

ETSI TS 125 453 V7.1.0 (2005-12)

Technical Specification

**Universal Mobile Telecommunications System (UMTS);
UTRAN Iu-PS interface Positioning Calculation
Application Part (PCAP) signalling
(3GPP TS 25.453 version 7.1.0 Release 7)**



Reference

RTS/TSGR-0325453v710

Keywords

UMTS

ETSI

650 Route des Lucioles
F-06921 Sophia Antipolis Cedex - FRANCE

Tel.: +33 4 92 94 42 00 Fax: +33 4 93 65 47 16

Siret N° 348 623 562 00017 - NAF 742 C
Association à but non lucratif enregistrée à la
Sous-Préfecture de Grasse (06) N° 7803/88

Important notice

Individual copies of the present document can be downloaded from:

<http://www.etsi.org>

The present document may be made available in more than one electronic version or in print. In any case of existing or perceived difference in contents between such versions, the reference version is the Portable Document Format (PDF). In case of dispute, the reference shall be the printing on ETSI printers of the PDF version kept on a specific network drive within ETSI Secretariat.

Users of the present document should be aware that the document may be subject to revision or change of status. Information on the current status of this and other ETSI documents is available at

<http://portal.etsi.org/tb/status/status.asp>

If you find errors in the present document, please send your comment to one of the following services:

http://portal.etsi.org/chaicor/ETSI_support.asp

Copyright Notification

No part may be reproduced except as authorized by written permission.
The copyright and the foregoing restriction extend to reproduction in all media.

© European Telecommunications Standards Institute 2005.
All rights reserved.

DECT™, PLUGTESTS™ and UMTS™ are Trade Marks of ETSI registered for the benefit of its Members.
TIPHON™ and the TIPHON logo are Trade Marks currently being registered by ETSI for the benefit of its Members.
3GPP™ is a Trade Mark of ETSI registered for the benefit of its Members and of the 3GPP Organizational Partners.

Intellectual Property Rights

IPRs essential or potentially essential to the present document may have been declared to ETSI. The information pertaining to these essential IPRs, if any, is publicly available for **ETSI members and non-members**, and can be found in ETSI SR 000 314: *"Intellectual Property Rights (IPRs); Essential, or potentially Essential, IPRs notified to ETSI in respect of ETSI standards"*, which is available from the ETSI Secretariat. Latest updates are available on the ETSI Web server (<http://webapp.etsi.org/IPR/home.asp>).

Pursuant to the ETSI IPR Policy, no investigation, including IPR searches, has been carried out by ETSI. No guarantee can be given as to the existence of other IPRs not referenced in ETSI SR 000 314 (or the updates on the ETSI Web server) which are, or may be, or may become, essential to the present document.

Foreword

This Technical Specification (TS) has been produced by ETSI 3rd Generation Partnership Project (3GPP).

The present document may refer to technical specifications or reports using their 3GPP identities, UMTS identities or GSM identities. These should be interpreted as being references to the corresponding ETSI deliverables.

The cross reference between GSM, UMTS, 3GPP and ETSI identities can be found under <http://webapp.etsi.org/key/queryform.asp>.

Contents

Intellectual Property Rights	2
Foreword.....	2
Foreword.....	7
1 Scope	8
2 References	8
3 Definitions and abbreviations.....	9
3.1 Definitions	9
3.2 Abbreviations	9
4 General	10
4.1 Procedure Specification Principles.....	10
4.2 Forwards and Backwards Compatibility	10
4.3 Specification Notations	11
5 PCAP Services	11
6 Services Expected from Signalling Transport.....	11
7 Functions of PCAP	12
8 PCAP Procedures	12
8.1 Elementary Procedures.....	12
8.2 Position Calculation	13
8.2.1 General.....	13
8.2.2 Successful Operation	13
8.2.3 Unsuccessful Operation	14
8.2.4 Abnormal Conditions.....	14
8.3 Information Exchange Initiation.....	15
8.3.1 General.....	15
8.3.2 Successful Operation	15
8.3.3 Unsuccessful Operation	17
8.3.4 Abnormal Conditions.....	17
8.4 Information Reporting.....	17
8.4.1 General.....	17
8.4.2 Successful Operation	18
8.4.3 Abnormal Conditions.....	18
8.5 Information Exchange Termination	18
8.5.1 General.....	18
8.5.2 Successful Operation	18
8.5.3 Abnormal Conditions.....	19
8.6 Information Exchange Failure.....	19
8.6.1 General.....	19
8.6.2 Successful Operation	19
8.7 Error Indication	19
8.7.1 General.....	19
8.7.2 Successful Operation	20
8.7.3 Abnormal Conditions.....	20
8.8 Position Initiation	20
8.8.1 General.....	20
8.8.2 Successful Operation	21
8.8.3 Unsuccessful Operation	21
8.8.4 Abnormal Conditions.....	22
8.9 Position Activation	22
8.9.1 General.....	22
8.9.2 Successful Operation	22
8.9.3 Unsuccessful Operation	23

8.9.4	Abnormal Conditions.....	23
8.10	Position Parameter Modification.....	23
8.10.1	General.....	23
8.10.2	Successful Operation	23
8.10.3	Abnormal Conditions.....	24
8.11	Abort	24
8.11.1	General.....	24
8.11.2	Successful Operation	24
8.11.3	Abnormal Conditions.....	25
9	Elements for PCAP Communication.....	25
9.1	Message Functional Definition and Content	25
9.1.1	General.....	25
9.1.2	Message Contents	25
9.1.2.1	Presence	25
9.1.2.2	Criticality	25
9.1.2.3	Range	25
9.1.2.4	Assigned Criticality.....	26
9.1.3	POSITION CALCULATION REQUEST	26
9.1.4	POSITION CALCULATION RESPONSE.....	27
9.1.5	POSITION CALCULATION FAILURE	27
9.1.6	INFORMATION EXCHANGE INITIATION REQUEST	27
9.1.7	INFORMATION EXCHANGE INITIATION RESPONSE.....	28
9.1.8	INFORMATION EXCHANGE INITIATION FAILURE	28
9.1.9	INFORMATION REPORT	28
9.1.10	INFORMATION EXCHANGE TERMINATION REQUEST	28
9.1.11	INFORMATION EXCHANGE FAILURE INDICATION	29
9.1.12	ERROR INDICATION.....	29
9.1.13	POSITION INITIATION REQUEST.....	29
9.1.14	POSITION INITIATION RESPONSE.....	29
9.1.15	POSITION INITIATION FAILURE.....	30
9.1.16	POSITION ACTIVATION REQUEST.....	30
9.1.17	POSITION ACTIVATION RESPONSE.....	31
9.1.18	POSITION ACTIVATION FAILURE.....	31
9.1.19	POSITION PARAMETER MODIFICATION	32
9.1.20	ABORT.....	32
9.2	Information Element Functional Definitions and Contents.....	32
9.2.1	General.....	32
9.2.2	Radio Network Layer Related IEs	32
9.2.2.1	Almanac and Satellite Health SIB.....	32
9.2.2.2	Altitude and direction.....	33
9.2.2.3	Cause.....	33
9.2.2.4	Criticality Diagnostics.....	36
9.2.2.5	DGPS Corrections.....	38
9.2.2.6	Geographical Area	39
9.2.2.7	Geographical Coordinates	41
9.2.2.8	GPS Acquisition Assistance.....	41
9.2.2.9	GPS Almanac and Satellite Health.....	42
9.2.2.10	GPS Clock and Ephemeris Parameters	43
9.2.2.11	GPS Ionospheric Model	45
9.2.2.12	GPS Measured Results	46
9.2.2.13	GPS Navigation Model	47
9.2.2.14	GPS Real Time Integrity	48
9.2.2.15	GPS Reference Time.....	48
9.2.2.16	GPS Transmission TOW	49
9.2.2.17	GPS UTC Model.....	49
9.2.2.18	GPS-UTRAN Time Relationship Uncertainty	49
9.2.2.19	Information Exchange ID.....	49
9.2.2.20	Information Exchange Object Type	49
9.2.2.21	Information Report Characteristics	50
9.2.2.22	Information Type	51
9.2.2.23	Message Structure	52

9.2.2.24	Message Type	52
9.2.2.25	Method Type	53
9.2.2.26	Requested Data Value	53
9.2.2.27	Requested Data Value Information	53
9.2.2.28	Transaction ID	53
9.2.2.29	Transmission TOW Indicator	54
9.2.2.30	Uncertainty Ellipse	54
9.2.2.31	Cell-ID Measured Results Info List	54
9.2.2.32	OTDOA Measured Results Info List	55
9.2.2.33	OTDOA Neighbour Cell Info	57
9.2.2.34	OTDOA Reference Cell Info	58
9.2.2.35	UE Positioning Measurement Quality	59
9.2.2.36	UTRAN Access Point Position with Altitude	60
9.2.2.37	UTRAN Cell Identifier (UC-ID)	60
9.2.2.38	Horizontal Accuracy Code	60
9.2.2.39	Vertical Accuracy Code	60
9.2.2.40	Accuracy Fulfilment Indicator	61
9.2.2.41	Uplink DPCH information	61
9.2.2.42	Frequency information	61
9.2.2.43	PRACH parameters	62
9.2.2.44	Compressed Mode Assistance Data	62
9.2.2.45	C-RNTI	63
9.2.2.46	Primary Scrambling Code	63
9.2.2.47	PRACH information	63
9.2.2.48	TFS	64
9.2.2.49	CTFC	65
9.2.2.50	Request Type	65
9.2.2.51	UE Positioning Capability	66
9.2.2.52	Response Time	66
9.2.2.53	Positioning Priority	66
9.2.2.54	Client Type	67
9.2.2.55	Positioning Method	67
9.2.2.56	U-TDOA Bit Count	67
9.2.2.57	U-TDOA Time Interval	67
9.2.2.58	T _{UTRAN-GPS} Measurement Value Information	68
9.2.2.59	UE Positioning OTDOA Assistance Data	68
9.2.2.60	UL TrCH information	70
9.2.2.61	Semi-static Transport Format Information	70
9.2.2.62	Environment Characterisation	71
9.2.2.63	Chip Offset	71
9.2.2.64	Frame Offset	71
9.2.2.65	Position Data	72
9.2.2.66	Transmission Gap Pattern Sequence Information	74
9.2.2.67	Active Pattern Sequence Information	74
9.2.2.68	CFN	75
9.2.2.69	Positioning Response Time	75
9.2.2.70	Reference Cell Position	76
9.2.2.71	UE Positioning IPDL Parameters	76
9.2.2.72	Burst Mode Parameters	76
9.2.2.73	SFN-SFN Relative Time Difference 1	76
9.2.2.74	UTDOA Group	77
9.2.2.75	Maximum Set of E-DPDCHs	77
9.2.1.76	Puncture Limit	78
9.2.2.77	E-DCH Transport Format Combination Set Information (E-TFCS Information)	78
9.2.2.78	Reference E-TFCI Power Offset	78
9.2.2.79	E-TTI	79
9.2.2.80	E-DPCCH Power Offset	79
9.2.2.81	Cell Parameter ID	79
9.2.2.82	TFCI Coding	79
9.2.2.83	Repetition Length	80
9.2.2.84	Repetition Period	80
9.2.2.85	TDD DPCH Offset	80

9.2.2.86	UL Timeslot Information	80
9.2.2.87	Time Slot	81
9.2.2.88	Midamble Shift And Burst Type	81
9.2.2.89	TFCI Presence	82
9.2.2.90	TDD UL Code Information	82
9.2.2.91	TDD Channelisation Code	83
9.2.2.92	Special Burst Scheduling	83
9.2.2.93	Max PRACH Midamble Shift	83
9.2.2.94	PRACH Midamble	83
9.2.2.95	USCH Parameters	84
9.2.2.96	USCH Scheduling Offset	84
9.3	Message and Information Element Abstract Syntax (with ASN.1)	85
9.3.0	General	85
9.3.1	Usage of private message mechanism for non-standard use	85
9.3.2	Elementary Procedure Definitions	85
9.3.3	PDU Definitions	89
9.3.4	Information Element Definitions	97
9.3.5	Common Definitions	130
9.3.6	Constant Definitions	131
9.3.7	Container Definitions	132
9.4	Message Transfer Syntax	134
10	Handling of Unknown, Unforeseen and Erroneous Protocol Data	134
10.1	General	134
10.2	Transfer Syntax Error	135
10.3	Abstract Syntax Error	135
10.3.1	General	135
10.3.2	Criticality Information	136
10.3.3	Presence Information	136
10.3.4	Not comprehended IE/IE group	137
10.3.4.1	Procedure Code	137
10.3.4.1A	Type of Message	137
10.3.4.2	IEs other than the Procedure Code and Type of Message	137
10.3.5	Missing IE or IE group	138
10.3.6	IEs or IE groups received in wrong order or with too many occurrences or erroneously present	139
10.4	Logical Error	139
10.5	Exceptions	140
Annex A (informative): Guidelines for Usage of the Criticality Diagnostics IE		141
A.1	EXAMPLE MESSAGE Layout	141
A.2	Example on a Received EXAMPLE MESSAGE	141
A.3	Content of Criticality Diagnostics	143
A.3.1	Example 1	143
A.3.2	Example 2	144
A.3.3	Example 3	145
A.3.4	Example 4	146
A.3.5	Example 5	147
A.4	ASN.1 of EXAMPLE MESSAGE	148
Annex B (informative): Change history		150
History		151

Foreword

This Technical Specification has been produced by the 3rd Generation Partnership Project (3GPP).

The contents of the present document are subject to continuing work within the TSG and may change following formal TSG approval. Should the TSG modify the contents of the present document, it will be re-released by the TSG with an identifying change of release date and an increase in version number as follows:

Version x.y.z

where:

- x the first digit:
 - 1 presented to TSG for information;
 - 2 presented to TSG for approval;
 - 3 or greater indicates TSG approved document under change control.
- y the second digit is incremented for all changes of substance, i.e. technical enhancements, corrections, updates, etc.
- z the third digit is incremented when editorial only changes have been incorporated in the document.

1 Scope

The present document specifies the *Positioning Calculation Application Part (PCAP)* between the Radio Network Controller (RNC) and the Stand-Alone SMLC (SAS). It fulfills the RNC-SAS communication requirements specified in [6] and thus defines the Iupc interface and its associated signaling procedures.

2 References

The following documents contain provisions which, through reference in this text, constitute provisions of the present document.

- References are either specific (identified by date of publication, edition number, version number, etc.) or non-specific.
- For a specific reference, subsequent revisions do not apply.
- For a non-specific reference, the latest version applies. In the case of a reference to a 3GPP document (including a GSM document), a non-specific reference implicitly refers to the latest version of that document *in the same Release as the present document*.

- [1] 3GPP TS 25.450: "UTRAN Iupc interface general aspects and principles".
- [2] 3GPP TS 25.451: "UTRAN Iupc interface layer 1".
- [3] 3GPP TS 25.452: "UTRAN Iupc interface signalling transport".
- [4] 3GPP TS 25.331: "Radio Resource Control (RRC) Protocol Specification".
- [5] 3GPP TS 25.401: "UTRAN Overall Description".
- [6] 3GPP TS 25.305: "Stage 2 functional specification of UE positioning in UTRAN".
- [7] ITU-T Recommendation X.680 (07/2002): "Information technology - Abstract Syntax Notation One (ASN.1): Specification of basic notation".
- [8] ITU-T Recommendation X.681 07/2002): "Information technology - Abstract Syntax Notation One (ASN.1): Information object specification".
- [9] ITU-T Recommendation X.691 (07/2002): "Information technology - ASN.1 encoding rules: Specification of Packed Encoding Rules (PER)".
- [10] ICD-GPS-200: (12 April 2000) "Navstar GPS Space Segment/Navigation User Interface".
- [11] 3GPP TS 23.032: "Universal Geographical Area Description (GAD)".
- [12] 3GPP TR 25.921: "Guidelines and principles for protocol description and error handling".
- [13] 3GPP TS 25.133: "Requirements for support of Radio Resource management (FDD)".
- [14] 3GPP TS 25.123: "Requirements for support of Radio Resource management (TDD)".
- [15] 3GPP TS 22.071: "Location Services (LCS); Service Description; Stage1".
- [16] 3GPP TS 25.212: "Multiplexing and Channel Coding (FDD)".
- [17] 3GPP TS 25.213: "Spreading and Modulation (FDD)".
- [18] 3GPP TS 25.223: "Spreading and Modulation (TDD)".
- [19] 3GPP TS 25.221: "Physical channels and mapping of transport channels onto physical channels (TDD)".
- [20] 3GPP TS 25.101: "User Equipment (UE) radio transmission and reception (FDD)".

[21] 3GPP TS 25.102: "UE radio transmission and reception (TDD)".

3 Definitions and abbreviations

3.1 Definitions

For the purposes of the present document, the following terms and definitions apply:

Stand-Alone SMLC (SAS): logical node that interconnects to the RNC over the Iupc interface via the PCAP protocol
An SAS performs the following procedures:

- provide GPS related data to the RNC;
- performs the position calculation function based upon UE Positioning measurement data.
- in SAS centric mode, selects the positioning method and controls the positioning procedure.

Elementary Procedure: PCAP consists of Elementary Procedures (EPs)

An Elementary Procedure is a unit of interaction between the RNC and the SAS. An EP consists of an initiating message and possibly a response message. Two kinds of EPs are used:

- **Class 1:** Elementary Procedures with response (success or failure).
- **Class 2:** Elementary Procedures without response.

For Class 1 EPs, the types of responses can be as follows:

Successful:

- A signalling message explicitly indicates that the elementary procedure successfully completed with the receipt of the response.

Unsuccessful:

- A signalling message explicitly indicates that the EP failed.

Class 2 EPs are considered always successful.

Information Exchange Context: Information Exchange Context is created by the first Information Exchange Initiation Procedure initiated by the RNC and requested from the SAS.

The Information Exchange Context is deleted after the Information Exchange Termination or the Information Exchange Failure procedure when there is no more Information Exchange to be provided by the RNC to the SAS. The Information Exchange Context is identified by an SCCP connection as, for Information Exchanges, only the connection oriented mode of the signalling bearer is used.

Positioning Initiation Context: In the SAS centric mode of operation each positioning request is assigned a unique logical connection identity, i.e., SCCP Source and Destination Local Reference numbers.

RNC Centric Mode of Operation: The RNC determines, initiates and controls the positioning method to be used for each positioning request.

SAS Centric Mode of Operation: The SAS determines, initiates and controls the positioning method to be used for each positioning request.

Positioning Event: The activity associated with the positioning of a UE resulting from the reception of UE positioning request from the CN.

3.2 Abbreviations

For the purposes of the present document, the following abbreviations apply:

A-GPS Assisted GPS

ASN.1	Abstract Syntax Notation One
CN	Core Network
CRNC	Controlling RNC
DGPS	Differential GPS
EP	Elementary Procedure
FDD	Frequency Division Duplex
GPS	Global Positioning System
MSC	Mobile services Switching Center
OTDOA	Observed Time Difference Of Arrival
PCAP	Positioning Calculation Application Part
PRC	Pseudorange Correction
RNC	Radio Network Controller
RNS	Radio Network Subsystem
RRC	Radio Resource Control
SAS	Stand-Alone SMLC
SCCP	Signalling Connection Control Part
SIB	System Information Block
SMLC	Serving Mobile Location Center
SRNC	Serving RNC
SRNS	Serving RNS
TDD	Time Division Duplex
TOW	Time of Week
UE	User Equipment
U-TDOA	Uplink Time Difference Of Arrival
UTRAN	Universal Terrestrial Radio Access Network

4 General

4.1 Procedure Specification Principles

The principle for specifying the procedure logic is to specify the functional behaviour of the SAS exactly and completely. The RNC functional behaviour is left unspecified.

The following specification principles have been applied for the procedure text in clause 8:

- The procedure text discriminates between:
 - 1) Functionality which "shall" be executed:
 - The procedure text indicates that the receiving node "shall" perform a certain function Y under a certain condition. If the receiving node supports procedure X but cannot perform functionality Y requested in the REQUEST message of a Class 1 EP, the receiving node shall respond with the message used to report unsuccessful outcome for this procedure, containing an appropriate cause value.
 - 2) Functionality which "shall, if supported" be executed:
 - The procedure text indicates that the receiving node "shall, if supported," perform a certain function Y under a certain condition. If the receiving node supports procedure X, but does not support functionality Y, the receiving node shall proceed with the execution of the EP, possibly informing the requesting node about the not supported functionality.
- Any required inclusion of an optional IE in a response message is explicitly indicated in the procedure text. If the procedure text does not explicitly indicate that an optional IE shall be included in a response message, the optional IE shall not be included.

4.2 Forwards and Backwards Compatibility

The forwards and backwards compatibility of the protocol is assured by mechanism where all current and future messages, and IEs or groups of related IEs, include Id and criticality fields that are coded in a standard format that will not be changed in the future. These parts can always be decoded regardless of the standard version.

4.3 Specification Notations

For the purposes of the present document, the following notations apply:

[FDD - ...]	This tagging indicates that the enclosed text following the "[FDD - " applies only to FDD. Multiple sequential paragraphs applying only to FDD are enclosed separately to enable insertion of TDD specific (or common) paragraphs between the FDD specific paragraphs.
[TDD - ...]	This tagging indicates that the enclosed text following the "[TDD - " applies only to TDD, including 3.84Mcps TDD and 1.28Mcps TDD. Multiple sequential paragraphs applying only to TDD are enclosed separately to enable insertion of FDD specific (or common) paragraphs between the TDD specific paragraphs.
Procedure	When referring to an elementary procedure in the specification the Procedure Name is written with the first letters in each word in upper case characters followed by the word "procedure", e.g. Position Calculation procedure.
Message	When referring to a message in the specification the MESSAGE NAME is written with all letters in upper case characters followed by the word "message", e.g. POSITION CALCULATION REQUEST message.
IE	When referring to an information element (IE) in the specification the <i>Information Element Name</i> is written with the first letters in each word in upper case characters and all letters in Italic font followed by the abbreviation "IE", e.g. <i>Request Type</i> IE.
Value of an IE	When referring to the value of an information element (IE) in the specification the "Value" is written as it is specified in clause 9.2 enclosed by quotation marks, e.g. "Abstract Syntax Error (Reject)" or "Geographical Coordinates ".

5 PCAP Services

PCAP provides the signalling services between RNC and SAS that are required to fulfill the PCAP functions described in clause 7. PCAP services are categorized as follows:

1. Position Calculation Service: They are related to a single UE and involve the transfer of UE Positioning measurement data and UE position estimate data over the Iupc interface between the SRNC and the SAS. They utilise connectionless signalling transport provided by the Iupc signalling bearer.
2. Information Exchange Service: They involve the transfer of GPS related data over the Iupc interface between the RNC and the SAS on demand, on modification, or at regular intervals. They utilise connection-oriented signalling transport provided by the Iupc signalling bearer.
3. SAS Centric Position Service: They are related to the capability of the SAS to determine the positioning method used for individual positioning events. In this case the SRNC may allow A-GPS, OTDOA, Cell ID and U-TDOA positioning events for a single UE to be originated by the SAS via PCAP messages. They utilise connection-oriented signalling transport provided by the Iupc signalling bearer.

6 Services Expected from Signalling Transport

Signalling transport [3] shall provide the following service for the PCAP.

1. Connection oriented data transfer service. This service is supported by a signalling connection between the RNC and the SAS. It shall be possible to dynamically establish and release signalling connections based on the need. Each point-to-point operation shall have its own signalling connection. The signalling connection shall provide in sequence delivery of PCAP messages. PCAP shall be notified if the signalling connection breaks.
2. Connectionless data transfer service. PCAP shall be notified in case a PCAP message did not reach the intended peer PCAP entity.

7 Functions of PCAP

PCAP has the following functions:

- Position Calculation. This function enables the SRNC to interact with an SAS in the process of performing a position estimate of a UE.
- Information Exchange. This function enables the RNC to obtain GPS related data from an SAS.
- Reporting of General Error Situations. This function allows reporting of general error situations for which function specific error messages have not been defined.
- SAS Centric Position. This function enables the SRNC to interact with an SAS in the process of performing a position estimate of a UE.

The mapping between the above functions and PCAP elementary procedures is shown in the table 1.

Table 1: Mapping between functions and PCAP elementary procedures

Function	Elementary Procedure(s)
Position Calculation	a) Position Calculation b) Position Parameter Modification c) Abort
Information Exchange	a) Information Exchange Initiation b) Information Reporting c) Information Exchange Termination d) Information Exchange Failure
Reporting of General Error Situations	a) Error Indication
SAS Centric Position	a) Position Initiation b) Position Activation c) Position Parameter Modification d) Abort

8 PCAP Procedures

8.1 Elementary Procedures

In the following tables, all EPs are divided into class 1 and class 2 EPs (see clause 3.1 for explanation of the different classes).

Table 2: Class 1

Elementary Procedure	Initiating Message	Successful Outcome	Unsuccessful Outcome
		Response message	Response message
Position Calculation	POSITION CALCULATION REQUEST	POSITION CALCULATION RESPONSE	POSITION CALCULATION FAILURE
Information Exchange Initiation	IIINFORMATION EXCHANGE INITIATION REQUEST	INFORMATION EXCHANGE INITIATION RESPONSE	INFORMATION EXCHANGE INITIATION FAILURE
Position Initiation	POSITION INITIATION REQUEST	POSITION INITIATION RESPONSE	POSITION INITIATION FAILURE
Position Activation	POSITION ACTIVATION REQUEST	POSITION ACTIVATION RESPONSE	POSITION ACTIVATION FAILURE

Table 3: Class 2

Elementary Procedure	Message
Information Reporting	INFORMATION REPORT
Information Exchange Termination	INFORMATION EXCHANGE TERMINATION REQUEST
Information Exchange Failure	INFORMATION EXCHANGE FAILURE INDICATION
Error Indication	ERROR INDICATION
Position Parameter Modification	POSITION PARAMETER MODIFICATION
Abort	ABORT

8.2 Position Calculation

8.2.1 General

The purpose of the Position Calculation procedure is to enable an SRNC to query an SAS for a position estimate of a UE. The procedure uses connectionless signalling.

8.2.2 Successful Operation

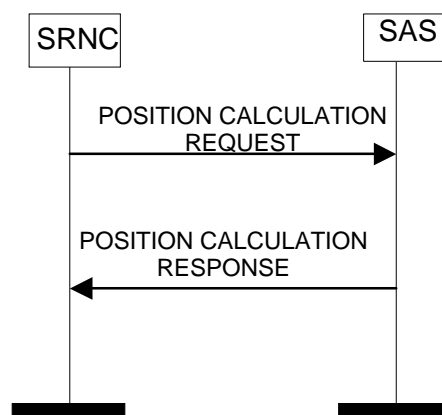

Figure 1: Position Calculation procedure, Successful Operation

The procedure is initiated with a POSITION CALCULATION REQUEST message sent from the SRNC to the SAS. When the SAS receives the POSITION CALCULATION REQUEST message, it shall calculate the UE position based on the provided measurement data.

If the *Initial UE Position Estimate* IE is included in the POSITION CALCULATION REQUEST message, the SAS shall use this value for the calculation of the UE Position Estimate in case of A-GPS positioning methods are used. The SAS may use this value for the calculation of the UE Position when any other methods are used.

If the *Horizontal Accuracy Code* IE and possibly the *Vertical Accuracy Code* IE are included in the POSITION CALCULATION REQUEST message, the SAS shall use these values in order to assess whether the resulting position estimation fulfills the requested accuracy.

If the *SAS Response Time* IE is included in the POSITION CALCULATION REQUEST message, the SAS shall send a POSITION CALCULATION RESPONSE message within the indicated time after reception of the POSITION CALCULATION REQUEST message.

Response Message:

If the SAS was able to calculate the position estimate, it shall respond with a POSITION CALCULATION RESPONSE message.

If at least the *Horizontal Accuracy Code* IE was included in the POSITION CALCULATION REQUEST message and the calculated position estimate fulfils the requested accuracy, the *Accuracy Fulfilment Indicator* IE with the value "requested accuracy fulfilled" shall be included in the POSITION CALCULATION RESPONSE message. If the calculated position estimate does not fulfil the requested accuracy, the *Accuracy Fulfilment Indicator* IE with the value "requested accuracy not fulfilled" shall be included in the POSITION CALCULATION RESPONSE message.

8.2.3 Unsuccessful Operation

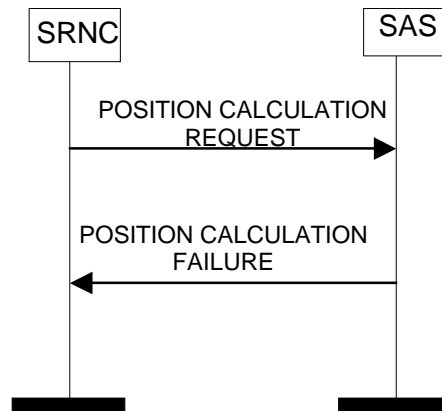

Figure 2: Position Calculation procedure, Unsuccessful Operation

If the SAS is unable to perform the position estimate for any reason, it shall return a POSITION CALCULATION FAILURE message to the SRNC.

Typical cause values are:

- Invalid reference information;
- Position calculation error: invalid GPS measured results;
- Initial UE Position Estimate missing;
- Processing Overload;
- Hardware Failure;
- O&M Intervention.;
- Invalid U-TDOA measured results;
- U-TDOA positioning method not supported;
- U-TDOA positioning method not supported in specified UTRAN cell;
- SAS unable to perform U-TDOA positioning within Response Time.

8.2.4 Abnormal Conditions

If the *Vertical Accuracy Code* IE is included and the *Horizontal Accuracy Code* IE is not included in the POSITION CALCULATION REQUEST message, the SAS shall reject the procedure.

If the RRC State is indicated as being *CELL_DCH* in the POSITION CALCULATION REQUEST message and [FDD - neither the *DCH Information* IE nor the *E-DPCH Information* IE][TDD – no *DCH Information* IE] is included, the SAS shall reject the procedure using the POSITION CALCULATION FAILURE message.

8.3 Information Exchange Initiation

8.3.1 General

This procedure is used by a RNC to request the initiation of an information exchange with a SAS.

This procedure uses the signalling bearer connection for the Information Exchange Context.

8.3.2 Successful Operation

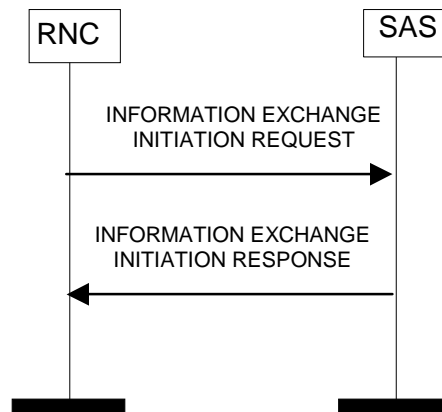

Figure 3: Information Exchange Initiation procedure, Successful Operation

The procedure is initiated with an INFORMATION EXCHANGE INITIATION REQUEST message sent from RNC to SAS.

If the *Information Type* IE is set to 'Implicit', the SAS is responsible for selecting the type of assistance data.

Upon reception, the SAS shall provide the requested information according to the parameters given in the request. Unless specified below, the meaning of the parameters are given in other specifications.

Information Report Characteristics:

The *Information Report Characteristics* IE indicates how the reporting of the information shall be performed.

If the *Information Report Characteristics* IE is set to 'On-Demand', the SAS shall report the requested information immediately.

If the *Information Report Characteristics* IE is set to "Periodic", the SAS shall report the requested information immediately and then shall periodically initiate the Information Reporting procedure for all the requested information, with the requested report frequency.

If the *Information Report Characteristics* IE is set to "On-Modification", the SAS shall report the requested information immediately if available. If the requested information is not available at the moment of receiving the INFORMATION EXCHANGE INITIATION REQUEST message, but expected to become available after some acquisition time, the SAS shall initiate the Information Reporting procedure when the requested information becomes available. The SAS shall then initiate the Information Reporting procedure in accordance to the following conditions:

- If the *Information Type* IE is set to "Explicit" and the *Explicit Information Item* IE includes "Almanac and Satellite Health", the SAS shall initiate the Information Reporting procedure for this specific Explicit Information Type when a change in the t_{oa} or WN_a parameter has occurred in almanac/health information for at least one visible satellite.
- If the *Information Type* IE is set to "Explicit" and the *Explicit Information Item* IE includes "UTC Model", the SAS shall initiate the Information Reporting procedure for this specific Explicit Information Type when a change in the t_{ot} or WN_t parameter has occurred in the GPS UTC model.
- If the *Transmission TOW Indicator* IE is set to "requested", then the SAS shall include the *GPS Transmission TOW* IE in the INFORMATION REPORT message.

- If the *Information Type* IE is set to 'Explicit' and the *Explicit Information Item* IE includes "Ionospheric Model", the SAS shall initiate the Information Reporting procedure for this specific Explicit Information Type when a change has occurred in the GPS ionospheric model.
- If the *Transmission TOW Indicator* IE is set to "requested", then the SAS shall include the *GPS Transmission TOW* IE in the INFORMATION REPORT message.
- If the *Information Type* IE is set to "Explicit" and the *Explicit Information Item* IE includes "Navigation Model", the SAS shall initiate the Information Reporting procedure for this specific Explicit Information Type when a change has occurred in the clock/ephemeris information for at least one visible satellite or in the list of visible satellites.
- If the *Transmission TOW Indicator* IE is set to "requested", then the SAS shall include the *GPS Transmission TOW* IE in the INFORMATION REPORT message.
- If the *Information Type* IE is set to "Explicit" and the *Explicit Information Item* IE includes "DGPS Corrections", the SAS shall initiate the Information Reporting procedure for this specific Explicit Information Type when a change has occurred in the quality of the DGPS corrections information for at least one visible satellite or in the list of visible satellites.
- If the *Information Type* IE is set to "Explicit" and the *Explicit Information Item* IE includes "Reference Time", the SAS shall initiate the Information Reporting procedure for this specific Explicit Information Type when a change has occurred in the time-of-week assistance information for at least one visible satellite or in the list of visible satellites.
- If the *Information Type* IE is set to "Explicit" and the *Explicit Information Item* IE includes "Acquisition Assistance", the SAS shall initiate the Information Reporting procedure for this specific Explicit Information Type when a change has occurred in acquisition assistance information for at least one visible satellite or in the list of visible satellites.
- If the *Information Type* IE is set to "Explicit" and the *Explicit Information Item* IE includes "Real Time Integrity", the SAS shall initiate the Information Reporting procedure for this specific Explicit Information Type when a change has occurred in the real-time integrity status of at least one visible satellite.
- If the *Information Type* IE is set to "Explicit" and the *Explicit Information Item* IE includes "Almanac and Satellite Health SIB", the SAS shall initiate the Information Reporting procedure for this specific Explicit Information Type when a change has occurred in almanac/health information for at least one visible satellite.
- If the *Transmission TOW Indicator* IE is set to "requested", then the SAS shall include the *GPS Transmission TOW* IE in the INFORMATION REPORT message.
- If any of the above *Information Type* IEs becomes temporarily unavailable, the SAS shall initiate the Information Reporting procedure for this specific Information Item by indicating "Information Not Available" in the *Requested Data Value Information* IE. If the Information becomes available again, the SAS shall initiate the Information Reporting procedure for this specific Information.

Response message:

If the SAS is able to determine the information requested by the RNC, it shall respond with the INFORMATION EXCHANGE INITIATION RESPONSE message. The message shall include the same Information Exchange ID that was included in the INFORMATION EXCHANGE INITIATION REQUEST message. When the *Report Characteristics* IE is set to "On Modification" or "Periodic", the INFORMATION EXCHANGE INITIATION RESPONSE message shall contain the *Requested Data Value* IE if the data are available. When the *Report Characteristics* IE is set to "On Demand", the INFORMATION EXCHANGE INITIATION RESPONSE message shall contain the *Requested Data Value* IE.

When the response message includes data to be reported (see above), the SAS shall include at least one IE in the *Requested Data Value* IE.

8.3.3 Unsuccessful Operation

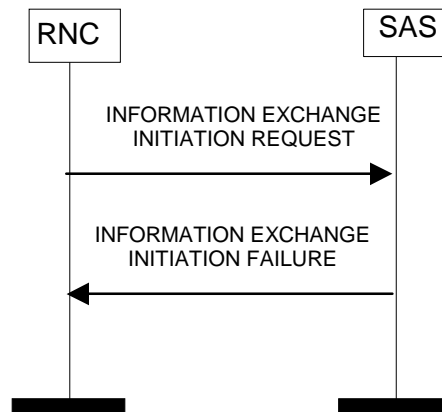

Figure 4: Information Exchange Initiation procedure, Unsuccessful Operation

If the requested Information Type received in the *Information Type* IE indicates a type of information that SAS cannot provide, the SAS shall regard the Information Exchange Initiation procedure as failed.

If the requested information provision cannot be carried out, the SAS shall send the INFORMATION EXCHANGE INITIATION FAILURE message. The message shall include the same Information Exchange ID that was used in the INFORMATION EXCHANGE INITIATION REQUEST message and the *Cause* IE set to an appropriate value.

Typical cause values are as follows:

- Information temporarily not available;
- Information Provision not supported for the object;
- Processing Overload;
- Hardware Failure;
- O&M Intervention.

8.3.4 Abnormal Conditions

-

8.4 Information Reporting

8.4.1 General

This procedure is used by a SAS to report the result of information requested by a RNC using the Information Exchange Initiation.

This procedure uses the signalling bearer connection for the Information Exchange Context.

8.4.2 Successful Operation

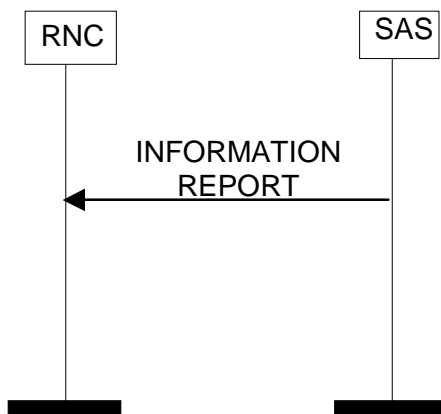

Figure 5: Information Reporting procedure, Successful Operation

If the requested information reporting criteria are met, the SAS shall initiate an Information Reporting procedure. Unless specified below, the meaning of the parameters are given in other specifications.

The *Information Exchange ID* IE shall be set to the Information Exchange ID provided by the RNC when initiating the information exchange with the Information Exchange Initiation procedure.

The *Requested Data Value* IE shall include at least one IE containing the data to be reported.

8.4.3 Abnormal Conditions

-

8.5 Information Exchange Termination

8.5.1 General

This procedure is used by a RNC to terminate the information exchange requested using the Information Exchange Initiation.

This procedure uses the signalling bearer connection for the Information Exchange Context.

8.5.2 Successful Operation

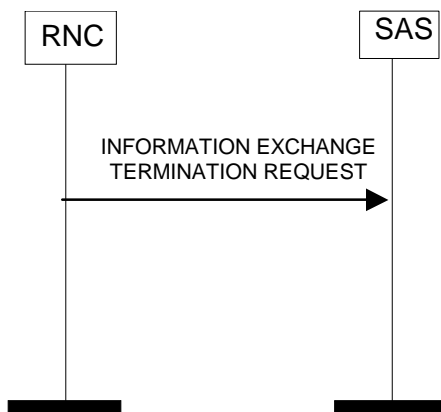

Figure 6: Information Exchange Termination procedure, Successful Operation

This procedure is initiated with an INFORMATION EXCHANGE TERMINATION REQUEST message.

Upon reception, the SAS shall terminate the information exchange corresponding to the Information Exchange ID.

8.5.3 Abnormal Conditions

-

8.6 Information Exchange Failure

8.6.1 General

This procedure is used by a SAS to notify a RNC that the information exchange it previously requested using the Information Exchange Initiation can no longer be reported.

This procedure uses the signalling bearer connection for the Information Exchange Context.

8.6.2 Successful Operation

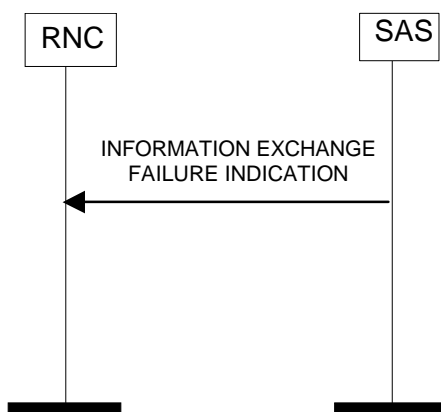

Figure 7: Information Exchange Failure procedure, Successful Operation

This procedure is initiated with a INFORMATION EXCHANGE FAILURE INDICATION message, sent from the SAS to the RNC, to inform the RNC that information previously requested by the Information Exchange Initiation procedure can no longer be reported. The message shall include the same Information Exchange ID that was used in the INFORMATION EXCHANGE INITIATION REQUEST message and the *Cause* IE set to an appropriate value.

Typical cause values are as follows:

- Information temporarily not available.

8.7 Error Indication

8.7.1 General

The Error Indication procedure is used by a node to report detected errors in one incoming message, provided they cannot be reported by an appropriate failure message.

8.7.2 Successful Operation

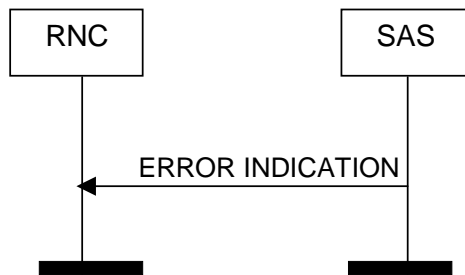

Figure 8: Error Indication procedure, SAS Originated, Successful Operation

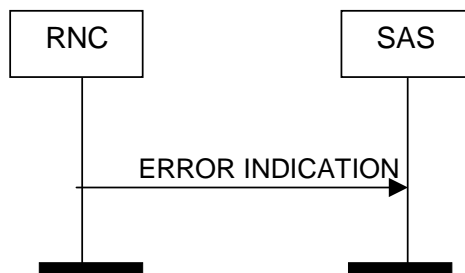

Figure 9: Error Indication procedure, RNC Originated, Successful Operation

When the conditions defined in clause 10 are fulfilled, the Error Indication procedure is initiated by an ERROR INDICATION message sent from the receiving node. This message shall use the same mode of the signalling bearer and the same signalling bearer connection (if connection oriented) as the message that triggers the procedure.

The ERROR INDICATION message shall include either the *Cause IE*, or the *Criticality Diagnostics IE*, or both the *Cause IE* and the *Criticality Diagnostics IE*.

Typical cause values are as follows:

- Transfer Syntax Error;
- Abstract Syntax Error (Reject);
- Abstract Syntax Error (Ignore and Notify);
- Message not Compatible with Receiver State;
- Unspecified.

8.7.3 Abnormal Conditions

-

8.8 Position Initiation

8.8.1 General

This procedure is used by an SRNC to request from an SAS the position of a UE using the SAS centric mode of operation.

The connection-oriented service of the signalling bearer shall be established in conjunction with this procedure.

8.8.2 Successful Operation

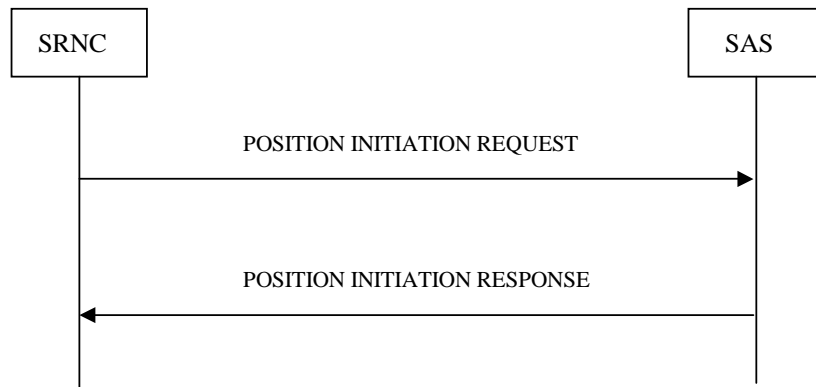

Figure 9a: Position Initiation procedure, Successful Operation

This procedure is initiated with a POSITION INITIATION REQUEST message sent from the SRNC to the SAS and ends with a POSITION INITIATION RESPONSE message from the SAS to the SRNC.

Response Message:

Following completion of one or more positioning attempts, possibly using multiple positioning methods, the SAS shall pass the UE position to the SRNC in a POSITION INITIATION RESPONSE message.

If at least the *Horizontal Accuracy Code* IE was included in the POSITION INITIATION REQUEST message and the calculated position estimate fulfils the requested accuracy, the *Accuracy Fulfilment Indicator* IE with the value "requested accuracy fulfilled" shall be included in the POSITION INITIATION RESPONSE message. If the calculated position estimate does not fulfil the requested accuracy, the *Accuracy Fulfilment Indicator* IE with the value "requested accuracy not fulfilled" shall be included in the POSITION INITIATION RESPONSE message.

8.8.3 Unsuccessful Operation

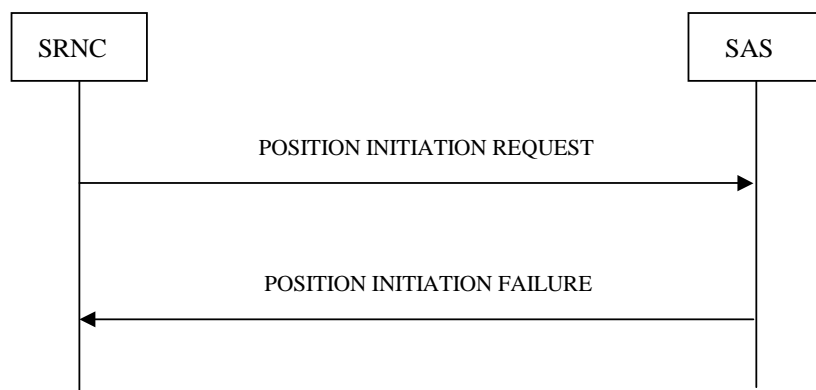

Figure 9b: Position Initiation procedure, Unsuccessful Operation

When the SAS is unable to accept a POSITION INITIATION REQUEST message or the SAS cannot provide a position estimate, the POSITION INITIATION FAILURE message shall be sent to the SRNC.

Typical cause values are:

- Processing Overload;
- Hardware Failure;

- O&M Intervention;
- Information temporarily not available

8.8.4 Abnormal Conditions

If the *Vertical Accuracy Code IE* is included and the *Horizontal Accuracy Code IE* is not included in the POSITION INITIATION REQUEST message, the SAS shall reject the procedure.

8.9 Position Activation

8.9.1 General

The purpose of the Position Activation procedure is to enable the SAS to initiate a particular positioning method used for an individual positioning event. This procedure uses connection-oriented signalling.

8.9.2 Successful Operation

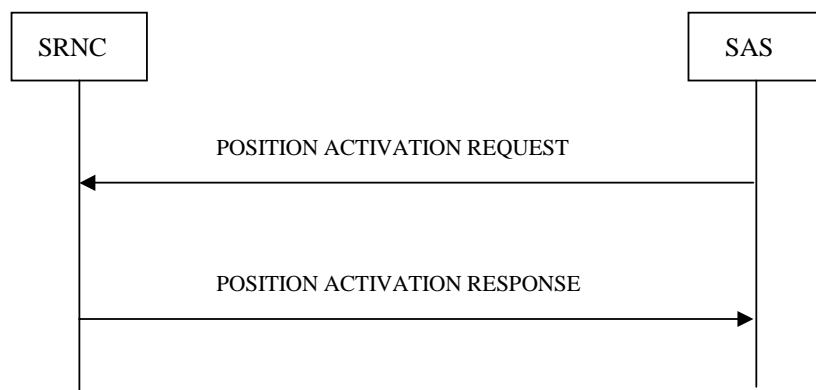

Figure 9c: Position Activation procedure, Successful Operation

The SAS initiates this procedure by sending a POSITION ACTIVATION REQUEST message to the SRNC containing the required positioning method and any assistance data and instructions associated with that positioning method. The SRNC then sends a POSITION ACTIVATION RESPONSE message to the SAS confirming the requested action and providing any information required by the requested positioning method; e.g. UE channel information for the U-TDOA positioning method or A-GPS measurements for UE assisted A-GPS. In the POSITION ACTIVATION RESPONSE message, the SRNC should include either the *GPS Measurement Results IE*, *Cell-ID Measured Results Sets IE*, *OTDOA Measured Results Sets IE* or *UTDOA Group IE*.

If the SRNC receives a new POSITION ACTIVATION REQUEST message before it has responded to a previous request, the SRNC should terminate all activity for the previous request, without sending any response to the initial request, and process the new request.

If the RRC State is indicated as being *CELL_DCH* in the POSITION ACTIVATION RESPONSE message, [FDD - either the *DCH Information IE* or the *E-DPCH Information IE*][TDD - the *DCH Information IE*] should be included.

8.9.3 Unsuccessful Operation

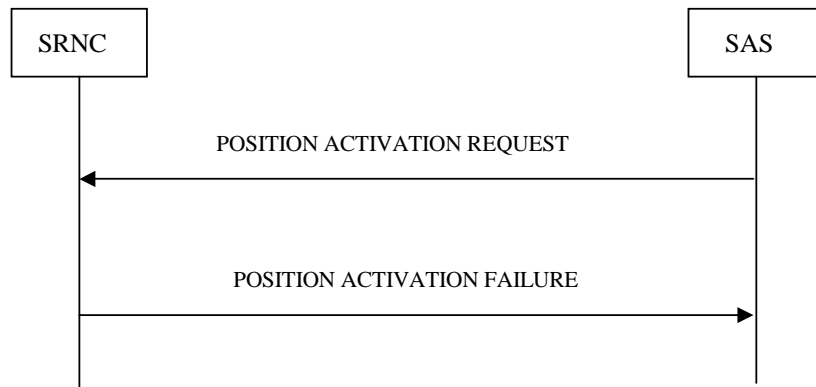

Figure 9d: Position Activation procedure, Unsuccessful Operation

When the SRNC is unable to accept a POSITION ACTIVATION REQUEST message, the POSITION ACTIVATION FAILURE message should be sent to the SAS.

Typical cause values are:

- Processing Overload;
- Hardware Failure;
- O&M Intervention;
- Positioning Method Not Supported
- Location Measurement Failure

8.9.4 Abnormal Conditions

-

8.10 Position Parameter Modification

8.10.1 General

The purpose of the Position Parameter Modification procedure is to inform the SAS of any relevant changes to the RF connection during a positioning event. This procedure uses connectionless signalling when invoked in RNC centric mode and connection-oriented signalling when invoked in SAS centric mode.

8.10.2 Successful Operation

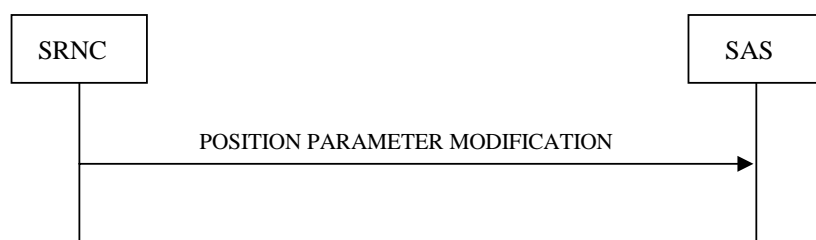

Figure 9e: Position Parameter Modification procedure, Successful Operation

If the SAS receives a POSITION PARAMETER MODIFICATION message, the SAS shall apply the information to the ongoing position estimate (e.g. reconfigure LMUs for U-TDOA) or to a new positioning attempt (e.g. use new serving cell to provide A-GPS assistance data). If there is more than one signalling connection for a UE, the SRNC should send the POSITION PARAMETER MODIFICATION message on each connection. When operating in the RNC centric mode the *Transaction ID* IE should be used to associate the POSITION PARAMETER MODIFICATION message to the correct positioning event.

In the POSITION PARAMETER MODIFICATION message, only one of the *UTRAN Cell Identifier* IE or the *UTDOA GROUP* IE should be included.

8.10.3 Abnormal Conditions

-

8.11 Abort

8.11.1 General

The purpose of the Abort procedure is to inform the SAS that the RNC is unable to continue the current positioning activity for a particular UE. This procedure uses connectionless signalling when invoked in RNC centric mode and connection-oriented signalling when invoked in SAS centric mode.

8.11.2 Successful Operation

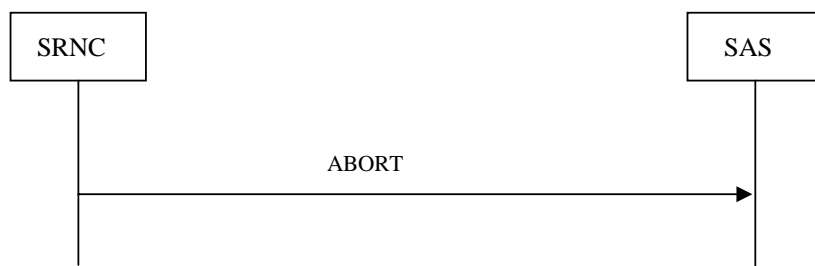

Figure 9f: Abort procedure, Successful Operation

The SRNC should send an ABORT message when the SRNC is unable to continue positioning activity due to cell reselection that results in a different SRNC, loss of contact with the UE or any other reason. When operating in the RNC centric mode the *Transaction ID* IE should be used to associate the ABORT message to the correct positioning event.

If the SAS receives an ABORT message while in the SAS centric mode it should immediately cease positioning attempts and return a POSITION INITIATION RESPONSE message to the SRNC carrying any location estimate already obtained or a POSITION INITIATION FAILURE message if no location estimate was obtained.

If the SAS receives an ABORT message while in the RNC centric mode it should immediately cease positioning attempts and return a POSITION CALCULATION RESPONSE message to the SRNC carrying any location estimate already obtained or a POSITION CALCULATION FAILURE message if no location estimate was obtained. After sending an ABORT message the SRNC should cease positioning activity, if any.

Typical cause values are:

- Processing Overload;
- Hardware Failure;
- O&M Intervention;
- Loss of contact with the UE

8.11.3 Abnormal Conditions

-

9 Elements for PCAP Communication

9.1 Message Functional Definition and Content

9.1.1 General

Clause 9.1 presents the contents of PCAP messages in tabular format. The corresponding ASN.1 definitions are presented in clause 9.3. In case there is contradiction between the tabular format in clause 9.1 and the ASN.1 definition, the ASN.1 shall take precedence, except for the definition of conditions for the presence of conditional IEs, where the tabular format shall take precedence.

NOTE: The messages have been defined in accordance to the guidelines specified in [12].

9.1.2 Message Contents

9.1.2.1 Presence

All information elements in the message descriptions below are marked mandatory, optional or conditional according to table 4.

Table 4: Meaning of abbreviations used in PCAP messages

Abbreviation	Meaning
M	IEs marked as Mandatory (M) shall always be included in the message.
O	IEs marked as Optional (O) may or may not be included in the message.
C	IEs marked as Conditional (C) shall be included in a message only if the condition is satisfied. Otherwise the IE shall not be included.

9.1.2.2 Criticality

Each Information Element or Group of Information Elements may have a criticality information applied to it. Following cases are possible.

Table 5: Meaning of content within "Criticality" column

Abbreviation	Meaning
-	No criticality information is applied explicitly.
YES	Criticality information is applied. This is usable only for non-repeatable IEs
GLOBAL	The IE and all its repetitions together have one common criticality information. This is usable only for repeatable IEs.
EACH	Each repetition of the IE has its own criticality information. It is not allowed to assign different criticality values to the repetitions. This is usable only for repeatable IEs.

9.1.2.3 Range

The Range column indicates the allowed number of copies of repetitive IEs/IE groups.

9.1.2.4 Assigned Criticality

This column provides the actual criticality information as defined in clause 10.3.2, if applicable.

9.1.3 POSITION CALCULATION REQUEST

Table 6

IE/Group Name	Presence	Range	IE type and reference	Semantics description	Criticality	Assigned Criticality
Message Type	M		9.2.2.24		YES	reject
Transaction ID	M		9.2.2.28		–	
Initial UE Position Estimate	O		Geographical Area 9.2.2.6		YES	reject
GPS Measured Results		<i>0..<maxNoOfSets ></i>			GLOBAL	reject
>GPS Measured Results	M		9.2.2.12		–	
Cell-ID Measured Results Sets		<i>0..<maxNoOfMeasurements></i>			GLOBAL	reject
>Cell-ID Measured Results Info List	M		9.2.2.31		–	
OTDOA Measurement Group		<i>0..1</i>			YES	reject
>OTDOA Reference Cell Info	M		9.2.2.34		–	
>OTDOA Neighbour Cell Info List		<i>1..<maxNoOfMeasurementsCell></i>			–	
>>OTDOA Neighbour Cell Info	M		9.2.2.33		–	
>OTDOA Measured Results Sets		<i>1..<maxNoOfMeasurements></i>			–	
>>OTDOA Measured Results Info List	M		9.2.2.32		–	
Horizontal Accuracy Code	O		9.2.2.38		YES	ignore
Vertical Accuracy Code	O		9.2.2.39		YES	ignore
UTDOA Group	O		9.2.2.74		YES	reject
SAS Response Time	O		Positioning Response Time 9.2.2.69	Indicates the interval allowed for a SAS response for U-TDOA positioning.	YES	ignore

Table 7

Range bound	Explanation
maxNoOfMeasNCell	Maximum number of neighbouring cells on which information can be reported. The value of maxNoOfMeasCell is 32.
maxNoOfSets	Maximum number of sets of Measured Results included in the Position Calculation Request message. The value for maxNoOfSets is 3.
maxNoOfMeasurements	Maximum number of Measurements of Cell-ID Measured Results Info List and OTDOA Measured Results Info List included in the Position Calculation Request message. The value for maxNoOfMeasurements is 16.

9.1.4 POSITION CALCULATION RESPONSE

Table 8

IE/Group Name	Presence	Range	IE type and reference	Semantics description	Criticality	Assigned Criticality
Message Type	M		9.2.2.24		YES	reject
Transaction ID	M		9.2.2.28		–	
UE Position Estimate	M		Geographical Area 9.2.2.6		YES	ignore
Criticality Diagnostics	O		9.2.2.4		YES	ignore
Accuracy Fulfilment Indicator	O		9.2.2.40		YES	ignore

9.1.5 POSITION CALCULATION FAILURE

Table 9

IE/Group Name	Presence	Range	IE type and reference	Semantics description	Criticality	Assigned Criticality
Message Type	M		9.2.2.24		YES	reject
Transaction ID	M		9.2.2.28		–	
Cause	M		9.2.2.3		YES	ignore
Criticality Diagnostics	O		9.2.2.4		YES	ignore

9.1.6 INFORMATION EXCHANGE INITIATION REQUEST

Table 10

IE/Group Name	Presence	Range	IE Type and Reference	Semantics Description	Criticality	Assigned Criticality
Message Type	M		9.2.2.24		YES	reject
Transaction ID	M		9.2.2.28		–	
Information Exchange ID	M		9.2.2.19		YES	reject
CHOICE <i>Information Exchange Object Type</i>	M				YES	reject
> <i>Reference Position</i>					–	
>> <i>Reference Position Estimate/UE Initial Position</i>	M		Geographical Area 9.2.2.6		–	
Information Type	M		9.2.2.22		YES	reject
Information Report Characteristics	M		9.2.2.21		YES	reject
GPS-UTRAN Time Relationship Uncertainty	C-GPS		9.2.2.18		YES	reject

Table 11

Condition	Explanation
GPS	The IE shall be present if the information requested in the <i>Information Type</i> IE contains GPS-related data

9.1.7 INFORMATION EXCHANGE INITIATION RESPONSE

Table 12

IE/Group Name	Presence	Range	IE Type and Reference	Semantics Description	Criticality	Assigned Criticality
Message Type	M		9.2.2.24		YES	reject
Transaction ID	M		9.2.2.28		–	
Information Exchange ID	M		9.2.2.19		YES	ignore
CHOICE <i>Information Exchange Object Type</i>	O				YES	ignore
> <i>Reference Position</i>					–	
>>Requested Data Value	M		9.2.2.26		–	
Criticality Diagnostics	O		9.2.2.4		YES	ignore

9.1.8 INFORMATION EXCHANGE INITIATION FAILURE

Table 13

IE/Group Name	Presence	Range	IE Type and Reference	Semantics Description	Criticality	Assigned Criticality
Message Type	M		9.2.2.24		YES	reject
Transaction ID	M		9.2.2.28		–	
Information Exchange ID	M		9.2.2.19		YES	ignore
Cause	M		9.2.2.3		YES	ignore
Criticality Diagnostics	O		9.2.2.4		YES	ignore

9.1.9 INFORMATION REPORT

Table 14

IE/Group Name	Presence	Range	IE Type and Reference	Semantics Description	Criticality	Assigned Criticality
Message Type	M		9.2.2.24		YES	ignore
Transaction ID	M		9.2.2.28		–	
Information Exchange ID	M		9.2.2.19		YES	ignore
CHOICE <i>Information Exchange Object Type</i>	M				YES	ignore
> <i>Reference Position</i>					–	
>>Requested Data Value Information	M		9.2.2.27		–	

9.1.10 INFORMATION EXCHANGE TERMINATION REQUEST

Table 15

IE/Group Name	Presence	Range	IE Type and Reference	Semantics Description	Criticality	Assigned Criticality
Message Type	M		9.2.2.24		YES	ignore
Transaction ID	M		9.2.2.28		–	
Information Exchange ID	M		9.2.2.19		YES	ignore

9.1.11 INFORMATION EXCHANGE FAILURE INDICATION

Table 16

IE/Group Name	Presence	Range	IE Type and Reference	Semantics Description	Criticality	Assigned Criticality
Message Type	M		9.2.2.24		YES	ignore
Transaction ID	M		9.2.2.28		-	
Information Exchange ID	M		9.2.2.19		YES	ignore
Cause	M		9.2.2.3		YES	ignore

9.1.12 ERROR INDICATION

Table 17

IE/Group Name	Presence	Range	IE type and reference	Semantics description	Criticality	Assigned Criticality
Message Type	M		9.2.2.24		YES	ignore
Transaction ID	M		9.2.2.28		-	
Cause	O		9.2.2.3		YES	ignore
Criticality Diagnostics	O		9.2.2.4		YES	ignore

9.1.13 POSITION INITIATION REQUEST

Table 17a

IE/Group Name	Presence	Range	IE type and reference	Semantics description	Criticality	Assigned Criticality
Message Type	M		9.2.2.24		YES	reject
Transaction ID	M		9.2.2.28		-	
Request Type	M		9.2.2.50		YES	reject
UE Positioning Capability	M		9.2.2.51		YES	reject
UTRAN Cell Identifier	M		9.2.2.37		YES	reject
Vertical Accuracy Code	O		9.2.2.39		YES	ignore
Response Time	O		9.2.2.52		YES	ignore
Positioning Priority	O		9.2.2.53		YES	ignore
Client Type	O		9.2.2.54		YES	ignore

9.1.14 POSITION INITIATION RESPONSE

Table 17b

IE/Group Name	Presence	Range	IE type and reference	Semantics description	Criticality	Assigned Criticality
Message Type	M		9.2.2.24		YES	reject
Transaction ID	M		9.2.2.28		-	
UE Position Estimate	M		Geographical Area 9.2.2.6		YES	reject
Position Data	M		9.2.2.65		YES	ignore
Accuracy Fulfilment Indicator	O		9.2.2.40		YES	ignore

9.1.15 POSITION INITIATION FAILURE

Table 17c

IE/Group Name	Presence	Range	IE type and reference	Semantics description	Criticality	Assigned Criticality
Message Type	M		9.2.2.24		YES	reject
Transaction ID	M		9.2.2.28		-	
Cause	M		9.2.2.3		YES	ignore
Criticality Diagnostics	O		9.2.2.4		YES	ignore

9.1.16 POSITION ACTIVATION REQUEST

Table 17d

IE/Group Name	Presence	Range	IE type and reference	Semantics description	Criticality	Assigned Criticality
Message Type	M		9.2.2.24		YES	reject
Transaction ID	M		9.2.2.28		-	
Positioning Method	M		9.2.2.55		YES	reject
RNC Response Time	M		Positioning Response Time 9.2.2.69	Indicates the interval of allowed for a RNC response	YES	ignore
Positioning Priority	O		9.2.2.53		YES	ignore
Environment Characterisation	O		9.2.2.62		YES	ignore
U-TDOA Positioning		0..1		Only present if Positioning Method is U-TDOA	YES	reject
>U-TDOA Bit Count	M		9.2.2.56	Used if UE is in CELL_FACH mode	-	
>U-TDOA Time Interval	M		9.2.2.57	Used if UE is in CELL_FACH mode	-	
GPS Assistance Data		0..1		Only present if Positioning Method is A-GPS	YES	reject
>Requested Data Value	M		9.2.2.26		-	
>T _{UTRAN-GPS} Measurement Value Information	O		9.2.2.58		-	
OTDOA Assistance Data		0..1		Only present if Positioning Method is OTDOA	YES	reject
>UE Positioning OTDOA Assistance data	M		9.2.2.59		-	

9.1.17 POSITION ACTIVATION RESPONSE

Table 17e

IE/Group Name	Presence	Range	IE type and reference	Semantics description	Criticality	Assigned Criticality
Message Type	M		9.2.2.24		YES	reject
Transaction ID	M		9.2.2.28		-	
UE Position Estimate	O		Geographical Area 9.2.2.6	Position information for UE based positioning methods	YES	ignore
GPS Measured Results		<i>0..<maxNoOfSets></i>			GLOBAL	reject
>GPS Measured Results	M		9.2.2.12		-	
Cell-ID Measured Results Sets		<i>0..<maxNoOfMeasurements></i>			GLOBAL	reject
>Cell-ID Measured Results Info List	M		9.2.2.31		-	
OTDOA Measured Results Sets		<i>0..<maxNoOfMeasurements></i>			GLOBAL	reject
>OTDOA Measured Results Info List	M		9.2.2.32		-	
UTDOA Group	O		9.2.2.74		YES	reject

Table 17f

Range bound	Explanation
MaxNoOfSets	Maximum number of sets of Measured Results included in the Position Calculation Request message. The value for maxNoOfSets is 3.
maxNoOfMeasurements	Maximum number of Measurements of Cell-ID Measured Results Info List and OTDOA Measured Results Info List included in the Position Calculation Request message. The value for maxNoOfMeasurements is 16.

9.1.18 POSITION ACTIVATION FAILURE

Table 17g

IE/Group Name	Presence	Range	IE type and reference	Semantics description	Criticality	Assigned Criticality
Message Type	M		9.2.2.24		YES	reject
Transaction ID	M		9.2.2.28		-	
Cause	M		9.2.2.3		YES	ignore
Criticality Diagnostics	O		9.2.2.4		YES	ignore

9.1.19 POSITION PARAMETER MODIFICATION

Table 17h

IE/Group Name	Presence	Range	IE type and reference	Semantics description	Criticality	Assigned Criticality
Message Type	M		9.2.2.24		YES	reject
Transaction ID	M		9.2.2.28		-	
UTRAN Cell Identifier	O		9.2.2.37		YES	reject
UTDOA Group	O		9.2.2.74		YES	reject

9.1.20 ABORT

Table 17i

IE/Group Name	Presence	Range	IE type and reference	Semantics description	Criticality	Assigned Criticality
Message Type	M		9.2.2.24		YES	reject
Transaction ID	M		9.2.2.28		-	
Cause	M		9.2.2.3		YES	ignore

9.2 Information Element Functional Definitions and Contents

9.2.1 General

Clause 9.2 presents the PCAP IE definitions in tabular format. The corresponding ASN.1 definitions are presented in clause 9.3. In case there is contradiction between the tabular format in clause 9.2 and the ASN.1 definition, the ASN.1 shall take precedence, except for the definition of conditions for the presence of conditional elements, where the tabular format shall take precedence.

When specifying information elements which are to be represented by bitstrings, if not otherwise specifically stated in the semantics description of the concerned IE or elsewhere, the following principle applies with regards to the ordering of bits:

- The first bit (leftmost bit) contains the most significant bit (MSB);
- The last bit (rightmost bit) contains the least significant bit (LSB);
- When importing bitstrings from other specifications, the first bit of the bitstring contains the first bit of the concerned information;

9.2.2 Radio Network Layer Related IEs

9.2.2.1 Almanac and Satellite Health SIB

Table 18

IE/Group Name	Presence	Range	IE Type and Reference	Semantics Description
GPS Almanac and Satellite Health	M		9.2.2.9	
SatMask	M		BIT STRING(1..32)	indicates the satellites that contain the pages being broadcast in this data set
LSB TOW	M		BIT STRING (8)	

9.2.2.2 Altitude and direction

Table 19

IE/Group Name	Presence	Range	IE type and reference	Semantics description
Direction of Altitude	M		ENUMERATED (Height, Depth)	
Altitude	M		INTEGER (0..2 ¹⁵ -1)	The relation between the value (N) and the altitude (a) in meters it describes is $N \leq a < N+1$, except for $N=2^{15}-1$ for which the range is extended to include all greater values of (a).

9.2.2.3 Cause

The purpose of the cause information element is to indicate the reason for a particular event for the whole protocol.

Table 20

IE/Group Name	Presence	Range	IE Type and Reference	Semantics Description
<i>CHOICE Cause Group</i>				
<i>>Radio Network Layer</i>				
>>Radio Network Layer Cause	M		ENUMERATED (invalid reference information, information temporarily not available, information provision not supported for the object, position calculation error: invalid GPS measured results, ..., position calculation error: invalid Cell-ID measured results, position calculation error: invalid OTDOA measured results, position calculation error: A-GPS positioning method not supported, position calculation error: Cell-ID positioning method not supported, position calculation error: OTDOA positioning method not supported, Initial UE Position Estimate missing, position calculation error: invalid U-TDOA measured results, position calculation error: U-TDOA positioning method not supported, position calculation error: U-TDOA positioning method not supported in specified UTRAN cell, positioning method not supported, loss of contact with UE, SAS unable to perform U-TDOA positioning within Response Time, Location measurement failure)	
<i>>Transport Layer</i>				
>>Transport Layer Cause	M		ENUMERATED (Transport Resource Unavailable, Unspecified, ...)	
<i>>Protocol</i>				
>>Protocol Cause	M		ENUMERATED (Transfer Syntax Error, Abstract Syntax Error (Reject), Abstract Syntax Error (Ignore and Notify), Message not Compatible with Receiver State, Semantic Error, Unspecified, Abstract Syntax Error (Falsely Constructed Message), ...)	
<i>>Misc</i>				
>>Misc Cause	M		ENUMERATED (Processing Overload, Hardware Failure, O&M Intervention, Unspecified, ...)	

The meaning of the different cause values is described in the following table. In general, "not supported" cause values indicate that the concerning capability is missing. On the other hand, "not available" cause values indicate that the concerning capability is present, but insufficient resources were available to perform the requested action.

Table 21

Radio Network Layer cause	Meaning
Invalid reference information	The reference information (GPS-UTRAN Time Relationship Uncertainty and/or Initial UE Position Estimate) provided by the RNC are invalid
Information temporarily not available	The information requested by RNC is temporarily not available
Information Provision not supported for the object	The SAS does not support provision of the requested information for the concerned object types
Position calculation error: invalid GPS measured results	The SAS cannot calculate position due to invalid GPS measured results
Position calculation error: invalid Cell-ID measured results	The SAS cannot calculate position due to invalid Cell-ID measured results
Position calculation error: invalid OTDOA measured results	The SAS cannot calculate position due to invalid OTDOA measured results
Position calculation error: A-GPS positioning method not supported	The SAS cannot calculate position because it does not support the A-GPS positioning method
Position calculation error: Cell-ID positioning method not supported	The SAS cannot calculate position because it does not support the Cell-ID positioning method
Position calculation error: OTDOA positioning method not supported	The SAS cannot calculate position because it does not support the OTDOA positioning method
Position calculation error: invalid U-TDOA measured results	The SAS cannot calculate position due to invalid U-TDOA measured results
Position calculation error: U-TDOA positioning method not supported	The SAS cannot calculate position because it does not support the U-TDOA positioning method
Position calculation error: U-TDOA positioning method not supported in specified UTRAN cell	The SAS cannot calculate position because it does not support the U-TDOA positioning method in the specified UTRAN cell
Positioning method not supported	The RNC does not support the requested positioning method
Loss of contact with UE	The RNC reports that it has lost contact with the UE
SAS unable to perform U-TDOA positioning within Response Time	The SAS did not send a U-TDOA position estimate within the interval defined by the Response Time IE
Location measurement failure	The SRNC cannot deliver the requested positioning measurement due to measurement failure.

Table 22

Transport Network Layer cause	Meaning
Transport resource unavailable	The required transport resources are not available
Unspecified	Sent when none of the above cause values applies but still the cause is Transport Network Layer related

Table 23

Protocol cause	Meaning
Abstract Syntax Error (Reject)	The received message included an abstract syntax error and the concerning criticality indicated "reject" (see clause 10.3)
Abstract Syntax Error (Ignore and Notify)	The received message included an abstract syntax error and the concerning criticality indicated "ignore and notify" (see clause 10.3)
Abstract syntax error (falsely constructed message)	The received message contained IEs or IE groups in wrong order or with too many occurrences (see clause 10.3)
Message not Compatible with Receiver State	The received message was not compatible with the receiver state (see clause 10.4)
Semantic Error	The received message included a semantic error (see clause 10.4)
Transfer Syntax Error	The received message included a transfer syntax error (see clause 10.2)
Unspecified	Sent when none of the above cause values applies but still the cause is Protocol related

Table 24

Miscellaneous cause	Meaning
Processing Overload	RNC/SAS processing overload
Hardware Failure	RNC/SAS hardware failure
O&M Intervention	Operation and Maintenance intervention related to RNC/SAS equipment
Unspecified	Sent when none of the above cause values applies and the cause is not related to any of the categories Radio Network Layer, Transport Network Layer or Protocol

9.2.2.4 Criticality Diagnostics

The *Criticality Diagnostics* IE is sent by the RNC or the SAS when parts of a received message have not been comprehended or are missing. It contains information about which IE was not comprehended or is missing.

For further details on how to use the *Criticality Diagnostics* IE, see annex A.

Table 25

IE/Group Name	Presence	Range	IE type and reference	Semantics description
Procedure Code	O		INTEGER (0..255)	
Triggering Message	O		ENUMERATED (initiating message, successful outcome, unsuccessful outcome, outcome)	The Triggering Message is used only if the Criticality Diagnostics is part of Error Indication.
Procedure Criticality	O		ENUMERATED (reject, ignore, notify)	This Procedure Criticality is used for reporting the Criticality of the Triggering message (Procedure).
Transaction ID	O		9.2.2.28	
Information Element Criticality Diagnostics		<i>0..<maxnoof errors></i>		
>IE Criticality	M		ENUMERATED (reject, ignore, notify)	The IE Criticality is used for reporting the criticality of the triggering IE. The value 'Ignore' shall never be used.
>IE Id	M		INTEGER (0..65535)	The IE Id of the not understood or missing IE as defined in the ASN.1 part of the specification.
>Repetition Number	O		INTEGER (0..255)	<p>The <i>Repetition Number</i> IE gives</p> <ul style="list-style-type: none"> - in case of a not understood IE: The number of occurrences of the reported IE up to and including the not understood occurrence - in case of a missing IE: The number of occurrences up to but not including the missing occurrence. <p>Note: All the counted occurrences of the reported IE must have the same top-down hierarchical message structure of IEs with assigned criticality above them.</p>
>Message Structure	O		9.2.2.23	The <i>Message Structure</i> IE describes the structure where the not understood or missing IE was detected. This IE is included if the not understood IE is not the top level of the message.
>Type of Error	M		ENUMERATED (not understood, missing, ...)	

Table 26

Range bound	Explanation
maxnooferrors	Maximum number of IE errors allowed to be reported with a single message. The value for maxnooferrors is 256.

9.2.2.5 DGPS Corrections

This IE contains DGPS corrections, which may be employed to compensate for ranging errors due to atmospheric delay, orbital modelling, and satellite clock drift.

Table 27

IE/Group Name	Presence	Range	IE Type and Reference	Semantics Description
GPS TOW sec	M		INTEGER (0..604799)	In seconds GPS time-of-week when the DGPS corrections were calculated
Status/Health	M		ENUMERATED (UDRE scale 1.0, UDRE scale 0.75, UDRE scale 0.5, UDRE scale 0.3, UDRE scale 0.2, UDRE scale 0.1, no data, invalid data)	
DPGS information	C-Status/Health	$1..<maxSat>$		
>SatID	M		INTEGER (0..63)	Identifies the satellite and is equal to (SV ID No - 1) where SV ID No is defined in [10].
>IODE	M		INTEGER (0..255)	
>UDRE	M		ENUMERATED (UDRE \leq 1.0 m, 1.0m < UDRE \leq 4.0m, 4.0m < UDRE \leq 8.0m, 8.0m < UDRE)	The value in this field shall be multiplied by the UDRE Scale Factor in the IE Status/Health to determine the final UDRE estimate for the particular satellite.
>PRC	M		INTEGER (-2047..2047.)	Scaling factor 0.32 Meters
>Range Rate Correction	M		INTEGER (-127..127)	Scaling factor 0.032 meters/sec

Table 28

Condition	Explanation
Status/Health	This IE shall be present if the <i>Status/Health</i> IE is not equal to "no data" or "invalid data"

Table 29

Range bound	Explanation
MaxSat	Maximum number of satellites for which data is included in this IE.

9.2.2.6 Geographical Area

Geographical Area IE is used to identify an area using geographical coordinates. The reference system is the same as the one used in [11].

Table 30

IE/Group Name	Presence	Range	IE type and reference	Semantics description
CHOICE <i>Geographical Area</i>				
> <i>Point</i>				Ellipsoid point
>>Geographical Coordinates	M		9.2.2.7	
> <i>Point With Uncertainty</i>				Ellipsoid point with uncertainty circle
>>Geographical Coordinates	M		9.2.2.7	
>>Uncertainty Code	M		INTEGER (0..127)	The uncertainty "r" expressed in meters is derived from the "Uncertainty Code" k by $r = 10x(1.1^{k-1})$
> <i>Polygon</i>				List of Ellipsoid points
>> Polygon		1..<maxnoofPoints>		
>>>Geographical Coordinates	M		9.2.2.7	
> <i>Ellipsoid point with uncertainty Ellipse</i>				
>>Geographical Coordinates	M		9.2.2.7	
>>Uncertainty Ellipse	M		9.2.2.30	
>>Confidence	M		INTEGER (0..100)	In percentage
> <i>Ellipsoid point with altitude</i>				
>>Geographical Coordinates	M		9.2.2.7	
>>Altitude and direction	M		9.2.2.2	
> <i>Ellipsoid point with altitude and uncertainty Ellipsoid</i>				
>>Geographical Coordinates	M		9.2.2.7	
>>Altitude and direction	M		9.2.2.2	
>>Uncertainty Ellipse	M		9.2.2.30	
>>Uncertainty Altitude	M		INTEGER (0..127)	The uncertainty altitude 'h' expressed in metres is derived from the 'Uncertainty Altitude' k, by: $h=45x(1.025^{k-1})$
>>Confidence	M		INTEGER (0..100)	In percentage
> <i>Ellipsoid Arc</i>				
>>Geographical Coordinates	M		9.2.2.7	
>>Inner radius	M		INTEGER (0..2 ¹⁶ -1)	The relation between the value (N) and the radius (r) in meters it describes is $5N \leq r < 5(N+1)$, except for $N=2^{16}-1$ for which the range is extended to include all greater values of (r).
>>Uncertainty radius	M		INTEGER (0..127)	The uncertainty "r" is derived from the "Uncertainty radius" k by $r = 10x(1.1^{k-1})$

IE/Group Name	Presence	Range	IE type and reference	Semantics description
>>Offset angle	M		INTEGER (0..179)	The relation between the value (N) and the angle (a) in degrees it describes is $2N \leq a < 2(N+1)$
>>Included angle	M		INTEGER (0..179)	The relation between the value (N) and the angle (a) in degrees it describes is $2N < a \leq 2(N+1)$
>>Confidence	M		INTEGER (0..100)	

Table 31

Range bound	Explanation
maxnoofPoints	Maximum no. of points in polygon. Value is 15.

9.2.2.7 Geographical Coordinates

This IE contains the geographical coordinates.

Table 32

IE/Group Name	Presence	Range	IE type and reference	Semantics description
Latitude Sign	M		ENUMERATED (North, South)	
Degrees Of Latitude	M		INTEGER (0.. $2^{23}-1$)	The IE value (N) is derived by this formula: $N \leq 2^{23} X / 90 < N+1$ X being the latitude in degree (0°.. 90°)
Degrees Of Longitude	M		INTEGER (-2^{23} .. $2^{23}-1$)	The IE value (N) is derived by this formula: $N \leq 2^{24} X / 360 < N+1$ X being the longitude in degree (-180°..+180°)

9.2.2.8 GPS Acquisition Assistance

This IE contains parameters that enable fast acquisition of the GPS signals in UE-assisted GPS positioning.

Table 33

IE/Group Name	Presence	Range	IE Type and Reference	Semantics Description
GPS TOW msec	M		INTEGER (0..6.048*10 ⁸ -1)	GPS Time of Week in milliseconds (rounded down to the nearest millisecond unit).
Satellite information		<i>1..<maxSat></i>		
>SatID	M		INTEGER (0..63)	Identifies the satellite and is equal to (SV ID No - 1) where SV ID No is defined in [10].
>Doppler (0 th order term)	M		INTEGER (-2048..2047)	Scaling factor 2.5Hz
>Extra Doppler		<i>0..1</i>		
>>Doppler (1 st order term)	M		INTEGER (-42..21)	Scaling factor 1/42
>>Doppler Uncertainty	M		ENUMERATED (12.5,25,50,100,200,...)	In Hz
>Code Phase	M		INTEGER (0..1022)	In Chips, specifies the centre of the search window
>Integer Code Phase	M		INTEGER (0..19)	Number of 1023 chip segments
>GPS Bit number	M		INTEGER (0..3)	Specifies GPS bit number (20 1023 chip segments)
>Code Phase Search Window	M		ENUMERATED (1023,1,2,3,4,6,8,12,16,24,32,48,64,96,128,192)	Specifies the width of the search window.
>Azimuth and Elevation		<i>0..1</i>		
>>Azimuth	M		INTEGER (0..31)	Scaling factor 11.25 Degrees
>>Elevation	M		INTEGER (0..7)	Scaling factor 11.25 Degrees

Table 34

Range bound	Explanation
mMaxSat	Maximum number of satellites for which data is included in this IE. The value of maxSat is 16.

9.2.2.9 GPS Almanac and Satellite Health

This IE contains a reduced-precision subset of the clock and ephemeris parameters.

Table 35

IE/Group Name	Presence	Range	IE Type and Reference	Semantics Description
WN _a	M		BIT STRING (8)	
Satellite information		<i>1..<maxSat Almanac></i>		
>DataID	M		BIT STRING (2)	See [10]
>SatID	M		INTEGER (0..63)	Identifies the satellite and is equal to (SV ID No - 1) where SV ID No is defined in [10].
>e	M		BIT STRING (16)	Eccentricity [10]
>t _{oa}	M		BIT STRING (8)	Reference Time of Almanac [10]
>δi	M		BIT STRING (16)	Correction to Inclination (semi-circles) [10]
>OMEGADOT	M		BIT STRING (16)	Rate of Right Ascension (semi-circles/sec) [10]
>SV Health	M		BIT STRING (8)	[10]
>A ^{1/2}	M		BIT STRING (24)	Semi-Major Axis (meters) ^{1/2} [10]
>OMEGA ₀	M		BIT STRING (24)	Longitude of Ascending Node of Orbit Plane at Weekly Epoch (semi-circles) [10]
>M ₀	M		BIT STRING (24)	Mean Anomaly at Reference Time (semi-circles) [10]
>ω	M		BIT STRING (24)	Argument of Perigee (semi-circles) [10]
>af ₀	M		BIT STRING (11)	apparent clock correction [10]
>af ₁	M		BIT STRING (11)	apparent clock correction [10]
SV Global Health	O		BIT STRING (364)	This enables GPS time recovery and possibly extended GPS correlation intervals

Table 36

Range bound	Explanation
maxSatAlmanac	Maximum number of satellites for which data is included in this IE. The value of maxSatAlmanac is 32.

9.2.2.10 GPS Clock and Ephemeris Parameters

The IE contains the GPS clock information and GPS Ephemeris.

Table 37

IE/Group Name	Presence	Range	IE Type and Reference	Semantics Description
C/A or P on L2	M		BIT STRING (2)	Code(s) on L2 Channel [10]
URA Index	M		BIT STRING (4)	User Range Accuracy [10]
SV Health	M		BIT STRING (6)	[10]
IODC	M		BIT STRING (10)	Issue of Data, Clock [10]
L2 P Data Flag	M		BIT STRING (1)	[10]
SF 1 Reserved	M		BIT STRING (87)	[10]
T _{GD}	M		BIT STRING (8)	Estimated group delay differential [10]
t _{oc}	M		BIT STRING (16)	apparent clock correction [10]
af ₂	M		BIT STRING (8)	apparent clock correction [10]
af ₁	M		BIT STRING (16)	apparent clock correction [10]
af ₀	M		BIT STRING (22)	apparent clock correction [10]
C _{rs}	M		BIT STRING (16)	Amplitude of the Sine Harmonic Correction Term to the Orbit Radius (meters) [10]
Δn	M		BIT STRING (16)	Mean Motion Difference From Computed Value (semi-circles/sec) [10]
M ₀	M		BIT STRING (32)	Mean Anomaly at Reference Time (semi-circles) [10]
C _{uc}	M		BIT STRING (16)	Amplitude of the Cosine Harmonic Correction Term To The Argument Of Latitude (radians) [10]
e	M		BIT STRING (32)	Eccentricity [10]
C _{us}	M		BIT STRING (16)	Amplitude of the Sine Harmonic Correction Term To The Argument Of Latitude (radians) [10]
(A) ^{1/2}	M		BIT STRING (32)	Semi-Major Axis (meters) ^{1/2} [10]
t _{oe}	M		BIT STRING (16)	Reference Time Ephemeris [10]
Fit Interval Flag	M		BIT STRING (1)	[10]
AODO	M		BIT STRING (5)	Age Of Data Offset [10]
C _{ic}	M		BIT STRING (16)	Amplitude of the Cosine Harmonic Correction Term To The Angle Of Inclination (radians) [10]
OMEGA ₀	M		BIT STRING (32)	Longitude of Ascending Node of Orbit Plane at Weekly Epoch (semi-circles) [10]
C _{is}	M		BIT STRING (16)	Amplitude of the Sine Harmonic Correction Term To The Angle Of Inclination (radians) [10]
i ₀	M		BIT STRING (32)	Inclination Angle at Reference Time (semi-circles) [10]
C _{rc}	M		BIT STRING (16)	Amplitude of the Cosine Harmonic Correction Term to the Orbit Radius (meters) [10]

ω	M		BIT STRING (32)	Argument of Perigee (semi-circles) [10]
OMEGAdot	M		BIT STRING (24)	Rate of Right Ascension (semi-circles/sec) [10]
ldot	M		BIT STRING (14)	Rate of Inclination Angle (semi-circles/sec) [10]

9.2.2.11 GPS Ionospheric Model

The IE contains fields needed to model the propagation delays of the GPS signals through the ionosphere.

Table 38

IE/Group Name	Presence	Range	IE Type and Reference	Semantics Description
α_0	M		BIT STRING (8)	NOTE 1
α_1	M		BIT STRING (8)	NOTE 1
α_2	M		BIT STRING (8)	NOTE 1
α_3	M		BIT STRING (8)	NOTE 1
β_0	M		BIT STRING (8)	NOTE 2
β_1	M		BIT STRING (8)	NOTE 2
β_2	M		BIT STRING (8)	NOTE 2
β_3	M		BIT STRING (8)	NOTE 2

NOTE 1: The parameters α_n are the coefficients of a cubic equation representing the amplitude of the vertical delay [10].

NOTE 2: The parameters β_n are the coefficients of a cubic equation representing the period of the ionospheric model [10].

9.2.2.12 GPS Measured Results

The purpose of this information element is to provide reported GPS measurement information from the SRNC to the SAS.

Table 39

IE/Group Name	Presence	Range	IE Type and Reference	Semantics Description
GPS TOW msec	M		INTEGER (0..6.048*10 ⁸ -1)	GPS Time of Week in milliseconds (rounded down to the nearest millisecond unit).
Measurement Parameters		1..<maxSat >		
>Satellite ID	M		INTEGER (0..63)	Identifies the satellite and is equal to (SV ID No - 1) where SV ID No is defined in [10].
>C/N ₀	M		INTEGER (0..63)	The estimate of the carrier-to-noise ratio of the received signal from the particular satellite used in the measurement. It is given in units of dB-Hz (Typical levels will be in the range of 20 – 50 dB-Hz).
>Doppler	M		INTEGER (-32768..-32768)	Hz, scale factor 0.2.
>Whole GPS Chips	M		INTEGER (0..1022)	Unit in GPS chips
>Fractional GPS Chips	M		INTEGER (0..(2 ¹⁰ -1))	Scale factor 2 ⁻¹⁰
>Multipath Indicator	M		ENUMERATED (NM, low, medium, high)	See NOTE 1
>Pseudorange RMS Error	M		INTEGER (0..63)	See NOTE 2

NOTE 1: Table 41 gives the mapping of the multipath indicator field.

NOTE 2: Table 42 gives the bitmapping of the Pseudorange RMS Error field.

Table 40

Range bound	Explanation
maxSat	Maximum number of satellites for which data is included in this IE. The value of maxSat is 16.

Table 41

Value	Multipath Indication
NM	Not measured
Low	MP error < 5m
Medium	5m < MP error < 43m
High	MP error > 43m

Table 42

Value	Mantissa	Exponent	Floating-Point value, x_i	Pseudorange value, P
0	000	000	0.5	$P < 0.5$
1	001	000	0.5625	$0.5 \leq P < 0.5625$
i	X	Y	$0.5 * (1 + x/8) * 2^y$	$x_{i-1} \leq P < x_i$
62	110	111	112	$104 \leq P < 112$
63	111	111	--	$112 \leq P$

9.2.2.13 GPS Navigation Model

This IE contain information required to manage the transfer of precise navigation data to the GPS-capable UE.

Table 43

IE/Group Name	Presence	Range	IE Type and Reference	Semantics Description
Satellite information		$1..<maxSat>$		
>SatID	M		INTEGER (0..63)	Identifies the satellite and is equal to (SV ID No - 1) where SV ID No is defined in [10].
>Satellite Status	M		ENUMERATED (NS_NN, ES_SN, ES_NN, REVD)	See NOTE
>GPS Clock and Ephemeris parameters	<i>C-Satellite status</i>		9.2.2.10	

NOTE: The UE shall interpret enumerated symbols as follows.

Table 44

Value	Indication
NS_NN	New satellite, new Navigation Model
ES_SN	Existing satellite, same Navigation Model
ES_NN	Existing satellite, new Navigation Model
REVD	Reserved

Table 45

Condition	Explanation
<i>Satellite status</i>	The IE shall be present if the <i>Satellite Status</i> IE is not set to ES_SN

Table 46

Range bound	Explanation
maxSat	Maximum number of satellites for which data is included in this IE. The value of maxSat is 16.

9.2.2.14 GPS Real Time Integrity

Table 47

IE/Group Name	Presence	Range	IE Type and Reference	Semantics Description
CHOICE <i>Bad Satellites Presence</i>				
>Bad Satellites				
>>Satellite information		1..<maxNo Sat>		
>>>BadSatID	M		INTEGER (0..63)	Identifies the satellite and is equal to (SV ID No - 1) where SV ID No is defined in [10].
>No Bad Satellites			NULL	

Table 48

Range bound	Explanation
maxNoSat	Maximum number of satellites for which data is included in this IE. The value of maxNoSat is 16.

9.2.2.15 GPS Reference Time

Table 49

IE/Group Name	Presence	Range	IE Type and Reference	Semantics Description
GPS Week	M		INTEGER (0..1023)	
GPS TOW msec	M		INTEGER (0..6.048*10 ⁸ -1)	GPS Time of Week in milliseconds (rounded down to the nearest millisecond unit).
GPS TOW Assist		0.. <maxSat >		
>SatID	M		INTEGER (0..63)	Identifies the satellite and is equal to (SV ID No - 1) where SV ID No is defined in [10].
>TLM Message	M		BIT STRING (14)	
>Anti-Spoof	M		BOOLEAN	
>Alert	M		BOOLEAN	
>TLM Reserved	M		BIT STRING (2)	

Table 50

Range bound	Explanation
maxSat	Maximum number of satellites for which data is included in this IE. The value of maxSat is 16.

9.2.2.16 GPS Transmission TOW

Table 51

IE/Group Name	Presence	Range	IE Type and Reference	Semantics Description
GPS Transmission TOW			INTEGER (0..604799)	The GPS time-of-week in seconds

9.2.2.17 GPS UTC Model

The UTC Model field contains a set of parameters needed to relate GPS time to Universal Time Coordinate (UTC).

Table 52

IE/Group Name	Presence	Range	IE Type and Reference	Semantics Description
A_1	M		BIT STRING (24)	sec/sec [10]
A_0	M		BIT STRING (32)	seconds [10]
t_{ot}	M		BIT STRING (8)	seconds [10]
Δt_{LS}	M		BIT STRING (8)	seconds [10]
WN_t	M		BIT STRING (8)	weeks [10]
WN_{LSF}	M		BIT STRING (8)	weeks [10]
DN	M		BIT STRING (8)	days [10]
Δt_{LSF}	M		BIT STRING (8)	seconds [10]

9.2.2.18 GPS-UTRAN Time Relationship Uncertainty

This IE contains the uncertainty of the GPS and UTRAN time relationship.

Table 53

IE/Group Name	Presence	Range	IE Type and Reference	Semantics Description
GPS-UTRAN Time Relationship Uncertainty			ENUMERATED (50ns, 500ns, 1us, 10us, 1ms, 10ms, 100ms, unreliable,...)	RNC estimate of uncertainty in GPS-UTRAN time relationship

9.2.2.19 Information Exchange ID

The Information Exchange ID uniquely identifies any requested information per RNC-SAS pair.

Table 54

IE/Group Name	Presence	Range	IE Type and Reference	Semantics Description
Information Exchange ID			INTEGER (0 .. 2^20-1)	

9.2.2.20 Information Exchange Object Type

Void.

9.2.2.21 Information Report Characteristics

The information report characteristics define how the reporting shall be performed.

Table 56

IE/Group Name	Presence	Range	IE Type and Reference	Semantics Description
Information Report Characteristics Type	M		ENUMERATED(On Demand, Periodic, On Modification, ...)	
CHOICE <i>Information Report Periodicity</i>	C-Periodic			Indicates the frequency with which the SAS shall send broadcast data reports.
>Min				
>>Minutes	M		INTEGER (1..60, ...)	
>Hour				
>>Hours	M		INTEGER (1..24, ...)	

Table 57

Condition	Explanation
Periodic	This IE shall be present if the <i>Information Report Characteristics Type</i> IE indicates 'periodic'

9.2.2.22 Information Type

The Information Type indicates which kind of information the SAS shall provide.

Table 58

IE/Group Name	Presence	Range	IE Type and Reference	Semantics Description
CHOICE <i>Information Type</i>				
>Implicit				
>>Method Type	M		9.2.2.25	
>Explicit				
>>Explicit Information		1..<maxnoofExplInfo>		
>>>CHOICE Explicit Information Item	M			
>>>>Almanac and Satellite Health			NULL	
>>>>UTC Model				
>>>>>Transmission TOW Indicator	M		9.2.2.29	
>>>>Ionospheric Model				
>>>>>Transmission TOW Indicator	M		9.2.2.29	
>>>>Navigation Model				
>>>>>Transmission TOW Indicator	M		9.2.2.29	
>>>>>Nav. Model Additional Data		0..1		
>>>>>>GPS Week	M		INTEGER (0..1023)	
>>>>>>GPS_Toe	M		INTEGER (0..167)	GPS time of ephemeris in hours of the latest ephemeris set
>>>>>>T-Toe limit	M		Integer (0..10)	ephemeris age tolerance in hours
>>>>>>Satellite related data		0..<maxSat>		
>>>>>>>SatID	M		INTEGER (0..63)	Identifies the satellite and is equal to (SV ID No - 1) where SV ID No is defined in [10].
>>>>>>>IODE	M		INTEGER (0..255)	Issue of Data Ephemeris for SatID
>>>>DGPS Corrections			NULL	
>>>>Reference Time			NULL	
>>>>Acquisition Assistance			NULL	
>>>>Real Time Integrity			NULL	
>>>>Almanac and Satellite Health SIB				
>>>>>Transmission TOW Indicator	M		9.2.2.29	

Table 59

Range Bound	Explanation
maxnoofExplInfo	Maximum number of Explicit Information supported in one Information Exchange. The value of maxnoofExplInfo is 32.
maxSat	Maximum number of satellites for which data is included in this IE. The value of maxSat is 16.

9.2.2.23 Message Structure

The *Message Structure* IE gives information for each level with assigned criticality in an hierarchical message structure from top level down to the lowest level above the reported level for the occurred error (reported in the *Information Element Criticality Diagnostics* IE).

Table 60

IE/Group Name	Presence	Range	IE type and reference	Semantics description
Message structure		<i>1..<maxnooflevels></i>		The first repetition of the <i>Message Structure</i> IE corresponds to the top level of the message. The last repetition of the <i>Message Structure</i> IE corresponds to the level above the reported level for the occurred error of the message.
>IE ID	M		INTEGER (0..65535)	The IE ID of this level's IE containing the not understood or missing IE.
>Repetition Number	O		INTEGER (1..256)	The <i>Repetition Number</i> IE gives, if applicable, the number of occurrences of this level's reported IE up to and including the occurrence containing the not understood or missing IE. Note: All the counted occurrences of the reported IE must have the same top-down hierarchical message structure of IEs with assigned criticality above them.

Table 61

Range bound	Explanation
maxnooflevels	Maximum no. of message levels to report. The value for maxnooflevels is 256.

9.2.2.24 Message Type

Message Type IE uniquely identifies the message being sent. It is mandatory for all messages.

Table 62

IE/Group Name	Presence	Range	IE Type and Reference	Semantics Description
Procedure Code	M		INTEGER(0..255)	'1' = Position Calculation '2' = Information Exchange Initiation '3' = Information Reporting '4' = Information Exchange Termination, '5' = Information Exchange Failure '6' = Error Indication '8' = Position Parameter Modification '9' = Position Initiation '10' = Position Activation '11' = Abort
Type of Message	M		ENUMERATED (Initiating Message, Successful Outcome, Unsuccessful Outcome, Outcome)	

9.2.2.25 Method Type

Table 63

IE/Group Name	Presence	Range	IE Type and Reference	Semantics Description
Method Type			ENUMERATED (UE_Assisted, UE_Based)	

9.2.2.26 Requested Data Value

The Requested Data Value contains the relevant data concerning the ongoing information exchange.

Table 64

IE/Group Name	Presence	Range	IE Type and Reference	Semantics Description
GPS Almanac and Satellite Health	O		9.2.2.9	
GPS UTC Model	O		9.2.2.17	
GPS Ionospheric Model	O		9.2.2.11	
GPS Navigation Model	O		9.2.2.13	
DGPS Corrections	O		9.2.2.5	
GPS Reference Time	O		9.2.2.15	
GPS Acquisition Assistance	O		9.2.2.8	
GPS Real Time Integrity	O		9.2.2.14	
Almanac and Satellite Health SIB	O		9.2.2.1	
GPS Transmission TOW	O		9.2.2.16	

9.2.2.27 Requested Data Value Information

The *Requested Data Value Information* IE provides information on whether or not the Requested Data Value is available in the message and also the Requested Data Value itself if available.

In case of "Periodic" and "On Modification" reporting, "Information Not Available" shall be used when at least one part of the requested information was not available at the moment of initiating the Information Reporting procedure.

Table 65

IE/Group Name	Presence	Range	IE Type and Reference	Semantics Description	Criticality	Assigned Criticality
CHOICE <i>Information Availability Indicator</i>	M				–	
> Information Available					–	
>>Requested Data Value	M		9.2.2.26		–	
> <i>Information not Available</i>			NULL		–	

9.2.2.28 Transaction ID

The Transaction ID is used to associate all the messages belonging to the same procedure. Messages belonging to the same procedure shall use the same Transaction ID.

The Transaction ID is determined by the initiating peer of a procedure.

The Transaction ID shall uniquely identify a procedure among all ongoing parallel procedures using the same procedure code, and initiated by the same protocol peer.

Table 66

IE/Group Name	Presence	Range	IE Type and Reference	Semantics Description
CHOICE <i>Transaction ID Length</i>				The Transaction ID shall be interpreted for its integer value, not for the type of encoding ("short" or "long").
> <i>Short</i>				
>>Transaction ID Value	M		INTEGER (0..127)	
> <i>Long</i>				
>>Transaction ID Value	M		INTEGER (0..32767)	

9.2.2.29 Transmission TOW Indicator

Table 67

IE/Group Name	Presence	Range	IE Type and Reference	Semantics Description
Transmission TOW Indicator			ENUMERATE D (requested, not requested)	

9.2.2.30 Uncertainty Ellipse

This IE contains the uncertainty ellipse of a geographical area.

Table 68

IE/Group Name	Presence	Range	IE type and reference	Semantics description
Uncertainty semi-major	M		INTEGER (0..127)	The uncertainty "r" is derived from the "uncertainty code" k by $r = 10 \times (1.1^k - 1)$
Uncertainty semi-minor	M		INTEGER (0..127)	The uncertainty "r" is derived from the "uncertainty code" k by $r = 10 \times (1.1^k - 1)$
Orientation of major axis	M		INTEGER (0..89)	The relation between the IE value (N) and the angle (a) in degrees it describes is $2N \leq a < 2(N+1)$

9.2.2.31 Cell-ID Measured Results Info List

This IE contains the Cell-ID measurements of signals associated with one or more cells.

Table 69

IE/Group Name	Presence	Range	IE Type and Reference	Semantics Description
Cell-ID Measured Results Info		$1..<maxNoOfMeasNCell>$		
>UC-ID	M		9.2.2.37	The identifier of the measured cell.
>UTRAN Access Point Position with Altitude	M		9.2.2.36	Exact geographical position of the base station antenna.
>Geographical Area	O		9.2.2.6	
>Round Trip Time Info		$0..1$		FDD only
>>UE Rx-Tx Time Difference Type 2	M		INTEGER (0..8191)	According to mapping in [13].
>>UE Positioning Measurement Quality	M		9.2.2.35	Quality of the UE Rx-Tx time difference measurement.
>>Round Trip Time	M		INTEGER (0..32766)	According to mapping in [13].
>Rx Timing Deviation Info		$0..1$		3.84Mcps TDD only
>>Rx Timing Deviation	M		INTEGER (0..8191)	According to mapping in [14].
>>Timing Advance	M		INTEGER (0..63)	According to [4].
>Rx Timing Deviation LCR Info		$0..1$		1.28Mcps TDD only
>>Rx Timing Deviation LCR	M		INTEGER (0..511)	According to mapping in [14].
>>Timing Advance LCR	M		INTEGER (0..2047)	According to mapping in [14].
>Pathloss	O		INTEGER (46..158)	Unit: dB downlink pathloss as defined in [4] subclause 10.3.7.3

Table 70

Range bound	Explanation
maxNoOfMeasNCell	Maximum number of neighbour cells on which information can be reported. The value of maxNoOfMeasNCell is 32.

9.2.2.32 OTDOA Measured Results Info List

This IE contains the OTDOA measurements of signals sent from the reference and neighbour cells.

Table 71

IE/Group Name	Presence	Range	IE Type and Reference	Semantics Description
OTDOA Measured Results Info		1..<MaxnoofMeasNCell>		
>UC-ID	M		9.2.2.37	The identifier of the neighbour cell.
>UE SFN-SFN Observed Time Difference Type 2 Info		1		
>>SFN-SFN Observed Time Difference Type 2	M		INTEGER (0..40961)	Gives the observed timing of the neighbour cell relative to the reference cell.
>>UE Positioning Measurement Quality	M		9.2.2.35	Quality of the observed time difference measurement.
>>Measurement Delay	M		INTEGER (0..65535)	The interval of time, in units of 10ms frames, spanning the following two events: 1) Time of applicability of the SFN-SFN Value or TUTORAN-GPS/SFN relationship provided for the corresponding neighbour cell in 9.2.2.33. 2) The point in time when this corresponding SFN-SFN observed time difference measurement was captured by the UE.

Table 72

Range bound	Explanation
MaxNoOfMeasNCell	Maximum number of neighbouring cells on which information can be reported. The value of MaxNoOfMeasNCell is 32.

9.2.2.33 OTDOA Neighbour Cell Info

Table 73

IE/Group Name	Presence	Range	IE Type and Reference	Semantics Description
UC-ID	M		9.2.2.37	The identifier of the neighbour cell.
UTRAN Access Point Position with Altitude	M		9.2.2.36	Exact geographical position of the base station antenna.
CHOICE <i>Relative Timing Difference Info</i>	M			
> <i>SFN-SFN Measurement Value Information</i>				
>>SFN-SFN Value	M		INTEGER (0..614399)	
>>SFN-SFN Quality	O		INTEGER (0..255)	Indicates the standard deviation (std) of the SFN-SFN otd (observed time difference) measurements in 1/16 chip. SFN-SFN Quality = $\sqrt{E[(x-\mu)^2]}$ = std of reported SFN-SFN Value, where x is the reported SFN-SFN Value and $\mu = E[x]$ is the expectation value of x.
>>SFN-SFN Drift Rate	M		INTEGER (-100..+100)	Indicates the SFN-SFN drift rate in 1/256 chip per second. A positive value indicates that the Reference cell clock is running at a greater frequency than the measured neighbouring cell.
>>SFN-SFN Drift Rate Quality	O		INTEGER (0..100)	Indicates the standard deviation (std) of the SFN-SFN drift rate measurements in 1/256 chip per second. SFN-SFN Drift Rate Quality = $\sqrt{E[(x-\mu)^2]}$ = std of reported SFN-SFN Drift Rate, where x is the reported SFN-SFN Drift Rate and $\mu = E[x]$ is the expectation value of x.
> <i>T_{UTRAN-GPS} Measurement Value Information</i>				
>>SFN	M		INTEGER (0..4095)	SFN during which the T _{UTRAN-GPS} measurement was performed
>>T _{UTRAN-GPS}		1		Indicates the UTRAN GPS Timing of Cell Frame for LCS.
>>>MS	M		INTEGER (0..16383)	Most significant part
>>>LS	M		INTEGER (0..4294967295)	Least significant part
>>T _{UTRAN-GPS} Quality	O		INTEGER (0..255)	Indicates the standard deviation (std) of the T _{UTRAN-GPS} measurements in 1/16 chip. T _{UTRAN-GPS} Quality = $\sqrt{E[(x-\mu)^2]}$ = std of reported T _{UTRAN-GPS} Value, where x is the reported T _{UTRAN-GPS} Value and $\mu = E[x]$ is the expectation value of x.
>>T _{UTRAN-GPS} Drift Rate	M		INTEGER (-50..+50)	Indicates the T _{UTRAN-GPS} drift rate in 1/256 chip per second. A positive value indicates that

				the UTRAN clock is running at a lower frequency than GPS clock.
>>T _{UTRAN-GPS} Drift Rate Quality	O		INTEGER (0..50)	Indicates the standard deviation (std) of the T _{UTRAN-GPS} drift rate measurements in 1/256 chip per second. T _{UTRAN-GPS} Drift Rate Quality = $\sqrt{E[(x-\mu)^2]}$ = std of reported T _{UTRAN-GPS} Drift Rate, where x is the reported T _{UTRAN-GPS} Drift Rate and $\mu = E[x]$ is the expectation value of x.

9.2.2.34 OTDOA Reference Cell Info

Table 74

IE/Group Name	Presence	Range	IE Type and Reference	Semantics Description
UC-ID	M		9.2.2.37	The identifier of the reference cell.
UTRAN Access Point Position with Altitude	M		9.2.2.36	Exact geographical position of the base station antenna.
T_{UTRAN-GPS} Measurement Value Information		0..1		
>SFN	M		INTEGER (0..4095)	SFN during which the T _{UTRAN-GPS} measurement was performed
>T _{UTRAN-GPS}		1		Indicates the UTRAN GPS Timing of Cell Frame for LCS.
>>MS	M		INTEGER (0..16383)	Most significant part
>>LS	M		INTEGER (0..4294967295)	Least significant part
>T _{UTRAN-GPS} Quality	O		INTEGER (0..255)	Indicates the standard deviation (std) of the T _{UTRAN-GPS} measurements in 1/16 chip. T _{UTRAN-GPS} Quality = $\sqrt{E[(x-\mu)^2]}$ = std of reported T _{UTRAN-GPS} Value, where x is the reported T _{UTRAN-GPS} Value and $\mu = E[x]$ is the expectation value of x.
>T _{UTRAN-GPS} Drift Rate	M		INTEGER (-50..+50)	Indicates the T _{UTRAN-GPS} drift rate in 1/256 chip per second. A positive value indicates that the UTRAN clock is running at a lower frequency than GPS clock.
>T _{UTRAN-GPS} Drift Rate Quality	O		INTEGER (0..50)	Indicates the standard deviation (std) of the T _{UTRAN-GPS} drift rate measurements in 1/256 chip per second. T _{UTRAN-GPS} Drift Rate Quality = $\sqrt{E[(x-\mu)^2]}$ = std of reported T _{UTRAN-GPS} Drift Rate, where x is the reported T _{UTRAN-GPS} Drift Rate and $\mu = E[x]$ is the expectation value of x.

9.2.2.35 UE Positioning Measurement Quality

Table 75

IE/Group Name	Presence	Range	IE Type and Reference	Semantics Description
Std Resolution	M		BIT STRING (2)	Std Resolution field includes the resolution used in Std of Measurements field. Encoding on two bits as follows: '00' 10 meters '01' 20 meters '10' 30 meters '11' Reserved
Number of Measurements	M		BIT STRING (3)	The 'Number of Measurements' field indicates how many measurements have been used in the UE to determine the sample standard deviation of the measurements. Following 3 bit encoding is used: '001' 5-9 '010' 10-14 '011' 15-24 '100' 25-34 '101' 35-44 '110' 45-54 '111' 55 or more Special case: '000': In this case the field 'Std of Measurements' contains the std of the reported measurement value = $\sqrt{E[(x-\mu)^2]}$, where x is the reported value and $\mu = E[x]$ is the expectation value (i.e. the true value) of x. This std can be used irrespective of the number of measurements and reporting of the number of measurements is not needed. Also other measurements such as Ec/No or Rx levels can be utilised in this case to evaluate the 'Std of Measurements' reported in this IE.
Std of Measurements	M		BIT STRING (5)	Std of Measurements field includes sample standard deviation of measurements (when number of measurements is reported in "Number of Measurements" field) or standard deviation of the reported measurement value = $\sqrt{E[(x-\mu)^2]}$, where x is the reported value and $\mu = E[x]$ is the expectation value (i.e. the true value) of x (when '000' is given in 'Number of Measurements' field). Following linear 5 bit encoding is used: '00000' 0 - (R*1-1) meters '00001' R*1 - (R*2-1) meters

				'00010' R*2 – (R*3-1) meters ... '11111' R*31 meters or more where R is the resolution defined by Std Resolution field. E.g. R=20 m corresponds to 0-19 m, 20-39 m,...,620+ m.
--	--	--	--	---

9.2.2.36 UTRAN Access Point Position with Altitude

The UTRAN Access Point Position with Altitude indicates the exact geographical position of the base station antenna. The altitude shall be included when available.

Table 76

IE/Group Name	Presence	Range	IE Type and Reference	Semantics Description
Geographical Coordinates	M		9.2.2.7	
Altitude and direction	O		9.2.2.2	

9.2.2.37 UTRAN Cell Identifier (UC-ID)

The UC-ID (UTRAN Cell identifier) is the identifier of a cell in one UTRAN.

Table 77

IE/Group Name	Presence	Range	IE Type and Reference	Semantics Description
RNC-ID	M		INTEGER (0..4095)	The identifier of one RNC in UTRAN.
C-ID	M		INTEGER (0..65535)	The identifier of a cell in one RNS.

9.2.2.38 Horizontal Accuracy Code

Table 78

IE/Group Name	Presence	Range	IE Type and Reference	Semantics Description
Horizontal Accuracy Code	M		INTEGER(0..127)	The requested accuracy "r" is derived from the "Horizontal Accuracy Code" k by $r = 10x(1.1^k - 1)$

9.2.2.39 Vertical Accuracy Code

Table 79

IE/Group Name	Presence	Range	IE Type and Reference	Semantics Description
Vertical Accuracy Code	M		INTEGER(0..127)	The requested accuracy "v" is derived from the "Vertical Accuracy Code" k by $v = 45x(1.025^k - 1)$.

9.2.2.40 Accuracy Fulfilment Indicator

This IE indicates whether the returned position estimate satisfies the requested accuracy or not.

Table 80

IE/Group Name	Presence	Range	IE Type and Reference	Semantics Description
Accuracy Fulfilment Indicator	M		ENUMERATED (requested accuracy fulfilled, requested accuracy not fulfilled, ...)	

9.2.2.41 Uplink DPCH information

This IE indicates the Uplink DPCH information used in the U-TDOA positioning method.

Table 81

IE/Group Name	Presence	Range	IE Type and Reference	Semantics Description
Choice <i>mode</i>	M			
> <i>FDD</i>				
>>Scrambling code type	M		ENUMERATED (short, long)	
>>Scrambling code number	M		INTEGER(0..16 777215)	
>>TFCI existence	M		BOOLEAN	TRUE means existence.
>>Number of FBI bits	M		INTEGER(0..2)	In bits.
> <i>TDD</i>				
>>Cell Parameter ID	M		9.2.2.81	
>>TFCI Coding	M		9.2.2.82	
>>Puncture Limit	M		9.2.2.76	
>>Repetition Period	M		9.2.2.84	
>>Repetition Length	M		9.2.2.83	
>>TDD DPCH Offset	M		9.2.2.85	
>>UL Timeslot Information	M		9.2.2.86	
>>Frame Offset	M		9.2.2.64	
>>Special Burst Scheduling	M		9.2.2.92	

9.2.2.42 Frequency information

This IE indicates the Frequency information used for the U-TDOA positioning method.

Table 82

IE/Group name	Presence	Range	IE Type and Reference	Semantics description
CHOICE <i>mode</i>	M			
> <i>FDD</i>				
>>UARFCN uplink (Nu)	O		INTEGER (0..16383)	If this IE is not present, the default duplex distance defined for the operating frequency band shall be used [20]
>>UARFCN downlink (Nd)	M		INTEGER (0 .. 16383)	[20]
> <i>TDD</i>				
>>UARFCN	M		INTEGER (0 .. 16383)	[21]

9.2.2.43 PRACH parameters

This IE indicates the PRACH parameter used for the U-TDOA positioning method.

Table 83

IE/Group name	Presence	Range	IE Type and Reference	Semantics description
PRACH parameters		1 .. $\langle \text{max}P \text{ RACH} \rangle$		
>PRACH information	M		9.2.2.47	
>TFS	M		9.2.2.48	
> TFC		1.. $\langle \text{max} \text{ TFC} \rangle$		
>>CTFC	M		9.2.2.49	

Table 84

Range bound	Explanation
maxPRACH	Maximum number of PRACHs in a cell. The value is 16.
maxTFC	Maximum number of TFC. Value is 1024.

9.2.2.44 Compressed Mode Assistance Data

This IE provides the assistance data used for the U-TDOA positioning method when the UE is operating in the compressed mode.

Table 85

IE/Group name	Presence	Range	IE Type and Reference	Semantics description
CHOICE <i>mode</i>	M			
> <i>FDD</i>				
>> Downlink information		1		
>>>Primary Scrambling Code	M		9.2.2.65	
>>>Chip Offset	M		9.2.2.63	
>>>Frame Offset	M		9.2.2.64	
>> Uplink information		1		

IE/Group name	Presence	Range	IE Type and Reference	Semantics description
>>>Transmission Gap Pattern Sequence Information	M		9.2.2.66	
>>>Active Pattern Sequence Information	M		9.2.2.67	
>>>CFN	M		9.2.2.68	

9.2.2.45 C-RNTI

The cell RNTI (C-RNTI) identifies a UE having a RRC connection within a cell that is used for the U-TDOA positioning method.

Table 86

IE/Group name	Presence	Range	IE Type and Reference	Semantics description
C-RNTI			BIT STRING(16)	

9.2.2.46 Primary Scrambling Code

This IE gives the DL scrambling code of a cell to which the UE is currently attached and is used for the U-TDOA positioning method.

Table 87

IE/Group name	Presence	Range	IE Type and Reference	Semantics description
Primary Scrambling Code			INTEGER(0..511)	

9.2.2.47 PRACH information

This IE contains the PRACH information used for the U-TDOA positioning method.

Table 88

IE/Group Name	Presence	Range	IE Type and Reference	Semantics Description
CHOICE mode	M			
>FDD				
>>Available Signature	M		BIT STRING (16)	Each bit indicates availability for a signature, where the signatures are numbered "signature 0" up to "signature 15". The value 1 of a bit indicates that the corresponding signature is available and the value 0 that it is not available.
>>Available SF	M		ENUMERATED (32,64,128,256, ...)	In chips per symbol Defines the minimum allowed SF (i.e. the maximum rate)
>>Preamble scrambling code number	M		INTEGER(0..15)	Identification of scrambling code see [17]
>>Puncturing Limit	M		9.2.2.76	
>>Available Sub Channel Number	M		BIT STRING (12)	Each bit indicates availability for a subchannel, where the subchannels are numbered "subchannel 0" to "subchannel 11". The value 1 of a bit indicates that the corresponding subchannel is available and the value 0 indicates that it is not available.
>TDD				
>>Time Slot	M		9.2.2.87	
>>TDD Channelisation Code	M		9.2.2.91	
>>Max PRACH Midamble Shifts	M		9.2.2.93	
>>PRACH Midamble	M		9.2.2.94	

9.2.2.48 TFS

This IE contains the TFS parameters used for the U-TDOA positioning method.

Table 89

IE/Group Name	Presence	Range	IE Type and Reference	Semantics Description
Dynamic Transport Format Information		1.. <maxT F>		
>RLC Size	M		INTEGER(129..5055)	Unit is bits
>Number of TBs and TTI List		1.. <maxT F>		Present for every valid number of TB's (and TTI) for this RLC Size.
>>Transmission time interval	C-dynamicTTI		ENUMERATED(10, 20, 40, 80, dynamic,...)	In ms. The value dynamic is only used in TDD mode.
>>Number of Transport blocks	M		INTEGER(0..512)	
Semi-static Transport Format Information	M		9.2.2.61	

Table 90

Range bound	Explanation
maxTF	Maximum number of Transport Formats. The value is 32.

Table 91

Condition	Explanation
dynamicTTI	This IE shall be present if TTI IE in Semi-static Transport Format Information IE is set to dynamic.

9.2.2.49 CTFC

This IE identifies the TFC used for the U-TDOA positioning method.

Table 92

IE/Group Name	Presence	Range	IE Type and Reference	Semantics Description
<i>CHOICE CTFC Size</i>				
<i>>2 bit CTFC</i>				
>>CTFC information	M		INTEGER(0..3)	
<i>>4 bit CTFC</i>				
>>CTFC information	M		INTEGER(0..15)	
<i>>6 bit CTFC</i>				
>>CTFC information	M		INTEGER(0..63)	
<i>>8 bit CTFC</i>				
>>CTFC information	M		INTEGER(0..255)	
<i>>12 bit CTFC</i>				
>>CTFC information	M		INTEGER(0..4095)	
<i>>16 bit CTFC</i>				
>>CTFC information	M		INTEGER(0..65535)	
<i>>24 bit CTFC</i>				
>>CTFC information	M		INTEGER(0..16777215)	

9.2.2.50 Request Type

This IE contains the Request Type parameters used for SAS centric positioning method selection.

Table 93

IE/Group Name	Presence	Range	IE Type and Reference	Semantics Description
Event	M		ENUMERATED(S top Change of service area, Direct, Change of service area, Stop Direct, ...)	Requests related to service area reporting are not supported in the current version of this specification.
Report Area	M		ENUMERATED(S ervice Area, Geographical Area, ...)	
Horizontal Accuracy Code	O		INTEGER(0..127)	The requested accuracy "r" is derived from the "accuracy code" k by $r = 10 \times (1.1^k - 1)$.

9.2.2.51 UE Positioning Capability

This IE contains the UE Positioning Capability information used for SAS centric positioning method selection.

Table 94

IE/Group Name	Presence	Range	IE Type and Reference	Semantics Description
Standalone location method(s) supported	M		BOOLEAN	Defines if a UE can measure its location by some means unrelated to UTRAN. TRUE means supported
UE based OTDOA supported	M		BOOLEAN	TRUE means supported
Network Assisted GPS support	M		ENUMERATED (Network based, UE based, Both, None,...)	Defines if the UE supports network based or UE based GPS methods.
Support for GPS timing of cell frames measurement	M		BOOLEAN	Defines if a UE has the capability to perform the UE GPS timing of cell frames measurement [4]. TRUE means capable
Support for IPDL	M		BOOLEAN	Defines if a UE has the capability to use IPDL to enhance its 'SFN-SFN observed time difference – type 2' measurement. TRUE means supported
Support for Rx-Tx time difference type2 measurement	M		BOOLEAN	TRUE means supported
Support for UE assisted GPS measurement validity in CELL_PCH and URA_PCH states	M		BOOLEAN	TRUE means supported
Support for SFN-SFN observed time difference type 2 measurement	M		BOOLEAN	TRUE means supported

9.2.2.52 Response Time

This IE contains the Response Time used for SAS centric mode.

Table 95

IE/Group Name	Presence	Range	IE Type and Reference	Semantics Description
Response Time			ENUMERATED(Low Delay, Delay Tolerant,...)	The value refers to [15].

9.2.2.53 Positioning Priority

This IE contains the Positioning Priority used for SAS centric mode.

Table 96

IE/Group Name	Presence	Range	IE Type and Reference	Semantics Description
Positioning Priority			ENUMERATED(High Priority, Normal Priority, ...)	The value refers to [15]

9.2.2.54 Client Type

This IE contains the Client Type used for SAS centric mode.

Table 97

IE/Group Name	Presence	Range	IE Type and Reference	Semantics Description
Client Type			ENUMERATED(Emergency Services, Value Added Services, PLMN Operator Services, Lawful Intercept Services, PLMN Operator - broadcast services, PLMN Operator - O&M, PLMN Operator - anonymous statistics, PLMN Operator - Target MS service support, ...)	Identifies the type of client.

9.2.2.55 Positioning Method

This IE contains the Positioning Method used for SAS centric positioning method selection.

Table 98

IE/Group Name	Presence	Range	IE Type and Reference	Semantics Description
Method Type	M		9.2.2.25	
Selected Position Method	M		ENUMERATED(OTDOA, GPS, OTDOA or GPS, Cell ID, UTDOA, ...)	

9.2.2.56 U-TDOA Bit Count

This IE contains the recommended number of pre-coded bits to be transmitted by the UE when the U-TDOA positioning method is selected.

Table 99

IE/Group Name	Presence	Range	IE Type and Reference	Semantics Description
U-TDOA Bit Count			INTEGER (0..5000)	Number of bits to be transmitted by the target UE

9.2.2.57 U-TDOA Time Interval

This IE contains the recommended maximum time interval for transmission of the U-TDOA Bit Count number of bits for U-TDOA positioning.

Table 100

IE/Group Name	Presence	Range	IE Type and Reference	Semantics Description
U-TDOA Time Interval			INTEGER (0..3000)	Time in ms in which the U-TDOA Bit Count is to be transmitted by the UE

9.2.2.58 $T_{\text{UTRAN-GPS}}$ Measurement Value Information

This IE contains the relationship between UTRAN time at a particular NodeB and GPS time.

Table 101

IE/Group Name	Presence	Range	IE Type and Reference	Semantics Description
Primary Scrambling Code	M		9.2.2.46	Identifies the cell in which $T_{\text{UTRAN-GPS}}$ was measured!
SFN	M		INTEGER(0..4095)	SFN during which the $T_{\text{UTRAN-GPS}}$ measurement was performed
$T_{\text{UTRAN-GPS}}$		1		Indicates the UTRAN GPS Timing of Cell Frame for UE Positioning according to mapping in [13].
>MS	M		INTEGER(0..16383)	Most significant part
>LS	M		INTEGER(0..4294967295)	Least significant part
$T_{\text{UTRAN-GPS}}$ Quality	O		INTEGER(0..255)	Indicates the standard deviation (std) of the $T_{\text{UTRAN-GPS}}$ measurements in 1/16 chip. $T_{\text{UTRAN-GPS}}$ Quality = $\sqrt{E[(x-\mu)^2]}$ = std of reported $T_{\text{UTRAN-GPS}}$ Value, where x is the reported $T_{\text{UTRAN-GPS}}$ Value and $\mu = E[x]$ is the expectation value of x.
$T_{\text{UTRAN-GPS}}$ Drift Rate	M		INTEGER(-50..+50)	Indicates the $T_{\text{UTRAN-GPS}}$ drift rate in 1/256 chip per second. A positive value indicates that the UTRAN clock is running at a lower frequency than GPS clock.
$T_{\text{UTRAN-GPS}}$ Drift Rate Quality	O		INTEGER (0..50)	Indicates the standard deviation (std) of the $T_{\text{UTRAN-GPS}}$ drift rate measurements in 1/256 chip per second. $T_{\text{UTRAN-GPS}}$ Drift Rate Quality = $\sqrt{E[(x-\mu)^2]}$ = std of reported $T_{\text{UTRAN-GPS}}$ Drift Rate, where x is the reported $T_{\text{UTRAN-GPS}}$ Drift Rate and $\mu = E[x]$ is the expectation value of x.

9.2.2.59 UE Positioning OTDOA Assistance Data

This IE contains the UE Positioning OTDOA Assistance Data used in the SAS centric mode.

Table 102

IE/Group Name	Presence	Range	IE Type and Reference	Semantics Description
UE Positioning OTDOA Reference Cell Info	O			
>SFN	O		INTEGER (0..4095)	Time stamp (SFN of Reference Cell) of the SFN-SFN relative time differences and SFN-SFN drift rates. Included if any SFN-SFN drift value is included in IE <i>UE positioning OTDOA neighbour cell info</i> .
>CHOICE mode				
>>Fdd				
>>>Primary CPICH Information	M		Primary scrambling code 9.2.2.46	
>>Tdd				
>Frequency Info	O		9.2.2.42	Default value is the existing value of frequency information. This IE shall always be set to default value
>CHOICE positioning mode				
>>UE Based				
>>> Cell position	O		Reference Cell Position 9.2.2.70	The position of the antenna that defines the cell.
>>> Round Trip Time	O		INTEGER (0..32766)	According to mapping in [13].
>>UE Assisted				
>UE positioning IPDL parameters	O		9.2.2.71	If this element is not included there are no idle periods present
UE Positioning OTDOA Neighbour Cell List	O			
>UE positioning OTDOA Neighbour cell info		1..maxCel lMeas		
>>CHOICE mode				
>>>FDD				
>>>>Primary CPICH Information	M		Primary scrambling code 9.2.2.46	
>>>TDD				
>>Frequency Info	O		9.2.2.42	Default value is the existing value of frequency information
>>UE positioning IPDL parameters	O		9.2.2.71	
>>SFN-SFN Relative Time difference1	M		9.2.2.73	
>>SFN Offset Validity	O		ENUMERATED (false)	Absence of this element means SFN offset is valid. False means SFN offset is not valid.
>>SFN-SFN Drift	O		ENUMERATED (0,1,2,3,4,5,8,10,15,25,35,50,65,80,100,-1,-2,-3,-4,-5,-8,-10,-15,-25,-35,-50,-65,-80,-100,...)	Indicates the SFN-SFN drift rate in 1/256 chip per second.
>>Search Window Size	M		ENUMERATED (c20, c40, c80, c160, c320, c640, c1280, moreThan1280,	In chips. If the value is X then the expected SFN-SFN observed time difference is in the range [RTD-X, RTD+X] where RTD is the value of the

			...)	field SFN-SFN relative time difference.
>>CHOICE positioning mode				
>>>UE Based				
>>>>Relative North	O		INTEGER (-20000..20000)	Seconds of angle, scale factor 0.03. Relative position compared to reference cell.
>>>> Relative East	O		INTEGER (-20000..20000)	Seconds of angle, scale factor 0.03. Relative position compared to reference cell.
>>>>Relative Altitude	O		INTEGER (-4000..4000)	Relative altitude in meters compared to ref. cell.
>>>>Fine SFNSFN	O		INTEGER (0..15)	Gives finer resolution
>>>>Round Trip Time	O		INTEGER (0..32766)	In chips. Included if cell is in active set
>>> UE assisted				

Table 103

Range bound	Explanation
maxCellMeas	Maximum number of cells to measure. The value is 32.

9.2.2.60 UL TrCH information

This IE contains the UL TrCH information used for the U-TDOA positioning method.

Table 104

IE/Group Name	Presence	Range	IE Type and Reference	Semantics Description
Uplink transport channel type	M		ENUMERATED (DCH,USCH,...)	USCH is TDD only
TFS	M		9.2.2.48	

9.2.2.61 Semi-static Transport Format Information

This IE contains the Semi-static Transport Format information used for the U-TDOA positioning method.

Table 105

IE/Group Name	Presence	Range	IE Type and Reference	Semantics description
Transmission time interval	M		ENUMERATED(5, 10, 20, 40, 80, dynamic, ...)	In ms. The value dynamic is only used in TDD mode
Type of channel coding	M		ENUMERATED(N o coding, Convolutional, Turbo, ...)	The option "No coding" is only valid for TDD.
Coding Rate	C-Coding		ENUMERATED(1/2, 1/3, ...)	
Rate matching attribute	M		INTEGER(1..hiRM)	
CRC size	M		ENUMERATED(0, 8, 12, 16, 24, ...)	In bits

Table 106

Condition	Explanation
Coding	This IE shall be present if Type of channel coding IE is 'Convolutional'.

Table 107

Constant	Explanation	Value
HiRM	Maximum number that could be set as rate matching attribute for a transport channel	256

9.2.2.62 Environment Characterisation

This IE contains the Environment Characterisation information used for the SAS centric mode.

Table 108

IE/Group Name	Presence	Range	IE Type and Reference	Semantics description
Environment Characterisation			ENUMERATED(heavy multipath and NLOS conditions, no or light multipath and usually LOS conditions, not defined or mixed environment, ...)	

9.2.2.63 Chip Offset

This IE contains the Chip Offset information used for the U-TDOA positioning method.

The Chip Offset is defined as the radio timing offset inside a radio frame. The Chip offset is used as offset relative to the Primary CPICH timing for the DL DPCH or for the F-DPCH.

Table 109

IE/Group Name	Presence	Range	IE Type and Reference	Semantics Description
Chip Offset			INTEGER(0..38399)	Unit: chips

9.2.2.64 Frame Offset

This IE contains the Frame Offset information used for the U-TDOA positioning method.

The Frame Offset is the required offset between the dedicated channel downlink transmission frames (CFN, Connection Frame Number) and the broadcast channel frame offset (Cell Frame Number). The Frame Offset is used in the translation between Connection Frame Number (CFN) on Iub/Iur and the least significant 8 bits of SFN (System Frame Number) on Uu. The Frame Offset is UE and cell specific

Table 110

IE/Group Name	Presence	Range	IE Type and Reference	Semantics Description
Frame Offset			INTEGER(0..255)	Unit: Frames

9.2.2.65 Position Data

This IE provides data related to the positioning methods used and reported in the SAS centric mode.

Table 111

IE/Group Name	Presence	Range	IE type and reference	Semantics description
Position Data				
>Positioning Data Discriminator	M		BIT STRING (4)	The positioning data discriminator defines the type of data provided for each positioning method: 0000 indicates usage of each positioning method that was successfully used to obtain the location estimate; 1 octet of data is provided for each positioning method included. All other values are reserved.
>Positioning Data Set	C- ifDiscrimina tor=0			

>>Positioning Method and Usage		1 ..<maxSet>	OCTET STRING (1)	Coding of positioning method (bits 8-4): 00000 Reserved 00001 Reserved 00010 Reserved 00011 Reserved 00100 Reserved 00101 Mobile Assisted GPS 00110 Mobile Based GPS 00111 Conventional GPS 01000 U-TDOA 01001 OTDOA 01010 IPDL 01011 RTT 01100 Cell ID 01101 to 01111 reserved for other location technologies 10000 to 11111 reserved for network specific positioning methods Coding of usage (bits 3-1): 000 Attempted unsuccessfully due to failure or interruption - not used. 001 Attempted successfully: results not used to generate location - not used. 010 Attempted successfully: results used to verify but not generate location - not used. 011 Attempted successfully: results used to generate location 100 Attempted successfully: case where MS supports multiple mobile based positioning methods and the actual method or methods used by the MS cannot be determined.
--------------------------------	--	--------------	------------------	---

Table 112

Condition	Explanation
ifDiscriminator=0	This IE is present if the <i>Positioning Data Discriminator</i> IE is set to "0000"

Table 113

Range bound	Explanation
maxSet	Maximum size of the data set. Value is 9.

9.2.2.66 Transmission Gap Pattern Sequence Information

This IE contains the Transmission Gap Pattern Sequence information used for the U-TDOA positioning method when the UE is operating in the compressed mode.

Table 114

IE/Group Name	Presence	Range	IE Type and Reference	Semantics Description
Transmission Gap Pattern Sequence Information		<i>1..<maxTGPS></i>		
>TGPS Identifier	M		INTEGER(1..maxTGPS)	Transmission Gap Pattern Sequence Identifier: Establish a reference to the compressed mode pattern sequence. Up to <maxTGPS> simultaneous compressed mode pattern sequences can be used.
>TGSN	M		INTEGER(0..14)	Transmission Gap Starting Slot Number: The slot number of the first transmission gap slot within the TGCFN.
>TGL1	M		INTEGER(1..14)	The length of the first Transmission Gap within the transmission gap pattern expressed in number of slots.
>TGL2	O		INTEGER(1..14)	The length of the second Transmission Gap within the transmission gap pattern. If omitted, then TGL2=TGL1.
>TGD	M		INTEGER(0,15..269)	Transmission Gap Distance: indicates the number of slots between the starting slots of two consecutive transmission gaps within a transmission gap pattern. If there is only one transmission gap in the transmission gap pattern, this parameter shall be set to "0" ("0" =undefined).
>TGPL1	M		INTEGER(1..14, ...)	The duration of transmission gap pattern 1 in frames.
>Uplink Compressed Mode Method	M		ENUMERATED(SF/2, Higher Layer Scheduling, ...)	Method for generating uplink compressed mode gap.

Table 115

Range bound	Explanation
maxTGPS	Maximum number of transmission gap pattern sequences. The value is 6.

9.2.2.67 Active Pattern Sequence Information

This IE contains the Active Pattern Sequence information used for the U-TDOA positioning method when the UE is operating in the compressed mode.

Table 116

IE/Group Name	Presence	Range	IE Type and Reference	Semantics Description
CM Configuration Change CFN	M		CFN 9.2.2.68	
Transmission Gap Pattern Sequence Status		<i>0..<maxTGPS></i>		
>TGPS Identifier	M		INTEGER(1..maxTGPS)	If the group is not present, none of the pattern sequences are activated. References an already defined sequence.
>TGPRC	M		INTEGER(0..511)	The number of transmission gap patterns within the Transmission Gap Pattern Sequence. "0"=Infinity
>TGCFN	M		CFN 9.2.2.68	Connection Frame Number of the first frame of the first pattern 1 within the Transmission Gap Pattern Sequence.

Table 117

Range bound	Explanation
maxTGPS	Maximum number of transmission gap pattern sequences. The value is 6.

9.2.2.68 CFN

This IE contains the CFN used for the U-TDOA positioning method when the UE is operating in the compressed mode.

Table 118

IE/Group Name	Presence	Range	IE Type and Reference	Semantics Description
CFN			INTEGER(0..255)	

9.2.2.69 Positioning Response Time

This IE contains the Positioning Response Time information used for SAS centric mode.

Table 119

IE/Group Name	Presence	Range	IE Type and Reference	Semantics Description
Positioning Response Time			ENUMERATED(250, 500, 1000, 2000, 3000, 4000, 6000, 8000, 12000, 16000, 20000, 24000, 28000, 32000, 64000, ...)	Unit: millisecond

9.2.2.70 Reference Cell Position

Reference Cell Position IE is used to identify the position of the reference cell using geographical coordinates. The reference system is the same as the one used in [11].

Table 120

IE/Group Name	Presence	Range	IE type and reference	Semantics description
<i>CHOICE Geographical Area</i>				
> <i>Point</i>				Ellipsoid point
>>Geographical Coordinates	M		9.2.2.7	
> <i>Ellipsoid point with altitude</i>				
>>Geographical Coordinates	M		9.2.2.7	
>>Altitude and direction	M		9.2.2.2	

9.2.2.71 UE Positioning IPDL Parameters

The *UE Positioning IPDL Parameters* IE is used for OTDOA in the SAS centric mode.

Table 121

IE/Group Name	Presence	Range	IE type and reference	Semantics description
<i>CHOICE mode</i>				
> <i>FDD</i>				
>>IP Spacing	M			
>>IP Length	M			
>>IP Offset	M		INTEGER(0..9)	
>>Seed	M		INTEGER(0..63)	
> <i>TDD</i>				
Burst Mode Parameters	O		9.2.2.72	

9.2.2.72 Burst Mode Parameters

Burst Mode Parameters IE is used for OTDOA in the SAS centric mode.

Table 122

IE/Group Name	Presence	Range	IE type and reference	Semantics description
Burst Start	M		INTEGER(0..15)	
Burst Length	M		INTEGER(10..25)	
Burst Frequency	M		INTEGER(1..16)	

9.2.2.73 SFN-SFN Relative Time Difference1

SFN-SFN Relative Time Difference IE is used for OTDOA in the SAS centric mode

Table 123

IE/Group Name	Presence	Range	IE type and reference	Semantics description
SFN Offset	M		INTEGER (0..4095)	
SFN-SFN-Relative Time Difference	M		INTEGER (0..38399)	

9.2.2.74 UTDOA Group

This IE contains information used for the U-TDOA positioning method.

Table 124

IE/Group Name	Presence	Range	IE Type and Reference	Semantics Description
UTRAN Cell Identifier	M		9.2.2.37	
Frequency Information	M		9.2.2.42	
Choice <i>RRC State</i>	M			
> <i>CELL_DCH</i>				
>>Uplink DPCH Information	M		9.2.2.41	
>>Compressed Mode Assistance Data	O		9.2.2.44	FDD only
>> DCH Information	0..1			
>>> TFCS	1..<maxTF C>			
>>>>CTFC	M		9.2.2.49	
>>> TrCH Information List	1..<maxTr CH>			
>>>>UL TrCH Information	M		9.2.2.60	
>> E-DPCH Information	0..1			FDD only
>>>Maximum Set of E-DPDCHs	M		9.2.2.75	
>>>Puncture Limit	M		9.2.2.76	
>>>E-TFCS Information	M		9.2.2.77	
>>>E-TTI	M		9.2.2.79	
>>>E-DPCCH Power Offset	O		9.2.2.80	
> <i>CELL_FACH</i>				
>>PRACH Parameters	M		9.2.2.43	
>>C-RNTI	M		9.2.2.45	
>>USCH parameters	O		9.2.2.95	TDD only

Table 125

Range bound	Explanation
maxTFC	Maximum number of TFC. The value is 1024.
maxTrCH	Maximum number of Transport Channels. The value is 32.

9.2.2.75 Maximum Set of E-DPDCHs

The Maximum Set of E-DPDCHs parameter, as defined in [16], is used in UTDOA positioning method.

Table 126

IE/Group Name	Presence	Range	IE Type and Reference	Semantics Description
Maximum Set of E-DPDCHs			ENUMERATED (vN64, vN32, vN16, vN8, vN4, v2xN4, v2xN2, v2xN2plus2xN4, ...)	

9.2.1.76 Puncture Limit

The Puncture Limit parameter is used in UTDOA positioning method indicating the limit in the amount of puncturing that can be applied in order to minimise the number of dedicated physical channels.

Table 127

IE/Group Name	Presence	Range	IE Type and Reference	Semantics Description
Puncture Limit			INTEGER (0..15)	Unit: % Range: 40..100 % Step: 4 % 100% means no puncturing

9.2.2.77 E-DCH Transport Format Combination Set Information (E-TFCS Information)

This IE is used in UTDOA positioning method. Whereas the related Transport Block sizes are standardised in [ref is FFS] this IE gives details on the referenced Transport Block Size Table and the Reference E-TFCIs.

Table 128

IE/Group Name	Presence	Range	IE Type and Reference	Semantics Description
E-DCH Transport Format Combination Set Index	M		INTEGER (1..4, ...)	Indicates which standardised E-TFCS Transport Block Size Table shall be used. The related tables are specified in [ref FFS].
Reference E-TFCI Information		<i>0..<maxnoofRefETFCIs></i>		
>Reference E-TFCI	M		INTEGER (0..127)	
>Reference E-TFCI Power Offset	M		9.2.2.78	

Table 129

Range Bound	Explanation
<i>maxnoofRefETFCIs</i>	Maximum number of signalled reference E-TFCIs

9.2.2.78 Reference E-TFCI Power Offset

The Reference E-TFCI Power Offset is used in UTDOA positioning method indicating how to calculate the reference E-TFC gain factor.

Table 130

IE/Group Name	Presence	Range	IE Type and Reference	Semantics Description
Reference E-TFCI Power Offset			INTEGER (0..8)	According to mapping in ref. [17] subclause 4.2.1.3

9.2.2.79 E-TTI

The E-TTI parameter is used in UTDOA positioning method indicating the Transmission Time Interval for E-DPCH operation.

Table 131

IE/Group Name	Presence	Range	IE Type and Reference	Semantics Description
E-TTI			ENUMERATED (2ms, 10ms, ...)	

9.2.2.80 E-DPCCH Power Offset

The E-DPCCH Power Offset is used in UTDOA positioning method indicating how to calculate the E-DPCCH gain factor.

Table 132

IE/Group Name	Presence	Range	IE Type and Reference	Semantics Description
E-DPCCH Power Offset			INTEGER (0..8)	According to mapping in ref. [17] subclause 4.2.1.3.

9.2.2.81 Cell Parameter ID

The Cell Parameter ID identifies unambiguously the Code Groups, Scrambling Codes, Midambles and Toffset (see ref. [18]).

Table 133

IE/Group Name	Presence	Range	IE Type and Reference	Semantics Description
Cell Parameter ID			INTEGER (0..127,...)	

9.2.2.82 TFCI Coding

The TFCI Coding describes the way how the TFCI bits are coded. By default 1 TFCI bit is coded with 4 bits, 2 TFCI bits are coded with 8 bits, 3-5 TFCI bits are coded with 16 bits and 6-10 TFCI bits are coded with 32 bits.

Table 134

IE/Group Name	Presence	Range	IE Type and Reference	Semantics Description
TFCI Coding			ENUMERATED (4, 8, 16, 32,...)	

9.2.2.83 Repetition Length

The Repetition Length represents the number of consecutive Radio Frames inside a Repetition Period in which the same Time Slot is assigned to the same Physical Channel see ref. [4].

Table 135

IE/Group Name	Presence	Range	IE Type and Reference	Semantics Description
Repetition Length			INTEGER (1..63)	

9.2.2.84 Repetition Period

The Repetition Period represents the number of consecutive Radio Frames after which the same assignment scheme of Time Slots to a Physical Channel is repeated. This means that if the Time Slot K is assigned to a physical channel in the Radio Frame J , it is assigned to the same physical channel also in all the Radio Frames $J+n*Repetition\ Period$ (where n is an integer) see ref. [4].

Table 136

IE/Group Name	Presence	Range	IE Type and Reference	Semantics Description
Repetition Period			ENUMERATED (1, 2, 4, 8, 16, 32, 64,...)	

9.2.2.85 TDD DPCH Offset

The Offset represents the phase information for the allocation of a group of dedicated physical channels. The first range is used when a starting offset is not required and the TDD Physical channel offset for each DPCH in the CCTrCH shall be directly determined from the TDD DPCH Offset. The second range is used when a starting offset is required. The TDD DPCH Offset shall map to the CFN and the TDD Physical Channel Offset for each DPCH in this CCTrCH shall be calculated by TDD DPCH Offset *mod* Repetition period, see ref. [4].

Table 137

IE/Group Name	Presence	Range	IE Type and Reference	Semantics Description
CHOICE <i>Offset Type</i>				
> <i>Initial Offset</i>				
>>TDD DPCH Offset Value	M		INTEGER (0..255)	
> <i>No Initial Offset</i>				
>>TDD DPCH Offset Value	M		INTEGER (0..63)	

9.2.2.86 UL Timeslot Information

The *UL Timeslot Information* IE provides information on the time slot allocation for an UL DPCH.

Table 138

IE/Group Name	Presence	Range	IE Type and Reference	Semantics Description
UL Timeslot Information		1..<maxno ofULts>		
>Time Slot	M		9.2.2.87	
>Midamble Shift And Burst Type	M		9.2.2.88	
>TFCI Presence	M		9.2.2.89	
>UL Code Information	M		9.2.2.90	

9.2.2.87 Time Slot

The Time Slot represents the minimum time interval inside a Radio Frame that can be assigned to a Physical Channel.

Table 139

IE/Group Name	Presence	Range	IE Type and Reference	Semantics Description
Time Slot			INTEGER (0..14)	

9.2.2.88 Midamble Shift And Burst Type

This information element indicates burst type and midamble allocation.

The 256 chip midamble supports 3 different time shifts, the 512 chips midamble may support 8 or even 16 time shifts.

Three different midamble allocation schemes exist:

Default midamble: the midamble shift is selected by layer 1 depending on the associated channelisation code (DL and UL)

Common midamble: the midamble shift is chosen by layer 1 depending on the number of channelisation codes (possible in DL only)

UE specific midamble: a UE specific midamble is explicitly assigned (DL and UL)

Table 140

IE/Group Name	Presence	Range	IE Type and Reference	Semantics Description
CHOICE <i>Burst Type</i>				
> <i>Type1</i>				
>>Midamble Configuration Burst Type 1 And 3	M		INTEGER (4, 8, 16)	As defined in [19]
>>CHOICE <i>Midamble Allocation Mode</i>	M			
>>>Default <i>Midamble</i>			NULL	
>>>Common <i>Midamble</i>			NULL	
>>>UE Specific <i>Midamble</i>				
>>Midamble Shift Long	M		INTEGER (0..15)	
> <i>Type2</i>				
>>Midamble Configuration Burst Type 2	M		INTEGER (3,6)	As defined in [19]
>>CHOICE <i>Midamble Allocation Mode</i>	M			
>>>Default <i>Midamble</i>			NULL	
>>>Common <i>Midamble</i>			NULL	
>>>UE Specific <i>Midamble</i>				
>>Midamble Shift Short	M		INTEGER (0..5)	
> <i>Type3</i>				UL only
>>Midamble Configuration Burst Type 1 And 3	M		INTEGER (4, 8, 16)	As defined in [19]
>>CHOICE <i>Midamble Allocation Mode</i>	M			
>>>Default <i>Midamble</i>			NULL	
>>>UE Specific <i>Midamble</i>				
>>Midamble Shift Long	M		INTEGER (0..15)	

9.2.2.89 TFCI Presence

The TFCI Presence parameter indicates whether the TFCI shall be included. [TDD - If it is present in the timeslot, it will be mapped to the channelisation code defined by [19].]

Table 141

IE/Group Name	Presence	Range	IE Type and Reference	Semantics Description
TFCI presence			ENUMERATED (Present, Not Present)	

9.2.2.90 TDD UL Code Information

The *TDD UL Code Information* IE provides information for UL Codes that have been established.

Table 142

IE/Group Name	Presence	Range	IE Type and Reference	Semantics Description
TDD UL Code Information		1..<maxno ofDPCHs>		
>TDD Channelisation Code	M		9.2.2.91	

Table 143

Range Bound	Explanation
maxnoofDPCHs	Maximum number of DPCHs in one CCTrCH

9.2.2.91 TDD Channelisation Code

The Channelisation Code Number indicates which Channelisation Code is used for a given Physical Channel. In TDD the Channelisation Code is an Orthogonal Variable Spreading Factor code, that can have a spreading factor of 1, 2, 4, 8 or 16.

Table 144

IE/Group Name	Presence	Range	IE Type and Reference	Semantics Description
TDD Channelisation Code			ENUMERATED ((1/1), (2/1), (2/2), (4/1), .. (4/4), (8/1), .. (8/8), (16/1), .. (16/16),...)	

9.2.2.92 Special Burst Scheduling

This information element expresses the number of frames between special burst transmissions during DTX.

Table 145

IE/Group Name	Presence	Range	IE Type and Reference	Semantics Description
Special Burst Scheduling			INTEGER (1..256)	Number of frames between special burst transmission during DTX

9.2.2.93 Max PRACH Midamble Shift

Indicates the maximum number of Midamble shifts to be used in a cell.

Table 146

IE/Group Name	Presence	Range	IE Type and Reference	Semantics Description
Max PRACH Midamble Shift			ENUMERATED (4, 8,...)	

9.2.2.94 PRACH Midamble

The PRACH Midamble indicates if only the Basic Midamble Sequence or also the time-inverted Midamble Sequence is used.

Table 147

IE/Group Name	Presence	Range	IE Type and Reference	Semantics Description
PRACH Midamble			ENUMERATED (Inverted, Direct, ...)	

9.2.2.95 USCH Parameters

In Cell-FACH state, when the UE supports the USCH, and the CRNC is equal to the SRNC, the UE may be given periodic allocations on the uplink shared channel. Furthermore, the UE may also be configured to generate special bursts instead of uplink shared channel transmissions. This information element defines the uplink shared channel transmissions.

Table 148

IE/Group Name	Presence	Range	IE Type and Reference	Semantics Description
Cell Parameter ID	M		9.2.2.81	
TFCI Coding	M		9.2.2.82	
Puncture Limit	M		9.2.2.76	
Repetition Period	M		9.2.2.84	This is the scheduling interval on the USCH.
USCH Scheduling Offset	M		9.2.2.96	
UL Timeslot Information	M		9.2.2.86	
TFCS	1..<maxTF C>			
>CTFC	M		9.2.2.49	
TrCH Information List	1..<maxTr CH>			
>UL TrCH Information	M		9.2.2.60	

Table 149

Range bound	Explanation
maxTFC	Maximum number of TFC. The value is 1024.
maxTrCH	Maximum number of Transport Channels. The value is 32.

9.2.2.96 USCH Scheduling Offset

This information element indicates the offset relative to CFN=0 that the transmission on the uplink shared channel shall take place.

Table 150

IE/Group Name	Presence	Range	IE Type and Reference	Semantics Description
USCH scheduling offset			INTEGER(0..255)	

9.3 Message and Information Element Abstract Syntax (with ASN.1)

9.3.0 General

PCAP ASN.1 definition conforms with [7], [8], and [9].

The ASN.1 definition specifies the structure and content of PCAP messages. PCAP messages can contain any IEs specified in the object set definitions for that message without the order or number of occurrence being restricted by ASN.1. However, for this version of the standard, a sending entity shall construct a PCAP message according to the PDU definitions module and with the following additional rules (Note that in the following IE means an IE in the object set with an explicit id. If one IE needed to appear more than once in one object set, then the different occurrences have different IE ids):

- IEs shall be ordered (in an IE container) in the order they appear in object set definitions.
- Object set definitions specify how many times IEs may appear. An IE shall appear exactly once if the presence field in an object has value "mandatory". An IE may appear at most once if the presence field in an object has value "optional" or "conditional". If in a tabular format there is multiplicity specified for an IE (i.e. an IE list) then in the corresponding ASN.1 definition the list definition is separated into two parts. The first part defines an IE container list where the list elements reside. The second part defines list elements. The IE container list appears as an IE of its own. For this version of the standard an IE container list may contain only one kind of list elements.

If a PCAP message that is not constructed as defined above is received, this shall be considered as Abstract Syntax Error, and the message shall be handled as defined for Abstract Syntax Error in clause 10.3.6.

Clause 9.3 presents the Abstract Syntax of PCAP protocol with ASN.1. In case there is contradiction between the ASN.1 definition in this clause and the tabular format in clauses 9.1 and 9.2, the ASN.1 shall take precedence, except for the definition of conditions for the presence of conditional elements, where the tabular format shall take precedence.

9.3.1 Usage of private message mechanism for non-standard use

The private message mechanism for non-standard use may be used:

- for special operator- (and/or vendor) specific features considered not to be part of the basic functionality, i.e. the functionality required for a complete and high-quality specification in order to guarantee multivendor interoperability;
- by vendors for research purposes, e.g. to implement and evaluate new algorithms/features before such features are proposed for standardisation.

The private message mechanism shall not be used for basic functionality. Such functionality shall be standardised.

9.3.2 Elementary Procedure Definitions

```
-- *****
--
-- Elementary Procedure definitions
--
-- *****

PCAP-PDU-Descriptions {
itu-t (0) identified-organization (4) etsi (0) mobileDomain (0)
umts-Access (20) modules (3) pcap(4) version1 (1) pcap-PDU-Descriptions (0)}

DEFINITIONS AUTOMATIC TAGS ::=

BEGIN

-- *****
--
-- IE parameter types from other modules.
--
```

```

-- *****
IMPORTS
    Criticality,
    ProcedureCode,
    TransactionID
FROM PCAP-CommonDataTypes

    PositionCalculationRequest,
    PositionCalculationResponse,
    PositionCalculationFailure,
    InformationExchangeInitiationRequest,
    InformationExchangeInitiationResponse,
    InformationExchangeInitiationFailure,
    InformationReport,
    InformationExchangeTerminationRequest,
    InformationExchangeFailureIndication,
    ErrorIndication,
    PrivateMessage,
    PositionInitiationRequest,
    PositionInitiationResponse,
    PositionInitiationFailure,
    PositionActivationRequest,
    PositionActivationResponse,
    PositionActivationFailure,
    PositionParameterModification,
    Abort

FROM PCAP-PDU-Contents

    id-PositionCalculation,
    id-InformationExchangeInitiation,
    id-InformationReporting,
    id-InformationExchangeTermination,
    id-InformationExchangeFailure,
    id-ErrorIndication,
    id-privateMessage,
    id-PositionInitiation,
    id-PositionActivation,
    id-PositionParameterModification,
    id-Abort
FROM PCAP-Constants;

-- *****
--
-- Interface Elementary Procedure Class
--
-- *****

PCAP-ELEMENTARY-PROCEDURE ::= CLASS {
    &InitiatingMessage           ,
    &SuccessfulOutcome           OPTIONAL,
    &UnsuccessfulOutcome         OPTIONAL,
    &Outcome                     OPTIONAL,
    &procedureCode               ProcedureCode  UNIQUE,
    &criticality                  Criticality   DEFAULT ignore
}

WITH SYNTAX {
    INITIATING MESSAGE           &InitiatingMessage
    [SUCCESSFUL OUTCOME          &SuccessfulOutcome]
    [UNSUCCESSFUL OUTCOME        &UnsuccessfulOutcome]
    [OUTCOME                     &Outcome]
    PROCEDURE CODE               &procedureCode
    [CRITICALITY                 &criticality]
}

-- *****
--
-- Interface PDU definitions
--
-- *****

PCAP-PDU ::= CHOICE {
    initiatingMessage           InitiatingMessage,
    successfulOutcome           SuccessfulOutcome,
    unsuccessfulOutcome         UnsuccessfulOutcome,
    outcome                     Outcome,
}

```

```

}
...
}

InitiatingMessage ::= SEQUENCE {
    procedureCode    PCAP-ELEMENTARY-PROCEDURE.&procedureCode    ( {PCAP-ELEMENTARY-PROCEDURES} ),
    criticality      PCAP-ELEMENTARY-PROCEDURE.&criticality      ( {PCAP-ELEMENTARY-
PROCEDURES}@@procedureCode} ),
    transactionID    TransactionID,
    value            PCAP-ELEMENTARY-PROCEDURE.&InitiatingMessage ( {PCAP-ELEMENTARY-
PROCEDURES}@@procedureCode} )
}

SuccessfulOutcome ::= SEQUENCE {
    procedureCode    PCAP-ELEMENTARY-PROCEDURE.&procedureCode    ( {PCAP-ELEMENTARY-PROCEDURES} ),
    criticality      PCAP-ELEMENTARY-PROCEDURE.&criticality      ( {PCAP-ELEMENTARY-
PROCEDURES}@@procedureCode} ),
    transactionID    TransactionID,
    value            PCAP-ELEMENTARY-PROCEDURE.&SuccessfulOutcome ( {PCAP-ELEMENTARY-
PROCEDURES}@@procedureCode} )
}

UnsuccessfulOutcome ::= SEQUENCE {
    procedureCode    PCAP-ELEMENTARY-PROCEDURE.&procedureCode    ( {PCAP-ELEMENTARY-PROCEDURES} ),
    criticality      PCAP-ELEMENTARY-PROCEDURE.&criticality      ( {PCAP-ELEMENTARY-
PROCEDURES}@@procedureCode} ),
    transactionID    TransactionID,
    value            PCAP-ELEMENTARY-PROCEDURE.&UnsuccessfulOutcome ( {PCAP-ELEMENTARY-
PROCEDURES}@@procedureCode} )
}

Outcome ::= SEQUENCE {
    procedureCode    PCAP-ELEMENTARY-PROCEDURE.&procedureCode    ( {PCAP-ELEMENTARY-PROCEDURES} ),
    criticality      PCAP-ELEMENTARY-PROCEDURE.&criticality      ( {PCAP-ELEMENTARY-
PROCEDURES}@@procedureCode} ),
    transactionID    TransactionID,
    value            PCAP-ELEMENTARY-PROCEDURE.&Outcome          ( {PCAP-ELEMENTARY-
PROCEDURES}@@procedureCode} )
}

-- *****
--
-- Interface Elementary Procedure List
--
-- *****

PCAP-ELEMENTARY-PROCEDURES PCAP-ELEMENTARY-PROCEDURE ::= {
    PCAP-ELEMENTARY-PROCEDURES-CLASS-1 |
    PCAP-ELEMENTARY-PROCEDURES-CLASS-2 ,
    ...
}

PCAP-ELEMENTARY-PROCEDURES-CLASS-1 PCAP-ELEMENTARY-PROCEDURE ::= {
    positionCalculation |
    informationExchangeInitiation,
    ...,
    positionInitiation |
    positionActivation
}

PCAP-ELEMENTARY-PROCEDURES-CLASS-2 PCAP-ELEMENTARY-PROCEDURE ::= {
    informationReporting |
    informationExchangeTermination |
    informationExchangeFailure |
    errorIndication,
    privateMessage,
    ...,
    positionParameterModification |
    abort
}

-- *****
--
-- Interface Elementary Procedures
--

```



```

-- *****
positionCalculation PCAP-ELEMENTARY-PROCEDURE ::= {
    INITIATING MESSAGE      PositionCalculationRequest
    SUCCESSFUL OUTCOME      PositionCalculationResponse
    UNSUCCESSFUL OUTCOME    PositionCalculationFailure
    PROCEDURE CODE          id-PositionCalculation
    CRITICALITY              reject
}

informationExchangeInitiation PCAP-ELEMENTARY-PROCEDURE ::= {
    INITIATING MESSAGE      InformationExchangeInitiationRequest
    SUCCESSFUL OUTCOME      InformationExchangeInitiationResponse
    UNSUCCESSFUL OUTCOME    InformationExchangeInitiationFailure
    PROCEDURE CODE          id-InformationExchangeInitiation
    CRITICALITY              reject
}

positionInitiation PCAP-ELEMENTARY-PROCEDURE ::= {
    INITIATING MESSAGE      PositionInitiationRequest
    SUCCESSFUL OUTCOME      PositionInitiationResponse
    UNSUCCESSFUL OUTCOME    PositionInitiationFailure
    PROCEDURE CODE          id-PositionInitiation
    CRITICALITY              reject
}

positionActivation PCAP-ELEMENTARY-PROCEDURE ::= {
    INITIATING MESSAGE      PositionActivationRequest
    SUCCESSFUL OUTCOME      PositionActivationResponse
    UNSUCCESSFUL OUTCOME    PositionActivationFailure
    PROCEDURE CODE          id-PositionActivation
    CRITICALITY              reject
}

informationReporting PCAP-ELEMENTARY-PROCEDURE ::= {
    INITIATING MESSAGE      InformationReport
    PROCEDURE CODE          id-InformationReporting
    CRITICALITY              ignore
}

informationExchangeTermination PCAP-ELEMENTARY-PROCEDURE ::= {
    INITIATING MESSAGE      InformationExchangeTerminationRequest
    PROCEDURE CODE          id-InformationExchangeTermination
    CRITICALITY              ignore
}

informationExchangeFailure PCAP-ELEMENTARY-PROCEDURE ::= {
    INITIATING MESSAGE      InformationExchangeFailureIndication
    PROCEDURE CODE          id-InformationExchangeFailure
    CRITICALITY              ignore
}

errorIndication PCAP-ELEMENTARY-PROCEDURE ::= {
    INITIATING MESSAGE      ErrorIndication
    PROCEDURE CODE          id-ErrorIndication
    CRITICALITY              ignore
}

privateMessage PCAP-ELEMENTARY-PROCEDURE ::= {
    INITIATING MESSAGE      PrivateMessage
    PROCEDURE CODE          id-privateMessage
    CRITICALITY              ignore
}

positionParameterModification PCAP-ELEMENTARY-PROCEDURE ::= {
    INITIATING MESSAGE      PositionParameterModification
    PROCEDURE CODE          id-PositionParameterModification
    CRITICALITY              ignore
}

abort PCAP-ELEMENTARY-PROCEDURE ::= {
    INITIATING MESSAGE      Abort
    PROCEDURE CODE          id-Abort
}

```

```

    CRITICALITY          ignore
}
END

```

9.3.3 PDU Definitions

```

-- *****
--
-- PDU definitions for PCAP.
--
-- *****

PCAP-PDU-Contents {
itu-t (0) identified-organization (4) etsi (0) mobileDomain (0)
umts-Access (20) modules (3) pcap(4) version1 (1) pcap-PDU-Contents (1) }

DEFINITIONS AUTOMATIC TAGS ::=

BEGIN

-- *****
--
-- IE parameter types from other modules.
--
-- *****

IMPORTS
    Cause,
    CriticalityDiagnostics,
    GPS-UTRAN-TRU,
    InformationExchangeID,
    InformationReportCharacteristics,
    InformationType,
    MeasuredResultsList,
    RequestedDataValue,
    RequestedDataValueInformation,
    UE-PositionEstimate,
    CellId-MeasuredResultsSets,
    OTDOA-MeasurementGroup,
    AccuracyFulfilmentIndicator,
    HorizontalAccuracyCode,
    VerticalAccuracyCode,
    RequestType,
    UE-PositioningCapability,
    UC-ID,
    ResponseTime,
    PositioningPriority,
    ClientType,
    PositioningMethod,
    UTDOAPositioning,
    GPSAssistanceData,
    OTDOAAssistanceData,
    UTDOA-Group,
    Positioning-ResponseTime,
    EnvironmentCharacterisation,
    PositionData

FROM PCAP-IEs

    TransactionID
FROM PCAP-CommonDataTypes

    ProtocolExtensionContainer{},
    ProtocolIE-ContainerList{},
    ProtocolIE-Container{},
    PrivateIE-Container{},
    PCAP-PRIVATE-IES,
    PCAP-PROTOCOL-EXTENSION,
    PCAP-PROTOCOL-IES
FROM PCAP-Containers

    id-Cause,
    id-CriticalityDiagnostics,
    id-GPS-UTRAN-TRU,
    id-InformationExchangeID,
    id-InformationExchangeObjectType-InfEx-Rprt,

```

```

id-InformationExchangeObjectType-InfEx-Rqst,
id-InformationExchangeObjectType-InfEx-Rsp,
id-InformationReportCharacteristics,
id-InformationType,
id-GPS-MeasuredResultsList,
id-RequestedDataValue,
id-RequestedDataValueInformation,
id-TransactionID,
id-UE-PositionEstimate,
id-CellId-MeasuredResultsSets,
id-OTDOA-MeasurementGroup,
id-AccuracyFulfilmentIndicator,
id-HorizontalAccuracyCode,
id-VerticalAccuracyCode,
id-RequestType,
id-UE-PositioningCapability,
id-UC-id,
id-ResponseTime,
id-PositioningPriority,
id-ClientType,
id-PositioningMethod,
id-UTDOA-Positioning,
id-GPSAssistanceData,
id-OTDOAAssistanceData,
id-UTDOA-Group,
id-Positioning-ResponseTime,
id-EnvironmentCharacterisation,
id-PositionData

```

FROM PCAP-Constants;

```

-- *****
--
-- POSITION CALCULATION REQUEST
--
-- *****

```

```

PositionCalculationRequest ::= SEQUENCE {
    protocolIEs          ProtocolIE-Container          { {PositionCalculationRequestIEs} },
    protocolExtensions  ProtocolExtensionContainer { {PositionCalculationRequestExtensions} }
    OPTIONAL,
    ...
}

```

```

PositionCalculationRequestIEs PCAP-PROTOCOL-IES ::= {
    { ID id-UE-PositionEstimate          CRITICALITY reject  TYPE UE-PositionEstimate
      PRESENCE optional } |
    { ID id-GPS-MeasuredResultsList      CRITICALITY reject  TYPE MeasuredResultsList
      PRESENCE optional },
    ...
}

```

```

PositionCalculationRequestExtensions PCAP-PROTOCOL-EXTENSION ::= {
    { ID id-CellId-MeasuredResultsSets    CRITICALITY reject  EXTENSION CellId-MeasuredResultsSets
      PRESENCE optional } |
    { ID id-OTDOA-MeasurementGroup        CRITICALITY reject  EXTENSION OTDOA-MeasurementGroup
      PRESENCE optional } |
    { ID id-HorizontalAccuracyCode        CRITICALITY ignore   EXTENSION HorizontalAccuracyCode
      PRESENCE optional } |
    { ID id-VerticalAccuracyCode          CRITICALITY ignore   EXTENSION VerticalAccuracyCode
      PRESENCE optional } |
    { ID id-UTDOA-Group                   CRITICALITY reject   EXTENSION UTDOA-Group
      PRESENCE optional } |
    { ID id-Positioning-ResponseTime      CRITICALITY ignore   EXTENSION Positioning-ResponseTime
      PRESENCE optional },
    ...
}

```

```

-- *****
--
-- POSITION CALCULATION RESPONSE
--
-- *****

```

```

PositionCalculationResponse ::= SEQUENCE {
    protocolIEs          ProtocolIE-Container          { {PositionCalculationResponseIEs} },

```

```

    protocolExtensions ProtocolExtensionContainer { {PositionCalculationResponseExtensions} }
    OPTIONAL,
    ...
}

PositionCalculationResponseIEs PCAP-PROTOCOL-IES ::= {
    { ID id-UE-PositionEstimate          CRITICALITY ignore  TYPE UE-PositionEstimate          PRESENCE
mandatory } |
    { ID id-CriticalityDiagnostics       CRITICALITY ignore  TYPE CriticalityDiagnostics       PRESENCE
optional  },
    ...
}

PositionCalculationResponseExtensions PCAP-PROTOCOL-EXTENSION ::= {
    { ID id-AccuracyFulfilmentIndicator CRITICALITY ignore  EXTENSION AccuracyFulfilmentIndicator
PRESENCE optional},
    ...
}

-- *****
--
-- POSITION CALCULATION FAILURE
--
-- *****

PositionCalculationFailure ::= SEQUENCE {
    protocolIEs          ProtocolIE-Container          { {PositionCalculationFailureIEs} },
    protocolExtensions  ProtocolExtensionContainer { {PositionCalculationFailureExtensions} }
    OPTIONAL,
    ...
}

PositionCalculationFailureIEs PCAP-PROTOCOL-IES ::= {
    { ID id-Cause          CRITICALITY ignore  TYPE Cause          PRESENCE
mandatory} |
    { ID id-CriticalityDiagnostics CRITICALITY ignore  TYPE CriticalityDiagnostics PRESENCE
optional },
    ...
}

PositionCalculationFailureExtensions PCAP-PROTOCOL-EXTENSION ::= {
    ...
}

-- *****
--
-- INFORMATION EXCHANGE INITIATION REQUEST
--
-- *****

InformationExchangeInitiationRequest ::= SEQUENCE {
    protocolIEs          ProtocolIE-Container          {{InformationExchangeInitiationRequest-IEs}},
    protocolExtensions  ProtocolExtensionContainer {{InformationExchangeInitiationRequest-
Extensions}}
    OPTIONAL,
    ...
}

InformationExchangeInitiationRequest-IEs PCAP-PROTOCOL-IES ::= {
    { ID id-InformationExchangeID          CRITICALITY reject  TYPE
InformationExchangeID          PRESENCE  mandatory }|
    { ID id-InformationExchangeObjectType-InfEx-Rqst CRITICALITY reject  TYPE
InformationExchangeObjectType-InfEx-Rqst PRESENCE mandatory }|
    -- This IE represents both the Information Exchange Object Type IE and the choice based on the
Information Exchange Object Type
    -- as described in the tabular message format in clause 9.1.
    { ID id-InformationType          CRITICALITY reject  TYPE InformationType
PRESENCE  mandatory }|
    { ID id-InformationReportCharacteristics CRITICALITY reject  TYPE
InformationReportCharacteristics PRESENCE  mandatory }|
    { ID id-GPS-UTRAN-TRU          CRITICALITY reject  TYPE GPS-UTRAN-TRU
PRESENCE conditional },
    -- This IE shall be present if the information requested in the Information Type IE contains
GPS-related data
    ...
}

InformationExchangeInitiationRequest-Extensions PCAP-PROTOCOL-EXTENSION ::= {

```

```

}
...
}
InformationExchangeObjectType-InfEx-Rqst ::= CHOICE {
    referencePosition          RefPosition-InfEx-Rqst,
    ...
}

RefPosition-InfEx-Rqst ::= SEQUENCE {
    referencePositionEstimate  UE-PositionEstimate,
    iE-Extensions              ProtocolExtensionContainer  { { RefPositionItem-InfEx-Rqst-
ExtIEs} }          OPTIONAL,
    ...
}

RefPositionItem-InfEx-Rqst-ExtIEs PCAP-PROTOCOL-EXTENSION ::= {
    ...
}

-- *****
--
-- INFORMATION EXCHANGE INITIATION RESPONSE
--
-- *****

InformationExchangeInitiationResponse ::= SEQUENCE {
    protocolIEs                ProtocolIE-Container  {{InformationExchangeInitiationResponse-IEs}},
    protocolExtensions          ProtocolExtensionContainer  {{InformationExchangeInitiationResponse-
Extensions}}          OPTIONAL,
    ...
}

InformationExchangeInitiationResponse-IEs PCAP-PROTOCOL-IES ::= {
    { ID      id-InformationExchangeID                CRITICALITY ignore TYPE
InformationExchangeID                PRESENCE mandatory }|
    { ID      id-InformationExchangeObjectType-InfEx-Rsp  CRITICALITY ignore TYPE
InformationExchangeObjectType-InfEx-Rsp  PRESENCE optional }|
    { ID      id-CriticalityDiagnostics                CRITICALITY ignore TYPE
CriticalityDiagnostics                PRESENCE optional },
    ...
}

InformationExchangeInitiationResponse-Extensions PCAP-PROTOCOL-EXTENSION ::= {
    ...
}

InformationExchangeObjectType-InfEx-Rsp ::= CHOICE {
    referencePosition          RefPosition-InfEx-Rsp,
    ...
}

RefPosition-InfEx-Rsp ::= SEQUENCE {
    requestedDataValue          RequestedDataValue,
    iE-Extensions              ProtocolExtensionContainer  { { RefPositionItem-InfEx-Rsp-
ExtIEs} }          OPTIONAL,
    ...
}

RefPositionItem-InfEx-Rsp-ExtIEs PCAP-PROTOCOL-EXTENSION ::= {
    ...
}

-- *****
--
-- INFORMATION EXCHANGE INITIATION FAILURE
--
-- *****

InformationExchangeInitiationFailure ::= SEQUENCE {
    protocolIEs                ProtocolIE-Container  {{InformationExchangeInitiationFailure-IEs}},
    protocolExtensions          ProtocolExtensionContainer  {{InformationExchangeInitiationFailure-
Extensions}}          OPTIONAL,
    ...
}

```

```

InformationExchangeInitiationFailure-IEs PCAP-PROTOCOL-IES ::= {
  { ID id-InformationExchangeID          CRITICALITY ignore  TYPE InformationExchangeID
  PRESENCE mandatory }|
  { ID id-Cause                          CRITICALITY ignore  TYPE Cause
  PRESENCE mandatory }|
  { ID id-CriticalityDiagnostics          CRITICALITY ignore  TYPE CriticalityDiagnostics
  PRESENCE optional },
  ...
}

InformationExchangeInitiationFailure-Extensions PCAP-PROTOCOL-EXTENSION ::= {
  ...
}

-- *****
--
-- POSITION INITIATION REQUEST
--
-- *****

PositionInitiationRequest ::= SEQUENCE {
  protocolIEs          ProtocolIE-Container    { {PositionInitiationRequestIEs} },
  protocolExtensions   ProtocolExtensionContainer { {PositionInitiationRequestExtensions} }
  OPTIONAL,
  ...
}

PositionInitiationRequestIEs PCAP-PROTOCOL-IES ::= {
  { ID id-RequestType          CRITICALITY reject  TYPE RequestType          PRESENCE
  mandatory } |
  { ID id-UE-PositioningCapability  CRITICALITY reject  TYPE UE-PositioningCapability  PRESENCE
  mandatory } |
  { ID id-UC-id                CRITICALITY reject  TYPE UC-ID                PRESENCE
  mandatory } |
  { ID id-VerticalAccuracyCode    CRITICALITY ignore  TYPE VerticalAccuracyCode    PRESENCE
  optional } |
  { ID id-ResponseTime           CRITICALITY ignore  TYPE ResponseTime           PRESENCE
  optional } |
  { ID id-PositioningPriority     CRITICALITY ignore  TYPE PositioningPriority     PRESENCE
  optional } |
  { ID id-ClientType             CRITICALITY ignore  TYPE ClientType             PRESENCE
  optional },
  ...
}

PositionInitiationRequestExtensions PCAP-PROTOCOL-EXTENSION ::= {
  ...
}

-- *****
--
-- POSITION INITIATION RESPONSE
--
-- *****

PositionInitiationResponse ::= SEQUENCE {
  protocolIEs          ProtocolIE-Container    { {PositionInitiationResponseIEs} },
  protocolExtensions   ProtocolExtensionContainer { {PositionInitiationResponseExtensions} }
  OPTIONAL,
  ...
}

PositionInitiationResponseIEs PCAP-PROTOCOL-IES ::= {
  { ID id-UE-PositionEstimate     CRITICALITY reject  TYPE UE-PositionEstimate     PRESENCE
  mandatory } |
  { ID id-PositionData            CRITICALITY ignore  TYPE PositionData            PRESENCE
  mandatory } |
  { ID id-AccuracyFulfilmentIndicator  CRITICALITY ignore  TYPE AccuracyFulfilmentIndicator
  PRESENCE optional },
  ...
}

PositionInitiationResponseExtensions PCAP-PROTOCOL-EXTENSION ::= {
  ...
}

```

```

-- *****
--
-- POSITION INITIATION FAILURE
--
-- *****

PositionInitiationFailure ::= SEQUENCE {
    protocolIEs          ProtocolIE-Container          { {PositionInitiationFailureIEs} },
    protocolExtensions  ProtocolExtensionContainer { {PositionInitiationFailureExtensions} }
    OPTIONAL,
    ...
}

PositionInitiationFailureIEs PCAP-PROTOCOL-IES ::= {
    { ID id-Cause          CRITICALITY ignore  TYPE Cause          PRESENCE
mandatory } |
    { ID id-CriticalityDiagnostics CRITICALITY ignore  TYPE CriticalityDiagnostics PRESENCE
optional },
    ...
}

PositionInitiationFailureExtensions PCAP-PROTOCOL-EXTENSION ::= {
    ...
}

-- *****
--
-- POSITION ACTIVATION REQUEST
--
-- *****

PositionActivationRequest ::= SEQUENCE {
    protocolIEs          ProtocolIE-Container          { {PositionActivationRequestIEs} },
    protocolExtensions  ProtocolExtensionContainer { {PositionActivationRequestExtensions} }
    OPTIONAL,
    ...
}

PositionActivationRequestIEs PCAP-PROTOCOL-IES ::= {
    { ID id-PositioningMethod          CRITICALITY reject  TYPE PositioningMethod
PRESENCE mandatory } |
    { ID id-Positioning-ResponseTime  CRITICALITY ignore  TYPE Positioning-ResponseTime
PRESENCE mandatory } |
    { ID id-PositioningPriority        CRITICALITY ignore  TYPE PositioningPriority
PRESENCE optional } |
    { ID id-EnvironmentCharacterisation CRITICALITY ignore  TYPE EnvironmentCharacterisation
PRESENCE optional } |
    { ID id-UTDOAPositioning          CRITICALITY reject  TYPE UTDOAPositioning
PRESENCE optional } |
    { ID id-GPSAssistanceData         CRITICALITY reject  TYPE GPSAssistanceData
PRESENCE optional } |
    { ID id-OTDOAAssistanceData       CRITICALITY reject  TYPE OTDOAAssistanceData
PRESENCE optional },
    ...
}

PositionActivationRequestExtensions PCAP-PROTOCOL-EXTENSION ::= {
    ...
}

-- *****
--
-- POSITION ACTIVATION RESPONSE
--
-- *****

PositionActivationResponse ::= SEQUENCE {
    protocolIEs          ProtocolIE-Container          { {PositionActivationResponseIEs} },
    protocolExtensions  ProtocolExtensionContainer { {PositionActivationResponseExtensions} }
    OPTIONAL,
    ...
}

PositionActivationResponseIEs PCAP-PROTOCOL-IES ::= {
    { ID id-UE-PositionEstimate        CRITICALITY ignore  TYPE UE-PositionEstimate
PRESENCE optional } |

```

```

    { ID id-GPS-MeasuredResultsList          CRITICALITY reject  TYPE MeasuredResultsList
    PRESENCE optional } |
    { ID id-CellId-MeasuredResultsSets       CRITICALITY reject  TYPE CellId-MeasuredResultsSets
    PRESENCE optional } |
    { ID id-OTDOA-MeasurementGroup          CRITICALITY reject  TYPE OTDOA-MeasurementGroup
    PRESENCE optional } |
    { ID id-UTDOA-Group                      CRITICALITY reject  TYPE UTDOA-Group
    PRESENCE optional },
    ...
}

PositionActivationResponseExtensions PCAP-PROTOCOL-EXTENSION ::= {
    ...
}

-- *****
--
-- POSITION ACTIVATION FAILURE
--
-- *****

PositionActivationFailure ::= SEQUENCE {
    protocolIEs          ProtocolIE-Container          { {PositionActivationFailureIEs} },
    protocolExtensions  ProtocolExtensionContainer { {PositionActivationFailureExtensions} }
    OPTIONAL,
    ...
}

PositionActivationFailureIEs PCAP-PROTOCOL-IES ::= {
    { ID id-Cause          CRITICALITY ignore  TYPE Cause          PRESENCE
    mandatory } |
    { ID id-CriticalityDiagnostics CRITICALITY ignore  TYPE CriticalityDiagnostics PRESENCE
    optional },
    ...
}

PositionActivationFailureExtensions PCAP-PROTOCOL-EXTENSION ::= {
    ...
}

-- *****
--
-- INFORMATION REPORT
--
-- *****

InformationReport ::= SEQUENCE {
    protocolIEs          ProtocolIE-Container          {{InformationReport-IEs}},
    protocolExtensions  ProtocolExtensionContainer {{InformationReport-Extensions}}
    OPTIONAL,
    ...
}

InformationReport-IEs PCAP-PROTOCOL-IES ::= {
    { ID id-InformationExchangeID          CRITICALITY ignore  TYPE
    InformationExchangeID          PRESENCE  mandatory } |
    { ID id-InformationExchangeObjectType-InfEx-Rprt CRITICALITY ignore  TYPE
    InformationExchangeObjectType-InfEx-Rprt PRESENCE  mandatory },
    ...
}

InformationReport-Extensions PCAP-PROTOCOL-EXTENSION ::= {
    ...
}

InformationExchangeObjectType-InfEx-Rprt ::= CHOICE {
    referencePosition          RefPosition-InfEx-Rprt,
    ...
}

RefPosition-InfEx-Rprt ::= SEQUENCE {
    requestedDataValueInformation RequestedDataValueInformation,
    iE-Extensions              ProtocolExtensionContainer { { RefPositionItem-InfEx-Rprt-ExtIEs
}}
    OPTIONAL,
    ...
}

```



```

}

RefPositionItem-InfEx-Rprt-ExtIEs PCAP-PROTOCOL-EXTENSION ::= {
  ...
}

-- *****
--
-- INFORMATION EXCHANGE TERMINATION REQUEST
--
-- *****

InformationExchangeTerminationRequest ::= SEQUENCE {
  protocolIEs          ProtocolIE-Container          {{InformationExchangeTerminationRequest-
IEs}},
  protocolExtensions  ProtocolExtensionContainer  {{InformationExchangeTerminationRequest-
Extensions}}  OPTIONAL,
  ...
}

InformationExchangeTerminationRequest-IEs PCAP-PROTOCOL-IES ::= {
  { ID      id-InformationExchangeID          CRITICALITY  ignore  TYPE InformationExchangeID
  PRESENCE  mandatory},
  ...
}

InformationExchangeTerminationRequest-Extensions PCAP-PROTOCOL-EXTENSION ::= {
  ...
}

-- *****
--
-- INFORMATION EXCHANGE FAILURE INDICATION
--
-- *****

InformationExchangeFailureIndication ::= SEQUENCE {
  protocolIEs          ProtocolIE-Container          {{InformationExchangeFailureIndication-
IEs}},
  protocolExtensions  ProtocolExtensionContainer  {{InformationExchangeFailureIndication-
Extensions}}  OPTIONAL,
  ...
}

InformationExchangeFailureIndication-IEs PCAP-PROTOCOL-IES ::= {
  { ID      id-InformationExchangeID          CRITICALITY  ignore          TYPE
InformationExchangeID          PRESENCE  mandatory } |
  { ID      id-Cause                          CRITICALITY  ignore          TYPE Cause
  PRESENCE  mandatory },
  ...
}

InformationExchangeFailureIndication-Extensions PCAP-PROTOCOL-EXTENSION ::= {
  ...
}

-- *****
--
-- ERROR INDICATION
--
-- *****

ErrorIndication ::= SEQUENCE {
  protocolIEs          ProtocolIE-Container          { {ErrorIndicationIEs} },
  protocolExtensions  ProtocolExtensionContainer  { {ErrorIndicationExtensions} }  OPTIONAL,
  ...
}

ErrorIndicationIEs PCAP-PROTOCOL-IES ::= {
  { ID id-Cause          CRITICALITY  ignore  TYPE Cause          PRESENCE
optional } |
  { ID id-CriticalityDiagnostics  CRITICALITY  ignore  TYPE CriticalityDiagnostics  PRESENCE
optional },
  ...
}

```

```

ErrorIndicationExtensions PCAP-PROTOCOL-EXTENSION ::= {
  ...
}

-- *****
--
-- POSITION PARAMETER MODIFICATION
--
-- *****

PositionParameterModification ::= SEQUENCE {
  protocolIEs      ProtocolIE-Container      { {PositionParameterModificationIEs} },
  protocolExtensions ProtocolExtensionContainer { {PositionParameterModificationExtensions} }
  OPTIONAL,
  ...
}

PositionParameterModificationIEs PCAP-PROTOCOL-IES ::= {

  { ID id-UC-id          CRITICALITY reject  TYPE UC-ID          PRESENCE
optional }|
  { ID id-UTDOA-Group   CRITICALITY reject  TYPE UTDOA-Group      PRESENCE
optional },
  ...
}

PositionParameterModificationExtensions PCAP-PROTOCOL-EXTENSION ::= {
  ...
}

-- *****
--
-- PRIVATE MESSAGE
--
-- *****

PrivateMessage ::= SEQUENCE {
  privateIEs      PrivateIE-Container  {{PrivateMessage-IEs}},
  ...
}

PrivateMessage-IEs PCAP-PRIVATE-IES ::= {
  ...
}

-- *****
--
-- ABORT
--
-- *****

Abort ::= SEQUENCE {
  protocolIEs      ProtocolIE-Container      { {AbortIEs} },
  protocolExtensions ProtocolExtensionContainer { {AbortExtensions} }    OPTIONAL,
  ...
}

AbortIEs PCAP-PROTOCOL-IES ::= {
  { ID id-Cause        CRITICALITY ignore  TYPE Cause          PRESENCE mandatory },
  ...
}

AbortExtensions PCAP-PROTOCOL-EXTENSION ::= {
  ...
}

END

```

9.3.4 Information Element Definitions

```
-- *****
```

```

--
-- Information Element Definitions
--
-- *****

PCAP-IEs {
itu-t (0) identified-organization (4) etsi (0) mobileDomain (0)
umts-Access (20) modules (3) pcap(4) version1 (1) pcap-IEs (2) }

DEFINITIONS AUTOMATIC TAGS ::=

BEGIN

IMPORTS
    maxNrOfErrors,
    maxSat,
    maxSatAlmanac,
    maxNrOfLevels,
    maxNrOfMeasNCell,
    maxNrOfMeasurements,
    maxNrOfPoints,
    maxNrOfExpInfo,
    maxNrOfSets,
    maxRateMatching,
    maxNrOfTFs,
    maxTTI-count,
    maxTS-1,
    maxCCTrCH,
    maxTF,
    maxTFC,
    maxPRACH,
    maxTrCH,
    maxTGPS,
    maxNoOfMeasurements,
    maxCellMeas,
    maxNrOfEDPCCH-PO-QUANTSTEPS,
    maxNrOfRefETFCI-PO-QUANTSTEPS,
    maxNrOfRefETFCIs,
    maxSet

FROM PCAP-Constants

    Criticality,
    ProcedureCode,
    ProtocolIE-ID,
    TransactionID,
    TriggeringMessage
FROM PCAP-CommonDataTypes

    ProtocolExtensionContainer{},
    PCAP-PROTOCOL-EXTENSION
FROM PCAP-Containers;

-- *****
--
-- Accuracy Fulfilment Indicator
--
-- *****

AccuracyFulfilmentIndicator ::= ENUMERATED{
    requested-Accuracy-Fulfilled,
    requested-Accuracy-Not-Fulfilled,
    ...
}

-- *****
--
-- Almanac and Satellite Health SIB
--
-- *****

AlmanacAndSatelliteHealthSIB ::= SEQUENCE {
    gpsAlmanacAndSatelliteHealth    GPS-AlmanacAndSatelliteHealth,
    satMask                          BIT STRING (SIZE (1..32)),
    lsbTOW                            BIT STRING (SIZE (8)),

```

```

        iE-Extensions
ExtIEs } } OPTIONAL,
    ...
}

AlmanacAndSatelliteHealthSIB-ExtIEs PCAP-PROTOCOL-EXTENSION ::= {
    ...
}

-- *****
--
-- Cause IE
--
-- *****

Cause ::= CHOICE {
    radioNetwork          CauseRadioNetwork,
    transport              CauseTransport,
    protocol               CauseProtocol,
    misc                   CauseMisc,
    ...
}

CauseRadioNetwork ::= ENUMERATED {
    invalid-reference-information,
    information-temporarily-not-available,
    information-provision-not-supported-for-the-object,
    position-calculation-error-invalid-GPS-measured-results,
    ...,
    position-calculation-error-invalid-CellID-measured-results,
    position-calculation-error-invalid-OTDOA-measured-results,
    position-calculation-error-AGPS-positioning-method-not-supported,
    position-calculation-error-CellID-positioning-method-not-supported,
    position-calculation-error-OTDOA-positioning-method-not-supported,
    initial-UE-position-estimate-missing,
    position-calculation-error-invalid-UTDOA-measured-results,
    position-calculation-error-UTDOA-positioning-method-not-supported,
    position-calculation-error-UTDOA-not-supported-UTRAN-cell,
    positioning-method-not-supported,
    loss-of-contact-with-UE,
    sAS-unable-to-perform-UTDOA-positioning-within-response-time,
    location-measurement-failure
}

CauseTransport ::= ENUMERATED {
    transport-resource-unavailable,
    unspecified,
    ...
}

CauseProtocol ::= ENUMERATED {
    transfer-syntax-error,
    abstract-syntax-error-reject,
    abstract-syntax-error-ignore-and-notify,
    message-not-compatible-with-receiver-state,
    semantic-error,
    unspecified,
    abstract-syntax-error-falsely-constructed-message,
    ...
}

CauseMisc ::= ENUMERATED {
    processing-overload,
    hardware-failure,
    o-and-m-intervention,
    unspecified,
    ...
}

-- *****
--
-- Cell Id Measured Results Sets
--
-- *****

CellId-MeasuredResultsSets ::= SEQUENCE (SIZE (1..maxNrOfMeasurements)) OF
    CellId-MeasuredResultsInfoList

```

```

CellId-MeasuredResultsInfoList ::= SEQUENCE (SIZE (1..maxNrOfMeasNCell)) OF
  CellId-MeasuredResultsInfo

CellId-MeasuredResultsInfo ::= SEQUENCE {
  uC-ID UC-ID,
  uTRANAccessPointPositionAltitude UTRANAccessPointPositionAltitude,
  ue-PositionEstimate UE-PositionEstimate OPTIONAL,
  roundTripTimeInfo RoundTripTimeInfo OPTIONAL, -- FDD only
  rxTimingDeviationInfo RxTimingDeviationInfo OPTIONAL, -- 3.84Mcps TDD only
  rxTimingDeviationLCRInfo RxTimingDeviationLCRInfo OPTIONAL, -- 1.28Mcps TDD only
  pathloss Pathloss OPTIONAL,
  iE-Extensions ProtocolExtensionContainer { { CellId-MeasuredResultsInfo-
ExtIEs } } OPTIONAL,
  ...
}

CellId-MeasuredResultsInfo-ExtIEs PCAP-PROTOCOL-EXTENSION ::= {
  ...
}

RoundTripTimeInfo ::= SEQUENCE {
  ue-RxTxTimeDifferenceType2 UE-RxTxTimeDifferenceType2,
  ue-PositioningMeasQuality UE-PositioningMeasQuality,
  roundTripTime RoundTripTime,
  iE-Extensions ProtocolExtensionContainer { { RoundTripTimeInfo-ExtIEs } }
  OPTIONAL,
  ...
}

RoundTripTimeInfo-ExtIEs PCAP-PROTOCOL-EXTENSION ::= {
  ...
}

UE-RxTxTimeDifferenceType2 ::= INTEGER (0..8191)

UE-PositioningMeasQuality ::= SEQUENCE {
  stdResolution BIT STRING (SIZE (2)),
  numberOfMeasurements BIT STRING (SIZE (3)),
  stdOfMeasurements BIT STRING (SIZE (5)),
  iE-Extensions ProtocolExtensionContainer { { UE-PositioningMeasQuality-
ExtIEs } } OPTIONAL,
  ...
}

UE-PositioningMeasQuality-ExtIEs PCAP-PROTOCOL-EXTENSION ::= {
  ...
}

RoundTripTime ::= INTEGER (0..32766)
-- Actual value RoundTripTime = IE value * 0.0625 + 876

UTRANAccessPointPositionAltitude ::= SEQUENCE {
  geographicalCoordinates GeographicalCoordinates,
  ga-AltitudeAndDirection GA-AltitudeAndDirection
  OPTIONAL,
  iE-Extensions ProtocolExtensionContainer { {
UTRANAccessPointPositionAltitude-ExtIEs } } OPTIONAL,
  ...
}

UTRANAccessPointPositionAltitude-ExtIEs PCAP-PROTOCOL-EXTENSION ::= {
  ...
}

RxTimingDeviationInfo ::= SEQUENCE {
  rxTimingDeviation RxTimingDeviation,
  timingAdvance TimingAdvance,
  iE-Extensions ProtocolExtensionContainer { { RxTimingDeviationInfo-ExtIEs
} } OPTIONAL,
  ...
}

RxTimingDeviationInfo-ExtIEs PCAP-PROTOCOL-EXTENSION ::= {
  ...
}

RxTimingDeviationLCRInfo ::= SEQUENCE {

```

```

        rxTimingDeviationLCR                RxTimingDeviationLCR,
        timingAdvanceLCR                    TimingAdvanceLCR,
        iE-Extensions                        ProtocolExtensionContainer { { RxTimingDeviationLCRInfo-
ExtIEs } } OPTIONAL,
        ...
    }

RxTimingDeviationLCRInfo-ExtIEs PCAP-PROTOCOL-EXTENSION ::= {
    ...
}

RxTimingDeviation ::= INTEGER (0..8191)

RxTimingDeviationLCR ::= INTEGER (0..511)

TimingAdvance ::= INTEGER (0..63)

TimingAdvanceLCR ::= INTEGER (0..2047)

Pathloss ::= INTEGER (46..158)
-- Unit: dB; as defined in [4] subclause 10.3.7.3

-- *****
--
-- Client Type
--
-- *****

ClientType ::= ENUMERATED {
    emergency-services,
    value-added-services,
    plmn-operator-services,
    lawful-intercept-services,
    plmn-operator-broadcast-services,
    plmn-operator-oam,
    plmn-operator-anonymous-statistics,
    plmn-operator-target-ms-service-support,
    ...
}

-- *****
--
-- CriticalityDiagnostics
--
-- *****

CriticalityDiagnostics ::= SEQUENCE {
    procedureCode                ProcedureCode
    OPTIONAL,
    triggeringMessage              TriggeringMessage
    OPTIONAL,
    procedureCriticality           Criticality
    OPTIONAL,
    transactionID                 TransactionID
    OPTIONAL,
    iEsCriticalityDiagnostics     CriticalityDiagnostics-IE-List OPTIONAL,
    iE-Extensions                 ProtocolExtensionContainer { {CriticalityDiagnostics-ExtIEs} }
    OPTIONAL,
    ...
}

CriticalityDiagnostics-IE-List ::= SEQUENCE (SIZE (1..maxNrOfErrors)) OF
SEQUENCE {
    iECriticality                 Criticality,
    iE-ID                         ProtocolIE-ID,
    repetitionNumber              CriticalityDiagnosticsRepetition
    OPTIONAL,
    messageStructure              MessageStructure
    OPTIONAL,
    typeOfError                   TypeOfError,
    iE-Extensions                 ProtocolExtensionContainer { {CriticalityDiagnostics-IE-List-ExtIEs}
} OPTIONAL,
    ...
}

CriticalityDiagnostics-IE-List-ExtIEs PCAP-PROTOCOL-EXTENSION ::= {
    ...
}

```

```

CriticalityDiagnostics-ExtIEs PCAP-PROTOCOL-EXTENSION ::= {
  ...
}

CriticalityDiagnosticsRepetition ::= INTEGER (0..255)

TypeOfError ::= ENUMERATED {
  not-understood,
  missing,
  ...
}

-- *****
--
-- DGPSCorrections
--
-- *****

DGPSCorrections ::=
    SEQUENCE {
        gps-TOW-sec                INTEGER (0..604799),
        statusHealth                DiffCorrectionStatus,
        dgps-CorrectionSatInfoList  DGPS-CorrectionSatInfoList
        OPTIONAL,
        -- not included if satelliteHealth is equal to noData or invalidData
        iE-Extensions                ProtocolExtensionContainer { { DGPSCorrections-ExtIEs } }
        OPTIONAL,
        ...
    }

DGPSCorrections-ExtIEs PCAP-PROTOCOL-EXTENSION ::= {
  ...
}

DiffCorrectionStatus ::=
    ENUMERATED {
        udre-1-0, udre-0-75, udre-0-5, udre-0-3,
        udre-0-2, udre-0-1, noData, invalidData }

DGPS-CorrectionSatInfoList ::=
    SEQUENCE (SIZE (1..maxSat)) OF
        DGPS-CorrectionSatInfo

DGPS-CorrectionSatInfo ::=
    SEQUENCE {
        satID                INTEGER (0..63),
        iode                  INTEGER (0..255),
        udre                  UDRE,
        prc                   PRC,
        rrc                   RRC,
        iE-Extensions        ProtocolExtensionContainer { { DGPS-CorrectionSatInfo-ExtIEs } }
        OPTIONAL,
        ...
    }

DGPS-CorrectionSatInfo-ExtIEs PCAP-PROTOCOL-EXTENSION ::= {
  ...
}

UDRE ::=
    ENUMERATED {
        lessThan1,
        between1-and-4,
        between4-and-8,
        over8 }

PRC ::=
    INTEGER (-2047..2047)

RRC ::=
    INTEGER (-127..127)

-- *****
--
-- UE-PositionEstimate (i.e., Geographical Area)

```

```

--
-- *****
-- UE-PositionEstimate is based on Geographical Area Description in 23.032

UE-PositionEstimate ::= CHOICE {
    point                GA-Point,
    pointWithUncertainty    GA-PointWithUncertainty,
    polygon                GA-Polygon,
    pointWithUncertaintyEllipse    GA-PointWithUncertaintyEllipse,
    pointWithAltitude        GA-PointWithAltitude,
    pointWithAltitudeAndUncertaintyEllipsoid    GA-PointWithAltitudeAndUncertaintyEllipsoid,
    ellipsoidArc            GA-EllipsoidArc,
    ...
}

GeographicalCoordinates ::= SEQUENCE {
    latitudeSign          ENUMERATED {north, south},
    latitude              INTEGER (0..8388607),
    longitude             INTEGER (-8388608..8388607),
    iE-Extensions        ProtocolExtensionContainer { {GeographicalCoordinates-ExtIEs} }
OPTIONAL,
    ...
}

GeographicalCoordinates-ExtIEs PCAP-PROTOCOL-EXTENSION ::= {
    ...
}

GA-AltitudeAndDirection ::= SEQUENCE {
    directionOfAltitude  ENUMERATED {height, depth},
    altitude              INTEGER (0..32767),
    ...
}

GA-EllipsoidArc ::= SEQUENCE {
    geographicalCoordinates    GeographicalCoordinates,
    innerRadius                INTEGER (0..65535),
    uncertaintyRadius          INTEGER (0..127),
    offsetAngle                INTEGER (0..179),
    includedAngle              INTEGER (0..179),
    confidence                  INTEGER (0..100),
    iE-Extensions              ProtocolExtensionContainer { { GA-EllipsoidArc-ExtIEs} } OPTIONAL,
    ...
}

GA-EllipsoidArc-ExtIEs PCAP-PROTOCOL-EXTENSION ::= {
    ...
}

GA-Point ::= SEQUENCE {
    geographicalCoordinates    GeographicalCoordinates,
    iE-Extensions              ProtocolExtensionContainer { {GA-Point-ExtIEs} } OPTIONAL,
    ...
}

GA-Point-ExtIEs PCAP-PROTOCOL-EXTENSION ::= {
    ...
}

GA-PointWithAltitude ::= SEQUENCE {
    geographicalCoordinates    GeographicalCoordinates,
    altitudeAndDirection      GA-AltitudeAndDirection,
    iE-Extensions              ProtocolExtensionContainer { { GA-PointWithAltitude-ExtIEs} }
OPTIONAL,
    ...
}

GA-PointWithAltitude-ExtIEs PCAP-PROTOCOL-EXTENSION ::= {
    ...
}

GA-PointWithAltitudeAndUncertaintyEllipsoid ::= SEQUENCE {
    geographicalCoordinates    GeographicalCoordinates,
    altitudeAndDirection      GA-AltitudeAndDirection,
    uncertaintyEllipse         GA-UncertaintyEllipse,
    uncertaintyAltitude        INTEGER (0..127),
    confidence                  INTEGER (0..100),
}

```



```

    iE-Extensions          ProtocolExtensionContainer { { GA-
PointWithAltitudeAndUncertaintyEllipsoid-ExtIEs } } OPTIONAL,
    ...
}

GA-PointWithAltitudeAndUncertaintyEllipsoid-ExtIEs PCAP-PROTOCOL-EXTENSION ::= {
    ...
}

GA-PointWithUnCertainty ::= SEQUENCE {
    geographicalCoordinates    GeographicalCoordinates,
    uncertaintyCode            INTEGER (0..127),
    iE-Extensions              ProtocolExtensionContainer { {GA-PointWithUnCertainty-ExtIEs } }
OPTIONAL,
    ...}

GA-PointWithUnCertainty-ExtIEs PCAP-PROTOCOL-EXTENSION ::= {
    ...
}

GA-PointWithUnCertaintyEllipse ::= SEQUENCE {
    geographicalCoordinates    GeographicalCoordinates,
    uncertaintyEllipse         GA-UncertaintyEllipse,
    confidence                  INTEGER (0..100),
    iE-Extensions              ProtocolExtensionContainer { { GA-PointWithUnCertaintyEllipse-
ExtIEs } } OPTIONAL,
    ...
}

GA-PointWithUnCertaintyEllipse-ExtIEs PCAP-PROTOCOL-EXTENSION ::= {
    ...
}

GA-Polygon ::= SEQUENCE (SIZE (1..maxNrOfPoints)) OF
    SEQUENCE {
        geographicalCoordinates    GeographicalCoordinates,
        iE-Extensions              ProtocolExtensionContainer { {GA-Polygon-ExtIEs} } OPTIONAL,
        ...
    }

GA-Polygon-ExtIEs PCAP-PROTOCOL-EXTENSION ::= {
    ...
}

GA-UncertaintyEllipse ::= SEQUENCE {
    uncertaintySemi-major        INTEGER (0..127),
    uncertaintySemi-minor        INTEGER (0..127),
    orientationOfMajorAxis       INTEGER (0..89),
    ...
}

-- *****
--
-- Position Data
--
-- *****

PositionData ::= SEQUENCE {
    positioningDataDiscriminator    PositioningDataDiscriminator,
    positioningDataSet               PositioningDataSet                OPTIONAL,
-- This IE shall be present if the PositioningDataDiscriminator IE is set to the value "0000" --
    iE-Extensions                    ProtocolExtensionContainer { {PositionData-ExtIEs} } OPTIONAL,
    ...
}

PositionData-ExtIEs PCAP-PROTOCOL-EXTENSION ::= {
    ...
}

PositioningDataDiscriminator ::= BIT STRING (SIZE(4))

PositioningDataSet ::= SEQUENCE(SIZE(1..maxSet)) OF PositioningMethodAndUsage

PositioningMethodAndUsage ::= OCTET STRING (SIZE(1))

-- *****
--
-- GPS-AcquisitionAssistance:

```

```

--
-- *****

GPS-AcquisitionAssistance ::= SEQUENCE {
    gps-TOW-lmsec                INTEGER (0..604799999),
    satelliteInformationList     AcquisitionSatInfoList,
    iE-Extensions                ProtocolExtensionContainer { { GPS-AcquisitionAssistance-
ExtIEs } } OPTIONAL,
    ...
}

GPS-AcquisitionAssistance-ExtIEs PCAP-PROTOCOL-EXTENSION ::= {
    ...
}

AcquisitionSatInfoList ::= SEQUENCE (SIZE (1..maxSat)) OF
    AcquisitionSatInfo

AcquisitionSatInfo ::= SEQUENCE {
    satID                        INTEGER (0..63),
    doppler0thOrder              INTEGER (-2048..2047),
    extraDopplerInfo             ExtraDopplerInfo
    OPTIONAL,
    codePhase                    INTEGER (0..1022),
    integerCodePhase             INTEGER (0..19),
    gps-BitNumber                INTEGER (0..3),
    codePhaseSearchWindow        CodePhaseSearchWindow,
    azimuthAndElevation          AzimuthAndElevation
    OPTIONAL,
    iE-Extensions                ProtocolExtensionContainer { { AcquisitionSatInfo-ExtIEs } }
    OPTIONAL,
    ...
}

AcquisitionSatInfo-ExtIEs PCAP-PROTOCOL-EXTENSION ::= {
    ...
}

ExtraDopplerInfo ::= SEQUENCE {
    doppler1stOrder              INTEGER (-42..21),
    dopplerUncertainty           DopplerUncertainty,
    iE-Extensions                ProtocolExtensionContainer { { ExtraDopplerInfo-ExtIEs } }
    OPTIONAL,
    ...
}

ExtraDopplerInfo-ExtIEs PCAP-PROTOCOL-EXTENSION ::= {
    ...
}

DopplerUncertainty ::= ENUMERATED {
    hz12-5, hz25, hz50, hz100, hz200, ...}

CodePhaseSearchWindow ::= ENUMERATED {
    w1023, w1, w2, w3, w4, w6, w8,
    w12, w16, w24, w32, w48, w64,
    w96, w128, w192 }

AzimuthAndElevation ::= SEQUENCE {
    azimuth                      INTEGER (0..31),
    elevation                    INTEGER (0..7),
    iE-Extensions                ProtocolExtensionContainer { { AzimuthAndElevation-ExtIEs } }
    OPTIONAL,
    ...
}

AzimuthAndElevation-ExtIEs PCAP-PROTOCOL-EXTENSION ::= {
    ...
}

-- *****

```

```

--
-- GPS Almanac and Satellite Health
--
-- *****

GPS-AlmanacAndSatelliteHealth ::= SEQUENCE {
    wn-a                BIT STRING (SIZE (8)),
    almanacSatInfoList AlmanacSatInfoList,
    svGlobalHealth     BIT STRING (SIZE (364)) OPTIONAL,
    iE-Extensions      ProtocolExtensionContainer { { GPS-
AlmanacAndSatelliteHealth-ExtIEs } }
    OPTIONAL,
    ...
}

GPS-AlmanacAndSatelliteHealth-ExtIEs PCAP-PROTOCOL-EXTENSION ::= {
    ...
}

AlmanacSatInfoList ::= SEQUENCE (SIZE (1..maxSatAlmanac)) OF
    AlmanacSatInfo

AlmanacSatInfo ::= SEQUENCE {
    dataID             BIT STRING (SIZE (2)),
    satID              INTEGER (0..63),
    e                  BIT STRING (SIZE (16)),
    t-oa               BIT STRING (SIZE (8)),
    deltaI             BIT STRING (SIZE (16)),
    omegaDot           BIT STRING (SIZE (16)),
    satHealth          BIT STRING (SIZE (8)),
    a-Sqrt             BIT STRING (SIZE (24)),
    omega0             BIT STRING (SIZE (24)),
    m0                 BIT STRING (SIZE (24)),
    omega              BIT STRING (SIZE (24)),
    af0                BIT STRING (SIZE (11)),
    af1                BIT STRING (SIZE (11)),
    iE-Extensions     ProtocolExtensionContainer { { AlmanacSatInfo-ExtIEs } }
    OPTIONAL,
    ...
}

AlmanacSatInfo-ExtIEs PCAP-PROTOCOL-EXTENSION ::= {
    ...
}

-- *****
--
-- GPS Clock And Ephemeris Parameters
--
-- *****

GPS-ClockAndEphemerisParameters ::= SEQUENCE {
    codeOnL2           BIT STRING (SIZE (2)),
    uraIndex           BIT STRING (SIZE (4)),
    satHealth          BIT STRING (SIZE (6)),
    iodc               BIT STRING (SIZE (10)),
    l2Pflag            BIT STRING (SIZE (1)),
    sflRevd            SubFrame1Reserved,
    t-GD               BIT STRING (SIZE (8)),
    t-oc               BIT STRING (SIZE (16)),
    af2                BIT STRING (SIZE (8)),
    af1                BIT STRING (SIZE (16)),
    af0                BIT STRING (SIZE (22)),
    c-rs               BIT STRING (SIZE (16)),
    delta-n            BIT STRING (SIZE (16)),
    m0                 BIT STRING (SIZE (32)),
    c-uc               BIT STRING (SIZE (16)),
    e                  BIT STRING (SIZE (32)),
    c-us               BIT STRING (SIZE (16)),
    a-Sqrt             BIT STRING (SIZE (32)),
    t-oe               BIT STRING (SIZE (16)),
    fitInterval        BIT STRING (SIZE (1)),
    aodo               BIT STRING (SIZE (5)),
    c-ic               BIT STRING (SIZE (16)),
    omega0             BIT STRING (SIZE (32)),
}

```

```

    c-is          BIT STRING (SIZE (16)),
    i0           BIT STRING (SIZE (32)),
    c-rc        BIT STRING (SIZE (16)),
    omega       BIT STRING (SIZE (32)),
    omegaDot    BIT STRING (SIZE (24)),
    iDot        BIT STRING (SIZE (14)),
    iE-Extensions ProtocolExtensionContainer { { GPS-
ClockAndEphemerisParameters-ExtIEs } } OPTIONAL,
    ...
}

GPS-ClockAndEphemerisParameters-ExtIEs PCAP-PROTOCOL-EXTENSION ::= {
    ...
}

SubFrame1Reserved ::= SEQUENCE {
    reserved1 BIT STRING (SIZE (23)),
    reserved2 BIT STRING (SIZE (24)),
    reserved3 BIT STRING (SIZE (24)),
    reserved4 BIT STRING (SIZE (16))
}

-- *****
--
-- GPS Ionospheric Model
--
-- *****

GPS-Ionospheric-Model ::= SEQUENCE {
    alfa0 BIT STRING (SIZE (8)),
    alfa1 BIT STRING (SIZE (8)),
    alfa2 BIT STRING (SIZE (8)),
    alfa3 BIT STRING (SIZE (8)),
    beta0 BIT STRING (SIZE (8)),
    beta1 BIT STRING (SIZE (8)),
    beta2 BIT STRING (SIZE (8)),
    beta3 BIT STRING (SIZE (8)),
    iE-Extensions ProtocolExtensionContainer { { GPS-Ionospheric-Model-ExtIEs
} } OPTIONAL,
    ...
}

GPS-Ionospheric-Model-ExtIEs PCAP-PROTOCOL-EXTENSION ::= {
    ...
}

-- *****
--
-- GPS Measured Results
--
-- *****

MeasuredResultsList ::= SEQUENCE (SIZE (0..maxNrOfSets)) OF
    GPS-MeasuredResults

GPS-MeasuredResults ::= SEQUENCE {
    gps-TOW-lmsec INTEGER (0..604799999),
    gps-MeasurementParamList GPS-MeasurementParamList,
    iE-Extensions ProtocolExtensionContainer { { GPS-MeasuredResults-ExtIEs }
} OPTIONAL,
    ...
}

GPS-MeasuredResults-ExtIEs PCAP-PROTOCOL-EXTENSION ::= {
    ...
}

GPS-MeasurementParamList ::= SEQUENCE (SIZE (1..maxSat)) OF
    GPS-MeasurementParam

GPS-MeasurementParam ::= SEQUENCE {
    satelliteID INTEGER (0..63),
    c-N0 INTEGER (0..63),

```

```

    doppler                INTEGER (-32768..32768),
    wholeGPS-Chips         INTEGER (0..1022),
    fractionalGPS-Chips    INTEGER (0..1023),
    multipathIndicator     MultipathIndicator,
    pseudorangeRMS-Error  INTEGER (0..63),
    iE-Extensions         ProtocolExtensionContainer { { GPS-MeasurementParam-ExtIEs }
  } OPTIONAL,
  ...
}

MultipathIndicator ::=          ENUMERATED {
                                nm,
                                low,
                                medium,
                                high }

GPS-MeasurementParam-ExtIEs PCAP-PROTOCOL-EXTENSION ::= {
  ...
}

-- *****
--
-- GPS Navigation Model
--
-- *****

GPS-NavigationModel ::=      SEQUENCE (SIZE (1..maxSat)) OF
                              NavigationModelSatInfo

NavigationModelSatInfo ::=   SEQUENCE {
    satID                    INTEGER (0..63),
    satelliteStatus          SatelliteStatus,
    gps-clockAndEphemerisParms GPS-ClockAndEphemerisParameters
    OPTIONAL,
    -- This IE is not present if satelliteStatus is es-SN
    iE-Extensions           ProtocolExtensionContainer { { NavigationModelSatInfo-ExtIEs
  } } OPTIONAL,
  ...
}

NavigationModelSatInfo-ExtIEs PCAP-PROTOCOL-EXTENSION ::= {
  ...
}

SatelliteStatus ::=         ENUMERATED {
                                ns-NN,
                                es-SN,
                                es-NN,
                                rev2,
                                rev }

-- *****
--
-- GPS Real Time Integrity
--
-- *****

GPS-RealTimeIntegrity ::= CHOICE {
    badSatellites           BadSatList,
    noBadSatellites        NoBadSatellites,
    ...
}

BadSatList ::=              SEQUENCE (SIZE (1..maxSat)) OF
                              INTEGER (0..63)

NoBadSatellites ::= NULL

-- *****
--
-- GPS Reference Time

```

```

--
-- *****
GPS-ReferenceTime ::=
    SEQUENCE {
        gps-Week          INTEGER (0..1023),
        gps-TOW-1msec     INTEGER (0..604799999),
        gps-TOW-AssistList GPS-TOW-AssistList
        OPTIONAL,
        iE-Extensions     ProtocolExtensionContainer { { GPS-ReferenceTime-ExtIEs } }
        OPTIONAL,
        ...
    }

GPS-ReferenceTime-ExtIEs PCAP-PROTOCOL-EXTENSION ::= {
    ...
}

GPS-TOW-AssistList ::=
    SEQUENCE (SIZE (1..maxSat)) OF
        GPS-TOW-Assist

GPS-TOW-Assist ::=
    SEQUENCE {
        satID            INTEGER (0..63),
        tlm-Message      BIT STRING (SIZE (14)),
        antiSpoof        BOOLEAN,
        alert            BOOLEAN,
        tlm-Reserved     BIT STRING (SIZE (2)),
        iE-Extensions     ProtocolExtensionContainer { { GPS-TOW-Assist-ExtIEs } }
        OPTIONAL,
        ...
    }

GPS-TOW-Assist-ExtIEs PCAP-PROTOCOL-EXTENSION ::= {
    ...
}

-- *****
--
-- GPS Transmission TOW
--
-- *****

GPS-Transmission-TOW ::= INTEGER (0..604799)

-- *****
--
-- GPS UTC Model
--
-- *****

GPS-UTC-Model ::=
    SEQUENCE {
        al              BIT STRING (SIZE (24)),
        a0              BIT STRING (SIZE (32)),
        t-ot            BIT STRING (SIZE (8)),
        delta-t-LS     BIT STRING (SIZE (8)),
        wn-t           BIT STRING (SIZE (8)),
        wn-lsf         BIT STRING (SIZE (8)),
        dn             BIT STRING (SIZE (8)),
        delta-t-LSF    BIT STRING (SIZE (8)),
        iE-Extensions     ProtocolExtensionContainer { { GPS-UTCmodel-ExtIEs } }
        OPTIONAL,
        ...
    }

GPS-UTCmodel-ExtIEs PCAP-PROTOCOL-EXTENSION ::= {
    ...
}

-- *****
--
-- GPS UTRAN Time Relationship Uncertainty
-- nsec=nanosecond, usec=microsecond, msec=millisecond, sec=second
--

```

```

-- *****
GPS-UTRAN-TRU ::= ENUMERATED {
    nsec-50,
    nsec-500,
    usec-1,
    usec-10,
    msec-1,
    msec-10,
    msec-100,
    unreliable,
    ...}

-- *****
--
-- Information Exchange ID
--
-- *****

InformationExchangeID ::= INTEGER (0..1048575)

-- *****
--
-- Information Report Characteristics
--
-- *****

InformationReportCharacteristics ::= SEQUENCE {
    type                InformationReportCharacteristicsType,
    periodicity         InformationReportPeriodicity    OPTIONAL,
    -- present if type indicates periodic
    ...
}

InformationReportCharacteristicsType ::= ENUMERATED {
    onDemand,
    periodic,
    onModification,
    ...
}

InformationReportPeriodicity ::= CHOICE {
    min                INTEGER (1..60, ...),
    -- Unit min, Step lmin
    hour               INTEGER (1..24, ...),
    -- Unit hour, Step lhour
    ...
}

-- *****
--
-- Information Type
--
-- *****

InformationType ::= CHOICE {
    implicitInformation    MethodType,
    explicitInformation    ExplicitInformationList,
    ...
}

ExplicitInformationList ::= SEQUENCE (SIZE (1..maxNrOfExpInfo)) OF ExplicitInformation

ExplicitInformation ::= CHOICE {
    almanacAndSatelliteHealth    AlmanacAndSatelliteHealth,
    utcModel                     UtcModel,
    ionosphericModel             IonosphericModel,
    navigationModel              NavigationModel,
    dgpsCorrections              DgpsCorrections,
    referenceTime                ReferenceTime,
    acquisitionAssistance        AcquisitionAssistance,
    realTimeIntegrity            RealTimeIntegrity,
    almanacAndSatelliteHealthSIB    AlmanacAndSatelliteHealthSIB-InfoType,
}

```

```

    ...
}

AlmanacAndSatelliteHealth ::= NULL

UtcModel ::= SEQUENCE {
    transmissionTOWIndicator    TransmissionTOWIndicator,
    iE-Extensions              ProtocolExtensionContainer { { UtcModel-ExtIEs } } OPTIONAL,
    ...
}

UtcModel-ExtIEs PCAP-PROTOCOL-EXTENSION ::= {
    ...
}

IonosphericModel ::= SEQUENCE {
    transmissionTOWIndicator    TransmissionTOWIndicator,
    iE-Extensions              ProtocolExtensionContainer { { IonosphericModel-ExtIEs } } OPTIONAL,
    ...
}

IonosphericModel-ExtIEs PCAP-PROTOCOL-EXTENSION ::= {
    ...
}

NavigationModel ::= SEQUENCE {
    transmissionTOWIndicator    TransmissionTOWIndicator,
    navModelAdditionalData      NavModelAdditionalData OPTIONAL,
    iE-Extensions              ProtocolExtensionContainer { { NavigationModel-ExtIEs } }
    OPTIONAL,
    ...
}

NavigationModel-ExtIEs PCAP-PROTOCOL-EXTENSION ::= {
    ...
}

NavModelAdditionalData ::= SEQUENCE {
    gps-Week                   INTEGER (0..1023),
    gps-TOE                     INTEGER (0..167),
    t-TOE-limit                 INTEGER (0..10),
    satRelatedDataList          SatelliteRelatedDataList,
    iE-Extensions              ProtocolExtensionContainer { { NavModelAdditionalData-ExtIEs } }
    OPTIONAL,
    ...
}

NavModelAdditionalData-ExtIEs PCAP-PROTOCOL-EXTENSION ::= {
    ...
}

SatelliteRelatedDataList ::= SEQUENCE (SIZE (0..maxSat)) OF SatelliteRelatedData

SatelliteRelatedData ::= SEQUENCE {
    satID                       INTEGER (0..63),
    iode                         INTEGER (0..255),
    iE-Extensions              ProtocolExtensionContainer { { SatelliteRelatedData-ExtIEs } }
    OPTIONAL,
    ...
}

SatelliteRelatedData-ExtIEs PCAP-PROTOCOL-EXTENSION ::= {
    ...
}

DgpsCorrections ::= NULL

ReferenceTime ::= NULL

AcquisitionAssistance ::= NULL

RealTimeIntegrity ::= NULL

AlmanacAndSatelliteHealthSIB-InfoType ::= SEQUENCE {
    transmissionTOWIndicator    TransmissionTOWIndicator,
    iE-Extensions              ProtocolExtensionContainer { { AlmanacAndSatelliteHealthSIB-
    InfoType-ExtIEs } } OPTIONAL,

```



```

    ...
}

AlmanacAndSatelliteHealthSIB-InfoType-ExtIEs PCAP-PROTOCOL-EXTENSION ::= {
    ...
}

TransmissionTOWIndicator ::= ENUMERATED {
    requested,
    not-Requested
}

-- *****
--
-- Message Structure
--
-- *****

MessageStructure ::= SEQUENCE (SIZE (1..maxNrOfLevels)) OF
    SEQUENCE {
        iE-ID                ProtocolIE-ID,
        repetitionNumber     MessageStructureRepetition
    OPTIONAL,
        iE-Extensions        ProtocolExtensionContainer { {MessageStructure-ExtIEs} }
    OPTIONAL,
        ...
    }

MessageStructureRepetition ::= INTEGER (1..256)

MessageStructure-ExtIEs PCAP-PROTOCOL-EXTENSION ::= {
    ...
}

-- *****
--
-- Method Type
--
-- *****

MethodType ::= ENUMERATED {
    ue-assisted,
    ue-based
}

-- *****
--
-- OTDOA Measurement Group
--
-- *****

OTDOA-MeasurementGroup ::=
    SEQUENCE {
        otdoa-ReferenceCellInfo     OTDOA-ReferenceCellInfo,
        otdoa-NeighbourCellInfoList OTDOA-NeighbourCellInfoList,
        otdoa-MeasuredResultsSets   OTDOA-MeasuredResultsSets,
        iE-Extensions                ProtocolExtensionContainer { { OTDOA-MeasurementGroup-ExtIEs
    } }
    OPTIONAL,
    ...
}

OTDOA-MeasurementGroup-ExtIEs PCAP-PROTOCOL-EXTENSION ::= {
    ...
}

OTDOA-ReferenceCellInfo ::=
    SEQUENCE {
        uC-ID                UC-ID,
        uTRANAccessPointPositionAltitude UTRANAccessPointPositionAltitude,
        tUTRANGPSMeasurementValueInfo   TUTRANGPSMeasurementValueInfo
    OPTIONAL,
        iE-Extensions        ProtocolExtensionContainer { { OTDOA-ReferenceCellInfo-
ExtIEs } }
    OPTIONAL,
    ...
}

OTDOA-ReferenceCellInfo-ExtIEs PCAP-PROTOCOL-EXTENSION ::= {

```

```

}
...
}
OTDOA-NeighbourCellInfoList ::= SEQUENCE (SIZE (1..maxNrOfMeasNCell)) OF
  OTDOA-NeighbourCellInfo
OTDOA-NeighbourCellInfo ::= SEQUENCE {
  uC-ID UC-ID,
  uTRANAccessPointPositionAltitude UTRANAccessPointPositionAltitude,
  relativeTimingDifferenceInfo RelativeTimingDifferenceInfo,
  iE-Extensions ProtocolExtensionContainer { { OTDOA-NeighbourCellInfo-
ExtIEs } } OPTIONAL,
  ...
}
OTDOA-NeighbourCellInfo-ExtIEs PCAP-PROTOCOL-EXTENSION ::= {
  ...
}
OTDOA-MeasuredResultsSets ::= SEQUENCE (SIZE (1..maxNrOfMeasurements)) OF
  OTDOA-MeasuredResultsInfoList
OTDOA-MeasuredResultsInfoList ::= SEQUENCE (SIZE (1..maxNrOfMeasNCell)) OF
  OTDOA-MeasuredResultsInfo
OTDOA-MeasuredResultsInfo ::= SEQUENCE {
  uC-ID UC-ID,
  ue-SFNSFNTimeDifferenceType2Info UE-SFNSFNTimeDifferenceType2Info,
  iE-Extensions ProtocolExtensionContainer { { OTDOA-MeasuredResultsInfo-
ExtIEs } } OPTIONAL,
  ...
}
OTDOA-MeasuredResultsInfo-ExtIEs PCAP-PROTOCOL-EXTENSION ::= {
  ...
}
UE-SFNSFNTimeDifferenceType2Info ::= SEQUENCE {
  ue-SFNSFNTimeDifferenceType2 INTEGER (0..40961),
  ue-PositioningMeasQuality UE-PositioningMeasQuality,
  measurementDelay INTEGER (0..65535),
  iE-Extensions ProtocolExtensionContainer { { UE-SFNSFNTimeDifferenceInfo-
ExtIEs } } OPTIONAL,
  ...
}
UE-SFNSFNTimeDifferenceInfo-ExtIEs PCAP-PROTOCOL-EXTENSION ::= {
  ...
}
UC-ID ::= SEQUENCE {
  rNC-ID INTEGER (0..4095),
  c-ID INTEGER (0..65535),
  iE-Extensions ProtocolExtensionContainer { { UC-ID-ExtIEs } }
  OPTIONAL,
  ...
}
UC-ID-ExtIEs PCAP-PROTOCOL-EXTENSION ::= {
  ...
}
RelativeTimingDifferenceInfo ::= CHOICE {
  sFNSFNMeasurementValueInfo SFNSFNMeasurementValueInfo,
  tUTRANGPSMeasurementValueInfo TUTRANGPSMeasurementValueInfo,
  ...
}
SFNSFNMeasurementValueInfo ::= SEQUENCE {
  sFNSFNValue SFNSFNValue,
  sFNSFNQuality SFNSFNQuality
  OPTIONAL,
  sFNSFNDriftRate SFNSFNDriftRate,
  sFNSFNDriftRateQuality SFNSFNDriftRateQuality
  OPTIONAL,
  iE-Extensions ProtocolExtensionContainer { { SFNSFNMeasurementValueInfo-
ExtIEs } } OPTIONAL,
  ...
}

```

```

}

SFNSFNMeasurementValueInfo-ExtIEs PCAP-PROTOCOL-EXTENSION ::= {
    ...
}

SFNSFNValue ::=
    INTEGER (0..614399)

SFNSFNQuality ::=
    INTEGER (0..255)
-- Unit chip, Step 1/16 chip, Range 0.. 255/16 chip

SFNSFNDriftRate ::=
    INTEGER (-100..100)
-- Unit chip/s, Step 1/256 chip/s, Range -100/256..+100/256 chip/s

SFNSFNDriftRateQuality ::=
    INTEGER (0..100)
-- Unit chip/s, Step 1/256 chip/s, Range 0..100/256 chip/s

TUTRANGPSMeasurementValueInfo ::= SEQUENCE {
    sFN SFN,
    tUTRANGPS TUTRANGPS,
    tUTRANGPSQuality TUTRANGPSQuality
        OPTIONAL,
    tUTRANGPSDriftRate TUTRANGPSDriftRate,
    tUTRANGPSDriftRateQuality TUTRANGPSDriftRateQuality
        OPTIONAL,
    iE-Extensions ProtocolExtensionContainer { {
TUTRANGPSMeasurementValueInfo-ExtIEs } } OPTIONAL,
    ...
}

TUTRANGPSMeasurementValueInfo-ExtIEs PCAP-PROTOCOL-EXTENSION ::= {
    ...
}

SFN ::=
    INTEGER (0..4095)

TUTRANGPS ::=
    SEQUENCE {
        ms-part INTEGER (0..16383),
        ls-part INTEGER (0..4294967295)
    }

TUTRANGPSQuality ::=
    INTEGER (0..255)
-- Unit chip, Step 1/16 chip, Range 0.. 255/16 chip

TUTRANGPSDriftRate ::=
    INTEGER (-50..50)
-- Unit chip/s, Step 1/256 chip/s, Range -50/256..+50/256 chip/s

TUTRANGPSDriftRateQuality ::=
    INTEGER (0..50)
-- Unit chip/s, Step 1/256 chip/s, Range 0..50/256 chip/s

-- *****
--
-- Positioning Method
--
-- *****

PositioningMethod ::= SEQUENCE {
    methodType MethodType,
    selectedPositionMethod SelectedPositionMethod,
    iE-Extensions ProtocolExtensionContainer { { PositioningMethod-ExtIEs } } OPTIONAL,
    ...
}

PositioningMethod-ExtIEs PCAP-PROTOCOL-EXTENSION ::= {
    ...
}

SelectedPositionMethod ::= ENUMERATED {
    oTDOA,
    gPS,
    oTDOA-or-GPS,
    cell-id,
    uTDOA,
    ...
}

```

```

-- *****
--
-- Positioning Priority
-- *****
PositioningPriority ::= ENUMERATED {
    high-priority,
    normal-priority,
    ...
}

-- *****
--
-- Requested Data Value
-- *****

RequestedDataValue ::= SEQUENCE {
    gpsAlmanacAndSatelliteHealth      GPS-AlmanacAndSatelliteHealth
    OPTIONAL,
    gps-UTC-Model                      GPS-UTC-Model
    OPTIONAL,
    gps-Ionospheric-Model             GPS-Ionospheric-Model
    OPTIONAL,
    gps-NavigationModel               GPS-NavigationModel
    OPTIONAL,
    dgpsCorrections                   DGPSCorrections
    OPTIONAL,
    referenceTime                     GPS-ReferenceTime
    OPTIONAL,
    gps-AcquisitionAssistance         GPS-AcquisitionAssistance
    OPTIONAL,
    gps-RealTime-Integrity             GPS-RealTimeIntegrity
    OPTIONAL,
    almanacAndSatelliteHealthSIB      AlmanacAndSatelliteHealthSIB
    OPTIONAL,
    gps-Transmission-TOW              GPS-Transmission-TOW
    OPTIONAL,
    iE-Extensions                      ProtocolExtensionContainer { { RequestedDataValue-ExtIEs} }
    OPTIONAL,
    ...
}

--at least one of the above IEs shall be present in the requested data value

RequestedDataValue-ExtIEs PCAP-PROTOCOL-EXTENSION ::= {
    ...
}

-- *****
--
-- Requested Data Value Information
-- *****

RequestedDataValueInformation ::= CHOICE {
    informationAvailable               InformationAvailable,
    informationNotAvailable            InformationNotAvailable
}

InformationAvailable ::= SEQUENCE {
    requestedDataValue                RequestedDataValue,
    iE-Extensions                      ProtocolExtensionContainer { { InformationAvailable-ExtIEs} }
    OPTIONAL,
    ...
}

InformationAvailable-ExtIEs PCAP-PROTOCOL-EXTENSION ::= {
    ...
}

InformationNotAvailable ::= NULL

-- *****
--
-- Request Type

```

```

--
-- *****
RequestType ::= SEQUENCE {
    event           RequestTypeEvent,
    reportArea      RequestTypeReportArea,
    horizontalaccuracyCode RequestTypeAccuracyCode OPTIONAL,
    iE-Extensions  ProtocolExtensionContainer { { RequestType-ExtIEs} } OPTIONAL,
    ...
}

RequestType-ExtIEs PCAP-PROTOCOL-EXTENSION ::= {
    ...
}

RequestTypeEvent ::= ENUMERATED {
    stop-change-of-service-area,
    direct,
    change-of-service-area,
    stop-direct,
    ...
}

RequestTypeReportArea ::= ENUMERATED {
    service-area,
    geographical-area,
    ...
}

RequestTypeAccuracyCode ::= INTEGER (0..127)

-- *****
--
-- Response Time
--
-- *****
ResponseTime ::= ENUMERATED {
    low-delay,
    delay-tolerant,
    ...
}

-- *****
--
-- Horizontal Accuracy Code
--
-- *****

HorizontalAccuracyCode ::= INTEGER (0..127)

-- *****
--
-- UE Positioning Capability
--
-- *****
UE-PositioningCapability ::= SEQUENCE {
    standAloneLocationMethodsSupported  BOOLEAN,
    ueBasedOTDOASupported                BOOLEAN,
    networkAssistedGPSSupport            NetworkAssistedGPSSuport,
    supportGPSTimingOfCellFrame          BOOLEAN,
    supportForIPDL                        BOOLEAN,
    supportForRxTxTimeDiff                BOOLEAN,
    supportForUEAGPSinCellPCH            BOOLEAN,
    supportForSFNSFNTimeDiff             BOOLEAN,
    iE-Extensions                        ProtocolExtensionContainer { {UE-PositioningCapability-
ExtIEs} } OPTIONAL,
    ...
}

UE-PositioningCapability-ExtIEs PCAP-PROTOCOL-EXTENSION ::= {
    ...
}

NetworkAssistedGPSSuport ::= ENUMERATED {
    network-based,
    ue-based,
    both,
    none,
    ...
}

```

```

}

-- *****
--
-- UTDOA Positioning (Position Activation Request Message)
--
-- *****

UTDOAPositioning ::= SEQUENCE {
    utdoa-BitCount          UTDOA-BitCount,
    utdoa-timeInterval      UTDOA-TimeInterval,
    iE-Extensions          ProtocolExtensionContainer { { UTDOAPositioning-ExtIEs } } OPTIONAL,
    ...
}

UTDOAPositioning-ExtIEs PCAP-PROTOCOL-EXTENSION ::= {
    ...
}

UTDOA-BitCount ::= INTEGER (0..5000)

UTDOA-TimeInterval ::= INTEGER (0..3000)

EnvironmentCharacterisation ::= ENUMERATED { heavyMultipathandNLOSconditions,
    noOrLightMultipathAndUsuallyLOSconditions,
    notDefinedOrMixedEnvironment,
    ...
}

-- *****
--
-- GPS Assistance Data
--
-- *****

GPSAssistanceData ::= SEQUENCE {
    requestedDataValue      RequestedDataValue,
    tUTRANGPSMeasurementValueInfo TUTRANGPSMeasurementValueInfoGPS OPTIONAL,
    iE-Extensions          ProtocolExtensionContainer { { GPSAssistanceData-ExtIEs } }
OPTIONAL,
    ...
}

GPSAssistanceData-ExtIEs PCAP-PROTOCOL-EXTENSION ::= {
    ...
}

TUTRANGPSMeasurementValueInfoGPS ::= SEQUENCE {
    primaryScramblingCode    PrimaryScramblingCode,
    sFN                      SFN,
    tUTRANGPS                TUTRANGPS,
    tUTRANGPSQuality         TUTRANGPSQuality
OPTIONAL,
    tUTRANGPSDriftRate       TUTRANGPSDriftRate,
    tUTRANGPSDriftRateQuality TUTRANGPSDriftRateQuality
OPTIONAL,
    iE-Extensions          ProtocolExtensionContainer { {
TUTRANGPSMeasurementValueInfoGPS-ExtIEs } } OPTIONAL,
    ...
}

TUTRANGPSMeasurementValueInfoGPS-ExtIEs PCAP-PROTOCOL-EXTENSION ::= {
    ...
}

-- *****
--
-- OTDOA Assistance Data
--
-- *****

OTDOAAssistanceData ::= SEQUENCE {
    uE-Positioning-OTDOA-AssistanceData UE-Positioning-OTDOA-AssistanceData,
    iE-Extensions          ProtocolExtensionContainer { { OTDOAAssistanceData-ExtIEs } }
OPTIONAL,
    ...
}

```

```

OTDOAAssistanceData-ExtIEs PCAP-PROTOCOL-EXTENSION ::= {
  ...
}

-- *****
--
-- UE Positioning OTDOA Assistance Data
--
-- *****

UE-Positioning-OTDOA-AssistanceData ::= SEQUENCE {
  ue-positioning-OTDOA-ReferenceCellInfo      UE-Positioning-OTDOA-ReferenceCellInfo
  OPTIONAL,
  ue-positioning-OTDOA-NeighbourCellList      UE-Positioning-OTDOA-NeighbourCellList
  OPTIONAL,
  iE-Extensions                               ProtocolExtensionContainer { { UE-Positioning-
OTDOAAssistanceData-ExtIEs } } OPTIONAL,
  ...
}

UE-Positioning-OTDOAAssistanceData-ExtIEs PCAP-PROTOCOL-EXTENSION ::= {
  ...
}

UE-Positioning-OTDOA-ReferenceCellInfo ::= SEQUENCE {
  sfn                                           SFN                                           OPTIONAL,
  modeSpecificInfo CHOICE {
    fdd                                         SEQUENCE {
      primaryCPICH-Info                       PrimaryScramblingCode,
      ...
    },
    tdd                                         SEQUENCE{
      --- coding is FFS
      ...
    },
    ...
  },
  frequencyInfo                               FrequencyInfo                               OPTIONAL,
  positioningMode CHOICE {
    ueBased                                    SEQUENCE {
      cellPosition                           ReferenceCellPosition  OPTIONAL,
      -- actual value roundTripTime = (IE value * 0.0625) + 876
      roundTripTime                           INTEGER (0..32766)      OPTIONAL,
      ...
    },
    ueAssisted                                SEQUENCE {
      ...
    },
    ...
  },
  ue-positioning-IPDL-Parameters              UE-Positioning-IPDL-Parameters OPTIONAL,
  iE-Extensions                               ProtocolExtensionContainer { { UE-Positioning-
OTDOAReferenceCellInfo-ExtIEs } } OPTIONAL,
  ...
}

UE-Positioning-OTDOAReferenceCellInfo-ExtIEs PCAP-PROTOCOL-EXTENSION ::= {
  ...
}

ReferenceCellPosition ::= CHOICE {
  ellipsoidPoint                             GeographicalCoordinates,
  ellipsoidPointWithAltitude                 GA-PointWithAltitude,
  ...
}

UE-Positioning-IPDL-Parameters ::= SEQUENCE {
  modeSpecificInfo                           CHOICE {
    fdd                                       SEQUENCE {
      ip-Spacing                             IP-Spacing,
      ip-Length                              IP-Length,
      ip-Offset                              INTEGER (0..9),
      seed                                    INTEGER (0..63),
      ...
    },
    tdd                                       SEQUENCE {

```

```

        -- coding is FFS
        ...
    },
    ...
},
burstModeParameters          BurstModeParameters          OPTIONAL,
iE-Extensions                ProtocolExtensionContainer { { UE-Positioning-IPDL-
Parameters-ExtIEs } } OPTIONAL,
    ...
}

UE-Positioning-IPDL-Parameters-ExtIEs PCAP-PROTOCOL-EXTENSION ::= {
    ...
}

IP-Spacing ::=
    ENUMERATED {
        e5, e7, e10, e15, e20,
        e30, e40, e50, ... }

IP-Length ::=
    ENUMERATED {
        ip15, ip110, ... }

BurstModeParameters ::=
    SEQUENCE {
        burstStart          INTEGER (0..15),
        burstLength         INTEGER (10..25),
        burstFreq           INTEGER (1..16),
        iE-Extensions       ProtocolExtensionContainer { { BurstModeParameters-ExtIEs }
    } OPTIONAL,
    ...
}

BurstModeParameters-ExtIEs PCAP-PROTOCOL-EXTENSION ::= {
    ...
}

UE-Positioning-OTDOA-NeighbourCellList ::= SEQUENCE (SIZE (1..maxCellMeas)) OF
    UE-Positioning-OTDOA-NeighbourCellInfo

UE-Positioning-OTDOA-NeighbourCellInfo ::= SEQUENCE {
    modeSpecificInfo CHOICE {
        fdd
            primaryCPICH-Info          SEQUENCE {
                PrimaryScramblingCode,
                ...
            },
        tdd
            -- coding is FFS
            ...
    },
    ...
},
frequencyInfo          FrequencyInfo          OPTIONAL,
ue-positioning-IPDL-Parameters UE-Positioning-IPDL-Parameters OPTIONAL,
sfn-SFN-RelTimeDifference SFN-SFN-RelTimeDifference1,
sfn-Offset-Validity    SFN-Offset-Validity    OPTIONAL,
sfn-SFN-Drift          SFN-SFN-Drift          OPTIONAL,
searchWindowSize       OTDOA-SearchWindowSize,
positioningMode CHOICE {
    ueBased
        relativeNorth          INTEGER (-20000..20000)          OPTIONAL,
        relativeEast           INTEGER (-20000..20000)          OPTIONAL,
        relativeAltitude       INTEGER (-4000..4000)           OPTIONAL,
        fineSFN-SFN            FineSFNSFN                    OPTIONAL,
        -- actual value roundTripTime = (IE value * 0.0625) + 876
        roundTripTime          INTEGER (0.. 32766)              OPTIONAL,
        ...
    },
    ueAssisted              SEQUENCE {
        ...
    },
    ...
},
iE-Extensions           ProtocolExtensionContainer { { UE-Positioning-
OTDOANeighbourCellInfo-ExtIEs } } OPTIONAL,
    ...

```



```

}

UE-Positioning-OTDOANeighbourCellInfo-ExtIEs PCAP-PROTOCOL-EXTENSION ::= {
  ...
}

SFN-SFN-RelTimeDifferencel ::= SEQUENCE {
  sfn-Offset INTEGER (0 .. 4095),
  sfn-sfn-Reltimedifference INTEGER (0.. 38399),
  iE-Extensions ProtocolExtensionContainer { { SFN-SFN-RelTimeDifferencel-
ExtIEs } } OPTIONAL,
  ...
}

SFN-SFN-RelTimeDifferencel-ExtIEs PCAP-PROTOCOL-EXTENSION ::= {
  ...
}

SFN-Offset-Validity ::= ENUMERATED { false }

OTDOA-SearchWindowSize ::= ENUMERATED {
  c20, c40, c80, c160, c320,
  c640, c1280, moreThan1280, ... }

SFN-SFN-Drift ::= ENUMERATED {
  sfnsfndrift0, sfnsfndrift1, sfnsfndrift2,
  sfnsfndrift3, sfnsfndrift4, sfnsfndrift5,
  sfnsfndrift8, sfnsfndrift10, sfnsfndrift15,
  sfnsfndrift25, sfnsfndrift35, sfnsfndrift50,
  sfnsfndrift65, sfnsfndrift80, sfnsfndrift100,
  sfnsfndrift-1, sfnsfndrift-2, sfnsfndrift-3,
  sfnsfndrift-4, sfnsfndrift-5, sfnsfndrift-8,
  sfnsfndrift-10, sfnsfndrift-15, sfnsfndrift-25,
  sfnsfndrift-35, sfnsfndrift-50, sfnsfndrift-65,
  sfnsfndrift-80, sfnsfndrift-100, ...}

FineSFNSFN ::= INTEGER (0..15)
-- Range 0..0.9375 step size 0.0625

-- *****
--
-- Vertical Accuracy Code
--
-- *****

VerticalAccuracyCode ::= INTEGER (0..127)

-- *****
--
-- UTDOA Group
--
-- *****

UTDOA-Group ::= SEQUENCE {
  uC-ID UC-ID,
  frequencyInfo FrequencyInfo,
  uTDOA-ChannelSettings UTDOA-RRState,
  iE-Extensions ProtocolExtensionContainer { { UTDOA-Group-ExtIEs } }
  OPTIONAL,
  ...
}

UTDOA-Group-ExtIEs PCAP-PROTOCOL-EXTENSION ::= {
  ...
}

FrequencyInfo ::= SEQUENCE {
  modeSpecificInfo CHOICE {
    fdd FrequencyInfoFDD,
    tdd FrequencyInfoTDD,
    ...
  },

```

```

    iE-Extensions          ProtocolExtensionContainer { { FrequencyInfo-ExtIEs } }
    OPTIONAL,
    ...
}

FrequencyInfo-ExtIEs PCAP-PROTOCOL-EXTENSION ::= {
    ...
}

FrequencyInfoFDD ::=
    SEQUENCE {
        uarfcn-UL          UARFCN          OPTIONAL,
        uarfcn-DL          UARFCN,
        iE-Extensions     ProtocolExtensionContainer { { FrequencyInfoFDD-ExtIEs } }
        OPTIONAL,
        ...
    }

FrequencyInfoFDD-ExtIEs PCAP-PROTOCOL-EXTENSION ::= {
    ...
}

FrequencyInfoTDD ::=
    SEQUENCE {
        uarfcn          UARFCN,
        iE-Extensions  ProtocolExtensionContainer { {FrequencyInfoTDD-ExtIEs} }
        OPTIONAL,
        ...
    }

FrequencyInfoTDD-ExtIEs PCAP-PROTOCOL-EXTENSION ::= {
    ...
}

UTDOA-RRCState ::= CHOICE {
    uTDOA-CELLDCH  UTDOA-CELLDCH,
    uTDOA-CELLFACH UTDOA-CELLFACH,
    ...
}

-- *****
--
-- UTDOA Cell DCH Information
--
-- *****
UTDOA-CELLDCH ::= SEQUENCE {
    uL-DPCHInfo          UL-DPCHInfo,
    compressedModeAssistanceData  Compressed-Mode-Assistance-Data  OPTIONAL,
    dCH-Information     DCH-Information  OPTIONAL,
    e-DPCH-Information  E-DPCH-Information  OPTIONAL,
    iE-Extensions     ProtocolExtensionContainer { { UTDOA-CELLDCH-ExtIEs } },
    ...
}

UTDOA-CELLDCH-ExtIEs PCAP-PROTOCOL-EXTENSION ::= {
    ...
}

UL-DPCHInfo ::= CHOICE {
    fdd SEQUENCE {
        scramblingCodeType  ScramblingCodeType,
        scramblingCode      UL-ScramblingCode,
        tfci-Existence      BOOLEAN,
        numberOfFBI-Bits    NumberOfFBI-Bits,
        iE-Extensions     ProtocolExtensionContainer { { UL-DPCHInfoFDD-ExtIEs } },
        ...
    },
    tdd SEQUENCE {
        cellParameterID    CellParameterID,
        tfCI-Coding         TFCI-Coding,
        punctureLimit       PuncturingLimit,
        repetitionPeriod    RepetitionPeriod,
        repetitionLength    RepetitionLength,
        tdd-DPCHOffset      TDD-DPCHOffset,
        uL-Timeslot-Information  UL-Timeslot-Information,
        frameOffset         FrameOffset,
        specialBurstScheduling  SpecialBurstScheduling,
    }
}

```

```

        iE-Extensions      ProtocolExtensionContainer { { UL-DPCHInfoTDD-ExtIEs } },
    },
    ...
}

UL-DPCHInfoFDD-ExtIEs      PCAP-PROTOCOL-EXTENSION ::= {
    ...
}

UL-DPCHInfoTDD-ExtIEs      PCAP-PROTOCOL-EXTENSION ::= {
    ...
}

Compressed-Mode-Assistance-Data ::= SEQUENCE {
    dl-information          DL-InformationFDD,
    ul-information          UL-InformationFDD,
    iE-Extensions          ProtocolExtensionContainer { { Compressed-Mode-
Assistance-DataFDD-ExtIEs } },
    ...
}

Compressed-Mode-Assistance-DataFDD-ExtIEs      PCAP-PROTOCOL-EXTENSION ::= {
    ...
}

DL-InformationFDD ::= SEQUENCE {
    primaryScramblingCode      PrimaryScramblingCode,
    chipOffset                  ChipOffset,
    frameOffset                  FrameOffset,
    iE-Extensions          ProtocolExtensionContainer { { DL-InformationFDD-ExtIEs } },
    ...
}

DL-InformationFDD-ExtIEs      PCAP-PROTOCOL-EXTENSION ::= {
    ...
}

UL-InformationFDD ::= SEQUENCE {
    transmissionGapPatternSequenceInfo      Transmission-Gap-Pattern-Sequence-
Information,
    activePatternSequenceInfo                Active-Pattern-Sequence-Information,
    cFN                                        CFN,
    iE-Extensions          ProtocolExtensionContainer { { UL-InformationFDD-ExtIEs } },
    ...
}

UL-InformationFDD-ExtIEs      PCAP-PROTOCOL-EXTENSION ::= {
    ...
}

Transmission-Gap-Pattern-Sequence-Information ::= SEQUENCE (SIZE (1..maxTGPS)) OF
SEQUENCE {
    tGPSID          TGPSID,
    tGSN            TGSN,
    tGL1            GapLength,
    tGL2            GapLength OPTIONAL,
    tGD             TGD,
    tGPL1           GapDuration,
    uplink-Compressed-Mode-Method      Uplink-Compressed-Mode-Method,
    iE-Extensions          ProtocolExtensionContainer { {Transmission-Gap-Pattern-Sequence-
Information-ExtIEs} } OPTIONAL,
    ...
}

Transmission-Gap-Pattern-Sequence-Information-ExtIEs      PCAP-PROTOCOL-EXTENSION ::= {
    ...
}

TGD ::= INTEGER (0|15..269)
-- 0 = Undefined, only one transmission gap in the transmission gap pattern sequence

TGPRC ::= INTEGER (0..511)
-- 0 = infinity

```

```

TGPSID ::= INTEGER (1.. maxTGPS)

TGSN ::= INTEGER (0..14)

Uplink-Compressed-Mode-Method ::= ENUMERATED {
  sFdiv2,
  higher-layer-scheduling,
  ...
}

GapDuration ::= INTEGER (1..144,...)
-- Unit frame

GapLength ::= INTEGER (1..14)
-- Unit slot

Active-Pattern-Sequence-Information ::= SEQUENCE {
  cmConfigurationChangeCFN CFN,
  transmission-Gap-Pattern-Sequence-Status Transmission-Gap-Pattern-Sequence-Status-List
  OPTIONAL,
  iE-Extensions ProtocolExtensionContainer { {Active-Pattern-
Sequence-Information-ExtIEs} } OPTIONAL,
  ...
}

Active-Pattern-Sequence-Information-ExtIEs PCAP-PROTOCOL-EXTENSION ::= {
  ...
}

Transmission-Gap-Pattern-Sequence-Status-List ::= SEQUENCE (SIZE (1..maxTGPS)) OF
  SEQUENCE {
    tGPSID TGPSID,
    tGPRC TGPRC,
    tGCFN CFN,
    iE-Extensions ProtocolExtensionContainer { { Transmission-Gap-Pattern-Sequence-Status-
List-ExtIEs } } OPTIONAL,
    ...
  }

Transmission-Gap-Pattern-Sequence-Status-List-ExtIEs PCAP-PROTOCOL-EXTENSION ::= {
  ...
}

DCH-Information ::= SEQUENCE {
  tFCS TFCS,
  trChInfo TrChInfoList,
  iE-Extensions ProtocolExtensionContainer { { DCH-Information-ExtIEs } },
  ...
}

DCH-Information-ExtIEs PCAP-PROTOCOL-EXTENSION ::= {
  ...
}

TrChInfoList ::= SEQUENCE (SIZE(1..maxTrCH)) OF
  UL-TrCHInfo

UL-TrCHInfo ::= SEQUENCE {
  uL-TrCHtype UL-TrCHType,
  tfs TransportFormatSet,
  iE-Extensions ProtocolExtensionContainer { { UL-TrCHInfo-ExtIEs } },
  ...
}

UL-TrCHInfo-ExtIEs PCAP-PROTOCOL-EXTENSION ::= {
  ...
}

UL-TrCHType ::= ENUMERATED {dch, usch, ...}

E-DPCH-Information ::= SEQUENCE {
  maxSet-E-DPDCHs Max-Set-E-DPDCHs,
  ul-PunctureLimit PuncturingLimit,
  e-TFCS-Information E-TFCS-Information,
  e-TTI E-TTI,
}

```

```

    e-DPCCH-PO
    iE-Extensions
ExtIEs} } OPTIONAL,
    ...
}

E-DPCH-Information-ExtIEs PCAP-PROTOCOL-EXTENSION ::= {
    ...
}

Max-Set-E-DPDCHs ::= ENUMERATED {
    vN64, vN32, vN16, vN8, v2xN4, v2xN2, v2xN2plus2xN4,
    ...
}
-- Values related to [16]

E-TFCS-Information ::= SEQUENCE {
    e-DCH-TFCS-Index
    reference-E-TFCI-Information
    iE-Extensions
Information-ExtIEs} } OPTIONAL,
    ...
}

E-TFCS-Information-ExtIEs PCAP-PROTOCOL-EXTENSION ::= {
    ...
}

E-DCH-TFCS-Index ::= INTEGER (1..4,...)

Reference-E-TFCI-Information ::= SEQUENCE (SIZE (1..maxNrOfRefETFCIs)) OF Reference-E-TFCI-
Information-Item

Reference-E-TFCI-Information-Item ::= SEQUENCE {
    reference-E-TFCI
    reference-E-TFCI-PO
    iE-Extensions
Item-ExtIEs} } OPTIONAL,
    ...
}

Reference-E-TFCI-Information-Item-ExtIEs PCAP-PROTOCOL-EXTENSION ::= {
    ...
}

Reference-E-TFCI-PO ::= INTEGER (0.. maxNrOfRefETFCI-PO-QUANTSTEPS)
-- FFS according to mapping in [17]

E-TFCI ::= INTEGER (0..127)

E-TTI ::= ENUMERATED {
    e-TTI-2ms,
    e-TTI-10ms,
    ...
}

E-DPCCH-PO ::= INTEGER (0..maxNrOfEDPCCH-PO-QUANTSTEPS)

CellParameterID ::= INTEGER (0..127,...)

TFCI-Coding ::= ENUMERATED {
    v4,
    v8,
    v16,
    v32,
    ...
}

RepetitionLength ::= INTEGER (1..63)

RepetitionPeriod ::= ENUMERATED {
    v1,
    v2,
    v4,
    v8,
    v16,

```

```

    v32,
    v64,
    ...
}

TDD-DPCHOffset ::= CHOICE {
    initialOffset      INTEGER (0..255),
    noinitialOffset    INTEGER (0..63)
}

UL-Timeslot-Information ::= SEQUENCE (SIZE (1..maxNrOfULTSs)) OF UL-Timeslot-InformationItem

maxNrOfULTSs          INTEGER ::= 15
UL-Timeslot-InformationItem ::= SEQUENCE {
    timeSlot           TimeSlot,
    midambleShiftAndBurstType MidambleShiftAndBurstType,
    tFCI-Presence      BOOLEAN,
    uL-Code-InformationList TDD-UL-Code-Information,
    iE-Extensions      ProtocolExtensionContainer { { UL-Timeslot-
InformationItem-ExtIEs} } OPTIONAL,
    ...
}

UL-Timeslot-InformationItem-ExtIEs PCAP-PROTOCOL-EXTENSION ::= {
    ...
}

TimeSlot ::= INTEGER (0..14)

MidambleShiftAndBurstType ::= CHOICE {
    type1          SEQUENCE {
        midambleConfigurationBurstType1And3 MidambleConfigurationBurstType1And3,
        midambleAllocationMode              CHOICE {
            defaultMidamble      NULL,
            commonMidamble        NULL,
            ueSpecificMidamble    MidambleShiftLong,
            ...
        },
        ...
    },
    type2          SEQUENCE {
        midambleConfigurationBurstType2     MidambleConfigurationBurstType2,
        midambleAllocationMode              CHOICE {
            defaultMidamble      NULL,
            commonMidamble        NULL,
            ueSpecificMidamble    MidambleShiftShort,
            ...
        },
        ...
    },
    type3          SEQUENCE {
        midambleConfigurationBurstType1And3 MidambleConfigurationBurstType1And3,
        midambleAllocationMode              CHOICE {
            defaultMidamble      NULL,
            ueSpecificMidamble    MidambleShiftLong,
            ...
        },
        ...
    },
    ...
}

MidambleShiftLong ::= INTEGER (0..15)

MidambleShiftShort ::= INTEGER (0..5)

MidambleConfigurationBurstType1And3 ::= ENUMERATED {v4, v8, v16}

MidambleConfigurationBurstType2 ::= ENUMERATED {v3, v6}

TDD-UL-Code-Information ::= SEQUENCE (SIZE (1..maxNrOfDPCHs)) OF TDD-UL-Code-InformationItem

maxNrOfDPCHs          INTEGER ::= 240

TDD-UL-Code-InformationItem ::= SEQUENCE {
    tdd-ChannelisationCode TDD-ChannelisationCode,

```

```

        iE-Extensions
        InformationItem-ExtIEs} }      OPTIONAL,
    ...
}

TDD-UL-Code-InformationItem-ExtIEs PCAP-PROTOCOL-EXTENSION ::= {
    ...
}

TDD-ChannelisationCode ::= ENUMERATED {
    chCode1div1,
    chCode2div1,
    chCode2div2,
    chCode4div1,
    chCode4div2,
    chCode4div3,
    chCode4div4,
    chCode8div1,
    chCode8div2,
    chCode8div3,
    chCode8div4,
    chCode8div5,
    chCode8div6,
    chCode8div7,
    chCode8div8,
    chCode16div1,
    chCode16div2,
    chCode16div3,
    chCode16div4,
    chCode16div5,
    chCode16div6,
    chCode16div7,
    chCode16div8,
    chCode16div9,
    chCode16div10,
    chCode16div11,
    chCode16div12,
    chCode16div13,
    chCode16div14,
    chCode16div15,
    chCode16div16,
    ...
}

SpecialBurstScheduling ::= INTEGER (1..256) -- Number of frames between special burst transmission
during DTX

-- *****
--
-- UTDOA Cell Fach Information
--
-- *****

UTDOA-CELLFACH ::= SEQUENCE {
    prachParameters          PRACHparameters,
    cRNTI                    C-RNTI,
    uschParameters          UschParameters      OPTIONAL,
    iE-Extensions           ProtocolExtensionContainer { { UTDOA-CELLFACH-ExtIEs} },
    ...
}

UTDOA-CELLFACH-ExtIEs      PCAP-PROTOCOL-EXTENSION ::= {
    ...
}

PRACHparameters ::= SEQUENCE (SIZE (1..maxPRACH)) OF
    PRACH-ChannelInfo

PRACH-ChannelInfo ::= SEQUENCE {
    prach-Info              PRACH-Info,
    tFS                     TransportFormatSet,
    tFCS                    TFCS,
    iE-Extensions           ProtocolExtensionContainer { { PRACH-ChannelInfo-ExtIEs} },
    ...
}

PRACH-ChannelInfo-ExtIEs   PCAP-PROTOCOL-EXTENSION ::= {

```

```

}
...

PRACH-Info ::=
    CHOICE {
        fdd
            SEQUENCE {
                availableSignatures AvailableSignatures,
                availableSF SF-PRACH,
                preambleScramblingCodeWordNumber PreambleScramblingCodeWordNumber,
                puncturingLimit PuncturingLimit,
                availableSubChannelNumbers AvailableSubChannelNumbers,
                iE-Extensions ProtocolExtensionContainer { { PRACH-Info-FDD-ExtIEs } },
                ...
            },
        tdd
            SEQUENCE {
                timeSlot TimeSlot,
                tdd-ChannelisationCode TDD-ChannelisationCode,
                maxPRACH-MidambleShifts MaxPRACH-MidambleShifts,
                pRACH-Midamble PRACH-Midamble,
                iE-Extensions ProtocolExtensionContainer { { PRACH-Info-TDD-ExtIEs } },
                ...
            },
        ...
    }

PRACH-Info-FDD-ExtIEs PCAP-PROTOCOL-EXTENSION ::= {
    ...
}

PRACH-Info-TDD-ExtIEs PCAP-PROTOCOL-EXTENSION ::= {
    ...
}

SF-PRACH ::=
    ENUMERATED {
        sfpr32, sfpr64, sfpr128, sfpr256, ... }

AvailableSignatures ::=
    BIT STRING {
        signature15(0),
        signature14(1),
        signature13(2),
        signature12(3),
        signature11(4),
        signature10(5),
        signature9(6),
        signature8(7),
        signature7(8),
        signature6(9),
        signature5(10),
        signature4(11),
        signature3(12),
        signature2(13),
        signature1(14),
        signature0(15)
    }
    (SIZE(16))

PreambleScramblingCodeWordNumber ::= INTEGER (0..15)

PuncturingLimit ::= INTEGER (0..15)
-- 0: 40%; 1: 44%; ... 14: 96%; 15: 100%

AvailableSubChannelNumbers ::=
    BIT STRING {
        subCh11(0),
        subCh10(1),
        subCh9(2),
        subCh8(3),
        subCh7(4),
        subCh6(5),
        subCh5(6),
        subCh4(7),
        subCh3(8),
        subCh2(9),
        subCh1(10),
        subCh0(11)
    }
    (SIZE(12))

```



```

ScramblingCodeType ::=
    ENUMERATED {
        shortSC,
        longSC }

UL-ScramblingCode ::=
    INTEGER (0..16777215)

NumberOfFBI-Bits ::=
    INTEGER (0..2)

TransportFormatSet ::=
    SEQUENCE {
        dynamicPart
        semi-staticPart
        iE-Extensions
        OPTIONAL,
        ...
    }

TransportFormatSet-ExtIEs PCAP-PROTOCOL-EXTENSION ::= {
    ...
}

TransportFormatSet-DynamicPartList ::= SEQUENCE (SIZE (1..maxNrOfTFs)) OF
    SEQUENCE {
        rlc-Size
        numberOfTbsTTIList
        iE-Extensions
        DynamicPartList-ExtIEs }
        RLC-Size,
        SEQUENCE (SIZE (1..maxNrOfTFs)) OF TbsTTIInfo,
        ProtocolExtensionContainer { { TransportFormatSet-
        OPTIONAL,
        ...
    }

TransportFormatSet-DynamicPartList-ExtIEs PCAP-PROTOCOL-EXTENSION ::= {
    ...
}

TbsTTIInfo ::= SEQUENCE {
    tTIInfo
    numberOfTbs
    iE-Extensions
    ...
    TransportFormatSet-TransmissionTimeIntervalDynamic
    TransportFormatSet-NrOfTransportBlocks,
    ProtocolExtensionContainer { { TbsTTIInfo-ExtIEs } },
    OPTIONAL,
}

TbsTTIInfo-ExtIEs PCAP-PROTOCOL-EXTENSION ::= {
    ...
}

RLC-Size ::= INTEGER (129..5055)

TransportFormatSet-NrOfTransportBlocks ::= INTEGER (0..512)

TransportFormatSet-Semi-staticPart ::= SEQUENCE {
    transmissionTimeInterval
    channelCoding
    codingRate
    -- This IE shall be present if the Type of channel coding IE is set to 'convolutional' or
    'turbo'
    rateMatchingAttribute
    cRC-Size
    iE-Extensions
    staticPart-ExtIEs }
    TransportFormatSet-TransmissionTimeIntervalSemiStatic,
    TransportFormatSet-ChannelCodingType,
    TransportFormatSet-CodingRate
    OPTIONAL,
    TransportFormatSet-RateMatchingAttribute,
    TransportFormatSet-CRC-Size,
    ProtocolExtensionContainer { { TransportFormatSet-Semi-
    OPTIONAL,
    ...
}

TransportFormatSet-Semi-staticPart-ExtIEs PCAP-PROTOCOL-EXTENSION ::= {
    ...
}

TransportFormatSet-TransmissionTimeIntervalSemiStatic ::= ENUMERATED {
    msec-5,
    msec-10,
    msec-20,
    msec-40,
    msec-80,
    dynamic,
    ...
}

TransportFormatSet-ChannelCodingType ::= ENUMERATED {

```

```

    no-codingTDD,
    convolutional-coding,
    turbo-coding,
    ...
}

TransportFormatSet-CodingRate ::= ENUMERATED {
    half,
    third,
    ...
}

TransportFormatSet-RateMatchingAttribute ::= INTEGER (1..maxRateMatching)

TransportFormatSet-CRC-Size ::= ENUMERATED {
    v0,
    v8,
    v12,
    v16,
    v24,
    ...
}

TransportFormatSet-TransmissionTimeIntervalDynamic ::= ENUMERATED {
    msec-10,
    msec-20,
    msec-40,
    msec-80,
    dynamic,
    ...
}

TFCS ::= SEQUENCE (SIZE (1..maxTFC)) OF CTFC

CTFC ::= CHOICE{
    ctfc2Bit SEQUENCE (SIZE (1..maxTFC)) OF INTEGER (0..3),
    ctfc4Bit SEQUENCE (SIZE (1..maxTFC)) OF INTEGER (0..15),
    ctfc6Bit SEQUENCE (SIZE (1..maxTFC)) OF INTEGER (0..63),
    ctfc8Bit SEQUENCE (SIZE (1..maxTFC)) OF INTEGER (0..255),
    ctfc12Bit SEQUENCE (SIZE (1..maxTFC)) OF INTEGER (0..4095),
    ctfc16Bit SEQUENCE (SIZE (1..maxTFC)) OF INTEGER (0..65535),
    ctfc24Bit SEQUENCE (SIZE (1..maxTFC)) OF INTEGER (0..16777215),
    ...
}

C-RNTI ::= BIT STRING (SIZE (16))

UARFCN ::= INTEGER (0..16383)

CFN ::= INTEGER (0..255)

ChipOffset ::= INTEGER (0..38399)
-- Unit Chip

FrameOffset ::= INTEGER (0..255)

PrimaryScramblingCode ::= INTEGER (0..511)

UschParameters ::= SEQUENCE {
    cellParameterID CellParameterID,
    tFCI-Coding TFCI-Coding,
    punctureLimit PuncturingLimit,
    repetitionPeriod RepetitionPeriod,
    uSCH-SchedulingOffset USCH-SchedulingOffset,
    uL-Timeslot-Information UL-Timeslot-Information,
    tFCS TFCS,
    trChInfo TrChInfoList,
    iE-Extensions ProtocolExtensionContainer { { UschParameters-ExtIEs} },
    ...
}

UschParameters-ExtIEs PCAP-PROTOCOL-EXTENSION ::= {
    ...
}

```

```

USCH-SchedulingOffset ::= INTEGER (0..255)

MaxPRACH-MidambleShifts ::= ENUMERATED {
    shift4,
    shift8,
    ...
}

PRACH-Midamble ::= ENUMERATED {
    inverted,
    direct,
    ...
}

--*****
--
-- Positioning Response Time
--
--*****

Positioning-ResponseTime ::=
    ENUMERATED {
        ms250, ms500, s1, s2, s3, s4, s6,
        s8, s12, s16, s20, s24, s28, s32, s64,
        ...
    }

END

```

9.3.5 Common Definitions

```

-- *****
--
-- Common definitions
--
-- *****

PCAP-CommonDataTypes {
    itu-t (0) identified-organization (4) etsi (0) mobileDomain (0)
    umts-Access (20) modules (3) pcap(4) version1 (1) pcap-CommonDataTypes (3) }

DEFINITIONS AUTOMATIC TAGS ::=

BEGIN

-- *****
--
-- Extension constants
--
-- *****

maxPrivateIEs                INTEGER ::= 65535
maxProtocolExtensions        INTEGER ::= 65535
maxProtocolIEs               INTEGER ::= 65535

-- *****
--
-- Common Data Types
--
-- *****

Criticality ::= ENUMERATED { reject, ignore, notify }

Presence ::= ENUMERATED { optional, conditional, mandatory }

PrivateIE-ID ::= CHOICE {
    local          INTEGER (0..65535),
    global         OBJECT IDENTIFIER
}

ProcedureCode ::= INTEGER (0..255)

ProtocolIE-ID ::= INTEGER (0..maxProtocolIEs)

```

```

TransactionID ::= CHOICE {
    shortTID      INTEGER (0..127),
    longTID       INTEGER (0..32767)
}

TriggeringMessage ::= ENUMERATED { initiating-message, successful-outcome, unsuccessful-outcome,
outcome }

END

```

9.3.6 Constant Definitions

```

-- *****
--
-- Constant definitions
--
-- *****

PCAP-Constants {
itu-t (0) identified-organization (4) etsi (0) mobileDomain (0)
umts-Access (20) modules (3) pcap(4) version1 (1) pcap-Constants (4) }

DEFINITIONS AUTOMATIC TAGS ::=

BEGIN

IMPORTS
    ProcedureCode,
    ProtocolIE-ID
FROM PCAP-CommonDataTypes;

-- *****
--
-- Elementary Procedures
--
-- *****

id-PositionCalculation      ProcedureCode ::= 1
id-InformationExchangeInitiation ProcedureCode ::= 2
id-InformationReporting     ProcedureCode ::= 3
id-InformationExchangeTermination ProcedureCode ::= 4
id-InformationExchangeFailure ProcedureCode ::= 5
id-ErrorIndication         ProcedureCode ::= 6
id-privateMessage          ProcedureCode ::= 7
id-PositionParameterModification ProcedureCode ::= 8
id-PositionInitiation      ProcedureCode ::= 9
id-PositionActivation      ProcedureCode ::= 10
id-Abort                   ProcedureCode ::= 11

-- *****
--
-- Lists
--
-- *****

maxNrOfErrors      INTEGER ::= 256
maxSat             INTEGER ::= 16
maxSatAlmanac     INTEGER ::= 32
maxNrOfLevels     INTEGER ::= 256
maxNrOfPoints     INTEGER ::= 15
maxNrOfExpInfo    INTEGER ::= 32
maxNrOfMeasNCell  INTEGER ::= 32
maxNrOfMeasurements INTEGER ::= 16
maxNrOfSets       INTEGER ::= 3
maxRateMatching   INTEGER ::= 256
maxNrOfTFs        INTEGER ::= 32
maxTTI-count      INTEGER ::= 4
maxTS-1           INTEGER ::= 13
maxCCTrCH         INTEGER ::= 8
maxTF             INTEGER ::= 32
maxTFC            INTEGER ::= 1024

```

```

maxPRACH                INTEGER ::= 16
maxTrCH                  INTEGER ::= 32
maxTGPS                  INTEGER ::= 6
maxNoOfMeasurements     INTEGER ::= 16
maxCellMeas              INTEGER ::= 32
maxNrOfEDPCCH-PO-QUANTSTEPS  INTEGER ::= 8 -- FFS
maxNrOfRefETFCI-PO-QUANTSTEPS  INTEGER ::= 8 -- FFS
maxNrOfRefETFCIs        INTEGER ::= 8
maxSet                   INTEGER ::= 9

-- *****
--
-- IEs
--
-- *****

id-Cause                  ProtocolIE-ID ::= 1
id-CriticalityDiagnostics ProtocolIE-ID ::= 2
id-GPS-UTRAN-TRU         ProtocolIE-ID ::= 3
id-InformationExchangeID ProtocolIE-ID ::= 4
id-InformationExchangeObjectType-InfEx-Rprt ProtocolIE-ID ::= 5
id-InformationExchangeObjectType-InfEx-Rqst ProtocolIE-ID ::= 6
id-InformationExchangeObjectType-InfEx-Rsp ProtocolIE-ID ::= 7
id-InformationReportCharacteristics ProtocolIE-ID ::= 8
id-InformationType       ProtocolIE-ID ::= 9
id-GPS-MeasuredResultsList ProtocolIE-ID ::= 10
id-MethodType            ProtocolIE-ID ::= 11
id-RefPosition-InfEx-Rqst ProtocolIE-ID ::= 12
id-RefPosition-InfEx-Rsp ProtocolIE-ID ::= 13
id-RefPosition-Inf-Rprt  ProtocolIE-ID ::= 14
id-RequestedDataValue    ProtocolIE-ID ::= 15
id-RequestedDataValueInformation ProtocolIE-ID ::= 16
id-TransactionID         ProtocolIE-ID ::= 17
id-UE-PositionEstimate   ProtocolIE-ID ::= 18
id-CellId-MeasuredResultsSets ProtocolIE-ID ::= 20
id-OTDOA-MeasurementGroup ProtocolIE-ID ::= 22
id-AccuracyFulfilmentIndicator ProtocolIE-ID ::= 23
id-HorizontalAccuracyCode ProtocolIE-ID ::= 24
id-VerticalAccuracyCode  ProtocolIE-ID ::= 25
id-UTDOA-Group           ProtocolIE-ID ::= 26
id-RequestType           ProtocolIE-ID ::= 28
id-UE-PositioningCapability ProtocolIE-ID ::= 29
id-UC-id                 ProtocolIE-ID ::= 30
id-ResponseTime          ProtocolIE-ID ::= 31
id-PositioningPriority    ProtocolIE-ID ::= 32
id-ClientType            ProtocolIE-ID ::= 33
id-PositioningMethod     ProtocolIE-ID ::= 34
id-UTDOAPositioning      ProtocolIE-ID ::= 35
id-GPSAssistanceData     ProtocolIE-ID ::= 36
id-OTDOAAssistanceData   ProtocolIE-ID ::= 37
id-Positioning-ResponseTime ProtocolIE-ID ::= 38
id-EnvironmentCharacterisation ProtocolIE-ID ::= 39
id-PositionData          ProtocolIE-ID ::= 40

```

END

9.3.7 Container Definitions

```

-- *****
--
-- Container definitions
--
-- *****

PCAP-Containers {
itu-t (0) identified-organization (4) etsi (0) mobileDomain (0)
umts-Access (20) modules (3) pcap(4) version1 (1) pcap-Containers (5) }

DEFINITIONS AUTOMATIC TAGS ::=

BEGIN

-- *****

```

```

--
-- IE parameter types from other modules.
--
-- *****

IMPORTS
    Criticality,
    Presence,
    PrivateIE-ID,
    ProtocolIE-ID,
    maxPrivateIEs,
    maxProtocolExtensions,
    maxProtocolIEs
FROM PCAP-CommonDataTypes;

-- *****
--
-- Class Definition for Protocol IEs
--
-- *****

PCAP-PROTOCOL-IES ::= CLASS {
    &id                ProtocolIE-ID        UNIQUE,
    &criticality       Criticality,
    &Value,
    &presence          Presence
}
WITH SYNTAX {
    ID                &id
    CRITICALITY       &criticality
    TYPE              &Value
    PRESENCE          &presence
}

-- *****
--
-- Class Definition for Protocol Extensions
--
-- *****

PCAP-PROTOCOL-EXTENSION ::= CLASS {
    &id                ProtocolIE-ID UNIQUE,
    &criticality       Criticality,
    &Extension,
    &presence          Presence
}
WITH SYNTAX {
    ID                &id
    CRITICALITY       &criticality
    EXTENSION         &Extension
    PRESENCE          &presence
}

-- *****
--
-- Class Definition for Private IEs
--
-- *****

PCAP-PRIVATE-IES ::= CLASS {
    &id                PrivateIE-ID,
    &criticality       Criticality,
    &Value,
    &presence          Presence
}
WITH SYNTAX {
    ID                &id
    CRITICALITY       &criticality
    TYPE              &Value
    PRESENCE          &presence
}

-- *****
--
-- Container for Protocol IEs
--
-- *****

```

```

ProtocolIE-Container {PCAP-PROTOCOL-IES : IEsSetParam} ::=
  SEQUENCE (SIZE (0..maxProtocolIEs)) OF
    ProtocolIE-Field {{IEsSetParam}}

ProtocolIE-Field {PCAP-PROTOCOL-IES : IEsSetParam} ::= SEQUENCE {
  id                PCAP-PROTOCOL-IES.&id                ({IEsSetParam}),
  criticality       PCAP-PROTOCOL-IES.&criticality       ({IEsSetParam}@id),
  value            PCAP-PROTOCOL-IES.&Value            ({IEsSetParam}@id)
}

-- *****
--
-- Container Lists for Protocol IE Containers
--
-- *****

ProtocolIE-ContainerList {INTEGER : lowerBound, INTEGER : upperBound, PCAP-PROTOCOL-IES :
IEsSetParam} ::=
  SEQUENCE (SIZE (lowerBound..upperBound)) OF
    ProtocolIE-Container {{IEsSetParam}}

-- *****
--
-- Container for Protocol Extensions
--
-- *****

ProtocolExtensionContainer {PCAP-PROTOCOL-EXTENSION : ExtensionSetParam} ::=
  SEQUENCE (SIZE (1..maxProtocolExtensions)) OF
    ProtocolExtensionField {{ExtensionSetParam}}

ProtocolExtensionField {PCAP-PROTOCOL-EXTENSION : ExtensionSetParam} ::= SEQUENCE {
  id                PCAP-PROTOCOL-EXTENSION.&id                ({ExtensionSetParam}),
  criticality       PCAP-PROTOCOL-EXTENSION.&criticality       ({ExtensionSetParam}@id),
  extensionValue    PCAP-PROTOCOL-EXTENSION.&Extension        ({ExtensionSetParam}@id)
}

-- *****
--
-- Container for Private IEs
--
-- *****

PrivateIE-Container {PCAP-PRIVATE-IES : IEsSetParam } ::=
  SEQUENCE (SIZE (1.. maxPrivateIEs)) OF
    PrivateIE-Field {{IEsSetParam}}

PrivateIE-Field {PCAP-PRIVATE-IES : IEsSetParam} ::= SEQUENCE {
  id                PCAP-PRIVATE-IES.&id                ({IEsSetParam}),
  criticality       PCAP-PRIVATE-IES.&criticality       ({IEsSetParam}@id),
  value            PCAP-PRIVATE-IES.&Value            ({IEsSetParam}@id)
}

END

```

9.4 Message Transfer Syntax

PCAP shall use the ASN.1 Basic Packed Encoding Rules (BASIC-PER) Aligned Variant as transfer syntax, as specified in [9].

10 Handling of Unknown, Unforeseen and Erroneous Protocol Data

10.1 General

Protocol Error cases can be divided into three classes:

- Transfer Syntax Error.

- Abstract Syntax Error.
- Logical Error.

Protocol errors can occur in the following functions within a receiving node.

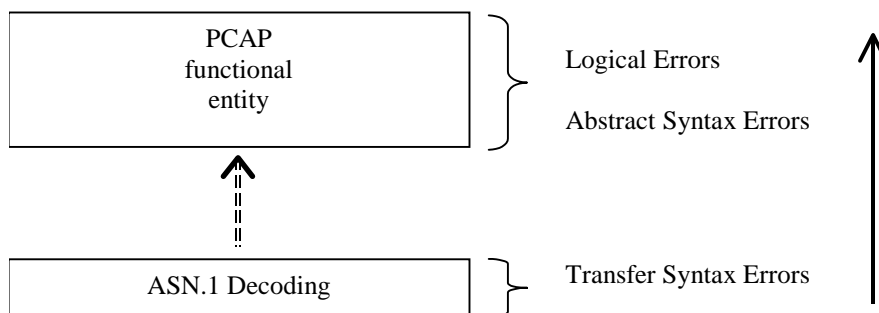

Figure 10: Protocol Errors in PCAP

The information stated in subclauses 10.2, 10.3 and 10.4, to be included in the message used when reporting an error, is what at minimum shall be included. Other optional information elements within the message may also be included, if available. This is also valid for the case when the reporting is done with a response message. The latter is an exception to what is stated in subclause 4.1.

10.2 Transfer Syntax Error

A Transfer Syntax Error occurs when the receiver is not able to decode the received physical message. Transfer syntax errors are always detected in the process of ASN.1 decoding. If a Transfer Syntax Error occurs, the receiver should initiate Error Indication procedure with appropriate cause value for the Transfer Syntax protocol error.

Examples for Transfer Syntax Errors are:

- Violation of value ranges in ASN.1 definition of messages. e.g.: If an IE has a defined value range of 0 to 10 (ASN.1: INTEGER (0..10)), and 12 will be received, then this will be treated as a transfer syntax error.
- Violation in list element constraints. e.g.: If a list is defined as containing 1 to 10 elements, and 12 elements will be received, then this case will be handled as a transfer syntax error.
- Missing mandatory elements in ASN.1 SEQUENCE definitions (as sent by the originator of the message).
- Wrong order of elements in ASN.1 SEQUENCE definitions (as sent by the originator of the message).

10.3 Abstract Syntax Error

10.3.1 General

An Abstract Syntax Error occurs when the receiving functional PCAP entity:

- 1) receives IEs or IE groups that cannot be understood (unknown IE id);
- 2) receives IEs for which the logical range is violated (e.g.: ASN.1 definition: 0 to 15, the logical range is 0 to 10 (values 11 to 15 are undefined), and 12 will be received; this case will be handled as an abstract syntax error using criticality information sent by the originator of the message);
- 3) does not receive IEs or IE groups but according to the specified presence of the concerning object, the IEs or IE groups should have been present in the received message;
- 4) receives IEs or IE groups that are defined to be part of that message in wrong order or with too many occurrences of the same IE or IE group;
- 5) receives IEs or IE groups but according to the conditional presence of the concerning object and the specified condition, the IEs or IE groups should not have been present in the received message.

Cases 1 and 2 (not comprehended IE/IE group) are handled based on received Criticality information. Case 3 (missing IE/IE group) is handled based on Criticality information and Presence information for the missing IE/IE group specified in the version of the specification used by the receiver. Case 4 (IEs or IE groups in wrong order or with too many occurrences) and Case 5 (erroneously present conditional IEs or IE groups) result in rejecting the procedure.

If an Abstract Syntax Error occurs, the receiver shall read the remaining message and shall then for each detected Abstract Syntax Error that belong to cases 1-3 act according to the Criticality Information and Presence Information for the IE/IE group due to which Abstract Syntax Error occurred in accordance with subclauses 10.3.4 and 10.3.5. The handling of cases 4 and 5 is specified in subclause 10.3.6.

10.3.2 Criticality Information

In the PCAP messages there is criticality information set for individual IEs and/or IE groups. This criticality information instructs the receiver how to act when receiving an IE or an IE group that is not comprehended, i.e. the entire item (IE or IE group) which is not (fully or partially) comprehended shall be treated in accordance with its own criticality information as specified in subclause 10.3.4.

In addition, the criticality information is used in case of the missing IE/IE group abstract syntax error (see subclause 10.3.5).

The receiving node shall take different actions depending on the value of the Criticality Information. The three possible values of the Criticality Information for an IE/IE group are:

- Reject IE.
- Ignore IE and Notify Sender.
- Ignore IE.

The following rules restrict when a receiving entity may consider an IE, an IE group, or an EP not comprehended (not implemented), and when action based on criticality information is applicable:

1. IE or IE group: When one new or modified IE or IE group is implemented for one EP from a standard version, then other new or modified IEs or IE groups specified for that EP in that standard version shall be considered comprehended by a receiving entity (some may still remain unsupported).
2. EP: The comprehension of different EPs within a standard version or between different standard versions is not mandated. Any EP that is not supported may be considered not comprehended, even if another EP from that standard version is comprehended, and action based on criticality shall be applied.

10.3.3 Presence Information

For many IEs/IE groups which are optional according to the ASN.1 transfer syntax, PCAP specifies separately if the presence of these IEs/IE groups is optional or mandatory with respect to RNS application by means of the presence field of the concerning object of class PCAP-PROTOCOL-IES, PCAP-PROTOCOL-IES-PAIR, PCAP-PROTOCOL-EXTENSION or PCAP-PRIVATE-IES.

The presence field of the indicated classes supports three values:

1. Optional;
2. Conditional;
3. Mandatory.

If an IE/IE group is not included in a received message and the presence of the IE/IE group is mandatory or the presence is conditional and the condition is true according to the version of the specification used by the receiver, an abstract syntax error occurs due to a missing IE/IE group.

If an IE/IE group is included in a received message and the presence of the IE/IE group is conditional and the condition is false according to the version of the specification used by the receiver, an abstract syntax error occurs due to this erroneously present conditional IE/IE group.

10.3.4 Not comprehended IE/IE group

10.3.4.1 Procedure Code

The receiving node shall treat the different types of received criticality information of the *Procedure Code* IE according to the following:

Reject IE:

- If a message is received with a *Procedure Code* IE marked with "*Reject IE*" which the receiving node does not comprehend, the receiving node shall reject the procedure using the Error Indication procedure.

Ignore IE and Notify Sender:

- If a message is received with a *Procedure Code* IE marked with "*Ignore IE and Notify Sender*" which the receiving node does not comprehend, the receiving node shall ignore the procedure and initiate the Error Indication procedure.

Ignore IE:

- If a message is received with a *Procedure Code* IE marked with "*Ignore IE*" which the receiving node does not comprehend, the receiving node shall ignore the procedure.

When using the Error Indication procedure to reject a procedure or to report an ignored procedure it shall include the *Procedure Code* IE, the *Triggering Message* IE, and the *Procedure Criticality* IE in the *Criticality Diagnostics* IE.

10.3.4.1A Type of Message

When the receiving node cannot decode the *Type of Message* IE, the Error Indication procedure shall be initiated with an appropriate cause value.

10.3.4.2 IEs other than the Procedure Code and Type of Message

The receiving node shall treat the different types of received criticality information of an IE/IE group other than the *Procedure Code* IE and *Type of Message* IE according to the following:

Reject IE:

- If a message *initiating* a procedure is received containing one or more IEs/IE groups marked with "*Reject IE*" which the receiving node does not comprehend; none of the functional requests of the message shall be executed. The receiving node shall reject the procedure and report the rejection of one or more IEs/IE groups using the message normally used to report unsuccessful outcome of the procedure. In case the information received in the initiating message was insufficient to determine a value for all IEs that are required to be present in the message used to report the unsuccessful outcome of the procedure, the receiving node shall instead terminate the procedure and initiate the Error Indication procedure.
- If a message *initiating* a procedure that does not have a message to report unsuccessful outcome is received containing one or more IEs/IE groups marked with "*Reject IE*" which the receiving node does not comprehend, the receiving node shall terminate the procedure and initiate the Error Indication procedure.
- If a *response* message is received containing one or more IEs/IE groups marked with "*Reject IE*", that the receiving node does not comprehend, the receiving node shall consider the procedure as unsuccessfully terminated and initiate local error handling.

Ignore IE and Notify Sender:

- If a message *initiating* a procedure is received containing one or more IEs/IE groups marked with "*Ignore IE and Notify Sender*" which the receiving node does not comprehend, the receiving node shall ignore the content of the not comprehended IEs/IE groups, continue with the procedure as if the not comprehended IEs/IE groups were not received (except for the reporting) using the understood IEs/IE groups, and report in the response message of the procedure that one or more IEs/IE groups have been ignored. In case the information received in the initiating message was insufficient to determine a value for all IEs that are required to be present in the response message, the receiving node shall instead terminate the procedure and initiate the Error Indication procedure.

- If a message *initiating* a procedure that does not have a message to report the outcome of the procedure is received containing one or more IEs/IE groups marked with "*Ignore IE and Notify Sender*" which the receiving node does not comprehend, the receiving node shall ignore the content of the not comprehended IEs/IE groups, continue with the procedure as if the not comprehended IEs/IE groups were not received (except for the reporting) using the understood IEs/IE groups, and initiate the Error Indication procedure to report that one or more IEs/IE groups have been ignored.
- If a *response* message is received containing one or more IEs/IE groups marked with "*Ignore IE and Notify Sender*" which the receiving node does not comprehend, the receiving node shall ignore the content of the not comprehended IEs/IE groups, continue with the procedure as if the not comprehended IEs/IE groups were not received (except for the reporting) using the understood IEs/IE groups and initiate the Error Indication procedure.

Ignore IE:

- If a message *initiating* a procedure is received containing one or more IEs/IE groups marked with "*Ignore IE*" which the receiving node does not comprehend, the receiving node shall ignore the content of the not comprehended IEs/IE groups and continue with the procedure as if the not comprehended IEs/IE groups were not received using the understood IEs/IE groups.
- If a *response* message is received containing one or more IEs/IE groups marked with "*Ignore IE*" which the receiving node does not comprehend, the receiving node shall ignore the content of the not comprehended IEs/IE groups.

When reporting not comprehended IEs/IE groups marked with "*Reject IE*" or "*Ignore IE and Notify Sender*" using a response message defined for the procedure, the *Information Element Criticality Diagnostics* IE shall be included in the *Criticality Diagnostics* IE for each reported IE/IE group. The *Repetition Number* IE shall be included in the *Information Element Criticality Diagnostics* IE if the reported IE/IE group was part of a "SEQUENCE OF" definition.

When reporting not comprehended IEs/IE groups marked with "*Reject IE*" or "*Ignore IE and Notify Sender*" using the Error Indication procedure, the *Procedure Code* IE, the *Triggering Message* IE, *Procedure Criticality* IE, the *Transaction Id* IE, and the *Information Element Criticality Diagnostics* IE shall be included in the *Criticality Diagnostics* IE for each reported IE/IE group. The *Repetition Number* IE shall be included in the *Information Element Criticality Diagnostics* IE if the reported IE/IE group was part of a "SEQUENCE OF" definition.

10.3.5 Missing IE or IE group

The receiving node shall treat the missing IE/IE group according to the criticality information for the missing IE/IE group in the received message specified in the version of the present document used by the receiver:

Reject IE:

- If a received message *initiating* a procedure is missing one or more IEs/IE groups with specified criticality "*Reject IE*"; none of the functional requests of the message shall be executed. The receiving node shall reject the procedure and report the missing IEs/IE groups using the message normally used to report unsuccessful outcome of the procedure. In case the information received in the initiating message was insufficient to determine a value for all IEs that are required to be present in the message used to report the unsuccessful outcome of the procedure, the receiving node shall instead terminate the procedure and initiate the Error Indication procedure.
- If a received message *initiating* a procedure that does not have a message to report unsuccessful outcome is missing one or more IEs/IE groups with specified criticality "*Reject IE*", the receiving node shall initiate the Error Indication procedure.
- If a received *response* message is missing one or more IEs/IE groups with specified criticality "*Reject IE*", the receiving node shall consider the procedure as unsuccessfully terminated and initiate local error handling.

Ignore IE and Notify Sender:

- If a received message *initiating* a procedure is missing one or more IEs/IE groups with specified criticality "*Ignore IE and Notify Sender*", the receiving node shall ignore that those IEs are missing and continue with the procedure based on the other IEs/IE groups present in the message and report in the response message of the procedure that one or more IEs/IE groups were missing. In case the information received in the initiating message was insufficient to determine a value for all IEs that are required to be present in the response message, the receiving node shall instead terminate the procedure and initiate the Error Indication procedure.

- If a received message *initiating* a procedure that does not have a message to report the outcome of the procedure is missing one or more IEs/IE groups with specified criticality "*Ignore IE and Notify Sender*", the receiving node shall ignore that those IEs are missing and continue with the procedure based on the other IEs/IE groups present in the message and initiate the Error Indication procedure to report that one or more IEs/IE groups were missing.
- If a received *response* message is missing one or more IEs/IE groups with specified criticality "*Ignore IE and Notify Sender*", the receiving node shall ignore that those IEs are missing and continue with the procedure based on the other IEs/IE groups present in the message and initiate the Error Indication procedure to report that one or more IEs/IE groups were missing.

Ignore IE:

- If a received message *initiating* a procedure is missing one or more IEs/IE groups with specified criticality "*Ignore IE*", the receiving node shall ignore that those IEs are missing and continue with the procedure based on the other IEs/IE groups present in the message.
- If a received *response* message is missing one or more IEs/IE groups with specified criticality "*Ignore IE*", the receiving node shall ignore that those IEs/IE groups are missing.

When reporting missing IEs/IE groups with specified criticality "*Reject IE*" or "*Ignore IE and Notify Sender*" using a response message defined for the procedure, the *Information Element Criticality Diagnostics* IE shall be included in the *Criticality Diagnostics* IE for each reported IE/IE group.

When reporting missing IEs/IE groups with specified criticality "*Reject IE*" or "*Ignore IE and Notify Sender*" using the Error Indication procedure, the *Procedure Code* IE, the *Triggering Message* IE, *Procedure Criticality* IE, the *Transaction Id* IE, and the *Information Element Criticality Diagnostics* IE shall be included in the *Criticality Diagnostics* IE for each reported IE/IE group.

10.3.6 IEs or IE groups received in wrong order or with too many occurrences or erroneously present

If a message with IEs or IE groups in wrong order or with too many occurrences is received or if IEs or IE groups with a conditional presence are present when the condition is not met (i.e. erroneously present), the receiving node shall behave according to the following:

- If a message *initiating* a procedure is received containing IEs or IE groups in wrong order or with too many occurrences or erroneously present, none of the functional requests of the message shall be executed. The receiving node shall reject the procedure and report the cause value "Abstract Syntax Error (Falsely Constructed Message)" using the message normally used to report unsuccessful outcome of the procedure. In case the information received in the initiating message was insufficient to determine a value for all IEs that are required to be present in the message used to report the unsuccessful outcome of the procedure, the receiving node shall instead terminate the procedure and initiate the Error Indication.
- If a message *initiating* a procedure that does not have a message to report unsuccessful outcome is received containing IEs or IE groups in wrong order or with too many occurrences or erroneously present, the receiving node shall terminate the procedure and initiate the Error Indication procedure, and use cause value "Abstract Syntax Error (Falsely Constructed Message)".
- If a *response* message is received containing IEs or IE groups in wrong order or with too many occurrences or erroneously present, the receiving node shall consider the procedure as unsuccessfully terminated and initiate local error handling.

10.4 Logical Error

Logical error situations occur when a message is comprehended correctly, but the information contained within the message is not valid (i.e. semantic error), or describes a procedure which is not compatible with the state of the receiver. In these conditions, the following behaviour shall be performed (unless otherwise specified) as defined by the class of the elementary procedure, irrespective of the criticality of the IEs/IE groups containing the erroneous values.

Class 1:

Protocol Causes:

Where the logical error occurs in a request message of a class 1 procedure, and the procedure has a message to report this unsuccessful outcome, this message shall be sent with an appropriate cause value. Typical cause values are:

1. Semantic Error.
2. Message not compatible with receiver state.

Where the logical error is contained in a request message of a class 1 procedure, and the procedure does not have a message to report this unsuccessful outcome, the procedure shall be terminated and the Error Indication procedure shall be initiated with an appropriate cause value.

Where the logical error exists in a response message of a class 1 procedure, the procedure shall be considered as unsuccessfully terminated and local error handling shall be initiated.

Class 2:

Where the logical error occurs in a message of a class 2 procedure, the procedure shall be terminated and the Error Indication procedure shall be initiated with an appropriate cause value.

10.5 Exceptions

The error handling for all the cases described hereafter shall take precedence over any other error handling described in the other subclauses of clause 10.

- If any type of error (Transfer Syntax Error, Abstract Syntax Error or Logical Error) is detected in the ERROR INDICATION message, it shall not trigger the Error Indication procedure in the receiving Node but local error handling.
- In case a response message or Error Indication message needs to be returned, but the information necessary to determine the receiver of that message is missing, the procedure shall be considered as unsuccessfully terminated and local error handling shall be initiated.
- If an error that terminates a procedure occurs, the returned cause value shall reflect the error that caused the termination of the procedure even if one or more abstract syntax errors with criticality 'ignore and notify' have earlier occurred within the same procedure.

Annex A (informative): Guidelines for Usage of the Criticality Diagnostics IE

A.1 EXAMPLE MESSAGE Layout

Assume the following message format:

Table A.1

IE/Group Name	Presence	Range	IE type and reference	Semantics description	Criticality	Assigned Criticality
Message Type	M				YES	Reject
Transaction ID	M				-	
A	M				YES	reject
B	M				YES	reject
>E		1..<maxE>			EACH	ignore
>>F		1..<maxF>			-	
>>>G		0..3, ...			EACH	ignore
>>H		1..<maxH>			EACH	ignore
>>>G		0..3, ...			EACH	ignore and notify
>>G	M				YES	reject
>>J		1..<maxJ>			-	
>>>G		0..3, ...			EACH	reject
C	M				YES	reject
>K		1..<maxK>			EACH	ignore and notify
>>L		1..<maxL>			-	
>>>M	O				-	
D	M				YES	reject

NOTE: The IEs F, J, and L do not have assigned criticality. The IEs F, J, and L are consequently realised as the ASN.1 type SEQUENCE OF of "ordinary" ASN.1 type, e.g. INTEGER. On the other hand, the repeatable IEs with assigned criticality are realised as the ASN.1 type SEQUENCE OF of an IE object, e.g. ProtocolIE-Single-Container.

For the corresponding ASN.1 layout, see clause A.4.

A.2 Example on a Received EXAMPLE MESSAGE

Assume further more that a received message based on the above tabular format is according to figure A.1.

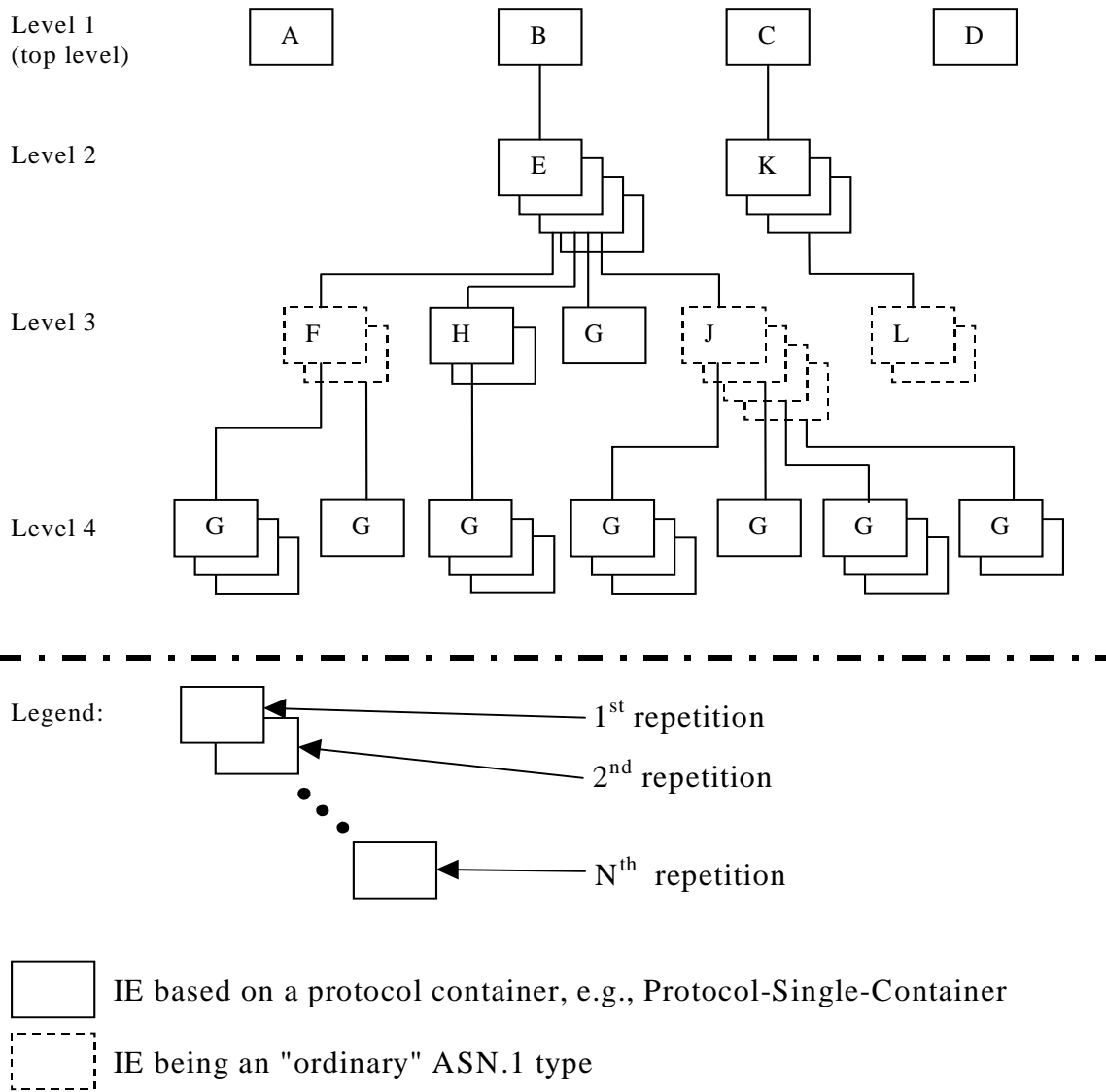

Figure A.1: Example of content of a received PCAP message based on the EXAMPLE MESSAGE

A.3 Content of Criticality Diagnostics

A.3.1 Example 1

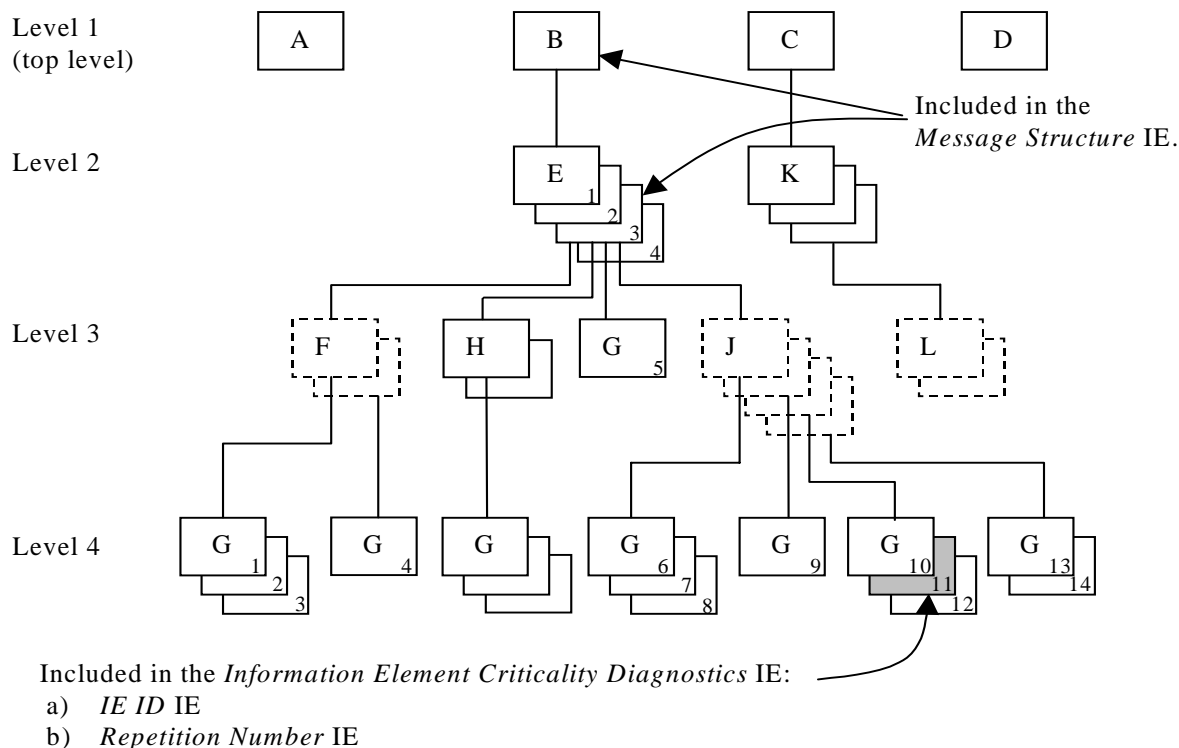

Figure A.2: Example of a received PCAP message containing a not comprehended IE

If there is an error within the instance marked as grey in the IE G in the IE J shown in the figure A.2, this will be reported within the *Information Element Criticality Diagnostics* IE within the *Criticality Diagnostics* IEs as in table A.2.

Table A.2

IE name	Value	Comment
IE Criticality	Reject	Criticality for IE on the reported level, i.e. level 4.
IE ID	id-G	IE ID from the reported level, i.e. level 4.
Repetition Number	11	Repetition number on the reported level, i.e. level 4. (Since the IE E (level 2) is the lowest level included in the <i>Message Structure</i> IE this is the eleventh occurrence of IE G within the IE E (level 2).
Type of Error	not understood	
<i>Message Structure, first repetition</i>		
>IE ID	id-B	IE ID from level 1.
<i>Message Structure, second repetition</i>		
>IE ID	id-E	IE ID from the lowest level above the reported level, i.e. level 2.
>Repetition Number	3	Repetition number from the lowest level above the reported level, i.e. level 2.

NOTE 1: The IE J on level 3 cannot be included in the *Message Structure* IE since they have no criticality of their own.

NOTE 2: The repetition number of the reported IE indicates the number of repetitions of IE G received up to the detected erroneous repetition, counting all occurrences of the IE G below the same instance of the previous level with assigned criticality (instance 3 of IE E on level 2).

A.3.2 Example 2

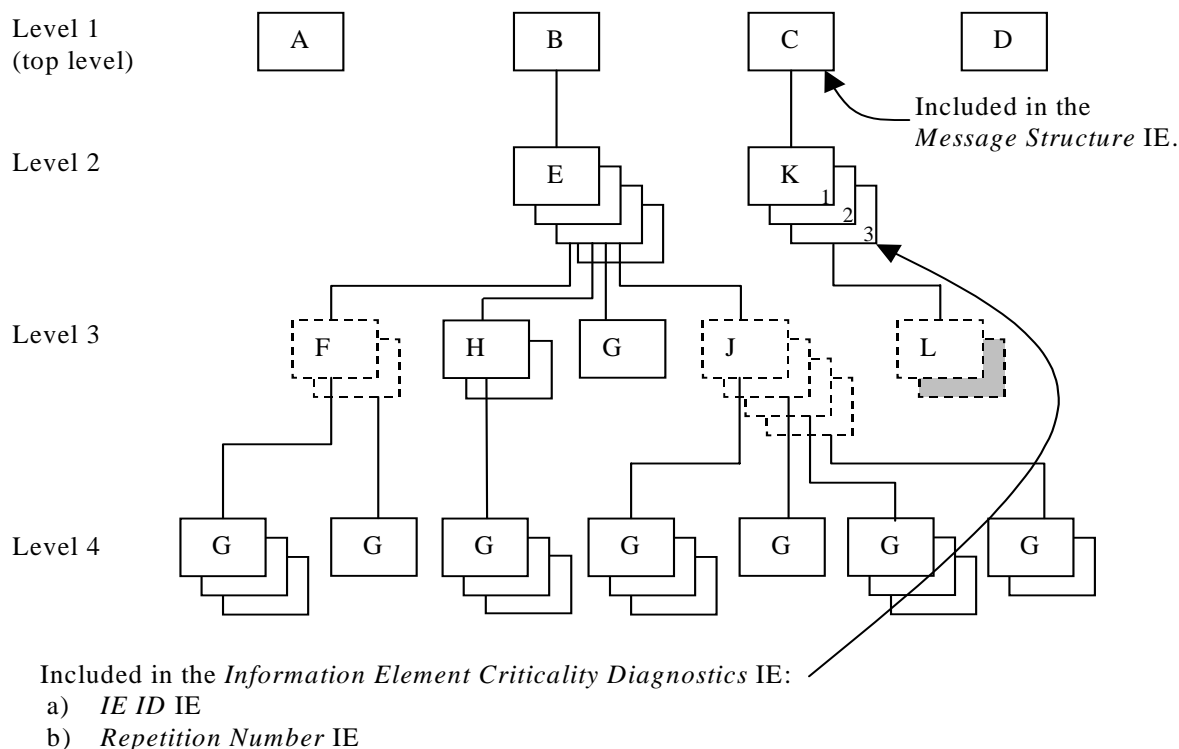

Figure A.3: Example of a received PCAP message containing a not comprehended IE

If there is an error within the second instance (marked as grey) in the sequence (IE L in the tabular format) on level 3 below IE K in the structure shown in the figure A.3, this will be reported within the *Information Element Criticality Diagnostics* IE within the *Criticality Diagnostics* IEAs in table A.3.

Table A.3

IE name	Value	Comment
IE Criticality	ignore and notify	Criticality for IE on the reported level, i.e. level 2.
IE ID	id-K	IE ID from the reported level, i.e. level 2.
Repetition Number	3	Repetition number on the reported level, i.e. level 2.
Type of Error	not understood	
<i>Message Structure, first repetition</i>		
>IE ID	id-C	IE ID from the lowest level above the reported level, i.e. level 1.

NOTE: The IE L on level 3 cannot be reported individually included in the *Message Structure* IE since it has no criticality of its own.

A.3.3 Example 3

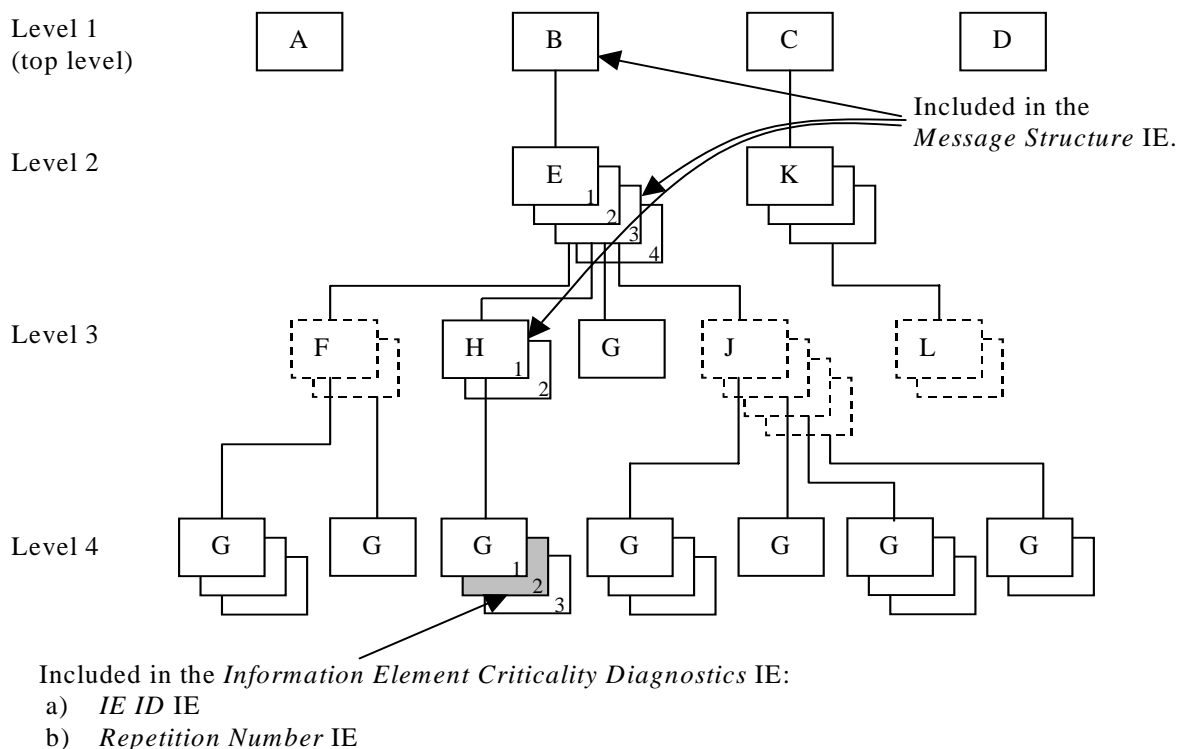

Figure A.4: Example of a received PCAP message containing a not comprehended IE

If there is an error within the instance marked as grey in the IE G in the IE H shown in the figure A.4, this will be reported within the *Information Element Criticality Diagnostics IE* within the *Criticality Diagnostics IE*s in table A.4.

Table A.4

IE name	Value	Comment
IE Criticality	ignore and notify	Criticality for IE on the reported level, i.e. level 4.
IE ID	id-G	IE ID from the reported level, i.e. level 4.
Repetition Number	2	Repetition number on the reported level, i.e. level 4.
Type of Error	not understood	
<i>Message Structure, first repetition</i>		
>IE ID	id-B	IE ID from level 1.
<i>Message Structure, second repetition</i>		
>IE ID	id-E	IE ID from level 2.
>Repetition Number	3	Repetition number from level 2.
<i>Message Structure, third repetition</i>		
>IE ID	id-H	IE ID from the lowest level above the reported level, i.e. level 3.
>Repetition Number	1	Repetition number from the lowest level above the reported level, i.e. level 3.

NOTE: The repetition number of level 4 indicates the number of repetitions of IE G received up to the detected erroneous repetition, counted below the same instance of the previous level with assigned criticality (instance 1 of IE H on level 3).

A.3.4 Example 4

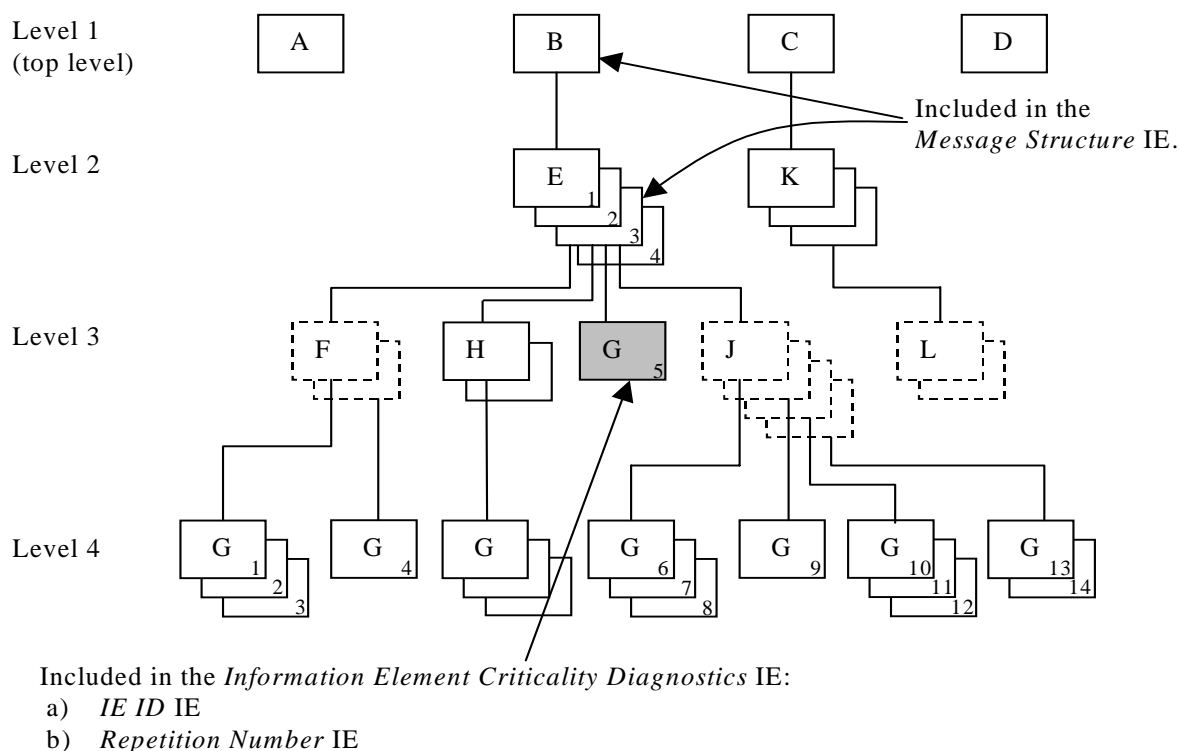

Figure A.5: Example of a received PCAP message containing a not comprehended IE

If there is an error within the instance marked as grey in the IE G in the IE E shown in the figure A.5, this will be reported within the *Information Element Criticality Diagnostics* IE within the *Criticality Diagnostics* IE, as in table A.5.

Table A.5

IE name	Value	Comment
IE Criticality	Reject	Criticality for IE on the reported level, i.e. level 3.
IE ID	id-G	IE ID from the reported level, i.e. level 3.
Repetition Number	5	Repetition number on the reported level, i.e. level 3. (Since the IE E (level 2) is the lowest level included in the <i>Message Structure</i> IE this is the fifth occurrence of IE G within the IE E (level 2).
Type of Error	not understood	
Message Structure, <i>first repetition</i>		
>IE ID	id-B	IE ID from level 1.
Message Structure, <i>second repetition</i>		
>IE ID	id-E	IE ID from the lowest level above the reported level, i.e. level 2.
>Repetition Number	3	Repetition number from the lowest level above the reported level, i.e. level 2.

NOTE: The repetition number of the reported IE indicates the number of repetitions of IE G received up to the detected erroneous repetition, counting all occurrences of the IE G below the same instance of the previous level with assigned criticality (instance 3 of IE E on level 2).

A.3.5 Example 5

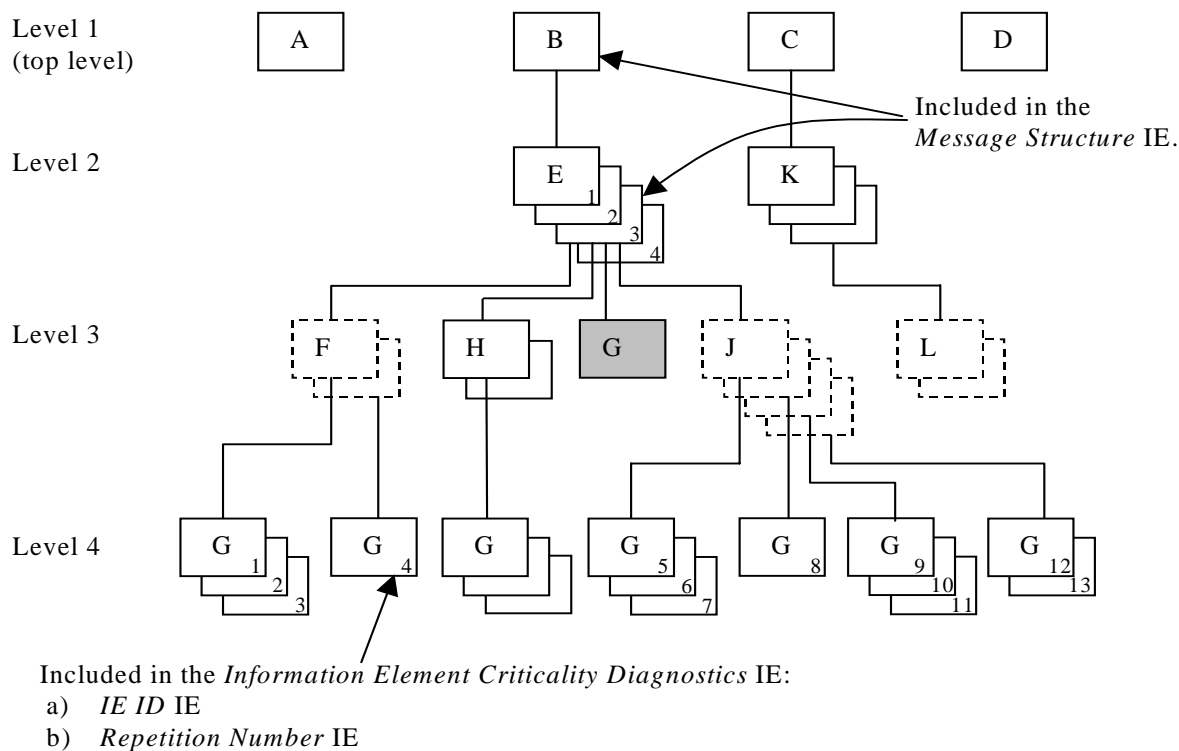

Figure A.6: Example of a received PCAP message with a missing IE

If the instance marked as grey in the IE G in the IE E shown in the figure A.6, is missing this will be reported within the *Information Element Criticality Diagnostics* IE within the *Criticality Diagnostics* IE, as in table A.6.

Table A.6

IE name	Value	Comment
IE Criticality	reject	Criticality for IE on the reported level, i.e. level 3.
IE ID	id-G	IE ID from the reported level, i.e. level 3.
Repetition Number	4	Repetition number up to the missing IE on the reported level, i.e. level 3. (Since the IE E (level 2) is the lowest level included in the <i>Message Structure</i> IE there have been four occurrences of IE G within the IE E (level 2) up to the missing occurrence.
Type of Error	missing	
<i>Message Structure, first repetition</i>		
>IE ID	id-B	IE ID from level 1.
<i>Message Structure, second repetition</i>		
>IE ID	id-E	IE ID from the lowest level above the reported level, i.e. level 2.
>Repetition Number	3	Repetition number from the lowest level above the reported level, i.e. level 2.

NOTE: The repetition number of the reported IE indicates the number of repetitions of IE G received up to but not including the missing occurrence, counting all occurrences of the IE G below the same instance of the previous level with assigned criticality (instance 3 of IE E on level 2).

A.4 ASN.1 of EXAMPLE MESSAGE

```

ExampleMessage ::= SEQUENCE {
    ProtocolIEs          ProtocolIE-Container          {{ExampleMessage-IEs}},
    ProtocolExtensions  ProtocolExtensionContainer  {{ExampleMessage-Extensions}}  OPTIONAL,
    ...
}

ExampleMessage-IEs PCAP-PROTOCOL-IES ::= {
    { ID id-A    CRITICALITY reject  TYPE A  PRESENCE mandatory } |
    { ID id-B    CRITICALITY reject  TYPE B  PRESENCE mandatory } |
    { ID id-C    CRITICALITY reject  TYPE C  PRESENCE mandatory } |
    { ID id-D    CRITICALITY reject  TYPE D  PRESENCE mandatory } ,
    ...
}

B ::= SEQUENCE {
    e          E-List,
    iE-Extensions  ProtocolExtensionContainer { {B-ExtIEs} }  OPTIONAL,
    ...
}

B-ExtIEs PCAP-PROTOCOL-EXTENSION ::= {
    ...
}

E-List ::= SEQUENCE (SIZE (1..maxE)) OF ProtocolIE-Single-Container { {E-IEs} }

E-IEs PCAP-PROTOCOL-IES ::= {
    { ID id-E    CRITICALITY ignore  TYPE E  PRESENCE mandatory }
}

E ::= SEQUENCE {
    f          F-List,
    h          H-List,
    g          G-List1,
    j          J-List,
    iE-Extensions  ProtocolExtensionContainer { {E-ExtIEs} }  OPTIONAL,
    ...
}

E-ExtIEs PCAP-PROTOCOL-EXTENSION ::= {
    ...
}

F-List ::= SEQUENCE (SIZE (1..maxF)) OF F

F ::= SEQUENCE {
    g          G-List2 OPTIONAL,
    iE-Extensions  ProtocolExtensionContainer { {F-ExtIEs} }  OPTIONAL,
    ...
}

F-ExtIEs PCAP-PROTOCOL-EXTENSION ::= {
    ...
}

G-List2 ::= SEQUENCE (SIZE (1..3, ...)) OF ProtocolIE-Single-Container { {G2-IEs} }

G2-IEs PCAP-PROTOCOL-IES ::= {
    { ID id-G    CRITICALITY ignore  TYPE G  PRESENCE mandatory }
}

H-List ::= SEQUENCE (SIZE (1..maxH)) OF ProtocolIE-Single-Container { {H-IEs} }

H-IEs PCAP-PROTOCOL-IES ::= {
    { ID id-H    CRITICALITY ignore  TYPE H  PRESENCE mandatory }
}

H ::= SEQUENCE {
    g          G-List3 OPTIONAL,
    iE-Extensions  ProtocolExtensionContainer { {H-ExtIEs} }  OPTIONAL,
    ...
}

H-ExtIEs PCAP-PROTOCOL-EXTENSION ::= {
    ...
}

```

```

}
G-List3 ::= SEQUENCE (SIZE (1..3, ...)) OF ProtocolIE-Single-Container { {G3-IEs} }
G3-IEs PCAP-PROTOCOL-IES ::= {
  { ID id-G    CRITICALITY notify  TYPE G  PRESENCE mandatory }
}
G-List1 ::= ProtocolIE-Single-Container { {G1-IEs} }
G1-IEs PCAP-PROTOCOL-IES ::= {
  { ID id-G    CRITICALITY reject  TYPE G  PRESENCE mandatory }
}
J-List ::= SEQUENCE (SIZE (1..maxJ)) OF J
J ::= SEQUENCE {
  g          G-List4 OPTIONAL,
  iE-Extensions ProtocolExtensionContainer { {J-ExtIEs} } OPTIONAL,
  ...
}
J-ExtIEs PCAP-PROTOCOL-EXTENSION ::= {
  ...
}
G-List4 ::= SEQUENCE (SIZE (1..3, ...)) OF ProtocolIE-Single-Container { {G4-IEs} }
G4-IEs PCAP-PROTOCOL-IES ::= {
  { ID id-G    CRITICALITY reject  TYPE G  PRESENCE mandatory }
}
C ::= SEQUENCE {
  k          K-List,
  iE-Extensions ProtocolExtensionContainer { {C-ExtIEs} } OPTIONAL,
  ...
}
C-ExtIEs PCAP-PROTOCOL-EXTENSION ::= {
  ...
}
K-List ::= SEQUENCE (SIZE (1..maxK)) OF ProtocolIE-Single-Container { {K-IEs} }
K-IEs PCAP-PROTOCOL-IES ::= {
  { ID id-K    CRITICALITY notify  TYPE K  PRESENCE mandatory }
}
K ::= SEQUENCE {
  l          L-List,
  iE-Extensions ProtocolExtensionContainer { {K-ExtIEs} } OPTIONAL,
  ...
}
K-ExtIEs PCAP-PROTOCOL-EXTENSION ::= {
  ...
}
L-List ::= SEQUENCE (SIZE (1..maxL)) OF L
L ::= SEQUENCE {
  m          M OPTIONAL,
  iE-Extensions ProtocolExtensionContainer { {L-ExtIEs} } OPTIONAL,
  ...
}
L-ExtIEs PCAP-PROTOCOL-EXTENSION ::= {
  ...
}
ExampleMessage-Extensions PCAP-PROTOCOL-EXTENSION ::= {
  ...
}

```

Annex B (informative): Change history

Change history							
Date	TSG #	TSG Doc.	CR	Rev	Subject/Comment	Old	New
06/2001	12	RP-010402			Approved at TSG RAN #12 and placed under Change Control	-	5.0.0
09/2001	13	RP-010603	002	1	Correction to the Error handling of the ERROR INDICATION message	5.0.0	5.1.0
09/2001	13	RP-010603	003		Proposed CR to 25.453 on Semantics Description of C/No	5.0.0	5.1.0
09/2001	13	RP-010603	004		Proposed CR to 25.453 on Clause 10	5.0.0	5.1.0
09/2001	13	RP-010603	005	1	Error handling of the Erroneously Present Conditional Ies	5.0.0	5.1.0
09/2001	13	RP-010603	006	1	Clarification of chapter 10	5.0.0	5.1.0
09/2001	13	RP-010603	007		PCAP Criticality	5.0.0	5.1.0
12/2001	14	RP-010875	008	1	Bitstrings ordering	5.1.0	5.2.0
12/2001	14	RP-010875	009	1	Reference corrections	5.1.0	5.2.0
12/2001	14	RP-010875	010	1	Clarification for the definition of the ASN.1 constants	5.1.0	5.2.0
12/2001	14	RP-010875	012	1	Procedure Code Criticality in Error Indication	5.1.0	5.2.0
12/2001	14	RP-010875	013	2	Addition of amendment to clarify the PER encoding of bitstrings	5.1.0	5.2.0
12/2001	14	RP-010875	014	1	Clarification of the Transaction ID	5.1.0	5.2.0
12/2001	14	RP-010875	015		Correction the Clause 10 Error Handling	5.1.0	5.2.0
-3/2002	15	RP-020211	016		Modification on the Object Identifier	5.2.0	5.3.0
06/2002	16	RP-020432	017	2	Criticality Information Decoding Failure Handling	5.3.0	5.4.0
06/2002	16	RP-020432	018	1	Clarification for the usage of the cause value	5.3.0	5.4.0
03/2003	19	RP-030065	023		CR on GPS Almanac and Satellite Health	5.4.0	5.5.0
03/2003	19	RP-030065	024		CR on GPS Measured Results	5.4.0	5.5.0
03/2003	19	RP-030067	026		Alignment of 'Uncertainty Ellipse' with RRC	5.4.0	5.5.0
03/2003	19	RP-030070	027		Correction for the Information Exchange Initiation procedure	5.4.0	5.5.0
03/2003	19	RP-030084	022	2	CR on revising the position calculation function and definition of SAS to support all REL-4 UE positioning methods	5.5.0	6.0.0
06/2003	20	RP-030324	032	1	Alignment of the Requested Data Value Information IE description	6.0.0	6.1.0
06/2003	20	RP-030325	034		GPS trigger condition	6.0.0	6.1.0
06/2003	20	RP-030341	035		Position Calculation Extension for TDD	6.0.0	6.1.0
06/2003	20	RP-030322	037	1	'On Modification' and 'Periodic' reporting alignment for Information Exchange procedures	6.0.0	6.1.0
06/2003	20	RP-030322	044		CR on Criticality Aspects	6.0.0	6.1.0
06/2003	20	RP-030322	045		CR on Information Exchange Initiation Request for GPS Navigation Model	6.0.0	6.1.0
06/2003	20	RP-030322	046		CR on DGPS Parameters	6.0.0	6.1.0
06/2003	20	RP-030322	047		CR on Removal of Information Exchange Object Type	6.0.0	6.1.0
06/2003	20	RP-030322	048		CR on Information Report of GPS Almanac and Satellite Health	6.0.0	6.1.0
06/2003	20	RP-030326	050		Correction of Failure message used for logical errors	6.0.0	6.1.0
09/2003	21	RP-030442	052		Correction to an incorrect implementation in the Requested Data Value Information IE	6.1.0	6.2.0
09/2003	21	RP-030445	054		Alignment of title and sub-clause text of chapter 10.3.4.2	6.1.0	6.2.0
09/2003	21	RP-030446	059		Removal of the note in chapter 10	6.1.0	6.2.0
09/2003	21	RP-030454	060		Improvement of position calculation with pathloss	6.1.0	6.2.0
12/2003	22	RP-030697	061		Improvement of position calculation through set enlargement	6.2.0	6.3.0
12/2003	22	RP-030683	064		Information Exchange Initiation behavior correction	6.2.0	6.3.0
03/2004	23	RP-040053	068		Alignment with 23.032 correction of Included Angle for Ellipsoid Arc	6.3.0	6.4.0
03/2004	23	RP-040075	069		Initial UE Position IE only mandatory necessary for GPS	6.3.0	6.4.0
03/2004	23	RP-040072	071		PCAP Review	6.3.0	6.4.0
06/2004	24	RP-040184	072	1	Correction to usage of INITIAL UE POSITION	6.4.0	6.5.0
09/2004	25	RP-040306	074	1	Introduction of the requested accuracy and an indication of achieved accuracy in Position Calculation procedure over Iupc interface	6.5.0	6.6.0
12/2004	26	RP-040441	076		outdated ITU-T reference	6.6.0	6.7.0
03/2005	27	RP-050055	078	1	Corrections to descriptions of GPS Almanac and Ephemeris fields	6.7.0	6.8.0
06/2005	28	RP-050217	082	2	Correction of deletion of Information Exchange Context	6.8.0	6.9.0
09/2005	29	RP-050441	083	1	Addition of the U-TDOA positioning method to the UTRAN	6.9.0	7.0.0
12/2005	30	RP-050705	086	2	Addition of TDD aspects of the U-TDOA positioning method	7.0.0	7.1.0
12/2005	30	RP-050701	087		PCAP Review	7.0.0	7.1.0
12/2005	30	RP-050706	088		Wording Alignment for Procedure Text	7.0.0	7.1.0

History

Document history		
V7.1.0	December 2005	Publication