

ETSI TS 125 444 V9.0.2 (2010-02)

Technical Specification

Universal Mobile Telecommunications System (UMTS); Iuh data transport (3GPP TS 25.444 version 9.0.2 Release 9)



Reference

DTS/TSGR-0325444v902

Keywords

UMTS

ETSI

650 Route des Lucioles
F-06921 Sophia Antipolis Cedex - FRANCE

Tel.: +33 4 92 94 42 00 Fax: +33 4 93 65 47 16

Siret N° 348 623 562 00017 - NAF 742 C
Association à but non lucratif enregistrée à la
Sous-Préfecture de Grasse (06) N° 7803/88

Important notice

Individual copies of the present document can be downloaded from:

<http://www.etsi.org>

The present document may be made available in more than one electronic version or in print. In any case of existing or perceived difference in contents between such versions, the reference version is the Portable Document Format (PDF). In case of dispute, the reference shall be the printing on ETSI printers of the PDF version kept on a specific network drive within ETSI Secretariat.

Users of the present document should be aware that the document may be subject to revision or change of status. Information on the current status of this and other ETSI documents is available at

<http://portal.etsi.org/tb/status/status.asp>

If you find errors in the present document, please send your comment to one of the following services:

http://portal.etsi.org/chaicor/ETSI_support.asp

Copyright Notification

No part may be reproduced except as authorized by written permission.
The copyright and the foregoing restriction extend to reproduction in all media.

© European Telecommunications Standards Institute 2010.
All rights reserved.

DECT™, **PLUGTESTS™**, **UMTS™**, **TIPHON™**, the TIPHON logo and the ETSI logo are Trade Marks of ETSI registered for the benefit of its Members.

3GPP™ is a Trade Mark of ETSI registered for the benefit of its Members and of the 3GPP Organizational Partners.

LTE™ is a Trade Mark of ETSI currently being registered

for the benefit of its Members and of the 3GPP Organizational Partners.

GSM® and the GSM logo are Trade Marks registered and owned by the GSM Association.

Intellectual Property Rights

IPRs essential or potentially essential to the present document may have been declared to ETSI. The information pertaining to these essential IPRs, if any, is publicly available for **ETSI members and non-members**, and can be found in ETSI SR 000 314: *"Intellectual Property Rights (IPRs); Essential, or potentially Essential, IPRs notified to ETSI in respect of ETSI standards"*, which is available from the ETSI Secretariat. Latest updates are available on the ETSI Web server (<http://webapp.etsi.org/IPR/home.asp>).

Pursuant to the ETSI IPR Policy, no investigation, including IPR searches, has been carried out by ETSI. No guarantee can be given as to the existence of other IPRs not referenced in ETSI SR 000 314 (or the updates on the ETSI Web server) which are, or may be, or may become, essential to the present document.

Foreword

This Technical Specification (TS) has been produced by ETSI 3rd Generation Partnership Project (3GPP).

The present document may refer to technical specifications or reports using their 3GPP identities, UMTS identities or GSM identities. These should be interpreted as being references to the corresponding ETSI deliverables.

The cross reference between GSM, UMTS, 3GPP and ETSI identities can be found under <http://webapp.etsi.org/key/queryform.asp>.

Contents

Intellectual Property Rights	2
Foreword.....	2
Foreword.....	4
1 Scope	5
2 References	5
3 Definitions and abbreviations.....	6
3.1 Definitions	6
3.2 Abbreviations	6
4 Data Link Layer	6
5 Circuit switched domain.....	6
5.1 Transport Network User Plane without bandwidth efficiency mechanisms	6
5.3 Transport Network User Plane with bandwidth efficiency mechanisms	6
5.3.1 General.....	6
5.3.2 Transport format	7
5.3.2.1 UDP.....	7
5.3.2.2 RTP	7
5.3.2.2.1 Transport Format for multiplexing RTP packets	7
6 Packet switched domain	9
6.1 Transport network user plane	9
Annex A (informative): Change history	10
History	11

Foreword

This Technical Specification (TS) has been produced by the 3rd Generation Partnership Project (3GPP).

The contents of the present document are subject to continuing work within the TSG and may change following formal TSG approval. Should the TSG modify the contents of the present document, it will be re-released by the TSG with an identifying change of release date and an increase in version number as follows:

Version x.y.z

where:

- x the first digit:
 - 1 presented to TSG for information;
 - 2 presented to TSG for approval;
 - 3 or greater indicates TSG approved document under change control.
- y the second digit is incremented for all changes of substance, i.e. technical enhancements, corrections, updates, etc.
- z the third digit is incremented when editorial only changes have been incorporated in the document.

1 Scope

The present document specifies the standards for user data transport protocols between the HNB and HNB-GW/CN.

2 References

The following documents contain provisions which, through reference in this text, constitute provisions of the present document.

- References are either specific (identified by date of publication, edition number, version number, etc.) or non-specific.
- For a specific reference, subsequent revisions do not apply.
- For a non-specific reference, the latest version applies. In the case of a reference to a 3GPP document (including a GSM document), a non-specific reference implicitly refers to the latest version of that document *in the same Release as the present document*.

- [1] 3GPP TS 25.401: "UTRAN Overall Description".
- [2] 3GPP TS 25.467: "UTRAN architecture for 3G Home Node B (HNB); Stage 2".
- [3] 3GPP TS 25.415: "UTRAN Iu interface user plane protocols".
- [4] 3GPP TS 25.414: " UTRAN Iu interface data transport and transport signalling".
- [5] 3GPP TS 29.060: "General Packet Radio Service (GPRS); GPRS Tunnelling Protocol (GTP) across the Gn and Gp interface ".
- [6] IETF RFC 791 (September 1981): "Internet Protocol".
- [7] IETF RFC 2460 (December 1998): "Internet Protocol, Version 6 (IPv6) Specification".
- [8] IETF RFC 768 (August 1980): "User Datagram Protocol".
- [9] IETF RFC 1889 (January 1996): "RTP: A Transport Protocol for Real-Time Applications".
- [10] IETF RFC 1890 (January 1996): "RTP Profile for Audio and Video Conferences with Minimal Control".
- [11] 3GPP TS 25.469: "UTRAN Iuh interface Home Node B (HNB) Application Part (HNBAP) signalling".
- [12] 3GPP TR 21.905: "Vocabulary for 3GPP Specifications".

3 Definitions and abbreviations

3.1 Definitions

For the purposes of the present document, the terms and definitions given in TR 21.905 [12] and the following apply. A term defined in the present document takes precedence over the definition of the same term, if any, in TR 21.905 [12].

3.2 Abbreviations

For the purposes of the present document, the abbreviations given in TR 21.905 [1] and the following apply. An abbreviation defined in the present document takes precedence over the definition of the same abbreviation, if any, in TR 21.905 [1].

CN	Core Network
CS	Circuit Switched
HNB	Home Node B
HNB-GW	Home Node B Gateway
IP	Internet Protocol
IPv4	Internet Protocol version 4
IPv6	Internet Protocol version 6
PS	Packet Switched
RFC	Request For Comment
RTP	Real-Time Transport Protocol
UDP	User Datagram Protocol

4 Data Link Layer

Any data link protocol that fulfils the requirements toward the upper layer may be used.

5 Circuit switched domain

5.1 Transport Network User Plane without bandwidth efficiency mechanisms

Defined in Reference [4], Paragraph 5.1.3.

NOTE: The Transport Network Layer as described in ref [4] Paragraph 5.1.3, may be directly between HNB and the CN.

5.3 Transport Network User Plane with bandwidth efficiency mechanisms

5.3.1 General

Bandwidth efficient transport of Uplink CS data payload PDUs may be supported over bearer transport mechanisms for the Iuh interface, using a bearer transport multiplexing scheme that allows transporting several RTP PDUs of different user plane connections within one packet.

5.3.2 Transport format

UDP/IP shall be applied on Iuh between HNB and HNB GW as described in [4] for Iu between RNC and CN, paragraph 5.1.3, except as stated below.

5.3.2.1 UDP

The path protocol used shall be UDP [8]. If multiplexing is applied the source UDP port number shall indicate the local termination used to combine the multiplexed packet and the destination UDP port number shall indicate the remote port number where PDUs are demultiplexed.

5.3.2.2 RTP

RTP shall be applied as described in [4], paragraph 5.1.3.3 and requirements below.

5.3.2.2.1 Transport Format for multiplexing RTP packets

Use of multiplexing shall be negotiated between the HNB and HNB-GW.

Before each multiplexed RTP/codecs payload PDU inserted into the UDP/IP packet a Multiplex Header, which identifies the multiplexed packet, shall be inserted.

Bits								Number of Octets	
7	6	5	4	3	2	1	0		
Source IP, Dest IP, ...								20/40	IP
Source Port, Dest Port=<MUX UDP port>, Length, ...								8	UDP
T=0	Mux ID = (Destination UDP Port of multiplexed PDU) / 2							2	Multiplex Header
Length Indicator (LI) = n								1	
R	Source ID = (Source UDP Port of multiplexed PDU) / 2							2	
Full RTP packet								n	RTP header
									RTP Payload
Multiplex Header								5	Multiplex Header
Full RTP packet								m	RTP header
									RTP Payload
...									

Figure 1: UDP/IP Packet with multiplexed RTP payload PDUs

The Multiplex Header includes :

- T bit.

The field has two possible values. Value 0 shall be used for an uncompressed RTP header, as described in the present sub-clause. Value 1 is FFS.

- Mux ID, 15 bits.

For identification of different user plane connections. The value shall be the UDP destination port of the corresponding non-multiplexed RTP PDU packet divided by two (only even numbered ports are used for RTP sessions).

- Length Indicator (LI), 8 bits, unsigned integer.

Gives the length of the multiplexed RTP PDU packet (RTP header + RTP) in bytes (the last byte of the RTP PDU is padded to the next byte boundary if necessary). Maximum length is 255 bytes. This LI allows to calculate where the next Multiplex Header for the next multiplexed RTP PDU packet starts.

- R bit.

Reserved for future use. Shall be set to 0 by the sending entity and be ignored by the receiving entity.

- Source ID, 15 bits.

For identification of the different connections. The value shall be the source UDP port of the corresponding non-multiplexed RTP/codecs PDU packet divided by two (only even numbered ports are used for RTP sessions).

The multiplexed RTP PDU shall be inserted in the IP/UDP packet directly after the corresponding Multiplex Header. The multiplexed RTP packet PDU shall follow the rules defined in [9] and consists of the full RTP header and the RTP payload. If the multiplexed RTP packet PDU does not end at a byte boundary, then the remaining bits of its last byte shall be padded with zeros.

The multiplexing method does not limit the number of packets being multiplexed and it is thus the data link layer protocol that defines the maximum frame size. In order to avoid additional delay in the network the packets should not be delayed more than 1 ms to 2 ms, which also effectively limits the number of multiplexed packets and makes the multiplexing-jitter low.

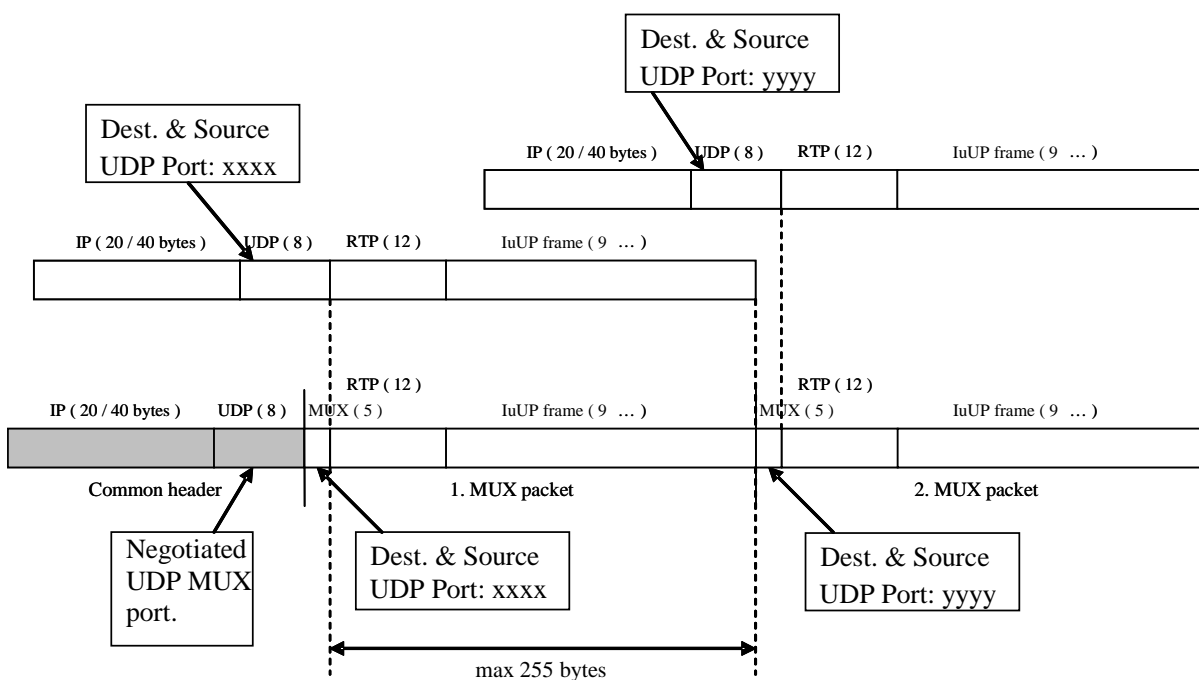

Figure 2: Example of multiplexed packet with two RTP frames

6 Packet switched domain

6.1 Transport network user plane

Defined in Ref [4] Paragraph 6.1.3.

NOTE: The Transport Network Layer as described in ref [4] paragraph 6.1.3, may be directly between HNB and the CN.

Annex A (informative): Change history

TSG #	TSG Doc.	CR	Rev	Subject/Comment	New
				Initial Skeleton	0.1.0
				Addition of TP for signalling for bandwidth efficiency	0.2.0
				Presented for approval at RAN#46	2.0.0
46	RP-091104			Approved at RAN#46	9.0.0
				Editorial clean up	9.0.1
				Version number in the change history corrected	9.0.2

History

Document history		
V9.0.2	February 2010	Publication