

ETSI TS 125 434 V7.2.0 (2008-01)

Technical Specification

**Universal Mobile Telecommunications System (UMTS);
UTRAN Iub interface data transport and transport signalling
for Common Transport Channel data streams
(3GPP TS 25.434 version 7.2.0 Release 7)**



ReferenceRTS/TSGR-0325434v720

KeywordsUMTS

ETSI

650 Route des Lucioles
F-06921 Sophia Antipolis Cedex - FRANCE

Tel.: +33 4 92 94 42 00 Fax: +33 4 93 65 47 16

Siret N° 348 623 562 00017 - NAF 742 C
Association à but non lucratif enregistrée à la
Sous-Préfecture de Grasse (06) N° 7803/88

Important notice

Individual copies of the present document can be downloaded from:

<http://www.etsi.org>

The present document may be made available in more than one electronic version or in print. In any case of existing or perceived difference in contents between such versions, the reference version is the Portable Document Format (PDF). In case of dispute, the reference shall be the printing on ETSI printers of the PDF version kept on a specific network drive within ETSI Secretariat.

Users of the present document should be aware that the document may be subject to revision or change of status. Information on the current status of this and other ETSI documents is available at

<http://portal.etsi.org/tb/status/status.asp>

If you find errors in the present document, please send your comment to one of the following services:

http://portal.etsi.org/chaicor/ETSI_support.asp

Copyright Notification

No part may be reproduced except as authorized by written permission.
The copyright and the foregoing restriction extend to reproduction in all media.

© European Telecommunications Standards Institute 2008.
All rights reserved.

DECTTM, **PLUGTESTS**TM, **UMTS**TM, **TIPHON**TM, the TIPHON logo and the ETSI logo are Trade Marks of ETSI registered for the benefit of its Members.

3GPPTM is a Trade Mark of ETSI registered for the benefit of its Members and of the 3GPP Organizational Partners.

Intellectual Property Rights

IPRs essential or potentially essential to the present document may have been declared to ETSI. The information pertaining to these essential IPRs, if any, is publicly available for **ETSI members and non-members**, and can be found in ETSI SR 000 314: "*Intellectual Property Rights (IPRs); Essential, or potentially Essential, IPRs notified to ETSI in respect of ETSI standards*", which is available from the ETSI Secretariat. Latest updates are available on the ETSI Web server (<http://webapp.etsi.org/IPR/home.asp>).

Pursuant to the ETSI IPR Policy, no investigation, including IPR searches, has been carried out by ETSI. No guarantee can be given as to the existence of other IPRs not referenced in ETSI SR 000 314 (or the updates on the ETSI Web server) which are, or may be, or may become, essential to the present document.

Foreword

This Technical Specification (TS) has been produced by ETSI 3rd Generation Partnership Project (3GPP).

The present document may refer to technical specifications or reports using their 3GPP identities, UMTS identities or GSM identities. These should be interpreted as being references to the corresponding ETSI deliverables.

The cross reference between GSM, UMTS, 3GPP and ETSI identities can be found under <http://webapp.etsi.org/key/queryform.asp>.

Contents

Intellectual Property Rights	2
Foreword.....	2
Foreword.....	4
1 Scope	5
2 References	5
3 Definitions, symbols and abbreviations	6
3.1 Definitions	6
3.2 Symbols.....	6
3.3 Abbreviations	6
3.4 Specification Notations	7
4 Data Link Layer	8
4.1 ATM Transport Option	8
4.1.1 Protection Switching at ATM Layer	8
4.2 Data Link Layer for IP Transport Option.....	8
5 I _{ub} Data Transport for Common Transport Channel Data Streams	8
5.1 Introduction	8
5.2 ATM Transport Option	9
5.3 IP Transport Option.....	9
6 I _{ub} Transport Signalling Application for Common Transport Channel Data Streams.....	10
6.1 Introduction	10
6.2 Transport Signalling in case of ATM Transport Option.....	10
6.3 Transport Signalling in case of IP Transport Option.....	10
7 Signalling Bearer for ALCAP on I _{ub} Interface	10
7.1 Introduction	10
7.2 Signalling Bearer in ATM Transport Option	10
7.3 Signalling Bearer in IP Transport Option.....	11
8 Interworking between ATM and IP Transport Options	11
Annex A (informative): Change history	12
History	13

Foreword

This Technical Specification (TS) has been produced by the 3rd Generation Partnership Project (3GPP).

The contents of the present document are subject to continuing work within the TSG and may change following formal TSG approval. Should the TSG modify the contents of the present document, it will be re-released by the TSG with an identifying change of release date and an increase in version number as follows:

Version x.y.z

where:

- x the first digit:
 - 1 presented to TSG for information;
 - 2 presented to TSG for approval;
 - 3 or greater indicates TSG approved document under change control.
- y the second digit is incremented for all changes of substance, i.e. technical enhancements, corrections, updates, etc.
- z the third digit is incremented when editorial only changes have been incorporated in the document.

1 Scope

The present document shall provide a specification of the UTRAN RNC-Node B (Iub) interface Data Transport and Transport Signalling for Common Transport Channel data streams.

2 References

The following documents contain provisions which, through reference in this text, constitute provisions of the present document.

- References are either specific (identified by date of publication, edition number, version number, etc.) or non-specific.
- For a specific reference, subsequent revisions do not apply.
- For a non-specific reference, the latest version applies. In the case of a reference to a 3GPP document (including a GSM document), a non-specific reference implicitly refers to the latest version of that document *in the same Release as the present document*.

- [1] ITU-T Recommendation I.363.2 (11/2000): "B-ISDN ATM Adaptation layer specification: Type 2 AAL".
- [2] ITU-T Recommendation I.366.1 (6/98): "Segmentation and Reassembly Service Specific Convergence Sublayer for the AAL type 2".
- [3] ITU-T Recommendation Q.2630.1 (12/99): "AAL type 2 signalling protocol (Capability Set 1)".
- [4] ITU-T Recommendation Q.2110 (7/94): "B-ISDN ATM adaptation layer - Service Specific Connection Oriented Protocol (SSCOP)".
- [5] ITU-T Recommendation Q.2130 (7/94): "B-ISDN signalling ATM adaptation Layer - Service Specific Coordination Function for Support of Signalling at the User Network Interface (SSCF at UNI)".
- [6] ITU-T Recommendation Q.2150.2 (12/99): "Signalling transport converter on SSCOP and SSCOPMCE".
- [7] ITU-T Recommendation I.361 (11/95): "B-ISDN ATM layer specification".
- [8] ITU-T Recommendation I.630 (2/99): "ATM protection switching".
- [9] ITU-T Recommendation Q.2630.2 (12/2000): "AAL Type 2 signalling protocol (Capability Set 2)".
- [10] ITU-T Recommendation E.191 (03/00): "B-ISDN addressing".
- [11] ITU-T Recommendation X.213 (11/95): "Information Technology - Open Systems Interconnection - Network Service Definition".
- [12] IETF RFC 768, (August 1980): "User Datagram Protocol".
- [13] IETF RFC 2460, (December 1998): "Internet Protocol, Version 6 (IPv6) Specification".
- [14] IETF RFC 791, (September 1981): "Internet Protocol".
- [15] IETF RFC 2474, (December 1998): "Definition of the Differentiated Services Field (DS Field) in the IPv4 and IPv6 Headers".
- [16] IETF RFC 1661, (July 1994): "The Point-to-Point Protocol (PPP)".
- [17] IETF RFC 1662, (July 1994): "PPP in HDLC-like Framing".

- [18] IETF RFC 2507, (February 1999): "IP header compression".
- [19] IETF RFC 1990, (August 1996): "The PPP Multilink Protocol (MP)".
- [20] IETF RFC 2686, (September 1999): "The Multi-Class Extension to Multi-Link PPP".
- [21] IETF RFC 2509, (February 1999): "IP Header Compression over PPP".
- [22] 3GPP TS 25.401, "UTRAN Overall Description"
- [23] 3GPP TS 25.426, "UTRAN Iur and Iub Interface Data Transport & Transport Signalling for DCH Data Streams"
- [24] IETF RFC 3153, (August 2001): "PPP Multiplexing".
- [25] IETF RFC 2364, (July 1998): "PPP over AAL5".
- [26] IETF RFC 3031, (January 2001): "Multiprotocol Label Switching Architecture".
- [27] ITU-T Recommendation E.164 (5/97): " The international public telecommunication numbering plan ".
- [28] IETF RFC 3376 "Internet Group Management Protocol, Version 3".
- [29] IETF RFC 3810 "Multicast Listener Discovery Version 2 (MLDv2) for IPv6".

3 Definitions, symbols and abbreviations

For the purposes of the present document, the following abbreviations apply:

3.1 Definitions

For the purposes of the present document, the following terms and definitions apply.

ALCAP: "ALCAP" is a generic name for the transport signalling protocol used to setup and tear down transport bearers.

IP UTRAN node: An UTRAN Node supporting the IP Transport Option

3.2 Symbols

Void.

3.3 Abbreviations

AAL	ATM Adaption Layer
AAL2	AAL Type 2
ATM	Asynchronous Transfer Mode
CPCS	Common Part Convergence Sublayer
CPS	Common Part Sublayer
DSCH	Downlink Shared Channel
FACH	Forward Access Channel
FP	Frame Protocol
HDLC	High-level Data Link Control
HS-DSCH	High Speed Downlink Shared Channel
IP	Internet Protocol
LC	Link Characteristics
PPP	Point-to-Point Protocol
PT	Path Type
RACH	Random Access Channel

RNC	Radio Network Controller
SAAL	Signalling ATM Adaption Layer
SAR	Segmentation And Reassembly
SSCF	Service Specific Co-ordination Function
SSCOP	Service Specific Connection Oriented Protocol
SSCS	Service Specific Convergence Sublayer
SSSAR	Service Specific Segmentation And Reassembly
STC	Signalling Transport Converter
UDP	User Datagram Protocol
UMTS	Universal Mobile Telecommunication Network
UNI	User-Network Interface
USCH	Uplink Shared Channel
UTRAN	UMTS Terrestrial Radio Access Network

3.4 Specification Notations

For the purposes of the present document, the following notations apply:

- [FDD] This tagging of a word indicates that the word preceding the tag "[FDD]" applies only to FDD. This tagging of a heading indicates that the heading preceding the tag "[FDD]" and the section following the heading applies only to FDD.
- [TDD] This tagging of a word indicates that the word preceding the tag "[TDD]" applies only to TDD, including 3.84Mcps TDD, 7.68Mcps TDD and 1.28Mcps TDD. This tagging of a heading indicates that the heading preceding the tag "[TDD]" and the section following the heading applies only to TDD, including 3.84Mcps TDD, 7.68Mcps TDD and 1.28Mcps TDD.
- [3.84Mcps TDD] This tagging of a word indicates that the word preceding the tag "[3.84Mcps TDD]" applies only to 3.84Mcps TDD. This tagging of a heading indicates that the heading preceding the tag "[3.84Mcps TDD]" and the section following the heading applies only to 3.84Mcps TDD.
- [1.28Mcps TDD] This tagging of a word indicates that the word preceding the tag "[1.28Mcps TDD]" applies only to 1.28Mcps TDD. This tagging of a heading indicates that the heading preceding the tag "[1.28Mcps TDD]" and the section following the heading applies only to 1.28Mcps TDD.
- [7.68Mcps TDD] This tagging of a word indicates that the word preceding the tag "[7.68Mcps TDD]" applies only to 7.68Mcps TDD. This tagging of a heading indicates that the heading preceding the tag "[7.68Mcps TDD]" and the section following the heading applies only to 7.68Mcps TDD.
- [FDD - ...] This tagging indicates that the enclosed text following the "[FDD - " applies only to FDD. Multiple sequential paragraphs applying only to FDD are enclosed separately to enable insertion of TDD specific (or common) paragraphs between the FDD specific paragraphs.
- [TDD - ...] This tagging indicates that the enclosed text following the "[TDD - " applies only to TDD including 3.84Mcps TDD, 7.68Mcps TDD and 1.28Mcps TDD. Multiple sequential paragraphs applying only to TDD are enclosed separately to enable insertion of FDD specific (or common) paragraphs between the TDD specific paragraphs.
- [3.84Mcps TDD - ...] This tagging indicates that the enclosed text following the "[3.84Mcps TDD - " applies only to 3.84Mcps TDD. Multiple sequential paragraphs applying only to 3.84Mcps TDD are enclosed separately to enable insertion of FDD and TDD specific (or common) paragraphs between the 3.84Mcps TDD specific paragraphs.
- [1.28Mcps TDD - ...] This tagging indicates that the enclosed text following the "[1.28Mcps TDD - " applies only to 1.28Mcps TDD. Multiple sequential paragraphs applying only to 1.28Mcps TDD are enclosed separately to enable insertion of FDD and TDD specific (or common) paragraphs between the 1.28Mcps TDD specific paragraphs.

[7.68Mcps TDD - ...] This tagging indicates that the enclosed text following the "[7.68Mcps TDD - " applies only to 7.68Mcps TDD. Multiple sequential paragraphs applying only to 7.68Mcps TDD are enclosed separately to enable insertion of FDD and TDD specific (or common) paragraphs between the 7.68Mcps TDD specific paragraphs.

4 Data Link Layer

4.1 ATM Transport Option

ATM shall be used in the transport network user plane and the transport network control plane according to ITU-T Recommendation I.361 [7].

4.1.1 Protection Switching at ATM Layer

If redundancy of pathways at ATM layer between RNC and Node B is supported, it shall be implemented using ATM Protection Switching according to ITU-T Recommendation I.630 [8].

4.2 Data Link Layer for IP Transport Option

An RNC or Node B supporting IP Transport Option shall support the PPP protocol with HDLC framing [16], [17].

NOTE: This does not preclude the single implementation and use of any other L2/L1 protocols (e.g. PPPMux/AAL5/ATM [24][25], PPP/AAL2/ATM, Ethernet, MPLS/ATM [26], etc.) fulfilling the UTRAN requirements towards the upper layers.

An RNC or Node B supporting IP transport option and having interfaces connected via low bandwidth PPP links like E1/T1/J1 shall also support IP Header Compression [18] and the PPP extensions ML/MC-PPP [19], [20]. In this case, negotiation of header compression [18] over PPP shall be performed via [21].

5 I_{ub} Data Transport for Common Transport Channel Data Streams

5.1 Introduction

This subclause specifies the transport layers that support Common Transport Channel (FACH, RACH, PCH, DSCH, HS-DSCH, USCH [TDD]) data streams.

There are two options for protocol suites for transport of RACH, FACH, USCH [TDD], DSCH and HS-DSCH Iub data streams:

- 1) ATM Transport Option
- 2) IP Transport Option

The following figure 1 shows the protocol stacks of these two options:

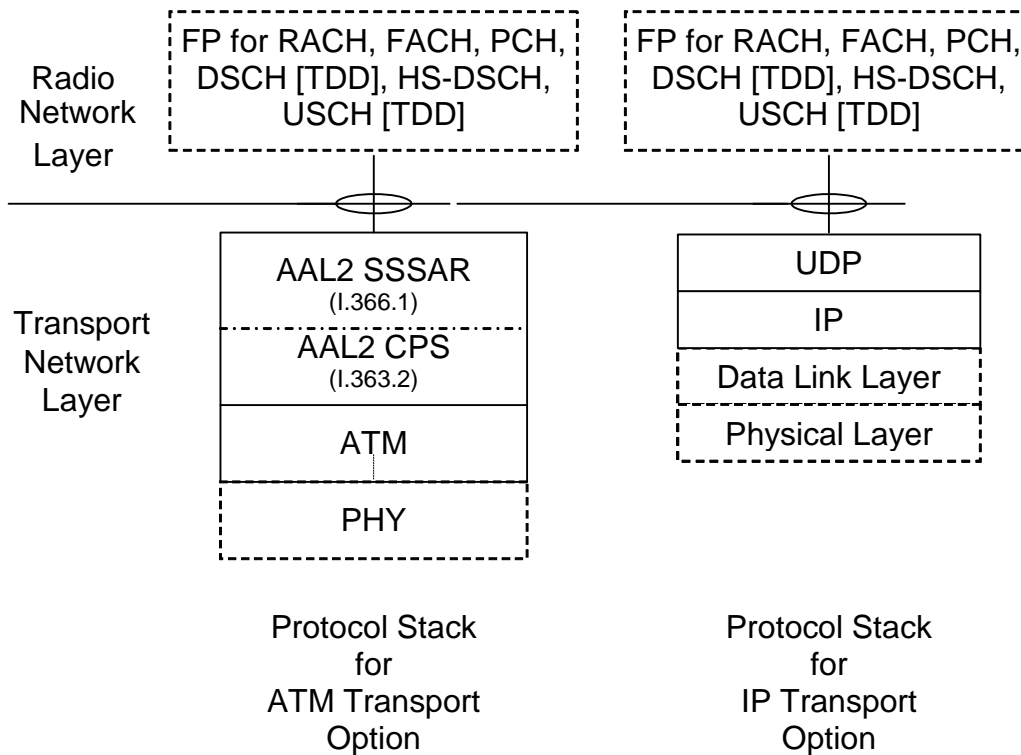

Figure 1: Protocol stack for the transport of RACH, FACH, PCH, DSCH [TDD], USCH [TDD] and HS-DSCH Iub data streams

5.2 ATM Transport Option

ATM and AAL2 (I.363.2 [1] and I.366.1 [2]) are used at the standard transport layer for Iub RACH, FACH, PCH, DSCH [TDD], USCH [TDD], HS-DSCH data streams.

The Service Specific Segmentation and Reassembly (SSSAR) sublayer is used for the segmentation and reassembly of AAL2 SDUs (i.e. SSSAR is only considered from ITU-T Recommendation I.366.1).

5.3 IP Transport Option

UDP [12] over IP shall be supported as the transport for RACH, FACH, PCH, DSCH [TDD], USCH [TDD] and HS-DSCH data streams on Iub Interface. The data link layer is as specified in chapter 4.2

An IP UTRAN node shall support IPv6 [13]. The support of IPv4 [14] is optional.

NOTE: This does not preclude single implementation and use of IPv4.

IP dual stack is recommended for the potential transition period from IPv4 to IPv6 in the transport network.

The transport bearer is identified by the UDP port number and the IP address (source UDP port number, destination UDP port number, source IP address, destination IP address).

The source IP address and destination IP address exchanged via Radio Network Layer on the Iur/Iub interface shall use the NSAP structure. See sub clause 6.1.8.2 of [22].

IP Differentiated Services code point marking [15] shall be supported. The mapping between traffic categories and Diffserv code points shall be configurable by O&M for each traffic category. Traffic categories are implementation-specific and may be determined from the application parameters.

IP multicast [28], [29] may be supported for FACH data streams on Iub Interface if the security of RAN will not be compromised. This can be guaranteed in a closed IP based RAN.

6 I_{ub} Transport Signalling Application for Common Transport Channel Data Streams

6.1 Introduction

This subclause specifies the transport signalling protocol(s) used to establish the user plane transport bearers. The protocol stack is shown in clause 7 (figure 2).

6.2 Transport Signalling in case of ATM Transport Option

Q.2630.2 as developed by ITU-T [9] is selected as the standard AAL2 signalling protocol for Iub. ITU-T Recommendation Q.2630.2 [9] adds new optional capabilities to ITU-T Recommendation Q.2630.1 [3].

Binding ID provided by the radio network layer shall be copied in SUGR parameter of ESTABLISH.request primitive of [9]. The binding identifier shall already be assigned and tied to a radio application procedure when the Establish Request message is received over the Iub interface in the Node B.

User Plane Transport bearers are established and in all normal cases released by the ALCAP in the Controlling RNC. The Node B shall initiate release of the user plane transport bearers for the removed common channels that were remaining within the cell when the cell is deleted.

AAL2 transport layer addressing is based on embedded E.164 or other AESA variants of the NSAP addressing format [10, 11]. Native E.164 addressing [27] shall not be used.

If there is an AAL2 switching function in the transport network layer of the interface, the Link Characteristics parameter (LC) shall be included in the Establish Request message and in the Modification Request message of AAL2 signalling protocol.

If there is an AAL2 switching function in the transport network layer of the interface, the Path Type parameter (PT) may be included in the Establish Request message of AAL2 signalling protocol for prioritisation at ATM level.

If the value in either the Maximum CPS-SDU Bit Rate or the Average CPS-SDU Bit Rate of the Link Characteristics (LC) in AAL2 signalling messages as specified in reference [9] is 2048 Kbit/s, it shall be interpreted as bit rate 2048 Kbit/s or higher.

NOTE: Separation of traffic (e.g. HSDPA) using this modified Q.2630.2 [9] from other traffic is highly recommended. Otherwise the bursty nature of the HSDPA traffic in combination with the unknown traffic volume per connection for bit rates exceeding 2048 Kbit/s may decrease the QoS of all traffic within the same AAL type 2 path.

6.3 Transport Signalling in case of IP Transport Option

An ALCAP protocol is not required in case both UTRAN Nodes (RNC and Node B) are using the IP Transport Option.

7 Signalling Bearer for ALCAP on I_{ub} Interface

7.1 Introduction

This subclause specifies the signalling bearer protocol stack which supports the ALCAP.

7.2 Signalling Bearer in ATM Transport Option

SAAL-UNI is the standard signalling bearer for the AAL Type Signalling protocol (Q.2630.2) on Iub [4, 5]. The protocol stack is shown in figure 2.

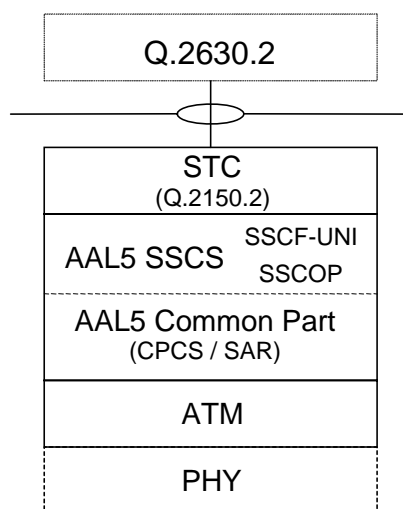

Figure 2: Transport Network Control plane protocol structure on Iub in case of ATM Transport Option

The signalling transport converter (STC) relevant for Iub is ITU-T Recommendation Q.2150.2 [6]. The AAL5 Common Part contains CPCS and SAR.

7.3 Signalling Bearer in IP Transport Option

An ALCAP protocol is not required in case of both UTRAN Nodes (RNC and Node B) are using the IP Transport Option.

8 Interworking between ATM and IP Transport Options

An RNC or Node B supporting IP transport option shall provide interworking to an RNC or Node B supporting only ATM transport option. The interworking alternatives are defined in [23].

Annex A (informative): Change history

Change history					
TSG RAN#	Version	CR	Tdoc RAN	New Version	Subject/Comment
RAN_04	-	-	-	3.0.0	Approved by TSG-RAN by correspondence
RAN_05	3.0.0	-	-	3.1.0	Approved by TSG-RAN #5
RAN_07	3.1.0	-	-	3.2.0	Approved at TSG RAN #7
RAN_09	3.2.0	003	RP-000390	3.3.0	Approved at TSG RAN #9
RAN_10	3.3.0	004 005	RP-000631	3.4.0	Approved at TSG RAN #10
RAN_11	3.4.0	006	RP-010127	3.5.0	Approved at TSG RAN #11

Change history							
Date	TSG #	TSG Doc.	CR	Rev	Subject/Comment	Old	New
March 01	11	RP-010163	007		Approved at TSG RAN #11 and placed under Change Control	-	4.0.0
March 01	11	RP-010162	008		Approved at TSG RAN #11 and placed under Change Control	-	4.0.0
06/2001	12	RP-010397	010		Approved at TSG RAN #12	4.0.0	4.1.0
12/2001	14	RP-010864	012		Reference corrections	4.1.0	4.2.0
12/2001	14	RP-010864	014	1	Missing PCH References	4.1.0	4.2.0
03/2002	15	RP-020175	020	1	Alignment of 25.434 to 25.426 and Correction to transport bearers release initiation	4.2.0	4.3.0
03/2002	15	RP-020189	021	5	Introduction of IP Transport Option in UTRAN	4.3.0	5.0.0
06/2002	16	RP-020413	024		Correction of Aesa formats	5.0.0	5.1.0
09/2003	21	RP-030538	027	3	Handling of maximum bit rate exceeding 2048kbit/s	5.1.0	5.2.0
12/2003	22	RP-030685	028	1	Diffserv marking is configurable	5.2.0	5.3.0
12/2003	22	-	-	-	Introduction of Release 6 specification	5.3.0	6.0.0
03/2004	23	RP-040061	030		Inclusion of HSDPA	6.0.0	6.1.0
06/2005	28	RP-050225	032		Feature Cleanup: Removal of CPCH	6.1.0	6.2.0
06/2005	28	RP-050232	034		Coding of IP address in RANAP, RNSAP and NBAP messages	6.1.0	6.2.0
06/2005	28	RP-050222	036		Feature clean-up: Removal of DSCH (FDD mode)	6.1.0	6.2.0
03/2006	31	-	-	-	Introduction of Release 7 specification	6.2.0	7.0.0
12/2006	34	RP-060837	038	1	Consistency of Specification Notations	7.0.0	7.1.0
12/2007	38	RP-070846	039	1	The Improvement of lub Efficiency for MBMS in IP RAN	7.1.0	7.2.0

History

Document history		
V7.0.0	March 2006	Publication
V7.1.0	December 2006	Publication
V7.2.0	January 2008	Publication