

ETSI TS 125 434 V3.8.0 (2002-06)

Technical Specification

**Universal Mobile Telecommunications System (UMTS);
UTRAN Iub interface data transport &
transport signalling for CCH data streams
(3GPP TS 25.434 version 3.8.0 Release 1999)**



Reference

RTS/TSGR-0325434v380

Keywords

UMTS

ETSI

650 Route des Lucioles
F-06921 Sophia Antipolis Cedex - FRANCE

Tel.: +33 4 92 94 42 00 Fax: +33 4 93 65 47 16

Siret N° 348 623 562 00017 - NAF 742 C
Association à but non lucratif enregistrée à la
Sous-Préfecture de Grasse (06) N° 7803/88

Important notice

Individual copies of the present document can be downloaded from:

<http://www.etsi.org>

The present document may be made available in more than one electronic version or in print. In any case of existing or perceived difference in contents between such versions, the reference version is the Portable Document Format (PDF). In case of dispute, the reference shall be the printing on ETSI printers of the PDF version kept on a specific network drive within ETSI Secretariat.

Users of the present document should be aware that the document may be subject to revision or change of status. Information on the current status of this and other ETSI documents is available at

<http://portal.etsi.org/tb/status/status.asp>

If you find errors in the present document, send your comment to:

editor@etsi.fr

Copyright Notification

No part may be reproduced except as authorized by written permission.
The copyright and the foregoing restriction extend to reproduction in all media.

© European Telecommunications Standards Institute 2002.
All rights reserved.

DECTTM, **PLUGTESTS**TM and **UMTS**TM are Trade Marks of ETSI registered for the benefit of its Members.
TIPHONTM and the **TIPHON logo** are Trade Marks currently being registered by ETSI for the benefit of its Members.
3GPPTM is a Trade Mark of ETSI registered for the benefit of its Members and of the 3GPP Organizational Partners.

Intellectual Property Rights

IPRs essential or potentially essential to the present document may have been declared to ETSI. The information pertaining to these essential IPRs, if any, is publicly available for **ETSI members and non-members**, and can be found in ETSI SR 000 314: "*Intellectual Property Rights (IPRs); Essential, or potentially Essential, IPRs notified to ETSI in respect of ETSI standards*", which is available from the ETSI Secretariat. Latest updates are available on the ETSI Web server (<http://webapp.etsi.org/IPR/home.asp>).

Pursuant to the ETSI IPR Policy, no investigation, including IPR searches, has been carried out by ETSI. No guarantee can be given as to the existence of other IPRs not referenced in ETSI SR 000 314 (or the updates on the ETSI Web server) which are, or may be, or may become, essential to the present document.

Foreword

This Technical Specification (TS) has been produced by ETSI 3rd Generation Partnership Project (3GPP).

The present document may refer to technical specifications or reports using their 3GPP identities, UMTS identities or GSM identities. These should be interpreted as being references to the corresponding ETSI deliverables.

The cross reference between GSM, UMTS, 3GPP and ETSI identities can be found under www.etsi.org/key.

Contents

Intellectual Property Rights	2
Foreword.....	2
Foreword.....	4
1 Scope	5
2 References	5
3 Definitions, symbols and abbreviations	5
3.1 Definitions	5
3.2 Symbols.....	6
3.3 Abbreviations	6
4 ATM Layer.....	6
4.1 General	6
4.2 Protection Switching at ATM Layer	6
5 I _{ub} Data Transport for Common Transport Channel Data Streams	6
5.1 Introduction	6
5.2 Transport Layer	7
6 I _{ub} Transport Signalling Application for Common Transport Channel Data Streams.....	7
6.1 Introduction	7
6.2 Transport Signalling	7
7 Signalling Bearer for ALCAP on I _{ub} Interface	8
7.1 Introduction	8
7.2 Signalling Bearer.....	8
Annex A (informative): Change history	9
History	10

Foreword

This Technical Specification (TS) has been produced by the 3rd Generation Partnership Project (3GPP).

The contents of the present document are subject to continuing work within the TSG and may change following formal TSG approval. Should the TSG modify the contents of the present document, it will be re-released by the TSG with an identifying change of release date and an increase in version number as follows:

Version x.y.z

where:

- x the first digit:
 - 1 presented to TSG for information;
 - 2 presented to TSG for approval;
 - 3 or greater indicates TSG approved document under change control.
- y the second digit is incremented for all changes of substance, i.e. technical enhancements, corrections, updates, etc.
- z the third digit is incremented when editorial only changes have been incorporated in the document.

1 Scope

The present document shall provide a specification of the UTRAN RNC-Node B (Iub) interface Data Transport and Transport Signalling for Common Transport Channel data streams.

2 References

The following documents contain provisions which, through reference in this text, constitute provisions of the present document.

- References are either specific (identified by date of publication, edition number, version number, etc.) or non-specific.
- For a specific reference, subsequent revisions do not apply.
- For a non-specific reference, the latest version applies. In the case of a reference to a 3GPP document (including a GSM document), a non-specific reference implicitly refers to the latest version of that document *in the same Release as the present document*.

- [1] ITU-T Recommendation I.363.2 (9/97): "B-ISDN ATM Adaptation layer specification: Type 2 AAL".
- [2] ITU-T Recommendation I.366.1 (6/98): "Segmentation and Reassembly Service Specific Convergence Sublayer for the AAL type 2".
- [3] ITU-T Recommendation Q.2630.1 (12/99): "AAL type 2 signalling protocol (Capability Set 1)".
- [4] ITU-T Recommendation Q.2110 (7/94): "B-ISDN ATM adaptation layer - Service Specific Connection Oriented Protocol (SSCOP)".
- [5] ITU-T Recommendation Q.2130 (7/94): "B-ISDN signalling ATM adaptation layer - Service Specific Coordination Function for Support of Signalling at the User Network Interface (SSCF at UNI)".
- [6] ITU-T Recommendation Q.2150.2 (12/99): "Signalling Transport Converter on SSCOP and SSCOPMCE".
- [7] ITU-T Recommendation I.361 (11/95): "B-ISDN ATM layer specification".
- [8] ITU-T Recommendation I.630 (2/99): "ATM protection switching".
- [9] ITU-T Recommendation E.191 (03/00): "B-ISDN addressing".
- [10] ITU-T Recommendation X.213 (11/95): "Information Technology - Open Systems Interconnection - Network Service Definition".
- [11] ITU-T Recommendation E.164 (5/97): "The international public telecommunication numbering plan".

3 Definitions, symbols and abbreviations

For the purposes of the present document, the following abbreviations apply:

3.1 Definitions

Void.

3.2 Symbols

Void.

3.3 Abbreviations

AAL	ATM Adaption Layer
AAL2	AAL Type 2
ATM	Asynchronous Transfer Mode
CPCH	Common Packet Channel
CPCS	Common Part Convergence Sublayer
CPS	Common Part Sublayer
DSCH	Downlink Shared Channel
FACH	Forward Access Channel
FP	Frame Protocol
RACH	Random Access Channel
RNC	Radio Network Controller
SAAL	Signalling ATM Adaption Layer
SAR	Segmentation And Reassembly
SSCF	Service Specific Co-ordination Function
SSCOP	Service Specific Connection Oriented Protocol
SSCS	Service Specific Convergence Sublayer
SSSAR	Service Specific Segmentation And Reassembly
STC	Signalling Transport Converter
UMTS	Universal Mobile Telecommunication Network
UNI	User-Network Interface
USCH	Uplink Shared Channel
UTRAN	UMTS Terrestrial Radio Access Network

4 ATM Layer

4.1 General

ATM shall be used in the transport network user plane and the transport network control plane according to ITU-T Recommendation I.361 [7].

4.2 Protection Switching at ATM Layer

If redundancy of pathways at ATM layer between RNC and Node B is supported, it shall be implemented using ATM Protection Switching according to ITU-T Recommendation I.630 [8].

5 I_{ub} Data Transport for Common Transport Channel Data Streams

5.1 Introduction

This subclause specifies the transport layers that support Common Transport Channel (FACH, RACH, CPCH [FDD], PCH, DSCH, USCH [TDD]) data streams.

5.2 Transport Layer

ATM and AAL2 (I.363.2 [1] and I.366.1 [2]) are used at the standard transport layer for Iub RACH, CPCH [FDD] FACH, PCH, DSCH, USCH [TDD] data streams.

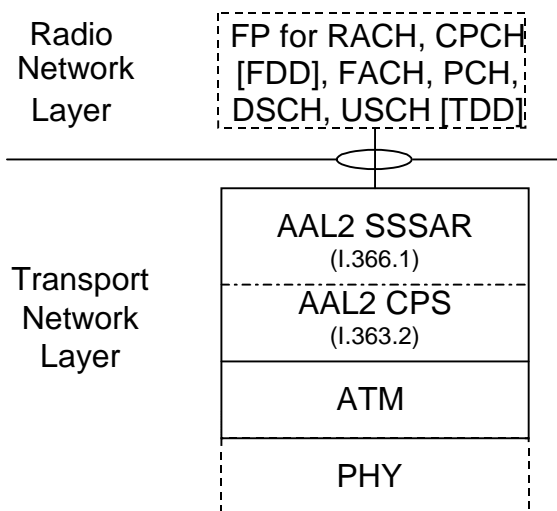

Figure 1: Protocol stack for RACH, CPCH [FDD], FACH, PCH, DSCH and USCH [TDD] Iub data stream transport

Figure 1 shows the protocol stack for the transport of RACH, CPCH [FDD], FACH, PCH, DSCH and USCH [TDD] Iub data streams. The Service Specific Segmentation and Reassembly (SSSAR) sublayer is used for the segmentation and reassembly of AAL2 SDUs (i.e. SSSAR is only considered from ITU-T Recommendation I.366.1).

6 I_{ub} Transport Signalling Application for Common Transport Channel Data Streams

6.1 Introduction

This subclause specifies the transport signalling protocol(s) used to establish the user plane transport bearers. The protocol stack is shown in clause 7 (figure 2).

6.2 Transport Signalling

Q.2630.1 [3] as developed by ITU-T is selected as the standard AAL2 signalling protocol for Iub.

Binding ID provided by the radio network layer shall be copied in SUGR parameter of ESTABLISH.request primitive of [3]. The binding identifier shall already be assigned and tied to a radio application procedure when the Establish Request message is received over the Iub interface in the Node B.

User Plane Transport bearers are established and in all normal cases released by the ALCAP in the Controlling RNC. The Node B shall initiate release of the user plane transport bearers for the removed common channels that were remaining within the cell when the cell is deleted.

AAL2 transport layer addressing is based on embedded E.164 or other AESA variants of the NSAP addressing format [9, 10]. Native E.164 addressing [11] shall not be used.

If there is an AAL2 switching function in the transport network layer of the interface, the AAL2 Link Characteristics parameter (ALC) shall be included in the Establish Request message of AAL2 signalling protocol.

7 Signalling Bearer for ALCAP on I_{ub} Interface

7.1 Introduction

This subclause specifies the signalling bearer protocol stack which supports ALCAP protocol.

7.2 Signalling Bearer

SAAL-UNI is the standard signalling bearer for the AAL Type Signalling protocol (Q.2630.1) on Iub [4, 5]. The protocol stack is shown in figure 2.

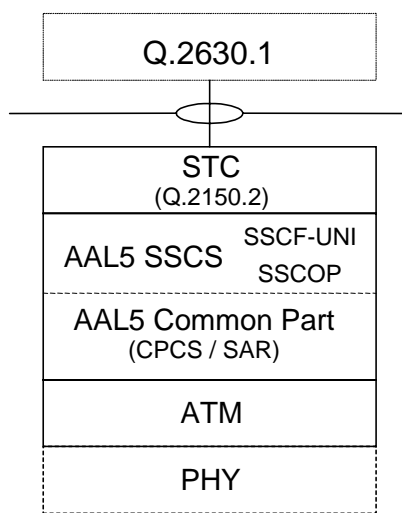

Figure 2: Transport Network Control plane protocol structure on Iub

The signalling transport converter (STC) relevant for Iub is Q.2150.2 [6]. The AAL5 Common Part contains CPCS and SAR.

Annex A (informative): Change history

Change history					
TSG RAN#	Version	CR	Tdoc RAN	New Version	Subject/Comment
RAN_04	-	-	-	3.0.0	Approved by TSG-RAN by correspondence
RAN_05	3.0.0	-	-	3.1.0	Approved by TSG-RAN #5
RAN_07	3.1.0	-	-	3.2.0	Approved at TSG RAN #7
RAN_09	3.2.0	003	RP-000390	3.3.0	Approved at TSG RAN #9
RAN_10	3.3.0	004 005	RP-000631	3.4.0	Approved at TSG RAN #10
RAN_11	3.4.0	006	RP-010127	3.5.0	Approved at TSG RAN #11
RAN 14	3.5.0	011	RP-010864	3.6.0	Reference corrections
RAN 14	3.5.0	013	RP-010864	3.6.0	Missing PCH References
RAN 15	3.6.0	019	RP-020175	3.7.0	Alignment of 25.434 to 25.426 and Correction to transport bearers release initiation
RAN 16	3.7.0	022	RP-02043	3.8.0	Correction of Aesa formats

History

Document history		
V3.1.0	January 2000	Publication
V3.2.0	March 2000	Publication
V3.3.0	September 2000	Publication
V3.4.0	December 2000	Publication
V3.5.0	March 2001	Publication
V3.6.0	December 2001	Publication
V3.7.0	March 2002	Publication
V3.8.0	June 2002	Publication