

ETSI TS 125 432 V17.0.0 (2022-04)



Universal Mobile Telecommunications System (UMTS); UTRAN Iub interface: signalling transport (3GPP TS 25.432 version 17.0.0 Release 17)



Reference

RTS/TSGR-0325432vh00

Keywords

UMTS

ETSI

650 Route des Lucioles
F-06921 Sophia Antipolis Cedex - FRANCE

Tel.: +33 4 92 94 42 00 Fax: +33 4 93 65 47 16

Siret N° 348 623 562 00017 - APE 7112B
Association à but non lucratif enregistrée à la
Sous-Préfecture de Grasse (06) N° w061004871

Important notice

The present document can be downloaded from:

<http://www.etsi.org/standards-search>

The present document may be made available in electronic versions and/or in print. The content of any electronic and/or print versions of the present document shall not be modified without the prior written authorization of ETSI. In case of any existing or perceived difference in contents between such versions and/or in print, the prevailing version of an ETSI deliverable is the one made publicly available in PDF format at www.etsi.org/deliver.

Users of the present document should be aware that the document may be subject to revision or change of status.

Information on the current status of this and other ETSI documents is available at

<https://portal.etsi.org/TB/ETSIDeliverableStatus.aspx>

If you find errors in the present document, please send your comment to one of the following services:

<https://portal.etsi.org/People/CommitteeSupportStaff.aspx>

If you find a security vulnerability in the present document, please report it through our
Coordinated Vulnerability Disclosure Program:

<https://www.etsi.org/standards/coordinated-vulnerability-disclosure>

Notice of disclaimer & limitation of liability

The information provided in the present deliverable is directed solely to professionals who have the appropriate degree of experience to understand and interpret its content in accordance with generally accepted engineering or other professional standard and applicable regulations.

No recommendation as to products and services or vendors is made or should be implied.

No representation or warranty is made that this deliverable is technically accurate or sufficient or conforms to any law and/or governmental rule and/or regulation and further, no representation or warranty is made of merchantability or fitness for any particular purpose or against infringement of intellectual property rights.

In no event shall ETSI be held liable for loss of profits or any other incidental or consequential damages.

Any software contained in this deliverable is provided "AS IS" with no warranties, express or implied, including but not limited to, the warranties of merchantability, fitness for a particular purpose and non-infringement of intellectual property rights and ETSI shall not be held liable in any event for any damages whatsoever (including, without limitation, damages for loss of profits, business interruption, loss of information, or any other pecuniary loss) arising out of or related to the use of or inability to use the software.

Copyright Notification

No part may be reproduced or utilized in any form or by any means, electronic or mechanical, including photocopying and microfilm except as authorized by written permission of ETSI.

The content of the PDF version shall not be modified without the written authorization of ETSI.

The copyright and the foregoing restriction extend to reproduction in all media.

© ETSI 2022.
All rights reserved.

Intellectual Property Rights

Essential patents

IPRs essential or potentially essential to normative deliverables may have been declared to ETSI. The declarations pertaining to these essential IPRs, if any, are publicly available for **ETSI members and non-members**, and can be found in ETSI SR 000 314: "*Intellectual Property Rights (IPRs); Essential, or potentially Essential, IPRs notified to ETSI in respect of ETSI standards*", which is available from the ETSI Secretariat. Latest updates are available on the ETSI Web server (<https://ipr.etsi.org/>).

Pursuant to the ETSI Directives including the ETSI IPR Policy, no investigation regarding the essentiality of IPRs, including IPR searches, has been carried out by ETSI. No guarantee can be given as to the existence of other IPRs not referenced in ETSI SR 000 314 (or the updates on the ETSI Web server) which are, or may be, or may become, essential to the present document.

Trademarks

The present document may include trademarks and/or tradenames which are asserted and/or registered by their owners. ETSI claims no ownership of these except for any which are indicated as being the property of ETSI, and conveys no right to use or reproduce any trademark and/or tradename. Mention of those trademarks in the present document does not constitute an endorsement by ETSI of products, services or organizations associated with those trademarks.

DECT™, **PLUGTESTS™**, **UMTS™** and the ETSI logo are trademarks of ETSI registered for the benefit of its Members. **3GPP™** and **LTE™** are trademarks of ETSI registered for the benefit of its Members and of the 3GPP Organizational Partners. **oneM2M™** logo is a trademark of ETSI registered for the benefit of its Members and of the oneM2M Partners. **GSM®** and the GSM logo are trademarks registered and owned by the GSM Association.

Legal Notice

This Technical Specification (TS) has been produced by ETSI 3rd Generation Partnership Project (3GPP).

The present document may refer to technical specifications or reports using their 3GPP identities. These shall be interpreted as being references to the corresponding ETSI deliverables.

The cross reference between 3GPP and ETSI identities can be found under <http://webapp.etsi.org/key/queryform.asp>.

Modal verbs terminology

In the present document "**shall**", "**shall not**", "**should**", "**should not**", "**may**", "**need not**", "**will**", "**will not**", "**can**" and "**cannot**" are to be interpreted as described in clause 3.2 of the [ETSI Drafting Rules](#) (Verbal forms for the expression of provisions).

"**must**" and "**must not**" are **NOT** allowed in ETSI deliverables except when used in direct citation.

Contents

Intellectual Property Rights	2
Legal Notice	2
Modal verbs terminology.....	2
Foreword.....	4
1 Scope	5
2 References	5
3 Definitions, symbols and abbreviations	6
3.1 Definitions	6
3.2 Symbols.....	6
3.3 Abbreviations	6
4 Data Link Layer	6
4.1 ATM Transport Option	6
4.1.1 Protection switching at ATM Layer	6
4.2 Data Link Layer for IP Transport Option.....	6
5 NBAP signalling bearer.....	7
5.1 Introduction	7
5.2 Signalling bearer in case of ATM Transport Option	7
5.3 Signalling bearer in case of IP Transport Option	7
Annex A (informative): Change history	9
History	10

Foreword

This Technical Specification has been produced by the 3rd Generation Partnership Project (3GPP).

The contents of the present document are subject to continuing work within the TSG and may change following formal TSG approval. Should the TSG modify the contents of the present document, it will be re-released by the TSG with an identifying change of release date and an increase in version number as follows:

Version x.y.z

where:

- x the first digit:
 - 1 presented to TSG for information;
 - 2 presented to TSG for approval;
 - 3 or greater indicates TSG approved document under change control.
- y the second digit is incremented for all changes of substance, i.e. technical enhancements, corrections, updates, etc.
- z the third digit is incremented when editorial only changes have been incorporated in the document.

1 Scope

The present document specifies the signalling transport related to NBAP signalling to be used across the Iub Interface. The Iub interface is a logical interface for the interconnection of Node B and Radio Network Controller (RNC) components of the UMTS Terrestrial Radio Access Network (UTRAN) for the UMTS system. The radio network control signalling between these nodes is based on the Node B application part (NBAP).

2 References

The following documents contain provisions which, through reference in this text, constitute provisions of the present document.

- References are either specific (identified by date of publication, edition number, version number, etc.) or non-specific.
- For a specific reference, subsequent revisions do not apply.
- For a non-specific reference, the latest version applies. In the case of a reference to a 3GPP document (including a GSM document), a non-specific reference implicitly refers to the latest version of that document *in the same Release as the present document*.

- [1] ITU-T Recommendation Q.2100 (1994-07): "B-ISDN signalling ATM adaptation layer (SAAL) overview description".
- [2] ITU-T Recommendation Q.2130 (1994-07): "B-ISDN signalling ATM adaptation layer – Service specific coordination function for support of signalling at the user network interface (SSCF–UNI)".
- [3] ITU-T Recommendation Q.2110 (1994-07): "B-ISDN ATM adaptation layer – Service specific connection oriented protocol (SSCOP)".
- [4] ITU-T Recommendation I.363.5 (1996-08): "B-ISDN ATM Adaptation Layer Specification : Type 5 AAL".
- [5] ITU-T Recommendation I.361 (1995-11): "B-ISDN ATM layer specification".
- [6] ITU-T Recommendation I.630 (1999-02): "ATM protection switching".
- [7] IETF RFC 2960 (2000-10): "Stream Control Transmission Protocol".
- [8] IETF RFC 2460 (1998-12): "Internet Protocol, Version 6 (IPv6) Specification".
- [9] IETF RFC 791 (1981-09): "Internet Protocol".
- [10] IETF RFC 2474 (1998-12): "Definition of the Differentiated Services Field (DS Field) in the IPv4 and IPv6 Headers".
- [11] IETF RFC 1661 (1994-07): "The Point-to-Point Protocol (PPP)".
- [12] IETF RFC 1662 (1994-07): "PPP in HDLC-like Framing".
- [13] IETF RFC 2507 (1999-02): "IP header compression".
- [14] IETF RFC 1990 (1996-08): "The PPP Multilink Protocol (MP)".
- [15] IETF RFC 2686 (1999-09): "The Multi-Class Extension to Multi-Link PPP".
- [16] IETF RFC 2509 (1999-02): "IP Header Compression over PPP".
- [17] IETF RFC 3153 (2001-08): "PPP Multiplexing".
- [18] IETF RFC 2364 (1998-07): "PPP over AAL5".
- [19] IETF RFC 3031 (2001-01): "Multiprotocol Label Switching Architecture".

- [20] IETF RFC 3309 (2002-09): "Stream Control Transmission Protocol (SCTP) Checksum Change".
- [21] 3GPP TS 25.433: "UTRAN Iub interface Node B Application Part (NBAP) signalling".

3 Definitions, symbols and abbreviations

3.1 Definitions

For the purposes of the present document, the following terms and definitions apply:

IP UTRAN node: An UTRAN Node supporting the IP Transport Option

3.2 Symbols

(void)

3.3 Abbreviations

AAL	ATM Adaptation Layer
ATM	Asynchronous Transfer Mode
HDLC	High-level Data Link Control
IP	Internet Protocol
NBAP	Node B Application Part
PPP	Point-to-Point Protocol
RNC	Radio Network Controller
SAAL	Signalling ATM Adaptation Layer
SCTP	Stream Control Transmission Protocol
SSCF	Service Specific Coordination Function
SSCOP	Service Specific Connection Oriented Protocol
UNI	User-Network Interface

4 Data Link Layer

4.1 ATM Transport Option

ATM shall be used in the radio network control plane according to ITU-T Rec. I.361 [5].

4.1.1 Protection switching at ATM Layer

If redundancy of pathways at ATM layer between RNC and Node B is supported, it shall be implemented using ATM Protection Switching according to ITU-T Rec. I.630 [6].

4.2 Data Link Layer for IP Transport Option

A RNC or Node B supporting IP Transport Option shall support the PPP protocol with HDLC framing (IETF RFC 1661 [11], IETF RFC 1662 [12]).

NOTE: This does not preclude the single implementation and use of any other L2/L1 protocols (e.g. PPPMux/AAL5/ATM (IETF RFC 3153 [17], IETF RFC 2364 [18]), PPP/AAL2/ATM, Ethernet, MPLS/ATM (IETF RFC 3031 [19]), etc.) fulfilling the UTRAN requirements towards the upper layers.

A RNC or Node B supporting IP transport option and having interfaces connected via slow bandwidth PPP links like E1/T1/J1 shall also support IP Header Compression (IETF RFC 2507 [13]) and the PPP extensions ML/MC-PPP (IETF

RFC 1990 [14], IETF RFC 2686 [15]). In this case, negotiation of header compression (IETF RFC 2507 [13]) over PPP shall be performed via (IETF RFC 2509 [16]).

5 NBAP signalling bearer

5.1 Introduction

The Signalling Bearer for NBAP (TS 25.433 [21]) is a point-to-point protocol. There may be multiple point-to-point links between an RNC and a Node B. As shown in figure 1, the standard allows operators to choose one out of two protocol suites for transporting the NBAP messages.

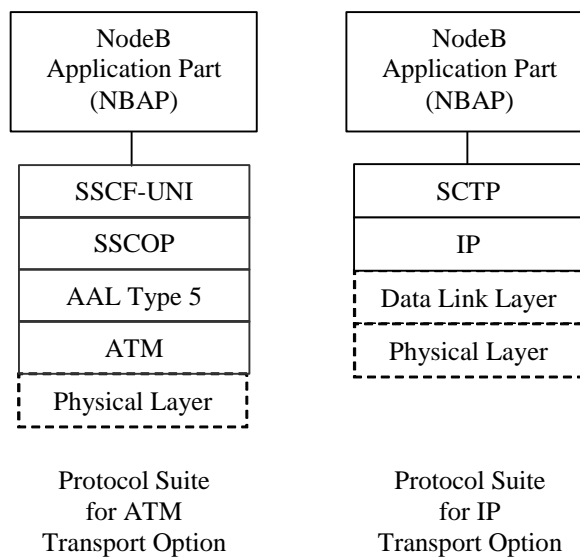

Figure 1: Iub NBAP Signalling Transport

5.2 Signalling bearer in case of ATM Transport Option

The signalling bearer in the Radio Network Control Plane is SAAL-UNI (ITU-T Rec. Q.2100 [1]) over ATM. The protocols to be used to support NBAP signalling are SSCF-UNI (ITU-T Rec. Q.2130 [2]) on top of SSCOP (ITU-T Rec. Q.2110 [3]) and AAL Type 5 (ITU-T Rec. I.363.5 [4]).

5.3 Signalling bearer in case of IP Transport Option

SCTP (IETF RFC 2960 [7]) over IP shall be supported as the transport for NBAP signalling bearer on Iub Interface. A RNC equipped with the SCTP stack option shall initiate the INIT procedure for establishing association. The data link layer is as specified in chapter 4.2.

The checksum method specified in IETF RFC 3309 [20] shall be used instead of the method specified in IETF RFC 2960 ([7]).

An IP UTRAN node shall support IPv6 (IETF RFC 2460 [8]). The support of IPv4 (IETF RFC 791 [9]) is optional.

NOTE: This does not preclude single implementation and use of IPv4.

IP dual stack is recommended for the potential transition period from IPv4 to IPv6 in the transport network.

Each signalling bearer between the RNC and Node B shall correspond to one single SCTP stream in UL and one single SCTP stream in DL direction, both streams belonging to the same SCTP association.

IP Differentiated Services code point marking (IETF RFC 2474 [10]) shall be supported. The Diffserv code point may be determined from the application parameters.

Annex A (informative): Change history

Date / TSG	TSG Doc.	CR	Rev	Subject/Comment	New
12/2008	-	-	-	Creation of Rel-8 version based on v7.1.0	8.0.0
12/2009	-	-	-	Creation of Rel-9 version based on v8.0.0	9.0.0
SP-49	SP-100629			Clarification on the use of References (TS 21.801 CR#0030)	9.0.1
03/2011				Creation of Rel-10 version based on v9.0.1	10.0.0
52	RP-110685	0008	1	Correction to the References	10.1.0
09/2012				Update to Rel-11 version (MCC)	11.0.0
09/2014				Update to Rel-12 version (MCC)	12.0.0
12/2015				Update to Rel-13 version (MCC)	13.0.0

Change history							
Date	Meeting	TDoc	CR	Rev	Cat	Subject/Comment	New version
2017-03	SA#75					Promotion to Release 14 without technical change	14.0.0
2018-07	SA#80	-	-	-	-	Promotion to Release 15 without technical change	15.0.0
2020-07	SA#88-e	-	-	-	-	Update to Rel-16 version (MCC)	16.0.0
2022-03	SA#95-e					Promotion to Release 17 without technical change	17.0.0

History

Document history		
V17.0.0	April 2022	Publication