

ETSI TS 125 430 V3.0.0 (2000-01)

Technical Specification

Universal Mobile Telecommunications System (UMTS); UTRAN I_{ub} Interface: General Aspects and Principles (3G TS 25.430 version 3.0.0 Release 1999)



Reference

DTS/TSGR-0325430U

Keywords

UMTS

ETSI

Postal address

F-06921 Sophia Antipolis Cedex - FRANCE

Office address

650 Route des Lucioles - Sophia Antipolis
Valbonne - FRANCE
Tel.: +33 4 92 94 42 00 Fax: +33 4 93 65 47 16
Siret N° 348 623 562 00017 - NAF 742 C
Association à but non lucratif enregistrée à la
Sous-Préfecture de Grasse (06) N° 7803/88

Internet

secretariat@etsi.fr
Individual copies of this ETSI deliverable
can be downloaded from
<http://www.etsi.org>
If you find errors in the present document, send your
comment to: editor@etsi.fr

Important notice

This ETSI deliverable may be made available in more than one electronic version or in print. In any case of existing or perceived difference in contents between such versions, the reference version is the Portable Document Format (PDF). In case of dispute, the reference shall be the printing on ETSI printers of the PDF version kept on a specific network drive within ETSI Secretariat.

Copyright Notification

No part may be reproduced except as authorized by written permission.
The copyright and the foregoing restriction extend to reproduction in all media.

© European Telecommunications Standards Institute 2000.
All rights reserved.

Intellectual Property Rights

IPRs essential or potentially essential to the present document may have been declared to ETSI. The information pertaining to these essential IPRs, if any, is publicly available for **ETSI members and non-members**, and can be found in SR 000 314: "*Intellectual Property Rights (IPRs); Essential, or potentially Essential, IPRs notified to ETSI in respect of ETSI standards*", which is available from the ETSI Secretariat. Latest updates are available on the ETSI Web server (<http://www.etsi.org/ipr>).

Pursuant to the ETSI IPR Policy, no investigation, including IPR searches, has been carried out by ETSI. No guarantee can be given as to the existence of other IPRs not referenced in SR 000 314 (or the updates on the ETSI Web server) which are, or may be, or may become, essential to the present document.

Foreword

This Technical Specification (TS) has been produced by the ETSI 3rd Generation Partnership Project (3GPP).

The present document may refer to technical specifications or reports using their 3GPP identities or GSM identities. These should be interpreted as being references to the corresponding ETSI deliverables. The mapping of document identities is as follows:

For 3GPP documents:

3G TS | TR nn.nnn "<title>" (with or without the prefix 3G)

is equivalent to

ETSI TS | TR 1nn nnn "[Digital cellular telecommunications system (Phase 2+) (GSM);] Universal Mobile Telecommunications System; <title>

For GSM document identities of type "GSM xx.yy", e.g. GSM 01.04, the corresponding ETSI document identity may be found in the Cross Reference List on www.etsi.org/key

Contents

Foreword	5
1 Scope.....	6
2 References.....	6
3 Definitions, symbols and abbreviations	6
3.1 Definitions	6
3.2 Symbols	7
3.3 Abbreviations.....	7
4 General Aspects	8
4.1 Introduction.....	8
4.2 Iub Interface General Principles	8
4.3 Iub Interface Specification Objectives	8
4.4 Iub Interface Capabilities.....	8
4.4.1 Radio application related signalling	9
4.4.2 Iub/Iur DCH data stream	9
4.4.3 Iub RACH data stream.....	9
4.4.4 Iub FACH data stream.....	9
4.4.5 Iub DSCH data stream.....	9
4.4.6 Iub TDD USCH data stream	9
4.4.7 Iub PCH data stream	9
4.5 Iub Interface Characteristics	9
4.5.1 Mapping of Iub data streams.....	9
4.6 Iub Protocols.....	10
5 Functions of the I _{ub} Interface Protocols	10
5.1 Iub Functions	10
5.2 Functional split over Iub.....	11
5.2.1 Management of Iub Transport Resources.....	11
5.2.2 Logical O&M of Node B	11
5.2.2.1 Handling of Node B Hardware Resources.....	11
5.2.3 Implementation Specific O&M Transport.....	11
5.2.4 System Information Management	11
5.2.5 Traffic management of Common Channels	12
5.2.6 Traffic management of Dedicated Channels	12
5.2.6.1 FDD Macro-diversity Combining and Control.....	12
5.2.6.2 Handover Decision	12
5.2.6.3 Allocation of Physical Channel Resources.....	12
5.2.6.4 UpLink Power Control	12
5.2.6.5 Down-Link Power Control.....	12
5.2.6.6 Admission Control.....	12
5.2.6.7 Power and Interference Reporting	13
5.2.7 Traffic management of Shared Channels	13
5.2.8 Timing and Synchronisation Management.....	13
6 Node B logical Model over Iub	13
6.1 Overview.....	13
6.2 Elements of the logical model.....	14
6.2.1 Node B Communication Contexts for Dedicated and Shared Channels	14
6.2.2 Common Transport Channels.....	14
6.2.3 Transport network logical resources	15
6.2.3.1 Node B Control Port.....	15
6.2.3.2 Communication Control Port.....	15
6.2.3.3 Traffic Termination Point.....	15
6.2.3.4 Iub DCH Data Port	15
6.2.3.5 Iub RACH Data Port	15
6.2.3.6 Iub FACH Data Port.....	15

6.2.3.7	Iub DSCH Data Port.....	15
6.2.3.8	Iub TDD USCH Data Port.....	15
6.2.3.9	Iub PCH Data Port.....	15
6.2.4	Radio Network Logical resources	16
6.2.4.1	Common Resources.....	16
6.2.4.2	Cell	16
6.2.4.3	Common Physical Channels and Common Transport Channels	18
7	Iub Interface Protocol Structure.....	20
8	Other Iub Interface Specifications	20
8.1	UTRAN Iub Interface: Layer 1 (TSG RAN 25.431)	20
8.2	UTRAN Iub Interface: Signalling Transport (TSG RAN 25.432).....	20
8.3	NBAP Specification (TSG RAN 25.433)	20
8.4	UTRAN Iub Interface: Data Transport & Transport Signalling for Common Transport Channel Data Streams (TSG RAN 25.434).....	21
8.5	UTRAN Iub Interface: User Plane Protocols for Common Transport Channel Data Streams (TSG RAN 25.435)	21
8.6	UTRAN Iur/Iub Interface: Data Transport & Transport Signalling for DCH Data Streams (TSG RAN 25.426).....	21
8.7	UTRAN Iur/Iub Interface: User Plane Protocol for DCH Data Streams (TSG RAN 25.427).....	21
8.8	Summary of UTRAN Iub Interface Technical Specifications	21
	Annex A (informative): Change history.....	23
	History.....	24

Foreword

This Technical Specification has been produced by the 3GPP.

The contents of the present document are subject to continuing work within the TSG and may change following formal TSG approval. Should the TSG modify the contents of this TS, it will be re-released by the TSG with an identifying change of release date and an increase in version number as follows:

Version x.y.z

where:

- x the first digit:
 - 1 presented to TSG for information;
 - 2 presented to TSG for approval;
 - 3 Indicates TSG approved document under change control.
- y the second digit is incremented for all changes of substance, i.e. technical enhancements, corrections, updates, etc.
- z the third digit is incremented when editorial only changes have been incorporated in the document.

1 Scope

The present document is an introduction to the TSG RAN TS 25.43x series of UMTS Technical Specifications that define the Iub Interface. The Iub interface is a logical interface for the interconnection of Node B and Radio Network Controller (RNC) components of the UMTS Terrestrial Radio Access Network (UTRAN) for the UMTS system.

2 References

The following documents contain provisions which, through reference in this text, constitute provisions of the present document.

- References are either specific (identified by date of publication, edition number, version number, etc.) or non-specific.
- For a specific reference, subsequent revisions do not apply.
- For a non-specific reference, the latest version applies.

- [1] 3G TS 25.401: "UTRAN Overall Description".
- [2] 3G TS 25.442: "UTRAN Implementation Specific O&M transport".
- [3] 3G TS 25.432: "UTRAN Iub interface signalling transport".
- [4] 3G TS 25.302: "Services Provided by the Physical Layer".
- [5] 3G TS 25.431: "UTRAN Iub Interface: Layer 1".
- [6] 3G TS 25.432: "UTRAN Iub Interface: Signalling Transport".
- [7] 3G TS 25.433: "NBAP Specification".
- [8] 3G TS 25.434: "UTRAN Iub Interface: Data Transport & Transport Signalling for Common Transport Channel Data Streams".
- [9] 3G TS 25.435: "UTRAN Iub Interface: User Plane Protocols for Common Transport Channel Data Streams".
- [10] 3G TS 25.426: "UTRAN Iur/Iub Interface: Data Transport & Transport Signalling for DCH Data Streams".
- [11] 3G TS 25.427: "UTRAN Iur/Iub Interface: User Plane Protocol for DCH Data Streams".
- [12] 3G TS 25.402: "Synchronisation in UTRAN, Stage 2".

3 Definitions, symbols and abbreviations

3.1 Definitions

For the purposes of the present document, the following terms and definitions apply.

Propagation delay (PD): It is the round trip propagation delay of the radio signal from the Node B to the UE and back to the BS in one chip resolution.

Timing Advance (TA): It is the amount of time, expressed in number of chips, by which the transmission of an uplink burst is anticipated by the UE in order to be received by the cell inside the corresponding time slot.

3.2 Symbols

No special symbols are defined in this document.

3.3 Abbreviations

For the purposes of the present document, the following abbreviations apply:

AAL2	ATM Adaptation Layer type 2
AAL5	ATM Adaptation Layer type 5
AICH	Acquisition Indication Channel
ALCAP	Access Link Control Application Part
ATM	Asynchronous Transfer Mode
BCH	Broadcast Channel
BCCH	Broadcast Control Channel
CCH	Control Channel
CPCId	Common Physical Channel Identifier
CPICH	Common Pilot Channel
CTCId	Common Transport Channel Identifier
CRNC	Controlling Radio Network Controller
DCH	Dedicated Transport Channel
DPCCCH	Dedicated Physical Control Channel
DPCH	Dedicated Physical Channel
DRNC	Drift Radio Network Controller
DSCH	Down-link Shared Channel
FACH	Forward Access Channel
FAUSCH	Fast Up-link Signalling Channel
FDD	Frequency Division Duplex
FP	Frame Protocol
NBAP	NodeB Application Part
O&M	Operation and Maintenance
PICH	Page Indication Channel
PCCH	Paging Control Channel
PCCPCH	Primary Common Control Physical Channel
PCPICH	Primary Common Pilot Channel
PCH	Paging Channel
PDSCH	Physical Downlink Shared Channel
PRACH	Physical Random Access Channel
PUSCH	Physical Uplink Shared Channel
RACH	Random Access Channel
RNC	Radio Network Controller
RNS	Radio Network Subsystem
SCCP	Signalling Connection Control Part
SCH	Synchronisation Channel
SCCPCH	Secondary Common Control Physical Channel
SCPICH	Secondary Common Pilot Channel
SRNC	Serving Radio Network Controller
SSCF-UNI	Service Specific Co-ordination Function – User Network Interface
SSCOP	Service Specific Connection Oriented Protocol
TDD	Time Division Duplex
UE	User Equipment
UC-ID	UTRAN Cell Identifier
UMTS	Universal Mobile Telecommunication System
USCH	Up-link Shared Channel
UTRAN	UMTS Terrestrial Radio Access Network

4 General Aspects

4.1 Introduction

The logical interface between a RNC and a Node B is called the Iub interface.

4.2 Iub Interface General Principles

The general principles for the specification of the Iub interface are as follows:

- Transmission sharing between the GSM/GPRS Abis interface and the Iub interface shall not be precluded.
- The functional division between RNC and NodeB shall have as few options as possible.
- Iub should be based on a logical model of NodeB.
- NodeB controls a number of cells and can be ordered to add/remove radio links in those cells.
- Neither the physical structure nor any internal protocols of the NodeB shall be visible over Iub and are thus not limiting factors, e.g., when introducing future technology.
- Only the logical O&M [1] of NodeB is supported by the Iub.
- Complex functionality shall as far as possible be avoided over Iub. Advanced optimisation solutions may be added in later versions of the standard.
- The Iub functional split shall take into account the probability of frequent switching between different channel types.

4.3 Iub Interface Specification Objectives

The I_{ub} interface specifications shall facilitate the following:

- Inter-connection of RNCs and NodeBs from different manufacturers.
- Separation of I_{ub} interface Radio Network functionality and Transport Network functionality to facilitate introduction of future technology.

The Iub parts to be standardised are:

1. User data transport
2. Signalling for handling the user data
3. NodeB Logical O&M [1] ¹.

4.4 Iub Interface Capabilities

The Iub interface connects a RNC and a Node B.

The information transferred over the Iub reference point can be categorised as follows:

¹ It should be possible to transport the Implementation Specific O&M [1] interface via the same transport bearer as the Iub interface and, hence, the lower layer transport mechanisms should be standardised to this effect. The application level content of the Implementation Specific O&M interface is out of scope of UTRAN standardisation. Where the implementation specific O&M interface shares the same bearer as the Iub interface, the transport layers shall be as specified in [2] and [3] respectively.

4.4.1 Radio application related signalling

The Iub interface allows the RNC and the Node B to negotiate about radio resources, for example to add and delete cells controlled by the Node B to support communication of the dedicated connection between UE and SRNC. Information used to control the broadcast channel and information to be transported on the broadcast channel belong to this category also. In addition, logical O&M [1] between the Node B and RNC shall also be included in this category.

4.4.2 Iub/Iur DCH data stream

The Iub interface provides the means for transport of uplink and downlink DCH transport frames between RNC and Node B.

4.4.3 Iub RACH data stream

The Iub interface provides the means for transport of uplink RACH transport frames between Node B and RNC.

4.4.4 Iub FACH data stream

The Iub interface provides the means for transport of downlink FACH transport frames between RNC and Node B.

4.4.5 Iub DSCH data stream

The Iub interface provides the means for transport of downlink shared channel, DSCH, data frames between RNC and Node B.

4.4.6 Iub TDD USCH data stream

The Iub interface provides the means for transport of uplink shared channel, USCH, data frames between Node B and RNC.

4.4.7 Iub PCH data stream

The Iub interface provides the means for transport of PCH transport frames between RNC and Node B.

4.5 Iub Interface Characteristics

4.5.1 Mapping of Iub data streams

DCH	One Iub DCH data stream is carried on one transport bearer except in the case of coordinated DCHs in which case a set of coordinated DCHs are multiplexed onto the same transport bearer.
RACH	One Iub RACH data stream is carried on one transport bearer. For each RACH in a cell, an Iub RACH data stream must be established over the Iub interface.
FACH	One Iub FACH data stream is carried on one transport bearer. For each FACH in a cell, an Iub FACH data stream must be established over the Iub Interface.
DSCH	One Iub DSCH data stream is carried on one transport bearer.
TDD USCH	One Iub TDD USCH data stream is carried on one transport bearer.
PCH	One Iub PCH data stream is carried on one transport bearer.

4.6 Iub Protocols

There shall exist a clear separation between the radio network layer and the transport layer. Therefore, the radio network signalling and Iub data streams are separated from the data transport resource and traffic handling as shown in Figure 1. This resource and traffic handling is controlled by the Transport Signalling. The Transport Signalling is carried by a Signalling Bearer over the Iub interface.

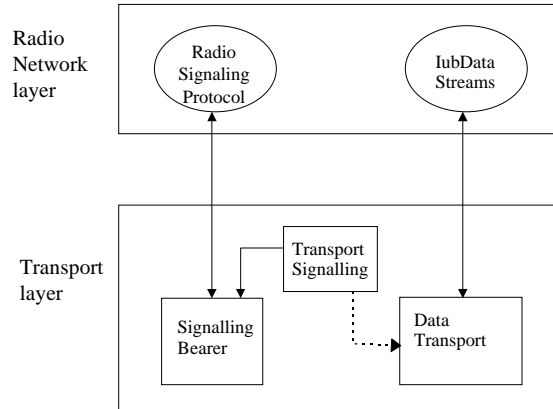

Figure 1: Separation of Radio Network protocols and transport over Iub

5 Functions of the I_{ub} Interface Protocols

5.1 Iub Functions

The list of functions on the Iub interface is the following:

1. Management of Iub Transport Resources
2. Logical O&M of Node B
 - Iub Link Management
 - Cell Configuration Management
 - Radio Network Performance Measurements
 - Resource Event Management
 - Common Transport Channel Management
 - Radio Resource Management
 - Radio Network Configuration Alignment
3. Implementation Specific O&M Transport
4. System Information Management
5. Traffic Management of Common Channels
 - Admission Control
 - Power Management
 - Data Transfer
6. Traffic Management of Dedicated Channels
 - Radio Link Management

- Radio Link Supervision
 - Channel Allocation / De-allocation
 - Power Management
 - Measurement Reporting
 - Dedicated Transport Channel Management
 - Data Transfer
7. Traffic Management of Shared Channels
- Channel Allocation / De-allocation
 - Power Management
 - Transport Channel Management
 - Data Transfer
8. Timing and Synchronisation Management
- Transport Channel Synchronisation (Frame synchronisation)
 - Node B – RNC node Synchronisation
 - Inter Node B node Synchronisation

5.2 Functional split over Iub

5.2.1 Management of Iub Transport Resources

The underlying transport resources (AAL2 connections) shall be set up and controlled by the RNC. Further information on these functions is provided in the transport layer specifications [3], [8], [10].

5.2.2 Logical O&M of Node B

Logical O&M is the signalling associated with the control of logical resources (channels, cells,...) owned by the RNC but physically implemented in the Node B. The RNC controls these logical resources. A number of O&M procedures physically implemented in Node B impact on the logical resources and therefore require an information exchange between RNC and Node B. All messages needed to support this information exchange are classified as Logical O&M forming an integral part of NBAP over the Iub interface.

5.2.2.1 Handling of Node B Hardware Resources

Mapping of Node B logical resources onto Node B hardware resources, used for Iub data streams and radio interface transmission/reception, is performed by Node B.

5.2.3 Implementation Specific O&M Transport

The Iub interface may support the transport of Implementation specific O&M information. Further detail on this can be found in the UMTS technical specification on Implementation Specific O&M Transport [2].

5.2.4 System Information Management

System Information is sent by the CRNC to a Node B. Scheduling of system broadcast information is also carried out in the CRNC. System information and scheduling information are sent by the CRNC to the Node B. The Node B is responsible for transmitting the received system information according to the scheduling parameters provided.

5.2.5 Traffic management of Common Channels

The common channels need to be controlled from the RNC. This is typically the control of the RACH and FACH channels, the information that is broadcast on the Broadcast control channel, and the control and request for sending information on the paging channels.

5.2.6 Traffic management of Dedicated Channels

These functions are related to the activation of logical resources (e.g. Radio Links, Iub ports), and the connection of these various resources together.

Some freedom may be left for Node B implementation on some functions like soft combining for FDD within Node B, since soft combining has merits for being executed as close as possible to the radio (both in terms of transmission cost and efficiency).

5.2.6.1 FDD Macro-diversity Combining and Control

Node B may perform macro-diversity combining/splitting of data streams communicated via its cells. RNC performs macro-diversity combining/splitting of Iub data streams received from/sent to several Node B(s).

When requesting the addition of a new cell for a UE-UTRAN connection, the RNC can explicitly request to the Node B a new Iub data stream, in which case the macro-diversity combining and splitting function within the Node B is not used for that cell. Otherwise, the Node B takes the decision whether macro-diversity combining and splitting function is used inside the Node B for that cell i.e. whether a new Iub data stream shall be added or not.

The internal Node B handling of the macro-diversity combining/splitting of radio frames is controlled by the Node B.

5.2.6.2 Handover Decision

To support mobility of the UE to UTRAN connection between cells, UTRAN uses measurement reports from the UE and detectors at the cells.

The RNC takes the decision to add or delete cells from the connection.

5.2.6.3 Allocation of Physical Channel Resources

In FDD allocation of downlink channelisation codes of cells belonging to Node B is performed in the CRNC.

In TDD allocation of uplink and downlink physical channel resources of cells belonging to Node B is performed in the CRNC.

5.2.6.4 UpLink Power Control

This function controls the level of the transmitted power in order to minimise interference and keep the quality of the connections. The function uplink Outer Loop Power Control located in the SRNC sets the target quality for the uplink Inner Loop Power Control function. In FDD Inner Loop Power Control Function is located in Node B, while in TDD it is located in the UE.

5.2.6.5 Down-Link Power Control

This function controls the level of the downlink transmitted power. In FDD it is also used to correct the downlink power drifting between several radio links. A SRNC regularly (or under some algorithms) shall send the target downlink power range based on the measurement report from UE.

5.2.6.6 Admission Control

The Admission Control function based on uplink interference and downlink power is located in the CRNC.

Node B shall report uplink interference measurements and downlink power information over the Iub.

The CRNC controls this reporting function, i.e. if this information needs to be reported and the period of these reports.

5.2.6.7 Power and Interference Reporting

A threshold for reporting may be given to NodeB from the CRNC to prevent frequent reporting over the Iub. NodeB shall have a function to measure "uplink interference level and downlink TX Power" and a function to compare the averaged "uplink interference level and downlink TX power" with the threshold value. NodeB shall also have a function to report when the average measured value exceeds the threshold value. The CRNC shall have a function to modify the "threshold value" for neighbour cell co-ordination.

An indication of exceeding uplink interference threshold or downlink TX power may be included as a cause of failure when a NodeB is requested to set-up a radio link or add to an existing radio link. This may be used when a number of radio links set-up requests or additions are received on the Iub during the reporting interval.

5.2.7 Traffic management of Shared Channels

The shared channels shall be controlled from the RNC. This is typically the control of the DSCH channels and the TDD USCH channels.

5.2.8 Timing and Synchronisation Management

The Iub interface shall support timing and synchronisation management functions. Further detail regarding these functions can be found in the UMTS technical specification on UTRAN synchronisation [12].

6 Node B logical Model over Iub

6.1 Overview

The model described in Figure 2 shows the Node B as seen from the controlling RNC. The model includes:

- the logical resources provided by Node B to UTRAN (via its Controlling RNC) – depicted as "cells" which include the physical channel resources DPCH, PDSCH, and PUSCH.
- the dedicated channels which have been established on Node B.
- the common transport channels that Node B provides to the RNC.

The procedures for controlling the connections between radio links and Iub DCH data ports are sent from the RNC to the Node B via the Communication Control Ports.

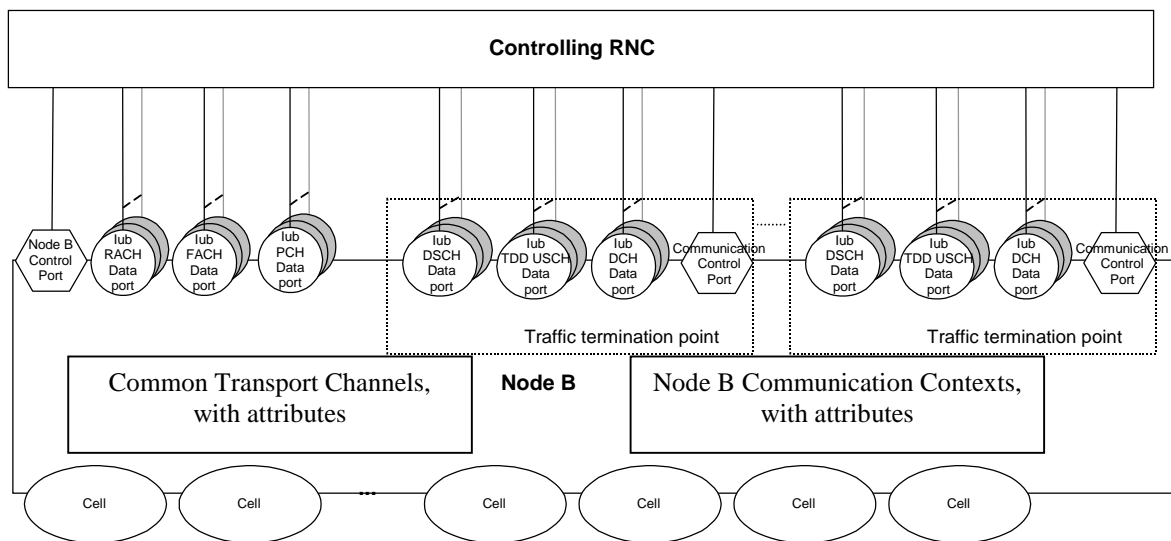

Figure 2: Logical Model of Node B

6.2 Elements of the logical model

6.2.1 Node B Communication Contexts for Dedicated and Shared Channels

A Node B Communication Context corresponds to all the dedicated resources that are necessary for a user in dedicated mode and using dedicated and/or shared channels as restricted to a given Node B. [In TDD, the NodeB Communication Context also exists for users in Cell_FACH mode (i.e. non-dedicated mode) provided a USCH and/or DSCH has been allocated to these users.]

There are a number of Node B Communication Contexts inside a given Node B.

The attributes to a Node B Communication Context shall include the following (not exhaustive):

- The list of Cells where dedicated and/or shared physical resources are used.
- The list of DCH which are mapped on the dedicated physical resources for that Node B Communication Context.
- The list of DSCH and (TDD) USCH which are used by the respective UE.
- The complete DCH characteristics for each DCH, identified by its DCH-identifier [4].
- The complete Transport Channel and Physical Channel characteristics for each DSCH and USCH, identified by its Physical Shared Channel identifier [4].
- The list of Iub DCH Data Ports.
- The list of Iub DSCH Data ports and Iub USCH data ports.
- For each Iub DCH Data Port, the corresponding DCH and cells which are carried on this data port.
- For each Iub DSCH and USCH data port, the corresponding DSCH or USCH and cells which serve that DSCH or USCH.
- Physical layer parameters (outer loop power control, etc).

6.2.2 Common Transport Channels

Common Transport Channels are defined in [2]. A Common Transport Channel is configured in the Node B, on request of the CRNC.

The BCH is carried directly on the Node B control port using NBAP procedures. This Common Channel will not be mapped to an individual data port.

The RACH has an associated Iub RACH Data Port and the FACH has an associated Iub FACH Data Port.

The Iub DSCH data port is associated to one DSCH and to one NodeB Communication Context.

[TDD - the Iub USCH data port is associated to one USCH and to one NodeB Communication Context.]

The attributes of a Common transport channel shall include (not exhaustive):

- Type (RACH, FACH, DSCH, USCH, PCH).
- Associated Iub RACH Data Port for a RACH, Iub FACH Data Port for a FACH, Iub PCH Data Port for the PCH.
- List of associated Iub FDD DSCH Data ports for the DSCH (FDD only).
- Physical parameters.

6.2.3 Transport network logical resources

6.2.3.1 Node B Control Port

The Node B Control Port is used to exchange the signalling information for the logical O&M of Node B, the creation of Node B Communication Contexts, the configuration of the common transport channels that Node B provides in a given cell, PCH and BCH control information between the RNC and the Node B. The Node B Control Port corresponds to one signalling bearer between the controlling RNC and the Node B. There is one Node B Control Port per Node B.

6.2.3.2 Communication Control Port

A Communication Control Port corresponds to one signalling bearer between the RNC and Node B for the control of Node B Communication Contexts. One signalling bearer between RNC and Node B can at most correspond to one Communication Control Port. Node B may have multiple Communication Control Ports (one per Traffic Termination Point). The Communication Control Port is selected at creation of the Node B Communication Context.

6.2.3.3 Traffic Termination Point

Traffic Termination Point represents DCH, DSCH and TDD USCH data streams belonging to one or more Node B Communication Contexts (UE contexts), which are controlled via one Communication Control Port. The Traffic Termination Point is thus a descriptive entity which neither is controlled over Iub nor by O&M.

6.2.3.4 Iub DCH Data Port

One Iub DCH Data port represents one user plane transport bearer. One user plane transport bearer will carry only one DCH data stream except in the case of coordinated DCHs, in which case the data streams of all combined DCHs shall be multiplexed on one and the same user plane transport bearer.

6.2.3.5 Iub RACH Data Port

An Iub RACH Data Port represents a user plane bearer carrying one Iub RACH Data Stream between the Node B and the RNC. There is one RACH Data Port for each RACH channel of Node B.

6.2.3.6 Iub FACH Data Port

An Iub FACH Data Port represents a user plane bearer carrying one Iub FACH Data Stream between the Node B and the RNC. There is one CCH Data Port for each FACH channel of Node B.

6.2.3.7 Iub DSCH Data Port

An Iub DSCH Data Port represents a user plane bearer carrying one Iub DSCH Data Stream between the Node B and the RNC. For each DSCH, that is used by an individual UE, there is one Iub DSCH Data Port per NodeB exclusively assigned to the communication context of that UE. In FDD each DSCH is associated with a downlink DPCCH.

6.2.3.8 Iub TDD USCH Data Port

An Iub TDD USCH Data Port represents a user plane bearer carrying one Iub TDD USCH Data Stream between the Node B and the RNC. For each USCH, that is used by an individual UE, there is one Iub TDD USCH Data Port with data exclusively assigned to the NodeB communication context of that UE.

6.2.3.9 Iub PCH Data Port

An Iub PCH Data Port represents an Iub PCH Data Stream between the Node B and the RNC.

6.2.4 Radio Network Logical resources

6.2.4.1 Common Resources

The CRNC manages logical radio network resources in Node B and needs to use both common and dedicated resources in a Node B to run a radio network. Therefore, it is the CRNC that orders the Node B to configure, reconfigure and delete these resources. However, if the equipment in Node B cannot fully support the configuration that the CRNC requests, or the equipment breaks down, then Node B can indicate the availability of the common resources (i.e. both downgrade and upgrade).

The common resources are the Cell, the common physical channels and the common transport channels.

In Node B these common resources have an operational state, that indicates whether they are operational or not, i.e. whether they can carry traffic or not.

Figure 3 shows the common resources that a CRNC is managing in a Node B to be able to run a radio network.

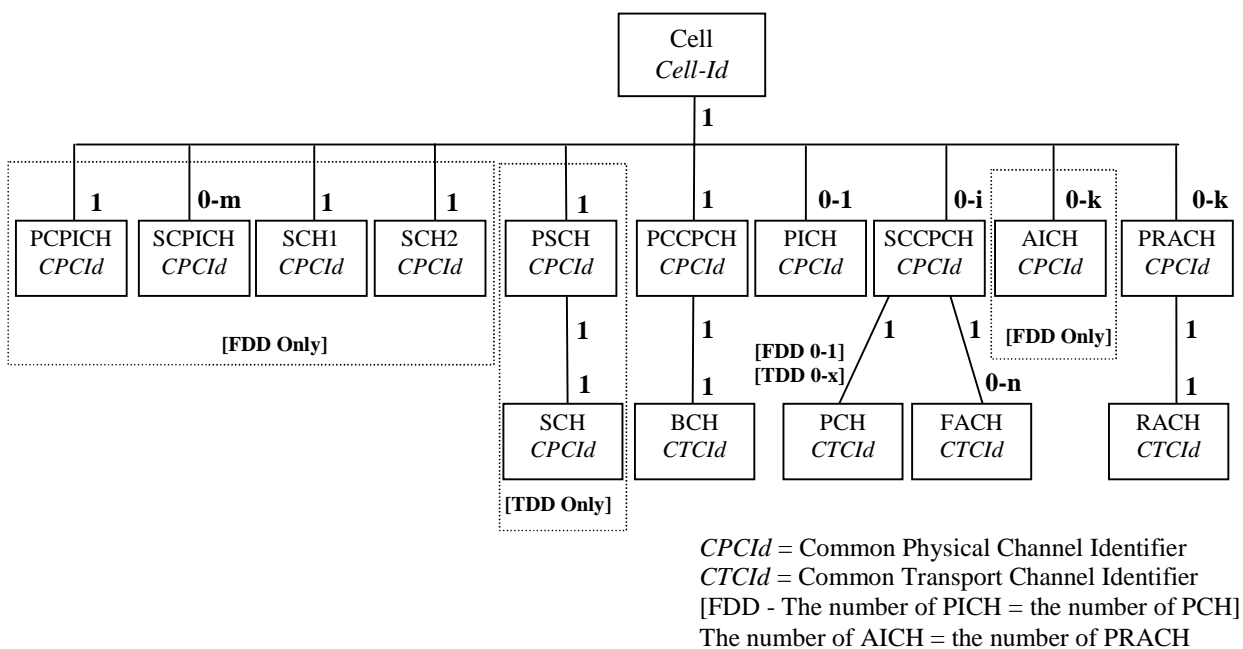

Figure 3: Common resources in a Node B that are managed by the CRNC

6.2.4.2 Cell

A Cell is identified by a UTRAN Cell identifier (UC-id) [1].

The semantics of a Cell include the following:

- The Cell can be created and removed by administrative procedures. When a Local Cell, i.e. equipment in a Node B, is made available to the CRNC for configuration of a cell, the CRNC can configure the cell with configuration data, common physical channels and common transport channels in Node B. In so doing a Local cell is added to the RNS.
- If any Iub transport bearers for common or dedicated transport channels exists when the cell is deleted, the Node B shall take no action to release those transport bearers.
- Node B may support one or more cells.

- Configuration of a cell over the Iub interface cannot be successful unless Node B has reported a Local Cell Id [1] as available to the CRNC.
- Once a Local Cell is configured to support a cell, it cannot be deleted without the CRNC first deleting the cell.

Figure 4 illustrates the state diagram for a Local Cell in Node B, as seen over the Iub interface.

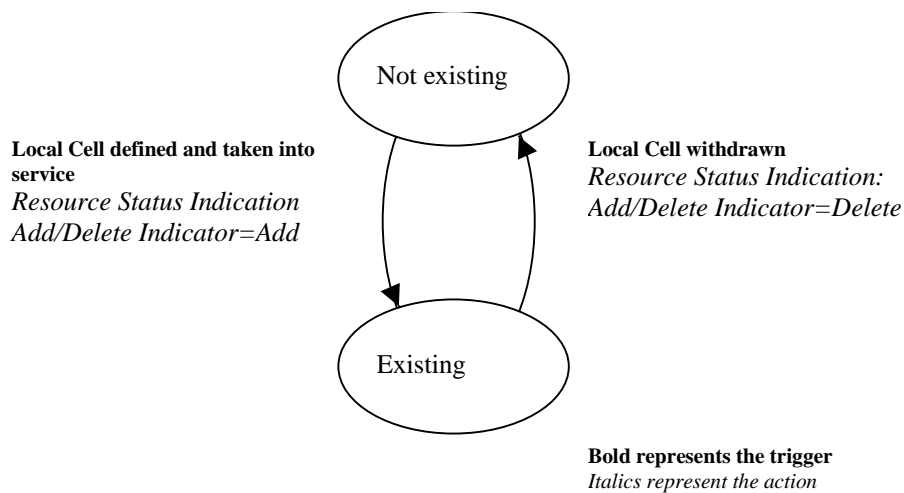

Figure 4: States for a Local Cell that are seen over the Iub interface

Cells in Node B have a resource operational state.

Figure 5 illustrates the state diagram for the states of a cell, as seen over the Iub interface.

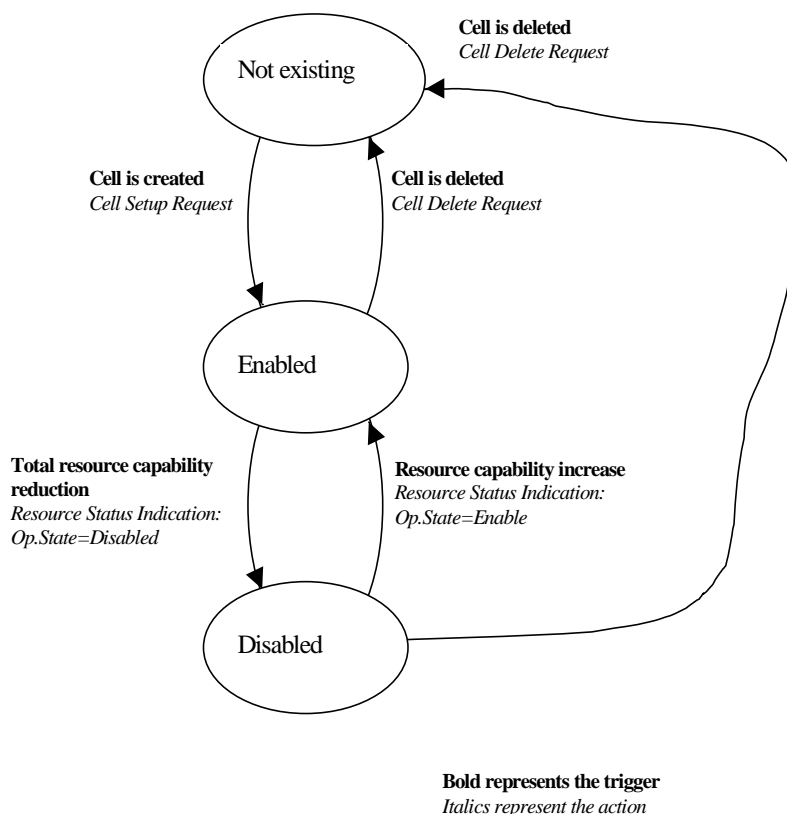

Figure 5: States for a cell in Node B, as reported to the CRNC

There are three states seen over the Iub interface:

1. Not existing, meaning that the cell does not exist in Node B.
2. enabled, meaning that the resource can be used by the RNC.
3. disabled, meaning that the resource cannot be used by the RNC.

When a cell becomes disabled in Node B, that shall be reported to the CRNC together with the cause.

6.2.4.3 Common Physical Channels and Common Transport Channels

Common physical channels and common transport channels in Node B have a resource operational state.

Figure 6 illustrates the state diagram for common physical channels and common transport channels in Node B, as seen over the Iub interface.

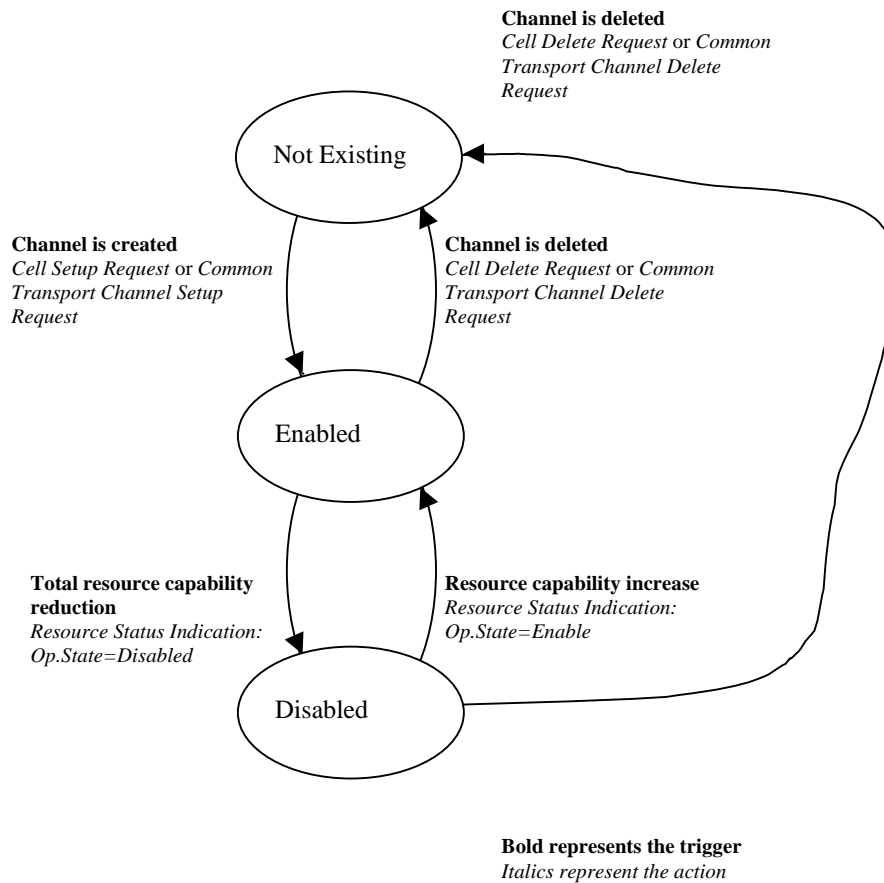

Figure 6: States for a common channel in Node B, as reported to the CRNC.

There are three states seen over the Iub interface:

1. Not existing, meaning that the resource does not exist in Node B.
2. enabled, meaning that the resource can be used by the RNC.
3. disabled, meaning that the resource cannot be used by the RNC.

When a channel becomes disabled in the Node B, this shall be reported to the CRNC together with the cause.

7 Iub Interface Protocol Structure

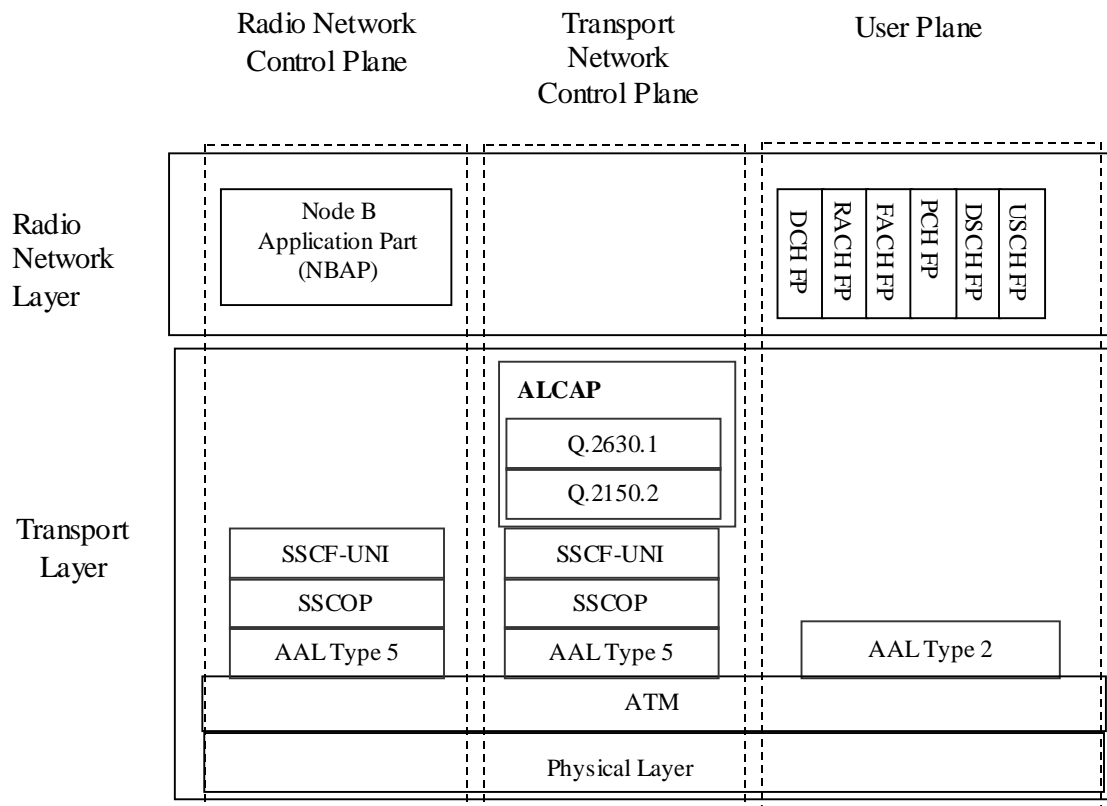

Figure 7: Iub Interface Protocol Structure.

The Iub interface protocol architecture consists of two functional layers:

1. Radio Network Layer, defines procedures related to the operation of Node B. The radio network layer consists of a radio network control plane and a radio network user plane.
2. Transport Layer, defines procedures for establishing physical connections between Node B and the RNC.

There shall be one dedicated AAL2 connection for each RACH and each FACH transport channel.

8 Other Iub Interface Specifications

8.1 UTRAN Iub Interface: Layer 1 (TSG RAN 25.431)

This document[5] specifies the standards allowed for the implement of Layer 1 (physical layer) on the I_{ub} interface.

8.2 UTRAN Iub Interface: Signalling Transport (TSG RAN 25.432)

This document[6] specifies the signalling transport related to NBAP signalling to be used across the Iub Interface.

8.3 NBAP Specification (TSG RAN 25.433)

This document[7] specifies the standards for NBAP specification to be used over Iub Interface.

8.4 UTRAN Iub Interface: Data Transport & Transport Signalling for Common Transport Channel Data Streams (TSG RAN 25.434)

This document[8] provides a specification of the UTRAN RNC-Node B (Iub) interface Data Transport and Transport Signalling for Common Transport Channel data streams.

8.5 UTRAN Iub Interface: User Plane Protocols for Common Transport Channel Data Streams (TSG RAN 25.435)

This document[9] provides a specification of the UTRAN RNC-Node B (Iub) interface user plane protocols for Common Transport Channel data streams.

8.6 UTRAN Iur/Iub Interface: Data Transport & Transport Signalling for DCH Data Streams (TSG RAN 25.426)

This Technical Specification[10] specifies the transport bearers for the DCH data streams on UTRAN Iur and Iub interfaces. The corresponding Transport Network Control plane is also specified.

8.7 UTRAN Iur/Iub Interface: User Plane Protocol for DCH Data Streams (TSG RAN 25.427)

This document[11] provides a specification of the UTRAN Iur and Iub interfaces user plane protocols for Dedicated Transport Channel data streams.

8.8 Summary of UTRAN Iub Interface Technical Specifications

The relationship between the technical specifications that define the UTRAN Iub interface is shown in figure 8.

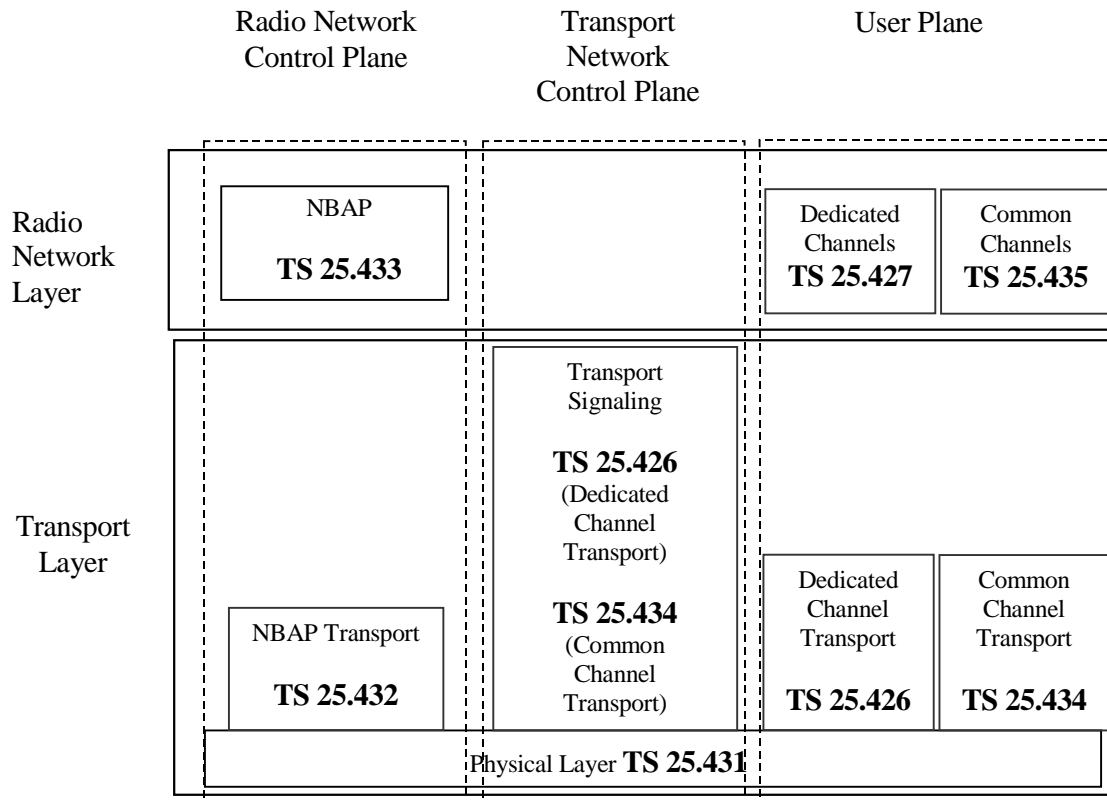

Figure 8: Iub Interface Technical Specifications.

Annex A (informative): Change history

Change history					
TSG RAN#	Version	CR	Tdoc RAN	New Version	Subject/Comment
RAN_06	-	-	RP-99762	3.0.0	Approved at TSG RAN #6 and placed under Change Control
<p>Rapporteur for TS25.430 is:</p> <p>Mick Wilson Fujitsu Europe Telecom R&D Centre</p> <p>Tel.: +44 181 606 4801 Fax : +44 181 573 3602 Email : m.wilson@fujitsu.co.uk</p>					

History

Document history		
V3.0.0	January 2000	Publication