

# ETSI TS 125 401 V11.1.0 (2013-01)



## **Universal Mobile Telecommunications System (UMTS); UTRAN overall description (3GPP TS 25.401 version 11.1.0 Release 11)**



---

**Reference**

RTS/TSGR-0325401vb10

---

**Keywords**

UMTS

**ETSI**

650 Route des Lucioles  
F-06921 Sophia Antipolis Cedex - FRANCE

---

Tel.: +33 4 92 94 42 00 Fax: +33 4 93 65 47 16

Siret N° 348 623 562 00017 - NAF 742 C  
Association à but non lucratif enregistrée à la  
Sous-Préfecture de Grasse (06) N° 7803/88

---

**Important notice**

---

Individual copies of the present document can be downloaded from:

<http://www.etsi.org>

The present document may be made available in more than one electronic version or in print. In any case of existing or perceived difference in contents between such versions, the reference version is the Portable Document Format (PDF). In case of dispute, the reference shall be the printing on ETSI printers of the PDF version kept on a specific network drive within ETSI Secretariat.

Users of the present document should be aware that the document may be subject to revision or change of status. Information on the current status of this and other ETSI documents is available at

<http://portal.etsi.org/tb/status/status.asp>

If you find errors in the present document, please send your comment to one of the following services:

[http://portal.etsi.org/chaicor/ETSI\\_support.asp](http://portal.etsi.org/chaicor/ETSI_support.asp)

---

**Copyright Notification**

---

No part may be reproduced except as authorized by written permission.  
The copyright and the foregoing restriction extend to reproduction in all media.

© European Telecommunications Standards Institute 2013.  
All rights reserved.

**DECT™**, **PLUGTESTS™**, **UMTS™** and the ETSI logo are Trade Marks of ETSI registered for the benefit of its Members.  
**3GPP™** and **LTE™** are Trade Marks of ETSI registered for the benefit of its Members and  
of the 3GPP Organizational Partners.  
**GSM®** and the GSM logo are Trade Marks registered and owned by the GSM Association.

---

## Intellectual Property Rights

IPRs essential or potentially essential to the present document may have been declared to ETSI. The information pertaining to these essential IPRs, if any, is publicly available for **ETSI members and non-members**, and can be found in ETSI SR 000 314: "*Intellectual Property Rights (IPRs); Essential, or potentially Essential, IPRs notified to ETSI in respect of ETSI standards*", which is available from the ETSI Secretariat. Latest updates are available on the ETSI Web server (<http://ipr.etsi.org>).

Pursuant to the ETSI IPR Policy, no investigation, including IPR searches, has been carried out by ETSI. No guarantee can be given as to the existence of other IPRs not referenced in ETSI SR 000 314 (or the updates on the ETSI Web server) which are, or may be, or may become, essential to the present document.

---

## Foreword

This Technical Specification (TS) has been produced by ETSI 3rd Generation Partnership Project (3GPP).

The present document may refer to technical specifications or reports using their 3GPP identities, UMTS identities or GSM identities. These should be interpreted as being references to the corresponding ETSI deliverables.

The cross reference between GSM, UMTS, 3GPP and ETSI identities can be found under <http://webapp.etsi.org/key/queryform.asp>.

# Contents

Intellectual Property Rights .....	2
Foreword.....	2
Foreword.....	6
1 Scope .....	7
2 References .....	7
3 Definitions and abbreviations.....	8
3.1 Definitions .....	8
3.2 Abbreviations .....	10
3.3 Notation.....	12
4 General principles .....	13
5 UMTS General architecture .....	13
5.1 Overview .....	13
5.2 General protocols architecture.....	14
5.2.1 User plane .....	14
5.2.2 Control plane .....	15
6 UTRAN Architecture .....	15
6.1 UTRAN Identifiers.....	20
6.1.1 PLMN Identity.....	20
6.1.2 CN Domain Identifier .....	20
6.1.3 RNC Identifier .....	20
6.1.4 Service Area Identifier.....	20
6.1.5 Cell Identifier.....	20
6.1.6 Local Cell Identifier.....	20
6.1.7 UE Identifiers.....	20
6.1.7.1 Usage of RNTI.....	22
6.1.7a UE Identifiers in GERAN A/Gb mode (1.28Mcps TDD).....	22
6.1.8 Identifiers for dedicated resources within UTRAN .....	22
6.1.8.1 Radio Network Control Plane identifiers .....	22
6.1.8.2 Transport Network Identifiers.....	22
6.1.8.3 Binding identifier .....	23
6.1.9 URA Identity .....	25
6.1.10 Service Identifiers for MBMS .....	25
6.1.10.1 IP Multicast Address and APN .....	25
6.1.10.2 TMGI .....	25
6.1.10.3 Session Identifier.....	25
6.1.10.4 MBMS Service Area .....	25
6.1.10.5 MBMS Cell Group Identifier .....	25
6.1.10.6 MBMS UTRAN Cell Group Identifier .....	25
6.1.11 Transport Network Identifiers for MBMS .....	25
6.1.12 Binding Identifiers for MBMS.....	26
6.1.13 Use of Extended Identifiers .....	26
6.2 Transport Addresses.....	26
6.3 Function Distribution Principles.....	26
7 UTRAN Functions description.....	27
7.1 List of functions .....	27
7.2 Functions description .....	28
7.2.0 Transfer of user data .....	28
7.2.1 Functions related to overall system access control .....	28
7.2.1.1 Admission Control .....	28
7.2.1.2 Congestion Control .....	28
7.2.1.3 System information broadcasting.....	29

7.2.1.4	MOCN and GWCN configuration support .....	29
7.2.2	Radio channel ciphering and deciphering .....	29
7.2.3	Functions related to Mobility .....	29
7.2.3.1	Handover .....	29
7.2.3.2	SRNS Relocation .....	29
7.2.3.3	Paging support.....	30
7.2.3.4	Positioning .....	30
7.2.3.5	NAS Node Selection Function .....	30
7.2.3.6	Shared Networks Access Control.....	30
7.2.3.7	GERAN System Information Retrieval.....	31
7.2.3.8	Enhanced SRNS Relocation.....	31
7.2.3.9	Subscriber Profile ID for RAT/Frequency Priority .....	31
7.2.4	Functions related to radio resource management and control.....	31
7.2.4.1	Radio resource configuration and operation .....	31
7.2.4.2	Radio environment survey .....	31
7.2.4.3	Combining/splitting control .....	32
7.2.4.4	Connection set-up and release.....	32
7.2.4.5	Allocation and deallocation of Radio Bearers.....	32
7.2.4.6	[TDD - Dynamic Channel Allocation (DCA)].....	32
7.2.4.7	Radio protocols function .....	33
7.2.4.8	RF power control .....	33
7.2.4.8.1	UL Outer Loop Power Control.....	33
7.2.4.8.2	DL Outer Loop Power Control.....	33
7.2.4.8.3	UL Inner Loop Power Control.....	33
7.2.4.8.4	DL Inner Loop Power Control.....	34
7.2.4.8.5	UL Open Loop Power Control .....	34
7.2.4.8.6	DL Open Loop Power Control .....	34
7.2.4.9	Radio channel coding .....	34
7.2.4.10	Radio channel decoding .....	34
7.2.4.11	Channel coding control .....	34
7.2.4.12	Initial (random) access detection and handling .....	34
7.2.4.13	CN Distribution function for Non Access Stratum messages .....	35
7.2.4.14	[3.84 Mcps and 7.68 Mcps TDD - Timing Advance] .....	35
7.2.4.15	Service specific function for Non Access Stratum messages.....	35
7.2.4.16	[1.28 Mcps TDD – Uplink Synchronisation] .....	35
7.2.5	Functions related to broadcast and multicast services (broadcast/multicast interworking function BM-IWF).....	35
7.2.5.1	Broadcast/Multicast Information Distribution .....	35
7.2.5.2	Broadcast/Multicast Flow Control .....	35
7.2.5.3	CBS Status Reporting .....	35
7.2.6	Tracing.....	36
7.2.7	Volume Reporting .....	36
7.2.8	RAN Information Management .....	36
7.2.9	Functions related to MBMS.....	36
7.2.9.1	MBMS provision.....	36
7.2.9.2	MBMS Notification Coordination .....	36
7.2.10	SIPTO at Iu-PS .....	36
7.2.11	Explicit Congestion Notification .....	36
7.2.12	MDT .....	36
8	Mobility Management .....	37
8.1	Signalling connection.....	37
8.2	Consequences for Mobility Handling.....	37
9	Synchronisation.....	37
9.1	SYNCHRONISATION MODEL.....	37
10	UTRAN O&M Requirements .....	38
10.1	O&M of Node B.....	38
10.1.1	Implementation Specific O&M.....	39
10.1.2	Logical O&M.....	39
11	UTRAN Interfaces .....	40

11.1	General Protocol Model for UTRAN Interfaces .....	40
11.1.1	General.....	40
11.1.2	Horizontal Layers .....	40
11.1.3	Vertical Planes .....	40
11.1.3.1	Control Plane.....	40
11.1.3.2	User Plane .....	41
11.1.3.3	Transport Network Control Plane .....	41
11.1.3.4	Transport Network User Plane .....	41
11.2	Protocol Model (Informative).....	42
11.2.1	RACH Transport Channel .....	42
11.2.2	CPCH [FDD] Transport Channel.....	43
11.2.3	FACH Transport Channel .....	43
11.2.4	DCH Transport Channel .....	44
11.2.5	DSCH Transport Channel [TDD] .....	45
11.2.6	USCH Transport Channel [TDD] .....	46
11.2.7	HS-DSCH Transport Channel.....	47
11.2.8	E-DCH Transport Channel .....	50
12	UTRAN Performance Requirements.....	52
12.1	UTRAN delay requirements.....	52
<b>Annex A (informative): SPID ranges and mapping of SPID values to cell reselection and inter-RAT/inter frequency handover priorities .....</b>		<b>53</b>
<b>Annex A2 (Informative): Deployment of Extended Identifiers.....</b>		<b>54</b>
A2.1	RNC Sizing Changes.....	54
A2.1.1	U-RNTI Considerations .....	54
A2.1.2	Extend S-RNTI and reduce RNC-ID: Solution 1.....	55
A2.1.3	Pooled RNCs: Solution 2.....	55
A2.2	RNC ID Extension.....	56
A2.2.1	Solution for RNC-ID Extension.....	56
A2.2.2	Rules for Configuration .....	57
A2.2.3	Configuration Example.....	60
<b>Annex B (informative): Change history .....</b>		<b>62</b>
History .....		64

---

# Foreword

This Technical Specification (TS) has been produced by the 3<sup>rd</sup> Generation Partnership Project (3GPP).

The contents of the present document are subject to continuing work within the TSG and may change following formal TSG approval. Should the TSG modify the contents of the present document, it will be re-released by the TSG with an identifying change of release date and an increase in version number as follows:

Version x.y.z

where:

- x the first digit:
  - 1 presented to TSG for information;
  - 2 presented to TSG for approval;
  - 3 or greater indicates TSG approved document under change control.
- y the second digit is incremented for all changes of substance, i.e. technical enhancements, corrections, updates, etc.
- z the third digit is incremented when editorial only changes have been incorporated in the document.

---

# 1 Scope

The present document describes the overall architecture of the UTRAN, including internal interfaces and assumptions on the radio and Iu interfaces.

---

# 2 References

The following documents contain provisions which, through reference in this text, constitute provisions of the present document.

- References are either specific (identified by date of publication, edition number, version number, etc.) or non-specific.
- For a specific reference, subsequent revisions do not apply.
- For a non-specific reference, the latest version applies. In the case of a reference to a 3GPP document (including a GSM document), a non-specific reference implicitly refers to the latest version of that document *in the same Release as the present document*.

- [1] Void
- [2] 3GPP TS 23.110: "UMTS Access Stratum Services and Functions".
- [3] Void
- [4] 3GPP TS 25.442: "UTRAN Implementation Specific O&M Transport".
- [5] 3GPP TS 25.402: "Synchronisation in UTRAN, Stage 2".
- [6] 3GPP TS 23.003: "Numbering, Addressing and Identification".
- [7] 3GPP TS 25.331: " Radio Resource Control (RRC); Protocol specification".
- [8] 3GPP TS 23.101: "General UMTS Architecture".
- [9] 3GPP TS 25.414: " UTRAN Iu Interface Data Transport & Transport Signalling".
- [10] 3GPP TS 25.424: "UTRAN Iur Interface Data Transport & Transport Signalling for Common Transport Channel Data Streams".
- [11] 3GPP TS 25.434: "UTRAN Iub Interface Data Transport & Transport Signalling for Common Transport Channel Data Streams".
- [12] IETF RFC 2460 (1998-12): "Internet Protocol, Version 6 (Ipv6) Specification".
- [13] Void
- [14] IETF RFC 768 (1980-08): "User Datagram Protocol".
- [15] "Information technology – Open Systems Interconnection – Network service definition", X.213, ISO/IEC 8348.
- [16] "Information technology – Open Systems Interconnection – Network service definition Amendment 1: Addition of the Internet protocol address format identifier", X.213/Amd.1, ISO/IEC 8348.
- [17] IETF RFC 791 (1981-09): "Internet Protocol".
- [18] 3GPP TS 25.426: "UTRAN Iur and Iub Interface Data Transport & Transport Signalling for DCH Data Streams".
- [19] Void



- [20] 3GPP TS 23.236: "Intra-domain connection of Radio Access Network (RAN) nodes to multiple Core Network (CN) nodes".
- [21] 3GPP TR 43.930: "Iur-g interface; Stage 2".
- [22] 3GPP TR 44.901: "External Network Assisted Cell Change".
- [23] 3GPP TS 48.018: "General Packet Radio Service (GPRS); BSS GPRS Protocol (BSSGP)".
- [24] 3GPP TS 25.460: "UTRAN Iuant Interface: General Aspects and Principles".
- [25] 3GPP TS 25.461: "UTRAN Iuant Interface: Layer 1".
- [26] 3GPP TS 25.462: "UTRAN Iuant Interface: Signalling Transport".
- [27] Void
- [28] 3GPP TS 23.251: "Network sharing - Architecture and functional description".
- [29] 3GPP TS 25.410: "UTRAN Iu Interface: general aspects and principles".
- [30] 3GPP TS 25.346: "Introduction of the Multimedia Broadcast Multicast Service (MBMS) in the Radio Access Network (RAN); Stage 2".
- [31] 3GPP TS 25.413: "UTRAN Iu Interface RANAP Signalling".
- [32] 3GPP TS 25.466: "UTRAN Iuant Interface: Application part".
- [33] 3GPP TS 25.305: "Stage 2 functional specification of UE positioning in UTRAN".
- [34] IETF RFC 4548 (2006-05): "Internet Code Point (ICP) Assignments for NSAP Addresses"
- [35] 3GPP TS 36.300: "Evolved Universal Terrestrial Radio Access (E-UTRA), Evolved Universal Terrestrial Radio Access Network (E-UTRAN); Overall description; stage 2".
- [36] 3GPP TS 23.060: "General Packet Radio Service (GPRS); Service description; Stage 2".
- [37] IETF RFC 3168 (2001-09): "The Addition of Explicit Congestion Notification (ECN) to IP".
- [38] 3GPP TS 37.320: "Universal Terrestrial Radio Access (UTRA) and Evolved Universal Terrestrial Radio Access (E-UTRA); Radio measurement collection for Minimization of Drive Tests (MDT); Overall description; Stage 2".

---

## 3 Definitions and abbreviations

### 3.1 Definitions

For the purposes of the present document, the following terms and definitions apply:

**[1.28Mcps TDD - Multi-frequency Cell]:** If multiple frequencies are configured in one cell, the cell is defined as the multi-frequency cell.]

**[1.28Mcps TDD - Primary frequency]:** In a multi-frequency cell, the frequency on which the P-CCPCH is transmitted is defined as primary frequency.]

**[1.28Mcps TDD - Secondary frequency]:** In a multi-frequency cell, any frequency other than the primary frequency is defined as secondary frequency.]

**ALCAP:** generic name for the transport signalling protocols used to set-up and tear-down transport bearers

**Cell:** Radio Network object that can be uniquely identified by a User Equipment from a (cell) identification that is broadcasted over a geographical area from one *UTRAN Access Point*  
A Cell is either FDD or TDD mode.

**Iu:** interface between an RNC and an MSC, SGSN or CBC, providing an interconnection point between the RNS and the Core Network. It is also considered as a reference point

**Iub:** interface between the RNC and the Node B

**Iur:** logical interface between two RNCs

Whilst logically representing a point to point link between RNCs, the physical realisation need not be a point to point link.

**Iur-g:** logical interface between RNC/BSS and BSS

Whilst logically representing a point to point link between RNC/BSS and BSS, the physical realisation need not be a point to point link.

**Logical Model:** Logical Model defines an abstract view of a network or network element by means of information objects representing network element, aggregations of network elements, the topological relationship between the elements, endpoints of connections (termination points), and transport entities (such as connections) that transport information between two or more termination points

The information objects defined in the Logical Model are used, among others, by connection management functions. In this way, a physical implementation independent management is achieved.

**Network sharing supporting UE:** as defined in TS 23.251 [28].

**Network sharing non-supporting UE:** as defined in TS 23.251 [28].

**Node B:** logical node in the RNS responsible for radio transmission / reception in one or more cells to/from the UE  
The logical node terminates the Iub interface towards the RNC.

**Radio Resources:** resources that constitute the radio interface in UTRAN, e.g. frequencies, scrambling codes, spreading factors, power for common and dedicated channels

**Node B Application Part:** Radio Network Signalling over the Iub

**Radio Network Controller:** logical node in the RNS in charge of controlling the use and the integrity of the radio resources

**Controlling RNC:** role an RNC can take with respect to a specific set of Node B's

There is only one Controlling RNC for any Node B. The Controlling RNC has the overall control of the logical resources of its node B's.

**MBMS Master RNC:** role an RNC can take with respect to one or more specific MBSFN cluster(s)

MRNC may be used for Inter-RNC MBSFN operation whenever dynamic synchronization of radio resources used for MBMS services is centrally controlled. There is only one MBMS Master RNC for any MBSFN cluster, which may control one or more MBSFN cluster(s). The MRNC has the overall control of the logical resources of the RNSs that are used for MBSFN operation within the MBSFN cluster(s).

**Radio Network Subsystem:** RNS can be either a full UTRAN or only a part of a UTRAN

An RNS offers the allocation and release of specific radio resources to establish means of connection in between an UE and the UTRAN. A Radio Network Subsystem contains one RNC and is responsible for the resources and transmission/reception in a set of cells.

**Serving RNS:** role an RNS can take with respect to a specific connection between an UE and UTRAN

There is one Serving RNS for each UE that has a connection to UTRAN. The Serving RNS is in charge of the radio connection between a UE and the UTRAN. The Serving RNS terminates the Iu for this UE.

**Drift RNS:** role an RNS can take with respect to a specific connection between an UE and UTRAN

An RNS that supports the Serving RNS with radio resources when the connection between the UTRAN and the UE need to use cell(s) controlled by this RNS is referred to as Drift RNS.

**Radio Access Network Application Part:** Radio Network Signalling over the Iu

**Radio Network Subsystem Application Part:** Radio Network Signalling over the Iur

**RRC Connection:** point-to-point bi-directional connection between RRC peer entities on the UE and the UTRAN sides, respectively

An UE has either zero or one RRC connection.

**Stand-Alone SMLC:** as defined in TS 25.305 [33].

**User Equipment:** Mobile Equipment with one or several UMTS Subscriber Identity Module(s)

A device allowing a user access to network services via the Uu interface. The UE is defined in ref. TS 23.101 [8]. If this term is used in the context of Iur-g, it means MS in case it uses radio resources of a DBSS.

**Universal Terrestrial Radio Access Network:** UTRAN is a conceptual term identifying that part of the network which consists of RNCs and Node Bs between Iu and Uu

The concept of UTRAN instantiation is currently undefined.

**User Datagram Protocol:** as defined in IETF RFC 768 [14].

**UTRAN Access Point:** conceptual point within the UTRAN performing radio transmission and reception

A UTRAN access point is associated with one specific *cell*, i.e. there exists one UTRAN access point for each cell. It is the UTRAN-side end point of a *radio link*.

**Radio Link:** "radio link" is a logical association between a single User Equipment and a single UTRAN access point. Its physical realisation comprises one or more radio bearer transmissions.

**Radio Link Set:** set of one or more Radio Links that has a common generation of Transmit Power Control (TPC) commands in the DL

**Uu:** Radio interface between UTRAN and the User Equipment

**RAB sub-flows:** Radio Access Bearer can be realised by UTRAN through several sub-flows

These sub-flows correspond to the NAS service data streams that have QoS characteristics that differ in a predefined manner within a RAB e.g. different reliability classes.

RAB sub-flows have the following characteristics:

- 1) The sub-flows of a RAB are established and released at the RAB establishment and release, respectively.
- 2) The sub-flows of a RAB are submitted and delivered together at the RAB SAP.
- 3) The sub-flows of a RAB are carried over the same Iu transport bearer.
- 4) The sub-flows of a RAB are organised in a predefined manner at the SAP and over the Iu interface. The organisation is imposed by the NAS as part of its co-ordination responsibility.

**Set of co-ordinated DCHs:** set of co-ordinated DCHs is a set of dedicated transport channels that are always established and released in combination

Individual DCHs within a set of co-ordinated DCHs cannot be operated on individually e.g. if the establishment of one DCH fails, the establishment of all other DCHs in the set of co-ordinated DCHs shall be terminated unsuccessfully. A set of coordinated DCHs is transferred over one transport bearer. All DCHs in a set of co-ordinated DCHs shall have the same TTI.

**Shared Network Area (SNA):** Area consisting of one or more LA's to which access can be controlled.

## 3.2 Abbreviations

For the purposes of the present document, the following abbreviations apply:

AAL	ATM Adaptation Layer
AAL2	ATM Adaptation Layer 2
ALCAP	Access Link Control Application Part
APN	Access Point Name
ATM	Asynchronous Transfer Mode
BM-IWF	Broadcast Multicast Interworking Function
BMC	Broadcast/Multicast Control
BSS	Base Station Subsystem

CBC	Cell Broadcast Centre
CBS	Cell Broadcast Service
CN	Core Network
CRNC	Controlling Radio Network Controller
DCH	Dedicated Channel
DL	Downlink
DRNS	Drift RNS
DSP	Domain Specific Part
EAB	Extended Access Barring
E-DCH	Enhanced UL DCH
EDGE	Enhanced Data rates for Global Evolution
FACH	Forward Access Channel
FFS	For Further Study
GERAN	GSM EDGE Radio Access Network
GSM	Global System for Mobile Communications
GTP	GPRS Tunnelling Protocol
GWCN	GateWay Core Network
HPLMN	Home PLMN
IDP	Initial Domain Part
IPv4	Internet Protocol, version 4
IPv6	Internet Protocol, version 6
LA	Location Area
MAC	Medium Access Control
MBMS	Multimedia Broadcast Multicast Service
MCCH	MBMS point-to-multipoint Control Channel
MDT	Minimization of Drive-Tests
MOCN	Multi Operator Core Network
MRNC	MBMS Master Radio Network Controller
MSCH	MBMS point-to-multipoint Scheduling Channel
MTCH	MBMS point-to-multipoint Traffic Channel
NACC	Network Assisted Cell Change
NAS	Non Access Stratum
NBAP	Node B Application Part
NNSF	NAS Node Selection Function
NSAP	Network Service Access Point
PCH	Paging Channel
PLMN	Public Land Mobile Network
PTM	Point To Multipoint
PTP	Point To Point
QoS	Quality of Service
RAB	Radio Access Bearer
RACH	Random Access Channel
RANAP	Radio Access Network Application Part
RET	Remote Electrical Tilting
RIM	RAN Information Management
RNC	Radio Network Controller
RNL	Radio Network Layer
RNS	Radio Network Subsystem
RNSAP	Radio Network Subsystem Application Part
RNTI	Radio Network Temporary Identity
SAB	Service Area Broadcast
SAS	Stand-Alone SMLC
SIPTO	Selected IP Traffic Offload
SMLC	Serving Mobile Location Centre
SNA	Shared Network Area
SRNC	Serving Radio Network Controller
SRNS	Serving RNS
TMA	Tower Mounted Amplifier
TBSS	Target BSS
TEID	Tunnel Endpoint Identifier
TMGI	Temporary Mobile Group Identity
TNL	Transport Network Layer

TTI	Transmission Time Interval
UDP	User Datagram Protocol
UE	User Equipment
UL	Uplink
UMTS	Universal Mobile Telecommunication System
URA	UTRAN Registration Area
USIM	UMTS Subscriber Identity Module
UTRAN	Universal Terrestrial Radio Access Network

### 3.3 Notation

For the purposes of the present document, the following notations apply:

[FDD]	This tagging of a word indicates that the word preceding the tag "[FDD]" applies only to FDD. This tagging of a heading indicates that the heading preceding the tag "[FDD]" and the section following the heading applies only to FDD.
[TDD]	This tagging of a word indicates that the word preceding the tag "[TDD]" applies only to TDD, including 3.84Mcps TDD, 7.68Mcps TDD and 1.28Mcps TDD. This tagging of a heading indicates that the heading preceding the tag "[TDD]" and the section following the heading applies only to TDD, including 3.84Mcps TDD, 7.68Mcps TDD and 1.28Mcps TDD.
[3.84Mcps TDD]	This tagging of a word indicates that the word preceding the tag "[3.84Mcps TDD]" applies only to 3.84Mcps TDD. This tagging of a heading indicates that the heading preceding the tag "[3.84Mcps TDD]" and the section following the heading applies only to 3.84Mcps TDD.
[1.28Mcps TDD]	This tagging of a word indicates that the word preceding the tag "[1.28Mcps TDD]" applies only to 1.28Mcps TDD. This tagging of a heading indicates that the heading preceding the tag "[1.28Mcps TDD]" and the section following the heading applies only to 1.28Mcps TDD.
[7.68Mcps TDD]	This tagging of a word indicates that the word preceding the tag "[7.68Mcps TDD]" applies only to 7.68Mcps TDD. This tagging of a heading indicates that the heading preceding the tag "[7.68Mcps TDD]" and the section following the heading applies only to 7.68Mcps TDD.
[FDD - ...]	This tagging indicates that the enclosed text following the "[FDD - " applies only to FDD. Multiple sequential paragraphs applying only to FDD are enclosed separately to enable insertion of TDD specific (or common) paragraphs between the FDD specific paragraphs.
[TDD - ...]	This tagging indicates that the enclosed text following the "[TDD - " applies only to TDD including 3.84Mcps TDD, 7.68Mcps TDD and 1.28Mcps TDD. Multiple sequential paragraphs applying only to TDD are enclosed separately to enable insertion of FDD specific (or common) paragraphs between the TDD specific paragraphs.
[3.84Mcps TDD - ...]	This tagging indicates that the enclosed text following the "[3.84Mcps TDD - " applies only to 3.84Mcps TDD. Multiple sequential paragraphs applying only to 3.84Mcps TDD are enclosed separately to enable insertion of FDD and TDD specific (or common) paragraphs between the 3.84Mcps TDD specific paragraphs.
[1.28Mcps TDD - ...]	This tagging indicates that the enclosed text following the "[1.28Mcps TDD - " applies only to 1.28Mcps TDD. Multiple sequential paragraphs applying only to 1.28Mcps TDD are enclosed separately to enable insertion of FDD and TDD specific (or common) paragraphs between the 1.28Mcps TDD specific paragraphs.
[7.68Mcps TDD - ...]	This tagging indicates that the enclosed text following the "[7.68Mcps TDD - " applies only to 7.68Mcps TDD. Multiple sequential paragraphs applying only to 7.68Mcps TDD are enclosed separately to enable insertion of FDD and TDD specific (or common) paragraphs between the 7.68Mcps TDD specific paragraphs.
Message	When referring to a message in the specification, the MESSAGE NAME is written with all letters in upper case characters followed by the word "message", e.g. RADIO LINK SETUP REQUEST message.

IE	When referring to an information element (IE) in the specification, the <i>Information Element Name</i> is written with the first letters in each word in upper case characters and all letters in <i>Italic font</i> followed by the abbreviation "IE", e.g. <i>Transport Format Set IE</i> .
Value of an IE	When referring to the value of an information element (IE) in the specification, the "Value" is enclosed by quotation marks, e.g. "Abstract Syntax Error (Reject)".
Frame	When referring to a control or data frame in the specification, the CONTROL/DATA FRAME NAME is written with all letters in upper case characters followed by the words "control/data frame", e.g. FACH FLOW CONTROL control frame.

---

## 4 General principles

The general principles guiding the definition of UTRAN Architecture as well as the UTRAN interfaces are the following:

- Logical separation of signalling and data transport networks.
- UTRAN and CN functions are fully separated from transports functions. Addressing scheme used in UTRAN and CN shall not be tied to the addressing schemes of transport functions. The fact that some UTRAN or CN function resides in the same equipment as some transport functions does not make the transport functions part of the UTRAN or the CN.
- [FDD - Macro diversity is fully handled in the UTRAN.]
- Mobility for RRC connection is fully controlled by the UTRAN.
- When defining the UTRAN interfaces the following principles were followed: The functional division across the interfaces shall have as few options as possible.
- Interfaces should be based on a logical model of the entity controlled through this interface.
- One Physical Network Element can implement multiple Logical Nodes.

Transport Network Control Plane is a functional plane in the interfaces protocol structure that is used for the transport bearer management. The actual signalling protocol that is in use within the Transport Network Control Plane depends on the underlying transport layer technology. The intention is not to specify a new UTRAN specific Application Part for the Transport Network Control Plane but to use signalling protocols standardised in other groups (if needed) for the applied transport layer technology.

---

## 5 UMTS General architecture

### 5.1 Overview

Figure 1 shows a simplified UMTS architecture with the external reference points and interfaces to the UTRAN.

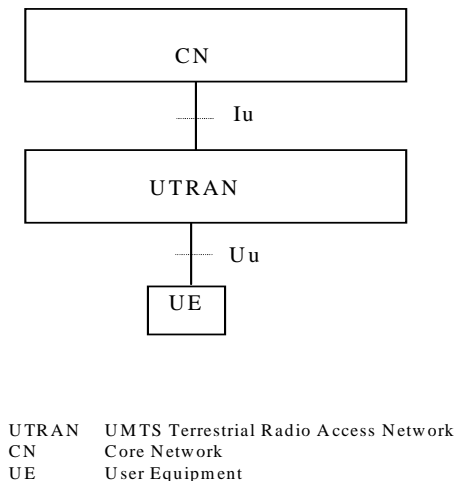

Figure 1: UMTS Architecture

## 5.2 General protocols architecture

The protocols over Uu and Iu interfaces are divided into two structures:

- **User plane protocols**  
These are the protocols implementing the actual radio access bearer service, i.e. carrying user data through the access stratum.
- **Control plane protocols**  
These are the protocols for controlling the radio access bearers and the connection between the UE and the network from different aspects (including requesting the service, controlling different transmission resources, handover & streamlining etc.). Also a mechanism for transparent transfer of NAS messages is included.

### 5.2.1 User plane

The radio access bearer service is offered from SAP to SAP by the Access Stratum. Figure 2 shows the protocols on the Uu and Iu interfaces that linked together provide this radio access bearer service.

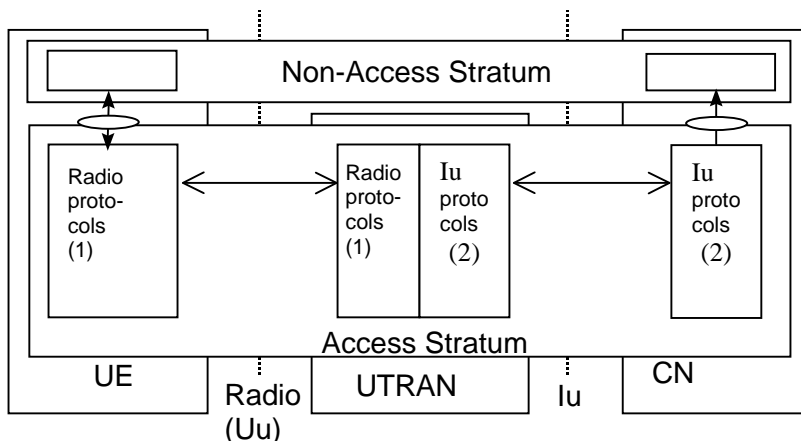

- (1) The radio interface protocols are defined in documents TS 25.2xx and TS 25.3xx.
- (2) The Iu interface protocols are defined in documents TS 25.41x.

Figure 2: Iu and Uu User plane

## 5.2.2 Control plane

Figure 3 shows the control plane (signalling) protocol stacks on Iu and Uu interfaces.

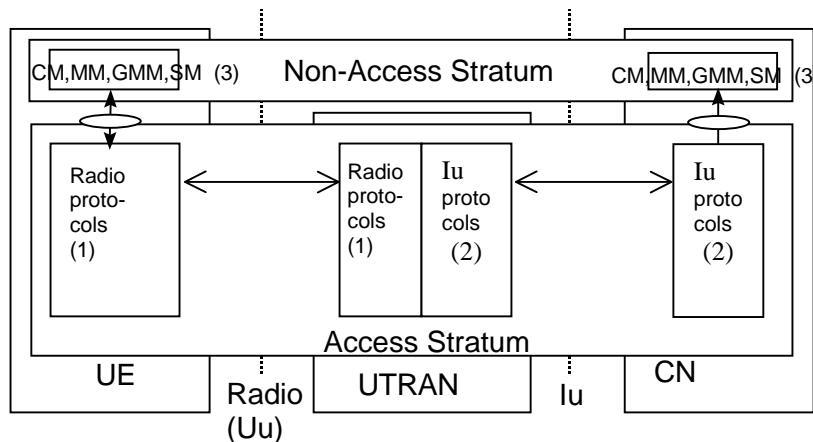

- (1) The radio interface protocols are defined in documents TS 25.2xx and TS 25.3xx.
- (2) The protocol is defined in documents TS 25.41x. (Description of Iu interface).
- (3) **CM, MM, GMM, SM:** This exemplifies a set of NAS control protocols between UE and CN. There may be different NAS protocol stacks in parallel. The evolution of the protocol architecture for these protocols is outside the scope of the present document.

**Figure 3: Iu and Uu Control plane**

NOTE: Both the Radio protocols and the Iu protocols contain a mechanism to transparently transfer NAS messages.

## 6 UTRAN Architecture

The UTRAN consists of a set of Radio Network Subsystems connected to the Core Network through the Iu.

A RNS consists of a Radio Network Controller one or more Node Bs and optionally one SAS. A Node B is connected to the RNC through the Iub interface.

A Node B can support FDD mode, TDD mode or dual-mode operation.

There are three chip-rate options in the TDD mode: 7.68 Mcps TDD, 3.84 Mcps TDD and 1.28 Mcps TDD. Each TDD cell supports one of these options.

A Node B which supports TDD cells can support one chip-rate option only, or more than one option.

A RNC which supports TDD cells can support one chip-rate option only, or more than one option.

The RNC is responsible for the Handover decisions that require signalling to the UE.

A RNC may include a combining/splitting function to support combination/splitting of information streams (see subclause 7.2.4.3).

Inside the UTRAN, the RNCs of the Radio Network Subsystems can be interconnected together through the Iur. Iu(s) and Iur are logical interfaces. Iur can be conveyed over direct physical connection between RNCs or virtual networks using any suitable transport network.

The UTRAN architecture is shown in figure 4.



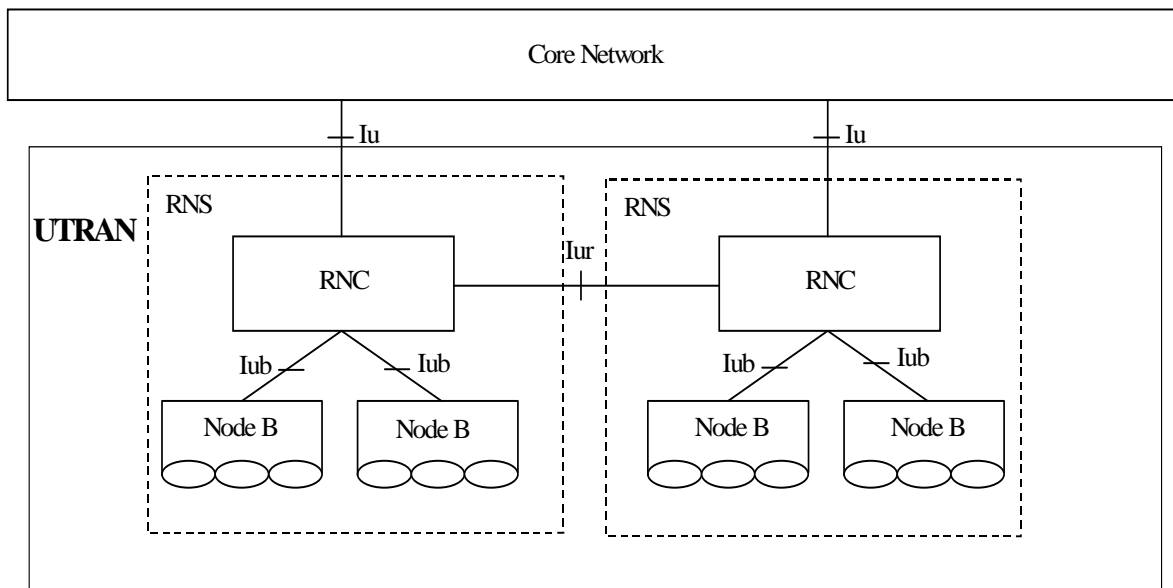

**Figure 4: UTRAN Architecture**

Regarding the UE positioning method, the RNC may have full internal support for this function and/or may be connected to one SAS via the Iupc interface. The following picture illustrates the resulting UTRAN architecture when the Iupc interface is adopted.

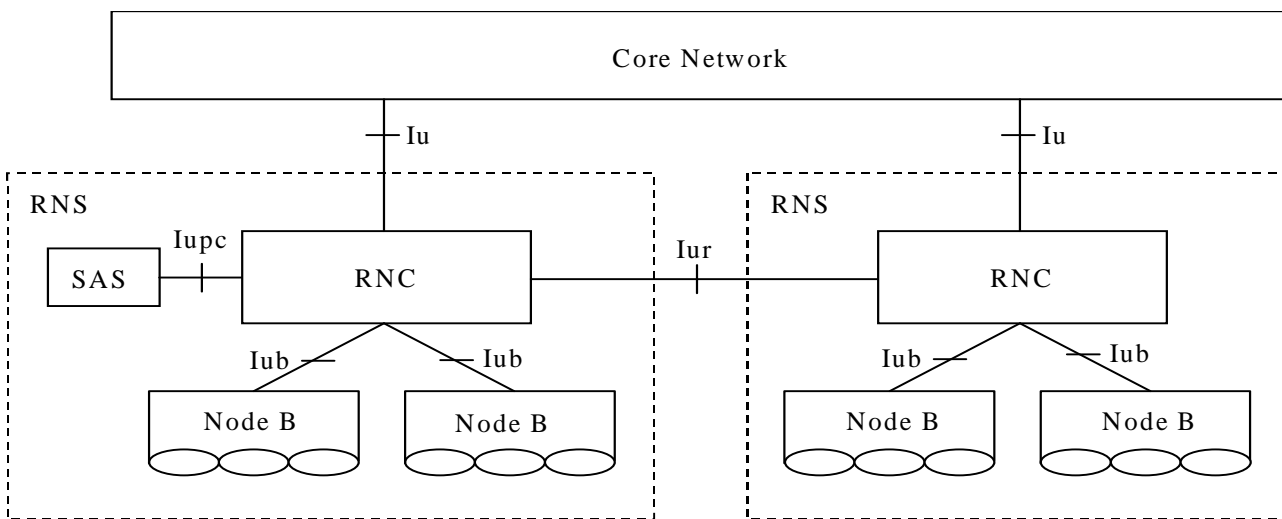

**Figure 4a: UTRAN Architecture with the Iupc option**

The RNC may be connected to BSS supporting GERAN Iu mode via the Iur-g interface. The following picture illustrates the UTRAN and GERAN Iu mode connection when the Iur-g interface is adopted. For 1.28Mcps TDD, the RNC may be connected to BSS supporting GERAN A/Gb mode via the Iur-g interface. The figure 4c illustrates the UTRAN and GERAN A/Gb mode connection when the Iur-g interface is adopted for 1.28Mcps TDD.

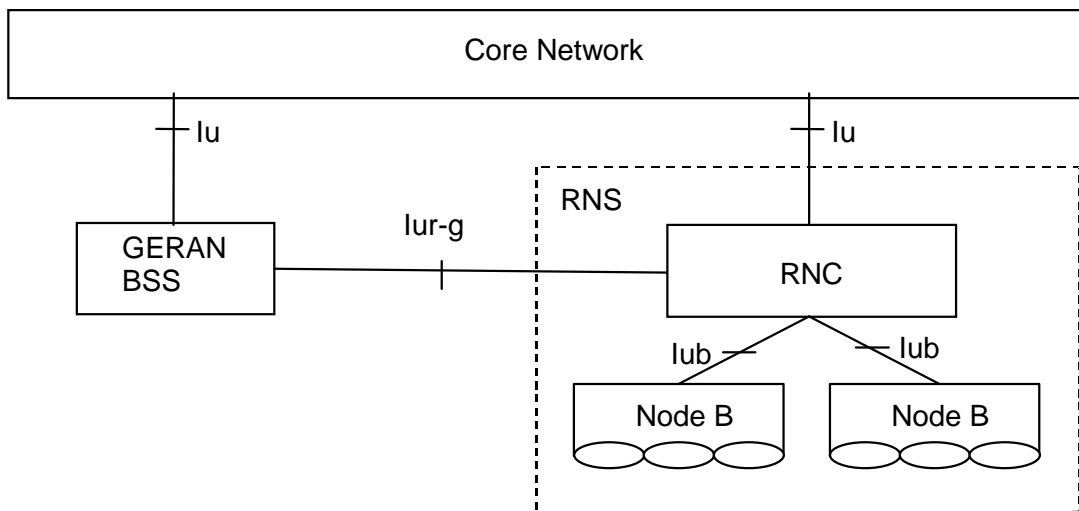

Figure 4b: UTRAN and GERAN Iu mode connection with Iur-g

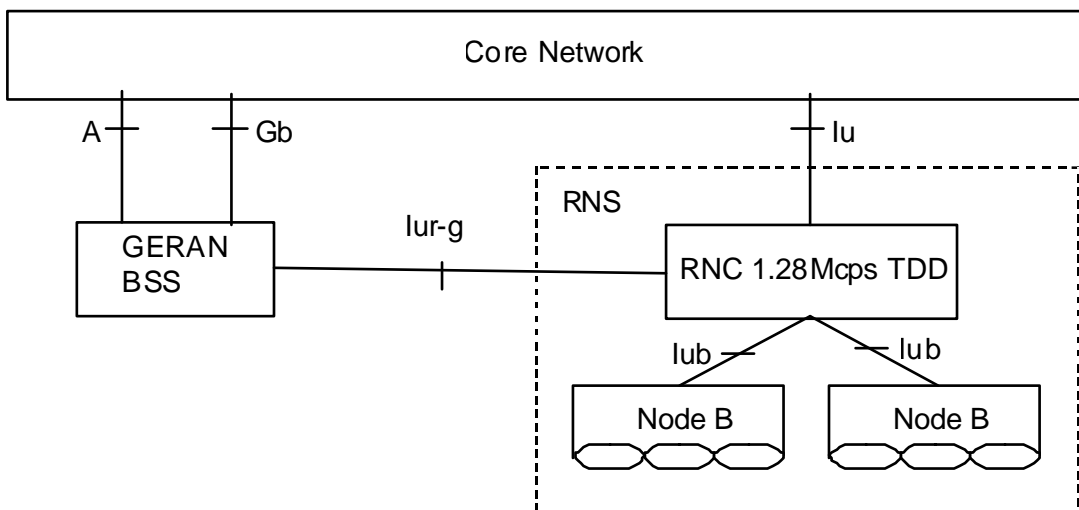

Figure 4c: UTRAN and GERAN A/Gb mode connection with Iur-g for 1.28Mcps TDD

Each RNS is responsible for the resources of its set of cells.

For each connection between User Equipment and the UTRAN, One RNS is the Serving RNS. When required, Drift RNSs support the Serving RNS by providing radio resources as shown in figure 5. The role of an RNS (Serving or Drift) is on a per connection basis between a UE and the UTRAN.

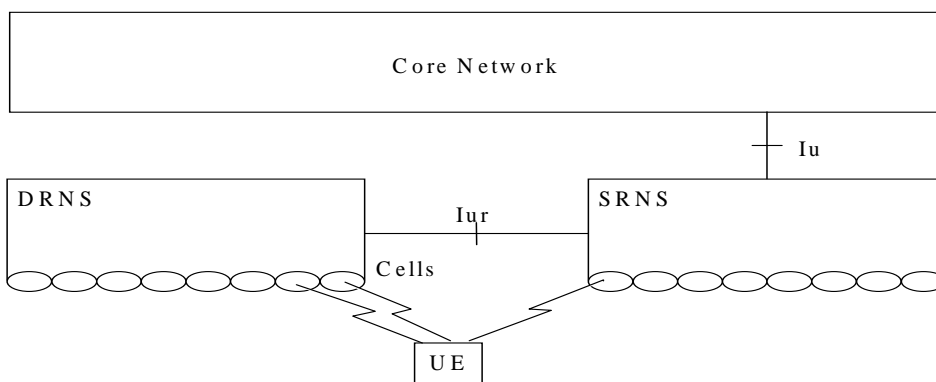
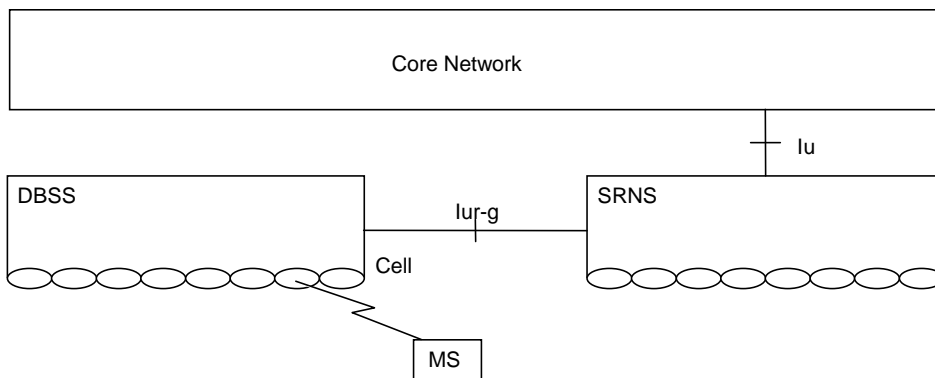

Figure 5: Serving and Drift RNS

To support UE mobility between UTRAN and GERAN Iu mode, the Serving RNS may be connected to the DBSS and vice versa as illustrated in figures 5a and 5b. For 1.28Mcps TDD, to support UE mobility between UTRAN and

GERAN A/Gb mode, the Serving RNS may be connected to the TBSS as illustrated in figure 5c. The role of an RNS or BSS (Serving or Drift) is on a per connection basis between a UE and the UTRAN/GERAN Iu mode, or between a UE and the UTRAN /GERAN A/Gb mode for 1.28Mcp TDD.



**Figure 5a: Serving RNS and Drift BSS, GERAN Iu mode**

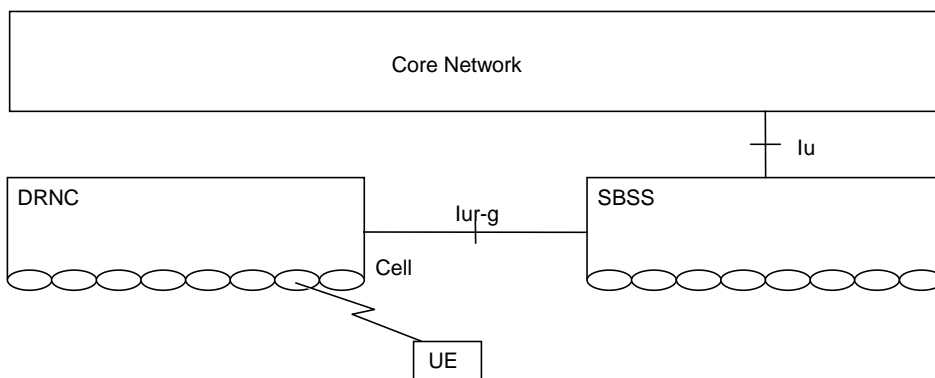

**Figure 5b: Serving BSS and Drift RNS, GERAN Iu mode**

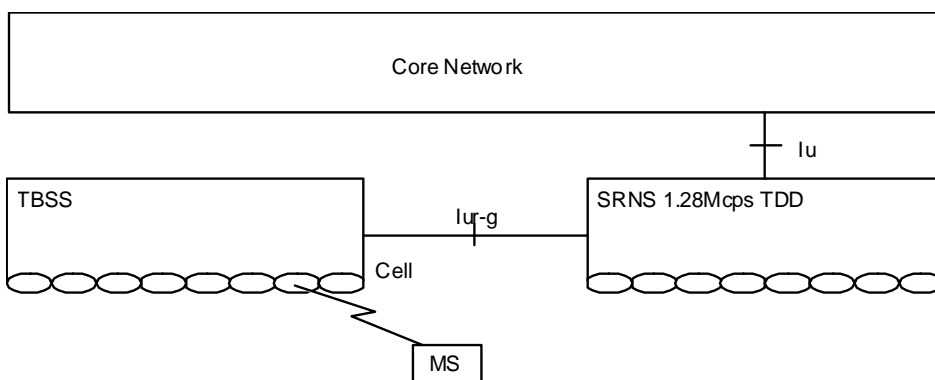

**Figure 5c: Serving RNS and Target BSS, GERAN A/Gb mode**

The UTRAN is layered into a Radio Network Layer and a Transport Network Layer.

The UTRAN architecture, i.e. the UTRAN logical nodes and interfaces between them, are defined as part of the Radio Network Layer.

For each UTRAN interface (Iu, Iur, Iub, Iupc) the related transport network layer protocol and functionality is specified. The transport network layer provides services for user plane transport, signalling transport and transport of implementation specific O&M.

An implementation of equipment compliant with the specifications of a certain interface shall support the Radio Network Layer protocols specified for that interface. It shall also as a minimum, for interoperability, support the transport network layer protocols according to the transport network layer specifications for that interface.

The network architecture of the transport network layer is not specified by 3GPP and is left as an operator issue.

The equipment compliant to 3GPP standards shall at least be able to act as endpoints in the transport network layer, and may also act as a switch/router within the transport network layer.

For implementation specific O&M signalling to the Node B, only the transport network layer protocols are in the scope of UTRAN specifications.

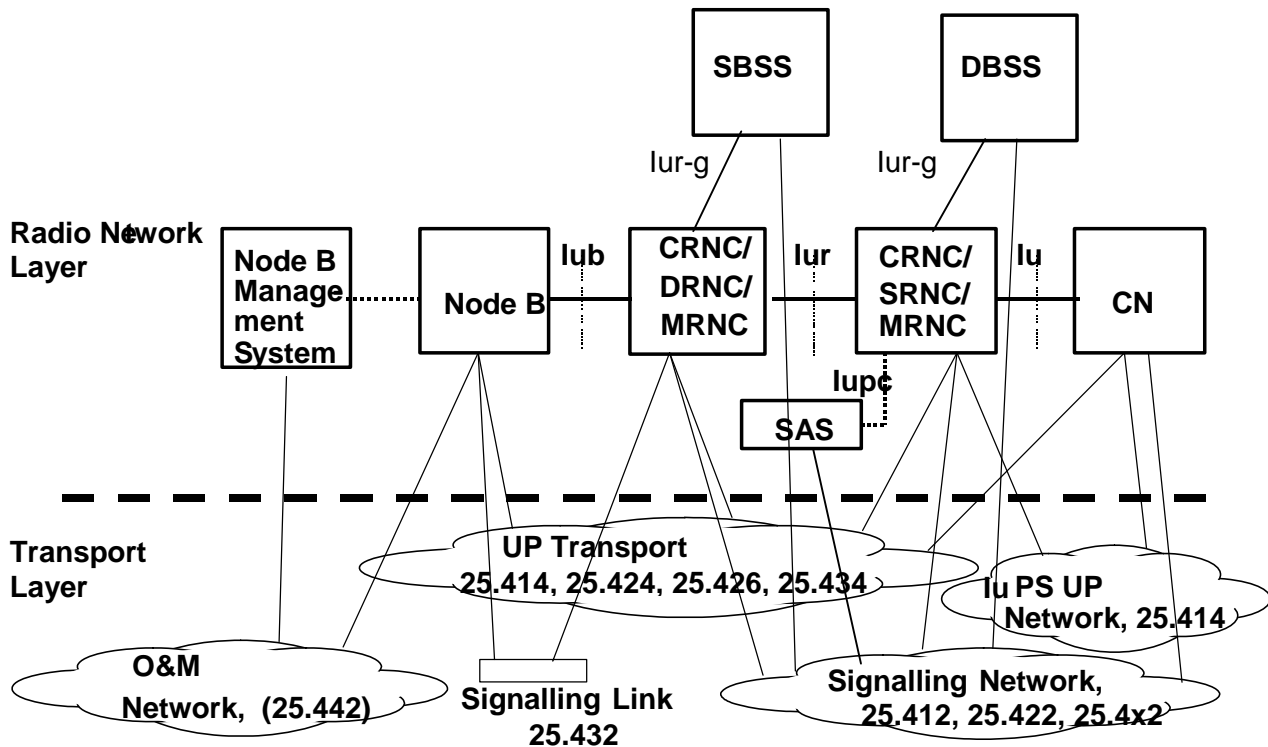

**Figure 6: Protocol layering**

Figure 6 illustrates which parts of the transport network layer that may be (but are not mandated to be) configured by the operator as transport networks, i.e. the radio network layer provides a destination address, namely:

- Transport network for implementation specific O&M traffic;
- Signalling network for Iu, Iur, Iur-g and Iupc;
- Transport network for Iub, Iur and Iu CS user plane connections;
- Transport network for Iu PS user plane connections.

The signalling link for Iub signalling as seen by the radio network layer cannot be configured as a network (no address provided).

A transport network for UTRAN may be configured by the operator to be used also for other traffic than UTRAN traffic.

## 6.1 UTRAN Identifiers

### 6.1.1 PLMN Identity

A Public Land Mobile Network is uniquely identified as defined in TS 23.003 [6] subclause 12.1.

### 6.1.2 CN Domain Identifier

A CN Domain Edge Node is identified as defined in TS 23.003 [6] sub-clause 12.2.

### 6.1.3 RNC Identifier

An RNC node is uniquely identified by its RNC Identifier among the nodes in UTRAN and GERAN Iu mode as defined in TS 23.003 [6] sub-clause 12.3. A BSS node in GERAN Iu mode is uniquely identified by its RNC Identifier among the nodes in GERAN Iu mode and UTRAN.

### 6.1.4 Service Area Identifier

The Service Area Identifier (SAI) is defined in TS 23.003 [6] sub-clause 12.4.

### 6.1.5 Cell Identifier

The Cell identifier (C-Id) is used to uniquely identify a cell within an RNS/BSS. The Cell-Id together with the identifier of the controlling RNC/BSS (CRNC-Id) constitutes the UTRAN/GERAN Cell Identity (UC-Id) and is used to identify the cell uniquely within UTRAN/GERAN Iu mode. UC-Id or C-Id is used to identify a cell in UTRAN Iub and Iur interfaces or Iur-g interface.

- **UC-Id = RNC-Id + C-Id.**

The C-Id is defined by the operator, and set in the RNC/BSS via O&M. The C-Id is set in a Node B by its C-RNC or in the GERAN Iu mode cell.

### 6.1.6 Local Cell Identifier

The Local Cell identifier is used to uniquely identify the set of resources within a Node B required to support a cell (as identified by a C-Id). As a minimum it shall be unique within the Node B, but it is also capable of supporting uniqueness within the UTRAN for management system purposes.

The Local Cell Identifier is used for the initial configuration of a Node B when no C-Id is defined. The Local Cell identifier is defined by the operator, and set in both the Node B and its C-RNC via O&M. The relationship between the Local Cell Identifier and C-Id is set in the C-RNC via O&M.

### 6.1.7 UE Identifiers

Radio Network Temporary Identities (RNTI) are used as UE identifiers within UTRAN/GERAN Iu mode and in signalling messages between UE and UTRAN/GERAN Iu mode.

Six types of RNTI exist:

- 1) Serving RNC/BSS RNTI (s-RNTI);
- 2) Drift RNC/BSS RNTI (d-RNTI);
- 3) Cell RNTI (c-RNTI);
- 4) UTRAN/GERAN RNTI (u-RNTI);
- 5) [TDD – DSCH RNTI (DSCH-RNTI)];
- 6) HS-DSCH RNTI (HS-DSCH RNTI);

## 7) E-DCH RNTI (E-RNTI);

**s-RNTI is used:**

- by UE to identify itself to the Serving RNC/BSS;
- by SRNC/SBSS to address the UE/MS;
- by DRNC/DBSS to identify the UE to Serving RNC.

s-RNTI is allocated for all UEs having a RRC connection, it is allocated by the Serving RNC/BSS and it is unique within the Serving RNC/BSS. s-RNTI is reallocated always when the Serving RNC/BSS for the RRC connection is changed.

**d-RNTI is used:**

- by serving RNC/BSS to identify the UE to Drift RNC/BSS.

NOTE: The d-RNTI is never used on Uu.

d-RNTI is allocated by drift RNC/BSS upon drift UE contexts establishment and it shall be unique within the drift RNC/BSS. Serving RNC/BSS shall know the mapping between s-RNTI and the d-RNTIs allocated in Drift RNCs/BSSs for the same UE. Drift RNC/BSS shall know the s-RNTI and SRNC-ID related to existing d-RNTI within the drift RNC/BSS.

**c-RNTI is used:**

- by UE to identify itself to the controlling RNC;
- by controlling RNC to address the UE.

c-RNTI is allocated by controlling RNC upon UE accessing a new cell. C-RNTI shall be unique within the accessed cell. Controlling RNC shall know the d-RNTI associated to the c-RNTI within the same logical RNC (if any).

**u-RNTI**

The u-RNTI is allocated to an UE having a RRC connection and identifies the UE within UTRAN/GERAN Iu mode.

u-RNTI is composed of:

- SRNC identity;
- s-RNTI.

**[TDD – DSCH-RNTI is used:]**

- [TDD – by controlling RNC to address the UE on the DSCH and USCH].

[TDD – DSCH-RNTI is allocated by controlling RNC upon UE establishing a DSCH or USCH channel. DSCH-RNTI shall be unique within the cell carrying the DSCH and/or USCH. DSCH-RNTI is used as UE identifier in RRC messages concerning DSCH and USCH allocations and is used in both the downlink and uplink.

**HS-DSCH RNTI is used:**

- for the UE specific CRC in HS-SCCH and HS-PDSCH.

HS-DSCH RNTI is allocated by controlling RNC upon UE establishing a HS-DSCH channel. HS-DSCH RNTI shall be unique within the cell carrying the HS-DSCH.

**E-RNTI is used:**

- for the UE[FDD - /UE group] specific CRC in E-AGCH.

E-DCH RNTI is allocated by NodeB upon UE establishing an E-DCH channel. E-DCH RNTI allocated to a UE [FDD - /UE group] shall be unique within the cell carrying the E-DCH.

Each RNC has a unique identifier within the UTRAN part of the PLMN, denoted by RNC identifier (RNC-ID). This identifier is used to route UTRAN interface messages to correct RNC. RNC-ID of the serving RNC together with the s-RNTI is a unique identifier of the UE in the UTRAN part of the PLMN.

### 6.1.7.1 Usage of RNTI

u-RNTI is used as a UE identifier for the first cell access (at cell change) when a RRC connection exists for this UE and for UTRAN originated paging including associated response messages. RNC-ID is used by Controlling RNC/BSS to route the received uplink messages towards the Serving RNC/BSS.

NOTE: For the initial access a unique core network UE identifier is used.

c-RNTI is used as a UE identifier in all other DCCH/DTCH common channel messages on air interface.

### 6.1.7a UE Identifiers in GERAN A/Gb mode (1.28Mcps TDD)

Radio Network Temporary Identity (RNTI) is used as a UE identifier within UTRAN /GERAN A/Gb mode and in signalling messages between UE and UTRAN /GERAN A/Gb mode. One type of RNTI exists:

- Drift RNTI (D-RNTI)

The D-RNTI is allocated by the TBSS and is used to identify the UE during a handover via the Iur-g interface.

There is one possible scenario in which the D-RNTI is used:

- a) The serving RAN node is a UTRAN RNC and the target RAN node is a GERAN BSS in A/Gb mode.

## 6.1.8 Identifiers for dedicated resources within UTRAN

### 6.1.8.1 Radio Network Control Plane identifiers

Each addressable object in each reference point has an application part level identifier. This identifier is allocated autonomously by the entity responsible for initiation of the setup of the object. This application part identifier will be used as a reference to the object that is setup. Both ends of the reference point shall memorise the AP Identifier during the lifetime of the object. Application part identifier can be related to a specific Transport Network identifier and that relationship shall also be memorised by both ends.

Table 1 lists the basic AP level identifiers in each reference point.

**Table 1: Basic AP level identifiers in each reference point**

Object	Identifier	Abbreviation	Valid for
Radio Access Bearer	Radio Access Bearer ID	RAB-ID	Iu
Dedicated Transport channel	DCH-ID	DCH-ID	Iur, Iub
[TDD – Downlink Shared Channel]	DSCH-ID	DSCH-ID	Iur, Iub
[TDD – Uplink Shared Channel]	USCH-ID	USCH-ID	Iur, Iub

### 6.1.8.2 Transport Network Identifiers

Transport Network identifiers are used in the Transport Network Layer (TNL) to identify the transport bearer and may be used in User Plane in the actual data transmission using the transport link. The Transport Network identifier identifies the transport link according to the naming conventions defined for the transport link type in question. Both ends of the reference point of the concerned TNL shall memorise the Transport Network identifiers during the lifetime of the transport link. Each Transport Network identifier can be binded to an Application Part identifier.

The Transport Network identifiers vary depending on the transport link type.

Table 2 indicates examples of the identifiers used for different transmission link types.

**Table 2: Examples of the identifiers used for different transmission link types**

Transmission link type	Transport Network Identifier
AAL2	AAL2 Path ID + CID
GTP over IP	IP address + TEID
UDP over IP	IP address + UDP port

The communication of Transport Network identifiers is made in two ways:

When an ALCAP is used, the transport layer address communicated via the Radio Network Layers protocols (NBAP, RNSAP, RANAP...) is a Transport Network Control Plane address and the Transport Network identifiers are communicated through this Transport Network Control Plane only.

When no ALCAP is used, the Transport Network identifiers are directly communicated via the Radio Network Layers protocols (NBAP, RNSAP, RANAP...) on all interfaces.

In both cases, the transport layer address (e.g. IP address) is encapsulated by the Transport Network Layer in the NSAP structure as defined in [Annex A of X.213, ISO/IEC 8348 [15], X.213/Amd. 1, ISO/IEC 8348 [16]] transported transparently on Iub, Iur and Iu-CS and passed transparently from the Radio Network Layer to the Transport Network Layer. The NSAP structure (encapsulation) is only used in order to provide to the TNL explicit identification of the type of the TNL address that is being conveyed by the given RNL protocol. It is then the responsibility of the Transport Network Layer to interpret this structure (e.g. to determine accordingly if the requested network type is ATM or IP).

On the Iu-PS, the NSAP structure is not used in RANAP but the 'straight IP addressing' shall be used.

The following scheme depicts the encapsulation of a native IPv6 (IETF RFC 2460 [12]) address in NSAP structure when conveyed in RANAP, RNSAP and NBAP.

Octet 1	octet 2	octet 3	octet 4
AFI=35 (IANA)	ICP=0 (embedded IPv6)		IPv6 (byte 1)
IPv6 (bytes 2-5)			
IPv6 (bytes 6-9)			
IPv6 (bytes 10-13)			
IPv6 (bytes 14-16)			0 0 0 0 0 0 0 0

**Figure 6A: IPv6 address embedded in NSAP structure in RANAP/RNSAP/NBAP.**

Note 1: The last octet of the DSP (the DSP is the remaining octets after the IDP IETF RFC 4548 [34]) the encapsulation of a native IPv6 address in NSAP structure is unspecified.

Note 2: The encapsulation of a native IPv4 address in NSAP structure when conveyed in RANAP, RNSAP and NBAP shall be encoded according to IETF RFC 4548 [34]. The last 13 octets of the DSP are unspecified.

Note 3: The default values for the unspecified octets are zero.

### 6.1.8.3 Binding identifier

Binding Identifier (Binding ID) is used to initialise the linkage between ALCAP and Application Part (RANAP, RNSAP, NBAP) identifiers. Binding identifier can be used both in Radio Network Control plane Application Part protocols and in Transport Network Control Plane's ALCAP protocol. When no ALCAP is used, Binding ID may also be used to carry the UDP port on Iub, Iur and Iu-CS interfaces.

Binding ID binds the Radio and Transport Network Control plane identifiers together. To ensure maximal independence of those two planes, the binding ID should be used only when necessary: Binding ID shall thus be used only in Radio Network Control plane Application Part messages in which a new association between the planes is created and in ALCAP messages creating new transport bearers.

Binding ID for each transport bearer shall be allocated before the setup of that transport bearer.



The Binding ID is sent on one direction using the Application Part protocol and is return in the other direction by the ALCAP protocol.

When an Application Part procedure with an allocated Binding ID is applied for modifying an existing Radio Network User Plane connection, the decision to use the Binding ID (and the ALCAP procedures) shall be done by that end of the reference point that decides whether to use the existing transport bearer or to set up a new transport bearer.

The Binding ID shall already be assigned and tied to a radio application procedure when the first ALCAP message is received in a node.

The association between the connection Id in the Application Part protocol (e.g. identifying a RAB) and the corresponding connection Id in the ALCAP protocol (e.g. identifying the AAL2 channel for that RAB) that was created with the help of Binding ID shall be memorised by both peers of each reference point for the lifetime of the corresponding transport bearer.

The Binding ID may be released and re-used as soon as both the Application Part procedure and the ALCAP procedure that used it are completed in both peers of the reference point.

Figure 6a illustrates how application instances of the Radio Network Control Plane and instances of the Transport Network Plane are linked together through the Binding Identifier in the set-up phase.

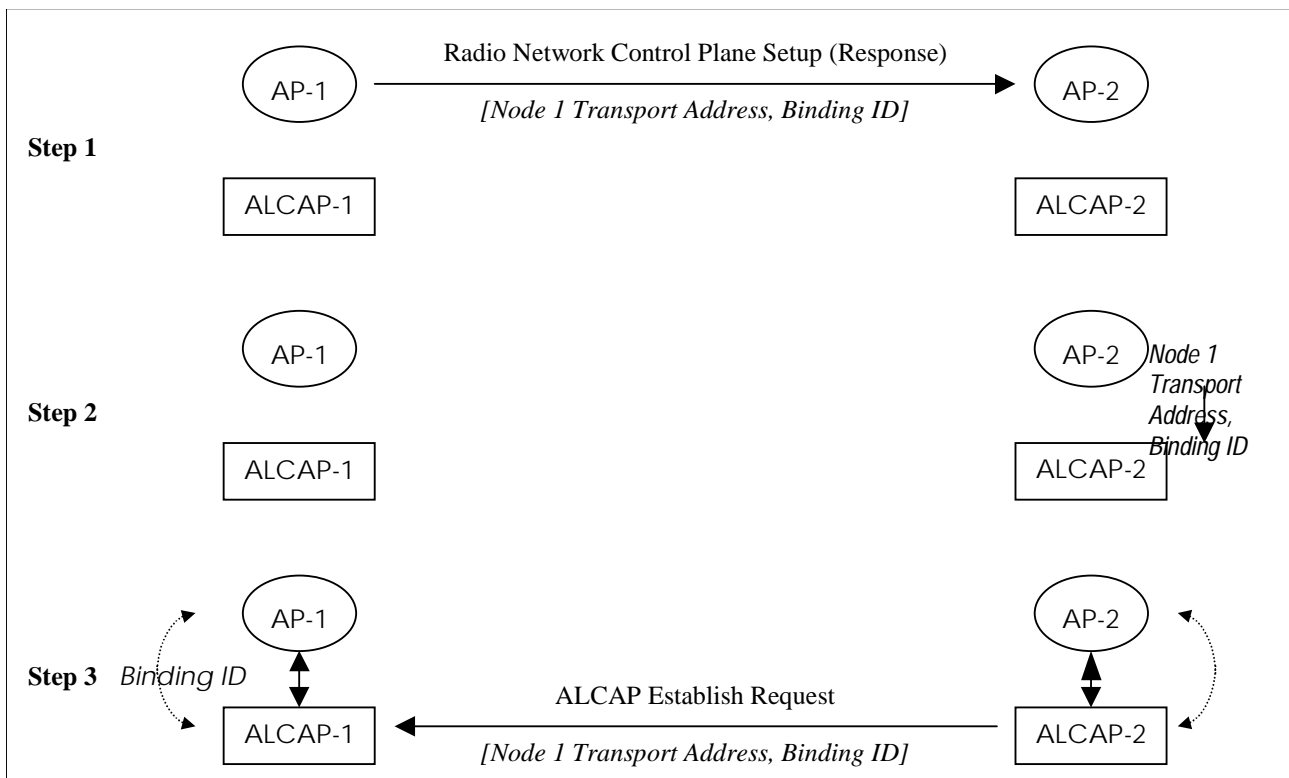

- Step 1: Application Part AP-1 assigns the Binding Identifier and sends a Radio Network Control Plane Set-up (Response) message (which of the two messages depends on the involved interface - lu/lur or lub). The message contains the originating node Transport layer address and the Binding Identifier.
- Step 2: Among reception of the Radio Network Control Plane Set-up message, the peer entity AP-2 requests ALCAP-2 to establish a transport bearer. The Binding Identifier is passed to ALCAP-2.
- Step 3: ALCAP-2 sends an ALCAP Establish Request to the peer entity ALCAP-1. The message contains the Binding Identifier. The Binding Identifier allows correlating the incoming transport connection with the Application Part transaction in step 1.

**Figure 6a: Usage of Binding ID**

Table 3 indicates the binding identifier allocating entity in each interface.

**Table 3: Binding identifier allocating entity in each interface**

Reference point	Allocating entity	Application part message including Binding-ID
Iu	CN	Request from CN
Iur	DRNC	Response to the request from SRNC
Iub	Node-B	Response to the request from DRNC

## 6.1.9 URA Identity

The URA identity is used to uniquely identify an URA, which is a specified set of UTRAN and/or GERAN cells. The URA identity can be used to indicate to the UE and the SRNC which URA it shall use in case there are multiple URA identities broadcast in the cell where the UE is located.

## 6.1.10 Service Identifiers for MBMS

### 6.1.10.1 IP Multicast Address and APN

The IP Multicast Address and an APN are used to enable the routing of MBMS registration requests within the CN. These identifiers are transparent to RAN.

### 6.1.10.2 TMGI

The Temporary Mobile Group Identity (TMGI) is used for group notification purposes and is unique within HPLMN. TMGI is used at the start of a session and at UE linking to identify an MBMS Bearer Service.

The structure of TMGI is specified in TS 23.003 [6].

### 6.1.10.3 Session Identifier

MBMS session Identifier is used to identify one specific session of a MBMS service and is forwarded transparently to the UE.

### 6.1.10.4 MBMS Service Area

The MBMS Service Area is defined in TS 25.413 [31].

The mapping between a MBMS Service Area and a list of cells is set in the RNC via O&M.

### 6.1.10.5 MBMS Cell Group Identifier

The MBMS Cell Group Identifier is defined in TS 25.346 [30]

### 6.1.10.6 MBMS UTRAN Cell Group Identifier

Void.

## 6.1.11 Transport Network Identifiers for MBMS

Transport Network identifiers are used in the Transport Network Layer (TNL) to identify the MBMS transport bearers and may be used in User Plane in the actual MBMS data transmission using the transport link. Each MBMS Transport Network identifier can be binded to an Application Part identifier. The Application Part identifier over the Iu interface is the TMGI corresponding to one MBMS Bearer Service.

The handling of the MBMS Transport Network identifiers is the same as the handling of Transport Network identifiers for dedicated resources described in section 6.1.8.2.

## 6.1.12 Binding Identifiers for MBMS

Binding identifiers can be used for MBMS both in Radio Network Control plane Application Part protocols and in Transport Network Control Plane's ALCAP protocol. When ALCAP is used, Binding Identifiers (Binding ID) are used to initialise the linkage between ALCAP and the MBMS Application Part (RNSAP, NBAP) identifiers. When no ALCAP is used, the Binding ID may also be used to carry the UDP port on Iub and Iur interfaces.

The handling of the MBMS Binding identifiers is the same as the handling of Binding identifiers for dedicated resources described in section 6.1.8.3.

## 6.1.13 Use of Extended Identifiers

The use and deployment of extended RNC-ID and extended S-RNTI in deployments is described in Annex A2.

## 6.2 Transport Addresses

The transport layer address parameter is transported in the radio network application signalling procedures that result in establishment of transport bearer connections.

The transport layer address parameter shall not be interpreted in the radio network application protocols and reveal the addressing format used in the transport layer.

The formats of the transport layer addresses are further elaborated in TS 25.414 [9], TS 25.424 [10], TS 25.434 [11], TS 25.426 [18].

## 6.3 Function Distribution Principles

For radio resource management functionality, the following principles apply:

- The CRNC owns the radio resources of a cell.
- The SRNC handles the connection to one UE, and may borrow radio resources of a certain cell from the CRNC.
- When used, the MRNC controls the logical resources of the RNSs that are used for MBSFN operation within the MBSFN cluster(s).

Dynamical control of power for dedicated channels, within limits admitted by CRNC, is done by the SRNC.

- Dynamic control on smaller time-scale for some radio links of the UE connection may be done by the Node B. This "inner loop" control is controlled by an "outer loop", for which the SRNC has overall responsibility.
- Scheduling of data for dedicated channels is done by the SRNC, while for common channels it is done by the CRNC.

For management of node-internal resources, the following principle apply:

- Each UTRAN node is considered a network element on its own. The knowledge about the equipment of a network element is kept within the network element itself and its management system. The node itself always manages node-internal resources.

For transport network resource management, the following principle apply:

- Management of transport network resources belong to the Transport Layer. Mechanisms relevant for the selected transport technology are used. No functional split between UTRAN nodes is specified what regards the Transport Layer.

As a general guideline, the UTRAN protocols should be designed in such a way that they minimise the need for a DRNC to interpret the user plane frame protocol information other than for the combining/splitting purpose.

---

## 7 UTRAN Functions description

### 7.1 List of functions

- Transfer of User Data.
- Functions related to overall system access control:
  - Admission Control;
  - Congestion Control;
  - System information broadcasting.
- Radio channel ciphering and deciphering.
- Integrity protection.
- Functions related to mobility:
  - Handover;
  - SRNS Relocation;
  - Paging support;
  - Positioning;
  - GERAN System Information Retrieval;
  - Enhanced SRNS Relocation.
- Functions related to radio resource management and control:
  - Radio resource configuration and operation;
  - Radio environment survey;
  - Combining/splitting control;
  - Connection set-up and release;
  - Allocation and deallocation of Radio Bearers;
  - [TDD - Dynamic Channel Allocation (DCA)];
  - Radio protocols function;
  - RF power control;
  - [3.84 Mcps TDD and 7.68Mcps TDD - Timing Advance];
  - [1.28 Mcps TDD – Uplink Synchronisation];
  - Radio channel coding;
  - Radio channel decoding;
  - Channel coding control;
  - Initial (random) access detection and handling;
  - CN Distribution function for Non Access Stratum messages.
- Synchronisation.

- Functions related to broadcast and multicast services (see note) (broadcast/multicast interworking function BM-IWF).

NOTE: Only Broadcast is applicable for Release 99.

- Broadcast/Multicast Information Distribution.
- Broadcast/Multicast Flow Control.
- CBS Status Reporting.
- Tracing.
- MDT.
- Volume reporting.
- NAS Node Selection.
- RAN Information Management.
- MBMS provision.
- MBMS Notification.
- MOCN and GWCN configuration support.
- SIPTO at Iu-PS (optional).
- Explicit Congestion Notification.

## 7.2 Functions description

### 7.2.0 Transfer of user data

This function provides user data transfer capability across the UTRAN between the Iu and Uu reference points.

### 7.2.1 Functions related to overall system access control

System access is the means by which a UMTS user is connected to the UTRAN in order to use UMTS services and/or facilities. User system access may be initiated from either the mobile side, e.g. a mobile originated call, or the network side, e.g. a mobile terminated call.

#### 7.2.1.1 Admission Control

The purpose of the admission control is to admit or deny new users, new radio access bearers or new radio links (for example due to handover). The admission control should try to avoid overload situations and base its decisions on interference and resource measurements. The admission control is employed at for example initial UE access, RAB assignment/reconfiguration and at handover. These cases may give different answers depending on priority and situation.

The Admission Control function based on UL interference and DL power is located in the Controlling RNC.

The Serving RNC is performing admission Control towards the Iu interface.

#### 7.2.1.2 Congestion Control

The task of congestion control is to monitor, detect and handle situations when the system is reaching a near overload or an overload situation with the already connected users. This means that some part of the network has run out, or will soon run out of resources. The congestion control should then bring the system back to a stable state as seamless as possible.

NOTE: This admission Control function is related to Radio Resources.

Congestion control is performed within UTRAN.

The RNC may trigger EAB as specified in TS 23.060 [36] subclause 5.3.6.4 and TS 23.251[28] subclause 4.6.

### 7.2.1.3 System information broadcasting

This function provides the mobile station with the Access Stratum and Non Access Stratum information which are needed by the UE for its operation within the network.

The basic control and synchronisation of this function is located in UTRAN.

### 7.2.1.4 MOCN and GWCN configuration support

In the MOCN configuration only the radio access part of the network is shared. For the MOCN configuration it is required that the rerouting function, as described in TS 25.410 [29], is supported.

In the GWCN configuration, besides shared radio access network, the core network operators also share part of the core network, at least MSC and/or SGSN.

For both the GWCN and MOCN configurations, the RNC carries the selected PLMN-id between network sharing supporting UEs and the corresponding CN.

The network sharing MOCN and GWCN configurations are described in detail in TS 23.251 [28].

## 7.2.2 Radio channel ciphering and deciphering

This function is a pure computation function whereby the radio transmitted data can be protected against a non-authorized third-party. Ciphering and deciphering may be based on the usage of a session-dependent key, derived through signalling and/or session dependent information.

This function is located in the UE and in the UTRAN.

## 7.2.3 Functions related to Mobility

### 7.2.3.1 Handover

This function manages the mobility of the radio interface. It is based on radio measurements and it is used to maintain the Quality of Service requested by the Core Network.

Handover may be directed to/from another system (e.g. UMTS to GSM handover).

The handover function may be either controlled by the network, or independently by the UE. Therefore, this function may be located in the SRNC, the UE, or both.

### 7.2.3.2 SRNS Relocation

The SRNS Relocation function coordinates the activities when the SRNS role is to be taken over by another RNS/BSS. The SRNS relocation function manages the Iu interface connection mobility from an RNS to another RNS/BSS.

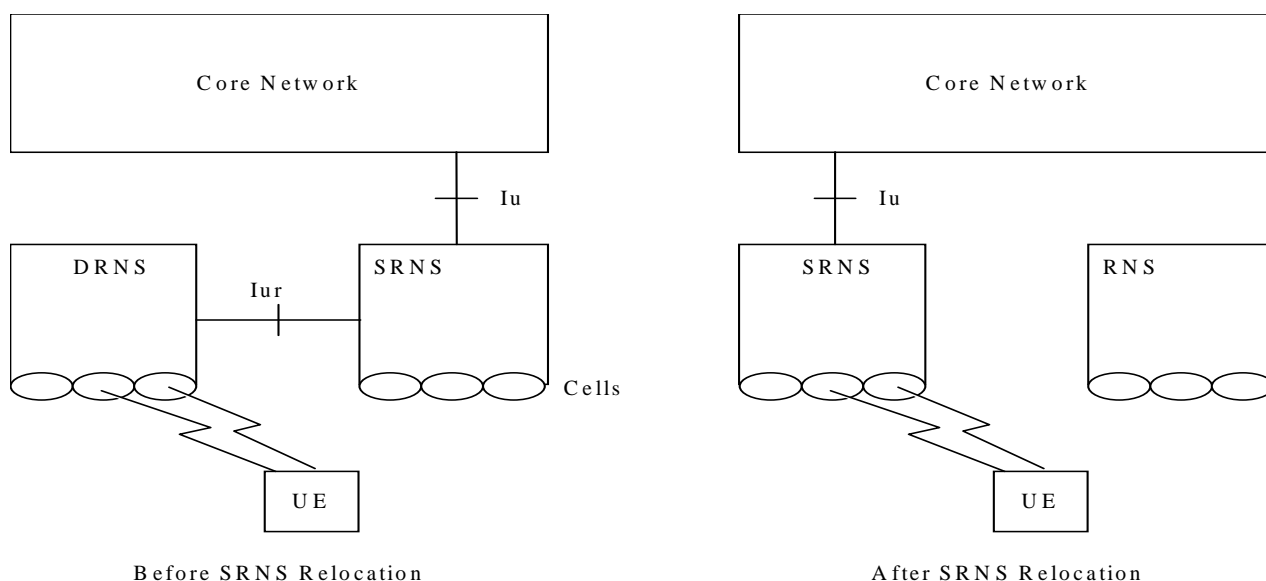

**Figure 7: Serving RNS Relocation**

The SRNS Relocation is initiated by the SRNC.

This function is located in the RNC and the CN.

### 7.2.3.3 Paging support

This function provides the capability to request a UE to contact the UTRAN/GERAN Iu mode when the UE is in Idle, CELL\_PCH or URA\_PCH/GRA\_PCH states (TS 25.331 [7], TR 43.930 [21]). This function also encompasses a coordination function between the different Core Network Domains onto a single RRC connection.

### 7.2.3.4 Positioning

This function provides the capability to determine the geographic position and optionally the velocity of a UE.

### 7.2.3.5 NAS Node Selection Function

The optional NAS Node Selection Function (NNSF) enables the RNC to initially assign CN resources to serve a UE and subsequently setup a signalling connection to the assigned CN resource.

The NNSF is described in detail in TS 23.236 [20].

### 7.2.3.6 Shared Networks Access Control

The Shared Networks Access Control function allows the CN to request the UTRAN to apply UE specific access control to LAs of the UTRAN and LAs of neighbouring networks.

The Shared Networks Access Control function is based on either whole PLMNs or Shared Network Areas (SNAs). An SNA is an area corresponding to one or more LAs within a single PLMN to which UE access can be controlled.

In order to apply Shared Networks Access Control for the UTRAN or for a neighbouring system, the UTRAN shall be aware of whether the concerned LA belongs to one (or several) SNA(s) or not.

If access for a specific UE needs to be restricted, the CN shall provide SNA Access Information for that UE. The SNA Access Information indicates which PLMNs and/or which SNAs the UE is allowed to access.

Based on whether the LA belongs to the PLMNs or SNAs the UE is allowed to access, the UTRAN determines if access to a certain LA for a certain UE shall be allowed.

If access is not allowed, the UTRAN shall request the CN to release existing resources either by initiating Iu Release Request procedure with cause value "Access Restricted due to Shared Network" or by requesting a relocation with the same cause value.

### 7.2.3.7 GERAN System Information Retrieval

In order to provide the UE with system information related to NACC towards a GERAN system - to be used as an optimisation - the GERAN System Information Retrieval function allows:

- The source RAN to request GERAN (via CN) to provide this system information.
- The SRNC to request the DRNC (via Iur interface) to provide this system information, if available.

The request and subsequent transfer of the GERAN System Information is performed transparently with the RIM function. The RIM function is further described in section 7.2.8.

### 7.2.3.8 Enhanced SRNS Relocation

The Enhanced SRNS Relocation function coordinates the activities when the SRNS role is to be taken over by another RNS. The Enhanced SRNS Relocation function manages the Iu interface connection mobility from an RNS to another RNS.

The Enhanced SRNS Relocation is initiated by the SRNC. The relocation of the SRNS functionality is prepared via RNSAP means. The CN is not informed until the preparation and execution of the relocation has taken place.

This function is located in the RNC and the CN.

### 7.2.3.9 Subscriber Profile ID for RAT/Frequency Priority

The RRM strategy in UTRAN may be based on user specific information.

The Subscriber Profile ID for RAT/Frequency Priority (SPID) parameter received by the RNC via the Iu interface is an index referring to user information (e.g. mobility profile, service usage profile). The information is UE specific and applies to all its Radio Bearers.

This index is mapped by the RNC to locally defined configuration in order to apply specific RRM strategies (e.g. to define RRC\_IDLE mode priorities and control inter-RAT/inter frequency handover in RRC\_CONNECTED mode).

## 7.2.4 Functions related to radio resource management and control

*Radio resource management* is concerned with the allocation and maintenance of radio communication resources. UMTS radio resources must be shared between circuit transfer mode services and packet transfer modes services (i.e. Connection-oriented and/or connectionless-oriented services).

### 7.2.4.1 Radio resource configuration and operation

This function performs configures the radio network resources, i.e. cells and common transport channels, and takes the resources into or out of operation.

### 7.2.4.2 Radio environment survey

This function performs measurements on radio channels (current and surrounding cells) and translates these measurements into radio channel quality estimates. Measurements may include:

- 1) Received signal strengths (current and surrounding cells);
- 2) Estimated bit error ratios, (current and surrounding cells);
- 3) Estimation of propagation environments (e.g. high-speed, low-speed, satellite, etc.);
- 4) Transmission range (e.g. through timing information);



- 5) Doppler shift;
- 6) Synchronisation status;
- 7) Received interference level;
- 8) Total DL transmission power per cell.

This function is located in the UE and in the UTRAN.

#### 7.2.4.3 Combining/splitting control

This function controls the combining/splitting of information streams to receive/ transmit the same information through multiple physical channels (possibly in different cells) from/ towards a single mobile terminal.

The UL combining of information streams may be performed using any suitable algorithm, for example:

- [FDD - based on maximum ratio algorithm (maximum ratio combining)];
- [FDD - based on quality information associated to each TBS (selection-combining)];
- [TDD - based on the presence/absence of the signal (selection)].

[FDD - combining/splitting control should interact with channel coding control in order to reduce the bit error ratio when combining the different information streams].

In some cases, depending on physical network configuration, there may be several entities which combine the different information streams, i.e. there may be combining/splitting at the SRNC, DRNC or Node B level.

This function is located in the UTRAN.

#### 7.2.4.4 Connection set-up and release

This function is responsible for the control of connection element set-up and release in the radio access sub network. The purpose of this function is:

- 1) To participate in the processing of the end-to-end connection set-up and release;
- 2) And to manage and maintain the element of the end-to-end connection, which is located in the radio access sub network.

In the former case, this function will be activated by request from other functional entities at call set-up/release. In the latter case, i.e. when the end-to-end connection has already been established, this function may also be invoked to cater for in-call service modification or at handover execution.

This function is located both in the UE and in the RNC.

#### 7.2.4.5 Allocation and deallocation of Radio Bearers

This function consists of translating the connection element set-up (resp. release) requests into physical radio channel allocation (resp. deallocation) accordingly to the QoS of the Radio Access Bearer.

This function may be activated during the call since e.g. the user service request may vary, or macro diversity may be used.

This function is located in the CRNC and SRNC.

#### 7.2.4.6 [TDD - Dynamic Channel Allocation (DCA)]

DCA is used in the TDD mode. It includes Fast DCA and Slow DCA. Slow DCA is the process of assigning radio resources, including time slots, to different TDD cells according to the varying cell load. Fast DCA is the process of assigning resources to Radio Bearers, and is related to Admission Control.

### 7.2.4.7 Radio protocols function

This function provides user data and signalling transfer capability across the UMTS radio interface by adapting the services (according to the QoS of the Radio Access Bearer) to the Radio transmission. This function includes amongst other:

- Multiplexing of services and multiplexing of UEs on Radio bearers;
- Segmentation and reassembly;
- Acknowledged/Unacknowledged delivery according to the Radio Access Bearer QoS.

### 7.2.4.8 RF power control

This group of functions controls the level of the transmitted power in order to minimise interference and keep the quality of the connections. It consist of the following functions: UL Outer Loop Power Control, DL Outer Loop Power Control, UL Inner Loop Power Control, DL Inner Loop Power Control, UL Open Loop Power Control and DL Open Loop Power Control.

#### 7.2.4.8.1 UL Outer Loop Power Control

The UL Outer Loop Power Control located in the SRNC [TDD – except for uplink shared channels where it is located in the CRNC] sets the target quality value for the UL Inner Loop Power Control which is located in Node B for FDD and 1.28 Mcps TDD and is located in the UE for 3.84 Mcps and 7.68Mcps TDD. It receives input from quality estimates of the transport channel. The UL outer loop power control is mainly used for a long-term quality control of the radio channel.

In FDD and 1.28 Mcps TDD this function is located in the UTRAN, in 3.84 Mcps and 7.68 Mcps TDD the function is performed in UTRAN and the target quality value is sent to the UE by the SRNC or the CRNC, respectively.

In FDD and 1.28 Mcps TDD, if the connection involves both a SRNS and a DRNS the function UL Outer Loop Power Control (located in the SRNC [1.28 Mcps TDD – or in the CRNC, respectively]) sets the target quality for the UL Inner Loop Power Control function (located in Node B).

#### 7.2.4.8.2 DL Outer Loop Power Control

The DL Outer Loop Power Control sets the target quality value for the DL inner loop power control. It receives input from quality estimates of the transport channel, measured in the UE. The DL outer loop power control is mainly used for a long-term quality control of the radio channel.

This function is located mainly in the UE, but some control parameters are set by the UTRAN.

The SRNC, regularly (or under some algorithms), sends the target down link power range based on the measurement report from UE.

#### 7.2.4.8.3 UL Inner Loop Power Control

The UL Inner Loop Power Control sets the power of the uplink dedicated [TDD – and shared] physical channels.

In FDD, it is a closed loop process. It receives the quality target from UL Outer Loop Power Control and quality estimates of the uplink dedicated physical control channel. The power control commands are sent on the downlink dedicated physical control channel to the UE. This function is located in both the UTRAN and the UE.

In 3.84 Mcps and 7.68 Mcps TDD it is a open loop process, it receives the quality target from the UL Outer Loop Power Control and uses the quality target and quality estimates of downlink channels to set the transmit power. This function is located in the UE.

In 1.28 Mcps TDD, it is a closed loop process. It receives the quality target from UL Outer Loop Power Control, and quality estimates of the uplink dedicated physical channels as well as physical uplink shared channels, if any. The power control commands are sent on the downlink dedicated physical channels and physical downlink shared channels, if any, to the UE. This function is located in both the UTRAN and the UE.

#### 7.2.4.8.4 DL Inner Loop Power Control

The DL Inner Loop Power Control sets the power of the downlink dedicated [TDD – and shared] physical channels. It receives the quality target from DL Outer Loop Power Control and quality estimates of the [FDD - downlink dedicated physical control channel] [TDD – downlink dedicated physical channels and physical downlink shared channels if any]. The power control commands are sent on the [FDD - uplink dedicated physical control channel] [TDD – downlink dedicated physical channels and physical downlink shared channels if any] to the UTRAN.

This function is located in both the UTRAN and the UE.

#### 7.2.4.8.5 UL Open Loop Power Control

The UL Open Loop Power Control sets the initial power of the UE, i.e. at random access. The function uses UE measurements and broadcasted cell/system parameters as input.

This function is located in both the UTRAN and the UE.

#### 7.2.4.8.6 DL Open Loop Power Control

The DL Open Loop Power Control sets the initial power of downlink channels. It receives downlink measurement reports from the UE.

This function is located in both the UTRAN and the UE.

#### 7.2.4.9 Radio channel coding

This function introduces redundancy into the source data flow, increasing its rate by adding information calculated from the source data, in order to allow the detection or correction of signal errors introduced by the transmission medium. The channel coding algorithm(s) used and the amount of redundancy introduced may be different for the different types of logical channels and different types of data.

This function is located in both the UE and in the UTRAN.

#### 7.2.4.10 Radio channel decoding

This function tries to reconstruct the source information using the redundancy added by the channel coding function to detect or correct possible errors in the received data flow. The channel decoding function may also employ a priori error likelihood information generated by the demodulation function to increase the efficiency of the decoding operation. The channel decoding function is the complement function to the channel coding function.

This function is located in both the UE and in the UTRAN.

#### 7.2.4.11 Channel coding control

This function generates control information required by the channel coding/ decoding execution functions. This may include channel coding scheme, code rate, etc.

This function is located in both the UE and in the UTRAN.

#### 7.2.4.12 Initial (random) access detection and handling

This function will have the ability to detect an initial access attempt from a mobile station and will respond appropriately. The handling of the initial access may include procedures for a possible resolution of colliding attempts, etc. The successful result will be the request for allocation of appropriate resources for the requesting mobile station.

This function is located in the UTRAN.

#### 7.2.4.13 CN Distribution function for Non Access Stratum messages

In the RRC protocol, messages from the NAS shall be transparently transferred within the Access Stratum using the Direct Transfer procedure. A distribution function in the UE and the SRNC shall handle the CN domain indicator being part of the AS message to direct messages to the appropriate NAS entity i.e. the appropriate Mobility Management instance in the UE domain and the appropriate CN domain.

In the downlink direction the UE shall be provided by the SRNC with the information on the originating CN domain for the individual NAS message.

In the uplink direction, the process performed by the distribution function in the UE consists in inserting the appropriate values for the CN domain indicator in the AS message and the process performed by the SRNC consists in evaluating the CN domain indicator contained in the AS message and distribute the NAS message to the corresponding RANAP instance for transfer over Iu interface.

This distribution function is located in both the UE and in the SRNC.

#### 7.2.4.14 [3.84 Mcps and 7.68 Mcps TDD - Timing Advance]

This function is used in uplink to align the uplink radio signals from the UE to the UTRAN. Timing Advance is based on uplink burst timing measurements performed by the Node B L1, and on Timing Advance commands sent downlink to the UE.

#### 7.2.4.15 Service specific function for Non Access Stratum messages

A service specific function in the UE provides a SAP for a particular service (e.g. a given priority). In the downlink direction, the SRNC may base the routing on this SAP.

This service specific function is located in both the UE and the SRNC.

#### 7.2.4.16 [1.28 Mcps TDD – Uplink Synchronisation]

This function is used in uplink to synchronise the uplink radio signals from the UE to the UTRAN. At the detection of uplink burst, the Node B will evaluate the received power level and timing, and reply by sending the adjustment information to UE to modify its timing and power level for next transmission and for establishment of the Uplink synchronisation procedure.

### 7.2.5 Functions related to broadcast and multicast services (broadcast/multicast interworking function BM-IWF)

See note.

#### 7.2.5.1 Broadcast/Multicast Information Distribution

The broadcast/multicast information distribution function distributes received CBS messages towards the BMC entities configured per cell for further processing. The distribution of broadcast/multicast information relate on the mapping between service area and cells controlled by the RNC. The provision of this mapping information is an O&M function.

NOTE: Only Broadcast is applicable for Release 99.

#### 7.2.5.2 Broadcast/Multicast Flow Control

When processing units of the RNC becomes congested, the Broadcast/Multicast Flow Control function informs the data source about this congestion situation and takes means to resolve the congestion.

#### 7.2.5.3 CBS Status Reporting

The RNC collects status data per cell (e.g. No-of-Broadcast-Completed-List, Radio-Resource-Loading-List), and matches these data to Service Areas. The status data is transmitted to the CBC, if a query has been made by the CBC.

## 7.2.6 Tracing

This function allows tracing of various events related to the UE and its activities.

## 7.2.7 Volume Reporting

The data volume reporting function is used to report the volume of unacknowledged data to the CN for accounting purpose.

## 7.2.8 RAN Information Management

The RAN Information Management (RIM) function is a generic mechanism that allows the request and transfer of information between two RAN nodes e.g. GERAN System information. The RIM mechanism allows to start, stop and resume both on demand and on event transfer of information. RIM also provides native error handling function at RIM level and at RIM application level. The RIM function is further described in TR 44.901 [22] and TS 48.018 [23].

## 7.2.9 Functions related to MBMS

### 7.2.9.1 MBMS provision

The MBMS provision enables the RNC to provide a multicast service via an optimised transmission of the MBMS bearer service in UTRAN via techniques such as PTM transmission, selective combining, Soft Combining and transmission mode selection between PTM and PTP bearer.

The MBMS provision enables the RNC to provide a broadcast service via a PTM transmission bearer.

### 7.2.9.2 MBMS Notification Coordination

The characteristic of MBMS implies a need for MBMS notification co-ordination i.e. specific handling of MBMS Notification when UE is in Cell-DCH state. MBMS notification co-ordination is performed by UTRAN when the session is ongoing. The TMGI is used for coordination.

The MBMS functions are further described in TS 25.346 [30].

## 7.2.10 SIPTO at Iu-PS

If supported, SIPTO at Iu-PS Function provides the capability to offload certain PS RABs from the CN at RAB setup. The SIPTO at Iu-PS is implementation dependent and may be implemented in a separate entity outside of RNS, for further information see TS 23.060 [36].

## 7.2.11 Explicit Congestion Notification

The RNC and the UE support of the Explicit Congestion Notification (ECN) is specified in Section 5 of IETF RFC 3168 [37] (i.e., the normative part of IETF RFC 3168 [37] that applies to the end-to-end flow of IP packets), and below. This enables the RNC to control the initial codec rate selection and/or to trigger a codec rate reduction. Thereby the RNC can increase capacity (e.g., in terms of number of accepted VoIP calls), and improve coverage (e.g. for high bit rate video sessions).

The RNC should set the Congestion Experienced (CE) codepoint ('11') in PDCP SDUs in the downlink direction to indicate downlink (radio) congestion if those PDCP SDUs have one of the two ECN-Capable Transport (ECT) codepoints set.

The RNC should set the Congestion Experienced (CE) codepoint ('11') in PDCP SDUs in the uplink direction to indicate uplink (radio) congestion if those PDCP SDUs have one of the two ECN-Capable Transport (ECT) codepoints set.

## 7.2.12 MDT

This function allows to activate and handle MDT sessions by trace procedure as described in TS37.320 [38].

---

## 8 Mobility Management

### 8.1 Signalling connection

Based on TS 23.110 [2], the UE may either have or not have a signalling connection:

- 1) When a signalling connection exists that is established over the Dedicated Control Service Access Point (DC-SAP) from the Access Stratum.  
Therefore, the CN can reach the UE by the dedicated connection SAP on the CN side, and the UTRAN has a context with the UE and CN for this particular connection. This context is erased when the connection is released. The *dedicated connection* can be initiated from the UE only.

NOTE: A dedicated connection is currently defined as Signalling Connection in TS 23.110 [2]. Note that in the radio interface, dedicated or common channels can be used.

Depending on the activity of a UE, the location of the UE is known either on cell level (higher activity) or in a larger area consisting of several cells (lower activity). This will (i) minimise the number of location update messages for moving UEs with low activity and (ii) remove the need for paging for UEs known on cell level.

- 2) When a dedicated connection does not exist, the CN must reach the UE via the Notification SAP. The message sent to the UE can be a request to the UE to establish a dedicated connection. The UE is addressed with a user/terminal identity and a "geographical area".

### 8.2 Consequences for Mobility Handling

It is generally agreed to contain radio access specific procedures within UTRAN. This means that all cell level mobility should be handled within UTRAN. Also the cell structure of the radio network should not necessarily be known outside the UTRAN.

When there exists a dedicated connection to the UE, the UTRAN shall handle the radio interface mobility of the UE. This includes procedures such as soft handover, and procedures for handling mobility in the CELL\_PCH and URA\_PCH/GRA\_PCH state TS 25.331 [7].

When a dedicated connection between the UTRAN and the UE does not exist, no UE information is needed in UTRAN. Therefore, the mobility is handled directly between UE and CN outside access stratum (e.g. by means of registration procedures). When paging the UE, the CN indicates a 'geographical area' that is translated within UTRAN to the actual cells that shall be paged. A 'geographical area' shall be identified in a cell-structure independent way. One possibility is the use of 'Location Area identities'.

During the lifetime of the dedicated connection, the registrations to the CN are suppressed by the UE. When a dedicated connection is released, the UE performs a new registration to the CN, when needed.

Thus, the UTRAN does not contain any permanent 'location registers' for the UE, but only temporary contexts for the duration of the dedicated connection. This context may typically contain location information (e.g. current cell(s) of the UE) and information about allocated radio resources and related connection references.

---

## 9 Synchronisation

### 9.1 SYNCHRONISATION MODEL

Different synchronisation issues are identified within UTRAN, i.e.:

- Network Synchronisation;
- Node Synchronisation;
- Transport Channel synchronisation;

- Radio Interface Synchronisation;
- Time Alignment handling.

The Nodes involved by the above mentioned synchronisation issues (with exception of Network and Node Synchronisation) are shown by the Synchronisation Issues Model of figure 8. Further details of synchronisation are in TS 25.402 [5].

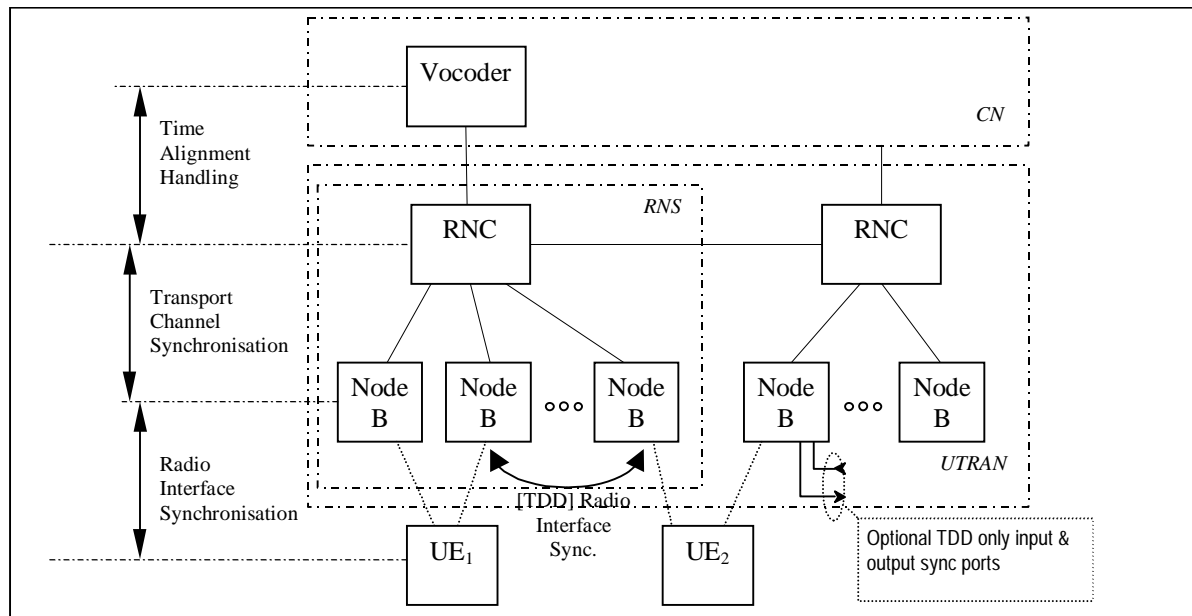
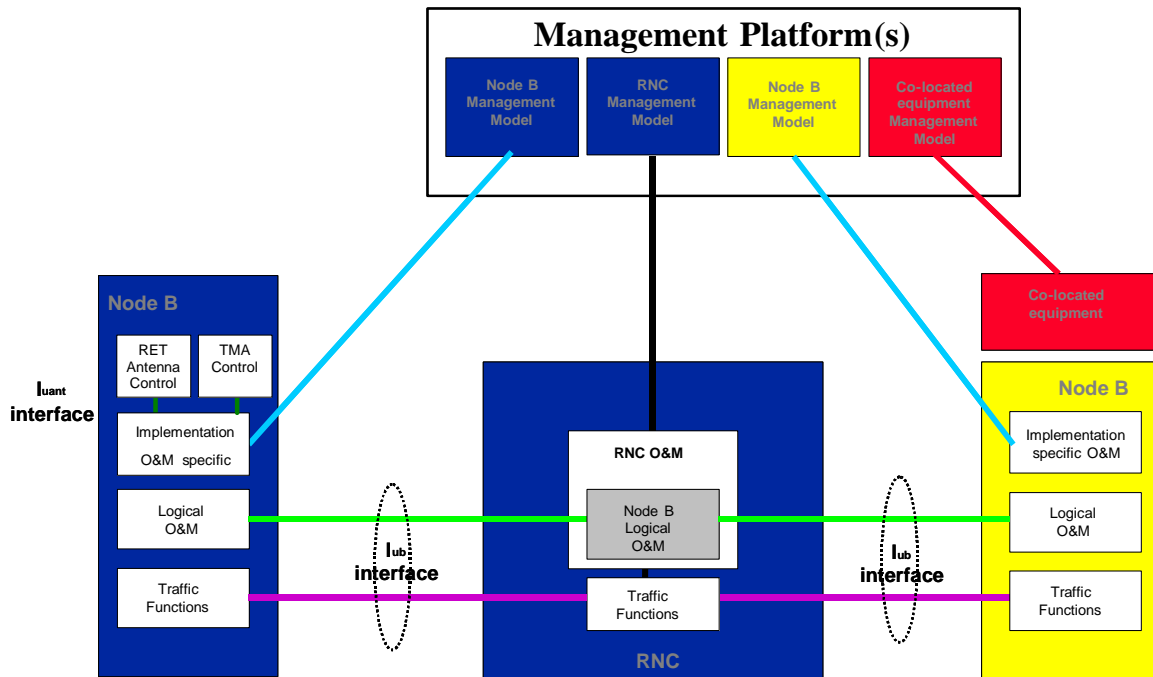

Figure 8: Synchronisation issues model

## 10 UTRAN O&M Requirements

### 10.1 O&M of Node B

The O&M of Node B is separated in two parts: the O&M linked to the actual implementation of Node B, denoted as Implementation Specific *O&M*, and the O&M which impacts on the traffic carrying resources in Node B controlled from the RNC, denoted *logical O&M*. The RNS architecture with the O&M interfaces is shown in figure 9.



**Figure 9: RNS architecture with O&M interfaces**

NOTE 1: The concept of an interface from the RNC to the management system is shown for clarity only. It's definition is outside the scope of 3GPP-TSG-RAN-WG3.

NOTE 2: The presentation of the O&M functions within the management system is shown for clarity only. Their actual implementation is outside the scope of 3GPP-TSG-RAN-WG3.

NOTE 3: The standardisation of the Implementation Specific O&M is outside the scope of 3GPP-TSG-RAN-WG3. The 3GPP-TSG-RAN-WG3 should only address the bearer for the Implementation Specific O&M.

NOTE 4: The figure shows only logical connections and does not intend to mandate any physical interfaces.

NOTE 5: The Iuant interface to the control unit of the RET antennas or TMAs is specified in the series of Technical Specifications 25.460 [24], 25.461 [25], 25.462 [26] and 25.466 [32]. An Implementation Specific O&M function is needed for the RET antennas or TMAs control to translate the control signalling from the Node B Element Manager into the control commands of the Iuant interface specified in TS 25.460 [24].

### 10.1.1 Implementation Specific O&M

The Implementation Specific O&M functions are heavily dependent on the implementation of Node B, both for its hardware components and for the management of the software components. It needs therefore to be implementation dependent, and be performed between Node B and the management system.

One solution for the transport of Implementation Specific O&M is to route from Node B to the management system via the RNC. In this case, the Implementation Specific O&M interface and Iub interface share the same physical bearer, and TS 25.442 [4] specifies the routing function and the transport bearer for this scenario. The deployment of the routing across the RNC in the UTRAN is optional. Where signalling between co-located equipment and its management system is required, this may be carried over the same bearer as Implementation Specific O&M.

### 10.1.2 Logical O&M

Logical O&M is the signalling associated with the control of logical resources (channels, cells,...) owned by the RNC but physically implemented in the Node B. The RNC controls these logical resources. A number of O&M procedures physically implemented in Node B impact on the logical resources and therefore require an information exchange between RNC and Node B. All messages needed to support this information exchange are classified as Logical O&M forming an integral part of NBAP.



# 11 UTRAN Interfaces

## 11.1 General Protocol Model for UTRAN Interfaces

### 11.1.1 General

The general protocol model for UTRAN Interfaces is depicted in figure 10, and described in detail in the following subclauses. The structure is based on the principle that the layers and planes are logically independent of each other. Therefore, as and when required, the standardisation body can easily alter protocol stacks and planes to fit future requirements.

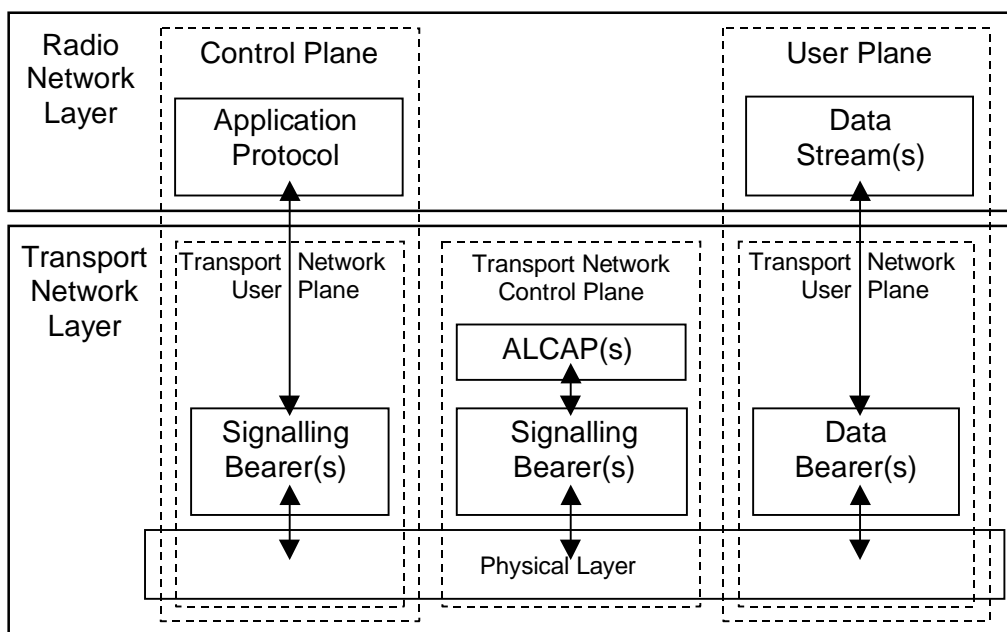

Figure 10: General Protocol Model for UTRAN Interfaces

### 11.1.2 Horizontal Layers

The Protocol Structure consists of two main layers, Radio Network Layer, and Transport Network Layer. All UTRAN related issues are visible only in the Radio Network Layer, and the Transport Network Layer represents standard transport technology that is selected to be used for UTRAN, but without any UTRAN specific requirements.

### 11.1.3 Vertical Planes

#### 11.1.3.1 Control Plane

The Control Plane Includes the Application Protocol, i.e. RANAP, RNSAP or NBAP, and the Signalling Bearer for transporting the Application Protocol messages.

Among other things, the Application Protocol is used for setting up bearers for (i.e. Radio Access Bearer or Radio Link) in the Radio Network Layer. In the three plane structure the bearer parameters in the Application Protocol are not directly tied to the User Plane technology, but are rather general bearer parameters.

The Signalling Bearer for the Application Protocol may or may not be of the same type as the Signalling Protocol for the ALCAP. The Signalling Bearer is always set up by O&M actions.

### 11.1.3.2 User Plane

The User Plane Includes the Data Stream(s) and the Data Bearer(s) for the Data Stream(s). The Data Stream(s) is/are characterised by one or more frame protocols specified for that interface.

### 11.1.3.3 Transport Network Control Plane

The Transport Network Control Plane does not include any Radio Network Layer information, and is completely in the Transport Layer. It includes the ALCAP protocol(s) that is/are needed to set up the transport bearers (Data Bearer) for the User Plane. It also includes the appropriate Signalling Bearer(s) needed for the ALCAP protocol(s).

The Transport Network Control Plane is a plane that acts between the Control Plane and the User Plane. The introduction of Transport Network Control Plane is performed in a way that the Application Protocol in the Radio Network Control Plane is kept completely independent of the technology selected for Data Bearer in the User Plane. Indeed, the decision to actually use an ALCAP protocol is completely kept within the Transport Network Layer.

It should be noted that ALCAP might not be used for all types Data Bearers. If there is no ALCAP signalling transaction, the Transport Network Control Plane is not needed at all. This is the case when pre-configured Data Bearers are used or when the IP (IETF RFC 791 [17]) UTRAN option is used between two IP UTRAN nodes or between an IP UTRAN node and an IP CN node.

When Transport Network Control Plane is used, the transport bearers for the Data Bearer in the User Plane are set up in the following fashion. First there is a signalling transaction by the Application Protocol in the Control Plane, which triggers the set up of the Data Bearer by the ALCAP protocol that is specific for the User Plane technology.

The following interworking alternatives are specified for the IP-ATM interworking:

- 1) ATM/IP Dual Stack supported in the IP UTRAN node. When an ATM/IP dual stack is implemented in the IP UTRAN node, support of an IP ALCAP protocol is not required.

Annex A of TS 25.414 [9] shows an example of protocols for the case the ATM&IP UTRAN/CN-node has no ATM connectivity.

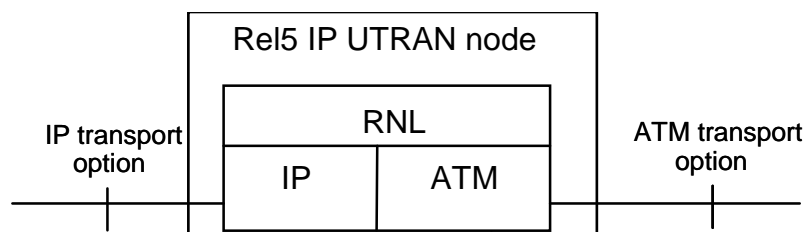

- 2) An Interworking Function (IWF), either internal or external to the UTRAN/CN node.

Annex A of TS 25.414 [9] shows an example of a protocol stack for the case when the IWF is an external unit to the UTRAN/CN node. Other protocol stacks for this case are not precluded.

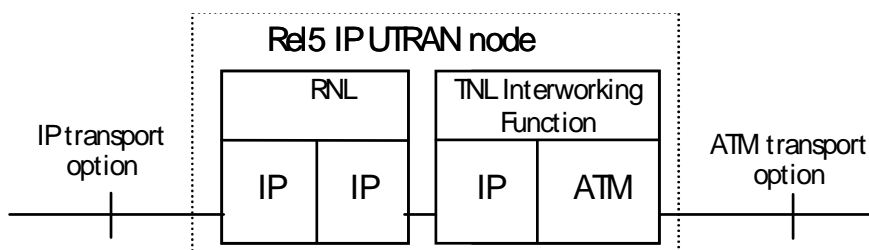

### 11.1.3.4 Transport Network User Plane

The Data Bearer(s) in the User Plane, and the Signalling Bearer(s) for Application Protocol, belong also to Transport Network User Plane. As described in the previous subclause, the Data Bearers in Transport Network User Plane are directly controlled by Transport Network Control Plane during real time operation, but the control actions required for setting up the Signalling Bearer(s) for Application Protocol are considered O&M actions.

## 11.2 Protocol Model (Informative)

The following subclause is an informative subclause which aims to provide an overall picture of how the MAC layer is distributed over Uu, Iub and Iur for the RACH, FACH, DCH, [TDD – DSCH, USCH] and HS-DSCH.

### 11.2.1 RACH Transport Channel

Figure 11 shows the protocol stack model for the RACH transport channel when the Controlling and Serving RNC are co-incident.

For the RACH transport channel, Dedicated MAC (MAC-d) uses the services of Common MAC (MAC-c/sh).

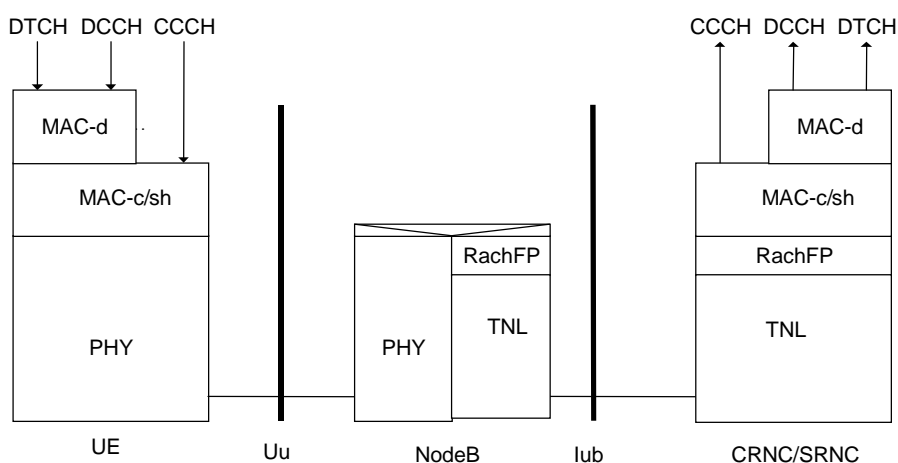

**Figure 11: RACH: Coincident Controlling and Serving RNC**

The Common MAC (MAC-c/sh) entity in the UE transfers MAC-c/sh PDU to the peer MAC-c/sh entity in the RNC using the services of the Physical Layer.

An Interworking Function (IWF) in the Node B interworks the RACH frame received by the PHY entity into the RACH Frame Protocol (RACH FP) entity.

The RACH Frame Protocol entity adds header information to form a RACH FP PDU that is transported to the RNC over a transport bearer.

At the RNC, the RACH FP entity delivers the MAC-c/sh PDU to the MAC-c/sh entity.

Figure 12 shows the protocol model for the RACH transport channel with separate Controlling and Serving RNC. In this case, Iur RACH Frame Protocol (RACH FP) is used to interwork the Common MAC (MAC-c/sh) at the Controlling RNC with the Dedicated MAC (MAC-d) at the Serving RNC.

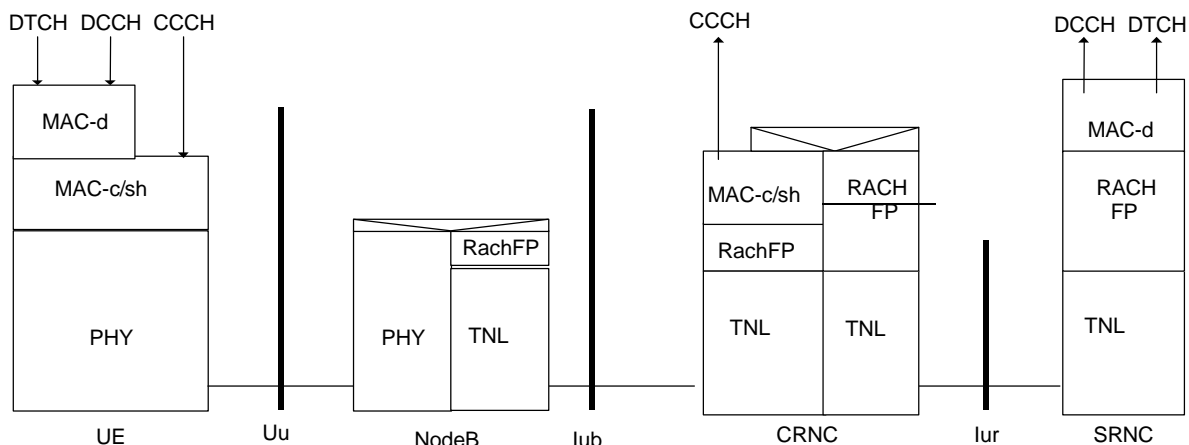

Figure 12: RACH: Separate Controlling and Serving RNC

### 11.2.2 CPCH [FDD] Transport Channel

Void.

### 11.2.3 FACH Transport Channel

Figure 15 shows the protocol model for the FACH transport channel when the Controlling and Serving RNC are co-incident.

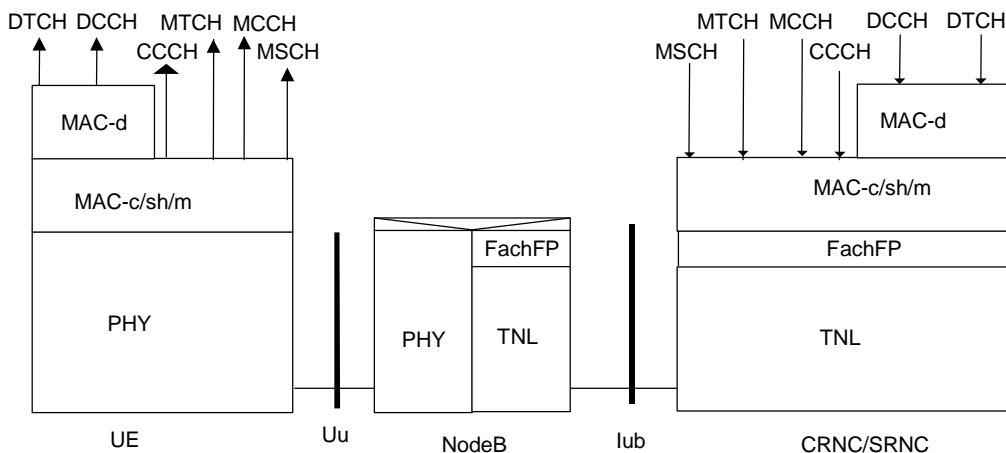

Figure 15: FACH Co-incident Controlling and Serving RNC

The Common MAC (MAC-c/sh/m) entity in the RNC transfers MAC-c PDU to the peer MAC-c entity in the UE using the services of the FACH Frame Protocol (FACH FP) entity.

The FACH Frame Protocol entity adds header information to form a FACH FP PDU which is transported to the Node B over a transport bearer.

An Interworking Function (IWF) in the Node B interworks the FACH frame received by FACH Frame Protocol (FACH FP) entity into the PHY entity.

FACH scheduling is performed by MAC-c/sh/m in the CRNC.

Figure 16 shows the protocol model for the FACH transport channel with separate Controlling and Serving RNC. In this case, Iur FACH Frame Protocol is used to interwork the Common MAC (MAC-c) at the Controlling RNC with the Dedicated MAC (MAC-d) at the Serving RNC.

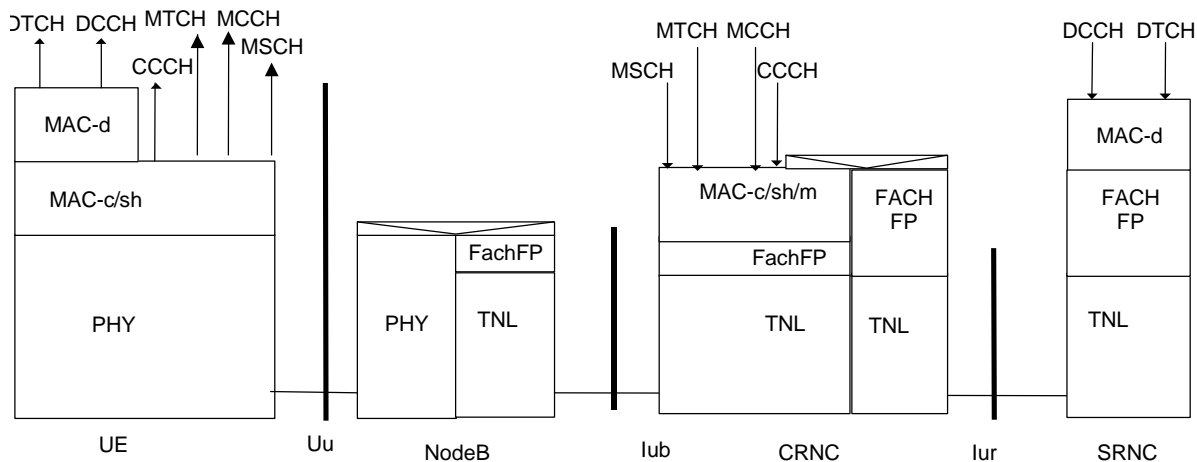

Figure 16: FACH: Separate Controlling and Serving RNC

### 11.2.4 DCH Transport Channel

Figure 17 shows the protocol model for the DCH transport channel when the Controlling and Serving RNC are co-incident.

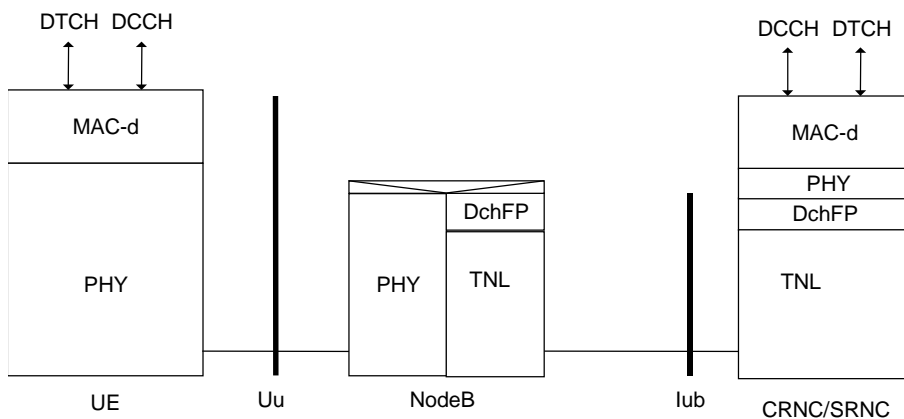
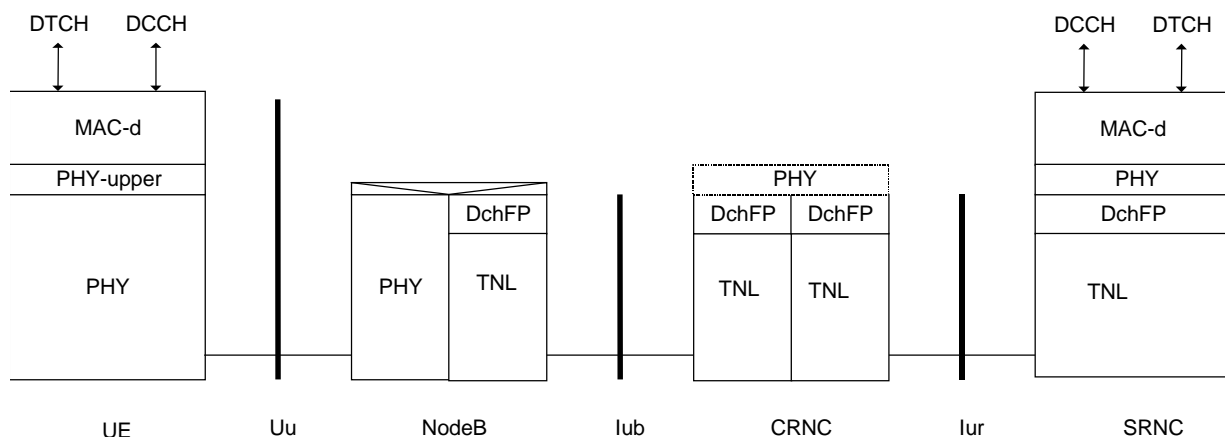

Figure 17: DCH: Co-incident Controlling and Serving RNC

The DCH transport channel introduces the concept of distributed PHY layer.

An Interworking Function (IWF) in the Node B interworks between the DCH Frame Protocol (DCH FP) entity and the PHY entity.

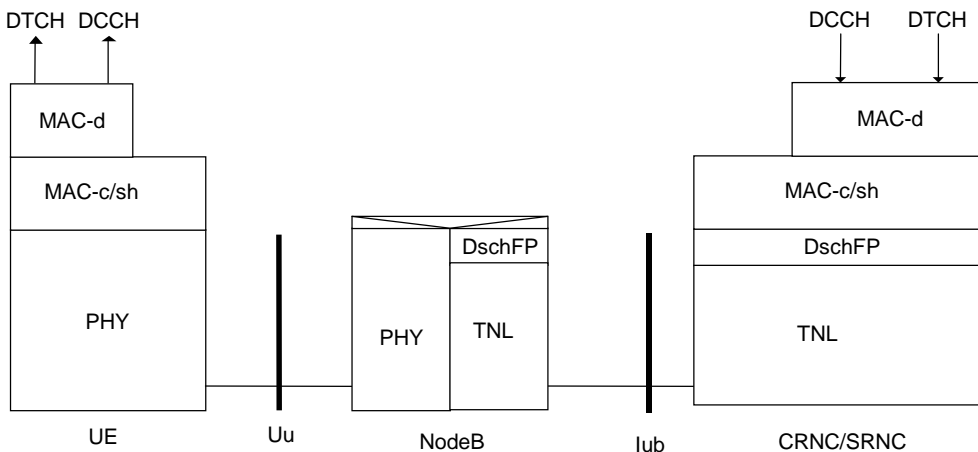

**Figure 18: DCH: Separate Controlling and Serving RNC**

Figure 18 shows the protocol model for the DCH transport channel with separate Controlling and Serving RNC. In this case, the Iub DCH FP is terminated in the CRNC and interworked with the Iur DCH FP through a PHY function. This function performs optional soft handover or can be a null function.

### 11.2.5 DSCH Transport Channel [TDD]

Figure 19 shows the protocol model for the DSCH transport channel when the Controlling and Serving RNC are co-incident.



**Figure 19: DSCH Co-incident Controlling and Serving RNC**

The Shared MAC (MAC-c/sh) entity in the RNC transfers MAC-c/sh PDU to the peer MAC-c/sh entity in the UE using the services of the DSCH Frame Protocol (DSCH FP) entity. The DSCH FP entity adds header information to form a DSCH FP PDU that is transported to the Node B over a transport bearer.

An Interworking Function (IWF) in the Node B interworks the DSCH frame received by DSCH FP entity into the PHY entity. DSCH scheduling is performed by MAC-c/sh in the CRNC.

Figure 20 shows the protocol model for the DSCH transport channel with separate Controlling and Serving RNC. In this case, Iur DSCH Frame Protocol is used to interwork the MAC-c/sh at the Controlling RNC with the MAC-d at the Serving RNC.

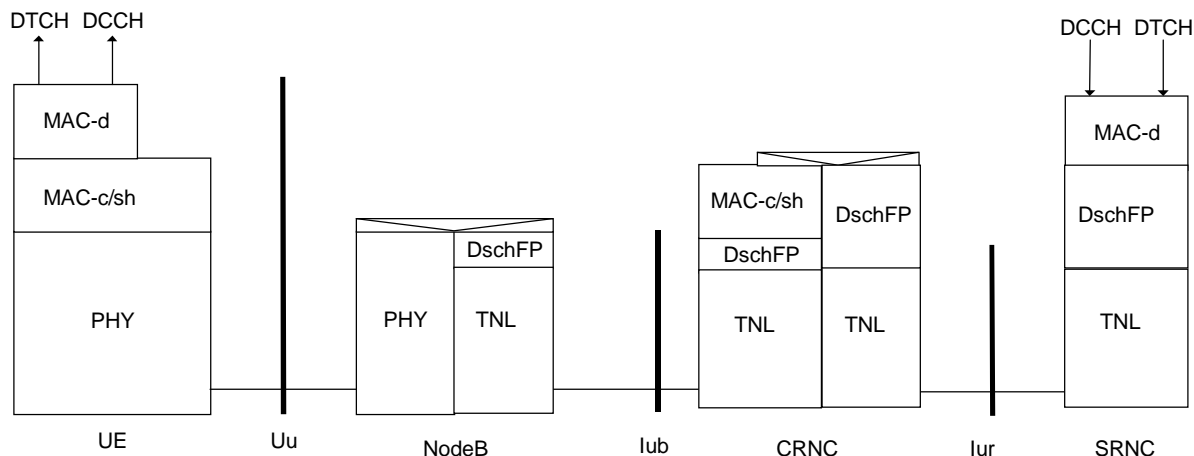

Figure 20: DSCH: Separate Controlling and Serving RNC

### 11.2.6 USCH Transport Channel [TDD]

Figure 21 shows the protocol model for the USCH transport channel when the Controlling and Serving RNC are coincident.

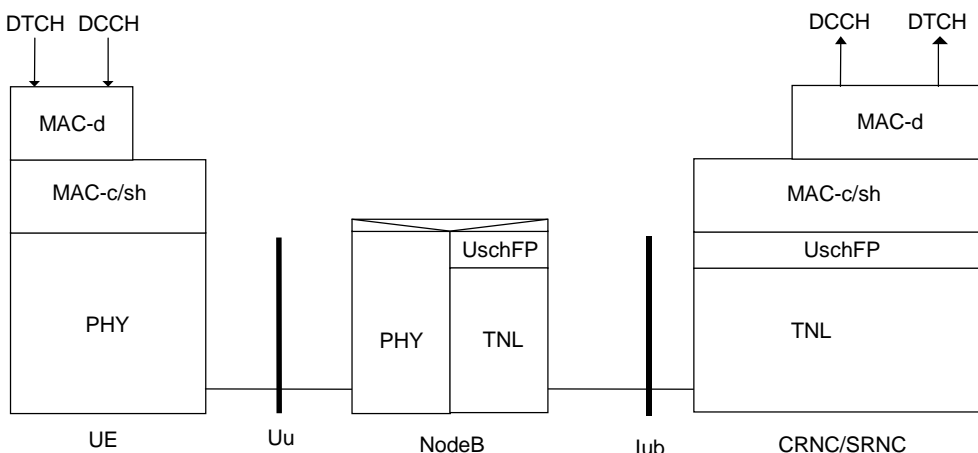

Figure 21: USCH Co-incident Controlling and Serving RNC

The Shared MAC (MAC-c/sh) entity in the RNC receives MAC-c/sh PDU from the peer MAC-c/sh entity in the UE using the services of the Interworking Function in the Node B, and the USCH Frame Protocol (USCH FP) entity. The USCH FP entity in the Node B adds header information to form a USCH FP PDU that is transported to the RNC over a transport bearer.

An Interworking Function (IWF) in the Node B interworks the received USCH PHY entity into an USCH frame to be transmitted by the USCH FP entity over the Iub interface. USCH scheduling is performed by MAC-c/sh in UE and by C-RRC in the CRNC.

Figure 22 shows the protocol model for the USCH transport channel with separate Controlling and Serving RNC. In this case, Iur USCH Frame Protocol is used to interwork the MAC-c/sh at the Controlling RNC with the MAC-d at the Serving RNC.

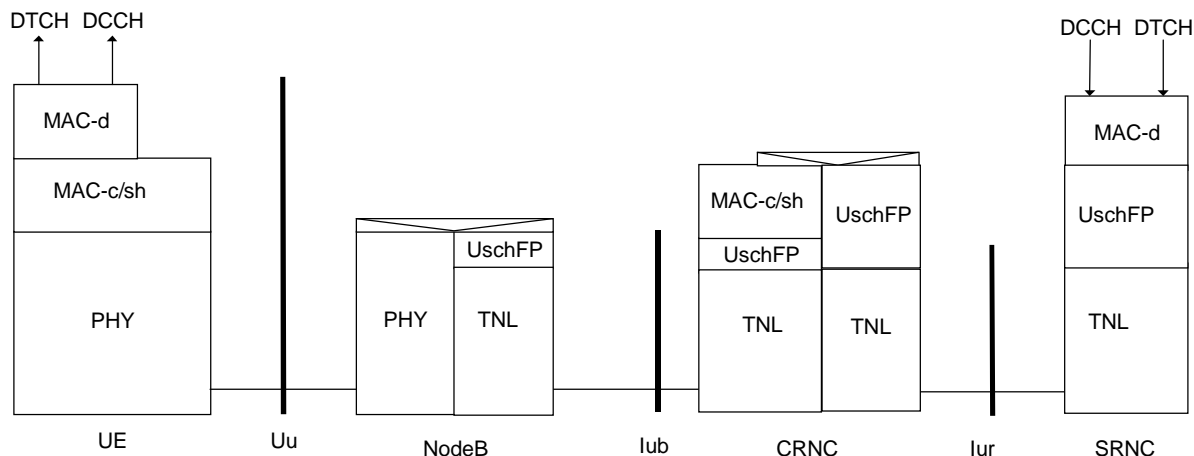

Figure 22: USCH: Separate Controlling and Serving RNC

### 11.2.7 HS-DSCH Transport Channel

Figure 23 shows the protocol model for the HS-DSCH transport channel when the Controlling and Serving RNC are co-incident. [FDD and 1.28 Mcps TDD – The protocol model in Figure 23 is applied for HS-DSCH configured for UEs in Cell\_DCH.]

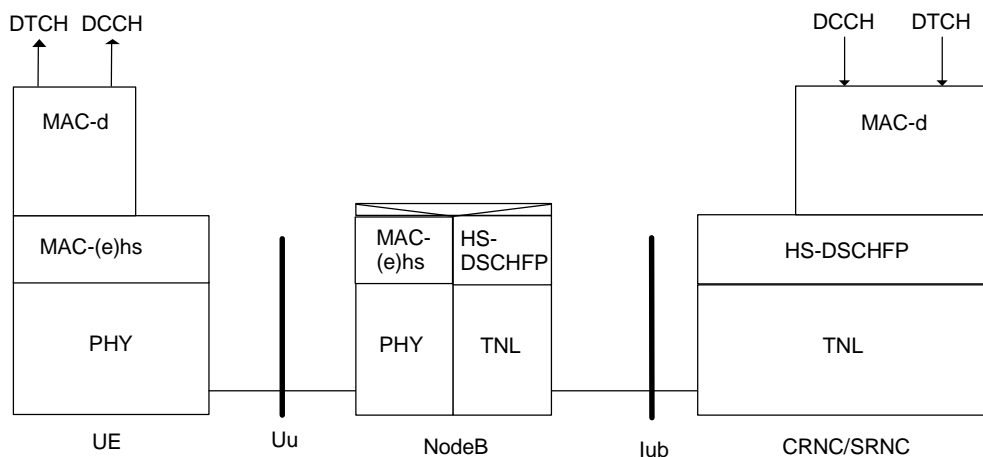

Figure 23: HS-DSCH Co-incident Controlling and Serving RNC

The High Speed MAC (MAC-hs) or Enhanced High Speed MAC (MAC-ehs) entity in the Node B transfers MAC-hs (or MAC-ehs) PDU to the peer MAC-hs (or MAC-ehs) entity in the UE over the Uu interface. The Dedicated MAC (MAC-d) entity in the RNC transfers MAC-d PDUs to the MAC-hs or MAC-ehs in the Node B using the services of the HS-DSCH Frame Protocol (HS-DSCH FP) entity. The HS-DSCH FP entity adds header information to form a HS-DSCH FP PDU that is transported to the Node B over a transport bearer.

A Relaying Function in the Node B relays the HS-DSCH frame received by HS-DSCH FP entity to the MAC-hs (or MAC-ehs) entity. HS-DSCH scheduling is performed by MAC-hs (or MAC-ehs) in the Node B.

Figure 24 shows the protocol model for the HS-DSCH transport channel with separate Controlling and Serving RNC. [FDD and 1.28 Mcps TDD – The protocol model in Figure 24 is applied for HS-DSCH configured for UEs in Cell\_DCH.] In this case, Iur HS-DSCH Frame Protocol is used to interwork the Flow Control function at the Controlling RNC with the MAC-d at the Serving RNC. Also in this case, Iub HS-DSCH Frame Protocol is used to interwork the MAC-hs (or MAC-ehs) at the Node B with the Flow Control function at the Controlling RNC.



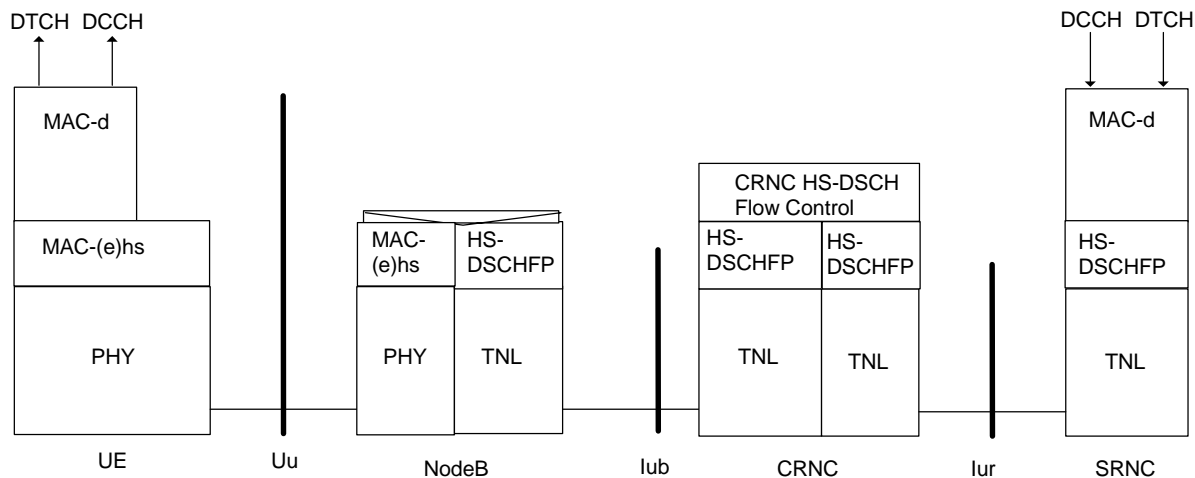

**Figure 24: HS-DSCH: Separate Controlling and Serving RNC (configuration with CRNC flow control)**

Figure 25 shows the protocol model for the HS-DSCH transport channel with the Controlling RNC user plane RNL being bypassed. [FDD and 1.28 Mcps TDD – The protocol model in Figure 25 is applied for HS-DSCH configured for UEs in Cell\_DCH.] In this case, the CRNC does not have any user plane RNL function for the HS-DSCH. MAC-d in SRNC is located directly above MAC-hs (or MC-ehs) in Node B, i.e. in the HS-DSCH user plane RNL, the SRNC is directly connected to the Node B, thus bypassing the CRNC user plane RNL. The CRNC performs only user plane TNL functions.

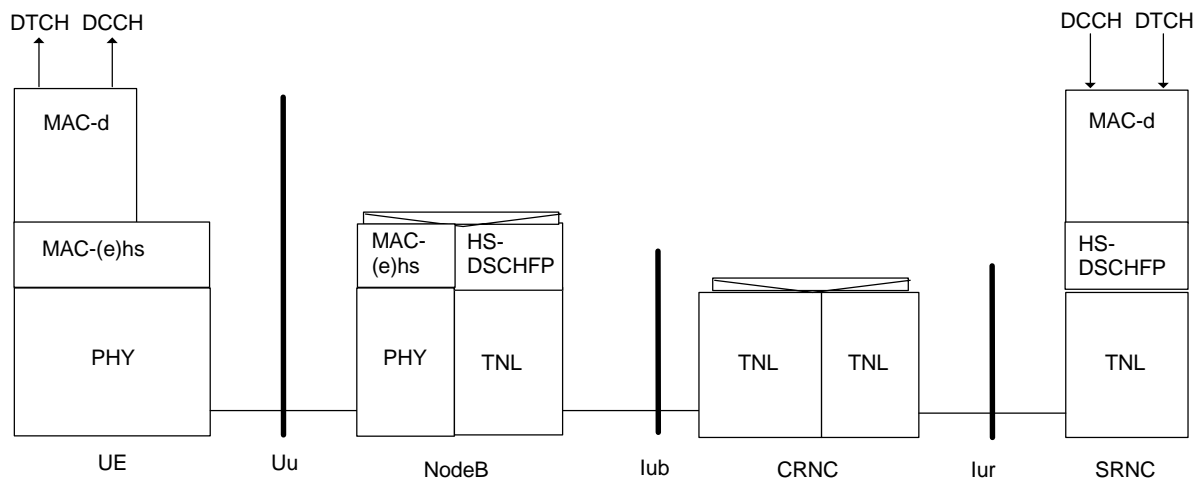

**Figure 25: HS-DSCH: Serving RNC with bypassed Controlling RNC (configuration without CRNC flow control)**

[FDD and 1.28 Mcps TDD - Figure 25A shows the protocol model for the HS-DSCH transport channel configured for UE in Cell\_FACH, Cell\_PCH and URA\_PCH, when the Controlling and Serving RNC are co-incident.

The Common MAC (MAC-c/sh/m) entity in the RNC transfers MAC-c PDU to the peer MAC-c entity in the UE using the services of the HS-DSCH Frame Protocol (HS-DSCH FP) entity.

The HS-DSCH Frame Protocol entity adds header information to form a HS-DSCH FP PDU which is transported to the Node B over a transport bearer.

The Enhanced High Speed MAC (MAC-ehs) entity in the Node B transfers MAC-ehs PDU to the peer MAC-ehs entity in the UE over the Uu interface. ]

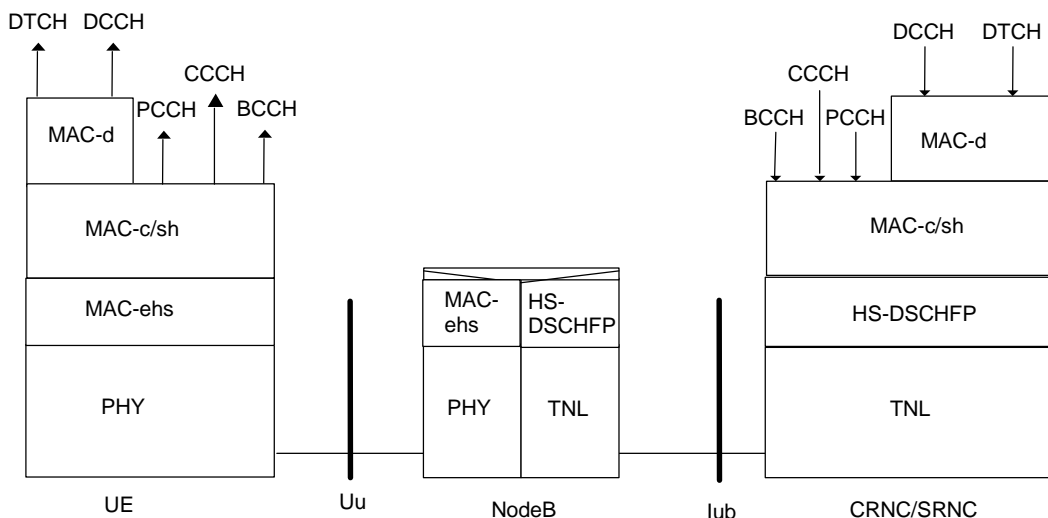

**Figure 25A: HS-DSCH configured for UE in Cell\_FACH, Cell\_PCH and URA\_PCH: Co-incident Controlling and Serving RNC (FDD and 1.28 Mcps TDD only)**

[FDD and 1.28 Mcps TDD - Figure 25B shows the protocol model for the HS-DSCH transport channel configured for UE in Cell\_FACH, Cell\_PCH and URA\_PCH, with separate Controlling and Serving RNC. In this case, Iur HS-DSCH Frame Protocol is used to interwork the Flow Control function at the MAC-c at Controlling RNC with the MAC-d at the Serving RNC. Also in this case, Iub HS-DSCH Frame Protocol is used to interwork the MAC-ehs at the Node B with the Flow Control function at the MAC-c at the Controlling RNC.]

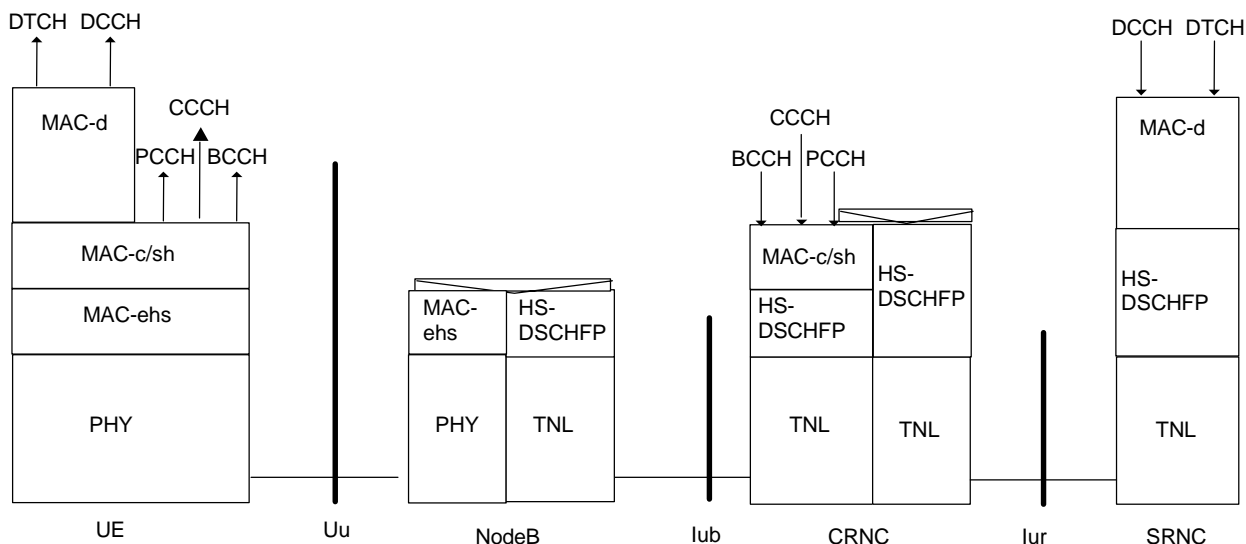

**Figure 25B: HS-DSCH configured for UE in Cell\_FACH, Cell\_PCH and URA\_PCH: Serving RNC with Separate Controlling and Serving RNC (FDD and 1.28 Mcps TDD only)**

## 11.2.8 E-DCH Transport Channel

Figure 26 shows the protocol model for the E-DCH transport channel when the Controlling and Serving RNC are co-incident. [FDD and 1.28 Mcps TDD – The protocol model in Figure 26 is applied for E-DCH configured for UEs in Cell\_DCH.]

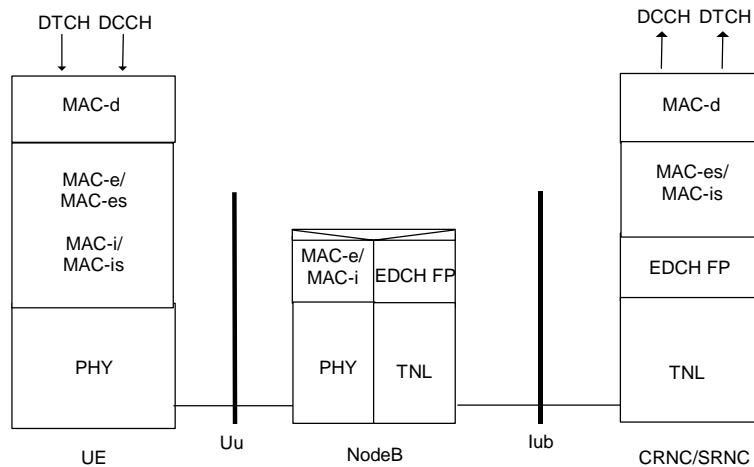

**Figure 26: E-DCH Co-incident Controlling and Serving RNC**

The E-DCH MAC (MAC-e/MAC-es)/Enhanced E-DCH MAC (MAC-i/MAC-is) entity in the UE transfers MAC-e/MAC-i PDUs to the peer MAC-e/MAC-i entity in the Node B and MAC-es/MAC-is PDUs to the peer MAC-es/MAC-is entity in the RNC using the services of the Physical Layer.

The E-DCH FP entity adds header information to form a E-DCH FP PDU that is transported to the RNC over a transport bearer.

An Interworking Function (IWF) in the Node B interworks the E-DCH frame received by the MAC-e/MAC-i entity into the E-DCH Frame Protocol (E-DCH FP) entity. E-DCH scheduling is performed by MAC-e/MAC-i in the Node B and reordering is performed by MAC-es/MAC-is in the RNC.

Figure 27 shows the protocol model for the E-DCH transport channel with separate Controlling and Serving RNC. [FDD and 1.28 Mcps TDD – The protocol model in Figure 27 is applied for E-DCH configured for UEs in Cell\_DCH.] In this case, the CRNC does not have any user plane RNL function for the E-DCH. MAC-es/MAC-is in SRNC is located directly above MAC-e/MAC-is in Node B, i.e. in the E-DCH user plane RNL, the SRNC is directly connected to the Node B, thus bypassing the CRNC user plane RNL. The CRNC performs only user plane TNL functions.

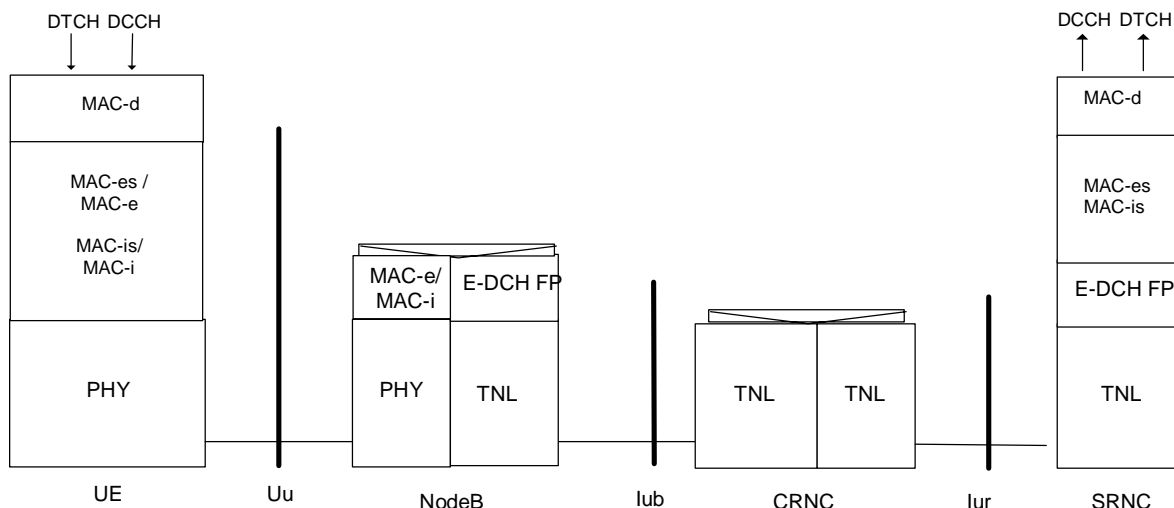
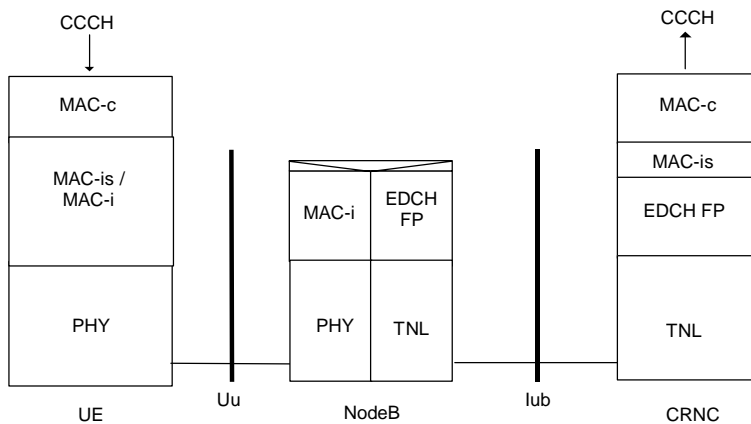

**Figure 27: E-DCH: Separate Controlling and Serving RNC**

[FDD and 1.28 Mcps TDD - Figure 28 shows the protocol model for the E-DCH transport channel configured for UE in Cell\_FACH for CCCH transmission.

The E-DCH MAC (MAC-i/MAC-is) entity in the UE transfers MAC-i and MAC-is PDUs to the peer MAC-i in the Node B and and MAC-is entity in the CRNC.

The E-DCH FP entity adds header information to form a E-DCH FP PDU that is transported to the RNC over a transport bearer.]



**Figure 28: E-DCH configured for UE in Cell\_FACH(CCCH case)(FDD and 1.28 Mcps TDD only)**

[FDD and 1.28 Mcps TDD - Figure 29 shows the protocol model for the E-DCH transport channel configured for UE in Cell\_FACH for DCCH and DTCH transmission when the Controlling and Serving RNC are co-incident.

The E-DCH MAC (MAC-i/MAC-is) entity in the UE transfers MAC-i PDUs to the peer MAC-i entity in the Node B and MAC-is PDUs to the peer MAC-is entity in the RNC using the services of the Physical Layer.

The E-DCH FP entity adds header information to form anE-DCH FP PDU that is transported to the RNC over a transport bearer.

An Interworking Function (IWF) in the Node B interworks the E-DCH frame received by the MAC-i entity into the E-DCH Frame Protocol (E-DCH FP) entity. E-DCH scheduling is performed by MAC-i in the Node B and reordering is performed by MAC-is in the RNC.]

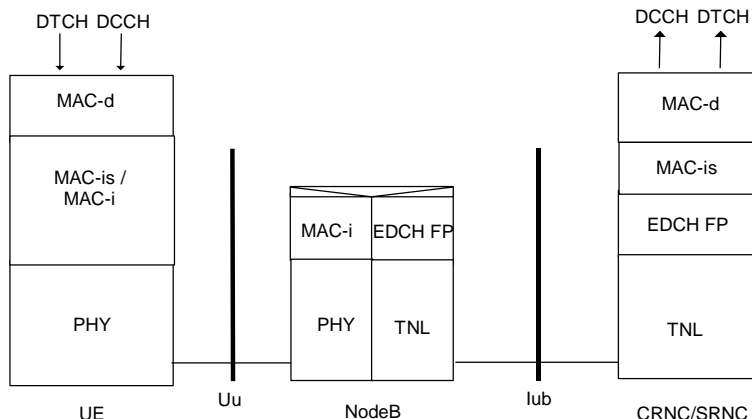

**Figure 29: E-DCH configured for UE in Cell\_FACH (DCCH/DTCH case) :Co-incident Controlling and Serving RNC (FDD and 1.28 Mcps TDD only)**

[FDD and 1.28 Mcps TDD - Figure 30 shows the protocol model for the E-DCH transport channel configured for UE in Cell\_FACH for DCCH and DTCH transmission, with separate Controlling and Serving RNC.

An Interworking Function (IWF) in the CRNC interworks the E-DCH data frame received from Node B into the Iur E-DCH Frame Protocol (E-DCH FP) entity.]

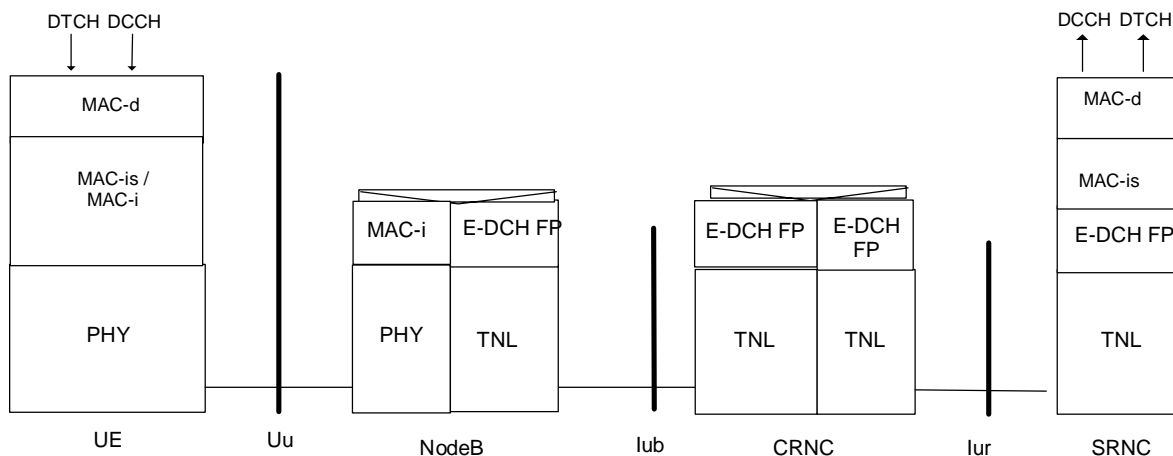

**Figure 30: E-DCH configured for UE in Cell\_FACH (DCCH/DTCH case): Separate Controlling and Serving RNC (FDD and 1.28 Mcps TDD only)**

## 12 UTRAN Performance Requirements

### 12.1 UTRAN delay requirements

Void.

---

## Annex A (informative): SPID ranges and mapping of SPID values to cell reselection and inter-RAT/inter frequency handover priorities

Ranges of SPID (Subscriber Profile ID for RAT/Frequency Priority) values, respectively Operator Specific and Reference values and the mapping at RNS of Reference SPID values to cell reselection and inter-RAT/inter frequency handover priorities are defined in TS 36.300 [35].

## Annex A2 (Informative): Deployment of Extended Identifiers

### A2.1 RNC Sizing Changes

#### A2.1.1 U-RNTI Considerations

The U-RNTI of 32 bits is normally divided in the following way:

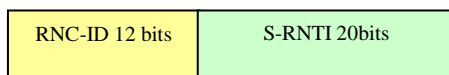

**Figure A2.1.1.1: RNC Side, normal split of U-RNTI in RNC-ID and S-RNTI**

When a large number of small RNCs were considered (HSPA+ cells), then extended RNC-ID was added, this took bits from the S-RNTI reducing this to 16bits thus:

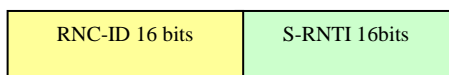

**Figure A2.1.1.2: RNC-Side, split of U-RNTI in RNC-ID and S-RNTI in the case of many small RNCs deployed**

Whilst this limited the S-RNTIs available to a RNC to 65k, as the RNCs were smaller this was acceptable, and allowed the addressing of 65k RNCs (per PLMN).

Also related is the cell identity, containing the cell id and the RNC-ID

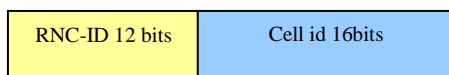

**Figure A2.1.1.3: RNC Side, normal split of Cell identity in RNC-ID and Cell id.**

Or for extended RNC-ID

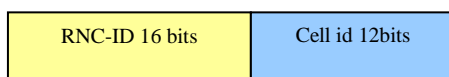
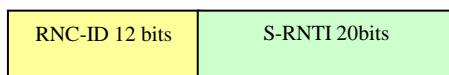

**Figure A2.1.1.4: RNC Side, split of Cell identity in RNC-ID and CELL ID in case of extended RNC-ID (many small RNCs deployed)**

Rules are applied to handle extended RNC-ID in relation to the addressing of RNCs in Clause A2.2.

For extending the S-RNTI to handle larger number of UEs.

The UE side is unchanged:



**Figure A2.1.1.5: UE Side, Normal split of U-RNTI in RNC-ID and S-RNTI**

The RAN side uses a shorter RNC-ID and extended S-RNTI to give 4x increase in the number of UEs that can be supported on a RNC.

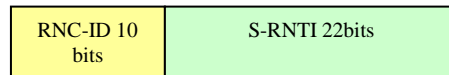

**Figure A2.1.1.6: UE Side, Split of U-RNTI in RNC-ID and S-RNTI in case of large number of UEs deployed.**

Rules and methods to achieve this extension are in Clause A2.1.2 and A2.1.3.

## A2.1.2 Extend S-RNTI and reduce RNC-ID: Solution 1

In this solution the S-RNTI is extended by 2 bits and the RNC-ID reduced by 2 bits. This gives an increased number of UE supported to  $2^{22}$ , but a reduced number of RNC-IDs available at 1024 ( $2^{10}$ ).

UE Side

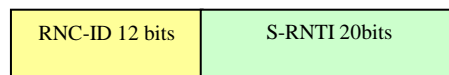

**Figure A2.1.2.1: UE Side, Normal split of U-RNTI in RNC-ID and S-RNTI**

RAN Side

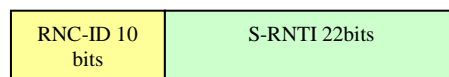

**Figure A2.1.2.2: RNC Side, Extended S-RNTI and reduced RNC-ID ranges**

Although this approach increases by 4 the number of SRNTIs available, new rules are needed to handle addressing large RNCs with 10bit RNC-IDs. It is also incompatible with extended RNC-ID. The co-existence of extended RNC-ID and extended S-RNTI in one network may not be possible or the rules would become exceedingly complex.

### Reallocation of U-RNTI to allow more S-RNTI

Initially we look at the current restrictions in the standards.

In TS25.331 Section 8.1.1.6.5 (System Information Block type 5 and 5bis), UE checks the 12bits of RNC-ID for performing URA update. Therefore the UE is using the 12bits of the RNC-Id in the U\_RNTI to check for change in RNC and perform URA update.

- 2> if the UE is in CELL\_PCH or URA\_PCH state:
  - 3> for FDD and for 1.28 Mcps TDD, if the UE supports HS-DSCH reception in CELL\_PCH and URA\_PCH state; and
  - 3> if IE "HS-DSCH paging system information" is included:
    - 4> if this IE is not currently stored; and
    - 4> if the value of the IE "SRNC identity" in the variable U\_RNTI is not equal to the 12 MSBs of the received IE "Cell identity" in System Information Block type 3; and
    - 4> if the UE is in URA\_PCH state:
      - 5> initiate the URA update procedure as specified in subclause 8.3.1, using the cause "periodic URA update".

Due to this, RNC with Extended S-RNTI implementation would make sure to design the U-RNTI, to avoid unnecessary URA updates. This can be done by ensuring that the 2 MSB of the extended the S-RNTI are the same for UEs in the same area.

## A2.1.3 Pooled RNCs: Solution 2

In this solution a large RNC consists of 4 (or 2) RNCs each with a 12 bit RNC-ID. This could be considered a version of Solution 1, but here the large RNC is handled as a single RNC where the 2 LSBs of the RNC-ID are zero.



UE Side

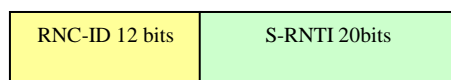

Figure A2.1.3.1: UE Side, Normal split of U-RNTI in RNC-ID and S-RNTI

RAN Side

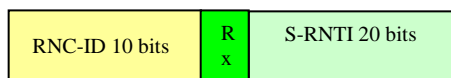

Figure A2.1.3.1: RNC Side, RNC-ID split into extended RNC-ID and sub-RNC indicator.

On the RAN side only the 10 MSBs are used for routing/addressing RNCs. Large RNC RNC-IDs are identified by RNC ID range and the 2 LSBs of RNC-ID being zero. CN routing and RNC routing would need updating to ensure that the mobility to the correct RNC occurs based on 10 bit RNC-ID. Other non-pooled RNCs will be routed in the normal way. This has perhaps more impact on the network than solution 1 but the large RNC would support the extended number of UEs, as it acts like 4 RNCs.

## A2.2 RNC ID Extension

The problem of insufficient RNC ID number space was identified and it was agreed to extend the range of the RNC ID. As a solution for the extension of the number space, it was agreed to increase the bit length of the RNC-ID from 12bits to 16bits by introducing a new ID with 16bits-length, and to introduce an *Extended RNC ID* IE into the relevant specifications. While the maximum number of RNCs within one PLMN in the current specification is 4096, the introduction of the new IE allows a maximum of 65536 (4096:legacy RNC ID + 61440: extended RNC-ID) RNCs to be deployed in one PLMN in the future.

### A2.2.1 Solution for RNC-ID Extension

The Extended RNC-ID is only introduced into the network internal signalling specifications, e.g. RANAP between RNC and CN and does not require any changes to the RRC protocol so that legacy UEs can operate in an RNS which is configured to use an extended RNC ID.

This is possible by partitioning the 32bits of the U-RNTI in a different manner in RNS which is configured to use the extended RNC-ID. Thus some bits of the S-RNTI (20bits) part of the U-RNTI are used to extend the SRNC-ID part in the RNS using the extended RNC-ID. Therefore, the extension for the SRNC-ID in the network is not visible for the UE. As specified today, the UE always treats the 32 bit together as U-RNTI.

UE Side



RAN Side



Figure A2.2.1.1: Interpretation of U-RNTI in UE side and RAN side is configured to use the extended RNC ID

As the same logic is applied for Cell Identity, 4MSB of the 16bit C-ID are used as an extension of RNC-ID. Thus under the RNC using the extended RNC-ID, the bits available for the C-ID are reduced to 12bits (4096).

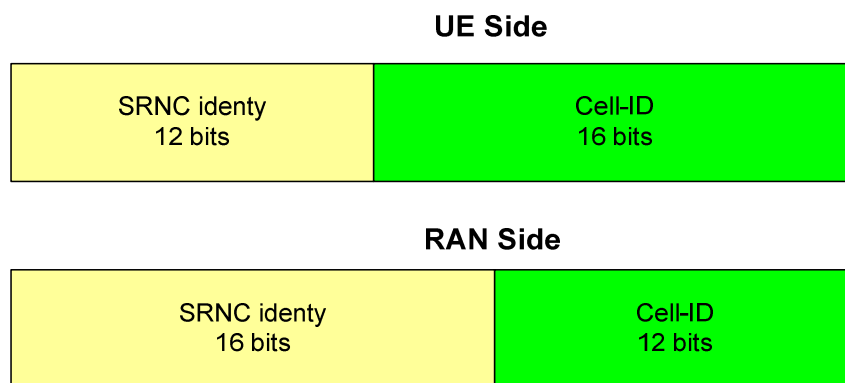

**Figure A2.2.1.2: Interpretation of Cell identity (= UC-ID) in UE side and RAN side is configured to use the extended RNC ID**

The number of UEs and cells in one RNS using the extended RNC-ID are different from the one using the current RNC ID as shown in the table below since the 4bits used for the S-RNTI and Cell ID are used as part of extended RNC-ID in the RNS.

	<b>Current RNC-ID</b>	<b>Extended RNC-ID</b>
The number of UEs in RNS	1 048 576	65 536
The number of UEs for Inter-RAT HO at once in RNS	1 024	64
The number of cells in RNS	65 536	4 096

## A2.2.2 Rules for Configuration

There are some limitations for configuring network when the extended RNC-ID scheme is used. The network configuration shall follow all four rules as stated below together.

### Explanation of terms

**Legacy RNC/CN:** RNC/CN do not comprehend/support the extended RNC-ID IE/Scheme, e.g. Pre-Rel7 RNC/CN.

**Upgraded RNC/CN:** RNC/CN comprehend/support the extended RNC-ID IE/Scheme and can distinguish which RNC-ID scheme are used in the received message or sending message based on the stored configuration data.

### Rule1):

In case relocation needs to be supported to/from an RNC using the extended RNC-ID, it is recommended to connect the source and target RNCs to the same upgraded CN to reduce the number of upgraded CN. In case CN cannot be upgraded, it is recommended to use legacy RNC-ID under that CN. (Example in Figure A2.2.2.1).

### Rule2):

Not configure the Iur interface connection between legacy RNC and upgraded RNC using the extended RNC-ID.

### Rule3):

In case RNCs with legacy RNC-ID and RNCs with extended RNC-ID co-exist in the network, configure the legacy RNC-ID so that legacy RNC-ID will not be the same as the 12 bit of MSB of any of extended RNC-ID to which the legacy RNC may have Iur connection. (See the Figure A2.2.2.3 and A2.2.2.4).

### Rule4):

In case a URA spanned over multiple RNCs with extended RNC-ID and the RNCs have different capability on HS-DSCH reception in URA\_PCH state, the RNCs capable of HS-DSCH reception in URA\_PCH state shall not have the same 12bit MSB in their extended RNC-ID compared to the RNCs not capable of HS-DSCH reception in URA\_PCH. (See Figures A2.2.2.5 and A2.2.2.6).

### Depiction of Configuration Rules

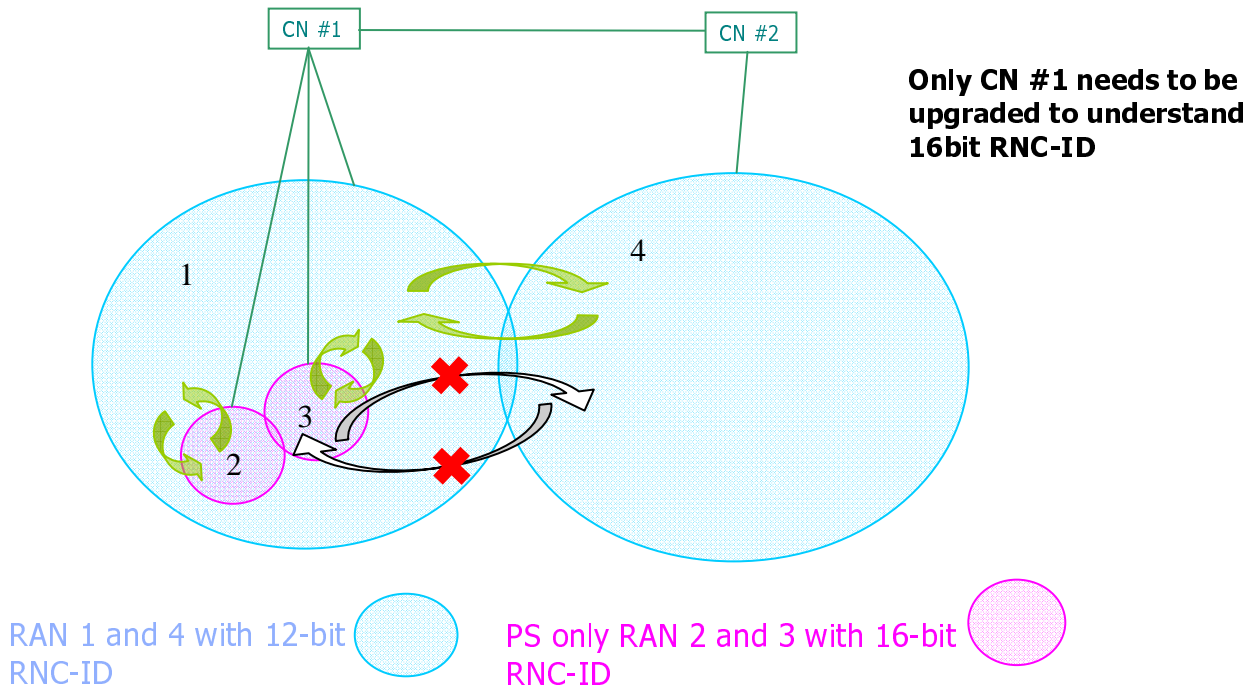

Figure A2.2.2.1: Configuration example for Rule 1 and 2

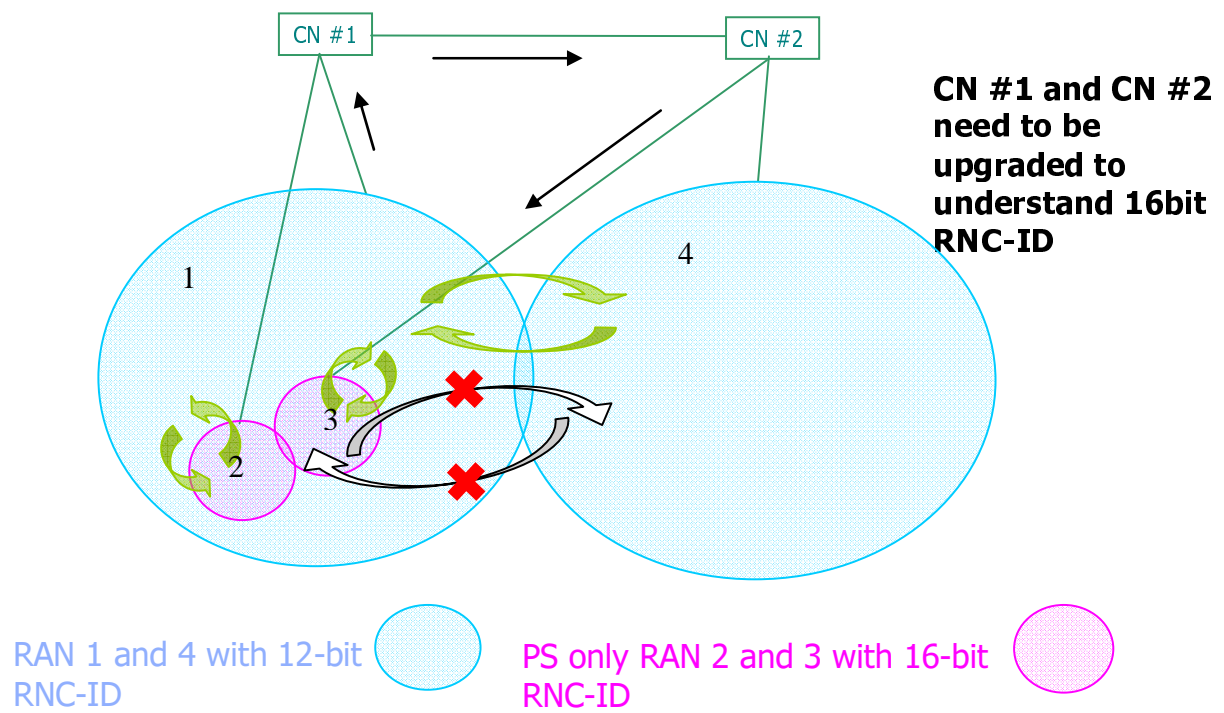

Figure A2.2.2.2: Configuration example for Rule 1 and 2.

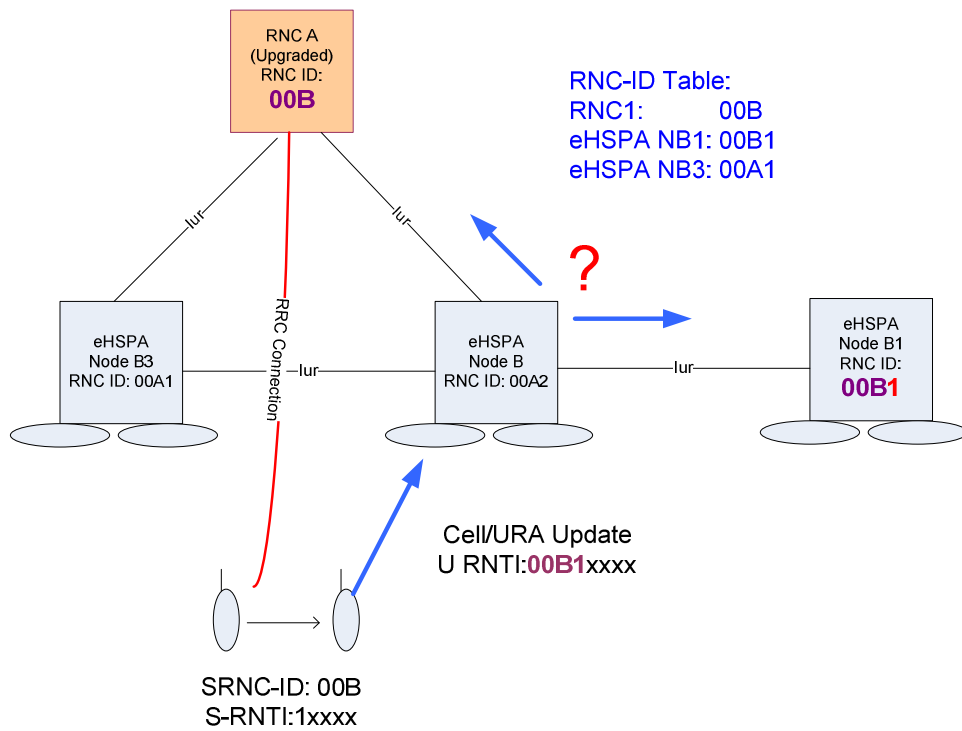

Figure A2.2.2.3: Problematic configuration example (does not follow Rule3)

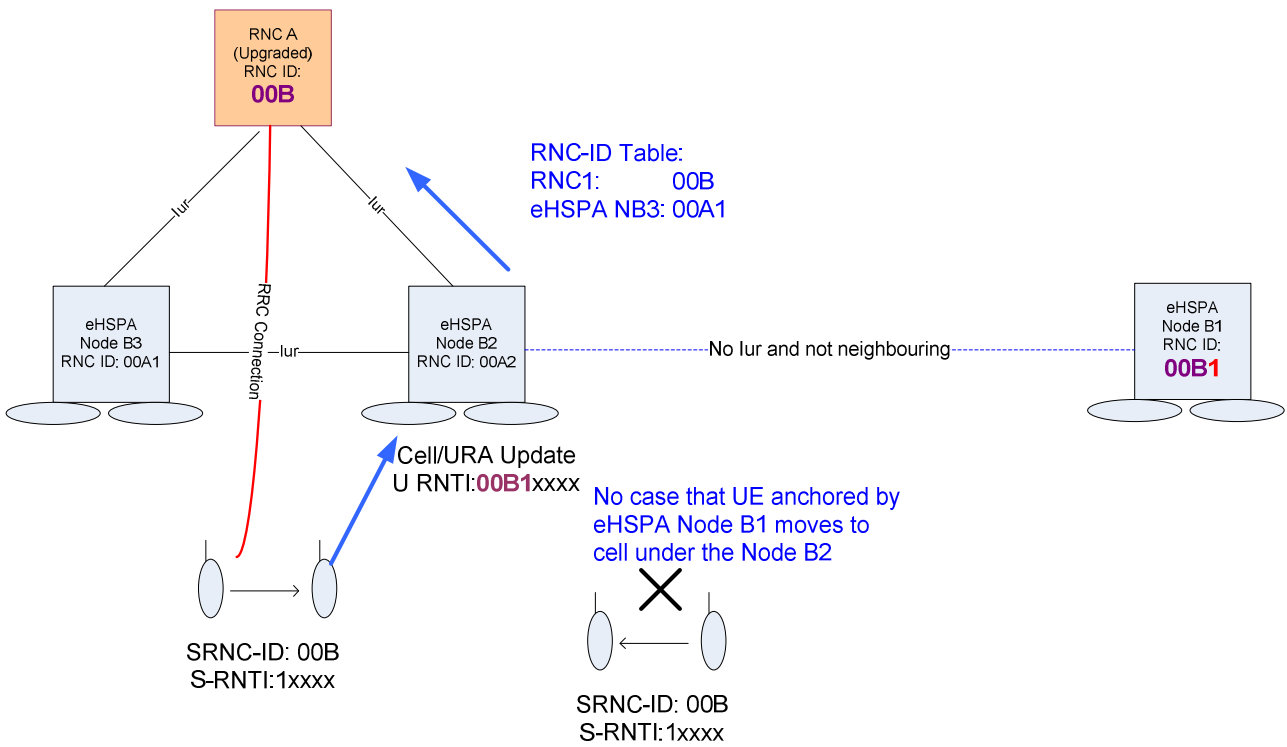

Figure A2.2.2.4: Configuration example for Rule3

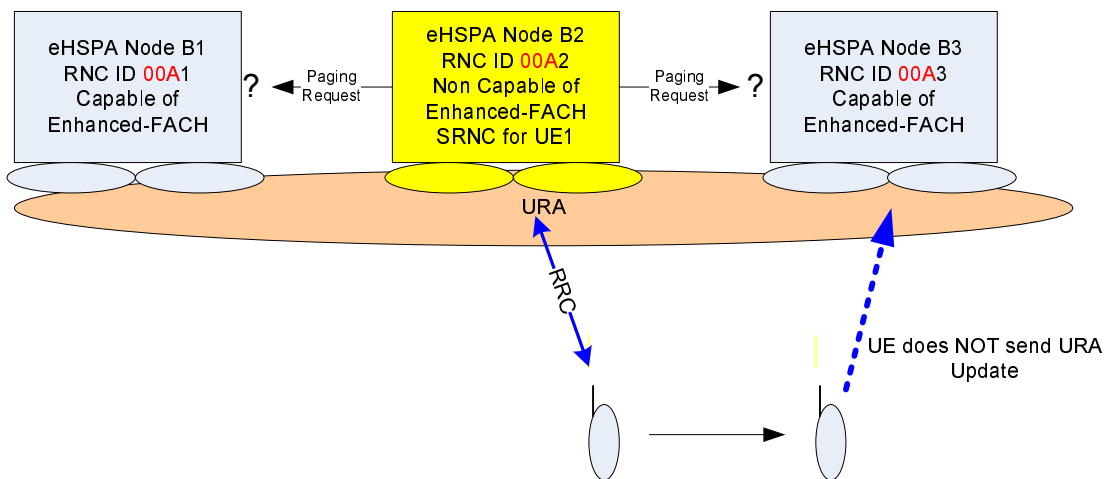

Figure A2.2.2.5 Problematic configuration example (does not follow Rule4)

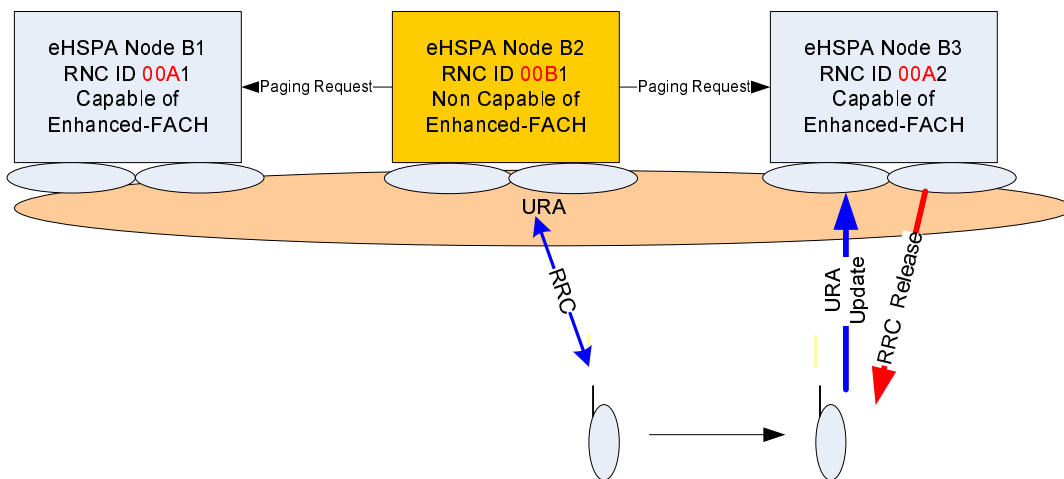

Figure A2.2.2.6 Configuration example for Rule4

### A2.2.3 Configuration Example

The RNC ID configuration example below is following the rules listed in A2.2.2 and showing the configuration in Figure A2.2.2.2 in a large scale.

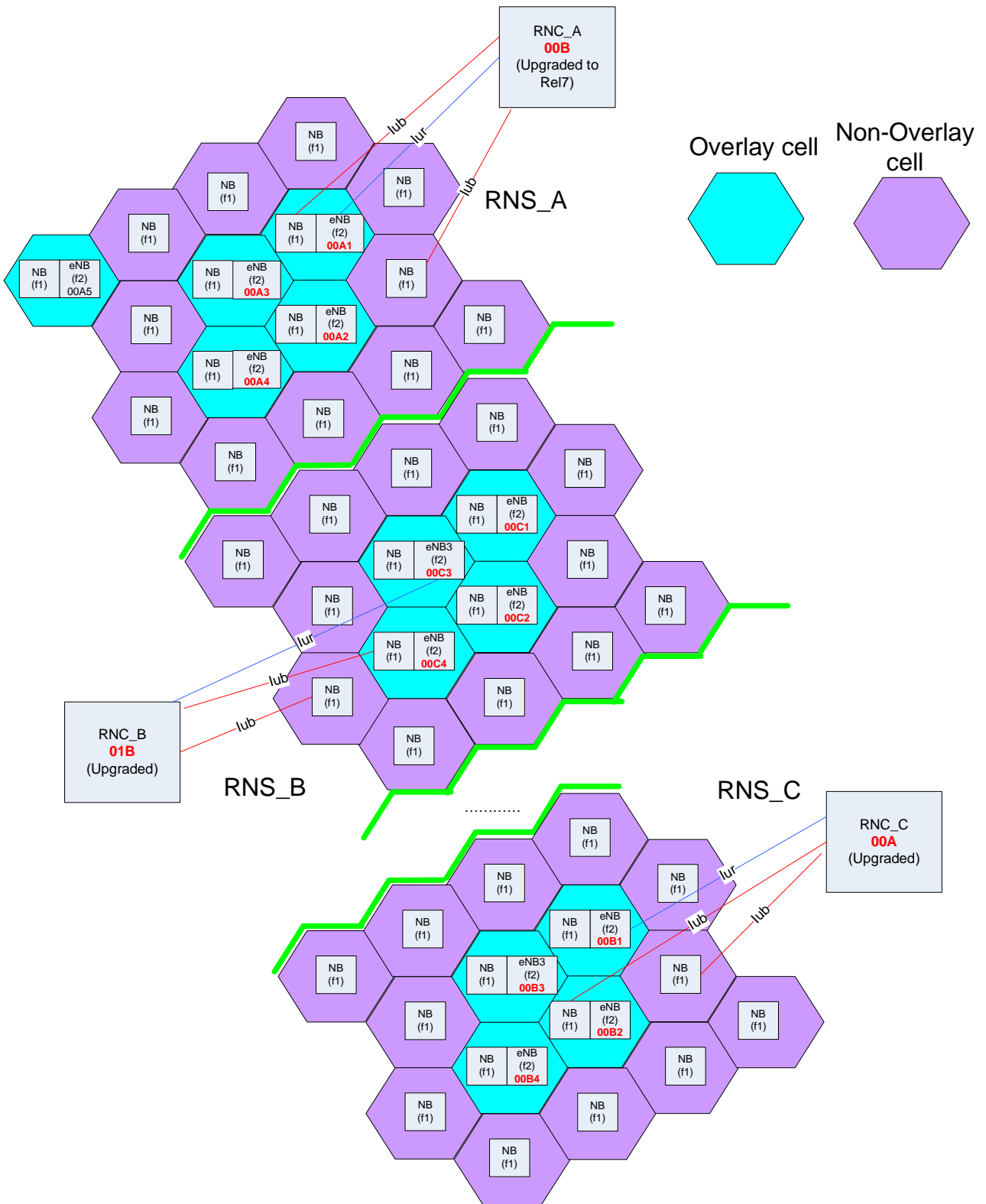

Figure A2.2.3.1: Valid RNC ID Configuration Example

## Annex B (informative): Change history

Change history					
TSG RAN#	Version	CR	Tdoc RAN	New Version	Subject/Comment
RAN_05	-	-	-	3.0.0	Approved at TSG RAN #5 and placed under Change Control
RAN_06	3.0.0	-	RP-99735	3.1.0	Approved at TSG RAN #6
RAN_06	3.0.0	-	RP-99736	3.1.0	Approved at TSG RAN #6
RAN_06	3.0.0	-	RP-99737	3.1.0	Approved at TSG RAN #6
RAN_06	3.0.0	-	RP-99738	3.1.0	Approved at TSG RAN #6
RAN_07	3.1.0	-	RP-000073	3.2.0	Approved at TSG RAN #7
RAN_08	3.2.0	-	RP-000231	3.3.0	Approved at TSG RAN #8
RAN_09	3.3.0	013 014 015 016 017	RP-000370	3.4.0	Approved at TSG RAN #9
RAN_10	3.4.0	018 019	RP-000607	3.5.0	Approved at TSG RAN #10
RAN_11	3.5.0	020 021	RP-010107	3.6.0	Approved at TSG RAN #11

Change history							
Date	TSG #	TSG Doc.	CR	Rev	Subject/Comment	Old	New
March 01	11	RP-010164	23	1	Approved at TSG RAN #11 and placed under Change Control	-	4.0.0
June 01	12	RP-010370	025, 028, 032		Approved at TSG RAN #12	4.0.0	4.1.0
June 01	12	RP-010389	026, 029		Approved at TSG RAN #12	4.0.0	4.1.0
June 01	12	RP-010403	030		Approved at TSG RAN #12 and placed under Change Control	4.1.0	5.0.0
09/2001	13	RP-010575	033		Uplink power control for LCR TDD	5.0.0	5.1.0
09/2001	13	RP-010575	038		Clarification of coordinated DCHs	5.0.0	5.1.0
03/2002	15	RP-020221	046		New UE identifier for MAC-c/sh multiplexing for DSCH	5.1.0	5.2.0
03/2002	15	RP-020189	044	2	Introduction of IP Transport in UTRAN	5.1.0	5.2.0
03/2002	15	RP-020190	039	2	HSDPA Additions for REL-5	5.1.0	5.2.0
03/2002	15	RP-020195	045	1	NNSF Functional Description	5.1.0	5.2.0
06/2002	16	RP-020422	047		HSDPA-related changes	5.2.0	5.3.0
06/2002	16	RP-020421	048		Corrections on ATM-IP interoperability scenarios	5.2.0	5.3.0
06/2002	16	RP-020399	051		New UE identifier for Shared Channel handling for TDD DSCH/USCH	5.2.0	5.3.0
06/2002	16	RP-020421	052		Introduction of IP transport in UTRAN	5.2.0	5.3.0
06/2002	16	RP-020421	053	2	Independence of RNL and TNL	5.2.0	5.3.0
09/2002	17	RP-020605	055	1	Clarification on ALCAP Identifiers	5.3.0	5.4.0
09/2002	17	RP-020627	056	1	Introduction of Iur-g	5.3.0	5.4.0
09/2002	17	RP-020625	057	1	Introduction of the Access Control Function: SNA	5.3.0	5.4.0
09/2002	17	RP-020628	059		Introduction of HS-DSCH RNTI in TS25.401	5.3.0	5.4.0
12/2002	18	RP-020750	062		Definition of URA	5.4.0	5.5.0
12/2002	18	RP-020764	064	1	Corrections to the SNA Access Control Function	5.4.0	5.5.0
03/2003	19	RP-030084	065		CR on revising the definition of SAS to support all REL-4 UE positioning methods	5.5.0	6.0.0
06/2003	20	RP-030317	068	1	Correction to HS-DSCH transport in case of SRNC not coincident with DRNC and without flow control in the DRNC	6.0.0	6.1.0
12/2003	22	RP-030675	076	1	NAS/AS issue for shared networks in connected mode	6.1.0	6.2.0
06/2004	24	RP-040182	084	1	Introduction of Iu and Iur support of Network Assisted Cell Change from UTRAN to GERAN	6.2.0	6.3.0
06/2004	24	RP-040254	086		Completion of the REL-5 IP Transport WI	6.2.0	6.3.0
09/2004	25	RP-040303	087	1	Introduction of Iuant into UTRAN architecture for control of RET Antennas	6.3.0	6.4.0
09/2004	25	RP-040297	091		Terminology correction of IP ALCAP CR	6.3.0	6.4.0
12/2004	26	RP-040439	92		Support of MOCN and GWCN configurations in UTRAN	6.4.0	6.5.0
12/2004	26	RP-040440	94	1	Introduction of E-DCH in 25.401	6.4.0	6.5.0
12/2004	26	RP-040437	95	1	CR for Introducing MBMS in 25.401	6.4.0	6.5.0
06/2005	28	RP-050225	97		Feature Cleanup: Removal of CPCH	6.5.0	6.6.0
06/2005	28	RP-050222	99		Feature clean-up: Removal of DSCH (FDD mode)	6.5.0	6.6.0

09/2005	29	RP-050435	101		E-DCH Protocol Model	6.6.0	6.7.0
03/2006	31	RP-060072	100	2	Enabling the Providing of Velocity	6.7.0	7.0.0
03/2006	31	RP-060073	102	1	Introduction of 7.68Mcps TDD option	6.7.0	7.0.0
09/2006	33	RP-060511	105		Introduction of 3.84 Mcps and 7.68Mcps TDD Enhanced Uplink	7.0.0	7.1.0
09/2006	33	RP-060499	107	2	MBMS Transport Identifiers	7.0.0	7.1.0
12/2006	34	RP-060698	109	1	Delete reference to "MBMS UTRAN Cell Group Identifier"	7.1.0	7.2.0
12/2006	34	RP-060837	110	1	Consistency of Specification Notations	7.1.0	7.2.0
03/2007	35	RP-070058	111		Introduction of TMA	7.2.0	7.3.0
03/2007	35	RP-070062	112		Introduction of 1.28 Mcps TDD Enhanced Uplink	7.2.0	7.3.0
06/2007	36	RP-070328	113	2	Introduction of Enhanced Cell_FACH state feature	7.3.0	7.4.0
09/2007	37	RP-070568	114	1	Introduction of GANSS (Galileo and Additional Navigation Satellite Systems)	7.4.0	7.5.0
09/2007	37	RP-070650	115	1	Introduction of multi-frequency for 1.28Mcps TDD in 25.401	7.4.0	7.5.0
06/2008	40	RP-080297	116		MAC-ehs in CELL_DCH	7.5.0	7.6.0
06/2008	40	RP-080306	118		Introduction of Improved L2 for Uplink	7.6.0	8.0.0
09/2008	41	RP-080590	122	1	The supplement of IPv4 encoding in NSAP structure	8.0.0	8.1.0
09/2008	41	RP-080587	123		Introduction of Enhanced Uplink in Cell_FACH	8.0.0	8.1.0
12/2008	42	RP-080849	124	1	Enable to dynamically control the MBMS services in MBSFN	8.1.0	8.2.0
12/2008	42	RP-080850	125	1	Introduction of the Enhanced CELL_FACH, CELL_PCH, URA_PCH state for 1.28Mcps TDD	8.1.0	8.2.0
12/2008	42	RP-080840	126		Introduction of Enhanced Relocation	8.1.0	8.2.0
12/2009	-	-	-	-	Created version 9.0.0 based on version 8.2.0	8.2.0	9.0.0
03/2010	47	RP-100229	128	1	SPID description and implementation guidelines in UTRAN	9.0.0	9.1.0
12/2010	50	RP-101389	131		Introduction of the SIPTO at Iu-PS Function	9.1.0	10.0.0
12/2010	50	RP-101272	133	1	Adding support for ECN in UTRA	9.1.0	10.0.0
03/2011	SP-49	SP-100629			Clarification on the use of References (TS 21.801 CR#0030)	10.0.0	10.1.0
03/2011	51	RP-110230	136	1	Support for MDT	10.0.0	10.1.0
06/2011	52	RP-110684	137	1	Correction of references	10.1.0	10.2.0
06/2011	52	RP-110694	138	3	Introduction of Enhancements of Iur-g Interface	10.1.0	10.2.0
09/2012	57	RP-121140	139	3	EAB for CN Overload Control	10.2.0	11.0.0
12/2012	58	RP-121736	140	2	Documenting the Description of Extended S-RNTI and RNC-ID operation	11.0.0	11.1.0



---

## History

<b>Document history</b>		
V11.0.0	October 2012	Publication
V11.1.0	January 2013	Publication