

# ETSI TS 125 323 V4.0.0 (2001-03)

---

*Technical Specification*

## **Universal Mobile Telecommunications System (UMTS); Packet Data Convergence Protocol (PDCP) Specification (3GPP TS 25.323 version 4.0.0 Release 4)**

---



---

**Reference**

RTS/TSGR-0225323Uv4

---

**Keywords**

UMTS

**ETSI**

650 Route des Lucioles  
F-06921 Sophia Antipolis Cedex - FRANCE

---

Tel.: +33 4 92 94 42 00 Fax: +33 4 93 65 47 16

Siret N° 348 623 562 00017 - NAF 742 C  
Association à but non lucratif enregistrée à la  
Sous-Préfecture de Grasse (06) N° 7803/88

---

**Important notice**

Individual copies of the present document can be downloaded from:

<http://www.etsi.org>

The present document may be made available in more than one electronic version or in print. In any case of existing or perceived difference in contents between such versions, the reference version is the Portable Document Format (PDF). In case of dispute, the reference shall be the printing on ETSI printers of the PDF version kept on a specific network drive within ETSI Secretariat.

Users of the present document should be aware that the document may be subject to revision or change of status. Information on the current status of this and other ETSI documents is available at <http://www.etsi.org/tb/status/>

If you find errors in the present document, send your comment to:  
editor@etsi.fr

---

**Copyright Notification**

No part may be reproduced except as authorized by written permission.  
The copyright and the foregoing restriction extend to reproduction in all media.

© European Telecommunications Standards Institute 2001.

All rights reserved.

---

## Intellectual Property Rights

IPRs essential or potentially essential to the present document may have been declared to ETSI. The information pertaining to these essential IPRs, if any, is publicly available for **ETSI members and non-members**, and can be found in ETSI SR 000 314: "*Intellectual Property Rights (IPRs); Essential, or potentially Essential, IPRs notified to ETSI in respect of ETSI standards*", which is available from the ETSI Secretariat. Latest updates are available on the ETSI Web server (<http://www.etsi.org/ipr>).

Pursuant to the ETSI IPR Policy, no investigation, including IPR searches, has been carried out by ETSI. No guarantee can be given as to the existence of other IPRs not referenced in ETSI SR 000 314 (or the updates on the ETSI Web server) which are, or may be, or may become, essential to the present document.

---

## Foreword

This Technical Specification (TS) has been produced by the ETSI 3<sup>rd</sup> Generation Partnership Project (3GPP).

The present document may refer to technical specifications or reports using their 3GPP identities, UMTS identities or GSM identities. These should be interpreted as being references to the corresponding ETSI deliverables.

The cross reference between GSM, UMTS, 3GPP and ETSI identities can be found under [www.etsi.org/key](http://www.etsi.org/key).

# Contents

Foreword .....	4
1 Scope.....	5
2 References.....	5
3 Abbreviations.....	5
4 General.....	6
4.1 Objective .....	6
4.2 Overview on sublayer architecture .....	6
5 Functions.....	7
5.1 Header Compression .....	7
5.1.1 Assignment of PID values .....	8
5.1.2 IP Header Compression (RFC 2507) .....	9
5.1.2.1 Context identifiers .....	9
5.1.2.2 Assignment of PID values for RFC 2507 .....	9
5.1.3 Robust Header Compression (RFC 3095) .....	9
5.1.3.1 Context identifiers .....	9
5.1.3.2 Assignment of PID values for RFC 3095 with CIDs in PDCP PDU Header .....	9
5.1.3.3 Assignment of PID values for RFC 3095 packet format .....	10
5.1.3.4 RFC 3095 Segmentation.....	10
5.1.3.5 Protocol Parameters .....	10
5.2 Void.....	11
5.3 Data Transfer.....	11
5.3.1 Data transfer over acknowledged mode RLC.....	11
5.3.2 Data transfer over unacknowledged and transparent mode RLC.....	12
5.4 SRNS Relocation.....	12
5.4.1 PDCP Sequence Numbering.....	12
6 Services.....	13
6.1 Services provided to upper layers.....	13
6.2 Services expected from RLC layer.....	13
7 Elements for layer-to-layer communication .....	13
7.1 Primitives between PDCP and upper layers .....	13
8 Elements for peer-to-peer communication.....	15
8.1 Protocol data units .....	15
8.2 Formats.....	15
8.2.1 PDCP-No-Header PDU .....	15
8.2.2 PDCP Data PDU.....	15
8.2.3 PDCP SeqNum PDU .....	15
8.3 Parameters .....	16
8.3.1 PDU Type.....	16
8.3.2 PID.....	16
8.3.3 Data.....	16
8.3.4 Sequence number.....	16
9 Handling of unknown, unforeseen and erroneous protocol data .....	17
<b>Annex A (informative): Change history.....</b>	<b>18</b>

---

# Foreword

This Technical Specification (TS) has been produced by the 3<sup>rd</sup> Generation Partnership Project (3GPP).

The contents of the present document are subject to continuing work within the TSG and may change following formal TSG approval. Should the TSG modify the contents of the present document, it will be re-released by the TSG with an identifying change of release date and an increase in version number as follows:

Version x.y.z

where:

- x the first digit:
  - 1 presented to TSG for information;
  - 2 presented to TSG for approval;
  - 3 or greater indicates TSG approved document under change control.
- y the second digit is incremented for all changes of substance, i.e. technical enhancements, corrections, updates, etc.
- z the third digit is incremented when editorial only changes have been incorporated in the document.

---

# 1 Scope

The present document provides the description of the Packet Data Convergence Protocol (PDCP).

PDCP provides its services to the NAS at the UE or the relay at the Radio Network Controller (RNC).

PDCP uses the services provided by the Radio Link Control (RLC) sublayer.

The main functions of PDCP are:

- compression of redundant Network PDU control information (header compression);
- transfer of packet data protocol user data using services provided by RLC protocol.

---

# 2 References

The following documents contain provisions which, through reference in this text, constitute provisions of the present document.

- References are either specific (identified by date of publication, edition number, version number, etc.) or non-specific.
- For a specific reference, subsequent revisions do not apply.
- For a non-specific reference, the latest version applies. In the case of a reference to a 3GPP document (including a GSM document), a non-specific reference implicitly refers to the latest version of that document *in the same Release as the present document*.

- [1] 3GPP TS 25.401: "UTRAN Overall Description".
- [2] 3GPP TR 21.905: "3G Vocabulary".
- [3] 3GPP TS 25.301: "Radio Interface Protocol Architecture".
- [4] 3GPP TS 25.303: "Interlayer Procedures in Connected Mode".
- [5] 3GPP TS 25.322: "RLC Protocol Specification".
- [6] IETF RFC 2507: "IP Header Compression".
- [7] 3GPP TS 23.060: "General Packet Radio Service (GPRS); Service description; Stage 2".
- [8] IETF RFC 3095: "RObust Header Compression (ROHC): Framework and four profiles: RTP, UDP, ESP, and uncompressed".
- [9] IETF RFC 3096: "Requirements for robust IP/UDP/RTP header compression".

---

# 3 Abbreviations

For the purposes of the present document, the following abbreviations apply:

AS	Access Stratum
CID	Context Identifier
C-SAP	Control Service Access Point
IETF	Internet Engineering Task Force
IP	Internet Protocol
L2	Layer 2 (data link layer)
L3	Layer 3 (network layer)
NAS	Non Access Stratum
PDCP	Packet Data Convergence Protocol

PDU	Protocol Data Unit
PID	Packet Identifier
RB	Radio Bearer
RFC	Request For Comments
RLC	Radio Link Control
ROHC	RObust Header Compression
RTP	Real Time Protocol
SDU	Service Data Unit
TCP	Transmission Control Protocol
UDP	User Datagram Protocol
UE	User Equipment
UMTS	Universal Mobile Telecommunications System
UTRA	UMTS Terrestrial Radio Access
UTRAN	UMTS Terrestrial Radio Access Network

---

## 4 General

### 4.1 Objective

The present document describes the functionality of the UTRAN PDCP. The overall UTRAN logical architecture is defined in [3].

Network layer protocols are intended to be capable of operating over services derived from a wide variety of subnetworks and data links. UMTS supports several network layer protocols providing protocol transparency for the users of the service. At that point of view supported protocols are IPv4 and IPv6. Introduction of new network layer protocols to be transferred over UTRAN shall be possible without any changes to UTRAN protocols. Therefore, all functions related to transfer of packets from higher layers (PDCP SDUs) shall be carried out in a transparent way by the UTRAN network entities. This is one of the requirements for UTRAN PDCP.

Another requirement for the PDCP is to provide functions that help to improve channel efficiency. This requirement is fulfilled by the possibility to implement different kinds of optimisation methods. The currently known methods are standardised IETF header compression protocols.

Every RB is connected to one PDCP entity and one PDCP entity is connected to one RLC entity. The PDCP entities are located in the PDCP sublayer.

Every PDCP entity uses zero, one or several header compression protocol types with certain parameters. Several PDCP entities may use the same protocol type. The protocol types and their parameters are negotiated by higher layers and indicated to PDCP through the PDCP Control Service Access Point (PDCP-C-SAP).

Since the adaptation of different network layer protocols to PDCP is implementation dependent, it is not defined in the present document.

### 4.2 Overview on sublayer architecture

Figure 1 shows the model of the PDCP within the UTRAN protocol architecture. Every PDCP-SAP uses exactly one PDCP entity. Each PDCP entity uses none, one or several header compression protocol types.

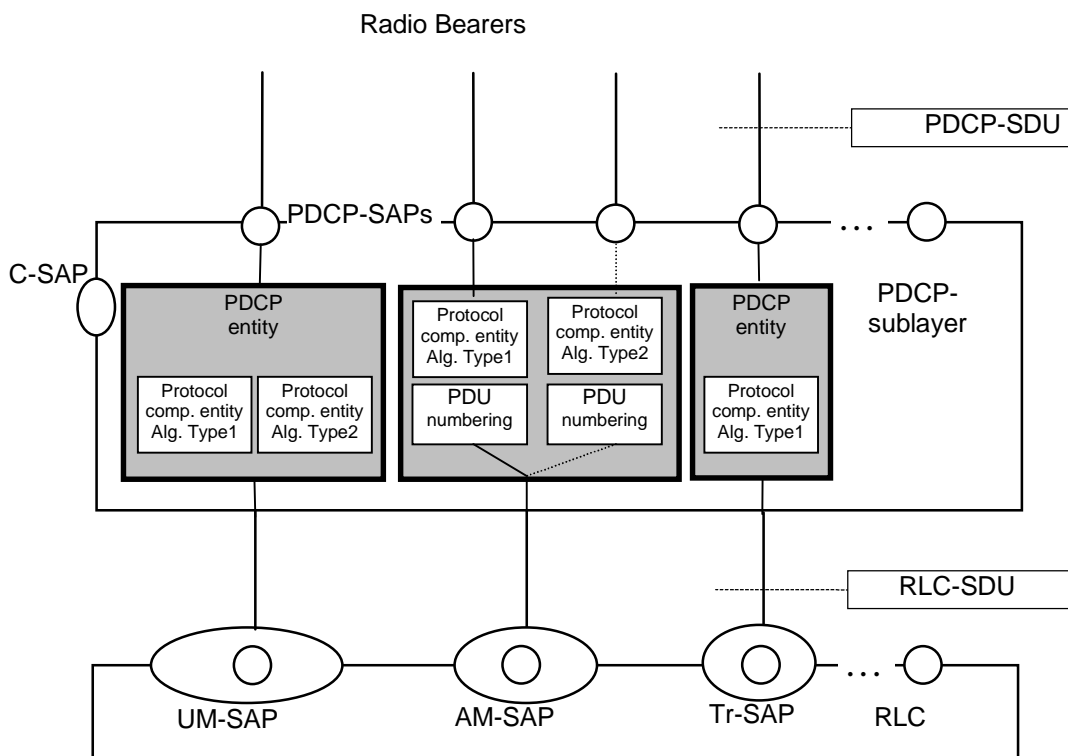

Figure 1: PDCP structure

Figure 1 represents only one possible structure for PDCP and this should not restrict implementation. However, subclause 5.1 shall be adhered to.

## 5 Functions

Packet Data Convergence Protocol shall perform the following functions:

- header compression and decompression of IP data streams (e.g., TCP/IP and RTP/UDP/IP headers) at the transmitting and receiving entity, respectively. The header compression method is specific to the particular network layer, transport layer or upper layer protocol combinations e.g. TCP/IP and RTP/UDP/IP
- transfer of user data. Transmission of user data means that PDCP receives PDCP SDU from the NAS and forwards it to the RLC layer and vice versa
- maintenance of PDCP sequence numbers for radio bearers that are configured to support lossless SRNS relocation

### 5.1 Header Compression

The header compression method is specific for each network layer protocol type. The network layer protocol type is indicated during PDP context activation as defined in [7]. The header compression protocols and their parameters are configured by higher layers for each PDCP entity and indicated to PDCP through the PDCP-C-SAP. Compressor and decompressor initiated signalling between peer PDCP entities, during operation, is carried out in the user plane.

The PDCP layer shall be able to support several header compression protocols and it shall always be possible to extend the list of supported protocols in the future.



The PDCP layer can have one or several PDCP entities. Each PDCP entity may use zero, one, or several header compression protocols. It shall be possible to establish several header compression protocols of different types related to one PDCP entity. Different PDCP entities may include header compression protocols of the same type.

Figure 1 shows an example how PDCP may be configured.

### 5.1.1 Assignment of PID values

PDCP shall be able to distinguish different types of header compression packets to handle them with a correct header compression protocol and furthermore to indicate the type of the packet within a certain protocol. This is realised by utilising the PID field in the PDU structure.

PDCP shall be able to:

- identify different types of header compression protocols
- identify different header compression protocol packet types and
- identify different contexts for a header compression protocol

The requirements above are realised by utilising the PID field in the PDCP PDU format.

The following table illustrates an example of the PID value allocation table when five arbitrary header compression methods (RFC 2507[6], Methods A and B, Method C and RFC 3095 [8]) are configured for one PDCP entity. The table is reconfigured every time the PDCP entity is reconfigured with a change in the supported header compression protocols.

**Table 1: Example of the PID value allocation table**

PID Value	Optimisation method	Packet type
0	No header compression	-
1	RFC 2507	Full header
2	RFC 2507	Compressed TCP
3	RFC 2507	Compressed TCP nondelta
4	RFC 2507	Compressed non TCP
5	RFC 2507	Context state
6	Method A	Uncompressed TCP/IP
7	Method A	Compressed TCP/IP
8	Method B	Uncompressed IP/UDP/RTP
9	Method B	Compressed IP/UDP/RTP
10	RFC 3095	CID 0
11	RFC 3095	CID 1
12	RFC 3095	CID 2
13	Method C	Full header
14	Method C	Compressed header
15...31	Unassigned value	-

The assignment of the PID values follow the general rules listed below:

- PID value 0 is reserved permanently for no compression;
- PID values are assigned in ascending order, starting from 1;
- PID values are assigned independently to each PDCP entity;
- PID values are reassigned for the PDCP entity after renegotiation of the header compression protocols;
- the list of negotiated (or re-negotiated) header compression entities shall be examined, starting from the first one in the list. The number of PID values to be assigned is specified in the subclause for this protocol;
- if there are not enough unused PID values to be assigned to a header compression protocol, the negotiated header compression entities using this protocol shall be ignored without error notification;
- PID values that are used and are not defined invalidate the PDCP PDU;

- for a certain protocol in a PDCP entity the assignment of PID values starts from (n+1) where n is the number of PID values already assigned to other protocols. The assignment is done in the order the protocols are configured by higher layers. In the example given in table 1, RFC 2507 was the first, Method A the second, Method B the third, RFC 3095 the fourth and Method C the fifth protocol configured by higher layers. The PID assignment shall follow this order.

The used header compression protocol, the header compression packet type and header compression protocol contexts are unambiguously known by the basis of the PID value and shall apply to peer PDCP entities. While transferring data, the PID values are conveyed in the field of the PDCP header belonging to the PDCP PDU. Any successfully configured header compression protocol may be used for header compression of a PDCP SDU.

## 5.1.2 IP Header Compression (RFC 2507)

The detailed operation of the "IP Header Compression" protocol is described in clause 3 of the IETF specification RFC 2507 [6]. Furthermore the mechanisms related to error recovery and packet reordering are described in clauses 10 and 11 of the RFC 2507. These mechanisms shall be included in the functionality of the header compression supported by PDCP.

### 5.1.2.1 Context identifiers

Context identifiers for RFC 2507 shall only be included in the RFC 2507 packet types, as defined in [6].

### 5.1.2.2 Assignment of PID values for RFC 2507

The following PID values shall be assigned to the RFC 2507 header compression in the order presented in the table where n is the number of PID values already assigned to other protocols.

**Table 2: PID values assigned to RFC 2507 header compression protocol**

PID value	Optimisation method	Packet type
n+1	RFC 2507	Full header
n+2	RFC 2507	Compressed TCP
n+3	RFC 2507	Compressed TCP non-delta
n+4	RFC 2507	Compressed non-TCP
n+5	RFC 2507	Context state

## 5.1.3 Robust Header Compression (RFC 3095)

The detailed operation of the, "RObust Header Compression (ROHC): Framework and four profiles: RTP, UDP, ESP, and uncompressed", protocol is described in the IETF specification RFC 3095 [8].

### 5.1.3.1 Context identifiers

The context of the RFC 3095 protocol is defined in [8]. RFC 3095 can only be configured to support one or several contexts. Each context is identified by a value known as the context identifier (CID). If CIDs are to be used, then the CID shall be:

- included in the PDCP header; or
- included in the RFC 3095 packet format [8].

The choice of which of the above two methods to use is configured by upper layers. The assignment of the PID values is specified in subclauses 5.1.3.2 and 5.1.3.3, respectively.

### 5.1.3.2 Assignment of PID values for RFC 3095 with CIDs in PDCP PDU Header

The following PID values shall be assigned to the RFC 3095 protocol in the order presented in the table where n is the number of PID values already assigned to other protocols. As shown in the Table 3 below, the allocation of PID values for the RFC 3095 map to the CID values used by RFC 3095. The maximum CID value (CID<sub>x</sub>) is configured by upper layers. The RFC 3095 protocol shall not introduce CIDs in the ROHC packet format.

**Table 3: PID values assigned to RFC 3095 header compression protocol**

PID value	Optimisation method	Packet type
n+1	RFC 3095	CID1
n+2	RFC 3095	CID2
...	RFC 3095	...
...	RFC 3095	...
n+x	RFC 3095	CID <sub>x</sub>

### 5.1.3.3 Assignment of PID values for RFC 3095 packet format

The following PID value shall be assigned to the ROHC header compression as presented in the table where n is the number of PID values already assigned to other protocols.

**Table 4: PID values assigned to RFC 2507 header compression protocol**

PID value	Optimisation method	Packet type
n+1	RFC 3095	RFC 3095 packet format

The RFC 3095 protocol can be configured to handle CIDs within the ROHC packet format. In such a case, PDCP shall not be configured to accommodate ROHC CIDs in the PDCP PID, as described in subclause 5.1.3.1.

### 5.1.3.4 RFC 3095 Segmentation

The RFC 3095 protocol supports segmentation. The segmentation can vary packet by packet and it does not cause any overhead to packets that are not segmented. The segmentation in RFC 3095 shall not be used when RFC 3095 uses the non-transparent mode of RLC [5], in which case the MRRU (maximum reconstructed reception unit) shall be equal to 0. RFC 3095 segmentation shall only be used when RFC 3095 uses the transparent mode of RLC and the PACKET\_SIZES\_ALLOWED is used to configure ROHC packet sizes. Furthermore, segmentation shall be applied if the produced packet does not fit to the largest packet as indicated by PACKET\_SIZES\_ALLOWED.

### 5.1.3.5 Protocol Parameters

RFC 3095 has two types of parameters [8]:

- configuration parameters: these are mandatory and must be configured between compressor and decompressor peers.
- implementation parameters: these are optional and, when used, stipulate how RFC 3095 operates.

These parameters are categorized in four different groups, as defined below:

- M: Mandatory and configured by upper layers.
- MO: Parameters that must be supported and when used can only be configured or triggered by upper layers.
- O: Optional RFC 3095 parameters that are not configured by upper layers. They may be used locally (i.e. UTRAN and/or in UE) for RFC 3095.
- N/A: These are not used in RFC 3095.

The usage and definition of the parameters shall be as specified below.

- MAX\_CID (M): This is the maximum CID value that can be used. One CID value shall always be reserved for uncompressed flows.
- LARGE\_CIDS: This is not configured by upper layers but inferred from the configured value of MAX\_CID according to the following rule:

If MAX\_CID > 15 then LARGE\_CIDS = TRUE else LARGE\_CIDS = FALSE.

- PROFILES (M): Profiles are used to define which profiles are allowed to be used by the UE in uplink. All profiles defined in [8] shall be supported by the UE.
- FEEDBACK\_FOR (N/A):
- MRRU (M): Segmentation is not used by default.
- NO\_OF\_PACKET\_SIZES\_ALLOWED (O)
- PACKET\_SIZES\_ALLOWED (MO): This parameter, if configured, governs which packet sizes in bytes may be used by RFC 3095. Thus, packet sizes not in the set of values for this parameter shall not be used.
- PAYLOAD\_SIZES (O)
- NO\_OF\_PACKET\_SIZES\_USED (O)
- PACKET\_SIZES\_USED (O)
- CONTEXT\_REINITIALIZATION (MO)
- MODE (O)
- CLOCK\_RESOLUTION (O)
- REVERSE\_DECOMPRESSION\_DEPTH (M): Default value is that reverse decompression is not used.

## 5.2 Void

## 5.3 Data Transfer

### 5.3.1 Data transfer over acknowledged mode RLC

If header compression is negotiated the PDCP entity shall perform header compression upon reception of a PDCP-DATA.Req. The PDCP-PDU is then delivered in RLC-AM-DATA.Req to RLC.

During operation, when the peer PDCP entity receives the PDCP-PDU in a RLC-AM-DATA.Ind primitive, the PDCP entity shall perform the header decompression (if negotiated) of PDCP-PDU to obtain the PDCP SDU and deliver the PDCP SDU to the PDCP user with the PDCP-DATA.Ind. The following figure illustrates data transfer over acknowledged mode RLC.

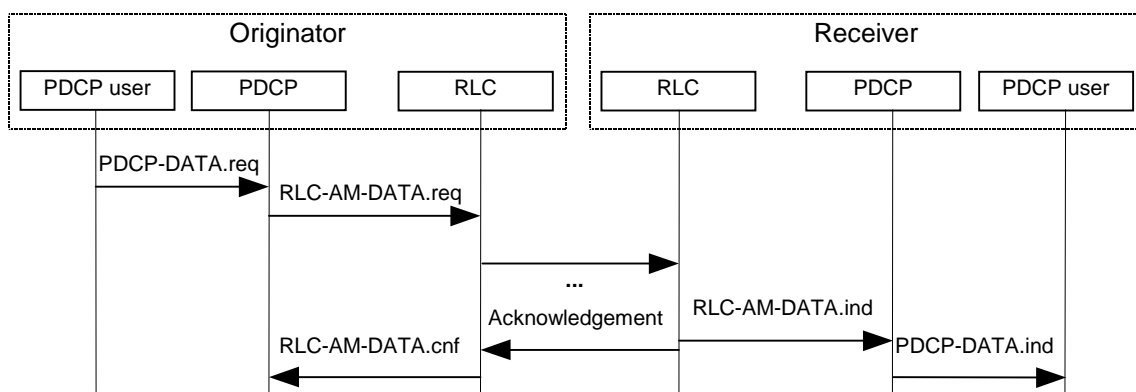

**Figure 2: PDCP data transfer over acknowledged mode RLC**

### 5.3.2 Data transfer over unacknowledged and transparent mode RLC

If header compression is negotiated the PDCP entity shall perform header compression upon reception of a PDCP-DATA.Req. The PDCP-PDU is then delivered in RLC-UM-DATA.Req or RLC-Tr-DATA.Req to RLC.

When the peer PDCP entity receives the PDCP-PDU in the RLC-UM-DATA.Ind or RLC-Tr-DATA.Ind primitive, the PDCP entity shall perform the header decompression (if negotiated) of PDCP-PDU to obtain the PDCP SDU and deliver the PDCP SDU to the PDCP user with the PDCP-DATA.Ind. The following figure illustrates data transfer over unacknowledged and transparent mode RLC.

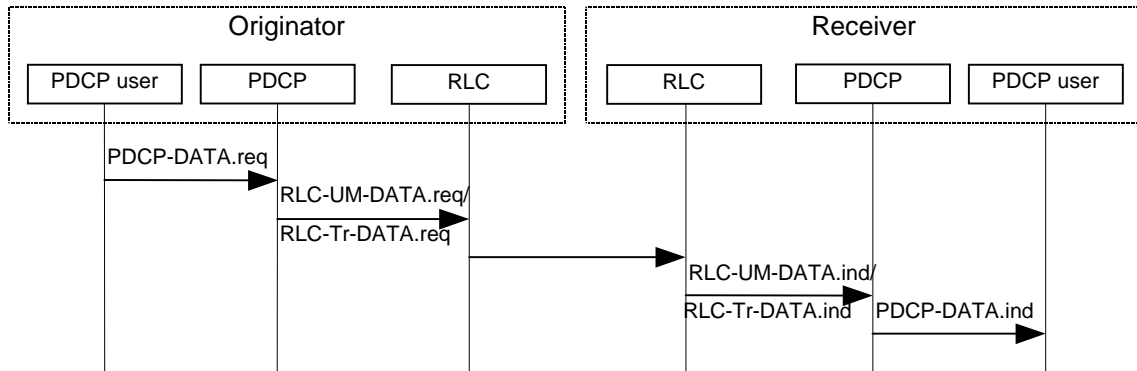

Figure 3: PDCP data transfer over unacknowledged or transparent mode RLC

## 5.4 SRNS Relocation

Lossless SRNS relocation is only applicable when RLC is in in-sequence delivery and acknowledged mode PDCP will only support lossless SRNS relocation if it is 'capable' of doing so. This is indicated by higher layers.

The PDCP layer shall, for those radio bearers that are configured to support lossless SRNS relocation:

- support PDCP sequence numbering as specified in subclause 5.4.1.

The PDCP layer shall carry out the following during lossless SRNS relocation:

- provide unconfirmed PDCP SDUs and sequence numbers for forwarding to the target RNC

For each radio bearer, the Receive PDCP Sequence Number of the next PDCP SDU expected to be received is transferred from the source to target SRNC. For each radio bearer the source SRNC forwards to the target SRNC the downlink PDCP-SDUs. Source SRNC provides the Send PDCP sequence number of the first PDCP SDU to be forwarded to the target SRNC.

The target SRNC shall send to the UE the next expected UL Receive PDCP Sequence Number. The UE shall send to the target SRNC the DL Receive PDCP Sequence Number of the next expected PDCP SDU. The successfully transmitted PDCP SDUs are thus confirmed. More detailed descriptions of this procedure can be found in [4] and [7].

The reset of all compression entities, for an RB, shall be made during SRNS relocation. Header compression is still possible during relocation. Negotiated compression parameters remain valid during reset, but all state information is initialised, e.g. header compression contexts. Therefore, in header compression case, the first 'compressed' packet is a full header. For later releases of this specification, it may be considered not to reset the PDCP entity, internal protocol information, i.e. states and header compression contexts, but to forward these from the source SRNC to target SRNC. Header compression for a PDCP entity can then continue from the state that it had directly before SRNS relocation.

### 5.4.1 PDCP Sequence Numbering

PDCP sequence numbering is only applicable when lossless SRNS relocation is to be supported. The value of the PDCP sequence number ranges from 0 to 65535. The PDCP SN window size indicates the maximum number of PDCP PDUs that can be numbered at any given time. The PDCP SN window size is negotiated by higher layers. When the PDCP entity is setup for the first time for the PDCP user the PDCP sequence numbers are initialised to zero.

For each radio bearer:

- a UL\_Send PDCP sequence number is associated with each sent PDCP-PDU in the UE and is incremented by one when a PDCP PDU is delivered to RLC;
- a DL\_Send PDCP sequence number is associated with each sent PDCP-PDU in UTRAN and is incremented by one when a PDCP PDU is delivered to RLC;
- a UL\_Receive PDCP sequence number is associated with each received PDCP-PDU in UTRAN and is incremented by one when a PDCP PDU is received from RLC or is incremented by one for each discarded RLC SDU, as indicated by the RLC SDU Discard function [5];
- a DL\_Receive PDCP sequence number is associated with each received PDCP-PDU in the UE and is incremented by one when a PDCP PDU is received from RLC or is incremented by one for each discarded RLC SDU, as indicated by the RLC SDU Discard function [5].

PDCP sequence numbers are never decremented in the PDCP Tx.

PDCP SeqNum PDUs shall be sent by the peer PDCP entities when synchronization of the PDCP SN is required. It shall only be used for radio bearers that support or are configured / reconfigured to support lossless SRNS relocation. Synchronization of PDCP SN is required after RLC reset, RB reconfiguration or reception of invalid next expected UL/DL Receive PDCP Sequence Number after relocation.

When a PDCP entity receives a PDCP SeqNum PDU, the receive PDCP sequence number shall be set to the value indicated in the PDCP SeqNum PDU.

PDCP SeqNum PDUs shall not be delivered to RLC after RLC has confirmed the successful transmission of a RLC SDU that contained a numbered PDCP PDU.

---

## 6 Services

### 6.1 Services provided to upper layers

The following services are provided by PDCP to upper layers:

- PDCP SDU delivery.

### 6.2 Services expected from RLC layer

For a detailed description of the following functions see [5].

- Data transfer in acknowledged mode.
- Data transfer in unacknowledged mode.
- Data transfer in transparent mode.
- Segmentation and reassembly.
- In-Sequence delivery.

---

## 7 Elements for layer-to-layer communication

The interaction between the PDCP layer and other layers are described in terms of primitives where the primitives represent the logical exchange of information and control between the PDCP layer and other layers. The primitives shall not specify or constrain implementations.

### 7.1 Primitives between PDCP and upper layers

The primitives between PDCP and upper layers are shown in table 5.

**Table 5: Primitives between PDCP and upper layers**

Generic Name	Parameter			
	Req. Data	Ind. Data	Resp. Not Defined	Conf. Not Defined
PDCP-DATA			Not Defined	Not Defined
CPDCP-CONFIG	PDCP-Info, RLC-SAP SN_Sync	Not Defined	Not Defined	Not Defined
CPDCP-RELEASE	RLC-SAP	Not Defined	Not Defined	Not Defined
CPDCP-SN	PDCP SN	Not Defined	Not Defined	Not Defined
CPDCP-RELOC	Receive_SN	Not Defined	Not Defined	Receive_SN, Send_SN

Each Primitive is defined as follows:

- a) PDCP-DATA-Req./Ind.
  - PDCP-DATA-Req is used by higher user-plane protocol layers to request a transmission of higher layer PDU. PDCP-DATA-Ind is used to deliver PDCP SDU that has been received to upper user plane protocol layers.
- b) CPDCP-CONFIG-Req.
  - CPDCP-CONFIG Req is used to configure and – in case of already existing PDCP entity – to reconfigure a PDCP entity and to assign it to the radio bearer associated with that entity.
- c) PDCP-RELEASE-Req.
  - CPDCP-RELEASE-Req is used by higher layers to release a PDCP entity.
- d) PDCP-SN-Req.
  - CPDCP-SN-Req is used to transfer the PDCP SN to PDCP.
- e) CPDCP- RELOC-Req.
  - CPDCP-RELOC-Req initiates the SRNS relocation procedure in PDCP for those radio bearers that are configured to support lossless SRNS relocation. The Receive\_SN is only included when the UE receives a new U-RNTI.

The following parameters are used in the primitives:

- 1) PDCP info:
  - contains the parameters for each of the header compression protocols configured to be used by one PDCP entity.
- 2) RLC-SAP:
  - the RLC-SAP (Tr/UM/AM) used by PDCP entity when communicating with RLC sublayer.
- 3) SN\_Sync:
  - Indicates that PDCP should start PDCP sequence number synchronization
- 4) Send\_SN:
  - The send PDCP sequence number. There is one in the uplink and one in the downlink. Refer to subclause 5.4.1.
- 5) Receive\_SN:
  - The receive PDCP sequence number. There is one in the uplink and one in the downlink. Refer to subclause 5.4.1.
- 6) PDCP SN:

- This includes a PDCP sequence number.

## 8 Elements for peer-to-peer communication

### 8.1 Protocol data units

Different protocol data unit formats are defined in PDCP, one not introducing any overhead to the (compressed) PDCP SDU, others introducing such overhead. Whether overhead is introduced by the PDCP protocol is configured for the PDCP entity by higher layers.

### 8.2 Formats

A PDCP PDU is byte-aligned, if the RLC is run on unacknowledged or acknowledged mode. Otherwise, in transparent mode, it is bit-aligned. In the drawings in subclause 8.2, bit strings are represented by tables in which the first bit is the leftmost one on the first line of the table, the last bit is the rightmost on the last line of the table, and more generally the bit string is to be read from left to right and then in the reading order of the lines.

SDUs are bit strings, with any non-null length. If not compressed within PDCP an SDU is included from first bit onward.

#### 8.2.1 PDCP-No-Header PDU

The PDCP-No-Header PDU does not introduce any overhead to the PDCP SDU.

The format of the PDCP-No-Header-PDU is shown in table 6.

**Table 6: PDCP-No-Header PDU**

Data
------

#### 8.2.2 PDCP Data PDU

The data PDU is used to convey a payload unit containing a PDCP SDU, header compression related control signalling or data that has been obtained from PDCP SDU after header compression.

The format of the PDCP-Data-PDU is shown in table 7.

**Table 7: PDCP-Data-PDU format**

PDU type	PID
Data	

#### 8.2.3 PDCP SeqNum PDU

The sequence number PDU is used to convey a payload unit containing a PDCP PDU sequence number and PDCP SDU, header compression related control signalling or data that has been obtained from PDCP SDU after header compression.

The format of the PDCP-SeqNum-PDU is shown in table 8.



**Table 8: PDCP-SeqNum-PDU format**

PDU type	PID
Sequence number	
Data	

## 8.3 Parameters

If not otherwise mentioned in the definition of each field then the bits in the parameters shall be interpreted as follows: the left most bit string is the first and most significant and the right most bit is the last and least significant bit.

Unless otherwise mentioned, integers are encoded in standard binary encoding for unsigned integers. In all cases the bits appear ordered from MSB to LSB when read in the PDU.

### 8.3.1 PDU Type

Length: 3 bits.

The PDU type field indicates the PDCP-data-PDU type.

Bit	PDU Type
<b>000</b>	PID field used for header compression information (PDCP-PDU format described in table 5)
<b>001</b>	PID field used for header compression information and the PDCP PDU sequence number included (PDCP-PDU format described in table 6)
<b>010-111</b>	Reserved (PDUs with this encoding are invalid for this version of the protocol)

### 8.3.2 PID

Length: 5 bits.

The PID field indicates the used header compression packet type or a context identifier.

Bit	Description
<b>00000</b>	No header compression
<b>00001-11111</b>	Dynamically negotiated header compression identifier, as described in subclause 5.1.1

The PID field value defines the used header compression type and packet type. One compression protocol may reserve a certain amount of values from the PID field value space for different packet types. The receiving PDCP entity makes the reverse operation (i.e. header decompression) according to the PID field value. There is no fixed relationship between the PID field value and the used optimisation / packet type, but PID field values are defined dynamically at the PDCP parameter negotiation.

The PID field can also be used to represent context identifier values, as illustrated in subclause 5.1.1.

### 8.3.3 Data

PDCP SDUs that have been header compressed are mapped to this field if header compression is negotiated. Otherwise, PDCP SDUs are mapped to this field.

### 8.3.4 Sequence number

Length: 16 bits

PDCP PDU sequence number.

---

## 9 Handling of unknown, unforeseen and erroneous protocol data

In case of error situations the following action is foreseen:

- 1) PDCP entity should discard invalid PDU.

## Annex A (informative): Change history

Change history							
Date	TSG #	TSG Doc.	CR	Rev	Subject/Comment	Old	New
12/1999	RP-06	RP-99645	-		Approved at TSG-RAN #6 and placed under Change Control	-	3.0.0
03/2000	RP-07	RP-000041	004		Bit order of PDCP PDUs	3.0.0	3.1.0
	RP-07	RP-000041	005		Changes to PDCP	3.0.0	3.1.0
06/2000	RP-08	RP-000221	006	4	Changes in PDCP PDU format due to PDCP sequence numbering	3.1.0	3.2.0
09/2000	RP-09	RP-000359	009	3	Clarification of PDCP Sequence Numbering	3.1.0	3.2.0
	RP-09	RP-000359	011		Clarification on how to handle invalid PDUs	3.2.0	3.3.0
	RP-09	RP-000359	012	2	Primitives required for SRNS relocation	3.2.0	3.3.0
	RP-09	RP-000359	015		Handling of invalid PDCP PDU sequence number	3.2.0	3.3.0
03/2001	RP-11	RP-010027	018	1	Editorial Corrections	3.3.0	3.4.0
	RP-11	RP-010027	019	1	Updates necessary for Rel-4 specification	3.3.0	3.4.0
	RP-11	RP-010039	017	2	Robust Header Compression	3.4.0	4.0.0

---

## History

<b>Document history</b>		
V4.0.0	March 2001	Publication