

ETSI TS 125 224 V3.3.0 (2000-06)

Technical Specification

Universal Mobile Telecommunications System (UMTS); Physical Layer Procedures (TDD) (3G TS 25.224 version 3.3.0 Release 1999)



Reference

RTS/TSGR-0125224UR2

Keywords

UMTS

ETSI

650 Route des Lucioles
F-06921 Sophia Antipolis Cedex - FRANCE

Tel.: +33 4 92 94 42 00 Fax: +33 4 93 65 47 16

Siret N° 348 623 562 00017 - NAF 742 C
Association à but non lucratif enregistrée à la
Sous-Préfecture de Grasse (06) N° 7803/88

Important notice

Individual copies of the present document can be downloaded from:

<http://www.etsi.org>

The present document may be made available in more than one electronic version or in print. In any case of existing or perceived difference in contents between such versions, the reference version is the Portable Document Format (PDF).

In case of dispute, the reference shall be the printing on ETSI printers of the PDF version kept on a specific network drive within ETSI Secretariat.

Users of the present document should be aware that the document may be subject to revision or change of status.

Information on the current status of this and other ETSI documents is available at <http://www.etsi.org/tb/status/>

If you find errors in the present document, send your comment to:
editor@etsi.fr

Copyright Notification

No part may be reproduced except as authorized by written permission.
The copyright and the foregoing restriction extend to reproduction in all media.

© European Telecommunications Standards Institute 2000.

All rights reserved.

Intellectual Property Rights

IPRs essential or potentially essential to the present document may have been declared to ETSI. The information pertaining to these essential IPRs, if any, is publicly available for **ETSI members and non-members**, and can be found in ETSI SR 000 314: *"Intellectual Property Rights (IPRs); Essential, or potentially Essential, IPRs notified to ETSI in respect of ETSI standards"*, which is available from the ETSI Secretariat. Latest updates are available on the ETSI Web server (<http://www.etsi.org/ipr>).

Pursuant to the ETSI IPR Policy, no investigation, including IPR searches, has been carried out by ETSI. No guarantee can be given as to the existence of other IPRs not referenced in ETSI SR 000 314 (or the updates on the ETSI Web server) which are, or may be, or may become, essential to the present document.

Foreword

This Technical Specification (TS) has been produced by the ETSI 3rd Generation Partnership Project (3GPP).

The present document may refer to technical specifications or reports using their 3GPP identities, UMTS identities or GSM identities. These should be interpreted as being references to the corresponding ETSI deliverables.

The cross reference between GSM, UMTS, 3GPP and ETSI identities can be found under www.etsi.org/key .

Contents

Foreword	4
1 Scope.....	5
2 References.....	5
3 Abbreviations.....	5
4 Physical layer procedures (TDD).....	6
4.1 General.....	6
4.2 Transmitter Power Control	6
4.2.1 General Parameters	6
4.2.2 Uplink Control	6
4.2.2.1 General Limits	6
4.2.2.2 PRACH.....	7
4.2.2.3 DPCH, PUSCH.....	7
4.2.2.3.1 Out of synchronisation handling	7
4.2.3 Downlink Control.....	7
4.2.3.1 P-CCPCH, PICH	7
4.2.3.2 S-CCPCH	8
4.2.3.3 Dedicated Physical Channel, PDSCH	8
4.2.3.3.1 Out of synchronisation handling	8
4.3 Timing Advance	8
4.3.1 Timing advance with UL Synchronization.....	8
4.4 Synchronisation and Cell Search Procedures.....	9
4.4.1 Cell Search	9
4.4.2 Dedicated channel synchronisation	9
4.4.2.1 Synchronisation primitives	9
4.4.2.1.1 General.....	9
4.4.2.1.2 Downlink synchronisation primitives	10
4.4.2.1.3 Uplink synchronisation primitives	10
4.4.2.2 Radio link monitoring.....	10
4.4.2.2.1 Downlink radio link failure.....	10
4.4.2.2.2 Uplink radio link failure/restore.....	10
4.5 Discontinuous transmission (DTX) of Radio Frames	11
4.6 Downlink Transmit Diversity	11
4.6.1 Transmit Diversity for DPCH	11
4.6.2 Transmit Diversity for SCH.....	11
4.6.2.1 SCH Transmission Scheme	12
4.6.3 Transmit Diversity for P-CCPCH	12
4.6.3.1 P-CCPCH Transmission Scheme	12
4.7 Random access procedure.....	13
4.7.1 Physical random access procedure	13
4.8 DSCH procedure.....	15
4.8.1 DSCH procedure with TFCI indication.....	15
4.8.2 DSCH procedure with midamble indication	15
Annex A (informative): Power Control.....	16
A.1 An Example for Calculating α	16
A.2 Example Implementation of Downlink Power Control in the UE	16
Annex B (informative): Determination of Weight Information	17
B.1 STD Weights	17
B.2 TxAA Weights.....	17
Annex C (informative): Change history	18

Foreword

This Technical Specification (TS) has been produced by the 3rd Generation Partnership Project (3GPP).

The contents of the present document are subject to continuing work within the TSG and may change following formal TSG approval. Should the TSG modify the contents of the present document, it will be re-released by the TSG with an identifying change of release date and an increase in version number as follows:

Version x.y.z

where:

- x the first digit:
 - 1 presented to TSG for information;
 - 2 presented to TSG for approval;
 - 3 or greater indicates TSG approved document under change control.
- y the second digit is incremented for all changes of substance, i.e. technical enhancements, corrections, updates, etc.
- z the third digit is incremented when editorial only changes have been incorporated in the document.

1 Scope

The present document describes the Physical Layer Procedures in the TDD mode of UTRA.

2 References

The following documents contain provisions which, through reference in this text, constitute provisions of the present document.

- References are either specific (identified by date of publication, edition number, version number, etc.) or non-specific.
- For a specific reference, subsequent revisions do not apply.
- For a non-specific reference, the latest version applies.

- [1] 3G TS 25.201: "Physical layer - general description".
- [2] 3G TS 25.102: "UE physical layer capabilities".
- [3] 3G TS 25.211: "Physical channels and mapping of transport channels onto physical channels (FDD)".
- [4] 3G TS 25.212: "Multiplexing and channel coding (FDD)".
- [5] 3G TS 25.213: "Spreading and modulation (FDD)".
- [6] 3G TS 25.214: "Physical layer procedures (FDD)".
- [7] 3G TS 25.215: "Physical Layer - Measurements (FDD)".
- [8] 3G TS 25.221: "Physical channels and mapping of transport channels onto physical channels (TDD)".
- [9] 3G TS 25.222: "Multiplexing and channel coding (TDD)".
- [10] 3G TS 25.223: "Spreading and modulation (TDD)".
- [11] 3G TS 25.225: "Physical Layer - Measurements (TDD)".
- [12] 3G TS 25.301: "Radio Interface Protocol Architecture".
- [13] 3G TS 25.302: "Services Provided by the Physical Layer".
- [14] 3G TS 25.401: "UTRAN Overall Description".
- [15] 3G TS 25.331: "RRC Protocol Specification"

3 Abbreviations

For the purposes of the present document, the following abbreviations apply:

BCCH	Broadcast Control Channel
BCH	Broadcast Channel
CCTrCH	Coded Composite Transport Channel
DCA	Dynamic Channel Allocation
DPCH	Dedicated Physical Channel
DTX	Discontinuous Transmission
FACH	Forward Access Channel
NRT	Non-Real Time

ODMA	Opportunity Division Multiple Access
ORACH	ODMA Random Access Channel
P-CCPCH	Primary Common Control Physical Channel
PRACH	Physical Random Access Channel
RACH	Random Access Channel
RT	Real Time
RU	Resource Unit
S-CCPCH	Secondary Common Control Physical Channel
SCH	Synchronisation Channel
SFN	System Frame Number
SSCH	Secondary Synchronisation Channel
STD	Selective Transmit Diversity
TA	Timing Advance
TPC	Transmit Power Control
TSTD	Time Switched Transmit Diversity
TxAA	Transmit Adaptive Antennas
UE	User Equipment
VBR	Variable Bit Rate

4 Physical layer procedures (TDD)

4.1 General

4.2 Transmitter Power Control

4.2.1 General Parameters

Power control is applied for the TDD mode to limit the interference level within the system thus reducing the intercell interference level and to reduce the power consumption in the UE.

All codes within one timeslot allocated to the same CCTrCH use the same transmission power, in case they have the same spreading factor.

Table 1: Transmit Power Control characteristics

	Uplink	Downlink
Power control rate	Variable 1-7 slots delay (2 slot SCH) 1-14 slots delay (1 slot SCH)	Variable, with rate depending on the slot allocation.
Step size		1, 2, 3 dB
Remarks	All figures are without processing and measurement times	Within one timeslot the powers of all active codes may be balanced to within a range of 20 dB

4.2.2 Uplink Control

4.2.2.1 General Limits

By means of higher layer signalling, the Maximum_Allowed_UL_TX_ power for uplink may be set to a value lower than what the terminal power class is capable of. The total transmit power shall not exceed the allowed maximum. If this would be the case, then the transmit power of all uplink physical channels in a timeslot is reduced by the same amount in dB.

4.2.2.2 PRACH

The transmit power for the PRACH is set by higher layers based on open loop power control as described in TS 25.331.

4.2.2.3 DPCH, PUSCH

After the synchronisation between UTRAN and UE is established, the UE transits into open-loop transmitter power control (TPC).

The transmitter power of UE shall be calculated by the following equation:

$$P_{UE} = \alpha L_{P-CCPCH} + (1-\alpha)L_0 + I_{BTS} + SIR_{TARGET} + \text{Constant value}$$

where

P_{UE} : Transmitter power level in dBm.

$L_{P-CCPCH}$: Measure representing path loss in dB (reference transmit power is broadcast on BCH).

L_0 : Long term average of path loss in dB.

I_{BTS} : Interference signal power level at cell's receiver in dBm, which is broadcast on BCH.

α : α is a weighting parameter which represents the quality of path loss measurements. α may be a function of the time delay between the uplink time slot and the most recent down link time slot containing a physical channel that provides the beacon function, see [8]. α is calculated at the UE. An example for calculating α as a function of the time delay is given in annex A.1.

SIR_{TARGET} : Target SNR in dB. A higher layer outer loop adjusts the target SIR.

Constant value: This value shall be set by higher Layer (operator matter). and is broadcast on BCH.

If the midamble is used in the evaluation of $L_{P-CCPCH}$ and L_0 , and the Tx diversity scheme used for the P-CCPCH involves the transmission of different midambles from the diversity antennas, the received power of the different midambles from the different antennas shall be combined prior to evaluation of these variables.

4.2.2.3.1 Out of synchronisation handling

UE shall shut off the uplink transmission if the following criteria is fulfilled:

- the UE estimates the received dedicated channel burst quality over the last [160] ms period to be worse than a threshold Q_{out} . This criterion is never fulfilled during the first [160] ms of the dedicated channel's existence. Q_{out} is defined implicitly by the relevant tests in TS 25.102;
- if the UE detect the beacon channel reception level [10 dBm] above the handover triggering level, then the UE uses [320] ms estimation period for the burst quality evaluation.

UE shall resume the uplink transmission if the following criteria is fulfilled:

- the UE estimates the burst reception quality over the last [160] ms period to be better than a threshold Q_{in} . This criterion is always fulfilled during the first [160] ms of the dedicated channel's existence. Q_{in} is defined implicitly by the relevant tests in TS 25.102.

4.2.3 Downlink Control

4.2.3.1 P-CCPCH, PICH

The Primary CCPCH transmit power is set by higher layer signalling and can be changed based on network determination on a slow basis. The reference transmit power of the P-CCPCH is signalled on the BCH. The PICH is transmitted with the same power as the P-CCPCH.

4.2.3.2 S-CCPCH

The relative transmit power of the Secondary CCPCH compared to the P-CCPCH transmit power is set by higher layer signalling.

4.2.3.3 Dedicated Physical Channel, PDSCH

The initial transmission power of the downlink Dedicated Physical Channel and the PDSCH is set by the network. After the initial transmission, the UTRAN transits into SIR-based inner loop power control.

The UE shall generate TPC commands to control the network transmit power and send them in the TPC field of the uplink DPCH and PUSCH. An example on how to derive the TPC commands is given in Annex A.2

As a response to the received TPC command, UTRAN may adjust the transmit power of all downlink DPCHs and PDSCHs of this radio link. When the TPC command is judged as "down", the transmission power may be reduced by one step, whereas if judged as "up", the transmission power may be raised by one step. The UTRAN may apply an individual offset to the transmission power in each timeslot according to the downlink interference level at the UE. The transmission power of one DPCH or PDSCH shall not exceed the limits set by higher layer signalling by means of Maximum_DL_Power (dB) and Minimum_DL_Power (dB). The transmission power is defined as the average power of the complex QPSK symbols of a single DPCH before spreading.

During a downlink transmission pause, the UTRAN may accumulate the TPC commands received. The initial UTRAN transmission power for the first data transmission after the pause may then be set to the sum of transmission power before the pause and a power offset according to the accumulated TPC commands. Additionally this sum may include a constant set by the operator and a correction term due to uncertainties in the reception of the TPC bits.

The total downlink transmission power at the nodeB within one timeslot shall not exceed Maximum Transmission Power set by higher layer signalling. In case the total power of the sum of all transmissions would exceed this limit, then the transmission power of all downlink DPCHs is reduced by the amount that allows fulfilling the requirement. The same amount of power reduction is applied to all DPCHs.

A higher layer outer loop adjusts the target SIR.

4.2.3.3.1 Out of synchronisation handling

When the dedicated physical channel out of sync criteria based on the received burst quality is as given in the subclause 4.4.2 then the UE shall set the uplink TPC command = "up". The CRC based criteria shall not be taken into account in TPC bit value setting.

4.3 Timing Advance

UTRAN may adjust the UE transmission timing with timing advance. The initial value for timing advance will be determined in the UTRAN by measurement of the timing of the PRACH. The required timing advance will be represented as an 6 bit number (0-63) being the multiple of 4 chips which is nearest to the required timing advance.

When Timing Advance is used the UTRAN will continuously measure the timing of a transmission from the UE and send the necessary timing advance value. On receipt of this value the UE shall adjust the timing of its transmissions accordingly in steps of ± 4 chips. The transmission of TA values is done by means of higher layer messages. Upon receiving the TA command the UE shall adjust its transmission timing according to the timing advance command at the beginning of the next frame that fulfils the SFN Mod 20 = 0 criteria and which does not occur sooner than 10 frames after the TTI period for the DCCH carrying the timing advance command ended.

When TDD to TDD handover takes place the UE shall transmit in the new cell with timing advance TA adjusted by the relative timing difference Δt between the new and the old cell:

$$TA_{\text{new}} = TA_{\text{old}} + 2\Delta t$$

4.3.1 Timing advance with UL Synchronization

If UL Synchronization is used, the timing advance is sub-chip granular and with high accuracy in order to enable synchronous CDMA in the UL. The required timing advance will be represented as a multiple of 1/4 chips.

The UTRAN will continuously measure the timing of a transmission from the UE and send the necessary timing advance value. On receipt of this value the UE will adjust the timing of its transmissions accordingly in steps of $\pm 1/4$ chips.

Support of UL synchronisation is optional for the UE.

4.4 Synchronisation and Cell Search Procedures

4.4.1 Cell Search

During the initial cell search, the UE searches for a cell. It then determines the midamble, the downlink scrambling code and frame synchronisation of that cell. The initial cell search uses the Synchronisation Channel (SCH) described in [8]. The generation of synchronisation codes is described in [10].

This initial cell search is carried out in three steps:

Step 1: Slot synchronisation

During the first step of the initial cell search procedure the UE uses the primary synchronisation code c_p to acquire slot synchronisation to the strongest cell. Furthermore, frame synchronisation with the uncertainty of 1 out of 2 is obtained in this step. A single matched filter (or any similar device) is used for this purpose, that is matched to the primary synchronisation code which is common to all cells.

Step 2: Frame synchronisation and code-group identification

During the second step of the initial cell search procedure, the UE uses the modulated Secondary Synchronisation Codes to find frame synchronisation and identify one out of 32 code groups. Each code group is linked to a specific t_{Offset} , thus to a specific frame timing, and is containing 4 specific scrambling codes. Each scrambling code is associated with a specific short and long basic midamble code.

In Case 2 it is required to detect the position of the next synchronization slots. To detect the position of the next synchronization slots, the primary synchronization code is correlated with the received signal at offsets of 7 and 8 time slots from the position of the primary code that was detected in Step 1.

Then, the received signal at the positions of the synchronization codes is correlated with the primary synchronization Code C_p and the secondary synchronization codes $\{C_0, \dots, C_{15}\}$. Note that the correlations can be performed coherently over M time slots, where at each slot a phase correction is provided by the correlation with the primary code. The minimal number of time slots is $M=1$, and the performance improves with increasing M .

Step 3: Scrambling code identification

During the third and last step of the initial cell-search procedure, the UE determines the exact basic midamble code and the accompanying scrambling code used by the found cell. They are identified through correlation over the P-CCPCH with all four midambles of the code group identified in the second step. Thus the third step is a one out of four decision. This step is taking into account that the P-CCPCH containing the BCH is transmitted using the first channelization code ($c_{Q=16}^{(h=1)}$ in [10]) and using the first midamble $\mathbf{m}^{(1)}$ (derived from basic midamble code \mathbf{m}_p in [8]).

Thus P-CCPCH code and midamble can be immediately derived when knowing scrambling code and basic midamble code.

NOTE: The cell parameters change from frame to frame, cf. "Table 7 Alignment of cell parameter cycling and SFN" in [10].

4.4.2 Dedicated channel synchronisation

4.4.2.1 Synchronisation primitives

4.4.2.1.1 General

For the dedicated channels, synchronisation primitives are used to indicate the synchronisation status of radio links, both in uplink and downlink. The definition of the primitives is given in the following subclauses.

4.4.2.1.2 Downlink synchronisation primitives

Layer 1 in the UE shall every radio frame check synchronisation status of the downlink dedicated channels. Synchronisation status is indicated to higher layers, using the CPHY-Sync-IND or CPHY-Out-of-Sync-IND primitives.

Out-of-sync shall be reported using the CPHY-Out-of-Sync-IND primitive if either of the following criteria is fulfilled:

- the UE estimates the received dedicated channel burst quality over the last [160] ms period to be worse than a threshold Q_{out} . This criterion is never fulfilled during the first [160] ms of the dedicated channel's existence. Q_{out} is defined implicitly by the relevant tests in TS 25.102;
- if the UE detect the beacon channel reception level [10 dBm] above the handover triggering level, the UE uses [320] ms estimation period for the burst quality evaluation;
- the last [16] transport blocks, as observed on all TrCHs using CRC, are received with incorrect CRC. In addition, over the last [160] ms, no transport block has been received with correct CRC. In case the beacon channel reception criteria is fulfilled the values are [32] transport blocks and [320] ms respectively.

In-sync shall be reported using the CPHY-Sync-IND primitive if both of the following criteria are fulfilled:

- the UE estimates the burst reception quality over the last [160] ms period to be better than a threshold Q_{in} . This criterion is always fulfilled during the first [160] ms of the dedicated channel's existence. Q_{in} is defined implicitly by the relevant tests in TS 25.104;
- at least one transport block, as observed on all TrCHs using CRC, is received with correct CRC. If there is no TrCH using CRC, this criterion is always fulfilled.

How the primitives are used by higher layers is described in TS 25.331.

4.4.2.1.3 Uplink synchronisation primitives

Layer 1 in the Node B shall every radio frame check synchronisation status of the radio link. Synchronisation status is indicated to the RL Failure/Restored triggering function using either the CPHY-Sync-IND or CPHY-Out-of-Sync-IND primitive.

The exact criteria for indicating in-sync/out-of-sync is not subject to specification, but could e.g. be based on received burst quality or CRC checks. One example would be to have the same criteria as for the downlink synchronisation status primitives.

4.4.2.2 Radio link monitoring

4.4.2.2.1 Downlink radio link failure

The downlink radio links are monitored by the UE, to trigger radio link failure procedures. The downlink radio link failure criteria is specified in TS 25.331, and is based on the synchronisation status primitives CPHY-Sync-IND and CPHY-Out-of-Sync-IND, indicating in-sync and out-of-sync respectively.

4.4.2.2.2 Uplink radio link failure/restore

The uplink radio links are monitored by the Node B, to trigger radio link failure/restore procedures. Once the radio links have been established, they will be in the in-sync or out-of-sync states as shown in figure 1 in subclause 4.3.2.1. Transitions between those two states are described below.

The uplink radio link failure/restore criteria is based on the synchronisation status primitives CPHY-Sync-IND and CPHY-Out-of-Sync-IND, indicating in-sync and out-of-sync respectively.

When the radio links are in the in-sync state, Node B shall start timer $T_{RLFAILURE}$ after receiving $N_{OUTSYNC_IND}$ consecutive out-of-sync indications. Node B shall stop and reset timer $T_{RLFAILURE}$ upon receiving successive N_{INSYNC_IND} in-sync indications. If $T_{RLFAILURE}$ expires, Node B shall trigger the RL Failure procedure and indicate which radio links are out-of-sync. When the RL Failure procedure is triggered, the radio links' state changes to the out-of-sync state.

When the radio links are in the out-of-sync state, after receiving $N_{\text{INSYNC_IND}}$ successive in-sync indications Node B shall trigger the RL Restore procedure and indicate which radio links have re-established synchronisation. When the RL Restore procedure is triggered, the radio links' state changes to the in-sync state.

The specific parameter settings (values of $T_{\text{RLFAILURE}}$, $N_{\text{OUTSYNC_IND}}$, and $N_{\text{INSYNC_IND}}$) are configurable, see TS 25.433.

4.5 Discontinuous transmission (DTX) of Radio Frames

Discontinuous transmission (DTX) is applied in up- and downlink when the total bit rate after transport channel multiplexing differs from the total channel bit rate of the allocated dedicated physical channels.

Rate matching is used in order to fill resource units completely, that are only partially filled with data. In the case that after rate matching and multiplexing no data at all is to be transmitted in a resource unit the complete resource unit is discarded from transmission. This applies also to the case where only one resource unit is allocated and no data has to be transmitted.

When DTX is applied in the uplink and after a period of $(N_{\text{OUTSYNC_IND}} / 2) - 1$ silent frames no data has to be transmitted, then a dummy burst should be generated and transmitted in the next possible frame.

This dummy burst should have the same slot format as the normal burst where DTX is used. The dummy burst is filled with an arbitrary bit pattern, contains a TFCI and TPC bits if inner loop PC is applied. The TFCI of the dummy burst should indicate that there is no data to be transmitted.

4.6 Downlink Transmit Diversity

Downlink transmit diversity for DPCH, P-CCPCH, and SCH is optional in UTRAN. Its support is mandatory at the UE.

4.6.1 Transmit Diversity for DPCH

The transmitter structure to support transmit diversity for DPCH transmission is shown in figure 1. Channel coding, interleaving and spreading are done as in non-diversity mode. The spread complex valued signal is fed to both TX antenna branches, and weighted with antenna specific weight factors w_1 and w_2 . The weight factors are complex valued signals (i.e., $w_i = a_i + jb_i$), in general. These weight factors are calculated on a per slot and per user basis.

The weight factors are determined by the UTRAN. Examples of transmit diversity schemes are given in annex B.

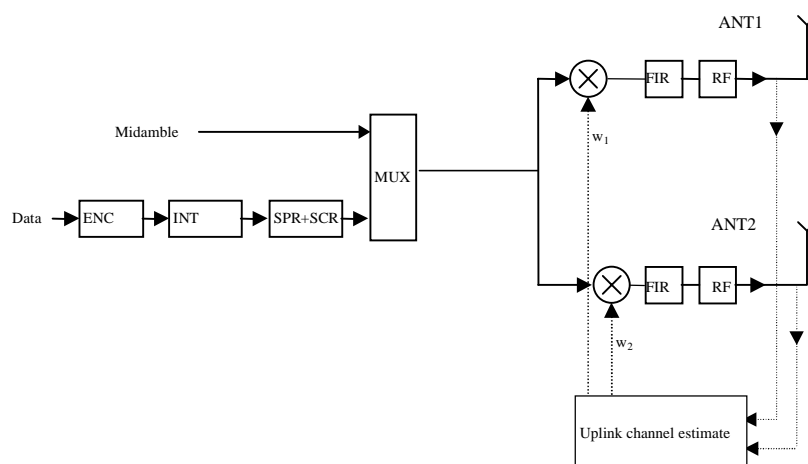

Figure 1: Downlink transmitter structure to support Transmit Diversity for DPCH transmission (UTRAN Access Point)

4.6.2 Transmit Diversity for SCH

Time Switched Transmit Diversity (TSTD) can be employed as transmit diversity scheme for the synchronisation channel.

4.6.2.1 SCH Transmission Scheme

The transmitter structure to support transmit diversity for SCH transmission is shown in figure 2. P-SCH and S-SCH are transmitted from antenna 1 and antenna 2 alternatively. An example for the antenna switching pattern is shown in figure 3.

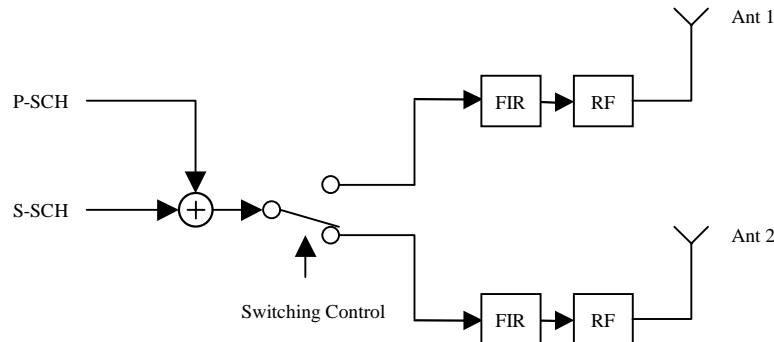

Figure 2: Downlink transmitter structure to support Transmit Diversity for SCH transmission (UTRAN Access Point)

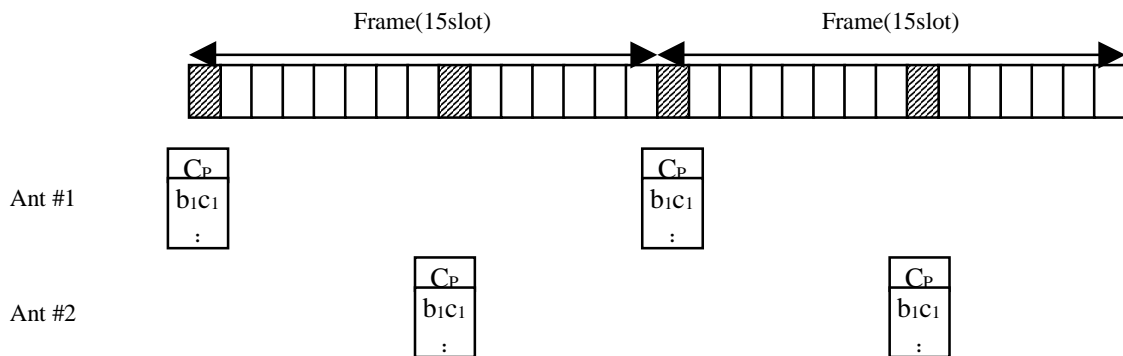

Figure 3: Antenna Switching Pattern (Case 2)

4.6.3 Transmit Diversity for P-CCPCH

Block Space Time Transmit Diversity (Block STTD) may be employed as transmit diversity scheme for the Primary Common Control Physical Channels (P-CCPCH).

4.6.3.1 P-CCPCH Transmission Scheme

The open loop downlink transmit diversity employs a Block Space Time Transmit Diversity scheme (Block STTD).

A block diagram of the Block STTD transmitter is shown in figure 4. Before Block STTD encoding, channel coding, rate matching, interleaving and bit-to-symbol mapping are performed as in the non-diversity mode.

Block STTD encoding is separately performed for each of the two data fields present in a burst (each data field contains N data symbols). For each data field at the encoder input, 2 data fields are generated at its output, corresponding to each of the diversity antennas. The Block STTD encoding operation is illustrated in figure 5, where the superscript * stands for complex conjugate. If N is an odd number, the first symbol of the block shall not be STTD encoded and the same symbol will be transmitted with equal power from both antennas.

After Block STTD encoding both branches are separately spread and scrambled as in the non-diversity mode.

The use of Block STTD encoding will be indicated by higher layers.

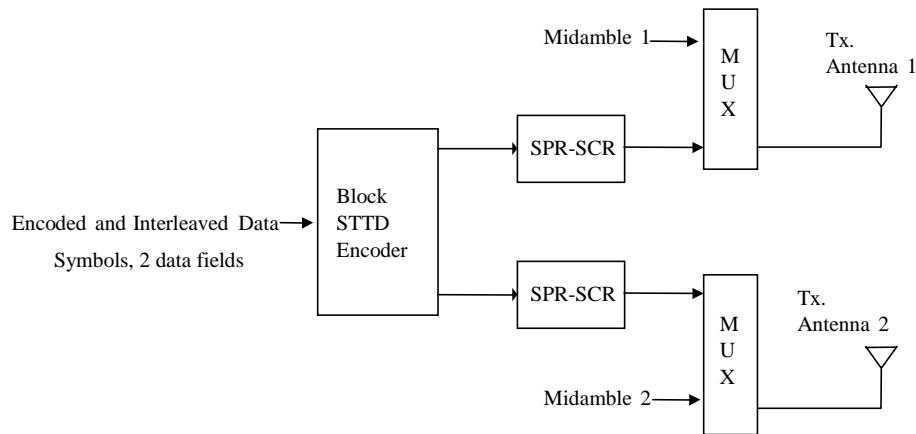

Figure 4: Block Diagram of the transmitter (STTD)

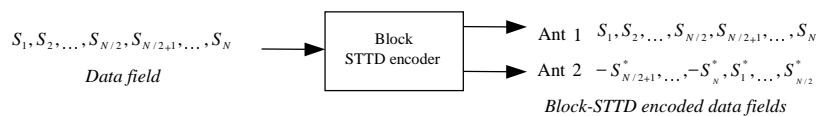

Figure 5: Block Diagram of Block STTD encoder. The symbols S_i are QPSK. N is the length of the block to be encoded

4.7 Random access procedure

The physical random access procedure described below is invoked whenever a higher layer requests transmission of a message on the RACH. The physical random access procedure is controlled by primitives from RRC and MAC. Retransmission on the RACH in case of failed transmission (e.g. due to a collision) is controlled by higher layers. Thus, the backoff algorithm and associated handling of timers is not described here. The definition of the RACH in terms of PRACH sub-channels and associated Access Service Classes is broadcasted on the BCH in each cell. Parameters for common physical channel uplink outer loop power control are also broadcasted on the BCH in each cell. The UE needs to decode this information prior to transmission on the RACH.

4.7.1 Physical random access procedure

The physical random access procedure described in this subclause is initiated upon request of a PHY-Data-REQ primitive from the MAC sublayer (cf. TS 25.321 and TS 25.303).

Before the physical random-access procedure can be initiated, Layer 1 shall receive the following information by a CPHY-TrCH-Config-REQ from the RRC layer:

- the available PRACH sub-channels for each Access Service Class (ASC);
- the timeslot, spreading factor, channelisation code, midamble, repetition period and offset for each PRACH sub-channel. (There is a 1:1 mapping between spreading code and midamble as defined by RRC);
- the set of Transport Format parameters;
- the set of parameters for common physical channel uplink outer loop power control.

NOTE: The above parameters may be updated from higher layers before each physical random access procedure is initiated. At each initiation of the physical random access procedure, Layer 1 shall receive the following information from the higher layers (MAC):

- the Transport Format to be used for the PRACH message;
- the ASC of the PRACH transmission;
- the data to be transmitted (Transport Block Set).

The physical random-access procedure shall be performed as follows.

- 1 Randomly select the PRACH sub-channel from the available ones for the given ASC. The random function shall be such that each of the allowed selections is chosen with equal probability.
- 2 Derive the available access slots in the next N frames, defined by SFN, SFN+1, ..., SFN+N-1 for the selected PRACH sub-channel with the help of SFN (where N is the repetition period of the selected PRACH sub-channel). Randomly select an uplink access slot from the available access slots in the next frame, defined by SFN, if there is one available. If there is no access slot available in the next frame, defined by SFN then, randomly select one access slot from the available access slots in the following frame, defined by SFN+1. This search is performed for all frames in increasing order, defined by SFN, SFN+1, ..., SFN+N-1, until an available access slot is found. The random function shall be such that each of the allowed selections is chosen with equal probability.
- 3 Randomly select a spreading code from the available ones for the given ASC. The random function shall be such that each of the allowed selections is chosen with equal probability. The midamble is derived from the selected spreading code.
- 4 Set the PRACH message transmission power level according to the specification for common physical channels in uplink (see subclause 4.2.2.2).
- 5 Transmit the random access message.

4.8 DSCH procedure

The physical downlink shared channel procedure described below shall be applied by the UE when the physical layer signalling either with the midamble based signalling or TFCI based signalling is used to indicate for the UE the need for PDSCH detection. There is also a third alternative to indicate to the UE the need for the PDSCH detection and this is done by means of higher layer signalling, already described in [8].

4.8.1 DSCH procedure with TFCI indication

When the UE has been allocated by higher layers to receive data on DSCH using the TFCI, the UE shall decode the PDSCH in the following cases:

- In case of a standalone PDSCH the TFCI is located on the PDSCH itself, then the UE shall decode the TFCI and based on which data rate was indicated by the TFCI, the decoding shall be performed. The UE shall decode PDSCH only if the TFCI word decode corresponds to the TFC part of the TFCS given to the UE by higher layers.
- In case that the TFCI is located on the DCH, the UE shall decode the PDSCH frame or frames if the TFCI on the DCH indicates the need for PDSCH reception. Upon reception of the DCH time slot or time slots, the PDSCH slot (or first PDSCH slot) shall start $SFN\ n+2$ after the DCH frame containing the TFCI, where n indicates the SFN on which the DCH is received. In the case that the TFCI is repeated over several frames, the PDSCH slot shall start $SFN\ n+2$ after the frame having the DCH slot which contains the last part of the repeated TFCI.

4.8.2 DSCH procedure with midamble indication

When the UE has been allocated by higher layers to receive PDSCH based on the midamble used on the PDSCH (midamble based signalling described in [8]), the UE shall operate as follows:

- The UE shall test the midamble it received and if the midamble received was the same as indicated by higher layers to correspond to PDSCH reception, the UE shall detect the PDSCH data according to the TF given by the higher layers for the UE.
- In case of multiple time slot allocation for the DSCH indicated to be part of the TF for the UE, the UE shall receive all timeslots if the midamble of the first timeslot of PDSCH was the midamble indicated to the UE by higher layers.
- In case the standalone PDSCH (no associated DCH) contains the TFCI the UE shall detect the TF indicated by the TFCI on PDSCH.

Annex A (informative): Power Control

A.1 An Example for Calculating α

This annex presents an example for calculating the path loss weighting parameter for open loop power control α .

α can be calculated as $\alpha = 1-(D-1)/6$ where D is the delay, expressed in number of slots, between the uplink slot and the most recent downlink slot. Note that $\alpha=1$ for a delay of one slot (minimal delay), and $\alpha=0$ for a delay of 7 slots (maximal delay).

A.2 Example Implementation of Downlink Power Control in the UE

The measurement of received SIR shall be carried out periodically at the UE. When the measured value is higher than the target SIR value, TPC command = "down". When this is lower than or equal to the target SIR value, TPC command = "up".

In case of a downlink transmission pause on the DPCH or PDSCH, the receive power (RSCP) of the data can no longer be used for inner loop SIR calculations in the UE. In this case the UE should trace the fluctuations of the pathloss based on the P-CCPCH and use these values instead for generating the TPC commands. This pathloss together with the timeslot ISCP measurement in the data timeslot, which is ongoing, should be used to calculate a virtual SIR value:

$$SIR_{virt}(i) = RSCP_{virt}(i) - ISCP(i),$$

$$RSCP_{virt}(i) = RSCP_0 + L_0 - L(i) + \sum_{k=1}^{i-1} TPC(k),$$

RSCP:	Received signal code power in dB
ISCP:	Interference signal code power in the DPCH / PDSCH timeslot in dB
L:	pathloss in dB measured on the P-CCPCH. The same weighting of the long- and short-term pathloss should be used as for uplink open loop power control, see Annex A.1
i:	index for the frames during a transmission pause, $1 \leq i \leq$ number of frames in the pause
L_0 :	weighted pathloss in the last frame before the transmission pause
$RSCP_0$:	RSCP of the data that was used in the SIR calculation of the last frame before the pause
TPC (k):	\pm power control stepsize in dB according to the TPC bit generated and transmitted in frame k, TPC bit "up" = +stepsize, TPC bit "down" = -stepsize

Annex B (informative): Determination of Weight Information

Selective Transmit Diversity (STD) and Transmit Adaptive Antennas (TxAA) are examples of transmit diversity schemes for dedicated physical channels.

B.1 STD Weights

The weight vector will take only two values depending on the signal strength received by each antenna in the uplink slot. For each user, the antenna receiving the highest power will be selected (i.e. the corresponding weight will be set to 1).

Table 2: STD weights for two TX antennas

	W_1	W_2
Antenna 1 receiving highest power	1	0
Antenna 2 receiving highest power	0	1

B.2 TxAA Weights

In a generic sense, the weight vector to be applied at the transmitter is the \underline{w} that maximises:

$$P = \underline{w}^H H^H H \underline{w} \quad (1)$$

where

$$H = [\underline{h}_1 \quad \underline{h}_2] \text{ and } \underline{w} = [w_1, w_2]^T$$

and where the column vector \underline{h}_i represents the estimated uplink channel impulse response for the i 'th transmission antenna, of length equal to the length of the channel impulse response.

Annex C (informative): Change history

Change history							
Date	TSG #	TSG Doc.	CR	Rev	Subject/Comment	Old	New
14/01/00	RAN_05	RP-99594	-		Approved at TSG RAN #5 and placed under Change Control	-	3.0.0
14/01/00	RAN_06	RP-99698	001	01	Primary and Secondary CCPCH in TDD	3.0.0	3.1.0
14/01/00	RAN_06	RP-99698	002	-	Measurement procedure of received reference power for OL-TPC in TDD	3.0.0	3.1.0
14/01/00	RAN_06	RP-99699	004	1	STTD capability for P-CCPCH, TDD component	3.0.0	3.1.0
14/01/00	RAN_06	RP-99697	005	1	Alignment of Terminology Regarding Spreading for TDD Mode	3.0.0	3.1.0
14/01/00	-	-	-		Change history was added by the editor	3.1.0	3.1.1
31/03/00	RAN_07	RP-000070	003	2	Cycling of cell parameters	3.1.1	3.2.0
31/03/00	RAN_07	RP-000070	007	2	Clarifications on the UL synchronisation and Timing advance	3.1.1	3.2.0
31/03/00	RAN_07	RP-000070	008	-	Modification of SIR threshold on setting TPC	3.1.1	3.2.0
31/03/00	RAN_07	RP-000070	009	1	New section describing the random access procedure	3.1.1	3.2.0
31/03/00	RAN_07	RP-000070	011	-	Removal of Synchronisation Case 3 in TDD	3.1.1	3.2.0
31/03/00	RAN_07	RP-000070	012	1	Clarifications on power control procedures	3.1.1	3.2.0
31/03/00	RAN_07	RP-000070	013	-	Signal Point Constellation	3.1.1	3.2.0
31/03/00	RAN_07	RP-000070	014	2	Out-of-sync handling for UTRA TDD	3.1.1	3.2.0
31/03/00	RAN_07	RP-000070	015	-	Removal of ODMA from the TDD specifications	3.1.1	3.2.0
26/06/00	RAN_08	RP-000274	016	-	Editorial correction for the power control section in 25.224	3.2.0	3.3.0
26/06/00	RAN_08	RP-000274	017	-	Power control for TDD during DTX	3.2.0	3.3.0
26/06/00	RAN_08	RP-000274	018	1	Power Control for PDSCH	3.2.0	3.3.0
26/06/00	RAN_08	RP-000274	020	1	Editorial modification of 25.224	3.2.0	3.3.0
26/06/00	RAN_08	RP-000274	021	-	Clarifications on TxDiversity for UTRA TDD	3.2.0	3.3.0
26/06/00	RAN_08	RP-000274	022	1	Introduction of the TDD DSCH detection procedure in TS 25.224	3.2.0	3.3.0
26/06/00	RAN_08	RP-000274	023	-	Downlink power control on timeslot basis	3.2.0	3.3.0

History

Document history		
V3.1.1	January 2000	Publication
V3.2.0	March 2000	Publication
V3.3.0	June 2000	Publication