

# ETSI TS 125 104 V4.0.0 (2001-03)

---

*Technical Specification*

**Universal Mobile Telecommunications System (UMTS);  
UTRA (BS) FDD;  
Radio transmission and Reception  
(3GPP TS 25.104 version 4.0.0 Release 4)**

---



---

**Reference**

RTS/TSGR-0425104Uv4

---

**Keywords**

UMTS

**ETSI**

---

650 Route des Lucioles  
F-06921 Sophia Antipolis Cedex - FRANCE

Tel.: +33 4 92 94 42 00 Fax: +33 4 93 65 47 16

Siret N° 348 623 562 00017 - NAF 742 C  
Association à but non lucratif enregistrée à la  
Sous-Préfecture de Grasse (06) N° 7803/88

---

**Important notice**

Individual copies of the present document can be downloaded from:

<http://www.etsi.org>

The present document may be made available in more than one electronic version or in print. In any case of existing or perceived difference in contents between such versions, the reference version is the Portable Document Format (PDF). In case of dispute, the reference shall be the printing on ETSI printers of the PDF version kept on a specific network drive within ETSI Secretariat.

Users of the present document should be aware that the document may be subject to revision or change of status. Information on the current status of this and other ETSI documents is available at <http://www.etsi.org/tb/status/>

If you find errors in the present document, send your comment to:  
editor@etsi.fr

---

**Copyright Notification**

No part may be reproduced except as authorized by written permission.  
The copyright and the foregoing restriction extend to reproduction in all media.

© European Telecommunications Standards Institute 2001.

All rights reserved.

---

## Intellectual Property Rights

IPRs essential or potentially essential to the present document may have been declared to ETSI. The information pertaining to these essential IPRs, if any, is publicly available for **ETSI members and non-members**, and can be found in ETSI SR 000 314: "*Intellectual Property Rights (IPRs); Essential, or potentially Essential, IPRs notified to ETSI in respect of ETSI standards*", which is available from the ETSI Secretariat. Latest updates are available on the ETSI Web server (<http://www.etsi.org/ipr>).

Pursuant to the ETSI IPR Policy, no investigation, including IPR searches, has been carried out by ETSI. No guarantee can be given as to the existence of other IPRs not referenced in ETSI SR 000 314 (or the updates on the ETSI Web server) which are, or may be, or may become, essential to the present document.

---

## Foreword

This Technical Specification (TS) has been produced by the ETSI 3<sup>rd</sup> Generation Partnership Project (3GPP).

The present document may refer to technical specifications or reports using their 3GPP identities, UMTS identities or GSM identities. These should be interpreted as being references to the corresponding ETSI deliverables.

The cross reference between GSM, UMTS, 3GPP and ETSI identities can be found under [www.etsi.org/key](http://www.etsi.org/key).

---

# Contents

Foreword.....	6
1 Scope .....	6
2 References .....	6
3 Definitions and abbreviations.....	7
3.1 Definitions.....	7
3.2 Abbreviations.....	7
4 General .....	8
4.1 Relationship between Minimum Requirements and Test Requirements.....	8
4.2 Base station classes .....	8
4.3 Regional requirements .....	9
4.4 Environmental requirements for the BS equipment .....	10
5 Frequency bands and channel arrangement.....	10
5.1 General.....	10
5.2 Frequency bands.....	10
5.3 Tx-Rx frequency separation .....	10
5.4 Channel arrangement .....	10
5.4.1 Channel spacing.....	10
5.4.2 Channel raster.....	11
5.4.3 Channel number.....	11
6 Transmitter characteristics.....	11
6.1 General.....	11
6.2 Base station output power .....	11
6.2.1 Base station maximum output power .....	11
6.2.1.1 Minimum requirement.....	12
6.3 Frequency error .....	12
6.3.1 Minimum requirement.....	12
6.4 Output power dynamics .....	12
6.4.1 Inner loop power control in the downlink .....	12
6.4.1.1 Power control steps.....	12
6.4.1.1.1 Minimum requirement .....	12
6.4.2 Power control dynamic range.....	13
6.4.2.1 Minimum requirements .....	13
6.4.3 Total power dynamic range .....	13
6.4.3.1 Minimum requirement.....	13
6.4.4 Primary CPICH power .....	13
6.4.4.1 Requirement .....	13
6.5 (void).....	13
6.6 Output RF spectrum emissions .....	13
6.6.1 Occupied bandwidth.....	13
6.6.2 Out of band emission.....	14
6.6.2.1 Spectrum emission mask .....	14
6.6.2.2 Adjacent Channel Leakage power Ratio (ACLR).....	15
6.6.2.2.1 Minimum requirement .....	15
6.6.3 Spurious emissions .....	16
6.6.3.1 Mandatory Requirements .....	16
6.6.3.1.1 Spurious emissions (Category A) .....	16
6.6.3.1.2 Spurious emissions (Category B).....	16
6.6.3.2 Protection of the BS receiver.....	17
6.6.3.2.1 Minimum Requirement.....	17
6.6.3.3 Co-existence with GSM 900.....	18
6.6.3.3.1 Operation in the same geographic area .....	18
6.6.3.3.2 Co-located base stations.....	18
6.6.3.4 Co-existence with DCS 1800 .....	18

6.6.3.4.1	Operation in the same geographic area .....	18
6.6.3.4.2	Co-located base stations .....	18
6.6.3.5	Co-existence with PHS .....	19
6.6.3.5.1	Minimum Requirement .....	19
6.6.3.6	Co-existence with services in adjacent frequency bands .....	19
6.6.3.6.1	Minimum requirement .....	19
6.6.3.7	Co-existence with UTRA-TDD .....	19
6.6.3.7.1	Operation in the same geographic area .....	19
6.6.3.7.2	Co-located base stations .....	20
6.7	Transmit intermodulation .....	20
6.7.1	Minimum requirement .....	20
6.8	Transmit modulation .....	20
6.8.1	Transmit pulse shape filter .....	20
6.8.2	Error Vector Magnitude .....	21
6.8.2.1	Minimum requirement .....	21
6.8.3	Peak code Domain error .....	21
6.8.3.1	Minimum requirement .....	21
7	Receiver characteristics .....	21
7.1	General .....	21
7.2	Reference sensitivity level .....	22
7.2.1	Minimum requirement .....	22
7.2.2	Maximum Frequency Deviation for Receiver Performance .....	22
7.3	Dynamic range .....	22
7.3.1	Minimum requirement .....	22
7.4	Adjacent Channel Selectivity (ACS) .....	23
7.4.1	Minimum requirement .....	23
7.5	Blocking characteristics .....	23
7.5.1	Minimum requirement .....	23
7.5.2	Minimum Requirement – Co-location with GSM900 and/or DCS 1800 .....	24
7.6	Intermodulation characteristics .....	24
7.6.1	Minimum requirement .....	24
7.7	Spurious emissions .....	25
7.7.1	Minimum requirement .....	25
8	Performance requirement .....	25
8.1	General .....	25
8.2	Demodulation in static propagation conditions .....	26
8.2.1	Demodulation of DCH .....	26
8.2.1.1	Minimum requirement .....	26
8.3	Demodulation of DCH in multipath fading conditions .....	26
8.3.1	Multipath fading Case 1 .....	26
8.3.1.1	Minimum requirement .....	26
8.3.2	Multipath fading Case 2 .....	26
8.3.2.1	Minimum requirement .....	27
8.3.3	Multipath fading Case 3 .....	27
8.3.3.1	Minimum requirement .....	27
8.3.4	Multipath fading Case 4 .....	27
8.3.4.1	Minimum requirement .....	27
8.4	Demodulation of DCH in moving propagation conditions .....	28
8.4.1	Minimum requirement .....	28
8.5	Demodulation of DCH in birth/death propagation conditions .....	28
8.5.1	Minimum requirement .....	28
8.6	BS Functionality in Site Selection Diversity Transmission (SSDT) Mode .....	29
8.6.1	Minimum requirements .....	29
8.7	Performance requirement for RACH .....	29
8.7.1	Performance requirement for RACH preamble detection .....	29
8.7.2	Demodulation of RACH message .....	30
8.7.2.1	Minimum requirements for Static Propagation Condition .....	30
8.7.2.2	Minimum requirements for Multipath Fading Case 3 .....	30

<b>Annex A (normative):</b>	<b>Measurement channels</b> .....	<b>31</b>
A.1	Summary of UL reference measurement channels .....	31
A.2	UL reference measurement channel for 12.2 kbps .....	32
A.3	UL reference measurement channel for 64 kbps .....	33
A.4	UL reference measurement channel for 144 kbps .....	34
A.5	UL reference measurement channel for 384 kbps .....	35
A.6	UL reference measurement channel for 2048 kbps .....	36
<b>Annex B (normative):</b>	<b>Propagation conditions</b> .....	<b>37</b>
B.1	Static propagation condition .....	37
B.2	Multi-path fading propagation conditions .....	37
B.3	Moving propagation conditions .....	37
B.4	Birth-Death propagation conditions .....	38
<b>Annex C (informative):</b>	<b>Change history</b> .....	<b>39</b>
<b>Annex D (informative):</b>	<b>Change request history</b> .....	<b>40</b>

---

# Foreword

This Technical Specification has been produced by the 3GPP.

The contents of the present document are subject to continuing work within the TSG and may change following formal TSG approval. Should the TSG modify the contents of this TS, it will be re-released by the TSG with an identifying change of release date and an increase in version number as follows:

Version 3.y.z

where:

- x the first digit:
  - 1 presented to TSG for information;
  - 2 presented to TSG for approval;
  - 3 Indicates TSG approved document under change control.
- y the second digit is incremented for all changes of substance, i.e. technical enhancements, corrections, updates, etc.
- z the third digit is incremented when editorial only changes have been incorporated in the specification.

---

## 1 Scope

This document establishes the Base Station minimum RF characteristics of the FDD mode of UTRA.

---

## 2 References

The following documents contain provisions, which, through reference in this text, constitute provisions of the present document.

- References are either specific (identified by date of publication, edition number, version number, etc.) or non-specific.
- For a specific reference, subsequent revisions do not apply.
- For a non-specific reference, subsequent revisions do apply. In the case of a reference to a 3GPP document (including a GSM document), a non-specific reference implicitly refers to the latest version of that document in the same Release as the present document.
- A non-specific reference to an ETS shall also be taken to refer to later versions published as an EN with the same number.

[1] ITU-R Recommendation SM.329-8, "Spurious emissions".

[2] (void)

[3] ETSI ETR 273-1-2: "Electromagnetic compatibility and Radio spectrum Matters (ERM); Improvement of radiated methods of measurement (using test sites) and evaluation of the corresponding measurement uncertainties; Part 1: Uncertainties in the measurement of mobile radio equipment characteristics; Sub-part 2: Examples and annexes".

## 3 Definitions and abbreviations

### 3.1 Definitions

For the purposes of the present document, the following definitions apply:

**Output power:** The mean power of one carrier of the base station, delivered to a load with resistance equal to the nominal load impedance of the transmitter.

**Rated output power:** Rated output power of the base station is the mean power level per carrier that the manufacturer has declared to be available at the antenna connector.

**Maximum output Power:** The mean power level per carrier of the base station measured at the antenna connector in a specified reference condition.

**Power control dynamic range:** The difference between the maximum and the minimum transmit output power of a code channel for a specified reference condition.

**Total power dynamic range:** The difference between the maximum and the minimum total transmit output power for a specified reference condition.

### 3.2 Abbreviations

For the purposes of the present document, the following abbreviations apply:

ACIR	Adjacent Channel Interference Ratio
ACLR	Adjacent Channel Leakage power Ratio
ACS	Adjacent Channel Selectivity
BS	Base Station
BER	Bit Error Ratio
BLER	Block Error Ratio
CW	Continuous Wave (unmodulated signal)
DL	Down Link (forward link)
FDD	Frequency Division Duplexing
GSM	Global System for Mobile Communications
$P_{out}$	Output Power
$P_{RAT}$	Rated Output Power
PHS	Personal Handyphone System
PPM	Parts Per Million
RSSI	Received Signal Strength Indicator
SIR	Signal to Interference ratio
TDD	Time Division Duplexing
TPC	Transmit Power Control
UARFCN	UTRA Absolute Radio Frequency Channel Number
UE	User Equipment
UL	Up Link (reverse link)
WCDMA	Wideband Code Division Multiple Access



---

## 4 General

### 4.1 Relationship between Minimum Requirements and Test Requirements

The Minimum Requirements given in this specification make no allowance for measurement uncertainty. The test specification 25.141 section 4 defines Test Tolerances. These Test Tolerances are individually calculated for each test. The Test Tolerances are used to relax the Minimum Requirements in this specification to create Test Requirements.

The measurement results returned by the Test System are compared - without any modification - against the Test Requirements as defined by the shared risk principle.

The Shared Risk principle is defined in ETR 273 Part 1 sub-part 2 section 6.5.

### 4.2 Base station classes

The requirements in this specification apply to base station intended for general-purpose applications.

In the future further classes of base stations may be defined; the requirements for these may be different than for general-purpose applications.

## 4.3 Regional requirements

Some requirements in TS 25.104 may only apply in certain regions. Table 4.1 lists all requirements that may be applied differently in different regions.

**Table 4.1: List of regional requirements.**

Clause number	Requirement	Comments
5.2	Frequency bands	Some bands may be applied regionally.
5.3	Tx-Rx Frequency Separation	The requirement is applied according to what frequency bands in Clause 5.2 that are supported by the BS.
6.2.1	Base station maximum output power	In certain regions, the minimum requirement for normal conditions may apply also for some conditions outside the range of conditions defined as normal.
6.6.2.1	Spectrum emission mask	The mask specified may be mandatory in certain regions. In other regions this mask may not be applied.
6.6.2.3	Protection outside a licensee's frequency block	This requirement is applicable if protection is required outside a licensee's frequency block.
6.6.3.1.1	Spurious emissions (Category A)	These requirements shall be met in cases where Category A limits for spurious emissions, as defined in ITU-R Recommendation SM.329-8 [1], are applied.
6.6.3.1.2	Spurious emissions (Category B)	These requirements shall be met in cases where Category B limits for spurious emissions, as defined in ITU-R Recommendation SM.329-8 [1], are applied.
6.6.3.3.1	Co-existence with GSM900 -Operation in the same geographic area	This requirement may be applied for the protection of GSM 900 MS in geographic areas in which both GSM 900 and UTRA are deployed.
6.6.3.3.2	Co-existence with GSM900 - Co-located base stations	This requirement may be applied for the protection of GSM 900 BTS receivers when GSM 900 BTS and UTRA BS are co-located.
6.6.3.4.1	Co-existence with DCS1800 -Operation in the same geographic area	This requirement may be applied for the protection of DCS 1800 MS in geographic areas in which both DCS 1800 and UTRA are deployed.
6.6.3.4.2	Co-existence with DCS1800 - Co-located base stations	This requirement may be applied for the protection of DCS 1800 BTS receivers when DCS 1800 BTS and UTRA BS are co-located.
6.6.3.5	Co-existence with PHS	This requirement may be applied for the protection of PHS in geographic areas in which both PHS and UTRA are deployed.
6.6.3.6	Co-existence with services in adjacent frequency bands	This requirement may be applied for the protection in bands adjacent to 2110-2170 MHz, as defined in sub-clause 5.2(a) and 1930-1990 MHz, as defined in sub-clause 5.2(b) in geographic areas in which both an adjacent band service and UTRA are deployed.
6.6.3.7.1	Co-existence with UTRA TDD - Operation in the same geographic area	This requirement may be applied to geographic areas in which both UTRA-TDD and UTRA-FDD are deployed.
6.6.3.7.2	Co-existence with UTRA TDD - Co-located base stations	This requirement may be applied for the protection of UTRA-TDD BS receivers when UTRA-TDD BS and UTRA FDD BS are co-located.
7.5	Blocking characteristic	The requirement is applied according to what frequency bands in Clause 5.2 that are supported by the BS.
7.5.2	Blocking characteristics Co-location with GSM900 and/or DCS 1800	This requirement may be applied for the protection of UTRA FDD BS receivers when UTRA FDD BS and GSM 900/DCS1800 BS are co-located.

## 4.4 Environmental requirements for the BS equipment

The BS equipment shall fulfil all the requirements in the full range of environmental conditions for the relevant environmental class from the relevant IEC specifications listed below

60 721-3-3 “Stationary use at weather protected locations”

60 721-3-4 “Stationary use at non weather protected locations”

Normally it should be sufficient for all tests to be conducted using normal test conditions except where otherwise stated. For guidance on the use of test conditions to be used in order to show compliance refer to TS 25.141.

---

## 5 Frequency bands and channel arrangement

### 5.1 General

The information presented in this section is based on a chip rate of 3.84 Mcps.

NOTE 1: Other chip rates may be considered in future releases.

### 5.2 Frequency bands

UTRA/FDD is designed to operate in either of the following paired bands;

- (a) 1920 - 1980MHz: Up-link (Mobile transmit, base receive)  
2110 - 2170MHz: Down-link (Base transmit, mobile receive)
- (b) 1850 - 1910MHz: Up-link (Mobile transmit, base receive)  
1930 - 1990MHz: Down-link (Base transmit, mobile receive)  
(Note 1)

NOTE 1: Used in Region 2. Additional allocations in ITU region 2 are FFS.

NOTE 2: Deployment in other frequency bands is not precluded.

### 5.3 Tx-Rx frequency separation

- (a) The minimum transmit to receive frequency separation is 134.8 MHz and the maximum value is 245.2 MHz and all UE(s) shall support a TX -RX frequency separation of 190 MHz when operating in the paired band defined in sub-clause 5.2(a).
- (b) UTRA/FDD can support both fixed and variable transmit to receive frequency separation.
- (c) When operating in the paired band defined in sub-clause 5.2(b), all UE(s) shall support a TX - RX frequency separation of 80 MHz.
- (d) The use of other transmit to receive frequency separations in existing or other frequency bands shall not be precluded.

### 5.4 Channel arrangement

#### 5.4.1 Channel spacing

The nominal channel spacing is 5 MHz, but this can be adjusted to optimise performance in a particular deployment scenario.

## 5.4.2 Channel raster

The channel raster is 200 kHz, which means that the center frequency must be an integer multiple of 200 kHz.

## 5.4.3 Channel number

The carrier frequency is designated by the UTRA Absolute Radio Frequency Channel Number (UARFCN). The value of the UARFCN in the IMT2000 band is defined as follows:

**Table 5.1: UTRA Absolute Radio Frequency Channel Number**

Uplink	$N_u = 5 * F_{\text{uplink}}$	$0.0 \text{ MHz} \leq F_{\text{uplink}} \leq 3276.6 \text{ MHz}$ where $F_{\text{uplink}}$ is the uplink frequency in MHz
Downlink	$N_d = 5 * F_{\text{downlink}}$	$0.0 \text{ MHz} \leq F_{\text{downlink}} \leq 3276.6 \text{ MHz}$ where $F_{\text{downlink}}$ is the downlink frequency in MHz

# 6 Transmitter characteristics

## 6.1 General

Unless otherwise stated, the transmitter characteristics are specified at the BS antenna connector (test port A) with a full complement of transceivers for the configuration in normal operating conditions. If any external apparatus such as a TX amplifier, a diplexer, a filter or the combination of such devices is used, requirements apply at the far end antenna connector (port B).

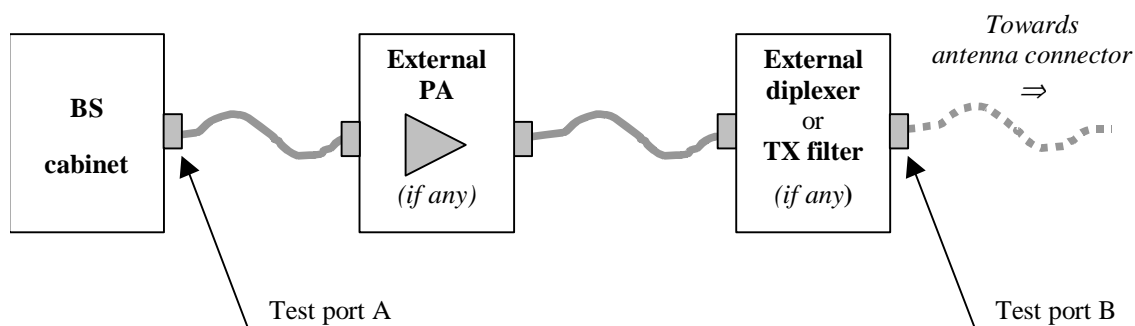

**Figure 6.1: Transmitter test ports**

## 6.2 Base station output power

Output power,  $P_{\text{out}}$ , of the base station is the mean power of one carrier delivered to a load with resistance equal to the nominal load impedance of the transmitter.

Rated output power,  $PRAT$ , of the base station is the mean power level per carrier that the manufacturer has declared to be available at the antenna connector.

### 6.2.1 Base station maximum output power

Maximum output power,  $P_{\text{max}}$ , of the base station is the mean power level per carrier measured at the antenna connector in specified reference condition.

### 6.2.1.1 Minimum requirement

In normal conditions, the Base station maximum output power shall remain within +2 dB and -2dB of the manufacturer's rated output power.

In extreme conditions, the Base station maximum output power shall remain within +2.5 dB and -2.5 dB of the manufacturer's rated output power.

In certain regions, the minimum requirement for normal conditions may apply also for some conditions outside the range of conditions defined as normal.

## 6.3 Frequency error

The same source shall be used for RF frequency and data clock generation.

### 6.3.1 Minimum requirement

The modulated carrier frequency of the BS shall be accurate to within  $\pm 0.05$  ppm observed over a period of one power control group (timeslot).

## 6.4 Output power dynamics

Power control is used to limit the interference level. The transmitter uses a quality-based power control on both the uplink and downlink.

### 6.4.1 Inner loop power control in the downlink

Inner loop power control in the downlink is the ability of the BS transmitter to adjust the transmitter output power of a code channel in accordance with the corresponding TPC symbols received in the uplink.

#### 6.4.1.1 Power control steps

The power control step is the required step change in the DL transmitter output power of a code channel in response to the corresponding power control command. The aggregated output power change is the required total change in the DL transmitter output power of a code channel in response to multiple consecutive power control commands corresponding to that code channel.

##### 6.4.1.1.1 Minimum requirement

The BS transmitter shall have the capability of setting the inner loop output power with a step sizes of 1dB mandatory and 0.5 dB optional

- (a) The power control step due to inner loop power control shall be within the range shown in Table 6.1.
- (b) The aggregated output power change due to inner loop power control shall be within the range shown in Table 6.2.

**Table 6.1: Transmitter power control step range**

Power control commands in the down link	Transmitter power control step range			
	1 dB step size		0.5 dB step size	
	Lower	Upper	Lower	Upper
Up (TPC command "1")	+0.5 dB	+1.5 dB	+0.25 dB	+0.75 dB
Down (TPC command "0")	-0.5 dB	-1.5 dB	-0.25 dB	-0.75 dB

**Table 6.2: Transmitter aggregated output power change range**

Power control commands in the down link	Transmitter aggregated output power change range after 10 consecutive equal commands (up or down)			
	1 dB step size		0.5dB step size	
	Lower	Upper	Lower	Upper
Up (TPC command "1")	+8 dB	+12 dB	+4 dB	+6 dB
Down (TPC command "0")	-8 dB	-12 dB	-4 dB	-6 dB

## 6.4.2 Power control dynamic range

The power control dynamic range is the difference between the maximum and the minimum transmit output power of a code channel for a specified reference condition.

### 6.4.2.1 Minimum requirements

Down link (DL) power control dynamic range:

Maximum power: BS maximum output power - 3 dB or greater

Minimum power: BS maximum output power - 28 dB or less

## 6.4.3 Total power dynamic range

The total power dynamic range is the difference between the maximum and the minimum total transmit output power for a specified reference condition.

NOTE: The upper limit of the dynamic range is the BS maximum output power. The lower limit of the dynamic range is the lowest minimum power from the BS when no traffic channels are activated.

### 6.4.3.1 Minimum requirement

The downlink (DL) total power dynamic range shall be 18 dB or greater.

## 6.4.4 Primary CPICH power

Primary CPICH power is the transmission power of the Common Pilot Channel averaged over one frame.

Primary CPICH power is indicated on the BCH.

### 6.4.4.1 Requirement

CPICH power shall be within  $\pm 2.1$ dB of the value indicated by a signalling message.

## 6.5 (void)

## 6.6 Output RF spectrum emissions

### 6.6.1 Occupied bandwidth

Occupied bandwidth is a measure of the bandwidth containing 99% of the total integrated power for transmitted spectrum and is centered on the assigned channel frequency. The occupied channel bandwidth shall be less than 5 MHz based on a chip rate of 3.84 Mcps.

## 6.6.2 Out of band emission

Out of band emissions are unwanted emissions immediately outside the channel bandwidth resulting from the modulation process and non-linearity in the transmitter but excluding spurious emissions. This out of band emission requirement is specified both in terms of a spectrum emission mask and adjacent channel power ratio for the transmitter.

### 6.6.2.1 Spectrum emission mask

The mask defined in Tables 6.3 to 6.6 below may be mandatory in certain regions. In other regions this mask may not be applied.

For regions where this clause applies, the requirement shall be met by a base station transmitting on a single RF carrier configured in accordance with the manufacturer’s specification. Emissions shall not exceed the maximum level specified in tables 6.3 to 6.6 for the appropriate BS maximum output power, in the frequency range from  $\Delta f = 2.5$  MHz to  $f_{\text{offset\_max}}$  from the carrier frequency, where:

- $\Delta f$  is the separation between the carrier frequency and the nominal -3dB point of the measuring filter closest to the carrier frequency.
- $F_{\text{offset}}$  is the separation between the carrier frequency and the centre of the measuring filter.
- $f_{\text{offset\_max}}$  is either 12.5 MHz or the offset to the UMTS Tx band edge as defined in section 5.2, whichever is the greater.

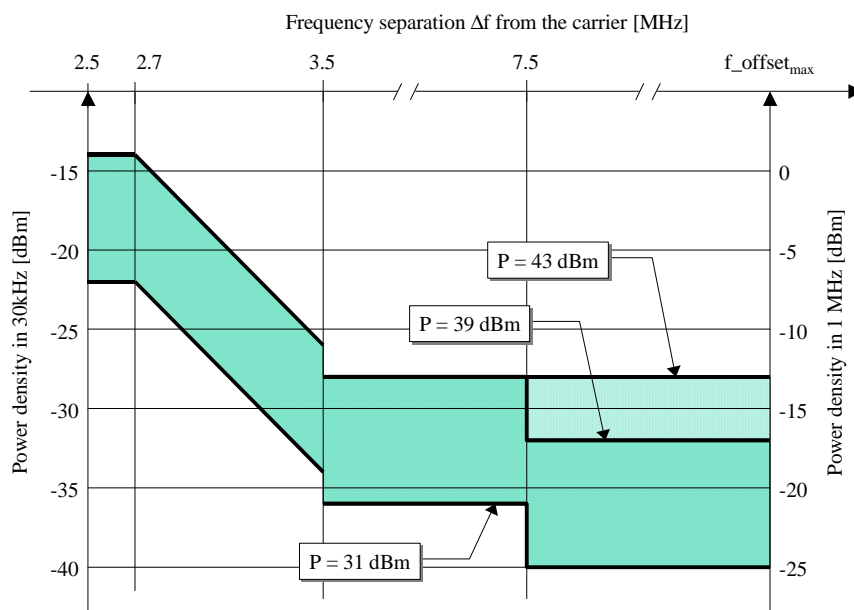

Illustrative diagram of spectrum emission mask

Figure 6.2: Spectrum emission mask

Table 6.3: Spectrum emission mask values, BS maximum output power  $P \geq 43$  dBm

Frequency offset of measurement filter -3dB point, $\Delta f$	Frequency offset of measurement filter centre frequency, $f_{\text{offset}}$	Maximum level	Measurement bandwidth
$2.5 \leq \Delta f < 2.7$ MHz	$2.515\text{MHz} \leq f_{\text{offset}} < 2.715\text{MHz}$	-14 dBm	30 kHz
$2.7 \leq \Delta f < 3.5$ MHz	$2.715\text{MHz} \leq f_{\text{offset}} < 3.515\text{MHz}$	$-14 - 15 \cdot (f_{\text{offset}} - 2.715)$ dBm	30 kHz
	$3.515\text{MHz} \leq f_{\text{offset}} < 4.0\text{MHz}$	-26 dBm	30 kHz
$3.5 \leq \Delta f$ MHz	$4.0\text{MHz} \leq f_{\text{offset}} < f_{\text{offset\_max}}$	-13 dBm	1 MHz

**Table 6.4: Spectrum emission mask values, BS maximum output power  $39 \leq P < 43$  dBm**

Frequency offset of measurement filter -3dB point, $\Delta f$	Frequency offset of measurement filter centre frequency, $f_{\text{offset}}$	Maximum level	Measurement bandwidth
$2.5 \leq \Delta f < 2.7$ MHz	$2.515\text{MHz} \leq f_{\text{offset}} < 2.715\text{MHz}$	-14 dBm	30 kHz
$2.7 \leq \Delta f < 3.5$ MHz	$2.715\text{MHz} \leq f_{\text{offset}} < 3.515\text{MHz}$	$-14 - 15 \cdot (f_{\text{offset}} - 2.715)$ dBm	30 kHz
(see note)	$3.515\text{MHz} \leq f_{\text{offset}} < 4.0\text{MHz}$	-26 dBm	30 kHz
$3.5 \leq \Delta f < 7.5$ MHz	$4.0\text{MHz} \leq f_{\text{offset}} < 8.0\text{MHz}$	-13 dBm	1 MHz
$7.5 \leq \Delta f$ MHz	$8.0\text{MHz} \leq f_{\text{offset}} < f_{\text{offset}_{\text{max}}}$	$P - 56$ dBm	1 MHz

**Table 6.5: Spectrum emission mask values, BS maximum output power  $31 \leq P < 39$  dBm**

Frequency offset of measurement filter -3dB point, $\Delta f$	Frequency offset of measurement filter centre frequency, $f_{\text{offset}}$	Maximum level	Measurement bandwidth
$2.5 \leq \Delta f < 2.7$ MHz	$2.515\text{MHz} \leq f_{\text{offset}} < 2.715\text{MHz}$	$P - 53$ dBm	30 kHz
$2.7 \leq \Delta f < 3.5$ MHz	$2.715\text{MHz} \leq f_{\text{offset}} < 3.515\text{MHz}$	$P - 53 - 15 \cdot (f_{\text{offset}} - 2.715)$ dBm	30 kHz
(see note)	$3.515\text{MHz} \leq f_{\text{offset}} < 4.0\text{MHz}$	$P - 65$ dBm	30 kHz
$3.5 \leq \Delta f < 7.5$ MHz	$4.0\text{MHz} \leq f_{\text{offset}} < 8.0\text{MHz}$	$P - 52$ dBm	1 MHz
$7.5 \leq \Delta f$ MHz	$8.0\text{MHz} \leq f_{\text{offset}} < f_{\text{offset}_{\text{max}}}$	$P - 56$ dBm	1 MHz

**Table 6.6: Spectrum emission mask values, BS maximum output power  $P < 31$  dBm**

Frequency offset of measurement filter -3dB point, $\Delta f$	Frequency offset of measurement filter centre frequency, $f_{\text{offset}}$	Maximum level	Measurement bandwidth
$2.5 \leq \Delta f < 2.7$ MHz	$2.515\text{MHz} \leq f_{\text{offset}} < 2.715\text{MHz}$	-22 dBm	30 kHz
$2.7 \leq \Delta f < 3.5$ MHz	$2.715\text{MHz} \leq f_{\text{offset}} < 3.515\text{MHz}$	$-22 - 15 \cdot (f_{\text{offset}} - 2.715)$ dBm	30 kHz
(see note)	$3.515\text{MHz} \leq f_{\text{offset}} < 4.0\text{MHz}$	-34 dBm	30 kHz
$3.5 \leq \Delta f < 7.5$ MHz	$4.0\text{MHz} \leq f_{\text{offset}} < 8.0\text{MHz}$	-21 dBm	1 MHz
$7.5 \leq \Delta f$ MHz	$8.0\text{MHz} \leq f_{\text{offset}} < f_{\text{offset}_{\text{max}}}$	-25 dBm	1 MHz

NOTE: This frequency range ensures that the range of values of  $f_{\text{offset}}$  is continuous.

### 6.6.2.2 Adjacent Channel Leakage power Ratio (ACLR)

Adjacent Channel Leakage power Ratio (ACLR) is the ratio of the transmitted power to the power measured in an adjacent channel. Both the transmitted power and the adjacent channel power are measured through a matched filter (Root Raised Cosine and roll-off 0.22) with a noise power bandwidth equal to the chip rate. The requirements shall apply for all configurations of BS (single carrier or multiple carrier), and for all operating modes foreseen by the manufacturer's specification.

#### 6.6.2.2.1 Minimum requirement

The ACLR shall be higher than the value specified in Table 6.7.

**Table 6.7: BS ACLR**

BS adjacent channel offset below the first or above the last carrier frequency used	ACLR limit
5 MHz	45 dB
10 MHz	50 dB



### 6.6.3 Spurious emissions

Spurious emissions are emissions which are caused by unwanted transmitter effects such as harmonics emission, parasitic emission, intermodulation products and frequency conversion products, but exclude out of band emissions. This is measured at the base station RF output port.

Unless otherwise stated, all requirements are measured as mean power.

#### 6.6.3.1 Mandatory Requirements

The requirements of either subclause 6.6.3.1.1 or subclause 6.6.3.1.2 shall apply whatever the type of transmitter considered (single carrier or multiple-carrier). It applies for all transmission modes foreseen by the manufacturer's specification.

Either requirement applies at frequencies within the specified frequency ranges that are more than 12.5MHz below the first carrier frequency used or more than 12.5MHz above the last carrier frequency used.

##### 6.6.3.1.1 Spurious emissions (Category A)

The following requirements shall be met in cases where Category A limits for spurious emissions, as defined in ITU-R Recommendation SM.329-8 [1], are applied.

###### 6.6.3.1.1.1 Minimum Requirement

The power of any spurious emission shall not exceed:

**Table 6.8: BS Mandatory spurious emissions limits, Category A**

Band	Maximum level	Measurement Bandwidth	Note
9kHz - 150kHz	-13 dBm	1 kHz	Bandwidth as in ITU-R SM.329-8, s4.1
150kHz - 30MHz		10 kHz	Bandwidth as in ITU-R SM.329-8, s4.1
30MHz - 1GHz		100 kHz	Bandwidth as in ITU-R SM.329-8, s4.1
1GHz - 12.75 GHz		1 MHz	Upper frequency as in ITU-R SM.329-8, s2.5 table 1

##### 6.6.3.1.2 Spurious emissions (Category B)

The following requirements shall be met in cases where Category B limits for spurious emissions, as defined in ITU-R Recommendation SM.329-8 [1], are applied.

###### 6.6.3.1.2.1 Minimum Requirement

The power of any spurious emission shall not exceed:

**Table 6.9: BS Mandatory spurious emissions limits, Category B**

Band	Maximum Level	Measurement Bandwidth	Note
9kHz ↔ 150kHz	-36 dBm	1 kHz	Bandwidth as in ITU-R SM.329-8, s4.1
150kHz ↔ 30MHz	- 36 dBm	10 kHz	Bandwidth as in ITU-R SM.329-8, s4.1
30MHz ↔ 1GHz	-36 dBm	100 kHz	Bandwidth as in ITU-R SM.329-8, s4.1
1GHz ↔ Fc1 - 60 MHz or 2100 MHz <i>whichever is the higher</i>	-30 dBm	1 MHz	Bandwidth as in ITU-R SM.329-8, s4.1
Fc1 - 60 MHz or 2100 MHz <i>whichever is the higher</i> ↔ Fc1 - 50 MHz or 2100 MHz <i>whichever is the higher</i>	-25 dBm	1 MHz	Specification in accordance with ITU-R SM.329-8, s4.3 and Annex 7
Fc1 - 50 MHz or 2100 MHz <i>whichever is the higher</i> ↔ Fc2 + 50 MHz or 2180 MHz <i>whichever is the lower</i>	-15 dBm	1 MHz	Specification in accordance with ITU-R SM.329-8, s4.3 and Annex 7
Fc2 + 50 MHz or 2180 MHz <i>whichever is the lower</i> ↔ Fc2 + 60 MHz or 2180 MHz <i>whichever is the lower</i>	-25 dBm	1 MHz	Specification in accordance with ITU-R SM.329-8, s4.3 and Annex 7
Fc2 + 60 MHz or 2180 MHz <i>whichever is the lower</i> ↔ 12.75 GHz	-30 dBm	1 MHz	Bandwidth as in ITU-R SM.329-7, s4.1. Upper frequency as in ITU-R SM.329-8, s2.5 table 1

Fc1: Center frequency of emission of the first carrier transmitted by the BS.

Fc2: Center frequency of emission of the last carrier transmitted by the BS.

### 6.6.3.2 Protection of the BS receiver

This requirement may be applied in order to prevent the receiver of the BS being desensitised by emissions from the BS transmitter, which are coupled between the antennas of the BS. This is measured at the transmit antenna port.

#### 6.6.3.2.1 Minimum Requirement

The power of any spurious emission shall not exceed:

**Table 6.10: BS Spurious emissions limits for protection of the BS receiver**

Band	Maximum Level	Measurement Bandwidth	Note
1920 - 1980MHz For operation in Frequency Bands defined in sub-clause 5.2(a)	-96 dBm	100 kHz	
1850-1910 MHz For operation in Frequency Bands defined in sub-clause 5.2(b)	-96 dBm	100kHz	

### 6.6.3.3 Co-existence with GSM 900

#### 6.6.3.3.1 Operation in the same geographic area

This requirement may be applied for the protection of GSM 900 MS in geographic areas in which both GSM 900 and UTRA are deployed.

##### 6.6.3.3.1.1 Minimum Requirement

The power of any spurious emission shall not exceed:

**Table 6.11: BS Spurious emissions limits for BS in geographic coverage area of GSM 900 MS receiver**

Band	Maximum Level	Measurement Bandwidth	Note
921 - 960 MHz	-57 dBm	100 kHz	

#### 6.6.3.3.2 Co-located base stations

This requirement may be applied for the protection of GSM 900 BTS receivers when GSM 900 BTS and UTRA BS are co-located.

##### 6.6.3.3.2.1 Minimum Requirement

The power of any spurious emission shall not exceed:

**Table 6.12: BS Spurious emissions limits for protection of the GSM 900 BTS receiver**

Band	Maximum Level	Measurement Bandwidth	Note
876-915 MHz	-98 dBm	100 kHz	

### 6.6.3.4 Co-existence with DCS 1800

#### 6.6.3.4.1 Operation in the same geographic area

This requirement may be applied for the protection of DCS 1800 MS in geographic areas in which both DCS 1800 and UTRA are deployed.

##### 6.6.3.4.1.1 Minimum Requirement

The power of any spurious emission shall not exceed:

**Table 6.13: BS Spurious emissions limits for BS in geographic coverage area of DCS 1800 MS receiver**

Band	Maximum Level	Measurement Bandwidth	Note
1805 - 1880 MHz	-47 dBm	100 kHz	

#### 6.6.3.4.2 Co-located base stations

This requirement may be applied for the protection of DCS 1800 BTS receivers when DCS 1800 BTS and UTRA BS are co-located.

#### 6.6.3.4.2.1 Minimum Requirement

The power of any spurious emission shall not exceed:

**Table 6.14: BS Spurious emissions limits for BS co-located with DCS 1800 BTS**

Band	Maximum Level	Measurement Bandwidth	Note
1710 - 1785 MHz	-98 dBm	100 kHz	

#### 6.6.3.5 Co-existence with PHS

This requirement may be applied for the protection of PHS in geographic areas in which both PHS and UTRA are deployed.

##### 6.6.3.5.1 Minimum Requirement

The power of any spurious emission shall not exceed:

**Table 6.15: BS Spurious emissions limits for BS in geographic coverage area of PHS**

Band	Maximum Level	Measurement Bandwidth	Note
1893.5 - 1919.6 MHz	-41 dBm	300 kHz	

#### 6.6.3.6 Co-existence with services in adjacent frequency bands

This requirement may be applied for the protection in bands adjacent to 2110-2170 MHz, as defined in sub-clause 5.2(a) and 1930-1990 MHz, as defined in sub-clause 5.2(b) in geographic areas in which both an adjacent band service and UTRA are deployed.

##### 6.6.3.6.1 Minimum requirement

The power of any spurious emission shall not exceed:

**Table 6.16: BS spurious emissions limits for protection of adjacent band services**

Band (f)	Maximum Level	Measurement Bandwidth	Note
2100-2105 MHz For operation in frequency bands as defined in sub-clause 5.2(a)	$-30 + 3.4 \cdot (f - 2100 \text{ MHz})$ dBm	1 MHz	
2175-2180 MHz For operation in frequency bands as defined in sub-clause 5.2(a)	$-30 + 3.4 \cdot (2180 \text{ MHz} - f)$ dBm	1 MHz	
1920-1925 MHz For operation in frequency bands as defined in sub-clause 5.2(b)	$-30 + 3.4 \cdot (f - 1920 \text{ MHz})$ dBm	1 MHz	
1995-2000 MHz For operation in frequency bands as defined in sub-clause 5.2(b)	$-30 + 3.4 \cdot (2000 \text{ MHz} - f)$ dBm	1 MHz	

#### 6.6.3.7 Co-existence with UTRA-TDD

##### 6.6.3.7.1 Operation in the same geographic area

This requirement may be applied to geographic areas in which both UTRA-TDD and UTRA-FDD are deployed.

#### 6.6.3.7.1.1 Minimum Requirement

The power of any spurious emission shall not exceed:

**Table 6.17: BS Spurious emissions limits for BS in geographic coverage area of UTRA-TDD**

Band	Maximum Level	Measurement Bandwidth	Note
1900 - 1920 MHz	-52 dBm	1 MHz	
2010 - 2025 MHz	-52 dBm	1 MHz	

#### 6.6.3.7.2 Co-located base stations

This requirement may be applied for the protection of UTRA-TDD BS receivers when UTRA-TDD BS and UTRA FDD BS are co-located.

##### 6.6.3.7.2.1 Minimum Requirement

The power of any spurious emission shall not exceed:

**Table 6.18: BS Spurious emissions limits for BS co-located with UTRA-TDD**

Band	Maximum Level	Measurement Bandwidth	Note
1900 - 1920 MHz	-86 dBm	1 MHz	
2010 - 2025 MHz	-86 dBm	1 MHz	

## 6.7 Transmit intermodulation

The transmit intermodulation performance is a measure of the capability of the transmitter to inhibit the generation of signals in its non linear elements caused by presence of the wanted signal and an interfering signal reaching the transmitter via the antenna.

The transmit intermodulation level is the power of the intermodulation products when a WCDMA modulated interference signal is injected into the antenna connector at a level of 30 dB lower than that of the subject signal. The frequency of the interference signal shall be  $\pm 5$  MHz,  $\pm 10$  MHz and  $\pm 15$  MHz offset from the subject signal.

### 6.7.1 Minimum requirement

The transmit intermodulation level shall not exceed the out of band emission or the spurious emission requirements of section 6.6.2 and 6.6.3.

## 6.8 Transmit modulation

Transmit modulation is specified in three parts, Frequency Error, Error Vector Magnitude and Peak Code Domain Error. These specifications are made with reference to a theoretical modulated waveform.

The theoretical modulated waveform is created by modulating a carrier at the assigned carrier frequency using the same data as was used to generate the measured waveform. The chip modulation rate for the theoretical waveform shall be exactly 3.84 Mcps. The code powers of the theoretical waveform shall be the same as the measured waveform, rather than the nominal code powers used to generate the test signal.

### 6.8.1 Transmit pulse shape filter

The transmit pulse-shaping filter is a root-raised cosine (RRC) with roll-off  $\alpha = 0.22$  in the frequency domain. The impulse response of the chip impulse filter  $RC_0(t)$  is

$$RC_0(t) = \frac{\sin\left(\pi \frac{t}{T_c}(1-\alpha)\right) + 4\alpha \frac{t}{T_c} \cos\left(\pi \frac{t}{T_c}(1+\alpha)\right)}{\pi \frac{t}{T_c} \left(1 - \left(4\alpha \frac{t}{T_c}\right)^2\right)}$$

Where the roll-off factor  $\alpha = 0.22$  and the chip duration:

$$T_c = \frac{1}{\text{chiprate}} \approx 0.26042 \mu\text{s}$$

## 6.8.2 Error Vector Magnitude

The Error Vector Magnitude is a measure of the difference between the reference waveform and the measured waveform. This difference is called the error vector. Both waveforms pass through a matched Root Raised Cosine filter with bandwidth 3.84 MHz and roll-off  $\alpha = 0.22$ . Both waveforms are then further modified by selecting the frequency, absolute phase, absolute amplitude and chip clock timing so as to minimise the error vector. The EVM result is defined as the square root of the ratio of the mean error vector power to the mean reference power expressed as a %. The measurement interval is one timeslot as defined by the C-PICH (when present) otherwise the measurement interval is one timeslot starting with the beginning of the SCH. The requirement is valid over the total power dynamic range as specified in subclause 6.4.3.

### 6.8.2.1 Minimum requirement

The Error Vector Magnitude shall not be worse than 17.5 %.

## 6.8.3 Peak code Domain error

The Peak Code Domain Error is computed by projecting the power of the error vector (as defined in 6.8.2) onto the code domain at a specified spreading factor. The Code Domain Error for every code in the domain is defined as the ratio of the mean power of the projection onto that code, to the mean power of the composite reference waveform. This ratio is expressed in dB. The Peak Code Domain Error is defined as the maximum value for the Code Domain Error for all codes. The measurement interval is one timeslot as defined by the C-PICH (when present) otherwise the measurement interval is one timeslot starting with the beginning of the SCH. The requirement is valid over the total power dynamic range as specified in subclause 6.4.3.

### 6.8.3.1 Minimum requirement

The peak code domain error shall not exceed -33 dB at spreading factor 256.

---

# 7 Receiver characteristics

## 7.1 General

The requirements in Section 7 assume that the receiver is not equipped with diversity. For receivers with diversity, the requirements apply to each antenna connector separately, with the other one(s) terminated or disabled. The requirements are otherwise unchanged.

Unless otherwise stated, the receiver characteristics are specified at the BS antenna connector (test port A) with a full complement of transceivers for the configuration in normal operating conditions. If any external apparatus such as a RX amplifier, a diplexer, a filter or the combination of such devices is used, requirements apply at the far end antenna connector (port B).

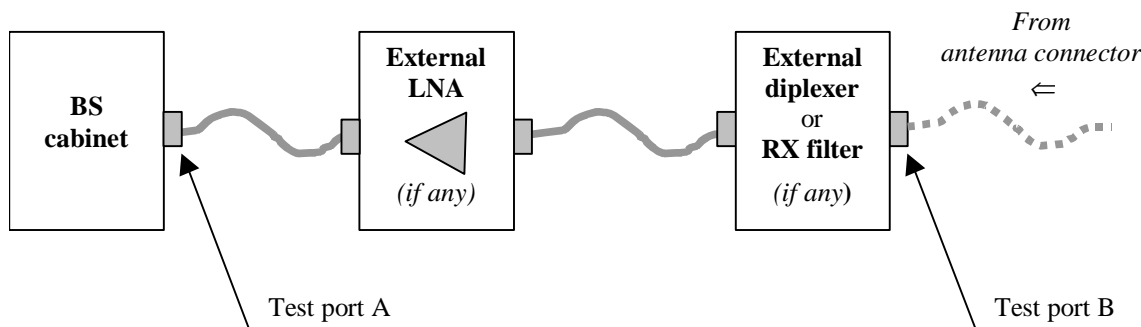

Figure 7.1: Receiver test ports

## 7.2 Reference sensitivity level

The reference sensitivity is the minimum receiver input power measured at the antenna connector at which the Bit Error Ratio (BER) does not exceed the specific value indicated in section 7.2.1.

### 7.2.1 Minimum requirement

For the measurement channel specified in Annex A, the reference sensitivity level and performance of the BS shall be as specified in Table 7.1.

Table 7.1: BS reference sensitivity levels

Measurement channel	BS reference sensitivity level (dBm)	BER
12.2 kbps	-121 dBm	BER shall not exceed 0.001

### 7.2.2 Maximum Frequency Deviation for Receiver Performance

The need for such a requirement is for further study.

## 7.3 Dynamic range

Receiver dynamic range is the receiver ability to handle a rise of interference in the reception frequency channel. The receiver shall fulfil a specified BER requirement for a specified sensitivity degradation of the wanted signal in the presence of an interfering AWGN signal in the same reception frequency channel.

### 7.3.1 Minimum requirement

The BER shall not exceed 0.001 for the parameters specified in Table 7.2.

Table 7.2 : Dynamic range

Parameter	Level	Unit
Data rate	12.2	kbps
Wanted signal	-91	dBm
Interfering AWGN signal	-73	dBm/3.84 MHz

## 7.4 Adjacent Channel Selectivity (ACS)

Adjacent channel selectivity (ACS) is a measure of the receiver ability to receive a wanted signal at its assigned channel frequency in the presence of an adjacent channel signal at a given frequency offset from the center frequency of the assigned channel. ACS is the ratio of the receiver filter attenuation on the assigned channel frequency to the receiver filter attenuation on the adjacent channel(s).

### 7.4.1 Minimum requirement

The BER shall not exceed 0.001 for the parameters specified in Table 7.3.

**Table 7.3 : Adjacent channel selectivity**

Parameter	Level	Unit
Data rate	12.2	kbps
Wanted signal	-115	dBm
Interfering signal	-52	dBm
F <sub>w</sub> (Modulated)	5	MHz

## 7.5 Blocking characteristics

The blocking characteristics is a measure of the receiver ability to receive a wanted signal at its assigned channel frequency in the presence of an unwanted interferer on frequencies other than those of the adjacent channels. The blocking performance shall apply at all frequencies as specified in the tables 7.4 to 7.5B below, using a 1 MHz step size.

### 7.5.1 Minimum requirement

The static reference performance as specified in clause 7.2.1 should be met with a wanted and an interfering signal coupled to BS antenna input using the following parameters.

**Table 7.4 : Blocking performance requirement for operation in frequency bands in sub-clause 5.2(a)**

Center Frequency of Interfering Signal	Interfering Signal Level	Wanted Signal Level	Minimum Offset of Interfering Signal	Type of Interfering Signal
1920 - 1980 MHz	-40 dBm	-115 dBm	10 MHz	WCDMA signal with one code
1900 - 1920 MHz 1980 - 2000 MHz	-40 dBm	-115 dBm	10 MHz	WCDMA signal with one code
1 MHz -1900 MHz, and 2000 MHz - 12750 MHz	-15 dBm	-115 dBm	—	CW carrier

**Table 7.5: Blocking performance requirement for operation in frequency bands in sub-clause 5.2(b)**

Center Frequency of Interfering Signal	Interfering Signal Level	Wanted Signal Level	Minimum Offset of Interfering Signal	Type of Interfering Signal
1850 - 1910 MHz	-40 dBm	-115 dBm	10 MHz	WCDMA signal with one code
1830 - 1850 MHz 1910 - 1930 MHz	-40 dBm	-115 dBm	10 MHz	WCDMA signal with one code
1 MHz - 1830 MHz 1930 MHz - 12750 MHz	-15 dBm	-115 dBm	—	CW carrier



## 7.5.2 Minimum Requirement – Co-location with GSM900 and/or DCS 1800

This requirement may be applied for the protection of FDD BS receivers when GSM900 and/or DCS1800 BTS are co-located with UTRA BS.

The static reference performance as specified in clause 7.2.1 shall be met with a wanted and an interfering signal coupled to BS antenna input using the following parameters.

**Table 7.5A: Blocking performance requirement for operation in frequency bands in sub-clause 5.2(a) when co-located with GSM900**

Center Frequency of Interfering Signal	Interfering Signal Level	Wanted Signal Level	Minimum Offset of Interfering Signal	Type of Interfering Signal
1920 - 1980 MHz	-40 dBm	-115 dBm	10 MHz	WCDMA signal with one code
1900 - 1920 MHz 1980 - 2000 MHz	-40 dBm	-115 dBm	10 MHz	WCDMA signal with one code
1 – 925 MHz and 960 - 1900 MHz, and 2000 MHz - 12750 MHz	-15 dBm	-115 dBm	—	CW carrier
925 -960 MHz	+16 dBm	-115 dBm	—	CW carrier

**Table 7.5B: Blocking performance requirement for operation in frequency bands in sub-clause 5.2(a) when co-located with DCS1800**

Center Frequency of Interfering Signal	Interfering Signal Level	Wanted Signal Level	Minimum Offset of Interfering Signal	Type of Interfering Signal
1920 - 1980 MHz	-40 dBm	-115 dBm	10 MHz	WCDMA signal with one code
1900 - 1920 MHz 1980 - 2000 MHz	-40 dBm	-115 dBm	10 MHz	WCDMA signal with one code
1 – 1805 MHz and 1880 - 1900 MHz, and 2000 MHz – 12750 MHz	-15 dBm	-115 dBm	—	CW carrier
1805 – 1880 MHz	+16 dBm	-115 dBm	—	CW carrier

## 7.6 Intermodulation characteristics

Third and higher order mixing of the two interfering RF signals can produce an interfering signal in the band of the desired channel. Intermodulation response rejection is a measure of the capability of the receiver to receive a wanted signal on its assigned channel frequency in the presence of two or more interfering signals which have a specific frequency relationship to the wanted signal.

### 7.6.1 Minimum requirement

The static reference performance as specified in clause 7.2.1 should be met when the following signals are coupled to BS antenna input:

- A wanted signal at the assigned channel frequency with a signal level of -115 dBm.
- Two interfering signals with the following parameters.

**Table 7.6 : Intermodulation performance requirement**

Interfering Signal Level	Offset	Type of Interfering Signal
- 48 dBm	10 MHz	CW signal
- 48 dBm	20 MHz	WCDMA signal with one code

## 7.7 Spurious emissions

The spurious emissions power is the power of emissions generated or amplified in a receiver that appear at the BS receiver antenna connector. The requirements apply to all BS with separate RX and TX antenna port. The test shall be performed when both TX and RX are on with the TX port terminated.

For all BS with common RX and TX antenna port the transmitter spurious emission as specified in section 6.6.3 is valid.

### 7.7.1 Minimum requirement

The power of any spurious emission shall not exceed:

**Table 7.7: Spurious emission minimum requirement**

Band	Maximum level	Measurement Bandwidth	Note
1900 - 1980 MHz and 2010 - 2025 MHz	-78 dBm	3.84 MHz	
9 kHz - 1 GHz	-57 dBm	100 kHz	
1 GHz - 12.75 GHz	-47 dBm	1 MHz	With the exception of frequencies between 12.5 MHz below the first carrier frequency and 12.5 MHz above the last carrier frequency used by the BS.

## 8 Performance requirement

### 8.1 General

Performance requirements for the BS are specified for the measurement channels defined in Annex A and the propagation conditions in Annex B. The requirements only apply to those measurement channels that are supported by the base station.

The requirements only apply to a base station with dual receiver antenna diversity. The required  $E_b/N_0$  shall be applied separately at each antenna port.

**Table 8.1: Summary of Base Station performance targets**

Physical channel	Measurement channel	Static	Multi-path Case 1	Multi-path Case 2	Multi-path Case 3	Moving	Birth / Death
		Performance metric					
DCH	12.2 kbps	$BLER < 10^{-2}$	$BLER < 10^{-2}$	$BLER < 10^{-2}$	$BLER < 10^{-2}$	$BLER <$	$BLER <$
	64 kbps	$BLER < 10^{-1}, 10^{-2}$	$BLER < 10^{-1}, 10^{-2}$	$BLER < 10^{-1}, 10^{-2}$	$BLER < 10^{-1}, 10^{-2}, 10^{-3}$	$BLER <$	$BLER <$
	144 kbps	$BLER < 10^{-1}, 10^{-2}$	$BLER < 10^{-1}, 10^{-2}$	$BLER < 10^{-1}, 10^{-2}$	$BLER < 10^{-1}, 10^{-2}, 10^{-3}$	-	-
	384 kbps	$BLER < 10^{-1}, 10^{-2}$	$BLER < 10^{-1}, 10^{-2}$	$BLER < 10^{-1}, 10^{-2}$	$BLER < 10^{-1}, 10^{-2}, 10^{-3}$	-	-

## 8.2 Demodulation in static propagation conditions

### 8.2.1 Demodulation of DCH

The performance requirement of DCH in static propagation conditions is determined by the maximum Block Error Ratio (BLER) allowed when the receiver input signal is at a specified  $E_b/N_0$  limit. The BLER is calculated for each of the measurement channels supported by the base station.

#### 8.2.1.1 Minimum requirement

The BLER should not exceed the limit for the  $E_b/N_0$  specified in Table 8.2.

**Table 8.2: Performance requirements in AWGN channel**

Measurement channel	Received $E_b/N_0$	Required BLER
12.2 kbps	n.a.	$< 10^{-1}$
	5.1 dB	$< 10^{-2}$
64 kbps	1.5 dB	$< 10^{-1}$
	1.7 dB	$< 10^{-2}$
144 kbps	0.8 dB	$< 10^{-1}$
	0.9 dB	$< 10^{-2}$
384 kbps	0.9 dB	$< 10^{-1}$
	1.0 dB	$< 10^{-2}$

## 8.3 Demodulation of DCH in multipath fading conditions

### 8.3.1 Multipath fading Case 1

The performance requirement of DCH in multipath fading Case 1 is determined by the maximum Block Error Ratio (BLER) allowed when the receiver input signal is at a specified  $E_b/N_0$  limit. The BLER is calculated for each of the measurement channels supported by the base station.

#### 8.3.1.1 Minimum requirement

The BLER should not exceed the limit for the  $E_b/N_0$  specified in Table 8.3.

**Table 8.3: Performance requirements in multipath Case 1 channel**

Measurement channel	Received $E_b/N_0$	Required BLER
12.2 kbps	n.a.	$< 10^{-1}$
	11.9 dB	$< 10^{-2}$
64 kbps	6.2 dB	$< 10^{-1}$
	9.2 dB	$< 10^{-2}$
144 kbps	5.4 dB	$< 10^{-1}$
	8.4 dB	$< 10^{-2}$
384 kbps	5.8 dB	$< 10^{-1}$
	8.8 dB	$< 10^{-2}$

### 8.3.2 Multipath fading Case 2

The performance requirement of DCH in multipath fading Case 2 is determined by the maximum Block Error Ratio (BLER) allowed when the receiver input signal is at a specified  $E_b/N_0$  limit. The BLER is calculated for each of the measurement channels supported by the base station.

### 8.3.2.1 Minimum requirement

The BLER should not exceed the limit for the  $E_b/N_0$  specified in Table 8.4.

**Table 8.4: Performance requirements in multipath Case 2 channel**

Measurement channel	Received $E_b/N_0$	Required BLER
12.2 kbps	n.a.	$< 10^{-1}$
	9.0 dB	$< 10^{-2}$
64 kbps	4.3 dB	$< 10^{-1}$
	6.4 dB	$< 10^{-2}$
144 kbps	3.7 dB	$< 10^{-1}$
	5.6 dB	$< 10^{-2}$
384 kbps	4.1 dB	$< 10^{-1}$
	6.1 dB	$< 10^{-2}$

### 8.3.3 Multipath fading Case 3

The performance requirement of DCH in multipath fading Case 3 is determined by the maximum Block Error Ratio (BLER) allowed when the receiver input signal is at a specified  $E_b/N_0$  limit. The BLER is calculated for each of the measurement channels supported by the base station.

#### 8.3.3.1 Minimum requirement

The BLER should not exceed the limit for the  $E_b/N_0$  specified in Table 8.5.

**Table 8.5: Performance requirements in multipath Case 3 channel**

Measurement channel	Received $E_b/N_0$	Required BLER
12.2 kbps	n.a.	$< 10^{-1}$
	7.2 dB	$< 10^{-2}$
	8.0 dB	$< 10^{-3}$
64 kbps	3.4 dB	$< 10^{-1}$
	3.8 dB	$< 10^{-2}$
	4.1 dB	$< 10^{-3}$
144 kbps	2.8 dB	$< 10^{-1}$
	3.2 dB	$< 10^{-2}$
	3.6 dB	$< 10^{-3}$
384 kbps	3.2 dB	$< 10^{-1}$
	3.6 dB	$< 10^{-2}$
	4.2 dB	$< 10^{-3}$

### 8.3.4 Multipath fading Case 4

The performance requirement of DCH in multipath fading Case 4 is determined by the maximum Block Error Ratio (BLER) allowed when the receiver input signal is at a specified  $E_b/N_0$  limit. The BLER is calculated for each of the measurement channels supported by the base station.

#### 8.3.4.1 Minimum requirement

The BLER should not exceed the limit for the  $E_b/N_0$  specified in Table 8.5A.

**Table 8.5A: Performance requirements in multipath Case 4 channel**

Measurement channel	Received $E_b/N_0$	Required BLER
12.2 kbps	n.a.	$< 10^{-1}$
	10.2 dB	$< 10^{-2}$
	11.0 dB	$< 10^{-3}$
64 kbps	6.4 dB	$< 10^{-1}$
	6.8 dB	$< 10^{-2}$
	7.1 dB	$< 10^{-3}$
144 kbps	5.8 dB	$< 10^{-1}$
	6.2 dB	$< 10^{-2}$
	6.6 dB	$< 10^{-3}$
384 kbps	6.2 dB	$< 10^{-1}$
	6.6 dB	$< 10^{-2}$
	7.2 dB	$< 10^{-3}$

## 8.4 Demodulation of DCH in moving propagation conditions

The performance requirement of DCH in moving propagation conditions is determined by the maximum Block Error Ratio (BLER) allowed when the receiver input signal is at a specified  $E_b/N_0$  limit. The BLER is calculated for each of the measurement channels supported by the base station.

### 8.4.1 Minimum requirement

The BLER should not exceed the limit for the  $E_b/N_0$  specified in Table 8.6.

**Table 8.6: Performance requirements in moving channel**

Measurement channel	Received $E_b/N_0$	Required BLER
12.2 kbps	n.a.	$< 10^{-1}$
	5.7 dB	$< 10^{-2}$
64 kbps	2.1 dB	$< 10^{-1}$
	2.2 dB	$< 10^{-2}$

## 8.5 Demodulation of DCH in birth/death propagation conditions

The performance requirement of DCH in birth/death propagation conditions is determined by the maximum Block Error Ratio (BLER) allowed when the receiver input signal is at a specified  $E_b/N_0$  limit. The BLER is calculated for each of the measurement channels supported by the base station.

### 8.5.1 Minimum requirement

The BLER should not exceed the limit for the  $E_b/N_0$  specified in Table 8.7.

**Table 8.7: Performance requirements in birth/death channel**

Measurement channel	Received $E_b/N_0$	Required BLER
12.2 kbps	n.a.	$< 10^{-1}$
	7.7 dB	$< 10^{-2}$
64 kbps	4.1 dB	$< 10^{-1}$
	4.2 dB	$< 10^{-2}$

## 8.6 BS Functionality in Site Selection Diversity Transmission (SSDT) Mode

Site Selection Diversity Transmission (SSDT) is an optional feature of BS. This requirement for SSDT mode ensures that BS correctly reacts to Layer 1 feedback signalling messages from UE.

### 8.6.1 Minimum requirements

For the conditions specified, the BS shall transmit or not transmit the downlink DPDCH channel.

**Table 8.8: Parameters for SSDT mode test**

Parameter	Unit	Test 1	Test 2	Test 3	Test 4
Cell ID of BS under test	-	A	A	A	A
SSDT Quality threshold, $Q_{th}$ , set in BS	DB	-5			
Uplink: $\frac{DPCH\_E_c}{I_o}$	DB	$Q_{th} + 10$	$Q_{th} + 10$	$Q_{th} - 3$	$Q_{th} - 3$
Cell ID transmitted by UE	-	A	B	A	B
Transmission Of downlink DPCCH	-	Yes	Yes	Yes	Yes
Transmission Of downlink DPDCH	-	Yes	No	Yes	Yes

The above test should be for repeated for each of the three code sets “long”, “medium” and “short” Cell ID code sets. The UE emulator can check the power ratio of downlink DPDCH/DPCCH in order to confirm whether BS transmitted the DPDCH.

## 8.7 Performance requirement for RACH

Performance requirements for RACH consists of two parts: preamble detection and message demodulation. Requirements for these are in sections 8.7.1 and 8.7.2, respectively. Requirements are defined for two propagation conditions: static and fading case 3. The propagation conditions are defined in annexes B.1 and B.2.

### 8.7.1 Performance requirement for RACH preamble detection

Probability of false alarm,  $P_{fa}$  (=false detection of the preamble) when the preamble was not sent, shall be  $10^{-3}$  or less. The performance measure Required  $E_c/N_0$  at probability of detection,  $P_d$  of 0.99 and 0.999. Only 1 signature is used and it is known by the receiver. The requirement for preamble detection, when the preamble was sent is in table 8.9 and 8.10 for static and case 3 fading.

**Table 8.9: Requirements for  $E_c/N_0$  of  $P_d$  in static propagation condition**

	<b><math>P_d = 0.99</math></b>	<b><math>P_d = 0.999</math></b>
Required $E_c/N_0$	-20.5 dB	-20.1 dB

**Table 8.10: Requirements of  $E_c/N_0$  of  $P_d$  in case 3 fading**

	<b><math>P_d = 0.99</math></b>	<b><math>P_d = 0.999</math></b>
Required $E_c/N_0$	-16.6 dB	-14.4 dB

## 8.7.2 Demodulation of RACH message

The performance measure is required  $E_b/N_0$  for block error rate (BLER) of  $10^{-1}$  and  $10^{-2}$ . Both measurement channels have TTI=20 ms. Payloads are 168 and 360 bits. Channel coding is rate  $\frac{1}{2}$  convolutional coding.

### 8.7.2.1 Minimum requirements for Static Propagation Condition

**Table 8.11: Required  $E_b/N_0$  for static propagation**

	<b>TB size = 168 bits</b>		<b>TB size = 360 bits</b>	
	<b><math>BLER=10^{-1}</math></b>	<b><math>BLER=10^{-2}</math></b>	<b><math>BLER=10^{-1}</math></b>	<b><math>BLER=10^{-2}</math></b>
Required $E_b/N_0$	3.1 dB	5.0 dB	3.9 dB	4.8 dB

### 8.7.2.2 Minimum requirements for Multipath Fading Case 3

**Table 8.12: Required  $E_b/N_0$  for case 3 fading**

	<b>TB size = 168 bits</b>		<b>TB size = 360 bits</b>	
	<b><math>BLER=10^{-1}</math></b>	<b><math>BLER=10^{-2}</math></b>	<b><math>BLER=10^{-1}</math></b>	<b><math>BLER=10^{-2}</math></b>
Required $E_b/N_0$	7.4 dB	7.5 dB	7.3 dB	8.3 dB

## Annex A (normative): Measurement channels

### A.1 Summary of UL reference measurement channels

The parameters for the UL reference measurement channels are specified in Table A.1 and the channel coding is detailed in figure A.2 through A.6 respectively. Note that for all cases, one DPCCH shall be attached to DPDCH(s).

**Table A.1: Reference measurement channels for UL DCH**

Parameter		DCH for DTCH / DCH for DCCH					Unit
DPDCH	Information bit rate	12.2/2.4	64/2.4	144/2.4	384/2.4	2048/2.4	kbps
	Physical channel	60/15	240/15	480/15	960/15	960/15	kbps
	Spreading factor	64	16	8	4	4	
	Repetition rate	22/22	19/19	8/9	-18/-18	-1/-1	%
	Interleaving	20	40	40	40	80	ms
	Number of DPDCHs	1	1	1	1	6	
DPCCH	Dedicated pilot	6					bit/slot
	Power control	2					bit/slot
	TFCI	2					bit/slot
	Spreading factor	256					
Power ratio of DPCCH/DPDCH		-2.69	-5.46	-9.54	-9.54	-9.54	dB
Amplitude ratio of DPCCH/DPDCH		0.7333	0.5333	0.3333	0.3333	0.3333	



## A.2 UL reference measurement channel for 12.2 kbps

The parameters for the UL reference measurement channel for 12.2 kbps are specified in Table A.2 and the channel coding is detailed in Figure A.2.

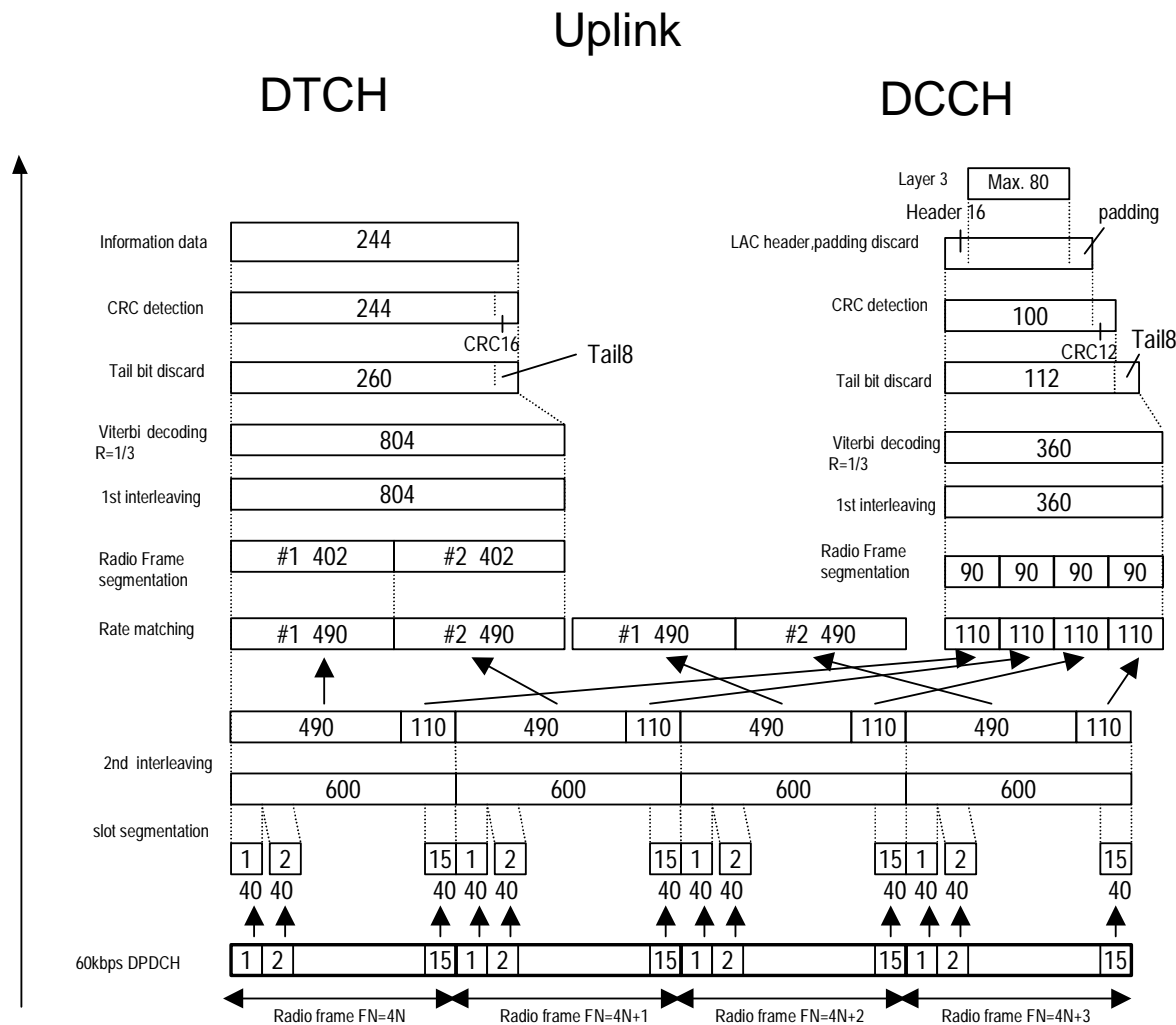

Figure A.2: Channel coding for the UL reference measurement channel (12.2 kbps)

Table A.2: UL reference measurement channel (12.2 kbps)

Parameter	Level	Unit
Information bit rate	12.2	kbps
DPCH	60	kbps
Power control	Off	
TFCI	On	
Repetition	22	%

# A.3 UL reference measurement channel for 64 kbps

The parameters for the UL reference measurement channel for 64 kbps are specified in Table A.3 and the channel coding is detailed in Figure A.3.

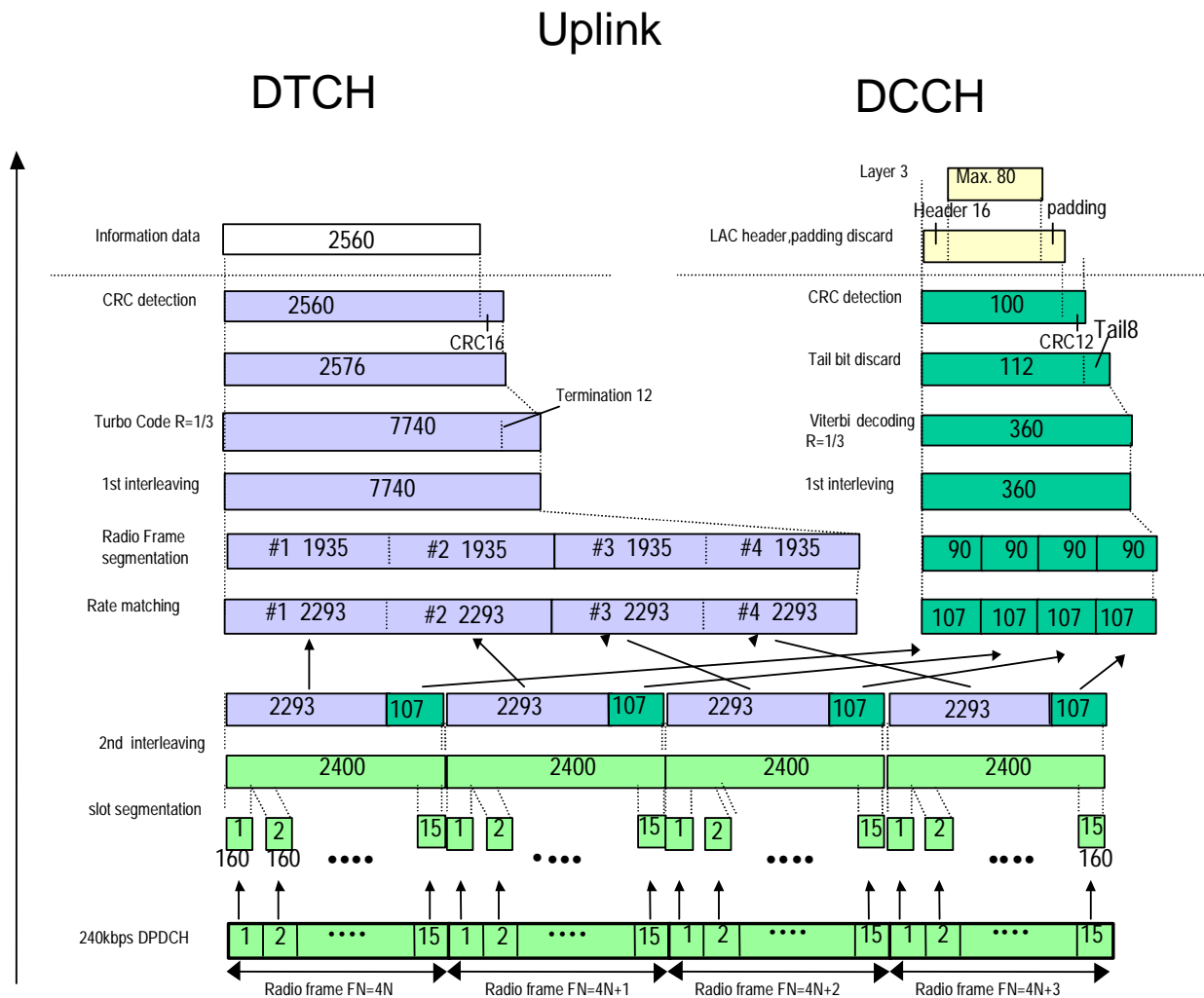

**Figure A.3: Channel coding for the UL reference measurement channel (64 kbps)**

**Table A.3: UL reference measurement channel (64kbps)**

Parameter	Level	Unit
Information bit rate	64	kbps
DPCH	240	kbps
Power control	Off	
TFCI	On	
Repetition	19	%

# A.4 UL reference measurement channel for 144 kbps

The parameters for the UL reference measurement channel for 144 kbps are specified in Table A.4 and the channel coding is detailed in Figure A.4.

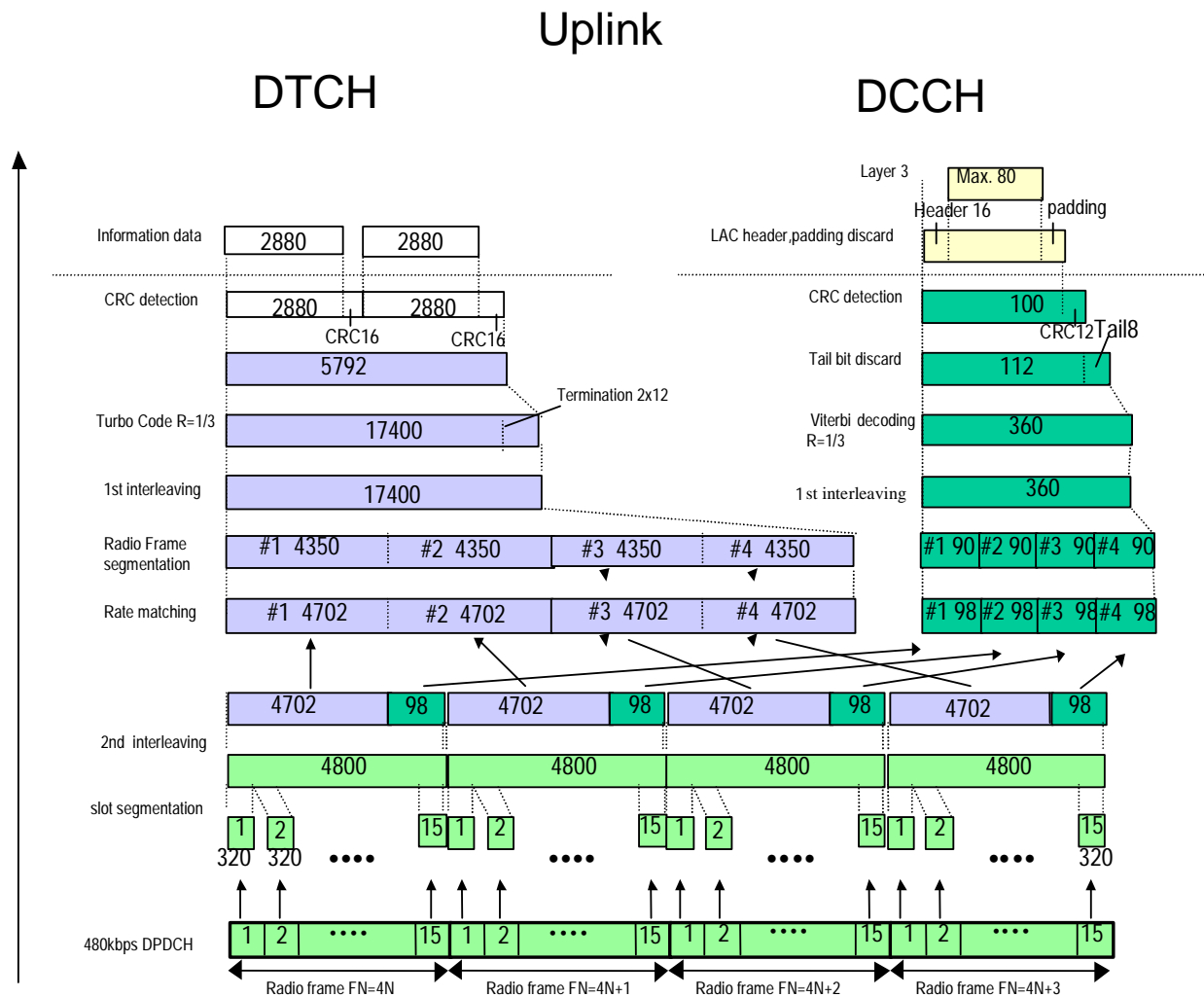

Figure A.4: Channel coding for the UL reference measurement channel (144 kbps)

Table A.4: UL reference measurement channel (144kbps)

Parameter	Level	Unit
Information bit rate	144	Kbps
DPCH	480	Kbps
Power control	Off	
TFCI	On	
Repetition	8	%

# A.5 UL reference measurement channel for 384 kbps

The parameters for the UL reference measurement channel for 384 kbps are specified in Table A.5 and the channel coding is detailed in Figure A.5.

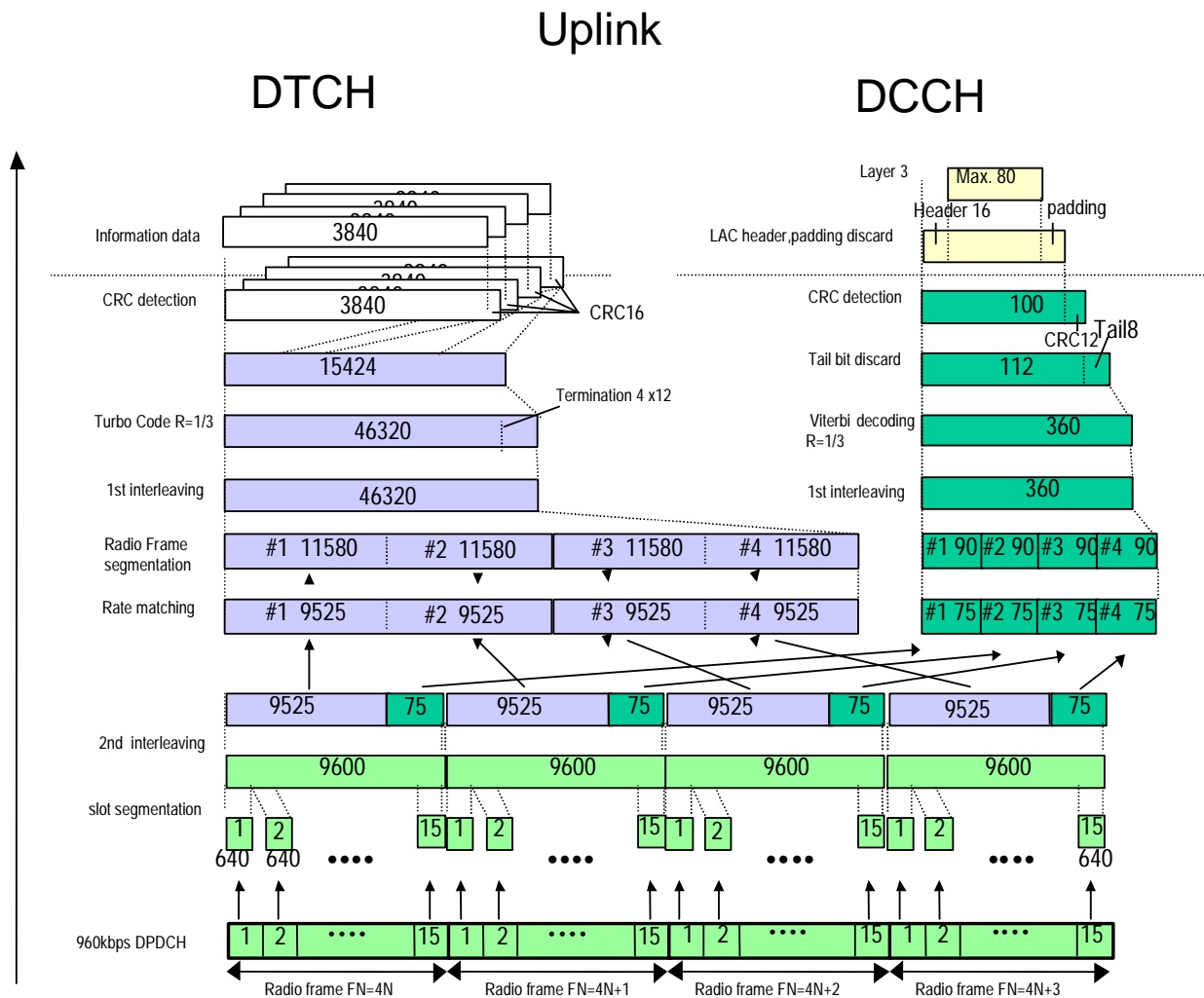

Figure A.5: Channel coding for the UL reference measurement channel (384 kbps)

Table A.5: UL reference measurement channel (384kbps)

Parameter	Level	Unit
Information bit rate	384	Kbps
DPCH	960	Kbps
Power control	Off	
TFCI	On	
Puncturing	18	%

# A.6 UL reference measurement channel for 2048 kbps

The parameters for the UL reference measurement channel for 2048 kbps are specified in Table A.6 and the channel coding is detailed in Figure A.6.

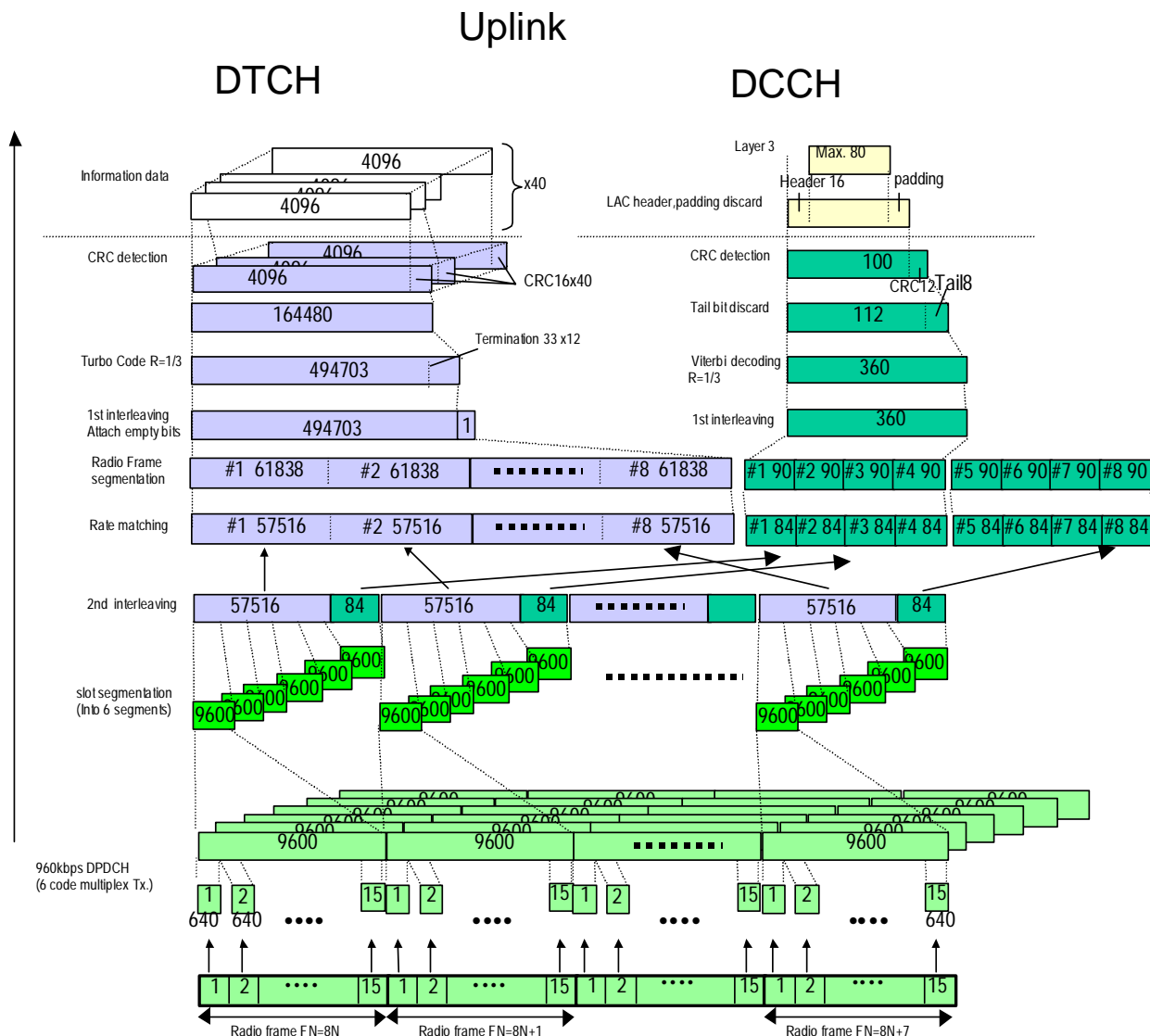

Figure A.6: Channel coding for the UL reference measurement channel (2048 kbps)

Table A.6: UL reference measurement channel (2048kbps)

Parameter	Level	Unit
Information bit rate	2048	Kbps
DPCH	960	Kbps
Power control	Off	
TFCI	On	
Puncturing	1	%

## Annex B (normative): Propagation conditions

### B.1 Static propagation condition

The propagation for the static performance measurement is an Additive White Gaussian Noise (AWGN) environment. No fading or multi-paths exist for this propagation model.

### B.2 Multi-path fading propagation conditions

Table B.1 shows propagation conditions that are used for the performance measurements in multi-path fading environment. All taps have classical Doppler spectrum.

**Table B.1: Propagation Conditions for Multi path Fading Environments**

Case 1, speed 3km/h		Case 2, speed 3 km/h		Case 3, 120 km/h		Case 4, 250 km/h	
Relative Delay [ns]	Average Power [dB]	Relative Delay [ns]	Average Power [dB]	Relative Delay [ns]	Average Power [dB]	Relative Delay [ns]	Average Power [dB]
0	0	0	0	0	0	0	0
976	-10	976	0	260	-3	260	-3
		20000	0	521	-6	521	-6
				781	-9	781	-9

### B.3 Moving propagation conditions

The dynamic propagation conditions for the test of the base band performance are non-fading channel models with two taps. The moving propagation condition has two tap, one static, Path0, and one moving, Path1. The time difference between the two paths is according Equation (B.1). The parameters for the equation are shown in Table B.2. The taps have equal strengths and equal phases.

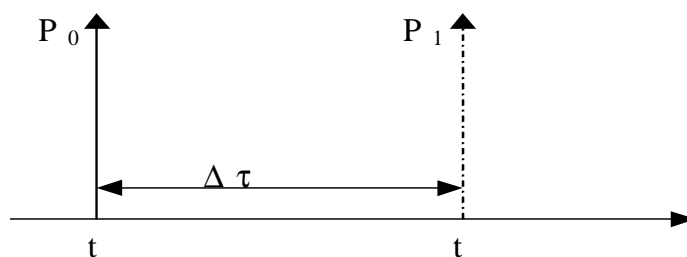

**Figure B.1: The moving propagation conditions**

$$\Delta\tau = B + \frac{A}{2}(1 + \sin(\Delta\omega \cdot t)) \quad (\text{B.1})$$

**Table B.2: Parameters for moving propagation**

A	5 μs
B	1 μs
Δω	40·10 <sup>-3</sup> s <sup>-1</sup>

## B.4 Birth-Death propagation conditions

The dynamic propagation conditions for the test of the baseband performance is a non-fading propagation channel with two taps. The moving propagation conditions has two taps, Path1 and Path2 which alternate between 'birth' and 'death'. The positions the paths appear are randomly selected with an equal probability rate and are shown in Figure B.2.

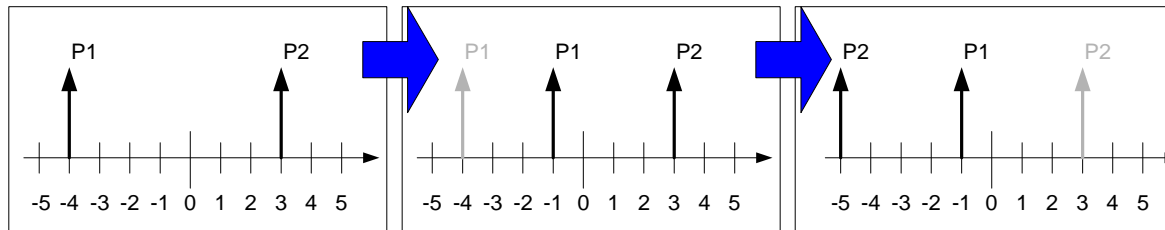

**Figure B.2: Birth death propagation sequence**

1. Two paths, Path1 and Path2 are randomly selected from the group  $[-5, -4, -3, -2, -1, 0, 1, 2, 3, 4, 5]$   $\mu\text{s}$ . The paths have equal magnitudes and equal phases.
2. After 191 ms, Path1 vanishes and reappears immediately at a new location randomly selected from the group  $[-5, -4, -3, -2, -1, 0, 1, 2, 3, 4, 5]$   $\mu\text{s}$  but excludes the point Path2. The magnitudes and the phases of the tap coefficients of Path 1 and Path 2 shall remain unaltered.
3. After an additional 191 ms, Path2 vanishes and reappears immediately at a new location randomly selected from the group  $[-5, -4, -3, -2, -1, 0, 1, 2, 3, 4, 5]$   $\mu\text{s}$  but excludes the point Path1. The magnitudes and the phases of the tap coefficients of Path 1 and Path 2 shall remain unaltered.
4. The sequence in 2) and 3) is repeated.

---

## Annex C (informative): Change history

<b>Document history</b>		
V3.0.0	October 1999	
V3.1.0	December 1999	CRs approved by TSG-RAN#6
V3.2.1	March 2000	CRs approved by TSG-RAN#7
V3.3.0	June 2000	CRs approved by TSG-RAN#8
V3.4.0	October 2000	CRs approved by TSG-RAN#9
V3.5.0	December 2000	CRs approved by TSG-RAN#10
V3.6.0	March 2001	CRs approved by TSG-RAN#11



## Annex D (informative): Change request history

**Table D.1: Inclusion of CRs approved by TSG-RAN#6.**

RAN Doc	Spec	CR	R	Ph	Subject	Cat	Curr	New
RP-99778	25.104	001		R99	Correction to Annex B.4 Birth-Death propagation conditions	F	3.0.0	3.1.0
RP-99778	25.104	002		R99	Base Station Modulation Code Domain Power	F	3.0.0	3.1.0
RP-99778	25.104	003		R99	Measurement channels for uplink	F	3.0.0	3.1.0
RP-99777	25.104	004		R99	Removal of Open Item List	D	3.0.0	3.1.0
RP-99778	25.104	005		R99	Clarification of ACLR requirement	F	3.0.0	3.1.0
RP-99778	25.104	006		R99	New Spurious Emission requirement for Category B	F	3.0.0	3.1.0
RP-99778	25.104	007		R99	Base Station Primary CPICH power accuracy	F	3.0.0	3.1.0
RP-99778	25.104	008		R99	Correction of Receiver sensitivity	F	3.0.0	3.1.0
RP-99778	25.104	010		R99	Correction of BS output power definition	F	3.0.0	3.1.0
RP-99778	25.104	011		R99	Clarification of power control requirements in TS 25.104	F	3.0.0	3.1.0
RP-99778	25.104	012		R99	Corrections for BS FDD Blocking Characteristics	F	3.0.0	3.1.0
RP-99778	25.104	013		R99	Output power accuracies in extreme conditions	F	3.0.0	3.1.0
RP-99778	25.104	014		R99	Clarification of Antenna Diversity receiver requirements	F	3.0.0	3.1.0
RP-99778	25.104	015		R99	Spurious Emission in 25.104	F	3.0.0	3.1.0
RP-99831	25.104	016	1	R99	Change of propagation conditions		3.0.0	3.1.0
RP-99778	25.104	017		R99	Clarification of the EVM requirement	F	3.0.0	3.1.0
RP-99778	25.104	018		R99	Introduction of requirement values in section 8	F	3.0.0	3.1.0
RP-99825	25.104	019	2	R99	Update of ITU Region 2 Specific Specifications and proposed universal channel numbering.	C	3.0.0	3.1.0
RP-99778	25.104	020		R99	Corrections for BS FDD RX spurious emission	F	3.0.0	3.1.0
RP-99778	25.104	021		R99	BS Spurious Emission Requirements for Co-Existence UTRA-FDD/ UTRA-TDD	B	3.0.0	3.1.0

**Table D.2: Inclusion of CRs approved by TSG-RAN#7.**

RAN Doc	Spec	CR	R	Ph	Subject	Cat	Curr	New
R4-000030	25.104	022		R99	Clarification of Receiver Dynamic Range requirement	F	3.1.0	3.2.0
R4-000096	25.104	023		R99	Change of propagation conditions for Case 2	F	3.1.0	3.2.0
R4-000019	25.104	024		R99	Removal of chapter 6.6.2.3 in 25.104	F	3.1.0	3.2.0
R4-000086	25.104	025		R99	Editorial changes to 25.104	D	3.1.0	3.2.0
R4-000101	25.104	026		R99	Corrections of spurious emissions aligning to GSM for UTRA: FDD BS	F	3.1.0	3.2.0
R4-000299	25.104	027	1	R99	Regional requirements in TS 25.104	D	3.1.0	3.2.0
R4-000137	25.104	028		R99	Specifications applicable in case of use of RF devices external to the BS	F	3.1.0	3.2.0
R4-000186	25.104	029		R99	Clarification for maximum output power and rated output power	F	3.1.0	3.2.0
R4-000215	25.104	030		R99	UL Performance requirement in multipath case 3	F	3.1.0	3.2.0
R4-000258	25.104	031		R99	ACLR	D	3.1.0	3.2.0
R4-000254	25.104	032		R99	Spectrum emission mask	F	3.1.0	3.2.0
R4-000130	25.104	033		R99	Rx spurious emissions measurement bandwidth	F	3.1.0	3.2.0
R4-000245	25.104	034		R99	Clarification for Peak code domain error	D	3.1.0	3.2.0
R4-000026	25.104	035		R99	Corrections for BS FDD Modulation Accuracy	F	3.1.0	3.2.0
R4-000291	25.104	036		R99	Modification to the handling of measurement equipment uncertainty	F	3.1.0	3.2.0
R4-000181	25.104	037		R99	Update to downlink test models	D	3.1.0	3.2.0
R4-000163	25.104	038		R99	Birth-Death tap delays	F	3.1.0	3.2.0

**Table D.3: Inclusion of CRs approved by TSG-RAN#8.**

RAN Doc	Spec	CR	R	Ph	Subject	Cat	Curr	New
RP-000206	25.104	040		R99	Correction of frequency numbering scheme	F	3.2.0	3.3.0
RP-000206	25.104	041		R99	Add requirements on SSDT from 5.1.1.8.	D	3.2.0	3.3.0
RP-000206	25.104	042		R99	Correction to Emission mask	F	3.2.0	3.3.0
RP-000206	25.104	043		R99	Clarification of the specification on Peak Code Domain Error (PCDE)	F	3.2.0	3.3.0
RP-000206	25.104	044		R99	Editorial changes, including definitions and abbreviations	D	3.2.0	3.3.0
RP-000206	25.104	045		R99	Reference Measurement Channels	F	3.2.0	3.3.0
RP-000206	25.104	046		R99	Editorial corrections on moving propagation conditions	F	3.2.0	3.3.0
RP-000206	25.104	047		R99	Conformance values for dynamic propagation conditions	F	3.2.0	3.3.0
RP-000206	25.104	048		R99	Alignment of measurement descriptions between 25.141 and 25.101	F	3.2.0	3.3.0

**Table D.4: Inclusion of CRs approved by TSG-RAN#9.**

RAN Doc	Spec	CR	R	Ph	Subject	Cat	Curr	New
RP-000396	25.104	49		R99	Correction to 25.104 ch. 6.6.3.6	F	3.3.0	3.4.0
RP-000396	25.104	50		R99	Corrections to spectrum mask	F	3.3.0	3.4.0
RP-000396	25.104	51		R99	Handling of measurement uncertainties in Base station conformance testing (FDD)	F	3.3.0	3.4.0
RP-000396	25.104	52		R99	Tap magnitudes and phases for Birth-Death propagation conditions	F	3.3.0	3.4.0

**Table D.5: CRs approved by TSG RAN #10**

RAN Doc	Spec	CR	R	Ph	Subject	Cat	Curr	New
R4-000982	25.104	53		R99	Correction for 25.104 concerning the channel number calculation.	F	3.4.0	3.5.0
R4-000963	25.104	54		R99	Editorial correction to uplink reference channel for 2048kbps	F	3.4.0	3.5.0

**Table D.6: Release 1999 CRs approved by TSG RAN#11**

RAN Doc	Spec	CR	R	Ph	Subject	Cat	Curr	New
RP-010087	25.104	55		R99	CR to 25.104 for Test Tolerances	F	3.5.0	3.6.0
RP-010087	25.104	56		R99	Correction of reference to SM.329-8 in TS 25.104	F	3.5.0	3.6.0
RP-010087	25.104	57		R99	Receiver Blocking requirement for co-existence with GSM/DCS and co-located base stations - revised.	F	3.5.0	3.6.0
RP-010087	25.104	58		R99	UL Performance requirement in fast fading	F	3.5.0	3.6.0
RP-010087	25.104	59		R99	Performance requirement for 250km/h	F	3.5.0	3.6.0
RP-010087	25.104	60		R99	Definition of EVM / PCDE measurement period	F	3.5.0	3.6.0
RP-010087	25.104	61		R99	Inclusion of environmental requirements	F	3.5.0	3.6.0

**Table D.6: Release 1999 CRs approved by TSG RAN#11**

RAN Doc	Spec	CR	R	Ph	Subject	Cat	Curr	New
RP-010100	25.104	63		R4	RACH implementation requirements	B	3.6.0	4.0.0

---

## History

<b>Document history</b>		
V4.0.0	March 2001	Publication