

# ETSI TS 124 606 V15.0.0 (2018-07)



**Digital cellular telecommunications system (Phase 2+) (GSM);  
Universal Mobile Telecommunications System (UMTS);  
LTE;  
Message Waiting Indication (MWI) using IP Multimedia (IM)  
Core Network (CN) subsystem;  
Protocol specification  
(3GPP TS 24.606 version 15.0.0 Release 15)**



---

**Reference**

RTS/TSGC-0124606vf00

---

**Keywords**

GSM,LTE,UMTS

**ETSI**

650 Route des Lucioles  
F-06921 Sophia Antipolis Cedex - FRANCE

Tel.: +33 4 92 94 42 00 Fax: +33 4 93 65 47 16

Siret N° 348 623 562 00017 - NAF 742 C  
Association à but non lucratif enregistrée à la  
Sous-Préfecture de Grasse (06) N° 7803/88

---

**Important notice**

The present document can be downloaded from:

<http://www.etsi.org/standards-search>

The present document may be made available in electronic versions and/or in print. The content of any electronic and/or print versions of the present document shall not be modified without the prior written authorization of ETSI. In case of any existing or perceived difference in contents between such versions and/or in print, the only prevailing document is the print of the Portable Document Format (PDF) version kept on a specific network drive within ETSI Secretariat.

Users of the present document should be aware that the document may be subject to revision or change of status.

Information on the current status of this and other ETSI documents is available at

<https://portal.etsi.org/TB/ETSIDeliverableStatus.aspx>

If you find errors in the present document, please send your comment to one of the following services:

<https://portal.etsi.org/People/CommiteeSupportStaff.aspx>

---

**Copyright Notification**

No part may be reproduced or utilized in any form or by any means, electronic or mechanical, including photocopying and microfilm except as authorized by written permission of ETSI.

The content of the PDF version shall not be modified without the written authorization of ETSI.

The copyright and the foregoing restriction extend to reproduction in all media.

© ETSI 2018.

All rights reserved.

**DECT™**, **PLUGTESTS™**, **UMTS™** and the ETSI logo are trademarks of ETSI registered for the benefit of its Members.

**3GPP™** and **LTE™** are trademarks of ETSI registered for the benefit of its Members and of the 3GPP Organizational Partners.

**oneM2M** logo is protected for the benefit of its Members.

**GSM®** and the GSM logo are trademarks registered and owned by the GSM Association.

---

# Intellectual Property Rights

## Essential patents

IPRs essential or potentially essential to normative deliverables may have been declared to ETSI. The information pertaining to these essential IPRs, if any, is publicly available for **ETSI members and non-members**, and can be found in ETSI SR 000 314: *"Intellectual Property Rights (IPRs); Essential, or potentially Essential, IPRs notified to ETSI in respect of ETSI standards"*, which is available from the ETSI Secretariat. Latest updates are available on the ETSI Web server (<https://ipr.etsi.org/>).

Pursuant to the ETSI IPR Policy, no investigation, including IPR searches, has been carried out by ETSI. No guarantee can be given as to the existence of other IPRs not referenced in ETSI SR 000 314 (or the updates on the ETSI Web server) which are, or may be, or may become, essential to the present document.

## Trademarks

The present document may include trademarks and/or tradenames which are asserted and/or registered by their owners. ETSI claims no ownership of these except for any which are indicated as being the property of ETSI, and conveys no right to use or reproduce any trademark and/or tradename. Mention of those trademarks in the present document does not constitute an endorsement by ETSI of products, services or organizations associated with those trademarks.

---

# Foreword

This Technical Specification (TS) has been produced by ETSI 3rd Generation Partnership Project (3GPP).

The present document may refer to technical specifications or reports using their 3GPP identities, UMTS identities or GSM identities. These should be interpreted as being references to the corresponding ETSI deliverables.

The cross reference between GSM, UMTS, 3GPP and ETSI identities can be found under <http://webapp.etsi.org/key/queryform.asp>.

---

# Modal verbs terminology

In the present document "**shall**", "**shall not**", "**should**", "**should not**", "**may**", "**need not**", "**will**", "**will not**", "**can**" and "**cannot**" are to be interpreted as described in clause 3.2 of the [ETSI Drafting Rules](#) (Verbal forms for the expression of provisions).

"**must**" and "**must not**" are **NOT** allowed in ETSI deliverables except when used in direct citation.

# Contents

Intellectual Property Rights .....	2
Foreword.....	2
Modal verbs terminology.....	2
Foreword.....	5
1 Scope .....	6
2 References .....	6
3 Definitions and abbreviations.....	7
3.1 Definitions .....	7
3.2 Abbreviations .....	7
4 Message Waiting Indication (MWI).....	8
4.1 Introduction .....	8
4.2 Description .....	8
4.2.1 General description .....	8
4.3 Functional entities .....	8
4.3.1 User Equipment (UE) .....	8
4.3.2 Application Server (AS) .....	8
4.4 Roles.....	8
4.4.1 MWI Subscriber User Agent (MSUA) .....	8
4.4.2 MWI Notifier User Agent (MNUA).....	8
4.4.3 Message Account (MA).....	8
4.4.3.0 General .....	8
4.4.3.1 Identification of the message account for the message deposit.....	9
4.4.3.2 Identification of the message account for the MWI subscription.....	9
4.5 Operational requirements .....	9
4.5.1 Provision/withdrawal .....	9
4.5.2 Requirements on the originating network side.....	9
4.5.3 Requirements in the network .....	9
4.5.4 Requirements on the terminating network side.....	9
4.6 Coding requirements .....	9
4.7 Signalling requirements.....	10
4.7.1 Activation/deactivation .....	10
4.7.1A Registration/erasure .....	10
4.7.1B Interrogation .....	10
4.7.2 Invocation and operation .....	10
4.7.2.1 Actions at the MSUA .....	10
4.7.2.2 Void.....	10
4.7.2.3 Void.....	10
4.7.2.4 Void.....	10
4.7.2.5 Actions at the MNUA .....	10
4.7.2.6 Void.....	11
4.7.2.7 Void.....	11
4.7.2.8 Void.....	11
4.7.2.9 Void.....	11
4.8 Interaction with other IMS capabilities .....	11
4.8.1 Void .....	11
4.8.2 Void .....	11
4.9 Interaction with other services.....	11
4.9.1 Communication Hold (HOLD).....	11
4.9.2 Terminating Identification Presentation (TIP).....	11
4.9.3 Terminating Identification Restriction (TIR).....	11
4.9.4 Originating Identification Presentation (OIP).....	11
4.9.5 Originating Identification Restriction (OIR).....	11
4.9.6 CONference calling (CONF) .....	11
4.9.7 Communication DIVersion services (CDIV).....	11

4.9.7.0	General .....	11
4.9.7.1	Communication Forwarding Unconditional (CFU) .....	11
4.9.7.2	Communication Forwarding Busy (CFB) .....	11
4.9.7.3	Communication Forwarding No Reply (CFNR) .....	12
4.9.7.4	Communication Forwarding on Not Logged-in (CFNL) .....	12
4.9.7.5	Communication Deflection (CD) .....	12
4.9.8	Malicious Call IDentification (MCID) .....	12
4.9.9	Explicit Communication Transfer (ECT) .....	12
4.9.10	Enhanced Calling Name (eCNAM) .....	12
4.10	Interactions with other networks .....	12
4.10.1	Void .....	12
4.10.2	Void .....	12
4.10.3	Void .....	12
4.11	Parameter values (timers) .....	12

**Annex A (informative): Example signalling flows of Message Waiting Indication (MWI) service operation .....13**

A.1	Scope of signalling flows .....	13
A.1.1	Introduction .....	13
A.1.1.1	General.....	13
A.1.1.2	Key required to interpret signalling flows .....	13
A.1.2	Signalling flows demonstrating how UE subscribes to message waiting indication event notification .....	13
A.1.2.1	Introduction.....	13
A.1.2.2	MWI Subscriber subscribing to the status of his message account, MWI AS is in the subscriber's network .....	13
A.1.2.3	Void .....	19
A.1.3	Signalling flows demonstrating how AS sends message waiting indication notification to the UE which does not implement RFC 3842 .....	19
A.1.3.1	Introduction.....	19
A.1.3.2	Registration signalling for MWI subscriber.....	19
A.1.3.3	AS notify subscriber when message account state change .....	22
A.1.4	Signalling flows demonstrating how a message is deposited into the subscribers message account .....	23
A.1.4.1	Introduction.....	23
A.1.4.2	Depositing a message into the subscriber's message account .....	23
A.1.4.2.1	Successful message deposit into the subscriber's message account .....	23

**Annex B (informative): Example of a filter criteria .....27**

**Annex C (informative): Void .....28**

**Annex D (informative): Change history .....29**

History .....	30
---------------	----

---

# Foreword

This Technical Specification has been produced by the 3<sup>rd</sup> Generation Partnership Project (3GPP).

The contents of the present document are subject to continuing work within the TSG and may change following formal TSG approval. Should the TSG modify the contents of the present document, it will be re-released by the TSG with an identifying change of release date and an increase in version number as follows:

Version x.y.z

where:

- x the first digit:
  - 1 presented to TSG for information;
  - 2 presented to TSG for approval;
  - 3 or greater indicates TSG approved document under change control.
- y the second digit is incremented for all changes of substance, i.e. technical enhancements, corrections, updates, etc.
- z the third digit is incremented when editorial only changes have been incorporated in the document.

---

# 1 Scope

The present document specifies the stage three Protocol Description of the Message Waiting Indication (MWI) service, based on stage one and two of the ISDN MWI supplementary services. It provides the protocol details in the IP Multimedia (IM) Core Network (CN) subsystem based on the Session Initiation Protocol (SIP) and the Session Description Protocol (SDP).

The present document is applicable to User Equipment (UE) and Application Servers (AS) which are intended to support the MWI supplementary service.

---

# 2 References

The following documents contain provisions which, through reference in this text, constitute provisions of the present document.

- References are either specific (identified by date of publication, edition number, version number, etc.) or non-specific.
- For a specific reference, subsequent revisions do not apply.
- For a non-specific reference, the latest version applies. In the case of a reference to a 3GPP document (including a GSM document), a non-specific reference implicitly refers to the latest version of that document *in the same Release as the present document*.

- [1] 3GPP TS 22.173: "IP Multimedia Core Network Subsystem (IMS) Multimedia Telephony Service and supplementary services; Stage 1".
- [2] 3GPP TS 24.229: "Internet Protocol (IP) multimedia call control protocol based on Session Initiation Protocol (SIP) and Session Description Protocol (SDP); Stage 3".
- [3] IETF RFC 3842: "A Message Summary and Message Waiting Indication Event Package for the Session Initiation Protocol (SIP)".
- [4] IETF RFC 6665: "SIP-Specific Event Notification".
- [5] IETF RFC 3458: "Message Context for Internet Mail".
- [6] IETF RFC 3938: "Video-Message Message-Context".
- [7] IETF RFC 2822: "Internet Message Format".
- [8] IETF RFC 2156: "MIXER (Mime Internet X.400 Enhanced Relay): Mapping between X.400 and RFC 822/MIME".
- [9] IETF RFC 3263: "Session Initiation Protocol (SIP): Locating SIP Servers".
- [10] 3GPP TS 22.101: "Service aspects; Service principles".
- [11] IETF RFC 3261: "SIP: Session Initiation Protocol".
- [12] 3GPP TS 24.228 Release 5: "Signalling flows for the IP multimedia call control based on Session Initiation Protocol (SIP) and Session Description Protocol (SDP); Stage 3".
- [13] 3GPP TS 23.003: "Numbering, addressing and identification".
- [14] Void
- [15] 3GPP TS 22.228: "Service requirements for the Internet Protocol (IP) multimedia core network subsystem (IMS); Stage 1".
- [16] IETF RFC 3428: "Session Initiation Protocol (SIP) Extension for Instant Messaging".

## 3 Definitions and abbreviations

### 3.1 Definitions

For the purposes of the present document, the terms and definitions given in 3GPP TS 22.173 [1], 3GPP TS 22.101 [10], 3GPP TS 22.228 [15], 3GPP TS 23.003 [13] and the following apply:

**correspondent:** person or entity that deposits messages in the subscriber's message account

NOTE: Correspondent and subscriber can be the same person or entity.

**Message Account (MA):** resource that retains multimedia messages (voice, video, fax, etc.) deposited by correspondents for the subscriber

**subscriber:** person or entity that receives status information about deposited messages

**supplementary service:** modifies or supplements a basic Telecommunication service

### 3.2 Abbreviations

For the purposes of the present document, the following abbreviations apply:

AS	Application Server
CD	Communication Deflection
CDIV	Communication DIVersion
CFB	Communication Forwarding Busy
CFNL	Communication Forwarding on Not Logged-in
CFNR	Communication Forwarding No Reply
CFU	Communication Forwarding Unconditional
CONF	CONFerence calling
CSCF	Call Session Control Function
ECT	Explicit Communication Transfer
HOLD	Communication Hold
I-CSCF	Interrogating - CSCF
IMS	IP Multimedia Subsystem
IP	Internet Protocol
ISDN	Integrated Service Data Network
MA	Message Account
MCID	Malicious Call IDentification
MIME	Multipurpose Internet Mail Extensions
MNUA	MWI Notifier User Agent
MSUA	MWI Subscriber User Agent
MWI	Message Waiting Indication
OIP	Originating Identification Presentation
OIR	Originating Identification Restriction
P-CSCF	Proxy - CSCF
PSI	Public Service Identity
PSTN	Public Switch Telephone Network
S-CSCF	Serving - CSCF
SDP	Session Description Protocol
SIP	Session Initiation Protocol
TIP	Terminating Identification Presentation
TIR	Terminating Identification Restriction
UA	User Agent
UE	User Equipment
URI	Universal Resource Identifier



---

## 4 Message Waiting Indication (MWI)

### 4.1 Introduction

The Message Waiting Indication (MWI) service enables the network, upon the request of a controlling user to indicate to the receiving user, that there is at least one message waiting.

### 4.2 Description

#### 4.2.1 General description

The MWI service enables the AS to indicate to the subscriber, that there is at least one message waiting.

The indication is delivered to the subscriber's UE after successful subscription to the Message Waiting Indication service as described in the present document.

Other modes of MWI service invocation are not applicable.

NOTE: Having received this indication, the subscriber user can subsequently access the message account, to have the deposited message delivered. The means by which the subscriber accesses and manages the message account are outside the scope of the present document.

### 4.3 Functional entities

#### 4.3.1 User Equipment (UE)

The UE shall implement the MWI Subscriber User Agent role as described in subclause 4.4.1.

#### 4.3.2 Application Server (AS)

An AS shall implement the role of a MWI Notifier User Agent as described in subclause 4.4.2.

An AS implementing the role of MWI Notifier User Agent shall implement the role of the AS acting as terminating UA as described in 3GPP TS 24.229 [2], subclause 5.7.2.

Additionally an AS may implement other roles for the receipt and storage of the messages for example Web Server, Mail Transfer and Delivery Agent, Short Message Service centre, etc.

The definition of additional roles for an MWI AS is out of the scope for the current specification.

### 4.4 Roles

#### 4.4.1 MWI Subscriber User Agent (MSUA)

A MSUA is an entity that is subscribed or requests information about status change of message account from an MWI AS.

Actions performed by a MSUA as a part of the UE are described in subclause 4.7.2.1.

#### 4.4.2 MWI Notifier User Agent (MNUA)

The MNUA is an entity that provides information about changes in message account status to the MSUA.

Actions performed by a MWI Notifier User Agent as a part of the AS are described in subclause 4.7.2.5.

#### 4.4.3 Message Account (MA)

##### 4.4.3.0 General

The definition of the message account from the RFC 3842 [3] applies with following additions:

Message account retains multimedia messages (e.g. voice, video and fax) intended to a particular subscriber.

#### 4.4.3.1 Identification of the message account for the message deposit

Since messages may be intended to the different public user identities that belong to the same subscriber, the message account may be configured to retain messages for any of the subscriber's public user identities.

Configuration of a message account to retain messages for each public user identity, for a group of public user identities or for all of public user identities that belong to the same subscriber is subject to the operator's policy.

#### 4.4.3.2 Identification of the message account for the MWI subscription

For the identification of the message account by subscriptions to the MWI service any of a subscriber's public user identities can be used (see examples in subclause A.1.1.2).

### 4.5 Operational requirements

#### 4.5.1 Provision/withdrawal

The MWI service is provided after prior arrangement with the service provider. The MWI service shall be withdrawn at the subscriber's request or for administrative reasons.

Any of the subscriber's public user identities can be used to access the MWI service, see annex B.

#### 4.5.2 Requirements on the originating network side

No specific requirements are needed on the originating network side.

NOTE: Annex B includes an example of an iFC that can be used to invoke the MWI supplementary service.

#### 4.5.3 Requirements in the network

No specific requirements are needed in the network.

#### 4.5.4 Requirements on the terminating network side

No specific requirements are needed in the network.

### 4.6 Coding requirements

The application/simple-message-summary MIME type used to provide Message Summary and Message Waiting Indication Information is defined in subclause 5 of RFC 3842 [3].

The coding of the message types in the message-context-class values is defined in the specifications listed in the "reference" column of table 1.

**Table 1: Coding requirements**

Value	Reference
voice-message	RFC 3458 [5]
video-message	RFC 3938 [6]
fax-message	RFC 3458 [5]
pager-message	RFC 3458 [5]
multimedia-message	RFC 3458 [5]
text-message	RFC 3458 [5]
none	RFC 3458 [5]

The coding of the additional information about deposited messages in the application/simple-message-summary MIME body is defined in subclause 25 of RFC 3261 [11] for SIP extension-header (subclause 3.5 of RFC 3842 [3]) and follow the rules defined in the specifications listed in the "reference" column of table 2.

**Table 2: Additional information**

Header	Description	Reference
To:	Indicates the subscriber's public user identity used by correspondent to deposit a message.	subclause 3.6.3 of RFC 2822 [7]
From:	Indicates the correspondent's public user identity, if available.	subclause 3.6.2 of RFC 2822 [7]
Subject:	Indicates the topic of the deposited message as provided by correspondent.	subclause 3.6.5 of RFC 2822 [7]
Date:	Indicates the time and date information about message deposit.	subclause 3.6.1 of RFC 2822 [7]
Priority:	Indicates the message priority as provided by correspondent.	RFC 2156 [8]
Message-ID:	Indicates a single unique message identity.	subclause 3.6.4 of RFC 2822 [7]
Message-Context:	Indicates a type or context of message.	RFC 3458 [5]

## 4.7 Signalling requirements

### 4.7.1 Activation/deactivation

The MWI service is immediately activated after the SUBSCRIBE request from the MSUA is successfully processed, see subclause 4.7.2.

The MWI service is deactivated after subscription expiry or after unsuccessful attempt to deliver a notification about message waiting.

#### 4.7.1A Registration/erasure

The MWI service requires no registration. Erasure is not applicable.

#### 4.7.1B Interrogation

Interrogation of MWI is not applicable.

### 4.7.2 Invocation and operation

#### 4.7.2.1 Actions at the MSUA

When the MSUA intends to subscribe for status information changes of a message account, the MSUA shall generate a SUBSCRIBE request in accordance with RFC 6665 [4] and RFC 3842 [3] and in alignment with the procedures described in 3GPP TS 24.229 [2]. If the UE receives a 489 (Bad Event) response or a 405 (Method Not Allowed) response to the SUBSCRIBE request, the UE shall not re-try the SUBSCRIBE request until de-registration of the public user identity from IMS.

NOTE: 489 (Bad Event) response or 405 (Method Not Allowed) response to the SUBSCRIBE request indicates that MWI is not supported in the network.

The MSUA will address the SUBSCRIBE request to one of the subscriber's public user identities (see subclause 4.5.1).

The MSUA shall implement the "application/simple-message-summary" content type as described in RFC 3842 [3].

4.7.2.2 Void

4.7.2.3 Void

4.7.2.4 Void

#### 4.7.2.5 Actions at the MNUA

When the MNUA receives a SUBSCRIBE request for the "message-summary" event package, the MNUA shall identify the message account which status information is requested (see subclause 4.4.3.2), then the MNUA shall attempt to verify the identity of the source of the SUBSCRIBE request as described in 3GPP TS 24.229 [2] subclause 5.7.1.4, then perform authorization according to 3GPP TS 24.229 [2] subclause 5.7.1.5.

In case of successful subscription, the MNUA shall generate a response to the SUBSCRIBE request and notifications in accordance with RFC 6665 [4] and RFC 3842 [3], and as defined by subclause 4.6.

4.7.2.6 Void

4.7.2.7 Void

4.7.2.8 Void

4.7.2.9 Void

## 4.8 Interaction with other IMS capabilities

4.8.1 Void

4.8.2 Void

## 4.9 Interaction with other services

### 4.9.1 Communication Hold (HOLD)

No impact, i.e. neither service shall affect the operation of the other service.

### 4.9.2 Terminating Identification Presentation (TIP)

No impact, i.e. neither service shall affect the operation of the other service.

### 4.9.3 Terminating Identification Restriction (TIR)

No impact, i.e. neither service shall affect the operation of the other service.

### 4.9.4 Originating Identification Presentation (OIP)

No impact, i.e. neither service shall affect the operation of the other service.

### 4.9.5 Originating Identification Restriction (OIR)

No impact, i.e. neither service shall affect the operation of the other service.

### 4.9.6 CONFerence calling (CONF)

No impact, i.e. neither service shall affect the operation of the other service.

### 4.9.7 Communication DIVersion services (CDIV)

#### 4.9.7.0 General

The subscriber of the message waiting indication service receives the notifications about the change in the status of message account only from .

Communication diversion services shall not impact the processing of message waiting indication subscriptions, notifications and responses.

#### 4.9.7.1 Communication Forwarding Unconditional (CFU)

MWI notifications shall not be affected by the communication forwarding unconditional service and always be forwarded to subscribers' current location (if known).

#### 4.9.7.2 Communication Forwarding Busy (CFB)

MWI notifications shall not be affected by the communication forwarding busy service and always be forwarded to subscribers' current location (if known).

The UE will inform the AS if it will not be able to process the notification at the time.

#### 4.9.7.3 Communication Forwarding No Reply (CFNR)

MWI notifications shall not be affected by the communication forwarding busy service and always be forwarded to subscribers' current location (if known).

The S-CSCF will inform the AS if the UE can not be contacted at the time.

#### 4.9.7.4 Communication Forwarding on Not Logged-in (CFNL)

MWI notifications shall not be affected by the communication forwarding busy service and always be forwarded to subscribers' current location (if known).

The S-CSCF will inform the AS if the UE is not logged-in at the time.

#### 4.9.7.5 Communication Deflection (CD)

MWI notifications shall not be affected by the communication deflection service. The AS shall ignore the redirection information received from the UE and process a 3xx response as a 480 Temporarily Unavailable response.

#### 4.9.8 Malicious Call IDentification (MCID)

No impact, i.e. neither service shall affect the operation of the other service.

#### 4.9.9 Explicit Communication Transfer (ECT)

No impact, i.e. neither service shall affect the operation of the other service.

#### 4.9.10 Enhanced Calling Name (eCNAM)

No impact, i.e. neither service shall affect the operation of the other service.

### 4.10 Interactions with other networks

Interaction with other networks is performed according to 3GPP TS 24.229 [2].

#### 4.10.1 Void

#### 4.10.2 Void

#### 4.10.3 Void

### 4.11 Parameter values (timers)

Not applicable.

---

# Annex A (informative): Example signalling flows of Message Waiting Indication (MWI) service operation

## A.1 Scope of signalling flows

This annex gives examples of signalling flows for the Message Waiting Indication service within the IM CN subsystem based on the Session Initiation Protocol (SIP).

### A.1.1 Introduction

#### A.1.1.1 General

The signalling flows provided in the following subclauses follow the methodology developed in 3GPP TS 24.228 [12]. The following additional considerations apply.

#### A.1.1.2 Key required to interpret signalling flows

The key to interpret signalling flows specified in 3GPP TS 24.228 [12] subclauses 4.1 and 4.2 applies with the additions specified below:

- mwi.home1.net: an MWI AS in the home network of the service provider;
- user1\_public1@home1.net: subscriber's first public user identity assigned to the message account;
- user1\_public2@home1.net: subscriber's second public user identity assigned to the message account;
- user2\_public1@home2.net: first correspondent of messages in the message account;
- user3\_public1@home3.net: second correspondent of messages in the message account.

Each signalling flow table contains descriptions for headers where the content of the header is new to that signalling flow, as is already performed in 3GPP TS 24.228 [12].

However, 3GPP TS 24.228 [12] includes extensive descriptions for the contents of various headers following each of the tables representing the contents of the signalling flows. Where the operation of the header is identical to that shown in 3GPP TS 24.228 [12], then such text is not reproduced in the present document.

Headers following the tables that are represented in *fat cursive* style describe the contents of the application/simple-message-summary MIME body.

Additional text is also found on the contents of headers within 3GPP TS 24.228 [12] in addition to the material shown in the present document.

## A.1.2 Signalling flows demonstrating how UE subscribes to message waiting indication event notification

### A.1.2.1 Introduction

Subclause A.1.2 covers the signalling flows that show how UE can request message waiting indication information from an application server.

#### A.1.2.2 MWI Subscriber subscribing to the status of his message account, MWI AS is in the subscriber's network

Successful subscription, UE in visited network. This example shows the case when the originating S-CSCF, routes the SUBSCRIBE request to an AS that provides the MWI service, based on the resolution of the public service identity of the message account.



```
Expires: 7200
Accept: application/simple-message-summary
Contact: <sip:user1_public1@1.2.3.4:1357>
Content-Length: 0
```

**Request URI:** Public service identity of the user of the message account whose events the subscriber subscribes to. In this case the subscriber subscribes to the message waiting indication events.

**Event:** This field is populated with the value "message-summary" to specify the use of the Message Summary Package.

**Accept:** This field is populated with the value "application/simple-message-summary" as described in RFC 3842 [3].

**To:** Same as the Request-Uri.

## 2. SUBSCRIBE request (P-CSCF to S-CSCF) - see example in table A.2

The SUBSCRIBE request is forwarded to the I-CSCF.

The P-CSCF looks up the serving network information for the public user identity that was stored during the registration procedure. The SUBSCRIBE request is forwarded to S-CSCF#1. A Route header is inserted into SUBSCRIBE request. The information for the Route header is taken from the service route determined during registration.

**Table A.2: SUBSCRIBE request (P-CSCF to S-CSCF)**

```
SUBSCRIBE sip:user1_public1@home1.net SIP/2.0
Via: SIP/2.0/UDP pscsf1.visited1.net;branch=z9hG4bK120f34.1, SIP/2.0/UDP
1.2.3.4:1357;comp=sigcomp;branch=z9hG4bKehuefdam
P-Access-Network-Info:
Route: <sip:orig@scscf1.home1.net;lr>
Max-Forwards: 69
P-Asserted-Identity: <sip:user1_public1@home1.net>
P-Charging-Vector: icid-value="AyretyU0dm+6O2IrT5tAFrbHLso=223551024"
Privacy:
Record-Route: <sip:pscscf1.visited1.net;lr>
Route: <sip:scscf1.home1.net;lr>
From:
To:
Call-ID:
CSeq:
Event:
Supported:
Expires:
Accept:
Contact:
Content-Length:
```

## 3. Evaluation of initial filter criteria

The S-CSCF validates the service profile of this subscriber and evaluates the initial filter criteria. Assuming that sip:user1\_mwiacc1@home1.net is a statically created PSI, sip:user1\_mwiacc1@home1.net is included in the service profile of user1\_public1@home1.net as part of an originating initial Filter Criteria with Service Trigger Point of Method = SUBSCRIBE AND Event = "message-summary" AND Request-URI = sip:user1\_mwiacc1@home1.net, that informs the S-CSCF to route the SUBSCRIBE request to the application server sip:mwi.home1.net.

If there is no initial filter criteria for this PSI (sip:user1\_mwiacc1@home1.net), the assumption is that the PSI is a sub domain-based PSI. The procedure defined in RFC 3263 [9] with DNS NAPTR and SRV queries aligned with the operator policy is then be used for the resolution of the PSI.

## 4. SUBSCRIBE (S-CSCF to AS) - see example in table A.3

The S-CSCF forwards the SUBSCRIBE request to AS.



**Table A.3: SUBSCRIBE request (S-CSCF to AS)**

```

SUBSCRIBE sip:user1_public1@home1.net SIP/2.0
Via: SIP/2.0/UDP scscf1.home1.net;branch=z9hG4bK344a65.1, SIP/2.0/UDP
pcscf1.visited1.net;branch=z9hG4bK120f34.1, SIP/2.0/UDP 1.2.3.4:1357;branch=z9hG4bKehuefdam
Max-Forwards: 68
P-Asserted-Identity: <sip:user1_public1@home1.net>, <tel:+1-212-555-1111>
P-Charging-Vector:
P-Charging-Function-Addresses:
Privacy:
Record-Route: <sip:orig@scscf1.home1.net;lr>, <sip:pcscf1.visited1.net;lr>
Route: <sip:mwi.home1.net;lr>, <sip:orig@scscf1.home1.net;lr>
From:
To:
Call-ID:
CSeq:
Event:
Supported:
Expires:
Accept:
Contact:
Content-Length:

```

### 5. Identification of the message account and subscriber authorization

Based on the Request-URI the MWI AS identifies the requested message account.

P-Asserted-Identity header information authorizes the subscriber to subscribe to status change of the message account, as one of the identities is authorized for this account.

In this example the authorization is successful, so the AS sends a 200 (OK) response to the S-CSCF. If the previous condition failed, then a 403 (Forbidden) response would be sent to the S-CSCF.

### 6. 200 (OK) response (MWI AS to S-CSCF) – see example in table A.4

The MWI AS forwards the response to the S-CSCF.

**Table A.4: 200 (OK) response (AS to S-CSCF)**

```

SIP/2.0 200 OK
Via: SIP/2.0/UDP scscf1.home1.net;branch=z9hG4bK344a65.1, SIP/2.0/UDP
pcscf1.visited1.net;branch=z9hG4bK120f34.1, SIP/2.0/UDP 1.2.3.4:1357;branch=z9hG4bKehuefdam
P-Charging-Vector: icid-value="AyretyU0dm+6O2IrT5tAFrbHLSo=223551024"; orig-ioi=home1.net; term-
ioi=home1.net
Record-Route:
From: <sip:user1_public1@home1.net>;tag=31415
To: <sip:user1_public1@home1.net>;tag=151170
Call-ID: b89rjhnedlrfjflslj40a222
CSeq:
Expires:
Contact: <sip:mwi.home1.net>
Content-Length: 0

```

### 7. 200 (OK) response (S-CSCF to P-CSCF)

The S-CSCF forwards the 200 (OK) response to the P-CSCF.

### 8. 200 (OK) response (P-CSCF to UE)

P-CSCF forwards the 200 (OK) response to the UE.

### 9. NOTIFY request (MWI AS to S-CSCF) - see example in table A.5

As required by the RFC 6665 [4] the MWI AS immediately after successful subscription sends the NOTIFY request to the S-CSCF to synchronize the current state of the message account at the subscriber's UE. This initial notification contains no extended information about available message. Further notifications sent by MWI AS is contain either extended or basic set of message waiting information as described in RFC 3842 [3].

In this example it is assumed that the message account at the moment of subscription has three voice messages (two new and one old, with one new message being urgent), one old video message and two fax messages (one new and one old with the old message being urgent).

**Table A.5: Initial NOTIFY request (MWI AS to S-CSCF)**

```
NOTIFY sip:user1_public1@1.2.3.4:1357 SIP/2.0
Via: SIP/2.0/UDP mwi.home1.net;branch=z9hG4bK332b23.1
Max-Forwards: 70
Route: <sip:scscf1.home1.net;lr>, <sip:pcscf1.home1.net;lr>
From: <sip:user1_public1@home1.net>;tag=31415
To: <sip:user1_public1@home1.net>;tag=151170
Call-ID: b89rjhnedlrfjflslj40a222
CSeq: 42 NOTIFY
Subscription-State: active;expires=7200
Event: message-summary
Contact: <sip:mwi.home1.net>
Content-Type: application/simple-message-summary
Content-Length: (...)

Messages-Waiting: yes
Message-Account: sip:user1_public1@home1.net
Voice-Message: 2/1 (0/0)
Video-Message: 0/1 (0/0)
Fax-Message: 1/1 (0/1)
```

**Content-Type:** Set to "application/simple-message-summary" as described in RFC 3842 [3].

The message body in the NOTIFY request that carries the message waiting indication is formed as described in subclause 4.6.

**Message-Account:** The MWI AS populates this field with the public user identity used to access the message account that received the subscription.

**Voice-Message:** The MWI AS populates this field with the information about voice messages that are waiting in the message account.

**Video-Message:** The MWI AS populates this field with the information about video messages that are waiting in the message account.

**Fax-Message:** The MWI AS populates this field with the information about fax messages that are waiting in the message account.

## 12. 200 (OK) response (UE to P-CSCF)

The UE acknowledges the NOTIFY request with a 200 (OK) response to the P-CSCF.

## 15. notifications on message-summary event package

After the MWI AS generated a NOTIFY request to inform the subscriber's UE about the subscription state, the MWI AS waits for the change of the message account status. As soon as new message(s) are deposited into the message account the MWI AS generates a NOTIFY request to indicate the change in the message account status to the subscriber's UE.

## 16. NOTIFY request (AS to S-CSCF) – see example in table A.6

The MWI AS uses available information from the interaction with correspondents and message left in the message account to fill the headers in the simple-message-summary MIME body of the NOTIFY request. This notification sent by the MWI AS contains an extended set of message waiting information about newly deposited messages since the last notification as described in RFC 3842 [3].

In this example it is assumed that the subscriber's message account has received three new messages (two urgent voice and one non urgent video message) since the successful immediate NOTIFY transaction from the correspondents sip:user2\_public1@home1.net and sip:user3\_public1@home3.net. The correspondents used different public user identities of the subscriber to deposit messages.

Table A.6: NOTIFY request (MWI AS to S-CSCF)

```

NOTIFY sip:user1_public1@1.2.3.4:1357 SIP/2.0
Via: SIP/2.0/UDP mwi.home1.net;branch=z9hG4bK332b23.1
Max-Forwards: 70
Route: <sip:scscf1.home1.net;lr>, <sip:pcscf1.home1.net;lr>
From: <sip:user1_public1@home1.net>;tag=31415
To: <sip:user1_public1@home1.net>;tag=151170
Call-ID: b89rjhnedlrfjflslj40a222
CSeq: 43 NOTIFY
Subscription-State: active;expires=5000
Event: message-summary
Contact: <sip:mwi.home1.net>
Content-Type: application/simple-message-summary
Content-Length: (...)

Messages-Waiting: yes
Message-Account: sip:user1_public1@home1.net
Voice-Message: 4/1 (2/0)
Video-Message: 1/1 (0/0)
Fax-Message: 1/1 (0/1)

To: <user1_public1@home1.net>
From: <user2_public1@home1.net>
Subject: call me back!
Date: 19 Apr 2005 21:45:31 -0700
Priority: urgent
Message-ID: 27775334485@mwi.home1.net
Message-Context: voice-message

To: <user1_public2@home1.net>
From: <user2_public1@home1.net>
Subject: Where are you that late???
Date: 19 Apr 2005 23:45:31 -0700
Priority: urgent
Message-ID: 27775334485@mwi.home1.net
Message-Context: voice-message

To: <user1_public1@home1.net>
From: <user3_public1@home3.net>
Subject: Did you see that penalty!!!
Date: Tue, 19 Apr 2005 22:12:31 -0700
Priority: normal
Message-ID: 26775334485@mwi.home1.net
Message-Context: video-message

```

**Content-Type:** Set to "application/simple-message-summary" as described in RFC 3842 [3].

The message body in the NOTIFY request that carries the message waiting indication is formed as described in the subclause 4.6.

**Message-Account:** The MWI AS populates this field with the public user identity used to access the message account that has new messages for the subscriber.

**Voice-Message:** Since two new urgent voice messages were received by the message account, the number of new voice messages is increased to four and the number of the new urgent messages is increased to two.

**Video-Message:** One new video message was received by the message account and accordingly the number of new video messages set to one.

**Fax-Message:** No new fax messages were received by the message account, so the number of fax messages is unchanged.

**To:** This header in the MIME body populates the information about the public user identity of subscriber, that was used by correspondent to deposit a message.

**From:** This header in the MIME body populates the information about the public user identity, of correspondent, that left a message to the subscriber.

**Subject:** This header populates the information about the subject, that was assigned to the left message by correspondent.

- Date:** This header populates the information about the date and time when a message was left.
- Priority:** This header populates the information about the message urgency assigned by correspondent.
- Message-ID:** This header populates the information about the message identity, that is assigned to the message by the MWI AS.
- Message-Context:** This header populates the information about the type of the deposited message, that has the extended set of message waiting information.

### A.1.2.3 Void

## A.1.3 Signalling flows demonstrating how AS sends message waiting indication notification to the UE which does not implement RFC 3842

Editor's note: [MAINT\_R2, CR#0016]. This subclause details a flow that is not supported in the normative procedures, and does not therefore at the moment form part of the specification. As such it has been deleted from earlier releases, but has been retained in this version of the specification for further consideration. It may subsequently be supported in this specification or deleted.

### A.1.3.1 Introduction

Subclause A.1.3 covers the signalling flows that show how MWI AS sends message waiting indication information to the UE which does not implement RFC 3842 [3].

### A.1.3.2 Registration signalling for MWI subscriber

This example shows the registration signalling for MWI subscriber.

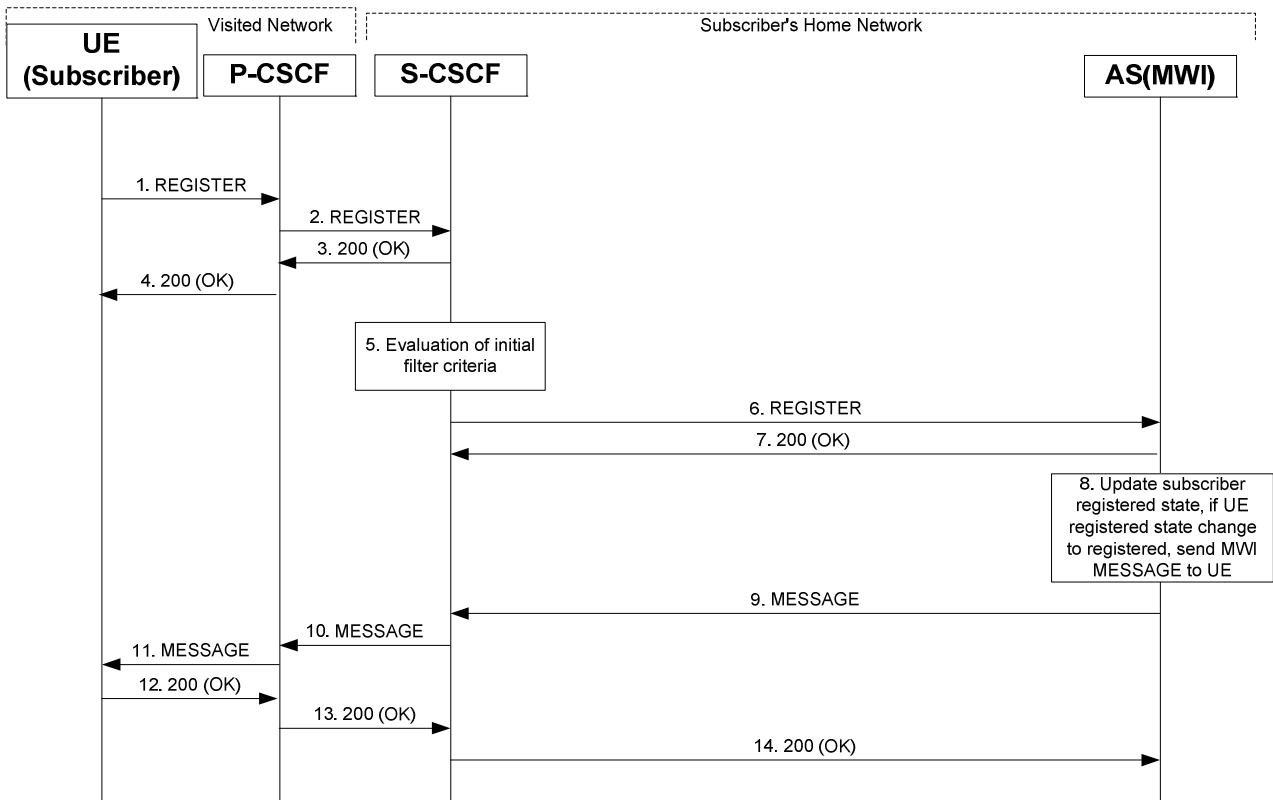

Figure A.3: Registration signalling for MWI subscriber

When the MWI subscriber registered state changes, e.g. initiate the register procedure, S-CSCF evaluates the initial filter criteria, initiate a third party registration procedure by sending a REGISTER request to MWI AS. The MWI AS is also subscribe to the reg event package for the public user identity registered at the users registrar (S-CSCF) to receive the subscriber's registration state information, see 3GPP TS 24.229 [2], subclause 5.7.1.1.

The details of the signalling flows are followed:

#### 1. REGISTER request (UE to P-CSCF) – see example in table A.8

The purpose of this request is to register the user's SIP URI with an S-CSCF in the home network. This request is routed to the P-CSCF.

**Table A.8: REGISTER request (UE to P-CSCF)**

```
REGISTER sip:home1.net SIP/2.0
Via: SIP/2.0/UDP 1.2.3.4:1357;branch=z9hG4bKnashds7
Max-Forwards: 70
Route: <sip:pcscf1.visited1.net:7531;lr>
From: <sip:user1_public1@home1.net>;tag=31415
To: <sip:user1_public1@home1.net>
Contact: <sip:user1_public1@1.2.3.4:1357>
Call-ID: b89rjhnedlrfjflslj40a222
CSeq: 61 REGISTER
Content-Length: 0
```

#### 2. REGISTER request (P-CSCF to S-CSCF) – see example in table A.9

P-CSCF forwards the REGISTER request to the S-CSCF in MWI subscriber's home network through I-CSCF.

**Table A.9: REGISTER request (P-CSCF to S-CSCF)**

```
REGISTER sip:home1.net SIP/2.0
Via: SIP/2.0/UDP pcscf1.visited1.net;branch=z9hG4bk120f34.1
Via: SIP/2.0/UDP 1.2.3.4:1357;branch=z9hG4bKnashds7
Route: <sip:orig@scscf1.home1.net>
Max-Forwards: 68
Route: <sip:pcscf1.visited1.net:7531;lr>
From: <sip:user1_public1@home1.net>;tag=31415
To: <sip:user1_public1@home1.net>
Contact: <sip:user1_public1@1.2.3.4:1357>
Call-ID: b89rjhnedlrfjflslj40a222
CSeq: 61 REGISTER
Content-Length: 0
```

#### 3. 200 (OK) response (S-CSCF to P-CSCF) – see example in table A.10

S-CSCF authorizes the REGISTER request and send 200 (OK) to P-CSCF.

**Table A.10: 200 (OK) response (S-CSCF to P-CSCF)**

```
SIP/2.0 200 OK
Via: SIP/2.0/UDP pcscf1.visited1.net;branch=z9hG4bk120f34.1
Via: SIP/2.0/UDP 1.2.3.4:1357;branch=z9hG4bKnashds7
From: <sip:user1_public1@home1.net>;tag=31415
To: <sip:user1_public1@home1.net>;tag=kotimaaa
Contact: <sip:user1_public1@1.2.3.4:1357>
Call-ID: b89rjhnedlrfjflslj40a222
CSeq: 61 REGISTER
Content-Length: 0
```

#### 4. 200 (OK) response (P-CSCF to UE)

P-CSCF forwards the 200 (OK) response to the UE.

#### 5. Evaluation of initial filter criteria

After subscriber register to the S-CSCF successfully, S-CSCF will get the service profile of subscriber from USPF and evaluates the initial filter criteria.

For the MWI subscriber, S-CSCF will initiate a third party registration procedure to the AS.

#### 6. REGISTER request (S-CSCF to AS) – see example in table A.11

The purpose of this request is to notify the registered status to the AS.

**Table A.11: REGISTER request (S-CSCF to AS)**

```
REGISTER sip:mwi.home1.net SIP/2.0
Via: <sip:scscf1.home1.net>;branch=99sctb
Max-Forwards: 70
From: <sip:scscf1.home1.net>;tag=31415
To: <sip:user1_public1@home1.net>
Contact: <sip:scscf1.home1.net>
Call-ID: las22kdoa45siewrf
CSeq: 85 REGISTER
Content-Length: 0
```

#### 7. 200 (OK) response (AS to S-CSCF) – see example in table A.12

AS receive the REGISTER request from S-CSCF and send a 200 (OK) response to S-CSCF.

**Table A.12: REGISTER request (AS to S-CSCF)**

```
SIP/2.0 200 OK
Via: <sip:scscf1.home1.net>;branch=99sctb
Max-Forwards: 70
From: <sip:scscf1.home1.net>;tag=31415
To: <sip:user1_public1@home1.net>
Contact: <sip:scscf1.home1.net>
Call-ID: las22kdoa45siewrf
CSeq: 85 REGISTER
Content-Length: 0
```

#### 8. AS updates the MWI subscriber registered state

AS updates the MWI subscriber registered state.

If MWI subscriber registered state changes to registered, AS sends the MWI notification to UE.

#### 9. MESSAGE request (MWI AS to S-CSCF) – see example in table A.13

In this example it is assumed that the message account at the moment of registration has three voice message, one old video message and two fax messages.

**Table A.13: MESSAGE request (MWI AS to S-CSCF)**

```
MESSAGE sip:user1_public1@1.2.3.4:1357 SIP/2.0
Via: SIP/2.0/UDP mwi.home1.net;branch=z9hG4bK332b23.1
Max-Forwards: 70
Route: <sip:scscf1.home1.net;lr>, <sip:pcscf1.home1.net;lr>
From: <sip:user1_mwiacc1@home1.net>;tag=31415
To: <sip:user1_public1@home1.net>;tag=151170
Call-ID: b89rjhnedlrfjflslj40a222
CSeq: 42 MESSAGE
Content-Type: text/plain
Content-Length: (...)

You Have new messages on sip:user1_mwiacc1@home1.net!
2 Voice-Messages, 1 Video-Messages, 1 Fax-Message in your mailbox,
to get detail, please visit sip:mwi.home1.net.
```

**Content-Type:** Set to "text/plain" as described in RFC 3428 [16].

The message body in the MESSAGE request that carries the message waiting indication information in pure text format.

#### 12. 200 (OK) response (UE to P-CSCF)

The UE acknowledges the MESSAGE request with a 200 (OK) response to the P-CSCF.

### A.1.3.3 AS notify subscriber when message account state change

This example shows the case AS notify subscriber changes in the status of message account.

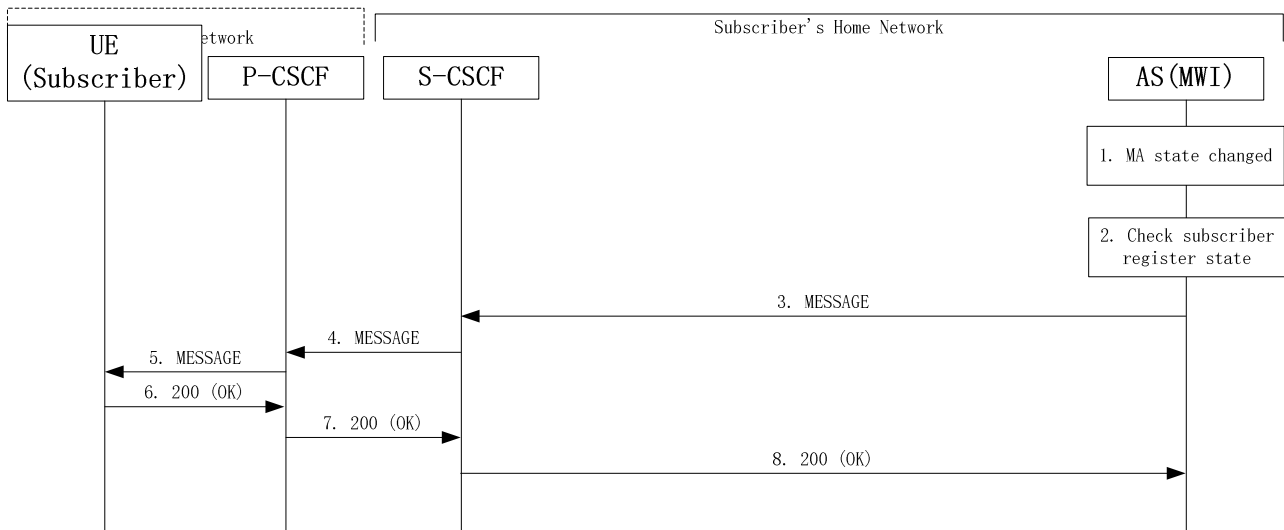

**Figure A.4: AS notify MWI subscriber when message account state change**

When the message account state changes, AS sends the message waiting indication to the UE.

The details of the signalling flows are followed:

#### 1. Message Account state change

When new message is deposited into the subscribers message account, the Message Account state is changed.

#### 2. AS check MWI subscriber registered state

AS check the MWI subscriber registered state, if the subscriber is registered, AS will send the message waiting indication to the UE.

#### 3. MESSAGE request (MWI AS to S-CSCF) – see example in table A.14

AS sends the message waiting indication to UE.

**Table A.14: MESSAGE request (MWI AS to S-CSCF)**

```

MESSAGE sip:user1_public1@1.2.3.4:1357 SIP/2.0
Via: SIP/2.0/UDP mwi.home1.net;branch=z9hG4bK332b23.1
Max-Forwards: 70
Route: <sip:scscf1.home1.net;lr>, <sip:pcscf1.home1.net;lr>
From: <sip:user1_mwiacc1@home1.net>;tag=31415
To: <sip:user1_public1@home1.net>;tag=151170
Call-ID: b89rjhnedlrfjflslj40a222
CSeq: 42 MESSAGE
Content-Type: text/plain
Content-Length: (...)

You Have new messages on sip:user1_mwiacc1@home1.net!
1 new Voice-Messages in your mailbox,
to get detail, please visit sip:mwi.home1.net.
  
```

#### 6. 200 (OK) response (UE to P-CSCF)

The UE acknowledges the MESSAGE request with a 200 (OK) response to the P-CSCF.

## A.1.4 Signalling flows demonstrating how a message is deposited into the subscribers message account

### A.1.4.1 Introduction

Subclause A.1.4 covers the signalling flows that show how a message is deposited into the subscribers message account.

### A.1.4.2 Depositing a message into the subscriber's message account

#### A.1.4.2.1 Successful message deposit into the subscriber's message account

This call-flow shows the deposit of the message in to the subscriber's message account by a correspondent.

"Integration of resource management and SIP" not required by the MWI AS and not used by correspondent's UE.

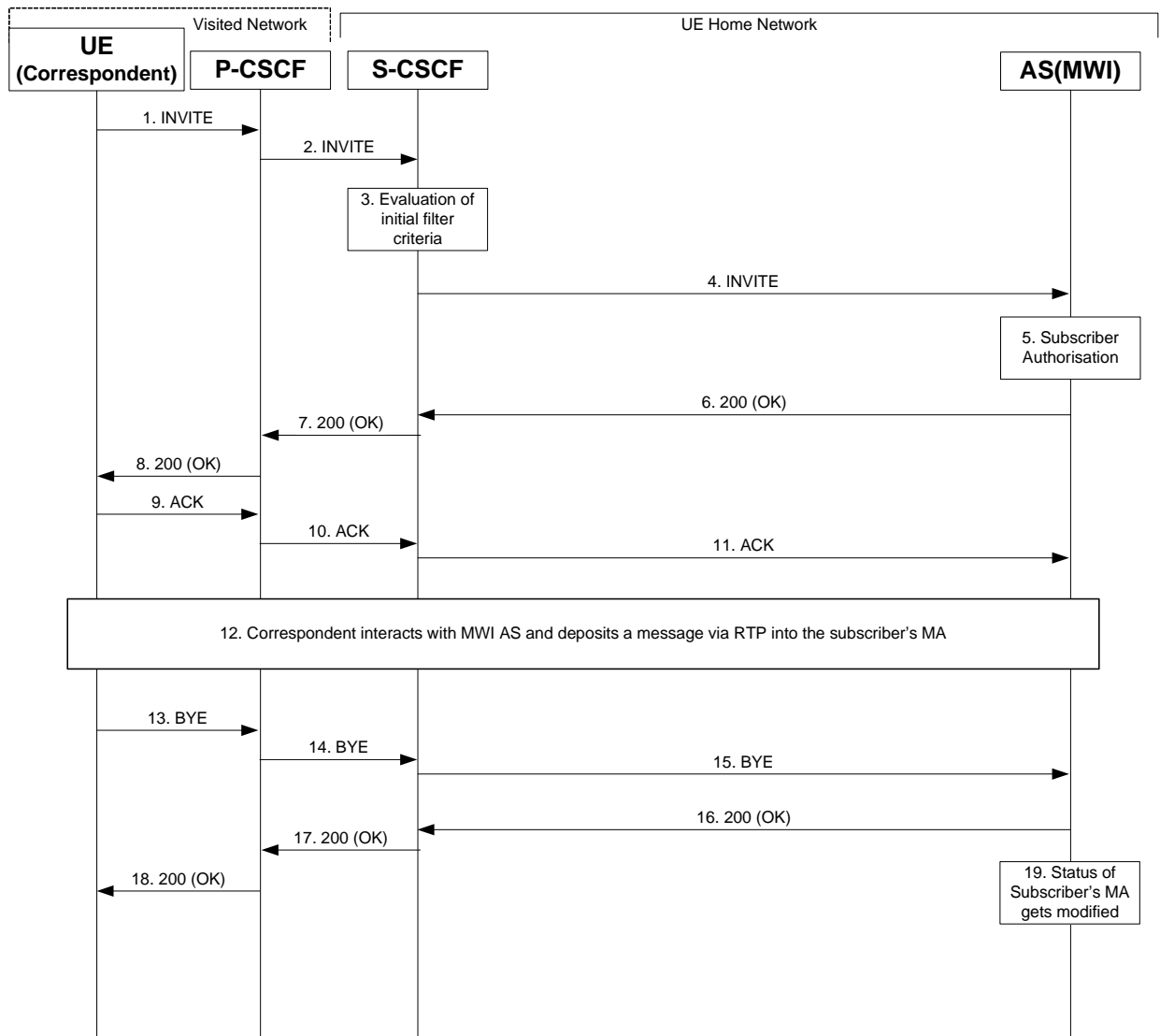

Figure A.5: Correspondent depositing a message into the subscriber's MA



Figure A.5 shows a correspondent user equipment creating, interacting over RTP and terminating a session with the MWI AS. The details of the signalling flows are as follows:

### 1. INVITE request (Correspondent to P-CSCF) – see example in table A.15

A correspondent wishes to initiate a session with the MWI subscriber. To initiate the session, the correspondent generates an INVITE request to MWI subscriber.

**Table A.15: INVITE request (UE to P-CSCF)**

```
INVITE sip:user1_public1@home1.net SIP/2.0
Via: SIP/2.0/UDP 2.3.4.5:2468;branch=0uetb
Max-Forwards: 70
Route: <sip:pcscf1.visited2.net:8642;lr>;, <sip:orig@scscf1.home3.net;lr>
P-Preferred-Identity: <sip:user3_public1@home3.net>
Privacy: none
From: <sip:user3_public1@home3.net>;tag=31417
To: <sip:user1_public1@home1.net>
Call-ID: apb03a0s09dkjdfgk49111
CSeq: 22 INVITE
Contact: <sip:user3_public1@2.3.4.5:2468>
Content-Type: application/sdp
Content-Length: (...)

v=0
o=user3 2890844526 2890844526 IN IP4 2.3.4.5
s=-
c=IN IP4 2.3.4.5
t=0 0
m=audio 49172 RTF/AVP 0
a=rtpmap:0 PCMU/8000
```

**Request URI:** Public user identity of the MWI subscriber.

**From:** Public user identity of the Correspondent.

**To:** Same as the Request-Uri.

**Content-Type:** Set to "application/sdp".

The message body includes the SDP information.

### 2. INVITE request (P-CSCF to S-CSCF) – see example in table A.16

The INVITE request is forwarded to the S-CSCF in MWI subscriber's home network.

**Table A.16: INVITE request (S-CSCF to S-CSCF)**

```
INVITE sip:user1_public1@home1.net SIP/2.0
Via: SIP/2.0/UDP scscf1.home3.net;branch=z9bhks13dlc23xm
Via: SIP/2.0/UDP pcscf1.visited2.net;branch=z9hG4bK120f34.1
Via: SIP/2.0/UDP 2.3.4.5:2468;comp=sigcomp;branch=z9hG4bKehuefdam
Record-Route: <sip:orig@scscf1.home3.net;lr>
Record-Route: <sip:pcscf1.visited2.net:8642;lr>
Max-Forwards: 68
Privacy: none
From: <sip:user3_public1@home2.net>;tag=31417
To: <sip:user1_public1@home1.net>
Call-ID: apb03a0s09dkjdfgk49111
CSeq: 22 INVITE
Contact: <sip:user3_public1@2.3.4.5:2468>
Content-Type: application/sdp
Content-Length: (...)

v=0
o=user3 2890844526 2890844526 IN IP4 2.3.4.5
s=-
c=IN IP4 2.3.4.5
t=0 0
m=audio 49172 RTF/AVP 0
a=rtpmap:0 PCMU/8000
```

### 3. Evaluation of initial filter criteria

The S-CSCF validates the service profile of this subscriber and evaluates the initial filter criteria. Assuming that MWI service is included in the service profile of user1\_public1@home1.net as part of an terminating initial Filter Criteria with Service Trigger Point of Method = INVITE AND Request-URI = sip:user1\_public1@home1.net AND subscriber state = logout, that informs the S-CSCF to route the INVITE request to the application server sip:mwi.home1.net when the state of [user1\\_public1@home1.net](#) is logout.

### 4. INVITE (S-CSCF to AS) – see example in table A.17

The S-CSCF forwards the INVITE request to AS.

**Table A.17: INVITE request (S-CSCF to AS)**

```
INVITE sip:user1_public1@home1.net SIP/2.0
Via: SIP/2.0/UDP scscf1.home1.net;branch=z9ack2k2bjbm0fu
Via: SIP/2.0/UDP scscf1.home3.net;branch=z9bhks13dlc23xm
Via: SIP/2.0/UDP pcscf1.visited2.net;branch=z9hG4bK120f34.1
Via: SIP/2.0/UDP 2.3.4.5:2468;comp=sigcomp;branch=z9hG4bKehuefdam
Record-Route: <sip:scscf1.home1.net;lr>
Record-Route: <sip:orig@scscf1.home3.net;lr>
Record-Route: <sip:pcscf1.visited2.net:8642;lr>
Max-Forwards: 67
Privacy: none
From: <sip:user3_public1@home2.net>;tag=31417
To: <sip:user1_public1@home1.net>
Call-ID: apb03a0s09dkjdfgk49111
CSeq: 22 INVITE
Contact: <sip:user3_public1@2.3.4.5:2468>
Content-Type: application/sdp
Content-Length: (...)

v=0
o=user3 2890844526 2890844526 IN IP4 2.3.4.5
s=-
c=IN IP4 2.3.4.5
t=0 0
m=audio 49172 RTF/AVP 0
a=rtpmap:0 PCMU/8000
```

### 5. Identification of the message account and subscriber authorization

Based on the Request-URI the MWI AS identifies the requested message account.

In the requested message account is valid, AS sends a 200 (OK) response to the S-CSCF.

### 6. 200 (OK) response (MWI AS to S-CSCF) – see example in table A.18

The MWI AS forwards the response to the S-CSCF.

**Table A.18: 200 (OK) response (AS to S-CSCF)**

```
SIP/2.0 200 OK
Via: SIP/2.0/UDP scscf1.home1.net;branch=z9ack2k2bjbm0fu
Via: SIP/2.0/UDP scscf1.home3.net;branch=z9bhks13dlc23xm
Via: SIP/2.0/UDP pcscf1.visited2.net;branch=z9hG4bK120f34.1
Via: SIP/2.0/UDP 2.3.4.5:2468;comp=sigcomp;branch=z9hG4bKehuefdam
Record-Route: <sip:scscf1.home1.net;lr>
Record-Route: <sip:orig@scscf1.home3.net;lr>
Record-Route: <sip:pcscf1.visited2.net:8642;lr>
From: <sip:user3_public1@home2.net>;tag=31417
To: <sip:user1_public1@home1.net>
Call-ID: apb03a0s09dkjdfgk49111
CSeq: 22 INVITE
Contact: <sip:user1_mwiacc1@mwi.home1.net>
Content-Type: application/sdp
Content-Length: (...)

v=0
o=user3 2890844527 2890844527 IN IP4 12.13.14.15
s=-
c=IN IP4 12.13.14.15
t=0 0
```

```
m=audio 3456 RTF/AVP 0
a=rtpmap:0 PCMU/8000
```

The Content-Type is set to "application/sdp" and the SDP information in AS is included in the message body.

### 9. ACK request (Correspondent to P-CSCF) – see example in table A.19

The correspondent sends an ACK request to P-CSCF.

**Table A.19: ACK request (UE to P-CSCF)**

```
ACK sip:user1_public1@home1.net SIP/2.0
Via: SIP/2.0/UDP 2.3.4.5:2468;branch=0uetb
Max-Forwards: 70
Route: <sip:pcscf1.visited2.net:8642;lr>, <sip:orig@scscf1.home3.net;lr>
From: <sip:user3_public1@home3.net>;tag=31417
To: <sip:user1_public1@home1.net>
Call-ID: apb03a0s09dkjdfg1k49111
CSeq: 22 ACK
Content-Length: 0
```

### 12. The Correspondent deposits a message to the message account

The correspondent interacts with MWI AS and deposits a message via RTP into the subscriber's message account.

### 13. BYE request (Correspondent to P-CSCF) - see example in table A.20

After deposits a message to the subscriber's message account successfully, the correspondent sends a BYE to release the session.

**Table A.20: BYE request (UE to P-CSCF)**

```
BYE sip:user1_public1@home1.net SIP/2.0
Via: SIP/2.0/UDP 2.3.4.5:2468;branch=0uetb
Max-Forwards: 70
Route: <sip:pcscf1.visited2.net:8642;lr>, <sip:orig@scscf1.home3.net;lr>
From: <sip:user3_public1@home3.net>;tag=31417
To: <sip:user1_public1@home1.net>
Call-ID: apb03a0s09dkjdfg1k49111
CSeq: 22 BYE
Content-Length: 0
```

### 16. 200 (OK) response (MWI AS to S-CSCF) - see example in table A.21

The MWI AS forwards the response to the S-CSCF.

**Table A.21: 200 (OK) response (AS to S-CSCF)**

```
SIP/2.0 200 OK
Via: SIP/2.0/UDP 2.3.4.5:2468;branch=0uetb
Max-Forwards: 70
Route: <sip:pcscf1.visited2.net:8642;lr>, <sip:orig@scscf1.home3.net;lr>
From: <sip:user3_public1@home3.net>;tag=31417
To: <sip:user1_public1@home1.net>
Call-ID: apb03a0s09dkjdfg1k49111
CSeq: 22 BYE
Content-Length: 0
```

### 19. Status of subscriber's MA gets modified

The MWI AS updates the status of the subscriber's message account.

If the MWI service is already invoked by the subscriber, MWI notifies the subscriber about new message being deposited into the subscriber's message account as described in subclause A.1.2.3.

---

## Annex B (informative): Example of a filter criteria

This annex provides an example of a filter criterion that triggers SIP requests that are subject to initial filter criteria evaluation.

Following example shows the Service Point Triggers in an Initial Filter Criteria of the service profile for the subscriber with the public user identity [user1\\_public1@home1.net](mailto:user1_public1@home1.net). This Initial Filter Criteria informs the S-CSCF to route the SUBSCRIBE request to the application server sip:mwi.home1.net that provides MWI service addressed with the public user identity sip:user1\_user1\_public1@home1.net.

Method: SUBSCRIBE  
Event: message-summary  
Request-URI: sip:user1\_public1@home1.net  
Application Server: sip:mwi.home1.net

## Annex C (informative): Void

## Annex D (informative): Change history

Change history							
Date	TSG #	TSG Doc.	CR	Rev	Subject/Comment	Old	New
2006-03					Publication as <b>ETSI TS 183 006</b>		1.1.1
2007-03					Publication as ETSI TS 183 006		1.2.1
2007-12					Conversion to <b>3GPP TS 24.206</b>		1.2.2
2008-01					Technically identical copy as <b>3GPP TS 24.606</b> as basis for further development		1.2.3
2008-02					Implemented C1-080098		1.3.0
2008-03					Rapporteur corrected systematic errors that happened during implementation of C1-080098 (typos, wrong formatting)		1.3.1
2008-04					Implemented C1-080880, C1-080881, C1-081046, C1-081084, C1-081085.		1.4.0
2008-05					Implemented C1-081902, C1-081907, C1-081910.		1.5.0
2008-05					Editorial changes done by MCC	1.5.0	1.5.1
2008-06	CT-40	CP-080327			CP-080327 was approved by CT#40 and version 8.0.0 is created by MCC for publishing	1.5.1	8.0.0
2008-09	CT-41	CP-080533	0001		Correction of minors mistakes in signalling flows	8.0.0	8.1.0
2008-09	CT-41	CP-080533	0002		Applicability statement in scope	8.0.0	8.1.0
2008-09	CT-41	CP-080533	0003		Terminology alignment and modal auxiliary verb usage	8.0.0	8.1.0
2009-12	CT-46				Upgrade to Rel-9	8.1.0	9.0.0
2010-03	CT-47	CP-100121	0006	1	Interaction with presence and messaging	9.0.0	9.1.0
2011-03	CT-51				Upgrade to Rel-10	9.1.0	10.0.0
2011-09	CT-53	CP-110659	0009		Non-configurable MWI account URI	10.0.0	10.1.0
2011-09	CT-53	CP-110657	0012		Updating of references to 24.228	10.0.0	10.1.0
2012-06	CT-56	CP-120291	0016		Removal of misleading material from examples annex	10.1.0	11.0.0
2012-09	CT-57	CP-120583	0017	1	Support of non support of MWI	11.0.0	11.1.0
2013-12	CT-62	CP-130770	0018	2	Updating TS 24.606 to RFC 6665	11.1.0	12.0.0
2015-12	CT-70				Upgrade to Rel-13	12.0.0	13.0.0
Change history							
Date	Meeting	TDoc	CR	Rev	Cat	Subject/Comment	New version
2017-03	CT-75					Upgrade to Rel-14	14.0.0
2017-12	CT-78	CP-173071	0020	2	B	Message Waiting Indication (MWI) using IP Multimedia (IM) Core Network (CN) subsystem	15.0.0

---

# History

<b>Document history</b>		
V15.0.0	July 2018	Publication