

ETSI TS 124 385 V17.0.0 (2022-04)



LTE;
V2X services Management Object (MO)
(3GPP TS 24.385 version 17.0.0 Release 17)



Reference

RTS/TSGC-0124385vh00

Keywords

LTE

ETSI

650 Route des Lucioles
F-06921 Sophia Antipolis Cedex - FRANCE

Tel.: +33 4 92 94 42 00 Fax: +33 4 93 65 47 16

Siret N° 348 623 562 00017 - APE 7112B
Association à but non lucratif enregistrée à la
Sous-Préfecture de Grasse (06) N° w061004871

Important notice

The present document can be downloaded from:

<http://www.etsi.org/standards-search>

The present document may be made available in electronic versions and/or in print. The content of any electronic and/or print versions of the present document shall not be modified without the prior written authorization of ETSI. In case of any existing or perceived difference in contents between such versions and/or in print, the prevailing version of an ETSI deliverable is the one made publicly available in PDF format at www.etsi.org/deliver.

Users of the present document should be aware that the document may be subject to revision or change of status.

Information on the current status of this and other ETSI documents is available at

<https://portal.etsi.org/TB/ETSIDeliverableStatus.aspx>

If you find errors in the present document, please send your comment to one of the following services:

<https://portal.etsi.org/People/CommitteeSupportStaff.aspx>

If you find a security vulnerability in the present document, please report it through our
Coordinated Vulnerability Disclosure Program:

<https://www.etsi.org/standards/coordinated-vulnerability-disclosure>

Notice of disclaimer & limitation of liability

The information provided in the present deliverable is directed solely to professionals who have the appropriate degree of experience to understand and interpret its content in accordance with generally accepted engineering or other professional standard and applicable regulations.

No recommendation as to products and services or vendors is made or should be implied.

No representation or warranty is made that this deliverable is technically accurate or sufficient or conforms to any law and/or governmental rule and/or regulation and further, no representation or warranty is made of merchantability or fitness for any particular purpose or against infringement of intellectual property rights.

In no event shall ETSI be held liable for loss of profits or any other incidental or consequential damages.

Any software contained in this deliverable is provided "AS IS" with no warranties, express or implied, including but not limited to, the warranties of merchantability, fitness for a particular purpose and non-infringement of intellectual property rights and ETSI shall not be held liable in any event for any damages whatsoever (including, without limitation, damages for loss of profits, business interruption, loss of information, or any other pecuniary loss) arising out of or related to the use of or inability to use the software.

Copyright Notification

No part may be reproduced or utilized in any form or by any means, electronic or mechanical, including photocopying and microfilm except as authorized by written permission of ETSI.

The content of the PDF version shall not be modified without the written authorization of ETSI.

The copyright and the foregoing restriction extend to reproduction in all media.

© ETSI 2022.
All rights reserved.

Intellectual Property Rights

Essential patents

IPRs essential or potentially essential to normative deliverables may have been declared to ETSI. The declarations pertaining to these essential IPRs, if any, are publicly available for **ETSI members and non-members**, and can be found in ETSI SR 000 314: "*Intellectual Property Rights (IPRs); Essential, or potentially Essential, IPRs notified to ETSI in respect of ETSI standards*", which is available from the ETSI Secretariat. Latest updates are available on the ETSI Web server (<https://ipr.etsi.org/>).

Pursuant to the ETSI Directives including the ETSI IPR Policy, no investigation regarding the essentiality of IPRs, including IPR searches, has been carried out by ETSI. No guarantee can be given as to the existence of other IPRs not referenced in ETSI SR 000 314 (or the updates on the ETSI Web server) which are, or may be, or may become, essential to the present document.

Trademarks

The present document may include trademarks and/or tradenames which are asserted and/or registered by their owners. ETSI claims no ownership of these except for any which are indicated as being the property of ETSI, and conveys no right to use or reproduce any trademark and/or tradename. Mention of those trademarks in the present document does not constitute an endorsement by ETSI of products, services or organizations associated with those trademarks.

DECT™, **PLUGTESTS™**, **UMTS™** and the ETSI logo are trademarks of ETSI registered for the benefit of its Members. **3GPP™** and **LTE™** are trademarks of ETSI registered for the benefit of its Members and of the 3GPP Organizational Partners. **oneM2M™** logo is a trademark of ETSI registered for the benefit of its Members and of the oneM2M Partners. **GSM®** and the GSM logo are trademarks registered and owned by the GSM Association.

Legal Notice

This Technical Specification (TS) has been produced by ETSI 3rd Generation Partnership Project (3GPP).

The present document may refer to technical specifications or reports using their 3GPP identities. These shall be interpreted as being references to the corresponding ETSI deliverables.

The cross reference between 3GPP and ETSI identities can be found under <http://webapp.etsi.org/key/queryform.asp>.

Modal verbs terminology

In the present document "**shall**", "**shall not**", "**should**", "**should not**", "**may**", "**need not**", "**will**", "**will not**", "**can**" and "**cannot**" are to be interpreted as described in clause 3.2 of the [ETSI Drafting Rules](#) (Verbal forms for the expression of provisions).

"**must**" and "**must not**" are **NOT** allowed in ETSI deliverables except when used in direct citation.

Contents

Intellectual Property Rights	2
Legal Notice	2
Modal verbs terminology.....	2
Foreword.....	9
1 Scope	10
2 References	10
3 Definitions and abbreviations.....	11
3.1 Definitions	11
3.2 Abbreviations	11
4 V2X Communication Provisioning MO.....	11
4.1 Overview	11
5 MO configuration parameters	17
5.1 General	17
5.2 Node: <X>	17
5.3 <X>/Name	17
5.4 Configuration parameters for V2X provisioning.....	17
5.4.1 <X>/V2XProvisioning.....	17
5.4.2 <X>/V2XProvisioning/V2XControlFunctionAddress.....	17
5.4.3 <X>/V2XProvisioning/ToConRefs	18
5.4.4 <X>/V2XProvisioning/ToConRefs/<X>	18
5.4.5 <X>/V2XProvisioning/ToConRefs/<X>/ConRef	18
5.5 Configuration parameters for V2X communication over PC5	18
5.5.1 <X>/V2XoverPC5	18
5.5.2 <X>/V2XoverPC5/Expiration	18
5.5.3 <X>/V2XoverPC5/ServedByEUTRAN	19
5.5.4 <X>/V2XoverPC5/ServedByEUTRAN/AuthorizedPLMNs.....	19
5.5.5 <X>/V2XoverPC5/ServedByEUTRAN/AuthorizedPLMNs/<X>	19
5.5.6 <X>/V2XoverPC5/ServedByEUTRAN/AuthorizedPLMNs/<X>/PLMN	19
5.5.7 <X>/V2XoverPC5/NotServedByEUTRAN	20
5.5.8 <X>/V2XoverPC5/NotServedByEUTRAN/Authorized	20
5.5.9 <X>/V2XoverPC5/NotServedByEUTRAN/RadioParameters	20
5.5.10 <X>/V2XoverPC5/NotServedByEUTRAN/RadioParameters/<X>.....	20
5.5.11 <X>/V2XoverPC5/NotServedByEUTRAN/RadioParameters/<X>/ RadioParametersContents	21
5.5.12 <X>/V2XoverPC5/NotServedByEUTRAN/RadioParameters/<X>/ GeographicalArea	21
5.5.13 <X>/V2XoverPC5/NotServedByEUTRAN/RadioParameters/<X>/ GeographicalArea/Polygon	21
5.5.14 <X>/V2XoverPC5/NotServedByEUTRAN/RadioParameters/<X>/ GeographicalArea/Polygon/<X>.....	21
5.5.15 <X>/V2XoverPC5/NotServedByEUTRAN/RadioParameters/<X>/ GeographicalArea/Polygon/<X>/Coordinates	22
5.5.16 <X>/V2XoverPC5/NotServedByEUTRAN/RadioParameters/<X>/ GeographicalArea/Polygon/<X>/Coordinates/<X>.....	22
5.5.17 <X>/V2XoverPC5/NotServedByEUTRAN/RadioParameters/<X>/ GeographicalArea/Polygon/<X>/Coordinates/<X>/Latitude	22
5.5.18 <X>/V2XoverPC5/NotServedByEUTRAN/RadioParameters/<X>/ GeographicalArea/Polygon/<X>/Coordinates/<X>/Longitude	22
5.5.19 <X>/V2XoverPC5/NotServedByEUTRAN/RadioParameters/<X>/ OperatorManaged.....	23
5.5.20 <X>/V2XoverPC5/AuthorizedV2XServiceList	23
5.5.21 <X>/V2XoverPC5/AuthorizedV2XServiceList/<X>	23
5.5.22 <X>/V2XoverPC5/AuthorizedV2XServiceList/<X>/ V2XServiceIdentifier	23
5.5.23 <X>/V2XoverPC5/AuthorizedV2XServiceList/<X>/ DestinationLayer2ID	23
5.5.24 <X>/V2XoverPC5/PPPPtoPDBMappingRule	24
5.5.25 <X>/V2XoverPC5/PPPPtoPDBMappingRule/<X>	24
5.5.26 <X>/V2XoverPC5/PPPPtoPDBMappingRule/<X>/ ProSePerPacketPriority.....	24
5.5.27 <X>/V2XoverPC5/PPPPtoPDBMappingRule/<X>/ PacketDelayBudget.....	24

5.5.27A	<X>/V2XoverPC5/DefaultDestinationLayer2ID	25
5.5.28	Void	25
5.5.29	<X>/V2XoverPC5/PrivacyConfig	25
5.5.30	<X>/V2XoverPC5/PrivacyConfig/TimerT5000	25
5.5.31	<X>/V2XoverPC5/PrivacyConfig/V2XServicePrivacyList	25
5.5.32	<X>/V2XoverPC5/PrivacyConfig/V2XServicePrivacyList/<X>	25
5.5.33	<X>/V2XoverPC5/PrivacyConfig/V2XServicePrivacyList/<X>/ V2XServiceIdentifier	26
5.5.34	<X>/V2XoverPC5/PrivacyConfig/V2XServicePrivacyList/<X>/ GeographicalAreaList	26
5.5.35	<X>/V2XoverPC5/PrivacyConfig/V2XServicePrivacyList/<X>/ GeographicalAreaList/<X>	26
5.5.36	<X>/V2XoverPC5/PrivacyConfig/V2XServicePrivacyList/<X>/ GeographicalAreaList/<X>/GeographicalArea	26
5.5.37	<X>/V2XoverPC5/PrivacyConfig/V2XServicePrivacyList/<X>/ GeographicalAreaList/<X>/GeographicalArea/Polygon	26
5.5.38	<X>/V2XoverPC5/V2XServiceIDtoV2XFrequencyMappingRule	26
5.5.39	<X>/V2XoverPC5/V2XServiceIDtoV2XFrequencyMappingRule/<X>	27
5.5.40	<X>/V2XoverPC5/V2XServiceIDtoV2XFrequencyMappingRule/<X>/ V2XServiceIdentifier	27
5.5.41	<X>/V2XoverPC5/V2XServiceIDtoV2XFrequencyMappingRule/<X>/ V2XFrequency	27
5.5.42	<X>/V2XoverPC5/V2XServiceIDtoV2XFrequencyMappingRule/<X>/ V2XFrequency/<X>	27
5.5.43	<X>/V2XoverPC5/V2XServiceIDtoV2XFrequencyMappingRule/<X>/ V2XFrequency/<X>/V2XFrequency	27
5.5.44	<X>/V2XoverPC5/V2XServiceIDtoV2XFrequencyMappingRule/<X>/ GeographicalArea	28
5.5.45	<X>/V2XoverPC5/V2XServiceIDtoV2XFrequencyMappingRule/<X>/ GeographicalArea/Polygon	28
5.5.46	<X>/V2XoverPC5/V2XServiceIDtoTxProfileMappingRule	28
5.5.47	<X>/V2XoverPC5/V2XServiceIDtoTxProfileMappingRule/<X>	28
5.5.48	<X>/V2XoverPC5/V2XServiceIDtoTxProfileMappingRule/<X>/ V2XServiceIdentifier	28
5.5.49	<X>/V2XoverPC5/V2XServiceIDtoTxProfileMappingRule/<X>/ TxProfile	28
5.5.50	<X>/V2XoverPC5/PPRAuthorizationList	29
5.5.51	<X>/V2XoverPC5/PPRAuthorizationList/<X>	29
5.5.52	<X>/V2XoverPC5/PPRAuthorizationList/<X>/V2XServiceIdentifier	29
5.5.53	<X>/V2XoverPC5/PPRAuthorizationList/<X>/PPPRValue	29
5.5A	Configuration parameters for V2X communication over NR-PC5	29
5.5A.1	<X>/V2XoverPC5/V2XoverNRPC5	29
5.5A.2	<X>/V2XoverPC5/V2XoverNRPC5/ V2XServiceIDtoV2XNRFrequencyMappingRule	30
5.5A.3	<X>/V2XoverPC5/V2XoverNRPC5/ V2XServiceIDtoV2XNRFrequencyMappingRule/<X>	30
5.5A.4	<X>/V2XoverPC5/V2XoverNRPC5/ V2XServiceIDtoV2XNRFrequencyMappingRule/<X>/ V2XServiceIdentifier	30
5.5A.5	<X>/V2XoverPC5/V2XoverNRPC5/ V2XServiceIDtoV2XNRFrequencyMappingRule/<X>/ V2XNRFrequency	30
5.5A.6	<X>/V2XoverPC5/V2XoverNRPC5/ V2XServiceIDtoV2XNRFrequencyMappingRule/<X>/ V2XNRFrequency/<X>	31
5.5A.7	<X>/V2XoverPC5/V2XoverNRPC5/ V2XServiceIDtoV2XNRFrequencyMappingRule/<X>/ V2XNRFrequency/<X>/V2XNRFrequency	31
5.5A.8	<X>/V2XoverPC5/V2XoverNRPC5/ V2XServiceIDtoV2XNRFrequencyMappingRule/<X>/ GeographicalArea	31
5.5A.9	<X>/V2XoverPC5/V2XoverNRPC5/ V2XServiceIDtoV2XNRFrequencyMappingRule/<X>/ GeographicalArea/Polygon	31
5.5A.10	<X>/V2XoverPC5/V2XoverNRPC5/ V2XServiceIDtoBroadcastDestinationLayer2IDMappingRule	31
5.5A.11	<X>/V2XoverPC5/V2XoverNRPC5/ V2XServiceIDtoBroadcastDestinationLayer2IDMappingRule/<X>	32
5.5A.12	<X>/V2XoverPC5/V2XoverNRPC5/ V2XServiceIDtoBroadcastDestinationLayer2IDMappingRule/<X>/ V2XServiceIdentifier	32
5.5A.13	<X>/V2XoverPC5/V2XoverNRPC5/ V2XServiceIDtoBroadcastDestinationLayer2IDMappingRule/<X>/ BroadcastDestinationlayer2ID	32
5.5A.14	<X>/V2XoverPC5/V2XoverNRPC5/ DefaultBroadcastDestinationLayer2ID	32
5.5A.15	<X>/V2XoverPC5/V2XoverNRPC5/ V2XServiceIDtoGroupcastDestinationLayer2IDMappingRule	33
5.5A.16	<X>/V2XoverPC5/V2XoverNRPC5/ V2XServiceIDtoGroupcastDestinationLayer2IDMappingRule/<X>	33
5.5A.17	<X>/V2XoverPC5/V2XoverNRPC5/ V2XServiceIDtoGroupcastDestinationLayer2IDMappingRule/<X>/ V2XServiceIdentifier	33
5.5A.18	<X>/V2XoverPC5/V2XoverNRPC5/ V2XServiceIDtoGroupcastDestinationLayer2IDMappingRule/<X>/ GroupcastDestinationlayer2ID	33

5.5.A.19	<X>/V2XoverPC5/V2XoverNRPC5/ V2XServiceIDtoUnicastInitialSignallingDestinationLayer2IDMappingRule.....	33
5.5.A.20	<X>/V2XoverPC5/V2XoverNRPC5/ V2XServiceIDtoUnicastInitialSignallingDestinationLayer2IDMappingRule/<X>	34
5.5.A.21	<X>/V2XoverPC5/V2XoverNRPC5/ V2XServiceIDtoUnicastInitialSignallingDestinationLayer2IDMappingRule/<X>/V2XServiceIdentif ier	34
5.5.A.22	<X>/V2XoverPC5/V2XoverNRPC5/ V2XServiceIDtoUnicastInitialSignallingDestinationLayer2IDMappingRule/<X>/UnicastInitialSign allingDestinationlayer2ID.....	34
5.5.A.23	<X>/V2XoverPC5/V2XoverNRPC5/ V2XServiceIDtoPC5QoSParametersMappingRule.....	34
5.5.A.24	<X>/V2XoverPC5/V2XoverNRPC5/ V2XServiceIDtoPC5QoSParametersMappingRule/<X>	35
5.5.A.25	<X>/V2XoverPC5/V2XoverNRPC5/ V2XServiceIDtoPC5QoSParametersMappingRule/<X>/ V2XServiceIdentifier.....	35
5.5.A.26	<X>/V2XoverPC5/V2XoverNRPC5/ V2XServiceIDtoPC5QoSParametersMappingRule/<X>/PQI.....	35
5.5.A.27	<X>/V2XoverPC5/V2XoverNRPC5/ V2XServiceIDtoPC5QoSParametersMappingRule/<X>/ GuaranteedFlowBitRate.....	35
5.5.A.28	<X>/V2XoverPC5/V2XoverNRPC5/ V2XServiceIDtoPC5QoSParametersMappingRule/<X>/ MaximumFlowBitRate	35
5.5.A.29	<X>/V2XoverPC5/V2XoverNRPC5/ V2XServiceIDtoPC5QoSParametersMappingRule/<X>/ PerLinkAggregateMaximumBitRate	36
5.5.A.30	<X>/V2XoverPC5/V2XoverNRPC5/ V2XServiceIDtoPC5QoSParametersMappingRule/<X>/Range....	36
5.5.A.31	<X>/V2XoverPC5/V2XoverNRPC5/ASConfiguration	36
5.5.A.32	<X>/V2XoverPC5/V2XoverNRPC5/ASConfiguration/ SLRBMappingRule.....	36
5.5.A.33	<X>/V2XoverPC5/V2XoverNRPC5/ASConfiguration/ SLRBMappingRule/<X>	37
5.5.A.34	<X>/V2XoverPC5/V2XoverNRPC5/ASConfiguration/ SLRBMappingRule/<X>/PC5QoSProfile	37
5.5.A.35	<X>/V2XoverPC5/V2XoverNRPC5/ASConfiguration/ SLRBMappingRule/<X>/PC5QoSProfile/PQI.....	37
5.5.A.36	<X>/V2XoverPC5/V2XoverNRPC5/ASConfiguration/ SLRBMappingRule/<X>/PC5QoSProfile/GuaranteedFlowBitRate	37
5.5.A.37	<X>/V2XoverPC5/V2XoverNRPC5/ASConfiguration/ SLRBMappingRule/<X>/PC5QoSProfile/MaximumFlowBitRate	37
5.5.A.38	<X>/V2XoverPC5/V2XoverNRPC5/ASConfiguration/ SLRBMappingRule/<X>/PC5QoSProfile/ PerLinkAggregateMaximumBitRate	37
5.5.A.39	<X>/V2XoverPC5/V2XoverNRPC5/ASConfiguration/ SLRBMappingRule/<X>/PC5QoSProfile/Range	37
5.5.A.40	<X>/V2XoverPC5/V2XoverNRPC5/ASConfiguration/ SLRBMappingRule/<X>/PC5QoSProfile/PriorityLevel.....	37
5.5.A.41	<X>/V2XoverPC5/V2XoverNRPC5/ASConfiguration/ SLRBMappingRule/<X>/PC5QoSProfile/AveragingWindow.....	38
5.5.A.42	<X>/V2XoverPC5/V2XoverNRPC5/ASConfiguration/ SLRBMappingRule/<X>/PC5QoSProfile/MaximumDataBurstVolume.....	38
5.5.A.43	<X>/V2XoverPC5/V2XoverNRPC5/ASConfiguration/ SLRBMappingRule/<X>/SLRB	38
5.5.A.44	<X>/V2XoverPC5/V2XoverNRPC5/ V2XServiceIDtoDefaultModeOfCommunicationMappingRule	38
5.5.A.45	<X>/V2XoverPC5/V2XoverNRPC5/ V2XServiceIDtoDefaultModeOfCommunicationMappingRule/<X>	39
5.5.A.46	<X>/V2XoverPC5/V2XoverNRPC5/ V2XServiceIDtoDefaultModeOfCommunicationMappingRule/<X>/ V2XServiceIdentifier.....	39
5.5.A.47	<X>/V2XoverPC5/V2XoverNRPC5/ V2XServiceIDtoDefaultModeOfCommunicationMappingRule/<X>/ DefaultModeOfCommunication	39
5.5.A.48	<X>/V2XoverPC5/V2XoverNRPC5/NRPC5UnicastSecurityPolicies.....	39
5.5.A.49	<X>/V2XoverPC5/V2XoverNRPC5/NRPC5UnicastSecurityPolicies/ <X>	39
5.5.A.50	<X>/V2XoverPC5/V2XoverNRPC5/NRPC5UnicastSecurityPolicies/ <X>/V2XServiceIdentifier.....	40
5.5.A.51	<X>/V2XoverPC5/V2XoverNRPC5/NRPC5UnicastSecurityPolicies/ <X>/SecurityPolicies	40
5.5.A.52	<X>/V2XoverPC5/V2XoverNRPC5/NRPC5UnicastSecurityPolicies/ <X>/SecurityPolicies/SignallingIntegrityProtectionPolicy	40
5.5.A.53	<X>/V2XoverPC5/V2XoverNRPC5/NRPC5UnicastSecurityPolicies/ <X>/SecurityPolicies/SignallingCipherringPolicy	40
5.5.A.54	<X>/V2XoverPC5/V2XoverNRPC5/NRPC5UnicastSecurityPolicies/ <X>/SecurityPolicies/UserPlaneIntegrityProtectionPolicy	40

5.5A.55	<X>/V2XoverPC5/V2XoverNRPC5/NRPC5UnicastSecurityPolicies/ <X>/SecurityPolicies/SignallingCipheringPolicy	41
5.5A.56	<X>/V2XoverPC5/V2XoverNRPC5/NRPC5UnicastSecurityPolicies/ <X>/GeographicalArea	41
5.5A.57	<X>/V2XoverPC5/V2XoverNRPC5/NRPC5UnicastSecurityPolicies/ <X>/GeographicalArea/Polygon	41
5.6	Configuration parameters for V2X communication over LTE-Uu.....	41
5.6.1	<X>/V2XoverLTEUu.....	41
5.6.2	<X>/V2XoverLTEUu/Expiration	42
5.6.3	<X>/V2XoverLTEUu/ToConRefs	42
5.6.4	<X>/V2XoverLTEUu/ToConRefs/<X>	42
5.6.5	<X>/V2XoverLTEUu/ToConRefs/<X>/ConRef	42
5.6.6	<X>/V2XoverLTEUu/AuthorizedPLMNs	42
5.6.7	<X>/V2XoverLTEUu/AuthorizedPLMNs/<X>	43
5.6.8	<X>/V2XoverLTEUu/AuthorizedPLMNs/<X>/PLMN.....	43
5.6.9	<X>/V2XoverLTEUu/AuthorizedPLMNs/<X>/V2XASMBMSConfig	43
5.6.10	<X>/V2XoverLTEUu/AuthorizedPLMNs/<X>/V2XASMBMSConfig/ TMGI.....	43
5.6.11	<X>/V2XoverLTEUu/AuthorizedPLMNs/<X>/V2XASMBMSConfig/ SAIList	44
5.6.12	<X>/V2XoverLTEUu/AuthorizedPLMNs/<X>/V2XASMBMSConfig/ SAIList/<X>	44
5.6.13	<X>/V2XoverLTEUu/AuthorizedPLMNs/<X>/V2XASMBMSConfig/ SAIList/<X>/SAI	44
5.6.14	<X>/V2XoverLTEUu/AuthorizedPLMNs/<X>/V2XASMBMSConfig/ Frequency	44
5.6.15	<X>/V2XoverLTEUu/AuthorizedPLMNs/<X>/V2XASMBMSConfig/ SDPInV2XASMBMSConfig.....	45
5.6.16	<X>/V2XoverLTEUu/AuthorizedPLMNs/<X>/ V2XServiceIdentifierUnrelated.....	45
5.6.17	<X>/V2XoverLTEUu/AuthorizedPLMNs/<X>/ V2XServiceIdentifierUnrelated/V2XMBMSConfigs.....	45
5.6.18	<X>/V2XoverLTEUu/AuthorizedPLMNs/<X>/ V2XServiceIdentifierUnrelated/V2XMBMSConfigs/<X>	46
5.6.19	<X>/V2XoverLTEUu/AuthorizedPLMNs/<X>/ V2XServiceIdentifierUnrelated/V2XMBMSConfigs/<X>/V2XMBMSConfig.....	46
5.6.20	<X>/V2XoverLTEUu/AuthorizedPLMNs/<X>/ V2XServiceIdentifierUnrelated/V2XMBMSConfigs/<X>/V2XMBMSConfig/TMGI	46
5.6.21	<X>/V2XoverLTEUu/AuthorizedPLMNs/<X>/ V2XServiceIdentifierUnrelated/V2XMBMSConfigs/<X>/V2XMBMSConfig/SAIList.....	46
5.6.22	<X>/V2XoverLTEUu/AuthorizedPLMNs/<X>/ V2XServiceIdentifierUnrelated/V2XMBMSConfigs/<X>/V2XMBMSConfig/SAIList/<X>	47
5.6.23	<X>/V2XoverLTEUu/AuthorizedPLMNs/<X>/ V2XServiceIdentifierUnrelated/V2XMBMSConfigs/<X>/V2XMBMSConfig/SAIList/<X>/SAI.....	47
5.6.24	<X>/V2XoverLTEUu/AuthorizedPLMNs/<X>/ V2XServiceIdentifierUnrelated/V2XMBMSConfigs/<X>/V2XMBMSConfig/Frequency.....	47
5.6.25	<X>/V2XoverLTEUu/AuthorizedPLMNs/<X>/ V2XServiceIdentifierUnrelated/V2XMBMSConfigs/<X>/V2XMBMSConfig/ SDPInV2XMBMSConfig.....	47
5.6.26	<X>/V2XoverLTEUu/AuthorizedPLMNs/<X>/ V2XServiceIdentifierUnrelated/V2XASAddresses.....	48
5.6.27	<X>/V2XoverLTEUu/AuthorizedPLMNs/<X>/ V2XServiceIdentifierUnrelated/V2XASAddress/<X>	48
5.6.28	<X>/V2XoverLTEUu/AuthorizedPLMNs/<X>/ V2XServiceIdentifierUnrelated/V2XASAddress/<X>/L3Address	48
5.6.29	<X>/V2XoverLTEUu/AuthorizedPLMNs/<X>/ V2XServiceIdentifierUnrelated/V2XASAddress/<X>/UDPPort	48
5.6.30	<X>/V2XoverLTEUu/AuthorizedPLMNs/<X>/ V2XServiceIdentifierUnrelated/V2XASAddress/<X>/ GeographicalArea.....	49
5.6.31	<X>/V2XoverLTEUu/AuthorizedPLMNs/<X>/ V2XServiceIdentifierUnrelated/V2XASAddress/<X>/GeographicalArea/Polygon	49
5.6.32	<X>/V2XoverLTEUu/AuthorizedPLMNs/<X>/ V2XServiceIdentifierRelated	49
5.6.33	<X>/V2XoverLTEUu/AuthorizedPLMNs/<X>/ V2XServiceIdentifierRelated/AuthorizedV2XServiceList.....	49
5.6.34	<X>/V2XoverLTEUu/AuthorizedPLMNs/<X>/ V2XServiceIdentifierRelated/AuthorizedV2XServiceList/<X>	50
5.6.35	<X>/V2XoverLTEUu/AuthorizedPLMNs/<X>/ V2XServiceIdentifierRelated/AuthorizedV2XServiceList/<X>/ V2XServiceIdentifier	50
5.6.36	<X>/V2XoverLTEUu/AuthorizedPLMNs/<X>/ V2XServiceIdentifierRelated/AuthorizedV2XServiceList/<X>/ V2XMBMSConfigs.....	50

5.6.37	<X>/V2XoverLTEUu/AuthorizedPLMNs/<X>/ V2XServiceIdentifierRelated/AuthorizedV2XServiceList/<X>/ V2XMBMSConfigs/<X>.....	51
5.6.38	<X>/V2XoverLTEUu/AuthorizedPLMNs/<X>/ V2XServiceIdentifierRelated/AuthorizedV2XServiceList/<X>/V2XMBMSConfigs/<X>/ V2XMBMSConfig	51
5.6.39	<X>/V2XoverLTEUu/AuthorizedPLMNs/<X>/ V2XServiceIdentifierRelated/AuthorizedV2XServiceList/<X>/V2XMBMSConfigs/<X>/ V2XMBMSConfig/TMGI	51
5.6.40	<X>/V2XoverLTEUu/AuthorizedPLMNs/<X>/ V2XServiceIdentifierRelated/AuthorizedV2XServiceList/<X>/V2XMBMSConfigs/<X>/ V2XMBMSConfig/SAIList.....	51
5.6.41	<X>/V2XoverLTEUu/AuthorizedPLMNs/<X>/ V2XServiceIdentifierRelated/AuthorizedV2XServiceList/<X>/V2XMBMSConfigs/<X>/ V2XMBMSConfig/SAIList/<X>	52
5.6.42	<X>/V2XoverLTEUu/AuthorizedPLMNs/<X>/ V2XServiceIdentifierRelated/AuthorizedV2XServiceList/<X>/V2XMBMSConfigs/<X>/ V2XMBMSConfig/SAIList/<X>/SAI.....	52
5.6.43	<X>/V2XoverLTEUu/AuthorizedPLMNs/<X>/ V2XServiceIdentifierRelated/AuthorizedV2XServiceList/<X>/V2XMBMSConfigs/<X>/ V2XMBMSConfig/Frequency.....	52
5.6.44	<X>/V2XoverLTEUu/AuthorizedPLMNs/<X>/ V2XServiceIdentifierRelated/AuthorizedV2XServiceList/<X>/V2XMBMSConfigs/<X>/ V2XMBMSConfig/SDPInV2XMBMSConfig	53
5.6.45	<X>/V2XoverLTEUu/AuthorizedPLMNs/<X>/ V2XServiceIdentifierRelated/AuthorizedV2XServiceList/<X>/ V2XASAddresses	53
5.6.45A	<X>/V2XoverLTEUu/AuthorizedPLMNs/<X>/ V2XServiceIdentifierRelated/AuthorizedV2XServiceList/<X>/ V2XASTCPAddresses	53
5.6.45B	<X>/V2XoverLTEUu/AuthorizedPLMNs/<X>/ V2XServiceIdentifierRelated/AuthorizedV2XServiceList/<X>/ V2XASTCPAddresses/<X>.....	53
5.6.45C	<X>/V2XoverLTEUu/AuthorizedPLMNs/<X>/ V2XServiceIdentifierRelated/AuthorizedV2XServiceList/<X>/ V2XASTCPAddresses/<X>/L3Address	54
5.6.45D	<X>/V2XoverLTEUu/AuthorizedPLMNs/<X>/ V2XServiceIdentifierUnrelated/V2XASTCPAddress/<X>/TCPPort	54
5.6.45E	<X>/V2XoverLTEUu/AuthorizedPLMNs/<X>/ V2XServiceIdentifierUnrelated/V2XASTCPAddress/<X>/ GeographicalArea	54
5.6.46	<X>/V2XoverLTEUu/AuthorizedPLMNs/<X>/ V2XServiceIdentifierRelated/DefaultV2XMBMSConfigs	54
5.6.47	<X>/V2XoverLTEUu/AuthorizedPLMNs/<X>/ V2XServiceIdentifierRelated/DefaultV2XMBMSConfigs/<X>	54
5.6.48	<X>/V2XoverLTEUu/AuthorizedPLMNs/<X>/ V2XServiceIdentifierRelated/DefaultV2XMBMSConfigs/<X>/ V2XMBMSConfig	55
5.6.49	<X>/V2XoverLTEUu/AuthorizedPLMNs/<X>/ V2XServiceIdentifierRelated/DefaultV2XMBMSConfigs/<X>/ V2XMBMSConfig/TMGI	55
5.6.50	<X>/V2XoverLTEUu/AuthorizedPLMNs/<X>/ V2XServiceIdentifierRelated/DefaultV2XMBMSConfigs/<X>/ V2XMBMSConfig/SAIList.....	55
5.6.51	<X>/V2XoverLTEUu/AuthorizedPLMNs/<X>/ V2XServiceIdentifierRelated/DefaultV2XMBMSConfigs/<X>/ V2XMBMSConfig/SAIList/<X>	55
5.6.52	<X>/V2XoverLTEUu/AuthorizedPLMNs/<X>/ V2XServiceIdentifierRelated/DefaultV2XMBMSConfigs/<X>/ V2XMBMSConfig/SAIList/<X>/SAI.....	56
5.6.53	<X>/V2XoverLTEUu/AuthorizedPLMNs/<X>/ V2XServiceIdentifierRelated/DefaultV2XMBMSConfigs/<X>/ V2XMBMSConfig/Frequency	56
5.6.54	<X>/V2XoverLTEUu/AuthorizedPLMNs/<X>/ V2XServiceIdentifierRelated/DefaultV2XMBMSConfigs/<X>/ V2XMBMSConfig/SDPInV2XMBMSConfig	56
5.6.55	<X>/V2XoverLTEUu/AuthorizedPLMNs/<X>/ V2XServiceIdentifierRelated/ DefaultV2XASAddresses	56
5.6.56	<X>/V2XoverLTEUu/AuthorizedPLMNs/<X>/ V2XServiceIdentifierRelated/ DefaultV2XASAddresses/<X>.....	57
5.6.57	<X>/V2XoverLTEUu/AuthorizedPLMNs/<X>/ V2XServiceIdentifierRelated/ DefaultV2XASAddresses/<X>/TypeOfData.....	57

5.6.58	<X>/V2XoverLTEUu/AuthorizedPLMNs/<X>/ V2XServiceIdentifierRelated/ DefaultV2XASAddresses/<X>/V2XMessageFamily	57
5.6.59	<X>/V2XoverLTEUu/AuthorizedPLMNs/<X>/ V2XServiceIdentifierRelated/DefaultV2XASAddresses/<X>/ V2XASAddresses	57
5.6.60	<X>/V2XoverLTEUu/AuthorizedPLMNs/<X>/ V2XServiceIdentifierRelated/IPUicastRoutingV2XServiceList	58
5.6.61	<X>/V2XoverLTEUu/AuthorizedPLMNs/<X>/ V2XServiceIdentifierRelated/IPUicastRoutingV2XServiceList/<X>	58
5.6.62	<X>/V2XoverLTEUu/AuthorizedPLMNs/<X>/ V2XServiceIdentifierRelated/IPUicastRoutingV2XServiceList/<X> V2XServiceIdentifier	58
5.7	<X>/Ext	58
Annex A (informative):	V2X Communication Provisioning MO DDF	59
Annex B (informative):	Change history	124
History		125

Foreword

This Technical Report has been produced by the 3rd Generation Partnership Project (3GPP).

The contents of the present document are subject to continuing work within the TSG and may change following formal TSG approval. Should the TSG modify the contents of the present document, it will be re-released by the TSG with an identifying change of release date and an increase in version number as follows:

Version x.y.z

where:

- x the first digit:
 - 1 presented to TSG for information;
 - 2 presented to TSG for approval;
 - 3 or greater indicates TSG approved document under change control.
- y the second digit is incremented for all changes of substance, i.e. technical enhancements, corrections, updates, etc.
- z the third digit is incremented when editorial only changes have been incorporated in the document.

1 Scope

The present document defines Management Object (MO) that is used to configure the UE for V2X services.

The MO is compatible with the OMA Device Management (DM) protocol specifications, version 1.2 and upwards, and is defined using the OMA DM Device Description Framework (DDF) as described in the Enabler Release Definition OMA-ERELED-DM-V1_2 [3].

The MO consists of relevant parameters for provisioning and authorization of V2X communication at the UE.

The protocol aspects for V2X are described in 3GPP TS 24.386 [4].

2 References

The following documents contain provisions which, through reference in this text, constitute provisions of the present document.

- References are either specific (identified by date of publication, edition number, version number, etc.) or non-specific.
- For a specific reference, subsequent revisions do not apply.
- For a non-specific reference, the latest version applies. In the case of a reference to a 3GPP document (including a GSM document), a non-specific reference implicitly refers to the latest version of that document *in the same Release as the present document*.

- [1] 3GPP TR 21.905: "Vocabulary for 3GPP Specifications".
- [2] 3GPP TS 23.285: "Architecture enhancements for V2X services".
- [3] OMA-ERELED-DM-V1_2: "Enabler Release Definition for OMA Device Management".
- [4] 3GPP TS 24.386: "User Equipment (UE) to V2X control function; protocol aspects; Stage 3".
- [5] OMA-TS-DM_Protocol-V1_2: "OMA Device Management Protocol".
- [6] ISO 8601:2004: "Data elements and interchange formats -- Information interchange -- Representation of dates and times".
- [7] 3GPP TS 23.003: "Numbering, addressing and identification".
- [8] 3GPP TS 36.331: "Evolved Universal Terrestrial Radio Access (E-UTRA); Radio Resource Control (RRC) protocol specification".
- [9] 3GPP TS 23.032: "Universal Geographical Area Description (GAD)".
- [10] ISO TS 17419 ITS-AID AssignedNumbers :
<http://standards.iso.org/iso/ts/17419/TS17419%20Assigned%20Numbers/TS17419 ITS-AID AssignedNumbers.pdf>
- [11] 3GPP TS 36.101: "Evolved Universal Terrestrial Radio Access (E-UTRA); User Equipment (UE) radio transmission and reception".
- [12] 3GPP TS 23.303: "Proximity-based Services (ProSe); Stage 2".
- [13] 3GPP TS 36.300: "Evolved Universal Terrestrial Radio Access (E-UTRA) and Evolved Universal Terrestrial Radio Access (E-UTRAN); Overall description; Stage 2".
- [14] OMA-DDS-DM_ConnMO-V1_0-20081107-A: "Standardized Connectivity Management Objects".
- [15] 3GPP TS 38.331: "NR; Radio Resource Control (RRC) protocol specification".
- [16] 3GPP TS 38.300: "NR; NR and NG-RAN Overall Description; Stage 2".

- [17] 3GPP TS 23.287: "Architecture enhancements for 5G System (5GS) to support; Vehicle-to-Everything (V2X) services".
- [18] 3GPP TS 24.588: "Evolved Universal Terrestrial Radio Access (E-UTRA) and Evolved Universal Terrestrial Radio Access (E-UTRAN); Overall description; Stage 2".

3 Definitions and abbreviations

3.1 Definitions

For the purposes of the present document, the terms and definitions given in 3GPP TR 21.905 [1] and the following apply.

A term defined in the present document takes precedence over the definition of the same term, if any, in 3GPP TR 21.905 [1].

For the purposes of the present document, the following terms and definitions given in 3GPP TS 23.003 [7] apply:

TMGI

For the purposes of the present document, the following terms and definitions given in 3GPP TS 24.386 [4] apply:

Not served by E-UTRAN for V2X communication

3.2 Abbreviations

For the purposes of the present document, the abbreviations given in 3GPP TR 21.905 [1] and the following apply. An abbreviation defined in the present document takes precedence over the definition of the same abbreviation, if any, in 3GPP TR 21.905 [1].

DDF	Device Description Framework
MO	Management Object
PDB	Packet Delay Budget
PPPP	ProSe Per-Packet Priority
SAI	Service Area Identifier
SDP	Session Description Protocol
V2X	Vehicle-to-Everything

4 V2X Communication Provisioning MO

4.1 Overview

The V2X communication provisioning MO is used to manage the V2X configuration parameters in a UE supporting 3GPP TS 24.386 [4].

The MO identifier is: urn:oma:mo:ext-3gpp-V2X-communication-provisioning:1.0.

The OMA DM access control list (ACL) property mechanism (see OMA-ERELD-DM-V1_2 [3]) can be used to grant or deny access rights to OMA DM servers in order to modify nodes of the V2X communication provisioning MO.

In order to request provisioning of the V2X communication provisioning MO, the UE includes in the Package 1 (see OMA-TS-DM_Protocol-V1_2 [5]) a Generic Alert message (along with other commands):

- with the "Type" element set to "urn:oma:mo:ext-3gpp-V2X-communication-provisioning:1.0";
- with the "LocURI" element (inside the "Source" element) set to the address of the V2X communication provisioning MO as specified by OMA-TS-DM_Protocol-V1_2 [5]; and
- without the "Data" element.

The V2X communication provisioning MO consists of the nodes described in figure 4.1-1.

NOTE: In this release of the document, charging configuration parameters in the V2X communication provisioning MO are not specified.

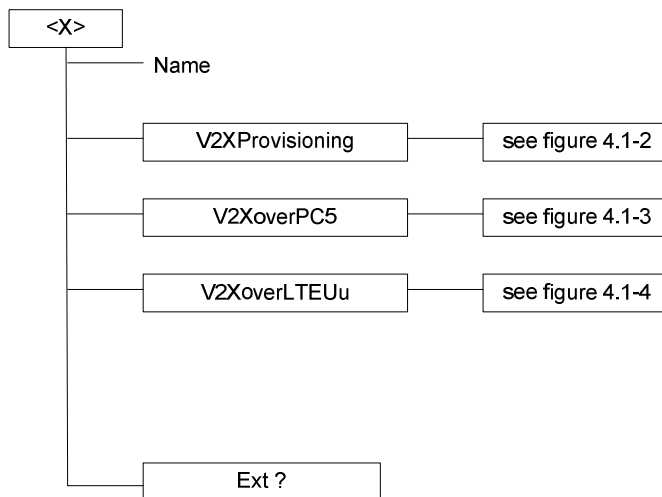

Figure 4.1-1: The V2X communication provisioning MO (part 1)

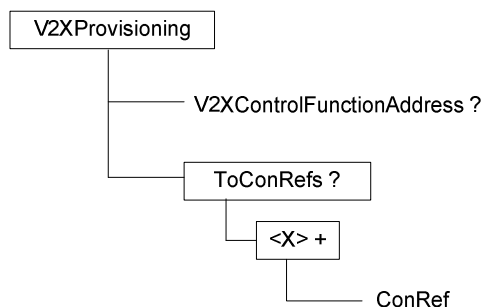

Figure 4.1-2: The V2X communication provisioning MO (part 2)

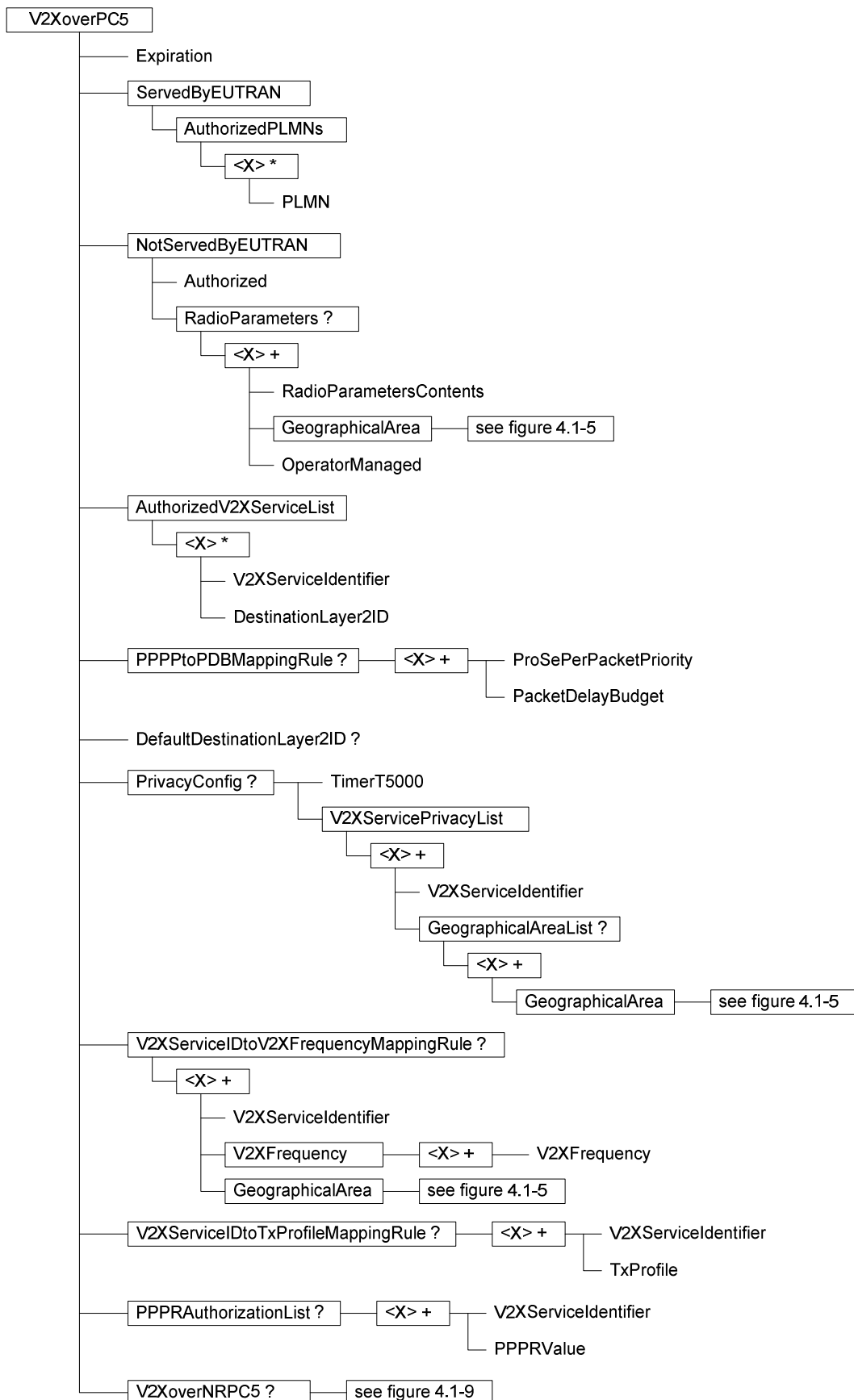

Figure 4.1-3: The V2X communication provisioning MO (part 3)

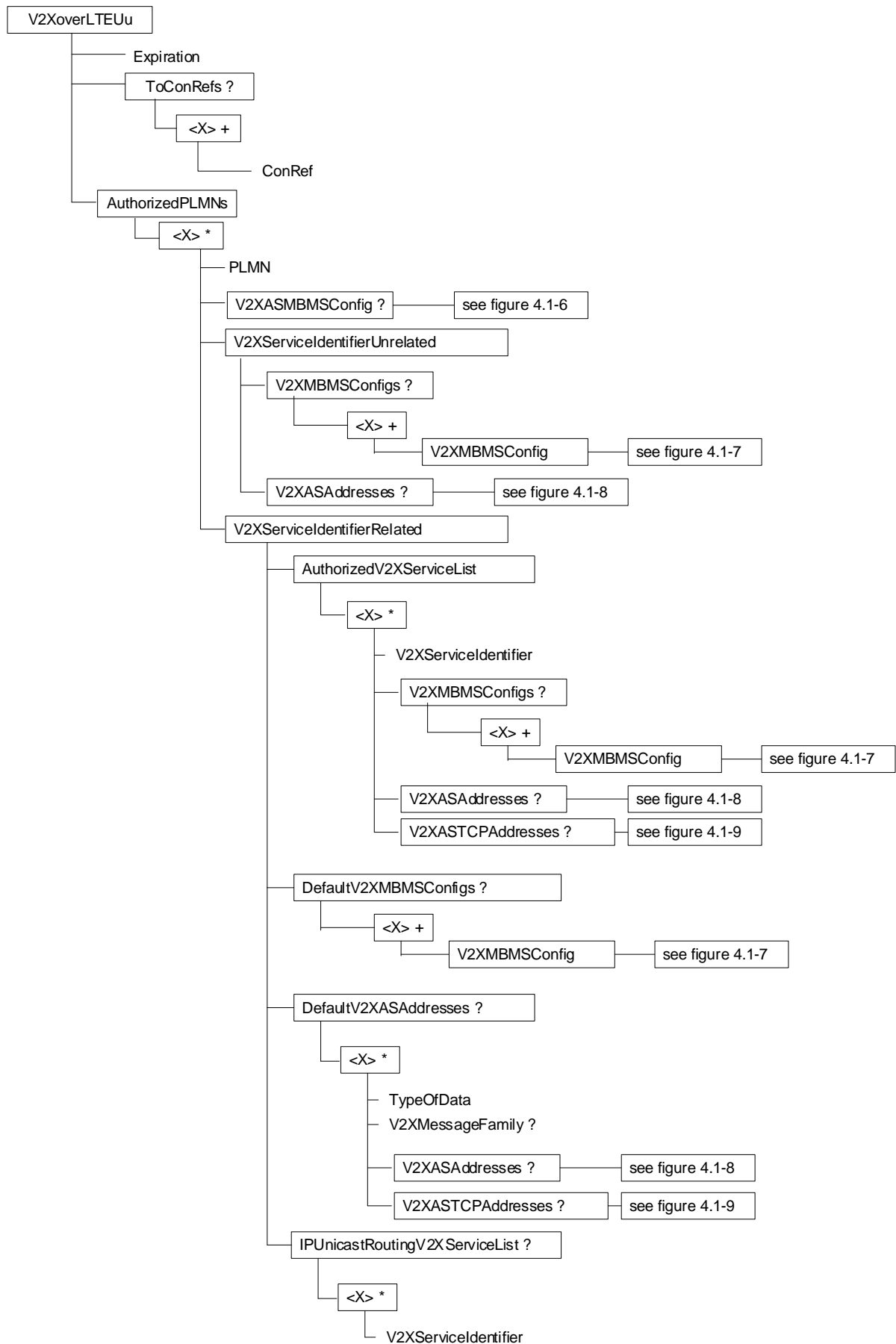

Figure 4.1-4: The V2X communication provisioning MO (part 4)

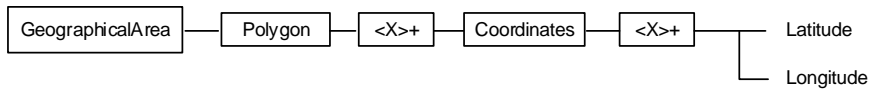

Figure 4.1-5: The V2X communication provisioning MO (part 5)

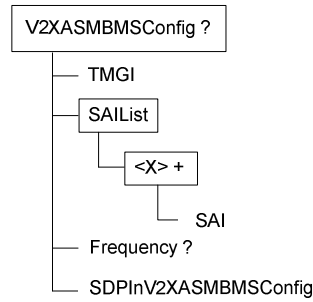

Figure 4.1-6: The V2X communication provisioning MO (part 6)

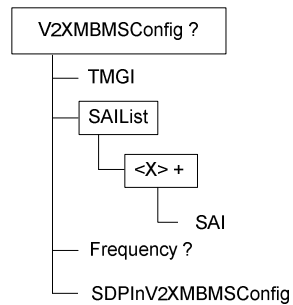

Figure 4.1-7: The V2X communication provisioning MO (part 7)

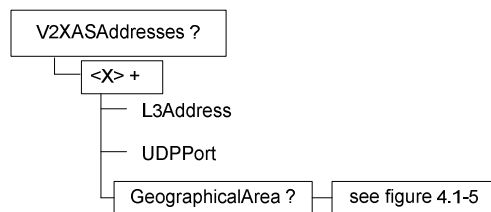

Figure 4.1-8: The V2X communication provisioning MO (part 8)

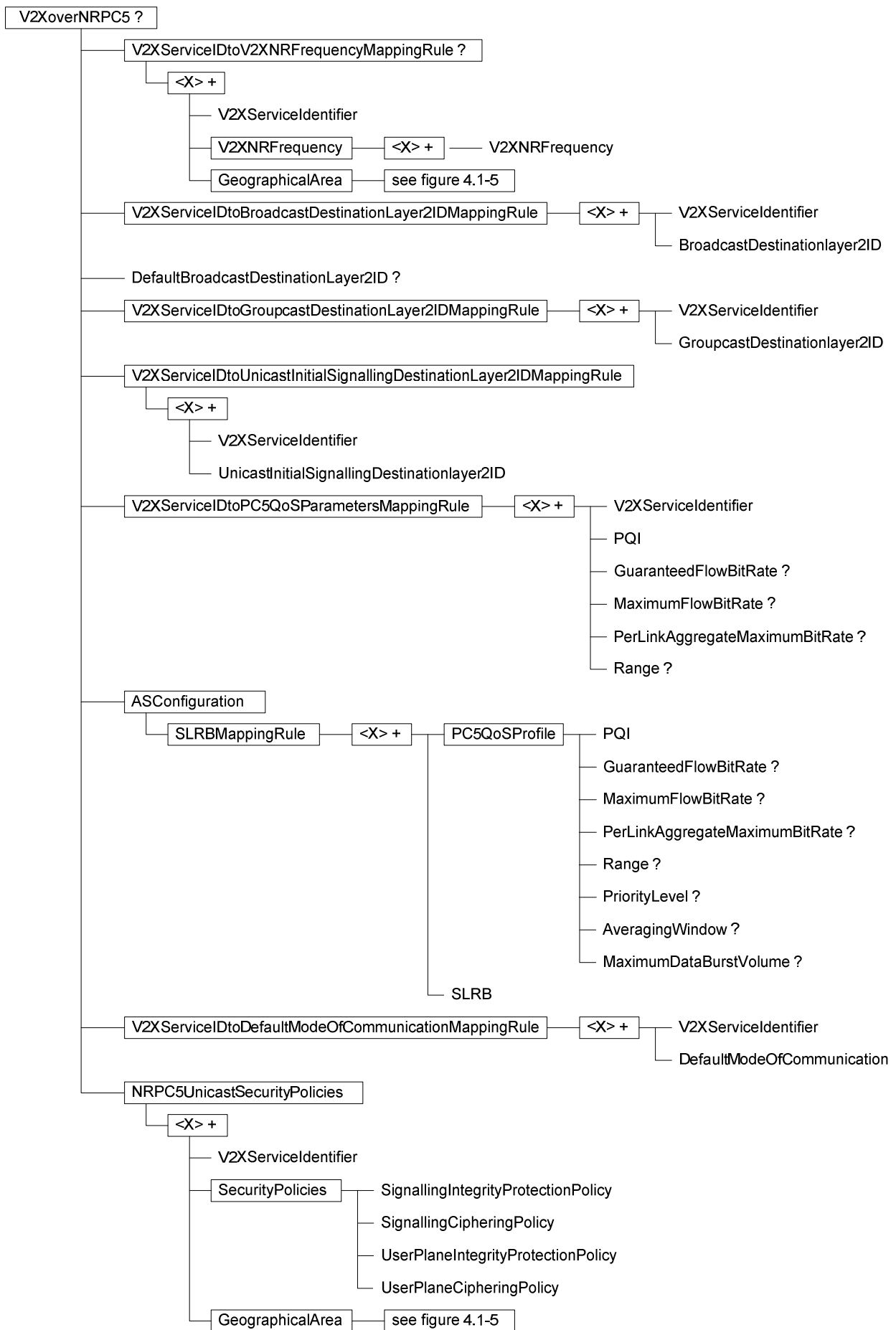

Figure 4.1-9: The V2X communication provisioning MO (part 9)

5 MO configuration parameters

5.1 General

This clause describes the configuration parameters of the V2X communication provisioning MO.

5.2 Node: <X>

This node acts as a placeholder for one or more accounts for a fixed node.

- Occurrence: OneOrMore
- Format: node
- Access Types: Get, Replace
- Values: N/A

This node is mandatory if the UE supports the UE role specified in 3GPP TS 24.386 [4].

NOTE: One node is normally used. More nodes are only used in case the terminal supports multiple UICCs.

5.3 <X>/Name

This node contains a name for the V2X configuration parameters.

- Occurrence: One
- Format: chr
- Access Types: Get, Replace
- Values: <User displayable name>

5.4 Configuration parameters for V2X provisioning

5.4.1 <X>/V2XProvisioning

The V2XProvisioning node contains the configuration parameters for V2X provisioning.

- Occurrence: One
- Format: node
- Access Types: Get, Replace
- Values: N/A

5.4.2 <X>/V2XProvisioning/V2XControlFunctionAddress

The V2XControlFunctionAddress leaf indicates the V2X control function address.

- Occurrence: ZeroOrOne
- Format: chr

- Access Types: Get, Replace
- Values: an FQDN or an IP address

5.4.3 <X>/V2XProvisioning/ToConRefs

The ToConRefs node is used to allow application to refer to a collection of connectivity definitions. Several connectivity parameters can be listed for a given application under this node.

This node contains configuration parameters for establishment of the PDN connection for reaching the V2X control function.

- Occurrence: ZeroOrOne
- Format: node
- Access Types: Get, Replace
- Values: N/A

5.4.4 <X>/V2XProvisioning/ToConRefs/<X>

This run-time node acts as a placeholder for each reference to connectivity parameters.

- Occurrence: OneOrMore
- Format: node
- Access Types: Get, Replace
- Values: N/A

5.4.5 <X>/V2XProvisioning/ToConRefs/<X>/ConRef

The ConRef leaf indicates a specific linkage to connectivity parameters.

- Occurrence: One
- Format: chr
- Access Types: Get, Replace
- Values: <A network access point object as defined in OMA-DDS-DM_ConnMO [14]>

5.5 Configuration parameters for V2X communication over PC5

5.5.1 <X>/V2XoverPC5

The V2XoverPC5 node contains the configuration parameters for V2X communication over PC5.

- Occurrence: One
- Format: node
- Access Types: Get, Replace
- Values: N/A

5.5.2 <X>/V2XoverPC5/Expiration

The Expiration leaf indicates the expiration time of validity of the configuration parameters for V2X communication over PC5.

- Occurrence: One
- Format: int
- Access Types: Get, Replace
- Values: a 40 bits unsigned integer value indicating a UTC time, in seconds since midnight UTC of January 1, 1970 (not counting leap seconds).

5.5.3 <X>/V2XoverPC5/ServedByEUTRAN

The ServedByEUTRAN node contains the configuration parameters for V2X communication over PC5 when the UE is served by E-UTRAN for V2X communication.

- Occurrence: One
- Format: node
- Access Types: Get, Replace
- Values: N/A

5.5.4 <X>/V2XoverPC5/ServedByEUTRAN/AuthorizedPLMNs

The AuthorizedPLMNs node contains a list of PLMNs in which the UE is authorized to use V2X communication over PC5 when the UE is served by E-UTRAN for V2X communication.

- Occurrence: One
- Format: node
- Access Types: Get, Replace
- Values: N/A

5.5.5 <X>/V2XoverPC5/ServedByEUTRAN/AuthorizedPLMNs/<X>

This node acts as a placeholder for a PLMN in which the UE is authorized to use V2X communication over PC5 when the UE is served by E-UTRAN for V2X communication.

- Occurrence: ZeroOrMore
- Format: node
- Access Types: Get, Replace
- Values: N/A

5.5.6 <X>/V2XoverPC5/ServedByEUTRAN/AuthorizedPLMNs/<X>/PLMN

The PLMN leaf indicates a PLMN code of a PLMN in which the UE is authorized to use V2X communication over PC5 when the UE is served by E-UTRAN for V2X communication.

- Occurrence: One
- Format: chr
- Access Types: Get, Replace
- Values: <PLMN code>

The format of the PLMN code is defined by 3GPP TS 23.003 [7].

5.5.7 <X>/V2XoverPC5/NotServedByEUTRAN

The NotServedByEUTRAN node contains the configuration parameters for V2X communication over PC5 when the UE is not served by E-UTRAN for V2X communication.

- Occurrence: One
- Format: node
- Access Types: Get, Replace
- Values: N/A

5.5.8 <X>/V2XoverPC5/NotServedByEUTRAN/Authorized

The Authorized leaf indicates whether the UE is authorized to use V2X communication over PC5 when the UE is not served by E-UTRAN for V2X communication.

- Occurrence: One
 - Format: bool
 - Access Types: Get, Replace
 - Values: 0, 1
- 0 Indicates that the UE is not authorized to use V2X communication over PC5 when the UE is not served by E-UTRAN for V2X communication.
- 1 Indicates that the UE is authorized to use V2X communication over PC5 when the UE is not served by E-UTRAN for V2X communication.

5.5.9 <X>/V2XoverPC5/NotServedByEUTRAN/RadioParameters

The RadioParameters node contains sets of radio parameters for V2X communication over PC5 applicable when the UE is not served by E-UTRAN for V2X communication and is located in a geographical area.

- Occurrence: ZeroOrOne
- Format: node
- Access Types: Get, Replace
- Values: N/A

5.5.10 <X>/V2XoverPC5/NotServedByEUTRAN/RadioParameters/<X>

This node acts as a placeholder for one set of radio parameters for V2X communication over PC5 applicable when the UE is not served by E-UTRAN for V2X communication and is located in a given geographical area.

- Occurrence: OneOrMore
- Format: node
- Access Types: Get, Replace
- Values: N/A

The radio parameters indicated in the RadioParametersContents child node apply for V2X communication over PC5 when the UE is not served by E-UTRAN for V2X communication and is located in geographical area indicated by the GeographicalArea child node.

5.5.11 <X>/V2XoverPC5/NotServedByEUTRAN/RadioParameters/<X>/RadioParametersContents

The RadioParametersContents leaf indicates the radio parameters for V2X communication over PC5.

- Occurrence: One
- Format: bin
- Access Types: Get, Replace
- Values: <RadioParametersContents>

The RadioParameterContents is defined as *SL-V2X-Preconfiguration* in clause 9 of 3GPP TS 36.331 [8].

5.5.12 <X>/V2XoverPC5/NotServedByEUTRAN/RadioParameters/<X>/GeographicalArea

The GeographicalArea node contains a geographical area description.

- Occurrence: One
- Format: node
- Access Types: Get, Replace
- Values: N/A

The UE is located in geographical area indicated by this node, if the UE is located in geographical area indicated by the Polygon child node.

5.5.13 <X>/V2XoverPC5/NotServedByEUTRAN/RadioParameters/<X>/GeographicalArea/Polygon

The Polygon node contains polygon geographical area descriptions.

- Occurrence: One
- Format: node
- Access Types: Get, Replace
- Values: N/A

The UE is located in geographical area indicated by this node, if the UE is located in polygon geographical area indicated by at least one child node.

5.5.14 <X>/V2XoverPC5/NotServedByEUTRAN/RadioParameters/<X>/GeographicalArea/Polygon/<X>

This node acts as a placeholder for a polygon geographical area description.

- Occurrence: OneOrMore
- Format: node
- Access Types: Get, Replace
- Values: N/A

The UE is located in polygon geographical area indicated by this node, if the UE is located inside a polygon described by the Coordinates child node.

5.5.15 <X>/V2XoverPC5/NotServedByEUTRAN/RadioParameters/<X>/GeographicalArea/Polygon/<X>/Coordinates

The Coordinates node contains coordinates of a polygon geographical area description.

- Occurrence: One
- Format: node
- Access Types: Get, Replace
- Values: N/A

The UE is located inside a polygon described by this node, if the UE is located in a polygon outlines of which are formed by coordinates indicated by the child nodes.

5.5.16 <X>/V2XoverPC5/NotServedByEUTRAN/RadioParameters/<X>/GeographicalArea/Polygon/<X>/Coordinates/<X>

This node acts as a placeholder for a coordinate.

- Occurrence: OneOrMore
- Format: node
- Access Types: Get, Replace
- Values: N/A

NOTE: The upper limit of 15 specified in 3GPP TS 23.032 [9] for the number of points in a polygon shape does not apply to the number of coordinates in a geographical area described as a polygon for V2X communication over PC5.

5.5.17 <X>/V2XoverPC5/NotServedByEUTRAN/RadioParameters/<X>/GeographicalArea/Polygon/<X>/Coordinates/<X>/Latitude

The Latitude leaf indicates a latitude of a coordinate.

- Occurrence: One
- Format: bin
- Access Types: Get, Replace
- Values: <Latitude>

The latitude is defined in subclause 6.1 of 3GPP TS 23.032 [9].

5.5.18 <X>/V2XoverPC5/NotServedByEUTRAN/RadioParameters/<X>/GeographicalArea/Polygon/<X>/Coordinates/<X>/Longitude

The Longitude leaf indicates a longitude of a coordinate.

- Occurrence: One
- Format: bin
- Access Types: Get, Replace
- Values: <Longitude>

The longitude is defined in subclause 6.1 of 3GPP TS 23.032 [9].

5.5.19 <X>/V2XoverPC5/NotServedByEUTRAN/RadioParameters/<X>/OperatorManaged

The OperatorManaged leaf indicates whether the radio parameters are "operator managed" or "non-operator managed".

- Occurrence: One
- Format: bool
- Access Types: Get, Replace
- Values: 0, 1
 - 0 Indicates that the radio parameters are "non-operator managed".
 - 1 Indicates that the radio parameters are "operator managed".

5.5.20 <X>/V2XoverPC5/AuthorizedV2XServiceList

The AuthorizedV2XServiceList node contains V2X services authorized for V2X communication over PC5.

- Occurrence: One
- Format: node
- Access Types: Get, Replace
- Values: N/A

5.5.21 <X>/V2XoverPC5/AuthorizedV2XServiceList/<X>

This node acts as a placeholder for a V2X service authorized for V2X communication over PC5.

- Occurrence: ZeroOrMore
- Format: node
- Access Types: Get, Replace
- Values: N/A

The DestinationLayer2ID child node contains the layer 2 ID for V2X communication over PC5 to be used for V2X messages of V2X service with V2X service identified indicated by the V2XServiceIdentifier child node.

5.5.22 <X>/V2XoverPC5/AuthorizedV2XServiceList/<X>/V2XServiceIdentifier

The V2XServiceIdentifier leaf indicates a V2X service identifier.

- Occurrence: One
- Format: int
- Access Types: Get, Replace
- Values: an integer between 0 and 4294967295.

V2X service identifiers are listed in ISO TS 17419 ITS-AID AssignedNumbers [10].

5.5.23 <X>/V2XoverPC5/AuthorizedV2XServiceList/<X>/DestinationLayer2ID

The DestinationLayer2ID leaf indicates a layer 2 ID for V2X communication over PC5.

- Occurrence: One
- Format: bin
- Access Types: Get, Replace
- Values: layer 2 identifier

The format of the DestinationLayer2ID is defined by 3GPP TS 36.300 [13].

5.5.24 <X>/V2XoverPC5/PPPPtoPDBMappingRule

The PPPPtoPDBMappingRule node contains the mapping rules between the ProSe Per-Packet Priority (PPPP) and Packet Delay Budget (PDB) for V2X communication over the PC5.

- Occurrence: ZeroOrOne
- Format: node
- Access Types: Get, Replace
- Values: N/A

5.5.25 <X>/V2XoverPC5/PPPPtoPDBMappingRule/<X>

This interior node acts as a placeholder for one or more mapping rules for V2X communication over the PC5.

- Occurrence: OneOrMore
- Format: node
- Access Types: Get, Replace
- Values: N/A

5.5.26 <X>/V2XoverPC5/PPPPtoPDBMappingRule/<X>/ ProSePerPacketPriority

The ProSePerPacketPriority leaf indicates the ProSe Per-Packet Priority value (as specified in 3GPP TS 23.303 [12]) configured by the mapping rule.

- Occurrence: One
- Format: int
- Access Types: Get, Replace
- Values: 1-8

5.5.27 <X>/V2XoverPC5/PPPPtoPDBMappingRule/<X>/ PacketDelayBudget

The PacketDelayBudget leaf indicates the Packet Delay Budget value in milliseconds to which the ProSe Per-Packet Priority value associated to the same mapping rule is mapped.

- Occurrence: One
- Format: int
- Access Types: Get, Replace
- Values: 1-65535

5.5.27A <X>/V2XoverPC5/DefaultDestinationLayer2ID

The DefaultDestinationLayer2ID leaf indicates a default destination Layer-2 ID for V2X communication over PC5.

- Occurrence: ZeroOrOne
- Format: bin
- Access Types: Get, Replace
- Values: layer 2 identifier

5.5.28 Void

5.5.29 <X>/V2XoverPC5/PrivacyConfig

The PrivacyConfig node contains the configuration parameters for privacy of V2X communication over PC5.

- Occurrence: ZeroOrOne
- Format: node
- Access Types: Get, Replace
- Values: N/A

5.5.30 <X>/V2XoverPC5/PrivacyConfig/TimerT5000

The TimerT5000 leaf indicates the duration, in units of seconds, after which the UE shall change the source Layer-2 ID and source IP address (for IP data) self-assigned by the UE while performing transmission of V2X communication over the PC5 when privacy is required.

- Occurrence: One
- Format: int
- Access Types: Get, Replace
- Values: 1-65535

5.5.31 <X>/V2XoverPC5/PrivacyConfig/V2XServicePrivacyList

The V2XServicePrivacyList node contains the V2X service identifiers of the V2X services which require privacy for V2X communication over PC5.

- Occurrence: One
- Format: node
- Access Types: Get, Replace
- Values: N/A

5.5.32 <X>/V2XoverPC5/PrivacyConfig/V2XServicePrivacyList/<X>

This node acts as a placeholder for a V2X service which requires privacy for V2X communication over PC5.

- Occurrence: ZeroOrMore
- Format: node
- Access Types: Get, Replace

- Values: N/A

5.5.33 <X>/V2XoverPC5/PrivacyConfig/V2XServicePrivacyList/<X>/V2XServiceIdentifier

This node is the same as the node defined in subclause 5.5.22.

5.5.34 <X>/V2XoverPC5/PrivacyConfig/V2XServicePrivacyList/<X>/GeographicalAreaList

The GeographicalAreaList node contains the geographical area(s) in which the V2X service identified by the associated V2X service identifier requires privacy for V2X communication over PC5.

- Occurrence: ZeroOrOne
- Format: node
- Access Types: Get, Replace
- Values: N/A

5.5.35 <X>/V2XoverPC5/PrivacyConfig/V2XServicePrivacyList/<X>/GeographicalAreaList/<X>

This node acts as a placeholder for a geographical area in which the V2X service identified by the associated V2X service identifier requires privacy for V2X communication over PC5.

- Occurrence: ZeroOrMore
- Format: node
- Access Types: Get, Replace
- Values: N/A

5.5.36 <X>/V2XoverPC5/PrivacyConfig/V2XServicePrivacyList/<X>/GeographicalAreaList/<X>/GeographicalArea

The GeographicalArea node contains a geographical area description.

- Occurrence: One
- Format: node
- Access Types: Get, Replace
- Values: N/A

The UE is located in geographical area indicated by this node, if the UE is located in geographical area indicated by the Polygon child node.

5.5.37 <X>/V2XoverPC5/PrivacyConfig/V2XServicePrivacyList/<X>/GeographicalAreaList/<X>/GeographicalArea/Polygon

This node and its descendants are the same as the node defined in subclause 5.5.13.

5.5.38 <X>/V2XoverPC5/V2XServiceIDtoV2XFrequencyMappingRule

The V2XServiceIDtoV2XFrequencyMappingRule contains the mapping rules between the V2X service identifier and V2X frequency for V2X communication over the PC5.

- Occurrence: ZeroOrOne
- Format: node
- Access Types: Get, Replace
- Values: N/A

5.5.39 <X>/V2XoverPC5/V2XServiceIDtoV2XFrequencyMappingRule/<X>

This interior node acts as a placeholder for one or more mapping rules for V2X communication over the PC5.

- Occurrence: OneOrMore
- Format: node
- Access Types: Get, Replace
- Values: N/A

5.5.40 <X>/V2XoverPC5/V2XServiceIDtoV2XFrequencyMappingRule/<X>/V2XServiceIdentifier

This node is the same as the node defined in subclause 5.5.22.

5.5.41 <X>/V2XoverPC5/V2XServiceIDtoV2XFrequencyMappingRule/<X>/V2XFrequency

The V2XFrequency node contains the V2X frequency to which the V2X service identifier value associated to the same mapping rule is mapped.

- Occurrence: One
- Format: node
- Access Types: Get, Replace
- Values: N/A

5.5.42 <X>/V2XoverPC5/V2XServiceIDtoV2XFrequencyMappingRule/<X>/V2XFrequency/<X>

This interior node acts as a placeholder for one or more V2X frequencies used for V2X communication over the PC5.

- Occurrence: OneOrMore
- Format: node
- Access Types: Get, Replace
- Values: N/A

5.5.43 <X>/V2XoverPC5/V2XServiceIDtoV2XFrequencyMappingRule/<X>/V2XFrequency/<X>/V2XFrequency

The V2XFrequency leaf indicates the V2X frequency used for V2X communication over PC5.

- Occurrence: One
- Format: int
- Access Types: Get, Replace

- Values: <V2XFrequency>

The V2XFrequency is defined as *ARFCN-ValueEUTRA* in clause 6.3.4 of 3GPP TS 36.331 [8].

5.5.44 <X>/V2XoverPC5/V2XServiceIDtoV2XFrequencyMappingRule/<X>/GeographicalArea

The GeographicalArea node contains a geographical area description.

- Occurrence: One
- Format: node
- Access Types: Get, Replace
- Values: N/A

The UE is located in geographical area indicated by this node, if the UE is located in geographical area indicated by the Polygon child node.

5.5.45 <X>/V2XoverPC5/V2XServiceIDtoV2XFrequencyMappingRule/<X>/GeographicalArea/Polygon

This node and its descendants are the same as the node defined in subclause 5.5.13.

5.5.46 <X>/V2XoverPC5/V2XServiceIDtoTxProfileMappingRule

The V2XServiceIDtoTxProfileMappingRule contains the mapping rules between the V2X service identifier and Tx Profile for V2X communication over the PC5.

- Occurrence: ZeroOrOne
- Format: node
- Access Types: Get, Replace
- Values: N/A

5.5.47 <X>/V2XoverPC5/V2XServiceIDtoTxProfileMappingRule/<X>

This interior node acts as a placeholder for one or more mapping rules for V2X communication over the PC5.

- Occurrence: OneOrMore
- Format: node
- Access Types: Get, Replace
- Values: N/A

5.5.48 <X>/V2XoverPC5/V2XServiceIDtoTxProfileMappingRule/<X>/V2XServiceIdentifier

This node is the same as the node defined in subclause 5.5.22.

5.5.49 <X>/V2XoverPC5/V2XServiceIDtoTxProfileMappingRule/<X>/TxProfile

The TxProfile leaf indicates the Tx profile used for V2X communication over PC5.

- Occurrence: One
- Format: int
- Access Types: Get, Replace
- Values: <TxProfile>

The TxProfile is defined as *v2x-TxProfileList* in subclause 9.3.2 of 3GPP TS 36.331 [8].

5.5.50 <X>/V2XoverPC5/PPPRAuthorizationList

The PPPRAuthorizationList node contains configuration parameters for a list of the V2X services authorized for ProSe Per-Packet Reliability (PPPR).

- Occurrence: ZeroOrOne
- Format: node
- Access Types: Get, Replace
- Values: N/A

5.5.51 <X>/V2XoverPC5/PPPRAuthorizationList/<X>

This node acts as a placeholder for one entry of the list of the V2X services authorized for ProSe Per-Packet Reliability (PPPR).

- Occurrence: OneOrMore
- Format: node
- Access Types: Get, Replace
- Values: N/A

5.5.52 <X>/V2XoverPC5/PPPRAuthorizationList/<X>/V2XServiceIdentifier

This node is the same as the node defined in subclause 5.5.22.

5.5.53 <X>/V2XoverPC5/PPPRAuthorizationList/<X>/PPPRValue

The PPPRValue leaf indicates the PPPR value.

- Occurrence: One
- Format: int
- Access Types: Get, Replace
- Values: 1 to 8, where the higher value represents the lower reliability requirement for that message.

5.5A Configuration parameters for V2X communication over NR-PC5

5.5A.1 <X>/V2XoverPC5/V2XoverNRPC5

The V2XoverNRPC5 node contains the configuration parameters for V2X communication over NR-PC5.

- Occurrence: ZeroOrOne

- Format: node
- Access Types: Get, Replace
- Values: N/A

5.5A.2 <X>/V2XoverPC5/V2XoverNRPC5/ V2XServiceIDtoV2XNRFrequencyMappingRule

The V2XServiceIDtoV2XNRFrequencyMappingRule contains the mapping rules between the V2X service identifier and V2X NR frequency for V2X communication over the NR-PC5.

- Occurrence: ZeroOrOne
- Format: node
- Access Types: Get, Replace
- Values: N/A

5.5A.3 <X>/V2XoverPC5/V2XoverNRPC5/ V2XServiceIDtoV2XNRFrequencyMappingRule/<X>

This interior node acts as a placeholder for one or more mapping rules for V2X communication over the NR-PC5.

- Occurrence: OneOrMore
- Format: node
- Access Types: Get, Replace
- Values: N/A

5.5A.4 <X>/V2XoverPC5/V2XoverNRPC5/ V2XServiceIDtoV2XNRFrequencyMappingRule/<X>/ V2XServiceIdentifier

This node is the same as the node defined in subclause 5.5.22.

5.5A.5 <X>/V2XoverPC5/V2XoverNRPC5/ V2XServiceIDtoV2XNRFrequencyMappingRule/<X>/ V2XNRFrequency

The V2XNRFrequency node contains the V2X NR frequency to which the V2X service identifier value associated to the same mapping rule is mapped.

- Occurrence: One
- Format: node
- Access Types: Get, Replace
- Values: N/A

5.5A.6 <X>/V2XoverPC5/V2XoverNRPC5/ V2XServiceIDtoV2XNRFrequencyMappingRule/<X>/ V2XNRFrequency/<X>

This interior node acts as a placeholder for one or more V2X NR frequencies used for V2X communication over the NR-PC5.

- Occurrence: OneOrMore
- Format: node
- Access Types: Get, Replace
- Values: N/A

5.5A.7 <X>/V2XoverPC5/V2XoverNRPC5/ V2XServiceIDtoV2XNRFrequencyMappingRule/<X>/ V2XNRFrequency/<X>/V2XNRFrequency

The V2XNRFrequency leaf indicates the V2X NR frequency used for V2X communication over the NR-PC5.

- Occurrence: One
- Format: int
- Access Types: Get, Replace
- Values: <V2XNRFrequency>

The V2XNRFrequency is defined as *ARFCN-ValueNR* in clause 6.3.2 of 3GPP TS 38.331 [15].

5.5A.8 <X>/V2XoverPC5/V2XoverNRPC5/ V2XServiceIDtoV2XNRFrequencyMappingRule/<X>/ GeographicalArea

The GeographicalArea node contains a geographical area description.

- Occurrence: One
- Format: node
- Access Types: Get, Replace
- Values: N/A

The UE is located in geographical area indicated by this node, if the UE is located in geographical area indicated by the Polygon child node.

5.5A.9 <X>/V2XoverPC5/V2XoverNRPC5/ V2XServiceIDtoV2XNRFrequencyMappingRule/<X>/ GeographicalArea/Polygon

This node and its descendants are the same as the node defined in subclause 5.5.13.

5.5A.10 <X>/V2XoverPC5/V2XoverNRPC5/ V2XServiceIDtoBroadcastDestinationLayer2IDMappingRule

The V2XServiceIDtoBroadcastDestinationLayer2IDMappingRule node contains the mapping rules between the V2X service identifier and the destination layer-2 ID for broadcast for V2X communication over the NR-PC5.

- Occurrence: One
- Format: node
- Access Types: Get, Replace
- Values: N/A

5.5A.11 <X>/V2XoverPC5/V2XoverNRPC5/ V2XServiceIDtoBroadcastDestinationLayer2IDMappingRule/<X>

This interior node acts as a placeholder for one or more mapping rules for V2X communication over the NR-PC5.

- Occurrence: OneOrMore
- Format: node
- Access Types: Get, Replace
- Values: N/A

5.5A.12 <X>/V2XoverPC5/V2XoverNRPC5/ V2XServiceIDtoBroadcastDestinationLayer2IDMappingRule/<X>/ V2XServiceIdentifier

This node is the same as the node defined in subclause 5.5.22.

5.5A.13 <X>/V2XoverPC5/V2XoverNRPC5/ V2XServiceIDtoBroadcastDestinationLayer2IDMappingRule/<X>/ BroadcastDestinationlayer2ID

The BroadcastDestinationlayer2ID leaf indicates the destination layer-2 ID for broadcast used for V2X broadcast mode communication over the NR-PC5.

- Occurrence: One
- Format: bin
- Access Types: Get, Replace
- Values: <Destination Layer-2 ID>

The Destination Layer-2 ID is defined in 3GPP TS 38.300 [16].

5.5A.14 <X>/V2XoverPC5/V2XoverNRPC5/ DefaultBroadcastDestinationLayer2ID

The DefaultBroadcastDestinationLayer2ID leaf indicates the default destination layer-2 ID for broadcast used for V2X broadcast mode communication over the NR-PC5.

- Occurrence: ZeroOrOne
- Format: bin
- Access Types: Get, Replace
- Values: <Destination Layer-2 ID>

The Destination Layer-2 ID is defined in 3GPP TS 38.300 [16].

5.5A.15 <X>/V2XoverPC5/V2XoverNRPC5/ V2XServiceIDtoGroupcastDestinationLayer2IDMappingRule

The V2XServiceIDtoGroupcastDestinationLayer2IDMappingRule node contains the mapping rules between the V2X service identifier and the destination layer-2 ID for groupcast for V2X communication over the NR-PC5.

- Occurrence: One
- Format: node
- Access Types: Get, Replace
- Values: N/A

5.5A.16 <X>/V2XoverPC5/V2XoverNRPC5/ V2XServiceIDtoGroupcastDestinationLayer2IDMappingRule/<X>

This interior node acts as a placeholder for one or more mapping rules for V2X communication over the NR-PC5.

- Occurrence: OneOrMore
- Format: node
- Access Types: Get, Replace
- Values: N/A

5.5A.17 <X>/V2XoverPC5/V2XoverNRPC5/ V2XServiceIDtoGroupcastDestinationLayer2IDMappingRule/<X>/ V2XServiceIdentifier

This node is the same as the node defined in subclause 5.5.22.

5.5A.18 <X>/V2XoverPC5/V2XoverNRPC5/ V2XServiceIDtoGroupcastDestinationLayer2IDMappingRule/<X>/ GroupcastDestinationlayer2ID

The GroupcastDestinationlayer2ID leaf indicates the destination layer-2 ID for groupcast used for V2X groupcast mode communication over the NR-PC5.

- Occurrence: One
- Format: bin
- Access Types: Get, Replace
- Values: <Destination Layer-2 ID>

The Destination Layer-2 ID is defined in 3GPP TS 38.300 [16].

5.5A.19 <X>/V2XoverPC5/V2XoverNRPC5/ V2XServiceIDtoUnicastInitialSignallingDestinationLayer2IDMapping Rule

The V2XServiceIDtoUnicastInitialSignallingDestinationLayer2IDMappingRule node contains the mapping rules between the V2X service identifier and the destination layer-2 ID for unicast initial signaling for V2X communication over the NR-PC5.

- Occurrence: One

- Format: node
- Access Types: Get, Replace
- Values: N/A

5.5A.20 <X>/V2XoverPC5/V2XoverNRPC5/ V2XServiceIDtoUnicastInitialSignallingDestinationLayer2IDMapping Rule/<X>

This interior node acts as a placeholder for one or more mapping rules for V2X communication over the NR-PC5.

- Occurrence: OneOrMore
- Format: node
- Access Types: Get, Replace
- Values: N/A

5.5A.21 <X>/V2XoverPC5/V2XoverNRPC5/ V2XServiceIDtoUnicastInitialSignallingDestinationLayer2IDMapping Rule/<X>/V2XServiceIdentifier

This node is the same as the node defined in subclause 5.5.22.

5.5A.22 <X>/V2XoverPC5/V2XoverNRPC5/ V2XServiceIDtoUnicastInitialSignallingDestinationLayer2IDMapping Rule/<X>/UnicastInitialSignallingDestinationlayer2ID

The UnicastInitialSignallingDestinationlayer2ID leaf indicates the default destination layer-2 ID for unicast initial signaling used for V2X unicast mode communication over the NR-PC5.

- Occurrence: One
- Format: bin
- Access Types: Get, Replace
- Values: <Destination Layer-2 ID>

The Destination Layer-2 ID is defined in 3GPP TS 38.300 [16].

5.5A.23 <X>/V2XoverPC5/V2XoverNRPC5/ V2XServiceIDtoPC5QoSParametersMappingRule

The V2XServiceIDtoPC5QoSParametersMappingRule node contains the mapping rules between the V2X service identifier and PC5 QoS parameters for V2X communication over the NR-PC5.

- Occurrence: One
- Format: node
- Access Types: Get, Replace
- Values: N/A

5.5A.24 <X>/V2XoverPC5/V2XoverNRPC5/ V2XServiceIDtoPC5QoSParametersMappingRule/<X>

This interior node acts as a placeholder for one or more mapping rules for V2X communication over the NR-PC5.

- Occurrence: OneOrMore
- Format: node
- Access Types: Get, Replace
- Values: N/A

5.5A.25 <X>/V2XoverPC5/V2XoverNRPC5/ V2XServiceIDtoPC5QoSParametersMappingRule/<X>/ V2XServiceIdentifier

This node is the same as the node defined in subclause 5.5.22.

5.5A.26 <X>/V2XoverPC5/V2XoverNRPC5/ V2XServiceIDtoPC5QoSParametersMappingRule/<X>/PQI

The PQI leaf contains PC5 5QI value used for V2X communication over the NR-PC5.

- Occurrence: One
- Format: int
- Access Types: Get, Replace
- Values: 1 - 254

PQI values are listed in clause 5.4.4 of 3GPP TS 23.287 [17].

5.5A.27 <X>/V2XoverPC5/V2XoverNRPC5/ V2XServiceIDtoPC5QoSParametersMappingRule/<X>/ GuaranteedFlowBitRate

The GuaranteedFlowBitRate leaf contains guaranteed flow bit rate value for V2X communication over the NR-PC5.

- Occurrence: ZeroOrOne
- Format: bin
- Access Types: Get, Replace
- Values: <guaranteed flow bit rate>

Guaranteed flow bit rate values are defined in Table 5.3.1.46 of 3GPP TS 24.588 [18].

5.5A.28 <X>/V2XoverPC5/V2XoverNRPC5/ V2XServiceIDtoPC5QoSParametersMappingRule/<X>/ MaximumFlowBitRate

The MaximumFlowBitRate leaf contains maximum flow bit rate value for V2X communication over the NR-PC5.

- Occurrence: ZeroOrOne
- Format: bin

- Access Types: Get, Replace
- Values: <maximum flow bit rate>

Maximum flow bit rate values are defined in Table 5.3.1.46 of 3GPP TS 24.588 [18].

5.5A.29 <X>/V2XoverPC5/V2XoverNRPC5/ V2XServiceIDtoPC5QoSParametersMappingRule/<X>/ PerLinkAggregateMaximumBitRate

The PerLinkAggregateMaximumBitRate leaf contains per-link aggregate maximum bit rate value for V2X unicast mode communication over the NR-PC5.

- Occurrence: ZeroOrOne
- Format: bin
- Access Types: Get, Replace
- Values: <per-link aggregate maximum bit rate>

Per-link aggregate maximum bit rate values are defined in Table 5.3.1.46 of 3GPP TS 24.588 [18].

5.5A.30 <X>/V2XoverPC5/V2XoverNRPC5/ V2XServiceIDtoPC5QoSParametersMappingRule/<X>/Range

The Range leaf contains range value for V2X groupcast mode communication over the NR-PC5.

- Occurrence: ZeroOrOne
- Format: int
- Access Types: Get, Replace
- Values: 1-65535, a 16 bits unsigned integer value indicating range in meters.

5.5A.31 <X>/V2XoverPC5/V2XoverNRPC5/ASConfiguration

The ASConfiguration node contains various AS configurations for V2X communication over the NR-PC5.

- Occurrence: One
- Format: node
- Access Types: Get, Replace
- Values: N/A

5.5A.32 <X>/V2XoverPC5/V2XoverNRPC5/ASConfiguration/ SLRBMappingRule

The SLRBMappingRule node contains a list of SLRB mapping rules between the PC5 QoS profile and SLRB for V2X communication over the NR-PC5.

- Occurrence: One
- Format: node
- Access Types: Get, Replace
- Values: N/A

5.5A.33 <X>/V2XoverPC5/V2XoverNRPC5/ASConfiguration/ SLRBMappingRule/<X>

This interior node acts as a placeholder for one or more mapping rules for V2X communication over the NR-PC5.

- Occurrence: OneOrMore
- Format: node
- Access Types: Get, Replace
- Values: N/A

5.5A.34 <X>/V2XoverPC5/V2XoverNRPC5/ASConfiguration/ SLRBMappingRule/<X>/PC5QoSProfile

The PC5QoSProfile node contains PC5 QoS profile for V2X communication over the NR-PC5.

- Occurrence: One
- Format: node
- Access Types: Get, Replace
- Values: N/A

5.5A.35 <X>/V2XoverPC5/V2XoverNRPC5/ASConfiguration/ SLRBMappingRule/<X>/PC5QoSProfile/PQI

This node is the same as the node defined in subclause 5.5A.29.

5.5A.36 <X>/V2XoverPC5/V2XoverNRPC5/ASConfiguration/ SLRBMappingRule/<X>/PC5QoSProfile/GuaranteedFlowBitRate

This node is the same as the node defined in subclause 5.5A.30.

5.5A.37 <X>/V2XoverPC5/V2XoverNRPC5/ASConfiguration/ SLRBMappingRule/<X>/PC5QoSProfile/MaximumFlowBitRate

This node is the same as the node defined in subclause 5.5A.31.

5.5A.38 <X>/V2XoverPC5/V2XoverNRPC5/ASConfiguration/ SLRBMappingRule/<X>/PC5QoSProfile/ PerLinkAggregateMaximumBitRate

This node is the same as the node defined in subclause 5.5A.32.

5.5A.39 <X>/V2XoverPC5/V2XoverNRPC5/ASConfiguration/ SLRBMappingRule/<X>/PC5QoSProfile/Range

This node is the same as the node defined in subclause 5.5A.33.

5.5A.40 <X>/V2XoverPC5/V2XoverNRPC5/ASConfiguration/ SLRBMappingRule/<X>/PC5QoSProfile/PriorityLevel

The PriorityLevel leaf contains a ProSe per-packet priority value for V2X communication over the NR-PC5.

- Occurrence: ZeroOrOne
- Format: int
- Access Types: Get, Replace
- Values: 1-8

5.5A.41 <X>/V2XoverPC5/V2XoverNRPC5/ASConfiguration/ SLRBMappingRule/<X>/PC5QoSProfile/AveragingWindow

The AveragingWindow leaf contains the averaging window for both sending and receiving for V2X communication over the NR-PC5.

- Occurrence: ZeroOrOne
- Format: int
- Access Types: Get, Replace
- Values: 1-65535, a 16 bits unsigned integer value indicating averaging window in milliseconds.

5.5A.42 <X>/V2XoverPC5/V2XoverNRPC5/ASConfiguration/ SLRBMappingRule/<X>/PC5QoSProfile/MaximumDataBurstVolume

The MaximumDataBurstVolume leaf contains the maximum data burst volume value for both sending and receiving for V2X communication over the NR-PC5.

- Occurrence: ZeroOrOne
- Format: int
- Access Types: Get, Replace
- Values: 1-65535, a 16 bits unsigned integer value indicating maximum data burst volume in octets.

5.5A.43 <X>/V2XoverPC5/V2XoverNRPC5/ASConfiguration/ SLRBMappingRule/<X>/SLRB

The SLRB leaf contains an SLRB (sidelink radio bearer) value for V2X communication over the NR-PC5.

- Occurrence: One
- Format: bin
- Access Types: Get, Replace
- Values: <SLRB>

The SLRB is defined as *SL-PreconfigurationNR* in clause 9.3 of 3GPP TS 38.331 [15].

5.5A.44 <X>/V2XoverPC5/V2XoverNRPC5/ V2XServiceIDtoDefaultModeOfCommunicationMappingRule

The V2XServiceIDtoDefaultModeOfCommunicationMappingRule node contains the mapping rules between the V2X service identifier and the default mode of communication for V2X communication over the NR-PC5.

- Occurrence: One
- Format: node
- Access Types: Get, Replace

- Values: N/A

5.5A.45 <X>/V2XoverPC5/V2XoverNRPC5/ V2XServiceIDtoDefaultModeOfCommunicationMappingRule/<X>

This interior node acts as a placeholder for one or more mapping rules for V2X communication over the NR-PC5.

- Occurrence: OneOrMore
- Format: node
- Access Types: Get, Replace
- Values: N/A

5.5A.46 <X>/V2XoverPC5/V2XoverNRPC5/ V2XServiceIDtoDefaultModeOfCommunicationMappingRule/<X>/ V2XServiceIdentifier

This node is the same as the node defined in subclause 5.5.22.

5.5A.47 <X>/V2XoverPC5/V2XoverNRPC5/ V2XServiceIDtoDefaultModeOfCommunicationMappingRule/<X>/ DefaultModeOfCommunication

The DefaultModeOfCommunication leaf indicates the default mode of communication for V2X communication over the NR-PC5.

- Occurrence: One
- Format: bin
- Access Types: Get, Replace
- Values: <Default mode of communication>

Default mode of communication values are defined in Table 5.3.1.y of 3GPP TS 24.588 [18].

5.5A.48 <X>/V2XoverPC5/V2XoverNRPC5/NRPC5UnicastSecurityPolicies

The NRPC5UnicastSecurityPolicies node contains the security policies for V2X unicast mode communication over the NR-PC5.

- Occurrence: One
- Format: node
- Access Types: Get, Replace
- Values: N/A

5.5A.49 <X>/V2XoverPC5/V2XoverNRPC5/NRPC5UnicastSecurityPolicies/ <X>

This interior node acts as a placeholder for one or more mapping rules for V2X communication over the NR-PC5.

- Occurrence: OneOrMore
- Format: node

- Access Types: Get, Replace
- Values: N/A

5.5A.50 <X>/V2XoverPC5/V2XoverNRPC5/NRPC5UnicastSecurityPolicies/ <X>/V2XServiceIdentifier

This node is the same as the node defined in subclause 5.5.22.

5.5A.51 <X>/V2XoverPC5/V2XoverNRPC5/NRPC5UnicastSecurityPolicies/ <X>/SecurityPolicies

The SecurityPolicies node contains security policies for V2X communication over the NR-PC5.

- Occurrence: One
- Format: node
- Access Types: Get, Replace
- Values: N/A

5.5A.52 <X>/V2XoverPC5/V2XoverNRPC5/NRPC5UnicastSecurityPolicies/ <X>/SecurityPolicies/SignallingIntegrityProtectionPolicy

The SignallingIntegrityProtectionPolicy leaf indicates the signalling integrity protection policy for V2X communication over the NR-PC5.

- Occurrence: One
- Format: bin
- Access Types: Get, Replace
- Values: <signalling integrity protection policy>

Signalling integrity protection policy values are defined in Table 5.3.1.cc of 3GPP TS 24.588 [18].

5.5A.53 <X>/V2XoverPC5/V2XoverNRPC5/NRPC5UnicastSecurityPolicies/ <X>/SecurityPolicies/SignallingCipheringPolicy

The SignallingCipheringPolicy leaf indicates the signalling ciphering policy for V2X communication over the NR-PC5.

- Occurrence: One
- Format: bin
- Access Types: Get, Replace
- Values: <signalling ciphering policy>

Signalling ciphering policy values are defined in Table 5.3.1.cc of 3GPP TS 24.588 [18].

5.5A.54 <X>/V2XoverPC5/V2XoverNRPC5/NRPC5UnicastSecurityPolicies/ <X>/SecurityPolicies/UserPlaneIntegrityProtectionPolicy

The UserPlaneIntegrityProtectionPolicy leaf indicates the user plane integrity protection policy for V2X communication over the NR-PC5.

- Occurrence: One

- Format: bin
- Access Types: Get, Replace
- Values: <user plane integrity protection policy>

User plane integrity protection policy values are defined in Table 5.3.1.cc of 3GPP TS 24.588 [18].

5.5A.55 <X>/V2XoverPC5/V2XoverNRPC5/NRPC5UnicastSecurityPolicies/ <X>/SecurityPolicies/SignallingCipheringPolicy

The UserPlaneCipheringPolicy leaf indicates the user plane ciphering policy for V2X communication over the NR-PC5.

- Occurrence: One
- Format: bin
- Access Types: Get, Replace
- Values: <user plane ciphering policy>

User plane ciphering policy values are defined in Table 5.3.1.cc of 3GPP TS 24.588 [18].

5.5A.56 <X>/V2XoverPC5/V2XoverNRPC5/NRPC5UnicastSecurityPolicies/ <X>/GeographicalArea

The GeographicalArea node contains a geographical area description.

- Occurrence: One
- Format: node
- Access Types: Get, Replace
- Values: N/A

The UE is located in geographical area indicated by this node, if the UE is located in geographical area indicated by the Polygon child node.

5.5A.57 <X>/V2XoverPC5/V2XoverNRPC5/NRPC5UnicastSecurityPolicies/ <X>/GeographicalArea/Polygon

This node and its descendants are the same as the node defined in subclause 5.5.13.

5.6 Configuration parameters for V2X communication over LTE-Uu

5.6.1 <X>/V2XoverLTEUu

The V2XoverLTEUu node contains the configuration parameters for V2X communication over LTE-Uu.

- Occurrence: One
- Format: node
- Access Types: Get, Replace
- Values: N/A

5.6.2 <X>/V2XoverLTEUu/Expiration

The Expiration leaf indicates the expiration time of validity of the configuration parameters for V2X communication over LTE-Uu.

- Occurrence: One
- Format: int
- Access Types: Get, Replace
- Values: a 40 bits unsigned integer value indicating a UTC time, in seconds since midnight UTC of January 1, 1970 (not counting leap seconds).

5.6.3 <X>/V2XoverLTEUu/ToConRefs

The ToConRefs node is used to allow application to refer to a collection of connectivity definitions. Several connectivity parameters can be listed for a given application under this node.

This node contains configuration parameters for establishment of the PDN connection for reaching the V2X application server.

- Occurrence: ZeroOrOne
- Format: node
- Access Types: Get, Replace
- Values: N/A

5.6.4 <X>/V2XoverLTEUu/ToConRefs/<X>

This run-time node acts as a placeholder for each reference to connectivity parameters.

- Occurrence: OneOrMore
- Format: node
- Access Types: Get, Replace
- Values: N/A

5.6.5 <X>/V2XoverLTEUu/ToConRefs/<X>/ConRef

The ConRef leaf indicates a specific linkage to connectivity parameters.

- Occurrence: One
- Format: chr
- Access Types: Get, Replace
- Values: <A network access point object as defined in OMA-DDS-DM_ConnMO [14]>

5.6.6 <X>/V2XoverLTEUu/AuthorizedPLMNs

The AuthorizedPLMNs node contains a list of PLMNs in which the UE is authorized to use V2X communication over LTE-Uu.

- Occurrence: One
- Format: node
- Access Types: Get, Replace

- Values: N/A

5.6.7 <X>/V2XoverLTEUu/AuthorizedPLMNs/<X>

This node acts as a placeholder for a PLMN in which the UE is authorized to use V2X communication over LTE-Uu.

- Occurrence: ZeroOrMore
- Format: node
- Access Types: Get, Replace
- Values: N/A

5.6.8 <X>/V2XoverLTEUu/AuthorizedPLMNs/<X>/PLMN

The PLMN leaf indicates a PLMN code of a PLMN in which the UE is authorized to use V2X communication over LTE-Uu.

- Occurrence: One
- Format: chr
- Access Types: Get, Replace
- Values: <PLMN code>

The format of the PLMN code is defined by 3GPP TS 23.003 [7].

5.6.9 <X>/V2XoverLTEUu/AuthorizedPLMNs/<X>/V2XASMBMSConfig

The V2XASMBMSConfig node contains an MBMS configuration for receiving V2X application server information using MBMS in the PLMN in which this authorization policy applies.

- Occurrence: ZeroOrOne
- Format: node
- Access Types: Get, Replace
- Values: N/A

5.6.10 <X>/V2XoverLTEUu/AuthorizedPLMNs/<X>/V2XASMBMSConfig/ TMGI

The TMGI leaf indicates a TMGI for receiving V2X application server information using MBMS in the PLMN in which this authorization policy applies.

- Occurrence: One
- Format: chr
- Access Types: Get, Replace
- Values: <TMGI>

The format of the TMGI is defined by 3GPP TS 23.003 [7].

5.6.11 <X>/V2XoverLTEUu/AuthorizedPLMNs/<X>/V2XASMBMSConfig/SAIList

The SAIList node contains a list of Service Area Identifiers (SAIs) for receiving V2X application server information using MBMS in the PLMN in which this authorization policy applies.

- Occurrence: One
- Format: node
- Access Types: Get, Replace
- Values: N/A

5.6.12 <X>/V2XoverLTEUu/AuthorizedPLMNs/<X>/V2XASMBMSConfig/SAIList/<X>

This interior node acts as a placeholder for one or more SAI(s) for receiving V2X application server information using MBMS in the PLMN in which this authorization policy applies.

- Occurrence: OneOrMore
- Format: node
- Access Types: Get, Replace
- Values: N/A

5.6.13 <X>/V2XoverLTEUu/AuthorizedPLMNs/<X>/V2XASMBMSConfig/SAIList/<X>/SAI

The SAI leaf indicates an SAI for receiving V2X application server information using MBMS in the PLMN in which this authorization policy applies.

- Occurrence: One
- Format: chr
- Access Types: Get, Replace
- Values: <SAI>

The format of the SAI is defined by 3GPP TS 23.003 [7].

5.6.14 <X>/V2XoverLTEUu/AuthorizedPLMNs/<X>/V2XASMBMSConfig/Frequency

The Frequency leaf indicates a frequency for receiving V2X application server information using MBMS in the PLMN in which this authorization policy applies.

- Occurrence: ZeroOrOne
- Format: chr
- Access Types: Get, Replace
- Values: <EARFCN>

The format of the EARFCN is defined by 3GPP TS 36.101 [11].

5.6.15 <X>/V2XoverLTEUu/AuthorizedPLMNs/<X>/V2XASMBMSConfig/SDPInV2XASMBMSConfig

The SDPInV2XASMBMSConfig leaf indicates an SDP for receiving V2X application server information using MBMS in the PLMN in which this authorization policy applies.

- Occurrence: One
- Format: chr
- Access Types: Get, Replace
- Values: <SDPInV2XASMBMSConfig>

The format of the SDPInV2XASMBMSConfig is defined by 3GPP TS 24.386 [4].

5.6.16 <X>/V2XoverLTEUu/AuthorizedPLMNs/<X>/V2XServiceIdentifierUnrelated

The V2XServiceIdentifierUnrelated node contains parameters related to V2X services not identified by a V2X service identifier.

- Occurrence: One
- Format: node
- Access Types: Get, Replace
- Values: N/A

The V2XMBMSConfigs child node describes one or more MBMS configurations for receiving a V2X message using V2X communication over LTE-Uu applicable when the V2X message is of a V2X service not identified by a V2X service identifier.

Absence of the V2XMBMSConfigs child node indicates that the UE cannot receive the V2X messages of V2X services not identified by a V2X service identifier using V2X communication over LTE-Uu using MBMS.

The V2XASAddresses child node contains the V2X application server addresses for transport of a V2X message using V2X communication over LTE-Uu applicable when the V2X message is of a V2X service not identified by a V2X service identifier.

Absence of the V2XASAddresses child node indicates that the UE cannot receive the V2X messages of V2X services not identified by a V2X service identifier using V2X communication over LTE-Uu using unicast and that the UE cannot send V2X messages of V2X services not identified by a V2X service identifier using V2X communication over LTE-Uu.

5.6.17 <X>/V2XoverLTEUu/AuthorizedPLMNs/<X>/V2XServiceIdentifierUnrelated/V2XMBMSConfigs

The V2XMBMSConfig node contains one or more MBMS configurations for receiving V2X messages using MBMS in the PLMN in which this authorization policy applies.

- Occurrence: ZeroOrOne
- Format: node
- Access Types: Get, Replace
- Values: N/A

5.6.18 <X>/V2XoverLTEUu/AuthorizedPLMNs/<X>/ V2XServiceIdentifierUnrelated/V2XMBMSConfigs/<X>

This node acts as a placeholder for one or more MBMS configurations for receiving V2X messages using MBMS in the PLMN in which this authorization policy applies.

- Occurrence: OneOrMore
- Format: node
- Access Types: Get, Replace
- Values: N/A

5.6.19 <X>/V2XoverLTEUu/AuthorizedPLMNs/<X>/ V2XServiceIdentifierUnrelated/V2XMBMSConfigs/<X>/V2XMBMSC onfig

The V2XMBMSConfig node contains an MBMS configuration for receiving V2X messages using MBMS in the PLMN in which this authorization policy applies.

- Occurrence: One
- Format: node
- Access Types: Get, Replace
- Values: N/A

5.6.20 <X>/V2XoverLTEUu/AuthorizedPLMNs/<X>/ V2XServiceIdentifierUnrelated/V2XMBMSConfigs/<X>/V2XMBMSC onfig/TMGI

The TMGI leaf indicates a TMGI for receiving V2X messages using MBMS in the PLMN in which this authorization policy applies.

- Occurrence: One
- Format: chr
- Access Types: Get, Replace
- Values: <TMGI>

The format of the TMGI is defined by 3GPP TS 23.003 [7].

5.6.21 <X>/V2XoverLTEUu/AuthorizedPLMNs/<X>/ V2XServiceIdentifierUnrelated/V2XMBMSConfigs/<X>/V2XMBMSC onfig/SAIList

The SAIList node contains a list of Service Area Identifiers (SAIs) for receiving V2X messages using MBMS in the PLMN in which this authorization policy applies.

- Occurrence: One
- Format: node
- Access Types: Get, Replace
- Values: N/A

5.6.22 <X>/V2XoverLTEUu/AuthorizedPLMNs/<X>/ V2XServiceIdentifierUnrelated/V2XMBMSConfigs/<X>/V2XMBMSC onfig/SAIList/<X>

This interior node acts as a placeholder for one or more SAI(s) for receiving V2X messages using MBMS in the PLMN in which this authorization policy applies.

- Occurrence: OneOrMore
- Format: node
- Access Types: Get, Replace
- Values: N/A

5.6.23 <X>/V2XoverLTEUu/AuthorizedPLMNs/<X>/ V2XServiceIdentifierUnrelated/V2XMBMSConfigs/<X>/V2XMBMSC onfig/SAIList/<X>/SAI

The SAI leaf indicates an SAI for receiving V2X messages using MBMS in the PLMN in which this authorization policy applies.

- Occurrence: One
- Format: chr
- Access Types: Get, Replace
- Values: <SAI>

The format of the SAI is defined by 3GPP TS 23.003 [7].

5.6.24 <X>/V2XoverLTEUu/AuthorizedPLMNs/<X>/ V2XServiceIdentifierUnrelated/V2XMBMSConfigs/<X>/V2XMBMSC onfig/Frequency

The Frequency leaf indicates a frequency for receiving V2X messages using MBMS in the PLMN in which this authorization policy applies.

- Occurrence: ZeroOrOne
- Format: chr
- Access Types: Get, Replace
- Values: <EARFCN>

The format of the EARFCN is defined by 3GPP TS 36.101 [11].

5.6.25 <X>/V2XoverLTEUu/AuthorizedPLMNs/<X>/ V2XServiceIdentifierUnrelated/V2XMBMSConfigs/<X>/V2XMBMSC onfig/ SDPInV2XMBMSConfig

The SDPInV2XMBMSConfig leaf indicates an SDP for receiving V2X messages using MBMS in the PLMN in which this authorization policy applies.

- Occurrence: One
- Format: chr

- Access Types: Get, Replace
- Values: <SDPInV2XMBMSConfig>

The format of the SDPInV2XMBMSConfig is defined by 3GPP TS 24.386 [4].

5.6.26 <X>/V2XoverLTEUu/AuthorizedPLMNs/<X>/ V2XServiceIdentifierUnrelated/V2XASAddresses

The V2XASAddresses node contains V2X server addresses for transport of V2X messages.

- Occurrence: ZeroOrOne
- Format: node
- Access Types: Get, Replace
- Values: N/A

5.6.27 <X>/V2XoverLTEUu/AuthorizedPLMNs/<X>/ V2XServiceIdentifierUnrelated/V2XASAddress/<X>

This node acts as a placeholder for a V2X server address applicable in a geographical area.

- Occurrence: OneOrMore
- Format: node
- Access Types: Get, Replace
- Values: N/A

If the GeographicalArea child node is included, the V2X server address indicated in the L3Address child node and UDPPort child node is applicable when the UE is located in geographical area indicated by the GeographicalArea child node.

If the GeographicalArea child node is not included, the V2X server address indicated in the L3Address child node and UDPPort child node is not restricted to a geographical area.

5.6.28 <X>/V2XoverLTEUu/AuthorizedPLMNs/<X>/ V2XServiceIdentifierUnrelated/V2XASAddress/<X>/L3Address

The L3Address leaf indicates a IP address or FQDN of the V2X application server.

- Occurrence: One
- Format: chr
- Access Types: Get, Replace
- Values: an FQDN or an IP address.

5.6.29 <X>/V2XoverLTEUu/AuthorizedPLMNs/<X>/ V2XServiceIdentifierUnrelated/V2XASAddress/<X>/UDPPort

The UDPPort leaf indicates a UDP port of the V2X application server.

- Occurrence: One
- Format: int
- Access Types: Get, Replace

- Values: integer between 0 and 65535

5.6.30 <X>/V2XoverLTEUu/AuthorizedPLMNs/<X>/ V2XServiceIdentifierUnrelated/V2XASAddress/<X>/ GeographicalArea

The GeographicalArea node contains a geographical area description.

- Occurrence: ZeroOrOne
- Format: node
- Access Types: Get, Replace
- Values: N/A

The UE is located in geographical area indicated by this node, if the UE is located in geographical area indicated by the Polygon child node.

5.6.31 <X>/V2XoverLTEUu/AuthorizedPLMNs/<X>/ V2XServiceIdentifierUnrelated/V2XASAddress/<X>/GeographicalAr ea/Polygon

This node and its descendants are the same as the node defined in subclause 5.5.13.

5.6.32 <X>/V2XoverLTEUu/AuthorizedPLMNs/<X>/ V2XServiceIdentifierRelated

The V2XServiceIdentifierRelated node contains parameters related to V2X services identified by a V2X service identifier.

The AuthorizedV2XServiceList child node indicates parameters related to V2X services identified by a particular V2X service identifier.

The DefaultV2XMBMSConfigs child node and the DefaultV2XASAddresses child node indicate parameters related to a V2X service identified by a V2X service identifier for which the AuthorizedV2XServiceList child node does not contain the parameters.

- Occurrence: One
- Format: node
- Access Types: Get, Replace
- Values: N/A

5.6.33 <X>/V2XoverLTEUu/AuthorizedPLMNs/<X>/ V2XServiceIdentifierRelated/AuthorizedV2XServiceList

The AuthorizedV2XServiceList node contains V2X services identified by a V2X service identifier, authorized for V2X communication over LTE-Uu.

- Occurrence: One
- Format: node
- Access Types: Get, Replace
- Values: N/A

5.6.34 <X>/V2XoverLTEUu/AuthorizedPLMNs/<X>/ V2XServiceIdentifierRelated/AuthorizedV2XServiceList/<X>

This node acts as a placeholder for a V2X service identified by a V2X service identifier, authorized for V2X communication over LTE-Uu.

- Occurrence: ZeroOrMore
- Format: node
- Access Types: Get, Replace
- Values: N/A

The V2XMBMSConfigs child node describes one or more MBMS configuration(s) for receiving a V2X message using V2X communication over LTE-Uu applicable when the V2X message is of a V2X service with the V2X service identifier indicated by the V2XServiceIdentifier child node.

Absence of the V2XMBMSConfigs child node indicates that the UE cannot receive the V2X messages of the V2X service with the V2X service identifier indicated by the V2XServiceIdentifier child node using V2X communication over LTE-Uu using MBMS.

The V2XASAddresses child node contains the V2X application server addresses for transport of a V2X message using V2X communication over LTE-Uu applicable when the V2X message is of a V2X service with the V2X service identifier indicated by the V2XServiceIdentifier child node.

Absence of the V2XASAddresses child node indicates that the UE cannot receive the V2X messages of the V2X service with the V2X service identifier indicated by the V2XServiceIdentifier child node using V2X communication over LTE-Uu using unicast and that the UE cannot send V2X messages of the V2X service with the V2X service identifier indicated by the V2XServiceIdentifier child node using V2X communication over LTE-Uu, except when using TCP.

The V2XASTCPAddresses child node contains the V2X application server addresses for transport of a V2X message using V2X communication over LTE-Uu using TCP applicable when the V2X message is of a V2X service with the V2X service identifier indicated by the V2XServiceIdentifier child node.

Absence of the V2XASTCPAddresses child node indicates that the UE cannot receive the V2X messages of the V2X service with the V2X service identifier indicated by the V2XServiceIdentifier child node using V2X communication over LTE-Uu using unicast and that the UE cannot send V2X messages of the V2X service with the V2X service identifier indicated by the V2XServiceIdentifier child node using V2X communication over LTE-Uu, using TCP.

5.6.35 <X>/V2XoverLTEUu/AuthorizedPLMNs/<X>/ V2XServiceIdentifierRelated/AuthorizedV2XServiceList/<X>/ V2XServiceIdentifier

This node is the same as the node defined in subclause 5.5.22.

5.6.36 <X>/V2XoverLTEUu/AuthorizedPLMNs/<X>/ V2XServiceIdentifierRelated/AuthorizedV2XServiceList/<X>/ V2XMBMSConfigs

The V2XMBMSConfig node contains one or more MBMS configurations for receiving V2X messages using MBMS in the PLMN in which this authorization policy applies.

- Occurrence: ZeroOrOne
- Format: node
- Access Types: Get, Replace
- Values: N/A

5.6.37 <X>/V2XoverLTEUu/AuthorizedPLMNs/<X>/
V2XServiceIdentifierRelated/AuthorizedV2XServiceList/<X>/
V2XMBMSConfigs/<X>

This node acts as a placeholder for one or more MBMS configurations for receiving V2X messages using MBMS in the PLMN in which this authorization policy applies.

- Occurrence: OneOrMore
- Format: node
- Access Types: Get, Replace
- Values: N/A

5.6.38 <X>/V2XoverLTEUu/AuthorizedPLMNs/<X>/
V2XServiceIdentifierRelated/AuthorizedV2XServiceList/<X>/V2XMB
MSConfigs/<X>/
V2XMBMSConfig

The V2XMBMSConfig node contains an MBMS configuration for receiving V2X messages using MBMS, for the associated V2X service identifier, in the PLMN in which this authorization policy applies.

- Occurrence: One
- Format: node
- Access Types: Get, Replace
- Values: N/A

5.6.39 <X>/V2XoverLTEUu/AuthorizedPLMNs/<X>/
V2XServiceIdentifierRelated/AuthorizedV2XServiceList/<X>/V2XMB
MSConfigs/<X>/
V2XMBMSConfig/TMGI

The TMGI leaf indicates a TMGI for receiving V2X messages using MBMS, for the associated V2X service identifier, in the PLMN in which this authorization policy applies.

- Occurrence: ZeroOrOne
- Format: chr
- Access Types: Get, Replace
- Values: <TMGI>

The format of the TMGI is defined by 3GPP TS 23.003 [7].

5.6.40 <X>/V2XoverLTEUu/AuthorizedPLMNs/<X>/
V2XServiceIdentifierRelated/AuthorizedV2XServiceList/<X>/V2XMB
MSConfigs/<X>/
V2XMBMSConfig/SAIList

The SAIList node contains a list of Service Area Identifiers (SAIs) for receiving V2X messages using MBMS, for the associated V2X service identifier, in the PLMN in which this authorization policy applies.

- Occurrence: One

- Format: node
- Access Types: Get, Replace
- Values: N/A

5.6.41 <X>/V2XoverLTEUu/AuthorizedPLMNs/<X>/ V2XServiceIdentifierRelated/AuthorizedV2XServiceList/<X>/V2XMB MSConfigs/<X>/ V2XMBMSConfig/SAIList/<X>

This interior node acts as a placeholder for one or more SAI(s) for receiving V2X messages using MBMS, for the associated V2X service identifier, in the PLMN in which this authorization policy applies.

- Occurrence: OneOrMore
- Format: node
- Access Types: Get, Replace
- Values: N/A

5.6.42 <X>/V2XoverLTEUu/AuthorizedPLMNs/<X>/ V2XServiceIdentifierRelated/AuthorizedV2XServiceList/<X>/V2XMB MSConfigs/<X>/ V2XMBMSConfig/SAIList/<X>/SAI

The SAI leaf indicates an SAI for receiving V2X messages using MBMS, for the associated V2X service identifier, in the PLMN in which this authorization policy applies.

- Occurrence: One
- Format: chr
- Access Types: Get, Replace
- Values: <SAI>

The format of the SAI is defined by 3GPP TS 23.003 [7].

5.6.43 <X>/V2XoverLTEUu/AuthorizedPLMNs/<X>/ V2XServiceIdentifierRelated/AuthorizedV2XServiceList/<X>/V2XMB MSConfigs/<X>/ V2XMBMSConfig/Frequency

The Frequency leaf indicates a frequency for receiving V2X messages using MBMS, for the associated V2X service identifier, in the PLMN in which this authorization policy applies.

- Occurrence: ZeroOrOne
- Format: chr
- Access Types: Get, Replace
- Values: <EARFCN>

The format of the EARFCN is defined by 3GPP TS 36.101 [11].

5.6.44 <X>/V2XoverLTEUu/AuthorizedPLMNs/<X>/
 V2XServiceIdentifierRelated/AuthorizedV2XServiceList/<X>/V2XMB
 MSConfigs/<X>/
 V2XMBMSConfig/SDPInV2XMBMSConfig

The SDPInV2XMBMSConfig leaf indicates an SDP for receiving V2X messages using MBMS, for the associated V2X service identifier, in the PLMN in which this authorization policy applies.

- Occurrence: One
- Format: chr
- Access Types: Get, Replace
- Values: <SDPInV2XMBMSConfig>

The format of the SDPInV2XMBMSConfig is defined by 3GPP TS 24.386 [4].

- NOTE: The V2X message family information is not included in the SDPInV2XMBMSConfig contained in this leaf since the SDPInV2XMBMSConfig is associated with a V2X service identifier.

5.6.45 <X>/V2XoverLTEUu/AuthorizedPLMNs/<X>/
 V2XServiceIdentifierRelated/AuthorizedV2XServiceList/<X>/
 V2XASAddresses

This node and its descendants are the same as the node defined in subclause 5.6.26.

5.6.45A <X>/V2XoverLTEUu/AuthorizedPLMNs/<X>/
 V2XServiceIdentifierRelated/AuthorizedV2XServiceList/<X>/
 V2XASTCPAddresses

The V2XASTCPAddresses node contains V2X server addresses for transport of V2X messages using TCP.

- Occurrence: ZeroOrOne
- Format: node
- Access Types: Get, Replace
- Values: N/A

5.6.45B <X>/V2XoverLTEUu/AuthorizedPLMNs/<X>/
 V2XServiceIdentifierRelated/AuthorizedV2XServiceList/<X>/
 V2XASTCPAddresses/<X>

This node acts as a placeholder for a V2X server address for communication using TCP applicable in a geographical area.

- Occurrence: OneOrMore
- Format: node
- Access Types: Get, Replace
- Values: N/A

If the GeographicalArea child node is included, the V2X server address indicated in the L3Address child node and the TCPPort child nodes are applicable when the UE is located in a geographical area indicated by the GeographicalArea child node.

If the GeographicalArea child node is not included, the V2X server address indicated in the L3Address child node and the TCPPort child nodes are not restricted to a geographical area.

5.6.45C <X>/V2XoverLTEUu/AuthorizedPLMNs/<X>/ V2XServiceIdentifierRelated/AuthorizedV2XServiceList/<X>/ V2XASTCPAddresses/<X>/L3Address

This node and its descendants are the same as the node defined in subclause 5.6.28.

5.6.45D <X>/V2XoverLTEUu/AuthorizedPLMNs/<X>/ V2XServiceIdentifierUnrelated/V2XASTCPAddress/<X>/TCPPort

The TCPPort leaf indicates a TCP port of the V2X application server for bidirectional transport.

- Occurrence: ZeroOrOne
- Format: int
- Access Types: Get, Replace
- Values: integer between 0 and 65535

5.6.45E <X>/V2XoverLTEUu/AuthorizedPLMNs/<X>/ V2XServiceIdentifierUnrelated/V2XASTCPAddress/<X>/ GeographicalArea

This node and its descendants are the same as the node defined in subclause 5.6.30.

5.6.46 <X>/V2XoverLTEUu/AuthorizedPLMNs/<X>/ V2XServiceIdentifierRelated/DefaultV2XMBMSConfigs

The V2XMBMSConfig node contains one or more default MBMS configurations for receiving V2X messages using MBMS in the PLMN in which this authorization policy applies.

- Occurrence: ZeroOrOne
- Format: node
- Access Types: Get, Replace
- Values: N/A

5.6.47 <X>/V2XoverLTEUu/AuthorizedPLMNs/<X>/ V2XServiceIdentifierRelated/DefaultV2XMBMSConfigs/<X>

This node acts as a placeholder for one or more default MBMS configurations for receiving V2X messages of V2X services with a V2X service identifier using MBMS in the PLMN in which this authorization policy applies.

- Occurrence: OneOrMore
- Format: node
- Access Types: Get, Replace
- Values: N/A

5.6.48 <X>/V2XoverLTEUu/AuthorizedPLMNs/<X>/ V2XServiceIdentifierRelated/DefaultV2XMBMSConfigs/<X>/ V2XMBMSConfig

The V2XMBMSConfig node contains a default MBMS configuration for receiving V2X messages of V2X services with a V2X service identifier using MBMS, in the PLMN in which this authorization policy applies.

- Occurrence: One
- Format: node
- Access Types: Get, Replace
- Values: N/A

5.6.49 <X>/V2XoverLTEUu/AuthorizedPLMNs/<X>/ V2XServiceIdentifierRelated/DefaultV2XMBMSConfigs/<X>/ V2XMBMSConfig/TMGI

The TMGI leaf indicates a TMGI for receiving V2X messages of V2X services with a V2X service identifier using MBMS, in the PLMN in which this authorization policy applies.

- Occurrence: ZeroOrOne
- Format: chr
- Access Types: Get, Replace
- Values: <TMGI>

The format of the TMGI is defined by 3GPP TS 23.003 [7].

5.6.50 <X>/V2XoverLTEUu/AuthorizedPLMNs/<X>/ V2XServiceIdentifierRelated/DefaultV2XMBMSConfigs/<X>/ V2XMBMSConfig/SAIList

The SAIList node contains a list of Service Area Identifiers (SAIs) for receiving V2X messages of V2X services with a V2X service identifier using MBMS, in the PLMN in which this authorization policy applies.

- Occurrence: One
- Format: node
- Access Types: Get, Replace
- Values: N/A

5.6.51 <X>/V2XoverLTEUu/AuthorizedPLMNs/<X>/ V2XServiceIdentifierRelated/DefaultV2XMBMSConfigs/<X>/ V2XMBMSConfig/SAIList/<X>

This interior node acts as a placeholder for one or more SAI(s) for receiving V2X messages of V2X services with a V2X service identifier using MBMS, in the PLMN in which this authorization policy applies.

- Occurrence: OneOrMore
- Format: node
- Access Types: Get, Replace

- Values: N/A

5.6.52 <X>/V2XoverLTEUu/AuthorizedPLMNs/<X>/ V2XServiceIdentifierRelated/DefaultV2XMBMSConfigs/<X>/ V2XMBMSConfig/SAIList/<X>/SAI

The SAI leaf indicates an SAI for receiving V2X messages of V2X services with a V2X service identifier using MBMS, in the PLMN in which this authorization policy applies.

- Occurrence: One
- Format: chr
- Access Types: Get, Replace
- Values: <SAI>

The format of the SAI is defined by 3GPP TS 23.003 [7].

5.6.53 <X>/V2XoverLTEUu/AuthorizedPLMNs/<X>/ V2XServiceIdentifierRelated/DefaultV2XMBMSConfigs/<X>/ V2XMBMSConfig/Frequency

The Frequency leaf indicates a frequency for receiving V2X messages of V2X services with a V2X service identifier using MBMS, in the PLMN in which this authorization policy applies.

- Occurrence: ZeroOrOne
- Format: chr
- Access Types: Get, Replace
- Values: <EARFCN>

The format of the EARFCN is defined by 3GPP TS 36.101 [11].

5.6.54 <X>/V2XoverLTEUu/AuthorizedPLMNs/<X>/ V2XServiceIdentifierRelated/DefaultV2XMBMSConfigs/<X>/ V2XMBMSConfig/SDPInV2XMBMSConfig

The SDPInV2XMBMSConfig leaf indicates an SDP for receiving V2X messages of V2X services with a V2X service identifier using MBMS, in the PLMN in which this authorization policy applies.

- Occurrence: One
- Format: chr
- Access Types: Get, Replace
- Values: <SDPInV2XMBMSConfig>

The format of the SDPInV2XMBMSConfig is defined by 3GPP TS 24.386 [4].

5.6.55 <X>/V2XoverLTEUu/AuthorizedPLMNs/<X>/ V2XServiceIdentifierRelated/ DefaultV2XASAddresses

The V2XASAddresses node contains default V2X server addresses for transport of V2X messages.

- Occurrence: ZeroOrOne

- Format: node
- Access Types: Get, Replace
- Values: N/A

5.6.56 <X>/V2XoverLTEUu/AuthorizedPLMNs/<X>/ V2XServiceIdentifierRelated/ DefaultV2XASAddresses/<X>

This node acts as a placeholder for default V2X server addresses for transport of V2X messages.

- Occurrence: OneOrMore
- Format: node
- Access Types: Get, Replace
- Values: N/A

5.6.57 <X>/V2XoverLTEUu/AuthorizedPLMNs/<X>/ V2XServiceIdentifierRelated/ DefaultV2XASAddresses/<X>/TypeOfData

The TypeOfData node indicates type of data of V2X message.

- Occurrence: One
 - Format: int
 - Access Types: Get, Replace
 - Values: 0, 1
- 0 IP type of data.
- 1 non-IP type of data.

5.6.58 <X>/V2XoverLTEUu/AuthorizedPLMNs/<X>/ V2XServiceIdentifierRelated/ DefaultV2XASAddresses/<X>/V2XMessageFamily

The V2XMessageFamily node indicates V2X message family of V2X message of non-IP type of data.

- Occurrence: ZeroOrOne
- Format: int
- Access Types: Get, Replace
- Values: <a V2X message family as specified in 3GPP TS 24.386 [4] subclause 7.1>

5.6.59 <X>/V2XoverLTEUu/AuthorizedPLMNs/<X>/ V2XServiceIdentifierRelated/DefaultV2XASAddresses/<X>/ V2XASAddresses

This node and its descendants are the same as the node defined in subclause 5.6.26.

5.6.60 <X>/V2XoverLTEUu/AuthorizedPLMNs/<X>/ V2XServiceIdentifierRelated/IPUnicastRoutingV2XServiceList

The IPUnicastRoutingV2XServiceList node contains V2X services identified by a V2X service identifier, authorized for V2X communication over LTE-Uu using existing unicast routing.

- Occurrence: ZeroOrOne
- Format: node
- Access Types: Get, Replace
- Values: N/A

5.6.61 <X>/V2XoverLTEUu/AuthorizedPLMNs/<X>/ V2XServiceIdentifierRelated/IPUnicastRoutingV2XServiceList/<X>

This node acts as a placeholder for a V2X service identified by a V2X service identifier, authorized for V2X communication over LTE-Uu using existing unicast routing.

- Occurrence: ZeroOrMore
- Format: node
- Access Types: Get, Replace
- Values: N/A

5.6.62 <X>/V2XoverLTEUu/AuthorizedPLMNs/<X>/ V2XServiceIdentifierRelated/IPUnicastRoutingV2XServiceList/<X> V2XServiceIdentifier

This node is the same as the node defined in subclause 5.5.22.

5.7 <X>/Ext

The Ext is an interior node for where the vendor specific information about the V2X communication provisioning MO is being placed (vendor meaning application vendor, device vendor etc.). Usually the vendor extension is identified by vendor specific name under the ext node. The tree structure under the vendor identifier is not defined and can therefore include one or more un-standardized sub-trees.

- Occurrence: ZeroOrOne
- Format: node
- Access Types: Get
- Values: N/A

Annex A (informative): V2X Communication Provisioning MO DDF

This DDF is the standardized minimal set. A vendor can define its own DDF for the complete device. This DDF can include more features than this minimal standardized version.

```
<?xml version="1.0" encoding="UTF-8"?>
<!DOCTYPE MgmtTree PUBLIC "-//OMA//DTD-DM-DDF 1.2//EN"
"http://www.openmobilealliance.org/tech/DTD/dm_ddf-v1_2.dtd">

<MgmtTree>
  <VerDTD>1.2</VerDTD>
  <Man>--The device manufacturer--</Man>
  <Mod>--The device model--</Mod>

  <Node>
    <NodeName/>
    <DFProperties>
      <AccessType>
        <Get/>
      </AccessType>
      <Description>V2X Communication Provisioning</Description>
      <DFFormat>
        <node/>
      </DFFormat>
      <Occurrence>
        <OneOrMore/>
      </Occurrence>
      <DFTitle>The V2X Communication Provisioning Management Object.</DFTitle>
      <DFType>
        <DDFName/>urn:oma:mo:ext-3gpp-V2X-communication-provisioning:1.0<DDFName/>
      </DFType>
    </DFProperties>

    <Node>
      <NodeName>Name</NodeName>
      <DFProperties>
        <AccessType>
          <Get/>
        </AccessType>
        <DFFormat>
          <chr/>
        </DFFormat>
        <Occurrence>
          <One/>
        </Occurrence>
        <DFTitle>User displayable name for the node.</DFTitle>
        <DFType>
          <MIME>text/plain</MIME>
        </DFType>
      </DFProperties>
    </Node>

    <Node>
      <NodeName>V2XProvisioning</NodeName>
      <!-- The V2XProvisioning node starts here. -->
      <DFProperties>
        <AccessType>
          <Get/>
          <Replace/>
        </AccessType>
        <DFFormat>
          <node/>
        </DFFormat>
        <Occurrence>
          <One/>
        </Occurrence>
        <DFTitle>Configuration parameters for V2X provisioning.</DFTitle>
        <DFType>
          <DDFName/>
        </DFType>
      </DFProperties>

    <Node>
      <NodeName>V2XControlFunctionAddress</NodeName>
```

```

    <DFProperties>
      <AccessType>
        <Get/>
        <Replace/>
      </AccessType>
      <DFFormat>
        <chr/>
      </DFFormat>
      <Occurrence>
        <ZeroOrOne/>
      </Occurrence>
      <DFTitle>The V2X control function address.</DFTitle>
      <DFType>
        <DDFName/>
      </DFType>
    </DFProperties>
  </Node>

  <Node>
    <NodeName>ToConRefs</NodeName>
    <DFProperties>
      <AccessType>
        <Get/>
        <Replace/>
      </AccessType>
      <DFFormat>
        <node/>
      </DFFormat>
      <Occurrence>
        <ZeroOrOne/>
      </Occurrence>
      <DFTitle>collection of connectivity definitions.</DFTitle>
      <DFType>
        <DDFName/>
      </DFType>
    </DFProperties>

    <Node>
      <NodeName/>
      <DFProperties>
        <AccessType>
          <Get/>
          <Replace/>
        </AccessType>
        <DFFormat>
          <node/>
        </DFFormat>
        <Occurrence>
          <OneOrMore/>
        </Occurrence>
        <DFTitle>The name node for one or more connectivity parameters.</DFTitle>
        <DFType>
          <DDFName/>
        </DFType>
      </DFProperties>

      <Node>
        <NodeName>ConRef</NodeName>
        <DFProperties>
          <AccessType>
            <Get/>
            <Replace/>
          </AccessType>
          <DFFormat>
            <chr/>
          </DFFormat>
          <Occurrence>
            <One/>
          </Occurrence>
          <DFTitle> Linkage to connectivity parameters.</DFTitle>
          <DFType>
            <MIME>text/plain</MIME>
          </DFType>
        </DFProperties>
      </Node>
    </Node>
  </Node>
</Node>

```

```

<Node>
  <NodeName>V2XoverPC5</NodeName>
  <!-- The V2XoverPC5 node starts here. -->
  <DFProperties>
    <AccessType>
      <Get/>
      <Replace/>
    </AccessType>
    <DFFormat>
      <node/>
    </DFFormat>
    <Occurrence>
      <One/>
    </Occurrence>
    <DFTitle>Configuration parameters for V2X communication over PC5.</DFTitle>
    <DFType>
      <DDFName/>
    </DFType>
  </DFProperties>

  <Node>
    <NodeName>Expiration</NodeName>
    <DFProperties>
      <AccessType>
        <Get/>
        <Replace/>
      </AccessType>
      <DFFormat>
        <int/>
      </DFFormat>
      <Occurrence>
        <One/>
      </Occurrence>
      <DFTitle>Expiration time of validity.</DFTitle>
      <DFType>
        <DDFName/>
      </DFType>
    </DFProperties>
  </Node>

  <Node>
    <NodeName>ServedByEUTRAN</NodeName>
    <DFProperties>
      <AccessType>
        <Get/>
        <Replace/>
      </AccessType>
      <DFFormat>
        <node/>
      </DFFormat>
      <Occurrence>
        <One/>
      </Occurrence>
      <DFTitle>Configuration parameters for V2X communication over PC5 when served by
E-UTRAN for V2X communication.</DFTitle>
      <DFType>
        <DDFName/>
      </DFType>
    </DFProperties>

    <Node>
      <NodeName>AuthorizedPLMNs</NodeName>
      <DFProperties>
        <AccessType>
          <Get/>
          <Replace/>
        </AccessType>
        <DFFormat>
          <node/>
        </DFFormat>
        <Occurrence>
          <One/>
        </Occurrence>
        <DFTitle>Authorization per PLMN policies for V2X communication over PC5 when
served by E-UTRAN for V2X communication.</DFTitle>
        <DFType>
          <DDFName/>
        </DFType>
      </DFProperties>
    </Node>
  </Node>

```

```

    </DFType>
  </DFProperties>

  <Node>
    <NodeName></NodeName>
    <DFProperties>
      <AccessType>
        <Get/>
        <Replace/>
      </AccessType>
      <DFFormat>
        <node/>
      </DFFormat>
      <Occurrence>
        <ZeroOrMore/>
      </Occurrence>
      <DFType>
        <DDFName></DDFName>
      </DFType>
    </DFProperties>

    <Node>
      <NodeName>PLMN</NodeName>
      <DFProperties>
        <AccessType>
          <Get/>
          <Replace/>
        </AccessType>
        <DFFormat>
          <chr/>
        </DFFormat>
        <Occurrence>
          <One/>
        </Occurrence>
        <DFTitle>PLMN code.</DFTitle>
        <DFType>
          <MIME>text/plain</MIME>
        </DFType>
      </DFProperties>
    </Node>
  </Node>
</Node>

<Node>
  <NodeName>NotServedByEUTRAN</NodeName>
  <DFProperties>
    <AccessType>
      <Get/>
      <Replace/>
    </AccessType>
    <DFFormat>
      <node/>
    </DFFormat>
    <Occurrence>
      <One/>
    </Occurrence>
    <DFTitle>Configuration parameters for V2X communication over PC5 when not served
by E-UTRAN for V2X communication.</DFTitle>
    <DFType>
      <DDFName/>
    </DFType>
  </DFProperties>

  <Node>
    <NodeName>Authorized</NodeName>
    <DFProperties>
      <AccessType>
        <Get/>
        <Replace/>
      </AccessType>
      <DFFormat>
        <bool/>
      </DFFormat>
      <Occurrence>
        <One/>
      </Occurrence>
    </DFProperties>
  </Node>

```

```

        <DFTitle>Authorization for V2X communication over PC5 when not served by E-
UTRAN for V2X communication.</DFTitle>
        <DFType>
            <DDFName/>
        </DFType>
    </DFProperties>
</Node>

<Node>
    <NodeName>RadioParameters</NodeName>
    <DFProperties>
        <AccessType>
            <Get/>
            <Replace/>
        </AccessType>
        <DFFormat>
            <node/>
        </DFFormat>
        <Occurrence>
            <ZeroOrMore/>
        </Occurrence>
        <DFTitle>Radio parameters for V2X communication over PC5 when not served by
E-UTRAN for V2X communication.</DFTitle>
        <DFType>
            <DDFName/>
        </DFType>
    </DFProperties>

    <Node>
        <NodeName></NodeName>
        <DFProperties>
            <AccessType>
                <Get/>
                <Replace/>
            </AccessType>
            <DFFormat>
                <node/>
            </DFFormat>
            <Occurrence>
                <OneOrMore/>
            </Occurrence>
            <DFType>
                <DDFName></DDFName>
            </DFType>
        </DFProperties>

    <Node>
        <NodeName>RadioParametersContents</NodeName>
        <DFProperties>
            <AccessType>
                <Get/>
                <Replace/>
            </AccessType>
            <DFFormat>
                <bin/>
            </DFFormat>
            <Occurrence>
                <One/>
            </Occurrence>
            <DFTitle>Radio parameters defined by 3GPP RAN WG.</DFTitle>
            <DFType>
                <MIME>text/plain</MIME>
            </DFType>
        </DFProperties>
    </Node>

    <Node>
        <NodeName>GeographicalArea</NodeName>
        <DFProperties>
            <AccessType>
                <Get/>
                <Replace/>
            </AccessType>
            <DFFormat>
                <node/>
            </DFFormat>
            <Occurrence>
                <One/>
            </Occurrence>
        </DFProperties>
    </Node>

```



```

    </Occurrence>
    <DFTitle>Geographical Area description.</DFTitle>
    <DFType>
      <MIME>text/plain</MIME>
    </DFType>
  </DFProperties>

  <Node>
    <NodeName>Polygon</NodeName>
    <DFProperties>
      <AccessType>
        <Get/>
        <Replace/>
      </AccessType>
      <DFFormat>
        <node/>
      </DFFormat>
      <Occurrence>
        <One/>
      </Occurrence>
      <DFTitle>Polygon Area description.</DFTitle>
      <DFType>
        <DDFName/>
      </DFType>
    </DFProperties>

  <Node>
    <NodeName></NodeName>
    <DFProperties>
      <AccessType>
        <Get/>
        <Replace/>
      </AccessType>
      <DFFormat>
        <node/>
      </DFFormat>
      <Occurrence>
        <OneOrMore/>
      </Occurrence>
      <DFType>
        <DDFName></DDFName>
      </DFType>
    </DFProperties>

  <Node>
    <NodeName>Coordinates</NodeName>
    <DFProperties>
      <AccessType>
        <Get/>
        <Replace/>
      </AccessType>
      <DFFormat>
        <node/>
      </DFFormat>
      <Occurrence>
        <One/>
      </Occurrence>
      <DFTitle>Descriptions for geographical
coordinates</DFTitle>
      <DFType>
        <MIME>text/plain</MIME>
      </DFType>
    </DFProperties>

  <Node>
    <NodeName></NodeName>
    <DFProperties>
      <AccessType>
        <Get/>
        <Replace/>
      </AccessType>
      <DFFormat>
        <node/>
      </DFFormat>
      <Occurrence>
        <OneOrMore/>
      </Occurrence>
      <DFType>

```

```

        <DDFName></DDFName>
      </DFType>
    </DFProperties>
  </Node>
  <Node>
    <NodeName>Latitude</NodeName>
    <DFProperties>
      <AccessType>
        <Get/>
        <Replace/>
      </AccessType>
      <DFFormat>
        <bin/>
      </DFFormat>
      <Occurrence>
        <One/>
      </Occurrence>
      <DFTitle>coordinate latitude</DFTitle>
      <DFType>
        <MIME>text/plain</MIME>
      </DFType>
    </DFProperties>
  </Node>
  <Node>
    <NodeName>Longitude</NodeName>
    <DFProperties>
      <AccessType>
        <Get/>
        <Replace/>
      </AccessType>
      <DFFormat>
        <bin/>
      </DFFormat>
      <Occurrence>
        <One/>
      </Occurrence>
      <DFTitle>coordinate longitude</DFTitle>
      <DFType>
        <MIME>text/plain</MIME>
      </DFType>
    </DFProperties>
  </Node>
</Node>
</Node>
</Node>
</Node>
  <Node>
    <NodeName>OperatorManaged</NodeName>
    <DFProperties>
      <AccessType>
        <Get/>
        <Replace/>
      </AccessType>
      <DFFormat>
        <bool/>
      </DFFormat>
      <Occurrence>
        <One/>
      </Occurrence>
      <DFTitle>Whether the radio parameters are operator managed or non-
operator managed.</DFTitle>
      <DFType>
        <MIME>text/plain</MIME>
      </DFType>
    </DFProperties>
  </Node>
</Node>
</Node>
  <Node>
    <NodeName>AuthorizedV2XServiceList</NodeName>
    <DFProperties>
      <AccessType>

```

```

        <Get />
        <Replace />
    </AccessType>
    <DFFormat>
        <node />
    </DFFormat>
    <Occurrence>
        <One />
    </Occurrence>
    <DFTitle>Authorized V2X services for V2X communication over PC5.</DFTitle>
    <DFType>
        <DDFName />
    </DFType>
</DFProperties>

<Node>
    <NodeName></NodeName>
    <DFProperties>
        <AccessType>
            <Get />
            <Replace />
        </AccessType>
        <DFFormat>
            <node />
        </DFFormat>
        <Occurrence>
            <ZeroOrMore />
        </Occurrence>
        <DFType>
            <DDFName></DDFName>
        </DFType>
    </DFProperties>

    <Node>
        <NodeName>V2XServiceIdentifier</NodeName>
        <DFProperties>
            <AccessType>
                <Get />
                <Replace />
            </AccessType>
            <DFFormat>
                <int />
            </DFFormat>
            <Occurrence>
                <One />
            </Occurrence>
            <DFTitle>V2X service identifier.</DFTitle>
            <DFType>
                <DDFName></DDFName>
            </DFType>
        </DFProperties>
    </Node>

    <Node>
        <NodeName>DestinationLayer2ID</NodeName>
        <DFProperties>
            <AccessType>
                <Get />
                <Replace />
            </AccessType>
            <DFFormat>
                <bin />
            </DFFormat>
            <Occurrence>
                <One />
            </Occurrence>
            <DFTitle>Layer 2 ID for V2X communication over PC5.</DFTitle>
            <DFType>
                <DDFName></DDFName>
            </DFType>
        </DFProperties>
    </Node>
</Node>

<Node>
    <NodeName>PPPPtoPDBMappingRule</NodeName>
    <DFProperties>

```

```

    <AccessType>
      <Get/>
      <Replace/>
    </AccessType>
    <DFFormat>
      <node/>
    </DFFormat>
    <Occurrence>
      <ZeroOrOne/>
    </Occurrence>
    <DFTitle>Mapping rules between PPPP and PDB.</DFTitle>
    <DFType>
      <DDFName/>
    </DFType>
  </DFProperties>
</Node>
<Node>
  <NodeName></NodeName>
  <DFProperties>
    <AccessType>
      <Get/>
      <Replace/>
    </AccessType>
    <DFFormat>
      <node/>
    </DFFormat>
    <Occurrence>
      <OneOrMore/>
    </Occurrence>
    <DFType>
      <DDFName></DDFName>
    </DFType>
  </DFProperties>
</Node>
<Node>
  <NodeName>ProSePerPacketPriority</NodeName>
  <DFProperties>
    <AccessType>
      <Get/>
      <Replace/>
    </AccessType>
    <DFFormat>
      <int/>
    </DFFormat>
    <Occurrence>
      <One/>
    </Occurrence>
    <DFTitle>PPPP value used in the mapping rule.</DFTitle>
    <DFType>
      <DDFName/>
    </DFType>
  </DFProperties>
</Node>
<Node>
  <NodeName>PacketDelayBudget</NodeName>
  <DFProperties>
    <AccessType>
      <Get/>
      <Replace/>
    </AccessType>
    <DFFormat>
      <int/>
    </DFFormat>
    <Occurrence>
      <One/>
    </Occurrence>
    <DFTitle>PDB used in the mapping rule.</DFTitle>
    <DFType>
      <DDFName/>
    </DFType>
  </DFProperties>
</Node>
</Node>
<Node>
  <NodeName>DefaultDestinationLayer2ID</NodeName>

```

```

    <DFProperties>
      <AccessType>
        <Get />
        <Replace />
      </AccessType>
      <DFFormat>
        <bin />
      </DFFormat>
      <Occurrence>
        <ZeroOrOne />
      </Occurrence>
      <DFTitle>Default destination Layer-2 ID for V2X communication over
PC5.</DFTitle>
      <DFType>
        <DDFName />
      </DFType>
    </DFProperties>
  </Node>

  <Node>
    <NodeName>PrivacyConfig</NodeName>
    <DFProperties>
      <AccessType>
        <Get />
        <Replace />
      </AccessType>
      <DFFormat>
        <node />
      </DFFormat>
      <Occurrence>
        <ZeroOrOne />
      </Occurrence>
      <DFTitle>Configuration for privacy of V2X communication over PC5.</DFTitle>
      <DFType>
        <DDFName />
      </DFType>
    </DFProperties>

    <Node>
      <NodeName>TimerT5000</NodeName>
      <DFProperties>
        <AccessType>
          <Get />
          <Replace />
        </AccessType>
        <DFFormat>
          <int />
        </DFFormat>
        <Occurrence>
          <One />
        </Occurrence>
        <DFTitle>Timer T5000 to ensure privacy of V2X communication over
PC5.</DFTitle>
        <DFType>
          <DDFName />
        </DFType>
      </DFProperties>
    </Node>

    <Node>
      <NodeName>V2XServicePrivacyList</NodeName>
      <DFProperties>
        <AccessType>
          <Get />
          <Replace />
        </AccessType>
        <DFFormat>
          <node />
        </DFFormat>
        <Occurrence>
          <One />
        </Occurrence>
        <DFTitle>List of V2X services which require privacy for V2X communication
over PC5.</DFTitle>
        <DFType>
          <DDFName />
        </DFType>
      </DFProperties>

```

```

<Node>
  <NodeName></NodeName>
  <DFProperties>
    <AccessType>
      <Get/>
      <Replace/>
    </AccessType>
    <DFFormat>
      <node/>
    </DFFormat>
    <Occurrence>
      <ZeroOrMore/>
    </Occurrence>
    <DFType>
      <DDFName></DDFName>
    </DFType>
  </DFProperties>

  <Node>
    <NodeName>V2XServiceIdentifier</NodeName>
    <DFProperties>
      <AccessType>
        <Get/>
        <Replace/>
      </AccessType>
      <DFFormat>
        <int/>
      </DFFormat>
      <Occurrence>
        <One/>
      </Occurrence>
      <DFTitle>V2X service identifier.</DFTitle>
      <DFType>
        <DDFName></DDFName>
      </DFType>
    </DFProperties>
  </Node>

  <Node>
    <NodeName>GeographicalAreaList</NodeName>
    <DFProperties>
      <AccessType>
        <Get/>
        <Replace/>
      </AccessType>
      <DFFormat>
        <node/>
      </DFFormat>
      <Occurrence>
        <ZeroOrOne/>
      </Occurrence>
      <DFTitle>List of geographical areas in which the V2X service
requires privacy for V2X communication over PC5.</DFTitle>
      <DFType>
        <DDFName></DDFName>
      </DFType>
    </DFProperties>

  <Node>
    <NodeName></NodeName>
    <DFProperties>
      <AccessType>
        <Get/>
        <Replace/>
      </AccessType>
      <DFFormat>
        <node/>
      </DFFormat>
      <Occurrence>
        <ZeroOrMore/>
      </Occurrence>
      <DFType>
        <DDFName></DDFName>
      </DFType>
    </DFProperties>
  </Node>

```

```

<NodeName>GeographicalArea</NodeName>
<DFProperties>
  <AccessType>
    <Get/>
    <Replace/>
  </AccessType>
  <DFFormat>
    <node/>
  </DFFormat>
  <Occurrence>
    <One/>
  </Occurrence>
  <DFTitle>Geographical Area description.</DFTitle>
  <DFType>
    <MIME>text/plain</MIME>
  </DFType>
</DFProperties>

<Node>
  <NodeName>Polygon</NodeName>
  <DFProperties>
    <AccessType>
      <Get/>
      <Replace/>
    </AccessType>
    <DFFormat>
      <node/>
    </DFFormat>
    <Occurrence>
      <One/>
    </Occurrence>
    <DFTitle>Polygon Area description.</DFTitle>
    <DFType>
      <DDFName/>
    </DFType>
  </DFProperties>

<Node>
  <NodeName></NodeName>
  <DFProperties>
    <AccessType>
      <Get/>
      <Replace/>
    </AccessType>
    <DFFormat>
      <node/>
    </DFFormat>
    <Occurrence>
      <OneOrMore/>
    </Occurrence>
    <DFType>
      <DDFName></DDFName>
    </DFType>
  </DFProperties>

<Node>
  <NodeName>Coordinates</NodeName>
  <DFProperties>
    <AccessType>
      <Get/>
      <Replace/>
    </AccessType>
    <DFFormat>
      <node/>
    </DFFormat>
    <Occurrence>
      <One/>
    </Occurrence>
    <DFTitle>Descriptions for geographical
coordinates</DFTitle>
    <DFType>
      <MIME>text/plain</MIME>
    </DFType>
  </DFProperties>

<Node>
  <NodeName></NodeName>
  <DFProperties>

```

```

    <AccessType>
      <Get/>
      <Replace/>
    </AccessType>
    <DFFormat>
      <node/>
    </DFFormat>
    <Occurrence>
      <OneOrMore/>
    </Occurrence>
    <DFType>
      <DDFName></DDFName>
    </DFType>
  </DFProperties>

  <Node>
    <NodeName>Latitude</NodeName>
    <DFProperties>
      <AccessType>
        <Get/>
        <Replace/>
      </AccessType>
      <DFFormat>
        <bin/>
      </DFFormat>
      <Occurrence>
        <One/>
      </Occurrence>
      <DFTitle>coordinate latitude</DFTitle>
      <DFType>
        <MIME>text/plain</MIME>
      </DFType>
    </DFProperties>
  </Node>

  <Node>
    <NodeName>Longitude</NodeName>
    <DFProperties>
      <AccessType>
        <Get/>
        <Replace/>
      </AccessType>
      <DFFormat>
        <bin/>
      </DFFormat>
      <Occurrence>
        <One/>
      </Occurrence>
      <DFTitle>coordinate longitude</DFTitle>
      <DFType>
        <MIME>text/plain</MIME>
      </DFType>
    </DFProperties>
  </Node>
</Node>
</Node>
</Node>
</Node>
</Node>
</Node>

  </Node>
</Node>
</Node>
</Node>
</Node>
</Node>
</Node>
</Node>

  <Node>
    <NodeName>V2XServiceIDtoV2XFrequencyMappingRule</NodeName>
    <DFProperties>
      <AccessType>
        <Get/>
        <Replace/>
      </AccessType>
      <DFFormat>

```



```

        <node/>
      </DFFormat>
    <Occurrence>
      <ZeroOrOne/>
    </Occurrence>
  <DFTitle>mapping rules between the V2X service identifier and the V2X
frequency.</DFTitle>
  <DFType>
    <DDFName/>
  </DFType>
</DFProperties>

<Node>
  <NodeName></NodeName>
  <DFProperties>
    <AccessType>
      <Get/>
      <Replace/>
    </AccessType>
    <DFFormat>
      <node/>
    </DFFormat>
    <Occurrence>
      <OneOrMore/>
    </Occurrence>
    <DFType>
      <DDFName></DDFName>
    </DFType>
  </DFProperties>

  <Node>
    <NodeName>V2XServiceIdentifier</NodeName>
    <DFProperties>
      <AccessType>
        <Get/>
        <Replace/>
      </AccessType>
      <DFFormat>
        <int/>
      </DFFormat>
      <Occurrence>
        <One/>
      </Occurrence>
      <DFTitle>V2X service identifier used in the mapping rule.</DFTitle>
      <DFType>
        <DDFName></DDFName>
      </DFType>
    </DFProperties>
  </Node>

  <Node>
    <NodeName>V2XFrequency</NodeName>
    <DFProperties>
      <AccessType>
        <Get/>
        <Replace/>
      </AccessType>
      <DFFormat>
        <node/>
      </DFFormat>
      <Occurrence>
        <One/>
      </Occurrence>
      <DFTitle> V2X frequencies used for V2X communication over the
PC5.</DFTitle>
      <DFType>
        <DDFName/>
      </DFType>
    </DFProperties>

    <Node>
      <NodeName></NodeName>
      <DFProperties>
        <AccessType>
          <Get/>
          <Replace/>
        </AccessType>
        <DFFormat>

```

```

        <node/>
    </DFFormat>
    <Occurrence>
        <OneOrMore/>
    </Occurrence>
    <DFType>
        <DDFName></DDFName>
    </DFType>
</DFProperties>

<Node>
    <NodeName>V2XFrequency</NodeName>
    <DFProperties>
        <AccessType>
            <Get/>
            <Replace/>
        </AccessType>
        <DFFormat>
            <int/>
        </DFFormat>
        <Occurrence>
            <One/>
        </Occurrence>
        <DFTitle>V2X frequency used in the mapping rule.</DFTitle>
        <DFType>
            <DDFName/>
        </DFType>
    </DFProperties>
</Node>
</Node>

<Node>
    <NodeName>GeographicalArea</NodeName>
    <DFProperties>
        <AccessType>
            <Get/>
            <Replace/>
        </AccessType>
        <DFFormat>
            <node/>
        </DFFormat>
        <Occurrence>
            <One/>
        </Occurrence>
        <DFTitle>Geographical Area description.</DFTitle>
        <DFType>
            <MIME>text/plain</MIME>
        </DFType>
    </DFProperties>

    <Node>
        <NodeName>Polygon</NodeName>
        <DFProperties>
            <AccessType>
                <Get/>
                <Replace/>
            </AccessType>
            <DFFormat>
                <node/>
            </DFFormat>
            <Occurrence>
                <One/>
            </Occurrence>
            <DFTitle>Polygon Area description.</DFTitle>
            <DFType>
                <DDFName/>
            </DFType>
        </DFProperties>

    <Node>
        <NodeName></NodeName>
        <DFProperties>
            <AccessType>
                <Get/>
                <Replace/>
            </AccessType>
            <DFFormat>

```

```

    <node/>
  </DFFormat>
  <Occurrence>
    <OneOrMore/>
  </Occurrence>
  <DFType>
    <DDFName></DDFName>
  </DFType>
</DFProperties>
<Node>
  <NodeName>Coordinates</NodeName>
  <DFProperties>
    <AccessType>
      <Get/>
      <Replace/>
    </AccessType>
    <DFFormat>
      <node/>
    </DFFormat>
    <Occurrence>
      <One/>
    </Occurrence>
    <DFTitle>Descriptions for geographical coordinates</DFTitle>
    <DFType>
      <MIME>text/plain</MIME>
    </DFType>
  </DFProperties>
  <Node>
    <NodeName></NodeName>
    <DFProperties>
      <AccessType>
        <Get/>
        <Replace/>
      </AccessType>
      <DFFormat>
        <node/>
      </DFFormat>
      <Occurrence>
        <OneOrMore/>
      </Occurrence>
      <DFType>
        <DDFName></DDFName>
      </DFType>
    </DFProperties>
    <Node>
      <NodeName>Latitude</NodeName>
      <DFProperties>
        <AccessType>
          <Get/>
          <Replace/>
        </AccessType>
        <DFFormat>
          <bin/>
        </DFFormat>
        <Occurrence>
          <One/>
        </Occurrence>
        <DFTitle>coordinate latitude</DFTitle>
        <DFType>
          <MIME>text/plain</MIME>
        </DFType>
      </DFProperties>
    </Node>
    <Node>
      <NodeName>Longitude</NodeName>
      <DFProperties>
        <AccessType>
          <Get/>
          <Replace/>
        </AccessType>
        <DFFormat>
          <bin/>
        </DFFormat>
        <Occurrence>
          <One/>
        </Occurrence>
        <DFTitle>coordinate longitude</DFTitle>

```

```

    <DFType>
      <MIME>text/plain</MIME>
    </DFType>
  </DFProperties>
</Node>
</Node>
</Node>
</Node>
</Node>
</Node>
</Node>
</Node>
</Node>
<Node>
  <nodeName>V2XServiceIDtoTxProfileMappingRule</nodeName>
  <DFProperties>
    <AccessType>
      <Get/>
      <Replace/>
    </AccessType>
    <DFFormat>
      <node/>
    </DFFormat>
    <Occurrence>
      <ZeroOrOne/>
    </Occurrence>
    <DFTitle>mapping rules between the V2X service identifier and Tx
Profile.</DFTitle>
  <DFType>
    <DDFName/>
  </DFType>
</DFProperties>

  <Node>
    <nodeName></nodeName>
    <DFProperties>
      <AccessType>
        <Get/>
        <Replace/>
      </AccessType>
      <DFFormat>
        <node/>
      </DFFormat>
      <Occurrence>
        <OneOrMore/>
      </Occurrence>
      <DFType>
        <DDFName></DDFName>
      </DFType>
    </DFProperties>

  <Node>
    <nodeName>V2XServiceIdentifier</nodeName>
    <DFProperties>
      <AccessType>
        <Get/>
        <Replace/>
      </AccessType>
      <DFFormat>
        <int/>
      </DFFormat>
      <Occurrence>
        <One/>
      </Occurrence>
      <DFTitle>V2X service identifier used in the mapping rule.</DFTitle>
      <DFType>
        <DDFName></DDFName>
      </DFType>
    </DFProperties>
  </Node>

  <Node>
    <nodeName>TxProfile</nodeName>
    <DFProperties>
      <AccessType>
        <Get/>
        <Replace/>
      </AccessType>

```

```

        <DFFormat>
          <int/>
        </DFFormat>
        <Occurrence>
          <One/>
        </Occurrence>
        <DFTitle>Tx profile used for V2X communication over PC5.</DFTitle>
        <DFType>
          <DDFName/>
        </DFType>
      </DFProperties>
    </Node>
  </Node>
</Node>
<Node>
  <NodeName>PPPRAuthorizationList</NodeName>
  <DFProperties>
    <AccessType>
      <Get/>
      <Replace/>
    </AccessType>
    <DFFormat>
      <node/>
    </DFFormat>
    <Occurrence>
      <ZeroOrOne/>
    </Occurrence>
    <DFTitle>list of the V2X services authorized for ProSe Per-Packet Reliability
(PPPR).</DFTitle>
    <DFType>
      <DDFName/>
    </DFType>
  </DFProperties>
  <Node>
    <NodeName></NodeName>
    <DFProperties>
      <AccessType>
        <Get/>
        <Replace/>
      </AccessType>
      <DFFormat>
        <node/>
      </DFFormat>
      <Occurrence>
        <OneOrMore/>
      </Occurrence>
      <DFType>
        <DDFName></DDFName>
      </DFType>
    </DFProperties>
  </Node>
  <Node>
    <NodeName>V2XServiceIdentifier</NodeName>
    <DFProperties>
      <AccessType>
        <Get/>
        <Replace/>
      </AccessType>
      <DFFormat>
        <int/>
      </DFFormat>
      <Occurrence>
        <One/>
      </Occurrence>
      <DFTitle>V2X service identifier of an entry of the list of the V2X
services authorized for ProSe Per-Packet Reliability (PPPR).</DFTitle>
      <DFType>
        <DDFName></DDFName>
      </DFType>
    </DFProperties>
  </Node>
  <Node>
    <NodeName>PPPRValue</NodeName>
    <DFProperties>
      <AccessType>
        <Get/>

```

```

        <Replace/>
      </AccessType>
    <DFFormat>
      <int/>
    </DFFormat>
    <Occurrence>
      <One/>
    </Occurrence>
    <DFTitle>PPPR value of an entry of the list of the V2X services
authorized for ProSe Per-Packet Reliability (PPPR).</DFTitle>
    <DFType>
      <DDFName/>
    </DFType>
  </DFProperties>
</Node>
</Node>
</Node>
<Node>
  <NodeName>V2XoverNRPC5</NodeName>
  <!-- The V2XoverNRPC5 node starts here. -->
  <DFProperties>
    <AccessType>
      <Get/>
      <Replace/>
    </AccessType>
    <DFFormat>
      <node/>
    </DFFormat>
    <Occurrence>
      <ZeroOrOne/>
    </Occurrence>
    <DFTitle>Configuration parameters for V2X communication over NR-PC5.</DFTitle>
    <DFType>
      <DDFName/>
    </DFType>
  </DFProperties>

  <Node> <!--V2XServiceIDtoV2XNRFrequencyMappingRule starts-->
    <NodeName>V2XServiceIDtoV2XNRFrequencyMappingRule</NodeName>
    <DFProperties>
      <AccessType>
        <Get/>
        <Replace/>
      </AccessType>
      <DFFormat>
        <node/>
      </DFFormat>
      <Occurrence>
        <ZeroOrOne/>
      </Occurrence>
      <DFTitle>Mapping rules between the V2X service identifier and V2X NR
frequency for V2X communication over the NR-PC5.</DFTitle>
      <DFType>
        <DDFName/>
      </DFType>
    </DFProperties>

    <Node>
      <NodeName/>
      <DFProperties>
        <AccessType>
          <Get/>
          <Replace/>
        </AccessType>
        <DFFormat>
          <node/>
        </DFFormat>
        <Occurrence>
          <OneOrMore/>
        </Occurrence>
        <DFType>
          <DDFName/>
        </DFType>
      </DFProperties>

    <Node>
      <NodeName>V2XServiceIdentifier</NodeName>

```

```

    <DFProperties>
      <AccessType>
        <Get />
        <Replace />
      </AccessType>
      <DFFormat>
        <int />
      </DFFormat>
      <Occurrence>
        <One />
      </Occurrence>
      <DFTitle>V2X service identifier used in the mapping rule.</DFTitle>
      <DFType>
        <DDFName />
      </DFType>
    </DFProperties>
  </Node>

  <Node>
    <NodeName>V2XNRFrequency</NodeName>
    <DFProperties>
      <AccessType>
        <Get />
        <Replace />
      </AccessType>
      <DFFormat>
        <node />
      </DFFormat>
      <Occurrence>
        <One />
      </Occurrence>
      <DFTitle>V2X NR frequencies used for V2X communication over the NR-
PC5.</DFTitle>
      <DFType>
        <DDFName />
      </DFType>
    </DFProperties>

    <Node>
      <NodeName />
      <DFProperties>
        <AccessType>
          <Get />
          <Replace />
        </AccessType>
        <DFFormat>
          <node />
        </DFFormat>
        <Occurrence>
          <OneOrMore />
        </Occurrence>
        <DFType>
          <DDFName />
        </DFType>
      </DFProperties>

    <Node>
      <NodeName>V2XNRFrequency</NodeName>
      <DFProperties>
        <AccessType>
          <Get />
          <Replace />
        </AccessType>
        <DFFormat>
          <int />
        </DFFormat>
        <Occurrence>
          <One />
        </Occurrence>
        <DFTitle>ARFCN-ValueNR defined by 3GPP RAN WG.</DFTitle>
        <DFType>
          <MIME>text/plain</MIME>
        </DFType>
      </DFProperties>
    </Node>
  </Node>
</Node>

```

```

<Node>
  <NodeName>GeographicalArea</NodeName>
  <DFProperties>
    <AccessType>
      <Get />
      <Replace />
    </AccessType>
    <DFFormat>
      <node />
    </DFFormat>
    <Occurrence>
      <One />
    </Occurrence>
    <DFTitle>Geographical Area description.</DFTitle>
    <DFType>
      <MIME>text/plain</MIME>
    </DFType>
  </DFProperties>

  <Node>
    <NodeName>Polygon</NodeName>
    <DFProperties>
      <AccessType>
        <Get />
        <Replace />
      </AccessType>
      <DFFormat>
        <node />
      </DFFormat>
      <Occurrence>
        <One />
      </Occurrence>
      <DFTitle>Polygon Area description.</DFTitle>
      <DFType>
        <DDFName />
      </DFType>
    </DFProperties>

    <Node>
      <NodeName />
      <DFProperties>
        <AccessType>
          <Get />
          <Replace />
        </AccessType>
        <DFFormat>
          <node />
        </DFFormat>
        <Occurrence>
          <OneOrMore />
        </Occurrence>
        <DFType>
          <DDFName />
        </DFType>
      </DFProperties>

      <Node>
        <NodeName>Coordinates</NodeName>
        <DFProperties>
          <AccessType>
            <Get />
            <Replace />
          </AccessType>
          <DFFormat>
            <node />
          </DFFormat>
          <Occurrence>
            <One />
          </Occurrence>
          <DFTitle>Descriptions for geographical
coordinates</DFTitle>
          <DFType>
            <MIME>text/plain</MIME>
          </DFType>
        </DFProperties>

      <Node>
        <NodeName />

```



```

    <DFProperties>
      <AccessType>
        <Get/>
        <Replace/>
      </AccessType>
      <DFFormat>
        <node/>
      </DFFormat>
      <Occurrence>
        <OneOrMore/>
      </Occurrence>
      <DFType>
        <DDFName/>
      </DFType>
    </DFProperties>

    <Node>
      <NodeName>Latitude</NodeName>
      <DFProperties>
        <AccessType>
          <Get/>
          <Replace/>
        </AccessType>
        <DFFormat>
          <bin/>
        </DFFormat>
        <Occurrence>
          <One/>
        </Occurrence>
        <DFTitle>Coordinate Latitude</DFTitle>
        <DFType>
          <MIME>text/plain</MIME>
        </DFType>
      </DFProperties>
    </Node>

    <Node>
      <NodeName>Longitude</NodeName>
      <DFProperties>
        <AccessType>
          <Get/>
          <Replace/>
        </AccessType>
        <DFFormat>
          <bin/>
        </DFFormat>
        <Occurrence>
          <One/>
        </Occurrence>
        <DFTitle>Coordinate Longitude</DFTitle>
        <DFType>
          <MIME>text/plain</MIME>
        </DFType>
      </DFProperties>
    </Node>
  </Node>
</Node>
</Node>
</Node>
</Node>
</Node>
</Node>
</Node>
</Node>
<Node> <!--V2XServiceID_to_BC_DestL2ID_MappingRule-->
  <NodeName>V2XServiceIDtoBroadcastDestinationLayer2IDMappingRule</NodeName>
  <DFProperties>
    <AccessType>
      <Get/>
      <Replace/>
    </AccessType>
    <DFFormat>
      <node/>
    </DFFormat>
    <Occurrence>
      <One/>
    </Occurrence>
    <DFTitle>Mapping rules between the V2X service identifier and the
destination Layer-2 ID for broadcast for V2X communication over the NR-PC5.</DFTitle>

```

```

    <DFType>
      <DDFName/>
    </DFType>
  </DFProperties>

  <Node>
    <NodeName/>
    <DFProperties>
      <AccessType>
        <Get/>
        <Replace/>
      </AccessType>
      <DFFormat>
        <node/>
      </DFFormat>
      <Occurrence>
        <OneOrMore/>
      </Occurrence>
      <DFType>
        <DDFName/>
      </DFType>
    </DFProperties>

    <Node>
      <NodeName>V2XServiceIdentifier</NodeName>
      <DFProperties>
        <AccessType>
          <Get/>
          <Replace/>
        </AccessType>
        <DFFormat>
          <int/>
        </DFFormat>
        <Occurrence>
          <One/>
        </Occurrence>
        <DFTitle>V2X service identifier used in the mapping rule.</DFTitle>
        <DFType>
          <DDFName/>
        </DFType>
      </DFProperties>
    </Node>

    <Node>
      <NodeName>BroadcastDestinationlayer2ID</NodeName>
      <DFProperties>
        <AccessType>
          <Get/>
          <Replace/>
        </AccessType>
        <DFFormat>
          <bin/>
        </DFFormat>
        <Occurrence>
          <One/>
        </Occurrence>
        <DFTitle>Destination Layer 2 ID for V2X broadcast mode communication
over NR-PC5.</DFTitle>
        <DFType>
          <DDFName/>
        </DFType>
      </DFProperties>
    </Node>
  </Node>

  <Node> <!--Default_BC_DestL2ID-->
    <NodeName>DefaultBroadcastDestinationLayer2ID</NodeName>
    <DFProperties>
      <AccessType>
        <Get/>
        <Replace/>
      </AccessType>
      <DFFormat>
        <bin/>
      </DFFormat>
      <Occurrence>
        <ZeroOrOne/>
      </Occurrence>
    </DFProperties>
  </Node>

```

```

        </Occurrence>
        <DFTitle>Default destination Layer-2 ID for V2X broadcast mode communication
over NR-PC5.</DFTitle>
        <DFType>
            <DDFName/>
        </DFType>
    </DFProperties>
</Node>

<Node> <!--V2XServiceID_to_GC_DestL2ID_MappingRule-->
    <NodeName>V2XServiceIDtoGroupcastDestinationLayer2IDMappingRule</NodeName>
    <DFProperties>
        <AccessType>
            <Get/>
            <Replace/>
        </AccessType>
        <DFFormat>
            <node/>
        </DFFormat>
        <Occurrence>
            <One/>
        </Occurrence>
        <DFTitle>Mapping rules between the V2X service identifier and the
destination Layer-2 ID for groupcast for V2X communication over the NR-PC5.</DFTitle>
        <DFType>
            <DDFName/>
        </DFType>
    </DFProperties>

    <Node>
        <NodeName/>
        <DFProperties>
            <AccessType>
                <Get/>
                <Replace/>
            </AccessType>
            <DFFormat>
                <node/>
            </DFFormat>
            <Occurrence>
                <OneOrMore/>
            </Occurrence>
            <DFType>
                <DDFName/>
            </DFType>
        </DFProperties>

    <Node>
        <NodeName>V2XServiceIdentifier</NodeName>
        <DFProperties>
            <AccessType>
                <Get/>
                <Replace/>
            </AccessType>
            <DFFormat>
                <int/>
            </DFFormat>
            <Occurrence>
                <One/>
            </Occurrence>
            <DFTitle>V2X service identifier used in the mapping rule.</DFTitle>
            <DFType>
                <DDFName/>
            </DFType>
        </DFProperties>
    </Node>

    <Node>
        <NodeName>GroupcastDestinationlayer2ID</NodeName>
        <DFProperties>
            <AccessType>
                <Get/>
                <Replace/>
            </AccessType>
            <DFFormat>
                <bin/>
            </DFFormat>
            <Occurrence>

```

```

        <One/>
      </Occurrence>
      <DFTitle>Destination Layer 2 ID for V2X groupcast mode communication
over NR-PC5.</DFTitle>
      <DFType>
        <DDFName/>
      </DFType>
    </DFProperties>
  </Node>
</Node>
</Node>
<Node> <!--V2XServiceID_to_UC_Init_Sig_DestL2ID_MappingRule-->
  <NodeName>V2XServiceIDtoUnicastInitialSignallingDestinationLayer2IDMappingRule</NodeName>
  <DFProperties>
    <AccessType>
      <Get/>
      <Replace/>
    </AccessType>
    <DFFormat>
      <node/>
    </DFFormat>
    <Occurrence>
      <One/>
    </Occurrence>
    <DFTitle>Mapping rules between the V2X service identifier and the
destination Layer-2 ID for unicast initial signaling for V2X communication over the NR-
PC5.</DFTitle>
    <DFType>
      <DDFName/>
    </DFType>
  </DFProperties>
  <Node>
    <NodeName/>
    <DFProperties>
      <AccessType>
        <Get/>
        <Replace/>
      </AccessType>
      <DFFormat>
        <node/>
      </DFFormat>
      <Occurrence>
        <OneOrMore/>
      </Occurrence>
      <DFType>
        <DDFName/>
      </DFType>
    </DFProperties>
    <Node>
      <NodeName>V2XServiceIdentifier</NodeName>
      <DFProperties>
        <AccessType>
          <Get/>
          <Replace/>
        </AccessType>
        <DFFormat>
          <int/>
        </DFFormat>
        <Occurrence>
          <One/>
        </Occurrence>
        <DFTitle>V2X service identifier used in the mapping rule.</DFTitle>
        <DFType>
          <DDFName/>
        </DFType>
      </DFProperties>
    </Node>
    <Node>
      <NodeName>UnicastInitialSignallingDestinationlayer2ID</NodeName>
      <DFProperties>
        <AccessType>
          <Get/>
          <Replace/>
        </AccessType>

```

```

        </AccessType>
        <DFFormat>
          <bin/>
        </DFFormat>
        <Occurrence>
          <One/>
        </Occurrence>
        <DFTitle>Default destination Layer 2 ID for initial signalling of
V2X unicast mode communication over NR-PC5.</DFTitle>
        <DFType>
          <DDFName/>
        </DFType>
      </DFProperties>
    </Node>
  </Node>
</Node>

<Node> <!--PC5QoSMappingRule-->
  <NodeName>V2XServiceIDtoPC5QoSParametersMappingRule</NodeName>
  <DFProperties>
    <AccessType>
      <Get/>
      <Replace/>
    </AccessType>
    <DFFormat>
      <node/>
    </DFFormat>
    <Occurrence>
      <One/>
    </Occurrence>
    <DFTitle> Mapping rules between the V2X service identifier and PC5 QoS
parameters for V2X communication over the NR-PC5.</DFTitle>
    <DFType>
      <DDFName/>
    </DFType>
  </DFProperties>

  <Node>
    <NodeName/>
    <DFProperties>
      <AccessType>
        <Get/>
        <Replace/>
      </AccessType>
      <DFFormat>
        <node/>
      </DFFormat>
      <Occurrence>
        <OneOrMore/>
      </Occurrence>
      <DFType>
        <DDFName/>
      </DFType>
    </DFProperties>

    <Node>
      <NodeName>V2XServiceIdentifier</NodeName>
      <DFProperties>
        <AccessType>
          <Get/>
          <Replace/>
        </AccessType>
        <DFFormat>
          <int/>
        </DFFormat>
        <Occurrence>
          <One/>
        </Occurrence>
        <DFTitle>V2X service identifier used in the mapping rule.</DFTitle>
        <DFType>
          <DDFName/>
        </DFType>
      </DFProperties>
    </Node>

    <Node>
      <NodeName>PQI</NodeName>
      <DFProperties>

```

```

        <AccessType>
          <Get/>
          <Replace/>
        </AccessType>
        <DFFormat>
          <int/>
        </DFFormat>
        <Occurrence>
          <One/>
        </Occurrence>
        <DFTitle>PC5 5QI value used for V2X communication over the NR-
PC5.</DFTitle>
        <DFType>
          <DDFName/>
        </DFType>
      </DFProperties>
    </Node>

    <Node>
      <NodeName>GuaranteedFlowBitRate</NodeName>
      <DFProperties>
        <AccessType>
          <Get/>
          <Replace/>
        </AccessType>
        <DFFormat>
          <bin/>
        </DFFormat>
        <Occurrence>
          <ZeroOrOne/>
        </Occurrence>
        <DFTitle>Guaranteed Flow Bit Rate value for V2X communication over
the NR-PC5.</DFTitle>
        <DFType>
          <DDFName/>
        </DFType>
      </DFProperties>
    </Node>

    <Node>
      <NodeName>MaximumFlowBitRate</NodeName>
      <DFProperties>
        <AccessType>
          <Get/>
          <Replace/>
        </AccessType>
        <DFFormat>
          <bin/>
        </DFFormat>
        <Occurrence>
          <ZeroOrOne/>
        </Occurrence>
        <DFTitle>Maximum Flow Bit Rate value for V2X communication over the
NR-PC5.</DFTitle>
        <DFType>
          <DDFName/>
        </DFType>
      </DFProperties>
    </Node>

    <Node>
      <NodeName>PerLinkAggregateMaximumBitRate</NodeName>
      <DFProperties>
        <AccessType>
          <Get/>
          <Replace/>
        </AccessType>
        <DFFormat>
          <bin/>
        </DFFormat>
        <Occurrence>
          <ZeroOrOne/>
        </Occurrence>
        <DFTitle>Per-Link Aggregate Maximum Bit Rate value for V2X unicast
mode communication over the NR-PC5.</DFTitle>
        <DFType>
          <DDFName/>
        </DFType>
      </DFProperties>
    </Node>

```

```

        </DFProperties>
    </Node>

    <Node>
        <NodeName>Range</NodeName>
        <DFProperties>
            <AccessType>
                <Get/>
                <Replace/>
            </AccessType>
            <DFFormat>
                <int/>
            </DFFormat>
            <Occurrence>
                <ZeroOrOne/>
            </Occurrence>
            <DFTitle>Range value for V2X groupcast mode communication over the
NR-PC5.</DFTitle>
            <DFType>
                <DDFName/>
            </DFType>
        </DFProperties>
    </Node>
</Node>
</Node>

<Node> <!--ASConfiguration-->
    <NodeName>ASConfiguration</NodeName>
    <DFProperties>
        <AccessType>
            <Get/>
            <Replace/>
        </AccessType>
        <DFFormat>
            <node/>
        </DFFormat>
        <Occurrence>
            <One/>
        </Occurrence>
        <DFTitle>AS configurations for V2X communication over the NR-PC5.</DFTitle>
        <DFType>
            <DDFName/>
        </DFType>
    </DFProperties>

    <Node> <!--SLRBMappingRule-->
        <NodeName>SLRBMappingRule</NodeName>
        <DFProperties>
            <AccessType>
                <Get/>
                <Replace/>
            </AccessType>
            <DFFormat>
                <node/>
            </DFFormat>
            <Occurrence>
                <One/>
            </Occurrence>
            <DFTitle>List of SLRB mapping rules between the PC5 QoS profile and SLRB
for V2X communication over the NR-PC5.</DFTitle>
            <DFType>
                <DDFName/>
            </DFType>
        </DFProperties>

    <Node> <!--<X+>-->
        <NodeName/>
        <DFProperties>
            <AccessType>
                <Get/>
                <Replace/>
            </AccessType>
            <DFFormat>
                <node/>
            </DFFormat>
            <Occurrence>
                <OneOrMore/>
            </Occurrence>

```

```

    <DFType>
      <DDFName/>
    </DFType>
  </DFProperties>

  <Node>  <!--PC5QoSProfile-->
    <NodeName>PC5QoSProfile</NodeName>
    <DFProperties>
      <AccessType>
        <Get/>
        <Replace/>
      </AccessType>
      <DFFormat>
        <node/>
      </DFFormat>
      <Occurrence>
        <One/>
      </Occurrence>
      <DFTitle>PC5 QoS profile for V2X communication over the NR-
PC5.</DFTitle>

      <DFType>
        <DDFName/>
      </DFType>
    </DFProperties>

    <Node>
      <NodeName>PQI</NodeName>
      <DFProperties>
        <AccessType>
          <Get/>
          <Replace/>
        </AccessType>
        <DFFormat>
          <int/>
        </DFFormat>
        <Occurrence>
          <One/>
        </Occurrence>
        <DFTitle>PC5 5QI value used for V2X communication over the
NR-PC5.</DFTitle>

        <DFType>
          <DDFName/>
        </DFType>
      </DFProperties>
    </Node>

    <Node>
      <NodeName>GuaranteedFlowBitRate</NodeName>
      <DFProperties>
        <AccessType>
          <Get/>
          <Replace/>
        </AccessType>
        <DFFormat>
          <bin/>
        </DFFormat>
        <Occurrence>
          <ZeroOrOne/>
        </Occurrence>
        <DFTitle>Guaranteed Flow Bit Rate value for V2X
communication over the NR-PC5.</DFTitle>

        <DFType>
          <DDFName/>
        </DFType>
      </DFProperties>
    </Node>

    <Node>
      <NodeName>MaximumFlowBitRate</NodeName>
      <DFProperties>
        <AccessType>
          <Get/>
          <Replace/>
        </AccessType>
        <DFFormat>
          <bin/>
        </DFFormat>
        <Occurrence>

```



```

        <ZeroOrOne/>
    </Occurrence>
    <DFTitle>Maximum Flow Bit Rate value for V2X communication
over the NR-PC5.</DFTitle>
    <DFType>
        <DDFName/>
    </DFType>
</DFProperties>
</Node>

<Node>
    <NodeName>PerLinkAggregateMaximumBitRate</NodeName>
    <DFProperties>
        <AccessType>
            <Get/>
            <Replace/>
        </AccessType>
        <DFFormat>
            <bin/>
        </DFFormat>
        <Occurrence>
            <ZeroOrOne/>
        </Occurrence>
        <DFTitle>Per-Link Aggregate Maximum Bit Rate value for V2X
unicast mode communication over the NR-PC5.</DFTitle>
        <DFType>
            <DDFName/>
        </DFType>
    </DFProperties>
</Node>

<Node>
    <NodeName>Range</NodeName>
    <DFProperties>
        <AccessType>
            <Get/>
            <Replace/>
        </AccessType>
        <DFFormat>
            <int/>
        </DFFormat>
        <Occurrence>
            <ZeroOrOne/>
        </Occurrence>
        <DFTitle>Range value for V2X groupcast mode communication
over the NR-PC5.</DFTitle>
        <DFType>
            <DDFName/>
        </DFType>
    </DFProperties>
</Node>

<Node>
    <NodeName>PriorityLevel</NodeName>
    <DFProperties>
        <AccessType>
            <Get/>
            <Replace/>
        </AccessType>
        <DFFormat>
            <int/>
        </DFFormat>
        <Occurrence>
            <ZeroOrOne/>
        </Occurrence>
        <DFTitle>ProSe per-packet priority value for V2X
communication over the NR-PC5.</DFTitle>
        <DFType>
            <DDFName/>
        </DFType>
    </DFProperties>
</Node>

<Node>
    <NodeName>AveragingWindow</NodeName>
    <DFProperties>
        <AccessType>
            <Get/>

```

```

        <Replace/>
      </AccessType>
    <DFFormat>
      <int/>
    </DFFormat>
    <Occurrence>
      <ZeroOrOne/>
    </Occurrence>
    <DFTitle>Averaging window for both sending and receiving for
V2X communication over the NR-PC5.</DFTitle>
    <DFType>
      <DDFName/>
    </DFType>
  </DFProperties>
</Node>

<Node>
  <NodeName>MaximumDataBurstVolume</NodeName>
  <DFProperties>
    <AccessType>
      <Get/>
      <Replace/>
    </AccessType>
    <DFFormat>
      <int/>
    </DFFormat>
    <Occurrence>
      <ZeroOrOne/>
    </Occurrence>
    <DFTitle>Maximum data burst volume value for both sending
and receiving for V2X communication over the NR-PC5.</DFTitle>
    <DFType>
      <DDFName/>
    </DFType>
  </DFProperties>
</Node>

</Node> <!--PC5QoSProfile ends-->

<Node>
  <NodeName>SLRB</NodeName>
  <DFProperties>
    <AccessType>
      <Get/>
      <Replace/>
    </AccessType>
    <DFFormat>
      <bin/>
    </DFFormat>
    <Occurrence>
      <One/>
    </Occurrence>
    <DFTitle>SLRB value for V2X communication over the NR-
PC5.</DFTitle>
    <DFType>
      <DDFName/>
    </DFType>
  </DFProperties>
</Node>

</Node>
</Node>
</Node> <!--ASConfiguration ends-->

<Node> <!--DefaultModeOfCommunicationMappingRule-->
  <NodeName>V2XServiceIDtoDefaultModeOfCommunicationMappingRule</NodeName>
  <DFProperties>
    <AccessType>
      <Get/>
      <Replace/>
    </AccessType>
    <DFFormat>
      <node/>
    </DFFormat>
    <Occurrence>
      <One/>
    </Occurrence>

```

```

    <DFTitle>Mapping rules between the V2X service identifier and the default
mode of communication for V2X communication over the NR-PC5.</DFTitle>
    <DFType>
      <DDFName/>
    </DFType>
  </DFProperties>

  <Node> <!--X+-->
    <NodeName/>
    <DFProperties>
      <AccessType>
        <Get/>
        <Replace/>
      </AccessType>
      <DFFormat>
        <node/>
      </DFFormat>
      <Occurrence>
        <OneOrMore/>
      </Occurrence>
      <DFType>
        <DDFName/>
      </DFType>
    </DFProperties>

  <Node>
    <NodeName>V2XServiceIdentifier</NodeName>
    <DFProperties>
      <AccessType>
        <Get/>
        <Replace/>
      </AccessType>
      <DFFormat>
        <int/>
      </DFFormat>
      <Occurrence>
        <One/>
      </Occurrence>
      <DFTitle>V2X service identifier used in the mapping rule.</DFTitle>
      <DFType>
        <DDFName/>
      </DFType>
    </DFProperties>
  </Node>

  <Node>
    <NodeName>DefaultModeOfCommunication</NodeName>
    <DFProperties>
      <AccessType>
        <Get/>
        <Replace/>
      </AccessType>
      <DFFormat>
        <bin/>
      </DFFormat>
      <Occurrence>
        <One/>
      </Occurrence>
      <DFTitle>Default mode of communication for V2X communication over
the NR-PC5.</DFTitle>
      <DFType>
        <DDFName/>
      </DFType>
    </DFProperties>
  </Node>
</Node>

  <Node> <!--NRPC5UnicastSecurityPolicies-->
    <NodeName>NRPC5UnicastSecurityPolicies</NodeName>
    <DFProperties>
      <AccessType>
        <Get/>
        <Replace/>
      </AccessType>
      <DFFormat>
        <node/>
      </DFFormat>

```

```

    <Occurrence>
      <One/>
    </Occurrence>
    <DFTitle>Security policies for V2X unicast mode communication over the NR-
PC5.</DFTitle>
    <DFType>
      <DDFName/>
    </DFType>
  </DFProperties>
</Node> <!--X+-->
  <NodeName/>
  <DFProperties>
    <AccessType>
      <Get/>
      <Replace/>
    </AccessType>
    <DFFormat>
      <node/>
    </DFFormat>
    <Occurrence>
      <OneOrMore/>
    </Occurrence>
    <DFType>
      <DDFName/>
    </DFType>
  </DFProperties>

  <Node>
    <NodeName>V2XServiceIdentifier</NodeName>
    <DFProperties>
      <AccessType>
        <Get/>
        <Replace/>
      </AccessType>
      <DFFormat>
        <int/>
      </DFFormat>
      <Occurrence>
        <One/>
      </Occurrence>
      <DFTitle>V2X service identifier used in the mapping rule.</DFTitle>
      <DFType>
        <DDFName/>
      </DFType>
    </DFProperties>
  </Node>

  <Node>
    <NodeName>SecurityPolicies</NodeName>
    <DFProperties>
      <AccessType>
        <Get/>
        <Replace/>
      </AccessType>
      <DFFormat>
        <node/>
      </DFFormat>
      <Occurrence>
        <One/>
      </Occurrence>
      <DFTitle>Security policies for V2X communication over the NR-
PC5.</DFTitle>
      <DFType>
        <DDFName/>
      </DFType>
    </DFProperties>

    <Node>
      <NodeName>SignallingIntegrityProtectionPolicy</NodeName>
      <DFProperties>
        <AccessType>
          <Get/>
          <Replace/>
        </AccessType>
        <DFFormat>
          <bin/>
        </DFFormat>

```

```

        <Occurrence>
        <One/>
    </Occurrence>
    <DFTitle>Signalling integrity protection policy for V2X
communication over the NR-PC5.</DFTitle>
    <DFType>
    <DDFName/>
    </DFType>
</DFProperties>
</Node>

<Node>
    <NodeName>SignallingCipherringPolicy</NodeName>
    <DFProperties>
    <AccessType>
    <Get/>
    <Replace/>
    </AccessType>
    <DFFormat>
    <bin/>
    </DFFormat>
    <Occurrence>
    <One/>
    </Occurrence>
    <DFTitle>Signalling cipherring policy for V2X communication over
the NR-PC5.</DFTitle>
    <DFType>
    <DDFName/>
    </DFType>
    </DFProperties>
</Node>

<Node>
    <NodeName>UserPlaneIntegrityProtectionPolicy</NodeName>
    <DFProperties>
    <AccessType>
    <Get/>
    <Replace/>
    </AccessType>
    <DFFormat>
    <bin/>
    </DFFormat>
    <Occurrence>
    <One/>
    </Occurrence>
    <DFTitle>User plane integrity protection policy for V2X
communication over the NR-PC5.</DFTitle>
    <DFType>
    <DDFName/>
    </DFType>
    </DFProperties>
</Node>

<Node>
    <NodeName>UserPlaneCipherringPolicy</NodeName>
    <DFProperties>
    <AccessType>
    <Get/>
    <Replace/>
    </AccessType>
    <DFFormat>
    <bin/>
    </DFFormat>
    <Occurrence>
    <One/>
    </Occurrence>
    <DFTitle>User plane cipherring policy for V2X communication over
the NR-PC5.</DFTitle>
    <DFType>
    <DDFName/>
    </DFType>
    </DFProperties>
</Node>
</Node>

<Node>
    <NodeName>GeographicalArea</NodeName>
    <DFProperties>

```

```

    <AccessType>
      <Get/>
      <Replace/>
    </AccessType>
  </DFFormat>
  </DFFormat>
  <Occurrence>
    <One/>
  </Occurrence>
  <DFTitle>Geographical Area description.</DFTitle>
  <DFType>
    <MIME>text/plain</MIME>
  </DFType>
</DFProperties>

<Node>
  <NodeName>Polygon</NodeName>
  <DFProperties>
    <AccessType>
      <Get/>
      <Replace/>
    </AccessType>
    <DFFormat>
      <node/>
    </DFFormat>
    <Occurrence>
      <One/>
    </Occurrence>
    <DFTitle>Polygon Area description.</DFTitle>
    <DFType>
      <DDFName/>
    </DFType>
  </DFProperties>

<Node>
  <NodeName/>
  <DFProperties>
    <AccessType>
      <Get/>
      <Replace/>
    </AccessType>
    <DFFormat>
      <node/>
    </DFFormat>
    <Occurrence>
      <OneOrMore/>
    </Occurrence>
    <DFType>
      <DDFName/>
    </DFType>
  </DFProperties>

  <Node>
    <NodeName>Coordinates</NodeName>
    <DFProperties>
      <AccessType>
        <Get/>
        <Replace/>
      </AccessType>
      <DFFormat>
        <node/>
      </DFFormat>
      <Occurrence>
        <One/>
      </Occurrence>
      <DFTitle>Descriptions for geographical
coordinates</DFTitle>
      <DFType>
        <MIME>text/plain</MIME>
      </DFType>
    </DFProperties>

  <Node>
    <NodeName/>
    <DFProperties>
      <AccessType>
        <Get/>

```

```
<Replace/>
</AccessType>
<DFFormat>
  <node/>
</DFFormat>
<Occurrence>
  <OneOrMore/>
</Occurrence>
<DFType>
  <DDFName/>
</DFType>
</DFProperties>

<Node>
  <nodeName>Latitude</nodeName>
  <DFProperties>
    <AccessType>
      <Get/>
      <Replace/>
    </AccessType>
    <DFFormat>
      <bin/>
    </DFFormat>
    <Occurrence>
      <One/>
    </Occurrence>
    <DFTitle>Coordinate Latitude</DFTitle>
    <DFType>
      <MIME>text/plain</MIME>
    </DFType>
  </DFProperties>
</Node>

<Node>
  <nodeName>Longitude</nodeName>
  <DFProperties>
    <AccessType>
      <Get/>
      <Replace/>
    </AccessType>
    <DFFormat>
      <bin/>
    </DFFormat>
    <Occurrence>
      <One/>
    </Occurrence>
    <DFTitle>Coordinate Longitude</DFTitle>
    <DFType>
      <MIME>text/plain</MIME>
    </DFType>
  </DFProperties>
</Node>
</Node>
</Node>
</Node>
</Node>
</Node>
</Node>
</Node>
</Node>
</Node>

<!-- The V2XoverNRPC5 node ends here. -->
</Node>

</Node>

<Node>
  <nodeName>V2XoverLTEUu</nodeName>
  <!-- The V2XProvisioning node starts here. -->
  <DFProperties>
    <AccessType>
      <Get/>
      <Replace/>
    </AccessType>
    <DFFormat>
      <node/>
    </DFFormat>
    <Occurrence>
      <One/>
    </Occurrence>
```

```

    </Occurrence>
    <DFTitle>Configuration parameters for V2X communication over LTE-Uu.</DFTitle>
    <DFType>
      <DDFName/>
    </DFType>
  </DFProperties>

  <Node>
    <NodeName>Expiration</NodeName>
    <DFProperties>
      <AccessType>
        <Get/>
        <Replace/>
      </AccessType>
      <DFFormat>
        <int/>
      </DFFormat>
      <Occurrence>
        <One/>
      </Occurrence>
      <DFTitle>Expiration time of validity.</DFTitle>
      <DFType>
        <DDFName/>
      </DFType>
    </DFProperties>
  </Node>

  <Node>
    <NodeName>ToConRefs</NodeName>
    <DFProperties>
      <AccessType>
        <Get/>
        <Replace/>
      </AccessType>
      <DFFormat>
        <node/>
      </DFFormat>
      <Occurrence>
        <ZeroOrOne/>
      </Occurrence>
      <DFTitle>collection of connectivity definitions.</DFTitle>
      <DFType>
        <DDFName/>
      </DFType>
    </DFProperties>

    <Node>
      <NodeName/>
      <DFProperties>
        <AccessType>
          <Get/>
          <Replace/>
        </AccessType>
        <DFFormat>
          <node/>
        </DFFormat>
        <Occurrence>
          <OneOrMore/>
        </Occurrence>
        <DFTitle>The name node for one or more connectivity parameters.</DFTitle>
        <DFType>
          <DDFName/>
        </DFType>
      </DFProperties>

      <Node>
        <NodeName>ConRef</NodeName>
        <DFProperties>
          <AccessType>
            <Get/>
            <Replace/>
          </AccessType>
          <DFFormat>
            <chr/>
          </DFFormat>
          <Occurrence>
            <One/>
          </Occurrence>
        </DFProperties>
      </Node>
    </Node>
  </Node>

```



```

        <DFTitle> Linkage to connectivity parameters.</DFTitle>
        <DFType>
            <MIME>text/plain</MIME>
        </DFType>
    </DFProperties>
</Node>
</Node>
</Node>
<Node>
    <NodeName>AuthorizedPLMNs</NodeName>
    <DFProperties>
        <AccessType>
            <Get/>
            <Replace/>
        </AccessType>
        <DFFormat>
            <node/>
        </DFFormat>
        <Occurrence>
            <One/>
        </Occurrence>
        <DFTitle>Authorization per PLMN policies for V2X communication over LTE-
Uu.</DFTitle>
    <DFType>
        <DDFName/>
    </DFType>
    </DFProperties>
</Node>
<Node>
    <NodeName></NodeName>
    <DFProperties>
        <AccessType>
            <Get/>
            <Replace/>
        </AccessType>
        <DFFormat>
            <node/>
        </DFFormat>
        <Occurrence>
            <ZeroOrMore/>
        </Occurrence>
        <DFType>
            <DDFName></DDFName>
        </DFType>
    </DFProperties>
</Node>
<Node>
    <NodeName>PLMN</NodeName>
    <DFProperties>
        <AccessType>
            <Get/>
            <Replace/>
        </AccessType>
        <DFFormat>
            <chr/>
        </DFFormat>
        <Occurrence>
            <One/>
        </Occurrence>
        <DFTitle>PLMN code.</DFTitle>
        <DFType>
            <MIME>text/plain</MIME>
        </DFType>
    </DFProperties>
</Node>
<Node>
    <NodeName>V2XASMBMSConfig</NodeName>
    <DFProperties>
        <AccessType>
            <Get/>
            <Replace/>
        </AccessType>
        <DFFormat>
            <node/>
        </DFFormat>
        <Occurrence>

```

```

        <ZeroOrOne/>
    </Occurrence>
    <DFTitle>MBMS configuration.</DFTitle>
    <DFType>
        <DDFName/>
    </DFType>
</DFProperties>

<Node>
    <NodeName>TMGI</NodeName>
    <DFProperties>
        <AccessType>
            <Get/>
            <Replace/>
        </AccessType>
        <DFFormat>
            <chr/>
        </DFFormat>
        <Occurrence>
            <One/>
        </Occurrence>
        <DFTitle>TMGI value.</DFTitle>
        <DFType>
            <MIME>text/plain</MIME>
        </DFType>
    </DFProperties>
</Node>

<Node>
    <NodeName>SAIList</NodeName>
    <DFProperties>
        <AccessType>
            <Get/>
            <Replace/>
        </AccessType>
        <DFFormat>
            <node/>
        </DFFormat>
        <Occurrence>
            <One/>
        </Occurrence>
        <DFTitle>Service Area Identifiers.</DFTitle>
        <DFType>
            <MIME>text/plain</MIME>
        </DFType>
    </DFProperties>

<Node>
    <NodeName></NodeName>
    <DFProperties>
        <AccessType>
            <Get/>
            <Replace/>
        </AccessType>
        <DFFormat>
            <node/>
        </DFFormat>
        <Occurrence>
            <OneOrMore/>
        </Occurrence>
        <DFType>
            <DDFName></DDFName>
        </DFType>
    </DFProperties>

<Node>
    <NodeName>SAI</NodeName>
    <DFProperties>
        <AccessType>
            <Get/>
            <Replace/>
        </AccessType>
        <DFFormat>
            <chr/>
        </DFFormat>
        <Occurrence>
            <One/>
        </Occurrence>

```

```

        <DFTitle>SAI.</DFTitle>
        <DFType>
            <MIME>text/plain</MIME>
        </DFType>
    </DFProperties>
</Node>
</Node>
</Node>
<Node>
    <NodeName>Frequency</NodeName>
    <DFProperties>
        <AccessType>
            <Get/>
            <Replace/>
        </AccessType>
        <DFFormat>
            <chr/>
        </DFFormat>
        <Occurrence>
            <ZeroOrOne/>
        </Occurrence>
        <DFTitle>EARFCN defined by 3GPP RAN WG.</DFTitle>
        <DFType>
            <MIME>text/plain</MIME>
        </DFType>
    </DFProperties>
</Node>
</Node>
<Node>
    <NodeName>SDPInV2XASMBMSConfig</NodeName>
    <DFProperties>
        <AccessType>
            <Get/>
            <Replace/>
        </AccessType>
        <DFFormat>
            <chr/>
        </DFFormat>
        <Occurrence>
            <One/>
        </Occurrence>
        <DFTitle>V2X MBMS configuration SDP.</DFTitle>
        <DFType>
            <MIME>text/plain</MIME>
        </DFType>
    </DFProperties>
</Node>
</Node>
<Node>
    <NodeName>V2XServiceIdentifierUnrelated</NodeName>
    <DFProperties>
        <AccessType>
            <Get/>
            <Replace/>
        </AccessType>
        <DFFormat>
            <node/>
        </DFFormat>
        <Occurrence>
            <One/>
        </Occurrence>
        <DFTitle>V2X services not identified by a V2X service
identifier.</DFTitle>
        <DFType>
            <DDFName/>
        </DFType>
    </DFProperties>
</Node>
<Node>
    <NodeName>V2XMBMSConfigs</NodeName>
    <DFProperties>
        <AccessType>
            <Get/>
            <Replace/>
        </AccessType>
        <DFFormat>

```

```

        <node/>
    </DFFormat>
    <Occurrence>
        <ZeroOrOne/>
    </Occurrence>
    <DFTitle>MBMS configurations.</DFTitle>
    <DFType>
        <DDFName/>
    </DFType>
</DFProperties>

<Node>
    <NodeName/>
    <DFProperties>
        <AccessType>
            <Get/>
            <Replace/>
        </AccessType>
        <DFFormat>
            <node/>
        </DFFormat>
        <Occurrence>
            <OneOrMore/>
        </Occurrence>
        <DFTitle>MBMS configurations.</DFTitle>
        <DFType>
            <DDFName/>
        </DFType>
    </DFProperties>

<Node>
    <NodeName>V2XMBMSConfig</NodeName>
    <DFProperties>
        <AccessType>
            <Get/>
            <Replace/>
        </AccessType>
        <DFFormat>
            <node/>
        </DFFormat>
        <Occurrence>
            <ZeroOrOne/>
        </Occurrence>
        <DFTitle>MBMS configuration.</DFTitle>
        <DFType>
            <DDFName/>
        </DFType>
    </DFProperties>

<Node>
    <NodeName>TMGI</NodeName>
    <DFProperties>
        <AccessType>
            <Get/>
            <Replace/>
        </AccessType>
        <DFFormat>
            <chr/>
        </DFFormat>
        <Occurrence>
            <One/>
        </Occurrence>
        <DFTitle>TMGI value.</DFTitle>
        <DFType>
            <MIME>text/plain</MIME>
        </DFType>
    </DFProperties>
</Node>

<Node>
    <NodeName>SAIList</NodeName>
    <DFProperties>
        <AccessType>
            <Get/>
            <Replace/>
        </AccessType>
        <DFFormat>
            <node/>

```

```

    </DFFormat>
    <Occurrence>
      <One/>
    </Occurrence>
    <DFTitle>Service Area Identifiers.</DFTitle>
    <DFType>
      <MIME>text/plain</MIME>
    </DFType>
  </DFProperties>
</Node>
<Node>
  <NodeName></NodeName>
  <DFProperties>
    <AccessType>
      <Get/>
      <Replace/>
    </AccessType>
    <DFFormat>
      <node/>
    </DFFormat>
    <Occurrence>
      <OneOrMore/>
    </Occurrence>
    <DFType>
      <DDFName></DDFName>
    </DFType>
  </DFProperties>
</Node>
<Node>
  <NodeName>SAI</NodeName>
  <DFProperties>
    <AccessType>
      <Get/>
      <Replace/>
    </AccessType>
    <DFFormat>
      <chr/>
    </DFFormat>
    <Occurrence>
      <One/>
    </Occurrence>
    <DFTitle>SAI.</DFTitle>
    <DFType>
      <MIME>text/plain</MIME>
    </DFType>
  </DFProperties>
</Node>
</Node>
<Node>
  <NodeName>Frequency</NodeName>
  <DFProperties>
    <AccessType>
      <Get/>
      <Replace/>
    </AccessType>
    <DFFormat>
      <chr/>
    </DFFormat>
    <Occurrence>
      <ZeroOrOne/>
    </Occurrence>
    <DFTitle>EARFCN defined by 3GPP RAN WG.</DFTitle>
    <DFType>
      <MIME>text/plain</MIME>
    </DFType>
  </DFProperties>
</Node>
<Node>
  <NodeName>SDPInV2XASMBMSConfig</NodeName>
  <DFProperties>
    <AccessType>
      <Get/>
      <Replace/>
    </AccessType>
    <DFFormat>

```

```

        <chr/>
      </DFFormat>
    </Occurrence>
    <One/>
  </Occurrence>
  <DFTitle>V2X MBMS configuration SDP.</DFTitle>
  <DFType>
    <MIME>text/plain</MIME>
  </DFType>
</DFProperties>
</Node>
</Node>

</Node>
</Node>

<Node>
  <NodeName>V2XASAddresses</NodeName>
  <DFProperties>
    <AccessType>
      <Get/>
      <Replace/>
    </AccessType>
    <DFFormat>
      <node/>
    </DFFormat>
    <Occurrence>
      <ZeroOrOne/>
    </Occurrence>
    <DFTitle>V2X server addresses.</DFTitle>
    <DFType>
      <DDFName/>
    </DFType>
  </DFProperties>

  <Node>
    <NodeName></NodeName>
    <DFProperties>
      <AccessType>
        <Get/>
        <Replace/>
      </AccessType>
      <DFFormat>
        <node/>
      </DFFormat>
      <Occurrence>
        <OneOrMore/>
      </Occurrence>
      <DFType>
        <DDFName></DDFName>
      </DFType>
    </DFProperties>

    <Node>
      <NodeName>L3Address</NodeName>
      <DFProperties>
        <AccessType>
          <Get/>
          <Replace/>
        </AccessType>
        <DFFormat>
          <chr/>
        </DFFormat>
        <Occurrence>
          <One/>
        </Occurrence>
        <DFTitle>IP address or FQDN of the V2X application
server.</DFTitle>
        <DFType>
          <DDFName/>
        </DFType>
      </DFProperties>
    </Node>

    <Node>
      <NodeName>UDPPort</NodeName>
      <DFProperties>
        <AccessType>

```

```

        <Get />
        <Replace />
    </AccessType>
    <DFFormat>
        <int />
    </DFFormat>
    <Occurrence>
        <One />
    </Occurrence>
    <DFTitle>UDP port of the V2X application server.</DFTitle>
    <DFType>
        <DDFName />
    </DFType>
</DFProperties>
</Node>

<Node>
    <NodeName>GeographicalArea</NodeName>
    <DFProperties>
        <AccessType>
            <Get />
            <Replace />
        </AccessType>
        <DFFormat>
            <node />
        </DFFormat>
        <Occurrence>
            <ZeroOrOne />
        </Occurrence>
        <DFTitle>Geographical Area description.</DFTitle>
        <DFType>
            <MIME>text/plain</MIME>
        </DFType>
    </DFProperties>

    <Node>
        <NodeName>Polygon</NodeName>
        <DFProperties>
            <AccessType>
                <Get />
                <Replace />
            </AccessType>
            <DFFormat>
                <node />
            </DFFormat>
            <Occurrence>
                <One />
            </Occurrence>
            <DFTitle>Polygon Area description.</DFTitle>
            <DFType>
                <DDFName />
            </DFType>
        </DFProperties>

        <Node>
            <NodeName></NodeName>
            <DFProperties>
                <AccessType>
                    <Get />
                    <Replace />
                </AccessType>
                <DFFormat>
                    <node />
                </DFFormat>
                <Occurrence>
                    <OneOrMore />
                </Occurrence>
                <DFType>
                    <DDFName></DDFName>
                </DFType>
            </DFProperties>

            <Node>
                <NodeName>Coordinates</NodeName>
                <DFProperties>
                    <AccessType>
                        <Get />
                        <Replace />
                    </AccessType>

```

coordinates</DFTitle>

```

    </AccessType>
    <DFFormat>
      <node/>
    </DFFormat>
    <Occurrence>
      <One/>
    </Occurrence>
    <DFTitle>Descriptions for geographical
coordinates</DFTitle>

    <DFType>
      <MIME>text/plain</MIME>
    </DFType>
  </DFProperties>

  <Node>
    <NodeName></NodeName>
    <DFProperties>
      <AccessType>
        <Get/>
        <Replace/>
      </AccessType>
      <DFFormat>
        <node/>
      </DFFormat>
      <Occurrence>
        <OneOrMore/>
      </Occurrence>
      <DFType>
        <DDFName></DDFName>
      </DFType>
    </DFProperties>

    <Node>
      <NodeName>Latitude</NodeName>
      <DFProperties>
        <AccessType>
          <Get/>
          <Replace/>
        </AccessType>
        <DFFormat>
          <bin/>
        </DFFormat>
        <Occurrence>
          <One/>
        </Occurrence>
        <DFTitle>coordinate latitude</DFTitle>
        <DFType>
          <MIME>text/plain</MIME>
        </DFType>
      </DFProperties>
    </Node>

    <Node>
      <NodeName>Longitude</NodeName>
      <DFProperties>
        <AccessType>
          <Get/>
          <Replace/>
        </AccessType>
        <DFFormat>
          <bin/>
        </DFFormat>
        <Occurrence>
          <One/>
        </Occurrence>
        <DFTitle>coordinate longitude</DFTitle>
        <DFType>
          <MIME>text/plain</MIME>
        </DFType>
      </DFProperties>
    </Node>
  </Node>
</Node>
</Node>
</Node>
</Node>
</Node>
</Node>
</Node>
</Node>

```



```

</Node>
<Node>
  <NodeName>V2XServiceIdentifierRelated</NodeName>
  <DFProperties>
    <AccessType>
      <Get/>
      <Replace/>
    </AccessType>
    <DFFormat>
      <node/>
    </DFFormat>
    <Occurrence>
      <One/>
    </Occurrence>
    <DFTitle>V2X services identified by a V2X service identifier.</DFTitle>
    <DFType>
      <DDFName/>
    </DFType>
  </DFProperties>

  <Node>
    <NodeName>AuthorizedV2XServiceList</NodeName>
    <DFProperties>
      <AccessType>
        <Get/>
        <Replace/>
      </AccessType>
      <DFFormat>
        <node/>
      </DFFormat>
      <Occurrence>
        <One/>
      </Occurrence>
      <DFTitle>Authorized V2X services for V2X communication over LTE-
Uu.</DFTitle>
      <DFType>
        <DDFName/>
      </DFType>
    </DFProperties>

    <Node>
      <NodeName></NodeName>
      <DFProperties>
        <AccessType>
          <Get/>
          <Replace/>
        </AccessType>
        <DFFormat>
          <node/>
        </DFFormat>
        <Occurrence>
          <ZeroOrMore/>
        </Occurrence>
        <DFType>
          <DDFName></DDFName>
        </DFType>
      </DFProperties>

    <Node>
      <NodeName>V2XServiceIdentifier</NodeName>
      <DFProperties>
        <AccessType>
          <Get/>
          <Replace/>
        </AccessType>
        <DFFormat>
          <int/>
        </DFFormat>
        <Occurrence>
          <One/>
        </Occurrence>
        <DFTitle>V2X service identifier.</DFTitle>
        <DFType>
          <DDFName></DDFName>
        </DFType>
      </DFProperties>
    </Node>
  </Node>

```

```

<Node>
  <NodeName>V2XMBMSConfigs</NodeName>
  <DFProperties>
    <AccessType>
      <Get/>
      <Replace/>
    </AccessType>
    <DFFormat>
      <node/>
    </DFFormat>
    <Occurrence>
      <ZeroOrOne/>
    </Occurrence>
    <DFTitle>MBMS configurations.</DFTitle>
    <DFType>
      <DDFName/>
    </DFType>
  </DFProperties>

  <Node>
    <NodeName/>
    <DFProperties>
      <AccessType>
        <Get/>
        <Replace/>
      </AccessType>
      <DFFormat>
        <node/>
      </DFFormat>
      <Occurrence>
        <OneOrMore/>
      </Occurrence>
      <DFTitle>MBMS configurations.</DFTitle>
      <DFType>
        <DDFName/>
      </DFType>
    </DFProperties>

  <Node>
    <NodeName>V2XMBMSConfig</NodeName>
    <DFProperties>
      <AccessType>
        <Get/>
        <Replace/>
      </AccessType>
      <DFFormat>
        <node/>
      </DFFormat>
      <Occurrence>
        <ZeroOrOne/>
      </Occurrence>
      <DFTitle>MBMS configuration.</DFTitle>
      <DFType>
        <DDFName/>
      </DFType>
    </DFProperties>

  <Node>
    <NodeName>TMGI</NodeName>
    <DFProperties>
      <AccessType>
        <Get/>
        <Replace/>
      </AccessType>
      <DFFormat>
        <chr/>
      </DFFormat>
      <Occurrence>
        <One/>
      </Occurrence>
      <DFTitle>TMGI value.</DFTitle>
      <DFType>
        <MIME>text/plain</MIME>
      </DFType>
    </DFProperties>
  </Node>

```

```

<Node>
  <NodeName>SAIList</NodeName>
  <DFProperties>
    <AccessType>
      <Get/>
      <Replace/>
    </AccessType>
    <DFFormat>
      <node/>
    </DFFormat>
    <Occurrence>
      <One/>
    </Occurrence>
    <DFTitle>Service Area Identifiers.</DFTitle>
    <DFType>
      <MIME>text/plain</MIME>
    </DFType>
  </DFProperties>

  <Node>
    <NodeName></NodeName>
    <DFProperties>
      <AccessType>
        <Get/>
        <Replace/>
      </AccessType>
      <DFFormat>
        <node/>
      </DFFormat>
      <Occurrence>
        <OneOrMore/>
      </Occurrence>
      <DFType>
        <DDFName></DDFName>
      </DFType>
    </DFProperties>

    <Node>
      <NodeName>SAI</NodeName>
      <DFProperties>
        <AccessType>
          <Get/>
          <Replace/>
        </AccessType>
        <DFFormat>
          <chr/>
        </DFFormat>
        <Occurrence>
          <One/>
        </Occurrence>
        <DFTitle>SAI.</DFTitle>
        <DFType>
          <MIME>text/plain</MIME>
        </DFType>
      </DFProperties>
    </Node>
  </Node>
</Node>

  <Node>
    <NodeName>Frequency</NodeName>
    <DFProperties>
      <AccessType>
        <Get/>
        <Replace/>
      </AccessType>
      <DFFormat>
        <chr/>
      </DFFormat>
      <Occurrence>
        <ZeroOrOne/>
      </Occurrence>
      <DFTitle>EARFCN defined by 3GPP RAN
      <DFTitle>WG.</DFTitle>
      <DFType>
        <MIME>text/plain</MIME>
      </DFType>
    </DFProperties>
  </Node>

```

```

</Node>
<Node>
  <NodeName>SDPInV2XASMBMSConfig</NodeName>
  <DFProperties>
    <AccessType>
      <Get/>
      <Replace/>
    </AccessType>
    <DFFormat>
      <chr/>
    </DFFormat>
    <Occurrence>
      <One/>
    </Occurrence>
    <DFTitle>V2X MBMS configuration
SDP.</DFTitle>
  <DFType>
    <MIME>text/plain</MIME>
  </DFType>
  </DFProperties>
</Node>
</Node>
</Node>
<Node>
  <NodeName>V2XASAddresses</NodeName>
  <DFProperties>
    <AccessType>
      <Get/>
      <Replace/>
    </AccessType>
    <DFFormat>
      <node/>
    </DFFormat>
    <Occurrence>
      <ZeroOrOne/>
    </Occurrence>
    <DFTitle>V2X server addresses.</DFTitle>
    <DFType>
      <DDFName/>
    </DFType>
  </DFProperties>
  <Node>
    <NodeName></NodeName>
    <DFProperties>
      <AccessType>
        <Get/>
        <Replace/>
      </AccessType>
      <DFFormat>
        <node/>
      </DFFormat>
      <Occurrence>
        <OneOrMore/>
      </Occurrence>
      <DFType>
        <DDFName></DDFName>
      </DFType>
    </DFProperties>
  <Node>
    <NodeName>L3Address</NodeName>
    <DFProperties>
      <AccessType>
        <Get/>
        <Replace/>
      </AccessType>
      <DFFormat>
        <chr/>
      </DFFormat>
      <Occurrence>
        <One/>
      </Occurrence>
    </DFProperties>
  </Node>
</Node>

```

```

server.</DFTitle>
    <DFTitle>IP address or FQDN of the V2X application
    <DFType>
        <DDFName/>
    </DFType>
    </DFProperties>
</Node>

<Node>
    <NodeName>UDPPort</NodeName>
    <DFProperties>
        <AccessType>
            <Get/>
            <Replace/>
        </AccessType>
        <DFFormat>
            <int/>
        </DFFormat>
        <Occurrence>
            <One/>
        </Occurrence>
        <DFTitle>UDP port of the V2X application
        <DFType>
            <DDFName/>
        </DFType>
    </DFProperties>
</Node>

<Node>
    <NodeName>GeographicalArea</NodeName>
    <DFProperties>
        <AccessType>
            <Get/>
            <Replace/>
        </AccessType>
        <DFFormat>
            <node/>
        </DFFormat>
        <Occurrence>
            <ZeroOrOne/>
        </Occurrence>
        <DFTitle>Geographical Area description.</DFTitle>
        <DFType>
            <MIME>text/plain</MIME>
        </DFType>
    </DFProperties>

    <Node>
        <NodeName>Polygon</NodeName>
        <DFProperties>
            <AccessType>
                <Get/>
                <Replace/>
            </AccessType>
            <DFFormat>
                <node/>
            </DFFormat>
            <Occurrence>
                <One/>
            </Occurrence>
            <DFTitle>Polygon Area description.</DFTitle>
            <DFType>
                <DDFName/>
            </DFType>
        </DFProperties>

    <Node>
        <NodeName></NodeName>
        <DFProperties>
            <AccessType>
                <Get/>
                <Replace/>
            </AccessType>
            <DFFormat>
                <node/>
            </DFFormat>
            <Occurrence>

```

```

        <OneOrMore/>
    </Occurrence>
    <DFType>
        <DDFName></DDFName>
    </DFType>
</DFProperties>

<Node>
    <NodeName>Coordinates</NodeName>
    <DFProperties>
        <AccessType>
            <Get/>
            <Replace/>
        </AccessType>
        <DFFormat>
            <node/>
        </DFFormat>
        <Occurrence>
            <One/>
        </Occurrence>
        <DFTitle>Descriptions for geographical

coordinates</DFTitle>

    <DFType>
        <MIME>text/plain</MIME>
    </DFType>
</DFProperties>

<Node>
    <NodeName></NodeName>
    <DFProperties>
        <AccessType>
            <Get/>
            <Replace/>
        </AccessType>
        <DFFormat>
            <node/>
        </DFFormat>
        <Occurrence>
            <OneOrMore/>
        </Occurrence>
        <DFType>
            <DDFName></DDFName>
        </DFType>
    </DFProperties>

<Node>
    <NodeName>Latitude</NodeName>
    <DFProperties>
        <AccessType>
            <Get/>
            <Replace/>
        </AccessType>
        <DFFormat>
            <bin/>
        </DFFormat>
        <Occurrence>
            <One/>
        </Occurrence>
        <DFTitle>coordinate

latitude</DFTitle>

    <DFType>
        <MIME>text/plain</MIME>
    </DFType>
</DFProperties>
</Node>

<Node>
    <NodeName>Longitude</NodeName>
    <DFProperties>
        <AccessType>
            <Get/>
            <Replace/>
        </AccessType>
        <DFFormat>
            <bin/>
        </DFFormat>
        <Occurrence>
            <One/>

```



```

        <AccessType>
          <Get/>
          <Replace/>
        </AccessType>
        <DFFormat>
          <int/>
        </DFFormat>
        <Occurrence>
          <One/>
        </Occurrence>
        <DFTitle>TCP port of the V2X application server for
bidirectional transport.</DFTitle>
        <DFType>
          <DDFName/>
        </DFType>
      </DFProperties>
    </Node>

    <Node>
      <NodeName>GeographicalArea</NodeName>
      <DFProperties>
        <AccessType>
          <Get/>
          <Replace/>
        </AccessType>
        <DFFormat>
          <node/>
        </DFFormat>
        <Occurrence>
          <ZeroOrOne/>
        </Occurrence>
        <DFTitle>Geographical Area description.</DFTitle>
        <DFType>
          <MIME>text/plain</MIME>
        </DFType>
      </DFProperties>

      <Node>
        <NodeName>Polygon</NodeName>
        <DFProperties>
          <AccessType>
            <Get/>
            <Replace/>
          </AccessType>
          <DFFormat>
            <node/>
          </DFFormat>
          <Occurrence>
            <One/>
          </Occurrence>
          <DFTitle>Polygon Area description.</DFTitle>
          <DFType>
            <DDFName/>
          </DFType>
        </DFProperties>

        <Node>
          <NodeName></NodeName>
          <DFProperties>
            <AccessType>
              <Get/>
              <Replace/>
            </AccessType>
            <DFFormat>
              <node/>
            </DFFormat>
            <Occurrence>
              <OneOrMore/>
            </Occurrence>
            <DFType>
              <DDFName></DDFName>
            </DFType>
          </DFProperties>

          <Node>
            <NodeName>Coordinates</NodeName>
            <DFProperties>
              <AccessType>

```



```

        <Get/>
        <Replace/>
    </AccessType>
    <DFFormat>
        <node/>
    </DFFormat>
    <Occurrence>
        <One/>
    </Occurrence>
    <DFTitle>Descriptions for geographical
coordinates</DFTitle>

    <DFType>
        <MIME>text/plain</MIME>
    </DFType>
</DFProperties>

<Node>
    <NodeName></NodeName>
    <DFProperties>
        <AccessType>
            <Get/>
            <Replace/>
        </AccessType>
        <DFFormat>
            <node/>
        </DFFormat>
        <Occurrence>
            <OneOrMore/>
        </Occurrence>
        <DFType>
            <DDFName></DDFName>
        </DFType>
    </DFProperties>

    <Node>
        <NodeName>Latitude</NodeName>
        <DFProperties>
            <AccessType>
                <Get/>
                <Replace/>
            </AccessType>
            <DFFormat>
                <bin/>
            </DFFormat>
            <Occurrence>
                <One/>
            </Occurrence>
            <DFTitle>coordinate

        <DFType>
            <MIME>text/plain</MIME>
        </DFType>
    </DFProperties>
</Node>

    <Node>
        <NodeName>Longitude</NodeName>
        <DFProperties>
            <AccessType>
                <Get/>
                <Replace/>
            </AccessType>
            <DFFormat>
                <bin/>
            </DFFormat>
            <Occurrence>
                <One/>
            </Occurrence>
            <DFTitle>coordinate

        <DFType>
            <MIME>text/plain</MIME>
        </DFType>
    </DFProperties>
</Node>
</Node>
</Node>
</Node>

```

```

        </Node>
      </Node>
    </Node>
  </Node>
</Node>
<Node>
  <NodeName>DefaultV2XMBMSConfigs</NodeName>
  <DFProperties>
    <AccessType>
      <Get/>
      <Replace/>
    </AccessType>
    <DFFormat>
      <node/>
    </DFFormat>
    <Occurrence>
      <ZeroOrOne/>
    </Occurrence>
    <DFTitle>Default MBMS configurations.</DFTitle>
    <DFType>
      <DDFName/>
    </DFType>
  </DFProperties>

  <Node>
    <NodeName/>
    <DFProperties>
      <AccessType>
        <Get/>
        <Replace/>
      </AccessType>
      <DFFormat>
        <node/>
      </DFFormat>
      <Occurrence>
        <OneOrMore/>
      </Occurrence>
      <DFTitle>MBMS configurations.</DFTitle>
      <DFType>
        <DDFName/>
      </DFType>
    </DFProperties>

    <Node>
      <NodeName>V2XMBMSConfig</NodeName>
      <DFProperties>
        <AccessType>
          <Get/>
          <Replace/>
        </AccessType>
        <DFFormat>
          <node/>
        </DFFormat>
        <Occurrence>
          <ZeroOrOne/>
        </Occurrence>
        <DFTitle>MBMS configuration.</DFTitle>
        <DFType>
          <DDFName/>
        </DFType>
      </DFProperties>

      <Node>
        <NodeName>TMGI</NodeName>
        <DFProperties>
          <AccessType>
            <Get/>
            <Replace/>
          </AccessType>
          <DFFormat>
            <chr/>
          </DFFormat>
          <Occurrence>
            <One/>
          </Occurrence>
        </DFProperties>
      </Node>
    </Node>
  </Node>
</Node>

```

```

        <DFTitle>TMGI value.</DFTitle>
        <DFType>
            <MIME>text/plain</MIME>
        </DFType>
    </DFProperties>
</Node>

<Node>
    <NodeName>SAIList</NodeName>
    <DFProperties>
        <AccessType>
            <Get/>
            <Replace/>
        </AccessType>
        <DFFormat>
            <node/>
        </DFFormat>
        <Occurrence>
            <One/>
        </Occurrence>
        <DFTitle>Service Area Identifiers.</DFTitle>
        <DFType>
            <MIME>text/plain</MIME>
        </DFType>
    </DFProperties>

    <Node>
        <NodeName></NodeName>
        <DFProperties>
            <AccessType>
                <Get/>
                <Replace/>
            </AccessType>
            <DFFormat>
                <node/>
            </DFFormat>
            <Occurrence>
                <OneOrMore/>
            </Occurrence>
            <DFType>
                <DDFName></DDFName>
            </DFType>
        </DFProperties>

        <Node>
            <NodeName>SAI</NodeName>
            <DFProperties>
                <AccessType>
                    <Get/>
                    <Replace/>
                </AccessType>
                <DFFormat>
                    <chr/>
                </DFFormat>
                <Occurrence>
                    <One/>
                </Occurrence>
                <DFTitle>SAI.</DFTitle>
                <DFType>
                    <MIME>text/plain</MIME>
                </DFType>
            </DFProperties>
        </Node>
    </Node>
</Node>

<Node>
    <NodeName>Frequency</NodeName>
    <DFProperties>
        <AccessType>
            <Get/>
            <Replace/>
        </AccessType>
        <DFFormat>
            <chr/>
        </DFFormat>
        <Occurrence>
            <ZeroOrOne/>
        </Occurrence>
    </DFProperties>
</Node>

```

```

        </Occurrence>
        <DFTitle>EARFCN defined by 3GPP RAN      G.</DFTitle>
        <DFType>
          <MIME>text/plain</MIME>
        </DFType>
        </DFProperties>
      </Node>
    <Node>
      <NodeName>SDPInV2XASMBMSConfig</NodeName>
      <DFProperties>
        <AccessType>
          <Get/>
          <Replace/>
        </AccessType>
        <DFFormat>
          <chr/>
        </DFFormat>
        <Occurrence>
          <One/>
        </Occurrence>
        <DFTitle>V2X MBMS configuration      SDP.</DFTitle>
        <DFType>
          <MIME>text/plain</MIME>
        </DFType>
      </DFProperties>
    </Node>
  </Node>
</Node>
<Node>
  <NodeName>DefaultV2XASAddresses</NodeName>
  <DFProperties>
    <AccessType>
      <Get/>
      <Replace/>
    </AccessType>
    <DFFormat>
      <node/>
    </DFFormat>
    <Occurrence>
      <ZeroOrOne/>
    </Occurrence>
    <DFTitle>V2X server addresses.</DFTitle>
    <DFType>
      <DDFName/>
    </DFType>
  </DFProperties>
  <Node>
    <NodeName/>
    <DFProperties>
      <AccessType>
        <Get/>
        <Replace/>
      </AccessType>
      <DFFormat>
        <node/>
      </DFFormat>
      <Occurrence>
        <OneOrMore/>
      </Occurrence>
      <DFTitle>MBMS configurations.</DFTitle>
      <DFType>
        <DDFName/>
      </DFType>
    </DFProperties>
  </Node>
  <Node>
    <NodeName>TypeOfData</NodeName>
    <DFProperties>
      <AccessType>
        <Get/>
        <Replace/>
      </AccessType>
      <DFFormat>
        <int/>
      </DFFormat>
    </DFProperties>
  </Node>

```

```

        <Occurrence>
          <One/>
        </Occurrence>
        <DFTitle>Type of Data.</DFTitle>
        <DFType>
          <MIME>text/plain</MIME>
        </DFType>
      </DFProperties>
    </Node>

  <Node>
    <NodeName>V2XMessageFamily</NodeName>
    <DFProperties>
      <AccessType>
        <Get/>
        <Replace/>
      </AccessType>
      <DFFormat>
        <int/>
      </DFFormat>
      <Occurrence>
        <ZeroOrOne/>
      </Occurrence>
      <DFTitle>V2X message family.</DFTitle>
      <DFType>
        <MIME>text/plain</MIME>
      </DFType>
    </DFProperties>
  </Node>

  <Node>
    <NodeName>V2XASAddresses</NodeName>
    <DFProperties>
      <AccessType>
        <Get/>
        <Replace/>
      </AccessType>
      <DFFormat>
        <node/>
      </DFFormat>
      <Occurrence>
        <ZeroOrOne/>
      </Occurrence>
      <DFTitle>V2X server addresses.</DFTitle>
      <DFType>
        <DDFName/>
      </DFType>
    </DFProperties>

  <Node>
    <NodeName></NodeName>
    <DFProperties>
      <AccessType>
        <Get/>
        <Replace/>
      </AccessType>
      <DFFormat>
        <node/>
      </DFFormat>
      <Occurrence>
        <OneOrMore/>
      </Occurrence>
      <DFType>
        <DDFName></DDFName>
      </DFType>
    </DFProperties>

  <Node>
    <NodeName>L3Address</NodeName>
    <DFProperties>
      <AccessType>
        <Get/>
        <Replace/>
      </AccessType>
      <DFFormat>
        <chr/>
      </DFFormat>
      <Occurrence>

```

```

        <One/>
      </Occurrence>
      <DFTitle>IP address or FQDN of the V2X application
server.</DFTitle>
    <DFType>
      <DDFName/>
    </DFType>
  </DFProperties>
</Node>

<Node>
  <NodeName>UDPPort</NodeName>
  <DFProperties>
    <AccessType>
      <Get/>
      <Replace/>
    </AccessType>
    <DFFormat>
      <int/>
    </DFFormat>
    <Occurrence>
      <One/>
    </Occurrence>
    <DFTitle>UDP port of the V2X application
server.</DFTitle>
  <DFType>
    <DDFName/>
  </DFType>
</DFProperties>
</Node>

<Node>
  <NodeName>GeographicalArea</NodeName>
  <DFProperties>
    <AccessType>
      <Get/>
      <Replace/>
    </AccessType>
    <DFFormat>
      <node/>
    </DFFormat>
    <Occurrence>
      <ZeroOrOne/>
    </Occurrence>
    <DFTitle>Geographical Area description.</DFTitle>
    <DFType>
      <MIME>text/plain</MIME>
    </DFType>
  </DFProperties>

  <Node>
    <NodeName>Polygon</NodeName>
    <DFProperties>
      <AccessType>
        <Get/>
        <Replace/>
      </AccessType>
      <DFFormat>
        <node/>
      </DFFormat>
      <Occurrence>
        <One/>
      </Occurrence>
      <DFTitle>Polygon Area description.</DFTitle>
      <DFType>
        <DDFName/>
      </DFType>
    </DFProperties>

  <Node>
    <NodeName></NodeName>
    <DFProperties>
      <AccessType>
        <Get/>
        <Replace/>
      </AccessType>
      <DFFormat>
        <node/>
      </DFFormat>
    </DFProperties>
  </Node>

```

```

        </DFFormat>
        <Occurrence>
            <OneOrMore/>
        </Occurrence>
        <DFType>
            <DDFName></DDFName>
        </DFType>
    </DFProperties>

    <Node>
        <NodeName>Coordinates</NodeName>
        <DFProperties>
            <AccessType>
                <Get/>
                <Replace/>
            </AccessType>
            <DFFormat>
                <node/>
            </DFFormat>
            <Occurrence>
                <One/>
            </Occurrence>
            <DFTitle>Descriptions for geographical
coordinates</DFTitle>

            <DFType>
                <MIME>text/plain</MIME>
            </DFType>
        </DFProperties>

    <Node>
        <NodeName></NodeName>
        <DFProperties>
            <AccessType>
                <Get/>
                <Replace/>
            </AccessType>
            <DFFormat>
                <node/>
            </DFFormat>
            <Occurrence>
                <OneOrMore/>
            </Occurrence>
            <DFType>
                <DDFName></DDFName>
            </DFType>
        </DFProperties>

    <Node>
        <NodeName>Latitude</NodeName>
        <DFProperties>
            <AccessType>
                <Get/>
                <Replace/>
            </AccessType>
            <DFFormat>
                <bin/>
            </DFFormat>
            <Occurrence>
                <One/>
            </Occurrence>
            <DFTitle>coordinate

            <DFType>
                <MIME>text/plain</MIME>
            </DFType>
        </DFProperties>
    </Node>

    <Node>
        <NodeName>Longitude</NodeName>
        <DFProperties>
            <AccessType>
                <Get/>
                <Replace/>
            </AccessType>
            <DFFormat>
                <bin/>
            </DFFormat>

```



```

bidirectional transport.</DFTitle>
<DFProperties>
  <AccessType>
    <Get/>
    <Replace/>
  </AccessType>
  <DFFormat>
    <int/>
  </DFFormat>
  <Occurrence>
    <One/>
  </Occurrence>
  <DFTitle>TCP port of the V2X application server for
  <DFType>
    <DDFName/>
  </DFType>
</DFProperties>
</Node>

<Node>
  <NodeName>GeographicalArea</NodeName>
  <DFProperties>
    <AccessType>
      <Get/>
      <Replace/>
    </AccessType>
    <DFFormat>
      <node/>
    </DFFormat>
    <Occurrence>
      <ZeroOrOne/>
    </Occurrence>
    <DFTitle>Geographical Area description.</DFTitle>
    <DFType>
      <MIME>text/plain</MIME>
    </DFType>
  </DFProperties>

  <Node>
    <NodeName>Polygon</NodeName>
    <DFProperties>
      <AccessType>
        <Get/>
        <Replace/>
      </AccessType>
      <DFFormat>
        <node/>
      </DFFormat>
      <Occurrence>
        <One/>
      </Occurrence>
      <DFTitle>Polygon Area description.</DFTitle>
      <DFType>
        <DDFName/>
      </DFType>
    </DFProperties>

  <Node>
    <NodeName></NodeName>
    <DFProperties>
      <AccessType>
        <Get/>
        <Replace/>
      </AccessType>
      <DFFormat>
        <node/>
      </DFFormat>
      <Occurrence>
        <OneOrMore/>
      </Occurrence>
      <DFType>
        <DDFName></DDFName>
      </DFType>
    </DFProperties>

  <Node>
    <NodeName>Coordinates</NodeName>
    <DFProperties>

```

```

coordinates</DFTitle>
    <AccessType>
      <Get/>
      <Replace/>
    </AccessType>
    <DFFormat>
      <node/>
    </DFFormat>
    <Occurrence>
      <One/>
    </Occurrence>
    <DFTitle>Descriptions for geographical
coordinates</DFTitle>
    <DFType>
      <MIME>text/plain</MIME>
    </DFType>
  </DFProperties>
</Node>
<Node>
  <NodeName></NodeName>
  <DFProperties>
    <AccessType>
      <Get/>
      <Replace/>
    </AccessType>
    <DFFormat>
      <node/>
    </DFFormat>
    <Occurrence>
      <OneOrMore/>
    </Occurrence>
    <DFType>
      <DDFName></DDFName>
    </DFType>
  </DFProperties>
</Node>
<Node>
  <NodeName>Latitude</NodeName>
  <DFProperties>
    <AccessType>
      <Get/>
      <Replace/>
    </AccessType>
    <DFFormat>
      <bin/>
    </DFFormat>
    <Occurrence>
      <One/>
    </Occurrence>
    <DFTitle>coordinate
latitude</DFTitle>
    <DFType>
      <MIME>text/plain</MIME>
    </DFType>
  </DFProperties>
</Node>
<Node>
  <NodeName>Longitude</NodeName>
  <DFProperties>
    <AccessType>
      <Get/>
      <Replace/>
    </AccessType>
    <DFFormat>
      <bin/>
    </DFFormat>
    <Occurrence>
      <One/>
    </Occurrence>
    <DFTitle>coordinate
longitude</DFTitle>
    <DFType>
      <MIME>text/plain</MIME>
    </DFType>
  </DFProperties>
</Node>
</Node>
</Node>

```

```

        </Node>
      </Node>
    </Node>
  </Node>
  <Node>
    <NodeName>IPUnicastRoutingV2XServiceList</NodeName>
    <DFProperties>
      <AccessType>
        <Get/>
        <Replace/>
      </AccessType>
      <DFFormat>
        <node/>
      </DFFormat>
      <Occurrence>
        <ZeroOrOne/>
      </Occurrence>
      <DFTitle>Authorized V2X services for V2X communication over LTE-Uu
using existing unicast routing.</DFTitle>
      <DFType>
        <DDFName/>
      </DFType>
    </DFProperties>

    <Node>
      <NodeName></NodeName>
      <DFProperties>
        <AccessType>
          <Get/>
          <Replace/>
        </AccessType>
        <DFFormat>
          <node/>
        </DFFormat>
        <Occurrence>
          <ZeroOrMore/>
        </Occurrence>
        <DFType>
          <DDFName></DDFName>
        </DFType>
      </DFProperties>

    <Node>
      <NodeName>V2XServiceIdentifier</NodeName>
      <DFProperties>
        <AccessType>
          <Get/>
          <Replace/>
        </AccessType>
        <DFFormat>
          <int/>
        </DFFormat>
        <Occurrence>
          <One/>
        </Occurrence>
        <DFTitle>V2X service identifier.</DFTitle>
        <DFType>
          <DDFName></DDFName>
        </DFType>
      </DFProperties>
    </Node>
  </Node>
</Node>
</Node>
</Node>
</Node>
<Node>
  <NodeName>Ext</NodeName>
  <DFProperties>

```

```
<AccessType>
  <Get/>
</AccessType>
<DFFormat>
  <node/>
</DFFormat>
<Occurrence>
  <ZeroOrOne/>
</Occurrence>
<DFTitle>A collection of all extension objects.</DFTitle>
<DFType>
  <DDFName/>
</DFType>
</DFProperties>
</Node>
</Node>
</MgmtTree>
```

Annex B (informative): Change history

Change history						
Date	TSG #	TSG Doc.	CR	Rev	Subject/Comment	New
2016-10		-	-	-	TS skeleton generated for submission at CT1#100	0.0.0
2016-10	CT1#100	-	-	-	Implementation of C1-164497. Editorial fixes.	0.1.0
2016-11	CT1#101	-	-	-	Implementation of C1-165327, C1-165329 and C1-165390. Editorial fixes.	0.2.0
2016-11	CT-74	CP-160704			Version 1.0.0 created for presentation for information to CT plenary	1.0.0
2017-01	CT1#101bis	-	-	-	Implementation of C1-170014, C1-170096, C1-170243, C1-170339, C1-170344, C1-170348 and C1-170349.	1.1.0
2017-02	CT1#102	-	-	-	Implementation of C1-170919, C1-170922 and C1-170993. Editorial fixes.	1.2.0
2017-02	CT-75	CP-170155			Version 2.0.0 created for presentation for approval to CT plenary	2.0.0
2017-03	CT-75				Version 14.0.0 created after approval at CT-75	14.0.0
2017-06	CT-76	CP-171091	0001	1	V2X communication over LTE-Uu - configuration for existing unicast routing for V2X messages of a V2X service with a V2X service identifier	14.1.0
2017-06	CT-76	CP-171091	0002		Addition of PC5 privacy configuration parameters to V2X MO	14.1.0
2017-06	CT-76	CP-171091	0003	1	Correction of reference to the definition of RadioParameterContents	14.1.0
2017-06	CT-76	CP-171091	0004		Correction of default destination Layer-2 ID	14.1.0
2017-06	CT-76	CP-171091	0005	1	Removal of Editor's note on the destination layer 2 ID	14.1.0
2017-09	CT-77	CP-172110	0006		Supporting cross-carrier operation for V2X communication over PC5	14.2.0
2017-09	CT-77	CP-172110	0007	3	MO for service type and V2X frequency mapping rule	14.2.0
2017-12	CT-78	CP-173056	0009		Adding definition of not served by E-UTRAN for V2X communication over PC5	14.3.0
2017-12	CT-78	CP-173056	0010		Clarification on the number of coordinates in a geographical area	14.3.0
2018-06	SA-80	-	-	-	Update to Rel-15 version (MCC)	15.0.0

Change history							
Date	Meeting	TDoc	CR	Rev	Cat	Subject/Comment	New version
2018-09	CT-81	CP-182120	0012		A	"V2XServiceIDtoV2XFrequencyMappingRule" should be under the node "V2XoverPC5"	15.1.0
2018-09	CT-81	CP-182152	0013	1	B	MO for service type and Tx profile mapping rules	15.1.0
2018-09	CT-81	CP-182120	0015		A	Correction of DDF to be valid XML document	15.1.0
2018-09	CT-81	CP-182152	0016		F	Correction for configuration parameters for reliable transmission over V2X PC5	15.1.0
2019-09	CT-85	CP-192071	0018	1	F	Correcting undefined datatype: network access point object	16.0.0
2020-06	CT-88e	CP-201116	0021	3	B	V2X MO update for V2X over NR-PC5	16.1.0
2020-06	CT-88e	CP-201116	0022	1	B	DDF update for V2X over NR-PC5	16.1.0
2020-09	CT-89e	CP-202192	0023	1	F	Addition of support for V2X services over LTE-Uu interface using TCP	16.2.0
2022-04	CT-95e	-	-	-	-	Update to Rel-17 version (MCC)	17.0.0

History

Document history		
V17.0.0	April 2022	Publication