

ETSI TS 124 239 V16.0.0 (2020-11)



**Digital cellular telecommunications system (Phase 2+) (GSM);
Universal Mobile Telecommunications System (UMTS);
LTE;
Flexible Alerting (FA) using IP Multimedia (IM)
Core Network (CN) subsystem;
Protocol specification
(3GPP TS 24.239 version 16.0.0 Release 16)**



Reference

RTS/TSGC-0124239vg00

Keywords

GSM,LTE,UMTS

ETSI

650 Route des Lucioles
F-06921 Sophia Antipolis Cedex - FRANCE

Tel.: +33 4 92 94 42 00 Fax: +33 4 93 65 47 16

Siret N° 348 623 562 00017 - NAF 742 C
Association à but non lucratif enregistrée à la
Sous-Préfecture de Grasse (06) N° 7803/88

Important notice

The present document can be downloaded from:

<http://www.etsi.org/standards-search>

The present document may be made available in electronic versions and/or in print. The content of any electronic and/or print versions of the present document shall not be modified without the prior written authorization of ETSI. In case of any existing or perceived difference in contents between such versions and/or in print, the prevailing version of an ETSI deliverable is the one made publicly available in PDF format at www.etsi.org/deliver.

Users of the present document should be aware that the document may be subject to revision or change of status.

Information on the current status of this and other ETSI documents is available at

<https://portal.etsi.org/TB/ETSIDeliverableStatus.aspx>

If you find errors in the present document, please send your comment to one of the following services:

<https://portal.etsi.org/People/CommiteeSupportStaff.aspx>

Copyright Notification

No part may be reproduced or utilized in any form or by any means, electronic or mechanical, including photocopying and microfilm except as authorized by written permission of ETSI.

The content of the PDF version shall not be modified without the written authorization of ETSI.

The copyright and the foregoing restriction extend to reproduction in all media.

© ETSI 2020.

All rights reserved.

DECT™, **PLUGTESTS™**, **UMTS™** and the ETSI logo are trademarks of ETSI registered for the benefit of its Members.

3GPP™ and **LTE™** are trademarks of ETSI registered for the benefit of its Members and of the 3GPP Organizational Partners.

oneM2M™ logo is a trademark of ETSI registered for the benefit of its Members and of the oneM2M Partners.

GSM® and the GSM logo are trademarks registered and owned by the GSM Association.

Intellectual Property Rights

Essential patents

IPRs essential or potentially essential to normative deliverables may have been declared to ETSI. The information pertaining to these essential IPRs, if any, is publicly available for **ETSI members and non-members**, and can be found in ETSI SR 000 314: *"Intellectual Property Rights (IPRs); Essential, or potentially Essential, IPRs notified to ETSI in respect of ETSI standards"*, which is available from the ETSI Secretariat. Latest updates are available on the ETSI Web server (<https://ipr.etsi.org/>).

Pursuant to the ETSI IPR Policy, no investigation, including IPR searches, has been carried out by ETSI. No guarantee can be given as to the existence of other IPRs not referenced in ETSI SR 000 314 (or the updates on the ETSI Web server) which are, or may be, or may become, essential to the present document.

Trademarks

The present document may include trademarks and/or tradenames which are asserted and/or registered by their owners. ETSI claims no ownership of these except for any which are indicated as being the property of ETSI, and conveys no right to use or reproduce any trademark and/or tradename. Mention of those trademarks in the present document does not constitute an endorsement by ETSI of products, services or organizations associated with those trademarks.

Legal Notice

This Technical Specification (TS) has been produced by ETSI 3rd Generation Partnership Project (3GPP).

The present document may refer to technical specifications or reports using their 3GPP identities. These shall be interpreted as being references to the corresponding ETSI deliverables.

The cross reference between 3GPP and ETSI identities can be found under <http://webapp.etsi.org/key/queryform.asp>.

Modal verbs terminology

In the present document "**shall**", "**shall not**", "**should**", "**should not**", "**may**", "**need not**", "**will**", "**will not**", "**can**" and "**cannot**" are to be interpreted as described in clause 3.2 of the [ETSI Drafting Rules](#) (Verbal forms for the expression of provisions).

"**must**" and "**must not**" are **NOT** allowed in ETSI deliverables except when used in direct citation.

Contents

Intellectual Property Rights	2
Legal Notice	2
Modal verbs terminology.....	2
Foreword.....	5
1 Scope	6
2 References	6
3 Definitions and abbreviations.....	6
3.1 Definitions	6
3.2 Abbreviations	7
4 Flexible Alerting (FA).....	7
4.1 Introduction	7
4.2 Description	7
4.2.1 General description	7
4.3 Operational requirements	8
4.3.1 Provision/withdrawal	8
4.3.2 Requirements on the originating network side.....	8
4.3.3 Requirements on the terminating network side.....	9
4.4 Syntax requirements	9
4.5 Signalling procedures	9
4.5.1 General.....	9
4.5.2 Activation/deactivation	9
4.5.2.1 General	9
4.5.2.2 Demand member activation of a subscriber's default FA group(s)	9
4.5.2.3 Demand member activation of a specified FA group.....	9
4.5.2.4 Demand member deactivation of a subscriber's default FA group(s).....	10
4.5.2.5 Demand member deactivation of a specified FA group	10
4.5.3 Registration/erasure	10
4.5.4 Interrogation	10
4.5.4.1 General	10
4.5.4.2 Interrogation using Ut interface	10
4.5.4.3 Interrogation using the SIP-based user configuration	10
4.5.5 Invocation and operation	10
4.5.5.1 Actions at the AS serving the originating UE	10
4.5.5.2 Actions at the AS serving the pilot identity	10
4.6 Interaction with other services.....	11
4.6.1 Communication session Hold (HOLD).....	11
4.6.2 Terminating Identification Presentation (TIP).....	11
4.6.3 Terminating Identification Restriction (TIR).....	11
4.6.4 Originating Identification Presentation (OIP).....	11
4.6.5 Originating Identification Restriction (OIR).....	11
4.6.6 Conference (CONF).....	12
4.6.7 Communication DIVersion services (CDIV).....	12
4.6.7.1 Communication Forwarding Unconditional (CFU)	12
4.6.7.2 Communication Forwarding Busy (CFB)	12
4.6.7.3 Communication Forwarding No Reply (CFNR)	12
4.6.7.4 Communication Forwarding Not Reachable (CFNRc)	12
4.6.7.5 Communication Deflection (CD).....	13
4.6.7.6 Communication Forwarding on Not Logged-In (CFNL).....	13
4.6.8 Message Waiting Indication (MWI)	13
4.6.9 Communication Barring (CB).....	13
4.6.10 Explicit Communication Transfer (ECT)	13
4.6.11 Enhanced Calling Name (eCNAM)	13
4.6.12 Multi-Device (MuD).....	13
4.6.13 Multi-Identity (MiD).....	14

4.7	Parameter values (timers).....	14
4.8	Service configuration	14
4.8.1	General.....	14
4.8.2	Data semantics	14
4.8.3	XML schema	14
Annex A (informative): Signalling flows		16
A.1	Scope of signalling flows	16
A.2	Introduction	16
A.3	FA model signalling flow	16
A.3.1	Introduction	16
A.3.2	FA when UE#1 and UE#2 have resources available and UE#3 does not have required resources available	16
Annex B (informative): Example of filter criteria.....		23
Annex C (informative): Change history		24
History		25

Foreword

This Technical Specification has been produced by the 3rd Generation Partnership Project (3GPP).

The contents of the present document are subject to continuing work within the TSG and may change following formal TSG approval. Should the TSG modify the contents of the present document, it will be re-released by the TSG with an identifying change of release date and an increase in version number as follows:

Version x.y.z

where:

- x the first digit:
 - 1 presented to TSG for information;
 - 2 presented to TSG for approval;
 - 3 or greater indicates TSG approved document under change control.
- y the second digit is incremented for all changes of substance, i.e. technical enhancements, corrections, updates, etc.
- z the third digit is incremented when editorial only changes have been incorporated in the document.

1 Scope

The present document provides the protocol details for the Flexible Alerting supplementary service in the IP Multimedia (IM) Core Network (CN) subsystem based on the requirements from 3GPP TS 22.173 [2].

Flexible Alerting (FA) causes a call to a pilot identity to branch the call into several legs to alert several termination addresses (group members) simultaneously. The first leg to be answered is connected to the calling party. The other call legs are abandoned.

The present document is applicable to User Equipment (UE) and Application Servers (AS) which are intended to support the FA supplementary service.

2 References

The following documents contain provisions which, through reference in this text, constitute provisions of the present document.

- References are either specific (identified by date of publication, edition number, version number, etc.) or non-specific.
- For a specific reference, subsequent revisions do not apply.
- For a non-specific reference, the latest version applies. In the case of a reference to a 3GPP document (including a GSM document), a non-specific reference implicitly refers to the latest version of that document *in the same Release as the present document*.

- [1] 3GPP TR 21.905: "Vocabulary for 3GPP Specifications".
- [2] 3GPP TS 22.173: "IP Multimedia Core Network Subsystem (IMS) Multimedia Telephony Service and supplementary services; Stage 1".
- [3] 3GPP TS 23.002: "Network architecture".
- [4] 3GPP TS 24.238: "Session Initiation Protocol (SIP) based user configuration; Stage 3".
- [5] 3GPP TS 24.229: "Internet Protocol (IP) multimedia call control protocol based on Session Initiation Protocol (SIP) and Session Description Protocol (SDP); Stage 3".
- [6] 3GPP TS 24.623: "Extensible Markup Language (XML) Configuration Access Protocol (XCAP) over the Ut interface for Manipulating Simulation Services".
- [7] 3GPP TS 29.228: "IP Multimedia (IM) Subsystem Cx and Dx interfaces; Signalling flows and message contents".
- [8] 3GPP TS 24.196: "Technical Specification Group Core Network and Terminals; Enhanced Calling Name".

3 Definitions and abbreviations

3.1 Definitions

For the purposes of the present document, the terms and definitions given in 3GPP TR 21.905 [1] and the following apply. A term defined in the present document takes precedence over the definition of the same term, if any, in 3GPP TR 21.905 [1].

3.2 Abbreviations

For the purposes of the present document, the abbreviations given in 3GPP TR 21.905 [1] and the following apply. An abbreviation defined in the present document takes precedence over the definition of the same abbreviation, if any, in 3GPP TR 21.905 [1].

AS	Application Server
CS	Circuit Switched
CN	Core Network
FA	Flexible Alerting
IP	Internet Protocol
IM	IP Multimedia
MiD	Multi-iDentity
MMTEL	Multimedia Telephony
MuD	Multi-Device

4 Flexible Alerting (FA)

4.1 Introduction

Flexible Alerting (FA) causes a call to a Pilot Identity to branch the call into several legs to alert several termination addresses (group members) simultaneously. Additional calls may be delivered to the FA Pilot Identity at any time. The first leg to be answered is connected to the calling party. The other call legs are abandoned.

The members of an FA group are described by a list of termination addresses.

4.2 Description

4.2.1 General description

FA may be used for either a single user or multiple users. The difference between the two is in determining when the FA group is busy. In the single user case, the group is considered to be busy when one of the members is considered to be busy. In the multiple user case, the group is considered to be busy when all of the accessible members are considered to be busy. A member is considered to be busy when it cannot accept the presentation of another call.

The FA pilot identity may have features to manage incoming calls (e.g., Incoming Communications Barring). These features should take precedence over the corresponding features of individual members as described in subclause 4.6.

If an FA pilot identity is an FA member Identity, the FA member loses his or her individual incoming call features. In this case, the FA member's incoming call features are superseded by the incoming call features of the FA pilot identity.

If an FA pilot identity is not an FA member Identity, the features of the FA pilot identity may be changed only through user or service provider configuration.

FA does not affect the ability of an FA member to originate calls. FA may affect the ability of an FA member to receive calls.

If an FA member has only a single identity that is the same as the FA pilot identity, the FA member may not receive calls except through the FA pilot identity.

If an FA member has an identity different than the FA pilot identity, the FA member may receive calls as an individual as well as calls through the FA pilot identity. Such an FA member may use revertive calling (i.e., a call to itself) for other purposes, such as retrieval of voice mail.

4.3 Operational requirements

4.3.1 Provision/withdrawal

The FA service may be provided after prior arrangement with the service provider. The establishment of the initial constituency (membership) of the FA group, along with additions to or subtractions from the set of group members, is performed by the service provider.

The FA service may be withdrawn at the subscriber's request or for administrative reasons. Withdrawal of the FA service means dissolution of the FA group and results in calls to the Pilot Identity being treated as calls to a vacant identity. Withdrawal of the FA service is performed by the service provider.

As determined by service provider provisioning, the FA group may have the following subscription options, as summarized in table 4.3.1-1.

Table 4.3.1-1: FA group subscription options

Subscription option values	Values
Type	<ul style="list-style-type: none"> - Single User. The FA group is considered to be busy when any member of the group is considered to be busy. - Multiple Users. The FA group is considered to be busy when all accessible members of the group are considered to be busy.

As determined by service provider provisioning, the FA member may have the following subscription options, as summarized in table 4.3.1-2.

Table 4.3.1-2: FA member subscription options

Subscription option values	Values
Membership	<ul style="list-style-type: none"> - Demand. An FA member is authorized to activate or deactivate his or her membership in the FA group(s). - Permanent. An FA member is always a member of his or her registered FA group(s).

If an FA group is of type 'demand activation', any configured FA member is able to, by means of user configuration, change their status in the FA group from 'active' to 'inactive' or from 'inactive' to 'active'. The FA member status options are summarized in table 4.3.1-3.

Table 4.3.1-3: FA member status options

Subscription option values	Values
Status	<ul style="list-style-type: none"> - Active. An FA member is eligible to be alerted when a call is placed to the Pilot Identity. - Inactive. An FA member is not eligible to be alerted when a call is placed to the Pilot Identity..

Available user configuration actions for FA are described in subclause 4.5.2.

For user configuration of FA, the SIP-based user configuration capability as described in 3GPP TS 24.238 [4] or the Ut interface as described in 3GPP TS 24.623 [6] could be used. More detail is described in subclause 4.8.

Other possibilities for provisioning could be used too, like web based provisioning or pre-provisioning by the operator.

4.3.2 Requirements on the originating network side

There are no requirements on the originating network side for FA. FA is a terminating network side service.

4.3.3 Requirements on the terminating network side

The public user identity that represents the pilot identity of the FA group has an always-registered presence on the IM CN subsystem. The pilot identity is associated with a typical IM CN subsystem user service profile.

4.4 Syntax requirements

There are no special SIP syntax requirements for the FA service. The FA service is invoked when an IM CN subsystem session is terminated to the pilot identity of an FA group.

4.5 Signalling procedures

4.5.1 General

For user configuration of the FA service by a member of the FA group, either the Ut interface or the SIP-based user configuration capability (as specified by 3GPP TS 24.238 [4]) should be used.

The enhancements to the XML schema for use over the Ut interface are described in subclause 4.8.

NOTE: Other possibilities for user configuration, such as web-based provisioning, are outside the scope of the present document.

4.5.2 Activation/deactivation

4.5.2.1 General

The FA service is activated at provisioning and deactivated at withdrawal.

For an FA group that is of type 'demand activation', activation or deactivation of membership is accomplished by means of user configuration and may be achieved by using either:

- the Ut interface using XCAP as enabling protocol as described in 3GPP TS 24.623 [6]; or
- SIP based user configuration as described in 3GPP TS 24.238 [3];

NOTE: Other possibilities for user configuration, such as web-based provisioning or pre-provisioning by the operator are outside the scope of the present document, but are not precluded.

The enhancements to the XML schema for use over the Ut interface are described in subclause 4.9.

4.5.2.2 Demand member activation of a subscriber's default FA group(s)

For an FA group that is of type 'demand activation', an FA member may activate his or her membership in the subscriber's default FA group(s) by specifying the FA membership activation feature code:

An example of the code is: *FC

If the activation is accepted, the system shall indicate success with feature confirmation treatment.

4.5.2.3 Demand member activation of a specified FA group

For an FA group that is of type 'demand activation', an FA member may activate his or her membership in a particular FA group by specifying the FA membership activation feature code and a specific FA pilot identity:

An example of the code is: *FC + FA pilot identity

If the activation is accepted, the system shall indicate success with feature confirmation treatment.

4.5.2.4 Demand member deactivation of a subscriber's default FA group(s)

For an FA group that is of type 'demand activation', an FA member may deactivate his or her membership in the subscriber's default FA group(s) by specifying the FA membership deactivation feature code:

An example of the code is: *FC0

If the deactivation is accepted, the system shall indicate success with feature confirmation treatment.

4.5.2.5 Demand member deactivation of a specified FA group

For an FA group that is of type 'demand activation', an FA member may deactivate his or her membership in a particular FA group by specifying the FA membership deactivation feature code and a specific FA pilot identity:

An example of the code is: *FC0 + FA pilot identity

If the deactivation is accepted, the system shall indicate success with feature confirmation treatment.

4.5.3 Registration/erasure

Individual members of the FA group may be added or deleted at any time by the service provider.

4.5.4 Interrogation

4.5.4.1 General

For interrogation, the mechanisms described in subclause 4.5.1 should be used.

4.5.4.2 Interrogation using Ut interface

The enhancements to the XML schema for use over the Ut interface are described in subclause 4.9.

4.5.4.3 Interrogation using the SIP-based user configuration

For an FA group that is of type 'demand activation', an FA member may interrogate his or her membership status in the subscriber's default FA group(s) by specifying the FA membership interrogation feature code:

An example of the code is: *FC1

For an FA group that is of type 'demand activation', an FA member may interrogate his or her membership status in a particular FA group by specifying the FA membership interrogation feature code and a specific FA pilot identity:

An example of the code is: *FC1 + FA pilot identity

NOTE 1: The response to such interrogation is not specified for the FA service. AS interactions with the MRF over the CR reference point or a solution based on IVR can be used as a possible interrogation response.

4.5.5 Invocation and operation

4.5.5.1 Actions at the AS serving the originating UE

There are no procedures at the originating AS relevant to the FA service.

4.5.5.2 Actions at the AS serving the pilot identity

Procedures specified in 3GPP TS 24.229 [5] for an AS acting as a routing B2BUA shall apply, with the additions described in this subclause.

The AS shall support procedures of notification about registration status defined in subclause 5.7.1.1 of 3GPP TS 24.229 [5].

Upon receiving an incoming SIP INVITE request destined to the pilot identity, based on operator policy the AS shall either:

- 1) Alert the UEs of FA member identities in parallel by sending the SIP INVITE request to all the member identities within the FA group; or
- 2) alert the UEs of the FA member identities sequentially by sending the SIP INVITE request to the Public User Identities of the FA group or to their specific registered UEs in sequence, either progressing through the group based on failure to respond from the UE (the nature of the failures used is based on nature of the implementation) or on a fixed and locally configured timer.

NOTE 1: The order in which members of the FA group and their registered UEs are alerted depends on application-specific criteria (including static preferences, last used device, last registered device).

NOTE 2: Two mechanisms for the AS to select a specific registered UE for a registered Public User Identity are, 1) the AS can set the Request-URI of the INVITE request to the public GRUU of the selected UE, if available, 2) insert in the INVITE request the Accept-Contact header field containing a sip.instance media feature tag equal to the instance-id associated to the selected UE and the "require" and the "explicit" tags.

Upon receiving a SIP 200 (OK) response to the SIP INVITE request from a member UE, the AS shall:

- send SIP CANCEL request to cancel any outstanding SIP INVITE request other member UEs that have not sent a final response; and
- send the SIP 200 (OK) response for the SIP INVITE request to the originating UE.

For a single-user FA group, if the AS receives SIP 486 (Busy Here) response from any of the member UEs before receiving SIP 2xx responses, the AS shall:

- send SIP CANCEL request to cancel any outstanding SIP INVITE request other member UEs that have not sent a final response; and
- send the SIP 486 (Busy Here) response to the originating UE.

For a multiple-user FA group, if the AS receives SIP 486 (Busy Here) responses from each (all) of the member UEs, the AS shall send a SIP 486 (Busy Here) response to the originating UE.

4.6 Interaction with other services

4.6.1 Communication session Hold (HOLD)

No impact, i.e. neither service shall affect the operation of the other service.

4.6.2 Terminating Identification Presentation (TIP)

If the FA pilot identity did not apply TIR, the termination identification is the FA pilot identity.

4.6.3 Terminating Identification Restriction (TIR)

If the FA pilot identity has TIR activated, the termination identification is not presented.

4.6.4 Originating Identification Presentation (OIP)

If the FA pilot identity has OIP activated, incoming calls to the FA pilot identity apply OIP to the members of the FA group.

4.6.5 Originating Identification Restriction (OIR)

No impact, i.e. neither service shall affect the operation of the other service.

4.6.6 Conference (CONF)

No impact, i.e. neither service shall affect the operation of the other service.

4.6.7 Communication DIVersion services (CDIV)

4.6.7.1 Communication Forwarding Unconditional (CFU)

CFU is applicable to FA. If CFU is active for the Pilot Identity, the FA AS shall perform the procedures related to CFU prior to executing the FA service.

CFU of the FA Pilot Identity takes precedence over CFU of the individual FA members. That is, if both the FA Pilot Identity and an FA member have CFU active, CFU treatment is determined by the Pilot Identity's service profile.

A forwarded communication can invoke the FA supplementary service.

4.6.7.2 Communication Forwarding Busy (CFB)

CFB of the FA Pilot Identity shall apply to calls to the Pilot Identity when CFB is active and the FA group is considered to be busy. CFB takes precedence over FA. If CFB is active for the Pilot Identity, the FA AS shall perform the procedures related to CFB prior to executing the FA service.

CFB of the FA Pilot Identity takes precedence over CFB of the individual FA members. That is, if both the FA Pilot Identity and an FA member have CFB active, CFB treatment is determined by the Pilot Identity's service profile.

If while a call to the Pilot Identity remains in progress, and the FA group has not yet been considered busy, yet an individual call leg (i.e. FA member) is reported 'busy' and its associated service profile does have CFB active, the CFB service should be invoked on behalf of that member.

A forwarded communication can invoke the FA supplementary service.

4.6.7.3 Communication Forwarding No Reply (CFNR)

CFNR of the FA Pilot Identity shall apply to calls to the Pilot Identity when CFNR is active and the call is not or cannot be answered for reason that there is no reply from any of the FA members. CFNR takes precedence over FA. If CFNR is active for the Pilot Identity, the FA AS shall perform the procedures related to CFNR prior to executing the FA service.

CFNR of the FA Pilot Identity takes precedence over CFNR of the individual FA members. That is, if both the FA Pilot Identity and an FA member have CFNR active, CFNR treatment is determined by the Pilot Identity's service profile.

If while a call to the Pilot Identity remains in progress, and the criteria to invoke the CFNR service is met with respect to an individual call leg (i.e. FA member), the CFNR service should be invoked on behalf of that member.

If FA group is of type "Multiple Users", and not all users return a SIP 486 (Busy Here) response, and the other FA members within the FA group do not reply or are not logged in, then CFNR of the FA Pilot Identity shall apply.

A forwarded communication can invoke the FA supplementary service.

4.6.7.4 Communication Forwarding Not Reachable (CFNRc)

CFNRc of the FA Pilot Identity shall apply to calls to the Pilot Identity when CFNRc is active and the call is not or cannot be answered for reason that none of the FA members is reachable. CFNRc takes precedence over FA. If CFNRc is active for the Pilot Identity, the FA AS shall perform the procedures related to CFNRc prior to executing the FA service.

CFNRc of the FA Pilot Identity takes precedence over CFNRc of the individual FA members. That is, if both the FA Pilot Identity and an FA member have CFNRc active, CFNRc treatment is determined by the Pilot Identity's service profile.

If while a call to the Pilot Identity remains in progress, and the criteria to invoke the CFNRc service is met with respect to an individual call leg (i.e. FA member), the CFNRc service should be invoked on behalf of that member.

A forwarded communication can invoke the FA supplementary service.

4.6.7.5 Communication Deflection (CD)

No impact, i.e. neither service shall affect the operation of the other service. CD does not apply to the Pilot Identity.

A forwarded communication can invoke the FA supplementary service.

4.6.7.6 Communication Forwarding on Not Logged-In (CFNL)

CFNL of the FA Pilot Identity shall apply to calls to the Pilot Identity when CFNL is active and the call is not or cannot be answered for reason that none of the FA members is logged-in. CFNL takes precedence over FA. If CFNL is active for the Pilot Identity, the FA AS shall perform the procedures related to CFNL prior to executing the FA service.

CFNL of the FA Pilot Identity takes precedence over CFNL of the individual FA members. That is, if both the FA Pilot Identity and an FA member have CFNL active, CFNL treatment is determined by the Pilot Identity's service profile.

If while a call to the Pilot Identity remains in progress, and the criteria to invoke the CFNL service is met with respect to an individual call leg (i.e. FA member), the CFNL service should be invoked on behalf of that member.

A forwarded communication can invoke the FA supplementary service.

4.6.8 Message Waiting Indication (MWI)

No impact, i.e. neither service shall affect the operation of the other service.

4.6.9 Communication Barring (CB)

Incoming Communications Barring (ICB) and Anonymous Call Rejection (ACR) of the FA pilot identity take precedence over FA. That is, calls to the FA pilot identity with ICB/ACR active are checked for the ICB/ACR first. If the call is not allowed by ICB/ACR, the call is refused. If the call is accepted by ICB/ACR, the call is given FA treatment.

ICB/ACR may apply for individual FA members for calls to the FA pilot identity. FA calls destined to a particular FA member may, after screening against the FA pilot identity, be screened against a FA member's screening list to prevent the unintended delivery of a call to a member. If the second screening fails, the member should be considered inaccessible and the call should be attempted to be delivered to another member. The screening of all the members pertaining to an FA group shall be done so that all members are alerted at nearly the same time.

4.6.10 Explicit Communication Transfer (ECT)

No impact, i.e. neither service shall affect the operation of the other service.

4.6.11 Enhanced Calling Name (eCNAM)

If the FA Pilot has eCNAM activated, incoming calls to the FA Pilot shall apply eCNAM to the members of the FA group.

The eCNAM metadata as specified in 3GPP TS 24.196 [8] that is obtained from analytics shall be based on the FA Pilot and not the individual members' identity.

NOTE: Analytics can sometimes include/process information about the called party. Therefore, it is noted that in an FA group, the only called party identity to be used for analytics is that of the Pilot and not of other members of the FA.

4.6.12 Multi-Device (MuD)

No impact. Neither service shall affect the operation of the other service.

4.6.13 Multi-Identity (MiD)

Terminating MiD service is competing with the FA.

4.7 Parameter values (timers)

No timers for FA service are defined.

4.8 Service configuration

4.8.1 General

Flexible Alerting documents are sub-trees of the *simservs* XML document specified in 3GPP TS 24.623 [6]. As such, Originating Identity documents use the XCAP application usage in 3GPP TS 24.623 [6].

Data semantics: The semantics of the Flexible Alerting XML configuration document is specified in subclause 4.8.2.

XML schema: Implementations in compliance with the present document shall implement the XML schema that minimally includes the XML Schema defined in subclause 4.8.3 and the *simservs* XML schema specified in subclause 6.3 of 3GPP TS 24.623 [6].

An instance of an Flexible Alerting document is shown:

```
<?xml version="1.0" encoding="UTF-8"?>
<simservs xmlns="http://uri.etsi.org/ngn/params/xml/simservs/xcap"
xmlns:xsi="http://www.w3.org/2001/XMLSchema-instance">
  <flexible-alerting-default active="true"/>

  <flexible-alerting-specific active="true">
    <identity>sip:pilot_identity@homel.net</identity>
  </flexible-alerting-specific>
</simservs>
```

4.8.2 Data semantics

For an FA group that is of type 'demand activation':

- an FA member may activate or deactivate their membership from their default FA groups using the active attribute of the <flexible-alerting-default> service element.
- an FA member may activate or deactivate their membership from a particular FA group identified by its Pilot Identity using the active attribute of the <identity> service element. The Pilot Identity of the FA group is configured in the <identity> element as a URI.
- an FA member may deactivate all their Specific FA groups by setting the active attribute of the <flexible-alerting-specific> service element to "false".

4.8.3 XML schema

```
<?xml version="1.0" encoding="UTF-8"?>
<xs:schema targetNamespace="http://uri.etsi.org/ngn/params/xml/simservs/xcap"
xmlns:ss="http://uri.etsi.org/ngn/params/xml/simservs/xcap"
xmlns:xs="http://www.w3.org/2001/XMLSchema" elementFormDefault="qualified"
attributeFormDefault="unqualified">
  <xs:include schemaLocation="XCAP.xsd"/>
  <xs:element name="flexible-alerting-default" type="ss:simservType"
substitutionGroup="ss:absService">
    <xs:annotation>
      <xs:documentation>Flexible Alerting Default Groups Membership
      </xs:documentation>
    </xs:annotation>
  </xs:element>
```

```
<xs:element name="flexible-alerting-specific" substitutionGroup="ss:absService">
  <xs:annotation>
    <xs:documentation>Flexible Alerting Specific Groups Membership
    </xs:documentation>
  </xs:annotation>
  <xs:complexType>
    <xs:complexContent>
      <xs:extension base="ss:simservType">
        <xs:sequence>
          <xs:element name="identity" minOccurs="0" maxOccurs="unbounded">
            <xs:complexType>
              <xs:simpleContent>
                <xs:extension base="xs:anyURI">
                  <xs:attribute name="active" type="xs:boolean" use="optional"
                    default="true"/>
                </xs:extension>
              </xs:simpleContent>
            </xs:complexType>
          </xs:element>
          <xs:any namespace="##other" minOccurs="0" maxOccurs="unbounded"
            processContents="lax"/>
        </xs:sequence>
        <xs:anyAttribute namespace="##other"/>
      </xs:extension>
    </xs:complexContent>
  </xs:complexType>
</xs:element>
</xs:schema>
```

Annex A (informative): Signalling flows

A.1 Scope of signalling flows

This annex gives examples of signalling flows for the FA service within the IP Multimedia (IM) Core Network (CN) subsystem based on the Session Initiation Protocol (SIP).

A.2 Introduction

A.3 FA model signalling flow

A.3.1 Introduction

The following flow shows the establishment of a session between UE#1 and UE#2. The following flow is included:

- subclause A.3.2 shows FA, when UE#1 and UE#2 have resources available and UE#3 does not have required resources available.

A.3.2 FA when UE#1 and UE#2 have resources available and UE#3 does not have required resources available

Figure A.3.2-1 and figure A.3.2-2 show the FA service invoked when UE#1 sends an INVITE request to the Pilot Identity. UE#2 and UE#3 have registered public user identities that are included in the FA group. In this example, UE#1 and UE#2 have resources available prior to session initiation, whereas UE#3 does not have the required resources available before it receives the initial INVITE request. This example assumes that all the UEs involved in this session support the IMS Multimedia Telephony Communication Service.

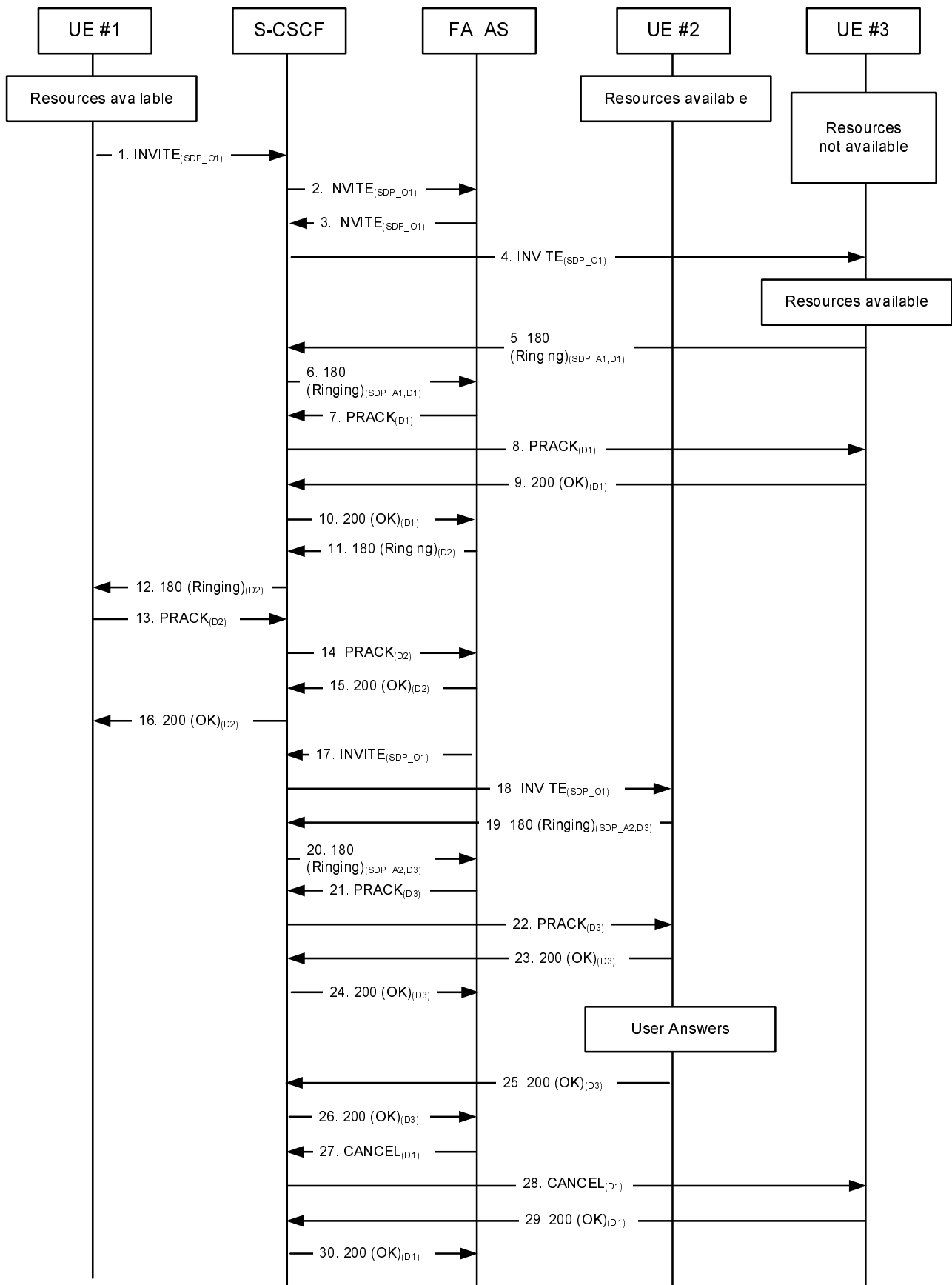

Figure A.3.2-1: FA, UE#3 does not have required resources available

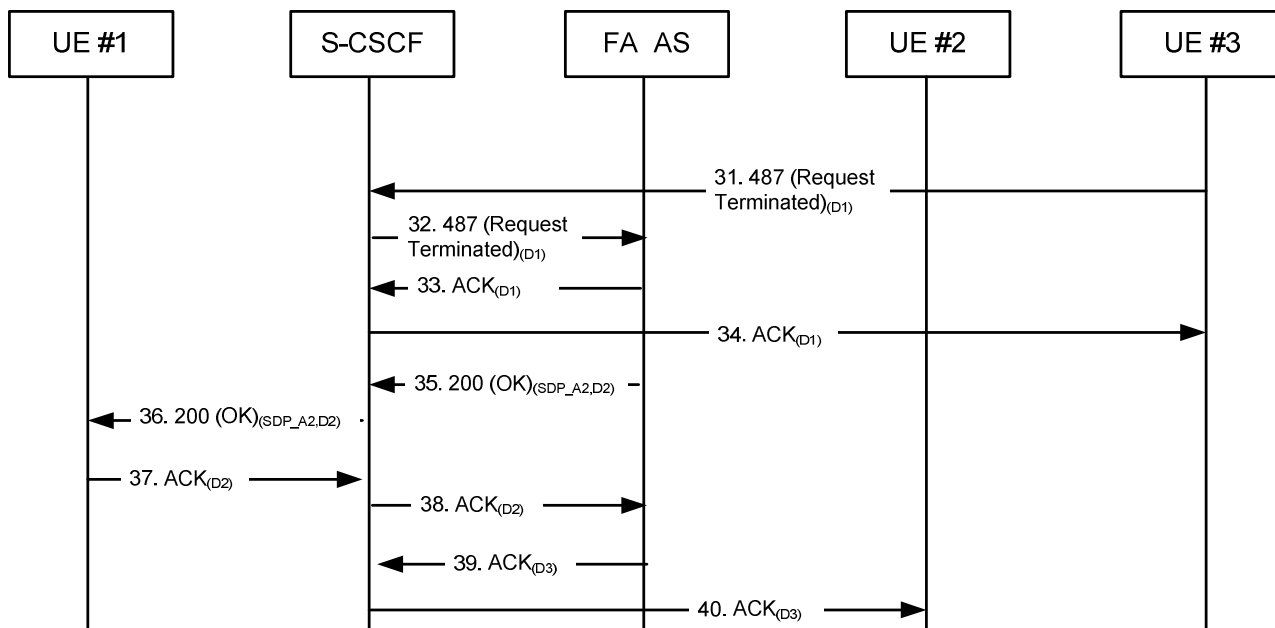

Figure A.3.2-2: FA, UE#3 does not have required resources available

1 INVITE request (UE#1 to S-CSCF) see example in table A.3.2-1

UE#1 sends a SIP INVITE request to the intermediate IM CN subsystem.

Table A.3.2-1: INVITE request (UE#1 to FA-AS)

```

INVITE tel:+1-212-555-2222 SIP/2.0
Via: SIP/2.0/UDP [5555::aaa:bbb:ccc:ddd]:1357;comp=sigcomp;branch=z9hG4bKnashds7
Max-Forwards: 70
Route: <sip:pcscf1.visited1.net:7531;lr;comp=sigcomp>, <sip:scscf1.home1.net;lr>
P-Preferred-Identity: "John Doe" <sip:user1_public1@home1.net>
P-Access-Network-Info: IEEE-802.11a
P-Preferred-Service: urn:urn-7:3gpp-service.ims.icsi.mmtel
Accept-Contact: *;+g.3gpp.icsi-ref="urn%3Aurn-7%3gpp-service.ims.icsi.mmtel"
Privacy: none
From: <sip:user1_public1@home1.net>;tag=171828
To: <tel:+1-212-555-2222>
Call-ID: cb03a0s09a2sdfgk490333
Cseq: 127 INVITE
Require: sec-agree
Supported: precondition, 100rel, gruu, 199
Proxy-Require: sec-agree
Security-Verify: ipsec-3gpp; q=0.1; alg= hmac-sha-1-96; spi-c=98765432; spi-s=87654321;
port-c=8642; port-s=7531
Contact: <sip:user1_public1@home1.net;gr=urn:uuid:f81d4fae-7dec-11d0-a765-
00a0c91e6bf6>;+g.3gpp.icsi-ref="urn%3Aurn-7%3gpp-service.ims.icsi.mmtel"
Allow: INVITE, ACK, CANCEL, BYE, PRACK, UPDATE, REFER, MESSAGE
Accept: application/sdp, application/3gpp-ims+xml
Content-Type: application/sdp
Content-Length: (...)

v=0
o=- 2987933615 2987933615 IN IP6 6666::aaa:bbb:ccc:ddd
s=-
c=IN IP6 6666::aaa:bbb:ccc:ddd
t=0 0
m=video 3400 RTP/AVP 98
a=tcap:1 RTP/AVPF
a=pcfg:1 t=1
b=AS:75
a=curr:qos local sendrecv
a=curr:qos remote none
a=des:qos mandatory local sendrecv
a=des:qos none remote sendrecv
a=rtpmap:98 H263
a=fmtp:98 profile-level-id=0
m=audio 3456 RTP/AVP 97 96
a=tcap:1 RTP/AVPF
a=pcfg:1 t=1
b=AS:25.4
a=curr:qos local sendrecv
a=curr:qos remote none
a=des:qos mandatory local sendrecv
a=des:qos none remote sendrecv
a=rtpmap:97 AMR
a=fmtp:97 mode-set=0,2,5,7; maxframes=2
a=rtpmap:96 telephone-event

```

Request-URI: The request URI is set to the Pilot Identity of the FA group.

Supported: The UE indicates support for preconditions, reliable provisional responses, gruu and the 199 provisional response.

SDP: The SDP offer (SDP_O) contains a set of codecs supported by UE#1 and desired by the calling user for this session. The local preconditions are indicated as fulfilled.

2 INVITE request (S-CSCF to FA-AS)

The S-CSCF forwards the SIP INVITE request to the FA-AS.

3-4 INVITE request (FA-AS to UE#3)

The Pilot Identity included in the Request-URI in the received INVITE request is mapped to the public user identities of the individual FA members in the FA group. The FA-AS forwards the INVITE request to the individual FA members in the FA group. The FA-AS forwards the INVITE request to UE#3, with the Request-URI set the public user identity which is an identity included in the FA group and registered from UE#3.

5-6180 (Ringing) provisional response (UE#3 to FA-AS) see example in table A.3.2-2

The called party is alerted. UE#3 sends a reliable SIP 180 (Ringing) provisional response for the INVITE request to the FA-AS.

Table A.3.4-2: 180 (Ringing) response (UE#3 to FA-AS)

```
SIP/2.0 180 Ringing
Via: SIP/2.0/UDP pcscf2.visited2.net:5088;comp=sigcomp;branch=z9hG4bK361k21.1, SIP/2.0/UDP
    scscf2.home2.net;branch=z9hG4bK764XC12.1, SIP/2.0/UDP
    faas.home2.net;branch=z9hG4bK764Q32.1, SIP/2.0/UDP
    scscf2.home2.net;branch=z9hG4bK764z87.1, SIP/2.0/UDP
    icscf2_s.home2.net;branch=z9hG4bK871y12.1, SIP/2.0/UDP
    scscf1.home1.net;branch=z9hG4bK332b23.1, SIP/2.0/UDP
    pcscf1.visited1.net;branch=z9hG4bK240f34.1, SIP/2.0/UDP
    [5555::aaa:bbb:ccc:ddd]:1357;comp=sigcomp;branch=z9hG4bKnashds7
Record-Route: <sip:pcscf2.visited2.net:5088;lr;comp=sigcomp>, <sip:scscf2.home2.net;lr>,
    <sip:scscf1.home1.net;lr>, <sip:pcscf1.visited1.net;lr>
From:
To: <tel:+1-212-555-1001>;tag=6322
Call-ID:
Cseq:
Require: 100rel, precondition
Allow: INVITE, ACK, CANCEL, BYE, PRACK, UPDATE, REFER, MESSAGE
RSeq: 9021
Contact: <sip:user3_public1@visited1.net;gr=urn:uuid:f81d4fae-7dec-11d0-a765-
    00a0c91er2d2>;+g.3gpp.icsi-ref="urn%3Aurn-7%3gpp-service.ims.icsi.mmtel"
Content-Type: application/sdp
Content-Length: (...)

v=0
o=- 2987933615 2987933615 IN IP6 6666::eee:fff:aaa:bbb
s=-
c=IN IP6 6666::eee:fff:aaa:bbb
t=0 0
m=video 3400 RTP/AVPF 98
a=acfg:1 t=1
b=AS:75
a=curr:qos local sendrecv
a=curr:qos remote sendrecv
a=des:qos mandatory local sendrecv
a=des:qos mandatory remote sendrecv
a=rtptime:98 H263
a=fmtp:98 profile-level-id=0
m=audio 3456 RTP/AVPF 97 96
a=acfg:1 t=1
b=AS:25.4
a=curr:qos local sendrecv
a=curr:qos remote sendrecv
a=des:qos mandatory local sendrecv
a=des:qos mandatory remote sendrecv
a=rtptime:97 AMR
a=fmtp:97 mode-set=0,2,5,7; maxframes
```

SDP: The SDP answer (SDP_A1) contains a set of codecs to be used for the session. The local preconditions are indicated as fulfilled.

7-8 PRACK request (FA-AS to UE#3)

FA-AS sends a SIP PRACK request, which acknowledges the SIP 180 (Ringing) provisional response, to UE##3.

9-10 200 (OK) response to PRACK (UE#3 to FA-AS)

UE#3 sends a SIP 200 (OK) response for the SIP PRACK request to FA-AS.

11-12 180 (Ringing) provisional response (FA-AS to UE#1)

The FA-AS sends a reliable SIP 180 (Ringing) provisional response to UE#1.

An early dialog (D2) is established between UE#1 and the FA-AS.

13-14 PRACK request (UE#1 to FA-AS)

UE#1 sends a SIP PRACK request, which acknowledges the SIP 180 (Ringing) provisional response, to the FA-AS.

15-16 200 (OK) response to PRACK (FA-AS to UE#1)

The FA-AS sends a SIP 200 (OK) response for the SIP PRACK request to UE#1.

17-18 INVITE request (FA-AS to UE#2)

The Pilot Identity included in the Request-URI in the received INVITE request is mapped to the public user identities of the individual FA members in the FA group. The FA-AS forwards the INVITE request to the individual FA members in the FA group. In parallel to forwarding the request to UE #3 (see step 3), the FA-AS forwards the request to UE#2, with the Request-URI set the public user identity which is an identity included in the FA group and registered from UE#2.

19-20 180 (Ringing) provisional response (UE#2 to FA-AS) see example in table A.3.2-2

The called party is alerted. UE#2 sends a reliable SIP 180 (Ringing) provisional response for the INVITE request to the FA-AS.

Table A.3.4-3: 180 (Ringing) response (UE#2 to FA-AS)

```
SIP/2.0 180 Ringing
Via: SIP/2.0/UDP pcscf2.visited2.net:5088;comp=sigcomp;branch=z9hG4bK361k21.1, SIP/2.0/UDP
scscf2.home2.net;branch=z9hG4bK764XC12.1, SIP/2.0/UDP
faas.home2.net;branch=z9hG4bK764Q32.1, SIP/2.0/UDP
scscf2.home2.net;branch=z9hG4bK764z87.1, SIP/2.0/UDP
icscf2_s.home2.net;branch=z9hG4bK871y12.1, SIP/2.0/UDP
scscf1.home1.net;branch=z9hG4bK332b23.1, SIP/2.0/UDP
pcscf1.visited1.net;branch=z9hG4bK240f34.1, SIP/2.0/UDP
[5555::aaa:bbb:ccc:ddd]:1357;comp=sigcomp;branch=z9hG4bKnashds7
Record-Route: <sip:pcscf2.visited2.net:5088;lr;comp=sigcomp>, <sip:scscf2.home2.net;lr>,
<sip:scscf1.home1.net;lr>, <sip:pcscf1.visited1.net;lr>
From:
To: <tel:+1-212-555-1002>;tag=4114
Call-ID:
Cseq:
Require: 100rel, precondition
Allow: INVITE, ACK, CANCEL, BYE, PRACK, UPDATE, REFER, MESSAGE
RSeq: 7187
Contact: <sip:user2_public1@visited1.net;gr=urn:uuid:f81d4fae-7dec-11d0-a765-
00a0c91ewxyz>;+g.3gpp.icsi-ref="urn%3Aurn-7%3gpp-service.ims.icsi.mmtel"
Content-Type: application/sdp
Content-Length: (...)

v=0
o=- 2987933615 2987933615 IN IP6 6666::eee:fff:aaa:ccc
s=-
c=IN IP6 6666::eee:fff:aaa:ccc
t=0 0
m=video 3400 RTP/AVPF 98
a=acfg:1 t=1
b=AS:75
a=curr:qos local sendrecv
a=curr:qos remote sendrecv
a=des:qos mandatory local sendrecv
a=des:qos mandatory remote sendrecv
a=rtptime:98 H263
a=fmtp:98 profile-level-id=0
m=audio 3456 RTP/AVPF 97 96
a=acfg:1 t=1
b=AS:25.4
a=curr:qos local sendrecv
a=curr:qos remote sendrecv
a=des:qos mandatory local sendrecv
a=des:qos mandatory remote sendrecv
a=rtptime:97 AMR
a=fmtp:97 mode-set=0,2,5,7; maxframes
```

SDP: The SDP answer (SDP_A2) contains a set of codecs to be used for the session. The local preconditions are indicated as fulfilled.

21-22 PRACK request (FA-AS to UE#2)

FA-AS sends a SIP PRACK request, which acknowledges the SIP 180 (Ringing) provisional response, to UE#2.

23-24 200 (OK) response to PRACK (UE#2 to FA-AS)

UE#2 sends a SIP 200 (OK) response for the SIP PRACK request to FA-AS.

25-26 200 (OK) response to INVITE (UE#2 to FA-AS)

The called party answers the call. UE#2 sends a SIP 200 (OK) final response for the SIP INVITE request to the FA-AS.

27-28 CANCEL request (FA-AS to UE#3)

FA-AS sends a SIP CANCEL request, to cancel early dialog D1, to UE#3.

29-30 200 (OK) response to CANCEL (UE#3 to FA-AS)

UE#3 sends a SIP 200 (OK) response for the SIP PRACK request to FA-AS.

31-32 487 (Request Terminated) (UE#3 to FA-AS)

UE#3 sends a SIP 487 (Request Terminated), to cancel early dialog D1, to FA-AS.

33-34 ACK request to CANCEL (FA-AS to FA-UE#3)

FA-AS sends a SIP ACK request, which acknowledges the 200 (OK) to CANCEL, to UE#3.

35-36 200 (OK) response to INVITE (FA-AS to UE#1)

In parallel to sending the CANCEL request to UE#3 (see step 27), the FA-AS sends a SIP 200 (OK) response to UE#1. The response contains SDP answer (SDP_A2).

37-38 ACK request (UE#1 to FA-AS)

UE#1 sends a SIP ACK request, which acknowledges the SIP 200 (OK) final response, to FA-AS.

39-40 ACK request (FA-AS to UE#2)

FA-AS sends a SIP ACK request, which acknowledges the SIP 200 (OK) final response, to UE#2.

Annex B (informative): Example of filter criteria

This annex provides an example of a filter criterion that triggers SIP requests that are subject to initial filter criteria evaluation.

When the initial request matches the conditions of the next unexecuted IFC rule for the served user which points to the FA service and the, the communication is forwarded to the AS.

An example of an Initial Filter Criteria (IFC) Trigger Point configurations under the assumption that the FA service is a standalone service that can be invoked by a very specific triggerpoint active at the destination S-CSCF:

- (Method="INVITE" AND Header="Request-URI").

NOTE 1: The coding of the Initial Filter Criteria is described in 3GPP TS 29.228 [7].

Annex C (informative): Change history

Change history							
Date	TSG #	TSG Doc.	CR	Rev	Subject/Comment	Old	New
2008-01					Rapporteurs input framework document	0.0.0	0.0.1
2008-04					Implementation of CRs agreed at CT1#52 as follows: C1-081362, C1-081363, C1-081364, C1-081365	0.0.1	0.1.0
2008-04					Miscellaneous editorial corrections	0.1.0	0.1.1
2008-05					Implemented C1-082034, C1-082035		0.2.0
2008-07					Implemented C1-082448, C1-082662 from CT1#54		0.3.0
2008-08					Implemented C1-082959, C1-083207, C1-083371, C1-083372 from CT1#55		0.4.0
2008-09					Version 1.0.0 created for presentation to TSG CT#41 for information	0.4.0	1.0.0
2008-11					Implemented the following CRs after CT1#56: C1-085095, C1-085096, C1-085097, C1-085273, C1-085274, C1-085276, C1-085457		1.1.0
2008-11					Version 2.0.0 created for presentation to TSG CT#42 for approval	1.1.0	2.0.0
2008-12	CT-42				Version 8.0.0 created after approval in CT#42	2.0.0	8.0.0
2009-03	CT-43	CP-090121	0001		Correction of URN-value for Service Identifiers	8.0.0	8.1.0
2009-03	CT-43	CP-090143	0002	1	Service configuration XML schema for IMS Flexible Alerting	8.0.0	8.1.0
2009-03	CT-43	CP-090143	0003		Flow updates	8.0.0	8.1.0
2009-12	CT-46	CP-090910	0004	1	Correction of FA XML schema - activation	8.1.0	8.2.0
2009-12	CT-46	CP-090910	0005	1	Removal of editor's notes from 24.239	8.1.0	8.2.0
2009-12	CT-46				Upgrade to Rel-9	8.2.0	9.0.0
2011-03	CT-51				Upgrade to Rel-10	9.0.0	10.0.0
2012-09	CT-57				Upgrade to Rel-11	10.0.0	11.0.0
2013-06	CT-60	CP-130265	0006	3	Flexible Alerting-Sequential mode	11.0.0	12.0.0
2015-12	CT-70				Upgrade to Rel-13	12.0.0	13.0.0

Change history							
Date	Meeting	TDoc	CR	Rev	Cat	Subject/Comment	New version
2017-03	CT75					Upgrade to Rel-14	14.0.0
2017-12	CT-78	CP-173071	0008	3	B	Flexible Alerting (FA) using IP Multimedia (IM) Core Network (CN) subsystem	15.0.0
2019-12	CT-86	CP-193111	0009	1	B	Adding interactions with "Multi-Device" and "Multi-Identity" services	16.0.0

History

Document history		
V16.0.0	November 2020	Publication