

ETSI TS 124 216 V7.1.0 (2007-06)

Technical Specification

Universal Mobile Telecommunications System (UMTS); Communication continuity Management Object (MO) (3GPP TS 24.216 version 7.1.0 Release 7)



Reference

DTS/TSGC-0124216v710

Keywords

UMTS

ETSI

650 Route des Lucioles
F-06921 Sophia Antipolis Cedex - FRANCE

Tel.: +33 4 92 94 42 00 Fax: +33 4 93 65 47 16

Siret N° 348 623 562 00017 - NAF 742 C
Association à but non lucratif enregistrée à la
Sous-Préfecture de Grasse (06) N° 7803/88

Important notice

Individual copies of the present document can be downloaded from:

<http://www.etsi.org>

The present document may be made available in more than one electronic version or in print. In any case of existing or perceived difference in contents between such versions, the reference version is the Portable Document Format (PDF). In case of dispute, the reference shall be the printing on ETSI printers of the PDF version kept on a specific network drive within ETSI Secretariat.

Users of the present document should be aware that the document may be subject to revision or change of status. Information on the current status of this and other ETSI documents is available at

<http://portal.etsi.org/tb/status/status.asp>

If you find errors in the present document, please send your comment to one of the following services:

http://portal.etsi.org/chaicor/ETSI_support.asp

Copyright Notification

No part may be reproduced except as authorized by written permission.
The copyright and the foregoing restriction extend to reproduction in all media.

© European Telecommunications Standards Institute 2007.
All rights reserved.

DECTTM, **PLUGTESTS**TM and **UMTS**TM are Trade Marks of ETSI registered for the benefit of its Members.
TIPHONTM and the **TIPHON logo** are Trade Marks currently being registered by ETSI for the benefit of its Members.
3GPPTM is a Trade Mark of ETSI registered for the benefit of its Members and of the 3GPP Organizational Partners.

Intellectual Property Rights

IPRs essential or potentially essential to the present document may have been declared to ETSI. The information pertaining to these essential IPRs, if any, is publicly available for **ETSI members and non-members**, and can be found in ETSI SR 000 314: *"Intellectual Property Rights (IPRs); Essential, or potentially Essential, IPRs notified to ETSI in respect of ETSI standards"*, which is available from the ETSI Secretariat. Latest updates are available on the ETSI Web server (<http://webapp.etsi.org/IPR/home.asp>).

Pursuant to the ETSI IPR Policy, no investigation, including IPR searches, has been carried out by ETSI. No guarantee can be given as to the existence of other IPRs not referenced in ETSI SR 000 314 (or the updates on the ETSI Web server) which are, or may be, or may become, essential to the present document.

Foreword

This Technical Specification (TS) has been produced by ETSI 3rd Generation Partnership Project (3GPP).

The present document may refer to technical specifications or reports using their 3GPP identities, UMTS identities or GSM identities. These should be interpreted as being references to the corresponding ETSI deliverables.

The cross reference between GSM, UMTS, 3GPP and ETSI identities can be found under <http://webapp.etsi.org/key/queryform.asp>.

Contents

Intellectual Property Rights	2
Foreword.....	2
Foreword.....	4
1 Scope	5
2 References	5
3 Definitions and abbreviations.....	5
3.1 Definitions	5
3.2 Abbreviations	5
4 Communication Continuity Management Object.....	6
5 Management Object parameters.....	6
5.1 General	6
5.2 Node: /<X>	6
5.3 /<X>/Name	7
5.4 /<X>/VDI/.....	7
5.5 /<X>/VDN/	7
5.6 /<X>/Preferred domain/	7
5.7 /<X>/Immediate DT/	8
5.8 /<X>/ DT CS-to-IM CN direction /	8
5.9 /<X>/ DT IM CN-to-CS direction /	8
5.10 /<X>/ DT in held_waiting calls/	8
5.11 /<X>/Ext/	9
Annex A (informative): Management Object DDF	10
Annex B (informative): Change history	14
History	15

Foreword

This Technical Specification has been produced by the 3rd Generation Partnership Project (3GPP).

The contents of the present document are subject to continuing work within the TSG and may change following formal TSG approval. Should the TSG modify the contents of the present document, it will be re-released by the TSG with an identifying change of release date and an increase in version number as follows:

Version x.y.z

where:

- x the first digit:
 - 1 presented to TSG for information;
 - 2 presented to TSG for approval;
 - 3 or greater indicates TSG approved document under change control.
- y the second digit is incremented for all changes of substance, i.e. technical enhancements, corrections, updates, etc.
- z the third digit is incremented when editorial only changes have been incorporated in the document.

1 Scope

This document defines the Communication Continuity Management Object. The management object is compatible with OMA Device Management protocol specifications, version 1.2 and upwards, and is defined using the OMA DM Device Description Framework as described in the Enabler Release Definition OMA-ERELED_DM-V1_2[4].

The Communication Continuity Management Object consists of relevant parameters that can be managed for Communication Continuity capabilities.

2 References

The following documents contain provisions which, through reference in this text, constitute provisions of the Communication Continuity Management Object document.

- References are either specific (identified by date of publication, edition number, version number, etc.) or non-specific.
- For a specific reference, subsequent revisions do not apply.
- For a non-specific reference, the latest version applies. In the case of a reference to a 3GPP document (including a GSM document), a non-specific reference implicitly refers to the latest version of that document *in the same Release as the present document*.

- [1] 3GPP TR 21.905: "Vocabulary for 3GPP Specifications".
- [2] 3GPP TS 23.003: "Numbering, addressing and identification".
- [3] 3GPP TS 24.206: "Voice call continuity between Circuit Switched (CS) and IP Multimedia Subsystem (IMS); Stage 3".
- [4] OMA-ERELED-DM-V1_2-20060602-C: "Enabler Release Definition for OMA Device Management, Candidate Version 1.2".

3 Definitions and abbreviations

3.1 Definitions

For the purposes of the present document, the terms and definitions given in 3GPP TR 21.905 [1] apply.

For the purposes of the present document, the following terms and definitions given in 3GPP TS 23.003 [2] apply:

VCC Domain Transfer Number (VDN)
VCC Domain Transfer URI (VDI)

3.2 Abbreviations

For the purposes of the present document, the following abbreviations apply:

CN	Core Network
DDF	Device Description Framework
DM	Device Management
DT	Domain Transfer
IMS	IP Multimedia core network Subsystem
IP	Internet Protocol
MO	Management Object
OMA	Open Mobile Alliance

SIP	Session Initiation Protocol
UE	User Equipment
VCC	Voice Call Continuity
VDI	VCC Domain Transfer URI
VDN	VCC Domain Transfer Number

4 Communication Continuity Management Object

The Communication Continuity Management Object is used to manage settings of the UE for communication continuation capabilities. The Management Object covers parameters for communication continuation related capabilities. The Management Object enables the management of the settings on behalf of the end user.

The Communication Continuity MO covers settings of the UE for the following capabilities:

- Voice Call Continuity (VCC) as specified in 3GPP TS 24.206 [3].

NOTE: The Communication Continuity MO can be expanded to cover settings of further communication continuity capabilities.

The Management Object Identifier is: urn:oma:mo:XXXX:1.0.

Editor's Note: The value urn:oma:mo:XXXX:1.0 needs to be replaced with the value registered for this MO by OMA.

Protocol compatibility: This MO is compatible with OMA DM 1.2.

The following nodes and leaf objects are possible under the Communication Continuity node:

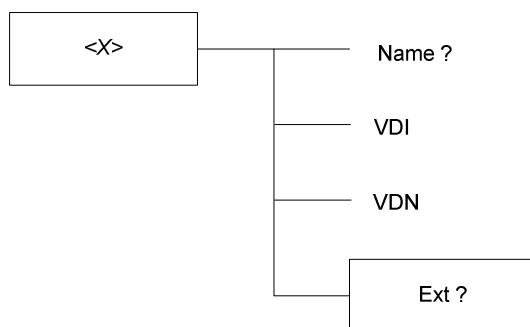

Figure 1: The Communication Continuity Object

5 Management Object parameters

5.1 General

This clause describes the parameters for the Communication Continuity Management Object.

5.2 Node: /<X>

This interior node acts as a placeholder for one or more accounts for a fixed node.

- Occurrence: OneOrMore
- Format: node
- Access Types: Get
- Values: N/A

The interior node is mandatory if the UE supports one or more Communication Continuity capabilities. Support for a UE is defined by the related roles as defined by the related communication continuity service, as listed in clause 4 of this specification.

NOTE: One node is normally used.

5.3 /<X>/Name

The Name leaf is a name for the Communication Continuity settings.

- Occurrence: ZeroOrOne
- Format: chr
- Access Types: Get
- Values: <User displayable name>

5.4 /<X>/VDI/

The VDI leaf is the VCC Transfer URI that the user includes in SIP INVITE requests to initiate domain transfer.

- Occurrence: One
- Format: chr
- Access Types: Get, Replace
- Values: < A VCC VDI >

The format of the VCC VDI is defined by 3GPP TS 23.003 [2].

EXAMPLE: sip:domain.xfer@dtf1.home1.net

5.5 /<X>/VDN/

The VDN leaf is the VCC Transfer Number that the user includes in a circuit switched call setup to initiate domain transfer.

- Occurrence: One
- Format: chr
- Access Types: Get, Replace
- Values: < A VCC VDN >

The format of the VCC VDN is defined by 3GPP TS 23.003 [2].

EXAMPLE: +12125555555

5.6 /<X>/Preferred domain/

The Preferred domain leaf represents the operator's preferred domain for UE originated calls/sessions.

- Occurrence: One
- 1) Format: chr
- Access Types: Get, Replace
- Values: 0, 1, 2, 3
 - 0 – Indicates the preference for CS domain.
 - 1 – Indicates the preference for IM CN subsystem.
 - 2 – Indicates the preference for CS domain only.
 - 3 – Indicates the preference for IM CN subsystem only.

5.7 /<X>/Immediate DT/

The Immediate Domain Transfer leaf indicates whether to initiate a VCC domain transfer immediately to the operator's preferred domain when that domain becomes available. This operator policy only affects ongoing sessions.

- Occurrence: One
- 2) Format: bool
- Access Types: Get, Replace
- Values: 0, 1
 - 0 – Indicates the preference to not initiate domain transfer immediately to the preferred domain when that domain becomes available.
 - 1 – Indicates the preference to initiate domain transfer immediately to the preferred domain when that domain becomes available.

NOTE 1: If the Immediate Domain Transfer operator policy indicates that the domain transfer is not immediately required then it is up to the VCC UE to decide when to perform the domain transfer if the preferred domain is available.

5.8 /<X>/ DT CS-to-IM CN direction /

The Domain Transfer CS-to-IM CN direction leaf indicates if a VCC domain transfer from CS domain to IMS is restricted.

- Occurrence: One
- 3) Format: bool
- Access Types: Get, Replace
- Values: 0, 1
 - 0 – Indicates that the network operator prefers the domain transfer in the CS to IM CN subsystem direction can occur.
 - 1 – Indicates that the network operator prefers the domain transfer in the CS to IM CN subsystem direction cannot occur.

5.9 /<X>/ DT IM CN-to-CS direction /

The Domain Transfer IM CN-to-CS direction leaf indicates if a VCC domain transfer from IM CN subsystem to CS domain is restricted.

- Occurrence: One
- 4) Format: bool
- Access Types: Get, Replace
- Values: 0, 1
 - 0 – Indicates that the network operator prefers the domain transfer in the IM CN subsystem to CS direction can occur.
 - 1 – Indicates that the network operator prefers the domain transfer in the IM CN subsystem to CS direction cannot occur.

5.10 /<X>/ DT in held_waiting calls/

The Domain Transfer in held_waiting calls leaf indicates whether a VCC domain transfer is restricted when the VCC UE is engaged in an active and a held/waiting call/session on the transferring-out domain (the restriction doesn't apply in the case the VCC UE is losing coverage in the transferring-out domain). If the operator policy requires restriction in the Domain Transfer in held_waiting calls then the VCC UE should not consider other operator policy for the domain transfer.

- Occurrence: One
- 5) Format: bool

- Access Types: Get, Replace
- Values: 0, 1
 - 0 – Indicates that the network operator prefers the domain transfer can occur when the VCC UE is engaged in an active and a held/waiting call/session on the transferring-out domain.
 - 1 – Indicates that the network operator prefers the domain transfer cannot occur when the VCC UE is engaged in an active and a held/waiting call/session on the transferring-out domain.

5.11 /<X>/Ext/

The Ext is an interior node for where the vendor specific information about the Communication Continuity MO is being placed (vendor meaning application vendor, device vendor etc.). Usually the vendor extension is identified by vendor specific name under the ext node. The tree structure under the vendor identified is not defined and can therefore include one or more un-standardized sub-trees.

- Occurrence: ZeroOrOne
- Format: node
- Access Types: Get, Replace
- Values: N/A

Annex A (informative): Management Object DDF

This DDF is the standardized minimal set. A vendor can define it's own DDF for the complete device. This DDF can include more features than this minimal standardized version.

```
<?xml version="1.0" encoding="UTF-8"?>
<!DOCTYPE MgmtTree PUBLIC "-//OMA//DTD SYNCML-DMDDF 1.2//EN"
http://www.openmobilealliance.org/tech/DTD/OMA-SyncML-DMDDF-1_2.dtd>
<MgmtTree>
  <VerDTD>1.2</VerDTD>
  <Man--The device manufacturer--</Man>
  <Mod--The device model--</Mod>
  <Node>
    <NodeName>Communication_Continuity</NodeName>
    <DFProperties>
      <AccessType>
        <Get/>
      </AccessType>
      <Description>Communication Continuity settings</Description>
      <DFFormat>
        <node/>
      </DFFormat>
      <Occurrence>
        <OneOrMore/>
      </Occurrence>
      <DFTitle>The Communication Continuity Management Object.</DFTitle>
      <DFType>
        <DDFName/>
      </DFType>
    </DFProperties>
  <Node>
    <NodeName>Name</NodeName>
    <DFProperties>
      <AccessType>
        <Get/>
      </AccessType>
      <DFFormat>
        <chr/>
      </DFFormat>
      <Occurrence>
        <ZeroOrOne/>
      </Occurrence>
      <DFTitle>User displayable name for the node.</DFTitle>
      <DFType>
        <MIME>text/plain</MIME>
      </DFType>
    </DFProperties>
  </Node>
  <Node>
    <NodeName>VDI</NodeName>
    <DFProperties>
      <AccessType>
        <Get/>
        <Replace/>
      </AccessType>
      <DFFormat>

```

```

    <chr/>
  </DFFormat>
  <Occurrence>
    <One/>
  </Occurrence>
  <DFTitle>The VCC Transfer URI.</DFTitle>
  <DFType>
    <DDFName/>
  </DFType>
</DFProperties>
</Node>

<Node>
  <NodeName>VDN</NodeName>
  <DFProperties>
    <AccessType>
      <Get/>
      <Replace/>
    </AccessType>
    <DFFormat>
      <chr/>
    </DFFormat>
    <Occurrence>
      <One/>
    </Occurrence>
    <DFTitle>The VCC Transfer Number.</DFTitle>
    <DFType>
      <DDFName/>
    </DFType>
  </DFProperties>
</Node>

<Node>
  <NodeName> Preferred domain </NodeName>
  <DFProperties>
    <AccessType>
      <Get/>
      <Replace/>
    </AccessType>
    <DFFormat>
      < chr/>
    </DFFormat>
    <Occurrence>
      <One/>
    </Occurrence>
    <DFTitle> Preferred domain </DFTitle>
    <DFType>
      <MIME>text/plain</MIME>
    </DFType>
  </DFProperties>
</Node>

<Node>
  <NodeName> Immediate DT </NodeName>
  <DFProperties>
    <AccessType>
      <Get/>
      <Replace/>
    </AccessType>
    <DFFormat>
      <bool/>
    </DFFormat>

```

```

    <Occurrence>
      <One/>
    </Occurrence>
    <DFTitle> Immediate DT </DFTitle>
    <DFType>
      <MIME>text/plain</MIME>
    </DFType>
  </DFProperties>
</Node>

<Node>
  <NodeName> DT CS-to-IM CN direction </NodeName>
  <DFProperties>
    <AccessType>
      <Get/>
      <Replace/>
    </AccessType>
    <DFFormat>
      <bool/>
    </DFFormat>
    <Occurrence>
      <One/>
    </Occurrence>
    <DFTitle> DT CS-to-IM CN direction </DFTitle>
    <DFType>
      <MIME>text/plain</MIME>
    </DFType>
  </DFProperties>
</Node>

<Node>
  <NodeName> DT IM CN-to-CS direction </NodeName>
  <DFProperties>
    <AccessType>
      <Get/>
      <Replace/>
    </AccessType>
    <DFFormat>
      <bool/>
    </DFFormat>
    <Occurrence>
      <One/>
    </Occurrence>
    <DFTitle> DT IM CN-to-CS direction </DFTitle>
    <DFType>
      <MIME>text/plain</MIME>
    </DFType>
  </DFProperties>
</Node>

<Node>
  <NodeName> DT in held_waiting calls </NodeName>
  <DFProperties>
    <AccessType>
      <Get/>
      <Replace/>
    </AccessType>
    <DFFormat>
      <bool/>
    </DFFormat>
    <Occurrence>
      <One/>
    </Occurrence>
  </DFProperties>
</Node>

```

```
        </Occurrence>
        <DFTitle> DT in held_waiting calls </DFTitle>
        <DFType>
          <MIME>text/plain</MIME>
        </DFType>
      </DFProperties>
    </Node>

    <Node>
      <NodeName>Ext</NodeName>
      <!-- The Extension node starts here. -->
      <DFProperties>
        <AccessType>
          <Get/>
          <Replace/>
        </AccessType>
        <DFFormat>
          <node/>
        </DFFormat>
        <Occurrence>
          <ZeroOrOne/>
        </Occurrence>
        <DFTitle>A collection of all Extension objects.</DFTitle>
        <DFType>
          <DDFName/>
        </DFType>
      </DFProperties>
    </Node>

  </Node>
</MgmtTree>
```

Annex B (informative): Change history

Change history								
Date	TSG #	TSG Doc.	CR	Rev	Subject/Comment	Old	New	WG doc
2007-01					Version 0.0.0: Preliminary proposal		0.0.0	
2007-01					Version 0.0.1: Version after CT1#45	0.0.0	0.0.1	
2007-02					Version 2.0.0: Editor introduced TS number, sent to TSG CT 35 for information and approval	0.0.1	1.0.0	
2007-03					Version 1.0.0 approved by CT#35 in CP-070128 and version 7.0.0 created by MCC	1.0.0	7.0.0	
2007-06	CT#36	CP-070377	0001	1	Corrections to parameters in 24.216	7.0.0	7.1.0	C1-070942
2007-06	CT#36	CP-070377	0002	1	Introduction of operator policies	7.0.0	7.1.0	C1-071341

History

Document history		
V7.1.0	June 2007	Publication