

ETSI TS 124 167 V6.7.0 (2009-03)

Technical Specification

**Universal Mobile Telecommunications System (UMTS);
LTE;
3GPP IMS Management Object (MO);
Stage 3
(3GPP TS 24.167 version 6.7.0 Release 6)**



Reference

RTS/TSGC-0124167v670

Keywords

UMTS

ETSI

650 Route des Lucioles
F-06921 Sophia Antipolis Cedex - FRANCE

Tel.: +33 4 92 94 42 00 Fax: +33 4 93 65 47 16

Siret N° 348 623 562 00017 - NAF 742 C
Association à but non lucratif enregistrée à la
Sous-Préfecture de Grasse (06) N° 7803/88

Important notice

Individual copies of the present document can be downloaded from:

<http://www.etsi.org>

The present document may be made available in more than one electronic version or in print. In any case of existing or perceived difference in contents between such versions, the reference version is the Portable Document Format (PDF). In case of dispute, the reference shall be the printing on ETSI printers of the PDF version kept on a specific network drive within ETSI Secretariat.

Users of the present document should be aware that the document may be subject to revision or change of status. Information on the current status of this and other ETSI documents is available at

<http://portal.etsi.org/tb/status/status.asp>

If you find errors in the present document, please send your comment to one of the following services:

http://portal.etsi.org/chaicor/ETSI_support.asp

Copyright Notification

No part may be reproduced except as authorized by written permission.
The copyright and the foregoing restriction extend to reproduction in all media.

© European Telecommunications Standards Institute 2009.
All rights reserved.

DECTTM, **PLUGTESTS**TM, **UMTS**TM, **TIPHON**TM, the TIPHON logo and the ETSI logo are Trade Marks of ETSI registered for the benefit of its Members.

3GPPTM is a Trade Mark of ETSI registered for the benefit of its Members and of the 3GPP Organizational Partners.

LTETM is a Trade Mark of ETSI currently being registered

for the benefit of its Members and of the 3GPP Organizational Partners.

GSM[®] and the GSM logo are Trade Marks registered and owned by the GSM Association.

Intellectual Property Rights

IPRs essential or potentially essential to the present document may have been declared to ETSI. The information pertaining to these essential IPRs, if any, is publicly available for **ETSI members and non-members**, and can be found in ETSI SR 000 314: *"Intellectual Property Rights (IPRs); Essential, or potentially Essential, IPRs notified to ETSI in respect of ETSI standards"*, which is available from the ETSI Secretariat. Latest updates are available on the ETSI Web server (<http://webapp.etsi.org/IPR/home.asp>).

Pursuant to the ETSI IPR Policy, no investigation, including IPR searches, has been carried out by ETSI. No guarantee can be given as to the existence of other IPRs not referenced in ETSI SR 000 314 (or the updates on the ETSI Web server) which are, or may be, or may become, essential to the present document.

Foreword

This Technical Specification (TS) has been produced by ETSI 3rd Generation Partnership Project (3GPP).

The present document may refer to technical specifications or reports using their 3GPP identities, UMTS identities or GSM identities. These should be interpreted as being references to the corresponding ETSI deliverables.

The cross reference between GSM, UMTS, 3GPP and ETSI identities can be found under <http://webapp.etsi.org/key/queryform.asp>.

Contents

Intellectual Property Rights	2
Foreword.....	2
Foreword.....	4
1 Scope	5
2 References	5
3 Definitions and abbreviations.....	6
3.1 Definitions	6
3.2 Abbreviations	6
4 3GPP IMS Management Object.....	6
5 Management Object parameters.....	7
5.1 General	7
5.2 Node: /<X>	7
5.3 /<X>/AppID.....	8
5.4 /<X>/Name	8
5.5 /<X>/ConRefs/.....	8
5.6 /<X>/ConRefs/<X>	8
5.7 /<X>/ConRefs/<X>/ConRef.....	8
5.8 /<X>/PDP_ContextOperPref	9
5.9 /<X>/P-CSCF_Address.....	9
5.10 /<X>/Timer_T1.....	9
5.11 /<X>/Timer_T2.....	9
5.12 /<X>/Timer_T4.....	10
5.13 /<X>/Private_user_identity.....	10
5.14 /<X>/Public_user_identity_List/.....	10
5.15 /<X>/Public_user_identity_List/<X>.....	11
5.16 /<X>/Public_user_identity_List/<X>/Public_user_identity.....	11
5.17 /<X>/Home_network_domain_name.....	11
5.18 /<X>/Ext/.....	11
Annex A (informative): Management Object DDF	13
Annex B (informative): 3GPP IMS Client Provisioning Application Characteristics (CP AC)	20
B.1 General	20
B.2 Definition of the 3GPP IMS Client Provisioning Application Characteristics	20
Annex C (informative): Change history	23
History	24

Foreword

This Technical Specification has been produced by the 3rd Generation Partnership Project (3GPP).

The contents of the present document are subject to continuing work within the TSG and may change following formal TSG approval. Should the TSG modify the contents of the present document, it will be re-released by the TSG with an identifying change of release date and an increase in version number as follows:

Version x.y.z

where:

- x the first digit:
 - 1 presented to TSG for information;
 - 2 presented to TSG for approval;
 - 3 or greater indicates TSG approved document under change control.
- y the second digit is incremented for all changes of substance, i.e. technical enhancements, corrections, updates, etc.
- z the third digit is incremented when editorial only changes have been incorporated in the document.

1 Scope

This document defines a mobile device 3GPP IMS Management Object. The management object is compatible with OMA Device Management protocol specifications, version 1.1.2 and upwards, and is defined using the OMA DM Device Description Framework as described in the Enabler Release Definition OMA-ERELED-SyncML_DM-V1_1_2-20031209-A [9].

The 3GPP IMS Management Object consists of relevant parameters that can be managed for the IM CN Subsystem. This includes the basic framework defined in 3GPP TS 23.228 [4] and 3GPP TS 24.229 [5], and early IMS as defined in 3GPP TS 23.221 [3].

The IMS Management Object defines a repository of data into the ME including parameters that are provisioned from the ISIM application (i.e. 3GPP TS 31.103 [11]) or, after derivation, from the USIM application (i.e. 3GPP TS 31.102 [10]).

If the procedures for OMA Device Management is not supported by an implementation, the OMA Client Provisioning can be used as a fallback. Annex B of this document defines the 3GPP IMS Client Provisioning Application Characteristics as described in the Enabler Release Definition OMA-WAP-ProvCont-V1_1-20050428-C [13].

2 References

The following documents contain provisions which, through reference in this text, constitute provisions of the 3GPP IMS Management Object document.

- References are either specific (identified by date of publication, edition number, version number, etc.) or non-specific.
- For a specific reference, subsequent revisions do not apply.
- For a non-specific reference, the latest version applies. In the case of a reference to a 3GPP document (including a GSM document), a non-specific reference implicitly refers to the latest version of that document *in the same Release as the present document*.

- [1] 3GPP TR 21.905: "Vocabulary for 3GPP Specifications".
- [2] 3GPP TS 23.003: "Numbering, addressing and identification".
- [3] 3GPP TS 23.221: "Architectural requirements".
- [4] 3GPP TS 23.228: "IP Multimedia Subsystem (IMS); Stage 2".
- [5] 3GPP TS 24.229: "Internet Protocol (IP) multimedia call control protocol based on Session Initiation Protocol (SIP) and Session Description Protocol (SDP); Stage 3".
- [6] Void.
- [7] Void.
- [8] RFC 1123: "Requirements for Internet Hosts -- Application and Support".
- [9] OMA-ERELED-SyncML_DM-V1_1_2-20031209-A: "Enabler Release Definition for OMA Device Management (based on SyncML DM), Version 1.1.2".
- [10] 3GPP TS 31.102: "Characteristics of the USIM application".
- [11] 3GPP TS 31.103: "Characteristics of the IP Multimedia Services Identity Module; (ISIM) Application".
- [12] OMA-ERELED-DM-V1_2-20070209-A : "Enabler Release Definition for OMA Device Management, Version 1.2".

- [13] OMA-WAP-ProvCont-V1_1-20050428-C: "Enabler Release Definition for Client Provisioning, Version 1.1".

3 Definitions and abbreviations

3.1 Definitions

For the purposes of the present document, the terms and definitions given in 3GPP TR 21.905 [1] apply.

3.2 Abbreviations

For the purposes of the present document, the following abbreviations apply:

AC	Application Characteristics
CN	Core Network
CP	Client Provisioning
CSCF	Call Session Control Function
DDF	Device Description Framework
DM	Device Management
IMS	IP Multimedia core network Subsystem
IP	Internet Protocol
ISIM	IM Services Identity Module
MO	Management Object
OMA	Open Mobile Alliance
P-CSCF	Proxy – CSCF
PDP	Packet Data Protocol
SIP	Session Initiation Protocol
UE	User Equipment
USIM	Universal Subscriber Identity Module

4 3GPP IMS Management Object

The 3GPP IMS Management Object is used to manage settings of the UE for IM CN Subsystem protocols. The Management Object covers generic parameters for the IM CN subsystem. The Management Object enables the management of the settings on behalf of the end user.

The Management Object Identifier is: org.3gpp/1.0/SIPCore.

Protocol compatibility: This MO is compatible with OMA DM 1.1.2.

The following nodes and leaf objects are possible under the 3GPP_IMS node:

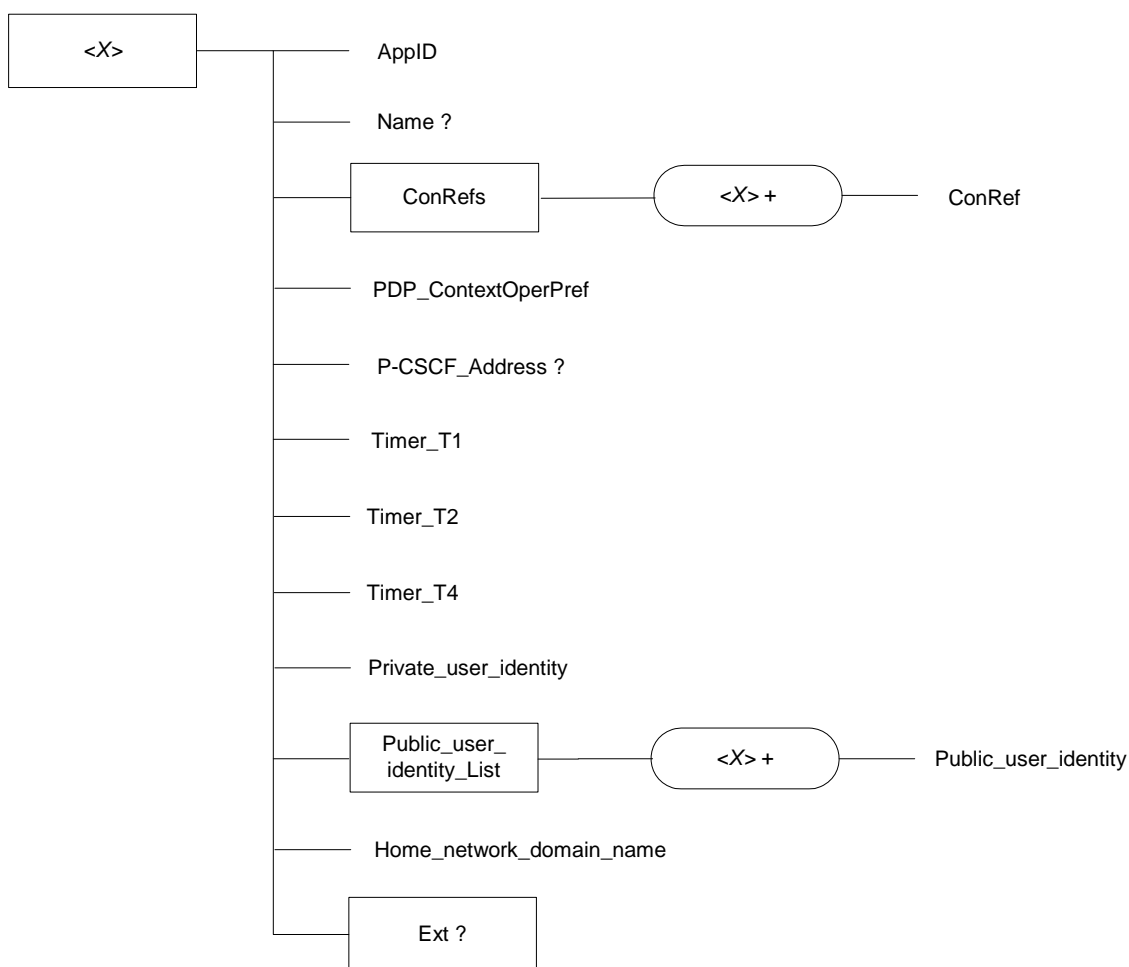

Figure 1: The 3GPP IMS Management Object

5 Management Object parameters

5.1 General

This clause describes the parameters for the 3GPP IMS Management Object.

5.2 Node: /<X>

This interior node acts as a placeholder for one or more accounts for a fixed node.

- Occurrence: OneOrMore
- Format: node
- Access Types: Get
- Values: N/A

The interior node is mandatory if the UE supports the IM CN Subsystem. Support for a UE is defined by the user agent role as defined in 3GPP TS 24.229 [5].

NOTE: One node is normally used. More nodes are only used in case the terminal supports multiple UICCs.

5.3 /<X>/AppID

The AppID identifies the type of the application service available at the described application service access point. The value is globally unique.

- Occurrence: One
- Format: chr
- Access Types: Get
- Value: <ap2001>

NOTE: The value of the 3GPP_IMS/AppID is determined by OMA.

5.4 /<X>/Name

The Name leaf is a name for the 3GPP_IMS settings.

- Occurrence: ZeroOrOne
- Format: chr
- Access Types: Get
- Values: <User displayable name>

5.5 /<X>/ConRefs/

The ConRefs interior node is used to allow a reference to a list of network access point objects.

- Occurrence: One
- Format: node
- Access Types: Get
- Values: N/A

5.6 /<X>/ConRefs/<X>

This run-time node acts as a placeholder for one or more network access point objects.

- Occurrence: OneOrMore
- Format: node
- Access Types: Get
- Values: N/A

5.7 /<X>/ConRefs/<X>/ConRef

The ConRef leaf represents one or more network access point objects.

- Occurrence: One
- Format: chr

- Access Types: Get, Replace
- Values: <A network access point object>

5.8 /<X>/PDP_ContextOperPref

The PDP_ContextOperPref leaf indicates an operator's preference to have a dedicated PDP context for SIP signalling.

- Occurrence: One
- Format: bool
- Access Types: Get, Replace
- Values: 0, 1

0 – Indicates that the operator has no preference for a dedicated PDP context for SIP signalling.

1 – Indicates that the operator has preference for a dedicated PDP context for SIP signalling.

The PDP_ContextOperPref leaf indicates a preference only. 3GPP TS 24.229 [5] describes the normative options and the procedures for establishment of a dedicated PDP context for SIP signalling.

5.9 /<X>/P-CSCF_Address

The P-CSCF_Address leaf defines an FQDN or an IPv4 address to an IPv4 P-CSCF.

- Occurrence: ZeroOrOne
- Format: chr
- Access Types: Get, Replace
- Values: <A fully qualified domain name> or IPv4 address>

The P-CSCF_Address leaf shall only be used in early IMS implementations as described in 3GPP TS 23.221 [3].

The FQDN, or host name as defined by RFC 1123 [8], is represented as character-labels with dots as delimiters.

EXAMPLE: pcscf.operator.com

5.10 /<X>/Timer_T1

The Timer_T1 leaf defines the SIP timer T1 – the RTT estimate.

- Occurrence: One
- Format: int
- Access Types: Get, Replace
- Values: <The round trip time>

The Timer_T1 leaf is an estimate for the round trip time in the system (UE – P-CSCF). The timer value shall be given in milliseconds. The default value is recommended in 3GPP TS 24.229 [5]. The Timer_T1 is a 32 bits unsigned integer.

EXAMPLE: 2000 (milliseconds)

5.11 /<X>/Timer_T2

The Timer_T2 leaf defines the SIP timer T2 – the maximum retransmit interval for non-INVITE requests and INVITE responses.

- Occurrence: One
- Format: int
- Access Types: Get, Replace
- Values: <The maximum retransmit interval for non-INVITE requests and INVITE responses>

The Timer_T2 leaf is an estimate for the maximum retransmit interval for non-INVITE requests and INVITE responses. The timer value shall be given in milliseconds. The default value is recommended in 3GPP TS 24.229 [5]. The Timer_T2 is a 32 bits unsigned integer.

EXAMPLE: 16000 (milliseconds)

5.12 /<X>/Timer_T4

The Timer_T4 leaf defines the SIP timer T4 – the maximum duration a message will remain in the network.

- Occurrence: One
- Format: chr
- Access Types: Get, Replace
- Values: <The maximum duration a message will remain in the network>

The Timer_T4 leaf is an estimate for the maximum duration a message will remain in the network. The timer value shall be given in milliseconds. The default value is recommended in 3GPP TS 24.229 [5]. The Timer_T4 is a 32 bits unsigned integer.

EXAMPLE: 17000 (milliseconds)

5.13 /<X>/Private_user_identity

The Private_user_identity leaf represents the private user identity.

- Occurrence: One
- Format: chr
- Access Types: Get
- Values: <A private user identity>

NOTE: The Private_user_identity leaf value is populated by the UE using the procedures to obtain the private user identity specified in 3GPP TS 24.229 [5].

The format of the private user identity is defined by 3GPP TS 23.003 [2].

EXAMPLE: 23415099999999@ims.mnc015.mcc234.3gppnetwork.org

5.14 /<X>/Public_user_identity_List/

The Public_user_identity_List interior node is used to allow a reference to a list of public user identities.

- Occurrence: One
- Format: node
- Access Types: Get
- Values: N/A

5.15 /<X>/Public_user_identity_List/<X>

This run-time node acts as a placeholder for one or more public user identities.

- Occurrence: OneOrMore
- Format: node
- Access Types: Get
- Values: N/A

5.16 /<X>/Public_user_identity_List/<X>/Public_user_identity

The Public_user_identity leaf represents one or more public user identities.

- Occurrence: One
- Format: chr
- Access Types: Get
- Values: <A public user identity>

NOTE: The Public_user_identity leaf value is populated by the UE using the procedures to obtain the public user identity specified in 3GPP TS 24.229 [5].

The temporary public user identity if derived is populated and stored as the topmost element in the Public_user_identity_List as specified in 3GPP TS 24.229 [5].

The format of the public user identity is defined by 3GPP TS 23.003 [2].

EXAMPLE: sip: 23415099999999@ims.mnc015.mcc234.3gppnetwork.org

5.17 /<X>/Home_network_domain_name

The Home_network_domain_name leaf indicates the operator's home network domain.

- Occurrence: One
- Format: chr
- Access Types: Get
- Values: <The home network domain name>

NOTE: The Home_network_domain_name leaf value is populated by the UE using the procedures to obtain the home network domain name specified in 3GPP TS 24.229 [5].

The format of the home network domain name is defined by 3GPP TS 23.003 [2].

EXAMPLE: ims.mnc015.mcc234.3gppnetwork.org

5.18 /<X>/Ext/

The Ext is an interior node for where the vendor specific information about the 3GPP-IMS MO is being placed (vendor meaning application vendor, device vendor etc.). Usually the vendor extension is identified by vendor specific name under the ext node. The tree structure under the vendor identified is not defined and can therefore include one or more un-standardized sub-trees.

- Occurrence: ZeroOrOne
- Format: node

- Access Types: Get
- Values: N/A

Annex A (informative): Management Object DDF

This DDF is the standardized minimal set. A vendor can define its own DDF for the complete device. This DDF can include more features than this minimal standardized version.

```

<?xml version="1.0" encoding="UTF-8"?>
<!DOCTYPE MgmtTree PUBLIC "-//OMA//DTD SYNCML-DMDDF 1.1.2//EN"
"http://www.openmobilealliance.org/Tech/DTD/OMA-SyncML-DMDDFDTD-V1_1_2-20030508-D.dtd"
<MgmtTree>
  <VerDTD>1.1.2</VerDTD>
  <Man--The device manufacturer--</Man>
  <Mod--The device model--</Mod>
  <Node>
    <NodeName>3GPP_IMS</NodeName>
    <DFProperties>
      <AccessType>
        <Get/>
      </AccessType>
      <Description>3GPP IMS settings</Description>
      <DFFormat>
        <node/>
      </DFFormat>
      <Occurrence>
        <OneOrMore/>
      </Occurrence>
      <Scope>
        <Permanent/>
      </Scope>
      <DFTitle>The 3GPP IMS Management Object.</DFTitle>
      <DFType>
        <DDFName/>
      </DFType>
    </DFProperties>
  </Node>
  <Node>
    <NodeName>AppID</NodeName>
    <DFProperties>
      <AccessType>
        <Get/>
      </AccessType>
      <DFFormat>
        <chr/>
      </DFFormat>
      <Occurrence>
        <One/>
      </Occurrence>
      <Scope>
        <Permanent/>
      </Scope>
      <DFTitle>The Application ID.</DFTitle>
      <DFType>
        <MIME>text/plain</MIME>
      </DFType>
    </DFProperties>
  </Node>
  <Node>
    <NodeName>Name</NodeName>
  
```

```

<DFProperties>
  <AccessType>
    <Get/>
  </AccessType>
  <DFFormat>
    <chr/>
  </DFFormat>
  <Occurrence>
    <ZeroOrOne/>
  </Occurrence>
  <Scope>
    <Dynamic/>
  </Scope>
  <DFTitle>User displayable name for the node.</DFTitle>
  <DFType>
    <MIME>text/plain</MIME>
  </DFType>
</DFProperties>
</Node>
<Node>
  <nodeName>ConRefs</nodeName>
  <!-- The ConRefs node starts here. -->
  <DFProperties>
    <AccessType>
      <Get/>
    </AccessType>
    <DFFormat>
      <node/>
    </DFFormat>
    <Occurrence>
      <One/>
    </Occurrence>
    <Scope>
      <Permanent/>
    </Scope>
    <DFTitle>A collection of network access point objects.</DFTitle>
    <DFType>
      <DDFName/>
    </DFType>
  </DFProperties>
  <Node>
    <nodeName/>
    <DFProperties>
      <AccessType>
        <Get/>
      </AccessType>
      <DFFormat>
        <node/>
      </DFFormat>
      <Occurrence>
        <OneOrMore/>
      </Occurrence>
      <Scope>
        <Dynamic/>
      </Scope>
      <DFTitle>The "name" node for a network access point object.</DFTitle>
      <DFType>
        <DDFName/>
      </DFType>
    </DFProperties>
  </Node>

```

```

    <NodeName>ConRef</NodeName>
    <DFProperties>
      <AccessType>
        <Get/>
        <Replace/>
      </AccessType>
      <DFFormat>
        <chr/>
      </DFFormat>
      <Occurrence>
        <One/>
      </Occurrence>
      <Scope>
        <Permanent/>
      </Scope>
      <DFTitle>The ConRef (network access point object).</DFTitle>
      <DFType>
        <MIME>text/plain</MIME>
      </DFType>
    </DFProperties>
  </Node>
</Node>
</Node>
<Node>
  <NodeName>PDP_ContextOperPref</NodeName>
  <DFProperties>
    <AccessType>
      <Get/>
      <Replace/>
    </AccessType>
    <DFFormat>
      <bool/>
    </DFFormat>
    <Occurrence>
      <One/>
    </Occurrence>
    <Scope>
      <Permanent/>
    </Scope>
    <DFTitle>Indication of the operator's preference for a dedicated PDP context for IMS
signalling.</DFTitle>
    <DFType>
      <MIME>text/plain</MIME>
    </DFType>
  </DFProperties>
</Node>
<Node>
  <NodeName>P-CSCF_Address</NodeName>
  <DFProperties>
    <AccessType>
      <Get/>
      <Replace/>
    </AccessType>
    <DFFormat>
      <chr/>
    </DFFormat>
    <Occurrence>
      <ZeroOrOne/>
    </Occurrence>
    <Scope>
      <Dynamic/>
    </Scope>
  </DFProperties>
</Node>

```



```

    </Scope>
    <DFTitle>The address of the P-CSCF.</DFTitle>
    <DFType>
      <MIME>text/plain</MIME>
    </DFType>
  </DFProperties>
</Node>
<Node>
  <nodeName>Timer_T1</nodeName>
  <DFProperties>
    <AccessType>
      <Get/>
      <Replace/>
    </AccessType>
    <DFFormat>
      <int/>
    </DFFormat>
    <Occurrence>
      <One/>
    </Occurrence>
    <Scope>
      <Permanent/>
    </Scope>
    <DFTitle>RFC 3261, timer T1.</DFTitle>
    <DFType>
      <MIME>text/plain</MIME>
    </DFType>
  </DFProperties>
</Node>
<Node>
  <nodeName>Timer_T2</nodeName>
  <DFProperties>
    <AccessType>
      <Get/>
      <Replace/>
    </AccessType>
    <DFFormat>
      <int/>
    </DFFormat>
    <Occurrence>
      <One/>
    </Occurrence>
    <Scope>
      <Permanent/>
    </Scope>
    <DFTitle>RFC 3261, timer T2.</DFTitle>
    <DFType>
      <MIME>text/plain</MIME>
    </DFType>
  </DFProperties>
</Node>
<Node>
  <nodeName>Timer_T4</nodeName>
  <DFProperties>
    <AccessType>
      <Get/>
      <Replace/>
    </AccessType>
    <DFFormat>
      <int/>

```

```

    </DFFormat>
    <Occurrence>
      <One/>
    </Occurrence>
    <Scope>
      <Permanent/>
    </Scope>
    <DFTitle>RFC 3261, timer T4.</DFTitle>
    <DFType>
      <MIME>text/plain</MIME>
    </DFType>
  </DFProperties>
</Node>
<Node>
  <NodeName>Private_user_identity</NodeName>
  <DFProperties>
    <AccessType>
      <Get/>
    </AccessType>
    <DFFormat>
      <chr/>
    </DFFormat>
    <Occurrence>
      <One/>
    </Occurrence>
    <Scope>
      <Permanent/>
    </Scope>
    <DFTitle>The private user identity.</DFTitle>
    <DFType>
      <MIME>text/plain</MIME>
    </DFType>
  </DFProperties>
</Node>
<Node>
  <NodeName>Public_user_identity_List</NodeName>
  <!-- The Public_user_identity_List node starts here. -->
  <DFProperties>
    <AccessType>
      <Get/>
    </AccessType>
    <DFFormat>
      <node/>
    </DFFormat>
    <Occurrence>
      <One/>
    </Occurrence>
    <Scope>
      <Permanent/>
    </Scope>
    <DFTitle>A collection of public user identity objects.</DFTitle>
    <DFType>
      <DDFName/>
    </DFType>
  </DFProperties>
  <Node>
    <NodeName/>
    <DFProperties>
      <AccessType>
        <Get/>
      </AccessType>

```

```

    <DFFormat>
      <node/>
    </DFFormat>
  </Occurrence>
  <OneOrMore/>
</Occurrence>
<Scope>
  <Dynamic/>
</Scope>
<DFTitle>The "name" node for a public user identity object.</DFTitle>
<DFType>
  <DDFName/>
</DFType>
</DFProperties>
<Node>
  <NodeName>Public_user_identity</NodeName>
  <DFProperties>
    <AccessType>
      <Get/>
    </AccessType>
    <DFFormat>
      <chr/>
    </DFFormat>
    <Occurrence>
      <One/>
    </Occurrence>
    <Scope>
      <Permanent/>
    </Scope>
    <DFTitle>The public user identity.</DFTitle>
    <DFType>
      <MIME>text/plain</MIME>
    </DFType>
  </DFProperties>
</Node>
</Node>
</Node>
<Node>
  <NodeName>Home_network_domain_name</NodeName>
  <DFProperties>
    <AccessType>
      <Get/>
    </AccessType>
    <DFFormat>
      <chr/>
    </DFFormat>
    <Occurrence>
      <One/>
    </Occurrence>
    <Scope>
      <Permanent/>
    </Scope>
    <DFTitle>The home network domain name.</DFTitle>
    <DFType>
      <MIME>text/plain</MIME>
    </DFType>
  </DFProperties>
</Node>
<Node>
  <NodeName>Ext</NodeName>
  <!-- The Extension node starts here. -->

```

```
<DFProperties>
  <AccessType>
    <Get/>
    <Replace/>
  </AccessType>
  <DFFormat>
    <node/>
  </DFFormat>
  <Occurrence>
    <ZeroOrOne/>
  </Occurrence>
  <Scope>
    <Dynamic/>
  </Scope>
  <DFTitle>A collection of all Extension objects.</DFTitle>
  <DFType>
    <DDFName/>
  </DFType>
</DFProperties>
</Node>
</Node>
</MgmtTree>
```

Annex B (informative): 3GPP IMS Client Provisioning Application Characteristics (CP AC)

B.1 General

This annex defines the 3GPP IMS Client Provisioning Application Characteristics (CP AC). The definition is based on the Enabler Release Definition OMA-WAP-ProvCont-V1_1-20050428-C [13].

If the initial IMS parameters cannot be provisioned as specified in OMA-ERELD-DM-V1_2-20050607-C [12], initial IMS parameters can be provisioned using OMA CP.

If a client is provisioned with 3GPP IMS related parameters by both OMA DM and OMA CP, the client will use the 3GPP IMS related parameters provisioned by OMA DM.

B.2 Definition of the 3GPP IMS Client Provisioning Application Characteristics

IDENTIFYING INFORMATION

#####

APPID: 3GPP_IMS.

APPID type: OMNA.

Owner: 3GPP CT1 Working Group.

Contact: 3GPP TSG CT WG1.

Registration version: 1.0.

Registration timestamp: 2005-10-01.

Application description: IP Multimedia Subsystem.

Application reference:

IMS specifications, 3GPP TS 24.229, 3GPP TS 23.221 and 3GPP TS 23.228.

URL:<http://ftp.3gpp.org/>.

WELL-KNOWN PARAMETERS

#####

Characteristic/name: APPLICATION/APPID.

Status: Required.

Occurs: 1/1.

Default value: None.

Used values: N/A.

Interpretation: The Application ID - this is the same as for the MO DDF.

Characteristic/name: APPLICATION/NAME.

Status: Required.

Occurs: 0/1.

Default value: ap2001.

Used values: ap2001.

Interpretation: User displayable name for the application.

Characteristic/name: APPLICATION/PROVIDER-ID.

Status: Required.

Occurs: 0/1.

Default value: None.

Used values: N/A.

Interpretation: An identifier for the IMS service provider that provides the client provisioning. This is used to distinguish between settings for different IMS service providers within a client.

 Characteristic/name: APPLICATION/APPREF.

Status: Required.

Occurs: 0/1.

Default value: None.

Used values: N/A.

Interpretation:

The APPREF parameter defines the reference identity of the IMS APPLICATION characteristic. The APPREF parameter value is unique in the scope of the provisioning document. The TO-APPREF parameter included in other APPLICATION characteristic can be used for referring to the IMS APPLICATION characteristic.

 Characteristic/name: APPLICATION/TO-NAPID.

Status: Required.

Occurs: 1/1.

Default value: None.

Used values: N/A.

Interpretation: The reference to the connectivity characteristics used for IMS.

----- APPLICATION-SPECIFIC PARAMETERS

#####

Characteristic/name: APPLICATION/PDP_CONTEXTOPERPREF.

Status: Required.

Occurs: 1/1.

Default value: None.

Used values: 0 and 1.

Interpretation: Indication of the operator's preference for a dedicated PDP context for IMS signalling.

 Characteristic/name: APPLICATION/P-CSCF_ADDRESS.

Status: Optional.

Occurs: 0/1.

Default value: 0.

Used values: N/A.

Interpretation: The address of the P-CSCF in FQDN format or an IPv4 address.

 Characteristic/name: APPLICATION/TIMER_T1.

Status: Required.

Occurs: 0/1.

Default value: N/A.

Used values: Integer.

Interpretation: RFC 3261, timer T1.

 Characteristic/name: APPLICATION/TIMER_T2.

Status: Required.

Occurs: 0/1.

Default value: N/A.

Used values: Integer.

Interpretation: RFC 3261, timer T2.

 Characteristic/parameter: APPLICATION/TIMER_T4.

Status: Required.

Occurs: 0/1.

Default value: N/A.

Used values: Integer.

Interpretation: RFC 3261, timer T4.

----- PARAMETER VALUES

#####

Characteristic/name/parameter: APPLICATION/PDP_CONTEXTOPERPREF/0.

Status: Optional.

Interpretation: Indicates that the operator has no preference for a dedicated PDP context for SIP signalling.

 Characteristic/name/parameter: APPLICATION/PDP_CONTEXTOPERPREF/1.

Status: Optional.

Interpretation: Indicates that the operator has preference for a dedicated PDP context for SIP signalling.

###END###

Annex C (informative): Change history

Change history								
Date	TSG #	TSG Doc.	CR	Rev	Subject/Comment	Old	New	WG doc
2004-10					Version 0.0.1: Preliminary proposal		0.0.1	
2004-11					Version 0.0.2: Version after CN1 #36	0.0.1	0.0.2	
2004-12					Version 1.0.0: Version after CN1#36 and editorial corrections	0.0.2	1.0.0	
2005-02					Version 1.1.0: Version after CN1#37 and editorial corrections	1.0.0	1.1.0	N1-050330 N1-050393
2005-02	TSG-27	NP-050066			Version 2.0.0 created by MCC	1.1.0	2.0.0	
2005-03					Version 2.0.0. approved in TSG-27. V6.0.0 created.	2.0.0	6.0.0	
2005-06	TSG-28	CP-050060	1	1	Corrections to TS 24.167 due to comments from OMA DM	6.0.0	6.1.0	C1-050704
2005-06	TSG-28	CP-050060	2	1	Miscellaneous corrections	6.0.0	6.1.0	C1-050705
2005-06	TSG-28	CP-050060	3	1	Removal of APN from the IMS MO	6.0.0	6.1.0	C1-050706
2005-09	TSG-29	CP-050359	6	-	Corrections for the 3GPP IMS Management Object	6.1.0	6.2.0	C1-050978
2005-09	TSG-29	CP-050359	7	3	IMS MO and ISIM usage clarification	6.1.0	6.2.0	C1-051197
2005-09	TSG-29	CP-050359	9	1	P-CSCF address used in early IMS implementations	6.1.0	6.2.0	C1-051090
2005-09	TSG-29	CP-050360	10	2	Adding Client Provisioning Application Characteristics to IMS MO Rel-6	6.1.0	6.2.0	C1-051091
2005-12	TSG-30	CP-050544	11		AppID for the 3GPP_IMS MO determined by OMA	6.2.0	6.3.0	C1-050544
2006-06	TSG-32	CP-060266	15		Corrections to client provisioning for the 3GPP IMS MO	6.3.0	6.4.0	C1-060627
2006-06	TSG-32	CP-060266	16		Value range for int-parameters	6.3.0	6.4.0	C1-060628
2006-09	TSG-33	CP-06504	14	2	Correction of the reference to OMA DM for the 3GPP IMS MO	6.4.0	6.5.0	C1-061856
2008-03	TSG-39	CP-080119	25		Correction of OMA DM reference	6.5.0	6.6.0	C1-080299
2009-03	TSG-43	CP-090237	0030		MO DDF XML bug fix	6.6.0	6.7.0	C1-090287

History

Document history		
V6.0.0	March 2005	Publication
V6.1.0	June 2005	Publication
V6.2.0	September 2005	Publication
V6.3.0	December 2005	Publication
V6.4.0	June 2006	Publication
V6.5.0	September 2006	Publication
V6.6.0	April 2008	Publication
V6.7.0	March 2009	Publication