

ETSI TS 123 153 V5.0.0 (2002-03)

Technical Specification

**Universal Mobile Telecommunications System (UMTS);
Out of Band Transcoder Control;
Stage 2
(3GPP TS 23.153 version 5.0.0 Release 5)**



Reference

RTS/TSGN-0423153Uv5

Keywords

UMTS

ETSI

650 Route des Lucioles
F-06921 Sophia Antipolis Cedex - FRANCE

Tel.: +33 4 92 94 42 00 Fax: +33 4 93 65 47 16

Siret N° 348 623 562 00017 - NAF 742 C
Association à but non lucratif enregistrée à la
Sous-Préfecture de Grasse (06) N° 7803/88

Important notice

Individual copies of the present document can be downloaded from:

<http://www.etsi.org>

The present document may be made available in more than one electronic version or in print. In any case of existing or perceived difference in contents between such versions, the reference version is the Portable Document Format (PDF). In case of dispute, the reference shall be the printing on ETSI printers of the PDF version kept on a specific network drive within ETSI Secretariat.

Users of the present document should be aware that the document may be subject to revision or change of status. Information on the current status of this and other ETSI documents is available at

<http://portal.etsi.org/tb/status/status.asp>

If you find errors in the present document, send your comment to:

editor@etsi.fr

Copyright Notification

No part may be reproduced except as authorized by written permission.
The copyright and the foregoing restriction extend to reproduction in all media.

© European Telecommunications Standards Institute 2002.
All rights reserved.

DECTTM, **PLUGTESTS**TM and **UMTS**TM are Trade Marks of ETSI registered for the benefit of its Members.
TIPHONTM and the **TIPHON logo** are Trade Marks currently being registered by ETSI for the benefit of its Members.
3GPPTM is a Trade Mark of ETSI registered for the benefit of its Members and of the 3GPP Organizational Partners.

Intellectual Property Rights

IPRs essential or potentially essential to the present document may have been declared to ETSI. The information pertaining to these essential IPRs, if any, is publicly available for **ETSI members and non-members**, and can be found in ETSI SR 000 314: *"Intellectual Property Rights (IPRs); Essential, or potentially Essential, IPRs notified to ETSI in respect of ETSI standards"*, which is available from the ETSI Secretariat. Latest updates are available on the ETSI Web server (<http://webapp.etsi.org/IPR/home.asp>).

Pursuant to the ETSI IPR Policy, no investigation, including IPR searches, has been carried out by ETSI. No guarantee can be given as to the existence of other IPRs not referenced in ETSI SR 000 314 (or the updates on the ETSI Web server) which are, or may be, or may become, essential to the present document.

Foreword

This Technical Specification (TS) has been produced by ETSI 3rd Generation Partnership Project (3GPP).

The present document may refer to technical specifications or reports using their 3GPP identities, UMTS identities or GSM identities. These should be interpreted as being references to the corresponding ETSI deliverables.

The cross reference between GSM, UMTS, 3GPP and ETSI identities can be found under www.etsi.org/key .

Contents

Intellectual Property Rights	2
Foreword.....	2
Foreword.....	5
1 Scope	6
2 References	6
3 Definitions and abbreviations.....	7
3.1 Definitions	7
3.2 Abbreviations	8
4 Out-of-Band Transcoder control functionality.....	8
4.1 OoBTC Requirements	8
4.2 Relationship between OoBTC and In-band TFO	9
4.3 Lawful interception	10
5 General Principles	10
5.1 Network Model	10
5.2 Simple call set-up	11
5.3 Media Gateway Control for Codec Handling	11
5.4 UP Framing Protocol Handling for TrFO.....	12
5.4.1 Framing Protocol Initialisation	12
5.4.2 RFCI Storage	14
5.4.3 RFCI Value Correction	15
5.4.4 TrFO Break	15
5.4.5 TrFO Break Recovery.....	15
5.4.6 MGW Control Protocol Iu Framing Package properties.....	16
5.5 TrFO/TFO Codec Negotiation Harmonisation.....	16
5.6 CN Node handling of Codec Types & Codec Modes.....	18
5.7 Inband Rate Control	19
5.8 Modification Procedures	19
5.8.1 Modification of Selected Codec.....	19
5.8.2 Modification of Available Codec List	21
5.8.3 Mid-call Codec negotiation.....	21
5.9 DTMF Handling For TrFO Connections.....	21
6 Detailed Call Procedures	22
6.1 Mobile to Mobile TrFO Call Establishment.....	22
6.2 SRNS Relocation during TrFO	25
6.3 IN and Call Forward SS	28
6.3.1 TrFO interworking with SS (VMSC = service interworking node).....	29
6.3.2 IN interworking (VMSC ≠ service interworking node).....	31
6.4 Information flow for interaction with Multiparty SS	32
6.5 Information flow for handover from UMTS to GSM after TrFO establishment.....	33
6.6 Call Hold/Call Wait.....	34
6.7 External Network to Mobile TrFO Call Establishment.....	39
6.8 Mobile to External Network TrFO Call Establishment.....	40
7 Interactions with supplementary services.....	40
7.1 Call Deflection service (GSM 23.072).....	40
7.2 Line identification services (GSM 23.081)	41
7.2.1 Calling Line Identification Presentation (CLIP).....	41
7.2.2 Calling Line Identification Restriction (CLIR).....	41
7.2.3 Connected Line Identification Presentation (COLP).....	41
7.2.4 Connected Line Identification Restriction (COLR).....	41
7.3 Call forwarding services (GSM 23.082).....	41
7.3.1 Call Forwarding Unconditional (CFU).....	41

7.3.2	Call Forwarding on mobile subscriber Busy (CFB)	41
7.3.3	Call Forwarding on No Reply (CFNRy).....	41
7.3.4	Call Forwarding on mobile subscriber Not Reachable (CFNRc).....	41
7.4	Call wait (GSM 23.083)	41
7.5	Call hold (GSM 23.083).....	41
7.6	Multiparty (GSM 23.084).....	41
7.7	Closed user group (GSM 23.085).....	42
7.8	Advice of charge (GSM 23.086)	42
7.9	User-to-user signalling (GSM 23.087)	42
7.10	Call barring (GSM 23.088).....	42
7.10.1	Barring of outgoing calls	42
7.10.2	Barring of incoming calls	42
7.11	Explicit Call Transfer (GSM 23.091).....	42
7.12	Completion of Calls to Busy Subscriber (3G TS 23.093)	42
8	Charging	42
Annex A (informative): Codec Re-negotiation.....		43
Annex B (informative): Status of Technical Specification 23.153		44
History		46

Foreword

This Technical Specification has been produced by the 3rd Generation Partnership Project (3GPP).

The contents of the present document are subject to continuing work within the TSG and may change following formal TSG approval. Should the TSG modify the contents of the present document, it will be re-released by the TSG with an identifying change of release date and an increase in version number as follows:

Version x.y.z

where:

- x the first digit:
 - 1 presented to TSG for information;
 - 2 presented to TSG for approval;
 - 3 or greater indicates TSG approved document under change control.
- y the second digit is incremented for all changes of substance, i.e. technical enhancements, corrections, updates, etc.
- z the third digit is incremented when editorial only changes have been incorporated in the document.

1 Scope

The present document specifies the stage 2 description of the Out-of-Band Transcoder Control for speech services. It describes the principles and procedures to support Transcoder Free Operation, Tandem Free Operation and the interworking between TrFO and TFO. Transcoder at the edge is also part of the present document.

2 References

The following documents contain provisions which, through reference in this text, constitute provisions of the present document.

- References are either specific (identified by date of publication, edition number, version number, etc.) or non-specific.
- For a specific reference, subsequent revisions do not apply.
- For a non-specific reference, the latest version applies. In the case of a reference to a 3GPP document (including a GSM document), a non-specific reference implicitly refers to the latest version of that document *in the same Release as the present document*.

- [1] 3GPP TS 23.107: "QoS Concept and Architecture".
- [2] 3GPP TS 24.008: "Mobile radio interface layer 3 specification Core Network Protocols –Stage 3".
- [3] 3GPP TS 25.413: "UTRAN Iu Interface RANAP Signalling".
- [4] 3GPP TS 25.415: "UTRAN Iu Interface User Plane Protocols".
- [5] 3GPP TS 26.103: "Speech codec list for GSM and UMTS".
- [6] 3GPP TS 29.205: "3rd Generation Partnership Project; Technical Specification Group CoreNetwork; Application of Q.1900 series to Bearer Independent circuit-switched core Network architecture; Stage 3".
- [7] ITU-T Recommendation Q.765.5: "Signalling system No. 7; Application transport mechanism: Bearer Independent Call Control (BICC)".
- [8] 3GPP TS 23.205: "Bearer-independent CS Core Network".
- [9] 3GPP TS 33.106: "3GPP Security; Lawful Interception Requirements".
- [10] 3GPP TS 28.062: "Inband Tandem Free Operation (TFO) of Speech Codecs; Service Description; Stage 3".
- [11] 3GPP TS 23.009: "Handover Procedures".
- [12] 3GPP TS 29.232: "Media Gateway Controller (MGC) – Media Gateway (MGW) interface; Stage 3".
- [13] ITU-T H.248: "Gateway Control Protocol".
- [14] 3GPP TS 29.415: "Customised Applications for Mobile network Enhanced Logic (CAMEL) Phase 3; CAMEL Application Part (CAP) specification".

3 Definitions and abbreviations

3.1 Definitions

For the purposes of the present document, the following definition apply:

Codec: device to encode information from its original representation into an encoded form and to decode encoded information into its original representation

Tandem Free Operation: configuration of a connection with two transcoders that support TFO protocol and whose external coding schemes are compatible, thus enabling compressed speech to pass between them

NOTE 1: When the TFO protocol is not supported by both transcoders or the coding schemes are not compatible then normal "Tandem" operation occurs and PCM encoded speech is passed between them.

Transcoder: device to change the encoding of information from one particular encoding scheme to a different one, most commonly to/from a compressed speech algorithm from/to PCM.

Transcoder Free Operation: configuration of a speech or multimedia call for which no transcoder device is physically present in the communication path and hence no control or conversion or other functions can be associated with it

Out of Band Transcoder Control: capability of a system to negotiate the types of codecs and codec modes on a call per call basis through out-of-band signalling, required to establish Transcoder Free Operation.

Default PCM Codec: network default codec for speech in PCM domain

NOTE 2: For example ITU G.711.

Transcoding free link (TrFL): bearer link, where compressed voice is being carried between bearer endpoints

NOTE 3: Within the UMTS network, the compressed voice is transmitted in Iu/ Nb User Plane format, depending on the related interface.

Tandem free link (TFOL): bearer link between transcoders that are operating in Tandem Free Operation mode, i.e. bypassing the transcoding functions

NOTE 4: The involved transcoders can be a UMTS transcoder or a GSM TRAU with TFO functionality.

Transcoder free operation (TrFO): calls that have no transcoders involved in the connection between the source codecs

NOTE 5: For mobile to mobile calls this is UE to UE, although the connection could be UE to another type of terminal. TrFO operation is considered a concatenation of TrFLs between RNCs.

NOTE 6: In case of mobile to fixed network calls the term "Transcoder free operation" is applicable for the TrFLs carrying compressed speech. The TrFO usually ends at the Gateway to the PSTN where the speech is transcoded e.g. to G.711.

Tandem free and Transcoding free operation (TaTrFO): concatenation of "transcoding free links" and "tandem free links"

Iu Framing: framing protocol used for the speech packets on both the Iu User Plane interface and the Nb User Plane interface

NOTE 7: The Iu framing protocol is specified by [4].

3.2 Abbreviations

For the purposes of the present document, the abbreviations defined in GSM 01.04 and the following apply:

APM	Application Transport Mechanism
BC	Bearer Control
BICC	Bearer Independent Call Control
CC	Call Control
CCD	Conference Call Device
CFNRc	Call Forward Not Reachable
CFNRy	Call Forward on No Reply
IN	Intelligent Network
IuFP	Iu Framing Protocol
OoBTC	Out-of-Band Transcoder Control
QoS	Quality of Service
RAB	Radio Access Bearer
TFO	Tandem Free Operation
TICC	Transport Independent Call Control
TrFO	Transcoder Free Operation
UP	User Plane

4 Out-of-Band Transcoder control functionality

Cellular networks depend heavily on codecs to provide their services. Codecs are necessary to compress speech in order to utilise efficiently the expensive bandwidth resources both in the radio interface and in the transmission networks.

Unnecessary transcoding of speech significantly degrades quality and, therefore, cellular systems try to avoid it for mobile-to-mobile calls when both UEs and the network support a common codec type.

Although the main reason for avoiding transcoding in mobile-to-mobile calls has been speech quality, the transmission of compressed information in the CN and CN-CN interface of the cellular network also offers the possibility of bandwidth savings. Therefore Out-of-Band Transcoder Control is not limited to mobile-to-mobile calls but can be applied for calls to or from an external network as well.

Digital cellular systems support an increasing number of codec types. As a result, in order to allocate transcoders for a call inside the network, and to select the appropriate codec type inside the UEs, signalling procedures are defined to convey the codec type selected for a call to all the affected nodes (UEs and (potential) transcoding points inside the network). Also, codec negotiation capabilities are being defined to enable the selection of a codec type supported in all the affected nodes, i.e. to resolve codec mismatch situations. This codec negotiation maximises the chances of operating in compressed mode end-to-end for mobile-to-mobile calls.

To allow transport of information in a compressed way in transmission networks, these networks make use of the transport -independent call control protocol as specified in [8] that provides means for signalling codec information, negotiation and selection of codecs end-to-end.

4.1 OoBTC Requirements

The OoBTC mechanism shall support the following:

- The capability to negotiate the preferred codec type to be used between two end nodes and to avoid the use of transcoders in the network at call set-up.

The originating UE indicates the list of its supported codec types for codec negotiation. This list shall be conveyed to the terminating MSC. The terminating UE indicates its list of supported codec types to the terminating MSC. The terminating MSC shall convey the selected codec to the originating MSC, which then indicates the selected codec to the originating UE.

Where no compatible codec type can be selected between the UEs then the default PCM coding shall be selected. The originating MSC shall insert a transcoder in the path from the originating UE. Codec selection for the terminating UE is then performed within the terminating MSC, independently of the originating MSC.

NOTE: For a codec type supporting various modes, the described functionality shall also be applicable to negotiate the set of codec modes common to originating and terminating UEs. Other negotiations such as Initialisation and Rate control are performed at a later point in time by the Iu framing protocol.

- The capability to control the presence of transcoders in the network after call set-up.

Where a change to the call state of a transcoder free connection occurs, such that compressed speech cannot be maintained, it shall be possible to insert a transcoder or pair of transcoders where needed in the path. If this results in change to the encoding of the speech in other nodes then it shall be possible to inform the end points of this segment that the speech coding is changed. Such examples where this could occur are:

- SS interruptions (e.g. A to B call connection becomes to multiparty call connection.)
- Handover to an incompatible partner.
- Synchronisation loss

Where a change in call state as described above is temporary then it shall be possible to return to a transcoder free connection by removing the inserted transcoders and informing the endpoints that the connection has resumed to compressed speech encoding.

- The codec types comprise codecs for speech in the first phase of the present document. The transcoder control should have enough expandability to support future enhancements of codec types.
- The transcoder control procedure shall not cause a perceivable time lag in the cases of establishing transcoder free connection and reverting to normal (double transcoded) call connection in the cases described above for control of the presence of transcoders.
- The capability to insert transcoder (in cases where a TrFO connection is not possible) at the most appropriate location, i.e. to save bandwidth it should be located at the CN edge between an ATM or IP transport network and a STM network. When Transcoders are inserted, the OoBTC procedures shall provide support for TFO for inband codec negotiation and transmission of compressed speech.

When a transport network cannot maintain compressed voice then reversion to the default PCM coding shall occur. A transcoder shall be inserted at that point and OoBTC procedures terminated. TrFO link is then possible between that point and the preceding nodes.

When a Non-TrFO call reaches the UMTS CN then OoBTC procedures are initiated from that point and after codec negotiation has been performed, if compressed voice can be supported through the CN then a transcoder is inserted at the edge of the CN.

- The OoBTC signalling procedures shall be supported by the call control protocol on the Nc interface, for example codec negotiation, codec modification, codec list modification, codec renegotiation, and codec list renegotiation. BICC CS2 (see 3GPP TS 29.205 [6]) supports such a mechanism, through the APM procedures defined by [7].
- The OoBTC signalling procedures shall be supported by the bearer control protocol on the Iu and Nb interfaces, for example to increase the bandwidth of the bearer (if needed) in the procedures for the codec modification.

4.2 Relationship between OoBTC and In-band TFO

OoBTC is used before call set-up to attempt to establish an UE-UE transcoder free connection. If successful the result is a saving of transcoding equipment in the path and provides a cost efficient transmission.

The In-band TFO protocol (described in [10]) is activated after call set-up only if transcoders are inserted in the path. In case two transcoders in tandem (a pair of transcoders with PCM coding between them) are able to communicate to each other (both support TFO), then the inband TFO protocol allows the transcoders to compare coding schemes. If compatible codec types exist, the transcoders are able to overwrite the PCM coding with the pure compressed speech (effectively bypassing the transcoding functions). In-band TFO provides fast fallback mechanisms in case the TFO connection can not be maintained (insertion of CCD, DTMF, tones, etc). In-band TFO provides no direct saving of transmission costs.

If the OoBTC fails to establish the TrFO and transcoders are required, then in-band TFO may be used after call set-up. Inband TFO shall be the fallback mechanism when transcoders cannot be avoided, either at set-up or during the communication phase. In-band TFO shall be used for interworking with the 2G systems (e.g. GSM).

4.3 Lawful interception

The TrFO shall be maintained if the interception is made due to the lawful interception. Two decoders are needed to monitor the TrFO call.

Lawful interception shall not have any influence on the establishment or maintenance of the TrFO connection in order to avoid any audible effect in speech quality or noticeable effect in speech delay to the end users.

The existing requirements for lawful interception shall be considered, these are described in [9].

5 General Principles

5.1 Network Model

The codec negotiation mechanism (OoBTC) is designed to work in the general situation where more than two call control (CC) nodes need to participate in the codec negotiation. The codec negotiation mechanism works as follows:

- Originating CC node: sends its list of supported codec types and options, listed in order of preference.
- Transit CC nodes: if needed, analyse the received list of options, delete unsupported options from the list and forward the list. No modification is done to the preference levels of any of the listed codecs.
- Terminating CC node: analyse the received list of options with their associated priorities and selects the supported option with highest indicated priority.

Figure 5.1/1 illustrates the architecture for Rel-4 for UMTS to UMTS TrFO connection. The transit network may exist for calls between PLMNs or between islands of mobile CNs separated by transit networks. This figure is a basic illustration, OoBTC shall apply to other access technologies where the OoBTC procedures are supported, i.e. not limited to this figure. The negotiation occurs at call set-up phase, and possibly later on in the call due to other changes such as handover or relocation. *However, as described in the next clause, it shall be possible to modify the selected codec at any moment during the active phase of the call.*

Further detail of the Call & Bearer Separation for 3GPP is described in [8].

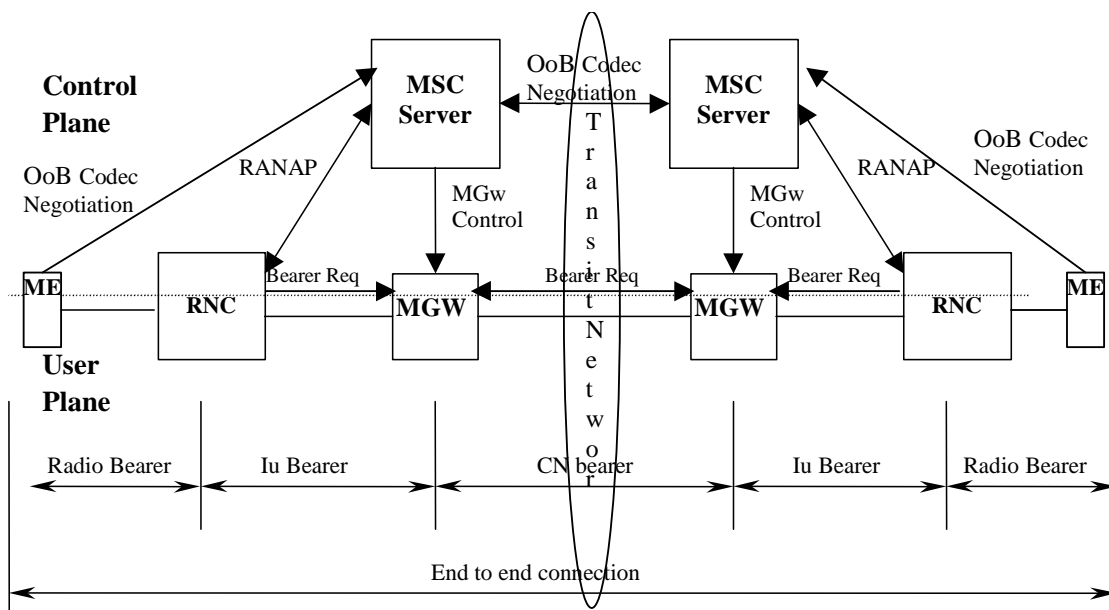

Figure 5.1/1. Basic Architecture for UMTS to UMTS TrFO Connection

The following clauses describe successful call establishment scenarios using the codec negotiation mechanism.

5.2 Simple call set-up

The signalling flow for the simple call set-up case is illustrated in figure 5.2/1. Codec negotiation is done prior to the establishment of bearer connections, so that appropriate bearer resources are committed to the call. In the proposed sequence, the codec negotiation starts with the IAM message containing the list of supported codec types (in this example v, w, x, y, z), sent by the Originating MSC (O-MSC). Transit nodes may puncture out (i.e. delete) codec types from the list (in this example y). The terminating MSC (T-MSC) selects the codec type (here v). The selected codec is conveyed in an APM message, together with the remaining list of alternative, but currently not selected codec types (here v, x, z).

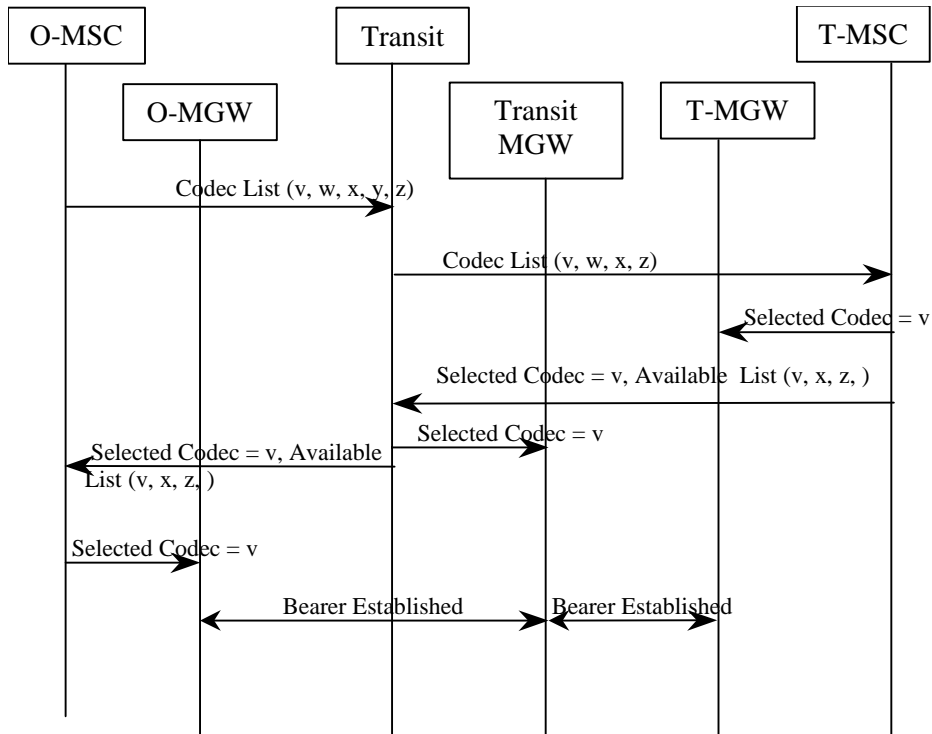

Figure 5.2/1. Basic Codec Negotiation Sequence

The codec list for BICC is specified according to [7], where each 3GPP codec entry is defined according to [5].

5.3 Media Gateway Control for Codec Handling

The general handling of MGW control procedures are detailed in [8]. Specific handling related to the control of the speech encoding is detailed in Figure. 5.3/1. The terms context, termination, streams and stream properties are described in the ITU-T H.248 "Media Gateway Control Protocol" [13].

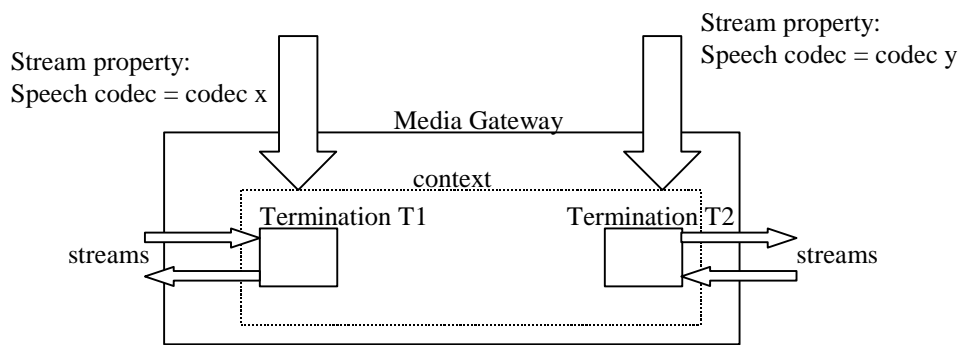

Figure 5.3/1. MGW control for speech codec

The handling of transcoding between one codec type (media stream property applied at one termination) and another codec type (media stream property at other termination) is a function of the MGW. The media stream property for Audio Codec Type is defined in Annex C of the ITU-T MGW control protocol, H.248.

5.4 UP Framing Protocol Handling for TrFO

5.4.1 Framing Protocol Initialisation

For TrFO calls the compressed speech is carried end to end (RNC to RNC or between RNC and other compressed voice terminal). In 3GPP Core Networks compressed voice framing protocol shall be specified by the Nb User Plane specification. The specification for Iu interface is defined in [4], the specification for the Nb interface is defined in [12]. The framing protocol for these interfaces is the same, Iu framing and is thus described as such, for both the Iu interface and the Nb interface. For compressed voice only the support mode is used, thus for TrFO the UP Initialisation procedure defined for the Nb UP shall be supported by the CN, when a CN MGW is required to establish a connection.

When negotiating TrFO OoB, a given serving MSC server shall consider the capabilities of the RNCs and MGWs, which are candidates to handle the TrFO call and which are controlled by this MSC server via an Iu/Mc interface. For TrFO, the selected RNC and MGW have to be able to support at least one Iu/Nb UP version with TrFO capabilities. Each MGW and RNC that supports TrFO shall support Iu/Nb UP version 2. If an RNC only supports Iu UP version 1 without TrFO capabilities, the MSC server shall insert a transcoder at the MGW that is connected to this RNC. For a TrFO call, each MSC server shall indicate in the "RAB assignment"/"Add request" only UP versions with TrFO capabilities. In the inband UP framing protocol version negotiation during framing protocol initialisation, the informed RNCs/MGW shall only offer and/or accept UP version listed in the "RAB assignment"/"Add request".

The Iu framing Protocol is established through the CN in a forward direction, independently of the bearer establishment direction. The Notify message to indicate bearer establishment shall not be sent until the Iu framing has been initialised. The continuity message (COT) shall not be sent forward until the Notify message has been received from the MGW and also the COT from the previous server has been received. The sequences for mobile originated calls are shown in figures 5.4/1 and 5.4/2 for forward bearer and backward bearer establishment, respectively. The parameters in the Add Request messages in the Figures are described in further detail in clause 5.4.5.

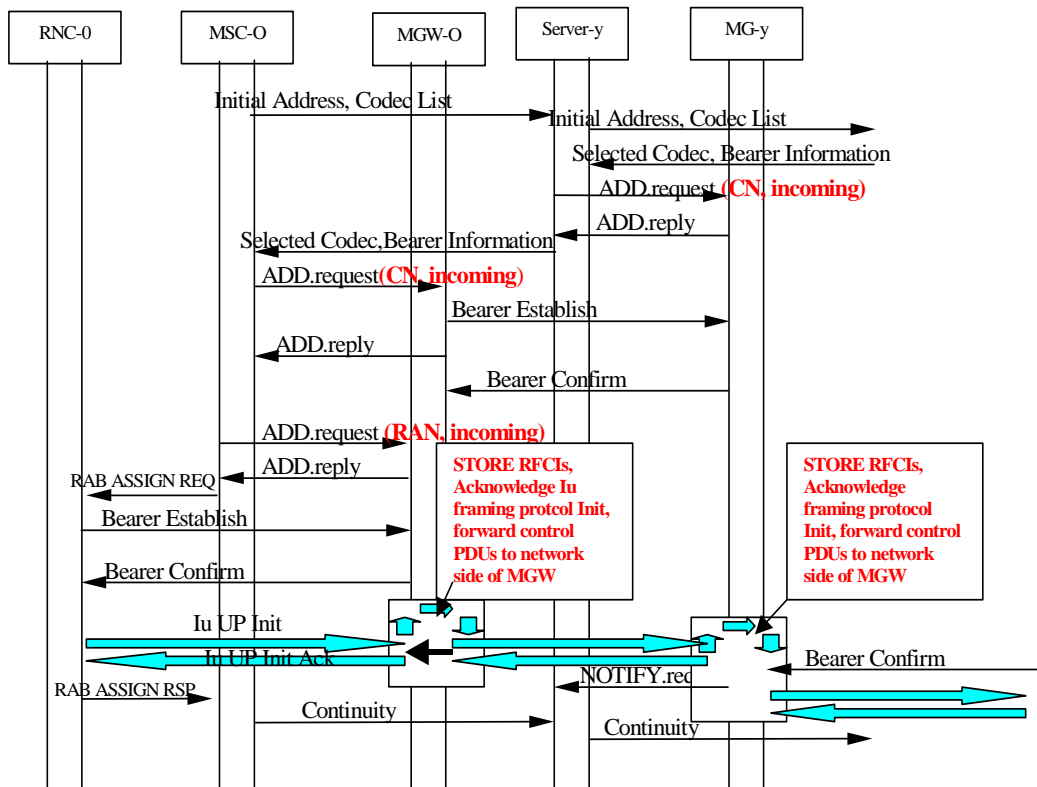

Figure 5.4.1/1: Iu Framing Protocol Establishment, Forward Bearer

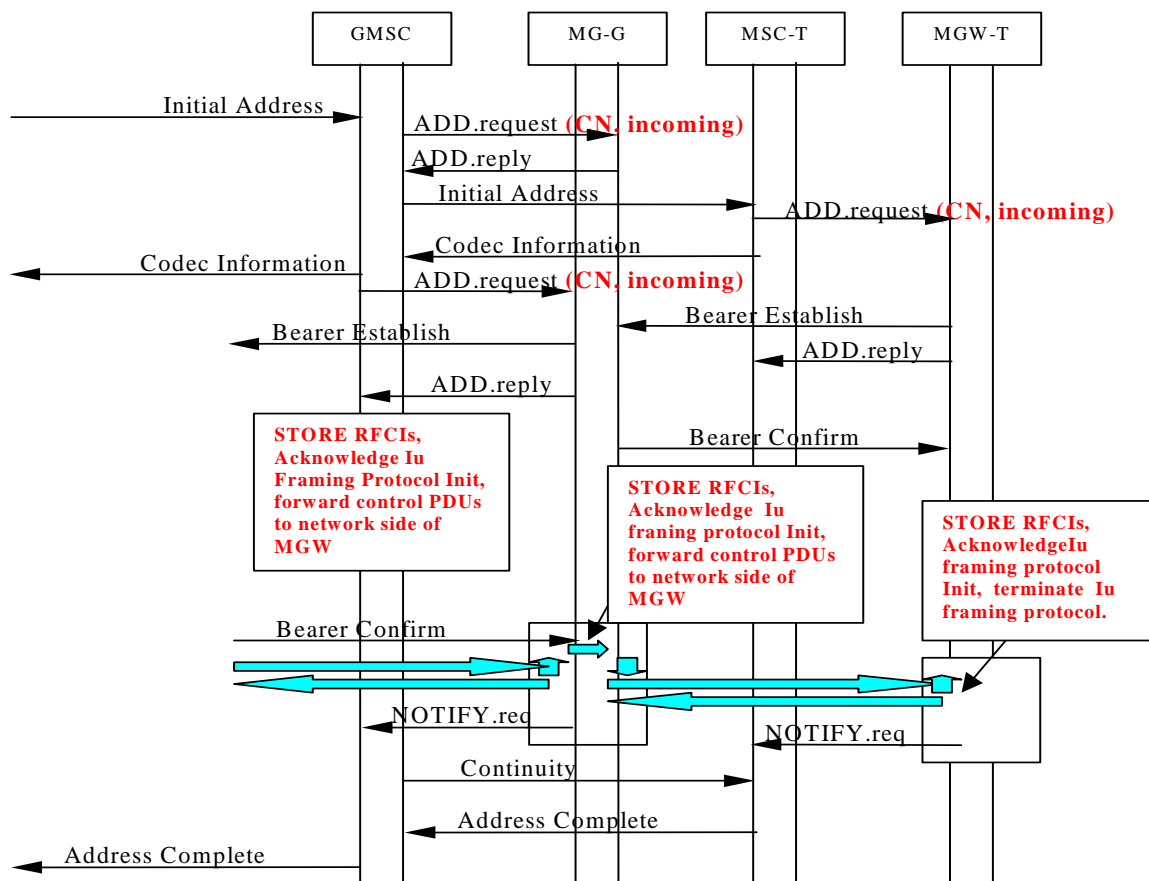

Figure 5.4.1/2: Iu Framing Protocol Establishment, backward bearer.

The transport independent call control procedures in [8] shall support a continuity mechanism, as described above.

5.4.2 RFCI Storage

The RNC shall allocate RAB Subflow Combination Indicators to the SDU formats (SDU formats sent to the RNC by the MSC in the RAB Assignment). This allocation is then sent in the Iu Framing Initialisation PDU by the RNC in the User Plane. For further details see [3] and [4].

During the TrFO call establishment each MGW linked into the call shall store the RFCIs received from Iu Framing PDU Type 14.

After the out of band codec negotiation has been performed, if the originating side is a UTRAN, then on request from the MSC for a RAB Assignment, it shall initiate the Iu user plane. If the originating side is a network that does not support Iu Framing then the Iu Framing initialisation is initiated by the GMSC, as described in detail in Clause 6.7. An Initialisation Protocol Data Unit (PDU) shall be sent to the first MGW in the call connection. Each initialisation leg is acknowledged per TrFO Link, i.e. per MGW-MGW interface. The subsequent initialisation is performed using the same RFCI set as received from the preceding node, independently of the Stream mode directions (i.e. if the terminations are not through connected).

This is shown figure 5.4.2/1.

Figure 5.4.2/1: RFCI Storage and subsequent initialisation in MGW

When the MGW terminations are through-connected and the RFCIs at both terminations are matching, then the MGW may revert to transparent mode; the RNCs shall not perform any subsequent Iu Framing initialisations without explicit request by the serving MSCs.

All succeeding MGWs in the path shall behave in a similar way as described above.

5.4.3 RFCI Value Correction

At the terminating end of a TrFO connection with Iu Framing initialised to the terminating MGW, the originating RFCI allocation is stored. The terminating RNC is then requested to perform a RAB Assignment towards the terminating MGW. This results in an Iu Framing initialisation, where the allocation of the RFCI values is independent from the Originating RNC's allocation. These values may then be different to the originating RNC's set.

The terminating MGW shall acknowledge the Iu Framing Initialisation and compare the RFCI values stored from the originating side. If the allocated index values do not match, then the MGW shall either:

- 1) initiate an Iu Framing Initialisation PDU towards the terminating RNC with the RFCI allocation as defined by the preceding node (previously stored in the MGW. This behavior is shown in figure 5.4.3/1 and termed "RFCI value correction"), or
- 2) map the RFCI indices of the incoming side to the corresponding RFCI indices at the outgoing side for all SDUs passed between the Iu Framing protocol terminations.

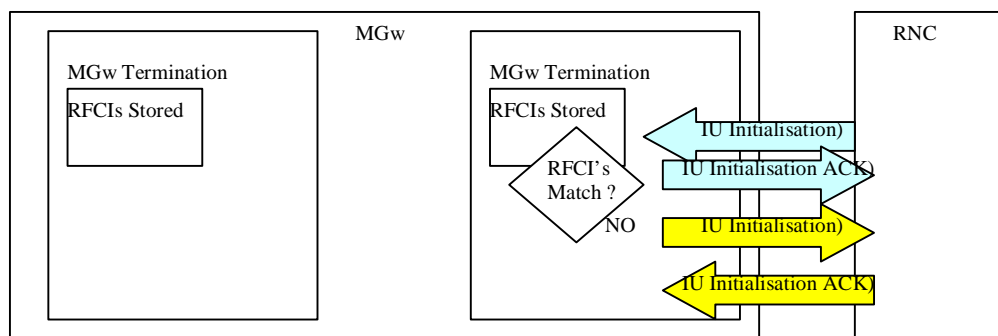

Figure 5.4.3/1:RFCI Value Correction

Further details of the TrFO call establishment are described in clause 6.

This resolution handling is required also during RNC relocation; further details are described in clause 6.

5.4.4 TrFO Break

The event and procedure when a TrFO connection must be interrupted at a certain point in the path, e.g. due to a supplementary service invocation or for handover/relocation, is termed "TrFO Break". A TrFO Break may occur at a MGW as a consequence of a command directed by the associated Server. During this period the Iu User Plane protocol is terminated by this MGW, in general at both sides of the MGW. This means that it must respond to new Initialisation PDUs and Inband Rate Control PDUs. The MGW inserts a TrFO Break Function, which then makes use of the stored RFCI values, in order to perform the required Iu Framing protocol functions and interpret the payload. Further call scenarios for specific services that incur a TrFO break are described in clause 6..

5.4.5 TrFO Break Recovery

During the TrFO break situation the individual connections are free to change, the RFCIs may have changed and also the rate control (maximum rate, current rate). After the service that caused the TrFO break is complete, the MGW shall check if TrFO can be re-established. If the coding schemes are matching but the RFCI's have changed then RFCI value correction can be performed at the RNC side. In order to correct any changes in rate control between two RNCs, the MGW shall send a rate control request from each Termination, with the current rate and maximum rate applied at the other Termination. This will then result in the Distributed Rate Decision between the two RNCs in the call.

5.4.6 MGW Control Protocol Iu Framing Package properties

The following is a summary of the Iu Framing H.248 requirements; the procedures are described in [12] and are valid for Iu Framing in Support Mode:

Additional Package Properties:

Iu Framing Termination Type: Values - Iu-RAN (Iu Framing Protocol on Iu Interface)

- Iu-CN (Iu Framing Protocol on Nb Interface)

Iu Framing Initialisation Procedure: Values – Incoming (For Iu-CN: the Iu Framing Protocol initialisation is received by the media gateway and used for subsequent initialisation from this MGW. For Iu-RAN this indicates the originating RNC interface).

- Outgoing (For Iu-CN the Iu Framing Protocol is generated by the core network MGW, i.e. initialised on the Nb Interface. For the Iu-RAN interface this specifies the terminating RNC Interface)

5.5 TrFO/TFO Codec Negotiation Harmonisation

When OoBTC procedures are initiated to a node where compressed voice cannot be supported (either at the node or to the preceding node) then a transcoder is inserted. This can be due to the transport technology (e.g. TDM) or due to the access technology (e.g. GSM). The OoBTC procedures can result in the following call scenarios:

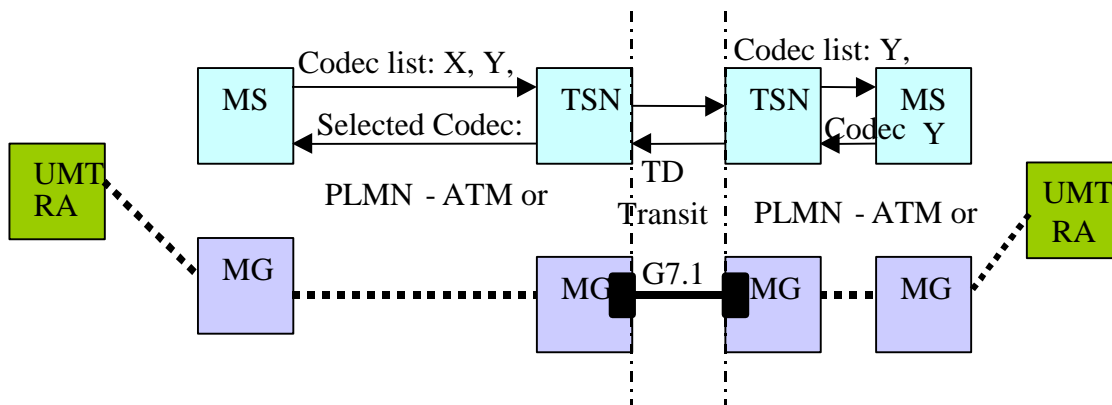

Figure 5.5/1: Cascaded TrFO & Transcoding

In Figure 5.5/ 1 the OoBTC cannot proceed as the call crosses a transit network that does not support compressed voice. The same could occur if the transit network did not support out of band codec negotiation (Support in BICC is optional).

In Figure 5.5/2 the OoBTC procedures result in the call terminating to a GSM access. As the GSM radio access transcodes to default PCM codec, the OoBTC results in default PCM being the only codec that can be selected. The reply is passed back to the originating network, which then inserts a transcoder from default PCM to AMR for the UMTS radio access.

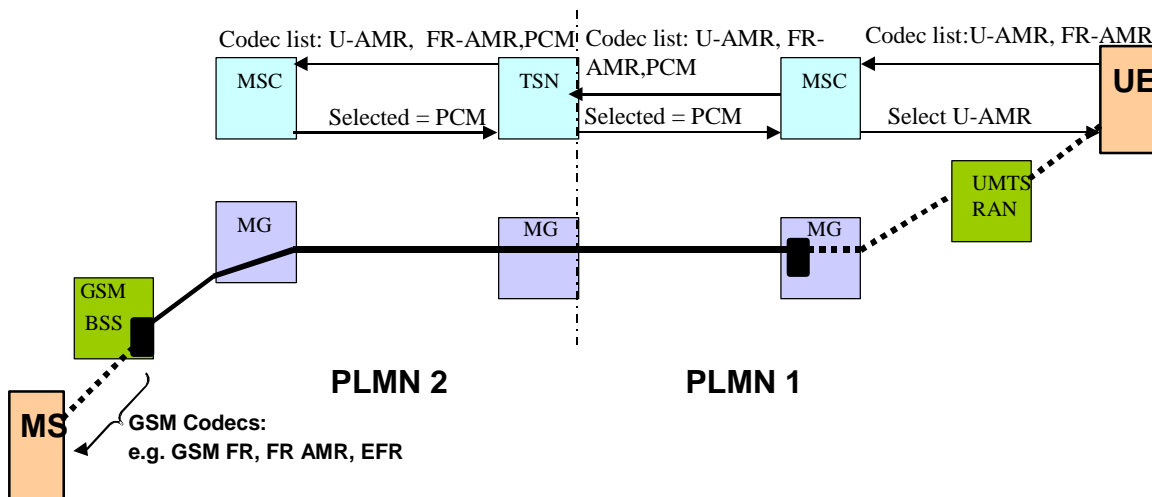

Figure 5.5/2: UMTS to GSM interworking

For TFO to establish between the transcoders in the above scenarios, each TRAU must send a codec list inband after the call has been established. If a common codec type is available (determined by pre-defined rules, described in TFO specification [10]) then the OoBTC procedures need to be informed so that a codec modification can be performed. This is shown in Figure 5.5/3. Note – a modification could also be required when a common codec type has been selected but the ACS is not common.

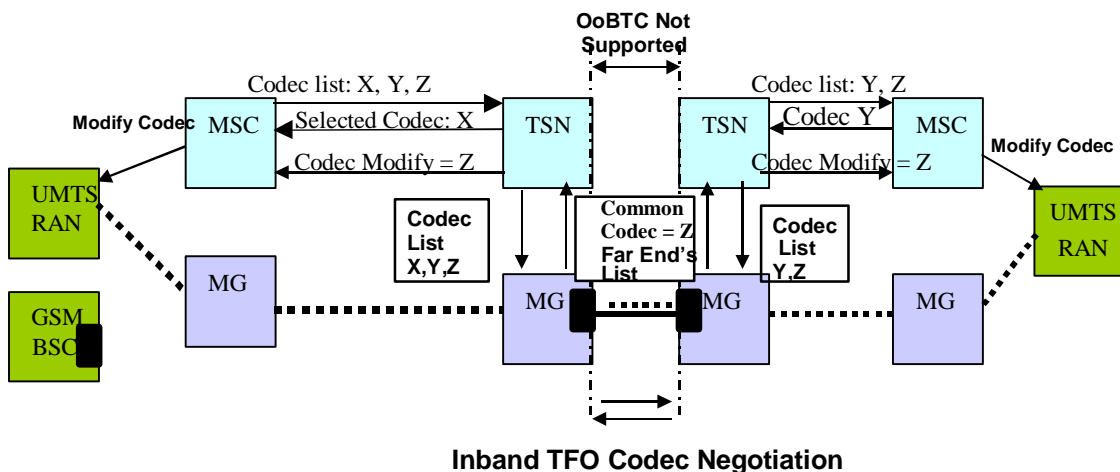

Figure 5.5/3: TFO support by OoBTC signalling

In H.248, the vertical MG control protocol, the coding types are specified by Media Stream Property, as defined by Annex C of H.248 specification. A specific package is used for TFO.

The basic requirements are listed below:

- i) Property for Codec List (same format as for [5])
- ii) Event for common codec determined by TFO protocol
- iii) Event for Far End's Codec List
- iv) Procedures to define TFO

The TFO package allows the Server to request the MGW to initiate TFO protocol towards a far end transcoder. The package includes a property to turn off the TFO (TFO_Active); this may be required prior to TrFO break situations such as handover. The control of the level of negotiation is performed by the "Optimisation Mode" parameter in the Codec List IE see [5]. This allows a node to indicate if the ACS may be punctured or not and this is mapped to the appropriate parameter in the TFO protocol by the MGW.

The MGW returns Notification Events for the Far End's Codec List and Common Codec as selected by the Codec Selection mechanism in TFO. The Server then compares the "Far End Codec List" with its previously negotiated Available Codec List. If the lists are not the same then a Codec List Modification is also performed.

5.6 CN Node handling of Codec Types & Codec Modes

The supported codec list received by the MSC in DTAP protocol [2] has no priority, whereas the list sent in the OoBTC procedures is sent with a level of preference.

The default Codec Type for "R99 UMTS only" terminals is UMTS_AMR, the default Codec Type for all terminals supporting GSM and UMTS radio access is UMTS_AMR_2, see [5] for the detailed description. The UMTS_AMR_2 is a superset of the UMTS_AMR. It behaves as a FR_AMR codec in the UL and as a UMTS_AMR codec in the DL. This allows UMTS terminals to operate in TFO with GSM terminals. The UMTS_AMR_2 is fully compatible with UMTS_AMR in TFO and TrFO and fully compatible with R99 CN nodes (TC in MGW).

If the UE supports both Codec Types (UMTS_AMR and UMTS_AMR_2), then the MSC shall indicate only the UMTS_AMR_2 in the OoBTC codec negotiation. If no Codec List IE is received and the UE is "UMTS only", then the MSC shall assume UMTS_AMR as supported Codec Type. If no Codec List IE is received, but the UE is "dual system", then the MSC shall assume UMTS_AMR_2 as the supported codec type. The MSC shall assume "dual system" support only if the UE indicates at least one GSM speech version in Octet 3a etc. of the Bearer Capability.

In order to support interworking with 2G systems it is recommended that MGWs support 2G EFR codecs (GSM_EFR, PDC_EFR, TDMA_EFR). In order to avoid modifications during handover between 2G and 3G systems the MSC nodes may give preference to a suitable 2G codec.

The originating CN node, while performing speech service negotiation with a terminating CN node, shall indicate the maximum number of codec modes that shall be selected during speech codec negotiation. This maximum number of supported codec modes may depend on optimisation strategies applied by the originating CN node. The recommended value is "four" (see [10]).

The terminating CN node receiving this information compares the maximum number of codec modes received by the originating CN with its own one and shall decide on the minimum of both numbers to be applied as result of the negotiation.

The decision about the actual codec modes to be selected as the Active Codec Set (ACS) shall be left to the terminating CN node. In order to provide harmonisation of out of band codec negotiation (TrFO) and inband codec negotiation (TFO) very similar codec selection mechanisms as those being defined for TFO shall be applied for TrFO, see [10]. These rules shall be taken into account when forwarding a codec list from the originating node to proceeding node, both for TrFO and TFO.

Whenever one or several TrFO links have been already established and initialised, the CN node (e.g. the serving CN in case of Call Hold scenarios, the visited CN node in case of Call Forwarding scenarios, etc.) initiating a subsequent codec negotiation, shall give the already negotiated codec type, including its ACS, highest preference to reduce the possibility of performing bearer re-establishment or UP re-initialisation of the already established and initialised TrFO links.

When the MSC node requests a RAB assignment the Subflow Combinations provided shall either all be initialised by the RNC or all rejected with appropriate cause code.

The MSC shall always assume "Discontinuous Transmission (DTX)" as mandatory and shall define "SID" SDUs in addition to the negotiated speech codec modes. This is because for TrFO the RAB requested by one RNC must match that requested by the peer RNC – they are effectively the same RAB. If one MSC requires DTX support then the RAB requested by the far end MSC must also support DTX (even if it is not desired by that MSC). As no Out Of Band negotiation for DTX is supported nor DTX control to the UE, DTX shall be mandatory for TrFO connections.

5.7 Inband Rate Control

Inband rate control shall only allow the RNCs to set the maximum codec mode (maximum bitrate) from the set of codec modes that have been negotiated out of band. This procedure is called Maximum Rate Control. The final maximum mode selected results from a rate control request from one side and the maximum rate supported at the receiving side; the lower rate of these is selected. This is known as Distributed Rate Decision. In TrFO maximum rate control shall be supported through the Iu Framing protocol and through transit networks supporting compressed voice. The maximum rate control procedures are further defined within the Iu Framing protocol [4].

When the MSC requests for a RAB to be assigned, it shall always define 1 speech mode SDU (lowest rate), and DTX SDU as non-rate controllable. Other SDU formats for higher rates shall be defined as rate controllable.

At SRNS relocation the new RNC shall send a rate control frame at Relocation Detect indicating its current maximum rate, it will receive in the acknowledgement the current maximum rate from the far end. This procedure is called Immediate Rate Control. Again the distributed rate decision means both RNCs will operate within a common limit.

5.8 Modification Procedures

The OoBTC procedures shall support the following modification mechanisms:

- i) modify Selected Codec (codec type or Active Codec Set)
- ii) modify Available Codec List (reduction of Available Codec)
- iii) mid-call codec negotiation, codec type and available codec list

The specific call flows when such procedures may be required are detailed in Clause 6.

5.8.1 Modification of Selected Codec

In Figure 5.8.1/1 the basic codec modification procedure is shown. The principle is that the request for modification is made from one node through the network. This Figure is an example; the codec modification procedure may be initiated by any node within the call. Each node with an MGW connection indicates to its MGW that a codec modification may occur with a "reserve characteristics" procedure. This prepares the MGW for a bearer modification (based on the bearer requirements of the new codec) and reserves the resources for the new codec. When the far end node is reached and the modification can be accepted, Modify Acknowledgement is returned. If the bearer must be increased then (as shown in the Figure 5.8.1/1, actions 4,7,9,16) each MGW performs the required bearer modification, "modify characteristics" procedure, back to the preceding node prior to the server sending on the request for modification to the succeeding node. If bearer decrease is needed then no change to the bearer shall be made at this stage.

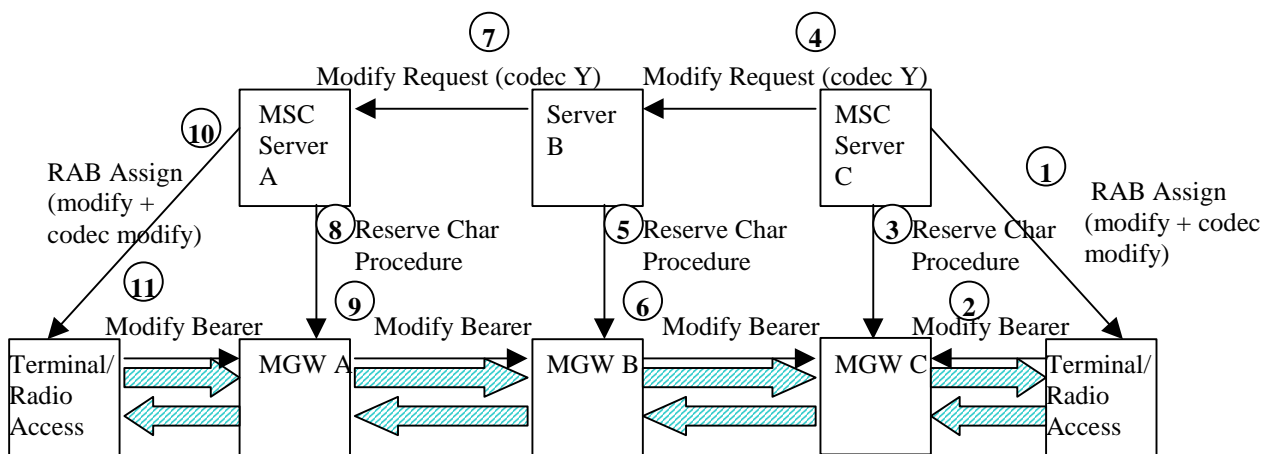

Figure 5.8.1/1: Codec Modification Control Procedures

When the node terminating the Codec Modification receives the Modify request it requests the bearer modification and the codec modification. The MGWs are at this stage only monitoring for new codec type. As shown in Figure 5.8.1/2 the modification of the codec is performed as separate operation for Uplink and Downlink, this ensures that both the codec modification and bearer modification are synchronised.

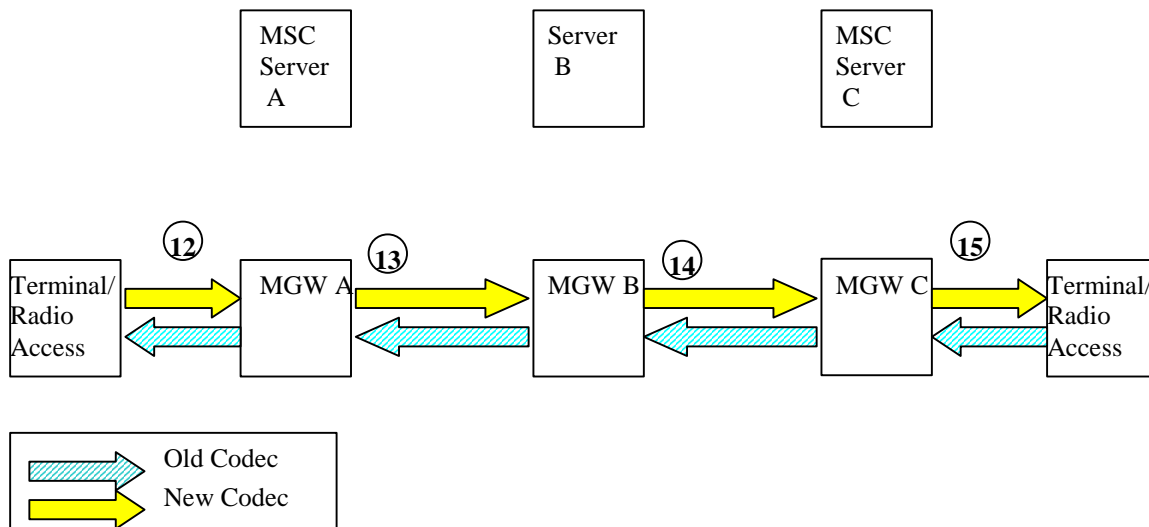

Figure 5.8.1/2: Codec Modification inband procedure

Once the modification of the codec is complete the terminating end replies to the preceding nodes with Modify Ack and indicates to the MGW that the procedure is complete with Conf Char.

If the procedure was unsuccessful then Modify Fail is return to the preceding nodes which then indicate to the MGWs to return to the previous codec selection.

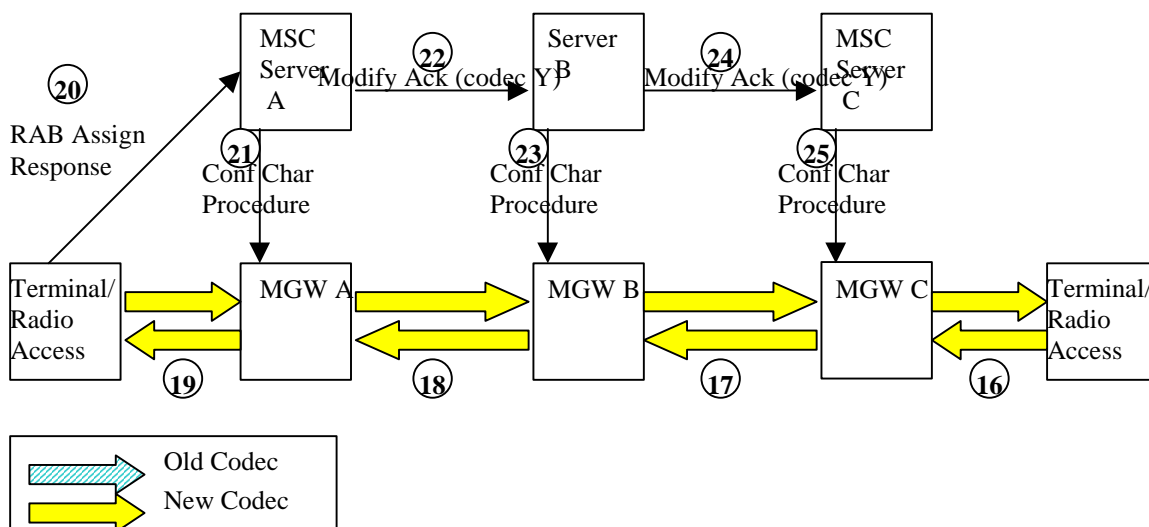

Figure 5.8.1/3: Codec Modification inband procedure and acknowledgement

5.8.2 Modification of Available Codec List

Codec List modification may occur by "puncturing" of codec types or modes from the current Available Codec List. Note this shall not include puncturing of modes from the selected codec, as this would require Selected Codec modification. If a node performs a procedure (e.g. call forwarding) which results in a reduction to the list of Available Codecs then it shall send the new Available Codecs List to all preceding nodes indicating Codec List Modification.

5.8.3 Mid-call Codec negotiation

The selected codec and available codec list can be re-negotiated during the call, when necessary. The node initiating the procedure sends a Supported Codecs List which may contain new codecs and also may not contain previous codecs from the Available Codecs List. If the list no longer contains the Selected Codec then a new codec must be selected. If the current selected codec exists then it should be kept as the preferred codec. The codec negotiation procedure is performed as for set-up, each node may reduce the codec list and pass on the "punctured" list. The last node in the negotiation selects the preferred codec that is left in the remaining Supported Codecs List.

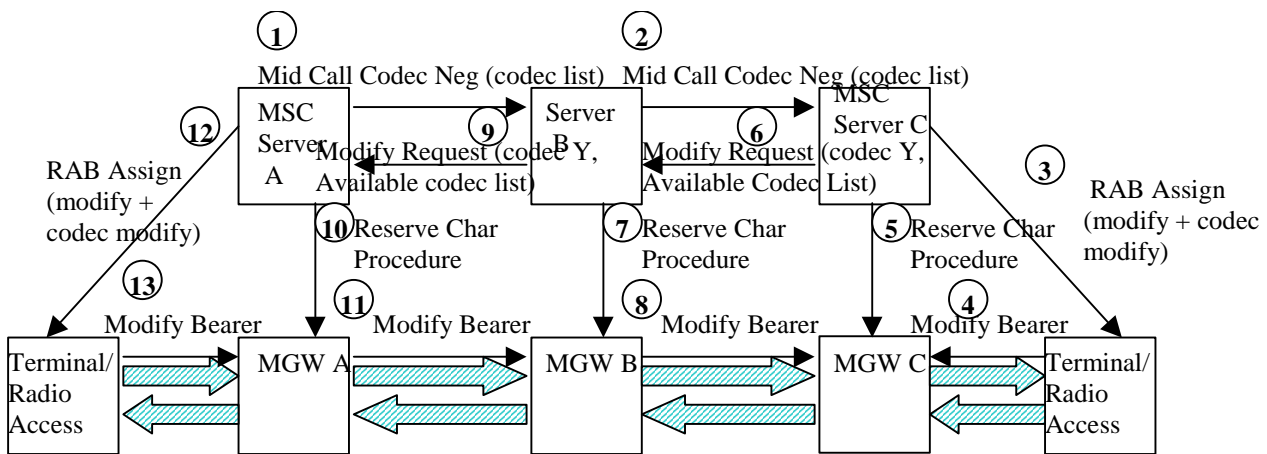

Figure 5.8.3/1: Mid Call Codec Negotiation

The modification to a new Available Codecs List and Selected Codec then follows the procedures described in clause 5.8.1/1 & 5.8.1/2, and 5.8.1/3 initiated by the last node receiving the Mid Call Codec Negotiation procedure.

5.9 DTMF Handling For TrFO Connections

DTMF from the UE is sent via DTAP procedures out-band. For a TrFO call the Originating MSC shall use an out-band DTMF procedure, all CN nodes shall support this procedure in their call control protocol. The out-band DTMF procedure shall also be used when TrFO is not achieved in order that TFO is possible. Insertion of DTMF in the PCM payload can result in the break of the TFO connection.

For terminating calls DTMF may need to be received by the core network (for voice-prompted services, voicemail control procedures etc). If the DTMF is received out-band then out-band procedures shall be maintained in core network.

If the DTMF is received for a TrFO call from an external network inband, in I.366.2 profile or RTP payload type, then the gateway MGW which interworks between Iu Framing and the external framing protocol shall report the DTMF tones via H.248 procedures to its server. The server shall then use out-band procedures to pass the DTMF through the CN. See Figure 5.9/1.

The MGW may also optionally pass DTMF inband where such an option exists for the Nb interface, and is supported by the preceding MGW.

Transcoding to default PCM to send DTMF tones shall be avoided for TrFO connections.

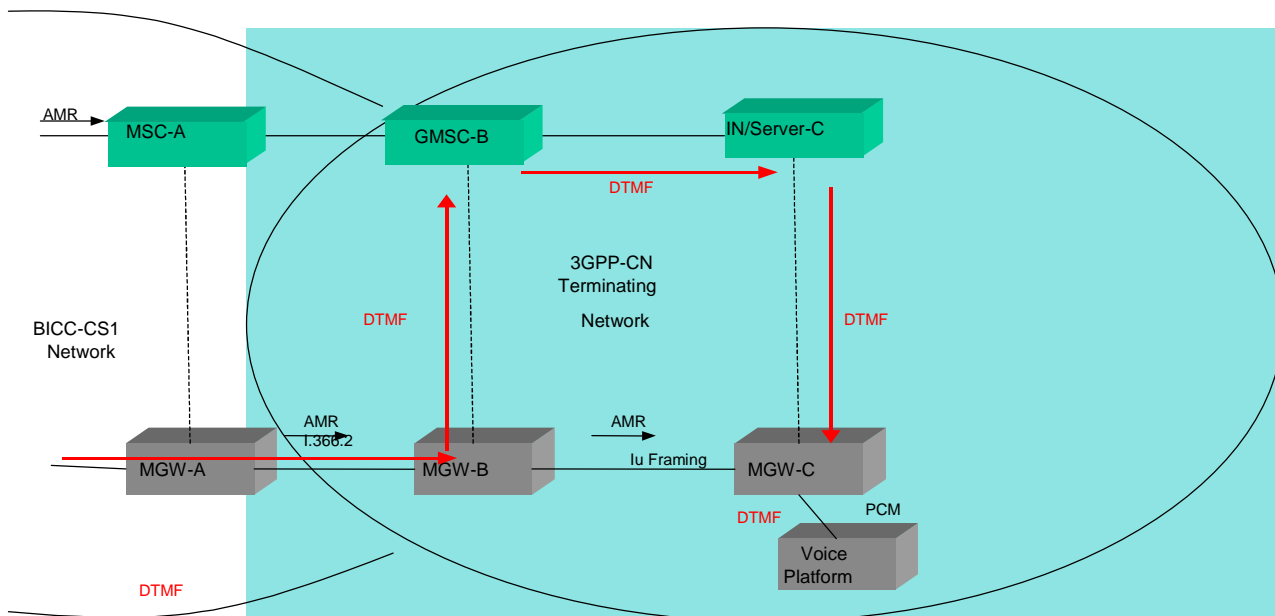

Figure 5.9/1:DTMF received inband from external network

6 Detailed Call Procedures

6.1 Mobile to Mobile TrFO Call Establishment

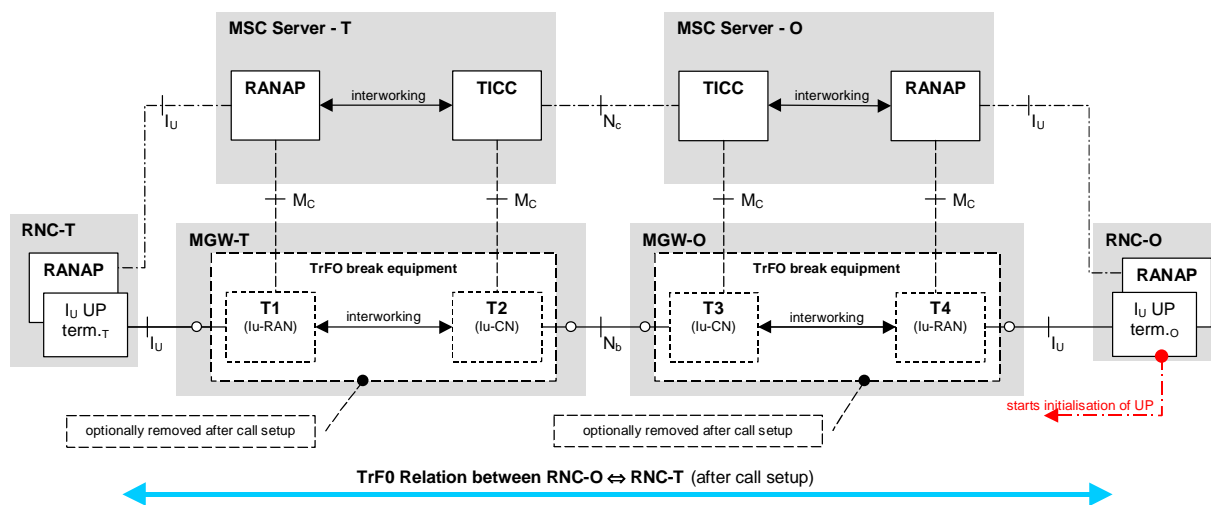

Figure 6.1/1: Configuration during Call Setup of a Mobile to Mobile Call

Following network and protocol entities are involved in the scenario, outlined in Figure 6.1/1:

RNC-T, RNC-O: terminating/originating RNCs.

MSC Server-T, MSC Server-O: MSC Servers, performing service, i.e. codec negotiation.

MGW-T, MGW-O: terminating/originating MGWs with the optional capability to insert/remove so called.

TrFO break equipment (TBEs), i.e. contexts containing an UTRAN- and a CN side I_u Framing termination (**T1 – T4**), inter-working in a distinct manner on control level. [Note: *context* is meant to be the H.248 specific throughout the document]. It is aimed to design protocols for TrFO in a way, that these pieces of HW can be removed after call setup phase to allow to revert to "simple" AAL2 switching in case of ATM transport.

I_U FP term_T, I_U FP term_O: Terminating- and originating-side TrFO peers (I_U Framing terminations in RNC's in Figure 6.1/1).

RANAP, TICC: C-plane protocol incarnations, responsible for codec negotiation, controlling the respective interfaces (I_U, N_C), creating, modifying, removing etc. terminations and contexts.

The final configuration is (at least logically) an end to end TrFO relation between RNC-T and RNC-O with the option to remove the TBEs from the user data path, i.e. to revert to pure AAL2 switching in case of ATM Transport.

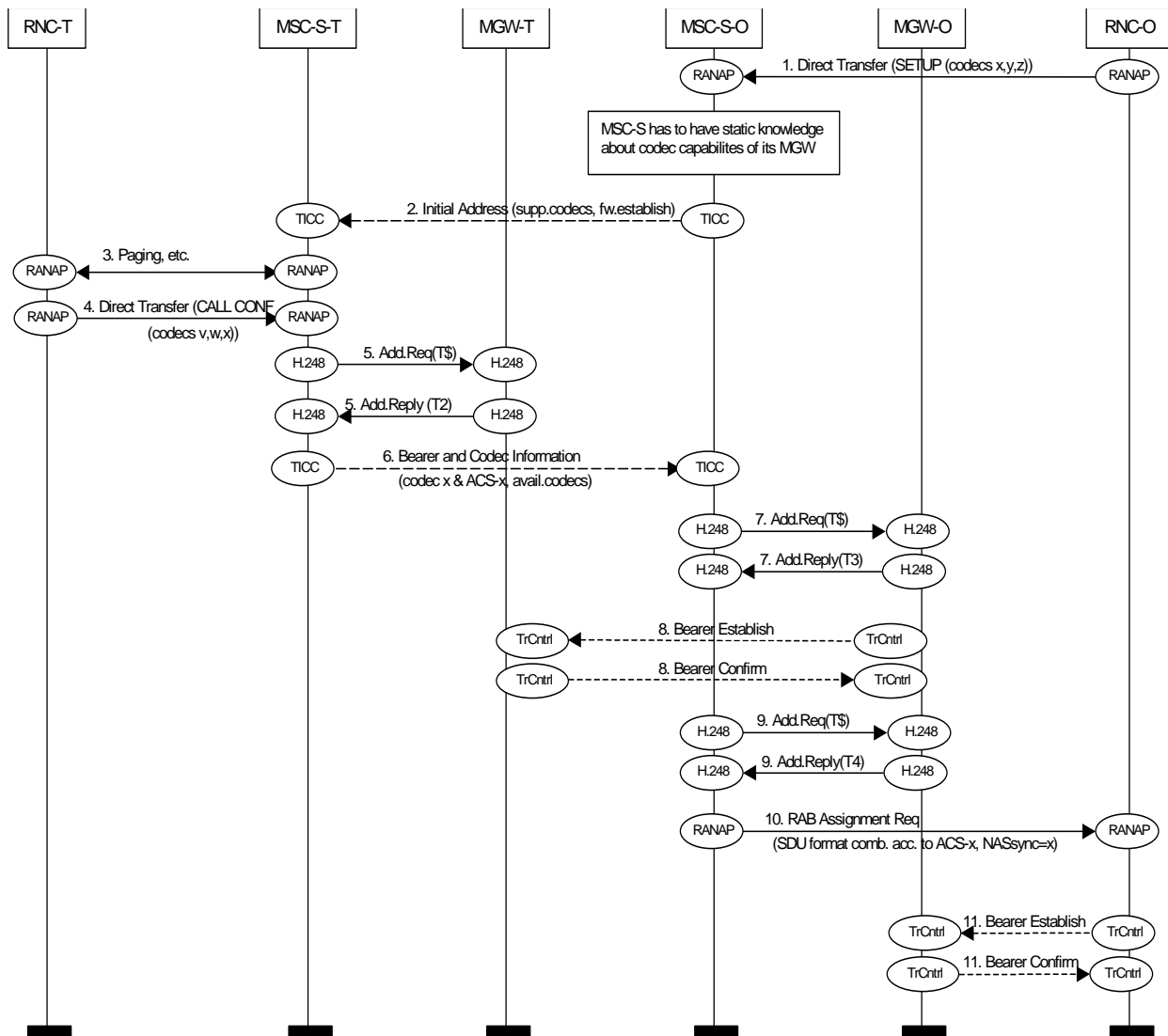

Figure 6.1/2: Call Setup. Mobile to Mobile Call. Message Flow part 1

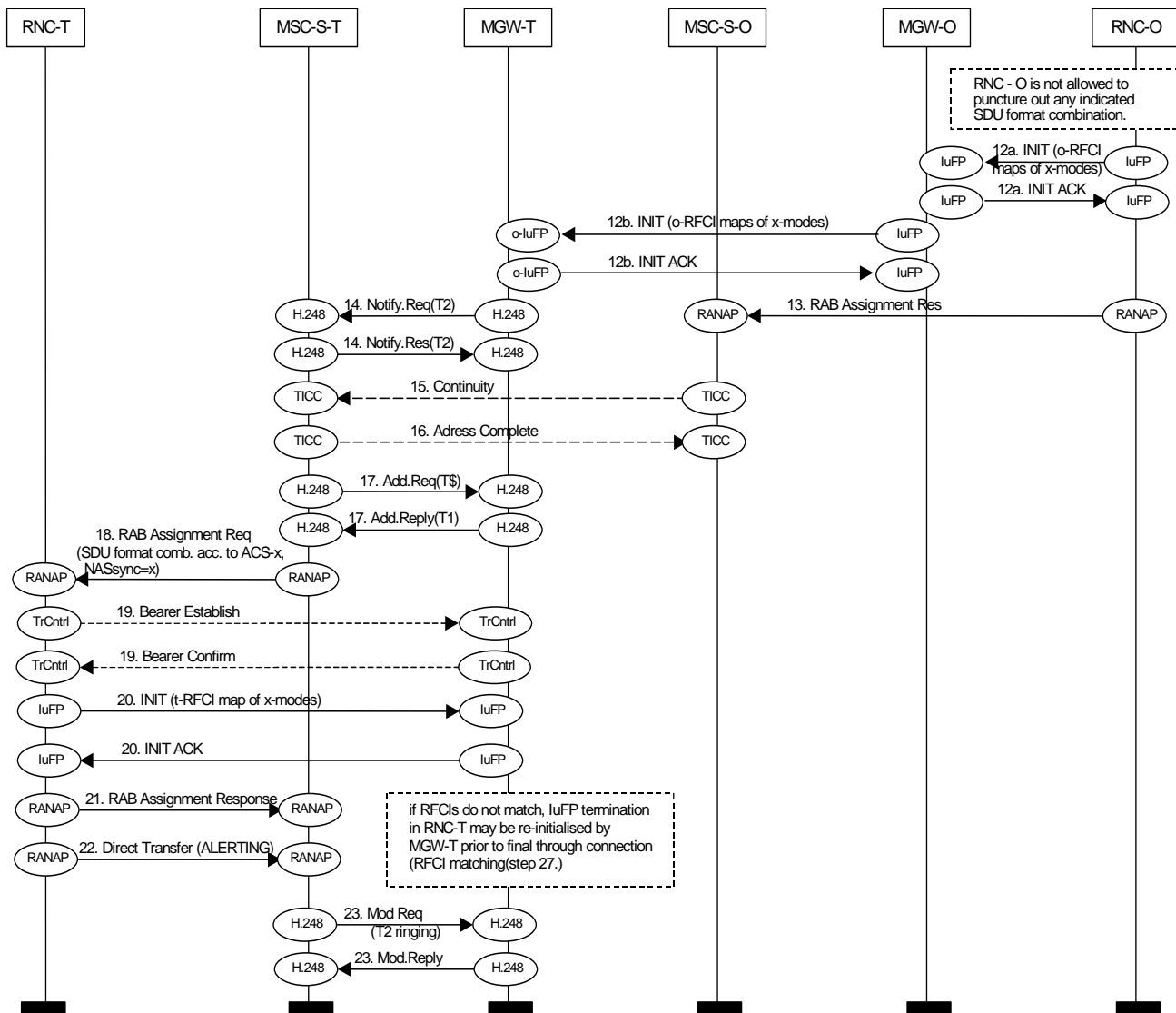

Figure 6.1/3: Call Setup. Mobile to Mobile Call. Message Flow part 2

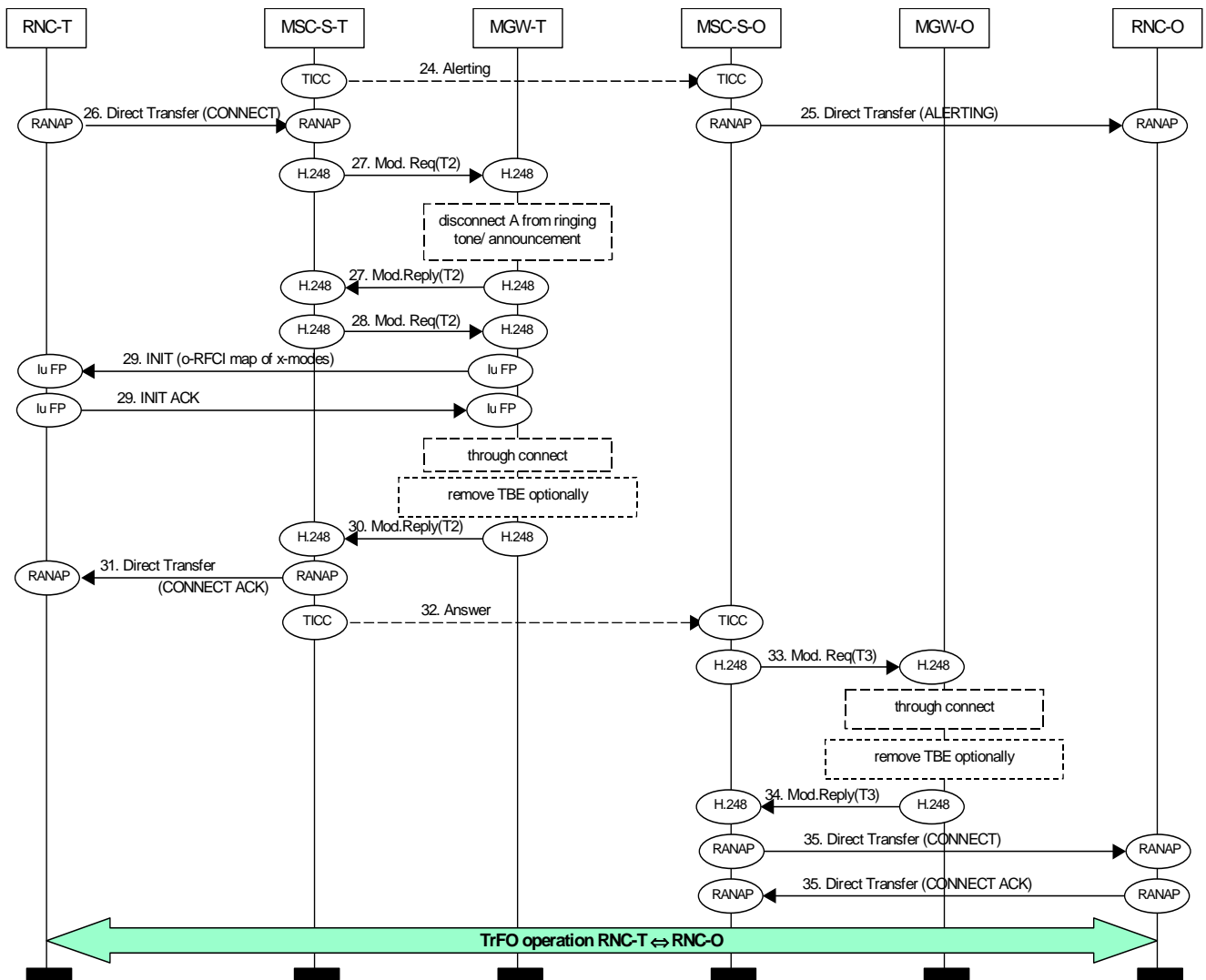

Figure 6.1/4: Call Setup. Mobile to Mobile Call. Message Flow part 3

Codec negotiation

Steps 1. to 6. give the codec negotiation phase. The mobiles inform the network about their capabilities (1. and 4.). Afterwards the MSC-Server performs codec negotiation according to clause 5.6.

Network side bearer establishment

MSC-T/MSC-O shall request seizure of network side bearer terminations with IuFP properties (see steps 5. and 7.). Intermediate CN nodes that may perform certain service interactions (e.g. IN nodes) have to seize terminations with IuFP properties as well.

RAB Assignment

RAN side terminations with IuFP property have to be seized (9. and 17.) before sending RAB Assignment (steps 10. and 18.), that contains RAB parameters according to the selected codec and the negotiated ACS. In addition, the respective NAS synchronisation indicator shall be included.

6.2 SRNS Relocation during TrFO

In order to maintain TrFO connection in SRNS Relocation, procedures specified in [8] and [11] for "Intra-MSC SRNS Relocation" shall be followed. Note that the "Intra-MSC SRNS Relocation" procedure can also be used for relocation between RNC's connected to different 3G MSC's. In this case SCCP Global Title addressing shall be used to signal directly from the Anchor MSC to the drift RNC.

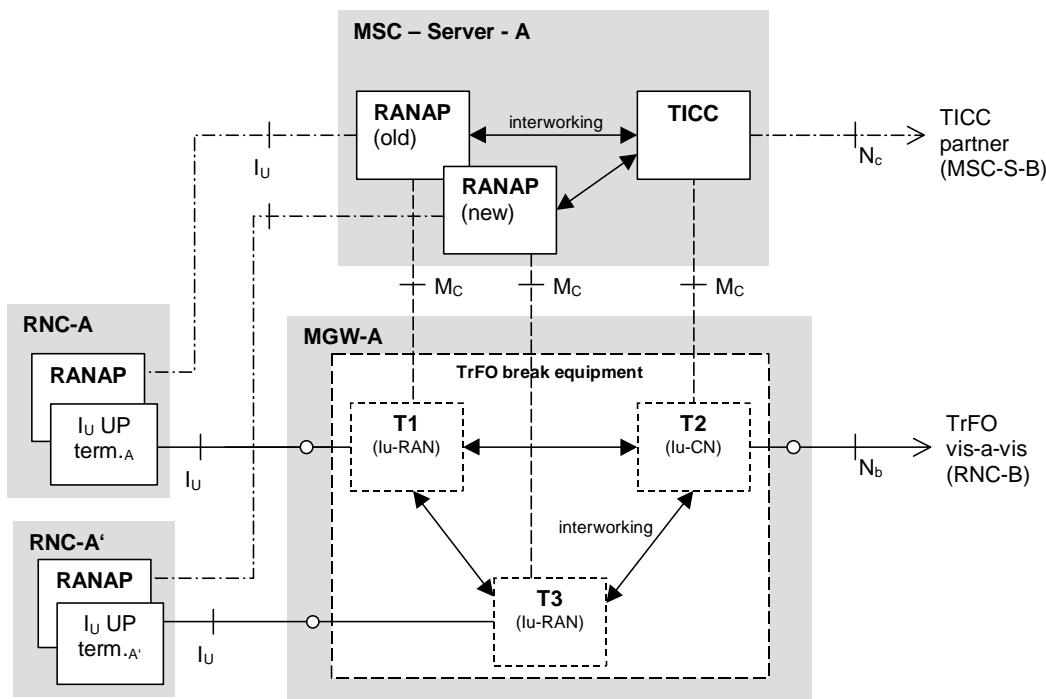

Figure 6.2/1: Configuration during SRNS Relocation

Figure 6.1/1 shows the configuration during relocation. After setting up the new I_U interface (towards RNC-A') until releasing the old one, the original TrFO relation ($A \leftrightarrow B$) and the target TrFO relation ($A' \leftrightarrow B$) exist in parallel. Within the respective context (TBE) interworking between T1, T2 and T3 is necessary:

T3 will perform initialisation towards RNC-A'.

T2 will hide initialisation performed on $I_{U,A'}$ from RNC-B.

If the option to remove the TBE was applied after call setup, the whole context (TBE) needs to be inserted prior to performing SRNS Relocation. Initialisation data need to be available within MGW-A. After Relocation, the context (TBE) may be removed again, i.e. the MGW-A again acts as a pure AAL2 switch.

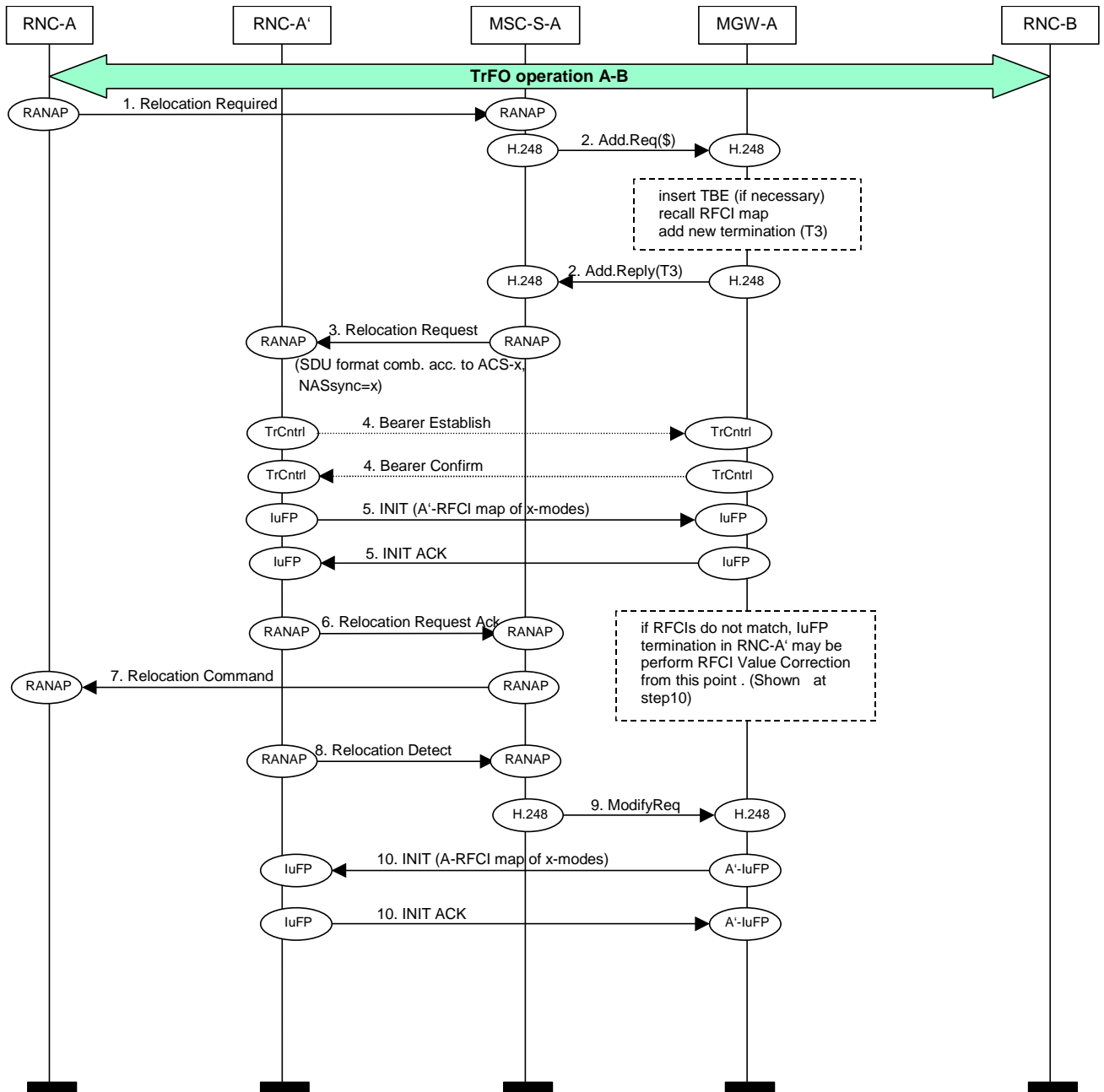

Figure 6.2/2:SRNS Relocation and TrFO. Flow chart part 1

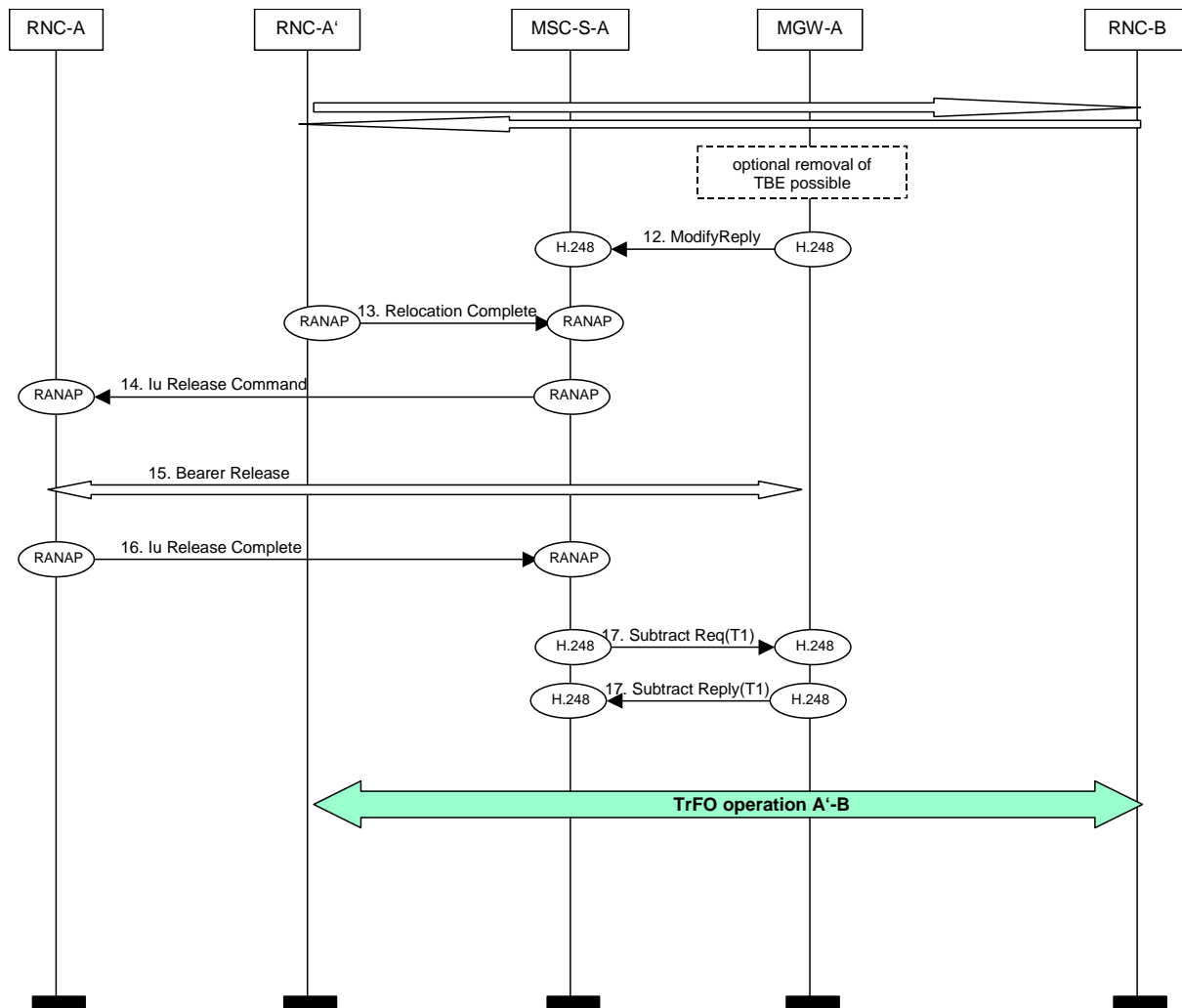

Figure 6.2/3 SRNS Relocation and TrFO. Flow chart part 2

RAB Assignment on the new Iu leg:

A RAN side terminations with IuFP property (T3) has to be added to the already seized call context (step 2.) before sending Relocation Request (4.), that contains all the RAB parameters already applied on the Iu leg towards RNC-A.

UP initialisation

RNC-A' shall accept the requested set of codec modes and is not allowed to puncture out any negotiated mode. The INIT frames shall be according to the RAB parameters received.

At reception of an INIT frame from the new RNC, the termination at MGW-A shall not perform forwarding of the IuFP initialisation. The MGW shall check whether the received RFCI allocations match the stored RFCI allocation. If it does not match, it may re-initialise the IuFP towards RNC-A' at this point in time.

Removal of TrFO Break Equipment (TBE)

If the MGW supports the removal of TBEs, it shall insert the TBE before seizing the additional termination. It may again remove the TBE after performing RFCI matching and through-connection of the new termination and the termination to the far end party.

6.3 IN and Call Forward SS

In some cases, IN services (e.g. voice prompting) are triggered at CC-IN nodes that require the establishment of an UP bearer for tones or announcements to be sent to the calling party. In order to establish this bearer, it is necessary that the CC-IN node temporarily selects one codec from the codec list sent from the initiating node, and informs the initiating node about the selected codec. Afterwards, the call may continue its establishment to the another node, which may not support the selected codec but requests that another one in the list be selected instead.

A similar situation arises with the CFNRy supplementary service. A UP connection needs to be established between the originating and "provisional" terminating CC nodes to enable ringing tones to be sent to the calling party. The type of codec must be agreed prior to the establishment of the bearer connection. Afterwards, the call is redirected to another node that may not support the selected code but requests the selection of another one.

6.3.1 TrFO interworking with SS (VMSC = service interworking node)

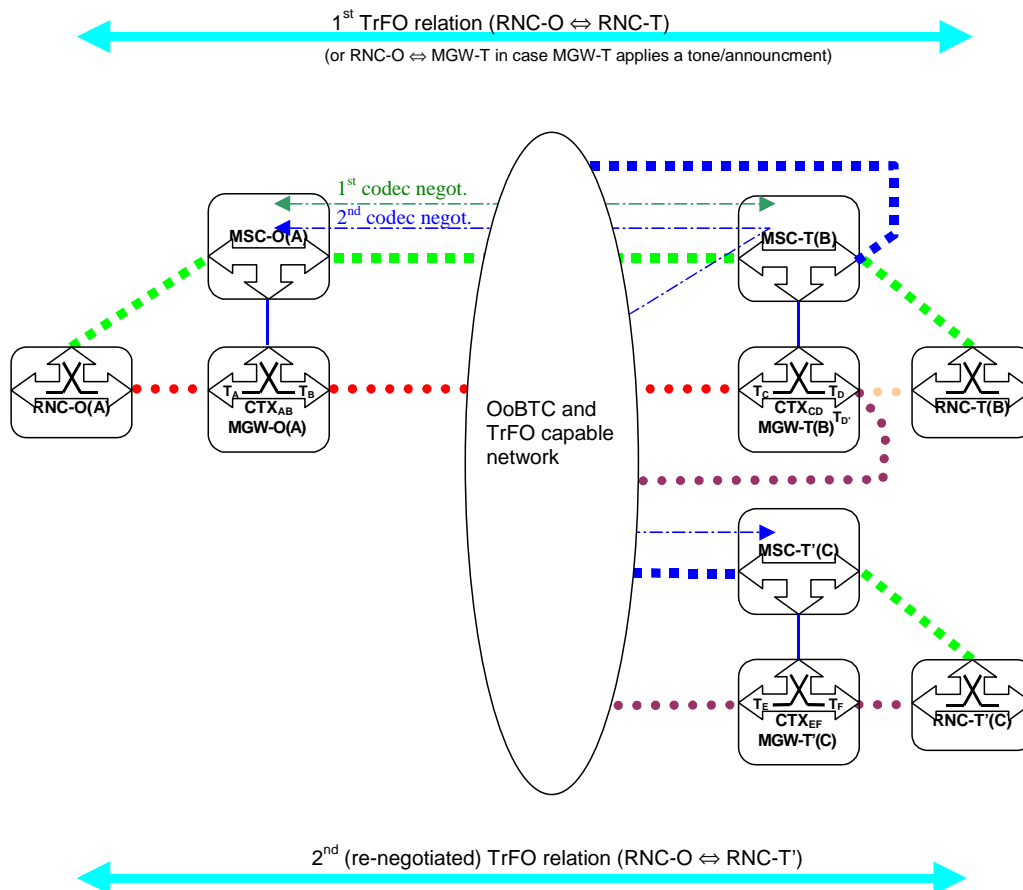

Figure 6.3.1/1. Codec Modification in case of SS interworking

In case of supplementary service interworking, it may become necessary to apply codec modification out of band. Figure 6.3.1/1 shows the network model, that may apply for a certain set of SS's (call deflection (CD), call forwarding on no reply (CFNRy), CF on user determined busy (CFUB), etc.). Common to these scenarios is:

- the service interworking is controlled by the VMSC (this is common to all SSs).
- MSC-T extends the call towards MSC-T' according to the forwarded-/deflected-to-number.

An intermediate TrFO relation will in general already exist between two RNC's (RNC-O and RNC-T in figure 6.3.1/1) before the call is diverted to another node, as the ringing tone was applied in backward direction.

In order to perform codec negotiation with the third node (MSC-T') as well it is necessary to forward the supported codec list from MSC-O. MSC-T' signals back the codec it selected and the available codec list. If the codec negotiation result is different from the previously performed codec negotiation between MSC-O and MSC-T, MSC-O shall be informed. MSC-O shall be able to decide based on the received modified codec type whether In Framing re-initialisation and bearer modification is required. This scenario is depicted in Figure 6.3.1/2 below. If no codec modification has to be applied, MSC-T(B) shall extend the UP initialisation towards MSC-T'(C), i.e. MSC-T(B) shall initialise a termination (TC) with the property Initialisation Procedure = incoming. MSC-T' (C) shall also initialise a termination TC with the property Initialisation Procedure = incoming. Further call handling follows the mobile to mobile call establishment (see clause 6.1).

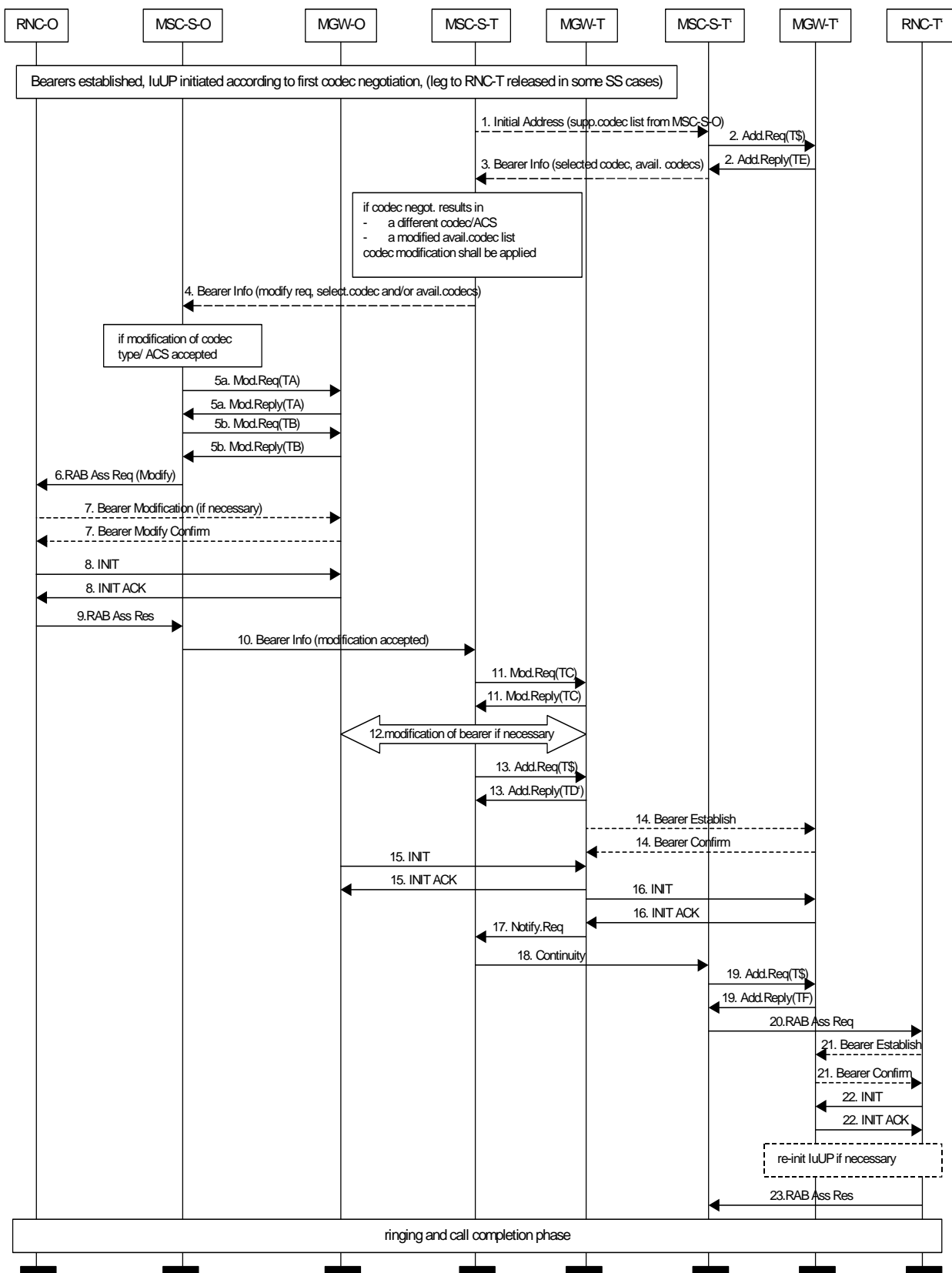

Figure 6.3.1/2: Codec Modification for SS-interworking & UP re-initialisation

6.3.2 IN interworking (VMSC ≠ service interworking node)

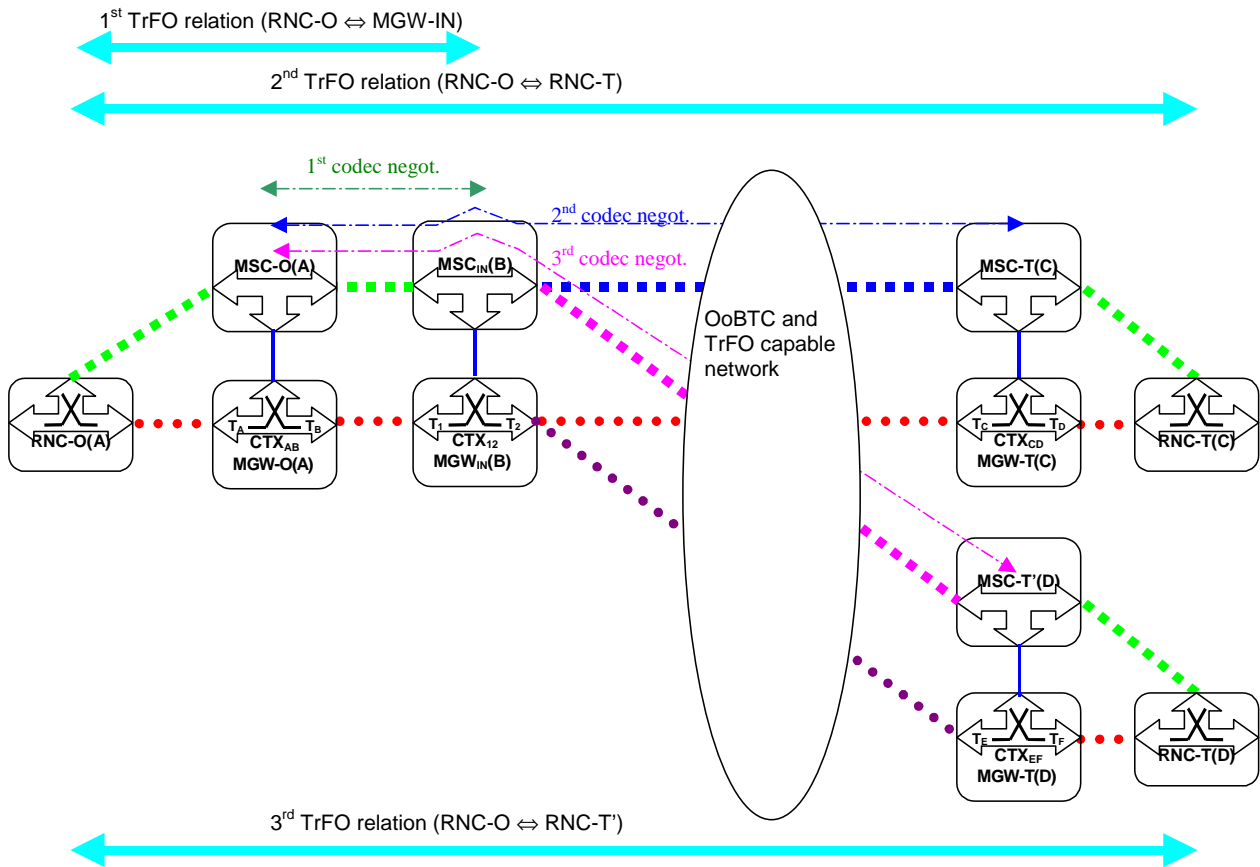

Figure 6.3.2/1. Codec Modification in case of IN interworking

Common to IN interworking scenarios is that service interworking is controlled by an IN service node that is generally not the VMSC.

IN interworking (i.e. in case of a separate IN service node, this is often a Gateway-MSC) may interrupt call establishment and apply an intermediate announcement back to the originating side. This means, that codec negotiation was in fact performed between the IN service node and the MSC-O.

When performing further call establishment, it is necessary to proceed with codec negotiation towards MSC-T. The codec negotiation process shall consider the capabilities of MGW-IN.

IN services, similar to call forwarding SS, are possible. The fact that this service interworking is controlled by an IN service node, may cause, that the leg towards MSC-T has to be released and a new leg towards MSC-T' will be established. Codec negotiation is again necessary from MSC-IN on.

The sequence chart given in figure 6.3.1/2 applies in principle for the 1st and the 2nd negotiation scenarios with following modifications:

- as MSC-IN may be involved in subsequent service interworking again, the capabilities of MGW-IN shall be taken into account during codec negotiation with MSC-T or MSC-T'. This means, that the codec list forwarded to the succeeding nodes is in fact the available codec list of the 1st negotiation.
- For the 3rd negotiation scenario, the leg between MSC_{IN}(B) and MSC-T (C) has to be released and a new leg toward MSC-T'(D) has to be setup.

6.4 Information flow for interaction with Multiparty SS

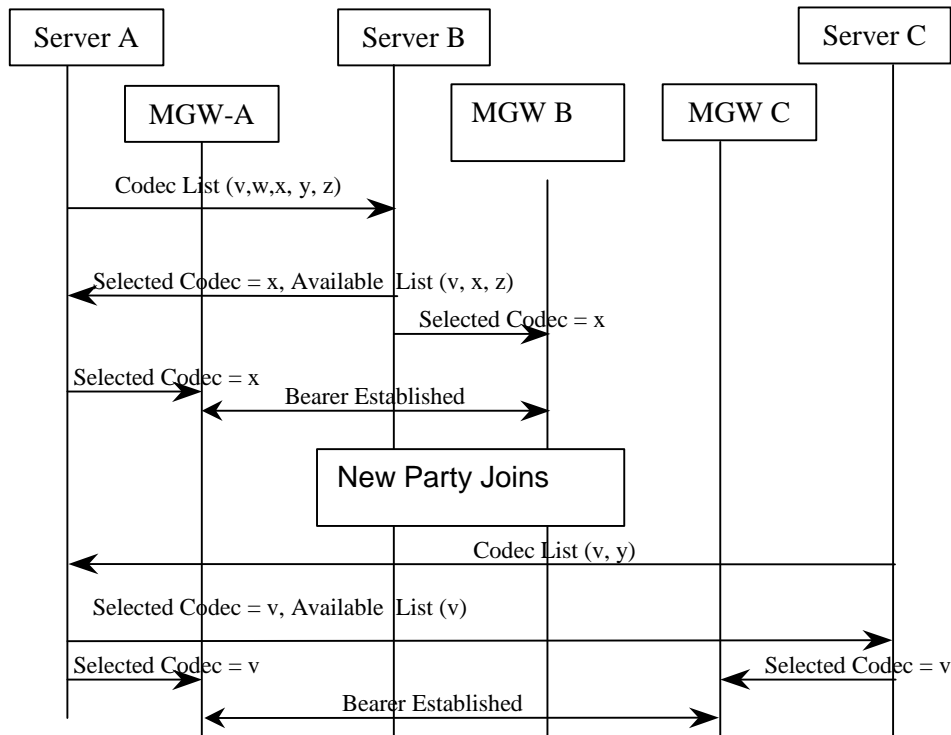

Figure 6.4/1: Multi-party Call

The operation of the MGW for conference calls is implementation dependent. The sequence in Figure 6.4/1 shows three connections to the MGW, where two were configured TrFO and have matching codecs but the third connection could not be made with the same codec type.

The Iu Framing connections for each multi-party call leg shall be terminated in the MGW where the multi-party call is controlled. The MGW shall control each connection independently during the multi-party call.

When the multi-party call is released, if two parties remain in the connection it shall be possible to either revert directly to a TrFO connection if both codecs match or OoBTC procedures could be performed to modify one or both of the codec types to achieve a TrFO connection. However, if the Server does not perform this then the MGW shall continue to resolve the difference in codecs by internal transcoding procedures.

Codec modification procedures may be employed (see clause 5.8.1) if a common codec exists, this is shown in Figure 6.4/2, where codec v is common to all parties.

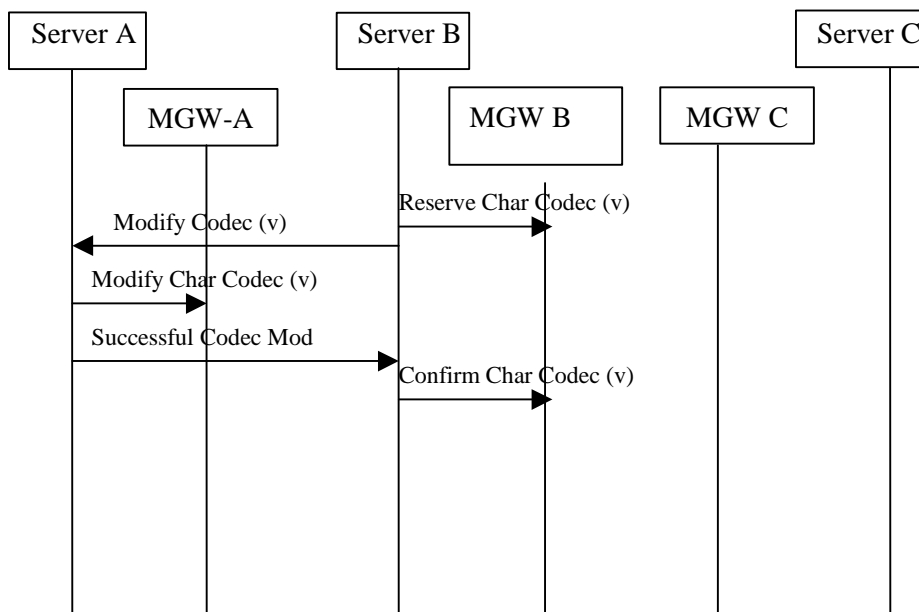

Figure 6.4/2: Multi-party Call, with codec modification

6.5 Information flow for handover from UMTS to GSM after TrFO establishment

Inter-system handover procedures are described at call control level in [11] and details for bearer independent architecture is described in [8]. For TrFO connected UMTS call, when a handover occurs to GSM radio access, by definition the A-interface to the BSC shall be default PCM. Prior to receipt of Handover Detect the Anchor MGW has one leg (A-interface) stream mode as default PCM and two terminations with compressed voice codec properties. It is recommended that after the Handover Complete procedure, the network property is maintained as compressed. Thus the Anchor MGW inserts a "TFO Partner" transcoder. Thus no modification to the compressed bearer to 64k PCM is required. TFO procedures may then ensure that speech quality is maintained by avoiding transcoding.

In the Intra-MS-C case shown in Figure 6.5/1 the MSC controlling the handover has both codec lists for each radio access. The codec negotiation for the UMTS call was performed end to end with UMTS list. If this negotiation resulted in a codec being selected that is also included in the GSM list then at handover the MSC shall indicate this codec as the current speech version to the BSC and TFO can be achieved. If the selected codec is not supported for the GSM radio access but the GSM list contains a codec that is also in the Available Codecs list then the MSC has the option to perform codec modification to ensure TFO can be achieved. The MSC may also perform codec list modification by sending forward the GSM list to update nodes in the network of the change to the Available Codecs List.

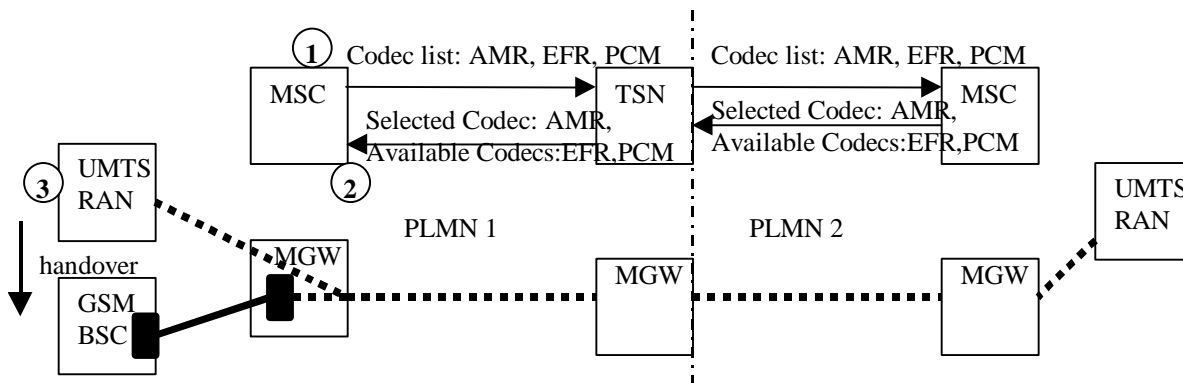

Figure 6.5/1: UMTS to GSM Inter-System Handover

If the Inter-system handover is an inter-MSC handover then the Anchor MSC sends the current speech version and the supported speech versions in the Prepare Handover Request message to the MSC-B. If the current speech version (codec selected for UMTS call) is not included in the GSM list then the MSC-A shall indicate a preferred codec in the current speech version parameter. The speech version for the GSM access that is finally selected by the MSC-B's BSS, is returned to MSC-A in the Prepare Handover Response message. The MSC-A can then decide if codec modification or codec re-negotiation shall be performed as described for the intra-MSC case. The MSC-B shall always assume default PCM across the E-interface, as there is no possibility to perform codec negotiation prior to performing the handover. The connections are shown in Figure 6.5/2.

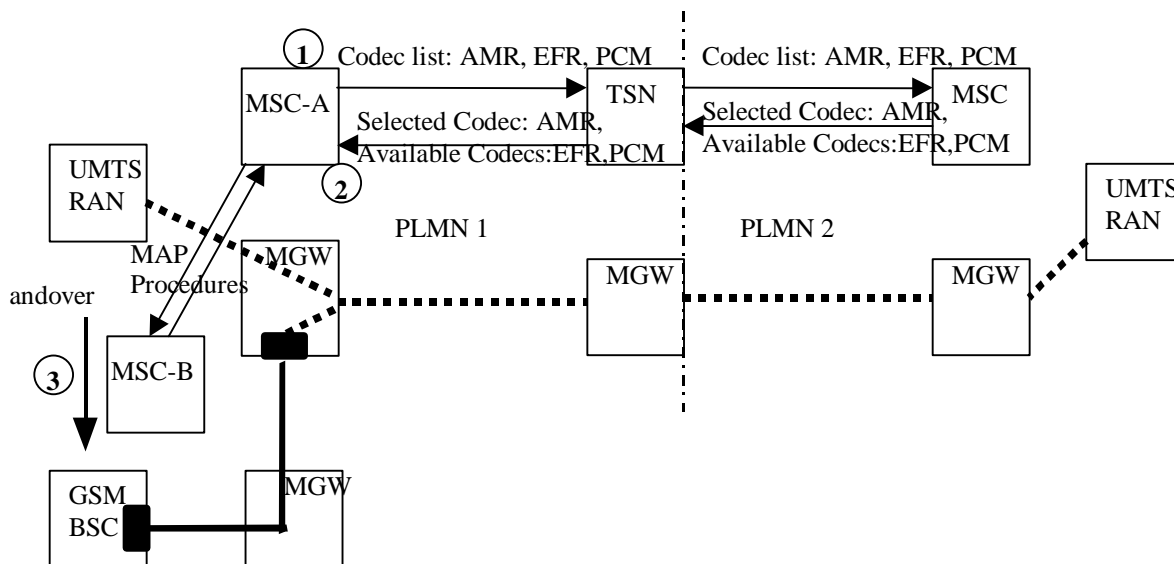

Figure 6.5/2: Inter-MSC, UMTS to GSM handover

6.6 Call Hold/Call Wait

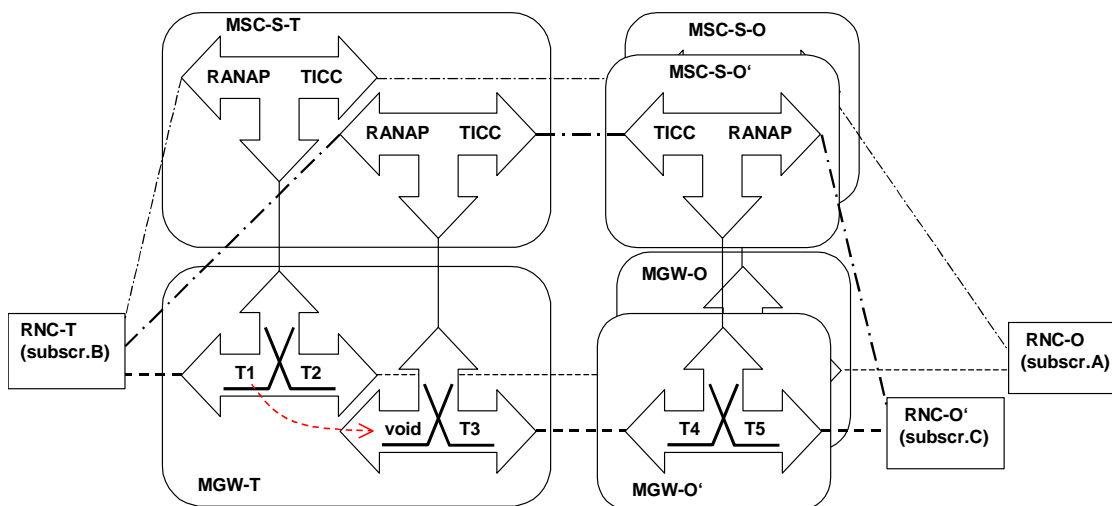

Figure 6.6/1: Configuration during Call Hold/Call Wait scenario

This scenario assumes subscriber C (served by RNC-O') calls subscriber B (served by RNC-T), currently in communication with subscriber A. Subscriber C receives a tone/announcement, applied by terminating side. Then subscriber B puts subscriber A on Hold and A receives an announcement (applied again by terminating side.)

MGW-O has to establish an originating side call context (T4, T5), MGW-T the respective terminating one (T3 only, T1 from subscriber will be moved to it during the scenario), the B party context has to be inserted into path again (if TBE was removed).

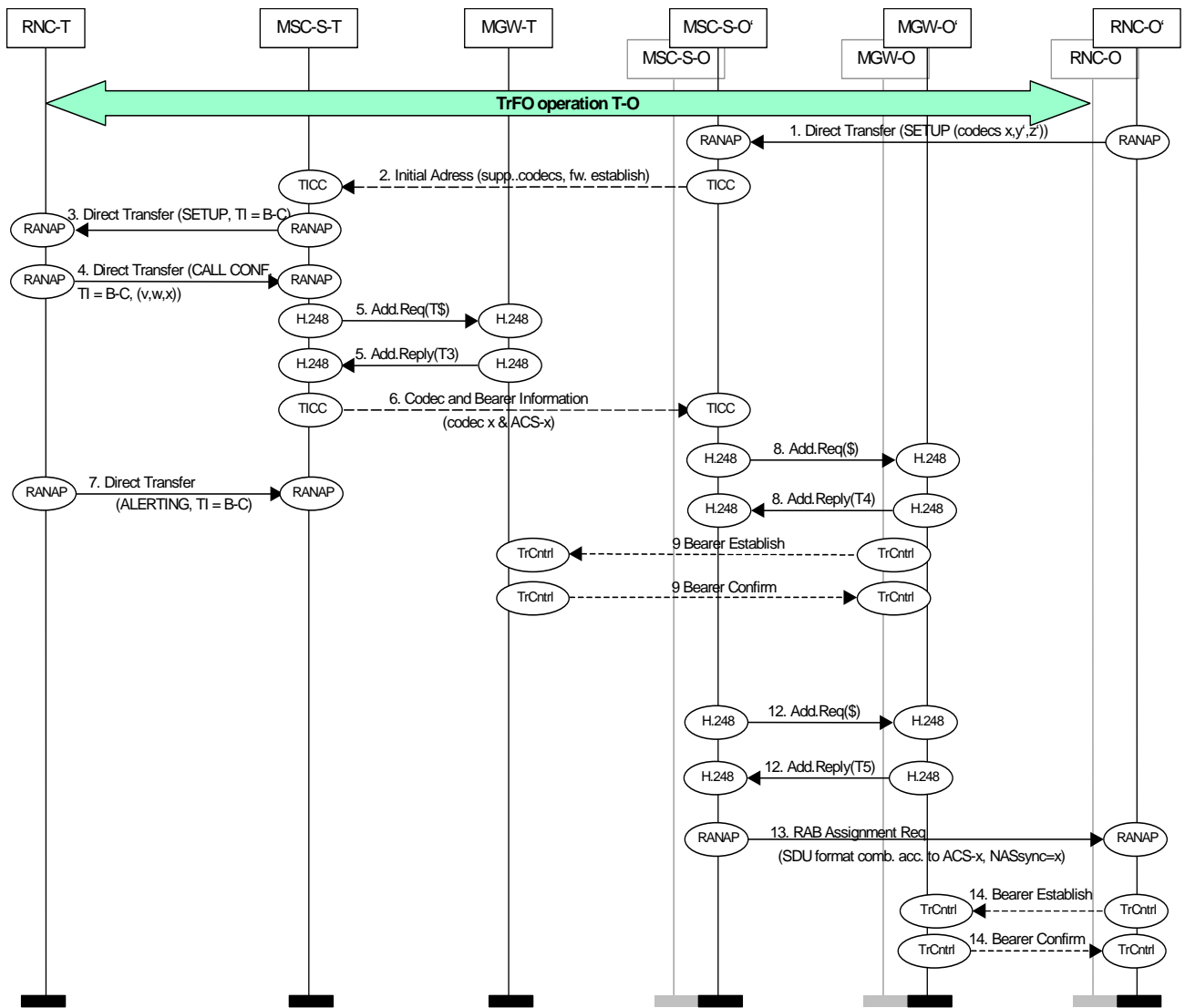

Figure 6.6/2: Call Hold/Call Wait and TrFO. Message flow part 1

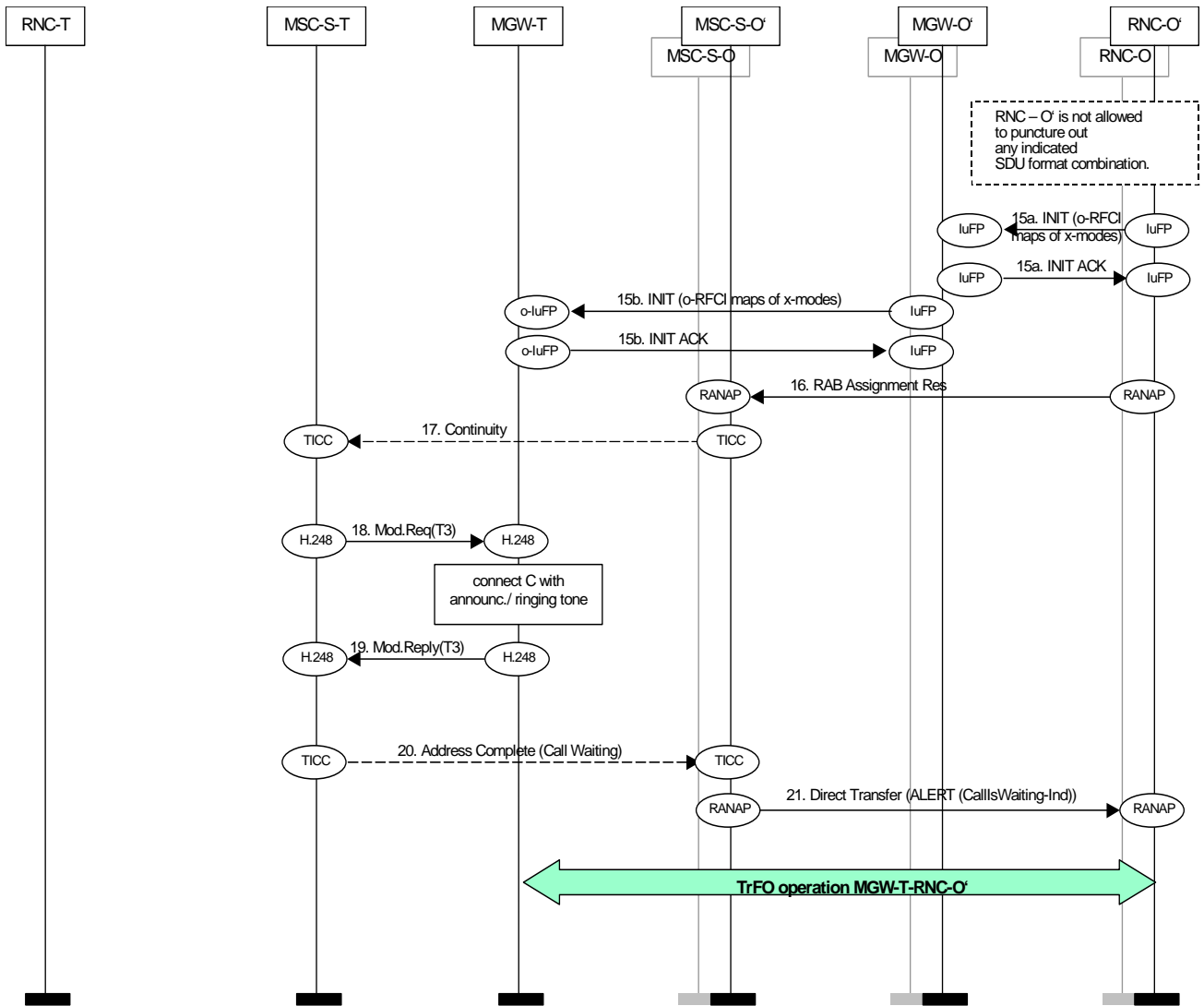

Figure 6.6/3: Call Hold/Call Wait and TrFO. Message flow part 2

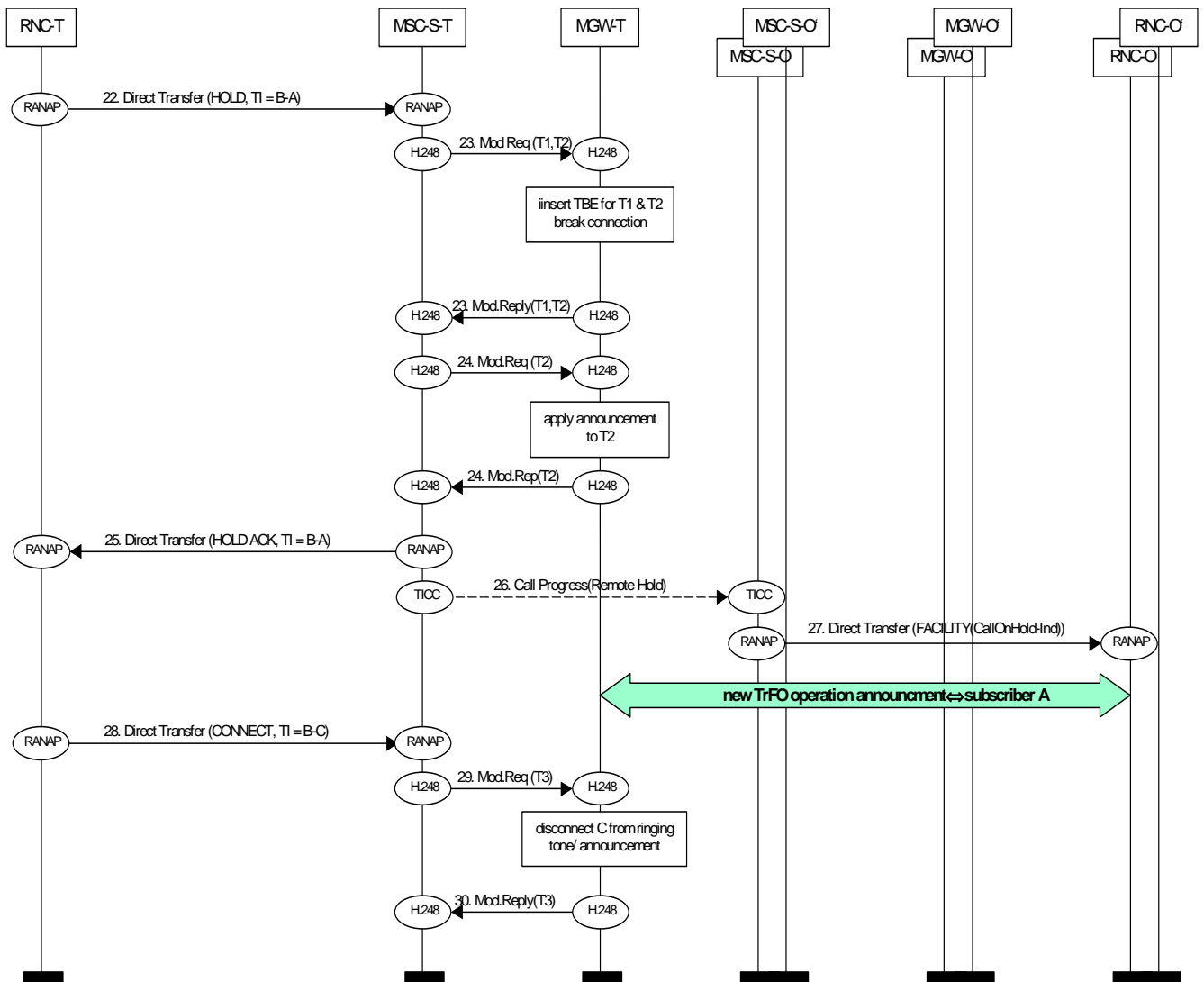

Figure 6.6/4: Call Hold/Call Wait and TrFO. Message flow part 3

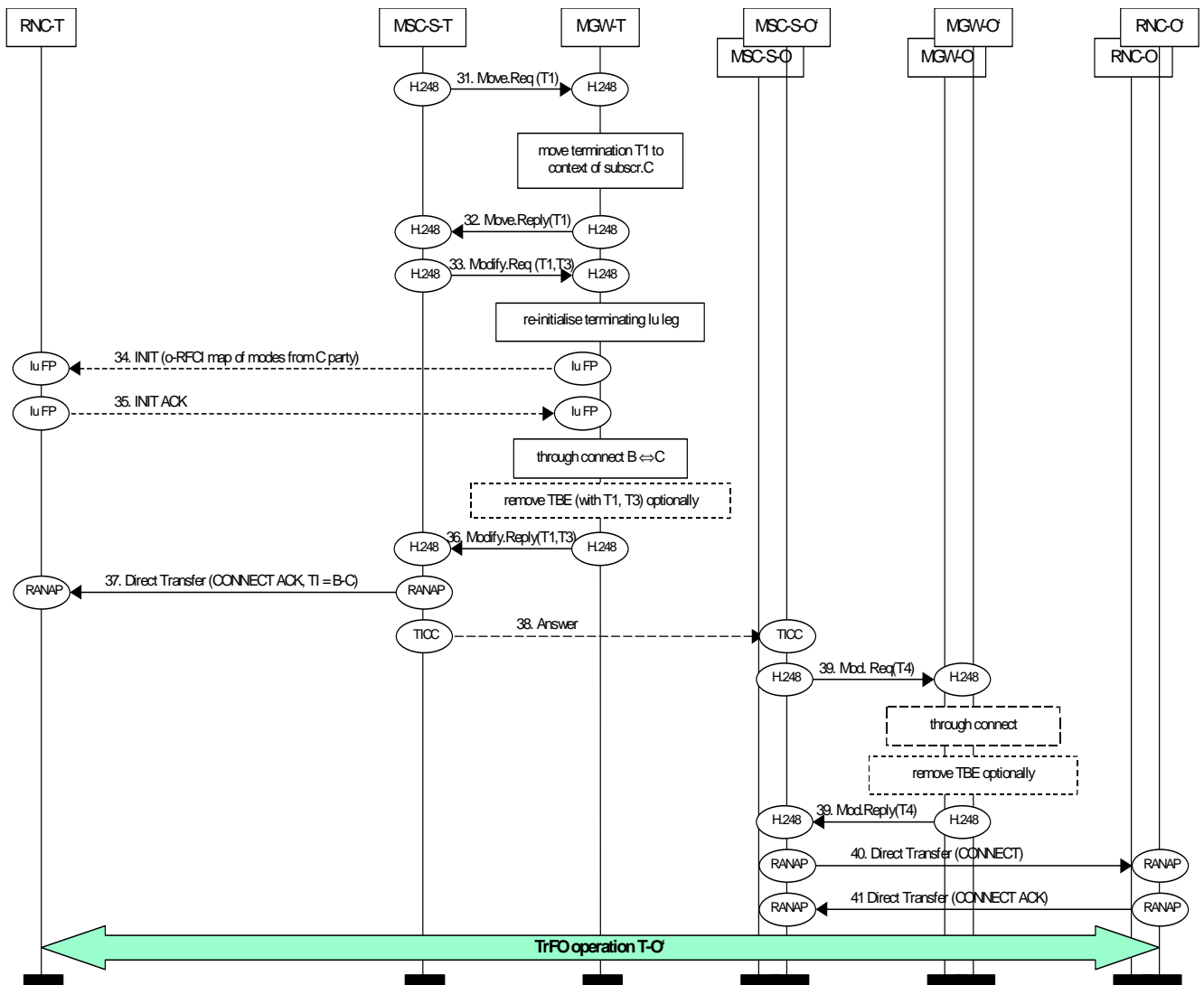

Figure 6.6/5: Call Hold/Call Wait and TrFO. Message flow part 4

6.7 External Network to Mobile TrFO Call Establishment

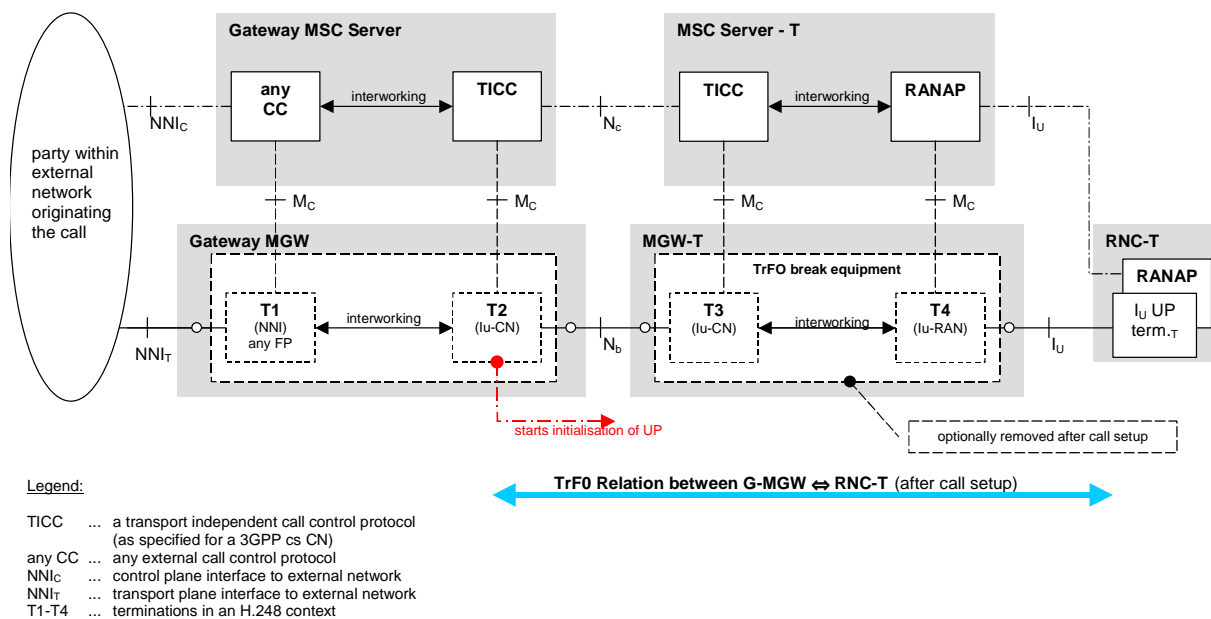

Figure 6.7/1. Configuration during Call Setup of an External Network to Mobile Call

The description of Figure 6.1/1 (Configuration during Call Setup of a Mobile to Mobile Call) within clause 6.1 applies for the network and protocol entities involved in the External Network to Mobile Call scenario with following modifications:

No RNC-O is present – a party served by an external network originates the call instead.

The originating CN nodes are Gateway nodes (Gateway MSC Server/Gateway MGW).

The Gateway MGW call context is no TrFO break equipment in general, i.e. T1 in general do not support the IuFP framing protocol. Appropriate interworking (in some cases transcoding) has to be performed between T1 and T2.

Therefore Figures 6.1/2 to 6.1/4. (the respective message flows for mobile to mobile call setup) apply in principle as well with appropriate modifications outlined below:

Codec negotiation

Step 1. Until 6., that give the codec negotiation phase in Figure 6.1/2, shall be applied with following modifications:

There is no originating UE involved in this negotiation phase

If the preceding node of the Gateway MSC-Server doesn't support OoBTC procedures for compressed voice types, the Gateway MSC-Server shall initiate OoBTC procedures in order to enable transcoders placement at the edge gateway node.

The edge gateway node shall always send the complete list of the codec types and modes it supports for this type of call setup.

UP initialisation

The main difference compared to the Mobile to Mobile call setup is, that the CN side termination of the Gateway MGW (T2 in figure 6.7/1) shall start the initialisation of the IuFP according to the result of the codec negotiation. The forward initialisation principle shall be followed in any setup scenario.

6.8 Mobile to External Network TrFO Call Establishment

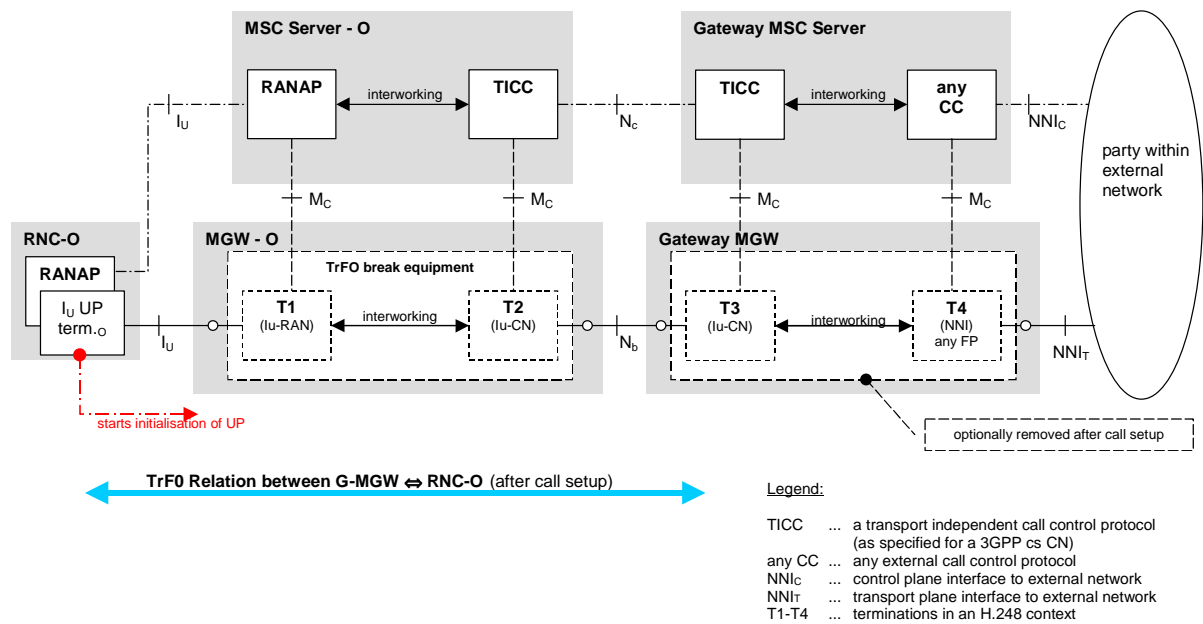

Figure 6.8/1. Configuration during Call Setup of a Mobile to External Network Call

The description of Figure 6.1/1 (Configuration during Call Setup of a Mobile to Mobile Call) within clause 6.1 applies for the network and protocol entities involved in the External Network to Mobile Call scenario with following modifications:

No RNC-T is present – a party served by an external network is the terminating side of the call instead.

The terminating side CN nodes are Gateway nodes (Gateway MSC Server/Gateway MGW).

The Gateway MGW call context is no TrFO break equipment in general, i.e. T4 in general do not support the IuFP framing protocol. Appropriate interworking (in some cases transcoding) has to be performed between T3 and T4.

Therefore Figures 6.1/2 to 6.1/4. (the respective message flows for mobile to mobile call setup) apply in principle as well with appropriate modifications outlined below:

Codec negotiation

Step 1. Until 6., that give the codec negotiation phase in Figure 6.1/2, shall be applied with following modifications:

There is no terminating UE involved in this negotiation phase.

If the succeeding node of the Gateway MSC-Server doesn't support OoBTC procedures for compressed voice types, the Gateway MSC-Server terminates the OoBTC procedures in order to enable transcoders placement at the edge gateway node. When the Gateway MSC-Server terminates the OoBTC procedures it should not select a wideband voice codec to be used in the mobile originating side of the call.

The edge gateway node shall accept the narrowband voice codec MSC-O prefers and shall not puncture out any codec mode.

7 Interactions with supplementary services

7.1 Call Deflection service (GSM 23.072)

In order to apply the confirmation tone to the originating party, the speech insertion procedure described in clause 6.3 is applied.

7.2 Line identification services (GSM 23.081)

7.2.1 Calling Line Identification Presentation (CLIP)

No impact.

7.2.2 Calling Line Identification Restriction (CLIR)

No impact.

7.2.3 Connected Line Identification Presentation (COLP)

No impact.

7.2.4 Connected Line Identification Restriction (COLR)

No impact.

7.3 Call forwarding services (GSM 23.082)

7.3.1 Call Forwarding Unconditional (CFU)

In order to apply the confirmation tone to the originating party, the speech insertion procedure described in clause 6.3 is applied.

7.3.2 Call Forwarding on mobile subscriber Busy (CFB)

In order to apply the confirmation tone to the originating party, the speech insertion procedure described in clause 6.3 is applied.

7.3.3 Call Forwarding on No Reply (CFNRy)

In order to apply the confirmation tone to the originating party, the speech insertion procedure described in clauses 6.3 is applied.

7.3.4 Call Forwarding on mobile subscriber Not Reachable (CFNRc)

In order to apply the confirmation tone to the originating party, the speech insertion procedure described in clauses 6.3 is applied.

7.4 Call wait (GSM 23.083)

In order to apply the notice tone to the interjected party, the speech insertion procedure described in clause 6.4 is applied.

7.5 Call hold (GSM 23.083)

In order to apply the notice tone to the held party, the speech insertion procedure described in clause 6.4 is applied.

7.6 Multiparty (GSM 23.084)

In order to mix calls, the speech insertion procedure described in clause 6.4 is applied.

7.7 Closed user group (GSM 23.085)

No impact.

7.8 Advice of charge (GSM 23.086)

No impact.

7.9 User-to-user signalling (GSM 23.087)

No impact.

7.10 Call barring (GSM 23.088)

7.10.1 Barring of outgoing calls

No impact.

7.10.2 Barring of incoming calls

No impact.

7.11 Explicit Call Transfer (GSM 23.091)

In case that a call A-B is transferred to C by B (A-C as result), A-B may use codec x, A-C may use codec y, the procedure described in clause 6.3 is applied.

7.12 Completion of Calls to Busy Subscriber (3G TS 23.093)

Within CCBS there exists an option for CCBS calls where a bearer can be established before setup in the state "CC-establishment confirmed". If the selected codec after setup is different to the one which was used to establish the bearer, RAB assignment (modify) may be required when RAB parameters are different.

8 Charging

The selected codec shall be included in all the call data records of the call legs involved in out-band codec negotiation belonging to a particular subscriber.

Annex A (informative): Codec Re-negotiation

A node may perform a procedure (e.g. handover) that results in a completely new list from that which was originally negotiated. Assuming that the current Selected Codec is still common (no Selected Codec Modification or re-negotiation) then the node shall send a Re-negotiation Request with the new Supported Codec List. The Supported codec list may then be punctured by nodes in the network in the same way as for the basic Codec Negotiation procedure and a new Available Codecs List returned.

If a node performs a procedure (e.g. handover) that results in both a completely new list and also the need for a new codec then Codec Re-negotiation may be performed with a request for a new codec selection. The procedure is then the same as for an initial codec negotiation.

Annex B (informative): Status of Technical Specification 23.153

Change history							
Date	TSG #	TSG Doc.	CR	Rev	Subject/Comment	Old	New
Sep 1999					First draft prepared by the rapporteur		0.0.0
Oct 1999					2nd draft prepared by the rapporteur (Updated version from Abiko.)	0.0.0	0.1.0
Nov 1999					3rd draft prepared by the rapporteur	0.1.0	0.2.0
Dec 1999					Submitted to CN#06 for information	0.2.0	1.0.0
Feb 2000					4th draft prepared by the rapporteur	1.0.0	1.1.0
Feb 2000					5th draft prepared by the rapporteur (Updated version from Milan.)	1.1.0	1.2.0
Feb 2000					6th draft prepared by the rapporteur (Updated version from Milan.)	1.2.0	1.3.0
Feb 2000					7th draft prepared by the rapporteur (Updated version from Milan.)	1.3.0	1.4.0
Feb 2000					8th draft prepared by the rapporteur (Updated version from Milan.)	1.4.0	1.5.0
Mar 2000					Submitted to TSG CN#07 for approval	1.5.0	2.0.0
Oct 2000					9th draft prepared by the rapporteur (Updated version from Windsor)	2.0.0	2.0.3
Nov 2000					10th draft accepted, input to TrFO workshop #5, Stockholm	2.0.3	2.1.0
Nov 2000					11th draft, workshop #5 interim editors document.	2.1.0	2.1.1
Nov 2000					Final Draft for approval at CN4 WG #5 (Paris)	2.1.1	2.2.0
Nov 2000					Final Clean version for Approval CN TSG (Bangkok)	2.2.0	2.3.0
Dec 2000	CN#10	NP-000653			TS 23.153 Out of Band Transcoder Control - Stage 2 approved as version 4.0.0	2.3.0	4.0.0
Mar 2001	CN#11	NP-010084	001	1	Correct wording of Nb/lu UP protocol	4.0.0	4.1.0
Mar 2001	CN#11	NP-010084	003	1	Alignment of codec modification procedures with current BICC CS2 procedures	4.0.0	4.1.0
Mar 2001	CN#11	NP-010084	004	1	Alignment of codec modification procedures with current BICC CS2 procedures	4.0.0	4.1.0
Mar 2001	CN#11	NP-010084	005	1	Alignment of codec modification procedures with current BICC CS2 procedures	4.0.0	4.1.0
Mar 2001	CN#11	NP-010084	006	1	Interaction with CCBS	4.0.0	4.1.0
Mar 2001	CN#11	NP-010084	007	2	Clause 5.6, establishment of additional calls	4.0.0	4.1.0
Mar 2001	CN#11	NP-010084	009	1	Editorials and minor corrections	4.0.0	4.1.0
Mar 2001	CN#11	NP-010084	012	2	Change of terminology from "Node X" to "MSC Server X"	4.0.0	4.1.0
Mar 2001	CN#11	NP-010084	014	1	Alignment of codec modification procedures with current BICC CS2 procedures	4.0.0	4.1.0
Mar 2001	CN#11	NP-010084	015		Alignment of SRNS Relocation with 3G TS 23.205	4.0.0	4.1.0
Mar 2001	CN#11	NP-010084	016		Inter-MSC Serving Area SRNS Relocation	4.0.0	4.1.0
Mar 2001	CN#11	NP-010084	017	1	General Improvements	4.0.0	4.1.0
Mar 2001	CN#11	NP-010084	020		Reference to Q.2630 in certain diagrams should be bearer independent	4.0.0	4.1.0

Change history							
Date	TSG #	TSG Doc.	CR	Rev	Subject/Comment	Old	New
					independent		
Mar 2001	CN#11	NP-010084	021	1	Initialisation Issues	4.0.0	4.1.0
Mar 2001	CN#11	NP-010084	022	2	Avoiding double description of lu framing package procedure	4.0.0	4.1.0
Jun 2001	CN#12	NP-010284	024	1	Role of MSC server in FP UP version negotiation for TrFO	4.1.0	4.2.0
Jun 2001	CN#12	NP-010297	025		Default Codec For UMTS & GSM dual systems	4.1.0	4.2.0
Sep 2001	CN#13	NP-010457	026		Optional FRCI value Correction	4.2.0	4.3.0
Sep 2001	CN#13	NP-010532	027	1	Default Codec Types For "UMTS only" and "UMTS & GSM dual system" UEs	4.2.0	4.3.0
Sep 2001	CN#13				Editorial clean up	4.2.0	4.3.0
Dec 2001	CN#14	NP-010620	028		Removal of "No Data" SDUs	4.3.0	4.4.0
Dec 2001	CN#14	NP-010620	029		Clarification for Codec Modification in case of SS/IN interworking	4.3.0	4.4.0
Mar 2002	CN#15	NP-020066	030	2	Codec fallback in TrFO Call Establishment to External Network	4.4.0	5.0.0

History

Document history		
V5.0.0	March 2002	Publication