

ETSI TS 123 122 V3.1.0 (2000-01)

Technical Specification

Universal Mobile Telecommunications System (UMTS); NAS Functions related to Mobile Station (MS) in idle mode (3G TS 23.122 version 3.1.0 Release 1999)



Reference

DTS/TSGN-0123122U

Keywords

UMTS

ETSI

Postal address

F-06921 Sophia Antipolis Cedex - FRANCE

Office address

650 Route des Lucioles - Sophia Antipolis
Valbonne - FRANCE
Tel.: +33 4 92 94 42 00 Fax: +33 4 93 65 47 16
Siret N° 348 623 562 00017 - NAF 742 C
Association à but non lucratif enregistrée à la
Sous-Préfecture de Grasse (06) N° 7803/88

Internet

secretariat@etsi.fr
Individual copies of this ETSI deliverable
can be downloaded from
<http://www.etsi.org>
If you find errors in the present document, send your
comment to: editor@etsi.fr

Important notice

This ETSI deliverable may be made available in more than one electronic version or in print. In any case of existing or perceived difference in contents between such versions, the reference version is the Portable Document Format (PDF). In case of dispute, the reference shall be the printing on ETSI printers of the PDF version kept on a specific network drive within ETSI Secretariat.

Copyright Notification

No part may be reproduced except as authorized by written permission.
The copyright and the foregoing restriction extend to reproduction in all media.

© European Telecommunications Standards Institute 2000.
All rights reserved.

Intellectual Property Rights

IPRs essential or potentially essential to the present document may have been declared to ETSI. The information pertaining to these essential IPRs, if any, is publicly available for **ETSI members and non-members**, and can be found in SR 000 314: "*Intellectual Property Rights (IPRs); Essential, or potentially Essential, IPRs notified to ETSI in respect of ETSI standards*", which is available from the ETSI Secretariat. Latest updates are available on the ETSI Web server (<http://www.etsi.org/ipr>).

Pursuant to the ETSI IPR Policy, no investigation, including IPR searches, has been carried out by ETSI. No guarantee can be given as to the existence of other IPRs not referenced in SR 000 314 (or the updates on the ETSI Web server) which are, or may be, or may become, essential to the present document.

Foreword

This Technical Specification (TS) has been produced by the ETSI 3rd Generation Partnership Project (3GPP).

The present document may refer to technical specifications or reports using their 3GPP identities or GSM identities. These should be interpreted as being references to the corresponding ETSI deliverables. The mapping of document identities is as follows:

For 3GPP documents:

3G TS | TR nn.nnn "<title>" (with or without the prefix 3G)

is equivalent to

ETSI TS | TR 1nn nnn "[Digital cellular telecommunications system (Phase 2+) (GSM);] Universal Mobile Telecommunications System; <title>

For GSM document identities of type "GSM xx.yy", e.g. GSM 01.04, the corresponding ETSI document identity may be found in the Cross Reference List on www.etsi.org/key

Contents

Foreword	5
1 Scope.....	6
1.1 Normative references.....	6
1.2 Definitions and abbreviations	7
2 General description of idle mode.....	9
3 Requirements and technical solutions.....	10
3.1 PLMN selection and roaming	10
3.2 Regional provision of service	10
3.3 Borders between registration areas	11
3.4 Access control.....	11
3.4.1 Access control	11
3.4.2 Forbidden LA for regional provision of service.....	11
3.5 No suitable cell (limited service state).....	11
3.6 CTS fixed part selection (GSM only).....	12
4 Overall process structure	12
4.1 Process goal	12
4.2 States description	12
4.3 List of states.....	12
4.3.1 List of states for the PLMN selection process.....	12
4.3.1.1 List of states for automatic mode (figure 2a).....	12
4.3.1.2 List of states for manual mode (figure 2b)	12
4.3.2 List of states for location updating (figure 3).....	13
4.3.3 List of states for location registration (figure 3).....	13
4.4 PLMN selection process	14
4.4.1 Introduction	14
4.4.2 Registration on a PLMN	14
4.4.3 PLMN selection	14
4.4.3.1 At switch-on or recovery from lack of coverage	14
4.4.3.1.1 Automatic Network Selection Mode Procedure	14
4.4.3.1.2 Manual Network Selection Mode Procedure	15
4.4.3.1.3 GPRS Network Selection Mode Procedure	15
4.4.3.2 User reselection	16
4.4.3.2.1 Automatic Network Reselection Mode.....	16
4.4.3.2.2 Manual Network ReSelection	17
4.4.3.2.3 Semi Automatic Network ReSelection	17
4.4.3.3 In VPLMN of home country.....	17
4.4.3.4 Determination of Support of GPRS Services.....	18
4.4.3.5 Investigation Scan for higher prioritized PLMN	18
4.4.4 Abnormal cases	18
4.4.5 Roaming not allowed in this LA	18
4.5 Location registration process	19
4.5.1 General	19
4.5.2 Initiation of Location Registration	19
4.5.3 Periodic Location Registration.....	20
4.5.4 IMSI attach/detach operation	20
4.6 Service indication	21
4.7 Pageability of the mobile subscriber.....	21
4.8 MM Restart Procedure.....	21

5 Tables and Figures 22

Annex A (normative): HPLMN Matching Criteria..... 28

Annex B (informative): Change history 32

History..... 33

Foreword

This Technical Specification has been produced by the 3GPP.

This TS specifies functions related to Mobile Station (MS) in idle mode and within the 3GPP system.

The contents of the present document are subject to continuing work within the TSG and may change following formal TSG approval. Should the TSG modify the contents of this TS, it will be re-released by the TSG with an identifying change of release date and an increase in version number as follows:

Version 3.y.z

where:

- x the first digit:
 - 1 presented to TSG for information;
 - 2 presented to TSG for approval;
 - 3 Indicates TSG approved document under change control.
- y the second digit is incremented for all changes of substance, i.e. technical enhancements, corrections, updates, etc.
- z the third digit is incremented when editorial only changes have been incorporated in the specification;

1 Scope

Text to be added.

1.1 Normative references

The following documents contain provisions which, through reference in this text, constitute provisions of the present document.

- References are either specific (identified by date of publication, edition number, version number, etc.) or non-specific.
- For a specific reference, subsequent revisions do not apply.
- For a non-specific reference, the latest version applies.
- A non-specific reference to an ETS shall also be taken to refer to later versions published as an EN with the same number.
- For this Release 1998 document, references to GSM documents are for Release 1998 versions (version 7.x.y).

- [1] GSM 01.04: "Digital cellular telecommunications system (Phase 2+); Abbreviations and acronyms".
- [2] GSM 02.01: "Digital cellular telecommunications system (Phase 2+); Principles of telecommunications services supported by a GSM Public Land Mobile Network (PLMN)".
- [3] GSM 02.02: "Digital cellular telecommunication system (Phase 2+); Bearer Services (BS) supported by a GSM Public Land Mobile Network (PLMN)".
- [4] GSM 02.03: "Digital cellular telecommunications system (Phase 2+); Teleservices supported by a GSM Public Land Mobile Network (PLMN)".
- [5] GSM 02.04: "Digital cellular telecommunications system (Phase 2+); General on supplementary services".
- [6] GSM 02.06: "Digital cellular telecommunications system (Phase 2+); Types of Mobile Stations (MS)".
- [7] GSM 02.07: "Digital cellular telecommunications system (Phase 2+); Mobile Station (MS) features".
- [8] GSM 02.09: "Digital cellular telecommunications system (Phase 2+); Security aspects".
- [9] GSM 02.11: "Digital cellular telecommunications system (Phase 2+); Service accessibility".
- [10] GSM 02.16: "Digital cellular telecommunications system (Phase 2+); International Mobile station Equipment Identities (IMEI)".
- [11] GSM 02.17: "Digital cellular telecommunications system (Phase 2+); Subscriber identity modules Functional characteristics".
- [12] GSM 02.24: "Digital cellular telecommunications system (Phase 2+); Description of Charge Advice Information (CAI)".
- [13] GSM 02.30: "Digital cellular telecommunications system (Phase 2+); Man-Machine Interface (MMI) of the Mobile Station (MS)".
- [14] GSM 02.40: "Digital cellular telecommunications system (Phase 2+); Procedures for call progress indications".
- [15] GSM 02.41: "Digital cellular telecommunications system (Phase 2+); Operator determined barring".

- [16] GSM 02.81: "Digital cellular telecommunications system (Phase 2+); Line identification supplementary services - Stage 1".
- [17] GSM 02.82: "Digital cellular telecommunications system (Phase 2+); Call Forwarding (CF) supplementary services - Stage 1".
- [18] GSM 02.83: "Digital cellular telecommunications system (Phase 2+); Call Waiting (CW) and Call Hold (HOLD) supplementary services - Stage 1".
- [19] GSM 02.84: "Digital cellular telecommunications system (Phase 2+); MultiParty (MPTY) supplementary services - Stage 1".
- [20] GSM 02.85: "Digital cellular telecommunications system (Phase 2+); Closed User Group (CUG) supplementary services - Stage 1".
- [21] GSM 02.86: "Digital cellular telecommunications system (Phase 2+); Advice of Charge (AoC) supplementary services - Stage 1".
- [22] GSM 02.88: "Digital cellular telecommunications system (Phase 2+); Call Barring (CB) supplementary services - Stage 1".
- [23] GSM 04.08: "Digital cellular telecommunications system (Phase 2+); Mobile radio interface layer 3 specification".
- [24] GSM 05.02: "Digital cellular telecommunications system (Phase 2+); Multiplexing and multiple access on the radio path".
- [25] GSM 05.08: "Digital cellular telecommunications system (Phase 2+); Radio subsystem link control".
- [26] GSM 02.60: "Digital cellular telecommunications system (Phase 2+); General Packet Radio Service (GPRS); Service description Stage 1".
- [27] GSM 03.60: "Digital cellular telecommunications system (Phase 2+); General Packet Radio Service (GPRS); Service description Stage 2".
- [28] GSM 03.64: "Digital cellular telecommunications system (Phase 2+); General Packet Radio Service (GPRS); Overall description of the GPRS Radio Interface; Stage 2".
- [29] GSM 02.56: "Digital cellular telecommunications system (Phase 2+); GSM Cordless Telephony System (CTS); Service Description; Stage 1
- [30] GSM 03.56: "Digital cellular telecommunications system (Phase 2+); GSM Cordless Telephony System (CTS); CTS Architecture Description; Stage 2

1.2 Definitions and abbreviations

Abbreviations used in this TS are listed in GSM 01.04.

Home PLMN This is a PLMN where the MCC and MNC of the PLMN identity match the MCC and MNC of the IMSI. Matching criteria are defined in Annex A.

Selected PLMN This is the PLMN that has been selected according to subclause 3.1, either manually or automatically.

Available PLMN This is a PLMN where the MS has found a cell that satisfies conditions (ii) and (iv) of subclause 3.2.1 in TS 03.22.

Registered PLMN (RPLMN) This is the PLMN on which certain LR outcomes have occurred (see table 1).

Allowable PLMN This is a PLMN which is not in the list of forbidden PLMNs in the MS.

Visited PLMN of home country This is a PLMN, different from the home PLMN, where the MCC part of the PLMN identity is the same as the MCC of the IMSI.

- Registration** This is the process of camping on a cell of the PLMN and doing any necessary LRs.
- Camped on a cell** The MS (ME if there is no SIM) has completed the cell selection/reselection process and has chosen a cell from which it plans to receive all available services. Note that the services may be limited, and that the PLMN may not be aware of the existence of the MS (ME) within the chosen cell.
- Current serving cell** This is the cell on which the MS is camped.
- Suitable Cell** This is a cell on which an MS may camp. It must satisfy criteria defined in TS 03.22 subclause 3.2.1.
- Acceptable Cell** This is a cell that the MS may camp on to make emergency calls. It must satisfy criteria defined in TS 03.22 sub clause 3.2.2.
- GPRS MS** An MS capable of GPRS services is a GPRS MS.
- CTS MS** An MS capable of CTS services is a CTS MS.
- Location Registration (LR)** An MS which is IMSI attached to non-GPRS services only performs location registration by the Location Updating procedure. A GPRS MS which is IMSI attached to GPRS services or to GPRS and non-GPRS services performs location registration by the Routing Area Update procedure only when in a network of network operation mode I. Both procedures are performed independently by the GPRS MS when it is IMSI attached to GPRS and non-GPRS services in a network of network operation mode II or III (see GSM 03.60).
- Localised Service Area (LSA)** A localised service area consists of a cell or a number of cells. The cells constituting a LSA may not necessarily provide contiguous coverage.
- Network Type** The network type associated with HPLMN or a PLMN on the PLMN selector (see GSM 11.11). The MS uses this information to determine what type of radio carrier to search for when attempting to select a specific PLMN. A PLMN may support more than one network type.
- SoLSA exclusive access** Cells on which normal camping is allowed only for MS with Localised Service Area (LSA) subscription.
- Registration Area** A registration area is an area in which mobile stations may roam without a need to perform location registration. The registration area corresponds to location area (LA) for performing location updating procedure and it corresponds to routing area for performing the routing area update procedure.

The PLMN to which a cell belongs (PLMN identity) is given in the system information transmitted on the BCCH (MCC + MNC part of LAI).

- In GSM,...** Indicates this paragraph applies only to GSM System. For multi system case this is determined by the current serving radio access network.
- In UMTS,...** Indicates this paragraph applies only to UMTS System. For multi system case this is determined by the current serving radio access network.
- (GSM only)** Indicates this section or paragraph applies only to GSM system. For multi system case this is determined by the current serving radio access network.
- (UMTS only)** Indicates this section or paragraph applies only to UMTS system. For multi system case this is determined by the current serving radio access network.
- SIM** Subscriber Identity Module (see TS GSM 02.17). This specification makes no distinction between SIM and USIM.
- MS** Mobile Station. This specification makes no distinction between MS and UE.

2 General description of idle mode

When an MS is switched on, it attempts to make contact with a GSM public land mobile network (PLMN). The particular PLMN to be contacted may be selected either automatically or manually. The MS looks for a suitable cell of the chosen PLMN and chooses that cell to provide available services, and tunes to its control channel. This choosing is known as "camping on the cell". The MS will then register its presence in the registration area of the chosen cell if necessary, by means of a location registration (LR), GPRS attach or IMSI attach procedure. If the MS loses coverage of a cell, it reselects onto the most suitable alternative cell of the selected PLMN and camps on that cell. If the new cell is in a different registration area, an LR request is performed. If the MS loses coverage of a PLMN, either a new PLMN is selected automatically, or an indication of which PLMNs are available is given to the user, so that a manual selection can be made.

Registration is not performed by MSs only capable of services which need no registration for example GPRS services PTM-M or PTP anonymous access.

The purpose of camping on a cell in idle mode is threefold:

- a) It enables the MS to receive system information from the PLMN.
- b) If the MS wishes to initiate a call, it can do this by initially accessing the network on the control channel of the cell on which it is camped (with the exceptions defined in TS 03.22 subclauses 3.5.3 and 3.5.4).
- c) If the PLMN receives a call for the MS, it knows (in most cases) the registration area of the cell in which the MS is camped. It can then send a "paging" message for the MS on control channels of all the cells in the registration area. The MS will then receive the paging message because it is tuned to the control channel of a cell in that registration area, and the MS can respond on that control channel.

If the MS is unable to find a suitable cell to camp on, or the SIM is not inserted, or if it receives certain responses to an LR request (e.g., "illegal MS"), it attempts to camp on a cell irrespective of the PLMN identity, and enters a "limited service" state in which it can only attempt to make emergency calls.

If the CTS MS is in CTS mode only or in automatic mode with CTS preferred, it will start by attempting to find a CTS fixed part on which it is enrolled

The idle mode tasks can be subdivided into 4 processes:

- PLMN selection;
- Cell selection and reselection;
- Location registration;
- CTS fixed part selection.

To make this initial CTS fixed part selection, the MS shall be enrolled on at least one fixed part.

The relationship between these processes is illustrated in figure 1. The states and state transitions within each process are shown in figures 2 to 4.

3 Requirements and technical solutions

The following subclauses list the main requirements of idle mode operation and give an outline of the technical solution.

3.1 PLMN selection and roaming

The MS normally operates on its home PLMN (HPLMN). However a visited PLMN (VPLMN) may be selected, e.g., if the MS loses coverage. There are two mandatory modes for PLMN selection:

- i) Automatic mode - This mode utilizes a list of PLMNs in priority order. The highest priority PLMN which is available and allowable is selected.
- ii) Manual mode - Here the MS indicates to the user which PLMNs are available. Only when the user makes a manual selection does the MS try to obtain normal service on the VPLMN.

Optionally, an MS may support additional modes for PLMN selection:

Mobiles supporting GPRS:

- iii) GPRS mode - This mode prioritises PLMNs which support GPRS services, but is otherwise similar to the Automatic mode (above).

There are two cases:

- International Roaming - This is where the MS receives service on a PLMN of a different country than that of the HPLMN.
- National Roaming - This is where the MS receives service from a PLMN of the same country as that of the HPLMN, either anywhere or on a regional basis. The MS makes a periodic search for the HPLMN while national roaming.

To prevent repeated attempts to have roaming service on a not allowed LA, when the MS is informed that an LA is forbidden, the LA is added to a list of "forbidden LAs for roaming" which is stored in the MS. This list is deleted when the MS is switched off or when the SIM is removed. Such area restrictions are always valid for complete location areas independent of possible subdivision into GPRS routing areas. The structure of the routing area identifier (GSM 03.03) supports area restriction on LA basis.

If a "PLMN not allowed" message is received by an MS in response to an LR request from a VPLMN, that VPLMN is added to a list of "forbidden PLMNs" in the SIM and thereafter that VPLMN will not be accessed by the MS when in automatic mode. A PLMN is removed from the "forbidden" list if, after a subsequent manual selection of that PLMN, there is a successful LR. This list is retained when the MS is switched off or the SIM is removed. The HPLMN shall not be stored on the list of "forbidden PLMNs".

A ME not supporting SoLSA may consider a cell with the escape PLMN code (see GSM 03.73) to be a part of a PLMN belonging to the list of "forbidden PLMNs".

Optionally the ME may store in its memory an extension of the forbidden PLMN list. The contents of the extension of the list shall be deleted when the MS is switched off or the SIM is removed.

3.2 Regional provision of service

An MS may have a "regionally restricted service" where it can only obtain service on certain LAs. If such an MS attempts to camp on a cell of an LA for which it does not have service entitlement, when it does an LR request, it will receive an "LA not allowed" message. In this case:

- The MS stores the forbidden LA identity (LAI) in a list of "forbidden LAIs for regional provision of service", to prevent repeated access attempts on a cell of the forbidden LA. This list is deleted when the MS is switched off or the SIM is removed. If the MS cannot find a suitable cell, the MS performs the PLMN selection procedure starting at subclause 4.4.3.1 A or B

In GSM, a cell may be reserved for SoLSA exclusive access (see GSM 04.08 and 04.60). An MS is only allowed to camp normally on such a cell if it has a Localised Service Area subscription to the cell. Other MS may camp for limited service.

NOTE: In GSM, in a SoLSA exclusive cell the MCC+MNC code is replaced by a unique escape PLMN code (see GSM 03.73), not assigned to any PLMN, in SI3 and SI4. An MS not supporting SoLSA may request for location update to an exclusive access cell. In this case the location attempt is rejected with the cause "PLMN not allowed" and the escape PLMN code is added to the list of the "forbidden PLMNs".

3.3 Borders between registration areas

If the MS is moving in a border area between registration areas, it might repeatedly change between cells of different registration areas. Each change of registration area would require an LR, which would cause a heavy signalling load and increase the risk of a paging message being lost. The access stratum shall provide a mechanism to limit this effect.

3.4 Access control

3.4.1 Access control

Due to problems in certain areas, Network Operators may decide to restrict access from some MSs (e.g., in case of congestion), and for this reason an access control mechanism shall be provided.

3.4.2 Forbidden LA for regional provision of service

When the MS is camped on a cell, the LA of which belongs to the list of forbidden LA for regional provision of service, the MS is not allowed to initiate establishment of a CM connection except for an emergency call; it may respond to paging. Also, the MS is not allowed to request GPRS services when camped on a cell of a LA of which belongs to the list of forbidden LA.

3.5 No suitable cell (limited service state)

There are a number of situations in which the MS is unable to obtain normal service from a PLMN. These include:

- a) Failure to find a suitable cell of the selected PLMN;
- b) No SIM in the MS;
- c) A "PLMN not allowed" response to an LR;
- d) An "illegal MS", "illegal ME" or "IMSI unknown in HLR" response to an LR; (Any SIM in the ME is then considered "invalid".)
- e) A "GPRS not allowed" response to an LR of a GPRS MS attached to GPRS services only. (The cell selection state of GPRS MSs attached to GPRS and non-GPRS depends on the outcome of the location updating.)

(In automatic PLMN selection mode, events (a), (c) and (e) would normally cause a new PLMN selection, but even here, the situation may arise when no PLMNs are available and allowable for use).

Under any of these conditions, the MS attempts to camp on an acceptable cell, irrespective of its PLMN identity, so that emergency calls can be made if necessary. When in the limited service state with a valid SIM, the MS shall search for available and allowable PLMNs in the manner described in subclause 4.4.3.1 and when indicated in the SIM also as described in subclause 4.4.3.4. No LR requests are made until a valid SIM is present and either a suitable cell is found or a manual network reselection is performed. In the limited service state the presence of the MS need not be known to the PLMN on whose cell it has camped.

There are also other conditions under which only emergency calls may be made. These are shown in table 2.

3.6 CTS fixed part selection (GSM only)

In CTS mode only or in automatic mode with CTS preferred, the CTS MS normally operates on a CTS fixed part on which the mobile station is already enrolled. If the CTS MS loses CTS coverage in these modes, it shall attempt periodically to select again a CTS fixed part.

To select a CTS fixed part, the CTS MS shall listen to the CTSBCH frequencies of all the fixed parts on which the MS is currently enrolled.

If the CTS MS is moving in a border area between one area with CTS coverage and one without it, it might repeatedly require CTS attachments and LU on the PLMN. To prevent this, the criteria C1_CTS and C2_CTS (defined in GSM 05.08 subclause 11.1) are used. To attach to a CTS FP, the C1_CTS criterion shall be greater than zero. When the C2_CTS criterion falls below zero, the CTS MS shall consider itself to be no more under CTS coverage.

4 Overall process structure

4.1 Process goal

The aim of the idle mode processes is to ensure that the registered PLMN is the selected PLMN.

4.2 States description

Each of the processes of PLMN selection, cell selection and location registration can be described by a set of states. The overall state of the mobile is thus a composite of the states of the three processes. In some cases, an event which causes a change of state in one process may trigger a change of state in another process, e.g., camping on a cell in a new registration area triggers an LR request. The relationship between the processes is illustrated in figure 1.

The states in which the MS may be, for each of the processes, are described below and illustrated in figures 2 to 4. For many of the states, a fuller description can be found in other GSM Technical Specifications, and a reference to the GSM Technical Specification and the relevant section within it, are given after the state description.

In the event of any conflict between the diagrams and the text in this ETS, the text takes precedence.

4.3 List of states

4.3.1 List of states for the PLMN selection process

4.3.1.1 List of states for automatic mode (figure 2a)

- A1 Trying RPLMN - The MS is trying to perform a Location Registration on the registered PLMN.
- A2 On PLMN - The MS has successfully registered on a PLMN.
- A3 Trying PLMN - The MS is trying to register on a PLMN in the ordered list of PLMNs.
- A4 Wait for PLMNs to appear - There are no allowable and available PLMNs at present and the MS is waiting for one to appear.
- A5 HPLMN search in progress - The MS is trying to find if the HPLMN is available.
- A6 No SIM - There is no SIM in the MS, or certain LR responses have been received.

4.3.1.2 List of states for manual mode (figure 2b)

- M1 Trying registered PLMN - The MS is trying to perform a Location Registration on the registered PLMN.

M2	On PLMN - The MS has successfully registered on a PLMN.
M3	Not on PLMN - The MS has failed to register on the selected PLMN.
M4	Trying PLMN - The MS is trying to register on a user selected PLMN.
M5	No SIM - There is no SIM in the MS, or certain LR responses have been received.

4.3.2 List of states for location updating (figure 3)

The states are entered depending on responses to location update (LU) requests.

4.3.3 List of states for location registration (figure 3)

The states are entered depending on responses to location registration (LR) requests. Independent update states exist for GPRS and for non-GPRS operation in MSs capable of GPRS and non-GPRS services.

L1	Updated - The MS enters this state if an LR request is accepted. The update status is set to "updated". The GPRS and the non-GPRS update state of a MS may enter "updated" as a result of combined signalling or as a result of individual signalling depending on the capabilities of the network.
L2	<p>Idle, No IMSI - The MS enters this state if an LR request is rejected with cause:</p> <ul style="list-style-type: none"> a) IMSI unknown in HLR; b) illegal ME; c) illegal MS; d) GPRS not allowed; <p>or if there is no SIM. All update states of a MS enter this state regardless whether received by individual or combined signalling for events b) and c). Event a) results in "Roaming not allowed" for the non-GPRS update state only. Event a) has no influence on the GPRS update state. Event d) results in "Roaming not allowed" for the GPRS update state only. Event d) has no influence on the non-GPRS update state.</p> <p>If a SIM is present, the non-GPRS update status of the SIM is set to "Roaming not allowed" for events a), b) and c).</p>
L3	<p>Roaming not allowed - The MS enters this state if it receives an LU reject message with the cause:</p> <ul style="list-style-type: none"> a) PLMN not allowed; b) Location area not allowed; c) Roaming not allowed in this location area. <p>All update states of the MS are set to "Roaming not allowed" regardless whether received by individual or combined signalling. The behaviour of the MS in the roaming not allowed state is dependent on the LR reject cause as shown in table 2. Additionally:</p> <ul style="list-style-type: none"> - in automatic mode, "PLMN not allowed" and "roaming not allowed in this location area" cause the Automatic Network Selection procedure of subclause 4.4.3.1A to be started; it is also caused by "GPRS not allowed" when received by a MS capable of GPRS only; - in manual mode, "PLMN not allowed" and "roaming not allowed" cause the Manual Network Selection procedure of subclause 4.4.3.1B to be started; it is also caused by "GPRS not allowed" when received by MS capable of GPRS only.
L4	Not updated - The MS enters this state if any LR failure not specified for states L2 or L3 occurs, in which cases the MS is not certain whether or not the network has received and accepted the LR attempt. The non-GPRS update status on the SIM and/or the GPRS update status are set to "not updated" depending on the specific location registration procedure and their outcome.

4.4 PLMN selection process

4.4.1 Introduction

There are two mandatory modes for PLMN selection, automatic and manual. Optionally other modes may be supported. The mandatory modes and one optional mode are described in subclauses 4.4.3 below, Manual and Automatic mode are illustrated in figures 2a to 2b.

4.4.2 Registration on a PLMN

The MS shall perform registration on the PLMN if the MS is capable of services which require registration. In all PLMN selection modes, the concept of registration on a PLMN is used. An MS successfully registers on a PLMN if:

- a) The MS has found a suitable cell of the PLMN to camp on; and
- b) An LR request from the MS has been accepted in the registration area of the cell on which the MS is camped (see table 1).

4.4.3 PLMN selection

The registration on the selected PLMN and the location registration are only necessary if the MS is capable of services which require registration. Otherwise, the PLMN selection procedures are performed without registration.

4.4.3.1 At switch-on or recovery from lack of coverage

At switch on, the MS selects and attempts to perform a Location Registration on the registered PLMN, if it exists. On recovery from lack of coverage, the MS selects the registered PLMN (if it exists) and, if necessary (see subclause 4.5.2) attempts to perform a Location Registration.

If successful registration is achieved, the MS indicates the selected PLMN.

If there is no registered PLMN, or if registration is not possible due to the PLMN being unavailable or registration failure, the MS follows one of the following procedures depending on its operating mode.

EXCEPTION: If registration is not possible on recovery from lack of coverage due to the registered PLMN being unavailable, a MS attached to GPRS services may, optionally, continue looking for the registered PLMN for an implementation dependent time.

NOTE: A MS attached to GPRS services should use the above exception only if one or more PDP contexts are currently active.

4.4.3.1.1 Automatic Network Selection Mode Procedure

The MS selects and attempts registration on other PLMNs, if available and allowable, in all of its bands of operation in the following order:

- i) HPLMN (if not previously selected);
- ii) each PLMN in the "PLMN Selector" data field in the SIM (in priority order);
- iii) other PLMNs with received high quality signal in random order;
- iv) all other PLMNs in order of decreasing signal quality. When following the above procedure the following requirements apply:
 - a) An MS with GSM voice capability shall ignore PLMNs for which the MS has identified at least one cell that transmits CELL_BAR_QUALIFY_2.
 - b) An MS with GSM voice capability shall not search for CPBCCCH carriers.
 - c) In step i and ii, the MS should limit its search of network types to the one associated with the PLMN which it is attempting to select and register to (HPLMN or any PLMN on the PLMN selector). If a PLMN entry on the

PLMN selector specifies more than one network type, the MS may scan for network types in the order of the time it takes to identify them (with the exception of requirement b), starting with the network type that takes the shortest time to identify.

- d) In step iii and iv, the MS shall search for all network types it is capable of, with the exception of requirement b), before deciding which PLMN to select.
- e) A MS that does not have any stored network type information on the SIM shall first go through the steps by only searching for the BCCH network type. If no successful registration is achieved, then the COMPACT capable MS without GSM voice shall redo the procedure assuming that all PLMNs may be supporting all network types.

NOTE: Requirements a) and b) do not apply to MSs supporting GSM circuit-switched data without supporting GSM voice.

NOTE: High quality signal is defined in the appropriate AS specification.

If successful registration is achieved, the MS indicates the selected PLMN.

If registration cannot be achieved because no PLMNs are available and allowable, the MS indicates "no service" to the user, waits until a new PLMN is available and allowable and then repeats the procedure.

If there were one or more PLMNs which were available and allowable, but an LR failure made registration on those PLMNs unsuccessful or an entry in a forbidden LAI list prevented a registration attempt, the MS selects the first such PLMN again and enters a limited service state.

4.4.3.1.2 Manual Network Selection Mode Procedure

The MS indicates whether there are any PLMNs, in all of its bands of operation, which are available. This includes "Forbidden PLMNs". Any PLMN shall only be presented once.

If displayed, PLMNs meeting the criteria above are presented in the following order:

- i) HPLMN;
- ii) PLMNs contained in the "PLMN Selector" data field in the SIM (in priority order);
- iii) other PLMNs with received high quality signal in random order;
- iv) all other PLMNs in order of decreasing signal quality.

The user may select his desired PLMN and the MS then initiates registration on this PLMN. (This may take place at any time during the presentation of PLMNs). For such a registration, the MS shall ignore the contents of the forbidden LAI and PLMN lists.

The MS may optionally indicate which services (e.g. GPRS) are supported by the PLMNs shown in the list.

If the user does not select a PLMN, the selected PLMN shall be the one that was selected before the PLMN selection procedure started. If no such PLMN was selected or that PLMN is no longer available, then the MS shall attempt to camp on any acceptable cell and enter the limited service state.

NOTE: The scan in manual network selection mode includes PLMNs having cells with CELL_BAR_QUALIFY_2 transmitted and cells with CPBCCBs.

NOTE: High quality signal is defined in the appropriate AS specification.

4.4.3.1.3. GPRS Network Selection Mode Procedure

The MS selects and attempts registration on other PLMNs, if available and allowable, in all of its bands of operation in the following order:

- i) HPLMN
- ii) each PLMN in the "PLMN Selector" data field in the SIM which supports GPRS services (in priority order);
- iii) other PLMNs with received signal level above -85 dBm which support GPRS services in random order;

- iv) all other PLMNs which support GPRS services in order of decreasing signal strength.
- v) each PLMN in the "PLMN Selector" data field in the SIM (in priority order);
- vi) other PLMNs with received signal level above -85 dBm in random order;
- vii) all other PLMNs in order of decreasing signal strength.

NOTE: This is basically the same order as for Automatic Network Selection, except that PLMNs which support GPRS services take priority over those which do not.

The MS can determine if a PLMN supports GPRS according to the rules defined in section 4.4.3.4

If successful registration is achieved, the MS indicates the selected PLMN.

If registration cannot be achieved because no PLMNs are available and allowable, the MS indicates "no service" to the user, waits until a new PLMN is available and allowable and then repeats the procedure.

If there were one or more PLMNs which were available and allowable, but an LR failure made registration on those PLMNs unsuccessful or an entry in a forbidden LAI list prevented a registration attempt, the MS selects the first such PLMN again and enters a limited service state.

If the PLMN selected does not support GPRS services then optionally the MS may start a timer. The timer value is implementation dependent but shall not be shorter than 30 minutes. On expiry of the timer the MS scans for GPRS PLMNs. If (and only if) a PLMN which supports GPRS is available and allowable then the MS may register on this PLMN. The priority order listed above still applies.

4.4.3.2 User reselection

At any time the user may request the MS to initiate reselection and registration onto an available PLMN, according to the following procedures, dependent upon the operating mode.

4.4.3.2.1 Automatic Network Reselection Mode

This user reselection procedure can be used when the MS is in Automatic Network Selection mode.

The MS selects and attempts registration on PLMNs, if available and allowable, in all of its bands of operation in accordance with the following order:

- i) HPLMN;
- ii) PLMNs contained in the "PLMN Selector" data field in the SIM (in priority order) excluding the previously selected PLMN;
- iii) Other PLMNs with the received high quality signal in random order excluding the previously selected PLMN;
- iv) Any other PLMNs, excluding the previously selected PLMN in order of decreasing signal quality or, alternatively, the previously selected PLMN may be chosen ignoring its signal quality;
- v) The previously selected PLMN.

When following the above procedure the following requirements apply:

- a) An MS with GSM voice capability shall ignore PLMNs for which the MS has identified at least one cell that transmits CELL_BAR_QUALIFY_2.
- b) An MS with GSM voice capability shall not search for CPBCCCH carriers.
- c) In step i and ii, the MS should limit its search of network types to the one associated with the PLMN which it is attempting to select and register to (HPLMN or any PLMN on the PLMN selector). If a PLMN entry on the PLMN selector specifies more than one network type, the MS may scan for network types in the order of the time it takes to identify them (with the exception of requirement b), starting with the network type that takes the shortest time to identify.

- d) In step iii, iv, and v, the MS shall search for all network types it is capable of, with the exception of requirement b), before deciding which PLMN to select.
- e) A MS that does not have any stored network type information on the SIM shall first go through the steps by only searching for the BCCH network type. If no successful registration is achieved, then the COMPACT capable MS without GSM voice shall redo the procedure assuming that all PLMNs may be supporting all network types.

NOTE: Requirements a) and b) do not apply to MSs supporting GSM circuit-switched data without supporting GSM voice. The previously selected PLMN is the PLMN which the MS has selected prior to the start of the user reselection procedure

NOTE: High quality signal is defined in the appropriate AS specification.

4.4.3.2.2 Manual Network ReSelection

This user reselection procedure is used when the MS is in Manual Network Selection mode.

The Manual Network Selection Mode Procedure of subclause 4.4.3.2 is followed.

4.4.3.2.3 Semi Automatic Network ReSelection

This user reselection procedure is an MS option. Where implemented, it can be performed by the user in any network selection mode except for Manual Network Selection mode.

The MS indicates whether there are any PLMNs, in all of its bands of operation, which are available. This shall include any "Forbidden PLMNs". The current registered PLMN is included in the list. Any PLMN shall only be presented once.

If displayed, PLMNs meeting the criteria above are presented in the following order:

- i) HPLMN;
- ii) PLMNs contained in the "PLMN Selector" data field in the SIM (in priority order);
- iii) other PLMNs with received signal level above -85 dBm in random order;
- iv) all other PLMNs in order of decreasing signal strength.

The MS should indicate which optional services (e.g. GPRS) the displayed PLMNs support. The MS can determine if a PLMN supports GPRS according to the rules defined in section 4.4.3.4

The MS may also indicate which PLMN is the current registered PLMN, and which PLMNs are "Forbidden PLMNs".

The user may select his desired PLMN and the MS then initiates registration on this PLMN. (This may take place at any time during the presentation of PLMNs). For such a registration, the MS shall ignore the contents of the forbidden LAI and PLMN lists. If this registration fails the available PLMNs are displayed again.

If the user does not select a PLMN, or if a registration fails, the MS shall select a network according to rules defined for the currently selected Network Selection Mode (see section 4.4.3.2). However as soon as the user chooses a PLMN any existing search procedures are aborted in favour of the user's preferred choice.

4.4.3.3 In VPLMN of home country

The MS shall periodically attempt to obtain service on its HPLMN by scanning in accordance with the requirements that are applicable to step i) as defined in the Automatic Network Selection Mode. For this purpose, a value T minutes may be stored in the SIM, T is either in the range 6 minutes to 8 hours in 6 minute steps or it indicates that no periodic attempts shall be made. If no value is stored in the SIM, a default value of 30 minutes is used.

The attempts to access the HPLMN shall be as specified below:

- a) The periodic attempts shall only be performed in automatic mode when the MS is roaming in its home country;

- b) After switch on, a period of at least 2 minutes and at most T minutes shall elapse before the first attempt is made;
- c) The MS shall make an attempt if the MS is on the VPLMN at time T after the last attempt;
- d) Periodic attempts shall only be performed by the MS while in idle mode;
- e) If the HPLMN is not found, the MS shall remain on the VPLMN.

4.4.3.4. Determination of Support of GPRS Services

An MS can determine if the PLMN supports GPRS services by analysis of the broadcast system information. If the mobile can see several cells of the same PLMN but only some of them support GPRS, it is an implementation option whether the mobile considers the PLMN to support GPRS.

4.4.3.5 Investigation Scan for higher prioritized PLMN

A MS capable of both voice and packet service shall, when indicated in the SIM, investigate if there is service from a higher prioritized PLMN not offering voice service, either HPLMN or a PLMN in the "PLMN Selector" data field in the SIM. The scan shall be performed in accordance with the requirements described for automatic network selection mode in subclause 4.4.3.1 that are applicable to step i) and step ii) with the exception of requirement a) and b) in subclause 4.4.3.1. Requirement a) and b) that are specified for automatic network selection mode in subclause 4.4.3.1 shall be ignored during the investigation scan.

The investigation scan for higher prioritized PLMN shall be as specified below:

- a) The scan shall only be performed in automatic network selection mode;
- b) The scan shall only be performed by an MS that is capable of both voice and packet;
- c) The scan shall only be performed if the serving PLMN is not the highest prioritized PLMN in the current country (HPLMN in home country, otherwise according to the PLMN selector list);
- d) The scan shall be performed at least once after a successful PLMN selection is completed;
- e) The investigation scan should be performed when the MS enters idle mode;

The MS shall return to RPLMN after the investigation scan is performed.

Note: The MS remains on the RPLMN independent of the outcome of the investigation scan. The purpose of the investigation scan is to check if there is a higher prioritized PLMN, not to select it.

4.4.4 Abnormal cases

If there is no SIM in the MS, if there is an authentication failure, or if the MS receives an "IMSI unknown in HLR", "illegal ME" or "illegal MS" response to an LR request, then effectively there is no selected PLMN ("No SIM" state). In these cases, the states of the cell selection process are such that no PLMN selection information is used. No further attempts at registration on any PLMN are made until the MS is switched off and on again, or a SIM is inserted.

When in Automatic Network Selection mode (or in GPRS Network Selection Mode) the MS is in the "not updated" state with one or more suitable cells to camp on; then after the maximum allowed unsuccessful LR requests (controlled by the specific attempt counters) the MS may continue (or start if it is not running) the user reselection procedure of 4.4.3.2 1.

4.4.5 Roaming not allowed in this LA

If in either PLMN selection mode the LR response "Roaming not allowed in this LA" is received:

The PLMN Selection Procedure of subclause 4.4.3.1 are followed, depending on the PLMN selection mode.
(This requirement applies to all MSs.)

4.5 Location registration process

4.5.1 General

When the MS is switched on and capable of services requiring registration, the action taken by the location registration process is as follows:

- a) SIM present and no LR needed (because of the status of the stored registration area identity and "attach" flag):
The MS is in the update state UPDATED;
- b) SIM present and LR needed: A LR request is made;
- c) No SIM present: The MS enters the update state Idle, NO IMSI.

In case b) above, and subsequently whenever a LR request is made, the MS enters a state depending on the outcome of the LR request, as listed in subclause 4.3.2 above. In case c) the GPRS and the non-GPRS update state enters "IDLE, NO IMSI".

Whenever the MS goes to connected mode and then returns to idle mode again, the MS selects the appropriate state.

4.5.2 Initiation of Location Registration

An LR request indicating Normal Updating is made when, in idle mode,

- the MS changes cell while being in the update state NOT UPDATED; (for MS capable of GPRS and non-GPRS services when at least one of both update states is NOT UPDATED)
- the MS detects that it has entered a new registration area, i.e., when the received registration area identity differs from the one stored in the MS, and the LAI or the PLMN identity is not contained in a list of forbidden LAIs or PLMN identities respectively, while being in one of the following update states:
 - UPDATED;
 - NOT UPDATED;
 - ROAMING NOT ALLOWED.
- the Periodic Location Updating Timer expires while being in the non-GPRS update state NOT UPDATED (triggers Location Updating);
- the Periodic Routing Area Update timer expires while being in the GPRS update state NOT UPDATED (triggers Routing Area Update);
- a manual network reselection has been performed, an acceptable cell of the selected PLMN is present, and the MS is not in the UPDATED state on the selected PLMN.
- a user PLMN reselection has been performed when the PLMN selection mode is GPRS network selection mode, an acceptable cell of the selected PLMN is present, and the MS is not in the UPDATED state on the selected PLMN.

An LR request indicating Periodic Location Updating is made when, in idle mode, the Periodic Location Updating timer expires while being in the non-GPRS update state UPDATED.

An LR request indicating Periodic Routing Area Update is made when the Periodic Routing Area Update timer expires while being in the GPRS update state UPDATED.

An LR request indicating IMSI attach is made when the MS is activated in the same location area in which it was deactivated while being in the non-GPRS update state UPDATED, and the system information indicates that IMSI attach/detach shall be used.

A GPRS attach is made by a GPRS MS when activated and capable of services which require registration. Depending on system information about GPRS network operation mode MSs capable of GPRS and non-GPRS services perform combined or non-combined location registration procedures. When the combined routing area update or GPRS attach is accepted with indication "MSC not reachable" or is not answered the MS performs also the corresponding location

updating procedure or falls back to a GPRS only MS. When the combined routing area update or GPRS attach is rejected with cause "GPRS not allowed" the GPRS update state is "IDLE, NO IMSI" and the MS performs the corresponding location updating procedure or falls back to a GPRS only MS.

Furthermore, an LR request indicating Normal Location Updating is also made when the response to an outgoing request shows that the MS is unknown in the VLR or SGSN, respectively.

Table 2 summarizes the events in each state that trigger a new LR request. The actions that may be taken while being in the various states are also outlined in table 2.

A GPRS MS which is both IMSI attached for GPRS and non-GPRS services and which is capable of simultaneous operation of GPRS and non-GPRS services shall perform Routing Area Update in connected mode when it has entered a new routing area which is not part of a LA contained in the list of forbidden LAIs.

4.5.3 Periodic Location Registration

A Periodic Location Updating timer (for non-GPRS operation) and a Periodic Routing Area Update timer (for GPRS operation) with the following characteristics shall be implemented in the MS (MS capable of GPRS and non-GPRS operation shall implement both timers):

- i) Upon switch on of the MS or when the system information indicates that periodic location registration shall be applied, and the timer is not running, the timer shall be loaded with a random value between 0 and the broadcast or signalled time-out value and started.
- ii) The time-out value for the Periodic Location Updating timer shall be within the range of 1 deci-hour to 255 deci-hours with a granularity of 1 deci-hour.
- iii) When the timer reaches its expiry value, it shall be initiated with respect to the relevant time-out value, and the MS shall initiate the Periodic Location Registration corresponding to the expired timer.
- iv) The Periodic Location Updating timer shall be prevented from triggering Periodic Location Updating during connected mode. When the MS returns to idle mode, the Periodic Location Updating timer shall be initiated with respect to the broadcast time-out value, then started. Thereafter, the procedure in iii) shall be followed.
- v) The Periodic Routing Area Update timer shall be prevented from triggering the Periodic Routing Area Update during Ready state. At transition from Ready to Standby state the Periodic Routing Area Update timer shall be initiated with respect to its time-out value, then started. Thereafter, the procedure in iii) shall be followed.
- vi) If the MS performs a successful combined Routing Area Update the Periodic Location Updating timer shall be prevented from triggering the Periodic Location Updating until the MS starts using Location Updating procedure, for example because of a changed network operation mode or the MS uses non-GPRS services only.
- vii) When a change in the time-out value occurs (at a change of serving cell or a change in the broadcast time-out value or a change in the signalled time-out value), the related timer shall be reloaded so that the new time to expiry will be: "old time to expiry" modulo "new time-out value".

4.5.4 IMSI attach/detach operation

The system information will contain an indicator indicating whether or not IMSI attach/detach operation is mandatory to use in the cell. The MS shall operate in accordance with the received value of the indicator.

A GPRS MS shall perform GPRS attach/detach procedures independent of the value of the IMSI attach/detach indicator. When a GPRS MS has to perform IMSI attach/detach independent of GPRS procedures (for example GPRS network operation mode 2) the handling described in the paragraph above applies.

When IMSI attach/detach operation applies, a MS shall send the IMSI detach message to the network when the MS is powered down or the SIM is removed while being in the update state UPDATED. The IMSI detach message will not be acknowledged by the network.

When the MS returns to the active state, the MS shall perform an LR request indicating IMSI attach, provided that the MS still is in the same registration area. If the registration area has changed, an LR request indicating Normal Location Updating according to subclause 4.5.2 shall be performed.

4.6 Service indication

This is an indication to the user that service or CTS service is available.

The service indication should be set if the following conditions are all satisfied:

- a) Cell Selection: Camped on a suitable cell and in updated state, or in connected mode having been camped on a suitable cell.
- b) Location registration: In updated state, for MSs capable of services requiring registration.

A specific CTS service indication should be set when the CTS MS is attached to a CTS FP.

However due to the fact that there may be some transitory changes of state, the service indication is permitted to continue to be set for up to 10 seconds after the above conditions cease to be met. Also the service indication is permitted to take up to 1 second to be set after the above conditions are met.

4.7 Pageability of the mobile subscriber

An MS is required to listen to all paging messages that could address it (see GSM 05.02), when the following conditions are all satisfied:

- A SIM is inserted.
- The MS is camped on a cell.
- The MS is not in state "Idle, No IMSI".
- The MS is not performing the task to search for available PLMNs. (Whenever possible during this task, the MS should listen for paging.) However, when the MS is camped on a cell, is registered in a PLMN and is performing its regular search for the HPLMN, as specified in GSM 02.11, then it shall listen to all paging messages that could address it.

NOTE 1: In GSM, during cell reselection there is a certain period when the MS is no longer camped on the old cell but must decode the full BCCH or CPBCCH before camping on the new cell. This leads to a period of slightly more than 8 51 frame multiframes when the MS will not necessarily be pageable.

4.8 MM Restart Procedure

In some cases, e.g. on change of SIM data, there is a need for the MM to be restarted without the need for user intervention.

To perform the procedure the MS shall behave as if the SIM is removed and afterwards a new SIM is inserted.

5 Tables and Figures

Table 1: Effect of LR Outcomes on PLMN Registration

Location Registration Task State	Registration Status	Registered PLMN is
Updated	Successful	Indicated in the stored registration area identity
Idle, No IMSI	Unsuccessful	No registered PLMN (3)
Roaming not allowed:		
a) PLMN not allowed	Unsuccessful	No registered PLMN
b) LA not allowed	Indeterminate(1)	No registered PLMN
c) Roaming not allowed in this LA	Indeterminate (2)	No registered PLMN
Not updated	Unsuccessful	No registered PLMN

1) The MS will eventually either enter a different state when the registration status will be determined, or fail to be able to camp on a cell, when registration will be unsuccessful.

2) The MS will select the HPLMN if in automatic mode and will enter Automatic Network Selection Mode Procedure of subclause 4.4.3.1.1. If in manual mode, the MS will display the list of available PLMNs and follow the Manual Network Selection Mode Procedure of subclause 4.4.3.1.2. Other PLMN selection modes will behave in a similar manner. If the appropriate process does not result in registration, the MS will eventually enter the limited service state.

3) A MS may have different update states for GPRS and non-GPRS. A PLMN is registered when at least one of both update states is updated.

NOTE 1: MSs capable of GPRS and non-GPRS services may have different registration status for GPRS and for non-GPRS.

NOTE 2: The registered PLMN is determined by looking at the stored registration area identity and stored location registration status.

Table 2: LR Process States and Allowed Actions

Location registration task state	New LR request when				Normal Calls Supported (1)	Paging responded to
	Changing Cell	Changing registration area	Changing PLMN	Other		
Null (4)	No	Yes	Yes	No	No	No
Updated, (5)	No	Yes	Yes	(2)	Yes	Yes
Idle, No IMSI (7)	No	No	No	No	No	No
Roaming not allowed:						
a) Idle, PLMN not allowed	No	No	Yes	No	No	Optional if with IMSI
b) Idle, LA not allowed	No	Yes(6)	Yes	No	No	Optional if with IMSI
c) Idle, Roaming not allowed in this LA	No	Yes(6)	Yes	No	No	Optional if with IMSI
Not updated	Yes	Yes	Yes	(2)&(3)	(3)	Yes if with IMSI

- 1): Emergency calls may always be made, subject to access control permitting it.
- 2): A new LR is made when the periodic registration timer expires.
- 3): If a normal call request is made, an LR request is made. If successful the updated state is entered and the call may be made.
- 4): The MS is in the null state from switch on until it has camped on a cell and either made an LR attempt or decided that no LR attempt is needed.
- 5): In this state, IMSI detach is performed if the MS is deactivated and the BCCH indicates that IMSI attach/detach shall be used. An LR request indicating IMSI attach is performed if the MS is activated in the same registration area in which it was deactivated while being in this state.
- 6): A GPRS MS shall not perform a new LR when the new routing area is part of a LA contained in a list of forbidden LA.
- 7): The GPRS registration status "Idle, no IMSI" is entered when LR is rejected with cause "GPRS not allowed". The non-GPRS registration status „Idle, no IMSI“ is entered when the cause "IMSI unknown in HLR" is received.

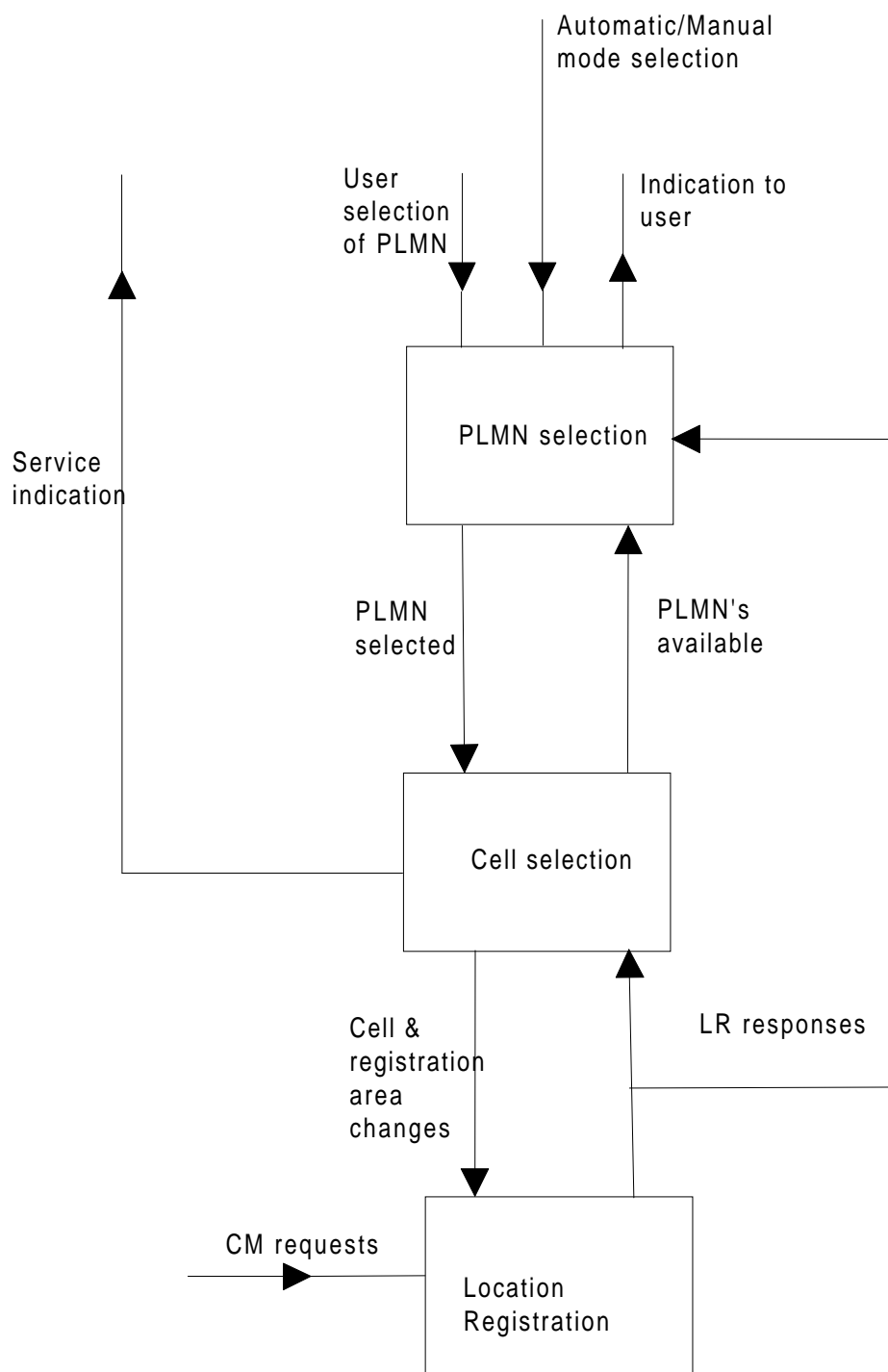
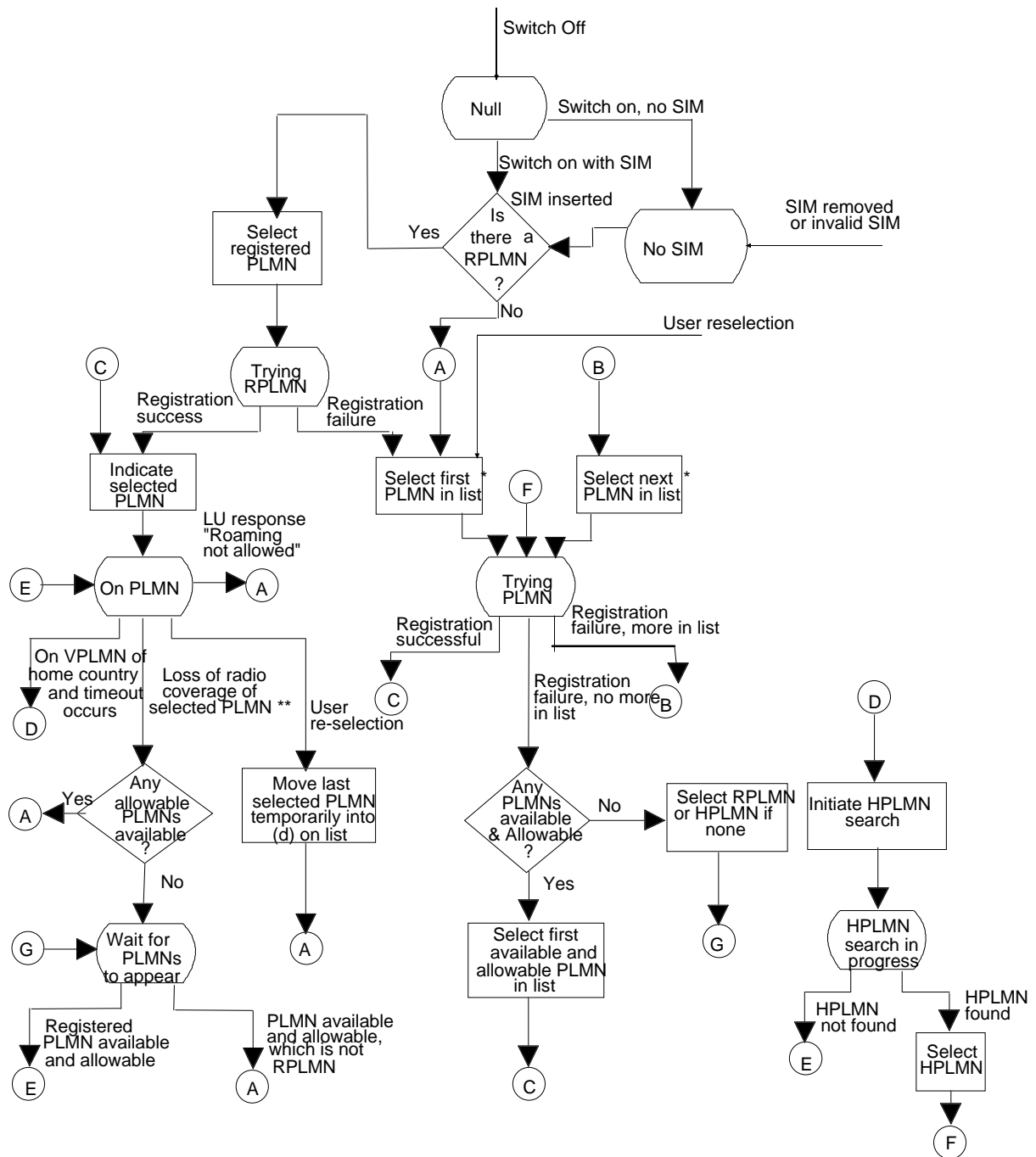

Figure 1: Overall Idle Mode process



* "List" consists of (in order)

- a) HPLMN
 - b) Each PLMN in SIM list in priority order
 - c) All other PLMNs above -85 dBm in random order
 - d) Other PLMNs in decreasing order of signal strength
-) Provided they are "available" and "allowable"

** Includes effective loss of coverage due to LAs being forbidden in all potentially suitable cells

Figure 2a: PLMN Selection State diagram (automatic mode)

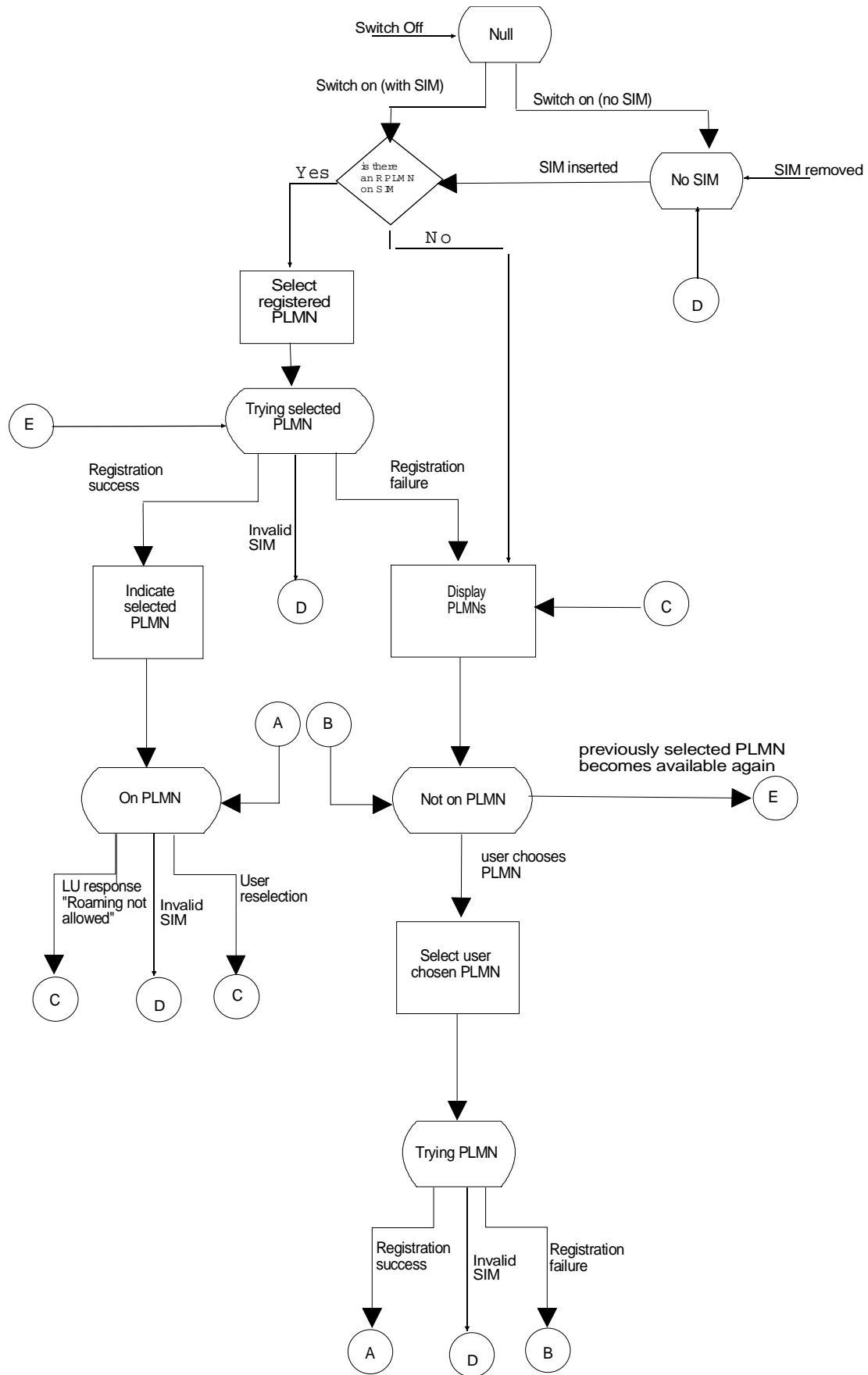

Figure 2b: PLMN Selection State diagram (manual mode)

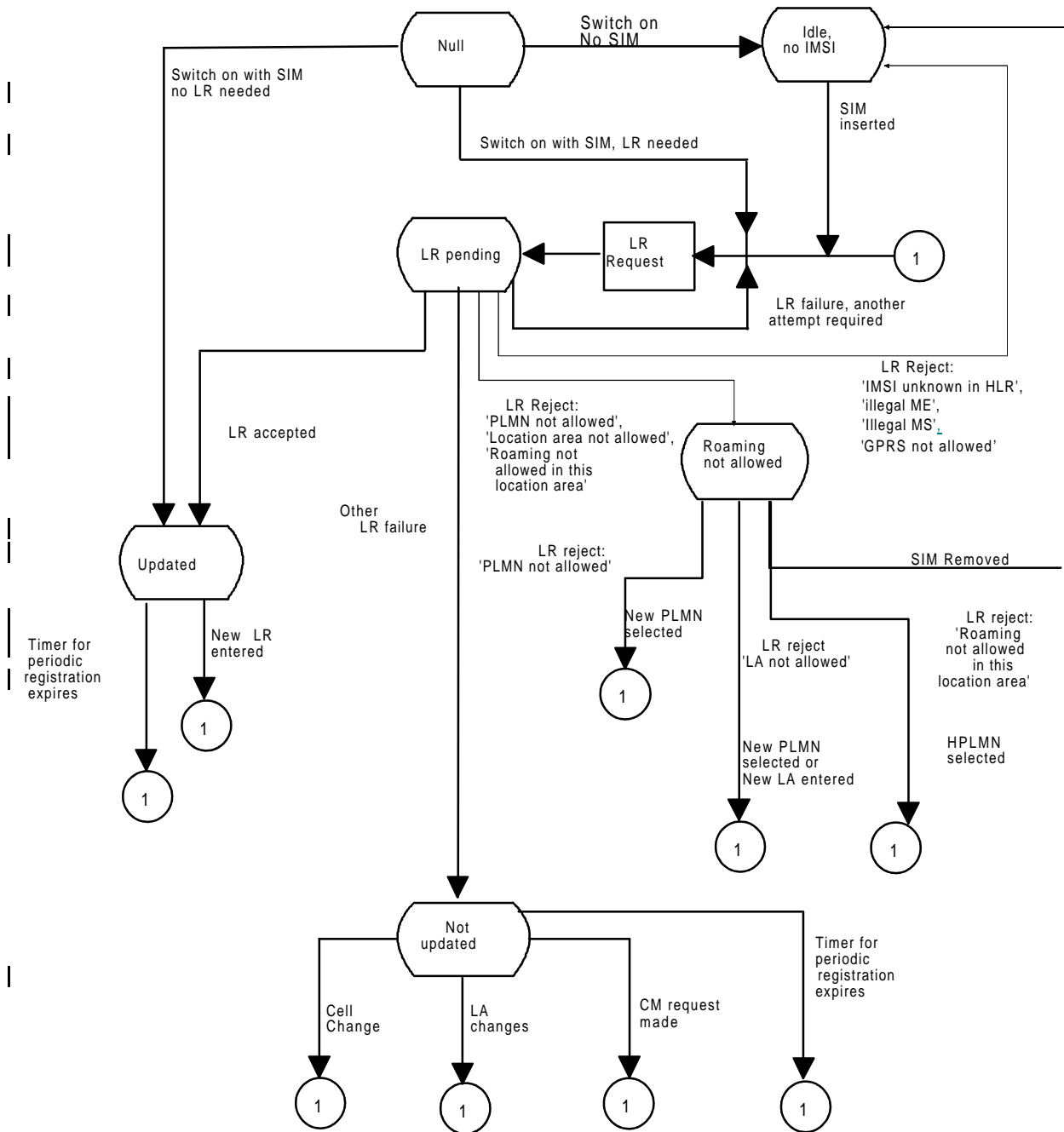

Figure 3: Location Registration Task State diagram

NOTE: Whenever the MS goes to connected mode and then returns to idle mode again the MS selects appropriate state.

NOTE: A MS capable of GPRS and non-GPRS services has two Task State machines one for GPRS and one for non-GPRS operation.

Annex A (normative): HPLMN Matching Criteria

With the introduction of PCS1900 with the regulatory mandate to allocate 3-digit MNC codes, additional functionality is required to identify the HPLMN.

Assumptions

An MNC code shall consist of 2 or 3 decimal digits. In NA PCS1900, all SIMs shall store 3 digit MNCs.

Any network using a 2 digit MNC code shall broadcast the hexadecimal code "F" in place of the 3rd digit.

For PCS1900 for North America, regulations mandate that a 3-digit MNC shall be used; however during a transition period, a 2 digit MNC may be broadcast by the Network and, in this case, the 3rd digit of the SIM is stored as 0 (this is the 0 suffix rule).

With the exception of North America during the transition period:

- a) Within a single country (or area identified by a MCC) all networks shall broadcast a 2 digit MNC code, or all networks shall broadcast a 3 digit MNC code. A mixture of broadcast 2 and 3 digit MNC codes is not permitted within a single country (or area identified by a MCC).
- b) A network which broadcasts a 2 digit MNC code, will issue SIMs with a 2 digit MNC code in the IMSI on the SIM. A network which broadcasts a 3 digit MNC code, will issue SIMs with a 3 digit MNC code in the IMSI on the SIM.

Definitions and abbreviations

BCCH-MCC	The MCC part of the LAI read from System Information type 3 messages broadcast on the BCCH by the network.
BCCH-MNC	The MNC part of the LAI read from System Information type 3 messages broadcast on the BCCH by the network.
SIM-MCC	The MCC part of the IMSI read from the SIM.
SIM-MNC	The MNC part of the IMSI read from the SIM.

HPLMN Matching Criteria in mobiles which don't support PCS1900 for NA:

Figure A.1 illustrates the logic flow described below. The text below is normative. The Figure A.1 is informative.

- (1) The MS shall compare using all 3 digits of the SIM-MCC with the BCCH-MCC. If the values do not match, then the HPLMN match fails.

NOTE: If the MCC codes match, then the number of digits used for the SIM-MNC must be the same as the number of digits used for the BCCH-MNC.

- (2) The MS shall read the 3rd digit of the BCCH-MNC. If the 3rd digit is Hex F, then proceed to step (4).
- (3) The MS shall compare using all 3 digits of the SIM-MNC with the BCCH-MNC. If the values match, then the HPLMN match succeeds, otherwise the HPLMN match fails.
- (4) The MS shall compare using just the 1st 2 digits the SIM-MNC with the BCCH-MNC. If the values match, then the HPLMN match succeeds, otherwise the HPLMN match fails.

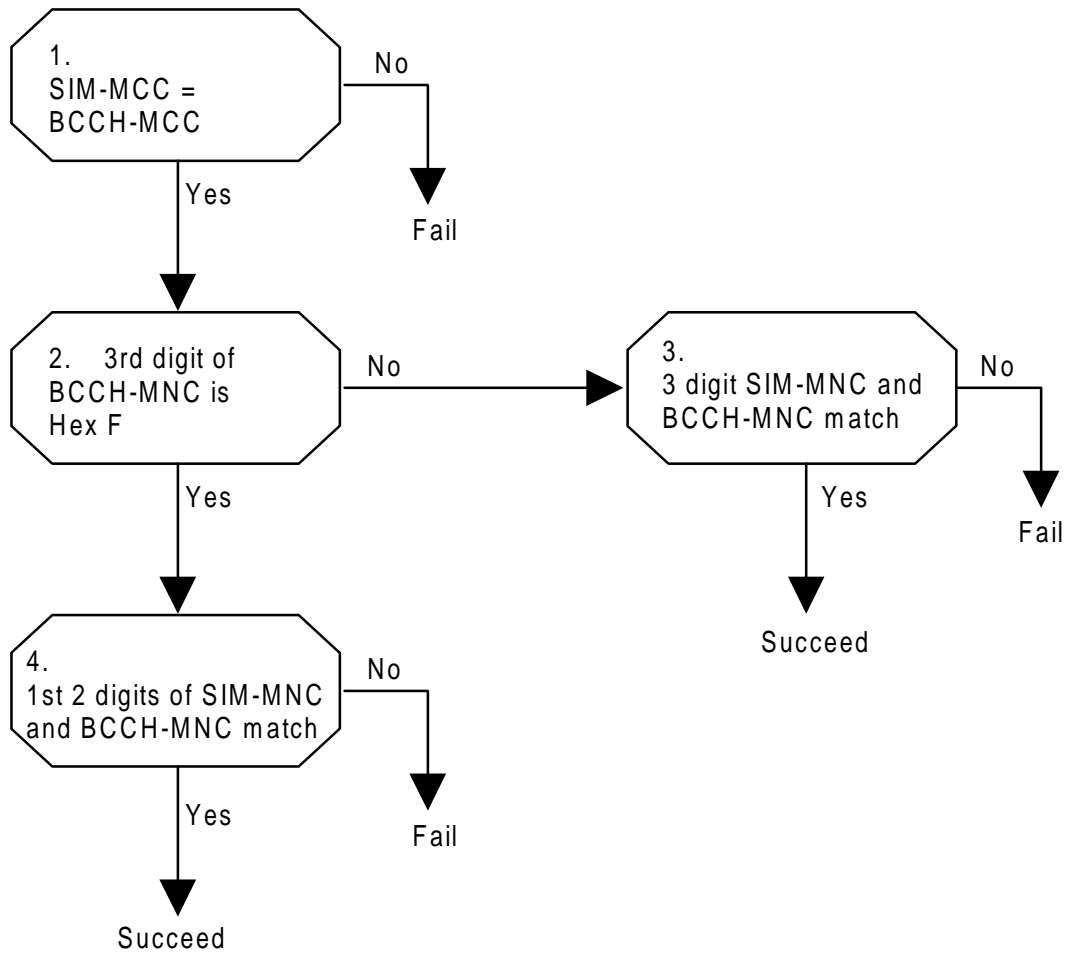

Figure A.1: HPLMN Matching Criteria Logic Flow for mobiles which support GSM and DCS1800 (informative)

HPLMN Matching Criteria for mobiles which support PCS1900 for NA:

Figure A.2 illustrates the logic flow described below. The text below is normative. The Figure A.2 is informative

- (1) The MS shall compare using all 3 digits the SIM-MCC with the BCCH-MCC. If the values do not match, then the HPLMN match fails.
- (2) The MS shall read the 3rd digit of the BCCH-MNC. If the 3rd digit is Hex F, then proceed to step (4).
- (3) The MS shall compare using all 3 digits the SIM-MNC with the BCCH-MNC. If the values match, then the HPLMN match succeeds, otherwise the HPLMN match fails.

NOTE: These rules (1) – (3) are the same as for mobiles which don't support PCS1900 for NA, except step (4) is different.

- (4) The MS shall determine if the BCCH-MCC lies in the range 310-316 (i.e., whether this network is a PCS1900 for NA network). If the BCCH-MCC lies outside the range 310-316, then proceed to step (6).
- (5) The MS shall compare the 3rd digit of the SIM-MNC with '0'. If the 3rd digit is not '0' then the HPLMN match fails.

NOTE: This is the '0' suffix rule.

- (6) The MS shall compare using just the 1st 2 digits of the SIM-MNC with the BCCH-MNC. If the values match, then the HPLMN match succeeds, otherwise the HPLMN match fails.

NOTE: When PCS1900 for NA switches over to broadcasting 3 digit MNCs in **all** networks, then the additional requirements for PCS1900 for NA can be deleted.

Guidance for Networks in PCS1900 for NA

There may be some problems in the transition period from broadcasting 2 MNC digits to broadcasting 3 MNC digits. Here are some guidelines to avoid these problems.

- (1) Existing network codes. Operators who currently use a 2 digit BCCH-MNC **xy** should use the new code **xy0**.
- (2) New operators allocated 3 digit MNC codes with the same 1st 2 digits as an existing operator shall not use a 3rd digit of 0.

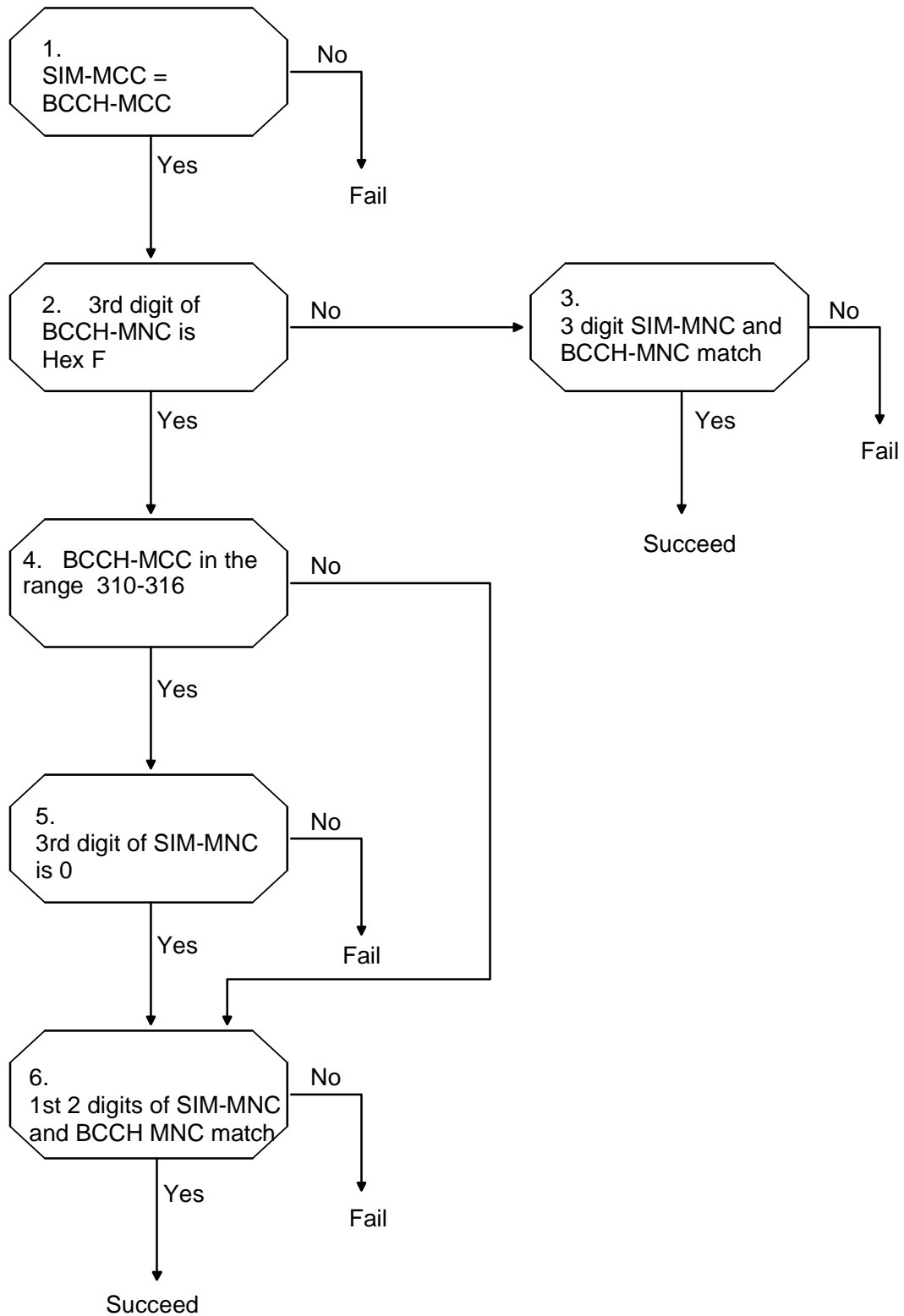

Figure A.2: HPLMN Matching Criteria Logic Flow for mobiles which support PCS1900 for NA (informative)

Annex B (informative): Change history

TSG#	Tdoc	SPEC	VER	CR	R	PHA	CA	NEW_	SUBJECT	comment
		03.22	8.2.0			R99			Split of 03.22/R99 to 03.22 and 23.122	
CN#6		23.122	0.0.0			R99		3.0.0		Was approved in the TSGN#6 plenary
CN#4	N1-99573	23.102	3.0.0	001		R99	F	3.1.0	PLMN selection for GPRS mobiles	Mirrored from CRA032r2
CN#6	N1-99D13	23.122	3.0.0	002		R99	A	3.1.0	Correction of Figure A.2 in Annex A	Mirrored from CR006r1for 23.022

History

Document history		
V3.1.0	January 2000	Publication