

# ETSI TS 122 002 V4.1.0 (2001-03)

---

*Technical Specification*

**Digital cellular telecommunications system (Phase 2+) (GSM);  
Universal Mobile Telecommunications System (UMTS);  
Circuit Bearer Services (CS) supported by  
a Public Land Mobile Network (PLMN)  
(3GPP TS 22.002 version 4.1.0 Release 4)**

---



---

**Reference**

RTS/TSGS-0122002Uv4

---

**Keywords**

GSM, UMTS

**ETSI**

650 Route des Lucioles  
F-06921 Sophia Antipolis Cedex - FRANCE

---

Tel.: +33 4 92 94 42 00 Fax: +33 4 93 65 47 16

Siret N° 348 623 562 00017 - NAF 742 C  
Association à but non lucratif enregistrée à la  
Sous-Préfecture de Grasse (06) N° 7803/88

---

**Important notice**

---

Individual copies of the present document can be downloaded from:

<http://www.etsi.org>

The present document may be made available in more than one electronic version or in print. In any case of existing or perceived difference in contents between such versions, the reference version is the Portable Document Format (PDF). In case of dispute, the reference shall be the printing on ETSI printers of the PDF version kept on a specific network drive within ETSI Secretariat.

Users of the present document should be aware that the document may be subject to revision or change of status. Information on the current status of this and other ETSI documents is available at <http://www.etsi.org/tb/status/>

If you find errors in the present document, send your comment to:  
editor@etsi.fr

---

**Copyright Notification**

---

No part may be reproduced except as authorized by written permission.  
The copyright and the foregoing restriction extend to reproduction in all media.

© European Telecommunications Standards Institute 2001.

All rights reserved.

---

## Intellectual Property Rights

IPRs essential or potentially essential to the present document may have been declared to ETSI. The information pertaining to these essential IPRs, if any, is publicly available for **ETSI members and non-members**, and can be found in ETSI SR 000 314: "*Intellectual Property Rights (IPRs); Essential, or potentially Essential, IPRs notified to ETSI in respect of ETSI standards*", which is available from the ETSI Secretariat. Latest updates are available on the ETSI Web server (<http://www.etsi.org/ipr>).

Pursuant to the ETSI IPR Policy, no investigation, including IPR searches, has been carried out by ETSI. No guarantee can be given as to the existence of other IPRs not referenced in ETSI SR 000 314 (or the updates on the ETSI Web server) which are, or may be, or may become, essential to the present document.

---

## Foreword

This Technical Specification (TS) has been produced by the ETSI 3<sup>rd</sup> Generation Partnership Project (3GPP).

The present document may refer to technical specifications or reports using their 3GPP identities, UMTS identities or GSM identities. These should be interpreted as being references to the corresponding ETSI deliverables.

The cross reference between GSM, UMTS, 3GPP and ETSI identities can be found under [www.etsi.org/key](http://www.etsi.org/key).

---

# Contents

Foreword.....	4
0 Scope .....	5
0.1 References .....	5
0.2 Abbreviations .....	5
1 Framework for defining Circuit Bearer Services .....	6
2 Bearer Service categories .....	7
3 Bearer Services .....	7
3.1 General bearer service user data characteristics .....	8
3.1.1 BS 20 (asynchronous services).....	8
3.1.1.1 BS 20 T (transparent asynchronous services).....	8
3.1.1.1.1 BS 20 transparent in regular mode for analogue interworking .....	8
3.1.1.1.2 BS 20 transparent in regular mode for digital interworking .....	9
3.1.1.2 BS 20 NT (non-transparent asynchronous services).....	9
3.1.1.2.1 BS 20 non-transparent in regular mode for analogue interworking .....	9
3.1.1.2.2 BS 20 non-transparent in regular mode for digital interworking .....	10
3.1.1.2.3 BS 20 non-transparent for PIAFS .....	10
3.1.1.2.4 BS 20 non-transparent for Frame Tunnelling Mode .....	10
3.1.1 BS 30 (synchronous services).....	11
3.1.2.1 BS 30 T (transparent synchronous services) .....	11
3.1.2.1.1 BS 30 transparent in regular mode for analogue interworking .....	11
3.1.2.1.2 BS 30 transparent in regular mode for digital interworking .....	11
3.1.2.1.3 BS 30 transparent for Multimedia.....	12
<b>Annex A (informative): Change history .....</b>	<b>13</b>

---

# Foreword

This Technical Specification has been produced by the 3GPP.

The contents of the present document are subject to continuing work within the TSG and may change following formal TSG approval. Should the TSG modify the contents of the present document, it will be re-released by the TSG with an identifying change of release date and an increase in version number as follows:

Version x.y.z

where:

- x the first digit:
  - 1 presented to TSG for information;
  - 2 presented to TSG for approval;
  - 3 or greater indicates TSG approved document under change control.
- y the second digit is incremented for all changes of substance, i.e. technical enhancements, corrections, updates, etc.
- z the third digit is incremented when editorial only changes have been incorporated in the document.

---

## 0 Scope

The present document defines a set of Circuit Bearer Services to be provided to PLMN subscribers by a PLMN itself and in connection with other networks. This TS should also be used as a reference for defining the corresponding required mobile network capabilities.

### 0.1 References

The following documents contain provisions which, through reference in this text, constitute provisions of the present document.

- References are either specific (identified by date of publication, edition number, version number, etc.) or non-specific.
- For a specific reference, subsequent revisions do not apply.
- For a non-specific reference, the latest version applies. In the case of a reference to a 3GPP document (including a GSM document), a non-specific reference implicitly refers to the latest version of that document *in the same Release as the present document*.

- [1] TS 41.004: "Digital cellular telecommunications system (Phase 2+); Abbreviations and acronyms".
- [2] TS 22.001: " Principles of circuit telecommunication services supported by a GSM Public Land Mobile Network (PLMN)".
- [3] TS 22.004: " General on supplementary services".
- [4] TS 27.001: " General on Terminal Adaptation Functions (TAF) for Mobile Stations (MS)".
- [5] TS 27.002: " Terminal Adaptation Functions (TAF) for services using asynchronous bearer capabilities".
- [6] TS 27.003: " Terminal Adaptation Functions (TAF) for services using synchronous bearer capabilities".
- [7] TS 27.005: "Use of Data Terminal Equipment - Data Circuit terminating Equipment (DTE - DCE) interface for Short Message Service (SMS) and Cell Broadcast Service (CBS)".
- [8] TS 29.002: " Mobile Application Part (MAP) specification".
- [9] TS 29.007: "General requirements on interworking between the Public Land Mobile Network (PLMN) and the Integrated Services Digital Network (ISDN) or Public Switched Telephone Network (PSTN)".
- [10] TS 29.010: " Information element mapping between Mobile Station - Base Station System and BSS - Mobile-services Switching Centre (MS - BSS - MSC) Signalling procedures and the Mobile Application Part (MAP)".
- [11] TS 29.011: " Signalling interworking for supplementary services".
- [12] ITU-T Recommendation V.120: "Support by an ISDN of data terminal equipments with V-series type interface with provision for statistical multiplexing".
- [13] TR 21.905: "Vocabulary for 3GPP Specifications"

### 0.2 Abbreviations

Abbreviations used in this TS are listed in TS 41.004 [1] and TR 21.905 [13].

# 1 Framework for defining Circuit Bearer Services

Bearer Services are described by attributes, which are intended to be independent. These attributes are described and defined in TS 22.001 [2]. They are grouped into four categories:

- i) Information transfer attributes, which characterize the network capabilities for transferring information from a user access point in a PLMN to a user access point in another network. (Refer to TS 22.001 [2]).
- ii) Access attributes, which describe the means for accessing network functions or facilities as seen at the access point in the PLMN (see TS 22.001 [2]).
- iii) Interworking attributes, which describe properties of the terminating network and its access point. The terminating network may include another PLMN or the originating PLMN.
- iv) General attributes, which deal with the service in general.

Figure 1 shows the relation between the groups of attributes and their fields of applicability.

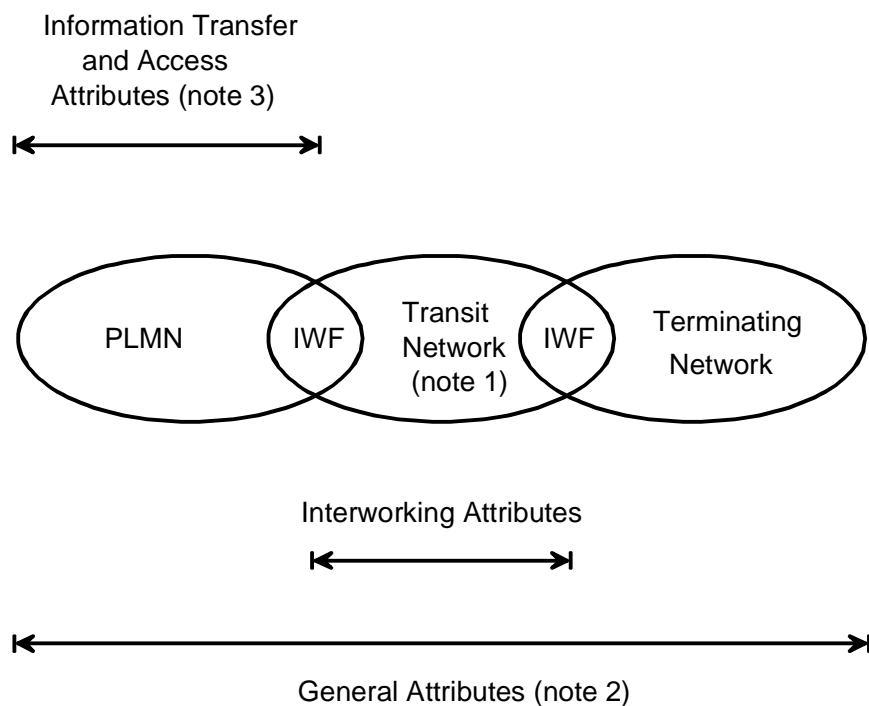

NOTE 1: A transit network may not exist for a Bearer Service.

NOTE 2: Communication may be established from either end.

NOTE 3: The information transfer and access attributes of a Bearer Service relate to a direct peer-to-peer communication of:

- TE to TE;
- TE to a network gateway (supporting, for example, PSTN interworking); or
- network gateway to a TE.

**Figure 1: Relation between the groups of attributes and fields of applicability**

The following table lists the individual attributes in each of the four groups. The Bearer Service definitions in this specification are based on the "Minimal Set" of attributes.

**Table 1: List of Bearer Service attributes**

	<b>Minimal Set</b>
<b>Information Transfer Attributes</b>	
Information Transfer Mode	X
Information Transfer Rate	X
Information Transfer Capability	X
Establishment of Communication	X
Symmetry	X
Communication Configuration	X
Data Compression	
<b>Access Attributes</b>	
Access Channel and Rate	
Signalling Access Protocols	
Information Access Protocols	
Information Access Structure	X
Information Access Rate	X
<b>Interworking Attributes</b>	
<b>General Attributes</b>	
Supplementary Services Provided	
Quality of Service	X
Operational and Commercial	

Attributes that are not part of the minimal set provide further technical detail and are required to fully define the use of each Bearer Service.

See specifications [4], [5], [6], [7] for information about the Signalling Access Protocols, Information Access Protocols and related access attributes.

Supplementary services are defined in TS 22.004 [3].

Intercommunication is required with services in the PSTN, ISDN and other PLMNs. The capabilities that describe the Interworking Attributes are described in specifications [8] to [9] and [15].

## 2 Bearer Service categories

All Bearer Service categories provide information transfer between the reference points and allow the use of sub-rate information streams which are rate-adapted.

The Bearer Services can be grouped into the following categories:

- Unrestricted Digital Information (UDI);

Provides the transfer of unrestricted digital information.

- 3,1 kHz (External to the PLMN);

Used to select a "3,1 kHz audio" interworking function at the MSC. This service category is used when interworking with the ISDN or PSTN "3,1 kHz audio" service and includes the capability to select a modem at the interworking function. "External to the PLMN" indicates that the "3,1 kHz audio" service is only used outside of the PLMN, in the ISDN/PSTN. The connection within the PLMN, user access point to the interworking function, is an unrestricted digital connection.

## 3 Bearer Services

This clause provides a list of the existing Bearer Services and indicates the values for each attribute in the minimal set.

The following attributes have the same value for all Bearer Services. Their values are as follows:

Information Transfer Mode: "Circuit";



Information Transfer Rate: Not applicable (note 1);  
 Establishment of Communication: "Demand";  
 Symmetry: "Bi-directional Symmetric";  
 Communication Configuration: "Point to point".

NOTE 1: The Information Transfer Rate attribute is not applicable because it depends on the reference point assumed in the PLMN, transit or terminating network.

All asynchronous NT Bearer Services may support data compression to enhance user data throughput.

NT Bearer Services 20 may support V.120 interworking, enabling data terminals connected to an UE to interwork with V.120 [12] terminal adapters on the ISDN as shown in the figure 2 below.

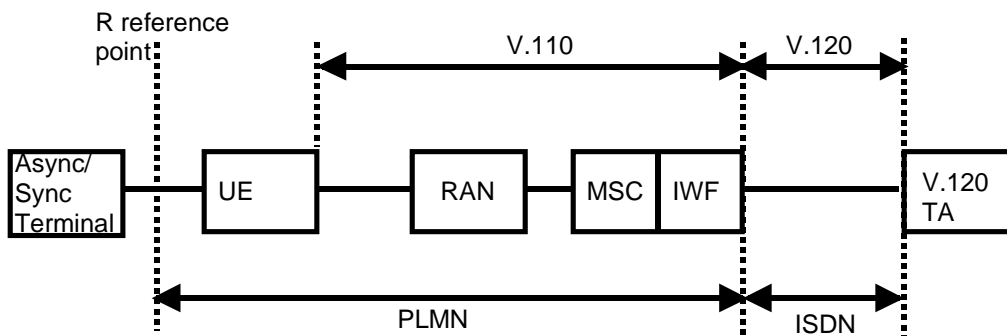

Figure 2: Model of V.120 Interworking

Table 2 contains the list of the Bearer Services and the values for the remaining attributes in the minimal set.

Table 2

Bearer Service Number	Bearer Service Name	Access Structure	Access Rate	Information Transfer Capability	QOS Attribute	Notes
20	Asynchronous General Bearer Service	Asynch	note 1	3.1 kHz , UDI, RDI	NT / T	
30	Synchronous General Bearer Service	Synch	note 1	3.1 kHz , UDI, RDI	T	

Note 1: This General Bearer is independent of any nominal rate. It is elaborated in more detail in subclause 3.1

### 3.1 General bearer service user data characteristics

The tables below describe the characteristics of the General Bearer Services. The indicated fixed network user rates are possible, but support of General Bearer Service does not imply support of all rates.

#### 3.1.1 BS 20 (asynchronous services)

##### 3.1.1.1 BS 20 T (transparent asynchronous services)

###### 3.1.1.1.1 BS 20 transparent in regular mode for analogue interworking

Fixed Network User Rate	Access Structure	Information Transfer Capability	Rate Adaptation	QoS attributes	Note
0.3 kbit/s	Asynch	3,1 kHz	-	T	Note 1
1.2 kbit/s	Asynch	3,1 kHz	-	T	Note 1
2.4 kbit/s	Asynch	3,1 kHz	-	T	Note 1
4.8 kbit/s	Asynch	3,1 kHz	-	T	Note 1
9.6 kbit/s	Asynch	3,1 kHz	-	T	Note 1
14.4 kbit/s	Asynch	3,1 kHz	-	T	Note 1
19.2 kbit/s	Asynch	3,1 kHz	-	T	Note 1
28.8 kbit/s	Asynch	3,1 kHz	-	T	
			-		

NOTE 1: Only applicable in GSM

### 3.1.1.1.2 BS 20 transparent in regular mode for digital interworking

Fixed Network User Rate	Access Structure	Information Transfer Capability	Rate Adaptation	QoS Attribute	Notes
0.3 kbit/s	Asynch	UDI	V.110	T	Note 1
1.2 kbit/s	Asynch	UDI	V.110	T	Note 1
2.4 kbit/s	Asynch	UDI	V.110	T	Note 1
4.8 kbit/s	Asynch	UDI	V.110	T	Note 1
9.6 kbit/s	Asynch	UDI	V.110	T	Note 1
14.4 kbit/s	Asynch	UDI	V.110	T	Note 1
19.2 kbit/s	Asynch	UDI	V.110	T	Note 1
28.8 kbit/s	Asynch	UDI	V.110	T	
38.4 kbit/s	Asynch	UDI	V.110	T	Note 1
		UDI			
		UDI			
56 kbit/s	Synch	RDI	-	T	
64 kbit/s	Synch	UDI	-	T	

NOTE 1: Only applicable in GSM

### 3.1.1.2 BS 20 NT (non-transparent asynchronous services)

#### 3.1.1.2.1 BS 20 non-transparent in regular mode for analogue interworking

Fixed Network User Rate	Access Structure	Information Transfer Capability	QoS attributes	Note
0.3 kbit/s	Asynch	3,1 kHz	NT	Note 1 and 3
1.2 kbit/s	Asynch	3,1 kHz	NT	Note 1 and 3
2.4 kbit/s	Asynch	3,1 kHz	NT	Note 1 and 3
4.8 kbit/s	Asynch	3,1 kHz	NT	Note 1 and 3
9.6 kbit/s	Asynch	3,1 kHz	NT	
14.4 kbit/s	Asynch	3,1 kHz	NT	
19.2 kbit/s	Asynch	3,1 kHz	NT	
28.8 kbit/s	Asynch	3,1 kHz	NT	
	Asynch	3,1 kHz	NT	Note 2

NOTE 1: These services are also supported by the GSM Phase 2 Specifications.

NOTE 2: This is used with high speed modems such as V.90 (56kbit/s). Modem type = 'Autobauding Type 1' is selected. FNUR has no meaning in this case.

NOTE 3: In case of UTRAN the FNURs 300, 1200, 2400 and 4800 bit/s towards the fixed network can be provided only with modem type = 'Autobauding Type 1' is selected.

### 3.1.1.2.2 BS 20 non-transparent in regular mode for digital interworking

Fixed Network User Rate	Access Structure	User Information Layer 1 protocol	QoS Attribute	Notes
0.3 kbit/s	Asynch	V.110	NT	Note 1 and 2
1.2 kbit/s	Asynch	V.110	NT	Note 1 and 2
2.4 kbit/s	Asynch	V.110	NT	Note 1 and 2
4.8 kbit/s	Asynch	V.110	NT	Note 1 and 2
9.6 kbit/s	Asynch	V.110	NT	Note 1
14.4 kbit/s	Asynch,	V.110	NT	
19.2 kbit/s	Asynch	V.110	NT	
28.8 kbit/s	Asynch	V.110	NT	
38.4 kbit/s	Asynch	V.110	NT	

NOTE 1: These services are also supported by the GSM Phase 2 Specifications.

NOTE 2: In case of UTRAN the user rates 300, 1200, 2400 and 4800 bit/s towards the fixed network can be provided only for mobile terminated calls.

Fixed Network User Rate	Access Structure	Information Transfer Capability	Rate Adaptation	QoS Attribute	Notes
1.2 kbit/s	Asynch	UDI / RDI	V.120	NT	Note 2
2.4 kbit/s	Asynch	UDI / RDI	V.120	NT	Note 2
4.8 kbit/s	Asynch	UDI / RDI	V.120	NT	Note 2
9.6 kbit/s	Asynch	UDI / RDI	V.120	NT	
14.4 kbit/s	Asynch	UDI / RDI	V.120	NT	
19.2 kbit/s	Asynch	UDI / RDI	V.120	NT	
28.8 kbit/s	Asynch	UDI / RDI	V.120	NT	Note 1
38.4 kbit/s	Asynch	UDI / RDI	V.120	NT	
48 kbit/s	Asynch	UDI / RDI	V.120	NT	
56 kbit/s	Asynch	UDI	V.120	NT	

NOTE 1: Requires a new code point in V.120 specification to be defined.

NOTE 2: In case of UTRAN the user rates 1200, 2400 and 4800 bit/s toward the fixed network can be provided only for asynchronous non-transparent (NT) mobile terminated calls.

### 3.1.1.2.3 BS 20 non-transparent for PIAFS

Fixed Network User Rate	Access Structure	Information Transfer Capability	Rate Adaptation	QoS Attribute	Notes
32 kbit/s	Asynch	UDI	PIAFS	NT	
64 kbit/s	Asynch	UDI	PIAFS	NT	

### 3.1.1.2.4 BS 20 non-transparent for Frame Tunnelling Mode

Fixed Network User Rate	Access Structure	Information Transfer Capability	Rate Adaptation	QoS Attribute	Notes
56kbit/s	Asynch	RDI	X.31 flag stuffing	NT	
64 kbit/s	Asynch	UDI	X.31 flag stuffing	NT	

### 3.1.1 BS 30 (synchronous services)

#### 3.1.2.1 BS 30 T (transparent synchronous services)

##### 3.1.2.1.1 BS 30 transparent in regular mode for analogue interworking

Fixed Network User Rate	Access Structure	Information Transfer Capability	QoS attributes	Note
1.2 kbit/s	Synch	3,1 kHz	T	Notes 1 and 2
2.4 kbit/s	Synch	3,1 kHz	T	Notes 1 and 2
4.8 kbit/s	Synch	3,1 kHz	T	Notes 1 and 2
9.6 kbit/s	Synch	3,1 kHz	T	Note 2
14.4 kbit/s	Synch	3,1 kHz	T	Note 2
19.2 kbit/s	Synch	3,1 kHz	T	Note 2
28.8 kbit/s	Synch	3,1 kHz	T	

NOTE 1: These services are also supported by the GSM Phase 2 Specifications.

NOTE 2: Only applicable in GSM.

##### 3.1.2.1.2 BS 30 transparent in regular mode for digital interworking

Fixed Network User Rate	Access Structure	User Information Layer 1 protocol	QoS Attribute	Notes
1.2 kbit/s	Synch	V.110	T	Note 1 and 2
2.4 kbit/s	Synch	V.110	T	Note 1 and 2
4.8 kbit/s	Synch	V.110	T	Note 1 and 2
9.6 kbit/s	Synch	V.110	T	Note 1 and 2
14.4 kbit/s	Synch	V.110	T	Note 2
19.2 kbit/s	Synch	V.110	T	Note 2
28.8 kbit/s	Synch	V.110	T	Note 2
38.4 kbit/s	Synch	V.110	T	Note 2
48 kbit/s	Synch	V.110	T	Note 2
56 kbit/s	Synch	V.110	T (in a 64 kbit/s environment)	

NOTE 1: These services are also supported by the GSM Phase 2 Specifications.

NOTE 2: Only applicable in GSM

Fixed Network User Rate	Access Structure	User Information Layer 1 protocol	QoS Attribute	Notes
56 kbit/s	Synch	Bit transparent	T (RDI) (in a 56 kbit/s environment)	
64 kbit/s	Synch	Bit transparent	T (UDI) (in a 64 kbit/s environment)	

## 3.1.2.1.3 BS 30 transparent for Multimedia

Fixed Network User Rate	Access Structure	Information Transfer Capability	Rate Adaptation	QoS Attribute	Notes
28.8 kbit/s	Synch	3.1kHz Audio	H.223 & H.245	T	
32.0 kbit/s	Synch	UDI	H.223 & H.245	T	
33.6 kbit/s	Synch	3.1kHz Audio	H.223 & H.245	T	Note
56 kbit/s	Synch	RDI	H.223 & H.245	T	
64 kbit/s	Synch	UDI	H.223 & H.245	T	

NOTE: 33.6kbit/s FNURs is applicable only for UTRAN.

## Annex A (informative): Change history

Change history											
TSG SA#	SA Doc.	SA1 Doc	Spec	CR	Rev	Rel	Cat	Subject/Comment	Old	New	WI
Jun 1999			02.02					Transferred to 3GPP SA1	8.0.0	3.0.0	
SP-05	SP-99479	S1-99608	22.002	001		R99	D	Editorial changes for alignment	3.0.0	3.1.0	
SP-05	SP-99446	S1-99659	22.002	002		R99	B	Bearer Services	3.0.0	3.1.0	
SP-06	SP-99520	S1-991008	22.002	003		R99	B	Addition of new general bearer service user data characteristics for 33.6kbit/s modem, FTM and multimedia calls	3.1.0	3.2.0	
SP-06	SP-99520	S1-991075	22.002	004		R99	C	22.002 made only applicable to CS Domain.	3.1.0	3.2.0	
SP-07	SP-000054	S1-000132	22.002	005		R99	F	Corrections on 3,1 kHz Audio support	3.2.0	3.3.0	
SP-08	SP-000192	S1-000274	22.002	006		R99	F	Lower User Rates in UMTS for Circuit Switched Data Services	3.3.0	3.4.0	
SP-09	SP-000371	S1-000561	22.002	007		R99	F	32 kbit/s UDI/RDI multimedia in GSM	3.4.0	3.5.0	
SP-09	SP-000390	S1-000595	22.002	008		R4	C	Deletion of bearer service BS 30 NT	3.4.0	4.0.0	
SP-11	SP-010039	S1-010253	22.002	010		Rel-4	C	CR to 22.002 clarification on Circuit Switched Bearer Services in UMTS	4.0.0	4.1.0	CS Bearers in UMTs
SP-11	SP-010040	S1-010254	22.002	011		Rel-4	D	Restructuring of 22.002	4.0.0	4.1.0	CS Bearers in UMTs
SP-11	SP-010040	S1-010266	22.002	012		Rel-4	D	Restructuring of tables in section 3.1	4.0.0	4.1.0	CS Bearers in UMTs

---

## History

<b>Document history</b>		
V4.1.0	March 2001	Publication