



TECHNICAL SPECIFICATION

**Reconfigurable Radio Systems (RRS);
Dynamic Spectrum Allocation Service (DSAS);
System requirements**

Reference

RTS/RRS-0159

Keywordscoordination, data base, dynamic spectrum
sharing, inter-system, intra-system**ETSI**650 Route des Lucioles
F-06921 Sophia Antipolis Cedex - FRANCE

Tel.: +33 4 92 94 42 00 Fax: +33 4 93 65 47 16

Siret N° 348 623 562 00017 - APE 7112B
Association à but non lucratif enregistrée à la
Sous-Préfecture de Grasse (06) N° w061004871

Important notice

The present document can be downloaded from the
[ETSI Search & Browse Standards](#) application.

The present document may be made available in electronic versions and/or in print. The content of any electronic and/or print versions of the present document shall not be modified without the prior written authorization of ETSI. In case of any existing or perceived difference in contents between such versions and/or in print, the prevailing version of an ETSI deliverable is the one made publicly available in PDF format on [ETSI deliver](#) repository.

Users should be aware that the present document may be revised or have its status changed,
this information is available in the [Milestones listing](#).

If you find errors in the present document, please send your comments to
the relevant service listed under [Committee Support Staff](#).

If you find a security vulnerability in the present document, please report it through our
[Coordinated Vulnerability Disclosure \(CVD\)](#) program.

Notice of disclaimer & limitation of liability

The information provided in the present deliverable is directed solely to professionals who have the appropriate degree of experience to understand and interpret its content in accordance with generally accepted engineering or other professional standard and applicable regulations.

No recommendation as to products and services or vendors is made or should be implied.

No representation or warranty is made that this deliverable is technically accurate or sufficient or conforms to any law and/or governmental rule and/or regulation and further, no representation or warranty is made of merchantability or fitness for any particular purpose or against infringement of intellectual property rights.

In no event shall ETSI be held liable for loss of profits or any other incidental or consequential damages.

Any software contained in this deliverable is provided "AS IS" with no warranties, express or implied, including but not limited to, the warranties of merchantability, fitness for a particular purpose and non-infringement of intellectual property rights and ETSI shall not be held liable in any event for any damages whatsoever (including, without limitation, damages for loss of profits, business interruption, loss of information, or any other pecuniary loss) arising out of or related to the use of or inability to use the software.

Copyright Notification

No part may be reproduced or utilized in any form or by any means, electronic or mechanical, including photocopying and microfilm except as authorized by written permission of ETSI.

The content of the PDF version shall not be modified without the written authorization of ETSI.

The copyright and the foregoing restriction extend to reproduction in all media.

© ETSI 2026.
All rights reserved.

Contents

Intellectual Property Rights	4
Foreword.....	4
Modal verbs terminology.....	4
Introduction	4
1 Scope	6
2 References	6
2.1 Normative references	6
2.2 Informative references.....	7
3 Definition of terms, symbols, and abbreviations.....	7
3.1 Terms.....	7
3.2 Symbols.....	7
3.3 Abbreviations	7
4 Requirement organization	8
4.1 Requirement organization	8
5 System overview	9
5.1 System functional architecture	9
5.2 Spectrum Data Base (SDB).....	9
5.3 Communication between SDB, DSAS, and S3D	12
5.4 Certified S3D-Installer Data Base (CDB)	13
5.5 Optional DSAS - NRA interface	14
6 Inter-system Coordination (INC)	14
6.1 Functional requirements for inter-system coordination.....	14
6.1.1 Device registration and spectrum inquiry	14
6.1.2 Geolocation capability	15
6.1.3 Device power and emission limits	16
6.1.4 Security requirements	16
6.1.5 Primary user protection.....	16
6.1.6 Optional requirements for inter-system coordination	16
6.2 Technical requirements for inter-system coordination	17
7 Intra-system Coordination (IRC).....	17
7.1 Additional functional requirements for intra-system coordination.....	17
7.1.1 Non-primary user coordination.....	17
7.1.2 Optional requirements for intra-system coordination	18
7.2 Additional technical requirements for intra-system coordination	18
7.2.1 Introduction of NPU coordination requirements.....	18
8 Handover process between multiple DSAS	19
8.1 Scenarios	19
8.2 Multiple DSAS per zone	20
8.2.1 Open-loop INC	20
8.2.2 Closed-loop INC.....	21
8.2.3 Closed-loop IRC	21
8.3 Multiple DSAS of multiple zones	21
8.3.1 Open-loop INC	21
8.3.2 Closed-loop INC.....	22
8.3.3 Closed-loop IRC	22
8.4 Closed-loop data base.....	22
Annex A (informative): Bibliography.....	23
History	24

Intellectual Property Rights

Essential patents

IPRs essential or potentially essential to normative deliverables may have been declared to ETSI. The declarations pertaining to these essential IPRs, if any, are publicly available for **ETSI members and non-members**, and can be found in ETSI SR 000 314: "*Intellectual Property Rights (IPRs); Essential, or potentially Essential, IPRs notified to ETSI in respect of ETSI standards*", which is available from the ETSI Secretariat. Latest updates are available on the [ETSI IPR online database](#).

Pursuant to the ETSI Directives including the ETSI IPR Policy, no investigation regarding the essentiality of IPRs, including IPR searches, has been carried out by ETSI. No guarantee can be given as to the existence of other IPRs not referenced in ETSI SR 000 314 (or the updates on the ETSI Web server) which are, or may be, or may become, essential to the present document.

Trademarks

The present document may include trademarks and/or tradenames which are asserted and/or registered by their owners. ETSI claims no ownership of these except for any which are indicated as being the property of ETSI, and conveys no right to use or reproduce any trademark and/or tradename. Mention of those trademarks in the present document does not constitute an endorsement by ETSI of products, services or organizations associated with those trademarks.

DECT™, **PLUGTESTS™**, **UMTS™** and the ETSI logo are trademarks of ETSI registered for the benefit of its Members. **3GPP™**, **LTE™** and **5G™** logo are trademarks of ETSI registered for the benefit of its Members and of the 3GPP Organizational Partners. **oneM2M™** logo is a trademark of ETSI registered for the benefit of its Members and of the oneM2M Partners. **GSM®** and the GSM logo are trademarks registered and owned by the GSM Association.

Foreword

This Technical Specification (TS) has been produced by ETSI Technical Committee Reconfigurable Radio Systems (RRS).

Modal verbs terminology

In the present document "**shall**", "**shall not**", "**should**", "**should not**", "**may**", "**need not**", "**will**", "**will not**", "**can**" and "**cannot**" are to be interpreted as described in clause 3.2 of the [ETSI Drafting Rules](#) (Verbal forms for the expression of provisions).

"**must**" and "**must not**" are **NOT** allowed in ETSI deliverables except when used in direct citation.

Introduction

The Dynamic Spectrum Allocation Service (DSAS) manages spectrum access for non-primary users in frequency bands in which spectrum sharing is applied. DSAS guarantees interference-free operation for the primary users and offers dynamic spectrum access for non-primary users based on a situational assessment of the actual spectrum demand and on-site spectrum occupation. Furthermore, the following scheme can be used for co-primary allocation and coordination with the goal of effectively sharing band with guaranteed QoS.

In ETSI TR 103 885 [i.1], several use cases for temporary and flexible spectrum access are analysed and their requirements are compared with existing spectrum sharing frameworks. The results are used as the basis for the system requirements of the dynamic spectrum allocation service. The requirements are split into two categories:

- functional requirements that describe system behaviour under specific conditions and contain aspects of the end user expectations;
- technical requirements that describe the features and characteristics of the system that ensure pre-defined output performance and system's quality.

1 Scope

The present document specifies system requirements for the Dynamic Spectrum Allocation Service (DSAS) to support dynamic, temporary, and flexible spectrum sharing in an efficient, automated, and frequency and technology agnostic way based on the analysis introduced in ETSI TR 103 885 [i.1]. The report considers existing systems such as Automated Frequency Coordination (AFC), evolved License Shared Access (eLSA), or Citizens Broadband Radio Service Spectrum Access System (CBRS SAS), which could need to be adapted or simplified instead of developing a new system from scratch. It outlines which features of the previously mentioned systems can be removed, because they are unnecessary in the context of the intended use cases, and which features need to be added to fill identified gaps. In addition, the frequency ranges currently covered by AFC, eLSA, and CBRS SAS will be extended to other frequency ranges.

Functional and technical requirements of the DSAS are described and defined for two different coordination approaches:

- **Inter-system Coordination (INC):** a sharing framework between different communication systems, in which Primary Users (PU) of the relevant frequency bands are protected against all users of lower tiers (i.e. Non-Primary Users (NPU)). NPUs access is granted without any guaranteed level of Quality of Service (QoS). When only INC is enforced, NPUs may be requested to change their RF parameters and their overall system performance during their operation time. INC is comparable with the determination of available channels and its operational parameters on which a NPU device is allowed to operate at its geographic coordinates.
- **Intra-system Coordination (IRC):** a sharing framework in which PUs of the relevant frequency bands get protected against all user of lower tiers (NPUs) and NPUs are getting coordinated to minimize interference between them and to guarantee a certain level of QoS. The level of QoS experienced by the NPUs depends on its prioritization, the current demand for spectrum, the neighbouring situation, and maybe the price the user is willing to pay. IRC is comparable with a channel assignment/licensing including its operational parameters to NPU devices at its geographic coordinates.

The requirements captured in the present document are described in a technology neutral manner and are applicable for any wireless technology. DSAS enables dynamic spectrum sharing in any frequency band that is assigned for coordinated sharing.

2 References

2.1 Normative references

References are either specific (identified by date of publication and/or edition number or version number) or non-specific. For specific references, only the cited version applies. For non-specific references, the latest version of the referenced document (including any amendments) applies.

Referenced documents which are not found to be publicly available in the expected location might be found in the [ETSI docbox](#).

NOTE: While any hyperlinks included in this clause were valid at the time of publication, ETSI cannot guarantee their long-term validity.

The following referenced documents are necessary for the application of the present document.

Not applicable.

2.2 Informative references

References are either specific (identified by date of publication and/or edition number or version number) or non-specific. For specific references, only the cited version applies. For non-specific references, the latest version of the referenced document (including any amendments) applies.

NOTE: While any hyperlinks included in this clause were valid at the time of publication, ETSI cannot guarantee their long-term validity.

The following referenced documents may be useful in implementing an ETSI deliverable or add to the reader's understanding, but are not required for conformance to the present document.

[i.1] ETSI TR 103 885 (V1.1.2): "Reconfigurable Radio Systems (RRS); Feasibility study on existing spectrum sharing frameworks for temporary and flexible spectrum access".

3 Definition of terms, symbols, and abbreviations

3.1 Terms

Void.

3.2 Symbols

For the purposes of the present document, the following symbols apply:

dB	decibel
dBm	decibel-milliwatt
dBm/kHz	decibel-milliwatt per kilohertz
f_c	centre frequency
GHz	gigahertz
h	hour
kHz	kilohertz
MHz	megahertz
m	meter
min	minute
mW	milliwatt

3.3 Abbreviations

For the purposes of the present document, the following abbreviations apply:

AFC	Automated Frequency Coordination
B	channel Bandwidth
CBRS	Citizens Broadband Radio Service
CDB	Certified S3D-Installer Data Base
CR	Coordination Requirement
CSI	Certified S3D-Installer
CSI-ID	Certified S3D-Installer Identifier
DGR	Device General Requirement

NOTE: Shared spectrum service.

DL	Downlink
DSAS	Dynamic Spectrum Allocation Service
DSQ	Device Security reRequirement

NOTE: Shared spectrum service.

EIRP	Effective Isotropic Radiated Power
eLSA	evolved Licensed Shared Access
FR	Functional Requirement
GB	Guard Band
I/N	Interference to Noise ratio
INC	Inter-system Coordination
IRC	Intra-system Coordination
ISM	Industrial, Scientific and Medical
LAA	Limited Application Area
LAC	Limited Application Channel
LBT	Listen Before Talk
NPU	Non-Primary User
NRA	National Regulatory Administration
OOB	Out-Of-Band
OP	Operational Parameter
PU	Primary User
QoS	Quality of Service
RF	Radio Frequency
S3D	Spectrum Sharing Service Device
SAS	Spectrum Access System
SDB	Spectrum Data Base
SDB-L1	Spectrum Data Base Level 1
SDB-L2	Spectrum Data Base Level 2
SDB-L3	Spectrum Data Base Level 3
SGR	DSAS System General Requirement
SNP	DSAS System Non-primary user Protection
SPP	DSAS System Primary user Protection
SSQ	DSAS System Security reRequirement
TR	Technical Requirement
UL	Uplink

4 Requirement organization

4.1 Requirement organization

Requirements shall be uniquely identified by: <TYPE>R-<COORDINATION>-<CATEGORY>-<XX>-<Y> with:

- <TYPE>: identifier of the requirement type.

Table 1: Requirements type

Code	Requirement type
F	Functional requirement
T	Technical requirement

- <COORDINATION>: identifier of the coordination approach.

Table 2: Coordination approach

Code	Coordination approach
INC	Inter-system coordination
IRC	Intra-system coordination

- <CATEGORY>: categorization of the requirement by using a three-digit code from Table 3.

Table 3: Requirements categorization

Code	Category
DGR	Shared spectrum service device general requirement
DSQ	Shared spectrum service device security requirement
SGR	DSAS system general requirement
SSQ	DSAS system security requirement
SPP	DSAS system primary user protection
SNP	DSAS System Non-primary user Protection

- <XX>: unique number to identify the requirement.
- <Y>: optional and used to identify subordinate requirements, typically captured in an alphabetical list.

5 System overview

5.1 System functional architecture

An overview of the functional architecture of a DSAS system is shown in Figure 1. It includes related interfaces that need to be specified, such as DSAS-SDB interface between DSAS and Spectrum Data Base (SDB), DSAS-S3D interface between DSAS and Shared Spectrum Service Device (S3D), DSAS-CDB interface between DSAS and the data base of Certified S3D-Installers (CDB), as well as an arbitrary interface that is not in scope of the present document. There may be cases where a link to multiple SDBs is required, e.g. in national border areas. This should also be supported.

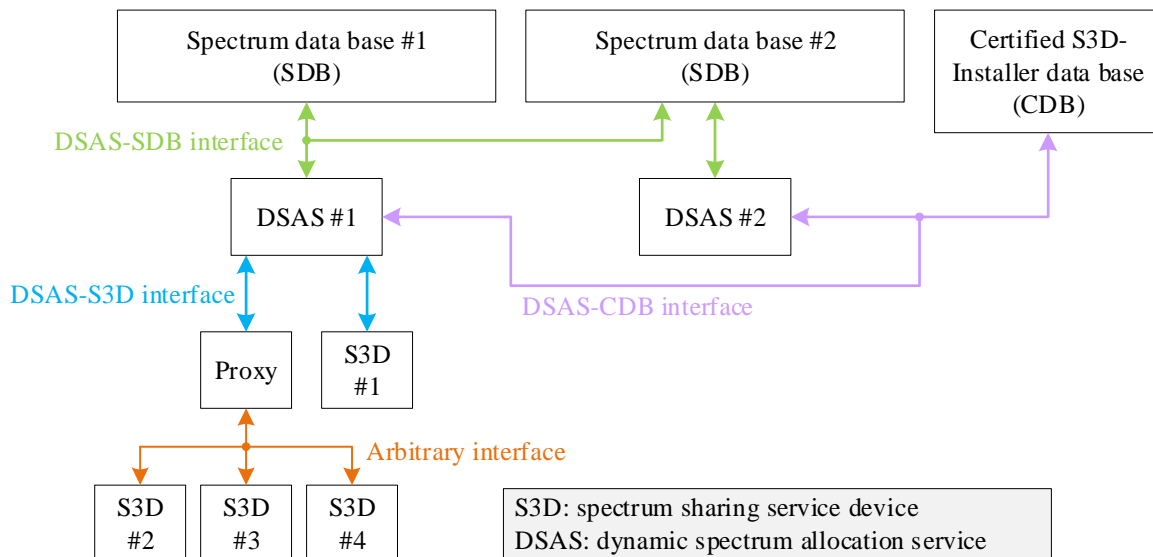

Figure 1: Functional architecture for spectrum sharing

The DSAS is located between the end user (here S3D) and the two data bases SDB and CDB and provides information on the available spectrum including its restrictions to the end user and determines the validity of the S3D license.

5.2 Spectrum Data Base (SDB)

Each DSAS shall be connected to at least one SDB, connections to multiple SDBs can be required in case of e.g. cross-national operation.

In general, the SDB supports the following different levels:

- a first level containing information on the relevant primary users (SDB-L1):
 - required for protecting the PUs (INC).
- a second level containing information on the temporarily active non-primary users (SDB-L2):
 - required only in case of coordinating the NPU (IRC) otherwise optional;
 - possible implementation of SDB-L2 could be a logical function within the DSAS (hence enabling a DSAS to DSAS interface).
- a third level containing additional information on the PUs and/or NPUs, e.g. antenna patterns, operating time (SDB-L3):
 - optional;
 - possible implementation of SDB-L3 could be a logical function within the DSAS.

Figure 2 and Figure 3 depict this approach. Each of these levels can have several instances, e.g. there could be a second level SDB for each region.

Every second level SDB needs to be registered at the corresponding NRA who stores this information in the first level SDB. The sequence of steps (step 1 to step 5) in the communication flow between SDB and DSAS is shown in Figure 3. Depending on the number of existing first and second level SDBs step 1 to step 5 has to be repeated accordingly. Like the three levels of SDB the interface between DSAS and SDB is divided into three parts:

- level 1 interface: read-only access to SDB-L1;
- level 2 interface: read-write access to SDB-L2;
- level 3 interface: read-only access to SDB-L3.

The first level of SDB is always mandatory, the second level is mandatory only if IRC is supported to enable coordination of NPUs and to calculate aggregate interference, the third level is optional.

National Regulatory Administrations (NRA) may be responsible to manage and update the first level SDB using a centralized data base. The second level SDB as well as the third level SDB could be also implemented in a centralized data base managed by NRA or a third party, or could be realized as a decentralized approach, i.e. it contains only information on the locally active NPUs e.g. as part of the local DSAS, or as local stand-alone data base managed by a service provider.

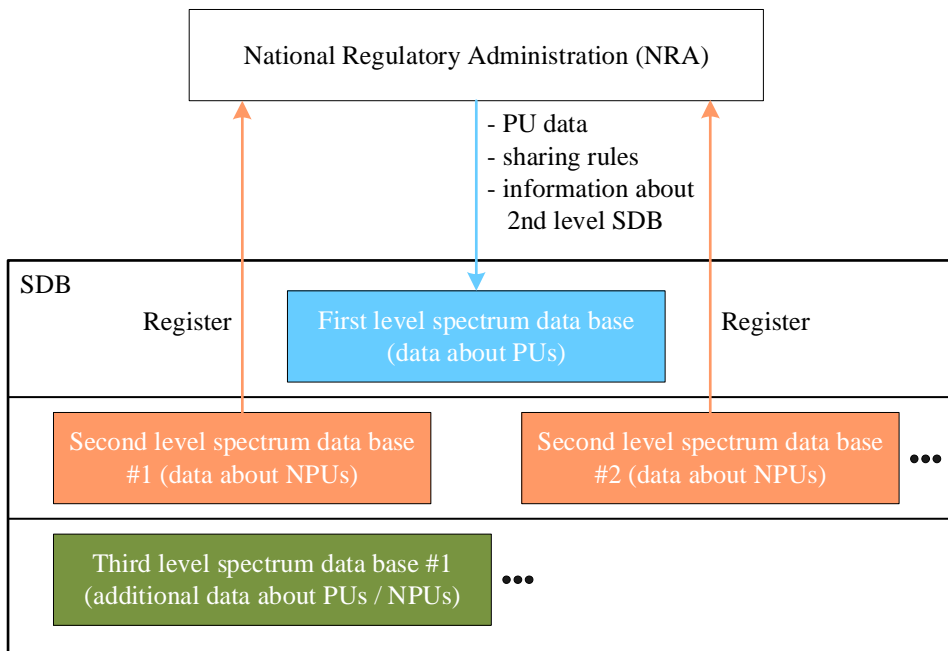
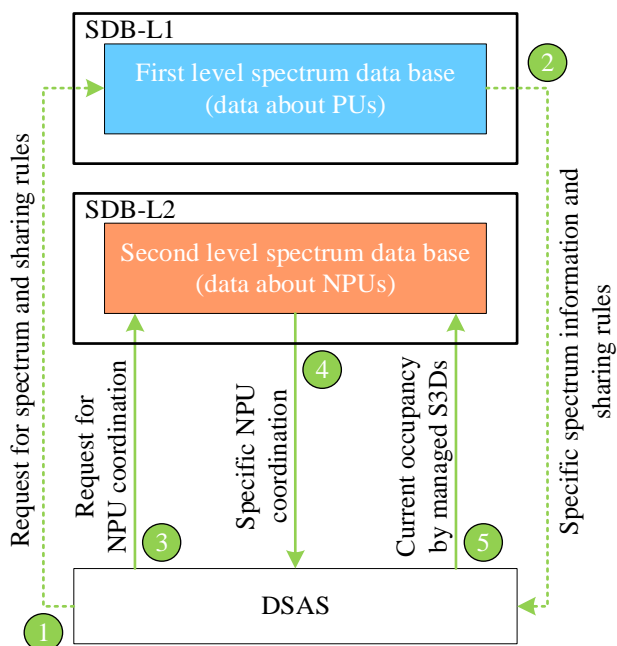

Figure 2: 3-level architecture of the SDB



DSAS-SDB interface:

- ←----- Read-only access – level 1 interface
- ←----- Read-write access – level 2 interface

Figure 3: Communication between SDB and DSAS

5.3 Communication between SDB, DSAS, and S3D

Depending on the required coordination solution (INC or IRC), the general workflow is based on either one or two steps. The first step is always related to the INC (see Figure 4). The outcome of the first step (INFO1) is the information about available channels and their required operational parameters. INFO1 carries a set of channels that can be used by the S3D for its operation with the relative operational parameters. The goal of this message is to guarantee the secure operation of the primary users and does not include any information about other non-primary band occupiers.

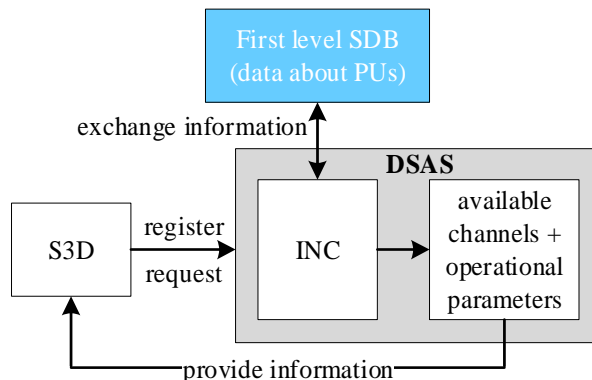

Figure 4: INC workflow

The second step is related to IRC (see Figure 5) and has the goal to achieve interference-free or interference-reduced operation of the non-primary users. Its outcome, if it is supported, is indicated in the message INFO2, and it is the assignment of a dedicated channel including its required operational parameters.

In the case in which only INFO1 is transmitted to the S3D, the S3D has the freedom to choose any of the proposed channels, in case in which INFO2 is provided it contains a mandatory channel to be used for the S3D operation.

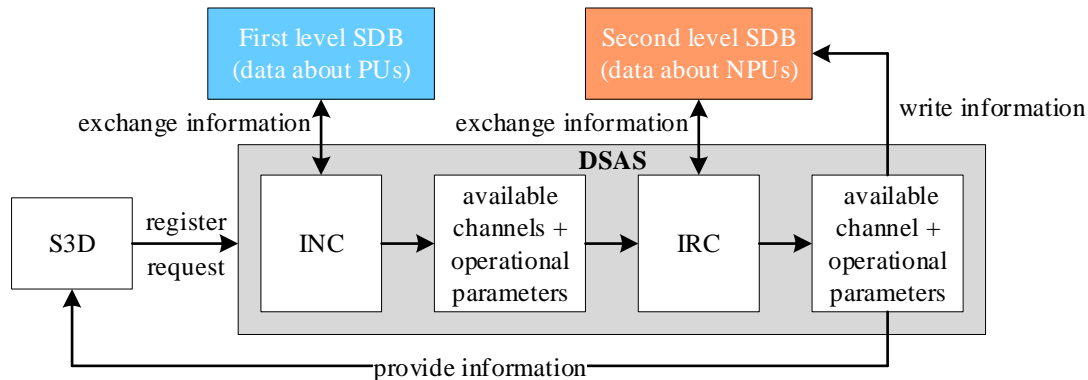

Figure 5: IRC workflow

In general, there are two different ways of communication between DSAS and S3D: open loop and closed loop, which are described in Table 4.

Table 4: Communication loops between DSAS and S3D

DSAS - S3D communication loop	Description
open	<ul style="list-style-type: none"> • DSAS informs S3D about available channel(s) and OPs. • S3D does not report which channel(s) and OPs it uses. • DSAS does not calculate aggregate interference.
closed	<ul style="list-style-type: none"> • DSAS informs S3D about available channel(s) and OPs. • S3D reports current channel occupation and corresponding OPs: <ul style="list-style-type: none"> – it may include backup channels that are used only in case of interference. • DSAS shall calculate aggregate interference according to the current channel occupation. • S3D may regularly report the interference levels of channels monitored by S3D during operation.

In case of INC, all two types of communication loops can be implemented, whereas the closed loop is required for IRC.

Which loop is required depends on the regulation of the specific frequency band and the DSAS communicates it to the requesting S3D.

5.4 Certified S3D-Installer Data Base (CDB)

In addition to the spectrum data base, a second data base, the Certified S3D-Installer Data Base (CDB), is needed to store and manage data of Certified S3D-Installers (CSI). After successful certification every CSI gets a unique Certified S3D-Installer ID (CSI-ID) from the operator of that data base that is needed for all further connectivity with DSAS.

Before DSAS provides information on the available spectrum to a requesting S3D, it has to verify the validity of the CSI-ID of the installer/user of the requesting S3D.

The minimum set of certification data contains the data listed in Table 5.

Table 5: CDB minimum data set

Field	Field description
CSI-ID	Unique ID assigned to the CSI by CDB operator
CSIname	Name of the CSI
CSIaddress	Contact address of the CSI
CSIlegal	Legal address of the CSI
CSIemail	Email address of the CSI
CSIphone	Phone number of the CSI
CSIstart	Starting date of the CSI certification
CSIend	Expiration date of the CSI certification

After registering in the CDB, the CSI shall receive information about available DSASs including:

- the covered geographical area;
- the managed spectrum ranges;
- whether a DSAS - NRA interface is available.

5.5 Optional DSAS - NRA interface

In case of a closed communication loop, DSAS may report back to the NRA which frequencies including their OPs are used by which CSI.

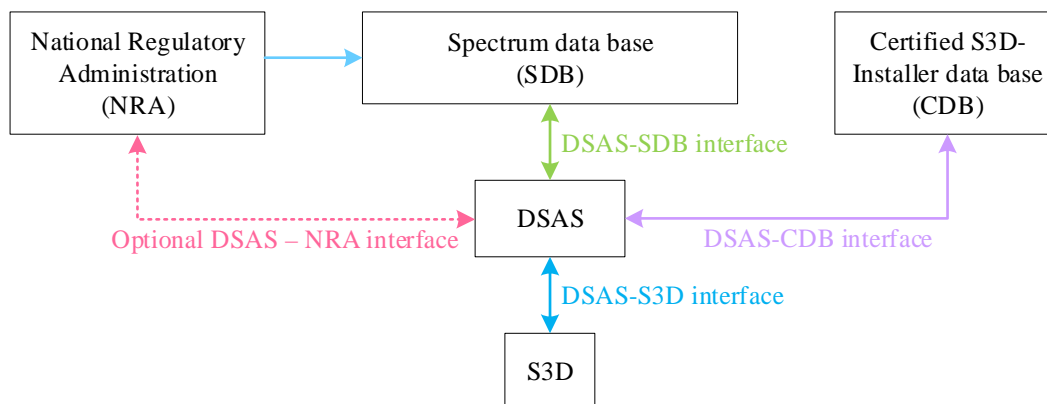

Figure 6: Optional DSAS-NRA interface

For that purpose, an additional interface between DSAS and NRA is needed (see Figure 6). This is an optional interface that is only implemented if it is required by the NRA.

This interface could also be used to assign individual licenses to requesting S3Ds via DSAS without any additional coordination by DSAS.

6 Inter-system Coordination (INC)

6.1 Functional requirements for inter-system coordination

6.1.1 Device registration and spectrum inquiry

FR-INC-DGR-01: Device registration requirements:

- a) S3D shall register with and be authorized by a DSAS system prior to its initial service transmission or after a location change.
- b) S3D shall register with the DSAS system by providing the following parameters:
 - i) geographic coordinates (latitude and longitude);
 - ii) operation time;
 - iii) unique CSI-ID and shall provide updated parameters to the DSAS if any of these parameters change.

Depending on the DSAS demand S3D shall provide further antenna information e.g.: antenna height, antenna pattern, and/or antenna gain.

- c) S3Ds shall provide the registration information to the DSAS either directly and individually or by a network element (proxy) representing multiple S3Ds from the same network.

FR-INC-DGR-02: S3D shall transmit only on frequencies and at power levels that DSAS indicates as available.

FR-INC-DGR-03: S3D shall access DSAS to determine the available frequencies and the corresponding maximum permissible power levels at their geographic coordinates prior to transmitting.

FR-INC-DGR-04: S3D shall request the latest list of available frequencies and the maximum permissible power level from DSAS according to the time interval specified in TR-INC-DGR-01 (heartbeat signal).

FR-INC-DGR-05: When contacting DSAS in accordance with FR-INC-DGR-04, S3D shall query DSAS for a frequency range with specifying a channel bandwidth across which it will operate and the maximum envisaged output power.

FR-INC-DGR-06: When S3D does not get a replay from DSAS after N numbers of attempts of sending its heartbeat signal according to FR-INC-DGR-04, S3D shall stop all transmissions. N is specified in TR-INC-DGR-04 and may vary for different frequency ranges or different applications/services.

FR-INC-DGR-07: When the expiration date is passed, S3D shall stop all transmissions.

FR-INC-DGR-08: In case of a semi-closed or closed communication loop, S3D shall report current channel occupation and corresponding OPs including backup channels in semi-closed operation.

FR-INC-SGR-01: DSAS shall verify the validity of the unique CSI-ID of any S3D seeking access to the DSAS prior to authorizing it.

FR-INC-SGR-02: DSAS shall register, authenticate, and authorize S3D operations individually or through a network element device (proxy) that represents multiple S3Ds from the same network.

FR-INC-SGR-03: DSAS shall be capable to determine the available frequencies in accordance with the given channel raster and the applicable output power limits to protect the PUs from a S3D at any given location according to the precalculated exclusion zones.

FR-INC-SGR-04: DSAS shall respond to S3D's register and access inquiry within the time specified in TR-INC-SGR-05.

FR-INC-SGR-05: DSAS shall consider location uncertainty reported by S3D to determine maximum acceptable power levels to protect PUs.

FR-INC-SGR-06: DSAS responding to the request of S3D in accordance with FR-INC-DGR-05 shall identify the allowed channel bandwidth. The provided values shall be in the range between TR-INC-SGR-06 and TR-INC-SGR-07.

FR-INC-SGR-07: DSAS responding to the request of S3D in accordance with FR-INC-DGR-05 shall identify maximum allowed power spectral density and EIRP for each specified channel bandwidth. The provided values shall not exceed limits specified in TR-INC-DGR-03 and TR-INC-SGR-02.

FR-INC-SGR-08: DSAS responding to the request of S3D in accordance with FR-INC-DGR-05 shall identify and provide an expiration date for the requested frequency range.

FR-INC-SGR-09: DSAS shall obtain updated information from the spectrum data base according to the time interval specified in TR-INC-SGR-04.

FR-INC-SGR-10: DSAS responding to the request of S3D in accordance with FR-INC-DGR-05 shall provide which coordination (INC or IRC) is required and which communication loop is implemented,

FR-INC-SGR-11: DSAS shall report to requesting S3D whether an interface between DSAS and NRA is available.

6.1.2 Geolocation capability

FR-INC-DGR-06: Geolocation capability requirements:

- a) S3D shall report its geographic coordinates and location uncertainty to DSAS during the registration process and every time it changes its location.
- b) When using an external geolocation source, the separation distance between such source and S3D shall be included in the location uncertainty.
- c) A single geolocation source may provide location information to multiple S3Ds.
- d) The accuracy of the location information shall be in the range specified by TR-INC-DGR-02.

6.1.3 Device power and emission limits

FR-INC-DGR-09: Device output power

- a) The maximum power spectral density shall not exceed the limit specified in TR-INC-DGR-03.
- b) The maximum EIRP over the applied frequency band of operation shall not exceed the limit specified in TR-INC-DGR-04.

FR-INC-DGR-10: The OOB emissions that fall into the range between $f_c + B/2 < f < f_c + 2,5 \cdot B$ and $f_c - B/2 > f > f_c - 2,5 \cdot B$ with B = channel bandwidth and f_c = channel's centre frequency shall not exceed the limits specified in TR-INC-DGR-05.

FR-INC-DGR-11: Spurious emissions in the range $f > f_c + 2,5 \cdot B$ and $f < f_c - 2,5 \cdot B$ with B = channel bandwidth and f_c = channel's centre frequency shall not exceed the limits specified in TR-INC-DGR-06.

6.1.4 Security requirements

FR-INC-DSQ-01: S3D shall incorporate adequate security mechanisms to prevent it from accessing DSAS systems not approved by the corresponding national regulatory body.

FR-INC-DSQ-02: S3D shall incorporate adequate security mechanisms to ensure secure communications between S3D and DSAS system to prevent corruption or unauthorized interception of data.

FR-INC-DSQ-03: S3D shall use for the purpose of communications with a DSAS system the protocols specified in TR-INC-DSQ-01.

FR-INC-SSQ-01: DSAS shall incorporate adequate security mechanisms to ensure secure communications between S3D and DSAS system to prevent corruption or unauthorized interception of data.

FR-INC-SSQ-02: DSAS shall use for the purpose of communications with a S3D the protocols specified in TR-INC-DSQ-01.

6.1.5 Primary user protection

FR-INC-SPP-01: DSAS shall protect multiple PU services from harmful interference during their time of operation.

FR-INC-SPP-02: DSAS shall establish location and frequency-based exclusion zones around PUs operating in the shared spectrum. The spectral width of the exclusion zone is specified in TR-INC-SPP-01.

FR-INC-SPP-03: DSAS shall use the interference protection criteria specified in TR-INC-SPP-03 to determine the size of the exclusion zone.

FR-INC-SPP-04: To calculate protection zones, DSAS shall use the propagation model and parameter specified in TR-INC-SPP-04.

6.1.6 Optional requirements for inter-system coordination

FR-INC-DGR-06: When contacting DSAS in accordance with FR-INC-DGR-04, S3D may report to DSAS measured interference levels in channels monitored by S3D during operation. The report may include the type of the monitor process, e.g. maximum peak or average level.

FR-INC-SGR-11: DSAS may provide relevant information about other managed S3Ds to any connected S3D.

6.2 Technical requirements for inter-system coordination

The technical requirements are specified per contiguous frequency range. Each range is represented by a corresponding table. Table 6 lists the required technical parameters. The units in Table 6 do not specify the granularity of the corresponding parameter.

Table 6: Technical requirements for inter-system coordination

Identifier	Description	Unit
TR-INC-SGR-01	Frequency range managed by DSAS	MHz
TR-INC-DGR-01	Update rate of request for latest list of available frequencies and maximum power levels (heartbeat signal between S3D and DSAS)	s
TR-INC-DGR-02	Maximum location uncertainty	m
TR-INC-DGR-03	Maximum allowed power spectral density	dBm/kHz
TR-INC-DGR-04	Maximum number of missing heartbeat signals	-
TR-INC-SGR-02	Maximum allowed EIRP per channel	dBm
TR-INC-SGR-03	Channel raster	MHz
TR-INC-SGR-04	Update rate information exchange between DSAS and SDB	s
TR-INC-SGR-05	DSAS response time to S3D request	s
TR-INC-SGR-06	Minimum supported channel bandwidth (B)	MHz
TR-INC-SGR-07	Maximum supported channel bandwidth	MHz
TR-INC-DGR-05	Corner of OOB emission limits: e.g. f_c $\pm B/2$ $\pm B$ $\pm 2,5 B$	dBm/kHz
TR-INC-DGR-06	Emission limits within spurious domain	dBm/kHz
TR-INC-SPP-01	Spectral width of exclusion zone: e.g. co-channel + adjacent channel + guard band	MHz
TR-INC-SPP-02	Guard band of exclusion zone (GB)	MHz
TR-INC-SPP-03	Interference protection criteria (e.g. I/N)	dB
TR-INC-SPP-04	Propagation model and parameters	-

7 Intra-system Coordination (IRC)

7.1 Additional functional requirements for intra-system coordination

7.1.1 Non-primary user coordination

FR-IRC-DGR-01: After receiving the response in accordance with FR-INC-SGR-12, S3D shall report its required Coordination Requirements (CRs) to the DSAS.

FR-IRC-DGR_02: After receiving an acknowledge in accordance with FR-IRC-SGR-01, S3D shall operate in accordance with the relevant CRs.

FR-IRC-DGR-03: After receiving a negative acknowledge in accordance with FR-IRC-SGR-01, S3D shall either stop requesting or retransmit the required CRs updated by the response of DSAS.

FR-IRC-SGR-01: DSAS responding to S3D in accordance with FR-IRC-DGR-01 shall response in case all requested CRs can be provided with an acknowledge or in case all requested CRs cannot be provided with a negative acknowledge including the required CRs that cannot be provided.

FR-IRC-SNP-01: After sending an acknowledge in accordance with FR-IRC-SGR-01, DSAS shall operate in accordance with the relevant CRs.

FR-IRC-SNP-02: DSAS shall be capable to ensure coordination of NPUs in accordance with the given restrictions, the requested CRs, and the current sharing situation and to determine the available channel and its OPs or channels and their OPs in case of a semi-closed loop.

7.1.2 Optional requirements for intra-system coordination

Only in case of a S3D with cognitive functionalities, e.g. local spectrum scanning, the following optional requirements apply:

FR-IRC-DGR-08: S3D may report to the connected DSAS the result of its own coordination calculation.

FR-IRC-DGR-09: S3D may operate according to parameters based on its own coordination only if DSAS authorizes the operation.

Only if a DSAS - NRA interface is available, the following requirements apply:

FR-IRC-SGR-02: NRA may require the connected DSAS to report the frequencies including their OPs are used and the corresponding CSI.

FR-IRC-SGR-03: DSAS responding in accordance with FR-IRC-SGR-02 shall report to the connected NRA the frequencies including their OPs are used and the corresponding CSI.

FR-IRC-SNP-03: DSAS may request available individual licenses from connected NRA.

FR-IRC-SNP-04: After receiving a non-empty list of licenses in accordance with FR-IRC-SNP-03, DSAS shall provide a license to the requesting S3D and report the selected license back to the NRA.

FR-IRC-DGR-10: S3D shall operate according to the conditions of the license provided according to FR-IRC-SNP-04.

7.2 Additional technical requirements for intra-system coordination

7.2.1 Introduction of NPU coordination requirements

To support efficient IRC, Coordination Requirements (CRs) are defined that cover the various requirements of the NPUs and their applications. The CRs are separated into DSAS related requirements (see Table 7) and S3D related requirements (see Table 8). When asking for spectrum and coordination, the S3D reports one set of CRs that meets its requirements best. CRs relate more to the requirements on the spectrum access than to the system performance of the S3D, i.e. in most cases they are not relevant for the QoS of the application. The units in Table 7 and Table 8 do not specify the granularity of the corresponding parameter.

Table 7: Coordination requirements relating to DSAS

No.	CR	Unit	Description
CR01	DSAS authorization time	s	the maximum time required from DSAS to assign one or more channels to the requesting S3D
CR02	DSAS periodicity of heartbeat signal	s	the maximum update interval for information exchange between DSAS and S3D that DSAS supports; it defines the required heartbeat periodicity between DSAS and S3D and corresponds to the system's reaction time on environmental changes

Table 8: Coordination requirements relating to S3D

No.	CR	Unit	Description
CR03	S3D reaction time/periodicity of heartbeat signal	s	the maximum update interval for information exchange between DSAS and S3D that the requesting S3D supports; it defines the required heartbeat periodicity and the S3D's reaction time on environmental changes
CR04	UL/DL configuration	-	the ability of the requesting S3D to synchronize with co-located S3Ds, i.e. to adapt its UL/DL configuration (duty cycle); possible values are: <ul style="list-style-type: none"> fixed: no adaptation possible arbitrary: adaptable to different UL/DL schemes
CR05	Stability of channel allocation	s	the minimum time required by the S3D system to use the assigned channel without changing its OPs
CR06	Coexistence group availability	-	availability of a group of S3Ds that coordinate interference within the group according to a common interference mitigation technique; possible values are: <ul style="list-style-type: none"> no: there is no group available specific mitigation technique and its parameters supported by that group neutral: the requesting device can operate with any level of interference generated within that group
CR07	Bandwidth	MHz	the amount of spectrum the S3D system requires; it should be an integer multiple of the channel grid
CR08	Operation time	s	the maximum time in which the S3D system occupies the requested spectrum
CR09	Output power	dBm	the maximum output power which the S3D transmits during the whole operation time
CR10	Interference level	dBm/kHz	maximum level and average level of interference power that the NPU's receiver can tolerate; it is specified as interference power per channel bandwidth: <ul style="list-style-type: none"> maximum (mandatory) average (optional)
CR11	Tier level	-	integer number that indicates a prioritization between NPUs: <ul style="list-style-type: none"> 0: lowest tier level => no prioritization 1: prioritized against NPUs with tier level 0

CR03 to CR11 act as a kind of Service Level Agreement that is guaranteed for the NPU and has to be delivered by the DSAS managing the requesting NPU.

8 Handover process between multiple DSAS

8.1 Scenarios

The following two different scenarios are covered:

- handover between multiple DSAS per zone, and
- handover between multiple DSAS of multiple zones.

The first describes the case where multiple DSAS share the same zone, either completely or partially overlapping (see Figure 7).

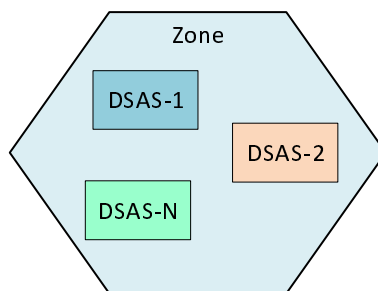

Figure 7: Multiple DSAS per zone

The second scenario supports mobile applications where both the handheld and the base station are mobile. A handover between different zones is required in case that the mobile network moves from one zone into another (see Figure 8).

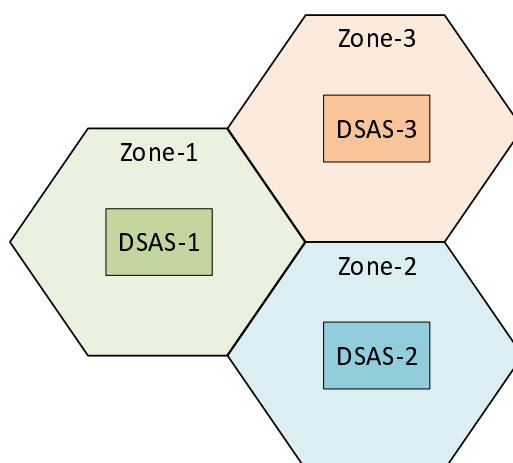

Figure 8: Multiple DSAS of multiple zones

Here, the assumption for the handover process is that each DSAS operates under the same spectrum sharing policy and S3Ds can be deployed in border regions between at least two zones, i.e. the OPs negotiated in e.g. zone 1 do not cause harmful interference in e.g. zone 2.

To support the handover process, at least the following items should be supported:

- it should be possible to indicate the mobility requirement so that not in every case mobility needs to be supported, e.g. via a mobility flag;
- the S3D needs to pre-register to all relevant neighbouring zones.

8.2 Multiple DSAS per zone

8.2.1 Open-loop INC

In case of an open loop communication, the output of INC is one or multiple Limited Application Area (LAA):

- in open loop communication no aggregate interference is calculated as S3D does not report which channel and OP it uses;
- information exchange between DSAS in one zone is not required;
- to guarantee interference free operation of PU, enough margin should be considered at PU side => only usable for low power NPU devices;
- the spectrum sharing mechanism is similar to AFC;
- in case of multiple DSAS, margins should account for possible interference generated by other systems.

8.2.2 Closed-loop INC

In case of a INC, the output is the same as in the open-loop case, but the aggregate interference is calculated.

- S3D reports current channel occupation and corresponding OPs;
- DSAS shall calculate aggregate interference according to the current channel occupation:
 - interference calculation needs data of all connected NPUs;
 - only a minimum set of data that needs to be exchanged between different DSAS is required, e.g. the calculated aggregate interference vs. time per DSAS;
 - aggregate interference information increases the efficiency of the spectrum use;
- as no secondary data base is available, following options are possible to exchange information between the different DSAS:
 - DSAS - DSAS interface:
 - adds high complexity to the system as each DSAS needs to communicate with all other DSAS, e.g. via a cloud service;
 - how to handle communication in case of one DSAS is shutdown or malfunctioning?
 - data base similar to secondary data base with read/write access for all available DSAS.

If no information exchange takes place, the following options are possible:

- the available spectrum is separated into dedicated chunks which offers the following options:
 - each DSAS manages its own portion;
 - there are portions of spectrum that are managed by dedicated DSASs and a portion that is fully shared without any DSAS operation similar to ISM;
 - the different portions offer different output power options including a threshold at which the NPU has to connect to DSAS (similar to AFC);
- only a dedicated number of S3Ds per DSAS is allowed that depends on the output power of S3Ds.

8.2.3 Closed-loop IRC

IRC is always based on close-loop communication. Output of IRC is one or more Limited Application Channel (LAC) with the corresponding OPs.

IRC needs an exchange of the full information apart from information about the certified S3D Installer. This requires a larger data base and a regular update between data base and DSAS.

Closed-loop IRC offers the highest efficiency for spectrum allocation in a dynamically shared environment.

8.3 Multiple DSAS of multiple zones

8.3.1 Open-loop INC

For inter-system coordination based on open-loop communication no data exchange between different DSASs is required. Assuming that the OPs per S3D are static or require a very low update rate only, two options are imaginable to support seamless handover:

- the S3D downloads the corresponding OPs of both zones, of the one it is currently in and of the one it will perhaps enter later, so it can change the OPs after entering the new zone;

- after entering the new zone, the S3D still operates with the previous OPs and changes the OPs after getting the valid ones of the new zone.

8.3.2 Closed-loop INC

The closed-loop INC case is similar to the open-loop case and does not require S3D data exchange between the different DSASs and the same options to support seamless handover are imaginable.

8.3.3 Closed-loop IRC

To offer a seamless handover in case of closed-loop IRC, the entire data set of the S3D concerned needs to be exchanged between the corresponding DSASs. Otherwise, the S3D needs to renegotiate its spectrum access each time when entering a new zone.

8.4 Closed-loop data base

It is assumed that there is only one closed-loop data base similar the primary data base:

- minimum needed set of information per S3D:
 - output power
 - bandwidth
 - centre frequency
 - location
 - time of last update
 - periodicity of update between DSAS and data base
 - included in the data base
 - provided by connected DSASs
- interface
- minimum refresh time (dynamic) / availability

For IRC the whole information is required to be exchanged.

Kind of LBT process:

- first read data base
- calculate solution
- second read of data base to check if another DSAS has occupied the targeted spectrum
- write spectrum data into data base
- assign spectrum to S3D

Annex A (informative): Bibliography

- WINNF TS-0112: "Requirements for Commercial Operation in the U.S. 3550-3700 MHz Citizens Broadband Radio Service Band".
- WINNF TS-1014: "Functional Requirements for the U.S. 6 GHz Band under the Control of an AFC System".

History

Version	Date	Status
V1.1.1	July 2024	Publication
V1.2.1	April 2026	Publication