



TECHNICAL SPECIFICATION

Publicly Available Specification (PAS); O-RAN Architecture Description (O-RAN.WG1.TS.OAD-R004 - v14.00)

CAUTION

The present document has been submitted to ETSI as a PAS produced by O-RAN Alliance and approved by the ETSI Technical Committee Mobile Standards Group (MSG).

ETSI had been assigned all the relevant copyrights related to the document O-RAN.WG1.TS.OAD-R004 - v14.00 on an "as is basis". Consequently, to the fullest extent permitted by law, ETSI disclaims all warranties whether express, implied, statutory or otherwise including but not limited to merchantability, non-infringement of any intellectual property rights of third parties. No warranty is given about the accuracy and the completeness of the content of the present document.

ReferenceRTS/MSG-001178

Keywordsarchitecture, O-RAN, PAS

ETSI

650 Route des Lucioles
F-06921 Sophia Antipolis Cedex - FRANCE

Tel.: +33 4 92 94 42 00 Fax: +33 4 93 65 47 16

Siret N° 348 623 562 00017 - APE 7112B
Association à but non lucratif enregistrée à la
Sous-Préfecture de Grasse (06) N° w061004871

Important notice

The present document can be downloaded from the
[ETSI Search & Browse Standards](#) application.

The present document may be made available in electronic versions and/or in print. The content of any electronic and/or print versions of the present document shall not be modified without the prior written authorization of ETSI. In case of any existing or perceived difference in contents between such versions and/or in print, the prevailing version of an ETSI deliverable is the one made publicly available in PDF format on [ETSI deliver](#) repository.

Users should be aware that the present document may be revised or have its status changed,
this information is available in the [Milestones listing](#).

If you find errors in the present document, please send your comments to
the relevant service listed under [Committee Support Staff](#).

If you find a security vulnerability in the present document, please report it through our
[Coordinated Vulnerability Disclosure \(CVD\)](#) program.

Notice of disclaimer & limitation of liability

The information provided in the present deliverable is directed solely to professionals who have the appropriate degree of experience to understand and interpret its content in accordance with generally accepted engineering or other professional standard and applicable regulations.

No recommendation as to products and services or vendors is made or should be implied.

No representation or warranty is made that this deliverable is technically accurate or sufficient or conforms to any law and/or governmental rule and/or regulation and further, no representation or warranty is made of merchantability or fitness for any particular purpose or against infringement of intellectual property rights.

In no event shall ETSI be held liable for loss of profits or any other incidental or consequential damages.

Any software contained in this deliverable is provided "AS IS" with no warranties, express or implied, including but not limited to, the warranties of merchantability, fitness for a particular purpose and non-infringement of intellectual property rights and ETSI shall not be held liable in any event for any damages whatsoever (including, without limitation, damages for loss of profits, business interruption, loss of information, or any other pecuniary loss) arising out of or related to the use of or inability to use the software.

Copyright Notification

No part may be reproduced or utilized in any form or by any means, electronic or mechanical, including photocopying and microfilm except as authorized by written permission of ETSI.

The content of the PDF version shall not be modified without the written authorization of ETSI.

The copyright and the foregoing restriction extend to reproduction in all media.

© ETSI 2026.
All rights reserved.

Contents

Intellectual Property Rights	5
Foreword.....	5
Modal verbs terminology.....	5
Introduction	6
1 Scope	7
2 References	7
2.1 Normative references	7
2.2 Informative references.....	9
3 Definition of terms, symbols and abbreviations.....	9
3.1 Terms.....	9
3.2 Symbols.....	11
3.3 Abbreviations	11
4 General O-RAN architecture principles	13
5 O-RAN Architecture	13
5.1 Overall architecture of O-RAN	13
5.2 O-RAN control loops	15
5.3 Description of O-RAN Functions.....	16
5.3.1 Service Management and Orchestration (SMO).....	16
5.3.1.1 SMO architecture principles.....	16
5.3.1.2 SMO Services (SMOSs)	17
5.3.1.2.1 Introduction to SMO Services	17
5.3.1.2.2 SMO in the O-RAN architecture.....	18
5.3.1.2.3 Non-RT RIC	18
5.3.1.2.4 SMO capabilities extensions	19
5.3.1.2.5 External exposure of SMO capabilities and data.....	19
5.3.2 Near-RT RIC	19
5.3.3 O-CU-CP	20
5.3.4 O-CU-UP.....	20
5.3.5 O-DU	20
5.3.6 O-RU	21
5.3.7 O-eNB.....	21
5.3.8 O-Cloud	22
5.4 Relevant interfaces in O-RAN architecture.....	22
5.4.1 Introduction to relevant interfaces in O-RAN architecture.....	22
5.4.2 A1 interface	23
5.4.3 O1 interface	23
5.4.4 O2 interface	23
5.4.5 E2 interface.....	23
5.4.6 O-Cloud Notification interface	23
5.4.7 Open Fronthaul interface	24
5.4.8 E1 interface.....	24
5.4.9 F1-c interface.....	24
5.4.10 F1-u interface.....	24
5.4.11 NG-c interface	24
5.4.12 NG-u interface	24
5.4.13 X2-c interface	24
5.4.14 X2-u interface	24
5.4.15 Xn-c interface	24
5.4.16 Xn-u interface	25
5.4.17 Uu interface	25
5.4.18 CTI (Cooperative Transport Interface).....	25
5.4.19 Y1 interface	25
5.4.20 R1 interface.....	25

5.4.21	Near-RT RIC APIs.....	25
5.4.22	D2 interface	25
5.5	UE associated identifiers used in O-RAN	25
5.6	O-RAN security architecture.....	26
6	O-RAN Information Model (IM) principles.....	27
Annex A (informative): Implementation options of O-RAN functions and network elements		28
A.1	Shared cell.....	28
A.2	FHGW function.....	29
A.3	Near-RT RIC	30
A.4	Near-RT RIC, O-CU-CP, O-CU-UP, O-DU, and O-RU	31
A.5	Cooperative transport	35
A.6	Inter O-DU Carrier Aggregation (CA).....	35
Annex B (informative): Change history		36
History		38

Intellectual Property Rights

Essential patents

IPRs essential or potentially essential to normative deliverables may have been declared to ETSI. The declarations pertaining to these essential IPRs, if any, are publicly available for **ETSI members and non-members**, and can be found in ETSI SR 000 314: "*Intellectual Property Rights (IPRs); Essential, or potentially Essential, IPRs notified to ETSI in respect of ETSI standards*", which is available from the ETSI Secretariat. Latest updates are available on the [ETSI IPR online database](#).

Pursuant to the ETSI Directives including the ETSI IPR Policy, no investigation regarding the essentiality of IPRs, including IPR searches, has been carried out by ETSI. No guarantee can be given as to the existence of other IPRs not referenced in ETSI SR 000 314 (or the updates on the ETSI Web server) which are, or may be, or may become, essential to the present document.

Trademarks

The present document may include trademarks and/or tradenames which are asserted and/or registered by their owners. ETSI claims no ownership of these except for any which are indicated as being the property of ETSI, and conveys no right to use or reproduce any trademark and/or tradename. Mention of those trademarks in the present document does not constitute an endorsement by ETSI of products, services or organizations associated with those trademarks.

DECT™, **PLUGTESTS™**, **UMTS™** and the ETSI logo are trademarks of ETSI registered for the benefit of its Members. **3GPP™**, **LTE™** and **5G™** logo are trademarks of ETSI registered for the benefit of its Members and of the 3GPP Organizational Partners. **oneM2M™** logo is a trademark of ETSI registered for the benefit of its Members and of the oneM2M Partners. **GSM®** and the GSM logo are trademarks registered and owned by the GSM Association.

Foreword

This Technical Specification (TS) has been produced by O-RAN Alliance and approved by ETSI Technical Committee Mobile Standards Group (MSG).

The content of the present document is subject to continuing work within O-RAN and may change following formal O-RAN approval. Should the O-RAN Alliance modify the contents of the present document, it will be re-released by O-RAN with an identifying change of version date and an increase in version number as follows:

version xx.yy.zz

where:

- xx: the first digit-group is incremented for all changes of substance, i.e. technical enhancements, corrections, updates, etc. (the initial approved document will have xx=01). Always 2 digits with leading zero if needed.
- yy: the second digit-group is incremented when editorial only changes have been incorporated in the document. Always 2 digits with leading zero if needed.
- zz: the third digit-group included only in working versions of the document indicating incremental changes during the editing process. External versions never include the third digit-group. Always 2 digits with leading zero if needed.

Modal verbs terminology

In the present document "**shall**", "**shall not**", "**should**", "**should not**", "**may**", "**need not**", "**will**", "**will not**", "**can**" and "**cannot**" are to be interpreted as described in clause 3.2 of the [ETSI Drafting Rules](#) (Verbal forms for the expression of provisions).

"**must**" and "**must not**" are **NOT** allowed in ETSI deliverables except when used in direct citation.

Introduction

O-RAN activities are guided by the following objectives as specified in O-RAN Whitepaper [i.5]:

- Leading the industry towards open, interoperable interfaces, RAN virtualization, and big data and AI enabled RAN intelligence.
- Maximizing the use of common-off-the-shelf hardware and merchant silicon and minimizing proprietary hardware.
- Specifying APIs and interfaces, driving standards to adopt them as appropriate, and exploring open source where appropriate.
- The O-RAN Architecture identifies the key functions and interfaces adopted in O-RAN.

1 Scope

The present document:

- specifies the overall architecture of O-RAN;
- describes the O-RAN architecture elements and relevant interfaces that connect them.

2 References

2.1 Normative references

References are either specific (identified by date of publication and/or edition number or version number) or non-specific. For specific references, only the cited version applies. For non-specific references, the latest version of the referenced document (including any amendments) applies.

Referenced documents which are not found to be publicly available in the expected location might be found in the [ETSI docbox](#).

NOTE: While any hyperlinks included in this clause were valid at the time of publication, ETSI cannot guarantee their long-term validity.

The following referenced documents are necessary for the application of the present document.

- [1] [ETSI TS 123 501](#): "5G; System architecture for the 5G System (5GS) (3GPP TS 23.501)".
- [2] [ETSI TS 128 622](#): "Universal Mobile Telecommunications System (UMTS); LTE; 5G; Telecommunication management; Generic Network Resource Model (NRM) Integration Reference Point (IRP); Information Service (IS) (3GPP TS 28.622)".
- [3] [ETSI TS 132 101](#): "Digital cellular telecommunications system (Phase 2+) (GSM); Universal Mobile Telecommunications System (UMTS); LTE; Telecommunication management; Principles and high level requirements (3GPP TS 32.101)".
- [4] [ETSI TS 136 401](#): "LTE; Evolved Universal Terrestrial Radio Access Network (E-UTRAN); Architecture description (3GPP TS 36.401)".
- [5] [ETSI TS 136 413](#): "LTE; Evolved Universal Terrestrial Radio Access Network (E-UTRAN); S1 Application Protocol (S1AP) (3GPP TS 36.413 version 19.1.0 Release 19)".
- [6] [ETSI TS 136 420](#): "LTE; Evolved Universal Terrestrial Radio Access Network (E-UTRAN); X2 general aspects and principles (3GPP TS 36.420)".
- [7] [ETSI TS 136 423](#): "LTE; Evolved Universal Terrestrial Radio Access Network (E-UTRAN); X2 Application Protocol (X2AP) (3GPP TS 36.423)".
- [8] [ETSI TS 138 300](#): "5G; NR; NR and NG-RAN Overall description; Stage-2 (3GPP TS 38.300)".
- [9] [ETSI TS 138 331](#): "5G; NR; Radio Resource Control (RRC); Protocol specification (3GPP TS 38.331)".
- [10] [ETSI TS 138 401](#): "5G; NG-RAN; Architecture description (3GPP TS 38.401)".
- [11] [ETSI TS 138 413](#): "5G; NG-RAN; NG Application Protocol (NGAP) (3GPP TS 38.413)".
- [12] [ETSI TS 138 420](#): "5G; NG-RAN; Xn general aspects and principles (3GPP TS 38.420)".
- [13] [ETSI TS 138 423](#): "5G; NG-RAN; Xn Application Protocol (XnAP) (3GPP TS 38.423)".
- [14] [ETSI TS 138 460](#): "5G; NG-RAN; E1 general aspects and principles (3GPP TS 38.460)".
- [15] [ETSI TS 138 463](#): "5G; NG-RAN; E1 Application Protocol (E1AP) (3GPP TS 38.463)".

- [16] [ETSI TS 138 470](#): "5G; NG-RAN; F1 general aspects and principles (3GPP TS 38.470)".
- [17] [ETSI TS 138 473](#): "5G; NG-RAN; F1 Application Protocol (F1AP) (3GPP TS 38.473)".
- [18] O-RAN.WG2.TS.A1GAP-R004: "A1 interface: General Aspects and Principles" ("A1GAP").
- [19] O-RAN.WG4.TS.CUS.0-R004: "Control, User and Synchronization Plane Specification" ("Open FH CUS-Plane").
- [20] O-RAN.WG4.CTI-TCP.0-R003: "Cooperative Transport Interface Transport Control Plane Specification" ("CTI Control").
- [21] [O-RAN.WG4.CTI-TMP.0-R003](#): "Cooperative Transport Interface Transport Management Procedures Specification" ("CTI Management").
- [22] O-RAN.WG3.TS.E2GAP-R004: "E2 General Aspects and Principles (E2GAP)".
- [23] O-RAN.WG7.IPC-HRD-Opt8.0: "Hardware Reference Design Specification for Indoor Picocell (FR1) with Split Architecture Option 8".
- [24] O-RAN.WG4.TS.MP.0-R004: "Management Plane Specification" ("Open FH M-Plane").
- [25] ORAN-WG3.E2SM-NI: "Near-Real-time RAN Intelligent Controller E2 Service Model (E2SM), RAN Function Network Interface (NI)".
- [26] O-RAN.WG3.TS.RICARCH-R004: "Near-RT RIC Architecture".
- [27] O-RAN.WG2.TS.Non-RT-RIC-ARCH-R004: "Non-RT RIC: Architecture".
- [28] O-RAN.WG6.O-Cloud Notification API: "O-Cloud Notification API Specification for Event Consumers".
- [29] O-RAN.WG6.AAL-GANP-R004: "Acceleration Abstraction Layer General Aspects and Principles" ("AALGAP").
- [30] O-RAN.WG10.TS.Information Model and Data Models.0-R004: "Information Model and Data Models Specification".
- [31] O-RAN.WG1.O1-Interface.0: "Operations and Maintenance Interface" ("OAM Interface").
- [32] O-RAN.WG11.TS.STS-R004: "O-RAN Security Test Specifications".
- [33] O-RAN.WG6.TS.O2-GA&P-R004: "O2 Interface General Aspects and Principles" ("O2GAP").
- [34] O-RAN.WG10.TS.OAM-Architecture-R004: "Operations and Maintenance Architecture" ("OAM Architecture").
- [35] O-RAN.WG2.TS.R1GAP-R004: "R1 Interface: General Aspects and Principles" ("R1GAP").
- [36] O-RAN.WG11.TS.SecProtSpec.0-R004: "Security Protocols Specifications".
- [37] O-RAN.WG11.TS.SRCS.0-R004: "Security Requirements and Controls Specifications".
- [38] O-RAN.WG1.TS.Use-Cases-Detailed-Specification-R004: "Use Cases Detailed Specification".
- [39] O-RAN.WG3.Y1GAP-R004: "Y1 interface: General Aspects and Principles" ("Y1GAP").
- [40] O-RAN.WG5.TS.D2GAP.0-R004: "D2 Interface: General Aspects and Principles" ("D2GAP").
- [41] [ETSI TS 137 340](#): "Universal Mobile Telecommunications System (UMTS); LTE; 5G; Evolved Universal Terrestrial Radio Access (E-UTRA) and NR; Multi-connectivity; Overall Description; Stage-2 (3GPP TS 37.340)".

2.2 Informative references

References are either specific (identified by date of publication and/or edition number or version number) or non-specific. For specific references, only the cited version applies. For non-specific references, the latest version of the referenced document (including any amendments) applies.

NOTE: While any hyperlinks included in this clause were valid at the time of publication, ETSI cannot guarantee their long-term validity.

The following referenced documents may be useful in implementing an ETSI deliverable or add to the reader's understanding, but are not required for conformance to the present document.

- [i.1] [ETSI TR 121 905](#): "Digital cellular telecommunications system (Phase 2+) (GSM); Universal Mobile Telecommunications System (UMTS); LTE; 5G; Vocabulary for 3GPP Specifications (3GPP TR 21.905)".
- [i.2] 3GPP TR 38.801: "Study on new radio access technology: Radio access architecture and interfaces (Release 14)".
- [i.3] O-RAN.WG6.CADS: "Cloud Architecture and Deployment Scenarios for O-RAN Virtualized RAN".
- [i.4] O-RAN.WG11.TR.Threat-Modeling.0-R004: "Security Threat Modeling and Risk Assessment".
- [i.5] O-RAN White Paper: "O-RAN: Towards an Open and Smart RAN", October 2018 ("O-RAN Whitepaper").
- [i.6] [NIST SP 800-207](#): "Zero-Trust Architecture", U.S. NIST, August 2020, Rose S., Borchert O., Mitchell S. and Connelly, S.
- [i.7] US DHS CISA: "Zero Trust Maturity Model", April 2023.

3 Definition of terms, symbols and abbreviations

3.1 Terms

For the purposes of the present document, the terms given in ETSI TR 121 905 [i.1] and the following apply:

E2 Node: logical node terminating E2 interface

Managed Element: The definition of a Managed Element (ME) is given in ETSI TS 128 622 [2], clause 4.3.3.

Managed Function: The definition of a Managed Function (MF) is given in ETSI TS 128 622 [2], clause 4.3.4.

Near-Real-Time RAN Intelligent Controller: O-RAN Network Function (NF) comprised of the Near-RT RIC platform and Near-RT RIC Applications (xApps)

Near-RT RIC APIs: set of service-based interfaces that can be produced and consumed by the Near-RT RIC Platform and xApps

NOTE: Refer to Near-RT RIC Architecture [26] for more information.

Near-RT RIC platform: platform supporting A1, E2, Y1 and O1 interfaces and providing a set of services via Near-RT RIC APIs needed for xApp functionality

Non-Real-Time RAN Intelligent Controller: functionality within SMO comprised of the Non-RT RIC Framework and the Non-RT RIC Applications (rApps) that manages the content carried across the A1 interface

NOTE: Refer to Non-RT RIC: Architecture [27] for more information.

Non-RT RIC Framework: functionality within the Non-RT RIC that logically terminates the A1 interface and provides support for rApps, including the R1 services through the R1 interface

NMS: Network Management System for the O-RU as specified in Open FH M-Plane [24] to support legacy Open Fronthaul M-Plane deployments

NOTE: Applicable to Open FH M-Plane deployment prior to version 5 of the Open FH M-Plane [24].

O-Cloud: cloud platform that provides O-RAN standardized interfaces, hosting O-RAN defined software components

NOTE: Refer to Cloud Architecture and Deployment Scenarios for O-RAN Virtualized RAN [i.3] for more information.

O-eNB: O-RAN eNB as specified in ETSI TS 136 401 [4] or O-RAN ng-eNB as specified in ETSI TS 138 300 [8]

NOTE: Refer to clause 5.3.7 for more information.

O-RAN Central Unit – Control Plane: logical node hosting the RRC and the control plane part of the PDCP protocol

NOTE: Refer to clause 5.3.3 for more information.

O-RAN Central Unit – User Plane: logical node hosting the user plane part of the PDCP protocol and the SDAP protocol

NOTE: Refer to clause 5.3.4 for more information.

O-RAN Distributed Unit: logical node hosting RLC/MAC/High-PHY layers based on a lower layer functional split

NOTE: Refer to clause 5.3.5 for more information.

O-RAN Network Function: network function with O-RAN defined behaviours and interfaces, which can also inherit and/or extend defined behaviours and interfaces of a 3GPP Network Function

NOTE: 3GPP Network Function is defined in ETSI TS 123 501 [1].

O-RAN node: same as an O-RAN NF

O-RAN Radio Unit: logical node hosting Low-PHY layer and RF processing based on a lower layer functional split

NOTE: This is similar to 3GPP's "TRP" or "RRH" but more specific in including the Low-PHY layer (FFT/iFFT, PRACH extraction). Refer to clause 5.3.6 for more information.

O1: interface used by the SMO framework, as specified in clause 5.3.1, for operation and management of O-RAN NFs as specified in OAM Interface [31]

O2: interface between SMO framework as specified in clause 5.3.1 and the O-Cloud

NOTE: Refer to O2GAP [33] for more information.

Open Fronthaul M-Plane: management interface controlling the O-RU, generally driven from the O-DU but in the case of the hybrid topology also driven from the SMO

NOTE: Refer to Open FH M-Plane [24] for more details.

PCell O-DU: O-DU where SpCell (Special Cell as defined in ETSI TS 137 340 [41]) is configured for a particular UE for supporting inter O-DU carrier aggregation

rApp: modular application that consumes and/or produces non real time management and automation services

R1 Interface: service-based interface between the rApps and the Non-RT RIC Framework via which R1 services can be produced and consumed

NOTE: Refer to R1GAP [35] for more information.

SCell O-DU: O-DU where SCell (Secondary Cell as defined in ETSI TS 137 340 [41]) is configured for a particular UE for supporting inter O-DU carrier aggregation

SMO: Service Management and Orchestration framework

NOTE: Refer to clause 5.3.1 for more details.

SMO External Interface: interface between the SMO and an SMO External System

SMO External System: data source outside the O-RAN domain that provides data to the SMO

NOTE: External consumers of SMO data are not addressed in the present document.

SMO Functions (SMOFs): internal SMO entities which provide one or more SMO Services

NOTE: An SMO Function exposes standardized interfaces which enable interoperability between SMO Functions.

SMO Service (SMOS): standardized cohesive set of management, orchestration and automation capabilities offered by an SMO Function

xApp: application consuming and/or producing Near-RT RIC services via the Near-RT RIC API to provide value added control of, or guidance to the E2 Nodes

Y1: interface over which RAN analytics services are exposed by the Near-RT RIC to be consumed by Y1 consumers

Y1 consumers: role played by entities within or outside of the PLMN trust domain that consumes the Y1 services produced by the Near-RT RIC

3.2 Symbols

Void.

3.3 Abbreviations

For the purposes of the present document, the abbreviations given in ETSI TR 121 905 [i.1] and the following apply:

3GPP	3 rd Generation Partnership Project
4G	4 th Generation of mobile communications
5G	5 th Generation of mobile communications
5GC	5G Core
AAL	Accelerator Abstraction Layer
AI	Artificial Intelligence
AMF	Access and Mobility Functions
API	Application Programming Interface
CA	Carrier Aggregation
CMTS	Cable Modem Termination System
CP	Control Plane
CSP	Communications Service Provider
CTI	Cooperative Transport Interface
CUS	Control User Synchronization
DC	Dual Connectivity
DM	Data Model
DME	Data Management and Exposure
DOCSIS	Data Over Cable Service Interface Specification
DTLS	Datagram Transport Layer Security
eNB	evolved Node B
EN-DC	E-UTRAN New Radio - Dual Connectivity
EPC	Evolved Packet Core
E-UTRAN	Evolved Universal Terrestrial Radio Access Network
FCAPS	Fault, Configuration, Accounting, Performance, Security
FFT	Fast Fourier Transform
FHGW	Fronthaul Gateway
FHM	Fronthaul Multiplexer
gNB	next generation Node B
gNB-CU	gNB Central Unit
gNB-DU	gNB Distributed Unit
GUAMI	Globally Unique AMF Identifier
GUMMEI	Globally Unique MME Identifier

HARQ	Hybrid Automatic Repeat Request
ID	Identifier
iFFT	inverse Fast Fourier Transform
IM	Information Model
LLS	Lower Layer Split
LTE	Long Term Evolution
MAC	Media Access Control
ME	Managed Element
MeNB	Master eNB
MF	Managed Function
ML	Machine Learning
MME	Mobility Management Entity
Near-RT RIC	Near-Real-Time RAN Intelligent Controller
NETCONF	Network Configuration Protocol
NF	Network Function
NG	Next Generation
NGAP	Next Generation Application Protocol
NG-RAN	Next Generation RAN
NIST	National Institute of Standards and Technology
NMS	Network Management System
Non-RT RIC	Non-Real-Time RAN Intelligent Controller
NR	5G New Radio
OAM	Operations, Administration and Maintenance
O-Cloud	O-RAN Cloud
O-CU-CP	O-RAN Central Unit – Control Plane.
O-CU-UP	O-RAN Central Unit – User Plane
O-DU	O-RAN Distributed Unit
O-eNB	O-RAN eNB
OLT	Optical Line Terminal
ONU	Optical Network Unit
Open FH	Open Fronthaul
O-RU	O-RAN Radio Unit
PDCP	Packet Data Convergence Protocol
PHY	Physical layer
PNF	Physical Network Function
PON	Passive Optical Network
PRACH	Physical Random Access Channel
PTP	Precision Time Protocol
RAN	Radio Access Network
rApp	Non-RT RIC Application
RF	Radio Frequency
RIC	RAN Intelligent Controller
RLC	Radio Link Control
RRC	Radio Resource Control
RRH	Remote Radio Head
RRU	Remote Radio Unit
RT	Real Time
RU	Radio Unit
SBA	Service Based Architecture
SBOM	Software Bill of Materials
SDAP	Service Data Adaptation Protocol
SME	Service Management and Exposure
SMO	Service Management and Orchestration
SMOF	Service Management and Orchestration Function
SMOS	Service Management and Orchestration Service
SRB	Signalling Radio Bearer
SSHv2	Secure Shell 2.0
TLS	Transport Layer Security
TN	Transport Node
TR	Technical Report
TRP	Transmission and Reception Point
TS	Technical Specification

TU	Transport Unit
UE	User Equipment
UL	Up Link
UP	User Plane
UPF	User Plane Function
WG	Working Group
X2AP	X2 Application Protocol
xApp	Near-RT RIC Application
XnAP	Xn Application Protocol
ZTA	Zero Trust Architecture

4 General O-RAN architecture principles

This clause contains the general O-RAN architecture principles as described below:

- The O-RAN architecture, interface specifications, and terminology shall be consistent with 3GPP architecture, interface specifications, and terminology with additions to accommodate O-RAN specific features.
- The present document represents the O-RAN architecture at the time of its publication and may evolve as deemed appropriate by the O-RAN ALLIANCE.
- The O-RAN architecture includes a logical representation of a Radio Access Network (RAN) which extends the 3GPP specified RAN and consists of logical NFs or logical nodes (as per ETSI TS 138 300 [8] and ETSI TS 123 501 [1]).

NOTE: Therefore, the terms O-RAN NFs as well as O-RAN nodes are used interchangeably to refer to some of the logical O-RAN entities, according to the context used in that particular statement. In any case, they always refer to a logical entity and not to a physical or cloudified instantiation of an O-RAN NF or an O-RAN node.

5 O-RAN Architecture

5.1 Overall architecture of O-RAN

Figure 5.1-1 below provides a high-level view of the O-RAN architecture. It shows that the interfaces - A1, O1, Open Fronthaul M-plane and O2 - connecting SMO (Service Management and Orchestration) framework to O-RAN Network Functions and to O-Cloud. As depicted in this figure, the O-Cloud includes the O-Cloud Notification interface as specified in O-Cloud Notification API Specification for Event Consumers [28] is available for the relevant O-RAN Network Functions (i.e. Near-RT RIC, O-CU-CP, O-CU-UP and O-DU) to receive O-Cloud related notifications.

Figure 5.1-1 below also illustrates that the O-RAN Network Functions can be hosted on the O-Cloud or on customized hardware.

All O-RAN NFs, except O-RU, are managed via the O1 interface to an authorized SMO framework.

The O1 interface exposes management services for the O-RAN NFs that are managed individually or together, as specified in OAM Architecture [34].

The Open Fronthaul M-plane interface, between SMO and O-RU, supports the O-RU management in hybrid mode, as specified in Open FH M-Plane [24].

O-RAN NFs instantiated on the O-Cloud may utilize the APIs exposed by the Accelerator Abstraction Layer (AAL) defined in AALGAP [29].

The Near-RT RIC O-RAN NF in figure below provides RAN analytics information services via the Y1 service interface as specified in Y1GAP [39]. These services can be consumed by Y1 consumers after mutual authentication and authorization by subscribing to or requesting the RAN analytics information via the Y1 service interface. Y1 consumers role can be played by entities which are within an PLMN trusted domain. Y1 consumers outside the PLMN trusted domain may use Y1 services in a secure manner via an exposure function, e.g. as in ETSI TS 123 501 [1], clause 5.20. The framework for mutual authentication and authorization between Y1 consumers and the Near-RT RIC is not supported in the present document.

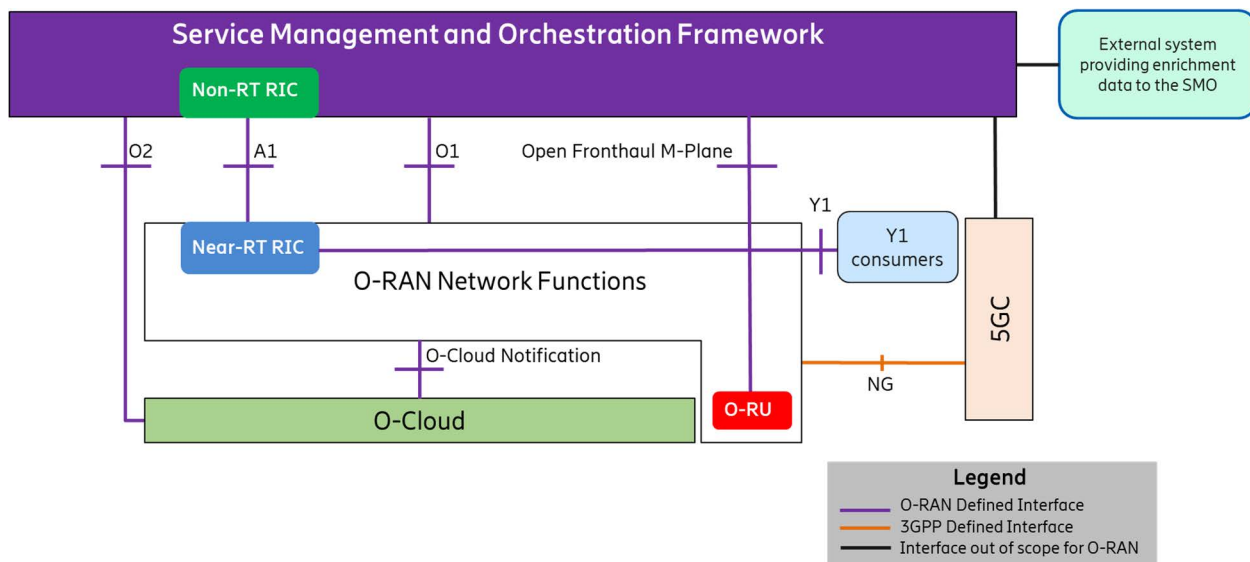

Figure 5.1-1: High Level Architecture of O-RAN

Within the logical architecture of O-RAN, as shown in Figure 5.1-2 below, the radio side includes Near-RT RIC, O-CU-CP, O-CU-UP, O-DU, and O-RU O-RAN NFs. The E2 interface connects O-eNB to Near-RT RIC. Although not shown in this figure, the O-eNB does support O-DU and O-RU O-RAN NFs with an Open Fronthaul interface between them. The Near-RT RIC, in figure 5.1-2 below, supports the Y1 service interface towards Y1 consumers. Y1 consumers, unlike the other network elements shown in this figure, does not denote a logical O-RAN function.

As stated earlier, the management side includes SMO Framework containing a Non-RT-RIC function. The O-Cloud, on the other hand, is a cloud computing platform comprising a collection of physical infrastructure nodes that meet O-RAN requirements to host the relevant O-RAN NFs (such as Near-RT RIC, O-CU-CP, O-CU-UP, and O-DU, etc.), the supporting software components (such as Operating System, Virtual Machine Monitor, Container Runtime, etc.) and the appropriate management and orchestration functions. The virtualization of O-RU is not supported in the present document.

As shown in this figure, the O-RU provides the Open Fronthaul M-Plane interface to authorized O-DU in hierarchical mode, or to authorized O-DU and SMO in hybrid mode as specified in Open FH M-Plane [24] and OAM Architecture [34].

NOTE: The LLS (O-DU to O-RU interface) specified in clauses 5.3.5 and 5.3.6 (Split Option 7-2x) is the Open Fronthaul interface described in the Open FH CUS-Plane [19]. Other LLS options specified in 3GPP TR 38.801 [i.2] may be considered for reference designs when the relevant interfaces are described in specifications created by related open industry initiatives (e.g. the Small Cell Forum for Split Option 6) or in O-RAN white-box hardware specifications (e.g. Split Option 8).

As shown in Figure 5.1-2, O-DU provides D2 interface to connect with peer O-DU for supporting inter O-DU carrier aggregation. The D2 interface includes D2-u and D2-c services.

- Near-RT (Near-Real Time) control loops
- RT (Real Time) control loops

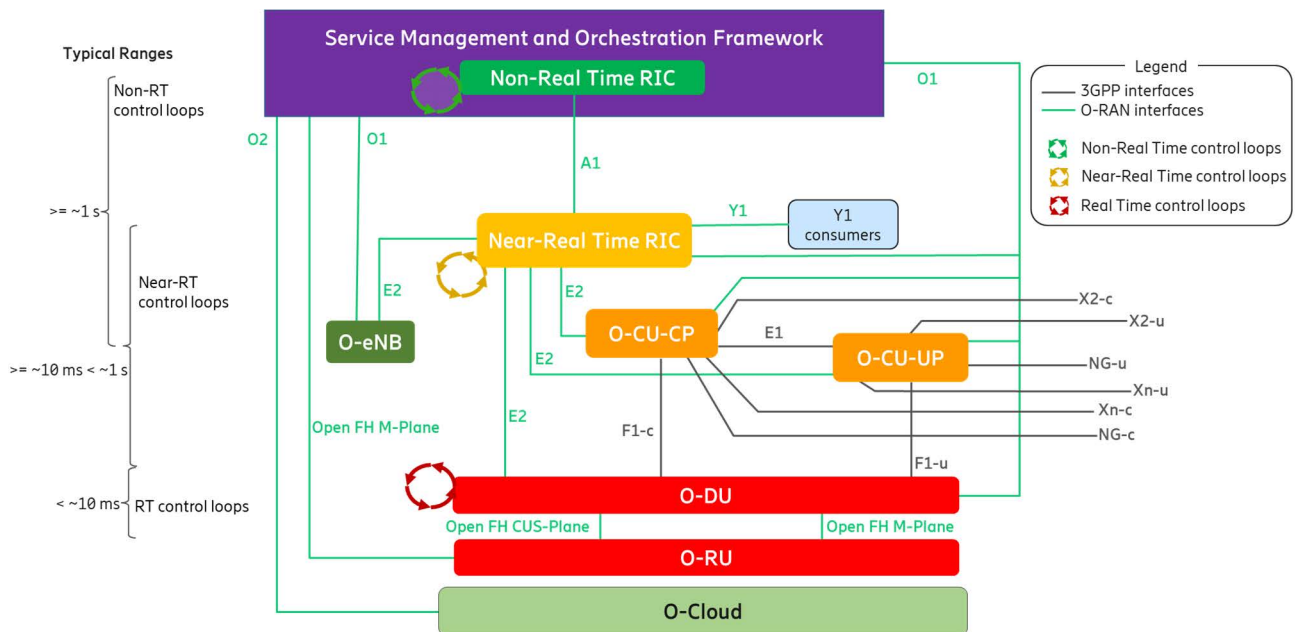

Figure 5.2-1: O-RAN Control Loops

As shown in Figure 5.2-1 above, the control loops are defined based on the controlling entity and the architecture shows the other logical entities with which the control loop host interacts.

Control loops exist at various levels and run simultaneously. Depending on the use case, they may or may not interact with each other. The use cases for the Non-RT and Near-RT control loops and the interaction between the RICs for these use cases are fully defined by O-RAN Use Cases Detailed Specification [38]. The Use Cases Detailed Specification [38] also defines relevant interaction for the O-CU-CP and O-DU control loops, responsible for call control and mobility, radio scheduling, HARQ, beamforming, etc. along with slower mechanisms involving SMO management interfaces.

The timing of these control loops is use case dependent. Typical execution time for use cases involving the Non-RT control loops is 1 second or more; Near-RT control loops are in the order of 10 milliseconds or more; control loops in the E2 Nodes can operate below 10 milliseconds (e.g. O-DU radio scheduling).

For any specific use case, however, a stable solution would require the loop time in the Non-RT RIC and/or SMO management plane processes to be significantly longer than the loop time for the same use case in the control entities stated above.

5.3 Description of O-RAN Functions

5.3.1 Service Management and Orchestration (SMO)

5.3.1.1 SMO architecture principles

Service Based Architecture (SBA) introduces the roles of service producer and service consumer together with standardized service-based interfaces. These standardized service-based interfaces enable interoperability within the SMO. SBA is not concerned with the implementation, but it defines logical functions in their service producer and consumer roles. When properly applied the SBA approach can enable the following:

- Validates produced services with consumer use cases.
- Identifies service operations with their information model defining semantic behaviour.

- Specifies the API and a data model for a syntactic interface.
- Identifies common services that can be produced by a single producer such as those that are commonly used by multiple internal consumers (e.g. authentication, authorization, service registration and discovery, data management, etc.).

5.3.1.2 SMO Services (SMOSs)

5.3.1.2.1 Introduction to SMO Services

In the O-RAN architecture, SMO is responsible for RAN domain management. The SMO description in this architecture document is focused on the SMO services that support the RAN. Following the SBA principles above, the SMO Services produced by the SMO are defined. A SMOF implementation can produce and/or consume any combinations of one or more SMOSs, provided that the SMOF complies with the O-RAN specifications of the interfaces exposing the SMOSs.

The Non-RT RIC SMOF example depicted in Figure 5.3.1.2.1-1 below shows support for rApps and for A1 related SMOSs. Otherwise, the definition of SMOFs is in general not in scope of the O-RAN specifications, as the interoperable functional behaviour of SMOFs is specified via the SMOS Producer/Consumer roles.

The SMO Services produced by the SMO are:

- RAN NF OAM SMO Service specified in ETSI TS 132 101 [3], including capabilities such as:
 - RAN NF Performance Assurance Management (NFPM)
 - RAN NF Fault Supervision Management (NFFM)
 - RAN NF Provisioning Management (NFCM)
 - Others, e.g. Tracing, Logging, etc.
- Network Functions Orchestration (NFO) SMOS.
- Federated O-Cloud Orchestration and Management (FOCOM) SMOS.
- Service Management and Exposure (SME) SMOS.
- Data Management and Exposure (DME) SMOS.
- Topology Exposure and Inventory Management (TE&IV) SMOS.
- RAN Analytics SMOS.
- Service & Subnet Slice Orchestration SMOS.
- Service & Subnet Slice Assurance SMOS.
- AI/ML workflow (AIMLWF) SMOS.
- rApp Management SMOS.
- A1 related SMOSs.
- Software package onboarding SMOS.
- Policy Management and Information (PMI).

SME SMOS supports the exposure of other SMOSs, to both internal and external SMOS consumers.

DME SMOS supports the exposure of data produced by SMOS Producers, to both internal and external SMOS consumers.

The SMOSs described in the present document are represented in a service-based architecture in Figure 5.3.1.2.1-1 below.

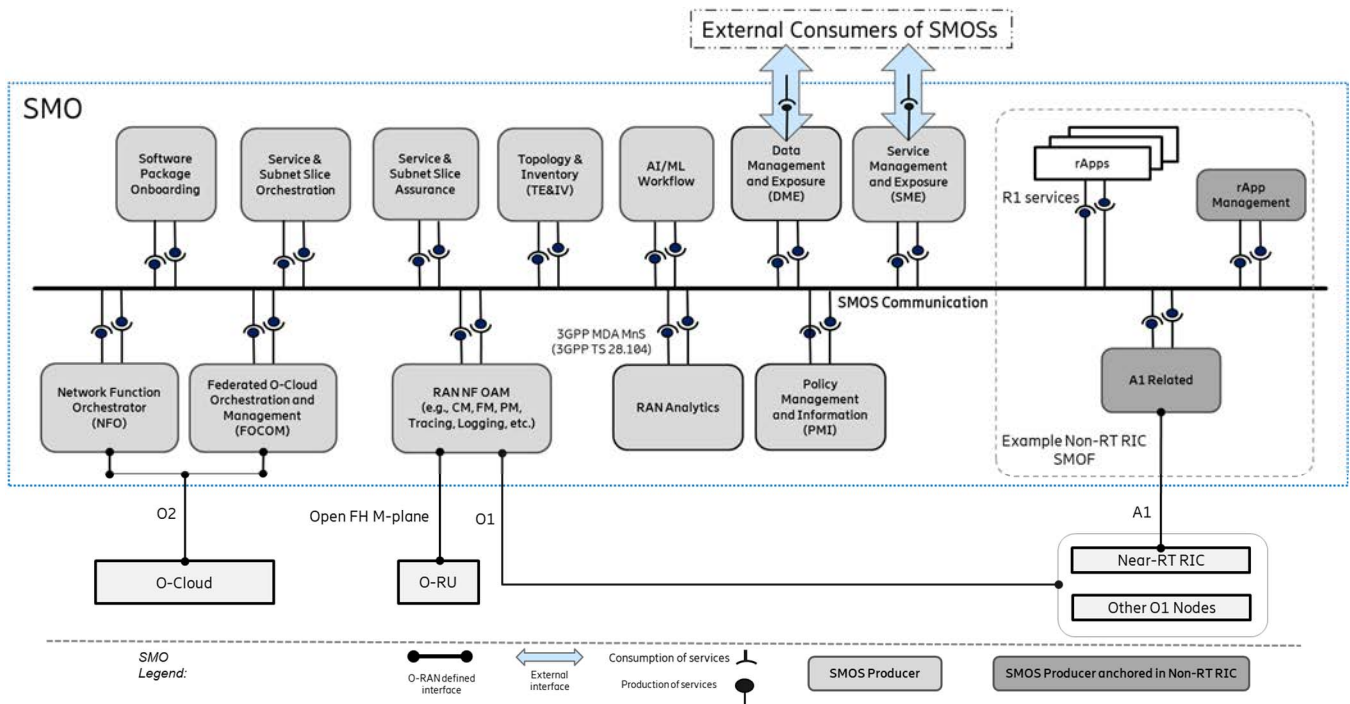

Figure 5.3.1.2.1-1: SMOs in the SMO SBA representation

The SMOS Communication, shown in Figure 5.3.1.2.1-1, represents the logical support for communication between any SMOS Producer, SMOS Consumer, and rApps. Examples of SMOS Communication implementation include, but are not limited to, service mesh, API gateway, direct communication, and message bus. SMOS consumers and producers rely on the capabilities provided by SME for purposes such as service discovery and on the capabilities provided by DME for purposes such as data exposure.

5.3.1.2.2 SMO in the O-RAN architecture

All the SMO Service producers represented in Figure 5.3.1.2.1-1 can also be SMOS consumers.

The SMO consumes services offered by other O-RAN architecture elements through four key southbound interfaces:

- A1 Interface between the Non-RT RIC in the SMO and the Near-RT RIC for RAN Optimization.
- O1 Interface provides SMO FCAPS support either directly or indirectly between the SMO and the O-RAN Network Functions.
- In the hierarchical model, SMO FCAPS support information over O1 to the O-DU which uses the Open FH M-Plane interface to manage the O-RU.
- In the hybrid model, SMO provides FCAPS support information over Open FH M-Plane interface between the SMO and the O-RU and over O1 to the O-DU which uses the Open FH M-Plane interface to manage the O-RU.
- O2 Interface between the SMO and the O-Cloud to provide O-Cloud resource management and workload management.

5.3.1.2.3 Non-RT RIC

Non-RT RIC is the functionality internal to the SMO that supports intelligent RAN optimization by:

- enabling an A1-related SMOS to provide policy-based guidance over the A1 interface;
- enabling an A1-related SMOS to provide enrichment information over the A1 interface;
- enabling an A1-related SMOS to provide ML model management over the A1 interface;

- enabling RAN optimization actions through RAN NF OAM SMOS over O1 and Open FH M-Plane interfaces, and NFO and FOCOM SMOSs over O2 interface.

The rApps can be producers and/or consumers of R1 services, as shown in Figure 5.3.1.2.1-1. For more information on R1 services and the R1 interface refer to Non-RT RIC Architecture [27].

Non-RT RIC supports intelligent RAN optimization control loops through rApps with intervals greater than 1 second.

5.3.1.2.4 SMO capabilities extensions

As a flexible extension mechanism, the SMO allows delivery of aspects of RAN management and orchestration functionality via rApps.

5.3.1.2.5 External exposure of SMO capabilities and data

The exposure of SMO capabilities and data to external SMO consumers is done via SME and DME respectively, as represented in an SBA approach depicted in Figure 5.3.1.2.5-1.

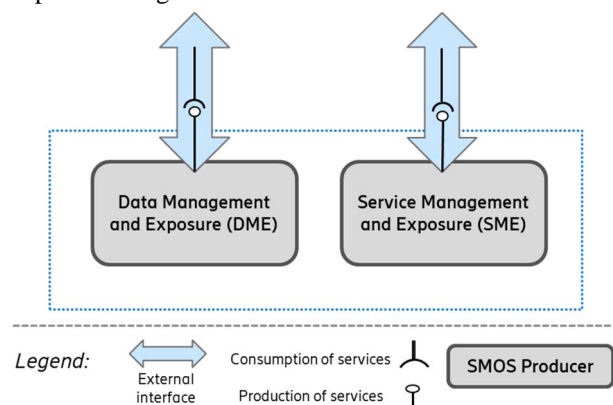

Figure 5.3.1.2.5-1: SMO external terminations

5.3.2 Near-RT RIC

Near-RT RIC is an O-RAN NF that enables near real-time control and optimization of services and resources of E2 Nodes via fine-grained data collection and actions over the E2 interface with control loops in the order of 10 ms - 1 s. The Near-RT RIC hosts one or more xApps that use E2 interface to collect near real-time information (e.g. on a UE basis or a Cell basis) and provide value added services. The Near-RT RIC control over the E2 Nodes is steered via the policies and the enrichment data provided via A1 from the Non-RT RIC. Based on the available data, the Near-RT RIC generates the RAN analytics information and exposes it via Y1 interface.

The functional enhancement provided by the Near-RT RIC and the E2 Node is subject to the capability of the E2 Node exposed over the E2 interface by means of the E2SM [25], in order to support the use cases described in Use Cases Detailed Specification [38]. The E2 service model describes the functions in the E2 Node which may be controlled by the Near-RT RIC and the related procedures. For a function exposed in the E2SM [25], the Near-RT RIC may e.g. monitor, override, or control via policies the behavior of E2 Node.

In the event of a Near-RT RIC failure, the E2 Node shall be able to provide services but there may be an impact to certain optimization capabilities that are provided by the Near-RT RIC.

The Near-RT RIC is composed of a Near-RT RIC platform and one or more xApps as specified in Near-RT RIC Architecture [26] and their capabilities are exposed as services. Both the Near-RT RIC platform and an xApp can be a service producer and/or a service consumer, and these services can be accessed via the set of Near-RT RIC APIs as illustrated in Figure 5.3.2-1.

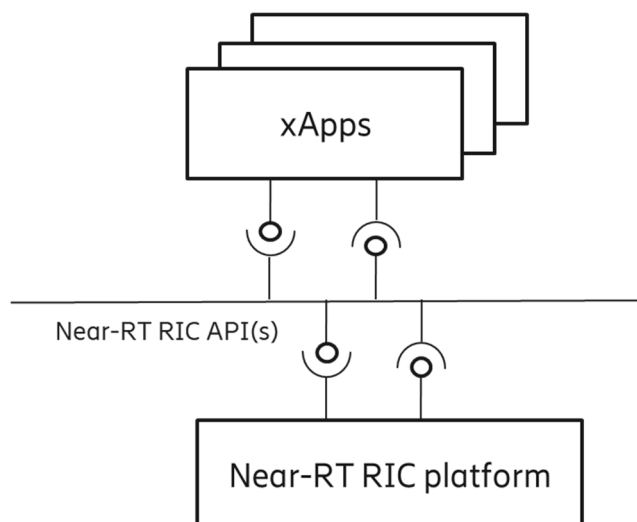

Figure 5.3.2-1: Service-based representation of Near-RT RIC as specified in Near-RT RIC Architecture [26]

5.3.3 O-CU-CP

The O-CU-CP terminates the NG-c, X2-c, Xn-c, F1-c, and E1 interfaces as well as the RRC and PDCP (for SRB) protocols towards the UE as specified in ETSI TS 138 401 [10].

The O-CU-CP terminates E2 interface to Near-RT RIC as specified in E2GAP [22].

The O-CU-CP is managed via O1 interface by the SMO as specified in OAM Architecture [34].

The O-CU-CP terminates NG-c interface to 5GC as specified in ETSI TS 138 300 [8].

The O-CU-CP terminates X2-c interface to O-eNB (in case O-eNB is an O-RAN eNB), eNB, or to en-gNB in EN-DC as specified in ETSI TS 136 420 [6] and ETSI TS 138 300 [8].

The O-CU-CP terminates Xn-c to O-CU-UP, O-eNB (in case O-eNB is an O-RAN ng-eNB), gNB, or to ng-eNB as specified in ETSI TS 138 300 [8] and ETSI TS 138 420 [12].

5.3.4 O-CU-UP

The O-CU-UP terminates the NG-u, X2-u, S1-u, Xn-u, F1-u, and E1 interfaces as well as the PDCP and SDAP protocols towards the UE as specified in ETSI TS 138 401 [10].

The O-CU-UP terminates E2 interface to Near-RT RIC as specified in E2GAP [22].

The O-CU-UP is managed via O1 interface by the SMO as specified in OAM Architecture [34].

The O-CU-UP terminates NG-u interface to 5GC as specified in ETSI TS 138 300 [8].

The O-CU-UP terminates X2-u interface to O-eNB (in case O-eNB is an O-RAN eNB), eNB, or to en-gNB in EN-DC as specified in ETSI TS 136 420 [6] and ETSI TS 138 300 [8].

The O-CU-UP terminates Xn-u to O-CU-UP, O-eNB (in case O-eNB is an O-RAN ng-eNB), gNB, or to ng-eNB as specified in ETSI TS 138 300 [8] and ETSI TS 138 420 [12].

5.3.5 O-DU

The O-DU is an O-RAN NF in the O-RAN Architecture. An O-DU, combined with one or more O-RU(s) connected to it, supports and is fully compatible with the functions of a gNB-DU as defined by ETSI TS 138 401 [10].

The O-DU may be implemented either by virtualized or non-virtualized methods.

The O-DU terminates the E2 and the F1 interface (according to the principles described in clause 5.4.9), and the Open Fronthaul interface (also known as LLS interface as specified in Open FH CUS-Plane [19]) as well as the RLC, MAC, and High-PHY functions of the radio interface towards the UE.

The O-DU is managed via O1 interface by the SMO as specified in OAM Architecture [34].

The O-DU terminates the Open Fronthaul M-Plane interface, towards the O-RU, to support O-RU management either in hierarchical model or hybrid model, as specified in Open FH M-Plane [24].

The O-DU terminates the D2 interface as specified in D2GAP [40] towards a peer O-DU, to support the inter O-DU NR carrier aggregation across O-DUs connected to same O-CU-CP.

The O-DU may support CTI to a TN to control UL bandwidth allocation to TUs for UL LLS traffic on shared point-to-multipoint transport network (TN is a PON OLT or DOCSIS CMTS, TU is a PON ONU or DOCSIS Cable Modem). The CTI is specified in CTI Control [20] and CTI Management [21]. An informative overview of the CTI is shown in Annex A.

5.3.6 O-RU

The O-RU terminates the Open Fronthaul interface (also known as LLS interface as specified in Open FH CUS-Plane [19]) as well as Low-PHY functions of the radio interface towards the UE. This is deployed as a PNF.

The O-RU terminates the Open Fronthaul M-Plane interface towards the O-DU and SMO as specified in Open FH M-Plane [24].

5.3.7 O-eNB

In case O-eNB is an O-RAN O-eNB, O-eNB terminates the S1, X2, O1 and E2 interfaces as well as the RRC, PDCP, RLC, MAC, and PHY layers of the LTE-Uu radio interface towards the UE as specified in ETSI TS 136 401 [4]. In case O-eNB is an O-RAN ng-eNB, O-eNB terminates the NG, Xn, O1, and E2 interfaces as well as the RRC, SDAP, NR PDCP, RLC, MAC, and PHY layers of the LTE-Uu radio interface towards the UE as specified in ETSI TS 138 401 [10].

In case O-eNB is an O-RAN ng-eNB:

- the O-eNB terminates E2 interface to Near-RT RIC as specified in E2GAP [22];
- the O-eNB is managed via O1 interface by the SMO as specified in OAM Architecture [34];
- the O-eNB terminates NG interface to 5GC as specified in ETSI TS 138 300 [8];
- the O-eNB terminates Xn interface to O-eNB, gNB, ng-eNB, or O-CU-CP/O-CU-UP as specified in ETSI TS 138 300 [8] and ETSI TS 138 420 [12].

In case O-eNB is an O-RAN eNB,

- the O-eNB terminates E2 interface to Near-RT RIC as specified in E2GAP [22];
- the O-eNB is managed via O1 interface by the SMO as specified in OAM Architecture [34];
- the O-eNB terminates S1 interface to EPC as specified in ETSI TS 136 401 [4];
- the O-eNB terminates X2 interface to O-eNB, eNB, en-gNB, or O-CU-CP/O-CU-UP as specified in ETSI TS 136 401 [4] and ETSI TS 138 420 [12].

The O-eNB supports O-DU and O-RU O-RAN NFs with an Open Fronthaul interface between them as specified in Open FH CUS-Plane [19] and Open FH M-Plane [24].

5.3.8 O-Cloud

O-Cloud is a cloud computing platform comprising a collection of physical infrastructure nodes that meet O-RAN requirements to host the relevant O-RAN NFs (i.e. Near-RT RIC, O-CU-CP, O-CU-UP, and O-DU), the supporting software components (such as Operating System, Virtual Machine Monitor, Container Runtime, etc.), and the appropriate management and orchestration functions which satisfy the following criteria:

- Exposes the O-RAN O2 interface for cloud and workload management to provide functions such as infrastructure discovery, registration, software lifecycle management, workload lifecycle management, fault management, performance management, and configuration management.
- Exposes O-RAN AAL API towards the hosted O-RAN workloads for hardware accelerator management.
- Exposes O-Cloud Notification interface towards the hosted O-RAN workloads in order to notify the workloads of critical notifications (e.g. PTP synchronization states).
- The virtualization of the O-RU is not supported in the present document.

5.4 Relevant interfaces in O-RAN architecture

5.4.1 Introduction to relevant interfaces in O-RAN architecture

The following interfaces are defined and maintained by O-RAN:

- A1 interface
- O1 interface
- O2 interface
- E2 interface
- Y1 interface
- O-Cloud Notification interface
- Open Fronthaul interface
- R1 interface
- Near-RT RIC APIs
- D2 interface

The following interfaces are defined and maintained by 3GPP, but seen also as part of the O-RAN architecture:

- E1 interface
- F1-c interface
- F1-u interface
- NG-c interface
- NG-u interface
- X2-c interface
- X2-u interface
- Xn-c interface
- Xn-u interface

- Uu interface

Following clauses describe the termination points of O-RAN defined interfaces and 3GPP interfaces adopted by O-RAN.

5.4.2 A1 interface

A1 interface is between Non-RT-RIC and the Near-RT RIC as specified in A1GAP [18].

A1 is the interface between the Non-RT RIC in SMO and the Near-RT RIC function O-RAN NF. A1 interface supports three types of services as defined in A1GAP [18]:

- Policy Management Service
- Enrichment Information Service
- ML Model Management Service

A1 policies have the following characteristics compared to persistent configuration as specified in A1GAP [18] and Use Cases Detailed Specification [38]. A1 policies:

- are not critical to traffic;
- have temporary validity;
- may handle individual UE or dynamically defined groups of UEs;
- act within and take precedence over the configuration;
- are non-persistent, i.e. do not survive a restart of the Near-RT RIC.

5.4.3 O1 interface

The O1 interface is used by SMO for the management of the O-RAN NFs as defined in OAM Architecture [34] and OAM Interface [31].

5.4.4 O2 interface

The O2 interface is between the SMO and O-Cloud as introduced in O2GAP [33]. The O2 interface provides two categories of services - O2 deployment management services (O2dms) and O2 infrastructure management services (O2ims).

5.4.5 E2 interface

E2 is a logical interface connecting the Near-RT RIC with an E2 Node as defined in E2GAP [22]:

- An E2 Node is connected to only one Near-RT RIC.
- A Near-RT RIC can be connected to multiple E2 Nodes.

The E2 interface is a control plane interface that provides support for Near-RT RIC Services using E2 Application Protocol and E2 Services Models as specified in E2GAP [22].

5.4.6 O-Cloud Notification interface

The O-Cloud Notification interface allows event consumer such as an O-DU deployed on O-Cloud to subscribe to events/status from the O-Cloud. The cloud infrastructure will provide event producer to enable cloud workloads to receive events/status that might be known only to the infrastructure.

5.4.7 Open Fronthaul interface

The Open FH (Fronthaul) interface is between O-DU and O-RU logical nodes as specified in Open FH CUS-Plane [19] and Open FH M-Plane [24]. The Open FH interface includes the CUS (Control User Synchronization) Plane and M (Management) Plane. In hybrid mode, the Open FH M-Plane interface connects the O-RU to the SMO for FCAPS functionality.

5.4.8 E1 interface

The E1 interface, as defined by 3GPP, is between the gNB-CU-CP and gNB-CU-UP logical nodes as specified in ETSI TS 138 401 [10] and ETSI TS 138 460 [14]. In O-RAN, it reuses the principles and protocol stack defined by 3GPP but is adopted between the O-CU-CP and the O-CU-UP logical nodes.

5.4.9 F1-c interface

The F1-c interface, as defined by 3GPP, is between the gNB-CU-CP and gNB-DU logical nodes as specified in ETSI TS 138 401 [10] and ETSI TS 138 470 [16]. In O-RAN, it reuses the principles and protocol stack defined by 3GPP but is adopted between the O-CU-CP and the O-DU logical nodes, as well as for the definition of interoperability profile specifications.

5.4.10 F1-u interface

The F1-u interface, as defined by 3GPP, is between the gNB-CU-UP and gNB-DU logical nodes as specified in ETSI TS 138 401 [10] and ETSI TS 138 470 [16]. In O-RAN, it reuses the principles and protocol stack defined by 3GPP but is adopted between the O-CU-UP and the O-DU logical nodes, as well as for the definition of interoperability profile specifications.

5.4.11 NG-c interface

The NG-c interface, as defined by 3GPP, is between the gNB-CU-CP and the AMF in the 5GC as specified in ETSI TS 138 300 [8]. It is also referred as N2 in ETSI TS 138 300 [8]. In O-RAN, it reuses the principles and protocol stack defined by 3GPP but is adopted between the O-CU-CP and the 5GC.

5.4.12 NG-u interface

The NG-u interface, as defined by 3GPP, is between the gNB-CU-UP and the UPF in the 5GC as specified in ETSI TS 138 300 [8]. It is also referred as N3 in ETSI TS 138 300 [8]. In O-RAN, it reuses the principles and protocol stack defined by 3GPP but is adopted between the O-CU-UP and the 5GC.

5.4.13 X2-c interface

The X2-c interface is defined in 3GPP for transmitting control plane information between eNBs or between eNB and en-gNB in EN-DC as specified in ETSI TS 136 420 [6] and ETSI TS 138 300 [8]. In O-RAN, it reuses the principles and protocol stack defined by 3GPP but is adopted for the definition of interoperability profile specifications.

5.4.14 X2-u interface

The X2-u interface is defined in 3GPP for transmitting user plane information between eNBs or between eNB and en-gNB in EN-DC as specified in ETSI TS 136 420 [6] and ETSI TS 138 300 [8]. In O-RAN, it reuses the principles and protocol stack defined by 3GPP but is adopted for the definition of interoperability profile specifications.

5.4.15 Xn-c interface

The Xn-c interface is defined in 3GPP for transmitting control plane information between gNBs, ng-eNBs or between ng-eNB and gNB as specified in ETSI TS 138 300 [8] and ETSI TS 138 420 [12]. In O-RAN, it reuses the principles and protocol stack defined by 3GPP but is adopted for the definition of interoperability profile specifications.

5.4.16 Xn-u interface

The Xn-u interface is defined in 3GPP for transmitting user plane information between gNBs, ng-eNBs or between ng-eNB and gNB as specified in ETSI TS 138 300 [8] and ETSI TS 138 420 [12]. In O-RAN, it reuses the principles and protocol stack defined by 3GPP but is adopted for the definition of interoperability profile specifications.

5.4.17 Uu interface

The UE to eNB/gNB interface in 3GPP is denoted as the Uu interface. The Uu is a complete protocol stack from L1 to L3 and as such, seen as a whole, it terminates in the NG-RAN. If the NG-RAN is decomposed, different protocols terminate at different reference points and none of them has been defined by O-RAN. Since the Uu messages still flow from the UE to the intended eNB/gNB managed function, it is not shown in the O-RAN architecture as a separate interface to a specific managed function. For more information on the Uu interface between the UE and the NG-RAN, Refer to clauses 5.2 and 5.3 of ETSI TS 138 401 [10].

5.4.18 CTI (Cooperative Transport Interface)

Interface between the O-DU and TN to dynamically control bandwidth allocations to TUs when using a shared point-to-multipoint transport network. The CTI is specified in CTI Control [20] and CTI Management [21].

5.4.19 Y1 interface

Y1 service interface as specified in Y1GAP [39] allows the Y1 consumers to subscribe or request the RAN analytics information provided by Near-RT RIC.

5.4.20 R1 interface

The R1 interface is a service-based interface between the rApps and the Non-RT RIC framework via which R1 services can be produced and consumed as specified in Non-RT RIC Architecture [27].

The producers of R1 services can be part of the Non-RT RIC and/or the SMO Framework. R1 services are specified in R1GAP [35].

5.4.21 Near-RT RIC APIs

The Near-RT RIC APIs are a set of service-based interfaces that can be produced and consumed by the Near-RT RIC Platform and xApps as specified in Near-RT RIC Architecture [26].

5.4.22 D2 interface

The D2 interface is between two O-DU nodes connected to the same O-CU-CP. O-CU-UP for both the O-DUs can be same or different. One O-DU can be connected to multiple O-DUs. D2 interface is used for supporting inter O-DU NR carrier aggregation across O-DUs. An O-DU can be a PCell O-DU for a particular UE and a SCell O-DU for another UE at the same time.

5.5 UE associated identifiers used in O-RAN

As described earlier (clauses 5.3.1 and 5.3.2), the Non-RT RIC and Near-RT RIC enable intelligent RAN optimization via A1, O1 and E2 interfaces respectively.

To support intelligent RAN optimization, the Non-RT RIC with rApps and Near-RT RIC with xApps utilize the knowledge of different UE associated events reported by the O-RAN NFs (excluding O-RU) over E2 and O1 interfaces. Both the Non-RT RIC and Near-RT RIC may need to correlate different UE associated events reported by the O-RAN functions for the same UE. In order to facilitate this correlation task, the reporting O-RAN NF includes a set of UE associated identifiers with any report containing UE specific information.

Table 5.5-1 below shows the set of UE associated identifiers to be reported by any O-RAN NF (excluding O-RU) over O1 and E2 interfaces for any UE associated information.

Table 5.5-1: UE associate identifiers used in O-RAN

UE associated identifier	Reference Specification	Comments
AMF UE NGAP ID	ETSI TS 138 413 [11]	Reported by O-CU-CP and O-eNB for UEs connected to 5GC.
GUAMI	ETSI TS 138 413 [11]	Reported by O-CU-CP and O-eNB for UEs connected to 5GC.
MME UE S1AP ID	ETSI TS 136 413 [5]	Reported by O-eNB for UEs connected to EPC.
GUMMEI	ETSI TS 136 413 [5]	Reported by O-eNB for UEs connected to EPC.
gNB-CU UE F1AP ID	ETSI TS 138 473 [17]	Reported by O-CU-CP and O-DU.
gNB-CU-CP UE E1AP ID	ETSI TS 138 463 [15]	Reported by O-CU-CP and O-CU-UP.
RAN UE ID	ETSI TS 138 473 [17] ETSI TS 138 463 [15]	Reported by O-CU-CP, O-CU-UP and O-DU when available/allocated.
M-NG-RAN node UE XnAP ID	ETSI TS 138 423 [13]	Identifier reported when the UE operates in DC with 5GC. Reported by O-CU-CP and O-eNB.
Global NG-RAN Node ID	ETSI TS 138 423 [13]	Identifier reported when the UE operates in DC with 5GC. Identifies the peer gNB/ng-eNB and is reported in conjunction with the M-NG-RAN node UE XnAP ID to ensure that the UE can be uniquely identified over Xn interface. Reported by O-eNB and O-CU-CP.
MeNB UE X2AP ID	ETSI TS 136 423 [7]	Identifier reported when the UE operate in DC with EPC. Reported by O-CU-CP and O-eNB.
Global eNB ID	ETSI TS 136 423 [7]	Identifier reported when the UE operate in DC with EPC. Identifies the peer eNB and is reported in conjunction with the MeNB UE X2AP ID to ensure that the UE can be uniquely identified over X2 interface. Reported by O-CU-CP and O-eNB.
C-RNTI (Cell Radio Network Temporary Identifier)	ETSI TS 138 331 [9]	Optionally reported by O-CU-CP, O-DU and O-eNB.

Additionally, the Non-RT RIC and Near-RT RIC may initiate messages towards the O-RAN NFs which are associated with specific UEs. In such cases, the Non-RT RIC and Near RT RIC may include one or more of the UE associated identifiers specified in Table 5.5-1 above with any UE associated messages over A1 and E2 interface for identification of the UE in the O-RAN NFs.

5.6 O-RAN security architecture

The goals of the O-RAN ALLIANCE are to achieve a secure, open, and interoperable RAN. Building upon security advancements from the 3GPP and IETF standards development organizations, the O-RAN ALLIANCE specifies an O-RAN security architecture with the goal to enable 5G CSPs (Communication Service Provider) to deploy and operate O-RAN with the same, or higher level of confidence as a 3GPP-specified RAN. The O-RAN ALLIANCE is strengthening O-RAN's security posture by specifying security requirements and security controls that mitigate risk across its attack surface while pursuing the goals of a ZTA (Zero-Trust Architecture).

The O-RAN security architecture is specified in the following two O-RAN Technical Specifications:

- Security Protocols Specifications [36]
- Security Requirements and Controls Specifications [37]

The above TSs, Security Protocols Specifications [36] and Security Requirements and Controls Specifications [37], include specifications for configuration and cipher suites with use of the following security protocols on O-RAN interfaces to ensure confidentiality, integrity, availability, and authenticity: SSHv2 (Secure Shell 2.0), TLS 1.2 and 1.3, DTLS (Datagram Transport Layer Security) 1.2, IPsec (Internet Protocol Security), OAuth 2.0, CMPv2, IEEE 802.1X, and NETCONF (Network Configuration Protocol) over Secure Transport.

O-RAN has also provided requirements for SBOM (Software Bill of Materials) in Security Requirements and Controls Specifications [37].

The test cases to verify proper security implementation of O-RAN security architecture is specified in the O-RAN Technical Specification:

- O-RAN Security Tests Specifications [32]

The threats to the O-RAN architecture and the risk assessment are documented in the TR mentioned below:

- O-RAN Security Threat Modeling and Risk Assessment [i.4]

The security threat modelling and risk analysis is used to derive the security requirements and security controls in the Security Requirements and Controls Specifications [37]. The O-RAN Security Threat Modeling and Risk Assessment [i.4] considers external and internal threats to achieve a ZTA. In addition, security analysis TRs are maintained for O-RAN NFs and features. These TRs help to drive the requirements in the O-RAN security specifications.

NOTE: Internal and external threats are considered in a ZTA, as defined in NIST SP 800-207 [i.6]. Achieving a ZTA is an incremental process, as identified by the United States Department of Homeland Security's Cybersecurity and Infrastructure Security Agency in Zero Trust Maturity Model [i.7]. The O-RAN ALLIANCE is continuing to pursue a ZTA as the O-RAN architecture, threats, and controls evolve.

6 O-RAN Information Model (IM) principles

O-RAN shall align its Information Model (IM) with 3GPP to the extent possible. The additional O-RAN extensions to its IM and DMs (Data Model) are described in O-RAN Information Model and Data Models Specification [30].

Annex A (informative): Implementation options of O-RAN functions and network elements

A.1 Shared cell

Shared cell, as specified in Open FH CUS-Plane [19], is defined as the operation for the same cell by several O-RUs with one or multiple component carriers. It can be deployed in either FHM (Fronthaul Multiplexer) or Cascade mode as described below.

In FHM mode, the shared cell may be realized by placing an FHM function between an O-DU and several O-RUs that may have one or multiple component carriers from these O-RUs. FHM function may be modelled as an O-RU with LLS Fronthaul support (same as normal O-RU) along with the copy and combine function (additional to normal O-RU), but without radio transmission/reception capability. Figure A.1-1 below shows how each O-RU can be used for either operating in the same cell (Single Cell Scenario) or in different cells (Multiple Cells Scenario) by configuring the FHM function.

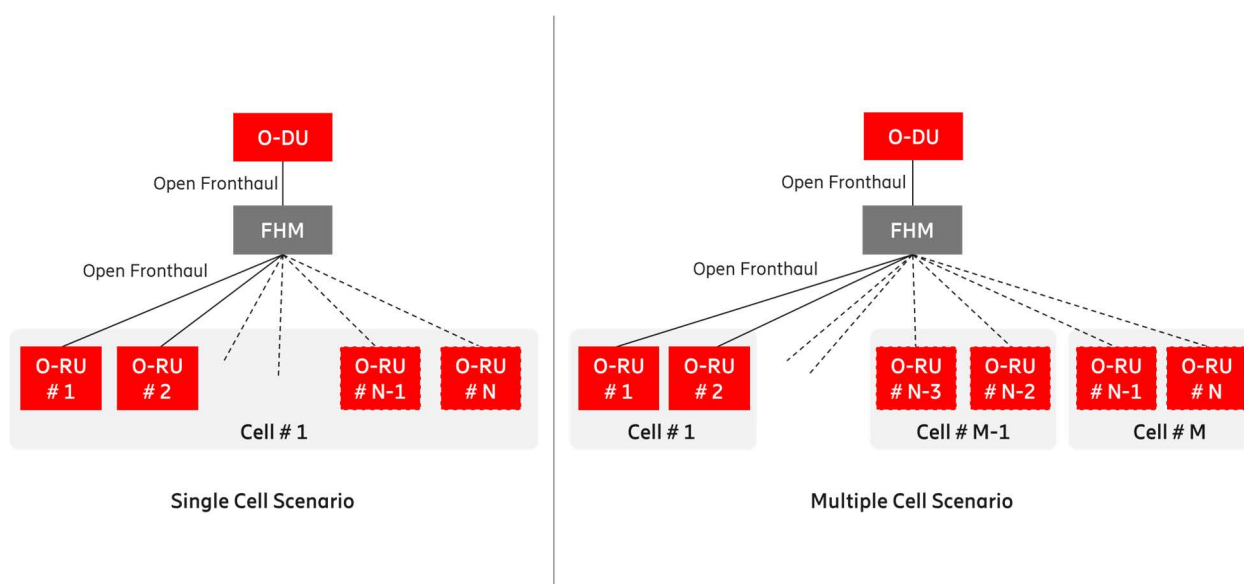

Figure A.1-1: Shared cell deployment using FHM mode

In Cascade mode, the shared cell is realized by several O-RUs cascaded in chain. In this case, one or more O-RUs are inserted between the O-DU and the O-RU. The O-RUs in the cascaded chain except for the last O-RU support Copy and Combine function. Figure A.1-2 below shows an implementation of Cascade mode shared cell.

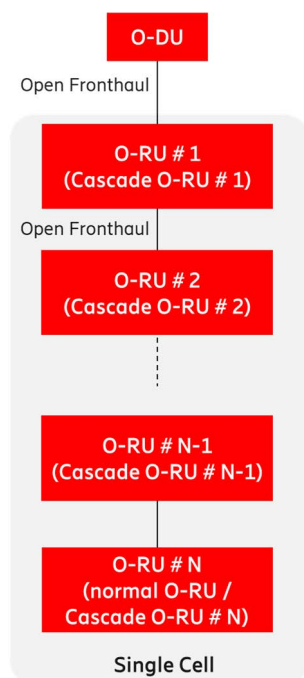

Figure A.1-2: Shared cell deployment using Cascade mode

The Cascade mode, as described above, is implemented within the O-RU.

Refer to Open FH CUS-Plane [19] for additional information.

A.2 FHGW function

The FHGW (Fronthaul Gateway) function may be placed between the O-DU and RU/RRU (Radio Unit/Remote Radio Unit) with the following O-RAN specified interfaces:

- The interface between O-DU and FHGW function is Open Fronthaul (Option 7-2x).
- The interface between FHGW function and RU/RRU is subject to reference implementation developed by any relevant O-RAN WG (e.g. WG7) as described in Hardware Reference Design Specification for Indoor Picocell FR1 with Split Architecture Option 8 [23].
- The interface between FHGW function and RU/RRU does not support Open Fronthaul (Option 7-2x).
- The FHGW function may be packaged with other functions (such as Ethernet switching) in a physical product, as considered within WG7.

Figure A.2-1 below depicts the deployment of the FHGW function using O-RAN specified interfaces.

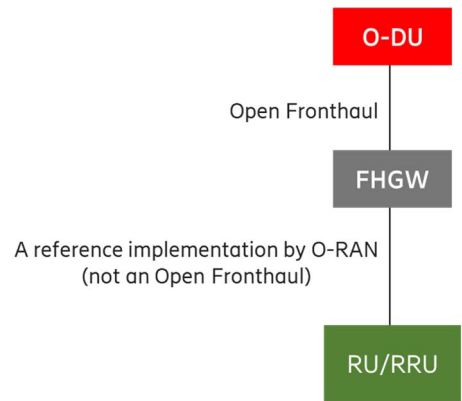

Figure A.2-1: Deployment of O-DU and RU/RRU using FHGW function

A.3 Near-RT RIC

The Near-RT RIC can control multiple E2 Nodes or can control a single E2 Node. The following figures show two implementation options of Near-RT RIC.

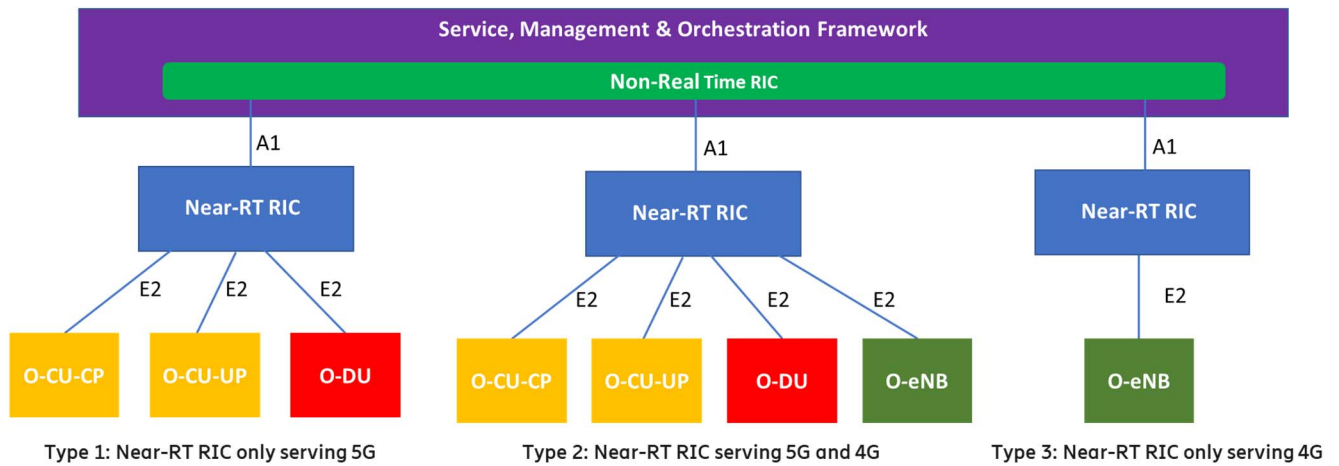

Figure A.3-1: Centralized Near-RT RIC Serving 4G and 5G Simultaneously

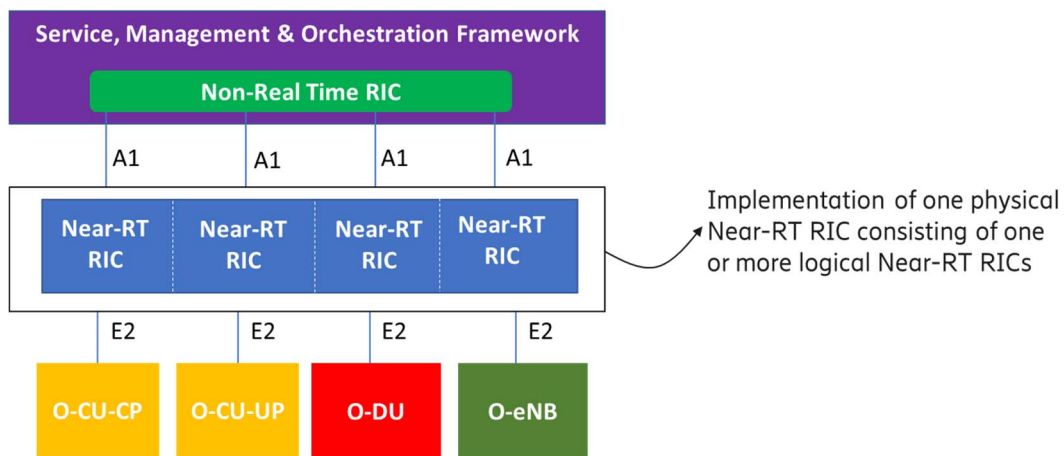

Figure A.3-2: Distributed Near-RT RIC

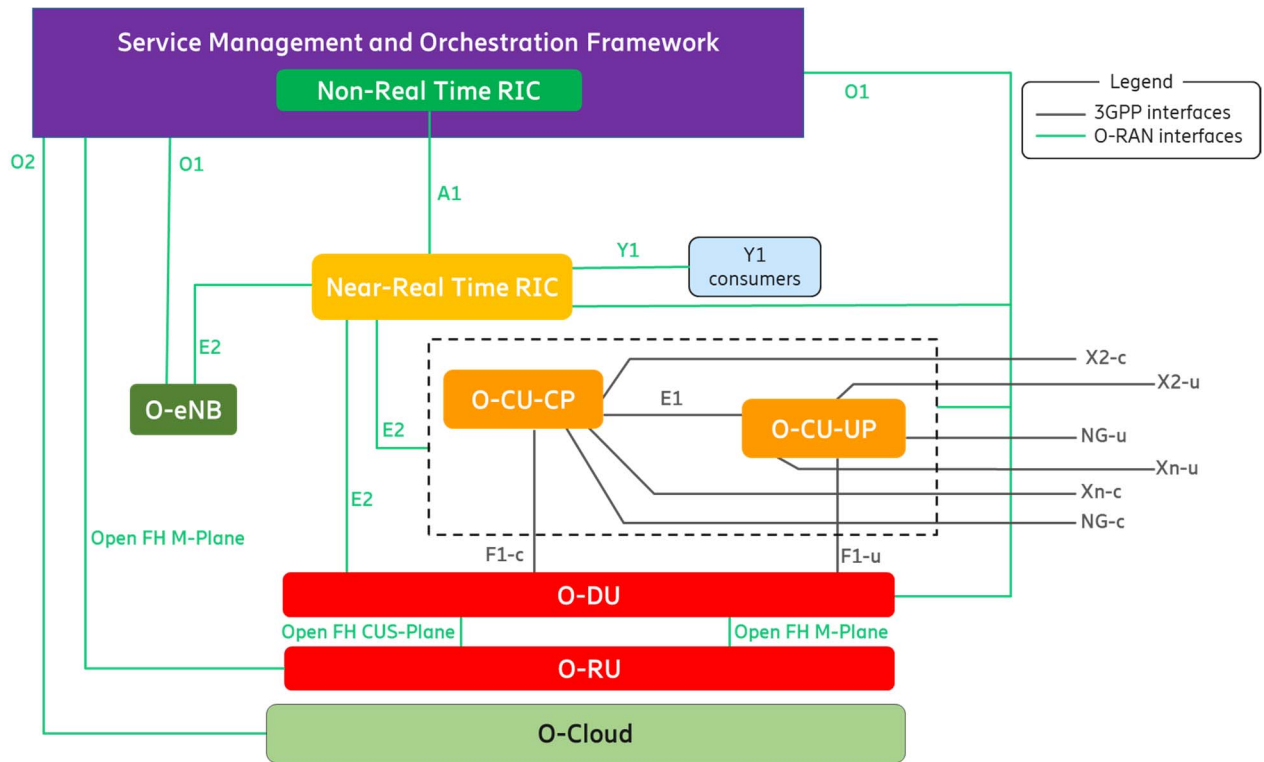

Figure A.4-2: Aggregated O-CU-CP and O-CU-UP

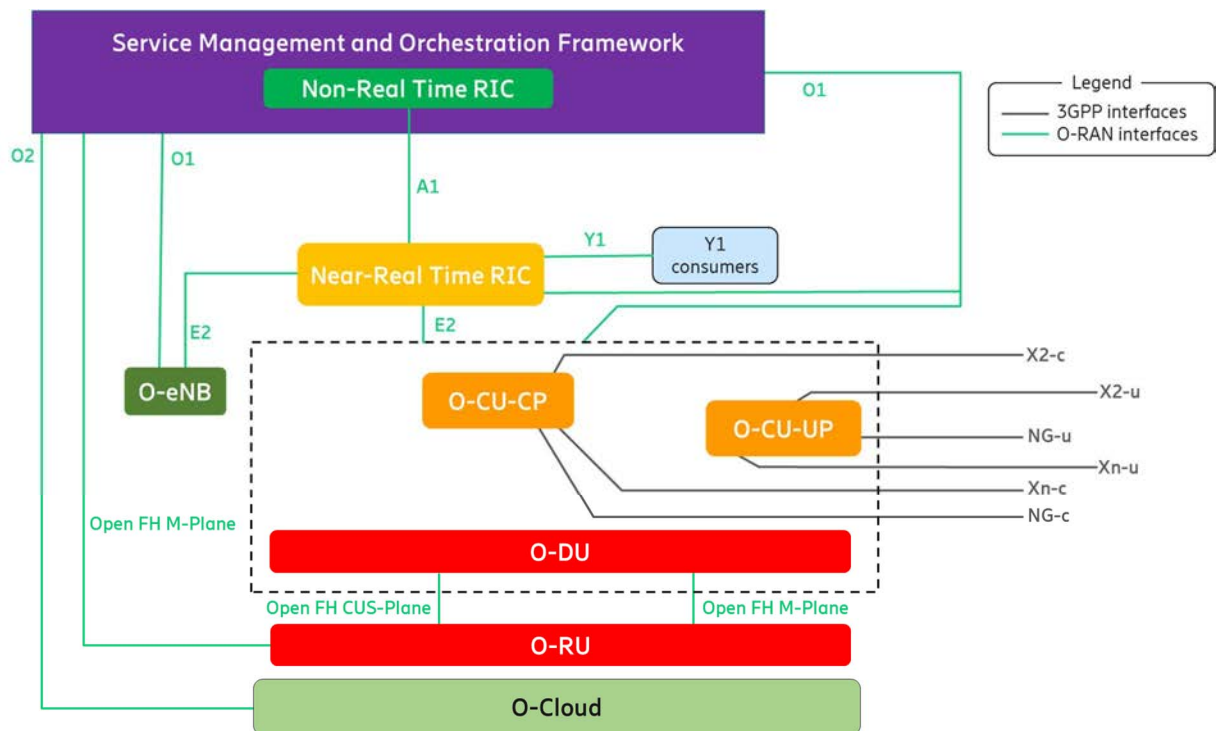

Figure A.4-3: Aggregated O-CU-CP, O-CU-UP, and O-DU

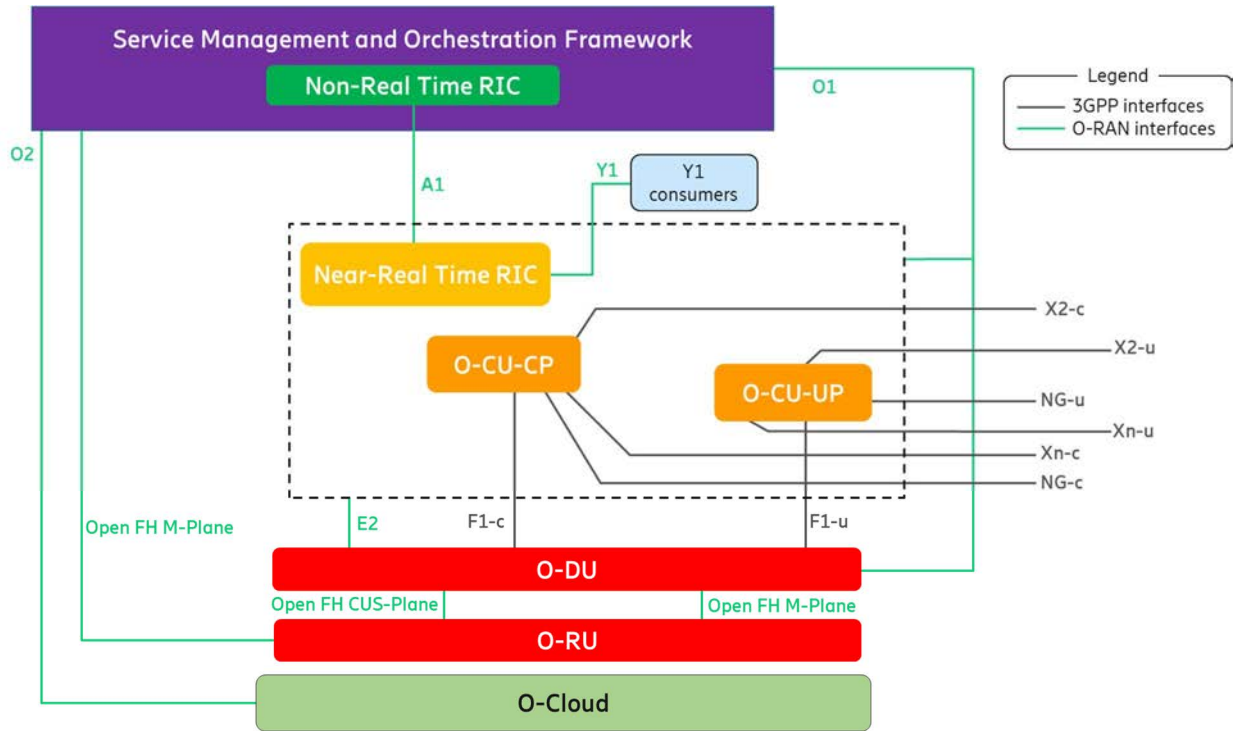

Figure A.4-4: Aggregated Near-RT RIC, O-CU-CP, and O-CU-UP

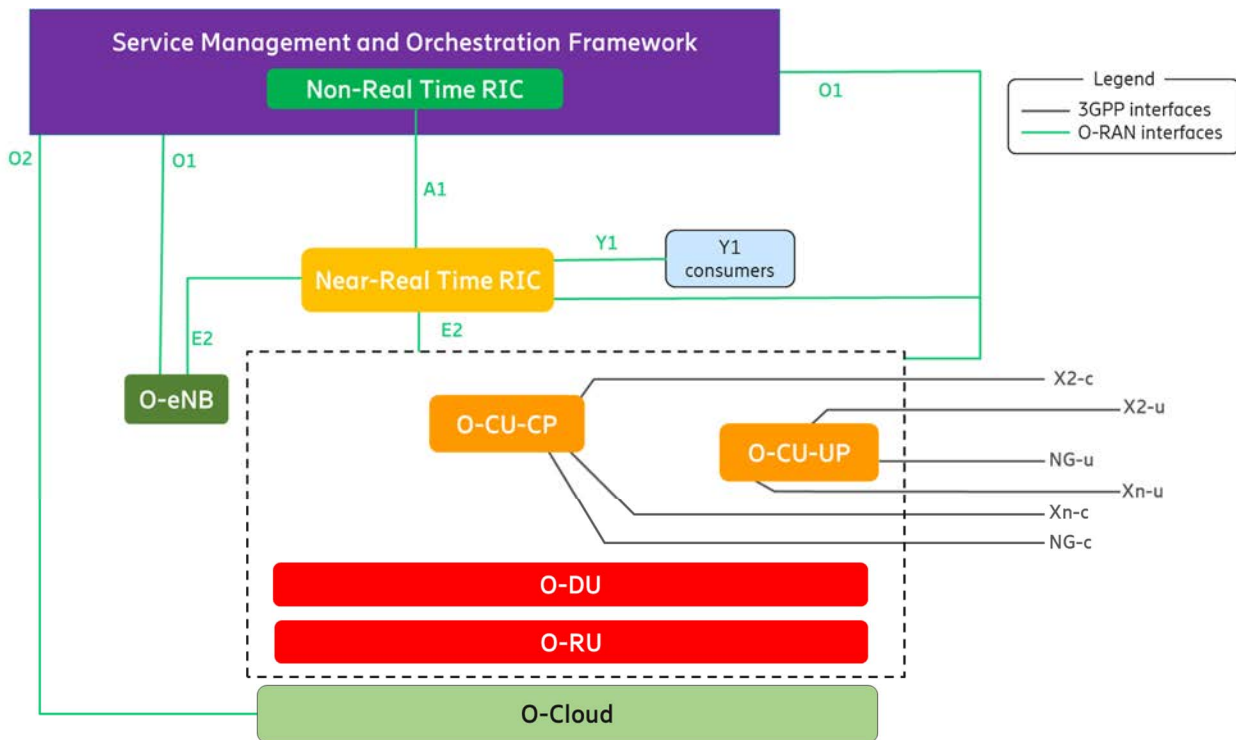

Figure A.4-5: Aggregated O-CU-CP, O-CU-UP, O-DU, and O-RU

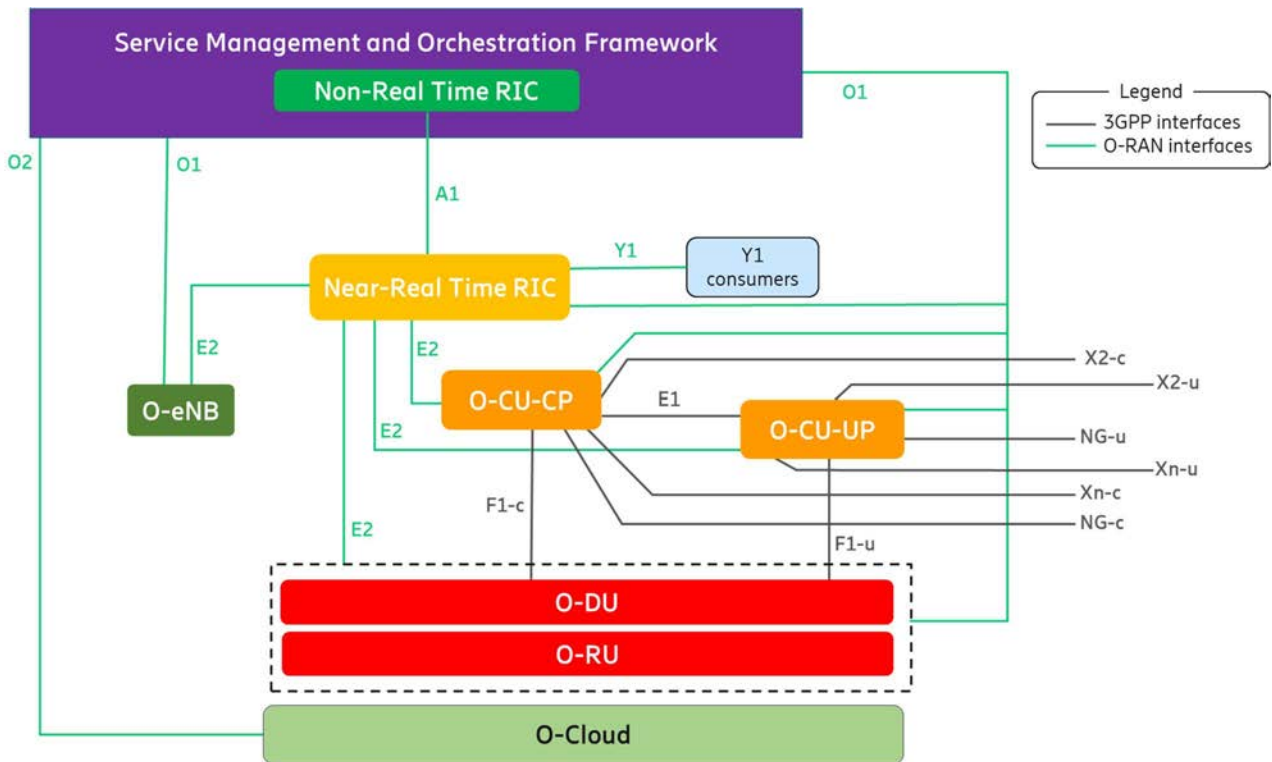

Figure A.4-6: Aggregated O-DU and O-RU

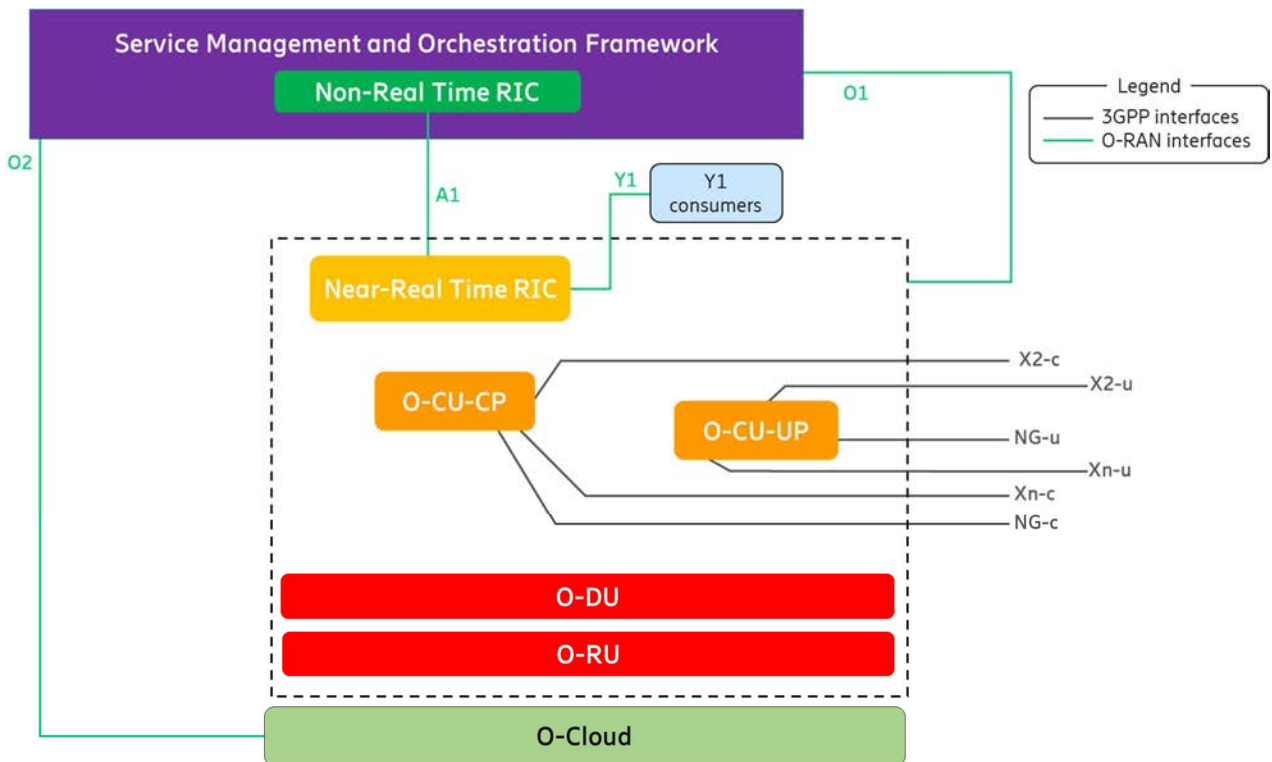
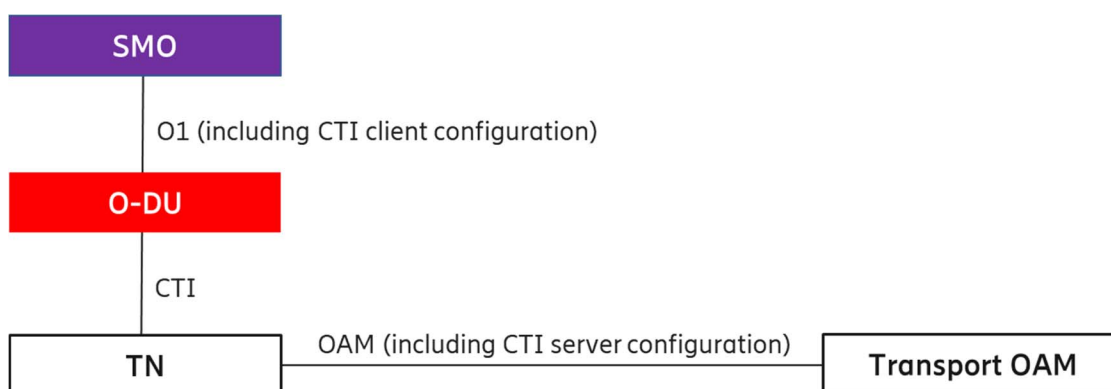

Figure A.4-7: Aggregated Near-RT RIC, O-CU-CP, O-CU-UP, O-DU, and O-RU

A.5 Cooperative transport

To enhance the resource utilization and reduce the latency of UL LLS traffic when using a shared point-to-multipoint transport network requiring resource allocation (such as PON or DOCSIS), the O-RAN architecture supports a cooperative transport feature. The cooperative transport feature is based on the O-DU's knowledge of the expected uplink LLS traffic from a given O-RU which is provided to the associated (PON or DOCSIS) TN in the transport network. This enables the TN to dynamically allocate the correct bandwidth over the shared transport network to the TU that is used by the O-RU. The CTI signalling is described in CTI Control [20]. To support the CTI, the O-DU is configured over the O1 interface with CTI client specific configuration as described in CTI Management [21]. When there are intermediate nodes between the O-DU and the TN, they will forward the CTI messages transparently but will not participate in CTI interactions.

A simplified architecture of the CTI is shown in figure A.5-1 below. The SMO, O-DU and O1 interface shown in this figure are part of the O-RAN Architecture (see clauses 5.3.1, 5.3.5, and 5.4.3, respectively), whereas the TN and Transport OAM, are the components of the transport network. For detailed specification and reference architecture, see CTI Control [20] and CTI Management [21].



A.5-1: Simplified CTI Architecture

A.6 Inter O-DU Carrier Aggregation (CA)

The D2 interface is used for supporting carrier aggregation across cells configured in the different O-DUs as specified in D2GAP [40]. In the present document, DL CA is supported by the D2 interface that includes D2-c and D2-u.

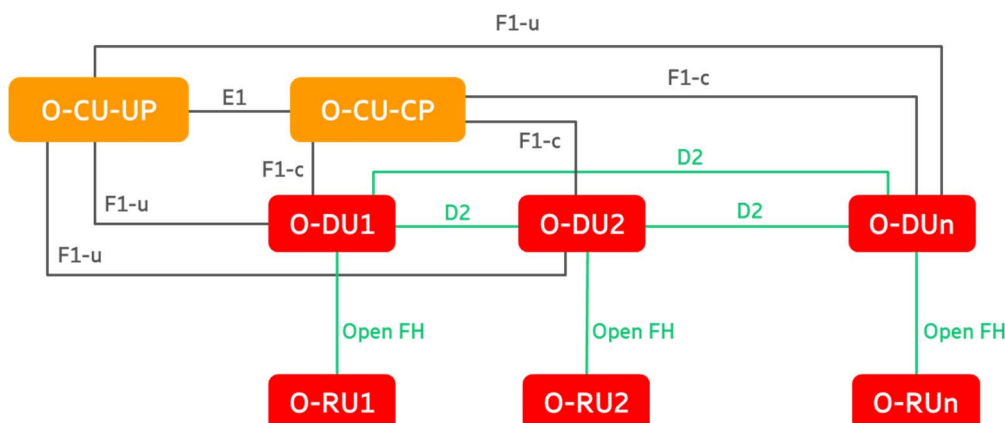

A.6-1: Inter O-DU CA

Annex B (informative): Change history

Date	Revision	Description
2020.01.16	01.00	<ul style="list-style-type: none"> • First version with an overall architecture of O-RAN. • Describe O-RAN architecture elements and relevant interfaces.
2020.10.30	02.00	<ul style="list-style-type: none"> • Introduce new implementation options by bundling O-RAN logical functions. • Clarify the O-RAN position that OFH (7-2x) is the interface between O-DU and O-RU. • Add a new principle that architecture may evolve as deemed appropriate by the O-RAN community.
2020.11.25	03.00	<ul style="list-style-type: none"> • Introduce functional architecture of Non-RT RIC with description of rApps, R1 interface, and Non-RT RIC framework. • Add implementation options of FHM and FHGW functions. • Remove the optionality of SMO to support OFH M-Plane interface towards O-RU. • Add definition of "Managed Application". • Add 'legends' to the architecture figures.
2021.03.18	04.00	<ul style="list-style-type: none"> • Enhance O-RAN control loops by making their execution times and interactions dependent on use cases. • Explain that the execution times of Non-RT and Near-RT control loops may overlap as dictated by use cases. • Designate the O1 interface between SMO and O-RU as a topic for future study. • Use two colours (i.e. green for O-RAN and black for 3GPP) for the logical interfaces in the architecture figures.
2021.07.16	05.00	<ul style="list-style-type: none"> • Elaborate the relationship between rApps, R1 interface, Non-RT RIC framework, and SMO framework within Non-RT RIC functional architecture. • Introduce the concept of 'anchored' vs. 'non-anchored' functionality within SMO and Non-RT RIC frameworks. • Provide a high-level view of 'functions' required to enable the capabilities of rApps. • Add a CTI clause and an Annex clause containing a simple CTI implementation.
2021.11.18	06.00	<ul style="list-style-type: none"> • Clarify how R1 interface works between rApps and O-RAN logical functions. • Extend the "OFH M-Plane" interface between SMO and O-RU. • Add 'UE Associated Identifiers Used in O-RAN' clause for correlating UE identities. • Introduce "O-Cloud Notification" interface between O-RAN functions and O-Cloud. • Add "O-RAN Security Architecture" clause consisting of 'Threat Analysis', 'Attack Surfaces', and 'Security Protocols'.
2022.10.21	07.00	<ul style="list-style-type: none"> • Add the concept of SBA as part of the "SMO Architecture Principles" clause. • Implement changes (i.e. new legal statement in cover page, revised foot note, and deletion of annex ZZZ) to be compliant with the new IPR policy of O-RAN ALLIANCE.
2022.11.17	08.00	<ul style="list-style-type: none"> • Introduce new Y1 interface for exposing RAN analytics information to internal and/or external functions. • Remove all references to future work items (e.g. O1 interface between SMO and O-RU, planned security enhancements, etc.) to align with the O-RAN drafting rules. • Add C-RNTI to UE identifier so that it can be optionally reported by O-CU-CP, O-DU, and O-eNB.
2023.03.25	09.00	<ul style="list-style-type: none"> • Elucidate the role of Y1 consumers within or outside the PLMN trust domain. • Clarify that the Y1 consumers box depicted in figures is not a logical O-RAN function. • Add definitions of "Y1", "Y1 consumers", "SMO External Interface", "SMO External System", "SMOFs", and "SMOS". • Enhance the description of O-DU to align it with the gNB-DU of 3GPP.

Date	Revision	Description
2023.07.27	10.00	<ul style="list-style-type: none"> • Eliminate terminology inconsistencies between O-RAN NF, O-RAN function, and O-RAN node. • Clarify that "O-RAN NF" and "O-RAN node" can be used interchangeably to denote an O-RAN logical entity, according to the context being described. • Add definition of "Cloudified NF". • Update O-eNB clause to be consistent with the description of other O-RAN nodes.
2023.11.21	11.00	<ul style="list-style-type: none"> • Clarify that O-RAN NF has "O-RAN defined behaviours and interfaces" but "can also inherit and/or extend" a 3GPP Network Function. • Remove "Cloudified NF" definition that addresses deployment aspects to keep the focus of this document on logical network view. • Add R1 interface and Near-RT RIC APIs to "Relevant Interfaces in O-RAN Architecture" clause. • Add text and figure to describe service-base representation of Near-RT architecture. • Simplify "O-RAN Security Architecture" clause by removing informative content and referring to relevant WG11 specifications. • Update relevant clauses to add testability, clarify that O-RAN does not conflict with 3GPP, and align with OAM architecture by representing O1 as a management service.
2024.03.29	12.00	<ul style="list-style-type: none"> • Revise the definitions of O-Cloud, Near-RT RIC, Near-RT RIC APIs, Near-RT RIC platform, xApp, Non-RT RIC, Non-RT RIC Framework, and rApp to align with ODR (O-RAN Drafting Rules). • Move all TR references to "Informative Reference" clause. • Add overlooked references and acronyms to their respective clauses. • Change O1 related "shall" statements to "is" statements to be consistent with current "Architecture Description".
2024.12.02	13.00	<ul style="list-style-type: none"> • Add Release 18 as the default 3GPP reference. • Include high-level concepts of Decoupled SMO TR. • Remove RRM terminology to avoid potential conflict with 3GPP specifications. • Clarify SMO southbound interfaces for FCAPS support in both hierarchical and hybrid models. • Include the example of Non-RT RIC SMOF consisting of rApps and A1 related SMOSs. • State that the O2 interface has deployment and infrastructure management services. • Add "Non-RT RIC" sub-clause within clause "5.3.1 SMO (Service Management and Orchestration)".
2025.03.30	14.00	<ul style="list-style-type: none"> • Add D2 interface. • Add description of SMOS Communication and R1 services. • Make editorial changes to align with ODR (O-RAN Document Drafting Rules).

History

Version	Date	Status
V8.0.0	January 2024	Publication
V14.0.0	March 2026	Publication