

ETSI TS 103 636-3 V1.1.1 (2020-07)



TECHNICAL SPECIFICATION

**DECT-2020 New Radio (NR);
Part 3: Physical layer;
Release 1**

Reference

DTS/DECT-00318

Keywordschannel coding, DECT-2020, IMT-2020,
modulation, NR, OFDM, Physical Layer, radio**ETSI**

650 Route des Lucioles
F-06921 Sophia Antipolis Cedex - FRANCE

Tel.: +33 4 92 94 42 00 Fax: +33 4 93 65 47 16

Siret N° 348 623 562 00017 - NAF 742 C
Association à but non lucratif enregistrée à la
Sous-Préfecture de Grasse (06) N° 7803/88

Important notice

The present document can be downloaded from:

<http://www.etsi.org/standards-search>

The present document may be made available in electronic versions and/or in print. The content of any electronic and/or print versions of the present document shall not be modified without the prior written authorization of ETSI. In case of any existing or perceived difference in contents between such versions and/or in print, the prevailing version of an ETSI deliverable is the one made publicly available in PDF format at www.etsi.org/deliver.

Users of the present document should be aware that the document may be subject to revision or change of status.

Information on the current status of this and other ETSI documents is available at

<https://portal.etsi.org/TB/ETSIDeliverableStatus.aspx>

If you find errors in the present document, please send your comment to one of the following services:

<https://portal.etsi.org/People/CommiteeSupportStaff.aspx>

Copyright Notification

No part may be reproduced or utilized in any form or by any means, electronic or mechanical, including photocopying and microfilm except as authorized by written permission of ETSI.

The content of the PDF version shall not be modified without the written authorization of ETSI.

The copyright and the foregoing restriction extend to reproduction in all media.

© ETSI 2020.

All rights reserved.

DECT™, **PLUGTESTS™**, **UMTS™** and the ETSI logo are trademarks of ETSI registered for the benefit of its Members.

3GPP™ and **LTE™** are trademarks of ETSI registered for the benefit of its Members and of the 3GPP Organizational Partners.

oneM2M™ logo is a trademark of ETSI registered for the benefit of its Members and of the oneM2M Partners.

GSM® and the GSM logo are trademarks registered and owned by the GSM Association.

Contents

Intellectual Property Rights	5
Foreword.....	5
Modal verbs terminology.....	5
1 Scope	6
2 References	6
2.1 Normative references	6
2.2 Informative references.....	6
3 Definition of terms, symbols and abbreviations.....	6
3.1 Terms.....	6
3.2 Symbols.....	6
3.3 Abbreviations	7
4 Physical layer principles.....	8
4.1 General description of Physical layer.....	8
4.2 Multiple access	9
4.3 Numerologies	9
4.4 Frame structure.....	10
4.5 Physical resources	10
5 Physical layer transmissions.....	14
5.1 Transmission packet structure	14
5.2 Physical resource mapping	15
5.2.1 Guard Interval (GI)	15
5.2.2 Synchronization Training Field (STF).....	15
5.2.3 Demodulation Reference Signal (DRS).....	16
5.2.4 Physical Control Channel (PCC)	16
5.2.5 Physical Data Channel (PDC).....	17
5.3 Transport block size	18
6 Generic procedures.....	19
6.1 Channel coding, rate-matching and interleaving	19
6.1.1 Overview	19
6.1.2 CRC calculation.....	19
6.1.3 Code block segmentation.....	19
6.1.4 Channel coding	21
6.1.4.1 Introduction.....	21
6.1.4.2 Turbo coding.....	21
6.1.4.2.1 Turbo encoder.....	21
6.1.4.2.2 Trellis termination for turbo encoder.....	22
6.1.4.2.3 Turbo code internal interleaver.....	23
6.1.5 Rate matching	24
6.1.5.1 Rate matching for turbo coded transport channels	24
6.1.5.2 Sub-block interleaver	25
6.1.5.3 Bit collection, selection and transmission	26
6.1.6 Code block concatenation.....	27
6.2 Pseudo-random sequence generation.....	28
6.3 Modulation	28
6.3.1 Symbol mapping	28
6.3.1.1 Overview	28
6.3.1.2 BPSK.....	28
6.3.1.3 QPSK	28
6.3.1.4 16-QAM.....	28
6.3.1.5 64-QAM.....	29
6.3.1.6 256-QAM.....	29
6.3.1.7 1024-QAM.....	29
6.3.2 Spatial multiplexing	29

6.3.3	Transmit stream mapping	30
6.3.3.1	Transmit stream mapping for spatial multiplexing and for single antenna	30
6.3.3.2	Transmit diversity precoding	30
6.3.4	Beamforming and antenna port mapping.....	31
6.3.5	OFDM signal generation	34
6.3.6	Cyclic prefix insertion	34
7	Transmission encoding.....	34
7.1	Transmitter block diagram	34
7.2	Transmission modes	35
7.3	Synchronization Training Field (STF) beamforming	35
7.4	Demodulation Reference Signal (DRS) beamforming	36
7.5	Physical Control Channel (PCC) encoding	36
7.5.1	Overall description.....	36
7.5.2	CRC calculation.....	36
7.5.2.1	Parity bit calculation	36
7.5.2.2	CRC Masking for MIMO closed loop.....	37
7.5.2.3	CRC Masking for beamforming.....	37
7.5.2.4	CRC attachment	37
7.5.3	Channel coding & rate matching	37
7.5.4	Scrambling	37
7.5.5	Symbol mapping.....	37
7.5.6	Spatial multiplexing	37
7.5.7	Transmit stream mapping	37
7.5.8	Beamforming	37
7.5.9	Subcarrier mapping.....	38
7.6	Physical Data Channel (PDC) encoding.....	38
7.6.1	Overall description.....	38
7.6.2	CRC calculation.....	38
7.6.3	Code block segmentation.....	38
7.6.4	Channel coding & rate matching	38
7.6.5	Code block concatenation.....	38
7.6.6	Scrambling	39
7.6.7	Symbol mapping.....	39
7.6.8	Spatial multiplexing	39
7.6.9	Transmit stream mapping	39
7.6.10	Beamforming and antenna port mapping.....	39
7.6.11	Subcarrier mapping.....	39
Annex A (normative):	Modulation and coding schemes.....	40
Annex B (normative):	Physical layer requirements for radio device classes.....	41
B.1	Introduction	41
B.2	Radio device class ($\mu, \beta, \text{NSS}, A$) = (1.1.1.A)	41
B.2.1	Transmission bandwidth.....	41
B.2.2	Transmission modes	41
B.2.3	Modulation and coding scheme.....	41
B.2.3.1	Modulation and coding	41
B.2.3.2	Hybrid ARQ processes	41
B.2.3.3	Soft buffer size.....	41
B.2.3.4	Code block segment size.....	41
Annex C (informative):	Transport block sizes and maximum achievable data rates	42
C.1	Single slot transmission, single spatial stream	42
History	45

Intellectual Property Rights

Essential patents

IPRs essential or potentially essential to normative deliverables may have been declared to ETSI. The information pertaining to these essential IPRs, if any, is publicly available for **ETSI members and non-members**, and can be found in ETSI SR 000 314: "*Intellectual Property Rights (IPRs); Essential, or potentially Essential, IPRs notified to ETSI in respect of ETSI standards*", which is available from the ETSI Secretariat. Latest updates are available on the ETSI Web server (<https://ipr.etsi.org>).

Pursuant to the ETSI IPR Policy, no investigation, including IPR searches, has been carried out by ETSI. No guarantee can be given as to the existence of other IPRs not referenced in ETSI SR 000 314 (or the updates on the ETSI Web server) which are, or may be, or may become, essential to the present document.

Trademarks

The present document may include trademarks and/or tradenames which are asserted and/or registered by their owners. ETSI claims no ownership of these except for any which are indicated as being the property of ETSI, and conveys no right to use or reproduce any trademark and/or tradename. Mention of those trademarks in the present document does not constitute an endorsement by ETSI of products, services or organizations associated with those trademarks.

Foreword

This Technical Specification (TS) has been produced by ETSI Technical Committee Digital Enhanced Cordless Telecommunications (DECT).

The present document is part 3 of a multi-part deliverable. Full details of the entire series can be found in part 1 [1].

Modal verbs terminology

In the present document "**shall**", "**shall not**", "**should**", "**should not**", "**may**", "**need not**", "**will**", "**will not**", "**can**" and "**cannot**" are to be interpreted as described in clause 3.2 of the [ETSI Drafting Rules](#) (Verbal forms for the expression of provisions).

"**must**" and "**must not**" are **NOT** allowed in ETSI deliverables except when used in direct citation.

1 Scope

The present document is one of the parts of the specification of the DECT-2020 New Radio (NR).

The present document specifies the Physical layer and interaction between PHY and MAC layer.

2 References

2.1 Normative references

References are either specific (identified by date of publication and/or edition number or version number) or non-specific. For specific references, only the cited version applies. For non-specific references, the latest version of the referenced document (including any amendments) applies.

Referenced documents which are not found to be publicly available in the expected location might be found at <https://docbox.etsi.org/Reference>.

NOTE: While any hyperlinks included in this clause were valid at the time of publication, ETSI cannot guarantee their long term validity.

The following referenced documents are necessary for the application of the present document.

- [1] ETSI TS 103 636-1: "DECT-2020 New Radio (NR); Part 1: Overview; Release 1".
- [2] ETSI TS 103 636-2: "DECT-2020 New Radio (NR); Part 2: Radio reception and transmission requirements; Release 1".
- [3] ETSI TS 103 636-4: "DECT-2020 New Radio (NR); Part 4: MAC layer; Release 1".

2.2 Informative references

References are either specific (identified by date of publication and/or edition number or version number) or non-specific. For specific references, only the cited version applies. For non-specific references, the latest version of the referenced document (including any amendments) applies.

NOTE: While any hyperlinks included in this clause were valid at the time of publication, ETSI cannot guarantee their long term validity.

The following referenced documents are not necessary for the application of the present document but they assist the user with regard to a particular subject area.

Not applicable.

3 Definition of terms, symbols and abbreviations

3.1 Terms

Void.

3.2 Symbols

For the purposes of the present document, the following symbols apply:

- \forall Mathematical notation for "for all"
- \wedge Mathematical notation for "and"

$\lfloor x \rfloor$	Mathematical notation for "floor of x" i.e. rounding towards zero
$\lceil x \rceil$	Mathematical notation for "ceiling of x" i.e. rounding towards infinity
β	Fourier transform scaling factor
μ	Subcarrier scaling factor
Δ_f^μ	Subcarrier spacing for given subcarrier scaling factor
$f_s^{\mu,\beta}$	Sample frequency
k_{OCC}^β	Occupied subcarriers for given transform scaling factor
$B_{DFT}^{\mu,\beta}$	Nominal bandwidth
$B_{TX}^{\mu,\beta}$	Transmission bandwidth
GI^μ	Guard interval for given subcarrier scaling factor
M_{symb}^{stream}	Number of modulated symbols in a spatial stream
M_{symb}	Number of modulated symbols
N_{CP}^β	Cyclic Prefix size for given transform scaling factor
N_{DFT}^β	Discrete Fourier Transform size for given Fourier transform scaling factor
N_{OCC}^β	Number of occupied subcarriers for given Fourier transform scaling factor
N_{symb}^{SLOT}	Number OFDM symbols in a slot
$N_{subslot}^{SLOT}$	Number of subslots in a slot
N_{slot}^{FRAME}	Number of slots in a frame
N_{symb}^{PACKET}	Number of OFDM symbols in a transmission packet
N_{TX}	Number of transmission antennas
N_{TX}^{eff}	Effective number of transmission antennas
N_{TS}	Number of transmit streams
N_{SS}	Number of spatial streams
N_{bps}	Number of bits per symbol for given modulation
T_{frame}	Duration of a frame
T_{slot}	Duration of a slot
$T_s^{\mu,\beta}$	Sample time interval
T_{symb}^μ	Duration of OFDM symbol for given subcarrier scaling factor

3.3 Abbreviations

For the purposes of the present document, the abbreviations given in ETSI TS 103 636-1 [1] and the following apply:

NOTE: An abbreviation defined in the present document takes precedence over the definition of the same abbreviation, if any, in ETSI TS 103 636-1 [1].

ARQ	Automatic Repeat Request
BPSK	Binary Phase Shift Keying
CP	Cyclic Prefix
CRC	Cyclic Redundancy Check
DC	Zero or DC Subcarrier
DECT	Digital Enhanced Cordless Telecommunications
DF	Data Field
DFT	Discrete Fourier Transform
DRS	Demodulation Reference Signal
FDMA	Frequency Division Multiple Access
GF	Galois Field
GI	Guard Interval
HARQ	Hybrid ARQ
MAC	Medium Access Layer
OFDM	Orthogonal Frequency Division Multiplexing
PCC	Physical Control Channel
PCCC	Parallel Concatenated Convolutional Code
PDC	Physical Data Channel
PDU	Protocol Data Unit
PHY	Physical layer
QAM	Quadrature Amplitude Modulation

QPSK	Quadrature Phase Shift Keying
RD	Radio Device
SAP	Service Access Point
STF	Synchronization Training Field
SS	Spatial Stream
TDD	Time Division Duplex
TDMA	Time Division Multiple Access
TS	Transmit Stream
TX	Transmission

4 Physical layer principles

4.1 General description of Physical layer

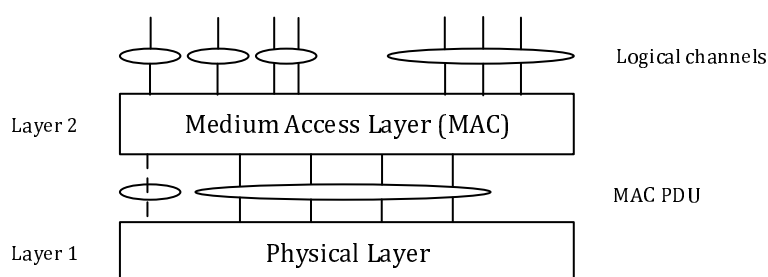

Figure 4.1-1: Radio interface protocol architecture around the Physical layer

Figure 4.1-1 shows the DECT-2020 radio interface protocol architecture around the Physical layer (PHY). The physical layer interfaces the Medium Access Control (MAC) layer. The circles between different layer/sub-layers indicate Service Access Points (SAPs). The physical layer offers Physical Control Channel (PCC) and Physical Data Channel (PDC) to transmit MAC PDU(s). Different physical channels are characterized by how the information is transferred over the radio interface within single transmission packet.

The physical layer performs the following functions in order to provide the data transport service:

- Error detection on the physical channels and indication to higher layers
- FEC encoding/decoding of the physical channels
- Hybrid ARQ soft-combining
- Rate matching of the coded physical channel data to physical channels
- Mapping of the coded physical channel data onto physical channels
- Modulation and demodulation of physical channels
- Frequency and time synchronization
- Radio characteristics measurements and indication to higher layers
- Multiple Input Multiple Output (MIMO) antenna processing
- Transmit Diversity (TX diversity)
- Beamforming

The physical channels defined are:

- the Physical Control Channel (PCC);
- the Physical Data Channel (PDC).

The modulation schemes supported are:

- BPSK;
- QPSK;
- 16-QAM;
- 64-QAM;
- 256-QAM; and
- 1024-QAM.

The channel coding scheme for transport blocks in all physical channels is Turbo Coding with a coding rate of $R=1/3$, two 8-state constituent encoders and a turbo code internal interleaver. Trellis termination is used for the turbo coding. Before the turbo coding, transport blocks are segmented into byte aligned segments with a maximum codeblock size. Error detection is supported by the use of 16 or 24 bit CRC as specified for a given physical channel.

4.2 Multiple access

The multiple access scheme for the DECT-2020 physical layer is based on Time Division Duplex (TDD) combined with Frequency Division Multiple Access (FDMA) and Time Division Multiple Access (TDMA). The physical layer operates with non-overlapping channels in frequency domain and non-overlapping transmission slots in time domain. Radio channel spacing is defined in ETSI TS 103 636-2 [2].

The modulation within the transmitted packets is Orthogonal Frequency Division Multiplexing (OFDM) with a Cyclic Prefix (CP).

Both frame duration (10 ms) and slot duration (0,41667 ms) ensures coexistence with legacy DECT systems.

4.3 Numerologies

In the present document, unless otherwise noted, the size of various fields in the time domain are expressed in terms of basic parameters. Subcarrier spacing is defined by the subcarrier scaling factor μ , resulting either in 27 kHz, 54 kHz, 108 kHz or 216 kHz OFDM subcarriers spacing Δ_f^μ . In addition, the Fourier transform scaling factor β can be set to allow different transmission bandwidths for each configuration of the subcarrier spacing. The numerologies listed in table 4.3-1 support multiple throughput and latency configurations for the network. In the table $B_{DFT}^{\mu,\beta}$ denotes the nominal bandwidth, $B_{TX}^{\mu,\beta}$ denotes the transmission bandwidth, $T_s^{\mu,\beta}$ denotes the critical sample rate, N_{DFT}^β the Fourier transform size, N_{CP}^β denotes the cyclic prefix size in samples and N_{OCC}^β denotes the number of occupied subcarriers.

Table 4.3-1: Supported transmission numerologies

	β	$B_{DFT}^{\mu,\beta}$ [kHz]	$T_s^{\mu,\beta}$	N_{DFT}^β	N_{CP}^β	N_{OCC}^β	$B_{TX}^{\mu,\beta}$ [kHz]	
μ Δ_f^μ [kHz] T_{sym}^μ [us] $N_{SLOT,\mu}^{SLOT,\mu}$ N_{sym} $N_{SLOT,\mu}^{SLOT,\mu}$ $N_{subslot}$ GI^μ [us]	1	1 728	5,7870E-07	64	8	56	1 512	
	27	3 456	2,8935E-07	128	16	112	3 024	
	41,667	4	6 912	1,4468E-07	256	32	224	6 048
	10	8	13 824	7,2338E-08	512	64	448	12 096
	2	12	20 736	4,8225E-08	768	96	672	18 144
	18,52	16	27 648	3,6169E-08	1 024	128	896	24 192
μ Δ_f^μ [kHz] T_{sym}^μ [us] $N_{SLOT,\mu}^{SLOT,\mu}$ N_{sym} $N_{SLOT,\mu}^{SLOT,\mu}$ $N_{subslot}$ GI^μ [us]	2	3 456	2,8935E-07	64	8	56	3 024	
	54	6 912	1,4468E-07	128	16	112	6 048	
	20,833	4	13 824	7,2338E-08	256	32	224	12 096
	20	8	27 648	3,6169E-08	512	64	448	24 192
	4	12	41 472	2,4113E-08	768	96	672	36 288
	20,83	16	55 296	1,8084E-08	1 024	128	896	48 384

μ	β	$B_{DFT}^{\mu,\beta}$ [kHz]	$T_s^{\mu,\beta}$	N_{DFT}^{β}	N_{CP}^{β}	N_{OCC}^{β}	$B_{TX}^{\mu,\beta}$ [kHz]
μ Δ_f^{μ} [kHz] T_{sym}^{μ} [us] $N_{sym}^{SLOT,\mu}$ $N_{subslot}^{SLOT,\mu}$ GI^{μ} [us]	4	6 912	1,4468E-07	64	8	56	6 048
	108	13 824	7,2338E-08	128	16	112	12 096
	10,417	27 648	3,6169E-08	256	32	224	24 192
	40	55 296	1,8084E-08	512	64	448	48 384
	8	82 944	1,2056E-08	768	96	672	72 576
	16	110 592	9,0422E-09	1 024	128	896	96 768
μ Δ_f^{μ} [kHz] T_{sym}^{μ} [us] $N_{sym}^{SLOT,\mu}$ $N_{subslot}^{SLOT,\mu}$ GI^{μ} [us]	8	13 824	7,2338E-08	64	8	56	12 096
	216	27 648	3,6169E-08	128	16	112	24 192
	5,208	55 296	1,8084E-08	256	32	224	48 384
	80	110 592	9,0422E-09	512	64	448	96 768
	16	165 888	6,0282E-09	768	96	672	145 152
	10,42	221 184	4,5211E-09	1 024	128	896	193 536

4.4 Frame structure

The radio frame has a duration of $T_{frame} = 10ms$ and consists of $N_{slot}^{FRAME} = 24$ slots with a slot duration of $T_{slot} = 0,41667ms$ as depicted in figure 4.4-1.

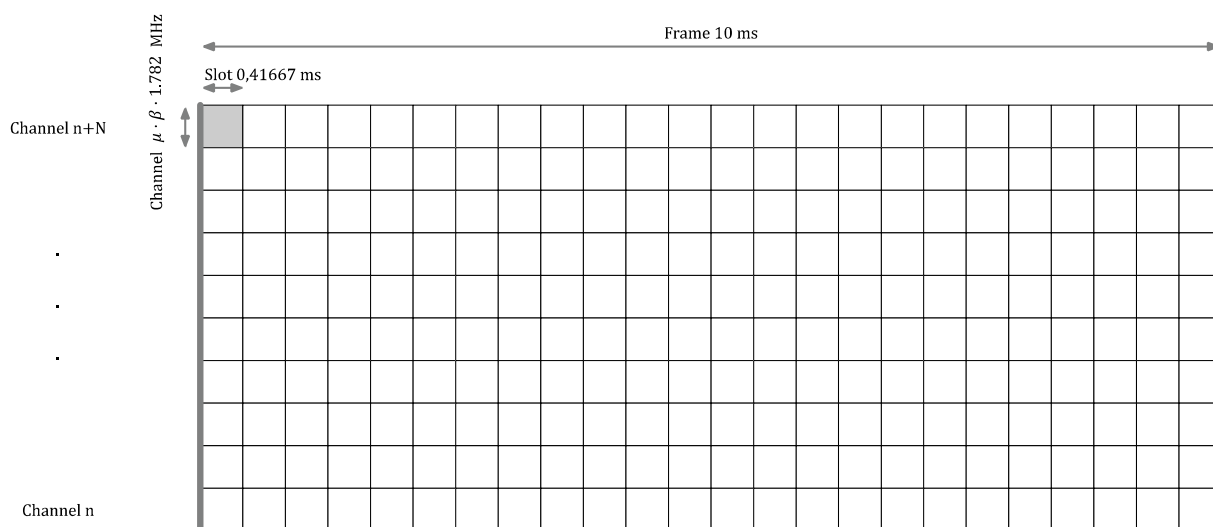

Figure 4.4-1: DECT-2020 frame structure

Each slot consists of $N_{sym}^{SLOT,\mu} = 10, 20, 40$ or 80 OFDM symbols depending on subcarrier scaling factor μ . Slot is further divided into $N_{subslot}^{SLOT,\mu}$ subslots according to the table 4.3-1 for each subcarrier scaling μ . Packet transmission duration is integer multiple of subslots.

Basic channel width is 1,728 MHz. Multiple adjacent basic channels can be aggregated with β and μ to form a wider transmission bandwidth ranging from 1,728 MHz to 221,184 MHz. Channel raster and numbering is specified in ETSI TS 103 636-2 [2].

4.5 Physical resources

Physical resources are mapped to frequency domain OFDM symbol $(s, k, l)_{\beta}$, where s may denote either transmit stream or spatial stream index, k denotes the subcarrier index and l denotes the OFDM symbol position in the time domain relative to the start of the transmission packet as depicted in figure 4.5-1. The occupied subcarriers indices are:

$$k_{OCC}^{\beta} = \left[-\frac{N_{OCC}^{\beta}}{2}, \dots, -1, 1, \dots, \frac{N_{OCC}^{\beta}}{2} \right]$$

The remaining subcarriers are the guard bands and the zero carrier (or DC carrier) which are not used for data transmission. Example of resource mappings are depicted in figures 4.5-2 and 4.5-3.

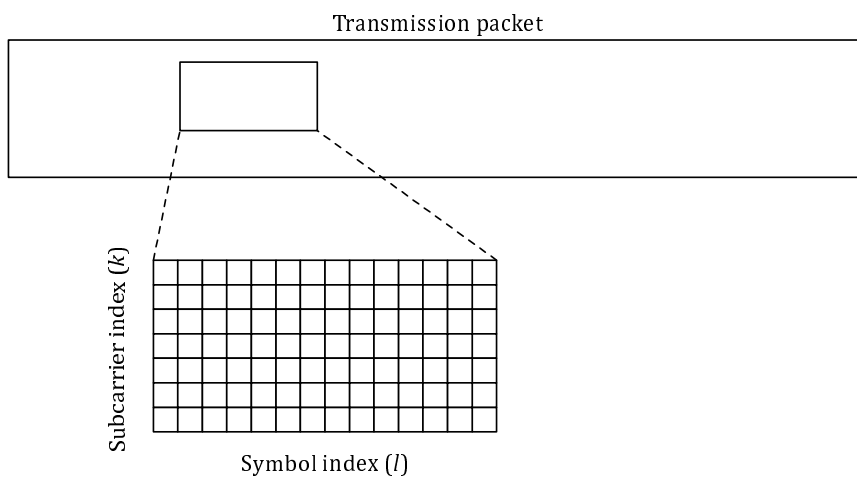

Figure 4.5-1: Resource grid and indexing

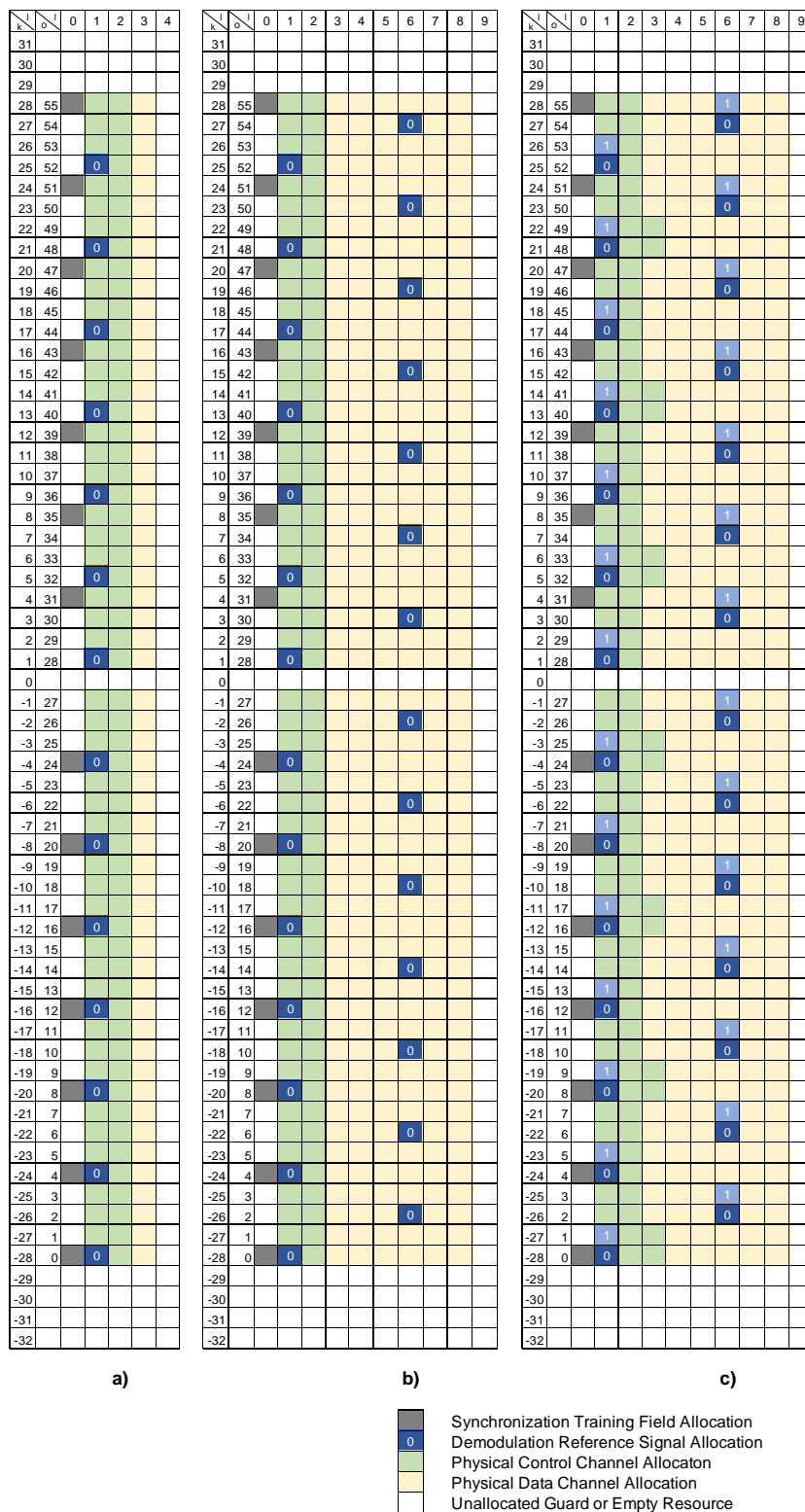

Figure 4.5-2: Resource mapping for $(\mu, \beta) = (*, 1)$
a) Transmission from single effective antenna of one subslot duration
b) Transmission from single effective antenna of two subslots duration
c) Transmission from two effective antennas of two subslots duration

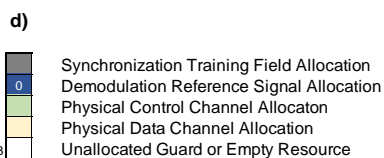
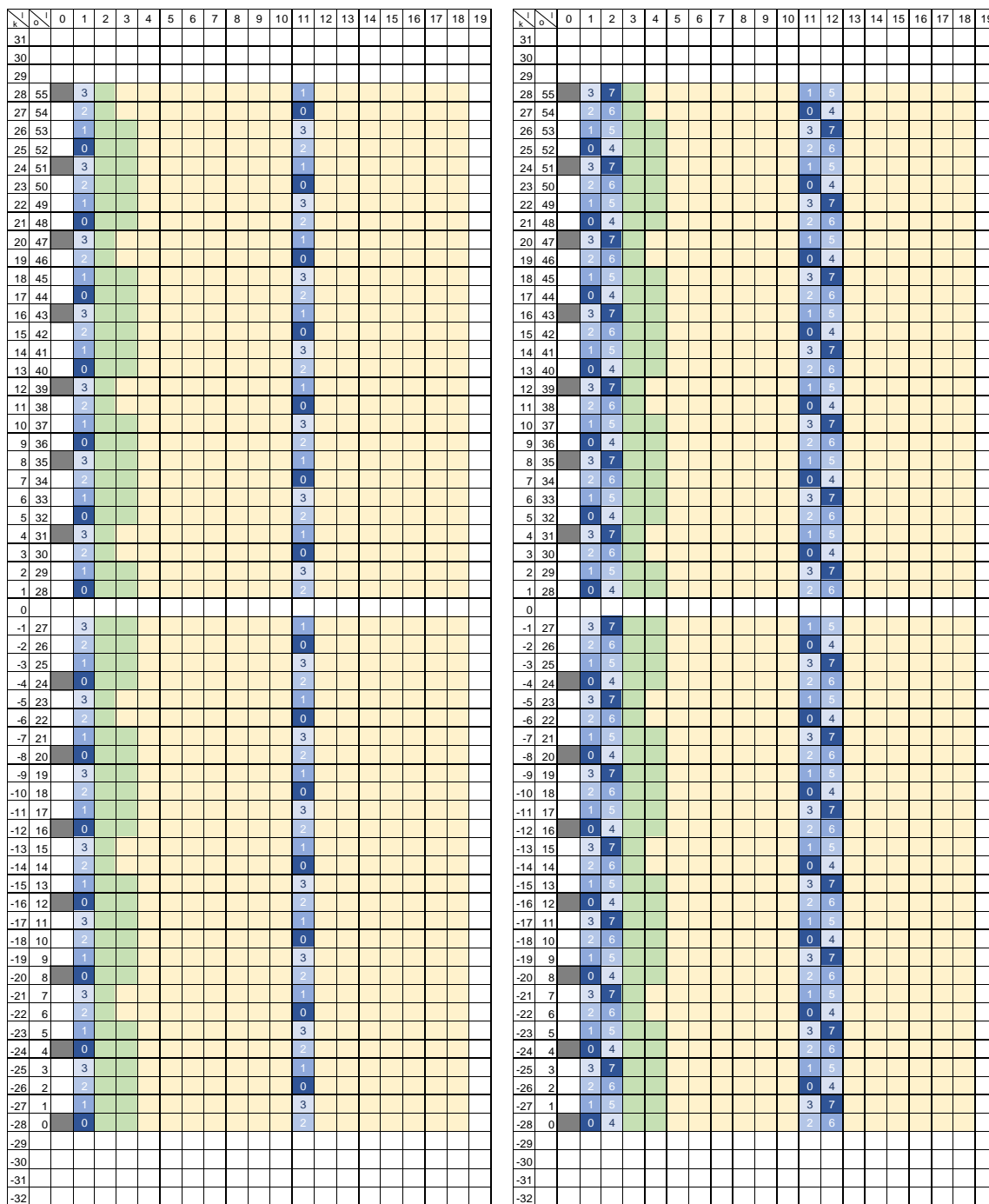

Figure 4.5-3: Resource mapping for $(\mu, \beta) = (*, 1)$
d) Transmission from four effective antennas of four subslots duration
e) Transmission from eight effective antennas of four subslots duration

5 Physical layer transmissions

5.1 Transmission packet structure

DECT-2020 transmission packet consists of Synchronization Training Field (STF), Data Field (DF) and Guard Interval (GI) as depicted in figures 5.1-1, 5.1-2 and 5.1-3. OFDM symbol length T_{symb}^μ is dependent on the subcarrier scaling factor μ as shown in table 4.3-1. STF transmission starts at transmission allocation boundary. SFT is purposefully constructed to create time domain repetitive pattern for receiver gain, timing and frequency acquisition. DF carries Demodulation Reference Signal (DRS), Physical Control Channel (PCC) and Physical Data Channel (PDC). GI in the end of the packet allows transmission-reception and reception-transmission turnaround and to avoid overlapping transmissions from adjacent TDMA timeslots.

Transmission packet length in OFDM symbols is:

$$\begin{aligned} \text{if } PacketLengthType = 0 &\Rightarrow N_{symb}^{PACKET} = PacketLength * N_{symb}^{SLOT,\mu} / N_{subslot}^{SLOT,\mu} \\ \text{if } PacketLengthType = 1 &\Rightarrow N_{symb}^{PACKET} = PacketLength * N_{symb}^{SLOT,\mu} \end{aligned}$$

depending whether *PacketLengthType* in Physical Header ETSI TS 103 636-4 [3] clause 6.2.1 indicates that the packet length is specified in terms of slots or subslots. The transmission packet length contains GI duration.

For $N_{TX}^{eff} \geq 4$ transmission length should be at least three subslots (15 OFDM symbols) to accomodate second set of demodulation reference signals for time variant channel and frequency error estimation.

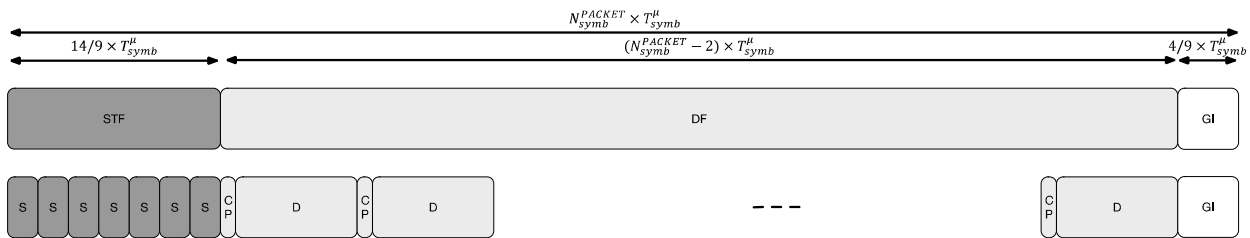

Figure 5.1-1: Packet structure for $\mu = \{1\}$

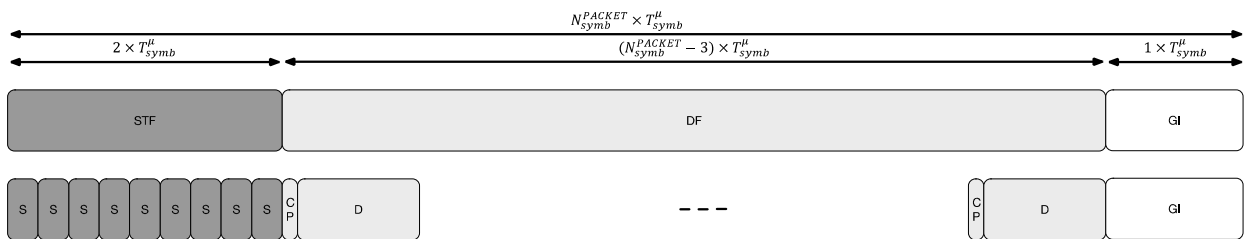

Figure 5.1-2: Packet structure for $\mu = \{2, 4\}$

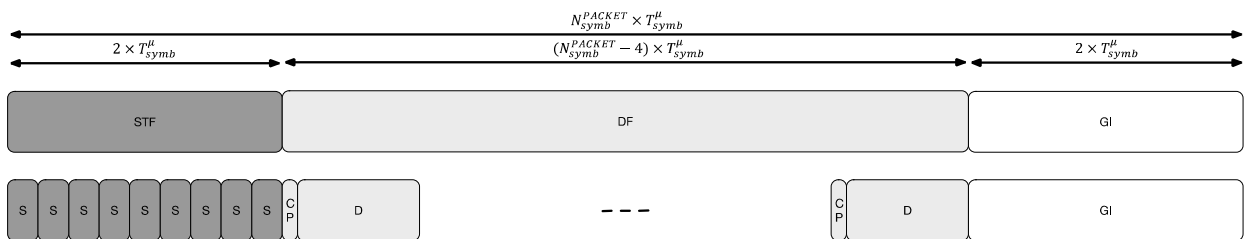

Figure 5.1-3: Packet structure for $\mu = \{8\}$

NOTE: For the highest subcarrier scaling the 4-bit packet length specifier allows packet length scaling from 5 to 80 OFDM symbols when packet length is specified in subslots, and up to 1 280 OFDM symbols when length is specified in slots.

5.2 Physical resource mapping

5.2.1 Guard Interval (GI)

GI in the end of the packet allows transmission-reception and reception-transmission turnaround and to avoid overlapping transmissions from adjacent timeslots. Guard intervals are of length $GI^{\mu=1} = \frac{4}{9} \cdot T_{symbol}^{\mu}$, $GI^{\mu=\{2,4\}} = 1 \cdot T_{symbol}^{\mu}$ and $GI^{\mu=8} = 2 \cdot T_{symbol}^{\mu}$ for subcarrier scaling factors $\mu = \{1,2,4,8\}$, respectively. Guard interval duration in μs is listed in table 4.3-1 for each subcarrier scaling.

5.2.2 Synchronization Training Field (STF)

Synchronization training signal is mapped into frequency domain subcarriers:

$$(t, k_i, l) = (0, k_{OCC}^{\beta} [i \cdot 4], 0), \forall i = 0, \dots, \frac{N_{OCC}^{\beta}}{8} - 1$$

and

$$(t, k_i, l) = \left(0, k_{OCC}^{\beta} \left[\frac{N_{OCC}^{\beta}}{2} + 3 + \left(i - \frac{N_{OCC}^{\beta}}{8}\right) \cdot 4 \right], 0 \right), \forall i = \frac{N_{OCC}^{\beta}}{8}, \dots, \frac{N_{OCC}^{\beta}}{4} - 1$$

Thus, synchronization training is always in transmit stream $t = 0$ and in OFDM symbol $l = 0$ on every fourth subcarrier starting from the lowest occupied negative subcarrier but excluding the DC carrier.

EXAMPLE: The occupied STF subcarriers for DFT size 64 are [-28, -24, -20, -16, -12, -8, -4, 4, 8, 12, 16, 20, 24, 28] as depicted in figure 4.5-2.

Synchronization training data symbols are defined as:

$$y_i^{STF,(0)} = y^{(0),\beta} \left[\left(i + 2 \cdot \log_2(N_{TX}^{eff}) \right) \bmod \frac{N_{OCC}}{4} \right], \forall i = 0, \dots, \frac{N_{OCC}}{4} - 1$$

where N_{TX}^{eff} is the effective number of transmit antennas, which equals to the number of transmit streams $N_{TX}^{eff} = N_{TS}$. The STF base sequences are defined as:

$$y^{(0),\beta=1} = \{0 - 1j, 0 - 1j, -1 + 0j, -1 + 0j, 0 + 1j, 0 - 1j, 0 + 1j, 0 - 1j, 0 - 1j, 0 + 1j, 0 + 1j, -1 - 0j, 0 - 1j, -1 + 0j\}$$

$$y^{(0),\beta=2} = \{1, -1, 1, 1, 1, -1, 1, 1, 1, 1, -1, -1, 1, -1, 1, 1, 1, -1, 1, 1, -1, 1, 1, 1, 1, -1, 1, -1\}$$

$$y^{(0),\beta=4} = \{y^{(0),\beta=2}, y^{(0),\beta=2}\}$$

$$y^{(0),\beta=8} = \{y^{(0),\beta=4}, y^{(0),\beta=4}\}$$

$$y^{(0),\beta=12} = \{y^{(0),\beta=4}, y^{(0),\beta=4}, y^{(0),\beta=4}\}$$

$$y^{(0),\beta=16} = \{y^{(0),\beta=8}, y^{(0),\beta=8}\}$$

NOTE: Single effective transmit antenna is signalled with base sequence $y^{(0),\beta}$ transmitted as it is, two effective transmit antennas transmit the base sequence as a two steps, four effective transmit antennas transmit the base sequence as four steps, and eight effective transmit antennas transmit the base sequence as six steps cyclically rotated versions.

5.2.3 Demodulation Reference Signal (DRS)

Demodulation reference signals are allocated to the transmit streams according to the number of transmit streams N_{TS} . DRS is transmitted on the resources:

$$(t, k_i, l) = (t, k_{OCC}^\beta [i \cdot 4 + (t + (n \bmod 2) \cdot 2) \bmod 4], 1 + \lfloor t/4 \rfloor + n \cdot N_{step}),$$

$$\forall i = 0, \dots, \frac{N_{OCC}^\beta}{4} - 1, n = 0, \dots, \left\lfloor \frac{N_{PACKET}^{Symb}}{N_{step}} \right\rfloor - 1$$

$$N_{step} = \begin{cases} 5, & \text{if } N_{TX}^{eff} \leq 2 \\ 10, & \text{if } N_{TX}^{eff} \geq 4 \end{cases}$$

where t is the transmit stream index.

EXAMPLE: Thus the pilot carriers for DFT size of 64 and for $t = 0$ are [-28, -24, -20, -16, -12, -8, -4, 1, 5, 9, 13, 17, 21, 25], for OFDM symbols $1 + n \cdot N_{step} \forall n \bmod 2 = 0$ and [-26, -22, -18, -14, -10, -6, -2, 3, 7, 11, 15, 19, 23, 27] for $1 + n \cdot N_{step} \forall n \bmod 2 = 1$ as depicted in figure 4.5-2.

Signal transmitted on DRS subcarrier k_i is:

$$y_i^{DRS,(t)} = \begin{cases} y^\beta [4 \cdot i + t \bmod 4] \forall i = 0, \dots, N_{DFT}^\beta / 4 - 1 \wedge t \leq 4 \\ -y^\beta [4 \cdot i + t \bmod 4] \forall i = 0, \dots, N_{DFT}^\beta / 4 - 1 \wedge t > 4 \end{cases}$$

where the base sequences are defined as

$$y^{\beta=1} = \{1, 1, 1, 1, -1, 1, 1, -1, -1, 1, 1, 1, -1, 1, -1, 1, 1, -1, 1, -1, 1, 1, 1, 1, -1, 1, -1, 1, -1, 1, 1, 1, -1, 1, -1, 1, 1, 1, 1, -1, 1, -1, -1, 1, 1, -1, -1, -1, -1, 1, 1, -1, -1, -1, -1, 1, 1, 1, -1, 1, 1, -1, -1, 1, -1, -1, -1\}$$

$$y^{\beta=2} = \{y^{\beta=1}, y^{\beta=1}\}$$

$$y^{\beta=4} = \{y^{\beta=2}, y^{\beta=2}\}$$

$$y^{\beta=8} = \{y^{\beta=4}, y^{\beta=4}\}$$

$$y^{\beta=12} = \{y^{\beta=4}, y^{\beta=4}, y^{\beta=4}\}$$

$$y^{\beta=16} = \{y^{\beta=8}, y^{\beta=8}\}$$

5.2.4 Physical Control Channel (PCC)

PCC is mapped to spatial stream 0 to the $N_{subc}^{PCC} = 98$ subcarriers starting from OFDM symbol $l = 1$ and to the subcarriers which are not already occupied by DRS in any transmit stream. The procedure for subcarrier allocation for PCC is defined with steps:

- 1) Start from OFDM symbol $l = 1$ and set $N_{subc}^{unalloc} = 98$.
- 2) Starting from the lowest subcarrier of the OFDM symbol l , select the subcarriers which are not allocated for DRS and denote them by $k_{(0,l)}, k_{(1,l)}, \dots, k_{(U-1,l)}$, where U is the number of such unoccupied carriers.
- 3) If $U < N_{subc}^{unalloc}$ go to 4) else go to 5) to spread the remaining allocation as widely as possible across the transmission bandwidth.
- 4) Allocate all the available subcarriers in symbol l to PCC:
 - a) Add all subcarriers $k_{(0,l)}, k_{(1,l)}, \dots, k_{(U-1,l)}$ to the set of subcarriers k_l^{PCC} allocated to PCC.
 - b) Proceed to the next OFDM symbol by setting $l = l + 1$ and subtracting already allocated subcarriers $N_{subc}^{unalloc} = N_{subc}^{unalloc} - U$.
 - c) Jump to 2).

- 5) Assign $R^{PCC} = 7$ to be the number of rows of the matrix. The rows of the matrix are numbered 0, 1, 2, ..., $R^{PCC} - 1$ from top to bottom.
- 6) Determine the number of columns of the matrix C^{PCC} by:

$$C^{PCC} = U/R^{PCC}$$

The columns of rectangular matrix are numbered 0, 1, 2, ..., $C^{PCC} - 1$ from left to right.

- 7) Then, the subcarrier indices are written into the $(R^{PCC} \times C^{PCC})$ matrix row by row starting with bit $k_{(0,l)}$ in column 0 of row 0:

$$\begin{bmatrix} k_{(0,l)} & k_{(1,l)} & k_{(2,l)} & \cdots & k_{(C^{PCC}-1,l)} \\ k_{(C^{PCC},l)} & k_{(C^{PCC}+1,l)} & k_{(C^{PCC}+2,l)} & \cdots & k_{(2C^{PCC},l)} \\ \vdots & \vdots & \vdots & \ddots & \vdots \\ k_{((R^{PCC}-1) \times C^{PCC},l)} & k_{((R^{PCC}-1) \times C^{PCC}+1,l)} & k_{((R^{PCC}-1) \times C^{PCC}+2,l)} & \cdots & k_{(R^{PCC} \times C^{PCC}-1,l)} \end{bmatrix}$$

- 8) The $N_{subc}^{unalloc}$ subcarriers are read from the matrix column by column starting from row 0 of column 0 to the set of PCC subcarriers k_l^{PCC} . Thus, allocation order is $k_{(0,l)}, k_{(C^{PCC},l)}, \dots, k_{((R^{PCC}-1) \times C^{PCC},l)}, k_{(1,l)}, k_{(C^{PCC}+1,l)}, \dots$, until all N_{subc}^{PCC} are allocated.

EXAMPLE: Examples of subcarrier allocations for PCC are depicted in figures 4.5-2 and 4.5-3.

Modulated data is mapped to the set of subcarriers k^{PCC} starting from lowest OFDM symbol index l and from lowest subcarrier index available for that OFDM symbol, filling the subcarriers first in frequency direction and then proceeding to the next OFDM symbol.

NOTE: Symbol mapping order is independent of allocation order. Thus, the list of allocated subcarriers is used in sorted order from lowest to highest for each OFDM symbol.

5.2.5 Physical Data Channel (PDC)

The remaining subcarriers of DF which are not allocated for DRS in any transmit stream or PCC in spatial stream 0 are allocated for PDC.

The length of DF in OFDM symbols is given by:

$$N_{symp}^{DF} = N_{symp}^{PACKET} - N_{symp}^{GI+STF}$$

where $N_{symp}^{GI+STF} = 2$ for $\mu = \{1\}$, $N_{symp}^{GI+STF} = 3$ for $\mu = \{2, 4\}$ and $N_{symp}^{GI+STF} = 4$ for $\mu = 8$. The number of DRS subcarriers N_{subc}^{DRS} in a packet is given by:

$$N_{subc}^{DRS} = N_{TX}^{eff} \cdot \frac{N_{OCC}^{\beta}}{4} \cdot \left\lfloor \frac{N_{symp}^{PACKET}}{N_{step}} \right\rfloor$$

where:

$$N_{step} = \begin{cases} 5, & \text{if } N_{TX}^{eff} \leq 2 \\ 10, & \text{if } N_{TX}^{eff} \geq 4 \end{cases}$$

The number of PDC subcarriers N_{subc}^{PDC} is then given by:

$$N_{subc}^{PDC} = N_{symp}^{DF} \cdot N_{OCC}^{\beta} - N_{subc}^{DRS} - N_{subc}^{PCC}$$

Modulated data is mapped to the set of subcarriers k^{PDC} starting from lowest OFDM symbol index l and from lowest subcarrier index available for that OFDM symbol, filling the subcarriers first in frequency direction and then proceeding to the next OFDM symbol.

5.3 Transport block size

With number of subcarriers N_{subc}^{PDC} available for transmission transport block size N_{bits}^{TB} is calculated as follows.

Supported Modulation and Coding Schemes (MCS) are defined in table A-1. For a MCS carrying N_{bps} bits per symbol and coding rate R , maximum number of bits which can be carried by the PDC is given by:

$$N_{bits}^{PDC} = \lfloor N_{ss} \cdot N_{subc}^{PDC} \cdot N_{bps} \cdot R \rfloor,$$

where the number of subcarriers available for PDC transmission N_{subc}^{PDC} for given packet size is calculated according to clause 5.2.5 and N_{ss} is the number of parallel spatial streams.

Set the CRC length of the TBS and individual code block segments as:

$$L = 24$$

Set maximum turbo encoder code block size according to the RD class specified in Annex B either to:

$$Z = 2048$$

or:

$$Z = 6144$$

If $N_{bits}^{PDC} \leq 512$, set:

$$M = 8$$

Else if $N_{bits}^{PDC} \leq 1024$, set:

$$M = 16$$

Else if $N_{bits}^{PDC} \leq 2048$, set:

$$M = 32$$

Else

$$M = 64$$

Calculate the largest multiple of M not greater than N_{bits}^{PDC} as:

$$N_M = \left\lfloor \frac{N_{bits}^{PDC}}{M} \right\rfloor \times M$$

If $N_M \leq Z$, set:

$$N_{bits}^{TB} = N_M - L$$

Else transport block will be segmented. Calculate the number of code block segments:

$$C = \left\lceil \frac{N_M - L}{Z} \right\rceil$$

To get the transport block size subtract the transport block CRC length and individual codeblock CRC lengths:

$$N_{bits}^{TB} = N_M - (C + 1) \times L$$

NOTE: With this definition of transport block size the number of filler bits in clause 6.1.3 is always 0.

6 Generic procedures

6.1 Channel coding, rate-matching and interleaving

6.1.1 Overview

Data and control streams from/to MAC layer are encoded/decoded to offer physical layer packet services over the radio transmission link. Channel coding scheme is a combination of error detection, error correction, rate matching and interleaving.

6.1.2 CRC calculation

Denote the input bits to the CRC computation by $a_0, a_1, a_2, a_3, \dots, a_{A-1}$, and the parity bits by $p_0, p_1, p_2, p_3, \dots, p_{L-1}$. A is the size of the input sequence and L is the number of parity bits. The parity bits are generated by one of the following cyclic generator polynomials:

- $g_{\text{CRC24A}}(D) = [D^{24} + D^{23} + D^{18} + D^{17} + D^{14} + D^{11} + D^{10} + D^7 + D^6 + D^5 + D^4 + D^3 + D + 1]$; and
- $g_{\text{CRC24B}}(D) = [D^{24} + D^{23} + D^6 + D^5 + D + 1]$ for a CRC length $L = 24$; and
- $g_{\text{CRC16}}(D) = [D^{16} + D^{12} + D^5 + 1]$ for a CRC length $L = 16$.

The encoding is performed in a systematic form, which means that in GF(2), the polynomial:

$$a_0 D^{A+23} + a_1 D^{A+22} + \dots + a_{A-1} D^{24} + p_0 D^{23} + p_1 D^{22} + \dots + p_{22} D^1 + p_{23}$$

yields a remainder equal to 0 when divided by the corresponding length-24 CRC generator polynomial, $g_{\text{CRC24A}}(D)$ or $g_{\text{CRC24B}}(D)$, the polynomial:

$$a_0 D^{A+15} + a_1 D^{A+14} + \dots + a_{A-1} D^{16} + p_0 D^{15} + p_1 D^{14} + \dots + p_{14} D^1 + p_{15}$$

yields a remainder equal to 0 when divided by $g_{\text{CRC16}}(D)$.

The bits after CRC attachment are denoted by $b_0, b_1, b_2, b_3, \dots, b_{B-1}$, where $B = A + L$. The relation between a_k and b_k is:

$$b_k = a_k \quad \text{for } k = 0, 1, 2, \dots, A-1$$

$$b_k = p_{k-A} \quad \text{for } k = A, A+1, A+2, \dots, A+L-1.$$

6.1.3 Code block segmentation

The input bit sequence to the code block segmentation is denoted by $b_0, b_1, b_2, b_3, \dots, b_{B-1}$, where $B > 0$. If B is larger than the maximum code block size Z , segmentation of the input bit sequence is performed, and an additional CRC sequence of $L = 24$ bits is attached to each code block. The maximum code block size is:

- $Z = 2048$ or 6144 as defined in annex B for each Radio Device Class.

If the number of filler bits F calculated below is not 0, filler bits are added to the beginning of the first block.

Note that if $B < 40$, filler bits are added to the beginning of the code block.

The filler bits shall be set to $\langle \text{NULL} \rangle$ at the input to the encoder.

Total number of code blocks C is determined by:

$$\text{if } B \leq Z$$

$$L = 0$$

$$\text{Number of code blocks: } C = 1$$

$$B' = B$$

else

$$L = 24$$

Number of code blocks: $C = \lceil B/(Z - L) \rceil$.

$$B' = B + C \cdot L$$

end if

The bits output from code block segmentation, for $C \neq 0$, are denoted by $c_{r0}, c_{r1}, c_{r2}, c_{r3}, \dots, c_{r(K_r-1)}$, where r is the code block number, and K_r is the number of bits for the code block number r .

Number of bits in each code block (applicable for $C \neq 0$ only):

First segmentation size: K_+ = minimum K in table 6.1.4.2.3-1 such that $C \cdot K \geq B'$

if $C = 1$

the number of code blocks with length K_+ is $C_+ = 1, K_- = 0, C_- = 0$

else if $C > 1$

Second segmentation size: K_- = maximum K in table 6.1.4.2.3-1 such that $K < K_+$

$$\Delta_K = K_+ - K_-$$

$$\text{Number of segments of size } K_-: C_- = \left\lfloor \frac{C \cdot K_+ - B'}{\Delta_K} \right\rfloor$$

$$\text{Number of segments of size } K_+: C_+ = C - C_-$$

end if

Number of filler bits: $F = C_+ \cdot K_+ + C_- \cdot K_- - B'$

for $k = 0$ to $F-1$ -- Insertion of filler bits

$$c_{0k} = \langle \text{NULL} \rangle$$

end for

$k = F$

$s = 0$

for $r = 0$ to $C-1$

if $r < C_-$

$$K_r = K_-$$

else

$$K_r = K_+$$

end if

while $k < K_r - L$

$$c_{rk} = b_s$$

$$k = k + 1$$

$$s = s + 1$$

end while

if $C > 1$

The sequence $c_{r0}, c_{r1}, c_{r2}, c_{r3}, \dots, c_{r(K_r-L-1)}$ is used to calculate the CRC parity bits $p_{r0}, p_{r1}, p_{r2}, \dots, p_{r(L-1)}$ according to clause 6.1.2 with the generator polynomial $g_{\text{CRC24B}}(D)$. For CRC calculation it is assumed that filler bits, if present, have the value 0.

while $k < K_r$

$$c_{rk} = p_{r(k+L-K_r)}$$

$$k = k + 1$$

end while

end if

$$k = 0$$

end for

6.1.4 Channel coding

6.1.4.1 Introduction

The bit sequence input for a given code block to channel coding is denoted by $c_0, c_1, c_2, c_3, \dots, c_{K-1}$, where K is the number of bits to encode. After encoding the bits are denoted by $d_0^{(i)}, d_1^{(i)}, d_2^{(i)}, d_3^{(i)}, \dots, d_{D-1}^{(i)}$, where D is the number of encoded bits per output stream and i indexes the encoder output stream. The relation between c_k and $d_k^{(i)}$ and between K and D is dependent on the channel coding scheme.

6.1.4.2 Turbo coding

6.1.4.2.1 Turbo encoder

The scheme of turbo encoder is a Parallel Concatenated Convolutional Code (PCCC) with two 8-state constituent encoders and one turbo code internal interleaver. The coding rate of turbo encoder is 1/3. The structure of turbo encoder is illustrated in figure 6.1.4.2.1-1.

The transfer function of the 8-state constituent code for the PCCC is:

$$G(D) = \left[1, \frac{g_1(D)}{g_0(D)} \right],$$

where:

$$g_0(D) = 1 + D^2 + D^3,$$

$$g_1(D) = 1 + D + D^3.$$

The initial value of the shift registers of the 8-state constituent encoders shall be all zeros when starting to encode the input bits.

The output from the turbo encoder is:

$$d_k^{(0)} = x_k$$

$$d_k^{(1)} = z_k$$

$$d_k^{(2)} = z'_k$$

for $k = 0, 1, 2, \dots, K - 1$.

If the code block to be encoded is the 0-th code block and the number of filler bits is greater than zero, i.e. $F > 0$, then the encoder shall set $c_k = 0, k = 0, \dots, (F-1)$ at its input and shall set $d_k^{(0)} = \langle NULL \rangle, k = 0, \dots, (F-1)$ and $d_k^{(1)} = \langle NULL \rangle, k = 0, \dots, (F-1)$ at its output.

The bits input to the turbo encoder are denoted by $c_0, c_1, c_2, c_3, \dots, c_{K-1}$, and the bits output from the first and second 8-state constituent encoders are denoted by $z_0, z_1, z_2, z_3, \dots, z_{K-1}$ and $z'_0, z'_1, z'_2, z'_3, \dots, z'_{K-1}$, respectively. The bits output from the turbo code internal interleaver are denoted by $c'_0, c'_1, \dots, c'_{K-1}$, and these bits are to be the input to the second 8-state constituent encoder.

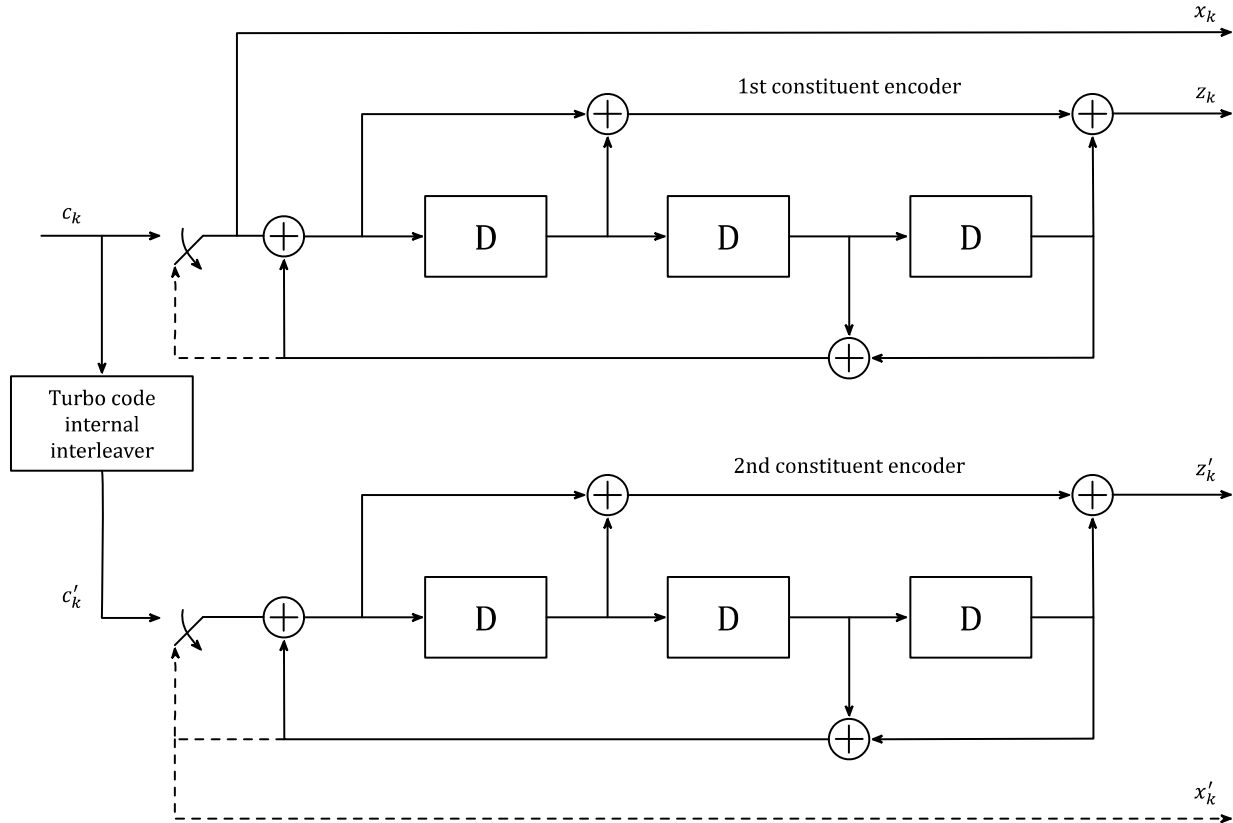

Figure 6.1.4.2.1-1: Structure of rate 1/3 turbo encoder (dotted lines apply for trellis termination only)

6.1.4.2.2 Trellis termination for turbo encoder

Trellis termination is performed by taking the tail bits from the shift register feedback after all information bits are encoded. Tail bits are padded after the encoding of information bits.

The first three tail bits shall be used to terminate the first constituent encoder (upper switch of figure 6.1.4.2.1-1 in lower position) while the second constituent encoder is disabled. The last three tail bits shall be used to terminate the second constituent encoder (lower switch of figure 6.1.4.2.1-1 in lower position) while the first constituent encoder is disabled.

The transmitted bits for trellis termination shall then be:

$$d_K^{(0)} = x_K, d_{K+1}^{(0)} = z_{K+1}, d_{K+2}^{(0)} = x'_K, d_{K+3}^{(0)} = z'_{K+1}$$

$$d_K^{(1)} = z_K, d_{K+1}^{(1)} = x_{K+2}, d_{K+2}^{(1)} = z'_K, d_{K+3}^{(1)} = x'_{K+2}$$

$$d_K^{(2)} = x_{K+1}, d_{K+1}^{(2)} = z_{K+2}, d_{K+2}^{(2)} = x'_{K+1}, d_{K+3}^{(2)} = z'_{K+2}$$

6.1.4.2.3 Turbo code internal interleaver

The bits input to the turbo code internal interleaver are denoted by c_0, c_1, \dots, c_{K-1} , where K is the number of input bits. The bits output from the turbo code internal interleaver are denoted by $c'_0, c'_1, \dots, c'_{K-1}$.

The relationship between the input and output bits is as follows:

$$c'_i = c_{\Pi(i)}, i = 0, 1, \dots, (K-1), i=0, 1, \dots, (K-1)$$

where the relationship between the output index i and the input index $\Pi(i)$ satisfies the following quadratic form:

$$\Pi(i) = (f_1 \cdot i + f_2 \cdot i^2) \bmod K$$

The parameters f_1 and f_2 depend on the block size K and are summarized in table 6.1.4.2.3-1.

Table 6.1.4.2.3-1: Turbo code internal interleaver parameters

<i>i</i>	<i>K</i>	<i>f</i> ₁	<i>f</i> ₂	<i>i</i>	<i>K</i>	<i>f</i> ₁	<i>f</i> ₂	<i>i</i>	<i>K</i>	<i>f</i> ₁	<i>f</i> ₂	<i>i</i>	<i>K</i>	<i>f</i> ₁	<i>f</i> ₂
1	40	3	10	48	416	25	52	95	1 120	67	140	142	3 200	111	240
2	48	7	12	49	424	51	106	96	1 152	35	72	143	3 264	443	204
3	56	19	42	50	432	47	72	97	1 184	19	74	144	3 328	51	104
4	64	7	16	51	440	91	110	98	1 216	39	76	145	3 392	51	212
5	72	7	18	52	448	29	168	99	1 248	19	78	146	3 456	451	192
6	80	11	20	53	456	29	114	100	1 280	199	240	147	3 520	257	220
7	88	5	22	54	464	247	58	101	1 312	21	82	148	3 584	57	336
8	96	11	24	55	472	29	118	102	1 344	211	252	149	3 648	313	228
9	104	7	26	56	480	89	180	103	1 376	21	86	150	3 712	271	232
10	112	41	84	57	488	91	122	104	1 408	43	88	151	3 776	179	236
11	120	103	90	58	496	157	62	105	1 440	149	60	152	3 840	331	120
12	128	15	32	59	504	55	84	106	1 472	45	92	153	3 904	363	244
13	136	9	34	60	512	31	64	107	1 504	49	846	154	3 968	375	248
14	144	17	108	61	528	17	66	108	1 536	71	48	155	4 032	127	168
15	152	9	38	62	544	35	68	109	1 568	13	28	156	4 096	31	64
16	160	21	120	63	560	227	420	110	1 600	17	80	157	4 160	33	130
17	168	101	84	64	576	65	96	111	1 632	25	102	158	4 224	43	264
18	176	21	44	65	592	19	74	112	1 664	183	104	159	4 288	33	134
19	184	57	46	66	608	37	76	113	1 696	55	954	160	4 352	477	408
20	192	23	48	67	624	41	234	114	1 728	127	96	161	4 416	35	138
21	200	13	50	68	640	39	80	115	1 760	27	110	162	4 480	233	280
22	208	27	52	69	656	185	82	116	1 792	29	112	163	4 544	357	142
23	216	11	36	70	672	43	252	117	1 824	29	114	164	4 608	337	480
24	224	27	56	71	688	21	86	118	1 856	57	116	165	4 672	37	146
25	232	85	58	72	704	155	44	119	1 888	45	354	166	4 736	71	444
26	240	29	60	73	720	79	120	120	1 920	31	120	167	4 800	71	120
27	248	33	62	74	736	139	92	121	1 952	59	610	168	4 864	37	152
28	256	15	32	75	752	23	94	122	1 984	185	124	169	4 928	39	462
29	264	17	198	76	768	217	48	123	2 016	113	420	170	4 992	127	234
30	272	33	68	77	784	25	98	124	2 048	31	64	171	5 056	39	158
31	280	103	210	78	800	17	80	125	2 112	17	66	172	5 120	39	80
32	288	19	36	79	816	127	102	126	2 176	171	136	173	5 184	31	96
33	296	19	74	80	832	25	52	127	2 240	209	420	174	5 248	113	902
34	304	37	76	81	848	239	106	128	2 304	253	216	175	5 312	41	166
35	312	19	78	82	864	17	48	129	2 368	367	444	176	5 376	251	336
36	320	21	120	83	880	137	110	130	2 432	265	456	177	5 440	43	170
37	328	21	82	84	896	215	112	131	2 496	181	468	178	5 504	21	86
38	336	115	84	85	912	29	114	132	2 560	39	80	179	5 568	43	174
39	344	193	86	86	928	15	58	133	2 624	27	164	180	5 632	45	176
40	352	21	44	87	944	147	118	134	2 688	127	504	181	5 696	45	178
41	360	133	90	88	960	29	60	135	2 752	143	172	182	5 760	161	120
42	368	81	46	89	976	59	122	136	2 816	43	88	183	5 824	89	182
43	376	45	94	90	992	65	124	137	2 880	29	300	184	5 888	323	184
44	384	23	48	91	1 008	55	84	138	2 944	45	92	185	5 952	47	186
45	392	243	98	92	1 024	31	64	139	3 008	157	188	186	6 016	23	94
46	400	151	40	93	1 056	17	66	140	3 072	47	96	187	6 080	47	190
47	408	155	102	94	1 088	171	204	141	3 136	13	28	188	6 144	263	480

6.1.5 Rate matching

6.1.5.1 Rate matching for turbo coded transport channels

The rate matching for turbo coded transport channels is defined per coded block and consists of interleaving the three information bit streams $d_k^{(0)}$, $d_k^{(1)}$ and $d_k^{(2)}$, followed by the collection of bits and the generation of a circular buffer as depicted in figure 6.1.5.1-1. The output bits for each code block are transmitted as described in clause 6.1.5.3.

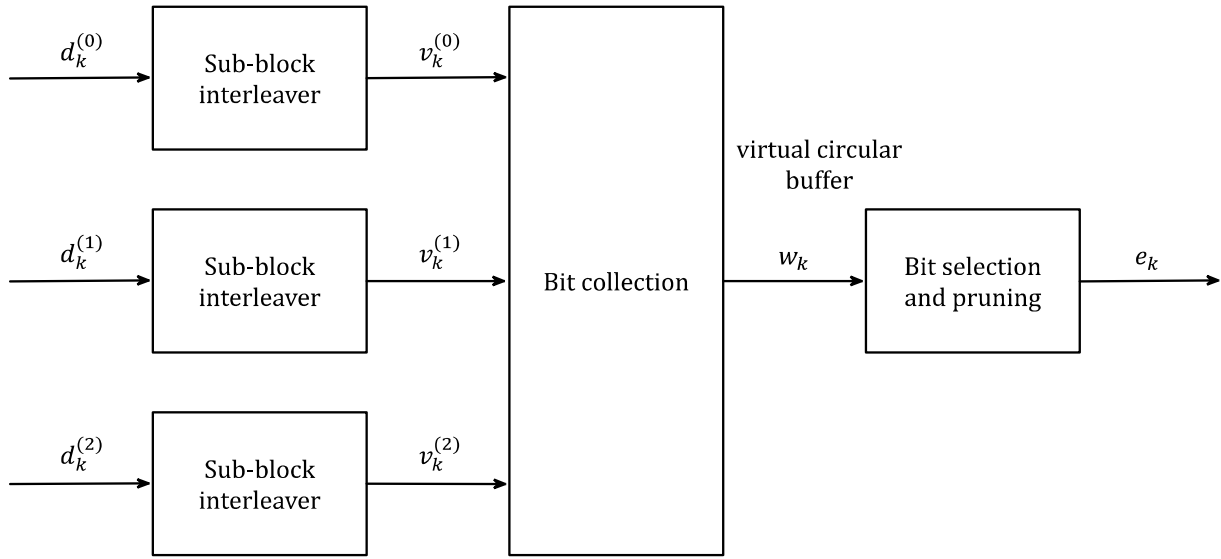

Figure 6.1.5.1-1: Rate matching for turbo coded transport channels

The bit stream $d_k^{(0)}$ is interleaved according to the sub-block interleaver defined in clause 6.1.5.2 with an output sequence defined as $v_0^{(0)}, v_1^{(0)}, v_2^{(0)}, \dots, v_{K_{\Pi}-1}^{(0)}$ and where K_{Π} is defined in clause 6.1.5.2.

The bit stream $d_k^{(1)}$ is interleaved according to the sub-block interleaver defined in clause 6.1.5.2 with an output sequence defined as $v_0^{(1)}, v_1^{(1)}, v_2^{(1)}, \dots, v_{K_{\Pi}-1}^{(1)}$.

The bit stream $d_k^{(2)}$ is interleaved according to the sub-block interleaver defined in clause 6.1.5.2 with an output sequence defined as $v_0^{(2)}, v_1^{(2)}, v_2^{(2)}, \dots, v_{K_{\Pi}-1}^{(2)}$.

The sequence of bits e_k for transmission is generated according to clause 6.1.5.3.

6.1.5.2 Sub-block interleaver

The bits input to the block interleaver are denoted by $d_0^{(i)}, d_1^{(i)}, d_2^{(i)}, \dots, d_{D-1}^{(i)}$, where D is the number of bits. The output bit sequence from the block interleaver is derived as follows:

- 1) Assign $C_{subblock}^{TC} = 32$ to be the number of columns of the matrix. The columns of the matrix are numbered 0, 1, 2, ..., $C_{subblock}^{TC} - 1$ from left to right.
- 2) Determine the number of rows of the matrix $R_{subblock}^{TC}$, by finding minimum integer $R_{subblock}^{TC}$ such that:

$$D \leq (R_{subblock}^{TC} \times C_{subblock}^{TC})$$

The rows of rectangular matrix are numbered 0, 1, 2, ..., $R_{subblock}^{TC} - 1$ from top to bottom.

- 3) If $(R_{subblock}^{TC} \times C_{subblock}^{TC}) > D$, then $N_D = (R_{subblock}^{TC} \times C_{subblock}^{TC} - D)$ dummy bits are padded such that $y_k = \langle NULL \rangle$ for $k = 0, 1, \dots, N_D - 1$. Then, $y_{N_D+k} = d_k^{(i)}$, $k = 0, 1, \dots, D-1$, and the bit sequence y_k is written into the $(R_{subblock}^{TC} \times C_{subblock}^{TC})$ matrix row by row starting with bit y_0 in column 0 of row 0:

$$\begin{bmatrix} y_0 & y_1 & y_2 & \cdots & y_{C_{subblock}^{TC}-1} \\ y_{C_{subblock}^{TC}} & y_{C_{subblock}^{TC}+1} & y_{C_{subblock}^{TC}+2} & \cdots & y_{2C_{subblock}^{TC}-1} \\ \vdots & \vdots & \vdots & \ddots & \vdots \\ y_{(R_{subblock}^{TC}-1) \times C_{subblock}^{TC}} & y_{(R_{subblock}^{TC}-1) \times C_{subblock}^{TC}+1} & y_{(R_{subblock}^{TC}-1) \times C_{subblock}^{TC}+2} & \cdots & y_{(R_{subblock}^{TC} \times C_{subblock}^{TC}-1)} \end{bmatrix}$$

For $d_k^{(0)}$ and $d_k^{(1)}$:

- 4) Perform the inter-column permutation for the matrix based on the pattern $\langle P(j) \rangle_{j \in \{0,1,\dots,C_{subblock}^{TC}-1\}}$ that is shown in table 6.1.5.2-1, where $P(j)$ is the original column position of the j -th permuted column. After permutation of the columns, the inter-column permuted $(R_{subblock}^{TC} \times C_{subblock}^{TC})$ matrix is equal to:

$$\begin{bmatrix} y_{P(0)} & y_{P(1)} & y_{P(2)} & \dots & y_{P(C_{subblock}^{TC}-1)} \\ y_{P(0)+C_{subblock}^{TC}} & y_{P(1)+C_{subblock}^{TC}} & y_{P(2)+C_{subblock}^{TC}} & \dots & y_{P(C_{subblock}^{TC}-1)+C_{subblock}^{TC}} \\ \vdots & \vdots & \vdots & \ddots & \vdots \\ y_{P(0)+(R_{subblock}^{TC}-1) \times C_{subblock}^{TC}} & y_{P(1)+(R_{subblock}^{TC}-1) \times C_{subblock}^{TC}} & y_{P(2)+(R_{subblock}^{TC}-1) \times C_{subblock}^{TC}} & \dots & y_{P(C_{subblock}^{TC}-1)+(R_{subblock}^{TC}-1) \times C_{subblock}^{TC}} \end{bmatrix}$$

- 5) The output of the block interleaver is the bit sequence read out column by column from the inter-column permuted $(R_{subblock}^{TC} \times C_{subblock}^{TC})$ matrix. The bits after sub-block interleaving are denoted by: $v_0^{(i)}, v_1^{(i)}, v_2^{(i)}, \dots, v_{K_{\Pi}-1}^{(i)}$, where $v_0^{(i)}$ corresponds to $y_{P(0)}, v_1^{(i)}$ to $y_{P(0)+C_{subblock}^{TC}} \dots$ and $K_{\Pi} = (R_{subblock}^{TC} \times C_{subblock}^{TC})$.

For $d_k^{(2)}$:

- 6) The output of the sub-block interleaver is denoted by $v_0^{(2)}, v_1^{(2)}, v_2^{(2)}, \dots, v_{K_{\Pi}-1}^{(2)}$, where $v_k^{(2)} = y_{\pi(k)}$ and where:

$$\pi(k) \xrightarrow{\tau} \left(P \left(\left\lfloor \frac{k}{R_{subblock}^{TC}} \right\rfloor \right) + C_{subblock}^{TC} \times (k \bmod R_{subblock}^{TC}) + 1 \right) \bmod K_{\Pi}$$

The permutation function P is defined in table 6.1.5.2-1.

Table 6.1.5.2-1 Inter-column permutation pattern for sub-block interleaver

Number of columns $C_{subblock}^{TC}$	Inter-column permutation pattern $\langle P(0), P(1), \dots, P(C_{subblock}^{TC}-1) \rangle$
32	$\langle 0, 16, 8, 24, 4, 20, 12, 28, 2, 18, 10, 26, 6, 22, 14, 30, 1, 17, 9, 25, 5, 21, 13, 29, 3, 19, 11, 27, 7, 23, 15, 31 \rangle$

6.1.5.3 Bit collection, selection and transmission

The circular buffer of length $K_w = 3K_{\Pi}$ for the r -th coded block is generated as follows:

$$w_k = v_k^{(0)} \text{ for } k = 0, \dots, K_{\Pi} - 1$$

$$w_{K_{\Pi}+2k} = v_k^{(1)} \text{ for } k = 0, \dots, K_{\Pi} - 1$$

$$w_{K_{\Pi}+2k+1} = v_k^{(2)} \text{ for } k = 0, \dots, K_{\Pi} - 1$$

Denote the soft buffer size for the transport block by N_{IR} bits and the soft buffer size for the r -th code block by N_{cb} bits. The size N_{cb} is obtained as follows, where C is the number of code blocks computed in clause 6.1.3:

$$N_{cb} = \min \left(\left\lfloor \frac{N_{IR}}{C} \right\rfloor, K_w \right),$$

where N_{IR} is equal to:

$$N_{IR} = \left\lfloor \frac{N_{soft}}{\min(M_{DL_HARQ}, M_{limit})} \right\rfloor$$

Where N_{soft} is the total number of soft channel bits according to the Radio Device class category defined in annex A.

M_{DL_HARQ} is the maximum number of DL HARQ processes according to the Radio Device class category defined in annex B.

M_{limit} is a constant equal to 8.

Denoting by E the rate matching output sequence length for the r -th coded block, and rv_{idx} the redundancy version number for this transmission ($rv_{idx} = 0, 1, 2$ or 3), the rate matching output bit sequence is $e_k, k = 0, 1, \dots, E - 1$.

Define by $G = N_{subc}^{PDC} \cdot N_{SS} \cdot N_{bps}$ the total number of bits available for the transmission of one transport block.

Set $G' = G / (N_{SS} \cdot N_{bps}) = N_{subc}^{PDC}$ where N_{bps} is equal to 1 for BPSK, 2 for QPSK, 4 for 16-QAM, 6 for 64-QAM, 8 for 256-QAM and 10 for 1024-QAM, and where:

- N_{SS} is equal to the number of spatial layers a transport block is mapped onto

Set $\gamma = G' \bmod C$, where C is the number of code blocks computed in clause 6.1.3.

if $r \leq C - \gamma - 1$

$$\text{set } E = N_{SS} \cdot N_{bps} \cdot \lceil G' / C \rceil = N_{SS} \cdot N_{bps} \cdot \lceil N_{subc}^{PDC} / C \rceil$$

else

$$\text{set } E = N_{SS} \cdot N_{bps} \cdot \lceil G' / C \rceil = N_{SS} \cdot N_{bps} \cdot \lceil N_{subc}^{PDC} / C \rceil$$

end if

Set $k_0 = R_{subblock}^{TC} \cdot \left(2 \cdot \left\lceil \frac{N_{cb}}{8 \cdot R_{subblock}^{TC}} \right\rceil \cdot r v_{idx} + 2 \right)$, where $R_{subblock}^{TC}$ is the number of rows defined in clause 6.1.5.2.

Set $k = 0$ and $j = 0$

while $\{k < E\}$

if $w_{(k_0+j) \bmod N_{cb}} \neq \langle \text{NULL} \rangle$

$$e_k = w_{(k_0+j) \bmod N_{cb}}$$

$$k = k + 1$$

end if

$$j = j + 1$$

end while

6.1.6 Code block concatenation

The input bit sequence for the code block concatenation block are the sequences e_{rk} , for $r = 0, \dots, C - 1$ and $k = 0, \dots, E_r - 1$. The output bit sequence from the code block concatenation block is the sequence f_k for $k = 0, \dots, G - 1$.

The code block concatenation consists of sequentially concatenating the rate matching outputs for the different code blocks. Therefore,

Set $k = 0$ and $r = 0$

while $r < C$

Set $j = 0$

while $j < E_r$

$$f_k = e_{rj}$$

$$k = k + 1$$

$$j = j + 1$$

end while

$$r = r + 1$$

end while

6.2 Pseudo-random sequence generation

Generic pseudo random sequence is defined by a length 31 Gold sequence. The output sequence $g(n)$ if length N_{PN} where $n = 0, 1, \dots, N_{PN} - 1$ is defined by:

$$\begin{aligned} g(n) &= (x_1(n + N_C) + x_1(n + N_C)) \bmod 2 \\ x_1(n + 31) &= (x_1(n + 3) + x_1(n)) \bmod 2 \\ x_2(n + 31) &= (x_2(n + 3) + x_2(n + 2) + x_2(n + 1) + x_2(n)) \bmod 2 \end{aligned} ,$$

where $N_C = 1\ 600$ and the first m-sequence shall be initialized with:

$$x_1(0) = 1, x_1(n) = 0, \forall n = \{1, 2, \dots, 30\}$$

The initialization of the second m-sequence $x_2(n)$ is denoted by:

$$g_{init} = \sum_{i=0}^{30} x_2(i) \cdot 2^i,$$

with the value depending on the application sequence.

6.3 Modulation

6.3.1 Symbol mapping

6.3.1.1 Overview

The modulation mapper takes binary digits, 0 or 1, as input and produces complex-valued modulation symbols as output.

6.3.1.2 BPSK

In case of BPSK modulation, bit $d(i)$ is mapped to complex-valued modulation symbol $x(i)$ according to:

$$\begin{aligned} x(i) &= \frac{1}{\sqrt{2}} \{ (1 - 2 * d(i)) \\ &\quad + j(1 - 2 * d(i)) \} \end{aligned}$$

6.3.1.3 QPSK

In case of QPSK modulation, pair of bits, $d(i)$, $d(i + 1)$ are mapped to complex-valued modulation symbols $x(i)$ according to:

$$\begin{aligned} x(i) &= \frac{1}{\sqrt{2}} \{ (1 - 2 * d(i)) \\ &\quad + j(1 - 2 * d(i + 1)) \} \end{aligned}$$

6.3.1.4 16-QAM

In case of 16-QAM modulation, quadruplets of bits, $d(i)$, $d(i + 1)$, $d(i + 2)$, $d(i + 3)$ are mapped to complex-valued modulation symbols $x(i)$ according to:

$$\begin{aligned} x(i) &= \frac{1}{\sqrt{10}} \{ (1 - 2 * d(i)) (2 - (1 - 2 * d(i + 2))) \\ &\quad + j (1 - 2 * d(i + 1)) (2 - (1 - 2 * d(i + 3))) \} \end{aligned}$$

6.3.1.5 64-QAM

In case of 64-QAM modulation, hexuplets of bits, $d(i)$, $d(i + 1)$, $d(i + 2)$, $d(i + 3)$, $d(i + 4)$, $d(i + 5)$, are mapped to complex-valued modulation symbols $x(i)$ according to:

$$x(i) = \frac{1}{\sqrt{42}} \left\{ (1 - 2 * d(i)) \left(4 - (1 - 2 * d(i + 2)) \left(2 - (1 - 2 * d(i + 4)) \right) \right) \right. \\ \left. + j (1 - 2 * d(i + 1)) \left(4 - (1 - 2 * d(i + 3)) \left(2 - (1 - 2 * d(i + 5)) \right) \right) \right\}$$

6.3.1.6 256-QAM

In case of 256-QAM modulation, octuplets of bits, $d(i)$, $d(i + 1)$, $d(i + 2)$, $d(i + 3)$, $d(i + 4)$, $d(i + 5)$, $d(i + 6)$, $d(i + 7)$ are mapped to complex-valued modulation symbols $x(i)$ according to:

$$x(i) = \frac{1}{\sqrt{170}} \left\{ (1 - 2 * d(i)) \left(8 - (1 - 2 * d(i + 2)) \left(4 - (1 - 2 * d(i + 4)) \left(2 - (1 - 2 * d(i + 6)) \right) \right) \right) \right. \\ \left. + j (1 - 2 * d(i + 1)) \left(8 - (1 - 2 * d(i + 3)) \left(4 - (1 - 2 * d(i + 5)) \left(2 - (1 - 2 * d(i + 7)) \right) \right) \right) \right\}$$

6.3.1.7 1024-QAM

In case of 1024-QAM modulation, decuplets of bits, $d(i)$, $d(i + 1)$, $d(i + 2)$, $d(i + 3)$, $d(i + 4)$, $d(i + 5)$, $d(i + 6)$, $d(i + 7)$, $d(i + 8)$, $d(i + 9)$ are mapped to complex-valued modulation symbols $x(i)$ according to:

$$x(i) = \frac{1}{\sqrt{682}} \left\{ (1 - 2 * d(i)) \left(16 - (1 - 2 * d(i + 2)) \left(8 - (1 - 2 * d(i + 4)) \left(4 - (1 - 2 * d(i + 6)) \left(2 - (1 - 2 * d(i + 8)) \right) \right) \right) \right) \right. \\ \left. + j (1 - 2 * d(i + 1)) \left(16 - (1 - 2 * d(i + 3)) \left(8 - (1 - 2 * d(i + 5)) \left(4 - (1 - 2 * d(i + 7)) \left(2 - (1 - 2 * d(i + 9)) \right) \right) \right) \right) \right\}$$

6.3.2 Spatial multiplexing

The modulated transport block to spatial stream multiplexing shall be done according to table 6.3.2-1, where the complex valued modulation symbols $x(i)$, $i = 0, \dots, M_{symb}$ is mapped to the modulated symbol in spatial stream $x^{(s)}(i)$, $i = 0, \dots, M_{symb}^{stream}$ for stream s and $M_{symb}^{stream} = M_{symb} / N_{SS}$. The number of spatial streams is less than or equal to the number of antenna ports used for the transmission of the channel.

Table 6.3.2-1: Modulated transport block to spatial stream mapping

Number of spatial streams	Modulated transport block to spatial stream mapping
1	$x^{(0)}(i) = x(i)$
2	$x^{(0)}(i) = x(2i)$ $x^{(1)}(i) = x(2i + 1)$
4	$x^{(0)}(i) = x(4i)$ $x^{(1)}(i) = x(4i + 1)$ $x^{(2)}(i) = x(4i + 2)$ $x^{(3)}(i) = x(4i + 3)$
8	$x^{(0)}(i) = x(8i)$ $x^{(1)}(i) = x(8i + 1)$ $x^{(2)}(i) = x(8i + 2)$ $x^{(3)}(i) = x(8i + 3)$ $x^{(4)}(i) = x(8i + 4)$ $x^{(5)}(i) = x(8i + 5)$ $x^{(6)}(i) = x(8i + 6)$ $x^{(7)}(i) = x(8i + 7)$

6.3.3 Transmit stream mapping

6.3.3.1 Transmit stream mapping for spatial multiplexing and for single antenna

If transmit diversity is not used the precoding matrix is identity matrix, thus:

$$y^{(s)}(i) = x^{(s)}(i), i = 0, \dots, M_{\text{stream}}^{\text{stream}} - 1, s = 0, \dots, N_{\text{SS}}$$

where $y^{(s)}(i)$ denotes transmission in transmit stream index s and $x^{(s)}(i)$ is modulated symbol for spatial stream index s and time index i and number of transmit streams $N_{\text{TS}} = N_{\text{SS}}$.

6.3.3.2 Transmit diversity precoding

When transmit diversity is used the pair of symbols $[x^{(0)}(2i), x^{(0)}(2i+1)]^T, i = 0, \dots, M_{\text{stream}}^{\text{stream}}/2 - 1$ of spatial stream 0 shall be precoded according to:

$$\begin{bmatrix} y^{(0)}(2i) \\ \vdots \\ y^{(N_{\text{TS}}-1)}(2i) \\ y^{(0)}(2i+1) \\ \vdots \\ y^{(N_{\text{TS}}-1)}(2i+1) \end{bmatrix} = Y_i \begin{bmatrix} \text{Re}\{x^{(0)}(2i)\} \\ \text{Re}\{x^{(0)}(2i+1)\} \\ \text{Im}\{x^{(0)}(2i)\} \\ \text{Im}\{x^{(0)}(2i+1)\} \end{bmatrix}, i = 0, \dots, M_{\text{stream}}^{\text{stream}} - 1$$

where $y^{(t)}(l)$ is the transmit diversity precoded transmission in transmit stream t and index l and $x^{(s)}(l)$ is modulated symbol for spatial stream index s and time index l . The precoding matrices Y_i are given by tables 6.3.3.2-1 to 6.3.3.2-3 for index i and for each transmit diversity scheme.

Table 6.3.3.2-1: Precoding matrix Y_i for two antenna transmit diversity using two transmit streams

Y_i	
$\begin{bmatrix} 1 & 0 & j & 0 \\ 0 & -1 & 0 & j \\ 0 & 1 & 0 & j \\ 1 & 0 & -j & 0 \end{bmatrix}$	

Table 6.3.3.2-2: Precoding matrix Y_i for four antenna transmit diversity using four transmit streams

index $i \bmod 6$	Y_i (ordered from left to right in increasing order of index)			
	0 - 3	$\begin{bmatrix} 1 & 0 & j & 0 \\ 0 & -1 & 0 & j \\ 0 & 0 & 0 & 0 \\ 0 & 0 & 0 & 0 \\ 0 & 1 & 0 & j \\ 1 & 0 & -j & 0 \\ 0 & 0 & 0 & 0 \\ 0 & 0 & 0 & 0 \end{bmatrix}$	$\begin{bmatrix} 0 & 0 & 0 & 0 \\ 0 & 0 & 0 & 0 \\ 1 & 0 & j & 0 \\ 0 & -1 & 0 & j \\ 0 & 0 & 0 & 0 \\ 0 & 0 & 0 & 0 \\ 0 & 1 & 0 & j \\ 0 & 1 & 0 & j \\ 1 & 0 & -j & 0 \end{bmatrix}$	$\begin{bmatrix} 1 & 0 & j & 0 \\ 0 & 0 & 0 & 0 \\ 0 & -1 & 0 & j \\ 0 & 0 & 0 & 0 \\ 0 & 1 & 0 & j \\ 0 & 0 & 0 & 0 \\ 1 & 0 & -j & 0 \\ 0 & 0 & 0 & 0 \end{bmatrix}$
4 - 5	$\begin{bmatrix} 1 & 0 & j & 0 \\ 0 & 0 & 0 & 0 \\ 0 & 0 & 0 & 0 \\ 0 & -1 & 0 & j \\ 0 & 1 & 0 & j \\ 0 & 0 & 0 & 0 \\ 0 & 0 & 0 & 0 \\ 1 & 0 & -j & 0 \end{bmatrix}$	$\begin{bmatrix} 0 & 0 & 0 & 0 \\ 1 & 0 & j & 0 \\ 0 & -1 & 0 & j \\ 0 & 0 & 0 & 0 \\ 0 & 0 & 0 & 0 \\ 0 & 1 & 0 & j \\ 1 & 0 & -j & 0 \\ 0 & 0 & 0 & 0 \end{bmatrix}$	-	-

The same precoding or beamforming is applied to PCC, PDC, DRS and STF transmit streams for the precoding to be transparent to the receiver.

Single antenna transmission precoding matrix is identity matrix $W = 1$.

Open loop MIMO and transmit diversity transmissions can be done with any orthogonal precoding matrix which is transparent to the receiver.

The precoding matrix W are given by tables 6.3.4-1 to 6.3.4-5 for each closed loop codebook index applicable for given transmission.

Channel sounding packet shall always be transmitted with identity precoding matrix, thus using codebook index 0 of tables 6.3.4-3, 6.3.4-5 and 6.3.4-6.

Table 6.3.4-1: Precoding matrix W for single transmit stream transmission using two antenna ports

Codebook index	W (ordered from left to right in increasing order of index)							
0 - 5	$\begin{bmatrix} 1 \\ 0 \end{bmatrix}$	$\begin{bmatrix} 0 \\ 1 \end{bmatrix}$	$\frac{1}{\sqrt{2}} \begin{bmatrix} 1 \\ 1 \end{bmatrix}$	$\frac{1}{\sqrt{2}} \begin{bmatrix} 1 \\ -1 \end{bmatrix}$	$\frac{1}{\sqrt{2}} \begin{bmatrix} 1 \\ j \end{bmatrix}$	$\frac{1}{\sqrt{2}} \begin{bmatrix} 1 \\ -j \end{bmatrix}$	-	-

Table 6.3.4-2: Precoding matrix W for single transmit stream transmission using four antenna ports

Codebook index	W (ordered from left to right in increasing order of index)							
0 - 7	$\begin{bmatrix} 1 \\ 0 \\ 0 \\ 0 \end{bmatrix}$	$\begin{bmatrix} 0 \\ 1 \\ 0 \\ 0 \end{bmatrix}$	$\begin{bmatrix} 0 \\ 0 \\ 1 \\ 0 \end{bmatrix}$	$\begin{bmatrix} 0 \\ 0 \\ 0 \\ 1 \end{bmatrix}$	$\frac{1}{\sqrt{2}} \begin{bmatrix} 1 \\ 0 \\ 1 \\ 0 \end{bmatrix}$	$\frac{1}{\sqrt{2}} \begin{bmatrix} 1 \\ 0 \\ -1 \\ 0 \end{bmatrix}$	$\frac{1}{\sqrt{2}} \begin{bmatrix} 1 \\ 0 \\ j \\ 0 \end{bmatrix}$	$\frac{1}{\sqrt{2}} \begin{bmatrix} 1 \\ 0 \\ -j \\ 0 \end{bmatrix}$
8 - 15	$\frac{1}{\sqrt{2}} \begin{bmatrix} 0 \\ 1 \\ 1 \\ 0 \end{bmatrix}$	$\frac{1}{\sqrt{2}} \begin{bmatrix} 0 \\ 1 \\ 0 \\ -1 \end{bmatrix}$	$\frac{1}{\sqrt{2}} \begin{bmatrix} 0 \\ 1 \\ 0 \\ j \end{bmatrix}$	$\frac{1}{\sqrt{2}} \begin{bmatrix} 0 \\ 1 \\ 0 \\ -j \end{bmatrix}$	$\frac{1}{2} \begin{bmatrix} 1 \\ 1 \\ 1 \\ 1 \end{bmatrix}$	$\frac{1}{2} \begin{bmatrix} 1 \\ 1 \\ 1 \\ j \end{bmatrix}$	$\frac{1}{2} \begin{bmatrix} 1 \\ 1 \\ -1 \\ -1 \end{bmatrix}$	$\frac{1}{2} \begin{bmatrix} 1 \\ 1 \\ -1 \\ -j \end{bmatrix}$
16 - 23	$\frac{1}{2} \begin{bmatrix} 1 \\ j \\ 1 \\ j \end{bmatrix}$	$\frac{1}{2} \begin{bmatrix} 1 \\ j \\ j \\ -1 \end{bmatrix}$	$\frac{1}{2} \begin{bmatrix} 1 \\ j \\ -1 \\ -j \end{bmatrix}$	$\frac{1}{2} \begin{bmatrix} 1 \\ j \\ -j \\ 1 \end{bmatrix}$	$\frac{1}{2} \begin{bmatrix} 1 \\ -1 \\ 1 \\ -1 \end{bmatrix}$	$\frac{1}{2} \begin{bmatrix} 1 \\ -1 \\ j \\ -j \end{bmatrix}$	$\frac{1}{2} \begin{bmatrix} 1 \\ -1 \\ -1 \\ 1 \end{bmatrix}$	$\frac{1}{2} \begin{bmatrix} 1 \\ -1 \\ -j \\ j \end{bmatrix}$
24 - 27	$\frac{1}{2} \begin{bmatrix} 1 \\ -j \\ 1 \\ -j \end{bmatrix}$	$\frac{1}{2} \begin{bmatrix} 1 \\ -j \\ j \\ 1 \end{bmatrix}$	$\frac{1}{2} \begin{bmatrix} 1 \\ -j \\ -1 \\ j \end{bmatrix}$	$\frac{1}{2} \begin{bmatrix} 1 \\ -j \\ -j \\ -1 \end{bmatrix}$	-	-	-	-

Table 6.3.4-3: Precoding matrix W for dual transmit stream transmission using two antenna ports

Codebook index	W (ordered from left to right in increasing order of index)		
0 - 2	$\frac{1}{\sqrt{2}} \begin{bmatrix} 1 & 0 \\ 0 & 1 \end{bmatrix}$	$\frac{1}{2} \begin{bmatrix} 1 & 1 \\ 1 & -1 \end{bmatrix}$	$\frac{1}{2} \begin{bmatrix} 1 & 1 \\ j & -j \end{bmatrix}$

Table 6.3.4-4: Precoding matrix W for dual transmit stream transmission using four antenna ports

Codebook index	W (ordered from left to right in increasing order of index)			
	0 - 3	$\frac{1}{\sqrt{2}} \begin{bmatrix} 1 & 0 \\ 0 & 1 \\ 0 & 0 \\ 0 & 0 \end{bmatrix}$	$\frac{1}{\sqrt{2}} \begin{bmatrix} 1 & 0 \\ 0 & 0 \\ 0 & 1 \\ 0 & 0 \end{bmatrix}$	$\frac{1}{\sqrt{2}} \begin{bmatrix} 1 & 0 \\ 0 & 0 \\ 0 & 0 \\ 0 & 1 \end{bmatrix}$
4 - 7	$\frac{1}{\sqrt{2}} \begin{bmatrix} 0 & 0 \\ 1 & 0 \\ 0 & 0 \\ 0 & 1 \end{bmatrix}$	$\frac{1}{\sqrt{2}} \begin{bmatrix} 0 & 0 \\ 0 & 0 \\ 1 & 0 \\ 0 & 1 \end{bmatrix}$	$\frac{1}{2} \begin{bmatrix} 1 & 0 \\ 0 & 1 \\ 1 & 0 \\ 0 & -j \end{bmatrix}$	$\frac{1}{2} \begin{bmatrix} 1 & 0 \\ 0 & 1 \\ 1 & 0 \\ 0 & j \end{bmatrix}$
8 - 11	$\frac{1}{2} \begin{bmatrix} 1 & 0 \\ 0 & 1 \\ -j & 0 \\ 0 & 1 \end{bmatrix}$	$\frac{1}{2} \begin{bmatrix} 1 & 0 \\ 0 & 1 \\ -j & 0 \\ 0 & -1 \end{bmatrix}$	$\frac{1}{2} \begin{bmatrix} 1 & 0 \\ 0 & 1 \\ -1 & 0 \\ 0 & -j \end{bmatrix}$	$\frac{1}{2} \begin{bmatrix} 1 & 0 \\ 0 & 1 \\ -1 & 0 \\ 0 & j \end{bmatrix}$
12 - 15	$\frac{1}{2} \begin{bmatrix} 1 & 0 \\ 0 & 1 \\ j & 0 \\ 0 & 1 \end{bmatrix}$	$\frac{1}{2} \begin{bmatrix} 1 & 0 \\ 0 & 1 \\ j & 0 \\ 0 & -1 \end{bmatrix}$	$\frac{1}{2\sqrt{2}} \begin{bmatrix} 1 & 1 \\ 1 & 1 \\ 1 & -1 \\ 1 & -1 \end{bmatrix}$	$\frac{1}{2\sqrt{2}} \begin{bmatrix} 1 & 1 \\ 1 & 1 \\ j & -j \\ j & -j \end{bmatrix}$
16 - 19	$\frac{1}{2\sqrt{2}} \begin{bmatrix} 1 & 1 \\ j & j \\ 1 & -1 \\ j & -j \end{bmatrix}$	$\frac{1}{2\sqrt{2}} \begin{bmatrix} 1 & 1 \\ j & j \\ j & -j \\ -1 & 1 \end{bmatrix}$	$\frac{1}{2\sqrt{2}} \begin{bmatrix} 1 & 1 \\ -1 & -1 \\ 1 & -1 \\ -1 & 1 \end{bmatrix}$	$\frac{1}{2\sqrt{2}} \begin{bmatrix} 1 & 1 \\ -1 & -1 \\ j & -j \\ -j & j \end{bmatrix}$
20 - 21	$\frac{1}{2\sqrt{2}} \begin{bmatrix} 1 & 1 \\ -j & -j \\ 1 & -1 \\ -j & j \end{bmatrix}$	$\frac{1}{2\sqrt{2}} \begin{bmatrix} 1 & 1 \\ -j & -j \\ j & -j \\ 1 & -1 \end{bmatrix}$	-	-

Table 6.3.4-5: Precoding matrix W for four transmit stream transmission using four antenna ports

Codebook index	W (ordered from left to right in increasing order of index)			
	0 - 3	$\frac{1}{2} \begin{bmatrix} 1 & 0 & 0 & 0 \\ 0 & 1 & 0 & 0 \\ 0 & 0 & 1 & 0 \\ 0 & 0 & 0 & 1 \end{bmatrix}$	$\frac{1}{2\sqrt{2}} \begin{bmatrix} 1 & 1 & 0 & 0 \\ 0 & 0 & 1 & 1 \\ 1 & -1 & 0 & 0 \\ 0 & 0 & 1 & -1 \end{bmatrix}$	$\frac{1}{2\sqrt{2}} \begin{bmatrix} 1 & 1 & 0 & 0 \\ 0 & 0 & 1 & 1 \\ j & -j & 0 & 0 \\ 0 & 0 & j & -j \end{bmatrix}$
4	$\frac{1}{4} \begin{bmatrix} 1 & 1 & 1 & 1 \\ 1 & -1 & 1 & -1 \\ j & j & -j & -j \\ j & -j & -j & j \end{bmatrix}$	-	-	-

Table 6.3.4-6: Precoding matrix W for eight transmit stream transmission using eight antenna ports

Codebook index	W (ordered from left to right in increasing order of index)							
	0	$\frac{1}{4} \begin{bmatrix} 1 & 0 & 0 & 0 & 0 & 0 & 0 & 0 \\ 0 & 1 & 0 & 0 & 0 & 0 & 0 & 0 \\ 0 & 0 & 1 & 0 & 0 & 0 & 0 & 0 \\ 0 & 0 & 0 & 1 & 0 & 0 & 0 & 0 \\ 0 & 0 & 0 & 0 & 1 & 0 & 0 & 0 \\ 0 & 0 & 0 & 0 & 0 & 1 & 0 & 0 \\ 0 & 0 & 0 & 0 & 0 & 0 & 1 & 0 \\ 0 & 0 & 0 & 0 & 0 & 0 & 0 & 1 \end{bmatrix}$						

6.3.5 OFDM signal generation

$$q_{n,l}^{(p)} = \frac{1}{\sqrt{N_{OCC,l}}} \sum_k z_{k,l}^{(p)} \exp(j(2\pi \cdot k/N_{DFT}^\beta) \cdot n), k = 0, \dots, N_{DCT}, n = 0, \dots, N_{DCT}$$

where l is the OFDM symbol index, $N_{OCC,l}$ is number of occupied subcarriers for OFDM symbol l , N_{DFT}^β is the discrete Fourier transform size for the scaling factor β , and $z_{k,l}^{(p)}$ is the frequency domain signal to be transformed and $q_{n,l}^{(p)}$ is the corresponding time domain signal for antenna port p . Sum of the transmit power over all transmit chains shall be normalized to 1,0 for each OFDM symbol l .

NOTE 1: Power scaling due to the transmit diversity or spatial multiplexing is built in into the precoding matrices.

NOTE 2: Number of occupied subcarriers is four times lower for STF symbol than for the other symbols, i.e.
 $4 \cdot N_{OCC,0} = N_{OCC,i}, i \neq 0$

6.3.6 Cyclic prefix insertion

Cyclic prefixes for each of the Fourier transform scaling β is $1/8$ of the N_{DFT}^β for all OFDM symbols except for the OFDM symbol 0 of the transmission packet.

For OFDM symbol 0 of the transmission packet the cyclic prefix shall equal to $3/4 \cdot N_{DFT}^\beta$ when subcarrier scaling factor $\mu = 1$ or $5/4 \cdot N_{DFT}^\beta$ when subcarrier scaling factor $\mu = \{2, 4, 8\}$.

NOTE: STF signal is defined in frequency domain for OFDM symbol 0. The cyclic prefix definitions above with frequency domain definition of STF together create 7 or 9 repetitions of $1/4 \cdot N_{DFT}^\beta$ long base sequence.

7 Transmission encoding

7.1 Transmitter block diagram

High level transmitter block diagram is depicted in figure 7.1-1. N_{SS} denotes the number of spatial streams. For PCC the number of spatial streams is fixed to one. The number of spatial streams for PDC is signalled within the Physical Header as specified ETSI TS 103 636-4 [3], clause 6.2.1. N_{TX}^{eff} is the effective number of transmit antennas. The effective number of transmit antennas is signalled with cyclic rotation of STF base sequence as defined in clause 5.2.2. Number of transmit streams N_{TS} can appropriately deduced from N_{TX}^{eff} and N_{SS} according to the table 7.2-1. The additional degrees of freedom beyond N_{TX}^{eff} can be used for beamforming and the actual number of transmit antennas N_{TX} does not need to be known to the receiver.

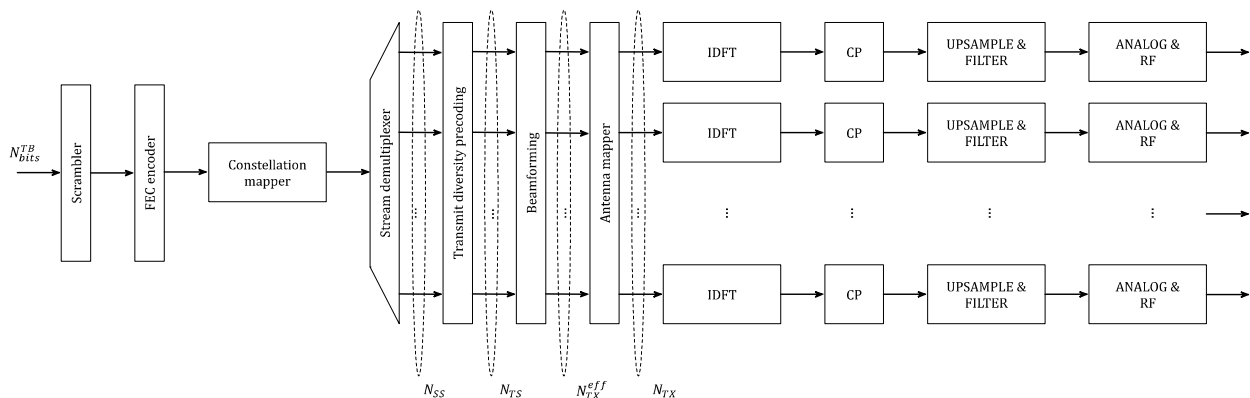

Figure 7.1-1: Transmitter Block Diagram

7.2 Transmission modes

Transmission modes available for transmitting a packet are listed in table 7.2-1. The transmission mode is signalled with:

- Cyclic rotation of STF sequence as specified in clause 5.2.2 for the number of effective transmit antennas N_{TX}^{eff} .
- Physical header field containing the number of spatial streams N_{SS} signalled in as specified in ETSI TS 103 636-4 [3].
- XOR-masking the CRC of the PCC as specified in clause 7.5.2.2 for closed loop transmission.
- XOR-masking the CRC of the PCC as specified in clause 7.5.2.3 for beamformed (precoded) transmission:
 - When precoding matrix is identity matrix the CRC of the PCC shall **NOT** be XOR-masked.
 - When precoding something else than identity matrix the CRC of the PCC shall be XOR-masked.

Closed loop transmission are beamformed according to the clause 6.3.4 and beamforming matrix shall be uniformly applied to all fields of the transmission: STF, DRS, PCC and PDC.

Open loop transmissions can be beamformed according to the clause 6.3.4 or with any other orthogonal beamforming matrix as long as the beamforming is transparent to the receiver and the beamforming is uniformly applied to all fields of transmission: STF, DRS, PCC and PDC.

NOTE: When transmission is not beamformed and it is signalled appropriately, receiver may use the channel estimates for channel sounding purposes. When transmission is beamformed the receiver sees composite of beamforming and channel response matrix.

Table 7.2-1: Transmission modes and transmission mode signalling.
CL - Closed Loop (True/False), BF - Beamformed (True/False), N_{TX} - Number of antenna ports

Radio device class N_{SS} capability = 1 as defined in Annex B									
PDC					PCC				
Transmission mode signalling	N_{TX}^{eff}	N_{SS}	CL	BF	Effective transmission mode	N_{TS}	N_{TX}	Effective transmission mode	BF
Single antenna	1	1	F	F	Single antenna	1	1	Single antenna	F
Radio device class N_{SS} capability = 2 as defined in Annex B									
PDC					PCC				
Transmission mode signalling	N_{TX}^{eff}	N_{SS}	CL	BF	Effective transmission mode	N_{TS}	N_{TX}	Effective transmission mode	BF
Transmit diversity	2	1	F	T/F	2 x 1 TxDiv	2	2	2 x 1 TxDiv	T/F
MIMO open loop	2	2	F	T/F	2 x 2 MIMO	2	2	2 x 1 TxDiv	T/F
MIMO closed loop	1	1	T	T/F	Single antenna	1	2	Single antenna	T/F
MIMO closed loop	2	2	T	T/F	2 x 2 MIMO	2	2	2 x 1 TxDiv	T/F
Radio device class N_{SS} capability = 4 as defined in Annex B									
PDC					PCC				
Transmission mode signalling	N_{TX}^{eff}	N_{SS}	CL	BF	Effective transmission mode	N_{TS}	N_{TX}	Effective transmission mode	BF
Transmit diversity	4	1	F	T/F	4 x 1 TxDiv	4	4	4 x 1 TxDiv	T/F
MIMO open loop	4	4	F	T/F	4 x 4 MIMO	4	4	4 x 1 TxDiv	T/F
MIMO closed loop	1	1	T	T/F	Single antenna	1	4	Single antenna	T/F
MIMO closed loop	2	2	T	T/F	2 x 2 MIMO	2	4	2 x 1 TxDiv	T/F
MIMO closed loop	4	4	T	T/F	4 x 4 MIMO	4	4	4 x 1 TxDiv	T/F
Radio device class N_{SS} capability = 8 as defined in Annex B									
PDC					PCC				
Transmission mode signalling	N_{TX}^{eff}	N_{SS}	CL	BF	Effective transmission mode	N_{TS}	N_{TX}	Effective transmission mode	BF
Transmit diversity	8	1	F	T/F	8 x 1 TxDiv	8	8	8 x 1 TxDiv	T/F
MIMO open loop	8	8	F	T/F	8 x 8 MIMO	8	8	8 x 1 TxDiv	T/F

7.3 Synchronization Training Field (STF) beamforming

Synchronization training field symbols $y_i^{STF,(0)}$ from transmit stream 0 as specified in clause 5.2.2 are beamformed with beamforming matrix defined in clause 6.3.4 for transmission as:

$$\begin{bmatrix} z^{(0)}(i) \\ \vdots \\ z^{(N_{TX}-1)}(i) \end{bmatrix} = W \begin{bmatrix} y^{STF,(0)}(i) \\ 0 \\ \vdots \\ 0 \end{bmatrix},$$

where the number of rows in the transmit stream vector is according to the number of transmit streams for the selected transmission mode.

7.4 Demodulation Reference Signal (DRS) beamforming

Demodulation reference symbols $y_i^{DRS,(t)}$ from transmit stream t as specified in clause 5.2.3 are beamformed with beamforming matrix defined in clause 6.3.4 for transmission as:

$$\begin{bmatrix} z^{(0)}(i) \\ \vdots \\ z^{(N_{TX}-1)}(i) \end{bmatrix} = W \begin{bmatrix} y^{DRS,(0)}(i) \\ \vdots \\ y^{DRS,(N_{TS}-1)}(i) \end{bmatrix},$$

where the number of rows in the transmit stream vector is according to the number of transmit streams for the selected transmission mode.

7.5 Physical Control Channel (PCC) encoding

7.5.1 Overall description

High level description of PCC encoding procedure is depicted in figure 7.5.1-1. Number of physical control channel payload bits N_{bits}^{PCC} is either 40 or 80 bits depending on the control channel format. The physical control channel is transmitted on $N_{subc}^{PCC} = 98$ subcarriers. The receiver shall blind decode both transport block sizes and select the one with a CRC match.

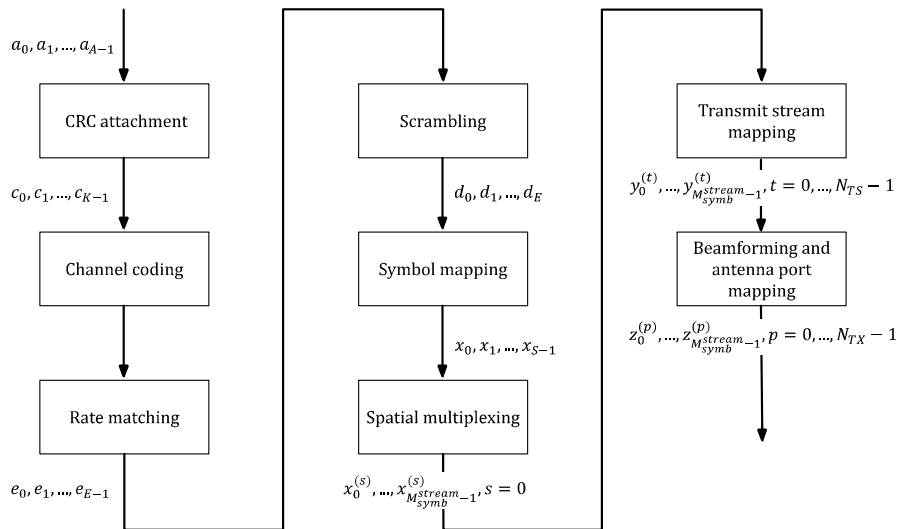

Figure 7.5.1-1: Physical control channel encoding

7.5.2 CRC calculation

7.5.2.1 Parity bit calculation

Physical control channel bits are a_0, a_1, \dots, a_{A-1} , where $A = N_{bits}^{PCC}$ and the 16 Parity bits p_0, p_1, \dots, p_{15} for the PCC are generated by using polynome $g_{CRC16}(D)$ according to the clause 6.1.2.

7.5.2.2 CRC Masking for MIMO closed loop

The 16 parity bits p_0, p_1, \dots, p_{15} are XOR masked with bitmask 0x5555 for signalling closed loop transmission.

7.5.2.3 CRC Masking for beamforming

The 16 parity bits p_0, p_1, \dots, p_{15} are XOR masked with bitmask 0xAAAA for signalling beamformed transmission.

7.5.2.4 CRC attachment

CRC attachment is defined in clause 6.1.2. The bits after CRC attachment are denoted by c_0, c_1, \dots, c_{K-1} , where $K = A + L$, where $L = 16$.

7.5.3 Channel coding & rate matching

The bit sequence c_0, c_1, \dots, c_{K-1} is channel encoded using the turbo encoder defined in clause 6.1.4 and rate matched to transmission on $N_{subc}^{PCC} = 98$ subcarriers with $N_{bps} = 2$ for QPSK modulation and with single spatial stream $N_{SS} = 1$ as specified in clause 6.1.5. For all PCC transmissions redundancy version number $rv_{idx} = 0$.

The bits after channel encoding are denoted by e_0, e_1, \dots, e_{E-1} , where $E = N_{subc}^{PCC} N_{bps}$.

7.5.4 Scrambling

The block channel encoded bits e_0, e_1, \dots, e_{E-1} , shall be scrambled with a sequence prior to CRC attachment, resulting in a block of scrambled bits:

$$d(i) = (e(i) + g(i)) \bmod 2$$

where the scrambling sequence $g(i)$ is given by clause 6.2. The scrambling sequence shall be initialized with $g_{init} = 0x44454354$.

7.5.5 Symbol mapping

Bit sequence by d_0, d_1, \dots, d_{E-1} is mapped into complex valued QPSK modulation symbols x_0, x_1, \dots, x_{S-1} as defined in clause 6.3.1.2. The length of the modulated symbol vector is $S = N_{subc}^{PCC}$.

7.5.6 Spatial multiplexing

Modulated symbols x_0, x_1, \dots, x_{S-1} are mapped to 0th spatial stream according to clause 6.3.2, thus:

$$x^{(0)}(i) = x(i)$$

where $i = 0, \dots, S - 1$ and $S = N_{subc}^{PCC}$.

7.5.7 Transmit stream mapping

Modulated symbols $x^{(0)}(i)$ from spatial stream 0 in case of single antenna transmission or spatial multiplexing are mapped directly to corresponding transmit stream as specified in clause 6.3.3.1 or in case of transmit diversity precoded as specified in clause 6.3.3.2 producing output $y^{(t)}(i)$, $i = 0, \dots, S$, where $S = N_{subc}^{PCC}$ and transmit streams $t = 0, \dots, N_{TS} - 1$ according to the transmission mode.

7.5.8 Beamforming

The modulated symbols $y^{(t)}(i)$, $i = 0, \dots, S$ from transmit streams $t = 0, \dots, N_{TS} - 1$ are beamformed according to the transmit mode as specified in clause 6.3.4 to produce PCC transmission $z^{(p)}(i)$, $i = 0, \dots, S$ on antenna port $p = 0, \dots, N_{TX}$.

7.5.9 Subcarrier mapping

Beamformed symbols $z^{(p)}(i)$, $i = 0, \dots, N_{subc}^{PCC}$, $p = 0, \dots, N_{TX} - 1$ are mapped into $N_{subc}^{PCC} = 98$ subcarriers as defined in clause 5.2.4.

7.6 Physical Data Channel (PDC) encoding

7.6.1 Overall description

PDC encoding procedure is depicted in figure 7.6.1-1.

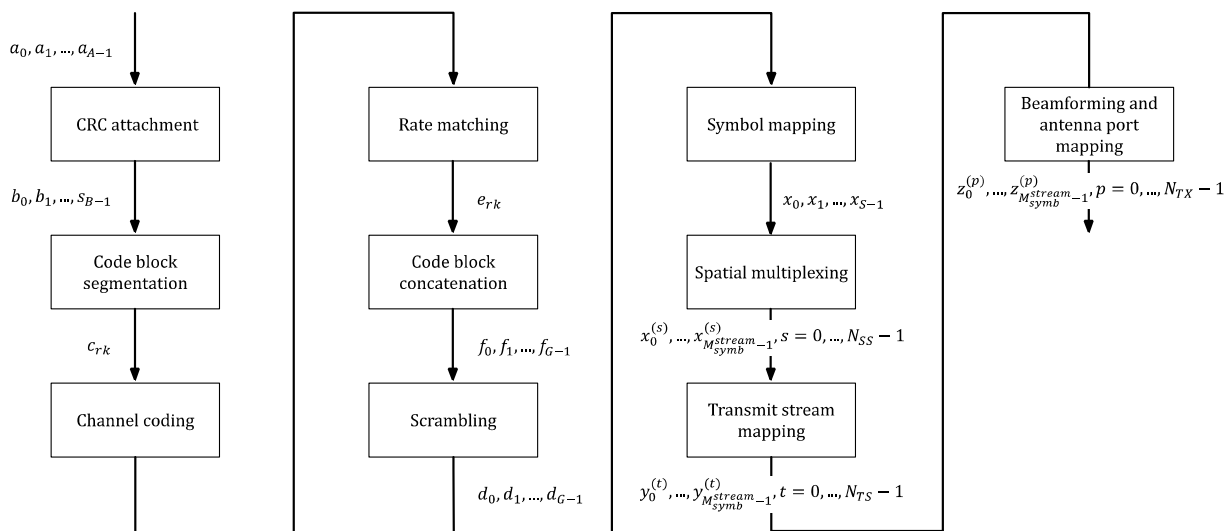

Figure 7.6.1-1: Physical Data Channel Encoding

7.6.2 CRC calculation

Physical data channel bits are a_0, a_1, \dots, a_{A-1} , where the length of transport block is given by clause 5.3 according to the transmission allocation.

Parity bits for the transport block are generated by using the polynome $g_{CRC24A}(D)$ according to the clause 6.1.2. The bits after CRC attachment are denoted by b_0, b_1, \dots, b_{B-1} , where $B = A + L$, where $L = 24$.

7.6.3 Code block segmentation

Transport block is segmented into C independently turbo encoded blocks, each individually protected with 24-bit CRC as specified in clause 6.1.3.

7.6.4 Channel coding & rate matching

Each of the code block segments are individually channel coded and rate matched as specified in clause 6.1.4 and clause 6.1.5. All non-HARQ transmissions shall use redundancy version index $rv_{idx} = 0$.

7.6.5 Code block concatenation

Code block segments are concatenated according to clause 6.1.6.

7.6.6 Scrambling

The channel encoded bits f_0, f_1, \dots, f_{G-1} , where $G = N_{ss} \cdot N_{subc}^{PDC} \cdot N_{bps}$ shall be scrambled with a sequence prior to CRC attachment, resulting in a block of scrambled bits:

$$d(i) = (f(i) + g(i)) \bmod 2$$

where the scrambling sequence $g(i)$ is given by clause 6.2.

If transmission is using Physical Layer Control Field: Type as specified in ETSI TS 103 636-4 [3], clause 6.2 the scrambling sequence shall be initialized with 24 MSB bits of the NetworkID ETSI TS 103 636-4 [3], clause 4.2.3:

$$g_{init} = (\text{Network ID} \gg 8) | 0x00ffffff$$

If transmission is using Physical Layer Control Field: Type 1 ETSI TS 103 636-4 [3], clause 6.2 the scrambling sequence shall be initialized with 8 LSB bits of the Network ID ETSI TS 103 636-4 [3], clause 4.2.3:

$$g_{init} = \text{Network ID} | 0x000000ff$$

7.6.7 Symbol mapping

Bit sequence by d_0, d_1, \dots, d_{G-1} is mapped into complex valued modulation symbols x_0, x_1, \dots, x_{S-1} as defined in clause 6.3.1 according to the MCS selected for the transport block. The length of the modulated symbol vector is $S = N_{subc}^{PDC} \cdot N_{SS}$.

7.6.8 Spatial multiplexing

Modulated symbols x_0, x_1, \dots, x_{S-1} are mapped to spatial streams $x_i^{(0)}, \dots, x_i^{(N_{SS}-1)}$ according to clause 6.3.2 for the selected transmission mode, where $S = N_{subc}^{PDC} \cdot N_{SS}$ and $i = 0, \dots, N_{subc}^{PDC} - 1$.

7.6.9 Transmit stream mapping

Modulated symbols from spatial stream mapping $x_i^{(0)}, \dots, x_i^{(N_{SS}-1)}$ are precoded to $y_i^{(0)}, \dots, y_i^{(N_{TS}-1)}$ according to the transmission mode, where N_{TS} is the number of transmit streams and $i = 0, \dots, N_{subc}^{PDC} - 1$.

For single antenna transmission the mapping is specified in clause 6.3.3.1.

For transmit diversity transmission is precoded is specified in clause 6.3.3.2.

For spatially multiplexed transmissions the mapping is specified in clause 6.3.3.1.

7.6.10 Beamforming and antenna port mapping

The modulated symbols $y_i^{(t)}$, $i = 0, \dots, N_{subc}^{PDC}$ from transmit streams $t = 0, \dots, N_{TS} - 1$ are beamformed according to the transmit mode as specified in clause 6.3.4 to produce PDC transmission $z_i^{(p)}$, $i = 0, \dots, N_{subc}^{PDC}$ on antenna ports $p = 0, \dots, N_{TX} - 1$.

7.6.11 Subcarrier mapping

Beamformed symbols $z_i^{(p)}$, $i = 0, \dots, N_{subc}^{PDC}$, $p = 0, \dots, N_{TX} - 1$ are mapped into N_{subc}^{PDC} subcarriers as defined in clause 5.2.5.

Annex A (normative): Modulation and coding schemes

Modulation and coding schemes are listed in table A-1, where N_{bps} denotes the number of bits per modulation symbol and R denotes the coding rate.

Table A-1: Modulation and coding schemes

MCS Index	Modulation	N_{bps}	R
0	BPSK	1	1/2
1	QPSK	2	1/2
2	QPSK	2	3/4
3	16-QAM	4	1/2
4	16-QAM	4	3/4
5	64-QAM	6	2/3
6	64-QAM	6	3/4
7	64-QAM	6	5/6
8	256-QAM	8	3/4
9	256-QAM	8	5/6
10	1024-QAM	10	3/4
11	1024-QAM	10	5/6

Annex B (normative): Physical layer requirements for radio device classes

B.1 Introduction

Radio device class shall be defined with tuple (μ, β, N_{SS}, A) for subcarrier scaling factor, Fourier transform scaling, number of spatial streams. In addition to first three fields, in the fourth field of the tuple encodes a device class variant with a letter A, B, ... etc. restricting the supported modulation and coding schemes and MAC capabilities. Capabilities of lower device category shall be supported by higher device category individually in all dimensions of the device category definition except in the first " μ " dimension.

B.2 Radio device class $(\mu, \beta, N_{SS}, A) = (1.1.1.A)$

B.2.1 Transmission bandwidth

Device shall support subcarrier scaling factor $\mu = 1$ and Fourier transform scaling factor $\beta = 1$. See clause 4.3.

B.2.2 Transmission modes

Device shall support all transmission modes that can be received with single transmission antenna. See clause 7.2.

B.2.3 Modulation and coding scheme

B.2.3.1 Modulation and coding

Device shall support MCS from 0 to 4. See annex A.

B.2.3.2 Hybrid ARQ processes

Device shall support at least $M_{DL_HARQ} = 8$ HARQ processes with at least $M_{DL_HARQ}^{connection} = 2$ processes per connection. See clause 6.1.5.

B.2.3.3 Soft buffer size

Device shall support $N_{soft} = 25\ 344$ byte soft buffer size. See clause 6.1.5.

B.2.3.4 Code block segment size

Device shall support maximum code block size $Z = 2\ 048$. See clause 6.1.3.

Annex C (informative): Transport block sizes and maximum achievable data rates

C.1 Single slot transmission, single spatial stream

Table C.1-1: Transport block sizes for single slot transmission and single spatial stream with maximum turbo code block size of 2 048 bits

TRANSPORT BLOCK SIZES	μ	$\beta \backslash \text{MCS}$	0	1	2	3	4	5	6	7	8	9	10	11
	1	1	136	296	456	616	936	1 256	1 416	1 576	1 896	2 040	2 296	2 552
		2	344	712	1 064	1 448	2 104	2 872	3 256	3 576	4 320	4 832	5 408	6 048
		4	760	1 544	2 296	3 064	4 640	6 152	6 984	7 752	9 328	10 328	11 672	12 928
		8	1 576	3 128	4 768	6 344	9 584	12 800	14 440	16 040	19 256	21 408	24 136	26 776
		12	2 360	4 832	7 240	9 712	14 568	19 448	21 920	24 368	29 248	32 464	36 576	40 624
		16	3 192	6 472	9 776	12 992	19 576	26 096	29 376	32 656	39 176	43 544	49 040	54 496
	2	1	368	760	1 160	1 544	2 296	3 064	3 512	3 896	4 640	5 216	5 856	6 472
		2	808	1 640	2 424	3 256	4 960	6 600	7 496	8 304	9 968	11 096	12 480	13 888
		4	1 704	3 384	5 088	6 792	10 264	13 696	15 464	17 168	20 576	22 920	25 776	28 608
		8	3 448	6 920	10 392	13 888	20 896	27 864	31 400	34 872	41 840	46 528	52 344	58 160
		12	5 216	10 456	15 720	20 960	31 528	42 032	47 336	52 600	63 080	70 112	78 912	87 888
16		6 984	14 016	21 024	28 056	42 160	56 200	63 272	70 304	84 344	93 760	105 456	117 176	
4	1	904	1 832	2 680	3 640	5 472	7 304	8 176	9 136	10 968	12 160	13 760	15 272	
	2	1 864	3 704	5 600	7 496	11 288	15 016	16 912	18 808	22 600	25 136	28 248	31 400	
	4	3 768	7 560	11 416	15 208	22 856	30 504	34 384	38 176	45 824	50 936	57 328	63 720	
	8	7 624	15 336	23 048	30 696	46 144	61 504	69 216	76 928	92 312	102 624	115 448	128 232	
	12	11 480	23 048	34 616	46 208	69 344	92 504	104 072	115 640	138 800	154 224	173 528	192 808	
	16	15 400	30 824	46 272	61 696	92 632	123 480	138 992	154 416	185 288	205 912	231 648	257 384	
8	1	1 928	3 832	5 792	7 688	11 608	15 464	17 424	19 384	23 240	25 840	29 120	32 360	
	2	3 896	7 816	11 736	15 656	23 560	31 400	35 384	39 304	47 144	52 408	58 968	65 552	
	4	7 880	15 784	23 688	31 592	47 464	63 272	71 240	79 144	94 976	105 520	118 752	131 960	
	8	15 848	31 720	47 592	63 464	95 272	127 040	142 976	158 848	190 592	211 792	238 296	264 800	
	12	23 816	47 656	71 496	95 336	143 104	190 784	214 688	238 552	286 232	318 040	357 840	397 616	
	16	31 784	63 592	95 400	127 232	190 912	254 552	286 424	318 232	381 872	424 312	477 384	530 432	

Table C.1-2: Single channel maximum throughput with single spatial stream with maximum turbo code block size of 2 048 bits

		μ	$\beta \backslash \text{MCS}$	0	1	2	3	4	5	6	7	8	9	10	11
				0	1	2	3	4	5	6	7	8	9	10	11
DATARATE (Mbps)	1	1		0,326	0,710	1,094	1,478	2,246	3,014	3,398	3,782	4,550	4,896	5,510	6,125
		2		0,826	1,709	2,554	3,475	5,050	6,893	7,814	8,582	10,368	11,597	12,979	14,515
		4		1,824	3,706	5,510	7,354	11,136	14,765	16,762	18,605	22,387	24,787	28,013	31,027
		8		3,782	7,507	11,443	15,226	23,002	30,720	34,656	38,496	46,214	51,379	57,926	64,262
		12		5,664	11,597	17,376	23,309	34,963	46,675	52,608	58,483	70,195	77,914	87,782	97,498
		16		7,661	15,533	23,462	31,181	46,982	62,630	70,502	78,374	94,022	104,506	117,696	130,790
	2	1		0,883	1,824	2,784	3,706	5,510	7,354	8,429	9,350	11,136	12,518	14,054	15,533
		2		1,939	3,936	5,818	7,814	11,904	15,840	17,990	19,930	23,923	26,630	29,952	33,331
		4		4,090	8,122	12,211	16,301	24,634	32,870	37,114	41,203	49,382	55,008	61,862	68,659
		8		8,275	16,608	24,941	33,331	50,150	66,874	75,360	83,693	100,416	111,667	125,626	139,584
		12		12,518	25,094	37,728	50,304	75,667	100,877	113,606	126,240	151,392	168,269	189,389	210,451
		16		16,762	33,638	50,458	67,334	101,184	134,880	151,853	168,730	202,426	225,024	253,094	281,222
	4	1		2,170	4,397	6,432	8,736	13,133	17,530	19,622	21,926	26,323	29,184	33,024	36,653
		2		4,474	8,890	13,440	17,990	27,091	36,038	40,589	45,139	54,240	60,326	67,795	75,360
		4		9,043	18,144	27,398	36,499	54,854	73,210	82,522	91,622	109,978	122,246	137,587	152,928
		8		18,298	36,806	55,315	73,670	110,746	147,610	166,118	184,627	221,549	246,298	277,075	307,757
12			27,552	55,315	83,078	110,899	166,426	222,010	249,773	277,536	333,120	370,138	416,467	462,739	
16			36,960	73,978	111,053	148,070	222,317	296,352	333,581	370,598	444,691	494,189	555,955	617,722	
8	1		4,627	9,197	13,901	18,451	27,859	37,114	41,818	46,522	55,776	62,016	69,888	77,664	
	2		9,350	18,758	28,166	37,574	56,544	75,360	84,922	94,330	113,146	125,779	141,523	157,325	
	4		18,912	37,882	56,851	75,821	113,914	151,853	170,976	189,946	227,942	253,248	285,005	316,704	
	8		38,035	76,128	114,221	152,314	228,653	304,896	343,142	381,235	457,421	508,301	571,910	635,520	
	12		57,158	114,374	171,590	228,806	343,450	457,882	515,251	572,525	686,957	763,296	858,816	954,278	
	16		76,282	152,621	228,960	305,357	458,189	610,925	687,418	763,757	916,493	1 018,349	1 145,722	1 273,037	

Table C.1-3: Transport block sizes for single slot transmission and single spatial stream with maximum turbo code block size of 6 144 bits

		μ	$\beta \backslash \text{MCS}$	0	1	2	3	4	5	6	7	8	9	10	11
				0	1	2	3	4	5	6	7	8	9	10	11
TRANSPORT BLOCK SIZES	1	1		136	296	456	616	936	1 256	1 416	1 576	1 896	2 088	2 344	2 600
		2		344	712	1 064	1 448	2 152	2 920	3 304	3 624	4 392	4 904	5 480	6 096
		4		760	1 544	2 344	3 112	4 712	6 200	7 032	7 800	9 400	10 424	11 768	13 024
		8		1 576	3 176	4 840	6 392	9 656	12 896	14 560	16 160	19 400	21 576	24 328	26 992
		12		2 408	4 904	7 288	9 784	14 688	19 592	22 088	24 560	29 488	32 728	36 864	40 960
		16		3 240	6 520	9 848	13 088	19 720	26 288	29 616	32 920	39 488	43 880	49 424	54 928
	2	1		368	760	1 160	1 544	2 344	3 112	3 560	3 944	4 712	5 288	5 928	6 520
		2		808	1 640	2 472	3 304	5 032	6 648	7 544	8 376	10 040	11 192	12 576	13 984
		4		1 704	3 432	5 160	6 840	10 360	13 792	15 584	17 312	20 744	23 112	25 968	28 848
		8		3 496	6 968	10 488	13 984	21 064	28 080	31 640	35 160	42 176	46 888	52 752	58 616
		12		5 288	10 552	15 840	21 128	31 768	42 368	47 720	53 008	63 584	70 664	79 536	88 384
		16		7 032	14 112	21 192	28 272	42 496	56 632	63 776	70 856	85 016	94 504	106 296	118 088
	4	1		904	1 832	2 728	3 688	5 544	7 352	8 248	9 208	11 064	12 256	13 856	15 392
		2		1 864	3 752	5 672	7 544	11 384	15 136	17 056	18 952	22 792	25 328	28 464	31 640
		4		3 816	7 608	11 512	15 328	23 048	30 744	34 648	38 464	46 184	51 344	57 784	64 224
		8		7 672	15 456	23 240	30 936	46 504	61 984	69 768	77 552	93 032	103 440	116 360	129 240
12			11 576	23 240	34 904	46 568	69 896	93 224	104 888	116 552	139 904	155 448	174 896	194 344	
16			15 520	31 064	46 632	62 176	93 352	124 464	140 096	155 640	186 752	207 544	233 472	259 424	
8	1		1 928	3 880	5 864	7 736	11 704	15 584	17 568	19 528	23 432	26 032	29 360	32 600	
	2		3 944	7 864	11 832	15 776	23 752	31 640	35 672	39 616	47 528	52 816	59 448	66 080	
	4		7 928	15 904	23 880	31 832	47 848	63 776	71 816	79 768	95 720	106 360	119 688	133 016	
	8		15 968	31 960	47 976	63 968	96 040	128 048	144 104	160 096	192 104	213 472	240 168	266 888	
	12		24 008	48 040	72 072	96 104	144 232	192 296	216 392	240 424	288 488	320 560	360 672	400 760	
	16		32 024	64 096	96 168	128 240	192 424	256 568	288 680	320 752	384 896	427 672	481 152	534 632	

Table C.1-4: Single channel maximum throughput with single spatial stream with maximum turbo code block size of 6 144 bits

DATARATE (Mbps)	μ	$\beta \backslash \text{MCS}$	0	1	2	3	4	5	6	7	8	9	10	11
			1	0,326	0,710	1,094	1,478	2,246	3,014	3,398	3,782	4,550	5,011	5,626
2	0,826	1,709	2,554	3,475	5,165	7,008	7,930	8,698	10,541	11,770	13,152	14,630		
4	1,824	3,706	5,626	7,469	11,309	14,880	16,877	18,720	22,560	25,018	28,243	31,258		
8	3,782	7,622	11,616	15,341	23,174	30,950	34,944	38,784	46,560	51,782	58,387	64,781		
12	5,779	11,770	17,491	23,482	35,251	47,021	53,011	58,944	70,771	78,547	88,474	98,304		
16	7,776	15,648	23,635	31,411	47,328	63,091	71,078	79,008	94,771	105,312	118,618	131,827		
2	0,883	1,824	2,784	3,706	5,626	7,469	8,544	9,466	11,309	12,691	14,227	15,648		
4	1,939	3,936	5,933	7,930	12,077	15,955	18,106	20,102	24,096	26,861	30,182	33,562		
8	4,090	8,237	12,384	16,416	24,864	33,101	37,402	41,549	49,786	55,469	62,323	69,235		
12	8,390	16,723	25,171	33,562	50,554	67,392	75,936	84,384	101,222	112,531	126,605	140,678		
16	12,691	25,325	38,016	50,707	76,243	101,683	114,528	127,219	152,602	169,594	190,886	212,122		
4	2,170	4,397	6,547	8,851	13,306	17,645	19,795	22,099	26,554	29,414	33,254	36,941		
8	4,474	9,005	13,613	18,106	27,322	36,326	40,934	45,485	54,701	60,787	68,314	75,936		
12	9,158	18,259	27,629	36,787	55,315	73,786	83,155	92,314	110,842	123,226	138,682	154,138		
16	18,413	37,094	55,776	74,246	111,610	148,762	167,443	186,125	223,277	248,256	279,264	310,176		
8	27,782	55,776	83,770	111,763	167,750	223,738	251,731	279,725	335,770	373,075	419,750	466,426		
16	37,248	74,554	111,917	149,222	224,045	298,714	336,230	373,536	448,205	498,106	560,333	622,618		
8	4,627	9,312	14,074	18,566	28,090	37,402	42,163	46,867	56,237	62,477	70,464	78,240		
12	9,466	18,874	28,397	37,862	57,005	75,936	85,613	95,078	114,067	126,758	142,675	158,592		
16	19,027	38,170	57,312	76,397	114,835	153,062	172,358	191,443	229,728	255,264	287,251	319,238		
8	38,323	76,704	115,142	153,523	230,496	307,315	345,850	384,230	461,050	512,333	576,403	640,531		
12	57,619	115,296	172,973	230,650	346,157	461,510	519,341	577,018	692,371	769,344	865,613	961,824		
16	76,858	153,830	230,803	307,776	461,818	615,763	692,832	769,805	923,750	1 026,413	1 154,765	1 283,117		

History

Document history		
V1.1.1	July 2020	Publication