

ETSI TS 103 287 V1.1.1 (2014-09)



TECHNICAL SPECIFICATION

**Digital Video Broadcasting (DVB);
Modulator Interface (C2-MI) for a second generation digital
transmission system for cable systems (DVB-C2)**

EBU
OPERATING EUROVISION

DVB[®]
Digital Video
Broadcasting

Reference

DTS/JTC-DVB-345

Keywords

DVB, broadcasting

ETSI

650 Route des Lucioles
F-06921 Sophia Antipolis Cedex - FRANCE

Tel.: +33 4 92 94 42 00 Fax: +33 4 93 65 47 16

Siret N° 348 623 562 00017 - NAF 742 C
Association à but non lucratif enregistrée à la
Sous-Préfecture de Grasse (06) N° 7803/88

Important notice

The present document can be downloaded from:

<http://www.etsi.org>

The present document may be made available in electronic versions and/or in print. The content of any electronic and/or print versions of the present document shall not be modified without the prior written authorization of ETSI. In case of any existing or perceived difference in contents between such versions and/or in print, the only prevailing document is the print of the Portable Document Format (PDF) version kept on a specific network drive within ETSI Secretariat.

Users of the present document should be aware that the document may be subject to revision or change of status. Information on the current status of this and other ETSI documents is available at

<http://portal.etsi.org/tb/status/status.asp>

If you find errors in the present document, please send your comment to one of the following services:

http://portal.etsi.org/chaicor/ETSI_support.asp

Copyright Notification

No part may be reproduced or utilized in any form or by any means, electronic or mechanical, including photocopying and microfilm except as authorized by written permission of ETSI.

The content of the PDF version shall not be modified without the written authorization of ETSI.

The copyright and the foregoing restriction extend to reproduction in all media.

© European Telecommunications Standards Institute 2014.

© European Broadcasting Union 2014.

All rights reserved.

DECT™, **PLUGTESTS™**, **UMTS™** and the ETSI logo are Trade Marks of ETSI registered for the benefit of its Members.

3GPP™ and **LTE™** are Trade Marks of ETSI registered for the benefit of its Members and of the 3GPP Organizational Partners.

GSM® and the GSM logo are Trade Marks registered and owned by the GSM Association.

Contents

Intellectual Property Rights	4
Foreword.....	4
Modal verbs terminology.....	4
Introduction	5
1 Scope	6
2 References	6
2.1 Normative references	6
2.2 Informative references.....	6
3 Definitions, symbols and abbreviations	7
3.1 Definitions.....	7
3.2 Symbols.....	7
3.3 Abbreviations	8
4 Overview	9
4.1 The DVB-C2 Modulator Interface concept	9
4.2 The protocol stack for DVB-C2 distribution in backbone distribution systems	9
5 Framing structure	10
5.1 Symbol related TDM structure	10
5.2 Frame related TDM structure	13
6 Signalling in the symbol header	13
7 DVB-C2 MI transmission, payload and overhead capacity per 8 MHz channel.....	17
8 Transport of C2-MI packets	17
8.1 Encapsulation of C2-MI packets in MPEG-2 TS	17
8.1.1 Description.....	17
8.2 Encapsulation of MPEG-2 TS in IP packets.....	18
8.2.1 Setup Information	18
8.2.2 Transport protocols	19
8.2.3 Session initiation and control.....	20
8.2.4 Network requirements.....	20
Annex A (normative): Calculation of the CRC word	21
Annex B (informative): Examples for the usage of the C2 Modulator Interface	22
B.1 Example of a C2 Modulator Interface configuration for a C2 System in a single PLP/single Data Slice (Type 1) configuration with 8 MHz RF bandwidth.....	22
B.2 Example of a C2 Modulator Interface configuration for a C2 System with 8 MHz RF bandwidth and a multiple PLPs/Data Slices configuration.....	23
B.3 Example of a C2 Modulator Interface configuration for a C2 System with 22 MHz RF band and a Broadband notch	24
Annex C (informative): Labeling of C2 Modulator Interface (C2-MI) devices.....	27
Annex D (informative): Bibliography	28
History	29

Intellectual Property Rights

IPRs essential or potentially essential to the present document may have been declared to ETSI. The information pertaining to these essential IPRs, if any, is publicly available for **ETSI members and non-members**, and can be found in ETSI SR 000 314: "*Intellectual Property Rights (IPRs); Essential, or potentially Essential, IPRs notified to ETSI in respect of ETSI standards*", which is available from the ETSI Secretariat. Latest updates are available on the ETSI Web server (<http://ipr.etsi.org>).

Pursuant to the ETSI IPR Policy, no investigation, including IPR searches, has been carried out by ETSI. No guarantee can be given as to the existence of other IPRs not referenced in ETSI SR 000 314 (or the updates on the ETSI Web server) which are, or may be, or may become, essential to the present document.

Foreword

This Technical Specification (TS) has been produced by Joint Technical Committee (JTC) Broadcast of the European Broadcasting Union (EBU), Comité Européen de Normalisation ELECTrotechnique (CENELEC) and the European Telecommunications Standards Institute (ETSI).

NOTE: The EBU/ETSI JTC Broadcast was established in 1990 to co-ordinate the drafting of standards in the specific field of broadcasting and related fields. Since 1995 the JTC Broadcast became a tripartite body by including in the Memorandum of Understanding also CENELEC, which is responsible for the standardization of radio and television receivers. The EBU is a professional association of broadcasting organizations whose work includes the co-ordination of its members' activities in the technical, legal, programme-making and programme-exchange domains. The EBU has active members in about 60 countries in the European broadcasting area; its headquarters is in Geneva.

European Broadcasting Union
CH-1218 GRAND SACONNEX (Geneva) Switzerland
Tel: +41 22 717 21 11
Fax: +41 22 717 24 81

The Digital Video Broadcasting Project (DVB) is an industry-led consortium of broadcasters, manufacturers, network operators, software developers, regulatory bodies, content owners and others committed to designing global standards for the delivery of digital television and data services. DVB fosters market driven solutions that meet the needs and economic circumstances of broadcast industry stakeholders and consumers. DVB standards cover all aspects of digital television from transmission through interfacing, conditional access and interactivity for digital video, audio and data. The consortium came together in 1993 to provide global standardization, interoperability and future proof specifications.

Modal verbs terminology

In the present document "**shall**", "**shall not**", "**should**", "**should not**", "**may**", "**may not**", "**need**", "**need not**", "**will**", "**will not**", "**can**" and "**cannot**" are to be interpreted as described in clause 3.2 of the [ETSI Drafting Rules](#) (Verbal forms for the expression of provisions).

"**must**" and "**must not**" are **NOT** allowed in ETSI deliverables except when used in direct citation.

Introduction

Many cable operators today use centralized master headends, whereas most of the digital signal processing is performed. Often glass fiber based backbone networks then distribute already finally multiplexed MPEG **Transport Streams** to the local headend stations, where the final channel lineup is defined by combining network-wide identical signals with the relevant local content. All signals are digitally DVB-C modulated, converted to the RF frequency range and then distributed via the coaxial cable section of the cable infrastructure to the cable end customers. This architecture is called HFC (Hybrid Fiber Coax). Digital modulation of the second generation (DVB-C2) is more complex and provides more flexibility than the first generation (DVB-C) technology. The C2 Modulator Interface allows splitting the DVB-C2 modulation functionality into a centralized part with the more complex digital processing functionalities and a quite simple decentralized part, which will be implemented in the local headends or even fiber nodes. The major advantage of such solution is twofold. There is on the one hand cost saving as the more complex part has to be implemented only once in the master headend and is shared for all local headends. On the other hand the operation of the centralized components can be handled better and more efficient at the 24/7 staffed centralized master headends than in hundreds of local headends, which are usually not staffed and only remote managed. The C2 Modulator Interface will allow significant cost saving potential for cable operators running a HFC type network. The savings are obvious for TV services which are distributed to all network segments. For local TV services, which are distributed only within one segment of a network, a local DVB-C2 modulator is most likely the commercial attractive solution. However, cable operators may decide to use the C2 MI even in this application in case they want run all signal processing (encoding Multiplexing and modulation) in their master headend mainly for operational reasons.

1 Scope

The present document defines the interface to a modulator for a second generation cable television system (DVB-C2). This document also describes a mechanism to distribute DVB-C2 modulated signals in the backbone distribution segment of cable networks in a cost effective way.

2 References

References are either specific (identified by date of publication and/or edition number or version number) or non-specific. For specific references, only the cited version applies. For non-specific references, the latest version of the reference document (including any amendments) applies.

Referenced documents which are not found to be publicly available in the expected location might be found at <http://docbox.etsi.org/Reference>.

NOTE: While any hyperlinks included in this clause were valid at the time of publication, ETSI cannot guarantee their long term validity.

2.1 Normative references

The following referenced documents are necessary for the application of the present document.

- [1] ETSI EN 302 769: "Digital Video Broadcasting (DVB); Frame structure channel coding and modulation for a second generation digital transmission system for cable systems (DVB-C2)".
- [2] ETSI EN 301 192: "Digital Video Broadcasting (DVB); DVB specification for data broadcasting".
- [3] ETSI TS 102 034: "Digital Video Broadcasting (DVB); Transport of MPEG-2 TS Based DVB Services over IP Based Networks".
- [4] IETF RFC 3550: "RTP: A Transport Protocol for Real-Time Applications".
- [5] ISO/IEC 13818-1: "Information technology - Generic coding of moving pictures and associated audio information: Systems".
- [6] ETSI EN 300 468: "Digital Video Broadcasting (DVB); Specification for Service Information (SI) in DVB systems".

2.2 Informative references

The following referenced documents are not necessary for the application of the present document but they assist the user with regard to a particular subject area.

- [i.1] EN 50083-9: "Cabled distribution systems for television, sound and interactive multimedia signals; Part 9: Interfaces for CATV/SMATV headends and similar professional equipment for DVB/MPEG-2 transport streams" (DVB Blue Book A010)".
- [i.2] DVB BlueBook A115: "DVB Application Layer FEC Evaluations".

3 Definitions, symbols and abbreviations

3.1 Definitions

For the purposes of the present document, the following terms and definitions apply:

broadband notch: set of adjacent OFDM Cells within each OFDM Symbol without transmitted energy, as defined in EN 302 769 [1]

C2 frame: fixed physical layer TDM frame that is further divided into variable size **Data Slices**

NOTE: C2 Frame starts with one or more **Preamble symbol**.

C2 system: complete transmitted DVB-C2 signal, as defined in EN 302 769 [1]

C2_System_ID: unique identifier of a C2 system in a cable network as defined in EN 302 769 [1]

centre frequency: absolute frequency of the subcarrier, which is in the middle between the lowest and the highest frequency subcarrier of a **C2 system**

data slice: group of OFDM Cells carrying one or multiple PLPs in a certain frequency sub-band

NOTE: This set consists of OFDM Cells within a fixed range of consecutive cell addresses within each Data Symbol and spans over the complete C2 Frame, except the **Preamble symbols**.

data symbol: OFDM symbol in a C2 Frame which is not a **preamble symbol**

future use: value of any field indicated as "Future use" shall be set to "0" unless otherwise defined

OFDM cell: modulation value for one OFDM carrier during one OFDM Symbol, e.g. a single constellation point

OFDM symbol: waveform Ts in duration comprising all the active carriers modulated with their corresponding modulation values and including the guard interval

Physical Layer Pipe (PLP): logical channel carried within one or multiple **Data Slice(s)**

NOTE 1: All signal components within a PLP share the same transmission parameters such as robustness, latency.

NOTE 2: A PLP may carry one or multiple services. In case of PLP Bundling a PLP may be carried in several **Data Slices**. Transmission parameters may change each XFECFrame.

preamble symbol: one or multiple OFDM Symbols, transmitted at the beginning of each C2 Frame, carrying Layer 1 part 2 signalling data

Transport Stream (TS): multiplex signal as defined in ISO/IEC MPEG Systems specification [5]

3.2 Symbols

For the purposes of the present document, the following symbols apply:

123	A number without prefix denotes a decimal integer (base 10)
0x123	A number with a "0x" prefix denotes a hexadecimal integer (base 16)
(1010) ₂	A number enclosed in parentheses, and with a number suffix denotes an integer to the base indicated by the suffix.

EXAMPLE: The representations for the number one-hundred and twenty three are: 123 to the base 10 (decimal), 0x7B to the base 16 (hexadecimal), and (1111011)₂ to the base 2 (binary).

NOTE: For binary and hexadecimal representations it may sometimes be convenient to group digits, and fill in leading zeroes to accommodate common word sizes. The number one-hundred and twenty three can hence for example also be represented as 0x007B, 0x0000 007B, (0111 1011)₂, or (0000 0000 0111 1011)₂.

3.3 Abbreviations

For the purposes of the present document, the following abbreviations apply:

1 024-QAM	1 024-ary Quadrature Amplitude Modulation
16-QAM	16-ary Quadrature Amplitude Modulation
256-QAM	256-ary Quadrature Amplitude Modulation
4 096-QAM	4 096-ary Quadrature Amplitude Modulation
64-QAM	64-ary Quadrature Amplitude Modulation
8PSK	8-ary Phase Shift Keying
ASI	Asynchronous Serial Interface
CATV	Community Antenna Television
CRC	Cyclic Redundancy Check
dB	decibel
DBPSK	Differential Binary Phase Shift Keying
DVB	Digital Video Broadcasting project
DVB-C2	DVB-C2 System

NOTE: As specified in EN 302 769 [1].

FEC	Forward Error Correction
GI	Guard Interval
GS	Generic Stream
GSE	Generic Stream Encapsulation
HFC	Hybrid Fibre Coax
IP	Internet Protocol
Kbit	$2^{10} = 1\,024$ bits
LSB	Least Significant Bit
Mbit	$2^{20} = 1\,048\,576$ bits
Mbit/s	Mbit per second
MI	Modulation Interface
MPEG	Moving Pictures Experts Group
MSB	Most Significant Bit

NOTE: In DVB-C2 MI the MSB is always transmitted first.

OFDM	Orthogonal Frequency Division Multiplex
PAPR	Peak to Average Power Ratio
PAT	Program Association Table
PID	Packet Identifier
PLP	Physical Layer Pipe
PMT	Program Map Table
PRBS	Pseudo Random Binary Sequence
PSI	Program Specific Information
QAM	Quadrature Amplitude Modulation
QoS	Quality of Service
QPSK	Quaternary Phase Shift Keying
RF	Radio Frequency
RTCP	Real-Time Transport Control Protocol
RTP	Real Time Protocol
SI	Service Information
TDM	Time Division Multiplex
TS	Transport Stream
UDP	User Datagram Protocol
uimsbf	unsigned integer, most significant bit first
XOR	eXclusive OR function

4 Overview

4.1 The DVB-C2 Modulator Interface concept

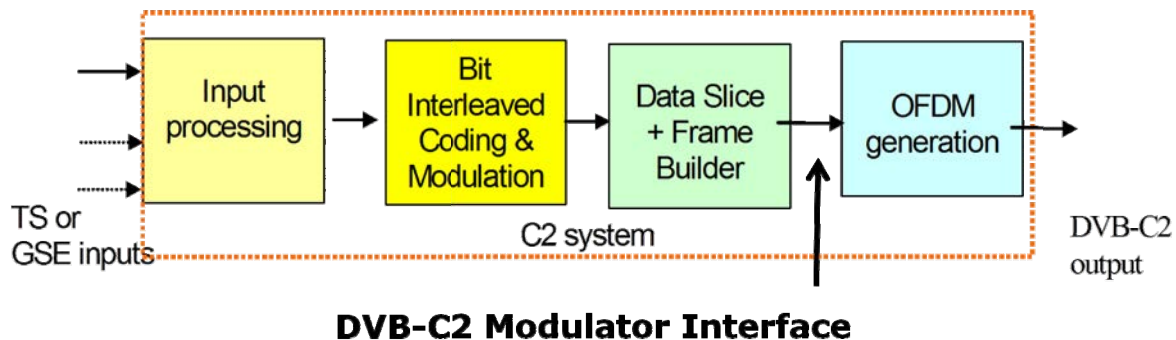

Figure 1: DVB-C2 modulator block diagram and location of the DVB-C2 Modulator Interface

The concept of the DVB-C2 Modulator Interface (C2-MI) is to define an interface at the output of the Data Slice and Frame Builder of a DVB-C2 modulator and to map this data structure into a specific Time Division Multiplexing (TDM) structure. The location of the DVB-C2 modulator interface within the modulator block diagram is shown in Figure 1.

The C2-MI concept accordingly provides an interface between a centralized "server" part, which comprises the large majority of the technical complexity, and an arbitrary number of connected low complexity "clients".

The "server" part of a C2-MI compliant DVB-C2 modulator covers all complex input-, **PLP**-, **Data Slice**-, L1-signalling- and framing-processing and provides an interface with the TDM structure.

The "client"-part of the C2-MI compliant modulator needs only to decode the TDM structure and to perform the OFDM generation, therefore allowing for low cost edge-modulators.

The TDM structure needs to be very flexible in order to cover all scenarios foreseen in the DVB-C2 specification. It has to support especially the variation of the following parameters:

- The modulation schemes of the data cells may vary from 16-QAM to 4 096-QAM. The modulation scheme of a PLP may vary on a frame by frame basis (adaptive coding and modulation application) and it may be different for each transmitted PLP due to the "service related QoS"-feature.
- The bandwidth of a **C2 system** is minimum 8 MHz but can theoretically go up to about 450 MHz. Especially UltraHD type of services will require broader transmission channels in the future.
- Broadband notches may be located within the modulator RF bandwidth.

The TDM structure provides additional data elements, allowing the receiver to synchronize and to properly detect the transmission parameters of the **C2 system**.

Whenever in this document reference is made to a **C2 system** with 8 MHz minimum bandwidth, this is related to the solution with a subcarrier spacing of 2,232 kHz as defined in clause 10.1 of EN 302 769 [1]. The DVB-C2 Modulator Interface can also be applied to systems with a minimum bandwidth of 6 MHz, corresponding to a subcarrier spacing of 1,674 kHz as defined in clause 10.1 of EN 301 192 [2]. In both cases the minimum number of subcarriers per **C2 system** is 3 409, accordingly the multiplexing structures defined hereafter are applicable to both 6 MHz and 8 MHz minimum bandwidth variants of the DVB-C2 system.

4.2 The protocol stack for DVB-C2 distribution in backbone distribution systems

Figure 2 shows the DVB-C2 Modulator Interface protocol stack.

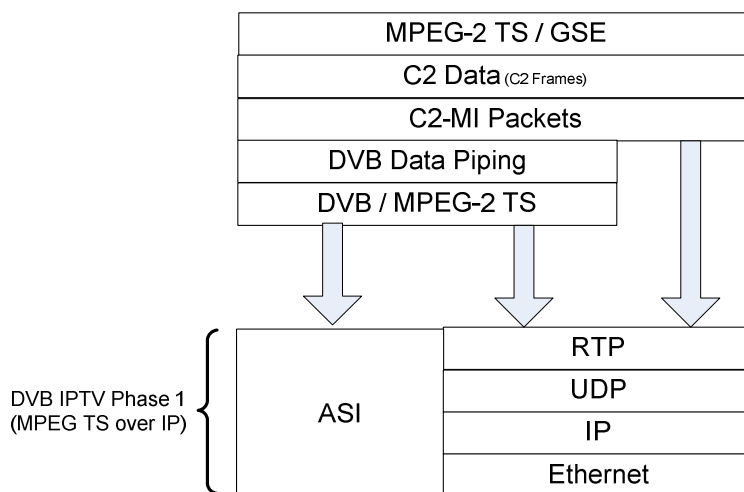

Figure 2: The DVB-C2-Modulator Interface protocol stack

The C2 Modulator Interface (C2-MI) carries the complete payload of a DVB-C2 frame.

The C2 frame payload data is packetized into C2-MI packets and encapsulated into DVB/MPEG **Transport Stream** packets using Data Piping, in accordance with EN 301 192 [2], clause 4.

These standard DVB TS packets are then carried either natively over any standard DVB **Transport Stream** interface, such as ASI, or further encapsulated within IP packets in accordance with TS 102 034 [3] for carriage over IP based networks.

Furthermore there is a simplified IP transport mechanism available, which skips the DVB Data Piping and the mapping into MPEG-2 **Transport Stream** packets.

5 Framing structure

The DVB-C2 Modulator Interface TDM structure represents the DVB-C2 framing structure. The payload of all symbols of a frame is transmitted in a time division multiplexing scheme.

5.1 Symbol related TDM structure

The TDM structure, which carries the payload data of a DVB-C2 symbol, is structured as shown in table 1.

Table 1: TDM structure for the transport of the payload data of a DVB-Cs symbol via the DVB-C2 modulator interface

C2-MI Packet								CRC
Horizontal Sync field	payload-fields							CRC
Horizontal Sync field	First payload field			Last payload field			32 bit
Horizontal Sync field	Mode	I-Field	Q-Field	Mode	I-field	Q-field	32 bit
13 byte	1 bit	2-6 bit	2-6 bit	1 bit	2-6 bit	2-6 bit	32 bit

The overall length of the symbol multiplexing structure depends on the modulation schemes, but not on the chosen guard interval or the pilot density.

The length of the I- and Q-fields is constant for the modulator interface of a **C2 system** and fits with the maximum modulation scheme as given in the **Horizontal sync field**.

The Mode field, as defined in Table 2, indicates the modulation scheme for the individual payload subcarriers. It refers to the **MaxMod** field in the **Sync-field**.

Table 2: Definition of the Mode field

Mode-field (1 bit)	
$(0)_2$	The modulation schemes as indicated with the MaxMod field scheme is not used, but a lower order scheme
$(1)_2$	The modulation schemes as indicated with the MaxMod field is used

In case the Mode field is not set, the two MSB bits (one in the I-Field and one in the Q-field) are not required to deliver the relevant constellation. These two bits are now used to indicate the actual modulation scheme of the related subcarrier. If those two bits are both set to 11, the remaining bits of the I- and Q-Field represent the constellation one level below **MaxMod**. If those bits are both set to $(00)_2$, the relevant constellation is at least one further level lower than **MaxMod** and there are two further (again the MSB) bits no longer needed for indicating the relevant modulation constellation. If those additional bits are set to 11, the remaining bits of the I- and Q-Field represent the constellation two levels below **MaxMod**. If those bits are both set to $(00)_2$, the relevant constellation is at least one further level lower than **MaxMod**.

The following 4 tables (table 3 to table 7) show the different possible configurations of the payload fields for the different **MaxMod** modulation schemes.

Table 3: Encoding of the different modulation constellations in case of MaxMod is set to 4 096-QAM

MaxMod 4 096 QAM. 13 bit Mode-, I- and Q-field					
Mode-field	I-field		Q-field		Modulation
	control	data	control	data	
$(1)_2$	-	6-bit	-	6-bit	4 096-QAM
$(0)_2$	$(1)_2$	5-bit	$(1)_2$	5-bit	1 024-QAM
$(0)_2$	$(01)_2$	4-bit	$(01)_2$	4-bit	256-QAM
$(0)_2$	$(001)_2$	3-bit	$(001)_2$	3-bit	64-QAM
$(0)_2$	$(0001)_2$	2-bit	$(0001)_2$	2-bit	16-QAM
$(0)_2$	$(00001)_2$	1-bit	$(00001)_2$	1-bit	QPSK
$(0)_2$	$(00001)_2$	1-bit	$(000001)_2$	-	BPSK
$(0)_2$	$(000000)_2$	-	$(000000)_2$	-	Notch

Table 4: Encoding of the different modulation constellations in case of MaxMod is set to 1 024-QAM

MaxMod 1 024 QAM. 11 bit Mode-, I- and Q-field					
Mode-field	I-field		Q-field		Modulation
	Control	data	Control	data	
$(1)_2$	-	5-bit	-	5-bit	1 024-QAM
$(0)_2$	$(1)_2$	4-bit	$(1)_2$	4-bit	256-QAM
$(0)_2$	$(01)_2$	3-bit	$(01)_2$	3-bit	64-QAM
$(0)_2$	$(001)_2$	2-bit	$(001)_2$	2-bit	16-QAM
$(0)_2$	$(0001)_2$	1-bit	$(0001)_2$	1-bit	QPSK
$(0)_2$	$(0001)_2$	1-bit	$(00001)_2$	0-bit	BPSK
$(0)_2$	$(00000)_2$	-	$(00000)_2$	-	Notch

Table 5: Encoding of the different modulation constellations in case of MaxMod is set to 256-QAM

MaxMod 256 QAM. 9 bit Mode-, I- and Q-field					
Mode-field	I-field		Q-field		Modulation
	Control	data	Control	data	
$(1)_2$	-	4-bit	-	4-bit	256-QAM
$(0)_2$	$(1)_2$	3-bit	$(1)_2$	3-bit	64-QAM
$(0)_2$	$(01)_2$	2-bit	$(01)_2$	2-bit	16-QAM
$(0)_2$	$(001)_2$	1-bit	$(001)_2$	1-bit	QPSK
$(0)_2$	$(001)_2$	1-bit	$(0001)_2$	0-bit	BPSK
$(0)_2$	$(0000)_2$	0-bit	$(0000)_2$	0-bit	Notch

Table 6: Encoding of the different modulation constellations in case of MaxMod is set to 64-QAM

MaxMod 64 QAM. 7 bit Mode-, I- and Q-field					
Mode-field	I-field		Q-field		Modulation
	Control	data	Control	data	
$(1)_2$	-	3-bit	-	3-bit	64-QAM
$(0)_2$	$(1)_2$	2-bit	$(1)_2$	2-bit	16-QAM
$(0)_2$	$(01)_2$	1-bit	$(01)_2$	1-bit	QPSK
$(0)_2$	$(01)_2$	1-bit	$(001)_2$	0-bit	BPSK
$(0)_2$	$(000)_2$	0-bit	$(000)_2$	0-bit	Notch

Table 7: Encoding of the different modulation constellations in case of MaxMod is set to 16-QAM

MaxMod 16 QAM. 5 bit Mode-, I- and Q-field					
Mode-field	I-field		Q-field		Modulation
	control	data	control	data	
$(1)_2$	-	2-bit	-	2-bit	16-QAM
$(0)_2$	$(1)_2$	1-bit	$(1)_2$	1-bit	QPSK
$(0)_2$	$(1)_2$	1-bit	$(01)_2$	0-bit	BPSK
$(0)_2$	$(00)_2$	0-bit	$(00)_2$	0-bit	Notch

The I-/Q-fields have the length as indicated in table 8. The length is depending on the highest order of modulation used in this C2 System (MaxMod parameter).

Table 8: Length of the I-field and Q-field with respect to the MaxMod parameter

MaxMod	I-field	Q-field	Comment
set to 16-QAM: $(100)_2$	2 bit	2 bit	Total spectrum efficiency 4 bit/symbol
set to 64-QAM: $(001)_2$	3 bit	3 bit	Total spectrum efficiency 6 bit/symbol
set to 256-QAM: $(010)_2$	4 bit	4 bit	Total spectrum efficiency 8 bit/symbol
set to 1 024-QAM: $(011)_2$	5 bit	5 bit	Total spectrum efficiency 10 bit/symbol
set to 4 096-QAM: $(100)_2$	6 bit	6 bit	Total spectrum efficiency 12 bit/symbol

NOTE 1: The I-/Q-field has the following length, which is depending on the highest order of modulation used in this C2 System (MaxMod parameter).

NOTE 2: In case of pilots or PLPs with lower order modulation the I-/Q-fields might be shortened. However this would lead to a complicated multiplexing structure, which may be very sensitive in case of transmission errors. The simple structure has the clear advantage of higher robustness.

CRC (32 bits) is calculated across all other bits in the C2-MI Packet (both Horizontal Sync field and payload field), in accordance with annex A of the present document.

5.2 Frame related TDM structure

A DVB-C2 frame consists of one or multiple **preamble symbols** followed by 448 payload symbols. For the frame related TDM structure the symbol related TDM as discussed in clause 5.1, is applied accordingly. This configuration is shown in Figure 4. As the modulation scheme may vary per PLP and over time, this configuration is generally applicable for any application of the DVB-C2 system.

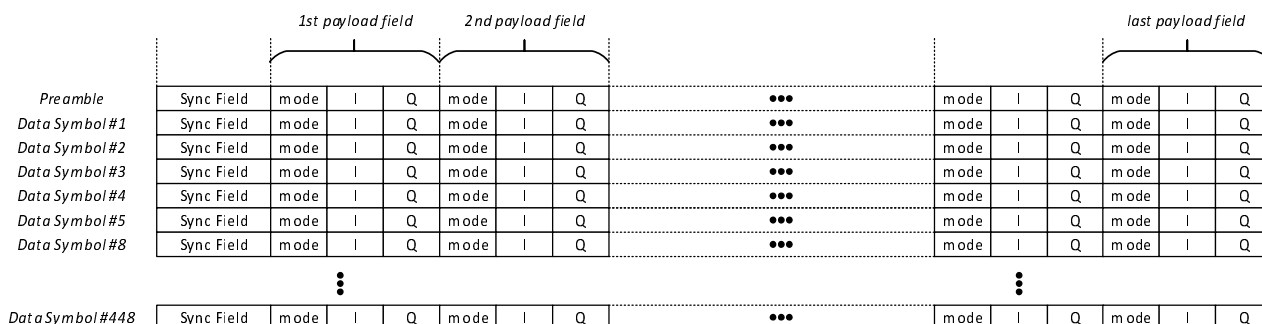

Figure 4: TDM frame structure for a configuration with variable modulation scheme for payload subcarriers

For single **Data Slice** (**Data Slice** type 1) and single PLP operation (where the same modulation is used for the whole payload of the C2 system), the following simplified TDM structure can be used:

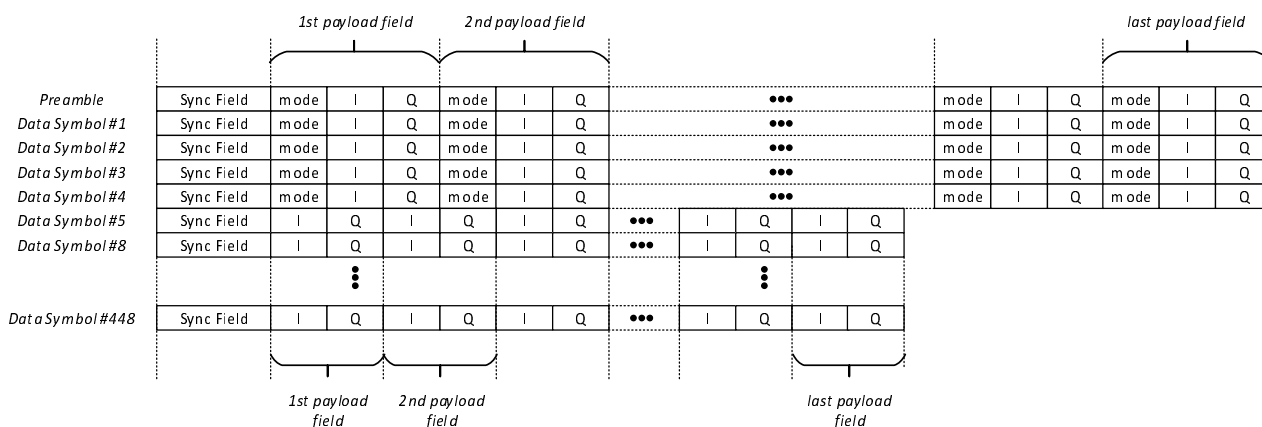

Figure 5: TDM structure for a configuration with constant modulation scheme for payload subcarriers

The TDM frame is created by concatenation of the symbols row by row. For the **preamble symbol(s)** and the first four data symbols within a frame the signaling of the modulation is required to differentiate between payload carriers, pilots and notches. The signaling of the modulation order can afterwards be omitted, due to the scattered pilot pattern repetition after 4 data symbols as well as the constant allocation of notches during a frame.

6 Signalling in the symbol header

The horizontal structure will start with a Sync/CRC field, as already mentioned in clause 3.

As the payload of the framing structure is the sequence of the modulation parameters of all subcarriers, this payload will vary significantly with the choice of the modulation scheme.

Each horizontal framing element will start with an identical sync-field defined as defined in table 9.

Table 9: Definition of the horizontal Sync field

Horizontal Sync-field												CRC
Syncword		Frame-counter	Symbol-Counter		Num Subcarrier		System-Config	Symbol-Para	C2_sytem_ID		MI-Version Number	CRC
1 byte	1 byte	1 byte	1 byte	1 byte	1 byte	1 byte	1 byte	1 byte	1 byte	1 byte	1 byte	1 byte
12 byte												1 byte

Syncword (2 byte)

The Syncword $(1110101110000000)_2$ (0xEB90) TBC allows the synchronization of the receiver. As it repeated every symbol it allows for fast and stable synchronization.

Frame-Counter (1 byte)

The Frame-Counter is a counter, which is incremented by one each frame. The F-counter allows the receiver of the modulator interface to time-synchronize different components of a **C2 system** delivered via different modulator interface fragments and to validate the completeness of the received data.

Symbol-Counter (2 byte)

The Symbol-Counter is a counter, which starts with 0x01 at the first symbol of the preamble of a frame and is incremented by one each symbol. As the preamble may allocate more than one symbol, the receiver gets also the actual length information of the frame from this counter. The Symbol-Counter allows the receiver of the modulator interface to time-synchronize the different components of a **C2 system** delivered via different modulator interface fragments at symbol level.

Num_Subcarriers (2 byte)

the **Num_Subcarriers** field gives the number of 12 multiples of the subcarriers in the current fraction of the **C2 System**. The value shall be 284, which is equivalent to $(284 \times 12) + 1 = 3409$ subcarriers transmitted in this fraction, in case a 8 MHz signal is targeted to be transmitted. The value may exceed the figure representing a 8 MHz channel in case the transmitted signal is broader than 8 MHz and the fractioning feature is not used. This means that a e.g. 64 MHz DVB-C2 signal may be transmitted as one piece (not distributed into fractions) by signaling this with a appropriate figure for the number of subcarriers. The parameter **Num_Subcarriers** would allow a transmitter bandwidth of up to 1,85 GHz.

System_Config (4 byte, transmitted in a sequence of 1 byte per symbol –multiplexing structure).

The C2-MI **System_Config** bytes delivers the relevant information about the different fractions the current **C2 system** consists of, in case the bandwidth of the **C2 System** is greater than 8 MHz.

The first byte (Num_Fractions) gives the number of fractions the current **C2 system** consists of. In case of a 8 MHz channel a pattern 0x01 shall be transmitted.

The first symbol of a **C2 frame** shall carry in the Horizontal Sync-field the **Num_Fraction** byte in the **System_Config** field.

The second to the fourth byte (Start_Frequency) is a field which gives the tuning frequency of the subcarrier the actual fraction starts with. This field is identical with the Start_Frequency-field in the DVB-C2 specification [1].

NOTE 1: The **System_Config** bytes are transmitted in a 1 byte per symbol multiplexing structure sequence. The first symbol of a frame carries the 'Num_Fraction'-byte in the related data field.

NOTE 2: The **System_Config** bytes are transmitted in a 1 byte per symbol multiplexing structure sequence because this information is static and it would not be reasonable to transmit this data in every symbol TDM structure.

NOTE 3: The Start_Frequency field allows the DVB-C2 Modulator Interface receiver to calculate the position of a certain fraction of the **C2_System**. It may be used as well to signal the RF-frequency of the related **C2_System**.

The definition of the **Symbol-Para** field is given in table 10.

Table 10: Definition of the Symbol-Para (1 byte) field

MaxMod	Symbol Type	Guard Interval	PAPR Mode	Single modulation scheme	Min bandwidth
3 bit	1 bit	1 bit	1 bit	1 bit	1 bit
1 byte					

The following section gives the definition of the elements of the Symbol-Para field:

MaxMod (3 bit)

This data field gives the maximum modulation scheme used for payload subcarriers. Details are given in table 11.

Table 11: Definition of the MaxMod field

16-QAM modulation	(000) ₂
64-QAM modulation	(001) ₂
256-QAM modulation	(010) ₂
1 024-QAM modulation	(011) ₂
4 096-QAM modulation	(100) ₂
For future use	(101) ₂
For future use	(110) ₂
For future use	(111) ₂

NOTE 4: DVB-C2 allows allocating different modulation schemes per PLP. Therefore the signaling associated to the individual subcarriers gives the deviation from the maximum modulation scheme used within this **C2 system**.

Symbol Type: (1 bit)

This field gives the type of the related symbol. Details are given in table 12.

Table 12: Definition of the Symbol Type field

Preamble symbol	(0) ₂
Data symbol	(1) ₂

Guard Interval: (1 bit)

This data field the DVB-C2 modulator Interface receiver the length of the guard interval, which has to be inserted. Details are given in table 13.

Table 13: Definition of the Guard interval field

Guard Interval 1/64	(0) ₂
Guard Interval 1/128	(1) ₂

This bit delivers the DVB-C2 modulator Interface receiver the length of the guard interval, which has to be inserted.

PAPR Mode: (1 bit)

This data field defines whether the Peak-to-Average Power Reduction (PAPR) feature of the **C2 system** is used. Details are given in table 14.

Table 14: Definition of the Guard interval field

PAPR Mode off	(0) ₂
PAPR Mode on	(1) ₂

NOTE 5: In case PAPR is activated the modulation parameters for the reserved tones are defined at client side of the DVB-C2 modulator. This is necessary because only at the client side the detection of the current sum signal level is possible and an appropriate modulation value can be calculated.

Single modulation scheme: (1 bit)

This field signals whether the **C2 system** uses only one modulation scheme within the PLPLs and **Data Slices**. Details are given in table 15.

Table 15: Definition of the 'Single modulation scheme' field

Single modulation schemes mode off	$(0)_2$
Single modulation schemes mode on	$(1)_2$

NOTE 6: The usage of a single modulation type for the payload is the most likely application. In this case this signaling allows the C2 Modulator Interface receiver to correct error in the Mod-field. The 'single modulation scheme' field may only change at frame boundaries.

Min bandwidth: (1 bit)

This field indicates whether the bandwidth of the **C2 system** is greater than 8 MHz. If the field is set to 1, the C2 Modulator Interface receiver has to assemble the complete signal by combining the different parts delivered by different C2 Modulator Interfaces associated to this **C2 system**. Details are given in table 16.

Table 16: Definition of the 'Min bandwidth' field

Bandwidth on C2 system = 8 MHz (see note 8)	$(0)_2$
Bandwidth on C2 system > 8 MHz (see note 8)	$(1)_2$

NOTE 7 : The usage of 8 MHz channels is at least likely during the DVB-C2 introduction phase.

NOTE 8: As described in the last paragraph of clause 4.1, the minimum bandwidth of 8 MHz refers to the 2,232 kHz carrier spacing (European type application). However for cable networks with 6 MHz channel raster 6 MHz minimum bandwidth is applicable accordingly (for further details see clause 10.1 in [1]).

C2_System_ID (2 byte)

This 16-bit field uniquely identifies a **C2 system** within the DVB-C2 network. The **C2_System_ID** is the identifier of the output signal of a DVB-C2 Modulator, as defined in the DVB-C2 specification [1].

NOTE 9: The **C2_System_ID** allows the DVB-C2 MI receiver to identify all relevant components for the targeted **C2 system** (in case of transmitter bandwidth > 8 MHz).

MI-Version Number (1 byte)

This field gives the version number of the C2 Modulator Interface in use. Details are given in table 17.

Table 17: Definition of the 'MI-Version-Number' field

Bit	MSB						LSB
parameter	Future use	Future use	Future use	Future use	Future use	DVB-C2 MI Version Number	

The **Future use** bits are for future usage and shall be set to $(0)_2$.

Table 18 gives the syntax of the **DVB-C2 MI version number** field.

Table 18: Syntax of the DVB-C2 MI version number field (3 bit)

Code	Parameter	Comment
000	Version 1	As specified in the present document
001-111	For future use	

CRC (1 byte)

CRC is the cyclic redundancy check word as defined in annex A of the present document.

7 DVB-C2 MI transmission, payload and overhead capacity per 8 MHz channel

This clause discusses the relation of the payload capacity to the overall transmission capacity required by the C2 Modulator Interface. Table 19 gives figures for the overhead for the application as discussed in figure 5 of clause 5.2.1 and table 20 gives figures for the overhead for the application as discussed in figure 4 of clause 5.2.

Table 19: Payload capacity per 8 MHz Channel (Multiple PLP configuration)

Modulation	Transmission bit rate of the C2 Modulator-Interface	max C2 system Payload/8 MHz	Overhead
16-QAM	$5 \times 3 \ 457 \times (1/448 \text{ us}) = 38,6 \text{ Mbit/s}$	26,6 Mbit/s	45,1 %
64-QAM	$7 \times 3 \ 457 \times (1/448 \text{ us}) = 54,0 \text{ Mbit/s}$	39,7 Mbit/s	36,0 %
256-QAM	$9 \times 3 \ 457 \times (1/448 \text{ us}) = 69,4 \text{ Mbit/s}$	52,9 Mbit/s	31,2 %
1 024-QAM	$13 \times 3 \ 457 \times (1/448 \text{ us}) = 84,6 \text{ Mbit/s}$	66,1 Mbit/s	28,0 %
4 096-QAM	$15 \times 3 \ 457 \times (1/448 \text{ us}) = 100,29 \text{ Mbit/s}$	79,4 Mbit/s	26,3 %

Table 20: Payload capacity per 8 MHz Channel (Single PLP configuration)

Modulation	Transmission bit rate of the C2 Modulator-Interface	max C2 system Payload/8 MHz	Overhead
16-QAM	$\frac{104+3409 \cdot (5 \cdot 5+444 \cdot 4)}{449} \div (448E - 6) \text{ bit/s} = 30,5 \text{ Mbit/s}$	26,6 Mbit/s	14,7 %
64-QAM	$\frac{104+3409 \cdot (5 \cdot 7+444 \cdot 6)}{449} \div (448E - 6) \text{ bit/s} = 45,7 \text{ Mbit/s}$	39,7 Mbit/s	15,2 %
256-QAM	$\frac{104+3409 \cdot (5 \cdot 9+444 \cdot 8)}{449} \div (448E - 6) \text{ bit/s} = 61,0 \text{ Mbit/s}$	52,9 Mbit/s	15,2 %
1 024-QAM	$\frac{104+3409 \cdot (5 \cdot 11+444 \cdot 10)}{449} \div (448E - 6) \text{ bit/s} = 76,2 \text{ Mbit/s}$	66,1 Mbit/s	15,2 %
4 096-QAM	$\frac{104+3409 \cdot (5 \cdot 13+444 \cdot 12)}{449} \div (448E - 6) \text{ bit/s} = 91,4 \text{ Mbit/s}$	79,4 Mbit/s	15,1 %

8 Transport of C2-MI packets

The structure of the C2-MI protocol stack described in clause 4.2 allows three mechanisms for distribution; one for traditional ASI interfaces, the two mechanisms for IP based networks.

The first two mechanisms rely on first inserting the C2-MI packets into DVB/MPEG-2 TS packets which can then be interfaced to a distribution network via such interfaces as described in EN 50083-9 [i.1]. The resulting TS can then be further encapsulated into an IP stream using the DVB IPTV standard, TS 102 034 [3].

The third transport mechanism, which is optional, maps C2-MI packets directly into in IP packets.

8.1 Encapsulation of C2-MI packets in MPEG-2 TS

The insertion of C2-MI packets into MPEG-2 TS packets shall be in accordance with EN 301 192 [2], clause 4, "Data Piping". This mechanism allows for the insertion of data directly into the payload of MPEG-2 TS packets with the minimum of additional overhead.

8.1.1 Description

The C2-MI packets are inserted, one after another, into the payload of MPEG-2 TS packets. Each new C2-MI packet shall start immediately following the previous one. A TS packet may contain more than one C2-MI packet. C2-MI packets that are too big to fit into the payload of a single TS packet shall be split across multiple TS packets as required.

Since the length of each C2-MI packet may change within a C2-Frame and/or over time, the start of a TS packet's payload does not necessarily coincide with the start of a C2-MI packet. To enable synchronization within a device receiving C2-MI, the "payload_unit_start_indicator" bit in the TS header shall be used to indicate that a new C2-MI packet starts somewhere within the current TS packet. When this is the case an 8-bit pointer shall be positioned as the first payload byte of the TS packet, indicating the offset from the start of the TS payload to the first byte of the first C2-MI packet. This 8-bit pointer field (uimsbf) shall indicate the number of bytes immediately following the pointer field until the first byte of the first C2-MI packet that is present in the payload of the **Transport Stream** packet (i.e. a value of 0x00 in the pointer field indicates that the C2-MI packet starts immediately after the pointer field). This is illustrated in figure 6.

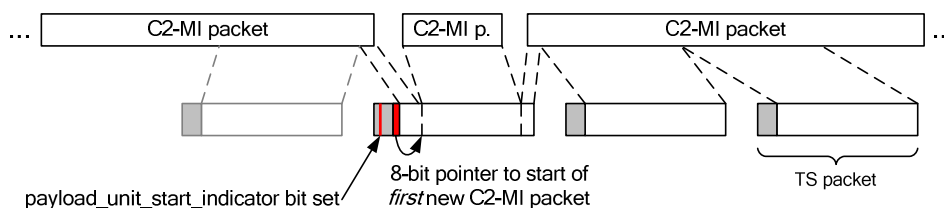

Figure 6: Encapsulation of C2-MI Packets in MPEG-2 TS

Using this mechanism the C2-MI packet can begin anywhere in the TS packet. There is no requirement to have C2-MI packets beginning at the start of a TS packet and no need for unnecessary stuffing.

NOTE 1: Since the TS packets containing C2-MI packets are carrying a data type not defined by MPEG, EN 301 192 [2] allows the use of the "payload_unit_start_indicator" bit in this "service private way".

When a C2-MI packet ends at the last-but-one byte of a TS packet and starts in a previous TS packet, the one remaining byte does not allow space for both the insertion of the 8-bit pointer field and the first byte of the next C2-MI packet. In this case the size of the payload of the TS packet shall be reduced by one byte through the use of adaptation field stuffing [5] such that the current C2-MI packet finishes at the end of the TS packet payload. The next C2-MI packet shall start in the next TS packet having the same PID.

NOTE 2: Arbitrary amounts of padding may also be added, if required, at this layer through the use of arbitrary numbers of stuffing bytes in the adaptation field of the **Transport Stream** packet [5].

EXAMPLE: A C2-MI packet is being transmitted. Most of the C2-MI packet has been transmitted and only 50 bytes remain to be sent. The next C2-MI packet is not yet available and there are therefore not enough bytes to fill up a TS packet. To allow this TS packet to be transmitted immediately, an adaptation field of total length 134 bytes (adaptation_field_length = 133) containing stuffing bytes can be inserted before the payload.

For carriage over managed distribution networks it may be necessary to add a minimum of PSI in order to prevent erroneous alarms from being set. This would normally comprise a PAT, and PMT for a single "Program" as defined in ISO/IEC 13818-1 [5]. The Stream Type to be used in the PMT is not defined in EN 301 192 [2]. For the purposes of interoperability, it should be set to 0x06.

Similarly, some networks may require the carriage of mandatory DVB SI tables, and reference should be made to EN 300 468 [6] for the appropriate values to be used in such tables.

8.2 Encapsulation of MPEG-2 TS in IP packets

A DVB-C2 modulator may support the transport of MPEG-2 TS over IP. In case the DVB-C2 modulator supports IP-based delivery, the transport of MPEG-2 TS over IP shall follow the specification in this clause. The transport of MPEG-2 TS over IP relies on the methods specified in TS 102 034 [3]. This clause specifies a protocol for FEC protected multicast delivery of MPEG-2 **Transport Streams** over RTP and is based on IP version 4 according to [3]. IP version 6 is not supported.

Unicast delivery of MPEG-2 **Transport Streams** over IP is outside the scope of the specification. However, the unicast transport may rely on the same protocol as specified in clause 8.2.2.

8.2.1 Setup Information

For delivering FEC-protected, multicast MPEG-2 **Transport Streams** over RTP using the protocols in TS 102 034 [3], the following setup information should be provided according to [3], clause 5.2.6.2, table 4:

- IPMulticastAddress:
 - IPMulticastAddress@Source: Optionally the IP unicast address of the source of the TS may be provided.
 - IPMulticastAddress@Address: Provides the multicast address at which the service may be accessed.
 - IPMulticastAddress@Port: Provides the port at which the service may be accessed.
 - FECBaseLayer: Contains the multicast address and port of the AL-FEC stream. This element shall be present if the FECBaseLayer element is present:
 - FECBaseLayer@Address: IP Multicast Address for FEC Base Layer. If the IP multicast address is omitted, then the FEC flow is assumed to be on the same multicast address as the original data.
 - FECBaseLayer@Source: IP Multicast Source Address for FEC Base Layer. If the IP multicast source address is omitted, then the FEC flow is assumed to be on the same multicast source address as the original data.
 - FECBaseLayer@Port: UDP port for FEC Base Layer.
 - FECEnhancementLayer: Contains the multicast address and port of the AL-FEC enhancement stream(s). This element shall only be present if the FECBaseLayer element is present. This element may be repeated for multiple layers.
 - FECEnhancementLayer@Address: IP Multicast Address for FEC Enhancement Layer. If the IP multicast address is omitted, then the FEC flow is assumed to be on the same multicast address as the original data.
 - FECEnhancementLayer@Source: IP Multicast Source Address for FEC Enhancement Layer. If the IP multicast source address is omitted, then the FEC flow is assumed to be on the same multicast source address as the original data.
 - FECEnhancementLayer@Port: UDP port for FEC Enhancement Layer.
 - IPMulticastAddress@FECMaxBlockSizePackets: This indicates the maximum number of stream source packets that will occur between the first packet of a source block (which is included) and the last packet for that source block (source or repair).
 - IPMulticastAddress@FECMaxBlockSizeTime: The maximum transmission duration of any FEC Block (source and repair packets).
 - IPMulticastAddress@FECObjectTransmissionInformation: The FEC Object Transmission Information for the Raptor code. If a FECEnhancementLayer element is included then this element shall be included.

For details of the semantics of these parameters refer to [3].

8.2.2 Transport protocols

Where the MPEG-2 TS is transported over IP, the MPEG-2 TS shall be encapsulated in RTP (Real-time Transport Protocol) according to RFC 3550 [4] as specified in TS 102 034 [3], clause 7.1.1.

RTCP sender reports and receiver reports shall not be used.

FEC protection of the MPEG-2 **Transport Stream** may be provided according to TS 102 034 [3], clauses E.3 and E.4. When a DVB AL-FEC enhancement layer is provided, the FEC Scheme defined in TS 102 034 [3], clause E.4.3.2 shall be used.

DVB-C2 modulators that support the transport of MPEG-2 TS over IP shall support the minimum decoder requirements according to [3], clause E.5.1.1, i.e. FEC decoders shall support processing of the DVB AL-FEC base layer packets.

DVB-C2 modulators that support the transport of MPEG-2 TS over IP may support the enhanced decoder requirements according to [3], clause E.5.1.2, i.e. FEC decoders may support processing of the DVB AL-FEC base layer and DVB AL-FEC enhancement layer packets.

8.2.3 Session initiation and control

Session initiation is outside the scope of the specification. The session initiation and control for the multicast distribution according to TS 102 034 [3], clause 7.3.1 may be used.

8.2.4 Network requirements

The network requirements for the multicast distribution shall be in accordance with TS 102 034 [3], clause 7.2.

In case application layer FEC is applied, the network requirements may be relaxed. For configuration examples of application layer FEC for different network characteristics, refer to DVB bluebook A115 [i.2].

Annex A (normative): Calculation of the CRC word

The implementation of Cyclic Redundancy Check codes (CRC-codes) allows the detection of transmission errors at the receiver side. For this purpose CRC words shall be included in the transmitted data. These CRC words shall be defined by the result of the procedure described in this annex.

A CRC code is defined by a polynomial of degree n :

$$G_n(x) = x^n + g_{n-1}x^{n-1} + \dots + g_2x^2 + g_1x + 1$$

with $n \geq 1$:

and: $g_i \in \{0,1\}$, $i = 1, \dots, n-1$

The CRC calculation may be performed by means of a shift register containing n register stages, equivalent to the degree of the polynomial (see figure A.1). The stages are denoted by $b_0 \dots b_{n-1}$, where b_0 corresponds to 1, b_1 to x , b_2 to x^2, \dots, b_{n-1} to x^{n-1} . The shift register is tapped by inserting XORs at the input of those stages, where the corresponding coefficients g_i of the polynomial are '1'.

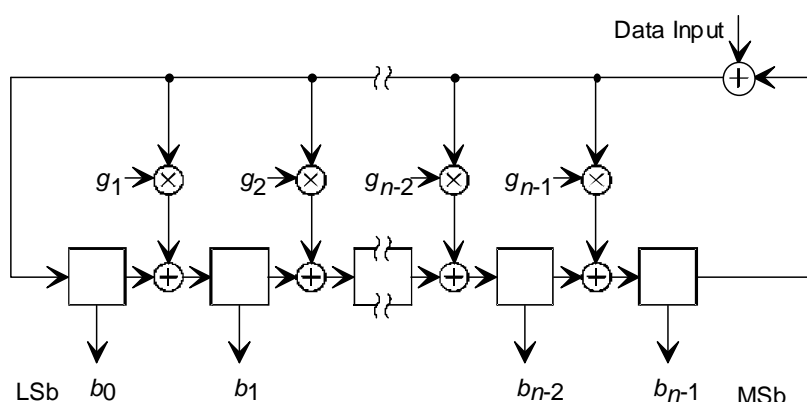

Figure A.1: General CRC block diagram

At the beginning of the CRC-8 calculation (used for horizontal sync fields only), all register stage contents are initialized to zeros.

At the beginning of the CRC-32 calculation, all register stage contents are initialized to ones.

After applying the first bit of the data block (MSB first) to the input, the shift clock causes the register to shift its content by one stage towards the MSB stage (b_{n-1}), while loading the tapped stages with the result of the appropriate XOR operations. The procedure is then repeated for each data bit. Following the shift after applying the Last Bit (LSB) of the data block to the input, the shift register contains the CRC word which is then read out. Data and CRC word are transmitted with MSB first.

The CRC codes used in the DVB-C2 MI system are based on the following polynomials:

$$G_{32}(x) = x^{32} + x^{26} + x^{23} + x^{22} + x^{16} + x^{12} + x^{11} + x^{10} + x^8 + x^7 + x^5 + x^4 + x^2 + x + 1$$

$$G_8(x) = x^8 + x^7 + x^6 + x^4 + x^2 + 1$$

The assignment of the polynomials to the respective applications is given in each clause.

NOTE: The CRC-32 coder defined in this annex is identical to the implicit encoder defined in EN 302 769 [1].

Annex B (informative): Examples for the usage of the C2 Modulator Interface

This informative annex gives examples, how the high level of flexibility of the DVB-C2 system is supported by the C2 Modulator Interface

Example B.1 is a simple configuration, where the **C2 system** delivers a single TS or GSE stream in a single PLP and in one **Data Slice** via a 8 MHz cable channel.

Example B.2 is a configuration where several TS or GSE-streams are transmitted in several PLPs.

Whereas the first two configuration resulted in a single stream at the output of the C2 Modulator Interface, the example B.3 gives a configuration with two **PLPs**, two **Data Slices** and a **Broadband notch** between the two **Data Slices**. For reasons of efficiency, this configuration uses the fragmentation mechanism of the C2 Modulator Interface in order not to transmit the (non existing) payload of the subcarriers in the notch range.

B.1 Example of a C2 Modulator Interface configuration for a **C2 System** in a single **PLP/single Data Slice** (Type 1) configuration with 8 MHz RF bandwidth

In case a cable operator wants to start migration from today 256-QAM@DVB-C to DVB-C2 without modifications in the infrastructure 1 024-QAM will be the right choice. In the starting phase compatibility with the established channel raster of 8 MHz will most likely be also essential. Therefore this example of the application the C2 Modulator Interface addresses the following parameter configuration:

DVB-C2, 1 024-QAM, 9/10 FEC rate, 8 MHz, Guard Interval 1/128, no PAPR, single PLP and single **Data Slice** configuration, transmission in the cable channel with 346 MHz center frequency, **C2_System_ID** 0x0001.

Table B.1: Coding of the Symbol-Para field

MaxMod	Symbol Type	Guard Interval	PAPR Mode	Single modulation scheme	Min bandwidth
$(011)_2$	$(x)_2$	$(1)_2$	$(0)_2$	$(1)_2$	$(1)_2$
1 byte					

Table B.2: Coding of the Horizontal Sync field of the first symbol of the DVB-C2 frame

Horizontal Sync-field											CRC	
Syncword		Frame-counter	Symbol-Counter		NumSubcarrier		System-config	Symbol-Para	C2_sytem_ID		MI-Version Number	CRC
0x90	0xFB	1 byte	0x00	0x01	0x1C	0x01	0x01	0xEE	0x00	0x01	1 byte	1 byte
12 byte												1 byte

The **Horizontal Sync** fields of the following symbols in the TDM structure will differ from the field of the first symbol as discussed hereafter:

- The **Symbol Counter** field will be incremented for every symbol of the related frame.
- The **System config** field will deliver with the following three symbols the **Start Frequency** as defined in clause 8.3 of [3]. For this examples the Start Frequency is calculated as following:
 - The transmitter **Centre Frequency** 346 MHz is converted to 345 964 285,7 Hz (which can be divided by 24 (pilot spacing in case of 1/128 GI) and is a multiple of the carrier spacing.
- The **Centre Frequency** (345 964 285,7 Hz) divided by the carrier spacing (1/448 us) is 154 992.

- The **C2 system** of this examples has 8 MHz bandwidth, which is equivalent to 3 409 subcarriers. The distance from the center frequency to the frequency of the low-end edge pilot is 1 704 times the subcarrier spacing.
- The parameter Start Frequency is now: $154\,992 - 1\,704 = 153\,288$ (0 x 0256C8).
- The bytes 0x02, 0x56 and 0xC8 are transmitted in the **System config** field in the 2nd to the 4th symbol.
- This sequence is repeated every 4 symbols until the end of the C2 frame.

In this mode (single PLP) for all payload carriers the modulation scheme given with the MaxMod field applies. Therefore there is no necessity to transmit the modulation scheme per subcarrier in the mode field. However the constellation of the pilots needs to be delivered to the MI receiver.

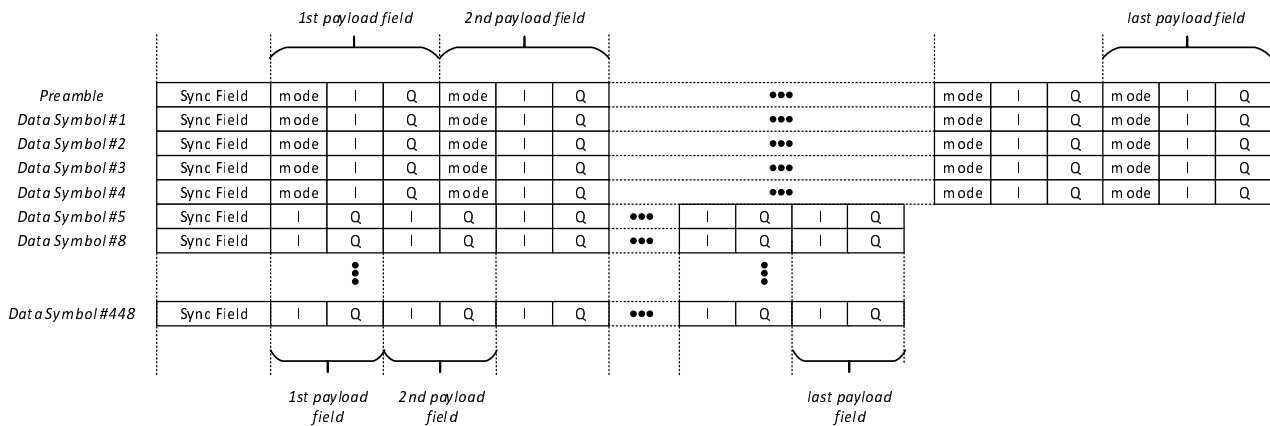

Figure B.1

Figure B.1 shows the framing structures of this configuration.

The following length on the different fields applies for this example: Sync Field: 12 byte, mode 1 bit, I-/Q-Field: 5 bit.

The overall transmission capacity of the signal distribution system can be calculated as given in table 20 of clause 7.

$$\frac{104 + 3409 \cdot (5 \cdot 11 + 444 \cdot 10)}{449} \div (448E - 6) \text{ bit/s} = 76,2 \text{ Mbit/s}$$

B.2 Example of a C2 Modulator Interface configuration for a **C2 System** with 8 MHz RF bandwidth and a multiple **PLPs/Data Slices** configuration

DVB-C2, 1 024-QAM, 9/10 FEC rate, 8 MHz, Guard Interval 1/128, no PAPR, multiple PLPs and multiple **Data Slices** configuration, transmission in the cable channel with 346 MHz center frequency, **C2_System_ID** 0x0002.

Table B.3: Coding of the Symbol-Para field

MaxMod	Symbol Type	Guard Interval	PAPR Mode	Single modulation scheme	Min bandwidth
$(011)_2$	$(x)_2$	$(1)_2$	$(0)_2$	$(1)_2$	$(1)_2$
1 byte					

Table B.4: Coding of the Horizontal Sync field

Horizontal Sync-field											CRC	
Syncword		Frame-counter	Symbol-Counter		NumSubcarrier		System-config	Symbol-Para	C2_system_ID		MI-Version Number	CRC
0x90	0xFB	1 byte	0x00	0x01	0x1C	0x01	0x01	0xEE	0x00	0x02	1 byte	1 byte
12 byte											1 byte	

The **Horizontal Sync** fields of the following symbols in the TDM structure will differ from the field of the first symbol as discussed hereafter:

- The **Symbol Counter** field will be incremented for every symbol of the related frame.
- The **System config** field will deliver with the following three symbols the **Start Frequency** as defined in clause 8.3 of [4]. For this examples the Start Frequency is calculated as following:
 - The transmitter **Centre Frequency** 346 MHz is converted to 345 964 285,7 Hz (which can be divided by 24 (pilot spacing in case of 1/128 GI) and is a multiple of the carrier spacing.
- The **Centre Frequency** (345 964 285,7 Hz) divided by the carrier spacing (1/448 us) is 154 992.
- The **C2 system** of this examples has 8 MHz bandwidth, which is equivalent to 3 409 subcarriers. The distance from the center frequency to the frequency of the low-end edge pilot is 1 704 times the subcarrier spacing.
- The parameter Start Frequency is now: $154\ 992 - 1\ 704 = 153\ 288$ (0x0256C8).
- The bytes 0x02, 0x56 and 0xC8 are transmitted in the **System config** field in the 2nd to the 4th symbol.
- This sequence is repeated every 4 symbols until the end of the C2 frame.

For this configuration we need the full flexibility of signalling the modulation scheme per subcarrier. The singling scheme requires only the 1 bit Mod-field for signalling. This is possible with the principle that in case the modulation scheme is lower than MaxMod automatically several (depending on the modulation scheme) data bits in the I- and Q-field are no longer needed for delivery of the modulation scheme and are therefore used for signalling of the modulation scheme. Details are defined in clause 5.

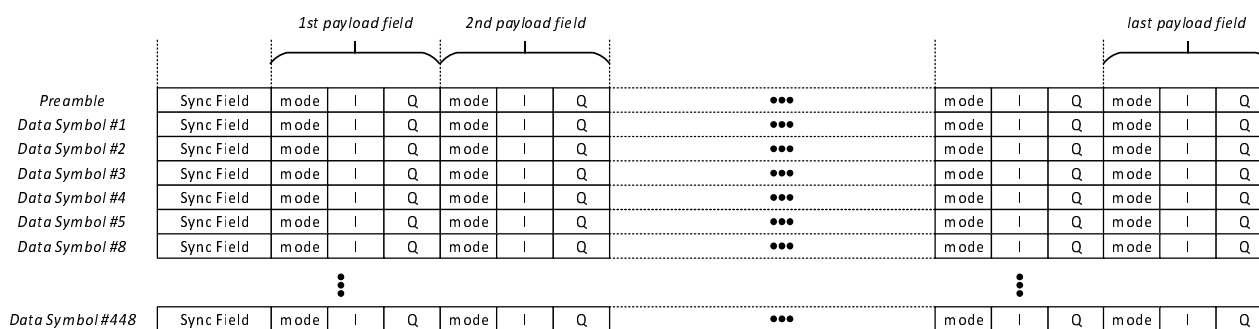

Figure B.2

B.3 Example of a C2 Modulator Interface configuration for a C2 System with 22 MHz RF band and a Broadband notch

This example addresses a **C2 System** with 33 MHz bandwidth, a maximum modulation scheme of 1 024-QAM, multiple PLPs/**Data Slices**, 1/128 Guard Interval and no PAPR. It has the following structure as given in table B.5.

Table B.5: Configuration of the payload and Broadband notch subcarriers

Number of subcarriers of the total C2 system		
9 681		
Number of subcarriers of the low end Payload section	Number of subcarriers of the Broadband notch section	Number of subcarriers of the high end Payload section
3 408	2 960	3 313

At the low end of the spectrum there is a payload band occupying a full 8 MHz channel, followed by a **Broadband notch** with 6,6 MHz bandwidth and a payload band of 7,6 MHz.

The C2 Modulator Interface transmitter requires two streams to transport this DVB-C2 signal configuration to the C2 Modulator Interface receiver. There is of course no need to deliver payload data for the **Broadband notch** section.

The 'Num_Fraction'-field is set to 0x02 and the 'Subcarrier_Pos'-field is set to 0x000001 for the first fraction and to 0x0018E1 ((3 408 + 2 960 + 1) = 6 369 in decimal notation) for the second fraction.

This example configuration results in two fragments to be transmitted. The first fragment is transmitted with the following parameters:

Table B.6: Coding of the Symbol-Para field

MaxMod	Symbol Type	Guard Interval	PAPR Mode	Single modulation scheme	Min bandwidth
$(011)_2$	$(X)_2$	$(1)_2$	$(0)_2$	$(0)_2$	$(1)_2$
1 byte					

Table B.7: Coding of the Horizontal Sync field

Horizontal Sync-field												CRC
Syncword		Frame-counter	Symbol-Counter		NumSubcarrier		System-config	Symbol-Para	C2_sytem_ID		MI-Version Number	CRC
0x90	0xFB	1 byte	0x00	0x01	0x1C	0x01	0x02	0xEE	0x01	0x00	1 byte	1 byte
12 byte												1 byte

The **Horizontal Sync** fields of the following symbols in the TDM structure will differ from the field of the first symbol as discussed hereafter:

- The **Symbol Counter** field will be incremented for every symbol of the related frame.
- The **System config** field will deliver with the following three symbols the **Start Frequency** as defined in clause 8.3 of [5]. For this examples the Start Frequency is calculated as following:
 - The transmitter **Centre Frequency** 346 MHz is converted to 345 964 285,7 Hz (which can be divided by 24 (pilot spacing in case of 1/128 GI) and is a multiple of the carrier spacing).
- The **Centre Frequency** (345 964 285,7 Hz) divided by the carrier spacing (1/448 us) is 154 992.
- The **C2 system** of this examples has 8 MHz bandwidth, which is equivalent to 3 409 subcarriers. The distance from the center frequency to the frequency of the low-end edge pilot is 1 704 times the subcarrier spacing.
- The parameter Start Frequency is now: 154 992 – 1 704 = 153 588 (0x0256C8).
- The bytes 0x02, 0x56 and 0xC8 are transmitted in the **System config** field in the 2nd to the 4th symbol.
- This sequence is repeated every 4 symbols until the end of the C2 frame.

The second fragment is transmitted with the parameters as given in table B.8.

Table B.8: Coding of the Symbol-Para field

MaxMod	Symbol Type	Guard Interval	PAPR Mode	Single modulation scheme	Min bandwidth
$(011)_2$	$(X)_2$	$(1)_2$	$(0)_2$	$(0)_2$	$(1)_2$
1 byte					

Table B.9: Coding of the Horizontal Sync field

Horizontal Sync-field												CRC
Syncword		Frame-counter	Symbol-Counter		NumSubcarrier		System-config	Symbol-Para	C2_sytem_ID		MI-Version Number	CRC
0x90	0xFB	1 byte	0x00	0x01	0x1C	0x01	0x02	0xEE	0x01	0x00	1 byte	1 byte
12 byte												1 byte

The **Horizontal Sync** fields of the following symbols in the TDM structure will differ from the field of the first symbol as discussed hereafter:

- The **Symbol Counter** field will be incremented for every symbol of the related frame.
- The **System config** field will deliver with the following three symbols the **Start Frequency** as defined in clause 8.3 of [6]. For this examples the Start Frequency is calculated as following:
 - The transmitter **Centre Frequency** 346 MHz is converted to 345 964 285,7 Hz (which can be divided by 24 (pilot spacing in case of 1/128 GI) and is a multiple of the carrier spacing).
- The **Centre Frequency** (345 964 285,7 Hz) divided by the carrier spacing (1/448 us) is 154 992.
- The **C2 system** of this examples has 8 MHz bandwidth, which is equivalent to 3 409 subcarriers. The distance from the center frequency to the frequency of the low-end edge pilot is 1 704 times the subcarrier spacing.
- The parameter Start Frequency is now: $154\,992 - 1\,704 = 153\,288$ (0x0256C8).
- The bytes 0x02, 0x56 and 0xC8 are transmitted in the **System config** field in the 2nd to the 4th symbol.
- This sequence is repeated every 4 symbols until the end of the C2 frame.

Annex C (informative): Labeling of C2 Modulator Interface (C2-MI) devices

The flexibility of the **C2 system** as given in [1] is fully supported by the specification of the C2 Modulator Interface. However, implementations of DVB-C2 modulators may only support the mandatory and not all the optional features. In order to allow an easy check, whether a DVB-C2 modulator works with a certain C2 Modulator Interface device, the labeling for C2-MI devices as given in table C.1 should be used.

Table C.1

Profile	Transport	Format	Fractioning	Bandwidth	Comment
I	UDP	TSP	No	8 MHz	Only Transport Stream (TS) support with IP transport protocol and optionally ASI
II	UDP/RTP	TSP/C2MIP	No	8 MHz	Profile I + direct mapping of C2MI packet into IP
IlaN	UDP/RTP	TSP/C2MIP	No	N: modulator bandwidth N > 8 MHz	Profile II + support of modulator bandwidth > 8 MHz output bandwidth of the DVB-C2 modulator
IlbN	UDP/RTP	TSP/C2MIP	Yes	N: modulator bandwidth N > 8 MHz	Profile Ila + support of fractioning

Annex D (informative): Bibliography

ETSI TS 102 991: "Digital Video Broadcasting (DVB); Implementation guidelines for a second generation digital cable transmission system (DVB-C2)".

ETSI TR 101 290: "Digital Video Broadcasting (DVB); Measurement guidelines for DVB systems".

ETSI TS 102 606: "Digital Video Broadcasting (DVB); Generic Stream Encapsulation (GSE) Protocol".

ETSI TS 102 771: "Digital Video Broadcasting (DVB); Generic Stream Encapsulation (GSE) implementation guidelines".

History

Document history		
V1.1.1	September 2014	Publication