



**Integrated broadband cable
telecommunication networks (CABLE);
Testing; Conformance test specifications
for MAP-E technology;
Part 3: Abstract Test Suite (ATS) and
Protocol Implementation eXtra Information for Testing (PIXIT)**

Reference

DTS/CABLE-00012-3

Keywords

ATS, CPE, IP, IPv6, transition

ETSI

650 Route des Lucioles
F-06921 Sophia Antipolis Cedex - FRANCE

Tel.: +33 4 92 94 42 00 Fax: +33 4 93 65 47 16

Siret N° 348 623 562 00017 - NAF 742 C
Association à but non lucratif enregistrée à la
Sous-Préfecture de Grasse (06) N° 7803/88

Important notice

The present document can be downloaded from:

<http://www.etsi.org>

The present document may be made available in electronic versions and/or in print. The content of any electronic and/or print versions of the present document shall not be modified without the prior written authorization of ETSI. In case of any existing or perceived difference in contents between such versions and/or in print, the only prevailing document is the print of the Portable Document Format (PDF) version kept on a specific network drive within ETSI Secretariat.

Users of the present document should be aware that the document may be subject to revision or change of status. Information on the current status of this and other ETSI documents is available at

<http://portal.etsi.org/tb/status/status.asp>

If you find errors in the present document, please send your comment to one of the following services:

http://portal.etsi.org/chaicor/ETSI_support.asp

Copyright Notification

No part may be reproduced or utilized in any form or by any means, electronic or mechanical, including photocopying and microfilm except as authorized by written permission of ETSI.

The content of the PDF version shall not be modified without the written authorization of ETSI.

The copyright and the foregoing restriction extend to reproduction in all media.

© European Telecommunications Standards Institute 2014.

All rights reserved.

DECT™, **PLUGTESTS™**, **UMTS™** and the ETSI logo are Trade Marks of ETSI registered for the benefit of its Members. **3GPP™** and **LTE™** are Trade Marks of ETSI registered for the benefit of its Members and of the 3GPP Organizational Partners.

GSM® and the GSM logo are Trade Marks registered and owned by the GSM Association.

Contents

Intellectual Property Rights	5
Foreword.....	5
Modal verbs terminology.....	5
1 Scope	6
2 References	6
2.1 Normative references	6
2.2 Informative references.....	7
3 Definitions and abbreviations.....	7
3.1 Definitions.....	7
3.2 Abbreviations	7
4 Abstract test method.....	8
4.1 Abstract protocol tester	8
4.2 Test configurations	9
4.2.1 CF01: BR as IUT	9
4.2.2 CF02: CPE as IUT	10
4.3 TTCN-3 Test architecture.....	10
4.4 Ports and ASPs (Abstract Services Primitives)	13
4.4.1 TTCN-3 ports.....	13
4.4.2 Abstract Service Primitives	13
5 Implemented Test Purposes.....	14
6 ATS conventions	14
6.1 Naming conventions.....	14
6.1.1 General guidelines	14
6.1.2 MAP-E specific TTCN-3 naming conventions.....	15
6.1.3 Usage of Log statements.....	16
6.1.4 Test Case (TC) identifier	16
6.2 On line documentation	17
Annex A (normative): Partial PIXIT proforma for MAP-ETSI.....	18
A.1 Identification summary.....	18
A.2 ATS summary	18
A.3 Test laboratory.....	18
A.4 Client identification.....	19
A.5 SUT	19
A.6 Protocol layer information.....	19
A.6.1 Protocol identification	19
A.6.2 IUT information	20
Annex B (normative): PCTR Proforma for MAP-E.....	21
B.1 Identification summary.....	21
B.1.1 Protocol conformance test report.....	21
B.1.2 IUT identification	21
B.1.3 Testing environment.....	21
B.1.4 Limits and reservation	22
B.1.5 Comments.....	22
B.2 IUT Conformance status	22
B.3 Static conformance summary	22

B.4	Dynamic conformance summary.....	23
B.5	Static conformance review report.....	23
B.6	Test campaign report.....	24
B.7	Observations.....	25
Annex C (normative):	TTCN-3 library modules.....	26
C.1	Electronic annex, zip file with TTCN-3 code	26
Annex D (informative):	Bibliography.....	27
History	28

Intellectual Property Rights

IPRs essential or potentially essential to the present document may have been declared to ETSI. The information pertaining to these essential IPRs, if any, is publicly available for **ETSI members and non-members**, and can be found in ETSI SR 000 314: *"Intellectual Property Rights (IPRs); Essential, or potentially Essential, IPRs notified to ETSI in respect of ETSI standards"*, which is available from the ETSI Secretariat. Latest updates are available on the ETSI Web server (<http://ipr.etsi.org>).

Pursuant to the ETSI IPR Policy, no investigation, including IPR searches, has been carried out by ETSI. No guarantee can be given as to the existence of other IPRs not referenced in ETSI SR 000 314 (or the updates on the ETSI Web server) which are, or may be, or may become, essential to the present document.

Foreword

This Technical Specification (TS) has been produced by ETSI Technical Committee Integrated broadband cable telecommunication networks (CABLE).

The present document is part 3 of a multi-part deliverable covering the conformance test specification for MAP-E technology, as identified below:

Part 1: "Protocol Implementation Conformance Statement (PICS) proforma";

Part 2: "Test Suite Structure and Test Purposes (TSS&TP)";

Part 3: "Abstract Test Suite (ATS) and Protocol Implementation eXtra Information for Testing (PIXIT)".

The development of the present document follows the guidance provided in the ETSI EG 202 798 [i.1]. Therefore the present document is also based on the guidance provided in ETSI EG 202 798 [i.1].

Modal verbs terminology

In the present document "**shall**", "**shall not**", "**should**", "**should not**", "**may**", "**may not**", "**need**", "**need not**", "**will**", "**will not**", "**can**" and "**cannot**" are to be interpreted as described in clause 3.2 of the [ETSI Drafting Rules](#) (Verbal forms for the expression of provisions).

"**must**" and "**must not**" are **NOT** allowed in ETSI deliverables except when used in direct citation.

1 Scope

The present document contains the Abstract Test Suite (ATS) for MAP-E technology as defined in [1] and addressing specific cable industry requirements as defined in ETSI TS 101 569-1 [11] in compliance with the relevant requirements and in accordance with the relevant guidance given in ISO/IEC 9646-7 [5].

The objective of the present document is to provide a basis for conformance tests for MAP-E technology equipment giving a high probability of inter-operability between different manufacturer's equipment.

These ISO standards for the methodology of conformance testing (ISO/IEC 9646-1 [2] and ISO/IEC 9646-2 [3]) as well as the ETSI rules for conformance testing (ETSI ETS 300 406 [6]) are used as a basis for the test methodology.

2 References

References are either specific (identified by date of publication and/or edition number or version number) or non-specific. For specific references, only the cited version applies. For non-specific references, the latest version of the reference document (including any amendments) applies.

Referenced documents which are not found to be publicly available in the expected location might be found at <http://docbox.etsi.org/Reference>.

NOTE: While any hyperlinks included in this clause were valid at the time of publication, ETSI cannot guarantee their long term validity.

2.1 Normative references

The following referenced documents are necessary for the application of the present document.

- [1] Draft-ietf-softwire-map-12: "Mapping of Address and Port with Encapsulation (MAP)".
- [2] ISO/IEC 9646-1 (1994): "Information technology -- Open Systems Interconnection -- Conformance testing methodology and framework -- Part 1: General concepts".
- [3] ISO/IEC 9646-2 (1994): "Information technology -- Open Systems Interconnection -- Conformance testing methodology and framework -- Part 2: Abstract Test Suite specification".
- [4] ISO/IEC 9646-6 (1994): "Information technology -- Open Systems Interconnection -- Conformance testing methodology and framework -- Part 6: Protocol profile test specification".
- [5] ISO/IEC 9646-7 (1995): "Information technology -- Open Systems Interconnection -- Conformance testing methodology and framework -- Part 7: Implementation Conformance Statements".
- [6] ETSI ETS 300 406 (1995): "Methods for testing and Specification (MTS); Protocol and profile conformance testing specifications; Standardization methodology".
- [7] ETSI ES 201 873-1: "Methods for Testing and Specification (MTS); The Testing and Test Control Notation version 3; Part 1: TTCN-3 Core Language".
- [8] Void.
- [9] Void.
- [10] ETSI TS 103 239-2: "Integrated broadband cable telecommunication networks (CABLE); Testing; Conformance test specifications for MAP-E technology; Part 2: Test Suite Structure and Test Purposes (TSS&TP)".
- [11] ETSI TS 101 569-1: "Integrated Broadband Cable Telecommunication Networks (CABLE); Cable Network Transition to IPv6 Part 1: IPv6 Transition Requirements".

2.2 Informative references

The following referenced documents are not necessary for the application of the present document but they assist the user with regard to a particular subject area.

- [i.1] ETSI EG 202 798: "Intelligent Transport Systems (ITS); Testing; Framework for conformance and interoperability testing".

3 Definitions and abbreviations

3.1 Definitions

For the purposes of the present document, the terms and definitions given in ETSI TS 101 569-1 [11], ISO/IEC 9646-1 [2] and ISO/IEC 9646-7 [5] apply.

3.2 Abbreviations

For the purposes of the present document, the following abbreviations apply.

3GPP	Third Generation Partnership Project
ASP	Abstract Services Primitives
ATM	Abstract Test Method
ATS	Abstract Test Suite
BR	Border Router
CPE	Customer Premises Equipment
DHCP	Dynamic Host Configuration Protocol
DNS	Domain Name System
FTP	File Transfer Protocol
GRT	Global Routing Table
HTML	HyperText Markup Language
HTTP	HyperText Transfer Protocol
IP	Internet Protocol
IPv4	IP version 4
IPv6	IP version 6
IUT	Implementation Under Test
MAP-E	Mapping of Address and Port with Encapsulation (MAP)
MSS	Maximum Segment Size
MTC	Main Test Component
MTS	Methods for Testing and Specification
OSI	Open System Interconnection
PA	Platform Adaptor
PDU	Protocol Data Unit
PICS	Protocol Implementation Conformance Statement
PIXIT	Protocol Implementation Extra Information for Testing
PTC	Parallel Test Components
SUT	System Under Test
TA	Test Adaptor
TC	Test Case
TP	Test Purpose
TSS	Test Suite Structure
TTCN	Testing and Test Control Notation
VRF	Virtual Routing and Forwarding

4 Abstract test method

This clause describes the ATM used to test the MAP-E technology.

4.1 Abstract protocol tester

An abstract protocol tester presented in figure 1 is a process providing the test behaviour for testing an IUT. Thus it will emulate an entity which is capable of proving the IUT functionalities. This type of test architecture provides a situation of communication which is equivalent to real operation between real devices. The test system will simulate valid and invalid behaviours, and will analyse the reaction of the IUT. Then the test verdict, e.g. pass or fail, will depend on the result of this analysis. Thus this type of test architecture enables to focus the test objective on the IUT behaviour only.

In order to access an IUT, the corresponding abstract protocol tester needs to use lower layers to establish a proper connection to the system under test (SUT) over a physical link (Lower layers link).

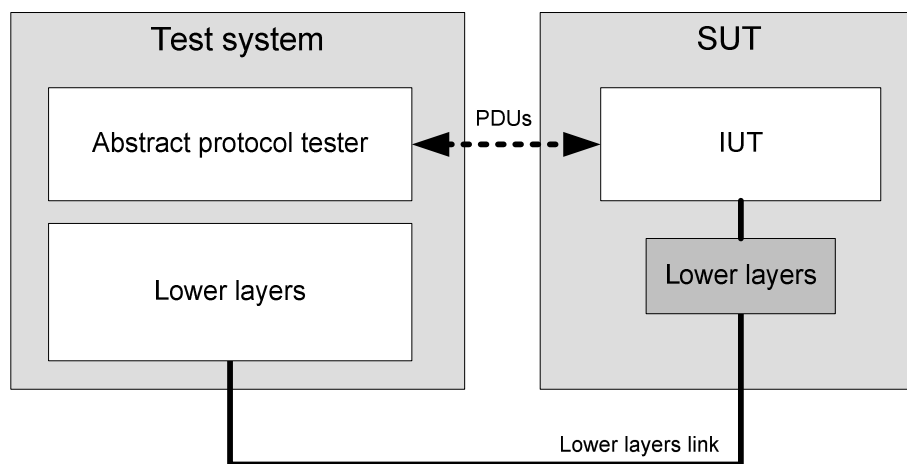

Figure 1: Generic abstract protocol tester

The "Protocol Data Units" (PDUs) are the messages exchanged between the IUT and the abstract protocol tester which permits to trigger the IUT and to analyse its reaction. The result of the analysis allows to assign the test verdict.

Further control actions on the IUT may be necessary from inside the SUT, for instance to simulate a primitive from the upper layer or the management/security entity. Further details on such control actions are provided by means of an upper tester presented in clause 4.3.

The above "Abstract Test Method" (ATM) is well defined in ISO/IEC 9646-1 [2] and supports a wide range of approaches for testing including the TTCN-3 abstract test language [7].

The abstract protocol tester used for MAP-E test suite is described in figure 2. The test system will send and receive IP packets, by using other upper layer protocols such as DHCP, DNS and FTP, in order to analyse MAP-E functionality.

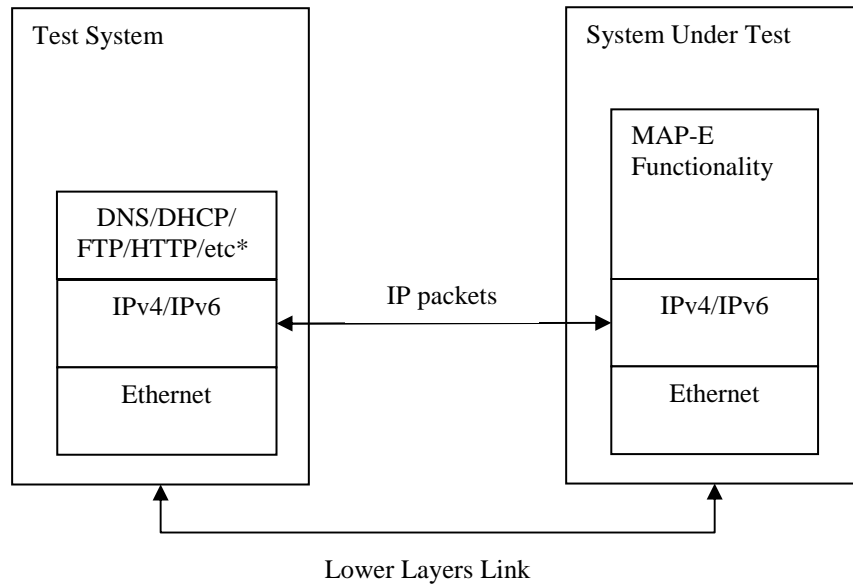

NOTE: * Those protocols are used to prove certain MAP-E functionalities.

Figure 2: Abstract Protocol Tester - MAP-E

4.2 Test configurations

The test suite for MAP-E uses two test configurations in order to cover the different test scenarios. Distinction between the two configurations is given by the two main components in MAP-E, which are BR and CPE.

4.2.1 CF01: BR as IUT

In this configuration, the BR is the IUT and the test system simulates an CPE in one side and a IPv4 host in the other side.

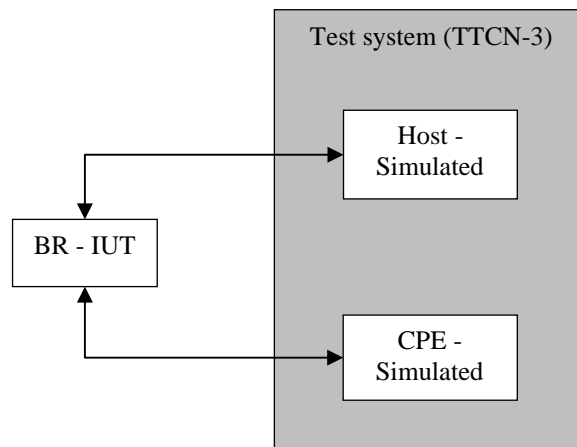

Figure 3: CF01, BR equipment is the IUT

4.2.2 CF02: CPE as IUT

In this configuration, the CPE is the IUT and the test system simulates a BR equipment in one side and an IPv4 host in the other side.

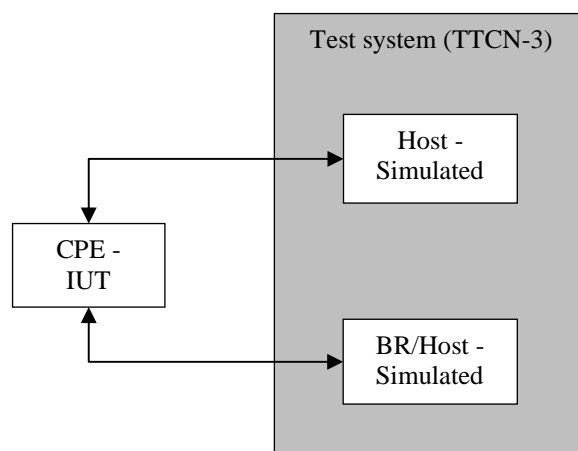

Figure 4: CF02, CPE equipment is the IUT

4.3 TTCN-3 Test architecture

In general, a conformance test system architecture based on TTCN-3 is as figure 5 shows.

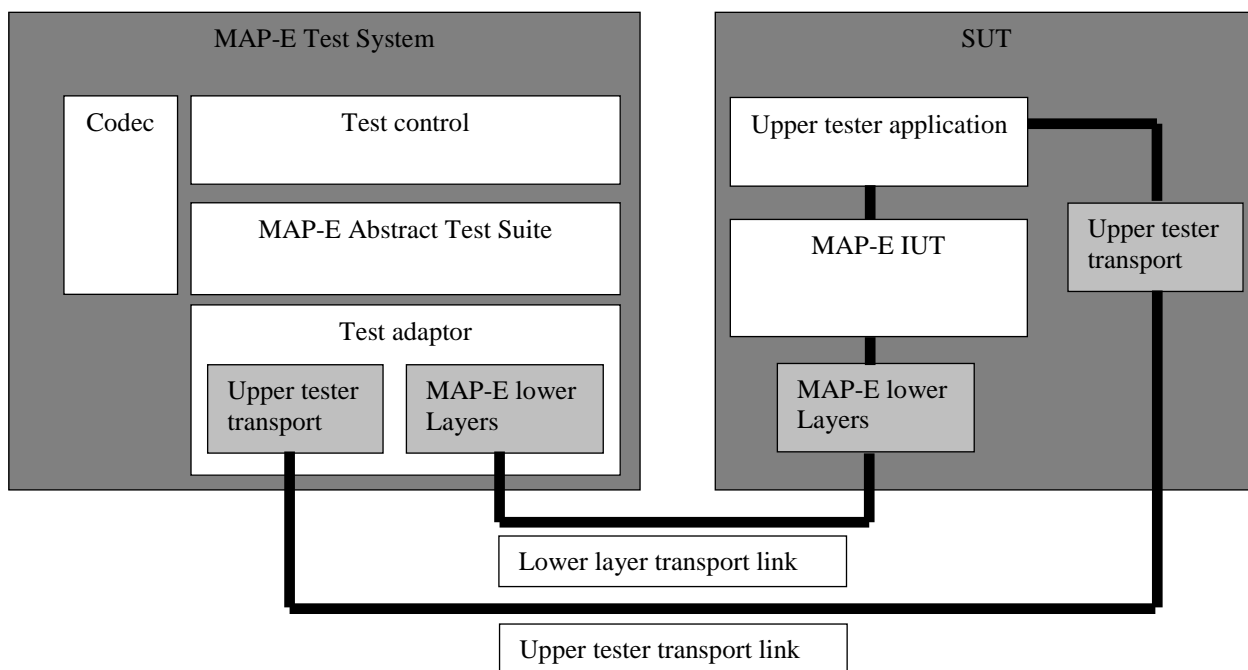

Figure 5: Global test architecture

The "System Under Test" (SUT) contains:

- The "Implementation Under Test" (IUT), i.e. the object of the test.
- The "Upper tester application" enables to trigger or capture some actions (i.e. higher layer service primitives) on the IUT.
- The "MAP-E lower layers" enable to establish a proper connection to the system under test (SUT) over a physical link (Lower layer transport link).

- The "Upper tester transport" is a functionality, which enables the test system to communicate with the upper tester application. Then the upper tester can be controlled by a TTCN-3 test component as part of the test process.

The "MAP-E test system" contains:

- The "TTCN-3 test components" are processes providing the test behaviour. The test behaviour may be provided as one single process or may require several independent processes.
- The "Codec" is a functional part of the test system to encode and decode messages between the TTCN-3 internal data representation and the format required by the related base standard.
- The "Test Control" enables the management of the TTCN-3 test execution (parameter input, logs, test selection, etc.).
- The "Test adaptor" (TA) realizes the interface between the TTCN-3 ports using TTCN-3 messages, and the physical interfaces provided by the IUT.

Based on the above test architecture, figure 5 shows a detailed test architecture used for the MAP-E. The MAP-E ATS requires using several Parallel Test Components (PTC) dealing with specific communication protocols and a Main Test Component (MTC) dealing with PTCs' synchronization. The different test components communicate with the MAP-E SUT over several ports (described in clause 4.4) which are used to exchange protocol messages between the test components and the MAP-E IUT.

The Upper tester entity enables triggering some functionalities by simulating actions or primitives from above applications.

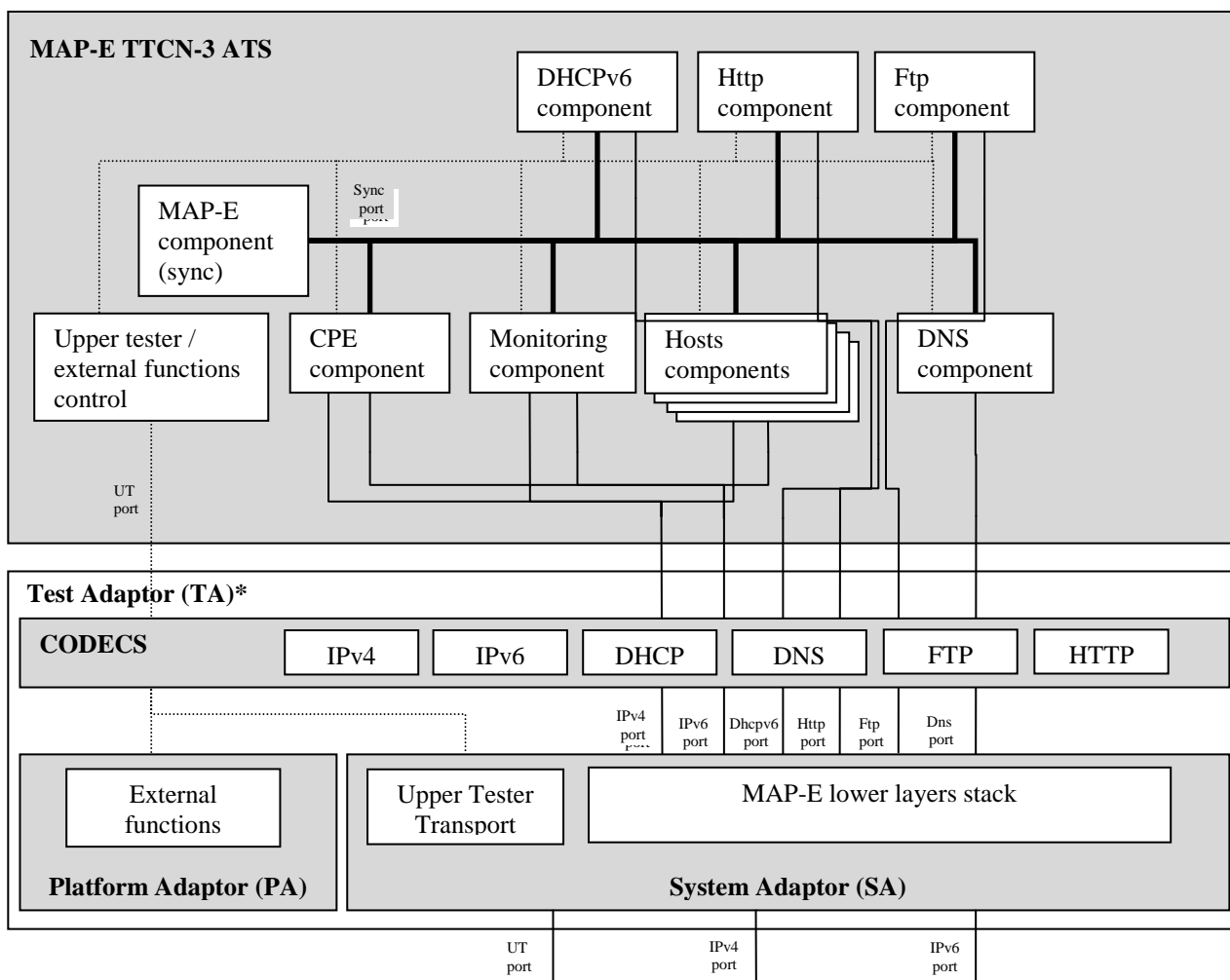

NOTE: * Test Adaptor (TA) is out of scope.

Figure 6: MAP-E TTCN-3 test architecture

The following protocol test components are available. Each of these components can be mapped to either a "Main Test Component" (MTC), when only one component shall be executed, or to a "Parallel Test Component" (PTC), if several components shall be used.

- **CPE:** This component simulates a MAP-E CPE entity and its functionality.
- **HOST:** These components simulate one or more hosts (one component per host).
- **MONITORING:** This component is used to monitor traffic from the IUT.
- **DNS:** This component simulates a DNS Client.
- **DHCP:** This component simulates a DHCPv6 Client.
- **FTP:** This component simulates a FTP client.
- **HTTP:** This component simulates a HTTP client.

The **Sync** component is mapped to the MTC and is used to trigger and synchronize the PTCs in order to orchestrate the test environment executed by the PTCs. In addition, it starts and terminates the test cases.

The **upper tester external functions control** represents the functions which the protocol test components may use to control the upper tester which is located in the SUT. These functions may use either external functions or dedicated messages and a dedicated port to realise synchronization. These functions can be executed in the protocol test components.

4.4 Ports and ASPs (Abstract Services Primitives)

4.4.1 TTCN-3 ports

The MAP-E Test Suite implements the following ports:

- **Ipv6Port**, to send and receive IPv6 packets.
- **Ipv4Port**, to send and receive IPv4 packets.
- **DnsPort**, to send and receive DNS messages.
- **Dhcpv6Port**, to send and receive DHCPv6 messages.
- **FtpPort**, to trigger the following FTP actions: login, logout, and data sending (both IPv4 and IPv6). It can monitor incoming traffic.
- **HttpPort**, to trigger the following HTTP actions: data sending (both IPv4 and IPv6). It can monitor incoming traffic.
- **UtPort**, included in order to be able to stimulate the IUT and receive extra information from IUT upper layers (it is not used in the current implementation and is provided for future expansion).

4.4.2 Abstract Service Primitives

Abstract service primitives are commands or actions that need to be performed on the IUT in order to trigger certain behaviour or to obtain information about the IUT state.

The list of ASP used in the MAP-E ATS is shown in table 1.

Table 1: MAP-E Abstract Service Primitives

TTCN-3 text	Action/Command	Description
Are routing tables configured GRT upstream ingress & VRF upstream egress?	Action	To check that routing tables are properly configured
Is Gateway Prefix withdrawn?	Action	To check that the gateway prefix is withdrawn
Remove the route	Command	To remove the route from IUT routing tables
Remove the cache	Command	To remove the IUT cache

5 Implemented Test Purposes

Table 2 shows the test purposes from ETSI TS 103 239-2 [10] which have been implemented and included in the present document.

Table 2: Implemented Test Purposes

TP Identifier	TC Identifier	Group	Subgroup	PICS	Untestable	Implemented		
TP/MAP-E/BR/BF/BV/01	TC_MAPE_BR_BF_BV_01	BR	Basic Function	PICS_ROLE_IS_BR		Yes		
TP/MAP-E/BR/AS/BV/01	TC_MAPE_BR_AS_BV_01		Address Structure		PICS_ROLE_IS_BR		Yes	
TP/MAP-E/BR/AS/BV/02	TC_MAPE_BR_AS_BV_02				PICS_ROLE_IS_BR		Yes	
TP/MAP-E/BR/AS/BV/03	TC_MAPE_BR_AS_BV_03				PICS_ROLE_IS_BR, PICS_PORT_RANGE		Yes	
TP/MAP-E/BR/SC/BV/01	TC_MAPE_BR_SC_BV_01		Session Control		PICS_ROLE_IS_BR		Yes	
TP/MAP-E/BR/AA/BV/01	TC_MAPE_BR_AA_BV_01		Anycast Addressing		PICS_ROLE_IS_BR		Yes	
TP/MAP-E/BR/MSSC/BV/01	TC_MAPE_BR_MSSC_BV_01		MSS Clamping		PICS_ROLE_IS_BR		Yes	
TP/MAP-E/BR/FRAG/BV/01	TC_MAPE_BR_FRAG_BV_01		Fragmentation		PICS_ROLE_IS_BR		Yes	
TP/MAP-E/CPE/GWA/BV/01	TC_MAPE_BR_GWA_BV_01		CPE	Gateway Addressing		PICS_ROLE_IS_CPE		Yes
TP/MAP-E/CPE/GWA/BV/02	TC_MAPE_BR_GWA_BV_02					PICS_ROLE_IS_CPE		Yes
TP/MAP-E/CPE/BF/BV/01	TC_MAPE_BR_BF_BV_01	Basic Function			PICS_ROLE_IS_CPE		Yes	
TP/MAP-E/CPE/AS/BV/01	TC_MAPE_BR_AS_BV_01	Address Structure			PICS_ROLE_IS_CPE		Yes	
TP/MAP-E/CPE/FRAG/BV/01	TC_MAPE_BR_FRAG_BV_01	Fragmentation			PICS_ROLE_IS_CPE		Yes	
TP/MAP-E/CPE/MSSC/BV/01	TC_MAPE_BR_MSSC_BV_01	MSS Clamping			PICS_ROLE_IS_CPE		Yes	
TP/MAP-E/CPE/SC/BV/01	TC_MAPE_BR_SC_BV_01	Session Control			PICS_ROLE_IS_CPE, PICS_PORT_RANGE		Yes	

6 ATS conventions

The ATS conventions are intended to give a better understanding of the ATS but they also describe the conventions made for the development of the ATS. These conventions shall be considered during any later maintenance or further development of the ATS.

6.1 Naming conventions

This test suite follows the naming convention guidelines provided in ETSI ETS 300 406 [6] and ETSI EG 202 798 [i.1].

6.1.1 General guidelines

The naming convention is based on the following underlying principles:

- Identifiers should be prefixed with a short alphabetic string (specified in table 3) indicating the type of TTCN-3 element it represents.
- Suffixes should not be used except in those specific cases identified in table 3.
- Prefixes and suffixes should be separated from the body of the identifier with an underscore ("_").

EXAMPLE 1: c_sixteen, t_wait.

- Only module names, data type names and module parameters should begin with an upper-case letter. All other names (i.e. the part of the identifier following the prefix) should begin with a lower-case letter.
- The start of second and subsequent words in an identifier should be indicated by capitalizing the first character. Underscores should not be used for this purpose.

EXAMPLE 2: f_initialState.

Table 3 specifies the naming guidelines for each element of the TTCN-3 language indicating the recommended prefix, suffixes (if any) and capitalization.

Table 3: ETSI TTCN-3 generic naming conventions

Language element	Naming convention	Prefix	Example identifier
Module	Use upper-case initial letter	AtsMapE_	AtsMapE_Templates
Group within a module	Use lower-case initial letter	none	aftrSut
Data type	Use upper-case initial letter	none	SetupContents
Message template	Use lower-case initial letter	m_	m_ipv4Packet_dummy
Message template with wildcard or matching expression	Use lower-case initial letters	mw_	mw_dns_dummy
Modifying message template	Use lower-case initial letter	md_	md_setupInit
Modifying message template with wildcard or matching expression	Use lower-case initial letters	mdw_	mdw_dnsData_query
Signature template	Use lower-case initial letter	s_	s_callSignature
Port instance	Use lower-case initial letter	none	dnsPort
Test component instance	Use lower-case initial letter	none	HostComponent
Constant	Use lower-case initial letter	c_	c_portExt
Constant (defined within component type)	Use lower-case initial letter	cc_	cc_minDuration
External constant	Use lower-case initial letter	cx_	cx_macId
Function	Use lower-case initial letter	f_	f_cf01Up()
External function	Use lower-case initial letter	fx_	fx_calculateLength()
Altstep (incl. Default)	Use lower-case initial letter	a_	a_default()
Test case	Use ETSI numbering	TC_	TC_MAP_E_BR_SC_BV_001
Variable (local)	Use lower-case initial letter	v_	v_dhcpMessage
Variable (defined within a component type)	Use lower-case initial letters	vc_	vc_aftrComponent
Timer (local)	Use lower-case initial letter	t_	t_wait
Timer (defined within a component)	Use lower-case initial letters	tc_	tc_ac
Module parameters for PICS	Use all upper case letters	PICS_	PICS_ROLE_RH
Module parameters for other parameters	Use all upper case letters	PX_	PX_LINK_ID
Formal Parameters	Use lower-case initial letter	p_	p_commRef
Enumerated Values	Use lower-case initial letter	e_	e_success

6.1.2 MAP-E specific TTCN-3 naming conventions

In addition to such general naming conventions, table 4 shows specific naming conventions that apply to the MAP-E technology TTCN-3 test suite.

Table 4: MAP-E specific TTCN-3 naming conventions

Language element	Naming convention	Prefix	Example identifier
MAP-E Module	Use upper-case initial letter	AtsMapE_	AtsMapE_
Module containing types and values	Use upper-case initial letter	AtsMapE_TypesAndValues	AtsMapE_TypesAndValues
Module containing Templates	Use upper-case initial letter	AtsMapE_Templates	AtsMapE_Templates
Module containing test cases	Use upper-case initial letter	AtsMapE_TestCases	AtsMapE_TestCases
Module containing functions	Use upper-case initial letter	AtsMapE_Functions	AtsMapE_Functions
Module containing external functions	Use upper-case initial letter	AtsMapE_ExternalFunctions	AtsMapE_ExternalFunctions
Module containing components, ports and message definitions	Use upper-case initial letter	AtsMapE_Interfaces	AtsMapE_Interfaces
Module containing main component definitions	Use upper-case initial letter	AtsMapE_TestSystem	AtsMapE_TestSystem
Module containing the control part	Use upper-case initial letter	AtsMapE_TestControl	AtsMapE_TestControl

6.1.3 Usage of Log statements

All TTCN-3 log statements use the following format:

- Three asterisks followed by a blank character.
- The TTCN-3 test case or function identifier in which the log statement is defined followed by a colon and a blank character.
- One of the log categories: INFO, WARNING, ERROR, PASS, FAIL, INCONC, TIMEOUT followed by a colon and a blank character.
- Free text.
- A blank character followed by three asterisks.

EXAMPLE 1: `log("***TC_MAPE_BR_SC_BV_01: INFO: Preamble: IUT was setup properly ***").`

Furthermore, the following rules are applied for this ATS:

- Log statements are used in the body of the functions, so that invocation of functions are visible in the test logs.
- All TTCN-3 setverdict statements are combined (as defined in TTCN-3) with a log statement following the same above rules (see example 2).

EXAMPLE 2: `setverdict(pass, "*** TC_MAPE_BR_SC_BV_01: PASS: IPv4 packet was forwarded ***").`

6.1.4 Test Case (TC) identifier

The identifier of the TC is built according to table 5 as recommended in ETSI ETS 300 406 [6].

Table 5: TC naming convention for MAP-E

TC_<root>_<gr>_<sgr>_<x>_<nn>		
<root> = root	MAP-E	MAP with Encapsulation
<gr> = group	BR	BR as IUT
	CPE	CPE as IUT
<sgr> = sub-group	GWA	Gateway Assignment
	BF	Basic Function
	FRAG	Fragmentation
	AS	Address Structure
	MSSC	Maximum Segment Size Clamping
	SC	Session Control
	AA	Anycast Addressing
<x> = type of testing	BV	Valid Behaviour tests
	TI	Timer Tests
<nn> = sequential number		01 to 99
NOTE: A sub-group may not apply for all groups.		

EXAMPLE: TP identifier: TP/MAPE/BR/SC/BV/01 or TP/MAPE/BR/MSSC/BV/01
 TC identifier: TC_MAPE_BR_SC_BV_01 or TC_MAPR_BR_MSSC_BV_01.

6.2 On line documentation

Using the T3D tool enables providing on-line documentation browser in HTML, by tagging TTCN-3 comments. These tags are defined in table 6.

Table 6: TTCN-3 comment tags

Tag	Description
@author	Specifies the names of the authors or an authoring organization which either has created or is maintaining a particular piece of TTCN-3 code.
@desc	Describes the purpose of a particular piece of TTCN-3 code. The description should be concise yet informative and describe the function and use of the construct.
@remark	Adds extra information, such as the highlighting of a particular feature or aspect not covered in the description.
@see	Refers to other TTCN-3 definitions in the same or another module.
@return	Provides additional information on the value returned by a given function.
@param	Documents the parameters of parameterized TTCN-3 definitions.
@version	States the version of a particular piece of TTCN-3 code.

The HTML files result from the compilation of the TTCN-3 modules with the T3Doc tool. These HTML files are ready for browsing, and contains links enabling to navigate through the ATS.

EXAMPLE:

```
/**
 * @desc    Check that IUT supports the functionality of MAP-E base NAT mapp
 * @version 0.0.1
 * @see     RFC2473 TP/MAP-E/BR/BF/BV/01
 */
```

Annex A (normative): Partial PIXIT proforma for MAP-ETSI

Notwithstanding the provisions of the copyright clause related to the text of the present document, ETSI grants that users of the present document may freely reproduce the Partial PIXIT proforma in this annex so that it can be used for its intended purposes and may further publish the completed Partial PIXIT.

A.1 Identification summary

Table A.1

PIXIT Number:	
Test Laboratory Name:	
Date of Issue:	
Issued to:	

A.2 ATS summary

Table A.2: Summary

Protocol Specification:	
Protocol to be tested:	
ATS Specification:	
Abstract Test Method:	

A.3 Test laboratory

Table A.3: Test laboratory

Test Laboratory Identification:	
Test Laboratory Manager:	
Means of Testing:	
SAP Address:	

A.4 Client identification

Table A.4: Client identification

Client Identification:	
Client Test manager:	
Test Facilities required:	

A.5 SUT

Table A.5: SUT identification

Name:	
Version:	
SCS Number:	
Machine configuration:	
Operating System Identification:	
IUT Identification:	
PICS Reference for IUT:	
Limitations of the SUT:	
Environmental Conditions:	

A.6 Protocol layer information

A.6.1 Protocol identification

Table A.6: Protocol identification

Name:	
Version:	
PICS References:	

A.6.2 IUT information

Table A.7: MAP-E Pixits

Identifier	Description	
PX_MAPE_PREFIX	Comment	Defines the NAT64 prefix
	Type	Ipv4Address
	Def. value	'0064FF9B00000000'O
PX_BR_GW_IPv6_ADDRESS	Comment	indicates the IPv6 address of the BR equipment
	Type	Ipv6Address
	Def. value	0
PX_MAPE_IPv6_ANYCAST_ADDRESS	Comment	Anycast address
	Type	Ipv6Address
	Def. value	0
PX_IPv4_UNKNOWN_DESTINATION_INFORMATION	Comment	Unknown destination description
	Type	Ipv6Address
	Def. value	0
PX_IPv4_PRIVATE_DESTINATION_INFORMATION	Comment	Private host description
	Type	
	Def. value	
PX_IPv4_DESTINATION_INFORMATION_PORT_RANGE	Comment	Defines a list of IPv4 host services
	Type	
	Def. value	
PX_MAPE_MAPPING_TABLE_A_PLUS_P	Comment	Address + Port mapping for hosts
	Type	
	Def. value	
PX_MULTIPLE_HOSTS_V4_IN_V6	Comment	Defines a list of host services to be used for IPv4 in IPv6
	Type	
	Def. value	
PX_MAPE_MSS_SIZE	Comment	The MSS value
	Type	UInt
	Def. value	1500
PX_MAPE_TUNNEL_MTU	Comment	The MAPE-Tunnel-MTU value
	Type	UInt
	Def. value	1500
PX_IUT_PORT_RANGE	Comment	he IPv4 address of an FTP server
	Type	Ipv4Address
	Def. value	0

Annex B (normative): PCTR Proforma for MAP-E

Notwithstanding the provisions of the copyright clause related to the text of the present document, ETSI grants that users of the present document may freely reproduce the PCTR proforma in this annex so that it can be used for its intended purposes and may further publish the completed PCTR.

The PCTR proforma is based on ISO/IEC 9646-6 [4]. Any needed additional information can be found in this International standard document.

B.1 Identification summary

B.1.1 Protocol conformance test report

Table B.1

PCTR Number:	
PCTR Date:	
Corresponding SCTR Number:	
Corresponding SCTR Date:	
Test Laboratory Identification:	
Test Laboratory Manager:	
Signature:	

B.1.2 IUT identification

Table B.2

Name:	
Version:	
Protocol specification:	
PICS:	
Previous PCTR if any:	

B.1.3 Testing environment

Table B.3

PIXIT Number:	
ATS Specification:	
Abstract Test Method:	
Means of Testing identification:	
Date of testing:	
Conformance Log reference(s):	
Retention Date for Log reference(s):	

B.1.4 Limits and reservation

Additional information relevant to the technical contents or further use of the test report, or the rights and obligations of the test laboratory and the client, may be given here. Such information may include restriction on the publication of the report.

.....

.....

.....

.....

.....

.....

B.1.5 Comments

Additional comments may be given by either the client or the test laboratory on any of the contents of the PCTR, for example, to note disagreement between the two parties.

.....

.....

.....

.....

.....

.....

B.2 IUT Conformance status

This IUT has or has not been shown by conformance assessment to be non-conforming to the specified protocol specification.

Strike the appropriate words in this sentence. If the PICS for this IUT is consistent with the static conformance requirements (as specified in clause B.3 in the present document) and there are no "FAIL" verdicts to be recorded (in clause B.6 in the present document) strike the words "has or", otherwise strike the words "or has not".

B.3 Static conformance summary

The PICS for this IUT is or is not consistent with the static conformance requirements in the specified protocol.

Strike the appropriate words in this sentence.

B.4 Dynamic conformance summary

The test campaign did or did not reveal errors in the IUT.

Strike the appropriate words in this sentence. If there are no "FAIL" verdicts to be recorded (in clause B.6 of the present document) strike the words "did or" otherwise strike the words "or did not".

Summary of the results of groups of test:

.....

.....

.....

.....

.....

.....

.....

.....

.....

.....

B.5 Static conformance review report

If clause B.3 indicates non-conformance, this clause itemizes the mismatches between the PICS and the static conformance requirements of the specified protocol specification.

.....

.....

.....

.....

.....

.....

.....

.....

.....

.....

.....

.....

.....

.....

.....

.....

.....

.....

.....

.....

.....

.....

.....

B.7 Observations

Additional information relevant to the technical content of the PCTR is given here.

.....

.....

.....

.....

.....

.....

.....

.....

.....

.....

.....

.....

.....

.....

.....

.....

.....

.....

.....

.....

.....

Annex C (normative): TTCN-3 library modules

This ATS has been produced using the Testing and Test Control Notation (TTCN) according to ETSI ES 201 873-1 [7]. The ATS was developed on a separate TTCN software tool and therefore the TTCN tables are not completely referenced in the table of contents. The ATS itself contains a test suite overview part which provides additional information and references.

This test suite has been compiled error-free using three different commercial TTCN-3 compilers.

C.1 Electronic annex, zip file with TTCN-3 code

The TTCN-3 library modules, which form parts of the present document, are contained in archive `ts_10323903v010101p0.zip` which accompanies the present document.

Annex D (informative): Bibliography

- ETSI ES 201 873-7: "Methods for Testing and Specification (MTS); The Testing and Test Control Notation version 3; Part 7: Using ASN.1 with TTCN-3".
- ETSI TS 103 239-1: "Integrated broadband cable telecommunication networks (CABLE) Testing; Conformance test specifications for MAP-E technology; Part 1: Test requirements and Protocol Implementation Conformance Statement (PICS) proforma".

History

Document history		
V1.1.1	December 2014	Publication