

ETSI TS 103 120 V1.4.1 (2019-12)



TECHNICAL SPECIFICATION

Lawful Interception (LI); Interface for warrant information

Reference

RTS/LI-00172

Keywords

eWarrant, lawful disclosure, lawful interception,
warrant, warrantry

ETSI

650 Route des Lucioles
F-06921 Sophia Antipolis Cedex - FRANCE

Tel.: +33 4 92 94 42 00 Fax: +33 4 93 65 47 16

Siret N° 348 623 562 00017 - NAF 742 C
Association à but non lucratif enregistrée à la
Sous-Préfecture de Grasse (06) N° 7803/88

Important notice

The present document can be downloaded from:

<http://www.etsi.org/standards-search>

The present document may be made available in electronic versions and/or in print. The content of any electronic and/or print versions of the present document shall not be modified without the prior written authorization of ETSI. In case of any existing or perceived difference in contents between such versions and/or in print, the prevailing version of an ETSI deliverable is the one made publicly available in PDF format at www.etsi.org/deliver.

Users of the present document should be aware that the document may be subject to revision or change of status.

Information on the current status of this and other ETSI documents is available at

<https://portal.etsi.org/TB/ETSIDeliverableStatus.aspx>

If you find errors in the present document, please send your comment to one of the following services:

<https://portal.etsi.org/People/CommiteeSupportStaff.aspx>

Copyright Notification

No part may be reproduced or utilized in any form or by any means, electronic or mechanical, including photocopying and microfilm except as authorized by written permission of ETSI.

The content of the PDF version shall not be modified without the written authorization of ETSI.

The copyright and the foregoing restriction extend to reproduction in all media.

© ETSI 2019.

All rights reserved.

DECT™, **PLUGTESTS™**, **UMTS™** and the ETSI logo are trademarks of ETSI registered for the benefit of its Members.

3GPP™ and **LTE™** are trademarks of ETSI registered for the benefit of its Members and of the 3GPP Organizational Partners.

oneM2M™ logo is a trademark of ETSI registered for the benefit of its Members and of the oneM2M Partners.

GSM® and the GSM logo are trademarks registered and owned by the GSM Association.

Contents

Intellectual Property Rights	7
Foreword.....	7
Modal verbs terminology.....	7
Executive summary	7
Introduction	7
1 Scope	8
2 References	8
2.1 Normative references	8
2.2 Informative references.....	9
3 Definition of terms, symbols and abbreviations.....	10
3.1 Terms.....	10
3.2 Symbols.....	10
3.3 Abbreviations	10
4 Structure and model.....	11
4.1 Structure of the standard.....	11
4.2 Structure of the present document	11
4.3 Reference model.....	12
5 Message Exchange	13
6 Message Structure	13
6.1 Overview	13
6.2 Message Header	14
6.2.1 Introduction.....	14
6.2.2 Structure.....	14
6.2.3 Version.....	14
6.2.4 EndpointID	15
6.2.5 Transaction Identifiers	15
6.3 Message Payload	16
6.3.1 Introduction.....	16
6.3.2 Request Payload.....	16
6.3.3 Response Payload	16
6.4 Action Request and Responses.....	16
6.4.1 Overview	16
6.4.2 Action Requests	16
6.4.3 Action Responses.....	17
6.4.4 Action Identifiers	17
6.4.5 GET	17
6.4.6 CREATE.....	18
6.4.7 UPDATE	18
6.4.8 LIST.....	19
6.4.9 Action Unsuccessful Information	20
6.4.10 DELIVER	21
7 Data Definitions	21
7.1 HI-1 Object.....	21
7.1.1 Overview	21
7.1.2 ObjectIdentifier.....	22
7.1.3 Generation.....	22
7.1.4 AssociatedObjects.....	22
7.1.5 LastChanged	22
7.1.6 NationalHandlingParameters	22
7.2 Authorisation Object	22
7.2.1 Overview	22

7.2.2	AuthorisationReference	23
7.2.3	AuthorisationLegalType	23
7.2.4	AuthorisationPriority	24
7.2.5	AuthorisationStatus.....	24
7.2.6	AuthorisationDesiredStatus	25
7.2.7	AuthorisationTimespan.....	25
7.2.8	AuthorisationCSPID	25
7.2.9	AuthorisationCreationTimestamp.....	25
7.2.10	AuthorisationServedTimestamp	25
7.2.11	AuthorisationApprovalDetails	25
7.2.12	AuthorisationFlags.....	26
7.3	Document Object.....	26
7.3.1	Overview	26
7.3.2	DocumentReference.....	27
7.3.3	DocumentName	27
7.3.4	DocumentStatus	27
7.3.5	DocumentDesiredStatus.....	27
7.3.6	DocumentTimespan	28
7.3.7	DocumentType	28
7.3.8	DocumentProperties.....	28
7.3.9	DocumentBody	28
7.3.10	DocumentSignature	29
7.4	Notification Object.....	29
7.4.1	Overview	29
7.4.2	NotificationDetails.....	30
7.4.3	NotificationType.....	30
7.4.4	NewNotification	30
7.4.5	NotificationTimestamp	30
7.4.6	NationalNotificationParameters.....	30
8	Task Objects	31
8.1	Overview	31
8.2	LITaskObject.....	31
8.2.1	Overview	31
8.2.2	Reference	32
8.2.3	Status	32
8.2.4	DesiredStatus	32
8.2.5	TimeSpan.....	33
8.2.6	TargetIdentifier	33
8.2.6.1	Overview	33
8.2.6.2	TargetIdentifierValues Field	33
8.2.6.3	FormatType	34
8.2.6.4	Task Service Type.....	34
8.2.7	DeliveryType	34
8.2.8	TaskDeliveryDetails	35
8.2.8.1	Overview.....	35
8.2.8.2	DeliveryDestination	35
8.2.8.3	DeliveryAddress.....	36
8.2.8.4	HandoverFormat	36
8.2.9	ApprovalDetails	36
8.2.10	CSPID.....	36
8.2.11	HandlingProfile.....	36
8.2.12	Flags.....	36
8.3	LDTaskObject	37
8.3.1	Overview	37
8.3.2	Reference	37
8.3.3	Status	38
8.3.4	DesiredStatus	38
8.3.5	RequestDetails	38
8.3.5.1	Overview.....	38
8.3.5.2	Type	39
8.3.5.3	RequestValues.....	39

8.3.5.4	FormatType	40
8.3.6	DeliveryDetails	40
8.3.6.1	Overview	40
8.3.6.2	LDDeliveryDestination	41
8.3.6.3	HandoverFormat	41
8.3.7	Flags.....	41
9	Transport and Encoding	42
9.1	Overview	42
9.2	Encoding.....	42
9.2.1	XML Schema.....	42
9.2.2	Error conditions	42
9.2.3	Message signing and encryption	42
9.3	HTTP Transport	42
9.3.1	Use of HTTP.....	42
9.3.2	Client/Server architecture	42
9.3.3	HTTP Configuration	42
9.3.4	Transport security	43
9.4	Nationally-defined Transport	43
10	Delivery Object	43
10.1	Overview	43
10.2	DeliveryObject	43
10.2.1	Overview	43
10.2.2	Manifest	44
10.2.3	Delivery	44
Annex A (informative): Example usage scenarios for HI-1		46
A.1	Overview	46
A.2	Direct communication	46
A.3	Single "Central Authority"	46
A.4	Multiple Approving Authorities.....	47
A.4.1	Overview	47
A.4.2	"Serial" interaction	47
A.4.3	"Parallel" interaction	48
Annex B (informative): Example Template National Profile		50
B.1	Introduction	50
B.1.1	Overview	50
B.1.2	Structure of this annex.....	50
B.1.3	Checklist for National Profile authors	50
B.1.4	Details of the fictional national jurisdiction	51
B.2	Example National Profile	52
B.2.1	Approach and reference model.....	52
B.2.1.1	Overview	52
B.2.1.2	Warrants.....	52
B.2.1.3	Tasking Instructions.....	52
B.2.1.4	Representation by HI-1 Objects.....	53
B.2.2	Message Structure	53
B.2.2.1	Overview	53
B.2.2.2	Version information.....	53
B.2.2.3	Sender and Receiver Identifiers	53
B.2.2.4	LIST semantics	53
B.2.3	Data Definitions	54
B.2.3.1	Overview	54
B.2.3.2	Object Identifiers	54
B.2.3.3	Generic Object Fields	54
B.2.3.4	Authorisation Objects	54
B.2.3.5	Document Objects	55

B.2.3.6	Notification Objects	56
B.2.3.7	LITaskObjects	56
B.2.4	Transport and Encoding	57
B.2.5	Example XML	57
B.2.5.1	Introduction	57
B.2.5.2	Void	58
B.2.5.3	Void	58
B.2.5.4	Void	58
B.2.5.5	Void	58
B.2.5.6	Void	58
B.2.5.7	Void	58
Annex C (normative): ETSI Target Identifier and Request Value Format Definitions		59
C.1	Overview	59
C.2	Definitions	59
Annex D (normative): Error Codes		61
D.1	Detailed error codes	61
Annex E (normative): Approval Details		62
E.1	Overview	62
E.2	ApprovalType	62
E.3	ApprovalDescription	62
E.4	ApprovalReference	62
E.5	ApproverDetails	63
E.5.1	Overview	63
E.5.2	ApproverIdentity	63
E.6	ApprovalTimestamp	63
E.7	ApprovalIsEmergency	63
E.8	ApprovalDigitalSignature	64
E.8.1	Overview	64
Annex F (normative): Dictionaries		65
F.1	Overview	65
F.2	DictionaryEntry type	65
F.3	Definition and use of dictionaries	65
F.3.1	Overview	65
F.3.2	Owner	66
F.3.3	Name	66
F.3.4	Use of dictionaries	66
F.3.5	Machine-readable dictionary definitions	66
Annex G (normative): Drafting conventions for National Parameters		67
G.1	Overview	67
G.2	Drafting conventions	67
Annex H (informative): Bibliography		68
Annex I (informative): Change Request history		69
History	70

Intellectual Property Rights

Essential patents

IPRs essential or potentially essential to normative deliverables may have been declared to ETSI. The information pertaining to these essential IPRs, if any, is publicly available for **ETSI members and non-members**, and can be found in ETSI SR 000 314: *"Intellectual Property Rights (IPRs); Essential, or potentially Essential, IPRs notified to ETSI in respect of ETSI standards"*, which is available from the ETSI Secretariat. Latest updates are available on the ETSI Web server (<https://ipr.etsi.org/>).

Pursuant to the ETSI IPR Policy, no investigation, including IPR searches, has been carried out by ETSI. No guarantee can be given as to the existence of other IPRs not referenced in ETSI SR 000 314 (or the updates on the ETSI Web server) which are, or may be, or may become, essential to the present document.

Trademarks

The present document may include trademarks and/or tradenames which are asserted and/or registered by their owners. ETSI claims no ownership of these except for any which are indicated as being the property of ETSI, and conveys no right to use or reproduce any trademark and/or tradename. Mention of those trademarks in the present document does not constitute an endorsement by ETSI of products, services or organizations associated with those trademarks.

Foreword

This Technical Specification (TS) has been produced by ETSI Technical Committee Lawful Interception (LI).

Modal verbs terminology

In the present document **"shall"**, **"shall not"**, **"should"**, **"should not"**, **"may"**, **"need not"**, **"will"**, **"will not"**, **"can"** and **"cannot"** are to be interpreted as described in clause 3.2 of the [ETSI Drafting Rules](#) (Verbal forms for the expression of provisions).

"must" and **"must not"** are **NOT** allowed in ETSI deliverables except when used in direct citation.

Executive summary

The present document defines a protocol for the electronic exchange of legal and technical information for the purposes of establishing and managing lawfully required actions (e.g. Lawful Interception). In this phase, the present document is intended to provide the underlying functionality for HI-1, as defined in the ETSI LI Reference Model, and it has been designed for applicability beyond LI in future phases.

Introduction

The present document was constructed in multiple phases. The first phase of the present document consisted of a reference architecture. It was created by investigating current practices and procedures across TC LI. It makes clear the distinction between the process of communicating with the Communication Service Provider to inform them about the interception details (commonly called "tasking") and also communication among government/law enforcement/judiciary to establish the warrant (commonly called "warranting"). The second phase of the present document provided a standardized detailed interface based on the architecture in the first phase, in particular for LI. The present document anticipates that future phases will add other requests for legal action.

1 Scope

The present document defines an electronic interface between two systems for the exchange of information relating to the establishment and management of lawful required action, typically Lawful Interception. Typically this interface would be used between: on one side, a Communications Service Provider; and, on the other side, a Government or Law Enforcement Agency who is entitled to request a lawful action. The present document is a specific and detailed example of one particular Warrant interface for eWarrants [i.1].

The ETSI reference model for LI (ETSI TS 101 671 [1] or ETSI TS 102 232-1 [2]) defines three interfaces between law enforcement and CSPs, called HI-1, HI-2 and HI-3. The protocol defined in the present document is designed to provide a large part of the functionality for HI-1. It is not designed to be used for HI-2 (delivery of intercept related information) or HI-3 (delivery of communications content). The protocol designed in the present document may also be used for interfaces which require structured exchange of information relating to the establishment and management of Lawful Interception. The general view is that the HI-1 concept can also be used for other legal actions than LI. For that reason the present document could, besides LI, also be applied for retained data requests, seized data requests, data preservation orders and other similar legal requests.

2 References

2.1 Normative references

References are either specific (identified by date of publication and/or edition number or version number) or non-specific. For specific references, only the cited version applies. For non-specific references, the latest version of the referenced document (including any amendments) applies.

Referenced documents which are not found to be publicly available in the expected location might be found at <https://docbox.etsi.org/Reference/>.

NOTE: While any hyperlinks included in this clause were valid at the time of publication, ETSI cannot guarantee their long term validity.

The following referenced documents are necessary for the application of the present document.

- [1] ETSI TS 101 671: "Lawful Interception (LI); Handover interface for the lawful interception of telecommunications traffic".

NOTE: ETSI TS 101 671 is in status "historical" and is not maintained.

- [2] ETSI TS 102 232-1: "Lawful Interception (LI); Handover Interface and Service-Specific Details (SSD) for IP delivery; Part 1: Handover specification for IP delivery".
- [3] IETF RFC 4122: "A Universally Unique IDentifier (UUID) URN Namespace".
- [4] W3C Recommendation 26 November 2008: "Extensible Markup Language (XML) 1.0".
- [5] IETF RFC 2818: "HTTP over TLS".
- [6] IETF RFC 4279: "Pre-Shared Key Ciphersuites for Transport Layer Security (TLS)".
- [7] ETSI TS 103 280: "Lawful Interception (LI); Dictionary for common parameters".
- [8] IETF RFC 1738: "Uniform Resource Locators (URL)".

NOTE: Obsoleted by IETF RFC 4248 and IETF RFC 4266.

- [9] IETF RFC 2045: "Multipurpose Internet Mail Extensions (MIME) Part One: Format of Internet Message Bodies".
- [10] IETF RFC 2046: "Multipurpose Internet Mail Extensions (MIME) Part Two: Media Types".
- [11] IETF RFC 1321: "The MD5 Message-Digest Algorithm".

- [12] W3C Recommendation, 14 December 2017: "HTML 5.2".
- [13] IEEE POSIX 1003.1™-2017: "IEEE Standard for Information Technology--Portable Operating System Interface (POSIX(R)) Base Specifications, Issue 7".
- [14] ISO 3166-1: "Codes for the representation of names of countries and their subdivisions - Part 1: Country codes".
- [15] ETSI TS 102 232-2: "Lawful Interception (LI); Handover Interface and Service-Specific Details (SSD) for IP delivery; Part 2: Service-specific details for messaging services".
- [16] ETSI TS 102 232-3: "Lawful Interception (LI); Handover Interface and Service-Specific Details (SSD) for IP delivery; Part 3: Service-specific details for internet access services".
- [17] ETSI TS 102 232-4: "Lawful Interception (LI); Handover Interface and Service-Specific Details (SSD) for IP delivery; Part 4: Service-specific details for Layer 2 services".
- [18] ETSI TS 102 232-5: "Lawful Interception (LI); Handover Interface and Service-Specific Details (SSD) for IP delivery; Part 5: Service-specific details for IP Multimedia Services".
- [19] ETSI TS 102 232-6: "Lawful Interception (LI); Handover Interface and Service-Specific Details (SSD) for IP delivery; Part 6: Service-specific details for PSTN/ISDN services".
- [20] ETSI TS 102 232-7: "Lawful Interception (LI); Handover Interface and Service-Specific Details (SSD) for IP delivery; Part 7: Service-specific details for Mobile Services".
- [21] ETSI TS 123 501: "5G; System architecture for the 5G System (5GS) (3GPP TS 23.501)".
- [22] ETSI TS 102 657: "Lawful Interception (LI); Retained data handling; Handover interface for the request and delivery of retained data".
- [23] IETF RFC 6234: "US Secure Hash Algorithms (SHA and SHA-based HMAC and HKDF)".

2.2 Informative references

References are either specific (identified by date of publication and/or edition number or version number) or non-specific. For specific references, only the cited version applies. For non-specific references, the latest version of the referenced document (including any amendments) applies.

NOTE: While any hyperlinks included in this clause were valid at the time of publication, ETSI cannot guarantee their long term validity.

The following referenced documents are not necessary for the application of the present document but they assist the user with regard to a particular subject area.

- [i.1] ETSI TR 103 690: "Lawful Interception (LI); eWarrant Interface".
- [i.2] IETF RFC 3261: "SIP: Session Initiation Protocol".
- [i.3] IETF RFC 3966: "The tel URI for Telephone Numbers".
- [i.4] IETF RFC 3508: "H.323 Uniform Resource Locator (URL) Scheme Registration".
- [i.5] IETF RFC 4282: "The Network Access Identifier".
- [i.6] ETSI TS 123 003 (V13.4.0): "Digital cellular telecommunications system (Phase 2+) (GSM); Universal Mobile Telecommunications System (UMTS); Numbering, addressing and identification (3GPP TS 23.003 version 13.4.0 Release 13)".
- [i.7] ETSI TS 124 229 (V13.3.1): "Digital cellular telecommunications system (Phase 2+); Universal Mobile Telecommunications System (UMTS); IP multimedia call control protocol based on Session Initiation Protocol (SIP) and Session Description Protocol (SDP); Stage 3 (3GPP TS 24.229 version 13.3.1 Release 13)".

- [i.8] IEEE Std 802-2001™: "IEEE Standard for Local and Metropolitan Area Networks: Overview and Architecture".
- [i.9] Recommendation ITU-T E.164: "The international public telecommunication numbering plan".
- [i.10] Recommendation ITU-T E.212: "The international identification plan for public networks and subscriptions".

3 Definition of terms, symbols and abbreviations

3.1 Terms

For the purposes of the present document, the following terms apply:

Communications Service Provider (CSP): Network Operator (NWO) or Access Provider (AP) who is obliged by law to perform a lawful action in response to a Warrant (e.g. perform Lawful Interception)

Law Enforcement Agency (LEA): Government or Law Enforcement Agency who is entitled to request a lawful action

warrant: legal authorization to perform an action or set of actions

3.2 Symbols

Void.

3.3 Abbreviations

For the purposes of the present document, the following abbreviations apply:

CC	Content of Communication
CIDR	Classless InterDomain Routing
CSP	Communication Service Provider
CSPID	Communication Service Provider Identifier
ERE	Extended Regular Expression
FQDN	Fully Qualified Domain Name
FTP	File Transfer Protocol
HI	Handover Interface
HI-1	Handover Interface 1
HI-2	Handover Interface 2
HI-3	Handover Interface 3
HI-B	Handover Interface B
HTML	Hypertext Markup Language
HTTP	HyperText Transfer Protocol
IEEE	Institute of Electrical and Electronics Engineers
IMEI	International Mobile station Equipment Identity
IMEISV	International Mobile station Equipment Identity Software Version
IMPI	IP Multimedia Private Identity
IMPU	IP Multimedia PUBlic identity
IMSI	International Mobile Subscriber Identity
IP	Internet Protocol
IPv4	Internet Protocol Version 4
IPv6	Internet Protocol Version 6
IRI	Intercept Related Information
ISO	International Organization for Standardization
JPEG	Joint Photographic Experts Group
LD	Lawful Disclosure
LDID	Lawful Disclosure IDentifier
LEA	Law Enforcement Agency

LI	Lawful Intercept
LIID	Lawful Intercept IDentifier
MAC	Media Access Control
MIME	Multipurpose Internet Mail Extensions
MSISDN	Mobile Station International Subscriber Directory Number
NAI	Network Access Identifier
POSIX	Portable Operating System Interface
RFC	Request For Comments
SIP	Session Initiation Protocol
SV	Software Version
TC	Technical Committee
TCP	Transmission Control Protocol
TIFF	Tagged Image File Format
TLS	Transport Layer Security
UDP	User Datagram Protocol
URI	Uniform Resource Identifier
URL	Uniform Resource Locator
UTF	Unicode Transformation Format
UUID	Universally Unique Identifier
WI	Warrant Information
XML	eXtensible Markup Language
XSD	XML Schema Definition

4 Structure and model

4.1 Structure of the standard

The present document defines an interface and data structures that can be used to enable electronic warrant and tasking information to be exchanged. The processes for creating, approving and implementing a warrant are national matters. The present document does not attempt to dictate or define these processes, but provides an interface and data structures on which such processes can be built. Likewise, the present document assumes that a suitable physical network infrastructure is available. Figure 4.1 shows the conceptual structure of the standard.

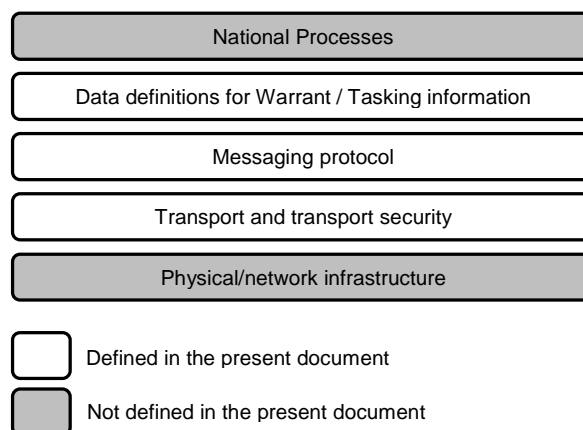

Figure 4.1: Conceptual structure of the standard

4.2 Structure of the present document

Clause 5 defines the how messages are exchanged in the messaging protocol.

Clause 6 defines the format of the messages exchanged in the messaging protocol.

Clause 7 describes the data definitions and structures for HI-1 Objects that are exchanged and used as part of the warrant and tasking processes.

Clause 8 describes the data definitions and structures for HI-1 Task Objects.

Clause 9 describes the transport mechanism(s) used by the messaging protocol.

4.3 Reference model

The present document defines an interface between two participants.

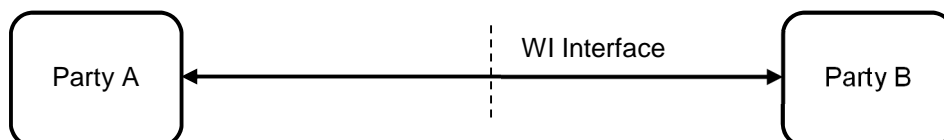

Figure 4.2: Reference model for WI interface

The process of approving or enacting a warrant will often involve more than two participants. Multi-party or multi-step interactions can, by national agreement, be composed of multiple two-party interactions. For example:

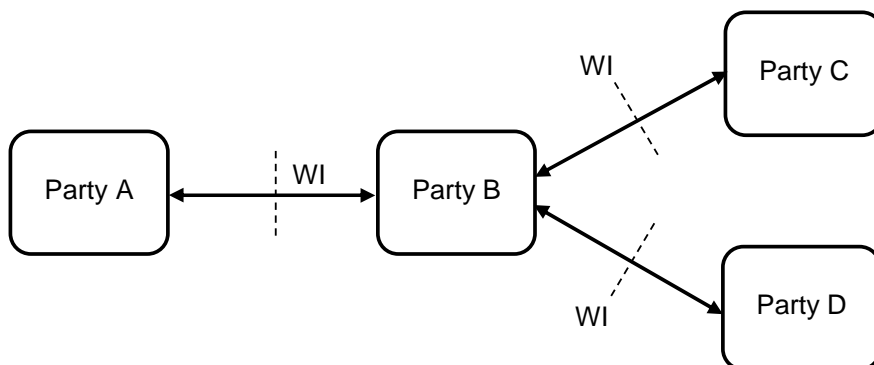

Figure 4.3: Example national process composed of WI interactions

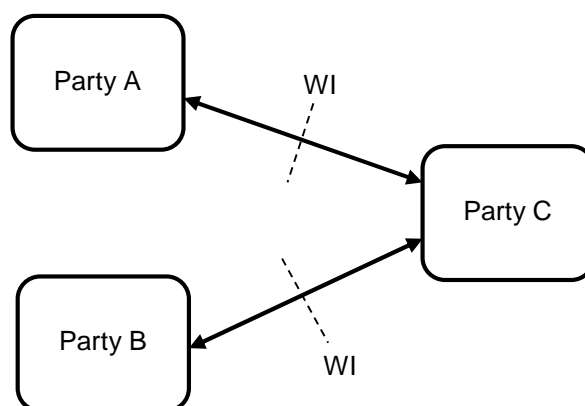

Figure 4.4: Further example national process composed of WI interactions

The nature of these "higher-level" multi-party processes will be dictated by national legislation, and as such are not defined in the present document.

5 Message Exchange

HI-1 defines two roles in an HI-1 communication:

- The Sender generates a Request Message, and transmits it.
- The Receiver receives the Request Message, processes it, and returns a Response Message to the Sender.

HI-1 message exchange therefore follows a simple Request-Response pattern between Sender and Receiver.

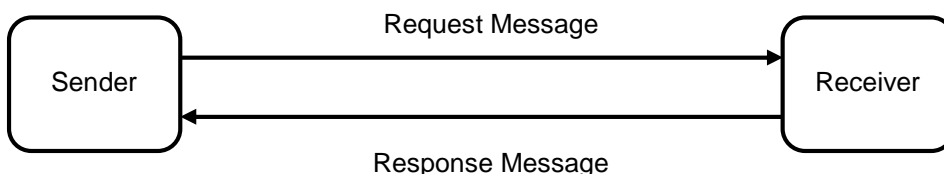

Figure 5.1

Note that the roles of Sender and Receiver are logical ones. A given node may act as both a Sender and Receiver for different exchanges, depending on the specifics of the relevant national processes, network configuration and implementation details.

Clause 6 describes the structure of Request and Response messages.

6 Message Structure

6.1 Overview

The high-level structure for HI-1 Request and Response messages is shown in figure 6.1.

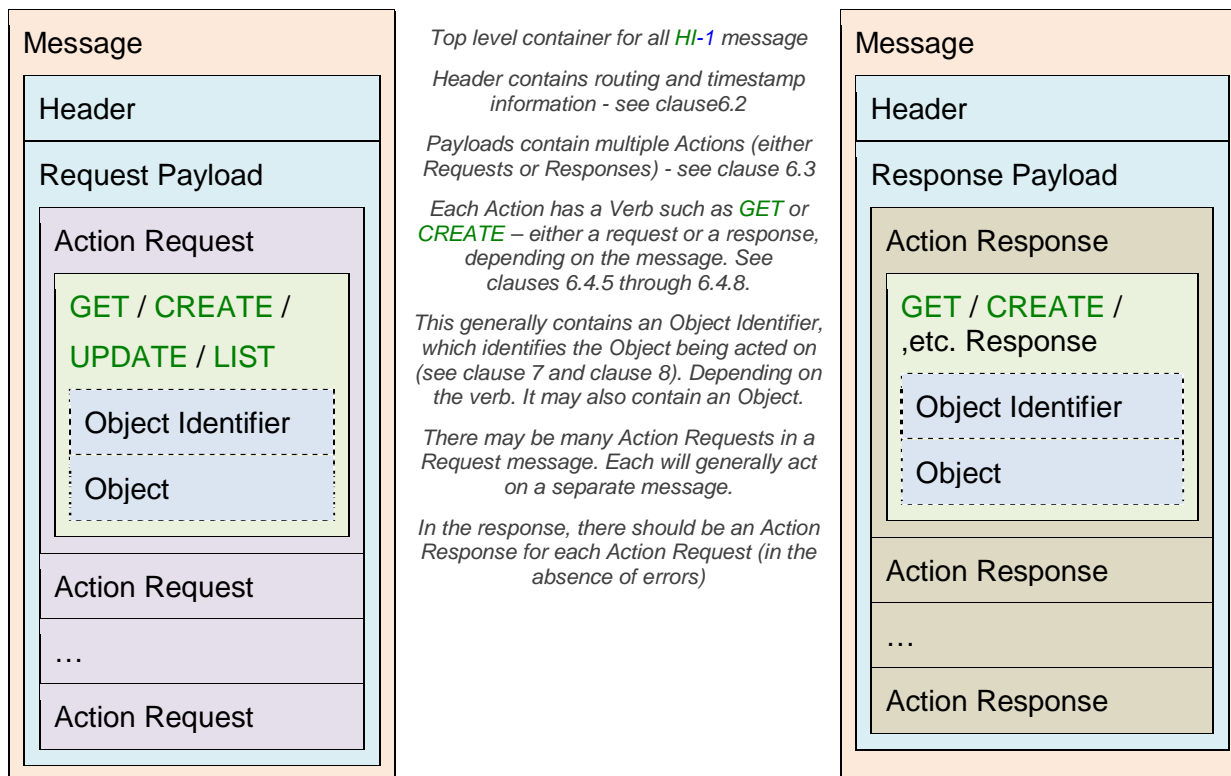

Figure 6.1: High-level message structure

Each message consists of two parts:

- Message Header.
- Message Payload (either a Request Payload or a Response Payload).

6.2 Message Header

6.2.1 Introduction

Every HI-1 Message shall contain a Message Header structure that is the same for all messages and contains basic routing and identification information.

If a Receiver receives a message containing a Header that does not follow the format and rules given in this clause, the Receiver shall reject the entire message with a top-level Action Unsuccessful response (see clause 6.4.9).

If a Sender receives a message containing a Header that does not follow the format and rules given above, the Sender shall disregard the message. Implementers are encouraged to alert the local user.

6.2.2 Structure

Table 6.1 shows the structure of every valid Message Header within an HI-1 message.

Table 6.1: High-level message structure

Field	Format	Description
SenderIdIdentifier	EndpointID (see clause 6.2.4 for details)	Nationally unique identifier and country code, sufficient to uniquely identify the Sender node in the message exchange. See clause 6.2.4 for details.
ReceiverIdentifier	EndpointID (see clause 6.2.4 for details)	Nationally unique identifier and country code, sufficient to uniquely identify the intended Receiver in the message exchange. See clause 6.2.4 for details.
TransactionIdentifier	UUID (see ETSI TS 103 280 [7]) in IETF RFC 4122 [3] canonical form	Identifier that uniquely identifies the message exchange between a given Sender and Receiver. See clause 6.2.5 for details.
Timestamp	QualifiedMicrosecondDateTime (see ETSI TS 103 280 [7])	Timestamp indicating the time the message was sent.
Version	Version (see clause 6.2.3 for details)	Version of the present document and relevant national profile used for interpreting the message.

6.2.3 Version

The Version structure indicates the version of the present document that should be used to interpret this message, as well as identifying the relevant national profile version that should be used.

Table 6.2: Version

Field	Format	Description
ETSIVersion	ShortString of the form "VX.Y.Z" (X gives major version, Y gives minor version, Z gives revision)	Version of the present document that should be used to interpret this message.
NationalProfileOwner	National profile owner (see clause F.3.2 for a definition of owners)	Identifies the owner of the relevant national profile. See clause F.3.2 for further details.
NationalProfileVersion	ShortString (see ETSI TS 103 280 [7])	Version of the national profile that should be used to interpret this message. National profile shall define the valid format and values for this field.

The present document does not specify any requirements for interoperability between systems using different versions of the present document or a national profile. The required behaviour of systems under such circumstances is a matter for national agreement.

6.2.4 EndpointID

An EndpointID provides the ability to provide a nationally unique identifier for a Sender or Receiver.

Table 6.3: Endpoint ID

Field	Format	Description
CountryCode	ISOCountryCode (see ETSI TS 103 280 [7]) giving 3166-1 alpha-2 code	Two-letter country code for the country. The reserved Country Code XX shall be used for international organizations.
UniqueIdentifier	LongString (see ETSI TS 103 280 [7])	Unique identifier sufficient for identifying the object/field within the country.

Sender and Receiver Identifiers are used within a Message Header to uniquely identify Sender and Receiver entities. As such, they have to be unique within the country specified by their respective country codes.

The Receiver shall populate the Receiver Identifier in all Response messages with its assigned Receiver Identifier. The Receiver shall also populate the Sender Identifier with the value specified in the original Request message, unless the Receiver is responding with a top level Action Unsuccessful payload and is unable to determine the original Sender Identifier. This means, for example, that a Receiver sending back a Response message still sets the Sender Identifier to the identifier of the original Sender, and the Receiver Identifier to its own identifier. If a Receiver cannot determine the original Sender Identifier, then the Receiver shall populate the Sender Identifier with the reserved value "UNKNOWN" (all capitals). This value may not be used as a valid Sender or Receiver Identifier.

If a Receiver receives a message with a valid but unexpected Receiver Identifier, the Receiver shall reject the entire message with a top-level Error Response.

If a Receiver cannot determine the original Sender Identifier Country Code, then the Receiver shall populate the Sender Identifier Country Code with the reserved value "ZZ" (all capitals) in the Response. This value may not be used as a value Sender or Receiver country code.

The precise format of Sender and Receiver Identifiers is for national agreement.

6.2.5 Transaction Identifiers

The Transaction Identifier is a UUID in IETF RFC 4122 [3] canonical form used within a Message Header that uniquely identifies a particular HI-1 message exchange between a particular Sender and Receiver. As such, the Transaction Identifier is unique for a pair of Request and Response messages.

Senders are responsible for creating Transaction Identifiers and maintaining their uniqueness between that Sender and a given Receiver. A Receiver that receives a duplicate Transaction Identifier from a given Sender may respond with a top-level Action Error if such duplication causes a system error, but is otherwise not required to check the uniqueness of the Transaction Identifier.

A Receiver creating a Response message shall populate the Transaction Identifier as specified in the original Request message, unless the Receiver is responding with a DELIVER Response (see clause 6.4.10) or Error payload or is unable to determine the original Sender, Receiver and Transaction Identifiers (e.g. the Request message is corrupted and unreadable). If a Receiver cannot determine the original Transaction Identifier, then the Receiver shall assign the Response message a new unique Transaction Identifier.

6.3 Message Payload

6.3.1 Introduction

Every HI-1 Message shall contain a Message Payload structure. A Request Message shall contain a Request Payload, while a Response message shall contain a Response payload. For a definition of Request and Response messages, see clause 5.

6.3.2 Request Payload

A Request Payload contains the information sent from a Sender to Receiver. It consists of a collection of Action Requests (see clause 6.4.2).

To improve processing efficiency and responsiveness, it is recommended that Action Requests in a Request Payload be limited to a single related set of objects, e.g. an Authorisation Object and its dependent Task Objects.

To ensure error-free and predictable processing of Task Objects, it is recommended that Action Requests concerning Authorisation Objects be placed ahead of its associated Action Requests concerning Task Objects. The easiest way to ensure that this takes place is to put all Action Requests concerning Authorisation Objects before any Action Requests concerning Tasking Objects in the Request Payload.

It is also recommended that Action Requests concerning Warrant documentation referenced within a Document Object be submitted prior to Action Requests concerning Authorisation Objects which reference that documentation.

6.3.3 Response Payload

A Response Payload contains information sent back from a Receiver to a Sender, in response to a Request Message.

The result of processing multiple Action Requests in a given Request message shall be as if they were processed in order of Action Identifier (see clause 6.4.4).

On receiving an Action Unsuccessful response, the Sender shall consider that particular Action Request as not having been understood or acted on. On receiving a top-level Action Unsuccessful structure, the Sender shall consider none of the original Request Message to have been understood or acted on. See clause 6.4.9 for more details.

6.4 Action Request and Responses

6.4.1 Overview

Clause 6.4 defines a set of verbs to aid the two parties in creating, updating, exchanging and reporting on the HI-1 Objects. It does not dictate business processes that vary nationally.

6.4.2 Action Requests

Each Action Request in the Request Payload shall be assigned an Action Identifier (see clause 6.4.4). Each Action Request appears in ascending order of the Action Identifier.

An Action Request shall be one of the following "verbs".

Table 6.4: Action Request types

Verb	Description	Definition
GET	Retrieve HI-1 Object	See clause 6.4.5
CREATE	Create new HI-1 Object	See clause 6.4.6
UPDATE	Update existing HI-1 Object	See clause 6.4.7
LIST	List identifiers of HI-1 Objects	See clause 6.4.8

The list of verbs is deliberately limited, as they are not intended to describe the business processes. Such higher level processes should instead be represented by the state of the relevant HI-1 Object. The present document simply provides a mechanism for transferring objects between participants in the process.

6.4.3 Action Responses

A response message sent from a Receiver to a Sender describes the legibility of the Request message received. An Action Response is generated for each Action Request provided in a Request, providing the Request Message as a whole could be understood. Each Action Response contains an Action Identifier that correlates with the Action Identifier provided in the Request; an exception to this requirement exists when the DELIVER verb is used. The DELIVER verb is used to deliver information as a result of and in response to a Task that was previously created. As there may be time between the creation of the Task and the DELIVER Response, it is not required for this Response to match the ActionIdentifier. In this scenario, the ActionIdentifier is determined by the Receiver.

An Action Response shall be one of the following "verbs".

Table 6.5: Action Response types

Verb	Description	Definition
GET RESPONSE	Successful retrieval of HI-1 Object of given identifier in Action Request.	See clause 6.4.5
CREATE RESPONSE	Receipt of legible Create Request of given identifier in Action Request.	See clause 6.4.6
UPDATE RESPONSE	Receipt of legible Update Request of given identifier in Action Request.	See clause 6.4.7
LIST RESPONSE	Successful retrieval of identifiers of given type from Action Request.	See clause 6.4.8
ERROR INFORMATION	Action Request could not be successfully processed. On receipt of this, the Sender shall regard the Action Request as not having been processed.	See clause 6.4.9
DELIVER RESPONSE	After processing the creation of an LDTaskObject (see clause 8.3), the Receiver may disclose the requested information via one or more DeliveryObject(s) (see clause 10).	See clause 6.4.10

6.4.4 Action Identifiers

Action Identifiers are used in Message Payloads, within Action Requests and Action Responses. The Action Identifier correlates an Action Request and Action Response between a given Sender and Receiver. Action Identifiers are generated by the Sender. The Action Identifier shall be a zero-based integer counter that is unique for each Action Request and corresponding Action Response for a given Transaction Identifier. The Sender shall populate the Request Payload with Action Requests in ascending order of Action Identifier. On receiving a Request Message, the Receiver shall check that the Action Identifiers are correctly in sequence, starting at zero and increasing by one for each Action Identifier. If the Action Identifiers are not correctly in sequence, the Receiver shall reject the Request Message with a top-level Error. Systems with a manual step should take particular care here to check for duplicates before performing any actions.

6.4.5 GET

A GET Request represents a request for the Receiver to return a particular HI-1 Object.

A GET Request shall have the following parameters.

Table 6.6: GET Request fields

Field	Format	Description	Mandatory?
Identifier	ObjectIdentifier (see clause 7.1.2)	Uniquely identifies the HI-1 Object that the Sender wishes to retrieve.	Yes

The Receiver shall respond to a successful GET Request with a GET Response with the following parameters.

Table 6.7: GET Response fields

Field	Format	Description	Mandatory?
HI1Object	HI-1 Object	Object that is identified by the identifier.	Yes

If the Receiver is unable to retrieve an Object with the defined ObjectIdentifier, then an Action Error response with an appropriate error code is returned.

6.4.6 CREATE

A CREATE Request represents a request for the Receiver to create a new HI-1 Object.

A CREATE Request shall have the following parameters.

Table 6.8: CREATE Request fields

Field	Format	Description	Mandatory?
HI1Object	HI-1 Object	Representation of the HI-1 Object to be created by the Receiver.	Yes

The Receiver shall respond to a successful CREATE Request with a CREATE Response with the following parameters.

Table 6.9: CREATE Response fields

Field	Format	Description	Mandatory?
Identifier	Object Identifier (see clause 7.1.2)	Value provided in the CREATE Request.	Yes
HI1Object	HI-1 Object	HI-1 Object that is identified by the identifier.	No

If the Receiver is unable to create an HI-1 Object with the defined identifier, then an Action Error response with an appropriate error code is returned. Unsuccessful creations could be as a result of an already used identifier.

The Receiver may, optionally, return an updated version of the Object as part of the CREATE Response (see table 6.9). This may be useful in situations where the Receiver populates or updates additional fields as part of processing the CREATE request.

The Receiver shall set the Generation of a created Object to 1 (see clause 7.1.3).

6.4.7 UPDATE

An UPDATE Request represents a request for the Receiver to update values in an existing HI-1 Object.

An UPDATE Request shall have the following parameters.

Table 6.10: UPDATE Request fields

Field	Format	Description	Mandatory?
HI1Object	HI-1 Object	Representation of the HI-1 Object to be updated by the Receiver.	Yes

The Receiver shall respond to a successful UPDATE Request with an UPDATE Response with the following parameters.

Table 6.11: UPDATE Response fields

Field	Format	Description	Mandatory?
Identifier	Object Identifier (see clause 7.1.2)	Value provided in the UPDATE Request.	Yes
HI1Object	HI-1 Object	HI-1 Object that is identified by the identifier.	No

If the Receiver is unable to update an Object with the defined identifier, then an Action Error response is returned. Unsuccessful updates could be as a result of using an identifier that does not exist.

Receivers shall observe the following on performing an UPDATE Request:

- If a single-valued field is present in the UPDATE Request Object, the Receiver should set the value of the equivalent field to match.
- If a list-field is present in the UPDATE Request Object, the Receiver should set the contents of the equivalent list field to match, i.e. overwrite the entire list and not append to it.
- If a field is absent in the UPDATE Request Object, the Receiver should leave the value of the equivalent field unchanged.

If the request can be understood and parsed, but cannot be acted upon, then the Receiver shall return an Error Information as described in clause 6.4.9.

The Receiver shall update the Generation of an Object that has been updated (see clause 7.1.3).

6.4.8 LIST

A LIST Request represents a request for the Receiver to list records of HI-1 object identifiers that the Sender is permitted to have knowledge of, optionally depending on the type requested. Although no business processes are defined in the present document, the Receiver is responsible for listing only the identifiers that a Sender is allowed to access. Details of how to determine this shall be specified in the relevant national profile.

This method shall only be allowed if explicitly required by the relevant national profile. Use of the capability on a national basis should be carefully considered for its security implications. If the Receiver does not allow the use of the LIST verb, then it shall respond to a LIST Request with an Action Error response.

The list of objects provided in a response message may be limited subject to national agreement, for example to only Active objects, or to a configured number of most recent objects. This is needed to prevent potentially many years worth of data being dumped on the requestor in a message too large for the requestor system to handle. Such details shall be specified in the relevant national profile.

A LIST Request shall have the following parameters.

Table 6.12: LIST Request fields

Field	Format	Description	Mandatory?
ObjectType	ObjectType dictionary entry (see below)	Specifies the type of identifiers to be listed.	No
LastChanged	QualifiedDateTime (see ETSI TS 103 280 [7])	If specified, the Receiver shall return only records of Objects whose LastChanged field is equal to or later than the value specified.	No

The Receiver shall respond to a successful LIST Request with a list of LIST Response records, one for each HI-1 Object matching the request constraints (e.g. ObjectType). Each LIST Response record shall have the following parameters.

Table 6.13: LIST ResponseRecord fields

Field	Format	Description	Mandatory?
ObjectType	ObjectType dictionary entry (see below)	Value provided in the LIST Request.	Yes
Identifier	HI-1 ObjectIdentifier (see clause 7.1.2)	Identifier of the Object.	Yes
CountryCode	ISOCountryCode (see ETSI TS 103 280 [7]) giving ISO 3166-1 Alpha-2 code [14]	See clause 7.1.1.	No
OwnerIdentifier	ShortString (see ETSI TS 103 280 [7])	See clause 7.1.1.	No
Generation	Positive integer	See clause 7.1.3.	Yes
ExternalIdentifier	LongString (see ETSI TS 103 280 [7])	See clause 7.1.1.	No
LastChanged	QualifiedDateTime (see ETSI TS 103 280 [7])	Indicates the last time an Object was altered, either via HI-1 or locally.	No

The ObjectType dictionary is defined as follows (see annex G for more details on Dictionaries).

Table 6.14: ObjectType Dictionary

Dictionary Owner	Dictionary Name
ETSI	ObjectType
Defined DictionaryEntries	
Value	Meaning
Authorisation	An Authorisation Object as defined in clause 7.2
Document	A Document Object as defined in clause 7.3
Notification	A Notification Object as defined in clause 7.4
Task	A Task Object as defined in clause 8.2

If the Receiver contains no Objects of the defined type, then an empty list is returned.

If the Request can be understood and parsed, but cannot be acted upon, then the Receiver shall return an Error Information as described in clause 6.4.9.

In the particular case that the ObjectType is set to "Notification", the Receiver shall only return the Object Identifiers of instances of a NotificationObject whose NewNotification flag is set (see clause 7.4.4 for more details). Implementations may need additional rules or logic to restrict the association of instances of a NotificationObject. Where needed, such logic shall be specified by the relevant national profile.

6.4.9 Action Unsuccessful Information

The Receiver shall respond to unsuccessful requests with an Action Unsuccessful Information structure with the following parameters.

Table 6.15: Action Unsuccessful Information fields

Field	Format	Description	Mandatory?
ErrorCode	Integer	Integer code specifying the type of error.	Yes
ErrorInformation	LongString (see ETSI TS 103 280 [7])	Detail of the error that occurred.	Yes

If the message received by the Receiver is understood and parsed, but an individual Action Request cannot be acted on, then the response shall contain an individual Action Unsuccessful Response. On receiving this Action Unsuccessful Response, a Sender shall consider the associated request to have not been acted on.

If the message received by the Receiver as a whole cannot be understood, then the response shall contain a top-level Action Unsuccessful structure explaining the nature of the error, instead of a collection of Action Responses. This shall only be used in error conditions which prevent any of the Action Requests being understood - for example, a fatal syntax error that makes the entire request message illegible. On receiving this top-level Action Unsuccessful Error structure, a Sender shall consider none of the original request to have been understood or acted on.

6.4.10 DELIVER

A DELIVER Response represents a mechanism to deliver information in response to a request. In the present document this is used in the scenario where a LEA creates an LDTaskObject and the CSP responds to it by sending one or more DeliveryObject(s) in response.

A DELIVER Response shall have the following parameters.

Table 6.16: DELIVER response fields

Field	Format	Description	Mandatory?
Identifier	ObjectIdentifier (see clause 7.1.2)	Uniquely identifies the Delivery Object that the Responder wishes to deliver.	Yes
HI1Object	HI-1 Object	Delivery Object that is identified by the identifier.	Yes

7 Data Definitions

7.1 HI-1 Object

7.1.1 Overview

HI-1 Objects represent the current state of a particular national process. The relevant national profile shall specify which fields are required for a particular HI-1 Object to be valid within the relevant national processes.

All HI-1 Objects have the following top-level structure.

Table 7.1: HI-1 Object top-level fields

Field	Format	Description
ObjectIdentifier	UUID (see ETSI TS 103 280 [7]) given in IETF RFC 4122 [3] canonical form	Uniquely identifies the Object (see clause 7.1.2).
CountryCode	ISOCountryCode (see ETSI TS 103 280 [7]) giving ISO 3166-1 Alpha-2 code [14]	Two-letter country code for the country. If the Owner Identifier identifies an international organization, the reserved Country Code XX.
OwnerIdentifier	ShortString (see ETSI TS 103 280 [7])	String to represent the agency/organization involved. Format for national agreement.
Generation	Positive integer	Indicates the generation or version of the Object (see clause 7.1.3).
ExternalIdentifier	LongString (see ETSI TS 103 280 [7])	Optional identifier for the Object, as assigned by the Receiver. For correlation with legacy or pre-HI-1 systems.
AssociatedObjects	List of ObjectIdentifiers (see clause 7.1.4)	Indicated other HI-1 Objects which are associated with a given Object.
LastChanged	QualifiedDateTime (see ETSI TS 103 280 [7])	Indicates the last time this Object was altered, either via HI-1 or locally.
NationalHandlingParameters	Defined by the relevant national profile	Nationally-defined information concerning the handling of the Object.

7.1.2 ObjectIdentifier

An ObjectIdentifier is an identifier that is used to uniquely identify and refer to a particular Object. To follow RESTful principles, an HI-1 Object should be identified by a persistent identifier to refer to or locate the Object. This identifier is essential to the automated handling and management of the lifecycle of the object, and is therefore not permitted to change for the lifetime of the Object as it is used to uniquely identify the HI-1 Object.

7.1.3 Generation

The Generation parameter indicates how many times the Object has been changed or updated.

The Receiver shall set the Generation of an Object to 1 when it is created. A Sender shall not specify the Generation as part of a CREATE Request, and a Receiver shall return an Action Unsuccessful Information response if it attempts to.

The Receiver shall increment the Generation of an Object by 1 each time it is altered or updated, either via HI-1 or by other means. A Sender may optionally specify the Generation as part of an UPDATE Request. In this case, the Receiver shall check whether the Generation matches the current Generation of the Object. If so, the Receiver shall process the UPDATE Request normally, and then increment the Generation. If not, the Receiver shall respond with an Action Unsuccessful Information response. If the Sender omits the Generation as part of the UPDATE Request, then the Receiver shall process the UPDATE normally and increment the Generation.

7.1.4 AssociatedObjects

The Associated Objects field gives a list of other Objects which are related or associated in some way with this Object. Examples include Task Objects associated with an Authorisation, or Document Objects associated with an Authorisation or Task Object.

Table 7.2: AssociatedObjects

Field	Format	Description
AssociatedObjects	List of ObjectIdentifiers	List of other Objects which are related or associated with the current Object.

7.1.5 LastChanged

The LastChanged field indicates the date and time that the HI-1 Object was last changed, either as a result of an HI-1 Action, or as the result of local activity at the Receiver (e.g. local operator intervention, or a change of workflow state).

This field shall be set by the Receiver when an Object is first created, and each time it is modified as a result of either an HI-1 Action or local activity.

Only the Receiver may change the content of the LastChanged field. A Receiver shall reject an Action which attempts to modify or set the LastChanged field.

7.1.6 NationalHandlingParameters

The NationalHandlingParameters structure is provided to allow the relevant national profile to specify nationally-specific handling information (e.g. routing information or security labelling).

The format and use of the NationalHandlingParameters structure shall be defined in the relevant national profile.

7.2 Authorisation Object

7.2.1 Overview

An Authorisation Object represents the state of an authorisation - that is, a legal instrument by which legal action is permitted. It has the following fields (following the categories defined in ETSI TR 103 690 [i.1]).

Table 7.3: Authorisation Object

Field	Format	Description	Reference
AuthorisationReference	LongString (see ETSI TS 103 280 [7]).	Nationally defined reference for the Authorisation. This is provided to allow correlation with non-HI1 processes.	Clause 7.2.2
AuthorisationLegalType	AuthorisationLegalType DictionaryEntry.	Indicates the type and legal basis under which the Authorisation is sought e.g. a reference to the relevant legal code or statutory purpose. The format and acceptable values for this field shall be defined by the relevant national profile.	Clause 7.2.3
AuthorisationPriority	AuthorisationPriority DictionaryEntry.	Usage for national agreement When used, a default dictionary is provided in clause 7.2.4.	Clause 7.2.4
AuthorisationStatus	AuthorisationStatus DictionaryEntry.	The current status of the Authorisation according to the Receiver.	Clause 7.2.5
AuthorisationDesiredStatus	AuthorisationDesiredStatus DictionaryEntry.	The desired status of the Authorisation, as specified by the Sender.	Clause 7.2.6
AuthorisationTimespan	AuthorisationTimespan (see clause 7.2.7).	The period of validity for the Authorisation.	Clause 7.2.7
AuthorisationCSPID	List of EndpointIDs (see clause 6.2.3).	Identifies the CSP(s) required to implement the Authorisation.	Clause 7.2.8
AuthorisationCreationTimestamp	QualifiedDateTime (see ETSI TS 103 280 [7]).	Indicates when the Authorisation was created.	Clause 7.2.9
AuthorisationServedTimestamp	QualifiedDateTime (see ETSI TS 103 280 [7]).	Indicates when the Authorisation was served on the CSP.	Clause 7.2.10
AuthorisationTerminationTimestamp	QualifiedDateTime (see ETSI TS 103 280 [7]).	Indicates when an Authorisation was terminated, in the event that it is explicitly terminated prior to the end of its validity.	
AuthorisationApprovalDetails	ApprovalDetails (see annex F).	Gives details of who approved or signed the Authorisation, and when.	Clause 7.2.11
AuthorisationInvalidReason	ActionUnsuccessful structure (see clause 6.4.9).	Optional information for the Receiver to indicate why the Object is in the Invalid state. Usage for national agreement.	Clause 6.4.9
AuthorisationFlags	AuthorisationFlags (see clause 7.2.12).	Set of flags associated with the Authorisation Object.	Clause 7.2.12
AuthorisationManualInformation	LongString (see ETSI TS 103 280 [7]).	Any additional human-readable information regarding the Authorisation.	
NationalAuthorisationParameters	See annex G.	See annex G.	Annex G

7.2.2 AuthorisationReference

The AuthorisationReference field provides a nationally defined reference for the Authorisation. This is provided to allow correlation with non-HI1 processes. The format and permissible values for the AuthorisationReference field shall be defined by the relevant national profile.

7.2.3 AuthorisationLegalType

The AuthorisationLegalType field indicates the type and legal basis for the Authorisation. Examples include references to the relevant legal code or statutory purpose.

Given as an AuthorisationLegalType DictionaryEntry. The valid set of values for this field is likely to be closely coupled to national legislation. It is therefore expected that most national profiles will need to define their own extensions to this dictionary.

Table 7.4: AuthorisationPriority Dictionary

Dictionary Owner	Dictionary Name
ETSI	AuthorisationLegalType
Defined DictionaryEntries	
Value	Meaning
Manual	The implementation should consult the AuthorisationManualInformation field for details on the type of legal Authorisation

7.2.4 AuthorisationPriority

The AuthorisationPriority field gives an indication of the priority of the authorisation. Usage is for national agreement. The meaning of a given priority shall be specified by the national profile. The AuthorisationPriority, if used, shall be given as an AuthorisationPriority DictionaryEntry. The AuthorisationPriority Dictionary is defined in table 7.5 (see annex F for more details on Dictionaries).

Table 7.5: AuthorisationPriority Dictionary

Dictionary Owner	Dictionary Name
ETSI	AuthorisationPriority.
Defined DictionaryEntries	
Value	Meaning
High	The Authorisation has a high priority.
Routine	The Authorisation has a routine priority.

7.2.5 AuthorisationStatus

The AuthorisationStatus field indicates the current status of the authorisation as determined by the Receiver. A Sender shall not attempt to set the AuthorisationStatus as part of a CREATE or UPDATE Request, and a Receiver shall return an Action Unsuccessful Information response if it attempts to.

The Status field provides a key mechanism for mapping the content of the Object to the relevant nationally-defined processes. The rules for evaluating the correct value of the Status field shall be defined in the relevant national profile.

Given as an AuthorisationStatus Dictionary Entry. The AuthorisationStatus Dictionary is defined in table 7.6 (see annex F for more details on Dictionaries).

Table 7.6: AuthorisationStatus Dictionary

Dictionary Owner	Dictionary Name
ETSI	AuthorisationStatus.
Defined DictionaryEntries	
Value	Meaning
AwaitingApproval	The Authorisation is still waiting approval from one or more relevant authorities.
EmergencyApproval	The Authorisation has been approved under emergency procedures.
Approved	The Authorisation has been approved by the relevant authorities.
Rejected	The Authorisation has been explicitly denied or rejected by one or more relevant authorities.
Suspended	The Authorisation has been suspended temporarily.
Cancelled	The Authorisation has been permanently cancelled.
Expired	The expiry date for this Authorisation has passed, meaning that the Authorisation has lapsed.
Invalid	The Authorisation is not active due to a problem with the current information populated in the Authorisation Object.

7.2.6 AuthorisationDesiredStatus

The AuthorisationDesiredStatus field indicates the current status of the authorisation as determined by the Sender. Given as an AuthorisationDesiredStatus Dictionary Entry. The AuthorisationDesiredStatus Dictionary is defined in table 7.7 (see annex F for more details on Dictionaries).

Table 7.7: AuthorisationDesiredStatus Dictionary

Dictionary Owner	Dictionary Name
ETSI	AuthorisationDesiredStatus.
Defined Dictionary Entries	
Value	Meaning
AwaitingApproval	The Authorisation is still waiting approval from one or more relevant authorities.
EmergencyApproval	The Authorisation has been approved under emergency procedures.
Approved	The Authorisation has been approved by the relevant authorities.
Rejected	The Authorisation has been explicitly denied or rejected by one or more relevant authorities.
Suspended	The Authorisation has been suspended temporarily.
Cancelled	The Authorisation has been permanently cancelled.
Expired	The expiry date for this Authorisation has passed, meaning that the Authorisation has lapsed.

7.2.7 AuthorisationTimespan

The AuthorisationTimespan field gives the period of time for which the authorisation is valid. This may not necessarily be the time that the legal action is active. The timestamps shall include a time-zone specifier.

Table 7.8: AuthorisationTimespan

Field	Format	Description
StartTime	QualifiedDateTime (see ETSI TS 103 280 [7])	Start time for the authorisation.
EndTime	QualifiedDateTime (see ETSI TS 103 280 [7])	End time for the authorisation.

7.2.8 AuthorisationCSPID

The AuthorisationCSPID field gives a list of globally unique CSP Identifiers that identify the CSPs required to implement the authorisation.

In some jurisdictions, authorisations may be required to be specific to an identified CSP. In those cases, this field may become a required field for Authorisation Objects to be valid and may be restricted from changing during the authorisation lifecycle. Also, validation checks may determine if the CSP exists, and searches associated with a CSP may be possible.

7.2.9 AuthorisationCreationTimestamp

The AuthorisationCreationTimestamp field indicates the time that the authorisation was created. The timestamp shall include a time-zone specifier. If necessary, the precise meaning of this field should be clarified by the relevant national profile.

7.2.10 AuthorisationServedTimestamp

The AuthorisationServedTimestamp indicates the time that the authorisation was served on the CSP. The timestamp shall include a timezone specifier.

7.2.11 AuthorisationApprovalDetails

The AuthorisationApprovalDetails field provides details of who approved the Authorisation.

See annex E for further details.

7.2.12 AuthorisationFlags

The AuthorisationFlags field allows a set of multiple flags to be associated with the Authorisation Object. Each flag is given as an AuthorisationFlag Dictionary Entry. If a flag is present in the Flags field, then the meaning given as part of that flag's definition shall be taken to apply.

The AuthorisationFlag Dictionary is defined in table 7.9 (see annex F for more details on Dictionaries).

Table 7.9: AuthorisationFlag Dictionary

Dictionary Owner	Dictionary Name
ETSI	AuthorisationFlag.
Defined DictionaryEntries	
Value	Meaning
IsEmergency	Indicates if the authorisation was issued under nationally-defined emergency procedures (e.g. orally). The circumstances and consequences for setting the field shall be defined by the relevant national profile.
IsConsensual	Indicates that the current authorisation is for consensual interception. This may alter the process or documentation accompanying the authorisation.
IsTest	Indicates that the current authorisation is given for test purposes. This may alter the process or documentation accompanying the authorisation.

7.3 Document Object

7.3.1 Overview

A Document Object represents a particular legal document or instrument related to a given Authorisation or Task. Examples may include the original warrant documentation, or subsequent modification or renewal documents.

The Document Object has the following fields.

Table 7.10: Document Object

Field	Format	Description	Reference
DocumentReference	LongString (see ETSI TS 103 280 [7]).	Nationally-defined reference for the Document. This is provided to allow correlation with non-electronic processes.	Clause 7.3.2
DocumentName	LongString (see ETSI TS 103 280 [7]).	Name for a specific document.	Clause 7.3.3
DocumentStatus	DocumentStatus Dictionary Entry.	The current status of the Document as determined by the Receiver.	Clause 7.3.4
DocumentDesiredStatus	DesiredDocumentStatus Dictionary Entry.	The current status of the Document as specified by the Sender.	Clause 7.3.5
DocumentTimespan	TimeSpan.	Optional start and end datetimes indicating the period of validity of the Document.	Clause 7.3.6
DocumentType	Document Type.	Indicates the type of document that this Object represents. The list of permissible Document Types is defined by national agreement.	Clause 7.3.7
DocumentProperties	Document Properties.	A list of key-value pairs that define additional properties of the Document in a machine-readable manner. Permissible document properties for each Document Type are defined by national agreement.	Clause 7.3.8
DocumentBody	Complex type.	Contains an electronic copy of the original document e.g. a scanned image.	Clause 7.3.9
DocumentSignature	ApprovalDetails (see annex F).	Details of the approval given for the present document, including any necessary signature information.	Clause 7.3.10

Field	Format	Description	Reference
DocumentInvalidReason	ActionUnsuccessful structure (see clause 6.4.9).	Optional information for the Receiver to indicate why the Document Object is in the Invalid state. Usage for national agreement.	Clause 6.4.9
NationalDocumentParameters	See annex G.	See annex G.	Annex G

7.3.2 DocumentReference

The DocumentReference field gives a nationally-defined reference for the Document. This is provided to allow correlation with non-electronic processes.

7.3.3 DocumentName

The DocumentName field allows a nationally defined name for the Document to be specified. The permissible values and format of this field shall be specified by the relevant national profile.

7.3.4 DocumentStatus

The DocumentStatus field gives the status of the Document as determined by the Receiver. A Sender shall not attempt to set the DocumentStatus as part of a CREATE or UPDATE Request, and a Receiver shall return an Action Unsuccessful Information response if the Sender attempts to do so.

The Status field provides a key mechanism for mapping the content of the Object to the relevant nationally-defined processes. The rules for evaluating the correct value of the Status field shall be defined in the relevant national profile.

Given as a DocumentStatus Dictionary Entry. The DocumentStatus Dictionary is defined in table 7.11 (see annex F for more details on Dictionaries).

Table 7.11: DocumentStatus Dictionary

Dictionary Owner	Dictionary Name
ETSI	DocumentStatus.
Defined DictionaryEntries	
Value	Meaning
AwaitingApproval	The Document is still waiting approval from one or more relevant authorities.
Approved	The Document has been approved by the relevant authorities.
Rejected	The Document has been explicitly denied or rejected by one or more relevant authorities.
Suspended	The Document has been suspended temporarily.
Cancelled	The Document has been permanently cancelled.
Expired	The expiry date for this Document has passed.
Invalid	The Document is invalid due to a problem with the current information populated in the Document Object.

7.3.5 DocumentDesiredStatus

The DocumentDesiredStatus field gives the status of the Document as specified by the Sender.

Given as a DocumentDesiredStatus Dictionary Entry. The DocumentDesiredStatus Dictionary is defined in table 7.12 (see annex F for more details on Dictionaries).

Table 7.12: DocumentDesiredStatus Dictionary

Dictionary Owner	Dictionary Name
ETSI	DocumentDesiredStatus.
Defined DictionaryEntries	
Value	Meaning
AwaitingApproval	The Document is still waiting approval from one or more relevant authorities.
Approved	The Document has been approved by the relevant authorities.
Rejected	The Document has been explicitly denied or rejected by one or more relevant authorities.
Suspended	The Document has been suspended temporarily.
Cancelled	The Document has been permanently cancelled.
Expired	The expiry date for this Document has passed.

7.3.6 DocumentTimespan

The DocumentTimespan field gives the period of time for which the Document is valid. The precise meaning may depend on the type of document being represented. The timestamps shall include a timezone specifier.

Table 7.13: DocumentTimespan

Field	Format	Description
StartTime	QualifiedDateTime (see ETSI TS 103 280 [7]).	Start time for the document.
EndTime	QualifiedDateTime (see ETSI TS 103 280 [7]).	End time for the document.

7.3.7 DocumentType

Indicates the type of document that this Document Object represents. Given as a DocumentType DictionaryEntry. The DocumentType Dictionary is defined below (see annex F for more details on Dictionaries). Since each jurisdiction is likely to have its own particular set of documents, it is expected that most national profiles will need to extend this dictionary.

Table 7.14: DocumentType Dictionary

Dictionary Owner	Dictionary Name
ETSI	DocumentType.
Defined DictionaryEntries	
Value	Meaning
Warrant	This Document represents a legal warrant.

7.3.8 DocumentProperties

A list of key-value pairs that define additional properties of the Document in a machine-readable manner. Permissible property types shall be specified in a dictionary defined by the relevant national profile.

Table 7.15: DocumentProperties

Field	Format	Description
PropertyType	Dictionary entry (see below).	Type of the property. The dictionary of permissible document properties shall be defined by the relevant national profile.
PropertyValue	LongString (see ETSI TS 103 280 [7]).	Value of the property.

7.3.9 DocumentBody

Binary representation of the original paper documentation (e.g. TIFF or JPEG).

Table 7.16: DocumentBody

Field	Format	Description
Contents	Binary data, represented using XSD's base64Binary type.	Binary representation of the original paper authorisation documentation.
Content Type	ShortString containing a MIME type as per IETF RFC 2045 [9] and IETF RFC 2046 [10]. The details of permissible MIME types shall be defined by the relevant national profile.	Encoding of the binary Contents file (e.g. "image/jpeg").
Checksum	UTF-8 string containing an MD5 checksum of the binary data, given as hexadecimal digits, as per IETF RFC 1321 [11].	Checksum to ensure that the Contents field has been transmitted correctly.

7.3.10 DocumentSignature

The DocumentSignature field gives approval details for the Document represented by the Document Object. This may include signature information.

The DocumentSignature field is specified using the ApprovalDetails structure. See annex E for more details.

7.4 Notification Object

7.4.1 Overview

The Notification Object is a means for a Receiver to notify a Sender of any change or update to an Object or set of Objects that was not due to a direct HI-1 Action from the Sender. Such changes may occur for a number of reasons, for example local user interaction at the Receiver.

The use of Notification Objects are subject to national agreement.

When a Receiver wishes to notify a Sender of changes to an Object or set of Objects, it may create a Notification Object associated to that Object via the Associated Objects field. A Notification Object may be associated to more than one Object. Similarly, an Object may be associated to multiple Notification Objects as it may be subject to a number of changes over time.

Notification Objects may only be created by the Receiver. A Receiver that receives a CREATE Action attempting to create a Notification Object shall return an error.

The Notification Object consists of the following fields. Further details are given in the clause 7.4.2.

Table 7.17: Notification Object

Field	Format	Description	Reference
NotificationDetails	LongString (see ETSI TS 103 280 [7]).	Human readable information regarding the notification.	Clause 7.4.2
NotificationType	NotificationType Dictionary Entry (see clause 7.4.3).	Identifies the type of notification, for use in automating workflow processes. The format and acceptable values for this field shall be defined by the relevant national profile.	Clause 7.4.3
NewNotification	Boolean.	Indication that this is a new notification. See clause 7.4.4 for more details.	Clause 7.4.4
NotificationTimestamp	QualifiedDateTime (see ETSI TS 103 280 [7]).	Timestamp indicating the time of the Notification.	Clause 7.4.5
NationalNotificationParameters	See annex G.	See annex G.	Clause 7.4.6

7.4.2 NotificationDetails

The NotificationDetails field shall carry human-readable information regarding the nature of the notification (for example, a summary of any changes, or the reason for the notification).

A Receiver shall ignore any attempt by a Sender to UPDATE the value of the Notification details field.

7.4.3 NotificationType

The NotificationType field indicates the type of Notification being given. It is given as a NotificationType Dictionary Entry. The NotificationType Dictionary is defined in table 7.18 (see annex F for more details on Dictionaries). Since the list of notification types is tightly coupled to national processes and workflow, it is expected that each national profile will need to extend this dictionary.

Table 7.18: NotificationType Dictionary

Dictionary Owner	Dictionary Name
ETSI	NotificationType.
Defined DictionaryEntries	
Value	Meaning
General	A general notification that a change has occurred with the specified Objects.

7.4.4 NewNotification

The NewNotification flag is used to indicate whether the notification is new, and therefore whether it should be returned in a query for New Notifications (see clause 6.4.8).

When a Receiver creates a new Notification Object, the NewNotification flag shall be set to True. The NewNotification Flag may be set to False, thereby removing it from the Notification Objects returned by the Receiver when queried for new Notifications, in any of the following ways:

- Once a Sender is satisfied that it has been notified, it may UPDATE the NewNotification field to False explicitly.
- Once a Receiver is satisfied that the Sender has been notified (e.g. upon Receiving a GET or UPDATE for all Associated Objects) the Receiver may change the NewNotification field to False. The logic and circumstances under which the Receiver makes such a change shall be specified by the relevant national profile.

Archiving and persistence of Notification Objects once the NewNotification flag has been cleared is a matter for national agreement.

7.4.5 NotificationTimestamp

The NotificationTimestamp field shall be set by the Receiver to the time at which the notification event occurred.

The Receiver shall ignore any attempt by a Sender to UPDATE the value of the NotificationTimestamp field.

7.4.6 NationalNotificationParameters

The use and definition of the NationalNotificationParameters structure is for national agreement. See annex G.

8 Task Objects

8.1 Overview

This clause defines a set of HI-1 Object definitions that can be used to describe "Tasks". These Objects are intended to describe the technical details of a request or instruction, and will typically be associated with an Authorisation Object which represents the legal basis for the technical request.

The present document defines two type of Task Objects, the LITaskObject, which represents a technical request to perform Lawful Intercept and the LDTaskObject, which represents a technical request to perform Lawful Disclosure.

8.2 LITaskObject

8.2.1 Overview

An LITaskObject represents the state of an LI task - that is, the act of intercepting of a communication. This corresponds to the WarrantTargetID and WarrantTechSpec elements defined in ETSI TR 103 690 [i.1]. In general, multiple tasks may be authorised by a single warrant.

The LITaskObject consists of the following fields. Further details are given in clause 8.2.2.

Table 8.1: LITaskObject

Field	Format	Description	Reference
Reference	LIID (see ETSI TS 103 280 [7]).	LIID assigned to the product of task.	Clause 8.2.2
Status	TaskStatus Dictionary Entry.	The current status of the task as determined by the Receiver.	Clause 8.2.3
DesiredStatus	TaskDesiredStatus Dictionary Entry.	The current status of the task as specified by the Sender.	Clause 8.2.4
TimeSpan	Collection of QualifiedDateTimes (see ETSI TS 103 280 [7]).	Indicated the period of time for which task should occur, as well as provisioning and deprovisioning times.	Clause 8.2.5
TargetIdentifier	TargetIdentifier (see clause 8.2.6).	The communication address or technical identifier used to identify the target of task. Given as a list of TargetIdentifier types (see clause 7.3.6) which are combined (with ordering and Boolean ANDed together) to identify the target's traffic.	Clause 8.2.6
DeliveryType	DictionaryEntry (see clause 8.2.7).	Typically for interception indicates whether the interception should contain IRI, CC or both.	Clause 8.2.7
DeliveryDetails	List of DeliveryDestination structures (see clause 8.2.8).	Destination(s) for the intercepted LI traffic.	Clause 8.2.8
ApprovalDetails	ApprovalDetails (see annex F).	Details regarding the approval for this Task, including dates and signatures where appropriate.	Clause 8.2.9
CSPID	EndpointID (see clause 6.2.4).	Describes the CSP required to implement the Task.	Clause 8.2.10
HandlingProfile	DictionaryEntry (see clause 8.2.11).	A dictionary entry which gives the name of a handling profile that represents a set of configuration information associated with this task.	Clause 8.2.11
InvalidReason	ActionUnsuccessful structure (see clause 6.4.9).	Optional information for the Receiver to indicate why the Object is in the Invalid state. Usage for national agreement.	Clause 6.4.9

Field	Format	Description	Reference
Flags	TaskFlags (see clause 8.2.12).	A set of flags associated with the Task Object.	Clause 8.2.12
NationalLITaskingParameters	See annex G.	See annex G.	Annex G

8.2.2 Reference

The Reference field gives a reference identifier for the Task, for correlation with other processes. For LI, this shall be set to the LIID that will be assigned to the product of interception. Format will be as per ETSI TS 103 280 [7].

8.2.3 Status

The Status field gives the status of the LITaskObject as determined by the Receiver. A Sender shall not attempt to set the Status as part of a CREATE or UPDATE Request, and a Receiver shall return an Action Unsuccessful Information response if the Sender attempts to do so.

The Status field provides a key mechanism for mapping the content of the Object to the relevant nationally-defined processes. The rules for evaluating the correct value of the Status field shall be defined in the relevant national profile.

Given as a TaskStatus Dictionary Entry. The TaskStatus Dictionary is defined in table 8.2 (see annex G for more details on Dictionaries).

Table 8.2: TaskStatus Dictionary

Dictionary Owner	Dictionary Name
ETSI	TaskStatus.
Defined DictionaryEntries	
Value	Meaning
AwaitingApproval	The Task is still waiting approval from one or more relevant authorities.
AwaitingProvisioning	The Task is approved, but is not yet provisioned in the LI system.
Active	The Task is active and can produce LI traffic.
Rejected	The Task has been explicitly denied or rejected by one or more relevant authorities.
Suspended	The Task has been suspended temporarily.
Cancelled	The Task has been permanently cancelled.
Expired	The expiry date for this Task has passed, meaning that the Task has lapsed.
Error	The Task is not active due to a problem with the underlying LI system.
Invalid	The Task is not active due to a problem with the current information populated in the Task Object.

8.2.4 DesiredStatus

The DesiredStatus field gives the status of the LITaskObject as determined by the Sender.

Given as a TaskDesiredStatus Dictionary Entry. The TaskDesiredStatus Dictionary is defined in table 8.3 (see annex G for more details on Dictionaries).

Table 8.3: TaskDesiredStatus Dictionary

Dictionary Owner	Dictionary Name
ETSI	TaskDesiredStatus.
Defined DictionaryEntries	
Value	Meaning
AwaitingApproval	The Task is still waiting approval from one or more relevant authorities.
AwaitingProvisioning	The Task is approved, but is not yet provisioned in the LI system.
Active	The Task is active and can produce LI traffic.
Rejected	The Task has been explicitly denied or rejected by one or more relevant authorities.
Suspended	The Authorisation has been suspended temporarily.
Cancelled	The Authorisation has been permanently cancelled.
Expired	The expiry date for this Task has passed, meaning that the Task has lapsed.

8.2.5 TimeSpan

The period for which the interception is active. May not be identical to the AuthorisationTimespan (although it is likely that national laws will require it to be within the AuthorisationTimespan).

Table 8.4: TimeSpan structure

Field	Format	Description
StartTime	QualifiedDateTime (see ETSI TS 103 280 [7]).	Start time for the interception.
EndTime	QualifiedDateTime (see ETSI TS 103 280 [7]).	End time for the interception.
TerminationTime	QualifiedDateTime (see ETSI TS 103 280 [7]).	Termination or cancellation timestamp, in the event that the Task is terminated prior to its scheduled end time.
Provisioning Time	QualifiedDateTime (see ETSI TS 103 280 [7]).	Provisioning time for the interception.
DeprovisioningTime	QualifiedDateTime (see ETSI TS 103 280 [7]).	Deprovisioning time for the interception.

8.2.6 TargetIdentifier

8.2.6.1 Overview

The TargetIdentifier specifies the communications address or technical identifier used to identify the target of the Task. It consists of the following fields.

Table 8.5: TargetIdentifier

Field	Format	Description
TargetIdentifierValues	List of TargetIdentifierValue structures (see clause 8.2.6.2).	Specifies the technical identifier(s) used to identify the target of the Task.
ServiceType	ServiceType (see clause 8.2.6.4).	Specifies the service(s) to be intercepted.

8.2.6.2 TargetIdentifierValues Field

The TargetIdentifierValues field contains a list of TargetIdentifierValue structures, which are combined (with ordering and Boolean ANDed together) to identify the target's traffic. Each TargetIdentifierValue structure contains the following fields.

Table 8.6: TargetIdentifierValue

Field	Format	Description
FormatType	As defined below.	Specifies a Target Identifier Format (see below) which defines the format for the Target Identifier Value fields. See annex C for the list of Target Identifier Formats defined by ETSI. Other definitions may be managed on a national basis.
Value	LongString (see ETSI TS 103 280 [7]).	Additional formatting information is given by the Target Identifier Format.

The TargetIdentifier Format ID and format descriptions are given in annex C.

The Receiver is responsible for checking that the format of the Target Identifier Value matches the format defined for the Target Identifier Format Type. If any of the Target Identifier Values are not correctly formatted, the Action should be rejected.

8.2.6.3 FormatType

A TargetIdentifier Format Type uniquely identifies a particular TargetIdentifier Format. It can be used to retrieve the correct Target Identifier Format definition for a given Target Identifier. It consists of the following fields.

Table 8.7: TargetIdentifier Format Type

Field	Format	Description
FormatOwner	ShortString (see ETSI TS 103 280 [7]).	Name of the Owner of the Format definition. See below.
FormatName	ShortString (see ETSI TS 103 280 [7]).	Uniquely identifies the format definition within the Owner.

A Format owner is specified by a string value. The following owners are defined by the present document:

- "ETSI": The Format is owned by ETSI, and defined in the present document in annex C.
- A valid ISO 3166-1 [14] country code: The Format is owned and defined by the relevant national authority for the country specified by the country code.

A Format definition shall contain, at a minimum, the following information.

Table 8.8: TargetIdentifier Format Definition

Field	Format	Description
FormatOwner	ShortString (see ETSI TS 103 280 [7]).	Identifies the Owner of the Format definition. See below.
FormatName	ShortString (see ETSI TS 103 280 [7]).	Identifies the format, unique within the Format Owner.
Description	LongString (see ETSI TS 103 280 [7]).	Human-readable description associated with the Format.
Format	IEEE POSIX® 1003.1™ ERE [13] Regular Expression.	Regular expression defining the permissible contents of the field. If absent, any UTF-8 string is permitted, subject to the length restriction of the field.

See annex C for the list of TargetIdentifier Formats defined by ETSI. Other definitions may be managed on a national basis.

8.2.6.4 Task Service Type

Type of service or services to intercept using the specified TargetIdentifiers.

Given as a list of TaskServiceType DictionaryEntries. The usage and meaning of the Service Type is likely to be closely coupled to national legislation, as will the permissible combinations of TargetIdentifier Types and Service Types. It is therefore expected that most national profiles will need to define their own extensions to this dictionary.

Table 8.9: TargetServiceType Dictionary

Dictionary Owner	Dictionary Name
ETSI	TaskServiceType.
Defined DictionaryEntries	
Value	Meaning
The present document does not define any dictionary entries for this dictionary.	

8.2.7 DeliveryType

Delivery type of the Task. Given as a TaskDeliveryType DictionaryEntry. The TaskDeliveryType Dictionary is defined below (see annex F for more details on Dictionaries).

Table 8.10: TaskDeliveryType Dictionary

Dictionary Owner	Dictionary Name
ETSI	TaskDeliveryType.
Defined DictionaryEntries	
Value	Meaning
IRIOnly	Only IRI is delivered.
CCOnly	Only CC is delivered.
IRIandCC	Both IRI and CC are delivered.

8.2.8 TaskDeliveryDetails

8.2.8.1 Overview

The TaskDeliveryDetails field indicates where intercepted traffic should be delivered.

The TaskDeliveryDetails field consists of a list of DeliveryDestination structures. Each entry in the list represents a desired destination for traffic related to the Task.

Limits on the type, number or combinations of DeliveryDestination for a given type of Task shall be specified by the relevant national profile.

8.2.8.2 DeliveryDestination

The DeliveryDestination structure contains the following fields.

Table 8.11: DeliveryDestination structure

Field	Format	Description
DeliveryAddress	DeliveryAddress (see clause 8.2.8.3).	The address to which the traffic for this Task should be delivered.
EncryptionDetails	NationalEncryptionDetails.	Details regarding the encryption to be applied to traffic delivered to this destination. Shall be defined by the relevant national profile.
IRIorCC	TaskDeliveryType (see clause 8.2.7).	Specifies whether IRI, CC, or IRI and CC should be delivered to this destination.
HandoverFormat	HandoverFormat DictionaryEntry (see clause 8.2.8.4).	Specifies the handover format to be used.
DeliveryProfile	DictionaryEntry.	A dictionary entry which gives the name of a delivery profile that represents a set of configuration information associated with the destination and delivery of the traffic from this Task. If used, the dictionary shall be defined by the relevant national profile.
NationalDeliveryParameters	See annex G.	See annex G.

8.2.8.3 DeliveryAddress

The DeliveryAddress is specified in one of the following formats.

Table 8.12: DeliveryAddress structure

Field	Format	Description
IPv4Address	IPv4Address (see ETSI TS 103 280 [7]).	IPv4 destination.
IPv6Address	IPv6Address (see ETSI TS 103 280 [7]).	IPv6 destination.
IPAddressPort	IPAddressPort (see ETSI TS 103 280 [7]).	Combination of an IP Address (IPv4 or IPv6) and a Port number.
IPAddressPortRange	IPAddressPortRange (see ETSI TS 103 280 [7]).	Combination of an IP Address (IPv4 or IPv6) and a Port Range.
E164number	InternationalE164 (see ETSI TS 103 280 [7]).	E.164 destination.
FTPAddress	URL as per xs:anyURI but conformant to the FTP scheme defined in IETF RFC 1738 [8].	IETF RFC 1738 [8] allows specification of hostname, port, path and username.
URL	xs:anyURI.	URL destination.
FQDN	LongString (see ETSI TS 103 280 [7]).	FQDN of the destination.
EmailAddress	EmailAddress (see ETSI TS 103 280 [7]).	Email address of the destination.

8.2.8.4 HandoverFormat

The HandoverFormat dictionary is defined in table 8.13 (see annex F for more details on Dictionaries).

Table 8.13: HandoverFormat dictionary

Dictionary Owner	Dictionary Name
ETSI	HandoverFormat.
Defined DictionaryEntries	
Value	Meaning
TS102232-2	Handed over in ETSI TS 102 232-2 [15] format.
TS102232-3	Handed over in ETSI TS 102 232-3 [16] format.
TS102232-4	Handed over in ETSI TS 102 232-4 [17] format.
TS102232-5	Handed over in ETSI TS 102 232-5 [18] format.
TS102232-6	Handed over in ETSI TS 102 232-6 [19] format.
TS102232-7	Handed over in ETSI TS 102 232-7 [20] format.

8.2.9 ApprovalDetails

The ApprovalDetails field gives details regarding the approval for the Task. The information is specified in using the ApprovalDetails structure given in annex E.

8.2.10 CSPID

The CSPID field gives a globally unique CSP Identifier that identifies the CSP required to implement the Task.

8.2.11 HandlingProfile

The HandlingProfile field gives a dictionary entry which gives the name of a handling profile that represents a set of configuration information associated with this task.

The use of this field is for national agreement. If used, the dictionary of permissible values shall be defined by the relevant national profile.

8.2.12 Flags

The Flags field allows a set of multiple flags to be associated with the LITaskObject. Each flag is given as a TaskFlag Dictionary Entry. If a flag is present in the Flags field, then the meaning given as part of that flag's definition shall be taken to apply.

The TaskFlag Dictionary is defined in table 8.14 (see annex G for more details on Dictionaries).

Table 8.14: TaskFlag Dictionary

Dictionary Owner	Dictionary Name
ETSI	TaskFlag.
Defined DictionaryEntries	
Value	Meaning
IsTest	Indicates that the current Task is for test purposes. This may alter the process or documentation accompanying the authorisation.

8.3 LDTaskObject

8.3.1 Overview

An LDTaskObject represents the state of an LD task - that is, the act of disclosing information. This corresponds to the WarrantTargetID and WarrantTechSpec elements defined in ETSI TR 103 690 [i.1]. In general, multiple tasks may be authorised by a single warrant.

The LDTaskObject consists of the following fields.

Table 8.15: LDTaskObject

Field	Format	Description	Reference
Reference	LDID (see ETSI TS 103 280 [7]).	LDID assigned to the product of task.	Clause 8.3.2
Status	LDTaskStatus Dictionary Entry.	The current status of the task as determined by the Receiver.	Clause 8.3.3
StatusReason	ActionUnsuccessful structure (see clause 6.4.9).	Optional information for the Receiver to indicate why the Object is in a certain state (such as Invalid or Rejected). Usage for national agreement.	Clause 6.4.9
DesiredStatus	LDTaskDesiredStatus Dictionary Entry.	The current status of the task as specified by the Sender.	Clause 8.3.4
RequestDetails	LDRequestDetails (see clause 8.3.5).	Details regarding the content of the disclosure request, such as identifiers and dates.	Clause 8.3.5
DeliveryDetails	List of LDDeliveryDestination structures (see clause 8.3.6).	Destination(s) for the disclosure product.	Clause 8.3.6
ApprovalDetails	ApprovalDetails (see annex F).	Details regarding the approval for this Task, including dates and signatures where appropriate.	Clause 8.2.9
CSPID	EndpointID (see clause 6.2.4).	Describes the CSP required to implement the Task.	Clause 8.2.10
HandlingProfile	LDHandlingProfile (see clause 8.2.11).	A dictionary entry which gives the name of a handling profile that represents a set of configuration information associated with this task.	Clause 8.2.11
Flags	LDTaskFlags (see clause 8.3.7).	A set of flags associated with the Task Object.	Clause 8.3.7
NationalLDTaskingParameters	See annex G.	See annex G.	Annex G

8.3.2 Reference

The Reference field gives a reference identifier for the Task, for correlation with other processes. For LD, this shall be set to the LDID that will be assigned to the product of the disclosure. Format will be as per ETSI TS 103 280 [7].

8.3.3 Status

The Status field gives the status of the LDTaskObject as determined by the Receiver. A Sender shall not attempt to set the Status as part of a CREATE or UPDATE Request, and a Receiver shall return an Action Unsuccessful Information Response if the Sender attempts to do so.

The Status field provides a key mechanism for mapping the content of the Object to the relevant nationally-defined processes. The rules for evaluating the correct value of the Status field shall be defined in the relevant national profile.

Given as a LDTaskStatus Dictionary Entry. The LDTaskStatus Dictionary is defined in table 8.16 (see annex G for more details on Dictionaries).

Table 8.16: LDTaskStatus Dictionary

Dictionary Owner	Dictionary Name
ETSI	LDTaskStatus.
Defined DictionaryEntries	
Value	Meaning
AwaitingApproval	The Task is still waiting approval from one or more relevant authorities.
AwaitingDisclosure	The Task is approved, but is not yet processed by the LD system.
Disclosed	The Task has been processed and the product has been disclosed by the LD system.
DisclosureNotAvailable	The Task has been processed and the CSP has determined there is no product available to disclosure.
Rejected	The Task has been explicitly denied or rejected by one or more relevant authorities.
Cancelled	The Task has been permanently cancelled.
Error	The Task has not been processed due to a problem with the underlying LD system.
Invalid	The Task has not been processed to a problem with the current information populated in the Task Object.

8.3.4 DesiredStatus

The DesiredStatus field gives the status of the LDTaskObject as determined by the Sender.

Given as a LDTaskDesiredStatus Dictionary Entry. The LDTaskDesiredStatus Dictionary is defined in table 8.17 (see annex G for more details on Dictionaries).

Table 8.17: LDTaskDesiredStatus Dictionary

Dictionary Owner	Dictionary Name
ETSI	TaskDesiredStatus.
Defined DictionaryEntries	
Value	Meaning
AwaitingApproval	The Task is still waiting approval from one or more relevant authorities.
AwaitingDisclosure	The Task is approved, but is not yet processed by the LD system.
Disclosed	The Task has been processed and the product has been disclosed by the LD system.
Rejected	The Task has been explicitly denied or rejected by one or more relevant authorities.
Cancelled	The Task has been permanently cancelled.

8.3.5 RequestDetails

8.3.5.1 Overview

The RequestDetails structure specifies the content of the disclosure request. It consists of the following fields.

Table 8.18: LDRequestDetails

Field	Format	Description
Type	RequestType (see clause 8.3.5.2).	Specifies the products to be disclosed.
StartTime	QualifiedDateTime (see ETSI TS 103 280 [7]).	If a date/time range needs to be applied to the request, the StartTime and EndTime shall be provided.
EndTime	QualifiedDateTime (see ETSI TS 103 280 [7]).	If a date/time range needs to be applied to the request, the StartTime and EndTime shall be provided.
ObservedTime	QualifiedDateTime (see ETSI TS 103 280 [7]).	If an observed date/time needs to be applied to the request. This field may be used to indicate at which date/time a certain value was observed by the requestor.
RequestValues	List of RequestValue structures (see clause 8.3.5.3).	Specifies the value(s) used to define the disclosure request.

8.3.5.2 Type

Type of disclosure or disclosures to produce using the specified RequestDetails.

Given as a list of RequestType DictionaryEntries. The usage and meaning of the Request Type is likely to be closely coupled to national legislation, as will the permissible combinations of Request Values and Request Types. It is therefore expected that most national profiles will need to define their own extensions to this dictionary.

Table 8.19: RequestType Dictionary

Dictionary Owner	Dictionary Name
ETSI	RequestType.
Defined DictionaryEntries	
Value	Meaning
The present document does not define any dictionary entries for this dictionary.	

8.3.5.3 RequestValues

The RequestValues field contains a list of RequestValue structures, which are combined (with ordering and Boolean ANDed together) to identify the requested disclosure. Each RequestValue structure contains the following fields.

Table 8.20: RequestValues

Field	Format	Description
FormatType	As defined below.	Specifies a Request Value Format (see below) which defines the format for the Request Value fields. See annex C for the list of Request Value Formats defined by ETSI. Other definitions may be managed on a national basis.
Value	LongString (see ETSI TS 103 280 [7]).	Additional formatting information is given by the Request Value Format.

The Request Value Format ID and format descriptions are given in annex C.

The Receiver is responsible for checking that the format of the Request Value matches the format defined for the Request Value Format Type. If any of the Request Values are not correctly formatted, the Action should be rejected.

8.3.5.4 FormatType

A Request Value Format Type uniquely identifies a particular Request Value Format. It can be used to retrieve the correct Request Value Format definition for a RequestValues structure. It consists of the following fields.

Table 8.21: Request Value Format Type

Field	Format	Description
FormatOwner	ShortString (see ETSI TS 103 280 [7]).	Name of the Owner of the Format definition. See below.
FormatName	ShortString (see ETSI TS 103 280 [7]).	Uniquely identifies the format definition within the Owner.

A Format owner is specified by a string value. The following owners are defined by the present document:

- "ETSI": The Format is owned by ETSI, and defined in the present document in annex C.
- A valid ISO 3166-1 alpha-2 country code [14]: The Format is owned and defined by the relevant national authority for the country specified by the country code.

A Format definition shall contain, at a minimum, the following information.

Table 8.22: Request Value Format Definition

Field	Format	Description
FormatOwner	ShortString (see ETSI TS 103 280 [7]).	Identifies the Owner of the Format definition. See below.
FormatName	ShortString (see ETSI TS 103 280 [7]).	Identifies the format, unique within the Format Owner.
Description	LongString (see ETSI TS 103 280 [7]).	Human-readable description associated with the Format.
Format	IEEE POSIX® 1003.1™ ERE [13] Regular Expression.	Regular expression defining the permissible contents of the field. If absent, any UTF-8 string is permitted, subject to the length restriction of the field.

See annex C for the list of Request Value Formats defined by ETSI. Other definitions may be managed on a national basis.

8.3.6 DeliveryDetails

8.3.6.1 Overview

The LDTaskDeliveryDetails field indicates where disclosed product should be delivered.

The LDTaskDeliveryDetails field consists of a list of LDDeliveryDestination structures. Each entry in the list represents a desired destination for product related to the Task.

Limits on the type, number or combinations of LDDeliveryDestination for a given type of Task shall be specified by the relevant national profile.

8.3.6.2 LDDeliveryDestination

The LDDeliveryDestination structure contains the following fields.

Table 8.23: LDDeliveryDestination structure

Field	Format	Description
DeliveryAddress	DeliveryAddress (see clause 8.2.8.3).	The address to which the product for this Task should be delivered.
EncryptionDetails	NationalEncryptionDetails.	Details regarding the encryption to be applied to product delivered to this destination. Shall be defined by the relevant national profile.
HandoverFormat	LDHandoverFormat DictionaryEntry (see clause 8.3.6.3).	Specifies the handover format to be used.
DeliveryProfile	LDDeliveryProfile DictionaryEntry.	A dictionary entry which gives the name of a delivery profile that represents a set of configuration information associated with the destination and delivery of the product from this Task. If used, the dictionary shall be defined by the relevant national profile.
NationalDeliveryParameters	See annex G.	See annex G.

8.3.6.3 HandoverFormat

The LDHandoverFormat dictionary is defined in table 8.24 (see annex F for more details on Dictionaries).

Table 8.24: LDHandoverFormat dictionary

Dictionary Owner	Dictionary Name
ETSI	HandoverFormat
Defined DictionaryEntries	
Value	Meaning
TS102657	Handed over in ETSI TS 102 657 [22] format, using HI-B as described in [22].
EncapsulatedTS102657	Handed over as ETSI TS 102 657 [22] format, using the DeliveryObject as described in clause 10.
TS103120	Handed over using the DeliveryObject as described in clause 10.

8.3.7 Flags

The Flags field allows a set of multiple flags to be associated with the LDTaskObject. Each flag is given as a LDTaskFlag Dictionary Entry. If a flag is present in the Flags field, then the meaning given as part of that flag's definition shall be taken to apply.

The LDTaskFlag Dictionary is defined in table 8.25 (see annex G for more details on Dictionaries).

Table 8.25: LDTaskFlag Dictionary

Dictionary Owner	Dictionary Name
ETSI	LDTaskFlag.
Defined DictionaryEntries	
Value	Meaning
IsTest	Indicates that the current Task is for test purposes. This may alter the process or documentation accompanying the authorisation.

9 Transport and Encoding

9.1 Overview

This clause describes the transport and encoding mechanisms used in exchanging WI messages.

9.2 Encoding

9.2.1 XML Schema

Messages are encoded in XML format [4] according to the WI XSD Schema, which is provided as an XML XSD Schema Set that accompanies the present document. Each National Profile may, subject to national agreement, specify additional schema files that give definitions for national parameters (see annex G) that shall be considered as part of the schema set.

The Sender and Receiver shall only send messages that are successfully validated against the schema.

9.2.2 Error conditions

If a Receiver receives a WI Message which does not conform to the WI XSD Schema, it shall not attempt to process any of the contents. It shall respond with a top-level Action Unsuccessful message containing a suitable error code.

9.2.3 Message signing and encryption

Implementations may choose to digitally sign and/or encrypt messages for security and assurance purposes. If used, the signature information shall be placed in element as the last child element of the root message element.

If this is required, the relevant national profile shall specify the relevant details for populating the signature element. It is expected that future versions of the present document will include digital signature recommendation as defined by ETSI TC CYBER.

9.3 HTTP Transport

9.3.1 Use of HTTP

HTTP Transport is the defined transport mechanism for WI messages in the present document, unless a nationally-defined transport mechanism is to be used (see clause 9.4). For security details relating to the HTTP exchange, see clause 9.3.4.

9.3.2 Client/Server architecture

When using HTTP for WI message exchange, the Sender acts as an HTTP client while the Receiver acts as an HTTP server.

9.3.3 HTTP Configuration

The POST method shall be used for all HTTP requests. The body of the POST message shall contain a single HI1 Request Message, as defined in clause 5 and clause 6.3.1, and encoded as per clause 9.2.1.

The Content-Type shall be set to text/xml.

Cacheing shall not be used.

In the absence of HTTP transport level errors, the Receiver shall respond with an HTTP 200 OK response. The body of the response shall contain a single HI-1 Response Message, as defined in clause 5 and clause 6.3.1, and encoded as per clause 9.2.1. HTTP Status Codes shall not be used to indicate WI application layer errors. Well-formed WI Response messages containing the appropriate error codes shall be used.

9.3.4 Transport security

Implementations shall support HTTPS as defined in IETF RFC 2818 [5], including the support for mutual authentication through bidirectional certificate usage. Implementations shall use HTTPS unless specifically directed otherwise in the relevant national profile.

The use of pre-shared keys may be considered for authentication at the transport layer. If this option is selected, the specifications set forth in IETF RFC 4279 [6] shall be followed.

The relevant national profile shall provide details for the agreed security requirements for the transport layer, including specification of any necessary encryption, signatures or hash functions.

Issues such as key management, key length, key exchange, choice of cryptographic algorithm, etc. are outside of the scope of the present document. It is expected that future versions of the present document will include best practice recommendation as defined by ETSI TC CYBER.

9.4 Nationally-defined Transport

If HTTP transport as defined in the above clause is not to be used in a particular country, a nationally-defined alternative may be agreed on a national basis. Such a transport mechanism shall not break any of the requirements of the clause 9.2.

10 Delivery Object

10.1 Overview

A delivery Object represents the delivery of information to a request for that information as part of a task.

10.2 DeliveryObject

10.2.1 Overview

The DeliveryObject consists of the following fields. Where the DeliveryObject is created in response to a Task Object, that Task Object shall be referenced in the AssociatedObjects field of the DeliveryObject.

Table 10.1: DeliveryObject

Field	Format	Description	Reference
Reference	LDID (see ETSI TS 103 280 [7])	LDID assigned by the corresponding LDTaskObject.	Clause 8.3.2
DeliveryID	UUID (see ETSI TS 103 280 [7]) in IETF RFC 4122 [3] canonical form	A DeliveryID uniquely identifies this delivery. The delivery may be split using the SequenceNumber mechanism. The Manifest field applies to all sequences delivered under a single DeliveryID.	
SequenceNumber	Positive integer	An incremental and unique number within the scope of a DeliveryID. Starts with 1.	
LastSequence	Boolean	A boolean that indicates whether this was the last sequence for a DeliveryID. If there is only one SequenceNumber it shall be set to true.	

Field	Format	Description	Reference
Manifest	Manifest	The Manifest describes the format used in the delivery. It is recommended to transmit the manifest at the first sequence.	Clause 10.2.2
Delivery	Delivery	The actual delivery (or sequence of) the requested information.	Clause 10.2.3

10.2.2 Manifest

A Manifest structure is used to describe the format of a Delivery structure. The Manifest either points to existing formats (such as the format specified in ETSI TS 102 657 [22]) for the delivery of information but also supports a mechanism to attach a manifest to that delivery. An example of this is where a manifest is attached in the form of an XSD that describes the XML in the Delivery structure.

The Manifest consists of the following fields.

Table 10.2: Manifest

Field	Format	Description	Reference
Specification	Specification dictionary.	A dictionary describing the applicable ETSI TC-LI specifications that can be used in the Delivery structure. Alternatively, a ManifestID or ManifestType and Manifest shall be provided.	Table 10.3
ManifestID	LongString that uniquely identifies a certain manifest.	Instead of delivering ManifestContents, a ManifestID may be used to identify a certain manifest	
ManifestType	ShortString containing a MIME type as per IETF RFC 2045 [9] and IETF RFC 2046 [10].	The details of permissible MIME types shall be defined by the relevant national profile.	
ManifestContents	Binary data, represented using XSD's base64Binary type.	Binary representation of the manifest.	

Table 10.3: Specification Dictionary

Dictionary Owner	Dictionary Name
ETSI	ManifestSpecification
Defined DictionaryEntries	
Value	Meaning
TS102657-ASN.1	The delivery is according to ETSI TS 102 657 [22] using ASN.1 encoding.
TS102657-XML	The delivery is according to ETSI TS 102 657 [22] using XML encoding.

10.2.3 Delivery

A Delivery structure is used to deliver information as part of the DeliveryObject. If the sequencing mechanism in the DeliveryObject is used, the content in each Delivery structure may be a part of a file.

The Delivery structure consists of the following fields.

Table 10.4: Delivery

Field	Format	Description
Contents	Binary data, represented using XSD's base64Binary type.	Binary representation of the delivered content.
Content Type	ShortString containing a MIME type as per IETF RFC 2045 [9] and IETF RFC 2046 [10].	Encoding of the binary Contents file (e.g. "image/jpeg").
Checksum	UTF-8 string containing an SHA-256 checksum of the binary data, given as hexadecimal digits, as per IETF RFC 6234 [23].	Checksum to ensure that the Contents field has been transmitted correctly.

Annex A (informative): Example usage scenarios for HI-1

A.1 Overview

This annex shows some characteristics message flows for eWarrant exchange.

A.2 Direct communication

In this scenario the LEA directly requests warrant authorisation from a competent Warrant Approving Authority, and then passes the technical details for the interception on to the CSP for action.

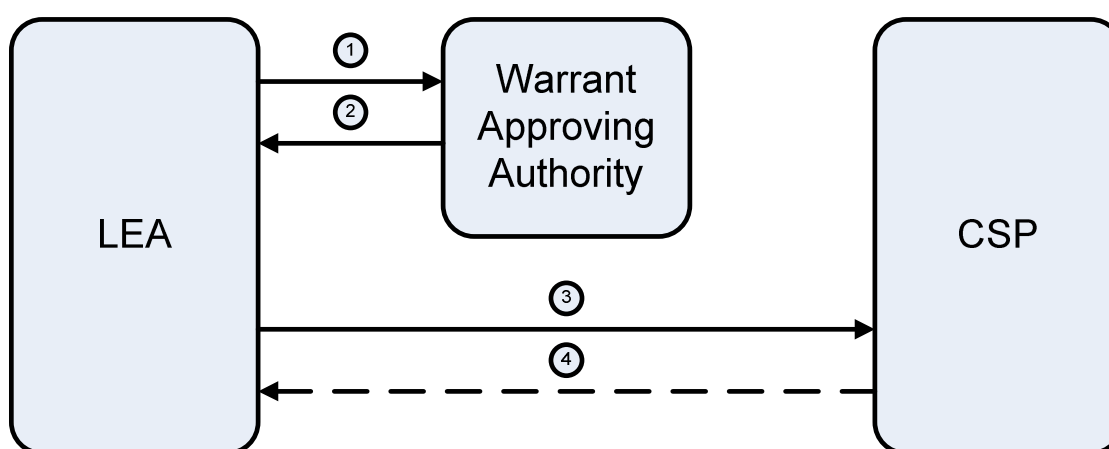

Figure A.1: Simple architecture for exchange of warrant and tasking information

The numbered message flows are as follows.

Table A.1: Message flows in Direct Communication

Message flow	Description	Information carried	Notes
1	Request for warrant approval.	Warrant information, plus any technical tasking information required.	
2	Approved/rejected warrant.	Warrant information.	If the warrant is not approved, #1 and #2 may be repeated.
3	Request for interception.	Tasking information, plus whatever subset of the warrant information is required.	
4	Intercepted product.	Intercepted product.	Covered by HI-2/3.

A.3 Single "Central Authority"

In this scenario, LEAs interact with the CSPs via a central broker authority. LEAs still interact with the warrant granting authorities directly.

The Central Authority may also take responsibility for fanning out an LEA's request to multiple CSPs, if appropriate.

Depending on the details of the jurisdiction, CSPs may or may not require a subset of the warrant information to be passed along with the tasking information.

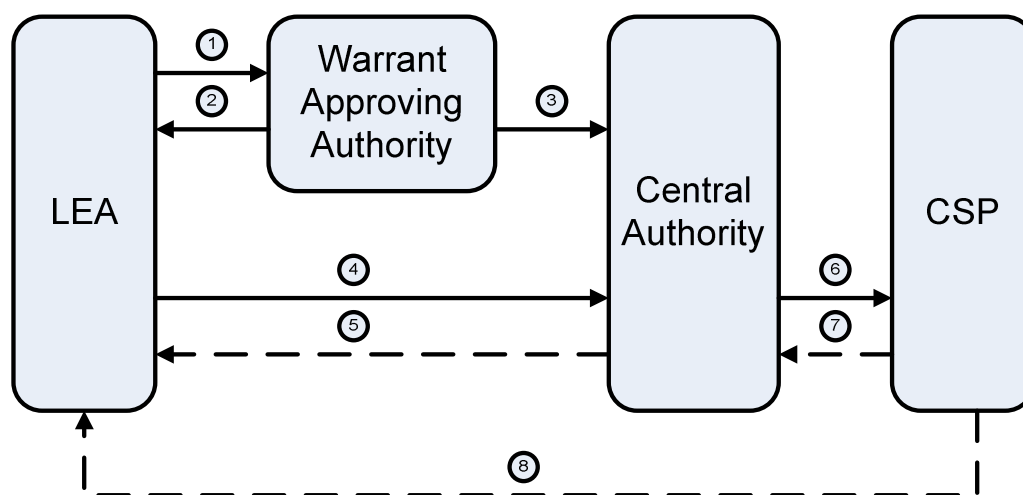

Figure A.2: Scenario including a Central Authority

The numbered message flows are as follows.

Table A.2: Message flows with a Central Authority

Message flow	Description	Information carried	Notes
1	Request for warrant approval.	Warrant information, plus any technical tasking information required.	
2	Approved/rejected warrant.	Warrant information.	If the warrant is not approved, #1 and #2 may be repeated.
3	Notification of approved warrant.	Warrant information.	Sent if the Central Authority requires some kind of external notification that the warrant is approved.
4	Request for interception.	Tasking information, plus any required subset of warrant information.	May include requests for tasking multiple CSPs.
5	Product of interception.	Intercepted product (if product is passed back via the Central Authority).	Covered by HI-2/3.
6	Request for interception.	Tasking information, plus any required subset of warrant information.	May be a subset of the information carried in #4.
7	Product of interception.	Intercepted product (if product is passed back via the Central Authority).	Covered by HI-2/3.
8	Product of interception.	Intercepted product (if product is passed back to the LEA directly).	Covered by HI-2/3.

A.4 Multiple Approving Authorities

A.4.1 Overview

In this scenario, the LEA's request for interception passes through two separate Approving Authorities for approval. In principle, this could be generated for three or more Approving Authorities.

A.4.2 "Serial" interaction

This may happen "serially", such that the first of the Warrant Approving Authorities is responsible for passing the relevant information on to the next Warrant Approving Authority. Information regarding the warrant is then passed back from the CSP in a similar way. In this scenario, the results of interception are passed directly to the LEA.

Although it is not shown here, it is possible that results of interception could also be mediated through one or more authorities, as in scenario A.2 above.

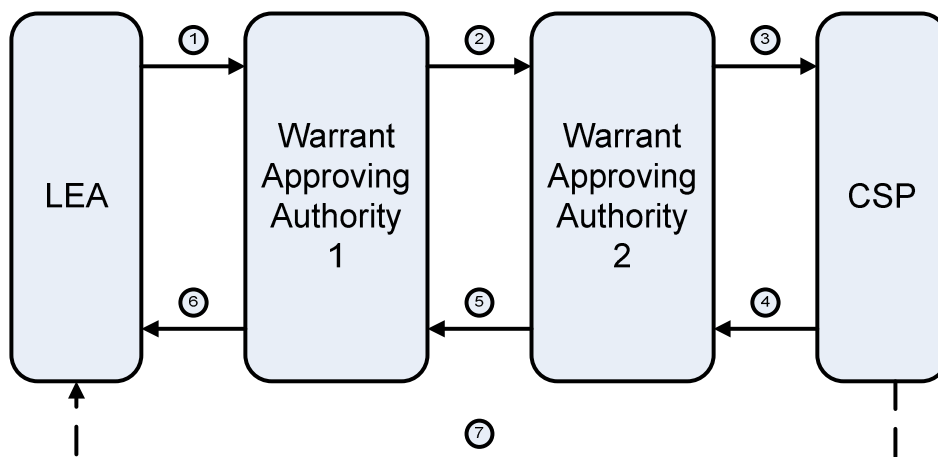

Figure A.3: Scenario with multiple Approving Authorities

The numbered message flows are as follows.

Table A.3: Message flows with multiple serial approving authorities

Message flow	Description	Information carried	Notes
1	Request for warrant approval.	Warrant information, plus any technical tasking information required.	
2	Request for warrant approval.	Warrant information (including approval from Warrant Approving Authority 1), plus any technical tasking information required.	If the warrant is not approved, a rejection may be sent back to the LEA.
3	Request for interception.	Tasking information, plus any required subset of warrant information.	Here, the last Approving Authority serves the warrant on the CSP.
4	Notification of activated warrant.	Tasking information.	Confirmation from the CSP that the warrant/task has been activated.
5	Notification of activated warrant.	Tasking information.	Confirmation from the CSP that the warrant/task has been activated.
6	Notification of activated warrant.	Tasking information.	Confirmation from the CSP that the warrant/task has been activated.
7	Product of interception.	Intercepted product (if product is passed back to the LEA directly).	Covered by HI-2/3.

A.4.3 "Parallel" interaction

This scenario may also happen "in parallel", where the LEA is responsible for presenting the warrant information to each of the Warrant Approving Authorities. Once the approvals have been collected, the LEA then submits the details of the interception required to the CSP directly.

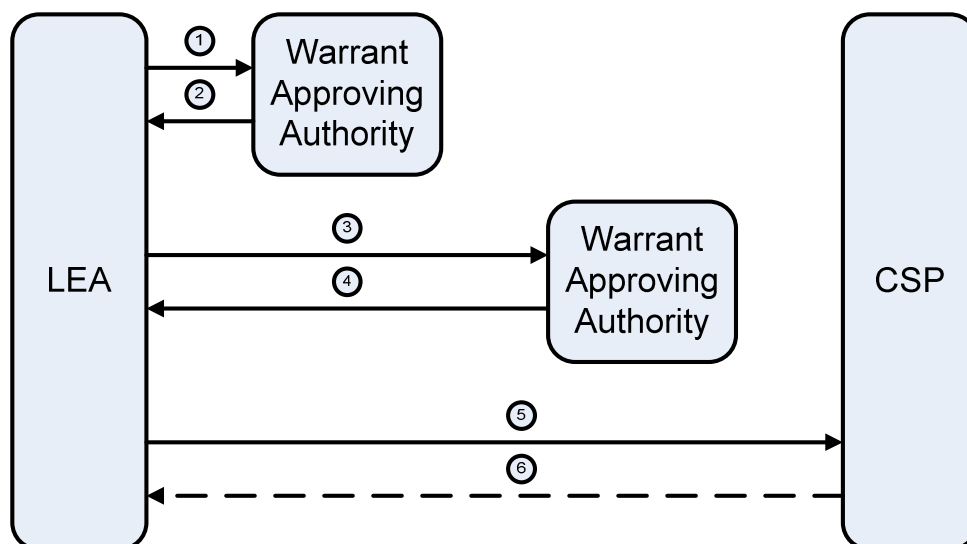

Figure A.4: Scenario with multiple Approving Authorities

The numbered message flows are as follows.

Table A.4: Message flows with multiple parallel approving authorities

Message flow	Description	Information carried	Notes
1	Request for warrant approval.	Warrant information, plus any technical tasking information required.	
2	Approved/rejected warrant.	Warrant information.	If the warrant is not approved, #1 and #2 may be repeated.
3	Request for warrant approval.	Warrant information, plus any technical tasking information required.	
4	Approved/rejected warrant.	Warrant information.	If the warrant is not approved, #3 and #4 may be repeated.
5	Request for interception.	Tasking information, plus any required subset of warrant information.	
6	Product of interception.	Intercepted product (if product is passed back to the LEA directly).	Covered by HI-2/3.

Annex B (informative): Example Template National Profile

B.1 Introduction

B.1.1 Overview

National tasking and warrant processes are tightly coupled to national legislation. While there are many broad similarities between different countries, the processes are subtly different in each country. The present document does not attempt to dictate these processes, but rather support whatever processes are required by national law.

To do so, the standard defines a common set of definitions for representing and exchanging authorisation and task information, but does not define the national business logic or rules that are applied to them. These are left to national jurisdictions to define in their national profiles of the present document.

This annex gives an example, or template, national profile. The purpose of this annex is as follows:

- To illustrate to readers of the standard how HI-1 can be used to build national processes.
- To demonstrate how the present document and a national profile are intended to interact.
- To give drafting guidance to those who are writing national profiles.

Clause B.1.2 gives a suggested structure and content for a national profile.

B.1.2 Structure of this annex

Clause B.2 contains an Example National Profile. It is written from the perspective of a fictional national jurisdiction, such that if the text in clause B.2 were made a separate document, it would form an illustrative example of a fictional national profile.

The content of B.1 (this clause) should be read as part of the present document. It provides the necessary explanation and background for the text in clause B.2.

B.1.3 Checklist for National Profile authors

The following list is provided as an informative checklist of the information that should be provided as part of a complete National Profile. The Example National Profile follows this checklist.

Table B.1: Requirements for national profiles

Item	ETSI Reference
The relevant national processes and reference model should be described or referenced, taking particular care to explain the desired mapping between HI-1 Objects and the things they represent in those national processes.	Clause 4
The correct value for the NationalProfileOwner has to be specified.	Clause 6.2.3
The correct value for the NationalProfileVersion field has to be specified.	Clause 6.2.3
The desired interoperability behaviour should be described.	Clause 6.2.3
The correct EndpointID country codes have to be specified.	Clause 6.2.4
The format or list of valid values for EndpointID Unique Identifiers have to be specified.	Clause 6.2.4
The profile has to specify whether use of the LIST verb is permitted.	Clause 6.4.8
If LIST is permitted, the rules for determining which Object Identifiers are returned have to be specified.	Clause 6.4.8
If LIST is permitted, any additional rules relating to LIST responses (e.g. size of response, caching behaviour) may be specified.	Clause 6.4.8
If LIST is permitted, any additional logic related to listing Notification Objects may be specified.	Clause 6.4.7

Item	ETSI Reference
The national profile has to make a statement about whether each field in each HI-1 Object definition are required in order for an instance of the object to be valid.	Clause 7.1
The valid format or values for Owner Identifier have to be specified.	Clause 7.1.1
NationalHandlingParameters may be defined.	Clause 7.1.6
The correct format or values for AuthorisationReference have to be specified.	Clause 7.2.2
The correct format or values for AuthorisationLegalType have to be specified.	Clause 7.2.3
The usage of AuthorisationPriority has to be specified. Any additional clarifications or DictionaryEntries may be specified.	Clause 7.2.4
The rules for determining the value of the AuthorisationStatus field have to be specified. The business meaning of each Status should be specified. Any additional clarifications or DictionaryEntries may be specified.	Clause 7.2.5
The business meaning of each Status should be specified. Any additional clarifications or DictionaryEntries may be specified.	Clause 7.2.6
Usage and meaning of the IsEmergency flag have to be specified.	Clause 7.2.12
Any additional clarifications or DictionaryEntries for Flags field may be specified.	Clause 7.2.12
The correct format or values of the DocumentReference field have to be specified.	Clause 7.3.2
The correct usage of the DocumentName field has to be specified.	Clause 7.3.3
The rules for determining the value of the DocumentStatus field have to be specified. The business meaning of each Status should be specified. Any additional clarifications or DictionaryEntries may be specified.	Clause 7.3.4
The business meaning of each Status should be specified. Any additional clarifications or DictionaryEntries may be specified.	Clause 7.3.5
The list of permissible of DocumentTypes has to be specified.	Clause 7.3.7
The list of permissible of DocumentProperties has to be specified.	Clause 7.3.8
The list of permissible MIME types for the DocumentBody field has to be specified.	Clause 7.3.9
The profile has to specify whether use of Notification Objects is permitted.	Clause 7.4.1
If NotificationObjects are used, the format and usage of the NotificationType field have to be specified.	Clause 7.4.3
If NotificationObjects are used, the correct archiving and persistence behaviour for NotificationObjects once the NewNotification flag has been cleared have to be specified.	Clause 7.4.4
If NotificationObjects are used, the definition of NationalNotificationParameters may be specified.	Clause 7.4.6
The rules for determining the value of the LITaskObject Status field have to be specified. The business meaning of each Status should be specified. Any additional clarifications or DictionaryEntries may be specified.	Clause 8.2.3
The business meaning of each Status should be specified. Any additional clarifications or DictionaryEntries may be specified.	Clause 8.2.4
Additional TargetIdentifier FormatTypes may be defined.	Clause 8.2.6.3
The list of valid TaskServiceTypes has to be specified.	Clause 8.2.6.4
Additional clarifications and DictionaryEntries for the DeliveryType may be defined.	Clause 8.2.7
NationalDeliveryParameters may be defined.	Clause 8.2.8.2
Additional clarifications and DictionaryEntries for the HandoverFormat may be defined.	Clause 8.2.8.4
DictionaryEntries for the HandlingProfile may be defined.	Clause 8.2.11
Additional clarifications and DictionaryEntries for the Flags field may be defined.	Clause 8.2.12
Additional schema fields may be specified.	Clause 9.2.1
Use of message signature and message encryption may be specified. If they are, the required signature and encryption details have to be specified.	Clause 9.2.3
Implementers may be directed not to use HTTPS.	Clause 9.3.4
National requirements for transport encryption and authentication have to be specified.	Clause 9.3.4
Additional error codes may be specified.	Annex D
The usage and valid format for ApprovalType have to be specified.	Clause E.2
The usage and valid format for ApprovalDescription may be specified.	Clause E.3
The usage and valid format for ApprovalReference have to be specified.	Clause E.4
The usage and valid format for ApprovalRole have to be specified.	Clause E.5.1
NationalApproverIdentity may be defined.	Clause E.5.2
Definition of the usage of ApprovalsEmergency has to be specified.	Clause E.7
NationalDigitalSignature details may be defined.	Clause E.8

B.1.4 Details of the fictional national jurisdiction

For the purposes of the Example National Profile, it is assumed there is a fictional national jurisdiction.

This jurisdiction has a country code of "XX", which is a reserved ISO 3166-1 [14] alpha-2 country code.

The jurisdiction has a national process which follows the model given in clause A.2 of the present document. For simplicity and brevity, the jurisdiction is only using the present document to exchange information between the LEA and the CSP. It is assumed that the earlier interactions between the LEA and the warrant signing authority have occurred.

B.2 Example National Profile

B.2.1 Approach and reference model

B.2.1.1 Overview

This national profile follows ETSI TS 103 120 (the present document). The approach, structure of this national profile, and reference model follow the details given in clause 4, subject to the following clarifications and additions.

This national profile defines how ETSI TS 103 120 (the present document) is to be used for interactions between an LEA and a CSP. Specifically, the interactions covered by this national profile are as follows:

- Communication of a new Warrant, and associated Tasking instructions.
- Cancellation of an existing Warrant.
- Communication of a new Tasking Instruction under an existing Warrant.

B.2.1.2 Warrants

A new Warrant is created by obtaining a Warrant Instrument from the Warrant Issuing Authority. A Warrant Instrument is represented by a Document Object. For a Warrant Instrument to be valid, it has to contain:

- A Warrant Reference, consisting of the letter "W" followed by a six-digit number.
- The name of the person signing the Warrant Instrument.
- A signature date, in the past.
- A end date, later than the start date.

A Warrant is cancelled by obtaining a Cancellation Instrument from the Warrant Issuing Authority. A cancelled Warrant automatically stops all Tasking Instructions related to that Warrant. For a Cancellation Instrument to be valid, it has to contain:

- A valid Cancellation Reference, consisting of the letter "C", followed by a six-digit number.
- The name of the person signing the Cancellation Instrument.
- A signature date, in the past.

B.2.1.3 Tasking Instructions

A Tasking Instruction is issued as part of a Warrant by the LEA.

For a Tasking Instruction to be valid, it has to:

- Be part of a valid Warrant.
- Have a valid LIID.
- Specify the communications address to be intercepted. The only valid type of communications address is MSISDN.

- Specify the time period inside which interception is sought, which has to be within the period of validity of the Warrant.

B.2.1.4 Representation by HI-1 Objects

Figure B.1 shows how the concepts described in the previous clauses are represented by HI-1 Objects.

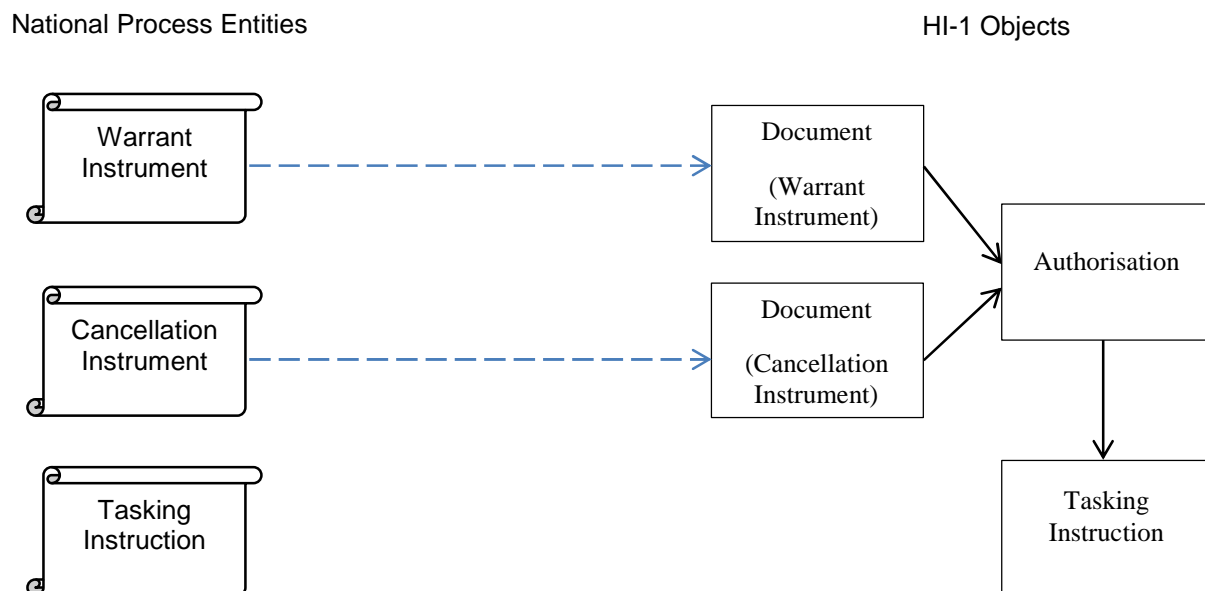

Figure B.1: Mapping of concepts to HI-1 Objects

B.2.2 Message Structure

B.2.2.1 Overview

The details in clause 6 have to be followed, subject to the following clarifications and additions in this clause.

B.2.2.2 Version information

The NationalProfile Owner is set to "XX".

The NationalProfileVersion is set to "v1.0".

Future versions of this national profile will specify interoperability requirements.

B.2.2.3 Sender and Receiver Identifiers

The Sender Identifier and Receiver Identifiers have a country code of "XX".

The Sender and Receiver Unique Identifier fields consist of eight alphanumeric characters.

B.2.2.4 LIST semantics

The Receiver has to support the LIST verb.

The Receiver can only return Object Identifiers for HI-1 Objects that are owned by the Sender (that is, the Sender Identifier matches the Object's Owner Identifier).

The number of matches returned is not to be limited.

B.2.3 Data Definitions

B.2.3.1 Overview

The details in clause 7 are followed, subject to the following clarifications and additions.

B.2.3.2 Object Identifiers

Object Identifiers are created with a country code of "XX".

The Object Identifier Owner Identifier is set to the Sender Identifier of the Sender that created the Object.

The Object Identifier External Identifier field is not populated.

B.2.3.3 Generic Object Fields

The National Handling Parameters is not to be used.

B.2.3.4 Authorisation Objects

The Authorisation Object is to be subjected to the following additional guidance.

Table B.2: Authorisation Object

Field	Usage	Additional guidance
AuthorisationReference	Used	Set to the Warrant Reference of the associated Warrant Instrument, in the same format (see Document Object, clause B.2.3.5).
AuthorisationLegalType	Not Used	
AuthorisationPriority	Not Used	
AuthorisationStatus	Used	No additional AuthorisationStatus DictionaryEntries are defined. The rules for calculating the correct AuthorisationStatus value are given below table B.2.
AuthorisationDesiredStatus	Not Used	
AuthorisationTimespan	Used	Set to match the validity period of the associated Warrant Instrument Document Object.
AuthorisationCSPID	Not Used	
AuthorisationCreationTimestamp	Not Used	
AuthorisationServedTimestamp	Not Used	
AuthorisationTerminationTimestamp	Used	If the Authorisation Object is associated with a Cancellation Instrument Document Object, this field is set to the signature date of the associated Cancellation.
AuthorisationApprovalDetails	Not Used	
AuthorisationInvalidReason	Used	Populated by the Receiver if the AuthorisationStatus is "Invalid", absent otherwise.
AuthorisationFlags	Not Used	
NationalAuthorisationParameters	Not Used	

The Status field of an Authorisation Object is set according to the following rules, applied in the order given:

- If any of the other fields in the Authorisation Object do not conform to the relevant format as defined in this national profile, then the Status is "Invalid".
- If the Authorisation Object is not associated with a valid Document Object representing a Warrant Instrument, then the Status is "Invalid".
- If the Authorisation Object is associated with a valid Document Object representing a Cancellation Instrument, then the Status is "Cancelled".
- If the Authorisation does not have an AuthorisationTimespan StartTime after the date of the signature of the associated Warrant Instrument Document Object, the Status is "Invalid".

- If the Authorisation does not have an AuthorisationTimespan EndTime before the end date of the associated Warrant Instrument Document Object, the Status is "Invalid".
- If the Authorisation has an AuthorisationTimespan end time in the past, then the Status has to be set to "Expired".
- In all other cases, the Authorisation Status is "Approved".

B.2.3.5 Document Objects

The Document Object is subject to the following additional guidance.

Table B.3: Document Object

Field	Usage	Additional guidance
DocumentReference	Used	For Warrant Instruments, this field is set to the Warrant Reference, given as the letter "W" followed by a six digit number. For Cancellation Instruments, this field is set to the Cancellation Reference, given as the letter "C" followed by a six digit number.
DocumentName	Not Used	Name for a specific document.
DocumentStatus	Used	No additional DocumentStatus DictionaryEntries are defined. The rules for calculating the correct DocumentStatus value are given below.
DocumentDesiredStatus	Not Used	
DocumentTimespan	Used	Start time is set to the date of signature. For Warrant Instruments, the End time is set to the end of the validity of the Warrant. For Cancellation Instruments, the End time is absent.
DocumentType	Used	Additional guidance and DictionaryEntry definitions are given below.
DocumentProperties	Not Used	
DocumentBody	Not Used	
DocumentSignature	ApprovalDetails (see annex F)	Additional guidance given below table B.3.
NationalDocumentParameters	Not Used	

The DocumentStatus field of a Document Object is set according to the following rules, applied in the order given:

- If the Document does not have a valid DocumentSignature block, the Status is "Invalid".
- If the DocumentType is set to anything other than "Warrant Instrument" or "Cancellation Instrument", then the Status is "Invalid".
- If the DocumentType is "Warrant Instrument", and the Document does not have a DocumentTimespan EndDate, then the Status is "Invalid".
- In all other cases, the Status is "Approved".

The following additional DocumentType DictionaryEntries are defined.

Table B.4: National DocumentType Dictionary

Dictionary Owner	Dictionary Name
CountryXX	DocumentType.
Defined DictionaryEntries	
Value	Meaning
Cancellation	This Document represents a Cancellation Instrument.

The ETSI-defined DocumentType DictionaryEntries have the following additional meaning.

Table B.5: ETSI DocumentType Dictionary

ETSI-Defined DictionaryEntries	
Value	Additional Meaning
Warrant	This Document represents a Warrant Instrument.

The ApprovalDetails fields are populated as follows.

Table B.6: ETSI Document ApprovalDetails

Field	Used	Additional Guidance
ApprovalType	Not Used	
ApprovalDescription	Not Used	
ApprovalReference	Not Used	
ApproverDetails	ApproverDetails	See table B.7.
ApprovalTimestamp	Used	Given as the time of the signature.
ApprovalsEmergency	Not Used	
ApprovalDigitalSignature	Not Used	
ApprovalNationalDetails	Not Used	

Table B.7: ETSI Document ApproverDetails

Field	Used	Description
ApproverName	Used	Name or other identifier of the approver.
ApproverRole	Not Used	
ApproverIdentity	Not Used	

B.2.3.6 Notification Objects

Notification Objects are not used.

B.2.3.7 LITaskObjects

The LITaskObject is subject to the following additional guidance.

Table B.8: LITaskObject

Field	Used	Additional guidance
Reference	Used	LIID assigned to the product of task.
Status	Used	No additional Status DictionaryEntries defined. The rules for calculating the correct Status value are given below table B.8.
DesiredStatus	Not Used	
TimeSpan	Not Used	
TargetIdentifier	Used	Contains the desired Target Identifier. Contains a single Target Identifier of type InternationalE164.
DeliveryType	Used	No additional guidance.
DeliveryDetails	Used	No additional guidance.
ApprovalDetails	Not Used	
CSPID	Used	No additional guidance.
HandlingProfile	Not Used	
InvalidReason	Used	Populated by the Receiver if the AuthorisationStatus is "Invalid", absent otherwise.
Flags	Not Used	
NationalLITaskingParameters	Not Used	

The Status field of a LITaskObject is set according to the following rules, applied in the order given:

- If the Task Object is not associated with an Authorisation Object, then the Status is "Invalid".
- If the Task Object is associated with an Authorisation Object's whose status is "Cancelled", then the Task Object's Status is "Cancelled".
- If the Task Object is associated with an Authorisation Object's whose status is anything other than "Approved", then the Task Object's Status is "Invalid".
- If the Task Object does not have a valid LIID, then the Status is "Invalid".
- If the Task Object does not have a Target Identifier, then the Status is "Invalid".
- If the Task Object has a Target Identifier which is not of type "MSISDN", then the Status is "Invalid".
- If the Task Object does not have a TaskTimeSpan StartTime equal to or later than the associated Authorisation Start Time, then the Status is "Invalid".
- If the Task Object does not have a TaskTimeSpan EndTime equal to or earlier than the associated Authorisation End Time, then the Status is "Invalid".
- If the Task Object's TaskTimeSpan EndTime is in the past, then the Status is "Expired".
- If the Task requests data outside the bounds of the associated Authorisation (e.g. CC for IRI only warrant), then the Task Object Status is "Rejected".
- If the underlying LI system has an error related to this Task, then the Status is "Error".
- In all other cases, the Task Object Status is "Active".

B.2.4 Transport and Encoding

The details in clause 9 are followed.

XML message is not signed nor encrypted.

The present document does not specify any nationally-defined transport mechanisms.

HTTPS is used. For details on the current security requirements and considerations for the transport layer, please contact the national regulator.

B.2.5 Example XML

B.2.5.1 Introduction

The following example XML messages illustrate both the principles of HI-1 and the application to this national profile. The scenario is not an example of good programming practice or application design, but is intended to highlight some of the key aspects of HI-1.

The example messages consist of three transactions:

Request 1: In the first request message, the Sender asks to CREATE an Authorisation Object, and an associated LITaskObject which is associated to it.

Response 1: The Receiver responds, indicating that both CREATE Requests were accepted, but not returning any further information.

Request 2: The Sender asks to retrieve the current state of the Authorisation Object and the LITaskObject.

Response 2: The Receiver supplies the current state of both. It can be seen that both are "Invalid", since the Authorisation Object is not associated with a valid Document Object, as per the details AuthorisationStatus rules given above.

Request 3: The Sender issues a CREATE request to create the relevant Document Object, and an UPDATE to associate the Authorisation Object with the newly created Document Object.

Response 3: The Receiver indicates that both requests succeeded. Further, in the UPDATE Response, it provides an updated view of the state, which shows that the Authorisation is now in the "Active" state.

Request 4: In the first request message, the Sender asks to CREATE an Authorisation Object, and an associated LDTaskObject which is associated to it.

Response 4: The Receiver responds, indicating that both CREATE Requests were accepted, but not returning any further information.

Response 4 (delivery): The Receiver responds, returning a DeliveryObject in response to the lawful disclosure request in the LDTaskObject.

The example XML can be found in in the attachment provided with the present document and contained in archive ts_103120v010401p0.zip.

B.2.5.2 Void

Void.

B.2.5.3 Void

Void.

B.2.5.4 Void

Void.

B.2.5.5 Void

Void.

B.2.5.6 Void

Void.

B.2.5.7 Void

Void.

Annex C (normative): ETSI Target Identifier and Request Value Format Definitions

C.1 Overview

This annex details the baseline set of Target Identifier and Request Value Formats that are defined and managed by ETSI. This list covers the majority of identifier formats used in the ETSI TC LI family of LI and LD handover standards. It is expected that some Target Identifier and Request Value Formats will need to be used in combination with each other (e.g. UDPPortRange and IPv4Address).

C.2 Definitions

Table C.1: ETSI Target Identifier and Request Value Format Definitions

Format Name	Description	Format
E.164	E.164 [i.9] Number in fully international format, excluding the '+' prefix, written as decimal digits.	Regular expression as per ETSI TS 103 280 [7] InternationalE164 format
IMSI	International Mobile Subscriber Identity, following the Recommendation ITU-T E.212 [i.10] numbering scheme, written as decimal digits.	Regular expression as per ETSI TS 103 280 [7]
IMEI	International Mobile station Equipment Identity, following the numbering plan defined in ETSI TS 123 003 [i.6], written as decimal digits without the Luhn check digit.	Regular expression as per ETSI TS 103 280 [7]
IMEICheckDigit	International Mobile station Equipment Identity, following the numbering plan defined in ETSI TS 123 003 [i.6], written as decimal digits with the Luhn check digit.	Regular expression as per ETSI TS 103 280 [7]
IMEISV	International Mobile station Equipment Identity Software Version, following the numbering plan defined in ETSI TS 123 003 [i.6], written as decimal digits including the two SV digits.	Regular expression as per ETSI TS 103 280 [7]
MACAddress	A MAC address in IEEE Std 802-2001™ [i.8] 48-bit format, written as six pairs of hexadecimal digits separated by colons.	Regular expression as per ETSI TS 103 280 [7]
IPv4Address	IPv4 address in dotted decimal notation.	Regular expression as per ETSI TS 103 280 [7]
IPv6Address	IPv6 address as colon-separated hexadecimal digits.	Regular expression as per ETSI TS 103 280 [7]
IPv4CIDR	IPv4CIDR, written in dotted decimal notation followed by CIDR notation.	Regular expression as per ETSI TS 103 280 [7]
IPv6CIDR	IPv6CIDR written as eight groups of four hexadecimal digits separated by a colon, followed by CIDR notation.	Regular expression as per ETSI TS 103 280 [7]
TCPPort	TCP Port number, written in decimal notation.	Regular expression as per ETSI TS 103 280 [7]
TCPPortRange	Range of TCP Ports, written as decimal numbers separated by a colon.	Regular expression as per ETSI TS 103 280 [7]
UDPPort	UDP Port number, written in decimal notation.	Regular expression as per ETSI TS 103 280 [7]
UDPPortRange	Range of UDP Ports, written as decimal numbers separated by a colon.	Regular expression as per ETSI TS 103 280 [7]
Port	Port number given as a decimal number.	Regular expression as per ETSI TS 103 280 [7]
PortRange	Range of port numbers, given as decimal numbers separated by a colon.	Regular expression as per ETSI TS 103 280 [7]
EmailAddress	Email address following W3C HTML 5 Recommendation [12].	Regular expression as per ETSI TS 103 280 [7]
SIP-URI	SIP-URI according to the SIP URI scheme (see IETF RFC 3261 [i.2]/ETSI TS 124 229 [i.7]).	Regular expression as per ETSI TS 103 280 [7]
TEL-URI	tel-URI according to the tel URI scheme (see IETF RFC 3966 [i.3]).	Regular expression as per ETSI TS 103 280 [7]

Format Name	Description	Format
H323-URI	H323 URI according to the H323 URI scheme (see IETF RFC 3508 [i.4]).	^h323:[a-zA-Z0-9!#\$&-;=?-\[\]_~%]+\$
IMPU	IP Multimedia Public Identity, as per ETSI TS 123 003 [i.6].	^[a-zA-Z0-9!#\$&-;=?-\[\]_~%]+\$
IMPI	IP Multimedia Private Identity, as per ETSI TS 123 003 [i.6].	^[a-zA-Z0-9!#\$&-;=?-\[\]_~%]+\$
NAI	Network Access Identifier following IETF RFC 4282 [i.5] format.	Regular expression as per ETSI TS 103 280 [7]
SUPIIMSI	Subscription Permanent Identifier in IMSI representation as defined in ETSI TS 123 501 [21].	Regular expression as per ETSI TS 103 280 [7]
SUPINAI	Subscription Permanent Identifier in NAI representation as defined in ETSI TS 123 501 [21].	Regular expression as per ETSI TS 103 280 [7]
PEIIMEI	Permanent Equipment Identifier in IMEI representation as defined in ETSI TS 123 501 [21].	Regular expression as per ETSI TS 103 280 [7]
PEIIMEICheckDigit	Permanent Equipment Identifier in IMEI representation as defined in ETSI TS 123 501 [21].	Regular expression as per ETSI TS 103 280 [7]
PEIIMEISV	Permanent Equipment Identifier in IMEI SV representation as defined in ETSI TS 123 501 [21].	Regular expression as per ETSI TS 103 280 [7]
GPSIMSISDN	General Public Subscription Identifier as defined in ETSI TS 123 501 [21] in MSISDN representation.	Regular expression as per ETSI TS 103 280 [7]
GPSINAI	General Public Subscription Identifier as defined in ETSI TS 123 501 [21] in NAI representation.	Regular expression as per ETSI TS 103 280 [7]

Annex D (normative): Error Codes

D.1 Detailed error codes

Table D.1: Detailed Error Codes

Error Code	Error Description	Message Element
3000	General Business Logic Error.	
3001	Feature Not Supported.	
3002	Duplicate ActionID detected.	
3003	Transient Technical Error.	"Call us if this persists"
3004	Configuration Issue - <Customize element>.	Indicates portal element to configure (Example: Legal Order Type configuration)
	Message Element Checks.	
3005	Required element missing. (Mandatory per national profile.) (Example: Valid CSPID present.)	Specific element type from the message header or object structure is cited. (Object reference if applicable) ObjectID: <Object_Value>: <Element name>
3006	Value change not allowed. (Update operations.)	Specific element type from the message header or object structure is cited. (Object reference if applicable) ObjectID: <Object_Value>: <Element name>
3007	Improper value. (Semantic value does not fit context. Schema validation catches syntactic.)	Specific element type from the message header or object structure is cited. (Object reference if applicable) ObjectID: <Object_Value>: <Element name>
3008	Improper value change. (New value not allowed.)	Specific element type from the message header or object structure is cited. (Object reference if applicable) ObjectID: <Object_Value>: <Element name>
3009	Value not found in system. (Reference to previous system value.)	Specific element type from the message header or object structure is cited. (Object reference if applicable) ObjectID: <Object_Value>: <Element name>
	Object Reference Checks.	
3010	Attempt to Create an Object that already exists.	Object_ID: <Object_Value>
3011	Attempt to Update an Object that does not exist.	Object_ID: <Object_Value>
3012	Attempt to Update an Object that has Expired. (Question on reuse and impact on audits.)	Object_ID: <Object_Value>
3013	Attempt to Cancel an Object that does not exist.	Object_ID: <Object_Value>
3014	Attempt to Get an Object that cannot be found.	Object_ID: <Object_Value>
3015	Attempt to Get an Object that was found but not deliverable via tasking interface. (Object may have been archived.)	Object_ID: <Object_Value>
3016 (3200)	Attempt to link an Object to an Associated Object that does not exist.	Linked_From_Object_ID: <Object_Value> Linked_To_Object_ID: <Object_Value>
3017	Attempt to link an Object to an Associated Object that has Expired. (Question on reuse and impact on audits.)	Linked_From_Object_ID: <Object_Value> Linked_To_Object_ID: <Object_Value>
3018	Attempt to link an Object to an Associated Object that failed. (Two objects sent in same message.) (Example: <3106> Warrant doc delivery.)	Linked_From_Object_ID: <Object_Value> Linked_To_Object_ID: <Object_Value>
3019-3999	Reserved for future Errors.	
4000-4999	Reserved for nationally-defined Error Codes.	The relevant national profile may specify additional error codes in this range

Annex E (normative): Approval Details

E.1 Overview

The ApprovalDetails type contains a list of ApprovalInformation structures. An individual approval may be represented by the ApprovalInformation structure, defined by table E.1. This structure documents the nature of an approval and the details of the signatures on such actions.

Table E.1: ApprovalInformation

Field	Format	Description	Reference
ApprovalType	LongString (see ETSI TS 103 280 [7])	Defines the nature of the approval: e.g. Creation, Renewal, Modification, Cancellation.	E.2
ApprovalDescription	LongString (see ETSI TS 103 280 [7])	Human readable description of what elements of the authorisation were changed.	E.3
ApprovalReference	LongString (see ETSI TS 103 280 [7])	Nationally defined reference for the Approval, provided to allow correlation with non-HI-1 processes.	E.4
ApproverDetails	ApproverDetails	Gives details of who gave the Approval.	E.5
ApprovalTimestamp	QualifiedDateTime (see ETSI TS 103 280 [7])	Indicates when the Approval was given or signed.	E.6
ApprovalsEmergency	Boolean	Flag to indicate that this was an emergency change.	E.7
ApprovalDigitalSignature	Complex Type (see clause E.8)	Provides digital signature information relating to the approval.	E.8
ApprovalNationalDetails	Complex Type	Provides national-specific data elements associated with an approval.	

E.2 ApprovalType

The ApprovalType field is used to indicate the type of approval being given. The acceptable values and business meaning of this field shall be defined by the relevant national profile.

E.3 ApprovalDescription

The ApprovalDescription field is used to provide a human readable description of the contents of authorisation. This may include a human-readable description of what is being authorised, or other process or legal information (e.g. "boilerplate" text) that may be relevant to the approval. The precise contents and meaning of this field will be defined by the relevant national profile.

E.4 ApprovalReference

The ApprovalReference field is a nationally-defined reference for the Approval, provided to allow correlation with non-HI-1 processes. The precise contents and meaning of this field will be defined by the relevant national profile.

E.5 ApproverDetails

E.5.1 Overview

The ApproverDetails gives details of the person, role or other entity that is granting the Approval. It consists of the following fields.

Table E.2: ApproverDetails

Field	Format	Description
ApproverName	LongString (see ETSI TS 103 280 [7]).	Name or other identifier of the approver.
ApproverRole	LongString (see ETSI TS 103 280 [7]).	Nationally-defined role of the Approver (e.g. rank, post or office).
ApproverIdentity	ApproverIdentity (see clause E.5.2).	Identity of the Approver given in a machine-readable format.

E.5.2 ApproverIdentity

The ApproverIdentity field asserts the identity of the approver in a machine-readable form.

The ApprovalIdentity field contains one of the following structures.

Table E.3: ApproverIdentity

Field	Format	Description
NationalApproverIdentity	Defined by the relevant national profile.	Nationally-defined digital signature details.

It is important that on a national basis appropriate measures are in place, either digitally or through other processes, to provide appropriate identity details. It is expected that future versions of the present document will include digital signature recommendation as defined by ETSI TC CYBER.

E.6 ApprovalTimestamp

The ApprovalTimestamp field is used to indicate when the Approval was given, in ISO date-time format with an explicit timezone indication.

E.7 ApprovalsEmergency

The ApprovalsEmergency field is used to indicate whether the Approval has been given under emergency circumstances. The definition of "emergency circumstances" and the use of this field will be given in the relevant national profile.

E.8 ApprovalDigitalSignature

E.8.1 Overview

The ApprovalDigitalSignature field is used to provide a digital signature which covers all or part of one or more HI-1 Objects, including other Approvals. Implementers should note that the ApprovalDigitalSignature field is **not** used to digitally sign an HI-1 Message or Action - this is done using the appropriate Message Security procedures given in clause 9.

For the avoidance of doubt, the following aspects of the ApprovalDigitalSignature are not in scope of the present document, and shall be defined by the relevant national profile:

- The circumstances and processes surrounding the use of digital signatures to indicate or assert approval of a given Object.
- Which parts of which HI-1 Objects have to be signed for a given HI-1 Object to be considered valid.
- Issues surrounding key management and distribution.

The ApprovalDigitalSignature contains one of the following structures.

Table E.4: Approval Digital Signature

Field	Format	Description
NationalDigitalSignature	Defined by the relevant national profile.	Nationally-defined digital signature details.

It is important that on a national basis appropriate measures are in place, either digitally or through other processes, to provide appropriate signature details. It is expected that future versions of the present document will include digital signature recommendation as defined by ETSI TC CYBER.

Annex F (normative): Dictionaries

F.1 Overview

The DictionaryEntry type is used to provide for fields that can be easily and unambiguously extended by national implementers without needing to change the underlying schema or the HI-1 message parsing and storing aspects of an implementation (e.g. a database).

This annex describes the following:

- The definition of the DictionaryValue type and associated dictionaries.
- Definitions, procedures and conventions concerning the definition and use of dictionaries.

F.2 DictionaryEntry type

The DictionaryEntry type is intended to represent a single string value chosen from an extensible enumerated list. It is defined as follows.

Table F.1: DictionaryEntry

Field	Format	Description
Owner	ShortString (see ETSI TS 103 280 [7]).	Name of the owner of the dictionary (see clause F.3.2).
Name	ShortString (see ETSI TS 103 280 [7]).	Name of the dictionary from which the value is chosen (see clause F.3.3).
Value	ShortString (see ETSI TS 103 280 [7]).	Value chosen from the dictionary.

A dictionary of DictionaryEntry values shall consist of the following definitions.

Table F.2: Required information when defining a dictionary

Field	Format	Description
Owner	ShortString (see ETSI TS 103 280 [7]).	Name of the owner of the dictionary (see clause F.3.2).
Name	ShortString (see ETSI TS 103 280 [7]).	Name of the dictionary from which the value is chosen (see clause F.3.3).
Value	ShortString (see ETSI TS 103 280 [7]).	A label which is unique within the dictionary, and assigned a meaning.
Meaning	LongString (see ETSI TS 103 280 [7]).	A human-readable definition of the meaning associated with the Value.

For more details on the definition and use of dictionaries, see clause F.3.

F.3 Definition and use of dictionaries

F.3.1 Overview

This clause defines the definition and use of dictionaries.

F.3.2 Owner

Each dictionary has a defined owner. The owner of a dictionary is responsible for the definition of the dictionary, as well as the maintenance and publication of the dictionary. All dictionaries shall contain at least the information specified in clause F.2.

A dictionary owner is specified by a string value. The following owners are defined by the present document:

- "ETSI": The dictionary is owned by ETSI, and defined in the present document.
- A valid ISO 3166 country code: The dictionary is owned and defined by the relevant national authority for the country specified by the country code.

F.3.3 Name

Each dictionary shall have a defined name which is unique within the owner of that dictionary. A name may be any valid ShortString.

F.3.4 Use of dictionaries

Any field which the present document defines as a DictionaryEntry shall either specify an ETSI dictionary of default values, or specify that the permissible values shall be given in a nationally-defined dictionary.

If an ETSI dictionary is specified, then each national profile may specify additional dictionaries that contain additional permissible types and values, as well as confirming or clarifying the handling of ETSI defined values. If an ETSI dictionary is not specified, then each national profile shall either specify a dictionary of permissible values, or state that the field shall not be used.

It is strongly discouraged to introduce ambiguity by duplicating ETSI-defined values in nationally-owned dictionaries. Should ETSI choose to adopt a value already defined in a nationally-owned dictionary, the owner is strongly encouraged to consider whether to retain the nationally-defined value.

A national profile shall not modify any dictionary that it is not the owner of by adding or removing values. However, it is permissible for a national profile to define the handling of ETSI-defined values.

F.3.5 Machine-readable dictionary definitions

Implementers are encouraged to allow Dictionary definitions to be easily updated to e.g. storing them in a database table, or ingesting them as a configuration file.

In order to facilitate this, an XML XSD schema is provided alongside the present document that defines a machine-readable format for Dictionary definitions ("ts_103120v010401p0.zip"). Additionally, the dictionary definitions given in the present document are supplied as an XML file which conforms to the dictionary specification ("ts_103120v010401p0.zip").

National profiles may specify additional dictionaries in additional XML files.

Annex G (normative): Drafting conventions for National Parameters

G.1 Overview

This clause gives normative drafting conventions and guidelines that shall be used when drafting National Parameters for use in the National Parameter extension points.

G.2 Drafting conventions

National profiles are encouraged to restrict the number of national extensions to a minimum, and use standard fields and/or extended dictionary types where possible (see annex F for more details on dictionaries).

A national profile shall specify whether a National Parameter definition exists for each of the extension points defined in the standard. An extension point can be identified in the following way:

- The element name begins with "National".
- The element is defined as being "abstract" in the schema.
- The abstract definition contains a single "CountryCode" field.

A National Parameter definition shall follow these drafting conventions:

- It shall be defined in a schema with a namespace specific to, and defined in, the relevant national profile.
- It shall be defined as an extension of the relevant base type via XSD's `xs:extension` mechanism.
- In instance XML documents, the "CountryCode" field shall be populated with the country code of the relevant national profile, to indicate the source of the extension.

Annex H (informative): Bibliography

- W3C Recommendation 10 June 2008: "XML Signature Syntax and Processing (Second Edition)".
- IETF RFC 2822: "Internet Message Format".
- W3C Working Group Note 11 April 2013: "XML Signature Best Practices".

Annex I (informative): Change Request history

Status of the present document Lawful Interception (LI); Interface for warrant information		
TC LI approval date	Version	Remarks
September 2015	1.1.1	First publication of the TS after approval by ETSI TC LI#40 Document prepared by the Rapporteur
February 2016	1.2.1	Included Change Requests agreed by ETSI TC LI#41: CR001, LI(16)P41013r1 (Cat C) Tasking Delivery IP Address and Port CR002, LI(16)P41019r1 (Cat A) Initial corrections to ETSI TS 103 120 CR003, LI(16)P41021r2 (Cat B) Addition of Task IsEmergency flag Document prepared by the Rapporteur
February 2019	1.3.1	Included Change Requests agreed by ETSI TC LI#50 CR004, LI(19)P50015r1 (Cat B) CR to support 3GPP 5G work Document prepared by the Rapporteur
October 2019	1.4.1	Included Change Requests agreed by ETSI TC LI#52 CR005, LI(19)P52032r1 (Cat B) Support for Lawful Disclosure in ETSI TS 103 120

History

Document history		
V1.1.1	January 2016	Publication
V1.2.1	March 2016	Publication
V1.3.1	May 2019	Publication
V1.4.1	December 2019	Publication