

# ETSI TS 102 929 V2.2.1 (2015-10)



TECHNICAL SPECIFICATION

**Speech and multimedia Transmission Quality (STQ);  
Procedures for the identification and selection of  
common modes of de-jitter buffers and echo cancellers**

---

Reference

RTS/STQ-238

---

Keywords

de-jitter buffer, QoS, quality

**ETSI**

650 Route des Lucioles  
F-06921 Sophia Antipolis Cedex - FRANCE

Tel.: +33 4 92 94 42 00 Fax: +33 4 93 65 47 16

Siret N° 348 623 562 00017 - NAF 742 C  
Association à but non lucratif enregistrée à la  
Sous-Préfecture de Grasse (06) N° 7803/88

---

**Important notice**

The present document can be downloaded from:  
<http://www.etsi.org/standards-search>

The present document may be made available in electronic versions and/or in print. The content of any electronic and/or print versions of the present document shall not be modified without the prior written authorization of ETSI. In case of any existing or perceived difference in contents between such versions and/or in print, the only prevailing document is the print of the Portable Document Format (PDF) version kept on a specific network drive within ETSI Secretariat.

Users of the present document should be aware that the document may be subject to revision or change of status. Information on the current status of this and other ETSI documents is available at  
<http://portal.etsi.org/tb/status/status.asp>

If you find errors in the present document, please send your comment to one of the following services:  
<https://portal.etsi.org/People/CommitteeSupportStaff.aspx>

---

**Copyright Notification**

No part may be reproduced or utilized in any form or by any means, electronic or mechanical, including photocopying and microfilm except as authorized by written permission of ETSI.

The content of the PDF version shall not be modified without the written authorization of ETSI.  
The copyright and the foregoing restriction extend to reproduction in all media.

© European Telecommunications Standards Institute 2015.  
All rights reserved.

**DECT™**, **PLUGTESTS™**, **UMTS™** and the ETSI logo are Trade Marks of ETSI registered for the benefit of its Members.  
**3GPP™** and **LTE™** are Trade Marks of ETSI registered for the benefit of its Members and of the 3GPP Organizational Partners.  
**GSM®** and the GSM logo are Trade Marks registered and owned by the GSM Association.

# Contents

Intellectual Property Rights .....	5
Foreword.....	5
Modal verbs terminology.....	5
Introduction .....	5
1 Scope .....	6
2 References .....	7
2.1 Normative references .....	7
2.2 Informative references.....	7
3 Definitions and abbreviations.....	9
3.1 Definitions .....	9
3.2 Abbreviations .....	10
4 Characteristics of de-jitter buffers .....	11
4.1 De-Jitter buffers.....	11
4.2 Purpose, operation and environment .....	11
4.3 External enabling of fixed de-jitter buffers .....	11
5 Characteristics of VBD-mode switching of de-jitter buffers.....	12
5.1 General .....	12
5.2 Detector characteristics .....	13
5.2.1 Detector characteristics for frequency range of 2 100 Hz $\pm$ 21 Hz.....	13
5.2.2 Detector characteristics for dual-frequency tones 1 375 Hz + 2 002 Hz and 1 529 Hz + 2 225 Hz (Recommendation ITU-T V.8bis).....	13
5.2.3 Detector characteristics for frequencies 980 Hz, 1 180 Hz, 1 650 Hz and 1 850 Hz (V.21).....	14
5.2.4 Detector characteristics for 2 100 Hz amplitude-modulated by a sinewave at 15 Hz, 2 100 Hz amplitude-modulated by a sinewave at 15 Hz with phase reversals, 1 300 Hz and 1 100 Hz (V.8).....	14
5.2.5 Detector characteristics for V.22 .....	15
5.2.6 Detector characteristics for 2 100 Hz with phase reversals (V.25).....	16
5.2.7 Detector characteristics for Recommendation ITU-T V.32/V.32bis .....	19
5.2.8 Detector characteristics for Recommendation ITU-T T.30 .....	19
5.2.9 Noise tolerance .....	20
5.2.10 Operate time.....	20
5.2.11 False operation due to speech signals .....	20
5.2.12 Release time.....	20
5.2.13 Other considerations .....	20
6 Activation of de-jitter buffer for VBD .....	20
7 Activation of de-jitter buffer for 64 kbit/s bit sequence (UDI) .....	25
8 Requirements for values of de-jitter buffers.....	26
8.1 Fixed de-jitter buffers .....	26
8.2 Adaptive de-jitter buffers .....	26
8.3 Activation procedure into the fixed mode .....	26
8.4 Transition from VBD to Voice mode (Recommendation ITU-T V.152) .....	27
8.5 Handling of De-jitter buffer in case of lost or late packets.....	28
9 Echo canceller .....	29
9.1 Introduction .....	29
9.2 Characteristics of an echo canceller tone disabler (Recommendation ITU-T G.168).....	29
9.2.1 General.....	29
9.2.2 Detector characteristics.....	29
9.2.3 Phase reversal detection.....	30
9.2.4 Guard band characteristics.....	30
9.2.5 Noise tolerance .....	31
9.2.6 Holding-band characteristics .....	31
9.2.7 Operate time.....	31

9.2.8	False operation due to speech currents .....	32
9.2.9	False operation due to data signals .....	32
9.2.10	Release time.....	32
9.2.11	Other considerations .....	32
<b>Annex A (normative): De-jitter buffer Facsimile tests .....</b>		<b>33</b>
A.1	Measurement method .....	33
<b>Annex B (normative): Echo canceller Tests.....</b>		<b>62</b>
B.1	Introduction .....	62
B.1.1	Signals used.....	62
B.1.2	Preparatory measurements.....	62
B.2	Tests with echo simulation at Interface B .....	63
B.2.1	Introduction .....	63
B.2.2	Tests with test signals based on Composite Source Signal (CSS).....	64
B.2.2.1	Answer tones + C16.....	64
B.2.2.2	Answer tones + first fax frame + C16.....	65
B.2.2.3	Tests with test signals based on the Use of the CI call signal and exchange of CM/JM menu signals + C16 .....	66
B.2.2.4	Tests with test signals based on DTMF .....	67
B.2.2.4.1	Answer tones + D16.....	67
B.2.2.5	Tests with test signals based on the Use of the CI call signal and exchange of CM/JM menu signals + D16 .....	68
B.3	Tests with echo simulation at Interface A .....	69
B.3.1	Introduction .....	69
B.3.2	Tests with test signals based on CSS.....	70
B.3.2.1	Answer tones + C16.....	70
B.3.2.2	Answer tones + first fax frame + C16.....	71
B.3.2.3	Tests with test signals based on the Use of the CI call signal and exchange of CM/JM menu signals + C16 .....	72
B.3.2.4	Tests with test signals based on DTMF .....	73
B.3.2.4.1	Answer tones + D16.....	73
B.3.2.5	Tests with test signals based on the Use of the CI call signal and exchange of CM/JM menu signals + D16 .....	74
B.4	Tests with test signals based on the data rate change between V.34 and V.17 Fax Terminals .....	74
<b>Annex C (informative): Features of V.17 Fax and V.34 Fax .....</b>		<b>76</b>
C.1	Features of V.17 Fax (V.17 Fax Modem) .....	76
C.2	V.34 High-Speed Fax .....	76
C.2.1	Features .....	76
C.2.2	The Recommendation ITU-T V.34 Fax Standard .....	76
C.3	The V.34 Fax Connection and Session .....	77
C.4	ECM as a Mandatory Feature.....	78
History	.....	79

---

## Intellectual Property Rights

IPRs essential or potentially essential to the present document may have been declared to ETSI. The information pertaining to these essential IPRs, if any, is publicly available for **ETSI members and non-members**, and can be found in ETSI SR 000 314: *"Intellectual Property Rights (IPRs); Essential, or potentially Essential, IPRs notified to ETSI in respect of ETSI standards"*, which is available from the ETSI Secretariat. Latest updates are available on the ETSI Web server (<http://ipr.etsi.org>).

Pursuant to the ETSI IPR Policy, no investigation, including IPR searches, has been carried out by ETSI. No guarantee can be given as to the existence of other IPRs not referenced in ETSI SR 000 314 (or the updates on the ETSI Web server) which are, or may be, or may become, essential to the present document.

---

## Foreword

This Technical Specification (TS) has been produced by ETSI Technical Committee Speech and multimedia Transmission Quality (STQ).

---

## Modal verbs terminology

In the present document "**shall**", "**shall not**", "**should**", "**should not**", "**may**", "**need not**", "**will**", "**will not**", "**can**" and "**cannot**" are to be interpreted as described in clause 3.2 of the [ETSI Drafting Rules](#) (Verbal forms for the expression of provisions).

"**must**" and "**must not**" are **NOT** allowed in ETSI deliverables except when used in direct citation.

---

## Introduction

The present document describes the characteristics of a de-jitter buffer, including the requirement for in-band tone activating and other control mechanisms.

---

# 1 Scope

De-jitter buffers and echo cancellers have a major effect on voice and data transmission quality in telecommunication networks. They affect the three service categories of PSTN/ISDN voice, voiceband data (due to PSTN modem and fax calls), and ISDN circuit mode data. Since the requirements for the settings of de-jitter buffers differ for different services, the present document describes the activation and mode switching procedures of de-jitter buffers and echo cancellers, including the requirement for in-band tone activating and other control mechanisms.

It is assumed that the clock accuracy of all elements involved is sufficiently high for application of the present document.

The scope of the present document is considering de-jitter buffer usage in circuit-to-IP media gateways, such as residential, access or trunking gateways in context of NGN/IMS.

The notion of circuit relates to a PSTN analog line or an ISDN 1x64 bearer channel.

The current version of the present document contains additional de-Jitter Buffer requirements for the transmission of V.152, Echo Canceller Tests and de-Jitter Buffer Tests.

The requirements for Echo Cancellers and de-Jitter Buffers in for speech transmission are out of scope in the present document. These requirements are covered in ETSI ES 202 718 [i.27].

The present document is:

- a) applicable:
  - a1) to circuit-to-IP media gateways and communication services with a gateway interworking function operating at the level of a synchronous byte-stream, such as:
    - service "voice-over-IP" (VoIP) without or with silence suppression;
    - service "voiceband data-over-IP" (VBDoIP); and
    - service "circuit-mode data-over-IP" (CMDoIP);
  - a2) to IP-to-IP media gateways for dedicated interworking services between two IP domains, such as:
    - service "IPDV reduction between two IP domains" with different Grade of Service (GoS) as e.g. described in [i.22];
    - service "RTP IPDV reduction between two RTP domains", which may be subject of an "RTP transport translator" topology (see [i.23] and [i.24]);

but IP-to-IP media gateways are basically out of scope of the present document due to its focus on circuit-to-IP gateway types;

and is:

- b) not applicable, because de-jitter buffers are not required:
  - b1) to circuit-to-IP media gateways and communication services with a gateway interworking function operating at the level of individual packets as atomic units (i.e. an asynchronous packet-stream), such as:
    - service "facsimile-over-IP" (FoIP) according to [i.7];
    - service "text-over-IP" (ToIP) according to [i.25]; and
    - service "data-over-IP" (MoIP) according to [i.26];
  - b2) to IP-to-IP media gateways in general.

---

## 2 References

### 2.1 Normative references

References are either specific (identified by date of publication and/or edition number or version number) or non-specific. For specific references, only the cited version applies. For non-specific references, the latest version of the reference document (including any amendments) applies.

Referenced documents which are not found to be publicly available in the expected location might be found at <http://docbox.etsi.org/Reference>.

NOTE: While any hyperlinks included in this clause were valid at the time of publication, ETSI cannot guarantee their long term validity.

The following referenced documents are necessary for the application of the present document.

- [1] Recommendation ITU-T V.8 (2000): "Procedures for starting sessions of data transmission over the public switched telephone network".
- [2] Recommendation ITU-T V.8bis (2000): "Procedures for the identification and selection of common modes of operation between data circuit-terminating equipments (DCEs) and between data terminal equipments (DTEs) over the public switched telephone network and on leased point to-point telephone-type circuits".
- [3] Recommendation ITU-T G.168: "Digital network echo cancellers".
- [4] Recommendation ITU-T V.21 (1988): "300 bits per second duplex modem standardized for use in the general switched telephone network".
- [5] Recommendation ITU-T V.22 (1988): "1200 bits per second duplex modem standardized for use in the general switched telephone network and on point-to-point 2-wire leased telephone-type circuits".
- [6] Recommendation ITU-T V.25 (1996): "Automatic answering equipment and general procedures for automatic calling equipment on the general switched telephone network including procedures for disabling of echo control devices for both manually and automatically established calls".
- [7] Recommendation ITU-T V.32 (1993): "A family of 2-wire, duplex modems operating at data signalling rates of up to 9600 bit/s for use on the general switched telephone network and on leased telephone-type circuits".
- [8] Recommendation ITU-T V.32bis (1991): "A duplex modem operating at data signalling rates of up to 14 400 bit/s for use on the general switched telephone network and on leased point-to-point 2-wire telephone-type circuits".
- [9] Recommendation ITU-T V.152 (2010): "Procedures for supporting voiceband data over IP Networks".

### 2.2 Informative references

References are either specific (identified by date of publication and/or edition number or version number) or non-specific. For specific references, only the cited version applies. For non-specific references, the latest version of the reference document (including any amendments) applies.

NOTE: While any hyperlinks included in this clause were valid at the time of publication, ETSI cannot guarantee their long term validity.

The following referenced documents are not necessary for the application of the present document but they assist the user with regard to a particular subject area.

- [i.1] Recommendation ITU-T G.164: "Echo Suppressors".
- [i.2] Recommendation ITU-T G.165: "Echo Cancellers".

- [i.3] Recommendation ITU-T V.2 (1988): "Power levels for data transmission over telephone lines".
- [i.4] Void.
- [i.5] Recommendation ITU-T G.131 (1996): "Control of talker echo".
- [i.6] Recommendation ITU-T Q.115.1 (1999): "Logic for the control of echo control devices/functions".
- [i.7] Recommendation ITU-T T.38 (2010): "Procedures for real-time Group 3 facsimile communication over IP networks".
- [i.8] Introduction to V.34 High-Speed Fax.

NOTE: Website: <http://www.gaoresearch.com/V34Fax/V34Fax.php>, latest access 4 July 2012.

- [i.9] Recommendation ITU-T V.34 (1998): "A modem operating at data signalling rates of up to 33 600 bit/s for use on the general switched telephone network and on leased point-to-point 2-wire telephone-type circuits".
- [i.10] Recommendation ITU-T T.30: "Procedures for document facsimile transmission in the general switched telephone network".
- [i.11] Recommendation ITU-T V.150.1: "Modem-over-IP networks: Procedures for the end-to-end connection of V-series DCEs".
- [i.12] Recommendation ITU-T V.18: "Procedures for starting sessions of data transmission over the public switched telephone network".
- [i.13] Recommendation ITU-T G.711: "Pulse code modulation (PCM) of voice frequencies".
- [i.14] Recommendation ITU-T G.1020 (11/2003): "Performance parameter definitions for quality of speech and other voiceband applications utilizing IP networks".
- [i.15] Recommendation ITU-T T.4: "Standardization of Group 3 facsimile terminals for document transmission".
- [i.16] Recommendation ITU-T T.6: "Facsimile coding schemes and coding control functions for Group 4 facsimile apparatus".
- [i.17] ETSI TR 183 072 (V3.1.1): "Telecommunications and Internet converged Services and Protocols for Advanced Networking (TISPAN); Emulation Services for PSTN Modem Calls".
- [i.18] Recommendation G.161.1: "Do-no-harm testing".
- [i.19] Recommendation ITU-T I.231.1: "Circuit-mode bearer service categories : Circuit-mode 64 kbit/s unrestricted, 8 kHz structured bearer service".
- [i.20] IETF RFC 4040: "RTP Payload Format for a 64 kbit/s Transparent Call".
- [i.21] Recommendation ITU-T Q.931: "ISDN user-network interface layer 3 specification for basic call control".
- [i.22] Recommendation ITU-T G.799.3: "Signal processing functionality and performance of an IP-to-IP voice gateway optimised for the transport of voice and voiceband data".
- [i.23] IETF RFC 5117: "RTP Topologies".
- [i.24] Recommendation ITU-T H.248.88: "Gateway control protocol: RTP topology dependent RTCP handling by ITU-T H.248 media gateways with IP terminations".
- [i.25] Recommendation ITU-T V.151: "Procedures for the end-to-end connection of analogue PSTN text telephones over an IP network utilizing text relay".
- [i.26] Recommendation Recommendation ITU-T V.150.1: "Modem-over-IP networks: Procedures for the end-to-end connection of V-series DCEs".



[i.27] ETSI ES 202 718: "Speech and multimedia Transmission Quality (STQ); Transmission Requirements for IP-based Narrowband and Wideband Home Gateways and Other Media Gateways from a QoS Perspective as Perceived by the User".

## 3 Definitions and abbreviations

### 3.1 Definitions

For the purposes of the present document, the following terms and definitions apply:

**acoustic echo:** acoustic echoes consist of reflected signals caused by acoustic environments

NOTE: In these acoustic environments, an echo path is introduced by the acoustic path from the loudspeaker or earpiece to the microphone, e.g. echo created from hands-free speakerphones [3].

**de-jitter buffer [i.14]:** buffer designed to remove the delay variation (i.e. jitter) in packet arrival times

NOTE: Data is put into the de-jitter buffer at a variable rate (i.e. whenever they are received from the network), and taken out at a constant rate.

**Echo Canceller (EC):** voice-operated device placed in the 4-wire portion of a circuit and used for reducing the cancelled end echo present on the send path by subtracting an estimation of that echo from the cancelled end echo [3]

**G3 facsimile equipment (G3FE) [i.7]:** G3FE refers to any entity which presents a communications interface conforming to [i.10], [i.15] and optionally [i.16]. A G3FE may be a traditional G3 facsimile machine, an application with an ITU-T T.30 [i.10] protocol engine, or any of the other possibilities mentioned in the network model for IP facsimile.

**Non-Linear Processor (NLP):** device having a defined suppression threshold level and in which:

- a) signals having a level detected as being below the threshold are suppressed; and
- b) signals having a level detected as being above the threshold are passed although the signal may be distorted

NOTE: The present document assumes an echo canceller is equipped with an NLP function that can be enabled or disabled when performing the tests defined in the present document. An NLP function can be enabled or disabled by the user (for the purpose of performing a particular test), or may also be disabled upon detection of an appropriate disabling tone (e.g. 2 100 Hz) [3].

**pseudo-VBDoIP emulation service:** XoIP emulation service, trying to support voiceband data in *audio mode* (see clause 3.2.1 of [9]), also known as non-V.152 VBDoIP service

**PSTN modem call [i.17]:** voiceband data call originating/terminating in a PSTN domain

NOTE: The term voiceband data (VBD) is an umbrella term for all kind of teleservices which using a "data-oriented transport" in the frequency band of the narrowband voice spectrum (which is a 3,1-kHz-band). The data-oriented transport is realized by modem protocols (definition as in clause 3.13 of Recommendation ITU-T V.152 [9]), as defined e.g. within the ITU-T V.x-series of Recommendations. Teleservices may be categorized into three major applications areas: facsimile, text-based communication and general data services.

**T.38/G3 [i.7]:** ITU-T T.38/G3 refers to an ITU-T T.38 endpoint that supports G3FE, but excludes the ITU-T T.30/V.34 procedures.

**T.38/V.34G3 [i.7]:** ITU-T T.38/ITU-T V.34G3 [i.8] refers to an ITU-T T.38 endpoint that supports G3FE and includes the ITU-T T.30/V.34 half-duplex procedures.

**VBD gateway [9]:** media gateway that is compliant with Recommendation ITU-T V.152 [9]

**VBDoIP emulation service:** XoIP emulation service compliant to Recommendation ITU-T V.152 [9]

**voiceband data mode [9]:** transport of voiceband data over a voice channel of a packet network with the encoding appropriate for modem signals as defined in section 6 of Recommendation ITU-T V.152 [9]

**XoIP emulation service (for PSTN modem calls) [i.17]:** emulation service in IP networks, based on appropriated gateway technologies for interworking voiceband data information between the PSTN and IP networks

NOTE: Example emulation services for the three main VBD application areas, which may be summarized as (by using notation "application/transport"):

- Facsimile/modem: Gateway technologies for PSTN-to-IP interworking see e.g. Recommendation ITU-T V.152 [9] for pass-through mode and Recommendation ITU-T T.38 [i.7] as packet-relay mode;
- Text/modem: Gateway technologies for PSTN-to-IP interworking see e.g. Recommendation ITU-T V.152 [9] for pass-through mode and Recommendation ITU-T V.151 [i.25] as packet-relay mode; and
- Data/modem: Gateway technologies for PSTN-to-IP interworking see e.g. Recommendation ITU-T V.152 [9] for pass-through mode and Recommendation ITU-T V.150.1 [i.11] as packet-relay mode.

## 3.2 Abbreviations

For the purposes of the present document, the following abbreviations apply:

ANM	Answer Message
ANS	Answer Tone
ATA	Analog Terminal Adapter
CED	Called station identification tone
CM	Call Menu signal
CM/JM	Call Menu signal/Joint Menu signal
CMD	Circuit-Mode Data
CNG	Calling Tone
CSS	Composite Source Signal
CT	Calling Tone
DCE	Data Communication Equipment
DJB	De Jitter Buffer
DTMF	Dual-Tone Multi-Frequency signaling
EC	Echo Canceller
ECM	Error Correction Mode
ERL	Echo Return Loss
ERLE	Echo Return Loss Enhancement
GSTN	General Switched Telephone Network
IAD	Integrated Access Device
IP	Internet Protocol
IPDV	IP Delay Variation
ISDN	Integrated Services Digital Network
ISUP	ISDN User Part
ITU-T	International Telecommunication Union - Telecommunication Standardization Sector
JB	de-Jitter Buffer
JBD	de-Jitter Buffer Delay
JBS	de-Jitter Buffer Size
JM	Joint Menu signal
MGC	Media Gateway Controller
MGW	Media Gateway
MSAN	Multi Service Access Nodes
NGN	New Generation Network
NLP	Non-Linear Processor
NNI	Network Network Interface
PCM	Pulse Code Modulation
PLC	Packet Loss Concealment
PSTN	Public Switched Telephone Network
QAM	Quadrature Amplitude Modulation
RCV	Received
RTP	Real Time Protocol
SDP	Session Description Protocol
SIP	Session Initiation Protocol

SSND	Signal - Send
TDM	Time Division Multiplexing
UDI	Unrestricted Digital Information
UNI	User Network Interface
VBD	VoiceBand Data

## 4 Characteristics of de-jitter buffers

### 4.1 De-Jitter buffers

The present document describes the activation procedures of a de-jitter buffer, including the requirement for in-band tone activating and other control mechanisms. The de-jitter buffers are assumed to be dynamic de-jitter buffers and fixed de-jitter buffers. Fixed de-jitter buffers shall be provided for fax and voiceband data and 64 kbit/s bit sequence (UDI).

A de-jitter buffer is designed to remove the effects of jitter from the decoded voice stream, buffering each arriving packet for a short interval before playing it out synchronously. A **fixed de-jitter buffer** maintains a constant size whereas an **adaptive de-jitter buffer** has the capability of adjusting its size dynamically in order to optimize the delay/discard trade-off. The disadvantage of **adaptive de-jitter buffer** is that a part of the jitter budget is transferred to the user. While the human perception of audio delay variation is low, modem and fax applications are extremely sensitive to delay variation in the audio path. For this reason adaptive de-jitter buffer are not applicable for fax and modem transmission. Fixed de-jitter buffers try to maintain a constant End-to-End audio delay.

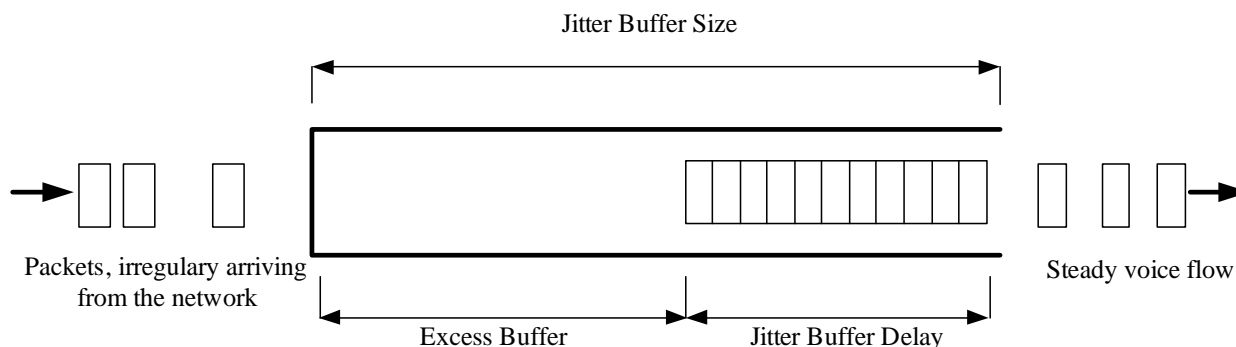

**Figure 1: De-jitter buffer Size and Delay**

De-jitter buffer Size (JBS): The maximum amount of time packets can stay in the buffer.

De-jitter buffer Delay (JBD): The de-jitter buffer delay is also called de-jitter delay, holding time or play-out delay. It corresponds to the time packets stay in the buffer, which is less than the de-jitter buffer size. The time of departure of each packet is determined by reading out the timestamp information provided by RTP.

### 4.2 Purpose, operation and environment

For proper operation for VBD-services, De-jitter buffers have the following fundamental requirements:

- 1) fast and correct switching between dynamic and fix de-jitter buffer mode;
- 2) proper operation during facsimile and data transmissions.

For proper operation of speech services in good quality, false detection of tones (e.g. from answering machines, call centers or speech) has to be minimized.

NOTE: It may be necessary to make a balancing between quality requirements of VBD and speech services.

### 4.3 External enabling of fixed de-jitter buffers

The fixed de-jitter buffer for 64 kbit/s bit sequence (UDI) and V.152 VBD shall be activated directly by signaling.

---

## 5 Characteristics of VBD-mode switching of de-jitter buffers

### 5.1 General

The de-jitter buffer covered by the present document should be equipped with a tone detector that conforms to this clause.

- The change of the de-jitter buffer to VBD-mode should be based on the following signals (mostly taken out of Recommendation ITU-T V.152 [9]) For Facsimile applications:
  - CED as per Recommendation ITU-T T.30 [i.10]
  - ANSam as per Recommendation ITU-T V.8 [1]
  - Preamble as per Recommendation ITU-T T.30 [i.10], section 5.3.1
  - CNG as per Recommendation ITU-T T.30 [i.10]
- For Modem applications:
  - ANS as per Recommendation ITU-T V.8 [1]
  - ANSam as per Recommendation ITU-T V.8 [1]
  - /ANS as per Recommendation ITU-T V.25 [6]
  - 2 225 Hz answer tone as per Recommendation ITU-T V.150.1 [i.11], appendix VI
  - Unscrambled binary ones signal as per Recommendation ITU-T V.22 [5]
  - CI signals that precede ANSam, as per Recommendations ITU-T V.8 [1] and V.21 [4]
  - Dual-frequency tones (1 375 Hz + 2 002 Hz and 1 529 Hz + 2 225 Hz) as per Recommendation ITU-T V.8bis [2]
- For Text Telephony applications:
  - ANS as per Recommendation ITU-T V.8 [1]
  - ANSam as per Recommendation ITU-T V.8 [1]
  - Text telephone signals as defined by Recommendation ITU-T V.18 [i.12], section 5.1.1
  - CI signals that precede ANSam, as per Recommendation ITU-T V.8 [1]
  - CT (Calling Tone) signals that precede ANS, as per Recommendation ITU-T V.25 [6]
  - Initiating Segment 1 dual tones (1 375 Hz & 2 002 Hz) as per Recommendation ITU-T V.8bis [2]

## 5.2 Detector characteristics

### 5.2.1 Detector characteristics for frequency range of $2\,100\text{ Hz} \pm 21\text{ Hz}$

The tone detector shall detect a tone in the frequency range of  $2\,100\text{ Hz} \pm 21\text{ Hz}$  (see Recommendation ITU-T V.21 [4]). The detection channel bandwidth should be chosen wide enough to encompass this tone (and possibly other tones used within national networks). At the same time, the detection channel bandwidth should be such that, in conjunction with guard action and timing, adequate protection is provided against false operation of the detector by speech signals. The detector channel sensitivity (threshold level) should be such that the detector will operate on the lowest expected power of the tone. The band characteristics shown in figure 2 will permit changing the de-jitter buffer behaviour by the  $2\,100\text{ Hz}$  tone as well as others used in North America. The figure indicates that in the frequency band  $2\,079\text{ Hz}$  to  $2\,121\text{ Hz}$  detection **shall** be possible whilst in the band  $1\,900\text{ Hz}$  to  $2\,350\text{ Hz}$  detection **may** be possible. Providing that only the recommended  $2\,100\text{ Hz}$  tone is used internationally, interference with signalling equipment will be avoided. The dynamic range of the detector should be consistent with the input levels as specified in Recommendation ITU-T V.2 [i.3] with allowances for variation introduced by the public switched telephone network.

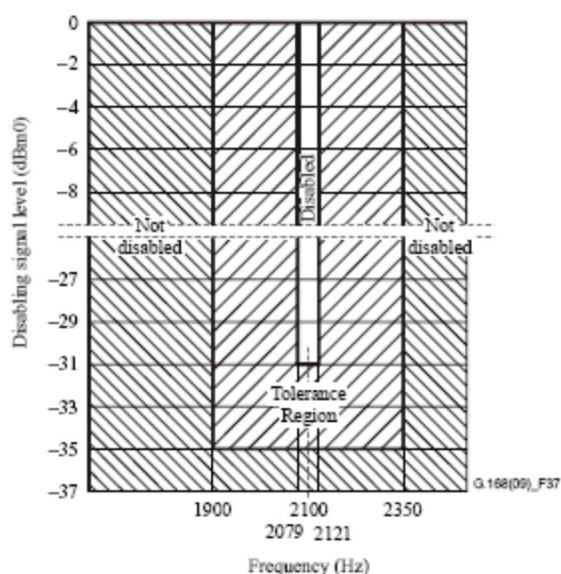

Figure 2: Required band characteristics

### 5.2.2 Detector characteristics for dual-frequency tones $1\,375\text{ Hz} + 2\,002\text{ Hz}$ and $1\,529\text{ Hz} + 2\,225\text{ Hz}$ (Recommendation ITU-T V.8bis)

The tone detector shall detect two tone segments. The first segment consists of a dual-frequency tone held for 400 ms. The specific frequencies  $1\,375\text{ Hz} + 2\,002\text{ Hz}$  are used from the initiator, the specific frequencies  $1\,529\text{ Hz} + 2\,225\text{ Hz}$  from the responder in a transaction. When using the telephone-event payload, the V8bISeg and V8bRSeg events in table 1 represent the first segment of any V.8bis signal in the initiating and responding case, respectively.

Table 1: Events for V.8bis signals

Signal	Frequency
V8bISeg	$1\,375\text{ Hz} + 2\,002\text{ Hz}$
V8bRSeg	$1\,529\text{ Hz} + 2\,225\text{ Hz}$

The tolerance of the frequency of all tones is to be  $\pm 250\text{ ppm}$  of the nominal value.

The tolerance of the duration of the tone segments shall be  $\pm 2\%$ .

The detection channel bandwidth should be chosen wide enough to encompass this tones (and possibly other tones used within national networks). At the same time, the detection channel bandwidth should be such that, in conjunction with guard action and timing, adequate protection is provided against false operation of the detector by speech signals. The detector channel sensitivity (threshold level) should be such that the detector will operate on the lowest expected power of the tone.

### 5.2.3 Detector characteristics for frequencies 980 Hz, 1 180 Hz, 1 650 Hz and 1 850 Hz (V.21)

The tone detector shall detect the frequencies 980 Hz for '1' (mark) and 1 180 Hz for '0' (space) (low channel uses) and the frequencies 1 650 Hz for '1' and 1 850 Hz for '0' (high channel uses). The frequency deviation is  $\pm 100$  Hz.

The detection channel bandwidth should be chosen wide enough to encompass this tones (and possibly other tones used within national networks). At the same time, the detection channel bandwidth should be such that, in conjunction with guard action and timing, adequate protection is provided against false operation of the detector by speech signals. The detector channel sensitivity (threshold level) should be such that the detector will operate on the lowest expected power of the tone.

**Table 2: Events for V.21 Signals**

Signal	Frequency (Hz)
V.21 channel 1, '0' bit	1 180
V.21 channel 1, '1' bit	980
V.21 channel 2, '0' bit	1 850
V.21 channel 2, '1' bit	1 650

### 5.2.4 Detector characteristics for 2 100 Hz amplitude-modulated by a sinewave at 15 Hz, 2 100 Hz amplitude-modulated by a sinewave at 15 Hz with phase reversals, 1 300 Hz and 1 100 Hz (V.8)

To activate the De-jitter buffer at calling end respectively called end for procedures according to Recommendation ITU-T V.8 [1], the tone detector shall detect frequencies described in table 3.

**Table 3: Events for V.8 Signals**

Signal	Frequency
ANSam	2 100 Hz amplitude-modulated by a sinewave at 15 Hz
/ANSam	2 100 Hz amplitude-modulated by a sinewave at 15 Hz with phase reversals at an interval of $450 \pm 25$ ms
CI	(V.21 bits) (see note)
CT	1 300 Hz
CNG	1 100 Hz

NOTE: CI is transmitted from the calling DCE with a regular ON/OFF cadence. The ON periods shall be not less than 3 periods of the CI sequence, and not greater than 2 s in duration; the OFF periods shall be not less than 0,4 s and not greater than 2 s in duration.  
A CI sequence consists of 10 ONEs followed by 10 synchronization bits and the call function octet.

To initiate a session of data transmission on the PSTN according Recommendation ITU-T V.8 [1] a DCE transmits either CI, CT, CNG or no signal. Signal CI is a V.8 alternative to call tone CT, and is coded to indicate a call function. The term "call signal" is used hereinafter to refer to CI, CT or CNG.

Modified answer tone ANSam consists of a sinewave signal at  $2\,100 \pm 1$  Hz with phase reversals at an interval of  $450 \pm 25$  ms, amplitude-modulated by a sinewave at  $15 \pm 0,1$  Hz. The modulated envelope shall range in amplitude between  $(0,8 \pm 0,01)$  and  $(1,2 \pm 0,01)$  times its average amplitude.

The average transmitted power shall be in accordance with Recommendation ITU-T V.2 [i.3].

The average power outside the band  $2\ 100 \pm 200$  Hz produced by using an approximation to the 15 Hz sinewave envelope is at least 24 dB below the average power within that band.

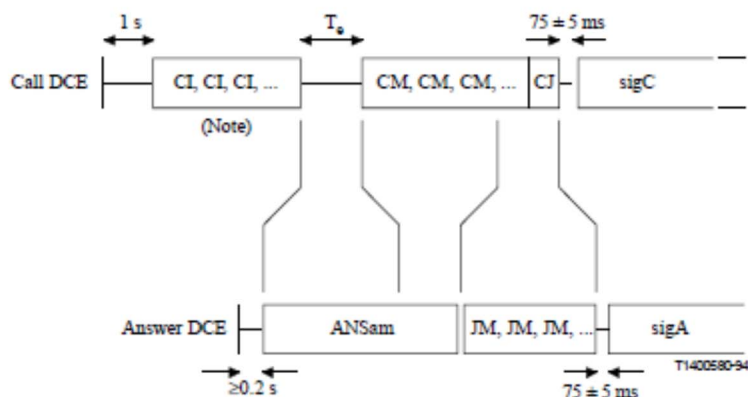

**Figure 3: Use of the CI call signal and exchange of CM/JM menu signals  
(Figure 1 from Recommendation ITU-T V.8 [1])**

The detection channel bandwidth should be chosen wide enough to encompass this tones (and possibly other tones used within national networks). At the same time, the detection channel bandwidth should be such that, in conjunction with guard action and timing, adequate protection is provided against false operation of the detector by speech signals. The detector channel sensitivity (threshold level) should be such that the detector will operate on the lowest expected power of the tone.

### 5.2.5 Detector characteristics for V.22

To activate the De-jitter buffer at calling end respectively called end for procedures according to Recommendation ITU-T V.22 [5], the detector shall detect unscrambled binary 1 for  $155 \pm 50$  ms from the calling terminal and Recommendation ITU-T V.25 [6] answer sequence from the called terminal.

**Table 4: Events for V.22/V.25 answer sequence**

Signal	Frequency
Answer tone (ANS)	2 100 Hz
unscrambled binary 1 for $155 \pm 50$ ms from the calling terminal	

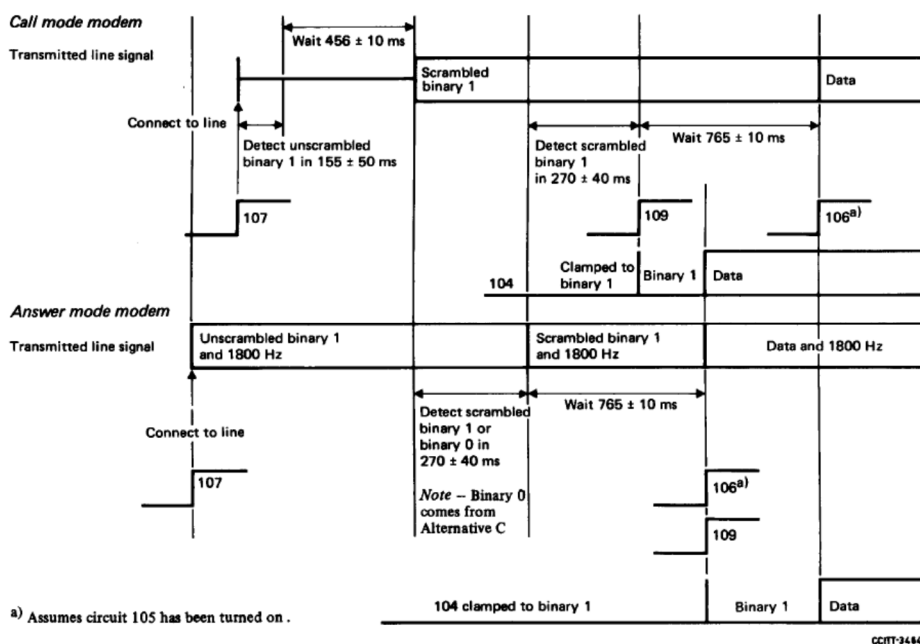
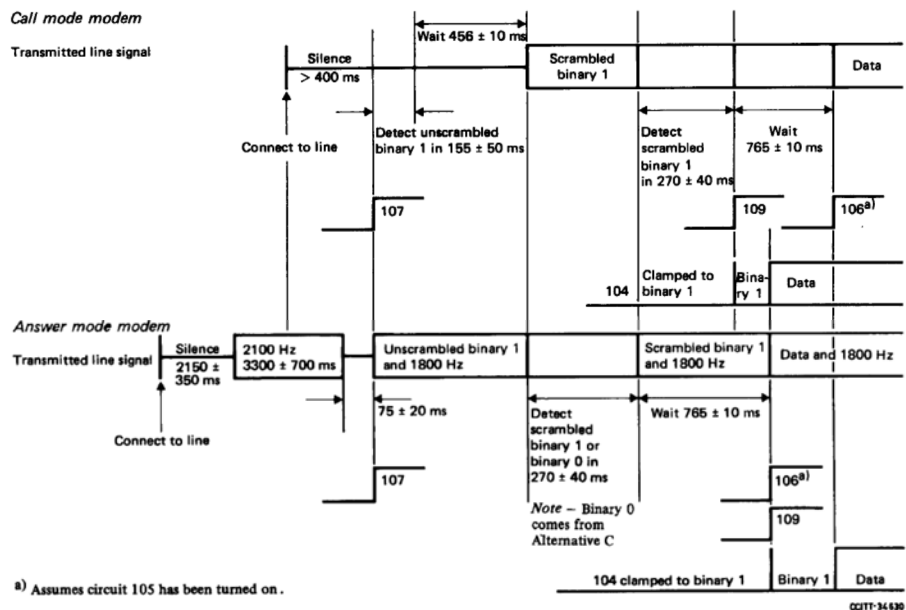

Figure 4: Handshake sequence for Alternatives A and B (with V.25 auto-answering)

### 5.2.6 Detector characteristics for 2 100 Hz with phase reversals (V.25)

Recommendation ITU-T V.25 [6] specifies the exchange of two tone signals: CT and ANS.

To activate the De-jitter buffer at calling end respectively called end for procedures according to Recommendation ITU-T V.25 [6], the tone detector shall detect frequencies described in table 5.



Table 5: Events for V.25 Signals

Signal	Frequency
Answer tone (ANS)	2 100 Hz
/ANS	2 100 Hz with phase reversals at an interval of $450 \pm 25$ ms
CT	1 300 Hz

The calling tone (CT) tone is transmitted from the calling end. This may be 1 300 Hz or any tone corresponding to binary 1 of the DCE. The calling tone and calling station response should not contain power in the band  $2\ 100 \pm 250$  Hz. The power levels of the signals specified in the present document shall conform to the levels specified in Recommendation ITU-T V.2 [i.3].

Calling Tone (CT) consists of a series of interrupted bursts of 1 300-Hz tone, on for a duration of not less than 0,5 s and not more than 0,7 s and off for a duration of not less than 1,5 s and not more than 2,0 s.

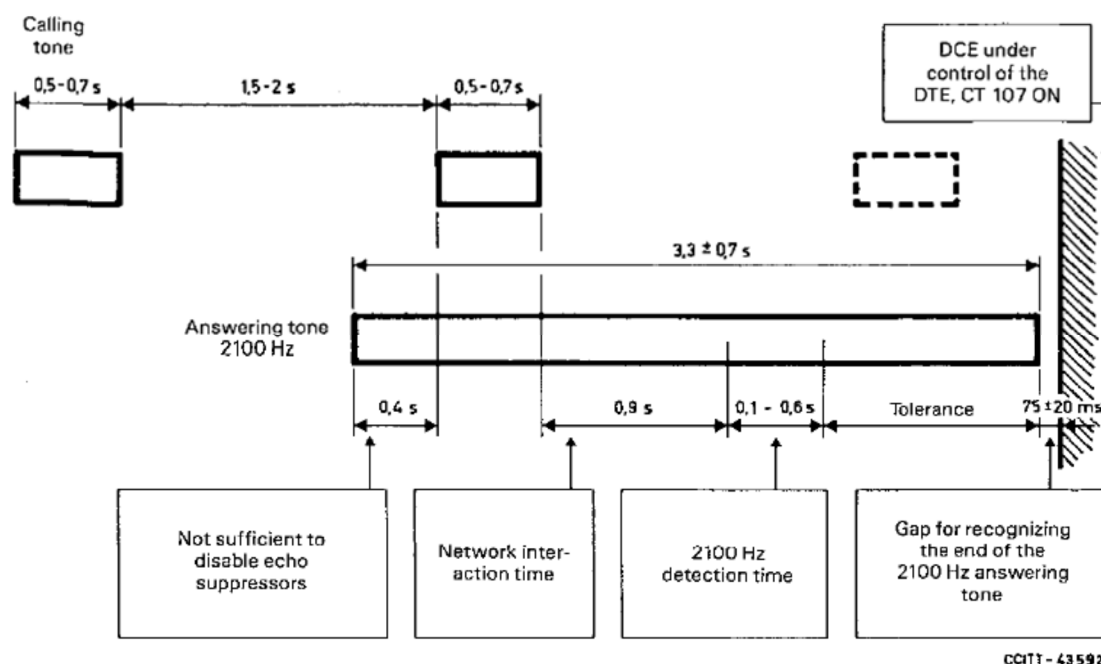

Figure 5: Timing of line signals

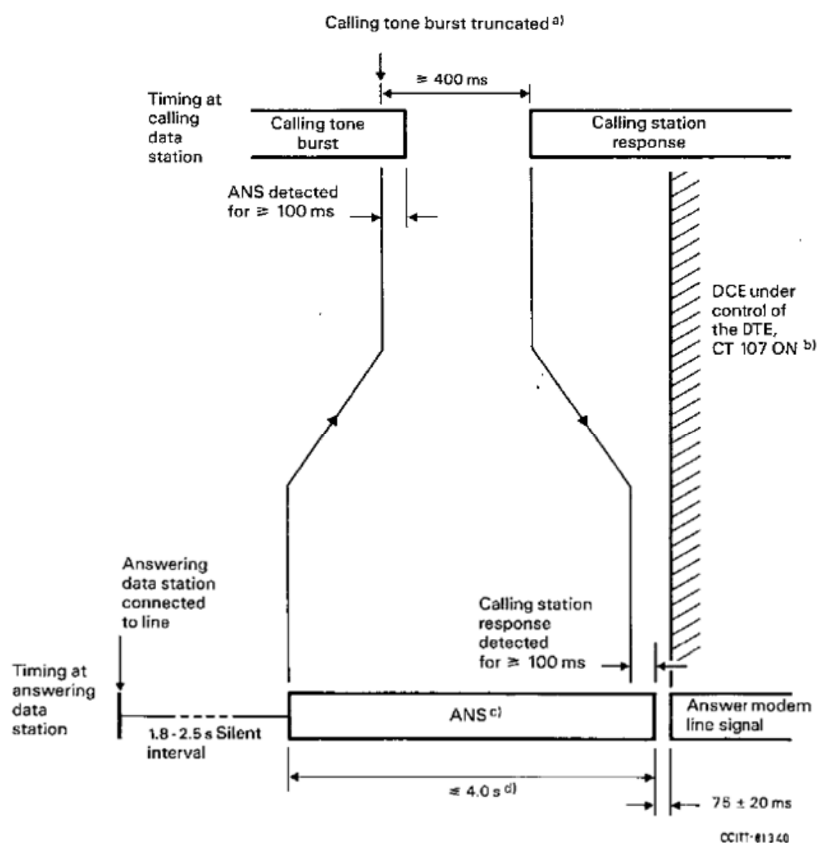
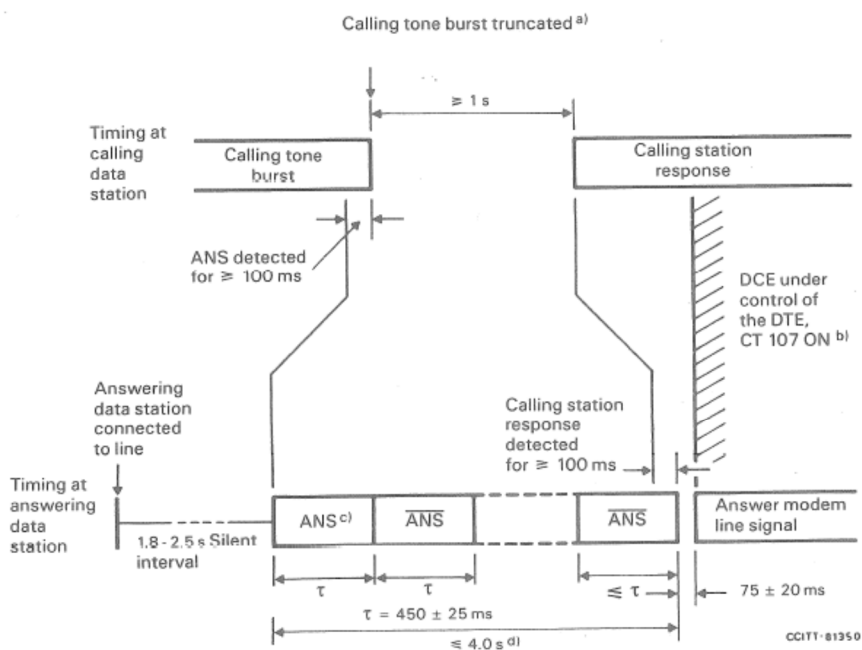

Figure 6: Timing of line signals - Optional calling station response



- a) If ANS is detected during a calling tone burst, the burst may be truncated. If it is not truncated, the calling station response must be delayed until at least 1 second after the end of the burst.
- b) See § 3.20 for exception.
- c) ANS denotes the answer tone.  $\overline{\text{ANS}}$  denotes the answer tone with its phase reversed.
- d) The answer tone duration must be at least 2.6 seconds if a calling station response is not received.

Figure 7: Timing of line signals, optional provision for echo canceller disabling and for calling station response

## 5.2.7 Detector characteristics for Recommendation ITU-T V.32/V.32bis

Operating over the public telephone network, the start-up follows the V.25 answering procedure (see clause 5.2.4).

Recommendation ITU-T V.32 [7] is a modem using phase-shift keying with quadrature amplitude modulation. It operates on a carrier at 1 800 Hz, modulated at 2 400 symbols/s. The basic data rates for Recommendation ITU-T V.32 [7] are 4 800 bits/s and 9 600 bits/s. V.32bis [8] extends the data rates up to 14,400 bits/s.

## 5.2.8 Detector characteristics for Recommendation ITU-T T.30

To activate the De-jitter buffer at calling end respectively called end for procedures according to Recommendation ITU-T T.30 [i.10], the tone detector shall detect frequencies described in table 6.

**Table 6: Events for T.30 Signals**

Signal	Frequency
CED (Called tone which is physically identical to V.25 ANS)	2 100 Hz
/CED Called tone which is physically identical to V.25/ANS)	2 100 Hz with phase reversals at an interval of $450 \pm 25$ ms
CEDam Called tone which is physically identical to V.25 ANSam)	2 100 Hz amplitude-modulated by a sinewave at 15 Hz (Recommendation ITU-T T.30 [i.10], clause 4.1.2; § 6) (Recommendation ITU-T V.34 [i.9])
/CEDam Called tone which is physically identical to V.25 ANSam)	2 100 Hz amplitude-modulated by a sinewave at 15 Hz with phase reversals at an interval of $450 \pm 25$ ms (See note)
CNG (Calling tone)	1 100 Hz
V.21 preamble flag	(V.21 bits)

NOTE: Recommendation ITU-T V.34 [i.9], clause 11.1.2.1: "Upon connection to line, the modem shall initially remain silent for a minimum of 200 ms and then transmit signal ANSam according to the procedure in Recommendation V.8. If duplex operation is intended, this signal shall **include phase reversals** as specified in Recommendation V.8. If half-duplex operation is intended, phase reversals are optional. The modem shall condition its receiver to detect CM and, possibly, calling modem responses from other appropriate Recommendations".

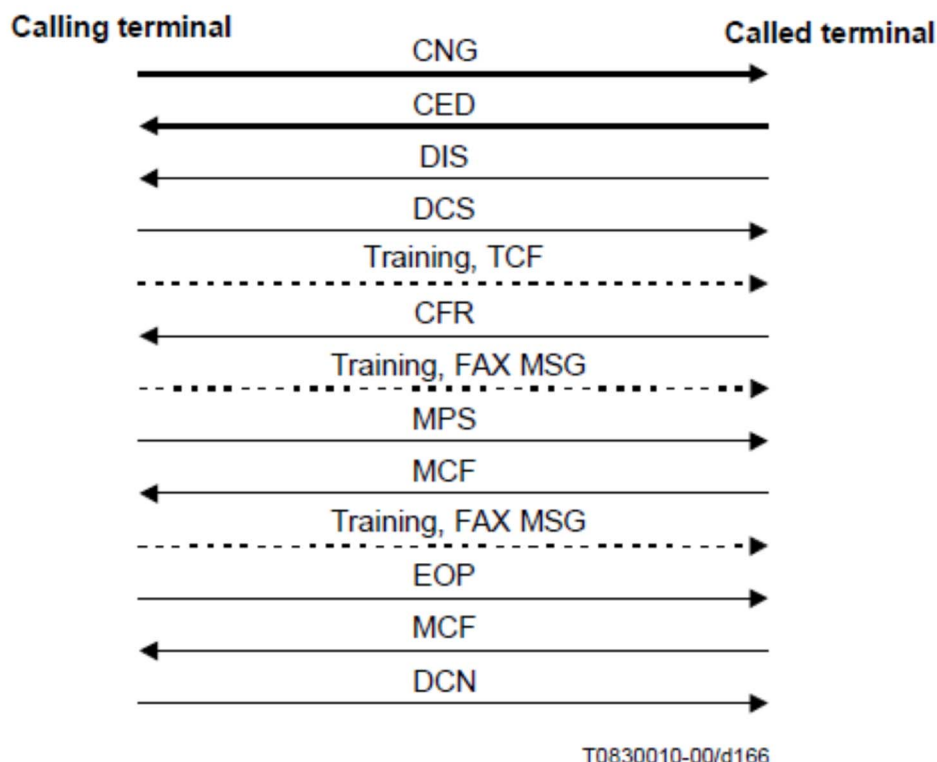

T0830010-00/d166

**Figure 8: T.30 procedure**

The detection channel bandwidth should be chosen wide enough to encompass this tones (and possibly other tones used within national networks). At the same time, the detection channel bandwidth should be such that, in conjunction with guard action and timing, adequate protection is provided against false operation of the detector by speech signals. The detector channel sensitivity (threshold level) should be such that the detector will operate on the lowest expected power of the tone.

### 5.2.9 Noise tolerance

The detector should operate correctly with white noise less than or equal to 11 dB below the level of the signal which should be detected. No definitive guidelines can be given for the range between 5 dB and 11 dB because of the variations in the test equipment used. In particular, performance may vary with the peak-to-average ratio of the noise generator used. It is noted that it is possible to design a detector capable of operating correctly at 5 dB signal-to-noise ratio.

### 5.2.10 Operate time

The operate time should be sufficiently long to provide immunity from false operation due to voice signals, but not so long as to needlessly extend the time to disable. The de-jitter buffer activator is required to operate within one second of the receipt of the activating signal.

### 5.2.11 False operation due to speech signals

It is desirable that the de-jitter buffer activator should rarely operate falsely on speech signals. To this end, a reasonable objective is that, for an de-jitter buffer installed on a working circuit, usual speech signals should not on the average cause more than 10 false operations during 100 hours of speech. In addition to the talk-off protection supplied by the disabling channel bandwidth, by guard band operation and by the operate time, talk-off protection can be supplied by recycling. That is, if speech which simulates the signal is interrupted because of inter-syllabic periods, before changing the de-jitter buffer behaviour has taken place, the operate timing mechanism should reset. However, momentary absence or change of level in a true signal should not reset the timing.

### 5.2.12 Release time

For further study.

### 5.2.13 Other considerations

Both the echo of the activating tone and the echo of the calling tone may disturb the detection of the de-jitter buffer enabling tone. As such, it is not recommended to add the receive and transmit signal inputs together to form an input to a single detector.

---

## 6 Activation of de-jitter buffer for VBD

During telephony mode, the initiating station sends the calling tone (for fax called CNG, 1 100 Hz, a series of interrupted bursts of binary 1 signal or the 1 300 Hz signal (V.25) and while this takes place the user of the receiving station may be continuing to speak or send audio. The station on the left (figure 9) is the initiating station. The speech or audio signal from the station on the right have placed the de-jitter buffer in the dynamic state. The following tones shall drive both, de-jitter buffers JB2 and JB1 into the fixed mode.

- CED as per Recommendation ITU-T T.30 [i.10]
- ANS as per Recommendation ITU-T V.8 [1]
- ANSam as per Recommendation ITU-T V.8 [1]
- /ANSam as per Recommendation ITU-T V.8 [1]
- Preamble as per Recommendation ITU-T T.30 [i.10], section 5.3.1
- 2 225 Hz answer tone as per Recommendation ITU-T V.150.1 [i.11], appendix VI
- Unscrambled binary 1 is detected for  $155 \pm 50$  ms as per Recommendation ITU-T V.22 [5]

- Segment 1 dual tones (1 529 + 2 225) as per Recommendation ITU-T V.8bis [2]

NOTE 1: Whereas the operation of JB2 does not constitute a problem, the activation of JB1 may need special attention. This scenario is illustrated in figure 9.

These scenarios are illustrated in figures 8a, 9 and 10.

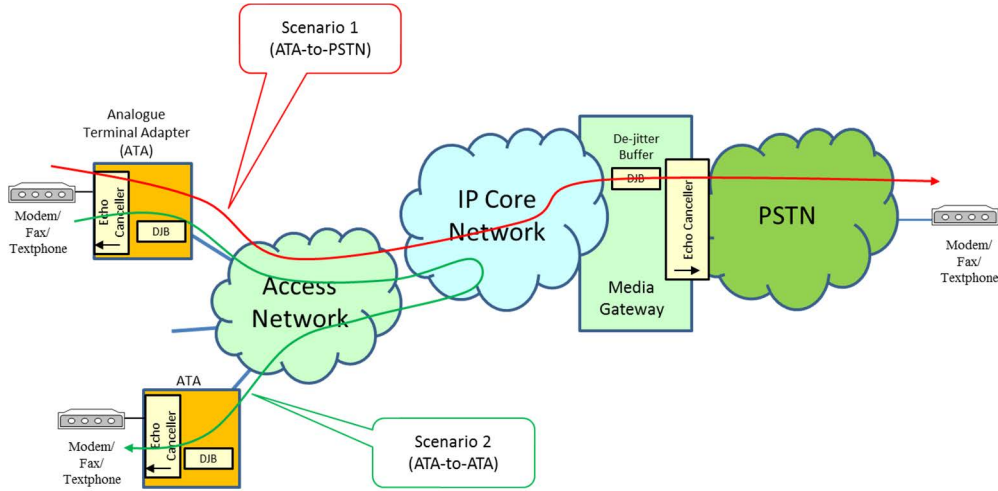

Figure 8a: Diagram showing voice service scenario [i.18]

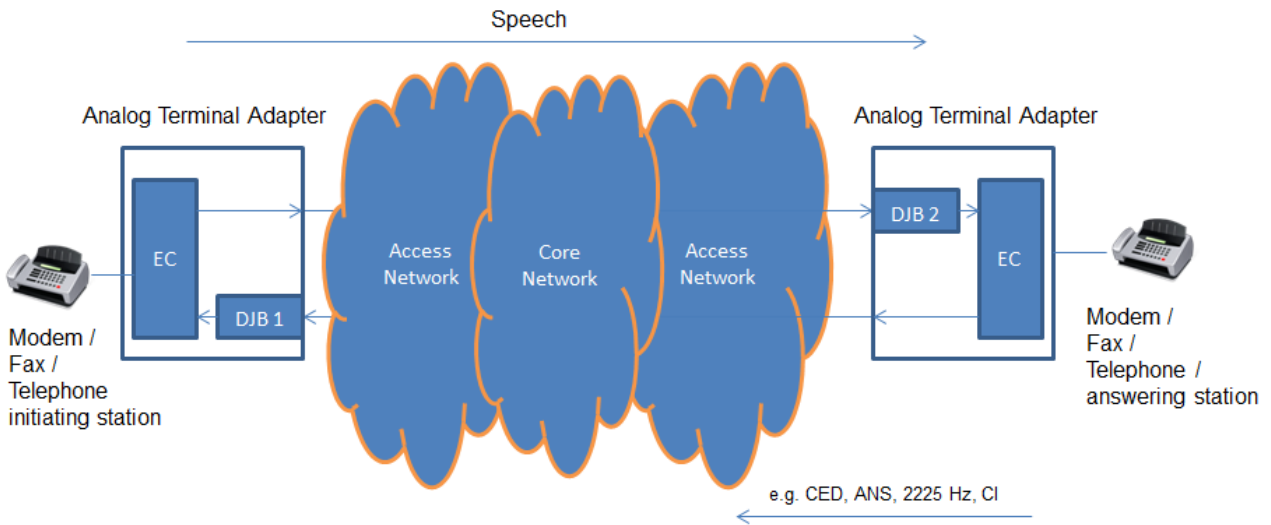
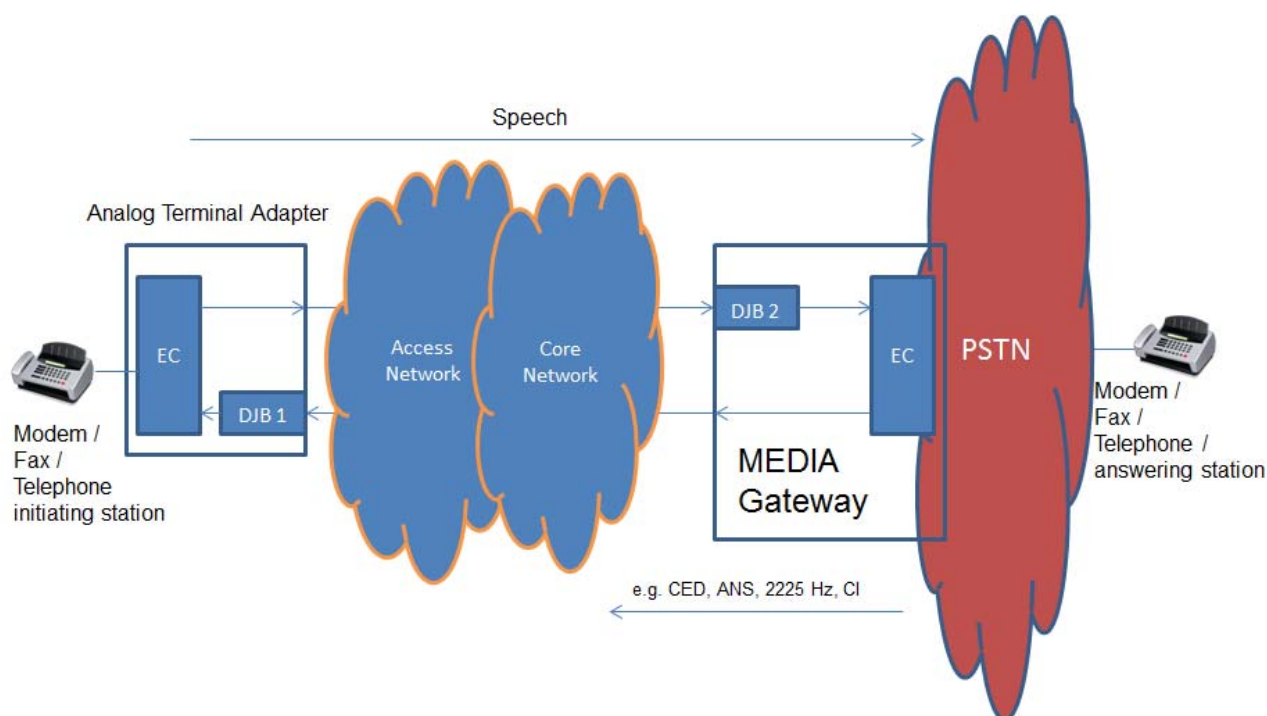
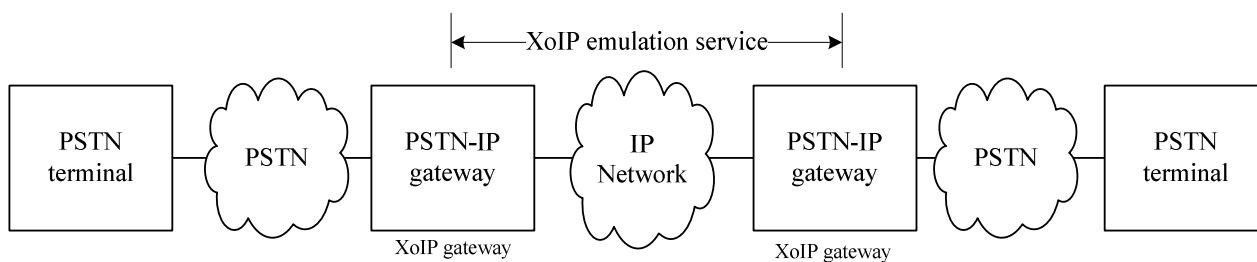

Figure 9: Activation of de-jitter buffer for VBDolP between two ATA



**Figure 10: Activation of de-jitter buffer for VBDolP between ATA and MGW**

Figure 11 recalls again the typical network configuration for PSTN emulation services in NGN. There are two PSTN-IP gateways involved in case of the considered two-party communication by the present document. The gateways have to provide a dedicated XoIP emulation service, dependent on the PSTN modem call type.



**Figure 11: Typical network configuration for PSTN emulation services**

The typical activation and configuration of de-jitter buffers is illustrated at the example of a PSTN fax/modem call, see figure 12.

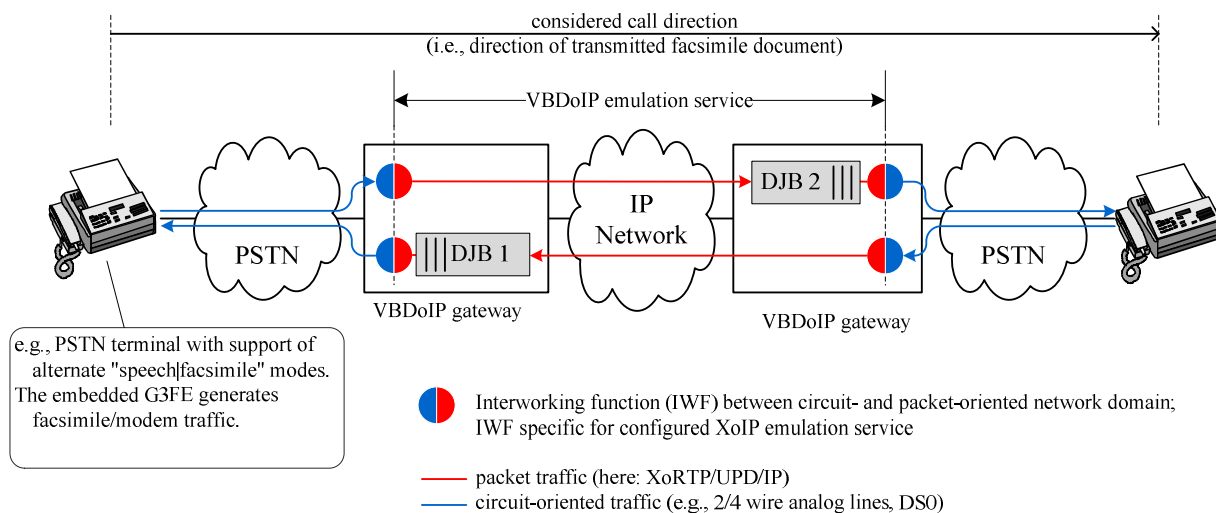

**Figure 12: Example of a VBDiP emulation service**

The VBDiP gateway provides two main modes of operation at IP side: audio mode (VoIP) and voiceband data mode (VBDiP), see [9].

NOTE 2: It has to be noted that such a state model is undefined in case of pseudo-VBDiP emulation service (see clause 3.1.9 of the present document), leading ambiguity, different interpretations and deployed implementations.

According to Recommendation ITU-T V.152 [9] the early VBD detection procedure shall be used. In that case the following initiating **calling tones** shall be recognized from the detector which shall drive the de-jitter buffer JB1 and JB2 into the fixed mode:

- CI (V.21 bits) signal V.8 (1 180 Hz, 980 Hz, 1 850 Hz, 1 650 Hz)
- CNG, 1 100 Hz, (T.30, V.8)
- CT, 1 300 Hz signal (V.25)
- a series of interrupted bursts of binary 1 signal
- unscrambled binary ones signal as per Recommendation ITU-T V.22 [5]
- initiating Segment 1 dual tones (1 375 Hz and 2 002 Hz) as per Recommendation ITU-T V.8bis [2]

In the case when the calling tones, needed to activate the early VBD detection, were not detected and the de-jitter buffers were not activated the signals generated from the **called side** shall be recognized from the detector which shall drive the de-jitter buffers JB1 and JB2 into the fixed mode as described in the clause before.

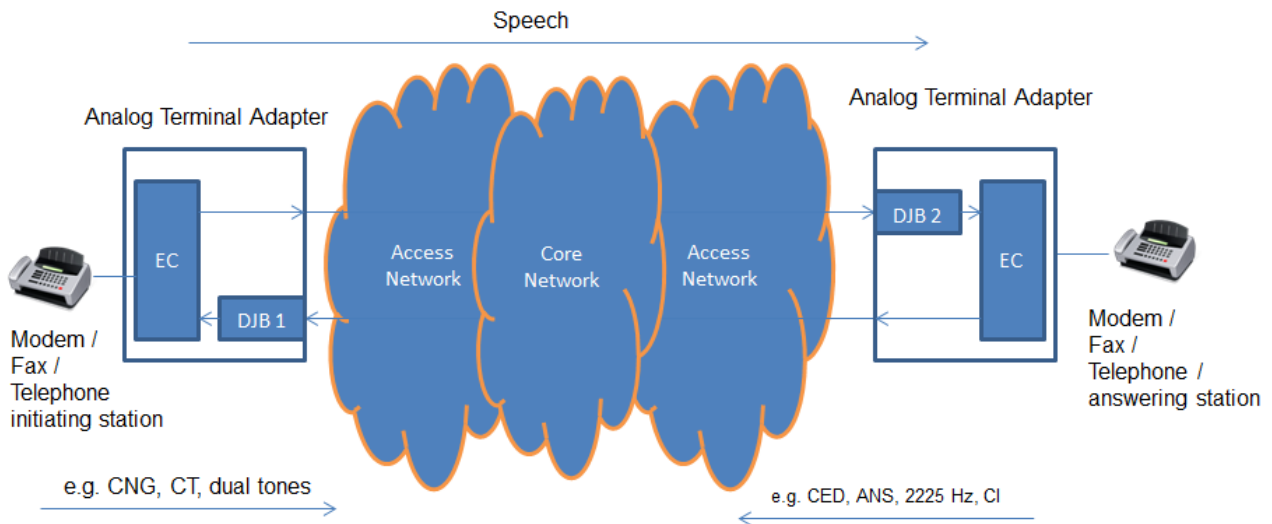

Figure 13: Early VBD detection procedure

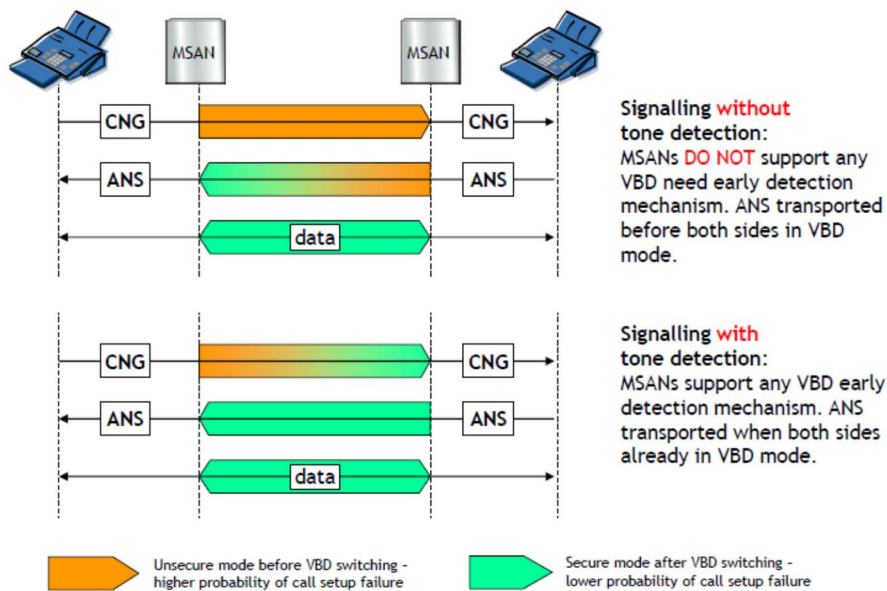

Figure 14: Signalling with and without VBD early detection

To minimize the risk of carrier lost, packet loss concealment described in Recommendation ITU-T G.711 [i.13], appendix I shall be supported.



## 7 Activation of de-jitter buffer for 64 kbit/s bit sequence (UDI)

ISDN provides circuit-mode data services besides audio. The ISDN bearer service [i.19] is used for *unrestricted digital information* (UDI) and consumes a single ISDN B-channel (64 kbit/s) in the ISDN network domain. IP networks need to support *circuit emulation services* (CESoIP) for the general category of ISDN circuit-mode data services. The so-called clearmode (CMD), according [i.20], could be used as XoIP emulation service for [i.19] traffic. The protocol stack of the CMDoIP emulation service relates to a "1x64/CMD/RTP/UDP/IP" transport. It has to be noted that general Nx64 circuit-mode data services (with N greater than 1) are out of scope of [i.20]. Figure 15 illustrates the example network configuration:

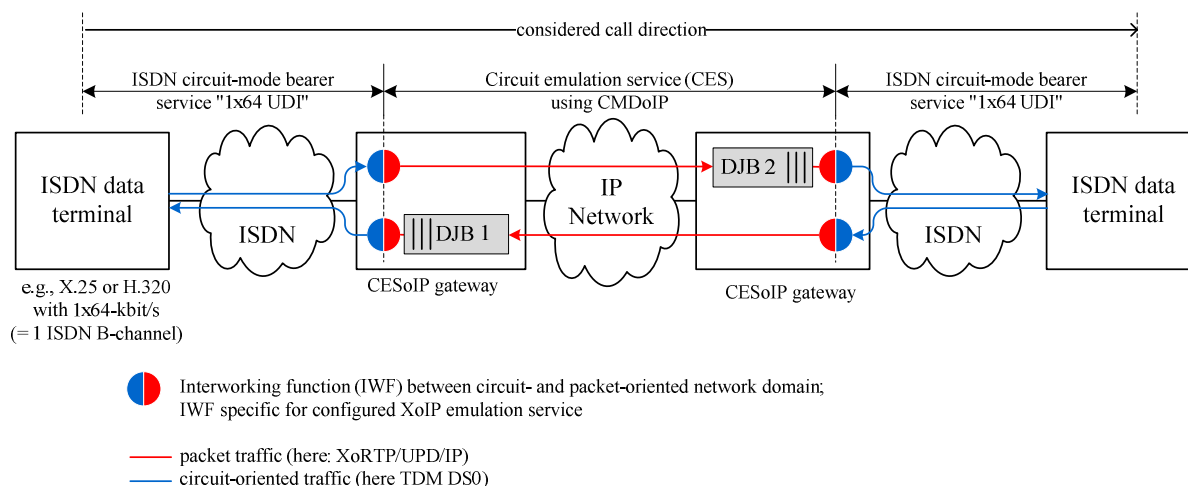

**Figure 15: Example of a CMDoIP emulation service**

PSTN voiceband data and ISDN circuit-mode data services share the same requirement of constant end-to-end transfer delay, leading to fixed DJB configurations in the gateways.

However, there is not any kind of inband signalling in case of ISDN circuit-mode data service, in contrast to the modem-based signalling procedures in case of PSTN voiceband data. The particular ISDN bearer service (here [i.19]) is indicated in ISDN call control signalling (such as [i.21] at ISDN UNI or ISUP/SS7 at ISDN NNI. Gateway to gateway signalling in the IP domain uses again not any kind of IP in-path signalling (such as in case of V.152, T.38), rather an explicit indication at IP call control signalling (e.g. in case of SIP the SDP attribute "a=rtpmap:... CLEARMODE/8000" within in the media configuration).

The DJB handling is illustrated in figure 16.

The fixed de-jitter buffer from the calling and called side for 64 kbit/s bit sequence (UDI) shall be activated directly by call control signalling. The activation takes place at the latest with the reception of call control stimuli such as Connect/ANM (ISUP) in the ISDN domain or 200 OK (SIP) message in the IP domain.

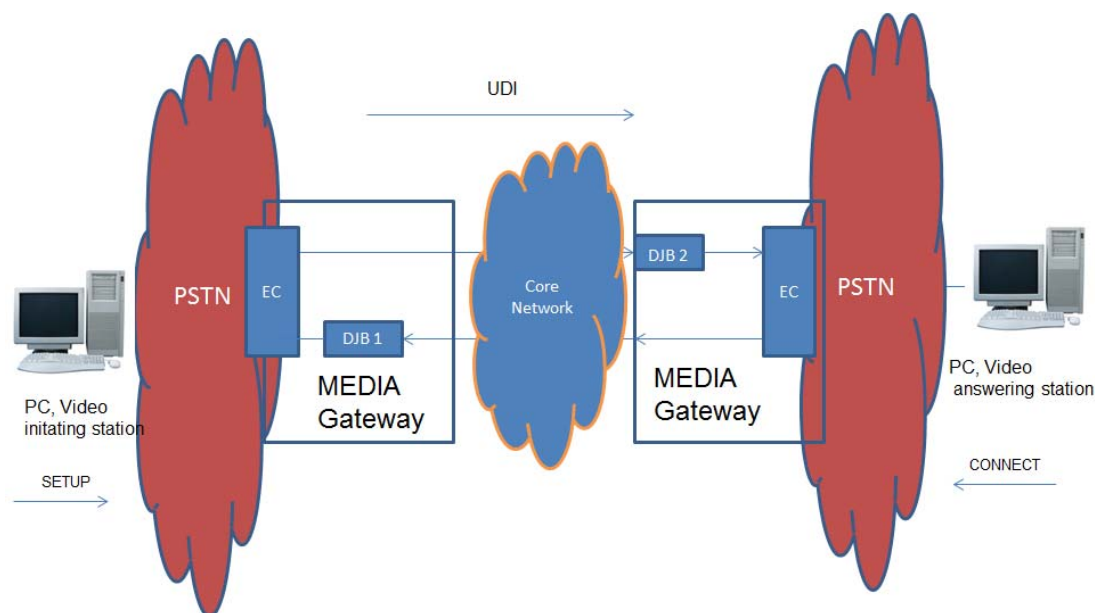

**Figure 16: Activation of de-jitter buffer for clear mode (CMDoIP) activated directly by call control signalling**

## 8 Requirements for values of de-jitter buffers

### 8.1 Fixed de-jitter buffers

In case VBD it is the goal to keep the audio end-to-end delay constant during the entire call. The de-jitter buffer has to be implemented in such a way that any jitter occurring during the entire call will not change the end to end delay.

The de-jitter buffer may adapt if there is an overflow or under run.

### 8.2 Adaptive de-jitter buffers

In case of voice the strategy of de-jitter buffer implementation is to keep the end to end audio delay as low as possible under all jitter conditions. Any de-jitter buffer implementation should mostly not impair the listening speech quality as perceived by the user.

For voice calls between MSAN, IAD, MGW adaptive de-jitter buffers are required. The minimum de-jitter buffer size should be smaller or equal to one packet size.

For adaptive de-jitter buffers the maximum aberration from the real jitter in the network should be one packetization time interval. It is recommended that the jitter measurement period for Jitter should be 2 - 3 packet intervals, not only on one packet interval. The adaptation interval towards higher values should be done immediately after the jitter measurement period. The adaptation towards lower values should be after at least several seconds or during silence periods.

### 8.3 Activation procedure into the fixed mode

The detection of the initiating calling tones should be maximal 200 ms, after that the De-jitter buffer shall adapt the de-jitter buffer state from the adaptive to the fixed de-jitter buffer state. "When the JB adapts to the fixed state, there will be some time (JB adaption time) without audio information due to the increasing JB-delay, which will often be replaced with supposed audio information by a PLC-algorithm."

In some cases, the JB adaption time can be critical, especially if this time is higher. In this case the early VBD detection procedure should be used.

**Table 7: Examples of de-jitter buffer adaption time**

<b>De-jitter buffer Adaptive</b>	<b>De-jitter buffer Fixed</b>	<b>De-jitter buffer adaption time</b>
20 ms	100 ms	40 ms
20 ms	200 ms	90 ms
40 ms	100 ms	30 ms
40 ms	200 ms	80 ms

## 8.4 Transition from VBD to Voice mode (Recommendation ITU-T V.152)

Transition from VBD to Voice may be carried out by detection:

- In the direction from the GSTN to IP network of any of the following stimuli:
  - end of modem or facsimile signals;
  - voice signals;
  - detection in both directions, GSTN to IP and IP to GSTN, of silence. With the following caveats:
    - For text telephones the appropriate detection of silence shall be considered because text telephone conversations may have long periods of silence.
    - For the case of facsimile calls the silence period should be greater than the T2 timer defined in Recommendation ITU-T T.30 [i.10].
  - MGC signalling or other out of band signalling method.
- In the direction from IP to GSTN network due to receipt of RTP packets that have non-VBD payload types only after the first VBD RTP packet has been received. This will avoid the situation of an incorrect transition into Audio mode when it has transitioned to VBD mode on detection of VBD signals on its TDM side and is still receiving Voice RTP packets (because the remote end has not yet transitioned based on reception of the VBD RTP packets).

The above described transition criteria are also summarized in figure 17.

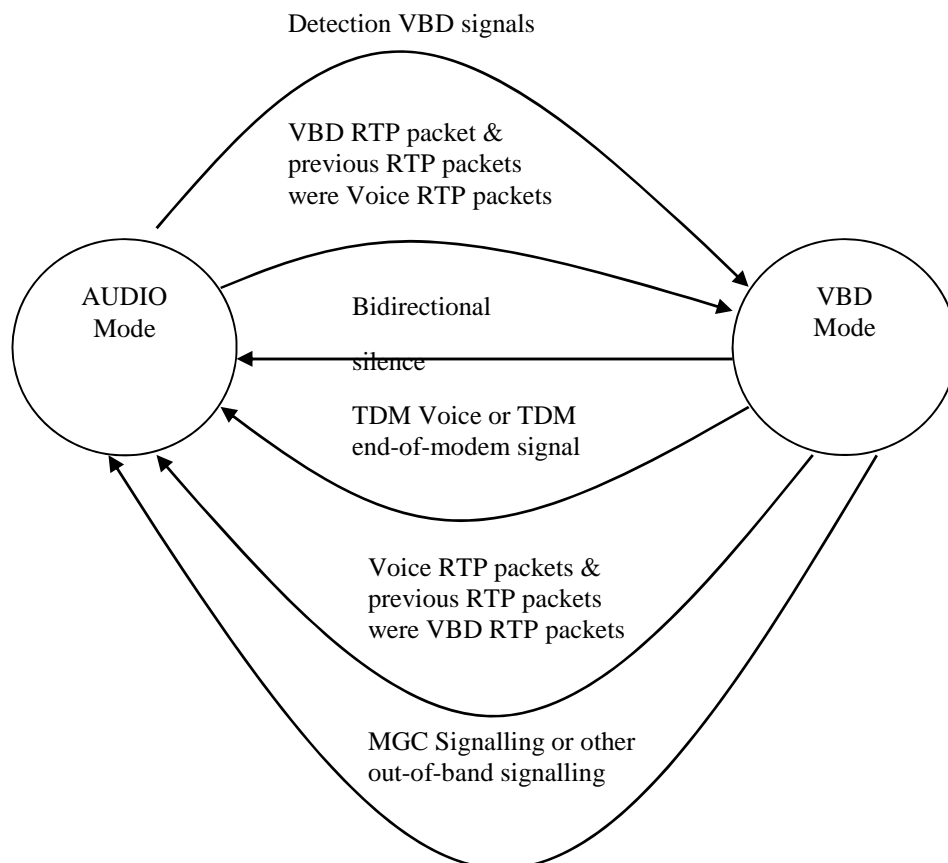

**Figure 17: Voice-VBD Transitioning state diagram**  
(Figure 1 from Recommendation ITU-T V.152 [9])

## 8.5 Handling of De-jitter buffer in case of lost or late packets

As the receiving decoder expects to be fed with voice packets at the same fixed rate, the de-jitter buffer shall insert dummy packets if the packets are lost, or they arrived too late. Depending of the De-jitter buffer algorithm, the lost packets will often be replaced with supposed audio information by a PLC-algorithm.

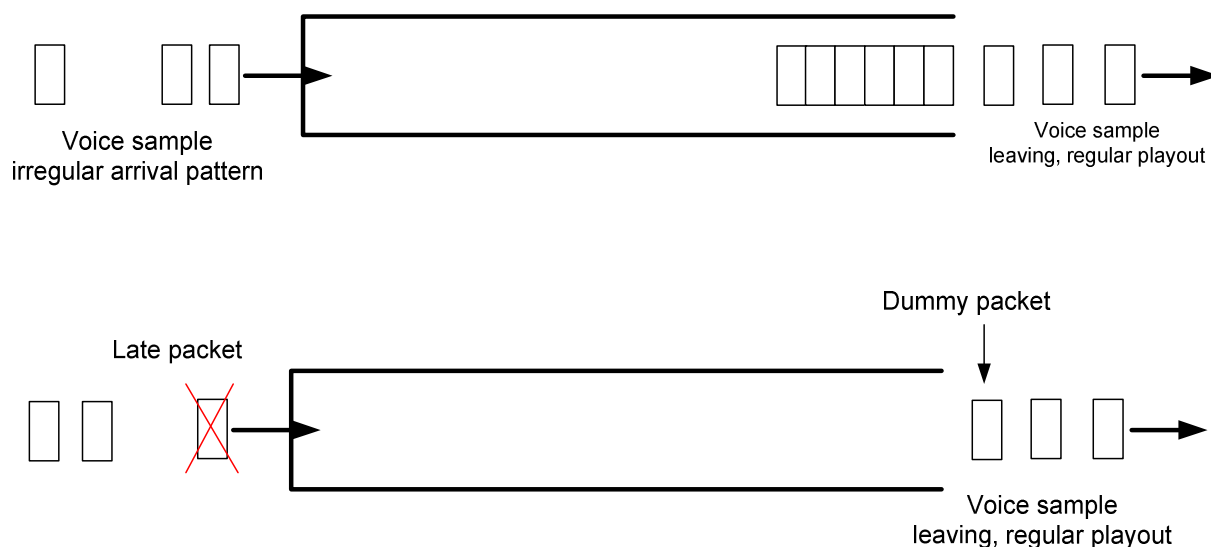

**Figure 18: Handling of De-jitter buffer in case of lost or late packets**

## 9 Echo canceller

### 9.1 Introduction

As a general rule, echo cancellers are required in VoIP systems due to the high transmission delay.

In accordance with Recommendations ITU-T G.131 [i.5] and Q.115.1 [i.6] echo canceller (EC) according to Recommendation ITU-T G.168 [3] shall be used if the mean one way delay of the "talker echo transmission path" exceeds the 25 ms limit.

False detection of tones leading to switch off of an echo canceller during a speech call has to be prevented (similar to clause 4.2 for de-jitter buffer setting).

### 9.2 Characteristics of an echo canceller tone disabler (Recommendation ITU-T G.168)

#### 9.2.1 General

The echo cancellers implemented according Recommendation ITU-T G.168 [3] should be equipped with a tone detector that conforms to this clause. This tone detector should disable the echo canceller only upon detection of a signal which consists of a 2 100 Hz tone with periodic phase reversals inserted in that tone, and not disable with any other in-band signal, e.g. speech or a 2 100 Hz tone without phase reversals. The tone disabler should detect and respond to a disabling signal which may be present in either the send or the receive path.

To improve the operation of the echo canceller for fax signals and low-speed voiceband data, it may be beneficial for some echo cancellers to disable the NLP for such calls. In this case, the echo canceller may optionally detect any 2 100 Hz tone without phase reversals. If 2 100 Hz tone without phase reversal is detected, the echo canceller shall remain enabled, and the NLP may optionally be disabled. The frequency characteristics of the tone detector are given in figure 15.

The tone disabler characteristics as specified in clauses 7.4 through 7.9 in Recommendation ITU-T G.168 [3] also apply for this NLP disabling detector.

Note that if the 2 100 Hz tone contains phase reversals, then the echo canceller shall be disabled as defined elsewhere in this clause.

The term disabled in this clause refers to a condition in which the echo canceller is configured in such a way as to no longer modify the signals which pass through it in either direction. Under this condition, no echo estimate is subtracted from the send path, the non-linear processor is made transparent, and the delay through the echo canceller still meets the conditions specified in clause 6.4.1.9 in Recommendation ITU-T G.168 [3]. However, no relationship between the circuit conditions before and after disabling should be assumed. The impulse response stored in the echo canceller prior to convergence (and prior to the disabling tone being sent) is arbitrary. This can lead to apparent additional echo paths which, in some echo canceller implementations, remain unchanged until the disabling tone is recognized. Also note that echo suppressors could be on the same circuit and there is no specified relationship between their delay in the enabled and disabled states. In spite of the above, it is possible, for example, to measure the round-trip delay of a circuit with the disabling tone but the trailing edge of the tone burst should be used and sufficient time for all devices to be disabled should be allotted before terminating the disabling tone and starting the timing. It should be noted that the echo canceller should provide 64 kbit/s bit-sequence integrity when disabled.

#### 9.2.2 Detector characteristics

The tone detector shall detect a tone in the frequency range of 2 100 Hz  $\pm$  21 Hz (see Recommendation ITU-T V.21 [4]).

The detection channel bandwidth should be chosen wide enough to encompass this tone (and possibly other disabling tones used within national networks). At the same time, the detection channel bandwidth should be such that, in conjunction with guard action and timing, adequate protection is provided against false operation of the detector by speech signals. The detector channel sensitivity (threshold level) should be such that the detector will operate on the lowest expected power of the disabling tone. The band characteristics shown in figure 19 will permit disabling by the 2 100 Hz disabling tone as well as others used in North America. The figure indicates that in the frequency band 2 079 Hz to 2 121 Hz detection **shall** be possible whilst in the band 1 900 Hz to 2 350 Hz detection **may** be possible.

Providing that only the recommended 2 100 Hz disabling tone is used internationally, interference with signalling equipment will be avoided.

The dynamic range of the detector should be consistent with the input levels as specified in Recommendation ITU-T V.21 [4] with allowances for variation introduced by the public switched telephone network.

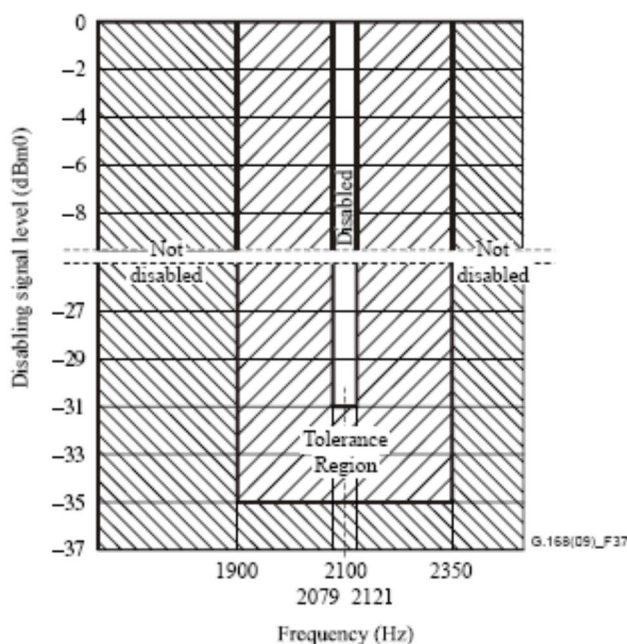

Figure 19: Required disabling band characteristics

### 9.2.3 Phase reversal detection

The echo canceller tone disabler requires the detection of a 2 100 Hz tone with periodic phase reversals which occur every  $450 \pm 25$  ms. The characteristics of the transmitted signal are defined in Recommendations ITU-T V.25 [6] and V.8 [1]. Phase variations in the range of  $180^\circ \pm 25^\circ$  should be detected while those in the range of  $0^\circ \pm 110^\circ$  should not be detected. This restriction is to minimize the probability of false disabling of the echo canceller due to speech currents and network-induced phase changes. The  $\pm 110^\circ$  range represents the approximate phase shift caused by a single frame slip in a PCM system.

### 9.2.4 Guard band characteristics

Energy in the voiceband, excluding the disable band, shall be used to oppose disabling so that speech will not falsely operate the tone disabler. The guard band should be wide enough and with a sensitivity such that the speech energy outside the disabling band is utilized. The sensitivity and shape of the guard band shall not be such that the maximum idle or busy circuit noise will prevent disabling. In the requirement, white noise is used to simulate speech and circuit noise. Thus, the requirement follows.

Given that white noise (in a band of approximately 300 Hz to 3 400 Hz) is applied to the tone disabler simultaneously with a 2 100 Hz signal, the 2 100 Hz signal is applied at a level 3 dB above the midband disabler threshold level. The white noise energy level required to inhibit disabling should be no greater than the level of the 2 100 Hz signal and no less than a level 5 dB below the level of the 2 100 Hz signal. As the level of the 2 100 Hz signal is increased over the range of levels to 30 dB above the midband disabler threshold level, the white noise energy level required to inhibit disabling should always be less than the 2 100 Hz signal level. These requirements, together with the noise tolerance requirements given in clause 9.1.5 are illustrated in figure 20.

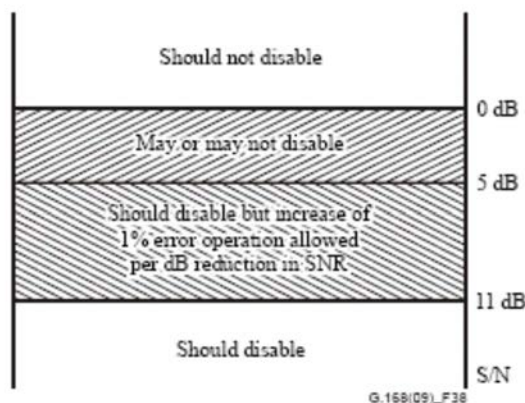

**Figure 20: Guard band and noise tolerance requirements**

**NOTE:** The possibility of interference during the phase reversal detection period has been taken into account. One potential source of interference is the presence of calling tone as specified in Recommendation ITU-T V.25 [6]. If the calling tone interferes with the detection of the phase reversal, the entire disabling detection sequence is restarted, but only one time. Recommendation ITU-T V.25 [6] ensures at least one second of quiet time between calling tone bursts.

### 9.2.5 Noise tolerance

The detector should operate correctly with white noise less than or equal to 11 dB below the level of the 2 100 Hz signal. No definitive guidelines can be given for the range between 5 dB and 11 dB because of the variations in the test equipment used. In particular, performance may vary with the peak-to-average ratio of the noise generator used. As a general guideline, however, the percentage of correct operation (detection of phase variations of  $180^\circ \pm 25^\circ$  and non-detection of phase variations of  $0^\circ \pm 110^\circ$ ) should fall by no more than 1 % for each dB reduction in the signal-to-noise ratio below 11 dB. It is noted that it is possible to design a detector capable of operating correctly at 5 dB signal-to-noise ratio.

### 9.2.6 Holding-band characteristics

The tone detector, after disabling either the NLP or the echo canceller, should hold the NLP or echo canceller in the disabled state for tones in a range of frequencies specified below. The release sensitivity should be sufficient to maintain disabling for the lowest level data signals expected, but should be such that the detector will release for the maximum idle or busy circuit noise. Thus the requirement follows:

- The tone detector should hold the NLP or echo canceller in the disabled state for any single-frequency sinusoid in the band from 390 Hz to 700 Hz having a level of -27 dBm0 or greater, and from 700 Hz to 3 000 Hz having a level of -31 dBm0 or greater. The tone disabler should release for any signal in the band from 200 Hz to 3 400 Hz having a level of -36 dBm0 or less.

**NOTE:** If this function is not implemented (as in many gateways to date), it can lead to situations, where the echo canceller is switched off, even if it should be switched on again. This can be the case in the following situation: V.17 Fax calls V.34 Fax  $\geq$  Answer tone will be for V.34 ( $\geq$  EC off), connection will be V.17 (EC should be on).

### 9.2.7 Operate time

The operate time should be sufficiently long to provide immunity from false operation due to voice signals, but not so long as to needlessly extend the time to disable. The tone disabler is required to operate within one second of the receipt of the disabling signal. The one second operate time permits the detection of the 2 100 Hz tone and ensures that two-phase reversals will occur.

## 9.2.8 False operation due to speech currents

It is desirable that the tone disabler should rarely operate falsely on speech. To this end, a reasonable objective is that, for an echo canceller installed on a working circuit, usual speech currents should not on the average cause more than 10 false operations during 100 hours of speech.

In addition to the talk-off protection supplied by the disabling channel bandwidth, by guard band operation and by the operate time, talk-off protection can be supplied by recycling. That is, if speech which simulates the disabling signal is interrupted because of inter-syllabic periods, before disabling has taken place, the operate timing mechanism should reset. However, momentary absence or change of level in a true disabling signal should not reset the timing.

## 9.2.9 False operation due to data signals

It is desirable that the tone disabler should rarely operate falsely on data signals from data sets that would be adversely affected by disabling the echo canceller. To this end, a reasonable objective is that, for an echo canceller installed on a working circuit, usual data signals from such data sets should not, on the average, cause more than 10 false operations during 100 hours of data transmissions.

To this end, in the reference tone disabler described in annex B of Recommendation ITU-T G.165 [i.2], which meets the above requirements, the tone disabler circuitry becomes inoperative if one second of clear (i.e. no phase reversals or other interference) 2 100 Hz tone is detected. The detector circuit remains inoperative during the data transmission and only becomes operative again  $250 \pm 150$  ms after a signal in the holding band falls at least 3 dB below the maximum holding sensitivity. Thus the possibility of inadvertent disabling of the echo canceller during facsimile or low speed (< 9,6 kbit/s) voiceband data transmission is minimized.

## 9.2.10 Release time

The disabler should not release for signal drop-outs less than the ITU-T recommended value of 100 ms. To cause a minimum of impairment upon accidental speech disabling, it should release within  $250 \text{ ms} \pm 150 \text{ ms}$  after a signal in the holding band falls at least 3 dB below the maximum holding sensitivity in both directions of signal transmission.

## 9.2.11 Other considerations

Both the echo of the disabling tone and the echo of the calling tone may disturb the detection of the echo canceller disabling tone. As such, it is not recommended to add the receive and transmit signal inputs together to form an input to a single detector.

Careful attention should be given to the number of phase reversals required for detection of the disabling tone. Some Administrations favour relying on 1 to improve the probability of detection even in the presence of slips, impulse noise, and low signal-to-noise ratio. Other Administrations favour relying on 2 to improve the probability of correctly distinguishing between non-phase-reversed and phase-reversed 2 100 Hz tones, and to reduce the likelihood of false triggering of the tone disabler by speech or data signals.



## Annex A (normative): De-jitter buffer Facsimile tests

### A.1 Measurement method

These tests should ensure that the De-jitter buffer located at each end of a connection converge rapidly on the initial handshaking sequences of a facsimile call. The test and requirements were originally developed to overcome problems in the network due to the turnaround of fax and modem handshaking signals.

The test method is based on the analysis of measurement of delay over time of the device under test. Artificial introduced jitter can be used to help with this analysis.

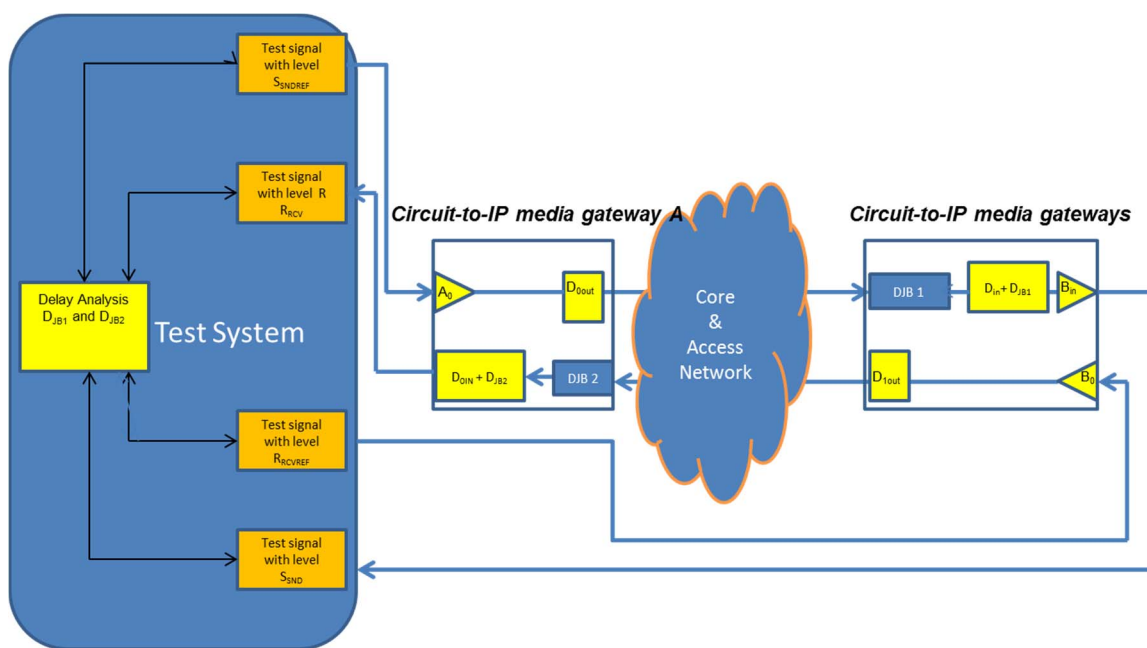

Figure A.1: Test configuration A calls B

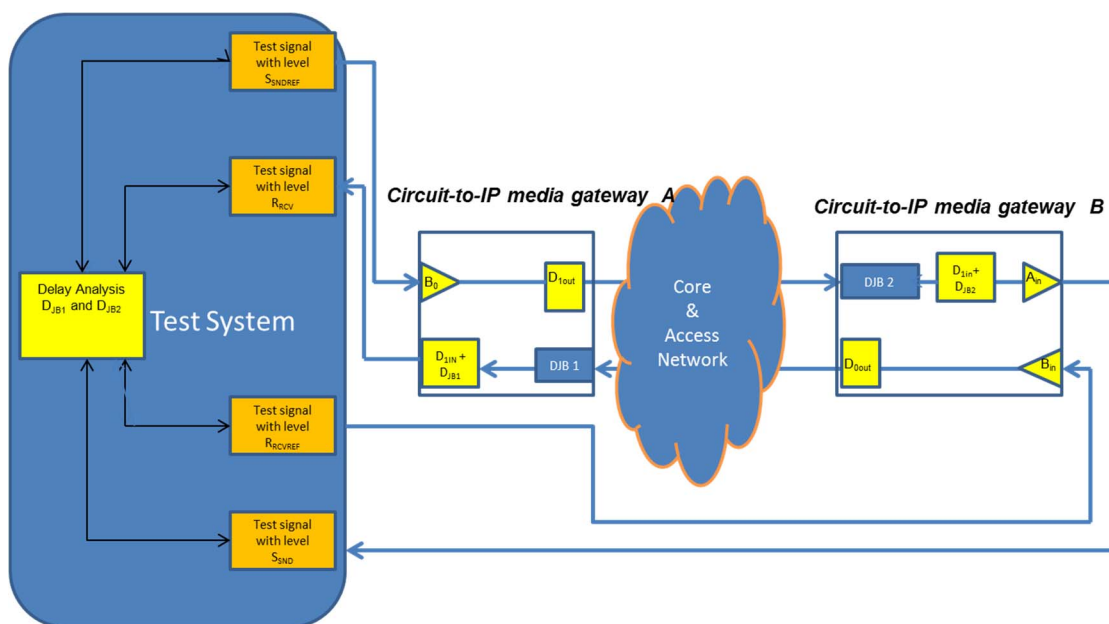

Figure A.2: Test configuration B calls A

$A_0$  - output level interface A  
 $A_{in}$  - input level interface A  
 $B_{in}$  - input level interface B  
 $B_0$  - output level interface B  
 $D_{0out}$  - sending delay interface A (coder delay, see table 22 of [1])  
 $D_{JB1}$  - de-jitter buffer delay interface B  
 $D_{1in}$  - receiving delay interface B (Decompression time per block + Serialization time + PLC)  
 $D_{1out}$  - sending delay interface B (coder delay, see table 22 of [1])  
 $D_{JB2}$  - de-jitter buffer delay interface A  
 $D_{0in}$  - receiving delay interface B (Decompression time per block + Serialization time + PLC)

NOTE: Decoder delay =  $D_{in} + D_{JB}$ .

#### Used signals

C16	Signal of Test 2A (Recommendation ITU-T G.168 [3]), average level -16 dBm0 Gaussian white noise signal which is used to identify the echo-path impulse response.
D16	Signal consisting of DTMF tones <b>0123456789#ABCD*</b> with signal-to-pause relationship corresponding to that of C16, average level -16 dBm0.
ANS	2 100 Hz sine (Recommendation ITU-T V.25 [6]) The duration of the tone is set to $T1 = 1,35$ s.
ANSam	2 100 Hz sine with a 20 % amplitude modulation by a 15 Hz sine (Recommendation ITU-T V.25 [6]).
/ANS	2 100 Hz sine with 180° phase shift every 450 ms (Recommendation ITU-T V.25 [6]).
/ANSam	2 100 Hz sine with a 20 % amplitude modulation by a 15 Hz sine and 180° phase shift every 450 ms (Recommendation ITU-T V.25 [6]).
CI	CI sequence consists of 10 ONEs followed by 10 synchronization bits and the call function octet. For the transmission are used 980 Hz for '1' (mark) and 1 180 Hz for '0' (space) (low channel uses) and the frequencies 1 650 Hz for '1' and 1 850 Hz for '0' (high channel uses).
CT	1 300 Hz sine CT (calling tone) consists of a series of interrupted bursts of 1 300-Hz tone, on for a duration of not less than 0,5 s and not more than 0,7 s and off for a duration of not less than 1,5 s and not more than 2,0 s.
CNG	1 100 Hz sine Duration On for 0,5 s to 0,7 s, Off 1,8 s to 2,5 (Recommendation ITU-T V.25 [6]).
FAX	Sequence No. 1 (Recommendation ITU-T G.168 [3], clause 6.4.2.11).

Table A.1: Test overview

Test number	Transmission Type	Options
<b>Fax Tests</b>		
1.1.1 FAX	Facsimile with ANS/-12 dBm0	M
1.1.2 FAX	Facsimile with ANS/-31 dBm0	M
1.2.1 FAX	Facsimile with early VBD detection with CNG/-12 dBm0	O
1.2.2 FAX	Facsimile with early VBD detection with CNG/-31 dBm0	O
1.3.1 FAX	Facsimile with early VBD detection with V.17 data transmission with ANS/-12 dB	O
1.3.2 FAX	Facsimile with early VBD detection with V.17 data transmission with ANS/-31 dBm0	O
1.4.1 FAX	Facsimile with /ANS/-12 dBm0	M
1.4.2 FAX	Facsimile with /ANS/-31 dBm0	M
1.5.1 FAX	Facsimile with V.34 data transmission with /ANS/-12 dBm0	M
1.5.2 FAX	Facsimile with V.34 data transmission with /ANS/-31 dBm0	M
1.6.1 FAX	Facsimile with /ANSam/-12 dBm0	M
1.6.2 FAX	Facsimile with /ANSam/-31 dBm0	M
1.7.1 FAX	Facsimile with V.34 data transmission with /ANSam/-12 dBm0	M
1.7.2 FAX	Facsimile with V.34 data transmission with /ANSam/-31 dBm0	M
<b>Modem Tests</b>		
2.1.1 MODEM	Modem with ANS/-12 dBm0	M
2.1.2 MODEM	Modem with ANS/-31 dBm0	M
2.2.1 MODEM	Modem with early VBD detection with CT/-12 dBm0	O
2.2.2 MODEM	Modem with early VBD detection with CT/-31 dBm0	O
2.3.1 MODEM	Modem with ANSam/-12 dBm0	M
2.3.2 MODEM	Modem with ANSam/-31 dBm0	M
2.4.1 MODEM	Modem with early VBD detection with CI Signal (V.8)/-12 dBm0	O
2.4.2 MODEM	Modem with early VBD detection with CI Signal (V.8)/-31 dBm0	O
2.5.1 MODEM	Modem with /ANS/- 12 dBm0	M
2.5.2 MODEM	Modem with /ANS/-31 dBm0	M
2.6.1 MODEM	Modem with /ANSam/- 12 dBm0	M
2.6.2 MODEM	Modem with /ANSam/-31 dBm0	M

<b>Test number:</b>	<b>1.1.1 FAX</b>
<b>Transmission Type:</b>	Facsimile with <b>ANS</b> /-12 dBm0
<b>Measurement procedure</b>	<p>I)</p> <ul style="list-style-type: none"> <li>• Establishing a new call from A to B and reset De-jitter buffer 1 and De-jitter buffer 2</li> <li>• Apply signal C16 to Interface A and determine the delay <math>D_{JB1}</math></li> <li>• Apply signal C16 to Interface B and determine the delay <math>D_{JB2}</math></li> <li>• Establishing a new call from A to B and reset De-jitter buffer 1 and Jitter Buffer 2</li> <li>• Apply signal ANS to Interface B</li> <li>• Apply signal C16 to Interface A and determine the delay <math>D_{JB1}</math> after sending ANS (from B)</li> <li>• Apply signal C16 to Interface B and determine level <math>S_{SND}</math> and <math>R_{CV}</math> and the delay <math>D_{JB2}</math> after sending ANS (from B)</li> </ul> <p>II)</p> <ul style="list-style-type: none"> <li>• Establishing a new call from B to A and reset De-jitter buffer 1 and De-jitter buffer 2</li> <li>• Apply signal C16 to Interface B and determine the delay <math>D_{JB2}</math></li> <li>• Apply signal C16 to Interface A and determine the delay <math>D_{JB1}</math></li> <li>• Establishing a new call from B to A and reset De-jitter buffer 1 and De-jitter buffer 2</li> <li>• Apply signal ANS to Interface A</li> <li>• Apply signal C16 to Interface B and determine the delay <math>D_{JB1}</math> after sending ANS (from A)</li> <li>• Apply signal C16 to Interface A and determine the delay <math>D_{JB2}</math> after sending ANS (from A)</li> </ul>
<b>Requirement</b>	<p>I)</p> <ol style="list-style-type: none"> <li>a) First call; <math>D_{JB1} = D_{JB2}</math> Delay for De-jitter buffer Adaptive</li> <li>b) Second call; <math>D_{JB1} = D_{JB2}</math> Delay for De-jitter buffer Fixed</li> </ol> <p>II)</p> <ol style="list-style-type: none"> <li>a) First call; <math>D_{JB1} = D_{JB2}</math> Delay for De-jitter buffer Adaptive</li> <li>b) Second call; <math>D_{JB1} = D_{JB2}</math> Delay for De-jitter buffer Fixed</li> </ol>
<b>FAX test sequences: Calling tone (CNG) Conditions</b>	
<b>Called station identification (CED) Conditions</b>	<p>CED (ANS) 2 100 Hz <math>\pm</math> 15 Hz sine (Recommendation ITU-T V.25 [6])  Duration 3 s  (Recommendation ITU-T G.168 [3], clause 6.4.2.11 Test No. 10 - Facsimile test)  The amplitude of the tone is <b>-12 dBm0</b></p>

<b>Test number:</b>	<b>1.1.2 FAX</b>
<b>Transmission Type:</b>	Facsimile with <b>ANS</b> /-31 dBm0
<b>Measurement procedure</b>	<p>A)</p> <ul style="list-style-type: none"> <li>• Establishing a new call from A to B and reset De-jitter buffer 1 and De-jitter buffer 2</li> <li>• Apply signal C16 to Interface A and determine the delay <math>D_{JB1}</math></li> <li>• Apply signal C16 to Interface B and determine the delay <math>D_{JB2}</math></li> <li>• Establishing a new call from A to B and reset De-jitter buffer 1 and Jitter Buffer 2</li> <li>• Apply signal ANS to Interface B</li> <li>• Apply signal C16 to Interface A and determine the delay <math>D_{JB1}</math> after sending ANS (from B)</li> <li>• Apply signal C16 to Interface B and determine the delay <math>D_{JB2}</math> after sending ANS (from B)</li> </ul> <p>B)</p> <ul style="list-style-type: none"> <li>• Establishing a new call from B to A and reset De-jitter buffer 1 and De-jitter buffer 2</li> <li>• Apply signal C16 to Interface B and determine the delay <math>D_{JB2}</math></li> <li>• Apply signal C16 to Interface A and determine the delay <math>D_{JB1}</math></li> <li>• Establishing a new call from B to A and reset De-jitter buffer 1 and De-jitter buffer 2</li> <li>• Apply signal ANS to Interface A</li> <li>• Apply signal C16 to Interface B and determine the delay <math>D_{JB1}</math> after sending ANS (from A)</li> <li>• Apply signal C16 to Interface A and determine the delay <math>D_{JB2}</math> after sending ANS (from A)</li> </ul>
<b>Requirement</b>	<p>I)</p> <ul style="list-style-type: none"> <li>a) First call; <math>D_{JB1} = D_{JB2}</math> Delay for De-jitter buffer Adaptive</li> <li>b) Second call; <math>D_{JB1} = D_{JB2}</math> for Delay for De-jitter buffer Fixed</li> </ul> <p>II)</p> <ul style="list-style-type: none"> <li>a) First call; <math>D_{JB1} = D_{JB2}</math> Delay for De-jitter buffer Adaptive</li> <li>b) Second call; <math>D_{JB1} = D_{JB2}</math> for Delay for De-jitter buffer Fixed</li> </ul>
<b>FAX test sequences: Calling tone (CNG) Conditions</b>	
<b>Called station identification (CED) Conditions</b>	<p>CED (ANS) 2 100 Hz <math>\pm</math> 15 Hz sine (Recommendation ITU-T V.25 [6]) Duration 3 s (Recommendation ITU-T G.168 [3], clause 6.4.2.11 Test No. 10 - Facsimile test) The amplitude of the tone is <b>-31 dBm0</b></p>

<b>Test number:</b>	<b>1.2.1 FAX</b>
<b>Transmission Type:</b>	Facsimile with early VBD detection with CNG/-12 dBm0
<b>Measurement procedure</b>	<p>I)</p> <ul style="list-style-type: none"> <li>• Establishing a new call from A to B and reset De-jitter buffer 1 and De-jitter buffer 2</li> <li>• Apply signal C16 to Interface A and determine the delay <math>D_{JB1}</math></li> <li>• Apply signal C16 to Interface B and determine the delay <math>D_{JB2}</math></li> <li>• Establishing a new call from A to B and reset De-jitter buffer 1 and De-jitter buffer 2</li> <li>• Apply signal CNG to Interface A</li> <li>• Apply signal C16 to Interface A and determine the delay <math>D_{JB1}</math> after sending CNG from A</li> <li>• Apply signal C16 to Interface B and determine the delay <math>D_{JB2}</math> after sending CNG from A</li> </ul> <p>II)</p> <ul style="list-style-type: none"> <li>• Establishing a new call from B to A and reset De-jitter buffer 1 and De-jitter buffer 2</li> <li>• Apply signal C16 to Interface B and determine the delay <math>D_{JB2}</math></li> <li>• Apply signal C16 to Interface A and determine the delay <math>D_{JB1}</math></li> <li>• Establishing a new call from B to A and reset De-jitter buffer 1 and De-jitter buffer 2</li> <li>• Apply signal CNG to Interface B</li> <li>• Apply signal C16 to Interface B and determine the delay <math>D_{JB1}</math> after sending CNG from B</li> <li>• Apply signal C16 to Interface A and determine the delay <math>D_{JB2}</math> after sending CNG from B</li> </ul>
<b>Requirement</b>	<p>I)</p> <p>a) First call; <math>D_{JB1} = D_{JB2}</math> Delay for De-jitter buffer Adaptive  b) Second call; <math>D_{JB1} = D_{JB2}</math> for Delay for De-jitter buffer Fixed</p> <p>II)</p> <p>a) First call; <math>D_{JB1} = D_{JB2}</math> Delay for De-jitter buffer Adaptive  b) Second call; <math>D_{JB1} = D_{JB2}</math> for Delay for De-jitter buffer Fixed</p>
<b>FAX test sequences: Calling tone (CNG) Conditions</b>	
<b>Called station identification (CED) Conditions</b>	<p>CED (ANS) 2 100 Hz <math>\pm</math> 15 Hz sine (Recommendation ITU-T V.25 [6])  Duration 3 s  (Recommendation ITU-T G.168 [3], clause 6.4.2.11 Test No. 10 - Facsimile test)  The amplitude of the tone is <b>-12 dBm0</b></p>

<b>Test number:</b>	<b>1.2.2 FAX</b>
<b>Transmission Type:</b>	Facsimile with early VBD detection with CNG/-31 dBm0
<b>Measurement procedure</b>	<p>I)</p> <ul style="list-style-type: none"> <li>• Establishing a new call from A to B and reset De-jitter buffer 1 and De-jitter buffer 2</li> <li>• Apply signal C16 to Interface A and determine the delay <math>D_{JB1}</math></li> <li>• Apply signal C16 to Interface B and determine the delay <math>D_{JB2}</math></li> <li>• Establishing a new call from A to B and reset De-jitter buffer 1 and De-jitter buffer 2</li> <li>• Apply signal CNG to Interface A</li> <li>• Apply signal C16 to Interface A and determine the delay <math>D_{JB1}</math> after sending CNG from A</li> <li>• Apply signal C16 to Interface B and determine the delay <math>D_{JB2}</math> after sending CNG from A</li> </ul> <p>II)</p> <ul style="list-style-type: none"> <li>• Establishing a new call from B to A and reset De-jitter buffer 1 and De-jitter buffer 2</li> <li>• Apply signal C16 to Interface B and determine the delay <math>D_{JB2}</math></li> <li>• Apply signal C16 to Interface A and determine the delay <math>D_{JB1}</math></li> <li>• Establishing a new call from B to A and reset De-jitter buffer 1 and De-jitter buffer 2</li> <li>• Apply signal CNG to Interface B</li> <li>• Apply signal C16 to Interface B and determine the delay <math>D_{JB1}</math> after sending CNG from B</li> <li>• Apply signal C16 to Interface A and determine the delay <math>D_{JB2}</math> after sending CNG from B</li> </ul>
<b>Requirement</b>	<p>I)</p> <p>a) First call; <math>D_{JB1} = D_{JB2}</math> Delay for De-jitter buffer Adaptive  b) Second Call; <math>D_{JB1} = D_{JB2}</math> for Delay for De-jitter buffer Fixed</p> <p>II)</p> <p>a) First call; <math>D_{JB1} = D_{JB2}</math> Delay jitter for Voice  b) Second call; <math>D_{JB1} = D_{JB2}</math> for Delay for De-jitter buffer Fixed</p>
<b>FAX test sequences: Calling tone (CNG) Conditions</b>	
<b>Called station identification (CED) Conditions</b>	<p>CED (ANS) 2 100 Hz <math>\pm</math> 15 Hz sine (Recommendation ITU-T V.25 [6])  Duration 3 s  (Recommendation ITU-T G.168 [3], clause 6.4.2.11 Test No. 10 - Facsimile test)  The amplitude of the tone is <b>-31 dBm0</b></p>

<b>Test number:</b>	<b>1.3.1 FAX</b>
<b>Transmission Type:</b>	Facsimile with V.17 data transmission with ANS/-12 dBm0
<b>Measurement procedure</b>	<p>I)</p> <ul style="list-style-type: none"> <li>• Establishing a new call from A to B and reset De-jitter buffer 1 and De-jitter buffer 2</li> <li>• Apply signal C16 to Interface A and determine the delay <math>D_{JB1}</math></li> <li>• Apply signal C16 to Interface B and determine the delay <math>D_{JB2}</math></li> <li>• Establishing a new call from A to B and reset De-jitter buffer 1 and De-jitter buffer 2</li> <li>• Apply signal CNG to Interface A</li> <li>• Apply signal ANS to Interface B</li> <li>• Apply transmission of FAX</li> <li>• Apply signal C16 to Interface A and determine the delay <math>D_{JB1}</math> after transmission of FAX</li> <li>• Apply signal C16 to Interface B and determine the delay <math>D_{JB2}</math> after sending FAX</li> </ul> <p>II)</p> <ul style="list-style-type: none"> <li>• Establishing a new call from B to A and reset De-jitter buffer 1 and De-jitter buffer 2</li> <li>• Apply signal C16 to Interface B and determine the delay <math>D_{JB2}</math></li> <li>• Apply signal C16 to Interface A and determine the delay <math>D_{JB1}</math></li> <li>• Establishing a new call from B to A and reset De-jitter buffer 1 and De-jitter buffer 2</li> <li>• Apply signal CNG to Interface B</li> <li>• Apply signal ANS to Interface A</li> <li>• Apply transmission of FAX</li> <li>• Apply signal C16 to Interface B and determine the delay <math>D_{JB1}</math> after transmission of FAX from B</li> <li>• Apply signal C16 to Interface A and determine the delay <math>D_{JB2}</math> after transmission of FAX</li> <li>• The transmission of the signal C16 shall be without time interruption after the transmission of the FAX transmission</li> </ul>
<b>Requirement</b>	<p>I)</p> <ol style="list-style-type: none"> <li>a) First call; <math>D_{JB1} = D_{JB2}</math> Delay for De-jitter buffer Adaptive</li> <li>b) Second call; <math>D_{JB1} = D_{JB2}</math> for Delay for De-jitter buffer Fixed</li> </ol> <p>II)</p> <ol style="list-style-type: none"> <li>a) First call; <math>D_{JB1} = D_{JB2}</math> Delay jitter for Voice</li> <li>b) Second call; <math>D_{JB1} = D_{JB2}</math> for Delay for De-jitter buffer Fixed</li> </ol>
<b>FAX test sequences: Calling tone (CNG) Conditions</b>	
<b>Called station identification (CED) Conditions</b>	<p>CED (ANS) 2 100 Hz <math>\pm</math> 15 Hz sine (Recommendation ITU-T V.25 [6]) Duration 3 s (Recommendation ITU-T G.168 [3], clause 6.4.2.11 Test No. 10 - Facsimile test) The amplitude of the tone is <b>-12 dBm0</b></p>



<b>Test number:</b>	<b>1.3.2 FAX</b>
<b>Transmission Type:</b>	Facsimile with V.17 data transmission with ANS/-31 dBm0
<b>Measurement procedure</b>	<p>I)</p> <ul style="list-style-type: none"> <li>• Establishing a new call from A to B and reset De-jitter buffer 1 and De-jitter buffer 2</li> <li>• Apply signal C16 to Interface A and determine the delay <math>D_{JB1}</math></li> <li>• Apply signal C16 to Interface B and determine the delay <math>D_{JB2}</math></li> <li>• Establishing a new call from A to B and reset De-jitter buffer 1 and De-jitter buffer 2</li> <li>• Apply signal CNG to Interface A</li> <li>• Apply signal ANS to Interface B</li> <li>• Apply transmission of FAX</li> <li>• Apply signal C16 to Interface A and determine the delay <math>D_{JB1}</math> after transmission of FAX</li> <li>• Apply signal C16 to Interface B and determine the delay <math>D_{JB2}</math> after sending FAX</li> </ul> <p>II)</p> <ul style="list-style-type: none"> <li>• Establishing a new call from B to A and reset De-jitter buffer 1 and De-jitter buffer 2</li> <li>• Apply signal C16 to Interface B and determine the delay <math>D_{JB2}</math></li> <li>• Apply signal C16 to Interface A and determine the delay <math>D_{JB1}</math></li> <li>• Establishing a new call from B to A and reset De-jitter buffer 1 and De-jitter buffer 2</li> <li>• Apply signal CNG to Interface B</li> <li>• Apply signal ANS to Interface A</li> <li>• Apply transmission of FAX</li> <li>• Apply signal C16 to Interface B and determine the delay <math>D_{JB1}</math> after transmission of FAX from B</li> <li>• Apply signal C16 to Interface A and determine the delay <math>D_{JB2}</math> after transmission of FAX</li> <li>• The transmission of the signal C16 shall be without time interruption after the transmission of the FAX transmission</li> </ul>
<b>Requirement</b>	<p>I)</p> <ul style="list-style-type: none"> <li>a) First call; <math>D_{JB1} = D_{JB2}</math> Delay for De-jitter buffer Adaptive</li> <li>b) Second call; <math>D_{JB1} = D_{JB2}</math> for Delay for De-jitter buffer Fixed</li> </ul> <p>II)</p> <ul style="list-style-type: none"> <li>a) First call; <math>D_{JB1} = D_{JB2}</math> Delay jitter for Voice</li> <li>b) Second call; <math>D_{JB1} = D_{JB2}</math> for Delay for De-jitter buffer Fixed</li> </ul>
<b>FAX test sequences: Calling tone (CNG) Conditions</b>	
<b>Called station identification (CED) Conditions</b>	<p>CED (ANS) 2 100 Hz <math>\pm</math> 15 Hz sine (Recommendation ITU-T V.25 [6]) Duration 3 s (Recommendation ITU-T G.168 [3], clause 6.4.2.11 Test No. 10 - Facsimile test) The amplitude of the tone is <b>-31 dBm0</b></p>

<b>Test number:</b>	<b>1.4.1_FAX</b>
<b>Transmission Type:</b>	Facsimile with /ANS/-12 dBm0
<b>Measurement procedure</b>	<p>I)</p> <ul style="list-style-type: none"> <li>• Establishing a new call from A to B and reset De-jitter buffer 1 and De-jitter buffer 2</li> <li>• Apply signal C16 to Interface A and determine the delay <math>D_{JB1}</math></li> <li>• Apply signal C16 to Interface B and determine the delay <math>D_{JB2}</math></li> <li>• Establishing a new call from A to B and reset De-jitter buffer 1 and De-jitter buffer 2</li> <li>• Apply signal/ANS to Interface B</li> <li>• Apply signal C16 to Interface A and determine the delay <math>D_{JB1}</math> after sending/ANS (from B)</li> <li>• Apply signal C16 to Interface B and determine the delay <math>D_{JB2}</math> after sending/ANS (from B)</li> </ul> <p>II)</p> <ul style="list-style-type: none"> <li>• Establishing a new call from B to A and reset De-jitter buffer 1 and De-jitter buffer 2</li> <li>• Apply signal C16 to Interface B and determine the delay <math>D_{JB2}</math></li> <li>• Apply signal C16 to Interface A and determine the delay <math>D_{JB1}</math></li> <li>• Establishing a new call from B to A and reset De-jitter buffer 1 and De-jitter buffer 2</li> <li>• Apply signal/ANS to Interface A</li> <li>• Apply signal C16 to Interface B and determine the delay <math>D_{JB1}</math> after sending/ANS (from A)</li> <li>• Apply signal C16 to Interface A and determine the delay <math>D_{JB2}</math> after sending ANS (from A)</li> </ul>
<b>Requirement</b>	<p>I)</p> <p>a) First call; <math>D_{JB1} = D_{JB2}</math> Delay for De-jitter buffer Adaptive  b) <math>D_{JB1} = D_{JB2}</math> for Delay for De-jitter buffer Fixed</p> <p>II)</p> <p>a) First call; <math>D_{JB1} = D_{JB2}</math> Delay for De-jitter buffer Adaptive  b) Second call; <math>D_{JB1} = D_{JB2}</math> for Delay for De-jitter buffer Fixed</p>
<b>FAX test sequences: Calling tone (CNG) Conditions</b>	
<b>Called station identification (CED) Conditions</b>	/ANS - 2 100 Hz $\pm$ 15 Hz sine (Recommendation ITU-T V.25 [6]) with 180° phase shift every 450 ms (Recommendation ITU-T V.25 [6]) Duration 3 s The amplitude of the tone is <b>-12 dBm0</b>

<b>Test number:</b>	<b>1.4.2_FAX</b>
<b>Transmission Type:</b>	Facsimile with /ANS/-31 dBm0
<b>Measurement procedure</b>	<p>I)</p> <ul style="list-style-type: none"> <li>• Establishing a new call from A to B and reset De-jitter buffer 1 and De-jitter buffer 2</li> <li>• Apply signal C16 to Interface A and determine the delay <math>D_{JB1}</math></li> <li>• Apply signal C16 to Interface B and determine the delay <math>D_{JB2}</math></li> <li>• Establishing a new call from A to B and reset De-jitter buffer 1 and De-jitter buffer 2</li> <li>• Apply signal/ANS to Interface B</li> <li>• Apply signal C16 to Interface A and determine the delay <math>D_{JB1}</math> after sending/ANS (from B)</li> <li>• Apply signal C16 to Interface B and determine the delay <math>D_{JB2}</math> after sending/ANS (from B)</li> </ul> <p>II)</p> <ul style="list-style-type: none"> <li>• Establishing a new call from B to A and reset De-jitter buffer 1 and De-jitter buffer 2</li> <li>• Apply signal C16 to Interface B and determine the delay <math>D_{JB2}</math></li> <li>• Apply signal C16 to Interface A and determine the delay <math>D_{JB1}</math></li> <li>• Establishing a new call from B to A and reset De-jitter buffer 1 and De-jitter buffer 2</li> <li>• Apply signal/ANS to Interface A</li> <li>• Apply signal C16 to Interface B and determine the delay <math>D_{JB1}</math> after sending/ANS (from A)</li> <li>• Apply signal C16 to Interface A and determine the delay <math>D_{JB2}</math> after sending ANS (from A)</li> </ul>
<b>Requirement</b>	<p>I)</p> <ul style="list-style-type: none"> <li>a) First call; <math>D_{JB1} = D_{JB2}</math> Delay for De-jitter buffer Adaptive</li> <li>b) Second call; <math>D_{JB1} = D_{JB2}</math> for Delay for De-jitter buffer Fixed</li> </ul> <p>II)</p> <ul style="list-style-type: none"> <li>a) First call; <math>D_{JB1} = D_{JB2}</math> Delay for De-jitter buffer Adaptive</li> <li>b) Second call; <math>D_{JB1} = D_{JB2}</math> for Delay for De-jitter buffer Fixed</li> </ul>
<b>FAX test sequences: Calling tone (CNG) Conditions</b>	
<b>Called station identification (CED) Conditions</b>	/ANS 2 100 Hz $\pm$ 15 Hz sine (Recommendation ITU-T V.25 [6]) with 180° phase shift every 450 ms (Recommendation ITU-T V.25 [6]) Duration 3 s The amplitude of the tone is <b>-31 dBm0</b>

<b>Test number:</b>	<b>1.5.1_FAX</b>
<b>Transmission Type:</b>	Facsimile with V.34 data transmission with /ANS/-12 dBm0
<b>Measurement procedure</b>	<p>I)</p> <ul style="list-style-type: none"> <li>• Establishing a new call from A to B and reset De-jitter buffer 1 and De-jitter buffer 2</li> <li>• Apply signal C16 to Interface A and determine the delay <math>D_{JB1}</math></li> <li>• Apply signal C16 to Interface B and determine the delay <math>D_{JB2}</math></li> <li>• Apply signal/ANS to Interface B</li> <li>• Establishing a new call from A to B and reset De-jitter buffer 1 and De-jitter buffer 2</li> <li>• Apply transmission of FAX</li> <li>• Apply signal C16 to Interface A and determine the delay <math>D_{JB1}</math> after sending FAX from interface A</li> <li>• Apply signal C16 to Interface B and determine the delay <math>D_{JB2}</math> after sending FAX from interface A</li> </ul> <p>II)</p> <ul style="list-style-type: none"> <li>• Establishing a new call from B to A and reset De-jitter buffer 1 and De-jitter buffer 2</li> <li>• Apply signal C16 to Interface B and determine the delay <math>D_{JB2}</math></li> <li>• Apply signal C16 to Interface A and determine the delay <math>D_{JB1}</math></li> <li>• Establishing a new call from B to A and reset De-jitter buffer 1 and De-jitter buffer 2</li> <li>• Apply signal/ANS to Interface A</li> <li>• Apply transmission of FAX</li> <li>• Apply signal C16 to Interface B and determine the delay <math>D_{JB1}</math> after sending FAX from B</li> <li>• Apply signal C16 to Interface A and determine the delay <math>D_{JB2}</math> after sending FAX from B</li> </ul>
<b>Requirement</b>	<p>I)</p> <ul style="list-style-type: none"> <li>a) First call; <math>D_{JB1} = D_{JB2}</math> Delay for De-jitter buffer Adaptive</li> <li>b) Second call; <math>D_{JB1} = D_{JB2}</math> for Delay for De-jitter buffer Fixed</li> </ul> <p>II)</p> <ul style="list-style-type: none"> <li>a) First call; <math>D_{JB1} = D_{JB2}</math> Delay for De-jitter buffer Adaptive</li> <li>b) Second call; <math>D_{JB1} = D_{JB2}</math> for Delay for De-jitter buffer Fixed</li> </ul>
<b>FAX test sequences: Calling tone (CNG) Conditions</b>	
<b>Called station identification (CED) Conditions</b>	/ANS 2 100 Hz $\pm$ 15 Hz sine (Recommendation ITU-T V.25 [6]) with 180° phase shift every 450 ms (Recommendation ITU-T V.25 [6]) Duration 3 s The amplitude of the tone is <b>-12 dBm0</b>

<b>Test number:</b>	<b>1.5.2_FAX</b>
<b>Transmission Type:</b>	Facsimile with V.34 data transmission with /ANS/-31 dBm0
<b>Measurement procedure</b>	<p>I)</p> <ul style="list-style-type: none"> <li>• Establishing a new call from A to B and reset De-jitter buffer 1 and De-jitter buffer 2</li> <li>• Apply signal C16 to Interface A and determine the delay <math>D_{JB1}</math></li> <li>• Apply signal C16 to Interface B and determine the delay <math>D_{JB2}</math></li> <li>• Apply signal/ANS to Interface B</li> <li>• Establishing a new call from A to B and reset De-jitter buffer 1 and De-jitter buffer 2</li> <li>• Apply transmission of FAX</li> <li>• Apply signal C16 to Interface A and determine the delay <math>D_{JB1}</math> after sending FAX from interface A</li> <li>• Apply signal C16 to Interface B and determine the delay <math>D_{JB2}</math> after sending FAX from interface A</li> </ul> <p>II)</p> <ul style="list-style-type: none"> <li>• Establishing a new call from B to A and reset De-jitter buffer 1 and De-jitter buffer 2</li> <li>• Apply signal C16 to Interface B and determine the delay <math>D_{JB2}</math></li> <li>• Apply signal C16 to Interface A and determine the delay <math>D_{JB1}</math></li> <li>• Establishing a new call from B to A and reset De-jitter buffer 1 and De-jitter buffer 2</li> <li>• Apply signal/ANS to Interface A</li> <li>• Apply transmission of FAX</li> <li>• Apply signal C16 to Interface B and determine the delay <math>D_{JB1}</math> after sending FAX from B</li> <li>• Apply signal C16 to Interface A and determine the delay <math>D_{JB2}</math> after sending FAX from B</li> </ul>
<b>Requirement</b>	<p>I)</p> <ul style="list-style-type: none"> <li>a) First call; <math>D_{JB1} = D_{JB2}</math> Delay for De-jitter buffer Adaptive</li> <li>b) Second call; <math>D_{JB1} = D_{JB2}</math> for Delay for De-jitter buffer Fixed</li> </ul> <p>II)</p> <ul style="list-style-type: none"> <li>a) First call; <math>D_{JB1} = D_{JB2}</math> Delay for De-jitter buffer Adaptive</li> <li>b) Second call; <math>D_{JB1} = D_{JB2}</math> for Delay for De-jitter buffer Fixed</li> </ul>
<b>FAX test sequences: Calling tone (CNG) Conditions</b>	
<b>Called station identification (CED) Conditions</b>	/ANS 2 100 Hz $\pm$ 15 Hz sine (Recommendation ITU-T V.25 [6]) with 180° phase shift every 450 ms (Recommendation ITU-T V.25 [6]) Duration 3 s The amplitude of the tone is <b>-31 dBm0</b>

<b>Test number:</b>	<b>1.6.1_FAX</b>
<b>Transmission Type:</b>	Facsimile with /ANSam/-12 dBm0
<b>Measurement procedure</b>	<p>I)</p> <ul style="list-style-type: none"> <li>• Establishing a new call from A to B and reset De-jitter buffer 1 and De-jitter buffer 2</li> <li>• Apply signal C16 to Interface A and determine the delay <math>D_{JB1}</math></li> <li>• Apply signal C16 to Interface B and determine the delay <math>D_{JB2}</math></li> <li>• Establishing a new call from A to B and reset De-jitter buffer 1 and De-jitter buffer 2</li> <li>• Apply signal/ANSam to Interface B</li> <li>• Apply signal C16 to Interface A and determine the delay <math>D_{JB1}</math> after sending/ANSam (from B)</li> <li>• Apply signal C16 to Interface B and determine the delay <math>D_{JB2}</math> after sending/ANSam (from B)</li> </ul> <p>II)</p> <ul style="list-style-type: none"> <li>• Establishing a new call from B to A and reset De-jitter buffer 1 and De-jitter buffer 2</li> <li>• Apply signal C16 to Interface B and determine the delay <math>D_{JB2}</math></li> <li>• Apply signal C16 to Interface A and determine the delay <math>D_{JB1}</math></li> <li>• Establishing a new call from B to A and reset De-jitter buffer 1 and De-jitter buffer 2</li> <li>• Apply signal/ANSam to Interface A</li> <li>• Apply signal C16 to Interface B and determine the delay <math>D_{JB1}</math> after sending/ANSam (from A)</li> <li>• Apply signal C16 to Interface A and determine the delay <math>D_{JB2}</math> after sending/ANSam (from A)</li> </ul>
<b>Requirement</b>	<p>I)</p> <p>a) First call; <math>D_{JB1} = D_{JB2}</math> Delay for De-jitter buffer Adaptive  b) Second call; <math>D_{JB1} = D_{JB2}</math> for Delay for De-jitter buffer Fixed</p> <p>II)</p> <p>a) First call; <math>D_{JB1} = D_{JB2}</math> Delay for De-jitter buffer Adaptive  b) Second call; <math>D_{JB1} = D_{JB2}</math> for Delay for De-jitter buffer Fixed</p>
<b>FAX test sequences: Calling tone (CNG) Conditions</b>	
<b>Called station identification (CED) Conditions</b>	/ANSam - 2 100 Hz $\pm$ 15 Hz sine (Recommendation ITU-T V.25 [6]) 2 100 Hz amplitude-modulated by a sinewave at 15 Hz with phase reversals at an interval of $450 \pm 25$ ms Duration 3 s The amplitude of the tone is <b>-12 dBm0</b>

<b>Test number:</b>	<b>1.6.2_FAX</b>
<b>Transmission Type:</b>	Facsimile with /ANSam/-31 dBm0
<b>Measurement procedure</b>	<p>I)</p> <ul style="list-style-type: none"> <li>• Establishing a new call from A to B and reset De-jitter buffer 1 and De-jitter buffer 2</li> <li>• Apply signal C16 to Interface A and determine the delay <math>D_{JB1}</math></li> <li>• Apply signal C16 to Interface B and determine the delay <math>D_{JB2}</math></li> <li>• Establishing a new call from A to B and reset De-jitter buffer 1 and De-jitter buffer 2</li> <li>• Apply signal/ANSam to Interface B</li> <li>• Apply signal C16 to Interface A and determine the delay <math>D_{JB1}</math> after sending/ANSam (from B)</li> <li>• Apply signal C16 to Interface B and determine the delay <math>D_{JB2}</math> after sending/ANSam (from B)</li> </ul> <p>II)</p> <ul style="list-style-type: none"> <li>• Establishing a new call from B to A and reset De-jitter buffer 1 and De-jitter buffer 2</li> <li>• Apply signal C16 to Interface B and determine the delay <math>D_{JB2}</math></li> <li>• Apply signal C16 to Interface A and determine the delay <math>D_{JB1}</math></li> <li>• Establishing a new call from B to A and reset De-jitter buffer 1 and De-jitter buffer 2</li> <li>• Apply signal/ANSam to Interface A</li> <li>• Apply signal C16 to Interface B and determine the delay <math>D_{JB1}</math> after sending/ANSam (from A)</li> <li>• Apply signal C16 to Interface A and determine the delay <math>D_{JB2}</math> after sending/ANSam (from A)</li> </ul>
<b>Requirement</b>	<p>I)</p> <p>a) First call; <math>D_{JB1} = D_{JB2}</math> Delay for De-jitter buffer Adaptive  b) Second call; <math>D_{JB1} = D_{JB2}</math> for Delay for De-jitter buffer Fixed</p> <p>II)</p> <p>a) First call; <math>D_{JB1} = D_{JB2}</math> Delay for De-jitter buffer Adaptive  b) Second call; <math>D_{JB1} = D_{JB2}</math> for Delay for De-jitter buffer Fixed</p>
<b>FAX test sequences: Calling tone (CNG) Conditions</b>	
<b>Called station identification (CED) Conditions</b>	/ANSam 2 100 Hz $\pm$ 15 Hz sine (Recommendation ITU-T V.25 [6]) 2 100 Hz amplitude-modulated by a sinewave at 15 Hz with phase reversals at an interval of $450 \pm 25$ ms Duration 3 s The amplitude of the tone is <b>-31 dBm0</b>

<b>Test number:</b>	<b>1.7.1_FAX</b>
<b>Transmission Type:</b>	Facsimile with V.34 data transmission with /ANSam/-12 dBm0
<b>Measurement procedure</b>	<p>I)</p> <ul style="list-style-type: none"> <li>• Establishing a new call from A to B and reset De-jitter buffer 1 and De-jitter buffer 2</li> <li>• Apply signal C16 to Interface A and determine the delay <math>D_{JB1}</math></li> <li>• Apply signal C16 to Interface B and determine the delay <math>D_{JB2}</math></li> <li>• Establishing a new call from A to B and reset De-jitter buffer 1 and De-jitter buffer 2</li> <li>• Apply signal/ANSam to Interface B</li> <li>• Apply transmission of FAX</li> <li>• Apply signal C16 to Interface A and determine the delay <math>D_{JB1}</math> after sending/ANSam (from B) + fax transmission</li> <li>• Apply signal C16 to Interface B and determine the delay <math>D_{JB2}</math> after sending/ANSam (from B) + fax transmission</li> </ul> <p>II)</p> <ul style="list-style-type: none"> <li>• Establishing a new call from B to A and reset De-jitter buffer 1 and De-jitter buffer 2</li> <li>• Apply signal C16 to Interface B and determine the delay <math>D_{JB2}</math></li> <li>• Apply signal C16 to Interface A and determine the delay <math>D_{JB1}</math></li> <li>• Establishing a new call from B to A and reset De-jitter buffer 1 and De-jitter buffer 2</li> <li>• Apply signal/ANSam to Interface A</li> <li>• Apply transmission of FAX</li> <li>• Apply signal C16 to Interface B and determine the delay <math>D_{JB1}</math> after sending fax transmission</li> <li>• Apply signal C16 to Interface A and determine the delay <math>D_{JB2}</math> after fax transmission</li> </ul>
<b>Requirement</b>	<p>I)</p> <p>a) First call; <math>D_{JB1} = D_{JB2}</math> Delay for De-jitter buffer Adaptive</p> <p>b) Second call; <math>D_{JB1} = D_{JB2}</math> for Delay for De-jitter buffer Fixed</p> <p>II)</p> <p>a) First call; <math>D_{JB1} = D_{JB2}</math> Delay for De-jitter buffer Adaptive</p> <p>b) Second call; <math>D_{JB1} = D_{JB2}</math> for Delay for De-jitter buffer Fixed</p>
<b>FAX test sequences: Calling tone (CNG) Conditions</b>	
<b>Called station identification (CED) Conditions</b>	/ANSam 2 100 Hz $\pm$ 15 Hz sine (Recommendation ITU-T V.25 [6]) 2 100 Hz amplitude-modulated by a sinewave at 15 Hz with phase reversals at an interval of $450 \pm 25$ ms Duration 3 s The amplitude of the tone is <b>-12 dBm0</b>



<b>Test number:</b>	<b>1.7.2_FAX</b>
<b>Transmission Type:</b>	Facsimile with V.34 data transmission with /ANSam/-31 dBm0
<b>Measurement procedure</b>	<p>I)</p> <ul style="list-style-type: none"> <li>• Establishing a new call from A to B and reset De-jitter buffer 1 and De-jitter buffer 2</li> <li>• Apply signal C16 to Interface A and determine the delay <math>D_{JB1}</math></li> <li>• Apply signal C16 to Interface B and determine the delay <math>D_{JB2}</math></li> <li>• Establishing a new call from A to B and reset De-jitter buffer 1 and De-jitter buffer 2</li> <li>• Apply signal/ANSam to Interface B</li> <li>• Apply transmission of FAX</li> <li>• Apply signal C16 to Interface A and determine the delay <math>D_{JB1}</math> after sending/ANSam (from B) + fax transmission</li> <li>• Apply signal C16 to Interface B and determine the delay <math>D_{JB2}</math> after sending/ANSam (from B) + fax transmission</li> </ul> <p>II)</p> <ul style="list-style-type: none"> <li>• Establishing a new call from B to A and reset De-jitter buffer 1 and De-jitter buffer 2</li> <li>• Apply signal C16 to Interface B and determine the delay <math>D_{JB2}</math></li> <li>• Apply signal C16 to Interface A and determine the delay <math>D_{JB1}</math></li> <li>• Establishing a new call from B to A and reset De-jitter buffer 1 and De-jitter buffer 2</li> <li>• Apply signal/ANSam to Interface A</li> <li>• Apply transmission of FAX</li> <li>• Apply signal C16 to Interface B and determine the delay <math>D_{JB1}</math> after sending fax transmission</li> <li>• Apply signal C16 to Interface A and determine the delay <math>D_{JB2}</math> after fax transmission</li> </ul>
<b>Requirement</b>	<p>I)</p> <ol style="list-style-type: none"> <li>a) First call; <math>D_{JB1} = D_{JB2}</math> Delay for De-jitter buffer Adaptive</li> <li>b) Second call; <math>D_{JB1} = D_{JB2}</math> for Delay for De-jitter buffer Fixed</li> </ol> <p>II)</p> <ol style="list-style-type: none"> <li>a) First call; <math>D_{JB1} = D_{JB2}</math> Delay for De-jitter buffer Adaptive</li> <li>b) Second call; <math>D_{JB1} = D_{JB2}</math> for Delay for De-jitter buffer Fixed</li> </ol>
<b>FAX test sequences: Calling tone (CNG) Conditions</b>	
<b>Called station identification (CED) Conditions</b>	/ANSam 2 100 Hz $\pm$ 15 Hz sine (Recommendation ITU-T V.25 [6]) 2 100 Hz amplitude-modulated by a sinewave at 15 Hz with phase reversals at an interval of $450 \pm 25$ ms Duration 3 s The amplitude of the tone is <b>-31 dBm0</b>

## De-jitter buffer Modem tests

<b>Test number:</b>	<b>2.1.1 MODEM</b>
<b>Transmission Type:</b>	Modem with ANS/-12 dBm0
<b>Measurement procedure</b>	<p>I)</p> <ul style="list-style-type: none"> <li>• Establishing a new call from A to B and reset De-jitter buffer 1 and De-jitter buffer 2</li> <li>• Apply signal C16 to Interface A and determine the delay <math>D_{JB1}</math></li> <li>• Apply signal C16 to Interface B and determine the delay <math>D_{JB2}</math></li> <li>• Establishing a new call from A to B and reset De-jitter buffer 1 and De-jitter buffer 2</li> <li>• Apply signal ANS to Interface B</li> <li>• Apply signal C16 to Interface A and determine the delay <math>D_{JB1}</math> after sending ANS (from B)</li> <li>• Apply signal C16 to Interface B and determine the delay <math>D_{JB2}</math> after sending ANS (from B)</li> </ul> <p>II)</p> <ul style="list-style-type: none"> <li>• Establishing a new call from B to A and reset De-jitter buffer 1 and De-jitter buffer 2</li> <li>• Apply signal C16 to Interface B and determine the delay <math>D_{JB2}</math></li> <li>• Apply signal C16 to Interface A and determine the delay <math>D_{JB1}</math></li> <li>• Establishing a new call from B to A and reset De-jitter buffer 1 and De-jitter buffer 2</li> <li>• Apply signal ANS to Interface A</li> <li>• Apply signal C16 to Interface B and determine the delay <math>D_{JB1}</math> after sending ANS (from A)</li> <li>• Apply signal C16 to Interface A and determine the delay <math>D_{JB2}</math> after sending ANS (from A)</li> </ul>
<b>Requirement</b>	<p>I)</p> <p>a) First call; <math>D_{JB1} = D_{JB2}</math> Delay for De-jitter buffer Adaptive</p> <p>b) Second call; <math>D_{JB1} = D_{JB2}</math> for Delay for De-jitter buffer Fixed</p> <p>II)</p> <p>a) First call; <math>D_{JB1} = D_{JB2}</math> Delay for De-jitter buffer Adaptive</p> <p>b) Second call; <math>D_{JB1} = D_{JB2}</math> for Delay for De-jitter buffer Fixed</p>
<b>Modem test sequences:</b> <b>Calling tone</b> <b>Conditions</b>	
<b>Called station</b> <b>identification</b> <b>Conditions</b>	<p>ANS 2 100 Hz <math>\pm</math> 15 Hz sine (Recommendation ITU-T V.25 [6])</p> <p>Duration 2,6 s to 4 s</p> <p>(Recommendation ITU-T G.168 [3], clause 6.4.2.11 Test No. 10 - Facsimile test)</p> <p>The amplitude of the tone is <b>-12 dBm0</b></p>

<b>Test number:</b>	<b>2.1.2 MODEM</b>
<b>Transmission Type:</b>	Modem with ANS/-31 dBm0
<b>Measurement procedure</b>	<p>I)</p> <ul style="list-style-type: none"> <li>• Establishing a new call from A to B and reset De-jitter buffer 1 and De-jitter buffer 2</li> <li>• Apply signal C16 to Interface A and determine the delay <math>D_{JB1}</math></li> <li>• Apply signal C16 to Interface B and determine the delay <math>D_{JB2}</math></li> <li>• Establishing a new call from A to B and reset De-jitter buffer 1 and De-jitter buffer 2</li> <li>• Apply signal ANS to Interface B</li> <li>• Apply signal C16 to Interface A and determine the delay <math>D_{JB1}</math> after sending ANS (from B)</li> <li>• Apply signal C16 to Interface B and determine the delay <math>D_{JB2}</math> after sending ANS (from B)</li> </ul> <p>II)</p> <ul style="list-style-type: none"> <li>• Establishing a new call from B to A and reset De-jitter buffer 1 and De-jitter buffer 2</li> <li>• Apply signal C16 to Interface B and determine the delay <math>D_{JB2}</math></li> <li>• Apply signal C16 to Interface A and determine the delay <math>D_{JB1}</math></li> <li>• Establishing a new call from B to A and reset De-jitter buffer 1 and De-jitter buffer 2</li> <li>• Apply signal ANS to Interface A</li> <li>• Apply signal C16 to Interface B and determine the delay <math>D_{JB1}</math> after sending ANS (from A)</li> <li>• Apply signal C16 to Interface A and determine the delay <math>D_{JB2}</math> after sending ANS (from A)</li> </ul>
<b>Requirement</b>	<p>I)</p> <ul style="list-style-type: none"> <li>a) First call; <math>D_{JB1} = D_{JB2}</math> Delay for De-jitter buffer Adaptive</li> <li>b) Second call; <math>D_{JB1} = D_{JB2}</math> for Delay for De-jitter buffer Fixed</li> </ul> <p>II)</p> <ul style="list-style-type: none"> <li>a) First call; <math>D_{JB1} = D_{JB2}</math> Delay for De-jitter buffer Adaptive</li> <li>b) Second call; <math>D_{JB1} = D_{JB2}</math> for Delay for De-jitter buffer Fixed</li> </ul>
<b>Modem test sequences: Calling tone Conditions</b>	
<b>Called station identification Conditions</b>	<p>ANS 2 100 Hz <math>\pm</math> 15 Hz sine (Recommendation ITU-T V.25 [6])  Duration 2,6 s to 4 s  (Recommendation ITU-T G.168 [3], clause 6.4.2.11 Test No. 10 - Facsimile test)  The amplitude of the tone is <b>-31 dBm0</b></p>

<b>Test number:</b>	<b>2.2.1 MODEM</b>
<b>Transmission Type:</b>	Modem with early VBD detection with CT/-12 dBm0
<b>Measurement procedure</b>	<p>I)</p> <ul style="list-style-type: none"> <li>• Establishing a new call from A to B and reset De-jitter buffer 1 and De-jitter buffer 2</li> <li>• Apply signal C16 to Interface A and determine the delay <math>D_{JB1}</math></li> <li>• Apply signal C16 to Interface B and determine the delay <math>D_{JB2}</math></li> <li>• Establishing a new call from A to B and reset De-jitter buffer 1 and De-jitter buffer 2</li> <li>• Apply signal CT, 1 300 Hz signal (V.25) to Interface A</li> <li>• Apply signal C16 to Interface A and determine the delay <math>D_{JB1}</math> after CT, 1 300 Hz signal (V.25) to Interface A</li> <li>• Apply signal C16 to Interface B and determine the delay <math>D_{JB2}</math> after sending CT, 1 300 Hz signal (V.25) to Interface A</li> </ul> <p>II)</p> <ul style="list-style-type: none"> <li>• Establishing a new call from B to A and reset De-jitter buffer 1 and De-jitter buffer 2</li> <li>• Apply signal C16 to Interface B and determine the delay <math>D_{JB2}</math></li> <li>• Apply signal C16 to Interface A and determine the delay <math>D_{JB1}</math></li> <li>• Establishing a new call from B to A and reset De-jitter buffer 1 and De-jitter buffer 2</li> <li>• Apply signal CT, 1 300 Hz signal (V.25) to Interface B</li> <li>• Apply signal C16 to Interface B and determine the delay <math>D_{JB1}</math> after sending ANS (from A)</li> <li>• Apply signal C16 to Interface A and determine the delay <math>D_{JB2}</math> after sending ANS (from A)</li> </ul>
<b>Requirement</b>	<p>I)</p> <ul style="list-style-type: none"> <li>a) First call; <math>D_{JB1} = D_{JB2}</math> Delay for De-jitter buffer Adaptive</li> <li>b) Second call; <math>D_{JB1} = D_{JB2}</math> for Delay for De-jitter buffer Fixed</li> </ul> <p>II)</p> <ul style="list-style-type: none"> <li>a) First call; <math>D_{JB1} = D_{JB2}</math> Delay for De-jitter buffer Adaptive</li> <li>b) Second call; <math>D_{JB1} = D_{JB2}</math> De-jitter buffer Fixed</li> </ul>
<b>Modem test sequences:</b>	Signal 1 300 Hz
<b>Calling tone Conditions</b>	Duration On for 0,5 s to 0,7 s, Off for 1,5 s to 2 s
<b>Called station identification Conditions</b>	The amplitude of the tone is <b>-12 dBm0</b>

<b>Test number:</b>	<b>2.2.2 MODEM</b>
<b>Transmission Type:</b>	Modem with early VBD detection with CT/-31 dBm0
<b>Measurement procedure</b>	<p>I)</p> <ul style="list-style-type: none"> <li>• Establishing a new call from A to B and reset De-de-jitter buffer 1 and De-de-jitter buffer 2</li> <li>• Apply signal C16 to Interface A and determine the delay <math>D_{JB1}</math></li> <li>• Apply signal C16 to Interface B and determine the delay <math>D_{JB2}</math></li> <li>• Establishing a new call from A to B and reset De-de-jitter buffer 1 and De-de-jitter buffer 2</li> <li>• Apply signal CT, 1 300 Hz signal (V.25) to Interface A</li> <li>• Apply signal C16 to Interface A and determine the delay <math>D_{JB1}</math> after CT, 1 300 Hz signal (V.25) to Interface A</li> <li>• Apply signal C16 to Interface B and determine the delay <math>D_{JB2}</math> after sending CT, 1 300 Hz signal (V.25) to Interface A</li> </ul> <p>II)</p> <ul style="list-style-type: none"> <li>• Establishing a new call from B to A and reset De-de-jitter buffer 1 and De-de-jitter buffer 2</li> <li>• Apply signal C16 to Interface B and determine the delay <math>D_{JB2}</math></li> <li>• Apply signal C16 to Interface A and determine the delay <math>D_{JB1}</math></li> <li>• Establishing a new call from B to A and reset De-de-jitter buffer 1 and De-de-jitter buffer 2</li> <li>• Apply signal CT, 1 300 Hz signal (V.25) to Interface B</li> <li>• Apply signal C16 to Interface B and determine the delay <math>D_{JB1}</math> after sending ANS (from A)</li> <li>• Apply signal C16 to Interface A and determine the delay <math>D_{JB2}</math> after sending ANS (from A)</li> </ul>
<b>Requirement</b>	<p>I)</p> <ul style="list-style-type: none"> <li>a) First call; <math>D_{JB1} = D_{JB2}</math> Delay for De-de-jitter buffer Adaptive</li> <li>b) Second call; <math>D_{JB1} = D_{JB2}</math> for Delay for De-de-jitter buffer Fixed</li> </ul> <p>II)</p> <ul style="list-style-type: none"> <li>a) First call; <math>D_{JB1} = D_{JB2}</math> Delay for De-de-jitter buffer Adaptive</li> <li>b) Second call; <math>D_{JB1} = D_{JB2}</math> De-de-jitter buffer Fixed</li> </ul>
<b>Modem test sequences:</b>	Signal 1 300 Hz
<b>Calling tone Conditions</b>	Duration On for 0,5 s to 0,7 s, Off for 1,5 s to 2 s
<b>Called station identification Conditions</b>	The amplitude of the tone is <b>-31 dBm0</b>
<b>Called station identification Conditions</b>	

<b>Test number:</b>	<b>2.3.1 MODEM</b>
<b>Transmission Type:</b>	Modem with ANSam/-12 dBm0
<b>Measurement procedure</b>	<p>I)</p> <ul style="list-style-type: none"> <li>• Establishing a new call from A to B and reset De-jitter buffer 1 and De-jitter buffer 2</li> <li>• Apply signal C16 to Interface A and determine the delay <math>D_{JB1}</math></li> <li>• Apply signal C16 to Interface B and determine the delay <math>D_{JB2}</math></li> <li>• Establishing a new call from A to B and reset De-jitter buffer 1 and De-jitter buffer 2</li> <li>• Apply signal ANSam to Interface B</li> <li>• Apply signal C16 to Interface A and determine the delay <math>D_{JB1}</math> after sending ANSam (from B)</li> <li>• Apply signal C16 to Interface B and determine the delay <math>D_{JB2}</math> after sending ANSam (from B)</li> </ul> <p>II)</p> <ul style="list-style-type: none"> <li>• Establishing a new call from B to A and reset De-jitter buffer 1 and De-jitter buffer 2</li> <li>• Apply signal C16 to Interface B and determine the delay <math>D_{JB2}</math></li> <li>• Apply signal C16 to Interface A and determine the delay <math>D_{JB1}</math></li> <li>• Establishing a new call from B to A and reset De-jitter buffer 1 and De-jitter buffer 2</li> <li>• Apply signal ANSam to Interface A</li> <li>• Apply signal C16 to Interface B and determine the delay <math>D_{JB1}</math> after sending ANSam (from A)</li> <li>• Apply signal C16 to Interface A and determine the delay <math>D_{JB2}</math> after sending ANSam (from A)</li> </ul>
<b>Requirement</b>	<p>I)</p> <ul style="list-style-type: none"> <li>a) First call; <math>D_{JB1} = D_{JB2}</math> Delay for De-jitter buffer Adaptive</li> <li>b) Second call; <math>D_{JB1} = D_{JB2}</math> for Delay for De-jitter buffer Fixed</li> </ul> <p>II)</p> <ul style="list-style-type: none"> <li>a) First call; <math>D_{JB1} = D_{JB2}</math> Delay for De-jitter buffer Adaptive</li> <li>b) Second call; <math>D_{JB1} = D_{JB2}</math> for Delay for De-jitter buffer Fixed</li> </ul>
<b>Modem test sequences:</b>	
<b>Calling tone Conditions</b>	
<b>Called station identification Conditions</b>	<p>ANSam 2 100 Hz sine with a 20 % amplitude modulation by a 15 Hz sine (Recommendation ITU-T V.25 [6])</p> <p>The amplitude of the tone is <b>-12 dBm0</b></p>

<b>Test number:</b>	<b>2.3.2 MODEM</b>
<b>Transmission Type:</b>	Modem with ANSam/-31 dBm0
<b>Measurement procedure</b>	<p>I)</p> <ul style="list-style-type: none"> <li>• Establishing a new call from A to B and reset De-jitter buffer 1 and De-jitter buffer 2</li> <li>• Apply signal C16 to Interface A and determine the delay <math>D_{JB1}</math></li> <li>• Apply signal C16 to Interface B and determine the delay <math>D_{JB2}</math></li> <li>• Establishing a new call from A to B and reset De-jitter buffer 1 and De-jitter buffer 2</li> <li>• Apply signal ANSam to Interface B</li> <li>• Apply signal C16 to Interface A and determine the delay <math>D_{JB1}</math> after sending ANSam (from B)</li> <li>• Apply signal C16 to Interface B and determine the delay <math>D_{JB2}</math> after sending ANSam (from B)</li> </ul> <p>II)</p> <ul style="list-style-type: none"> <li>• Establishing a new call from B to A and reset De-jitter buffer 1 and De-jitter buffer 2</li> <li>• Apply signal C16 to Interface B and determine the delay <math>D_{JB2}</math></li> <li>• Apply signal C16 to Interface A and determine the delay <math>D_{JB1}</math></li> <li>• Establishing a new call from B to A and reset De-jitter buffer 1 and De-jitter buffer 2</li> <li>• Apply signal ANSam to Interface A</li> <li>• Apply signal C16 to Interface B and determine the delay <math>D_{JB1}</math> after sending ANSam (from A)</li> <li>• Apply signal C16 to Interface A and determine the delay <math>D_{JB2}</math> after sending ANSam (from A)</li> </ul>
<b>Requirement</b>	<p>I)</p> <p>a) First call; <math>D_{JB1} = D_{JB2}</math> Delay for De-jitter buffer Adaptive  b) Second call; <math>D_{JB1} = D_{JB2}</math> for Delay for De-jitter buffer Fixed</p> <p>II)</p> <p>a) First call; <math>D_{JB1} = D_{JB2}</math> Delay for De-jitter buffer Adaptive  b) Second call; <math>D_{JB1} = D_{JB2}</math> for Delay for De-jitter buffer Fixed</p>
<b>Modem test sequences:</b>	
<b>Calling tone Conditions</b>	
<b>Called station identification Conditions</b>	ANSam 2 100 Hz sine with a 20 % amplitude modulation by a 15 Hz sine Recommendation ITU-T V.25 [6] The amplitude of the tone is <b>-31 dBm0</b>

<b>Test number:</b>	<b>2.4.1 MODEM</b>
<b>Transmission Type:</b>	Modem with early VBD detection with CI Signal (V.8)/-12 dBm0
<b>Measurement procedure</b>	<p>I)</p> <ul style="list-style-type: none"> <li>• Establishing a new call from A to B and reset De-jitter buffer 1 and De-jitter buffer 2</li> <li>• Apply signal C16 to Interface A and determine the delay <math>D_{JB1}</math></li> <li>• Apply signal C16 to Interface B and determine the delay <math>D_{JB2}</math></li> <li>• Establishing a new call from A to B and reset De-jitter buffer 1 and De-jitter buffer 2</li> <li>• Apply signal CI Signal (V.8) to Interface A</li> <li>• Apply signal C16 to Interface A and determine the delay <math>D_{JB1}</math> after sending CI Signal (V.8) to Interface A</li> <li>• Apply signal C16 to Interface B and determine the delay <math>D_{JB2}</math> after sending CI Signal (V.8) to Interface A</li> </ul> <p>II)</p> <ul style="list-style-type: none"> <li>• Establishing a new call from B to A and reset De-jitter buffer 1 and De-jitter buffer 2</li> <li>• Apply signal C16 to Interface B and determine the delay <math>D_{JB2}</math></li> <li>• Apply signal C16 to Interface A and determine the delay <math>D_{JB1}</math></li> <li>• Establishing a new call from B to A and reset De-jitter buffer 1 and De-jitter buffer 2</li> <li>• Apply signal CI Signal (V.8) to Interface B</li> <li>• Apply signal C16 to Interface B and determine the delay <math>D_{JB1}</math> after sending CI Signal (V.8) to Interface B</li> <li>• Apply signal C16 to Interface A and determine the delay <math>D_{JB2}</math> after sending CI Signal (V.8) to Interface B</li> </ul>
<b>Requirement</b>	<p>I)</p> <p>a) First call; <math>D_{JB1} = D_{JB2}</math> Delay for De-jitter buffer Adaptive</p> <p>b) Second call; <math>D_{JB1} = D_{JB2}</math> for Delay De-jitter buffer Fixed</p> <p>II)</p> <p>a) First call; <math>D_{JB1} = D_{JB2}</math> Delay for De-jitter buffer Adaptive</p> <p>b) Second call; <math>D_{JB1} = D_{JB2}</math> for Delay for De-jitter buffer Fixed</p>
<b>Modem test sequences:</b>	CI Signal (V.8)
<b>Calling tone Conditions</b>	The amplitude of the tone is -12 dBm0
<b>Called station identification Conditions</b>	



<b>Test number:</b>	<b>2.4.2 MODEM</b>
<b>Transmission Type:</b>	Modem with early VBD detection with CI Signal (V.8)/-31 dBm0
<b>Measurement procedure</b>	<p>I)</p> <ul style="list-style-type: none"> <li>• Establishing a new call from A to B and reset De-jitter buffer 1 and De-jitter buffer 2</li> <li>• Apply signal C16 to Interface A and determine the delay <math>D_{JB1}</math></li> <li>• Apply signal C16 to Interface B and determine the delay <math>D_{JB2}</math></li> <li>• Establishing a new call from A to B and reset De-jitter buffer 1 and De-jitter buffer 2</li> <li>• Apply signal CI Signal (V.8) to Interface A</li> <li>• Apply signal C16 to Interface A and determine the delay <math>D_{JB1}</math> after sending CI Signal (V.8) to Interface A</li> <li>• Apply signal C16 to Interface B and determine the delay <math>D_{JB2}</math> after sending CI Signal (V.8) to Interface A</li> </ul> <p>II)</p> <ul style="list-style-type: none"> <li>• Establishing a new call from B to A and reset De-jitter buffer 1 and De-jitter buffer 2</li> <li>• Apply signal C16 to Interface B and determine the delay <math>D_{JB2}</math></li> <li>• Apply signal C16 to Interface A and determine the delay <math>D_{JB1}</math></li> <li>• Establishing a new call from B to A and reset De-jitter buffer 1 and De-jitter buffer 2</li> <li>• Apply signal CI Signal (V.8) to Interface B</li> <li>• Apply signal C16 to Interface B and determine the delay <math>D_{JB1}</math> after sending CI Signal (V.8) to Interface B</li> <li>• Apply signal C16 to Interface A and determine the delay <math>D_{JB2}</math> after sending CI Signal (V.8) to Interface B</li> </ul>
<b>Requirement</b>	<p>I)</p> <ul style="list-style-type: none"> <li>a) First call; <math>D_{JB1} = D_{JB2}</math> Delay for De-jitter buffer Adaptive</li> <li>b) Second call; <math>D_{JB1} = D_{JB2}</math> for Delay for De-jitter buffer Fixed</li> </ul> <p>II)</p> <ul style="list-style-type: none"> <li>a) First call; <math>D_{JB1} = D_{JB2}</math> Delay for De-jitter buffer Adaptive</li> <li>b) Second call; <math>D_{JB1} = D_{JB2}</math> for Delay for De-jitter buffer Fixed</li> </ul>
<b>Modem test sequences:</b>	CI Signal (V.8)
<b>Calling tone Conditions</b>	The amplitude of the tone is <b>-31 dBm0</b>
<b>Called station identification Conditions</b>	

<b>Test number:</b>	<b>2.5.1_MODEM</b>
<b>Transmission Type:</b>	Modem with /ANS/- 12 dBm0
<b>Measurement procedure</b>	<p>I)</p> <ul style="list-style-type: none"> <li>• Establishing a new call from A to B and reset De-jitter buffer 1 and De-jitter buffer 2</li> <li>• Apply signal C16 to Interface A and determine the delay <math>D_{JB1}</math></li> <li>• Apply signal C16 to Interface B and determine the delay <math>D_{JB2}</math></li> <li>• Establishing a new call from A to B and reset De-jitter buffer 1 and De-jitter buffer 2</li> <li>• Apply signal/ANS to Interface B</li> <li>• Apply signal C16 to Interface A and determine the delay <math>D_{JB1}</math> after sending/ANS (from B)</li> <li>• Apply signal C16 to Interface B and determine the delay <math>D_{JB2}</math> after sending/ANS (from B)</li> </ul> <p>II)</p> <ul style="list-style-type: none"> <li>• Establishing a new call from B to A and reset De-jitter buffer 1 and De-jitter buffer 2</li> <li>• Apply signal C16 to Interface B and determine the delay <math>D_{JB2}</math></li> <li>• Apply signal C16 to Interface A and determine the delay <math>D_{JB1}</math></li> <li>• Establishing a new call from B to A and reset De-jitter buffer 1 and De-jitter buffer 2</li> <li>• Apply signal/ANS to Interface A</li> <li>• Apply signal C16 to Interface B and determine the delay <math>D_{JB1}</math> after sending/ANS(from A)</li> <li>• Apply signal C16 to Interface A and determine the delay <math>D_{JB2}</math> after sending/ANS(from A)</li> </ul>
<b>Requirement</b>	<p>I)</p> <ul style="list-style-type: none"> <li>a) First call; <math>D_{JB1} = D_{JB2}</math> Delay for De-jitter buffer Adaptive</li> <li>b) Second call; <math>D_{JB1} = D_{JB2}</math> for Delay for De-jitter buffer Fixed</li> </ul> <p>II)</p> <ul style="list-style-type: none"> <li>a) First call; <math>D_{JB1} = D_{JB2}</math> Delay for De-jitter buffer Adaptive</li> <li>b) Second call; <math>D_{JB1} = D_{JB2}</math> for Delay for De-jitter buffer Fixed</li> </ul>
<b>Modem test sequences:</b>	
<b>Calling tone Conditions</b>	
<b>Called station identification Conditions</b>	/ANS 2 100 Hz sine with 180° phase shift every 450 ms (Recommendation ITU-T V.25 [6]) Duration 2,6 s to 4 s The amplitude of the tone is <b>-12 dBm0</b>

<b>Test number:</b>	<b>2.5.2 MODEM</b>
<b>Transmission Type:</b>	Modem with /ANS/-31 dBm0
<b>Measurement procedure</b>	<p>I)</p> <ul style="list-style-type: none"> <li>• Establishing a new call from A to B and reset De-jitter buffer 1 and De-jitter buffer 2</li> <li>• Apply signal C16 to Interface A and determine the delay <math>D_{JB1}</math></li> <li>• Apply signal C16 to Interface B and determine the delay <math>D_{JB2}</math></li> <li>• Establishing a new call from A to B and reset De-jitter buffer 1 and De-jitter buffer 2</li> <li>• Apply signal/ANS to Interface B</li> <li>• Apply signal C16 to Interface A and determine the delay <math>D_{JB1}</math> after sending/ANS (from B)</li> <li>• Apply signal C16 to Interface B and determine the delay <math>D_{JB2}</math> after sending/ANS (from B)</li> </ul> <p>II)</p> <ul style="list-style-type: none"> <li>• Establishing a new call from B to A and reset De-jitter buffer 1 and De-jitter buffer 2</li> <li>• Apply signal C16 to Interface B and determine the delay <math>D_{JB2}</math></li> <li>• Apply signal C16 to Interface A and determine the delay <math>D_{JB1}</math></li> <li>• Establishing a new call from B to A and reset De-jitter buffer 1 and De-jitter buffer 2</li> <li>• Apply signal/ANS to Interface A</li> <li>• Apply signal C16 to Interface B and determine the delay <math>D_{JB1}</math> after sending/ANS(from A)</li> <li>• Apply signal C16 to Interface A and determine the delay <math>D_{JB2}</math> after sending/ANS(from A)</li> </ul>
<b>Requirement</b>	<p>I)</p> <ul style="list-style-type: none"> <li>a) First call; <math>D_{JB1} = D_{JB2}</math> Delay for De-jitter buffer Adaptive</li> <li>b) Second call; <math>D_{JB1} = D_{JB2}</math> De-jitter buffer Fixed</li> </ul> <p>II)</p> <ul style="list-style-type: none"> <li>a) First call; <math>D_{JB1} = D_{JB2}</math> Delay for De-jitter buffer Adaptive</li> <li>b) Second call; <math>D_{JB1} = D_{JB2}</math> for Delay De-jitter buffer Fixed</li> </ul>
<b>Modem test sequences: Calling tone Conditions</b>	
<b>Called station identification Conditions</b>	/ANS 2 100 Hz sine with 180° phase shift every 450 ms (Recommendation ITU-T V.25 [6]) Duration 2,6 s to 4 s The amplitude of the tone is <b>-31 dBm0</b>

<b>Test number:</b>	<b>2.6.1_MODEM</b>
<b>Transmission Type:</b>	Modem with /ANSam/- 12 dBm0
<b>Measurement procedure</b>	<p>I)</p> <ul style="list-style-type: none"> <li>• Establishing a new call from A to B and reset De-jitter buffer 1 and De-jitter buffer 2</li> <li>• Apply signal C16 to Interface A and determine the delay <math>D_{JB1}</math></li> <li>• Apply signal C16 to Interface B and determine the delay <math>D_{JB2}</math></li> <li>• Establishing a new call from A to B and reset De-jitter buffer 1 and De-jitter buffer 2</li> <li>• Apply signal/ANSam to Interface B</li> <li>• Apply signal C16 to Interface A and determine the delay <math>D_{JB1}</math> after sending/ANSam (from B)</li> <li>• Apply signal C16 to Interface B and determine the delay <math>D_{JB2}</math> after sending/ANSam (from B)</li> </ul> <p>II)</p> <ul style="list-style-type: none"> <li>• Establishing a new call from B to A and reset De-jitter buffer 1 and De-jitter buffer 2</li> <li>• Apply signal C16 to Interface B and determine the delay <math>D_{JB2}</math></li> <li>• Apply signal C16 to Interface A and determine the delay <math>D_{JB1}</math></li> <li>• Establishing a new call from B to A and reset De-jitter buffer 1 and De-jitter buffer 2</li> <li>• Apply signal/ANSam to Interface A</li> <li>• Apply signal C16 to Interface B and determine the delay <math>D_{JB1}</math> after sending/ANSam(from A)</li> <li>• Apply signal C16 to Interface A and determine the delay <math>D_{JB2}</math> after sending/ANSam(from A)</li> </ul>
<b>Requirement</b>	<p>I)</p> <ul style="list-style-type: none"> <li>a) First call; <math>D_{JB1} = D_{JB2}</math> Delay for De-jitter buffer Adaptive</li> <li>b) Second call; <math>D_{JB1} = D_{JB2}</math> for Delay for De-jitter buffer Fixed</li> </ul> <p>II)</p> <ul style="list-style-type: none"> <li>a) First call; <math>D_{JB1} = D_{JB2}</math> Delay for De-jitter buffer Adaptive</li> <li>b) Second call; <math>D_{JB1} = D_{JB2}</math> for Delay for De-jitter buffer Fixed</li> </ul>
<b>Modem test sequences:</b>	
<b>Calling tone Conditions</b>	
<b>Called station identification Conditions</b>	/ANSam 2 100 Hz sine with a 20 % amplitude modulation by a 15 Hz sine and 180° phase shift every 450 ms (Recommendation ITU-T V.25 [6]) The amplitude of the tone is <b>-12 dBm0</b>

<b>Test number:</b>	<b>2.6.2 MODEM</b>
<b>Transmission Type:</b>	Modem with /ANSam/- 31 dBm0
<b>Measurement procedure</b>	<p>I)</p> <ul style="list-style-type: none"> <li>• Establishing a new call from A to B and reset De-jitter buffer 1 and De-jitter buffer 2</li> <li>• Apply signal C16 to Interface A and determine the delay <math>D_{JB1}</math></li> <li>• Apply signal C16 to Interface B and determine the delay <math>D_{JB2}</math></li> <li>• Establishing a new call from A to B and reset De-jitter buffer 1 and De-jitter buffer 2</li> <li>• Apply signal/ANSam to Interface B</li> <li>• Apply signal C16 to Interface A and determine the delay <math>D_{JB1}</math> after sending/ANSam (from B)</li> <li>• Apply signal C16 to Interface B and determine the delay <math>D_{JB2}</math> after sending/ANSam (from B)</li> </ul> <p>II)</p> <ul style="list-style-type: none"> <li>• Establishing a new call from B to A and reset De-jitter buffer 1 and De-jitter buffer 2</li> <li>• Apply signal C16 to Interface B and determine the delay <math>D_{JB2}</math></li> <li>• Apply signal C16 to Interface A and determine the delay <math>D_{JB1}</math></li> <li>• Establishing a new call from B to A and reset De-jitter buffer 1 and De-jitter buffer 2</li> <li>• Apply signal/ANSam to Interface A</li> <li>• Apply signal C16 to Interface B and determine the delay <math>D_{JB1}</math> after sending/ANSam(from A)</li> <li>• Apply signal C16 to Interface A and determine the delay <math>D_{JB2}</math> after sending/ANSam(from A)</li> </ul>
<b>Requirement</b>	<p>I)</p> <ul style="list-style-type: none"> <li>a) First call; <math>D_{JB1} = D_{JB2}</math> Delay for De-jitter buffer Adaptive</li> <li>b) Second call; <math>D_{JB1} = D_{JB2}</math> for Delay for De-jitter buffer Fixed</li> </ul> <p>II)</p> <ul style="list-style-type: none"> <li>a) First call; <math>D_{JB1} = D_{JB2}</math> Delay for De-jitter buffer Adaptive</li> <li>b) Second call; <math>D_{JB1} = D_{JB2}</math> for Delay for De-jitter buffer Fixed</li> </ul>
<b>Modem test sequences:</b>	
<b>Calling tone Conditions</b>	
<b>Called station identification Conditions</b>	/ANSam 2 100 Hz sine with a 20 % amplitude modulation by a 15 Hz sine and 180° phase shift every 450 ms [5]) The amplitude of the tone is <b>-31 dBm0</b>

## Annex B (normative): Echo canceller Tests

### B.1 Introduction

#### B.1.1 Signals used

The following tests contains Echo canceller Tests based on disabling characteristics described in Recommendations ITU-T G.168 [3] and G.164 [i.1].

C16	Signal of Test 2A (Recommendation ITU-T G.168 [3]), average level -16 dBm0 Gaussian white noise signal which is used to identify the echo-path impulse response
D16	Signal consisting of DTMF tones <b>0123456789#ABCD*</b> with signal-to-pause relationship corresponding to that of C16, average level -16 dBm0
ANS	2 100 Hz sine (Recommendation ITU-T V.25 [6]) The duration of the tone is set to $T1 = 1,35$ s. The amplitude of the tone is -12 dBm0
ANSam	2 100 Hz sine with a 20 % amplitude modulation by a 15 Hz sine (Recommendation ITU-T V.25 [6])
/ANS	2 100 Hz sine with 180° phase shift every 450 ms (Recommendation ITU-T V.25 [6])
/ANSam	2 100 Hz sine with a 20 % amplitude modulation by a 15 Hz sine and 180° phase shift every 450 ms (Recommendation ITU-T V.25 [6])
FAX	Sequence No. 1 (Recommendation ITU-T G.168 [3], clause 6.4.2.11)

#### B.1.2 Preparatory measurements

The  $JRL_{SND}$  and  $JLR_{RCV}$  are to be determined according to figure B.1.

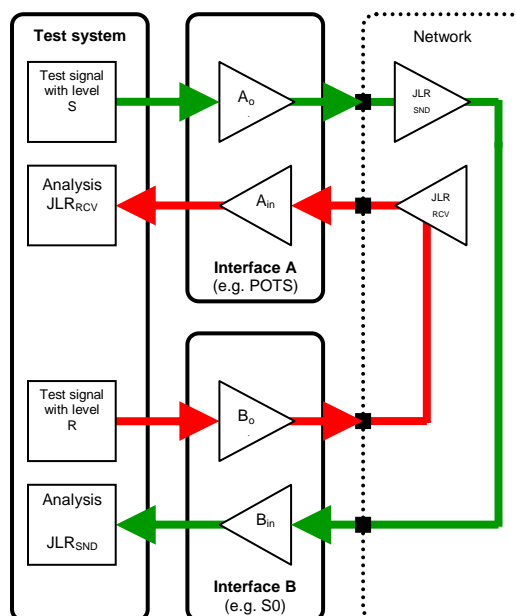

**Figure B.1: Echo simulation for determination of  $JRL_{SND}$  and  $JLR_{RCV}$**

As a test signal, the artificial voice should be used.

The possible attenuations/amplifications  $A_{in}$ ,  $A_{out}$ ,  $B_{in}$  and  $B_{out}$  are to be determined and used for compensation in the later measurements.

## B.2 Tests with echo simulation at Interface B

### B.2.1 Introduction

The measurement setup is shown in figure B.2.

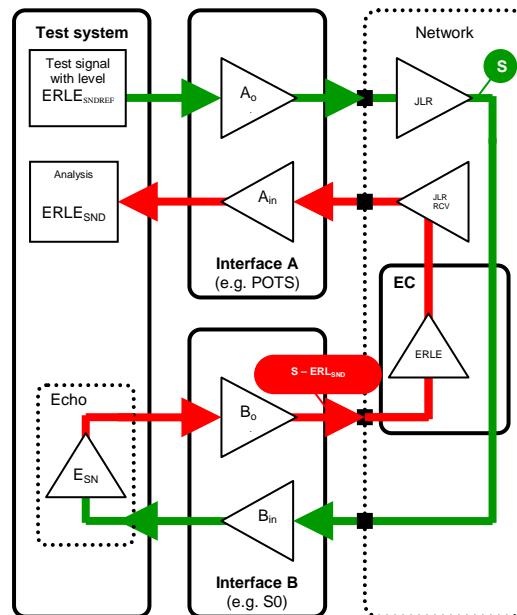

**Figure B.2: Measurement setup for echo simulation**

The levels marked as S and  $S - ERL_{SND}$  shall match at the respective points of the network.

$ERL_{SND}$  is to be set to 8 dB. Because network echo cancellers are tested in G.168 with ERL of 6 dB, even a small maladjustment of the levels in the complete system can lead into the situation that the EC does not consider the echo as but as near end speech. Therefore a safety margin of 2 dB is built in.

$ERL_{SNDREF}$  = Transmitted signal at interface A

$ERL_{SND}$  = Received signal measured at interface A

$A_o$ ,  $A_{in}$  = Input and output attenuation Interface A (shall be determined, see figure B.1)

$B_o$ ,  $B_{in}$  = Input and output attenuations at interface B (shall be determined, see figure B.1)

$JLR_{snd}$ ,  $JLR_{rcv}$  = Network Transmit and receive attenuations (shall be determined, see figure B.1)

$E_{snd}$  = Echo path loss in the test system

ERLE = echo return loss enhancement (only unknown)

$ERL_{SND} = ERL_{SNDREF} - A_o - JLR_{snd} - B_{in} - E_{snd} - B_o - ERLE - JLR_{rcv} - A_{in}$

$ERLE = ERL_{SNDREF} - ERL_{SND} - A_o - JLR_{snd} - B_{in} - E_{snd} - B_o - JLR_{rcv} - A_{in}$

$B_{in} + E_{snd} + B_o = 8 \text{ dB} \Rightarrow ERLE = ERL_{SNDREF} - ERL_{SND} - A_o - JLR_{snd} - 8 \text{ dB} - JLR_{rcv} - A_{in}$

If ECon:  $ERLE > 25 \text{ dB}$

If ECoff: ERLE > 1 dB

## B.2.2 Tests with test signals based on Composite Source Signal (CSS)

### B.2.2.1 Answer tones + C16

Test number	1.1.1.1; ANS (from B) + C16
Measurement procedure	<ul style="list-style-type: none"> <li>Establishing a new call from A to B and reset EC</li> <li>Apply signal C16 to Interface A and determine <math>ERLE_{SNDREF}</math></li> <li>Establishing a new call from A to B and reset EC</li> <li>Apply signal ANS to Interface B</li> <li>Apply signal C16 to Interface A and determine <math>ERLE_{SND}</math> after sending ANS (from B)</li> </ul>
Requirement	<p>Establishing a new call from A to B the EC is active (EC on). After the receiving ANS from B, the EC will not change the state (EC on).</p> <p>⇒ <math>ERLE = ERLE_{sndref} - ERLE_{snd} - A_o - JLR_{snd} - Bin - Esnd - B_o - JLR_{rcv} - A_{in}</math></p> <p>1) Before receiving ANS; ECon =&gt; ERLE &gt; 25 dB 2) After the receiving ANS; ECon =&gt; ERLE &gt; 25 dB</p>
Note:	

Test number	1.1.1.2; ANSam (from B) + C16
Measurement procedure	<ul style="list-style-type: none"> <li>Establishing a new call from A to B and reset EC</li> <li>Apply signal C16 to Interface A and determine <math>ERLE_{SNDREF}</math></li> <li>Establishing a new call from A to B and reset EC</li> <li>Apply signal ANSam to Interface B</li> <li>Apply signal C16 to Interface A and determine <math>ERLE_{SND}</math> after sending for ANSam (from B)</li> </ul>
Requirement	<p>Establishing a new call from A to B the EC is active (EC on). After the receiving ANSam from B, the EC will not change the state (EC on).</p> <p>⇒ <math>ERLE = ERLE_{sndref} - ERLE_{snd} - A_o - JLR_{snd} - Bin - Esnd - B_o - JLR_{rcv} - A_{in}</math></p> <p>1) Before receiving ANSam; ECon =&gt; ERLE &gt; 25 dB 2) After the receiving ANSam; ECon =&gt; ERLE &gt; 25 dB</p>
Note:	

Test number	1.1.1.3; /ANS (from B) + C16
Measurement procedure	<ul style="list-style-type: none"> <li>Establishing a new call from A to B and reset EC</li> <li>Apply signal C16 to Interface A and determine <math>ERLE_{SNDREF}</math> to ensure that ERLSND is to be set to 8 dB</li> <li>Establishing a new call from A to B and reset EC</li> <li>Apply signal/ANS to Interface B</li> <li>Apply signal C16 to Interface A and determine <math>ERLE_{SND}</math> after sending/ANS (from B)</li> </ul>
Requirement	<p>Establishing a new call from A to B the EC is active (EC on). After the receiving/ANS from B, the EC will change the state (EC off).</p> <p>⇒ <math>ERLE = ERLE_{sndref} - ERLE_{snd} - A_o - JLR_{snd} - Bin - Esnd - B_o - JLR_{rcv} - A_{in}</math></p> <p>1) Before receiving/ANS; ECon =&gt; ERLE &gt; 25 dB 2) After the receiving/ANS; ECoff =&gt; ERLE &gt; 1 dB</p>
Note:	



<b>Test number</b>	<b>1.1.1.4; /ANSam (from B) + C16</b>
<b>Measurement procedure</b>	<ul style="list-style-type: none"> <li>• Establishing a new call from A to B and reset EC</li> <li>• Apply signal C16 to Interface A and determine <math>ERLE_{SNDREF}</math></li> <li>• Establishing a new call from A to B and reset EC</li> <li>• Apply signal/ANSam to Interface B</li> <li>• Apply signal C16 to Interface A and determine <math>ERLE_{SND}</math> after sending/ANSam (from B)</li> </ul>
<b>Requirement</b>	<p>Establishing a new call from A to B the EC is active (EC on).          After the receiving/ANSam from B, the EC will change the state (EC off).  <math>\Rightarrow ERLE = ERLE_{sndref} - ERLE_{snd} - Ao - JLR_{snd} - Bin - Esnd - Bo - JLR_{rcv} - Ain</math></p> <p>1) Before receiving/ANSam; <math>ECon \Rightarrow ERLE &gt; 25</math> dB          2) After the receiving/ANSam; <math>ECoft \Rightarrow ERLE &gt; 1</math> dB</p>
<b>Note:</b>	

### B.2.2.2 Answer tones + first fax frame + C16

<b>Test number</b>	<b>1.1.2.1; ANS (from B) + FAX (from B) + C16</b>
<b>Measurement procedure</b>	<ul style="list-style-type: none"> <li>• Establishing a new call from A to B and reset EC</li> <li>• Apply signal C16 to Interface A and determine <math>ERLE_{SNDREF}</math></li> <li>• Establishing a new call from A to B and reset EC</li> <li>• Apply signal ANS to Interface B</li> <li>• Apply signal FAX to Interface B</li> <li>• Apply signal C16 to Interface A and determine <math>ERLE_{SND}</math> after sending ANS (from B)</li> </ul>
<b>Requirement</b>	<p>Establishing a new call from A to B the EC is active (EC on).          After the receiving ANS from B, the EC will not change the state (EC on)  <math>\Rightarrow ERLE = ERLE_{sndref} - ERLE_{snd} - Ao - JLR_{snd} - Bin - Esnd - Bo - JLR_{rcv} - Ain</math></p> <p>1) Before receiving ANS; <math>ECon \Rightarrow ERLE &gt; 25</math> dB          2) After the receiving ANS; <math>ECon \Rightarrow ERLE &gt; 25</math> dB</p>
<b>Note:</b>	

<b>Test number</b>	<b>1.1.2.2; ANSAm (from B) + FAX (from B) + C16</b>
<b>Measurement procedure</b>	<ul style="list-style-type: none"> <li>• Establishing a new call from A to B and reset EC</li> <li>• Apply signal C16 to Interface A and determine <math>ERLE_{SNDREF}</math></li> <li>• Establishing a new call from A to B and reset EC</li> <li>• Apply signal ANSAm to Interface B</li> <li>• Apply signal FAX to Interface B</li> <li>• Apply signal C16 to Interface A and determine <math>ERLE_{SND}</math> after sending for ANSAm (from B)</li> </ul>
<b>Requirement</b>	<p>Establishing a new call from A to B the EC is active (EC on).          After the receiving ANSAm from B, the EC will not change the state (EC on)  <math>\Rightarrow ERLE = ERLE_{sndref} - ERLE_{snd} - Ao - JLR_{snd} - Bin - Esnd - Bo - JLR_{rcv} - Ain</math></p> <p>1) Before receiving ANSAm; <math>ECon \Rightarrow ERLE &gt; 25</math> dB          2) After the receiving ANSAm; <math>ECon \Rightarrow ERLE &gt; 25</math> dB</p>
<b>Note:</b>	

<b>Test number</b>	<b>1.1.2.3; /ANS (from B) + FAX (from B) + C16</b>
<b>Measurement procedure</b>	<ul style="list-style-type: none"> <li>• Establishing a new call from A to B and reset EC</li> <li>• Apply signal C16 to Interface A and determine <math>ERLE_{SNDREF}</math></li> <li>• Establishing a new call from A to B and reset EC</li> <li>• Apply signal/ANS to Interface B</li> <li>• Apply signal FAX to Interface B</li> <li>• Apply signal C16 to Interface A and determine <math>ERLE_{SND}</math> after sending/ANS (from B)</li> </ul>
<b>Requirement</b>	<p>Establishing a new call from A to B the EC is active (EC on). After the receiving/ANS from B, the EC will change the state (EC off).</p> <p>⇒ <math>ERLE = ERLE_{sndref} - ERLE_{snd} - Ao - JLR_{snd} - Bin - Esnd - Bo - JLR_{rcv} - Ain</math></p> <p>1) Before receiving/ANS; <math>E_{Con} \Rightarrow ERLE &gt; 25</math> dB  2) After the receiving/ANS; <math>E_{Coff} \Rightarrow ERLE &gt; 1</math> dB</p>
<b>Note:</b>	

<b>Test number</b>	<b>1.1.2.4 /ANSam (from B) + FAX (from B) + C16</b>
<b>Measurement procedure</b>	<ul style="list-style-type: none"> <li>• Establishing a new call from A to B and reset EC</li> <li>• Apply signal C16 to Interface A and determine <math>ERLE_{SNDREF}</math></li> <li>• Establishing a new call from A to B and reset EC</li> <li>• Apply signal/ANSam to Interface B</li> <li>• Apply signal FAX to Interface B</li> <li>• Apply signal C16 to Interface A and determine <math>ERLE_{SND}</math> after sending/ANSam (from B)</li> </ul>
<b>Requirement</b>	<p>Establishing a new call from A to B the EC is active (EC on). After the receiving/ANSam from B, the EC will change the state (EC off).</p> <p>⇒ <math>ERLE = ERLE_{sndref} - ERLE_{snd} - Ao - JLR_{snd} - Bin - Esnd - Bo - JLR_{rcv} - Ain</math></p> <p>1) Before receiving/ANSam; <math>E_{Con} \Rightarrow ERLE &gt; 25</math> dB  2) After the receiving/ANSam; <math>E_{Coff} \Rightarrow ERLE &gt; 1</math> dB</p>
<b>Note:</b>	

### B.2.2.3 Tests with test signals based on the Use of the CI call signal and exchange of CM/JM menu signals + C16

<b>Test number</b>	<b>1.1.3.1 /ANSam + 4 x JM/6 x CM + CJ</b>
<b>Measurement procedure</b>	<ul style="list-style-type: none"> <li>• Establishing a new call from A to B and reset EC</li> <li>• Apply signal C16 to Interface A and determine <math>ERLE_{RCVREF}</math></li> <li>• Establishing a new call from A to B and reset EC</li> <li>• Apply signal/ANSam + 4 x JM to Interface B, and time-synchronously</li> <li>• Apply signal 6 x CM + CJ to Interface A</li> <li>• Apply signal C16 to Interface A and determine <math>ERLE_{RCV}</math> after sending/ANSam + 4 x JM (from B)</li> </ul>
<b>Requirement</b>	<p>Establishing a new call from A to B the EC is active (EC on). After the receiving/ANSam from B, the EC will change the state (EC off).</p> <p>⇒ <math>ERLE = ERLE_{rcvref} - ERLE_{rcv} - Bo - JLR_{rcv} - Ain - Ercv - Ao - JLR_{snd} - Bin</math></p> <p>1) Before receiving/ANSam + 4 x JM; <math>E_{Con} \Rightarrow ERLE &gt; 25</math> dB  2) After the receiving/ANSam; <math>E_{Coff} \Rightarrow ERLE &gt; 1</math> dB</p>
<b>Note:</b>	See figure 3.

## B.2.2.4 Tests with test signals based on DTMF

### B.2.2.4.1 Answer tones + D16

<b>Test number</b>	<b>1.1.4.1; ANS (from B) + D16</b>
<b>Measurement procedure</b>	<ul style="list-style-type: none"> <li>Establishing a new call from A to B and reset EC</li> <li>Apply signal D16 to Interface A and determine ERLESNDREF</li> <li>Establishing a new call from A to B and reset EC</li> <li>Apply signal ANS to Interface B</li> <li>Apply signal D16 to Interface A and determine ERLESND after sending ANS (from B)</li> </ul>
<b>Requirement</b>	<p>Establishing a new call from A to B the EC is active (EC on).            After the receiving ANS from B, the EC will not change the state (EC on)</p> <p>⇒ <math>ERLE = ERLESndref - ERLESnd - Ao - JLRsnd - Bin - Esnd - Bo - JLRrcv - Ain</math></p> <p>1) Before receiving ANS; ECon =&gt; <math>ERLE &gt; 25</math> dB            2) After the receiving ANS; ECon =&gt; <math>ERLE &gt; 25</math> dB</p>
<b>Note:</b>	

<b>Test number</b>	<b>1.1.4.2; ANSam (from B) + D16</b>
<b>Measurement procedure</b>	<ul style="list-style-type: none"> <li>Establishing a new call from A to B and reset EC</li> <li>Apply signal D16 to Interface A and determine ERLESNDREF</li> <li>Establishing a new call from A to B and reset EC</li> <li>Apply signal ANSam to Interface B</li> <li>Apply signal D16 to Interface A and determine <math>ERLE_{SND}</math> after sending for ANSam (from B)</li> </ul>
<b>Requirement</b>	<p>Establishing a new call from A to B the EC is active (EC on).            After the receiving ANS from B, the EC will not change the state (EC on)</p> <p>⇒ <math>ERLE = ERLESndref - ERLESnd - Ao - JLRsnd - Bin - Esnd - Bo - JLRrcv - Ain</math></p> <p>1) Before receiving ANSam; ECon =&gt; <math>ERLE &gt; 25</math> dB            2) After the receiving ANSam; ECon =&gt; <math>ERLE &gt; 25</math> dB</p>
<b>Note:</b>	$ERL_{SND}$ is to be set to 8 dB; $ERLE > 25$ dB

<b>Test number</b>	<b>1.1.4.3; /ANS (from B) + D16</b>
<b>Measurement procedure</b>	<ul style="list-style-type: none"> <li>Establishing a new call from A to B and reset EC</li> <li>Apply signal D16 to Interface A and determine ERLESNDREF to ensure that <math>ERL_{SND}</math> is to be set to 8 dB</li> <li>Establishing a new call from A to B and reset EC</li> <li>Apply signal/ANS to Interface B</li> <li>Apply signal D16 to Interface A and determine ERLESND after sending/ANS (from B)</li> </ul>
<b>Requirement</b>	<p>Establishing a new call from A to B the EC is active (EC on).            After the receiving/ANS from B, the EC will change the state (EC off).</p> <p>⇒ <math>ERLE = ERLESndref - ERLESnd - Ao - JLRsnd - Bin - Esnd - Bo - JLRrcv - Ain</math></p> <p>1) Before receiving/ANS; ECon =&gt; <math>ERLE &gt; 25</math> dB            2) After the receiving/ANS; ECoff =&gt; <math>ERLE &gt; 1</math> dB</p>
<b>Note:</b>	

<b>Test number</b>	<b>1.1.4.4; /ANSam (from B) + D16</b>
<b>Measurement procedure</b>	<ul style="list-style-type: none"> <li>• Establishing a new call from A to B and reset EC</li> <li>• Apply signal D16 to Interface A and determine <math>ERLE_{SNDREF}</math></li> <li>• Establishing a new call from A to B and reset EC</li> <li>• Apply signal/ANSam to Interface B</li> <li>• Apply signal D16 to Interface A and determine <math>ERLE_{SND}</math> after sending/ANSam (from B)</li> </ul>
<b>Requirement</b>	<p>Establishing a new call from A to B the EC is active (EC on).          After the receiving/ANSam from B, the EC will change the state (EC off).  <math>\Rightarrow ERLE = ERLE_{sndref} - ERLE_{snd} - Ao - JLR_{snd} - Bin - Esnd - Bo - JLR_{rcv} - Ain</math></p> <p>1) Before receiving/ANSam; <math>ECon \Rightarrow ERLE &gt; 25</math> dB          2) After the receiving/ANSam; <math>ECoff \Rightarrow ERLE &gt; 1</math> dB</p>
<b>Note:</b>	

### B.2.2.5 Tests with test signals based on the Use of the CI call signal and exchange of CM/JM menu signals + D16

<b>Test number</b>	<b>1.1.5.1; /ANSam + 4 x JM/6 x CM + CJ</b>
<b>Measurement procedure</b>	<ul style="list-style-type: none"> <li>• Establishing a new call from A to B and reset EC</li> <li>• Apply signal D16 to Interface A and determine <math>ERLE_{RCVREF}</math></li> <li>• Establishing a new call from A to B and reset EC</li> <li>• Apply signal/ANSam + 4 x JM to Interface B, and time-synchronously apply signal 6 x CM + CJ to Interface A</li> <li>• Apply signal D16 to Interface A and determine <math>ERLE_{RCV}</math> after sending/ANSam + 4 x JM (from B)</li> </ul>
<b>Requirement</b>	<p>Establishing a new call from A to B the EC is active (EC on).          After the receiving/ANSam from B, the EC will change the state (EC off).  <math>\Rightarrow ERLE = ERLE_{rcvref} - ERLE_{rcv} - Bo - JLR_{rcv} - Ain - Ercv - Ao - JLR_{snd} - Bin</math></p> <p>1) Before receiving/ANSam+ 4 x JM; <math>ECon \Rightarrow ERLE &gt; 25</math> dB          2) After the receiving/ANSam; <math>ECoff \Rightarrow ERLE &gt; 1</math> dB</p>
<b>Note:</b> See figure 3.	

## B.3 Tests with echo simulation at Interface A

### B.3.1 Introduction

The measurement setup is shown in figure B.3.

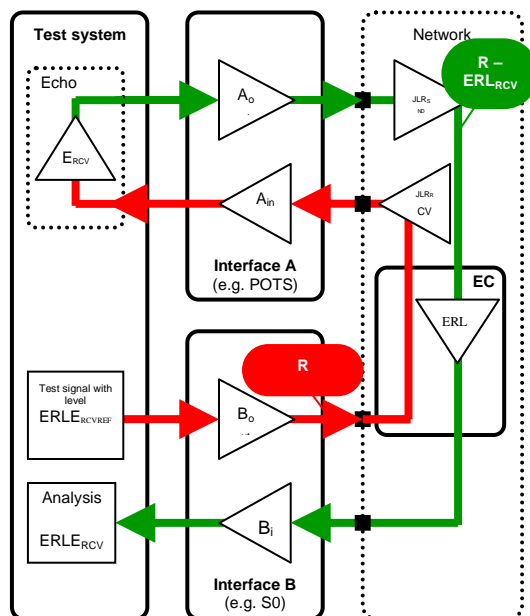

**Figure B.3: measurement setup for echo simulation**

The levels marked as R and R - ERLE<sub>RCV</sub> shall match at the respective points of the network.

ERLE<sub>RCV</sub> is to be set to 8 dB. Because network echo cancellers are tested in G.168 with ERL of 6 dB, even a small maladjustment of the levels in the complete system can lead into the situation that the EC does not consider the echo as echo but as near end speech. Therefore a safety margin of 2 dB is built in.

ERLE<sub>rcvref</sub> = Transmitted signal at interface B

ERLE<sub>rcv</sub> = Received signal measured at interface B

A<sub>o</sub>, A<sub>in</sub> = Input and output attenuation Interface A (shall be determined, see figure B.1)

B<sub>o</sub>, B<sub>in</sub> = Input and output attenuations at interface B (shall be determined, see figure B.1)

JLR<sub>snd</sub>, JLR<sub>rcv</sub> = Network Transmit and receive attenuations (shall be determined, see figure B.1)

E<sub>snd</sub> = Echo path loss in the test system

ERLE = echo return loss enhancement (only unknown)

ERLE<sub>rcv</sub> = ERLE<sub>rcvref</sub> - B<sub>o</sub> - JLR<sub>rcv</sub> - A<sub>in</sub> - E<sub>rcv</sub> - A<sub>o</sub> - ERLE - JLR<sub>snd</sub> - B<sub>in</sub>

ERLE = ERLE<sub>rcvref</sub> - ERLE<sub>rcv</sub> - B<sub>o</sub> - JLR<sub>rcv</sub> - A<sub>in</sub> - E<sub>rcv</sub> - A<sub>o</sub> - JLR<sub>snd</sub> - B<sub>in</sub>

A<sub>in</sub> + E<sub>rcv</sub> + A<sub>o</sub> = 8 dB => ERLE = ERLE<sub>rcvref</sub> - ERLE<sub>rcv</sub> - B<sub>o</sub> - JLR<sub>rcv</sub> - 8 dB - JLR<sub>snd</sub> - B<sub>in</sub>

If ECon: ERLE > 25 dB

If ECoff: ERLE > 1 dB

## B.3.2 Tests with test signals based on CSS

### B.3.2.1 Answer tones + C16

<b>Test number</b>	<b>2.1.1.1; ANS (from A) + C16</b>
<b>Measurement procedure</b>	<ul style="list-style-type: none"> <li>Establishing a new call from B to A and reset EC</li> <li>Apply signal C16 to Interface B and determine <math>ERLE_{RCVREF}</math></li> <li>Establishing a new call from B to A and reset EC</li> <li>Apply signal ANS to Interface A</li> <li>Apply signal C16 to Interface B and determine <math>ERLE_{RCV}</math> after sending ANS (from A)</li> </ul>
<b>Requirement</b>	<p>Establishing a new call from B to A the EC is active (EC on).            After the receiving ANS from A, the EC will not change the state (EC on).  <math>\Rightarrow ERLE = ERLE_{rcvref} - ERLE_{rcv} - Bo - JLR_{rcv} - Ain - Ercv - Ao - JLR_{snd} - Bin</math></p> <p>1) Before receiving ANS; ECon <math>\Rightarrow ERLE &gt; 25</math> dB            2) After the receiving ANS; ECon <math>\Rightarrow ERLE &gt; 25</math> dB</p>
<b>Note:</b>	

<b>Test number</b>	<b>2.1.1.2; ANSam (from A) + C16</b>
<b>Measurement procedure</b>	<ul style="list-style-type: none"> <li>Establishing a new call from B to A and reset EC</li> <li>Apply signal C16 to Interface B and determine <math>ERLE_{RCVREF}</math></li> <li>Establishing a new call from B to A and reset EC Apply signal ANSam to Interface A</li> <li>Apply signal C16 to Interface B and determine <math>ERLE_{RCV}</math> after sending ANSam (from A)</li> </ul>
<b>Requirement</b>	<p>Establishing a new call from B to A the EC is active (EC on).            After the receiving ANSam from A, the EC will not change the state (EC on).  <math>\Rightarrow ERLE = ERLE_{rcvref} - ERLE_{rcv} - Bo - JLR_{rcv} - Ain - Ercv - Ao - JLR_{snd} - Bin</math></p> <p>1) Before receiving ANSam; ECon <math>\Rightarrow ERLE &gt; 25</math> dB            2) After the receiving ANSam; ECon <math>\Rightarrow ERLE &gt; 25</math> dB</p>
<b>Note:</b>	

<b>Test number</b>	<b>2.1.1.3; /ANS (from A) + C16</b>
<b>Measurement procedure</b>	<ul style="list-style-type: none"> <li>Establishing a new call from B to A and reset EC</li> <li>Apply signal C16 to Interface B and determine <math>ERLE_{RCVREF}</math></li> <li>Apply signal/ANS to Interface A</li> <li>Establishing a new call from B to A and reset EC</li> <li>Apply signal C16 to Interface B and determine <math>ERLE_{RCV}</math> after sending/ANS (from A)</li> </ul>
<b>Requirement</b>	<p>Establishing a new call from B to A the EC is active (EC on).            After the receiving/ANS from A, the EC will change the state (EC off).  <math>\Rightarrow ERLE = ERLE_{rcvref} - ERLE_{rcv} - Bo - JLR_{rcv} - Ain - Ercv - Ao - JLR_{snd} - Bin</math></p> <p>1) Before receiving/ANS; ECon <math>\Rightarrow ERLE &gt; 25</math> dB            2) After the receiving/ANS; ECoff <math>\Rightarrow ERLE &gt; 1</math> dB</p>
<b>Note:</b>	

<b>Test number</b>	<b>2.1.1.4; /ANSam (from A) + C16</b>
<b>Measurement procedure</b>	<ul style="list-style-type: none"> <li>Establishing a new call from B to A and reset EC</li> <li>Apply signal C16 to Interface B and determine <math>ERLE_{RCVREF}</math></li> <li>Establishing a new call from B to A and reset EC</li> <li>Apply signal ANSam to Interface A</li> <li>Apply signal C16 to Interface B and determine <math>ERLE_{RCV}</math> after sending ANS (from A)</li> </ul>
<b>Requirement</b>	<p>Establishing a new call from B to A the EC is active (EC on).  After the receiving/ANSam from A, the EC will change the state (EC off).  <math>\Rightarrow ERLE = ERLE_{rcvref} - ERLE_{rcv} - Bo - JLR_{rcv} - Ain - Ercv - Ao - JLR_{snd} - Bin</math></p> <ol style="list-style-type: none"> <li>Before receiving/ANSam; <math>ECon \Rightarrow ERLE &gt; 25</math> dB</li> <li>After the receiving/ANSam; <math>ECoft \Rightarrow ERLE &gt; 1</math> dB</li> </ol>
<b>Note:</b>	

### B.3.2.2 Answer tones + first fax frame + C16

<b>Test number</b>	<b>2.1.2.1; ANS (from A) + FAX (from B) + C16</b>
<b>Measurement procedure</b>	<ul style="list-style-type: none"> <li>Establishing a new call from B to A and reset EC</li> <li>Apply signal C16 to Interface B and determine <math>ERLE_{RCVREF}</math></li> <li>Establishing a new call from B to A and reset EC</li> <li>Apply signal ANS to Interface A</li> <li>Apply signal FAX to Interface A</li> <li>Apply signal C16 to Interface B and determine <math>ERLE_{RCV}</math> after sending ANS (from A)</li> </ul>
<b>Requirement</b>	<p>Establishing a new call from B to A the EC is active (EC on).  After the receiving ANS from A, the EC will not change the state (EC on).  <math>\Rightarrow ERLE = ERLE_{rcvref} - ERLE_{rcv} - Bo - JLR_{rcv} - Ain - Ercv - Ao - JLR_{snd} - Bin</math></p> <ol style="list-style-type: none"> <li>Before receiving ANS; <math>ECon \Rightarrow ERLE &gt; 25</math> dB</li> <li>After the receiving ANS; <math>ECon \Rightarrow ERLE &gt; 25</math> dB</li> </ol>
<b>Note:</b>	

<b>Test number</b>	<b>2.1.2.2; ANSam (from A)+ FAX (from A)+ C16</b>
<b>Measurement procedure</b>	<ul style="list-style-type: none"> <li>Establishing a new call from B to A and reset EC</li> <li>Apply signal C16 to Interface B and determine <math>ERLE_{RCVREF}</math></li> <li>Establishing a new call from B to A and reset EC</li> <li>Apply signal ANS to Interface A</li> <li>Apply signal FAX to Interface A</li> <li>Apply signal C16 to Interface B and determine <math>ERLE_{RCV}</math> after sending ANSam (from A)</li> </ul>
<b>Requirement</b>	<p>Establishing a new call from B to A the EC is active (EC on).  After the receiving ANSam from A, the EC will not change the state (EC on).  <math>\Rightarrow ERLE = ERLE_{rcvref} - ERLE_{rcv} - Bo - JLR_{rcv} - Ain - Ercv - Ao - JLR_{snd} - Bin</math></p> <ol style="list-style-type: none"> <li>Before receiving ANSam; <math>ECon \Rightarrow ERLE &gt; 25</math> dB</li> <li>After the receiving ANSam; <math>ECon \Rightarrow ERLE &gt; 25</math> dB</li> </ol>
<b>Note:</b>	

<b>Test number</b>	<b>2.1.2.3; /ANS (from A) + FAX (from A)+ C16</b>
<b>Measurement procedure</b>	<ul style="list-style-type: none"> <li>Establishing a new call from B to A and reset EC</li> <li>Apply signal C16 to Interface B and determine <math>ERLE_{RCVREF}</math></li> <li>Establishing a new call from B to A and reset EC</li> <li>Apply signal ANS to Interface A</li> <li>Apply signal FAX to Interface A</li> <li>Apply signal C16 to Interface B and determine <math>ERLE_{RCV}</math> after sending/ANS (from A)</li> </ul>
<b>Requirement</b>	<p>Establishing a new call from B to A the EC is active (EC on).          After the receiving/ANS from A, the EC will not change the state (EC off).  <math>\Rightarrow ERLE = ERLE_{rcvref} - ERLE_{rcv} - Bo - JLR_{rcv} - Ain - Ercv - Ao - JLR_{snd} - Bin</math></p> <p>1) Before receiving/ANS; <math>ECon \Rightarrow ERLE &gt; 25</math> dB          2) After the receiving/ANS; <math>ECoft \Rightarrow ERLE &gt; 1</math> dB</p>
<b>Note:</b>	

<b>Test number</b>	<b>2.1.2.4; /ANSam (from A) + FAX (from A)+C16</b>
<b>Measurement procedure</b>	<ul style="list-style-type: none"> <li>Establishing a new call from B to A and reset EC</li> <li>Apply signal C16 to Interface B and determine <math>ERLE_{RCVREF}</math></li> <li>Establishing a new call from B to A and reset EC</li> <li>Apply signal ANSam to Interface A</li> <li>Apply signal FAX to Interface A</li> <li>Apply signal C16 to Interface B and determine <math>ERLE_{RCV}</math> after sending/ANSam (from A)</li> </ul>
<b>Requirement</b>	<p>Establishing a new call from B to A the EC is active (EC on).          After the receiving/ANSam from A, the EC will not change the state (EC off).  <math>\Rightarrow ERLE = ERLE_{rcvref} - ERLE_{rcv} - Bo - JLR_{rcv} - Ain - Ercv - Ao - JLR_{snd} - Bin</math></p> <p>1) Before receiving/ANSam; <math>ECon \Rightarrow ERLE &gt; 25</math> dB          2) After the receiving/ANSam; <math>ECoft \Rightarrow ERLE &gt; 1</math> dB</p>
<b>Note:</b>	

### B.3.2.3 Tests with test signals based on the Use of the CI call signal and exchange of CM/JM menu signals + C16

<b>Test number</b>	<b>2.1.3.1; ANSam + 4 x JM/6 x CM + CJ</b>
<b>Measurement procedure</b>	<ul style="list-style-type: none"> <li>Establishing a new call from B to A and reset EC</li> <li>Apply signal C16 to Interface B and determine <math>ERLE_{RCVREF}</math></li> <li>Establishing a new call from B to A and reset EC</li> <li>Apply signal/ANSam + 4 x JM to Interface A, and time-synchronously apply signal 6 x CM + CJ to Interface B</li> <li>Apply signal C16 to Interface B and determine <math>ERLE_{RCV}</math> after sending/ANSam + 4 x JM (from A)</li> </ul>
<b>Requirement</b>	<p>Establishing a new call from B to A the EC is active (EC on).          After the receiving/ANSam from A, the EC will change the state (EC off).  <math>\Rightarrow ERLE = ERLE_{rcvref} - ERLE_{rcv} - Bo - JLR_{rcv} - Ain - Ercv - Ao - JLR_{snd} - Bin</math></p> <p>1) Before receiving/ANSam+ 4 x JM; <math>ECon \Rightarrow ERLE &gt; 25</math> dB          2) After the receiving/ANSam; <math>ECoft \Rightarrow ERLE &gt; 1</math> dB</p>
<b>Note:</b> See figure 1 of Recommendation ITU-T V.8 [1].	



### B.3.2.4 Tests with test signals based on DTMF

#### B.3.2.4.1 Answer tones + D16

<b>Test number</b>	<b>2.1.4.1; ANS (from A) + D16</b>
<b>Measurement procedure</b>	<ul style="list-style-type: none"> <li>• Establishing a new call from B to A and reset EC</li> <li>• Apply signal D16 to Interface B and determine <math>ERLE_{RCVREF}</math></li> <li>• Establishing a new call from B to A and reset EC</li> <li>• Apply signal ANS to Interface A</li> <li>• Apply signal D16 to Interface B and determine <math>ERLE_{RCV}</math> after sending ANS (from A)</li> </ul>
<b>Requirement</b>	<p>Establishing a new call from B to A the EC is active (EC on).            After the receiving ANS from A, the EC will not change the state (EC on)</p> <p>⇒ <math>ERLE = ERLE_{rcvref} - ERLE_{rcv} - Bo - JLR_{rcv} - Ain - Ercv - Ao - JLR_{snd} - Bin</math></p> <ol style="list-style-type: none"> <li>1) Before receiving ANS; <math>ECon \Rightarrow ERLE &gt; 25 \text{ dB}</math></li> <li>2) After the receiving ANS; <math>ECon \Rightarrow ERLE &gt; 25 \text{ dB}</math></li> </ol>
<b>Note:</b>	

<b>Test number</b>	<b>2.1.4.2; ANSam (from A) + D16</b>
<b>Measurement procedure</b>	<ul style="list-style-type: none"> <li>• Establishing a new call from B to A and reset EC</li> <li>• Apply signal D16 to Interface B and determine <math>ERLE_{RCVREF}</math></li> <li>• Establishing a new call from B to A and reset EC</li> <li>• Apply signal ANSam to Interface A</li> <li>• Apply signal D16 to Interface B and determine <math>ERLE_{RCV}</math> after sending ANS (from A)</li> </ul>
<b>Requirement</b>	<p>Establishing a new call from B to A the EC is active (EC on).            After the receiving ANSam from A, the EC will not change the state (EC on).</p> <p>⇒ <math>ERLE = ERLE_{rcvref} - ERLE_{rcv} - Bo - JLR_{rcv} - Ain - Ercv - Ao - JLR_{snd} - Bin</math></p> <ol style="list-style-type: none"> <li>1) Before receiving ANSam; <math>ECon \Rightarrow ERLE &gt; 25 \text{ dB}</math></li> <li>2) After the receiving ANSam; <math>ECon \Rightarrow ERLE &gt; 25 \text{ dB}</math></li> </ol>
<b>Note:</b>	

<b>Test number</b>	<b>2.1.4.3; /ANS (from A) + D16</b>
<b>Measurement procedure</b>	<ul style="list-style-type: none"> <li>• Establishing a new call from B to A and reset EC</li> <li>• Apply signal D16 to Interface B and determine <math>ERLE_{RCVREF}</math></li> <li>• Establishing a new call from B to A and reset EC</li> <li>• Apply signal/ANS to Interface A</li> <li>• Apply signal D16 to Interface B and determine <math>ERLE_{RCV}</math> after sending/ANS (from A)</li> </ul>
<b>Requirement</b>	<p>Establishing a new call from B to A the EC is active (EC on).            After the receiving/ANS from A, the EC will change the state (EC off).</p> <p>⇒ <math>ERLE = ERLE_{rcvref} - ERLE_{rcv} - Bo - JLR_{rcv} - Ain - Ercv - Ao - JLR_{snd} - Bin</math></p> <ol style="list-style-type: none"> <li>1) Before receiving/ANS; <math>ECon \Rightarrow ERLE &gt; 25 \text{ dB}</math></li> <li>2) After the receiving/ANS; <math>ECoff \Rightarrow ERLE &gt; 1 \text{ dB}</math></li> </ol>
<b>Note:</b>	

<b>Test number</b>	<b>2.1.4.4; /ANSam (from A) + D16</b>
<b>Measurement procedure</b>	<ul style="list-style-type: none"> <li>Establishing a new call from B to A and reset EC</li> <li>Apply signal D16 to Interface B and determine <math>ERLE_{RCVREF}</math></li> <li>Establishing a new call from B to A and reset EC</li> <li>Apply signal/ANSam to Interface A</li> <li>Apply signal D16 to Interface B and determine <math>ERLE_{RCV}</math> after sending/ANSam (from A)</li> </ul>
<b>Requirement</b>	<p>Establishing a new call from B to A the EC is active (EC on). After the receiving/ANSam from A, the EC will change the state (EC off).</p> <p>⇒ <math>ERLE = ERLE_{rcvref} - ERLE_{rcv} - Bo - JLR_{rcv} - Ain - Ercv - Ao - JLR_{snd} - Bin</math></p> <ol style="list-style-type: none"> <li>Before receiving/ANSam; <math>ECon \Rightarrow ERLE &gt; 25</math> dB</li> <li>After the receiving/ANSam; <math>ECoft \Rightarrow ERLE &gt; 1</math> dB</li> </ol>
<b>Note:</b>	

### B.3.2.5 Tests with test signals based on the Use of the CI call signal and exchange of CM/JM menu signals + D16

<b>Test number</b>	<b>2.1.5.1; /ANSam + 4 × JM/6 × CM + CJ</b>
<b>Measurement procedure</b>	<ul style="list-style-type: none"> <li>Establishing a new call from B to A and reset EC</li> <li>Apply signal D16 to Interface B and determine <math>ERLE_{RCVREF}</math></li> <li>Establishing a new call from B to A and reset EC</li> <li>Apply signal/ANSam + 4 × JM to Interface A, and time-synchronously apply signal 6 × CM + CJ to Interface B</li> <li>Apply signal D16 to Interface B and determine <math>ERLE_{RCV}</math> after sending/ANSam + 4 × JM (from A)</li> </ul>
<b>Requirement</b>	<p>Establishing a new call from B to A the EC is active (EC on). After the receiving/ANSam from A, the EC will change the state (EC off).</p> <p>⇒ <math>ERLE = ERLE_{rcvref} - ERLE_{rcv} - Bo - JLR_{rcv} - Ain - Ercv - Ao - JLR_{snd} - Bin</math></p> <ol style="list-style-type: none"> <li>Before receiving/ANSam+ 4 × JM; <math>ECon \Rightarrow ERLE &gt; 25</math> dB</li> <li>After the receiving/ANSam; <math>ECoft \Rightarrow ERLE &gt; 1</math> dB</li> </ol>
<b>Note:</b> See figure 3.	

## B.4 Tests with test signals based on the data rate change between V.34 and V.17 Fax Terminals

<b>Test number</b>	<b>3.1.1 /ANSam + 4 × JM/6 × CM + CJ data rate change between V.34 and V.17 Fax Terminals</b>
<b>Measurement procedure</b>	<ul style="list-style-type: none"> <li>Establishing a new call from A to B and reset EC</li> <li>Apply signal D16 to Interface A and determine <math>ERLE_{RCVREF}</math></li> <li>Establishing a new call from A to B and reset EC</li> <li>Apply signal/ANSam + 4 × JM to Interface B, and time-synchronously apply signal 6 × CM + CJ to Interface A</li> <li>Apply signal D16 to Interface A and determine <math>ERLE_{RCV}</math> after sending/ANSam + 4 × JM (from B)</li> <li>After 400 ms signal break apply signal C16 to Interface A and determine <math>ERLE_{RCV}</math></li> </ul>
<b>Requirement</b>	<p>Establishing a new call from A to B the EC is active (EC on). After the receiving/ANSam from B, the EC will change the state (EC off).</p> <p>⇒ <math>ERLE = ERLE_{rcvref} - ERLE_{rcv} - Bo - JLR_{rcv} - Ain - Ercv - Ao - JLR_{snd} - Bin</math></p> <ol style="list-style-type: none"> <li>Before receiving/ANSam+ 4 × JM; <math>ECon \Rightarrow ERLE &gt; 25</math> dB</li> <li>After the receiving/ANSam; <math>ECoft \Rightarrow ERLE &gt; 1</math> dB</li> <li>After 400 ms signal break <math>ECon \Rightarrow ERLE &gt; 25</math> dB</li> </ol>
<b>Note:</b> See figure 3.	

<b>Test number</b>	<b>3.1.2 /ANSam + 4 x JM/6 x CM + CJ, data rate change between V.34 and V.17 Fax Terminals</b>
<b>Measurement procedure</b>	<ul style="list-style-type: none"> <li>Establishing a new call from B to A and reset EC</li> <li>Apply signal C16 to Interface B and determine <math>ERLE_{RCVREF}</math></li> <li>Establishing a new call from B to A and reset EC</li> <li>Apply signal/ANSam + 4 x JM to Interface A, and time-synchronously apply signal 6 x CM + CJ to Interface B</li> <li>Apply signal C16 to Interface B and determine <math>ERLE_{RCV}</math> after sending/ANSam + 4 x JM (from A)</li> <li>After 400 ms signal break apply signal C16 to Interface B and determine <math>ERLE_{RCV}</math></li> </ul>
<b>Requirement</b>	<p>Establishing a new call from B to A the EC is active (EC on).          After the receiving/ANSam from A, the EC will change the state (EC off).  <math>\Rightarrow ERLE = ERLE_{rcvref} - ERLE_{rcv} - Bo - JLR_{rcv} - A_{in} - E_{rcv} - A_o - JLR_{snd} - B_{in}</math></p> <ol style="list-style-type: none"> <li>Before receiving/ANSam+ 4 x JM; ECon <math>\Rightarrow ERLE &gt; 25</math> dB</li> <li>After the receiving/ANSam; ECoFF <math>\Rightarrow ERLE &gt; 1</math> dB</li> <li>After 400 ms signal break ECon <math>\Rightarrow ERLE &gt; 25</math> dB</li> </ol>
<b>Note:</b> See figure 3.	

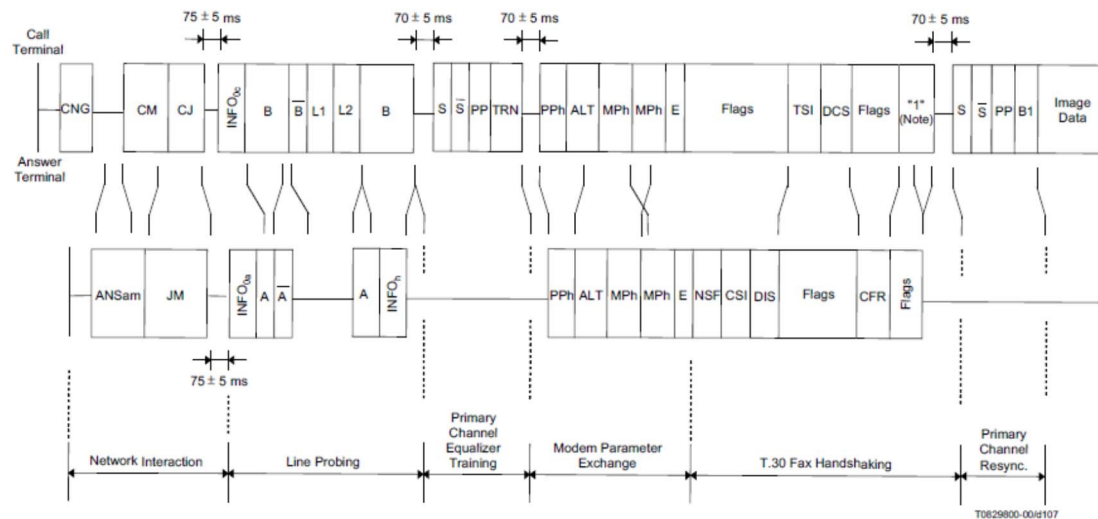

NOTE – The string of consecutive 1s shall be followed by the 4T of scrambled ones defined in 12.6.3/V.34.

**Figure B.4: Typical V.34 fax start-up sequence**

---

## Annex C (informative): Features of V.17 Fax and V.34 Fax

### C.1 Features of V.17 Fax (V.17 Fax Modem)

- Half-duplex mode of operation for fax applications.
- QAM is used for the channel with synchronous line transmission at 2 400 baud.
- Data signalling rates: 14 400 bps, 12 000 bps, 9 600 bps, 7 200 bps, 4 800 bps and 2 400 bps synchronous.
- Trellis coding at rates from 7 200 bps to 14 000 bps.
- Exchange of rate sequences is provided during start-up to establish the data-rate, coding, and any other special facilities.
- The frequency carrier operates at 1 800 Hz.
- Transmitted power levels conform to V.2.
- Modulation rate is 2 400 symbols/s.
- Supports V.24 interchange circuits.

---

### C.2 V.34 High-Speed Fax

#### C.2.1 Features

- Fully compliant Group 3 Facsimile Support.
- Full and half duplex modes.
- Primary data channel supports 14 data rates in the range of 2 400 bps to 33 600 bps, in increments of 2 400 bps.
- Control channel rates are 1 200 bps and 2 400 bps.

#### C.2.2 The Recommendation ITU-T V.34 Fax Standard

The V.34 fax standard was derived from the V.34 data modem standard established by the International Telecommunications Union (ITU). The V.34 data modem standard is a full-duplex implementation for sending and receiving data across telephone lines with a maximum data rate of 33,6 Kbps. Certain elements of the V.34 data modem standard were eliminated for V.34 fax while new features, such as a control channel and mandatory ECM, were added to enable fast and reliable fax transmission.

Data Rates Supported (Kbps)	ITU Standard		
	V.27 V.29	V.17	V.34
2,4	X		X
4,8	X		X
7,2	X	X	X
9,6	X	X	X
12		X	X
14,4		X	X
16,8			X
19,2			X
21,6			X
24			X
26,4			X
28,8			X
31,2			X
33,6			X

Figure C.1: Comparison between Fax Modulation Speeds

### C.3 The V.34 Fax Connection and Session

In order to understand the benefits of the V.34 fax standard, it is first necessary to understand how a fax transmission works. V.34 session management and setup were designed with a similar mechanism to legacy handshaking procedures. The first step of a fax session is to establish a "handshake" between the sending and the receiving devices. During handshaking, the sending and receiving devices negotiate key parameters for how the fax call should be set up such as determining what is the highest transmission speed supported by both devices. The handshaking process itself is performed at 300 bps in legacy devices. In V.34 fax capable devices, handshaking is performed at a much faster data rate of 1,2 Kbps. The result is a handshake time that is reduced from approximately 16 seconds of legacy systems to 9 seconds for V.34.

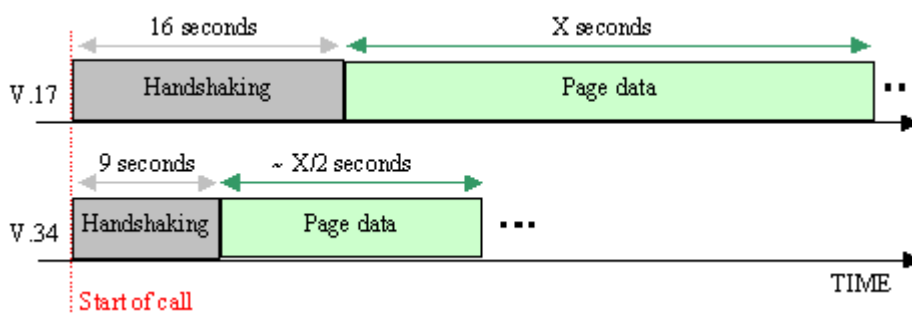

Figure C.2: Time-wise Comparison Between V.34 and V.17 Fax

After handshaking is complete, the next stage of a fax session is the transmission of the actual fax page data. The retraining and re-synchronization process takes place after each page is transmitted in legacy schemes, where capabilities such as supported modulation and transfer are renegotiated. In case of error in the transmission, entire pages may need to be retransmitted. This cycle of page data retrain and retransmit repeats until the fax call is completed, and account for significant inefficiency of legacy fax machines. V.34 provides the most extensive range of supported data transmission rates, allowing it to optimize both speed and reliability over a wide range of line conditions. With V.34, fax page data is transmitted at 33,6 Kbps, twice the speed of V.17. In addition, V.34 uses ECM (Error Correction Mode) as a mandatory feature that handles page transmission error in a much more efficient way.

## C.4 ECM as a Mandatory Feature

ECM is a mandatory feature for V.34 fax as opposed to V.17, where it is optional. The ECM protocol was designed to automatically detect and correct errors in the fax transmission process caused by factors such as telephone line noise. The page data to be transferred is divided into small blocks of data called Octets. Once all octets are received, they are examined using check-sums.

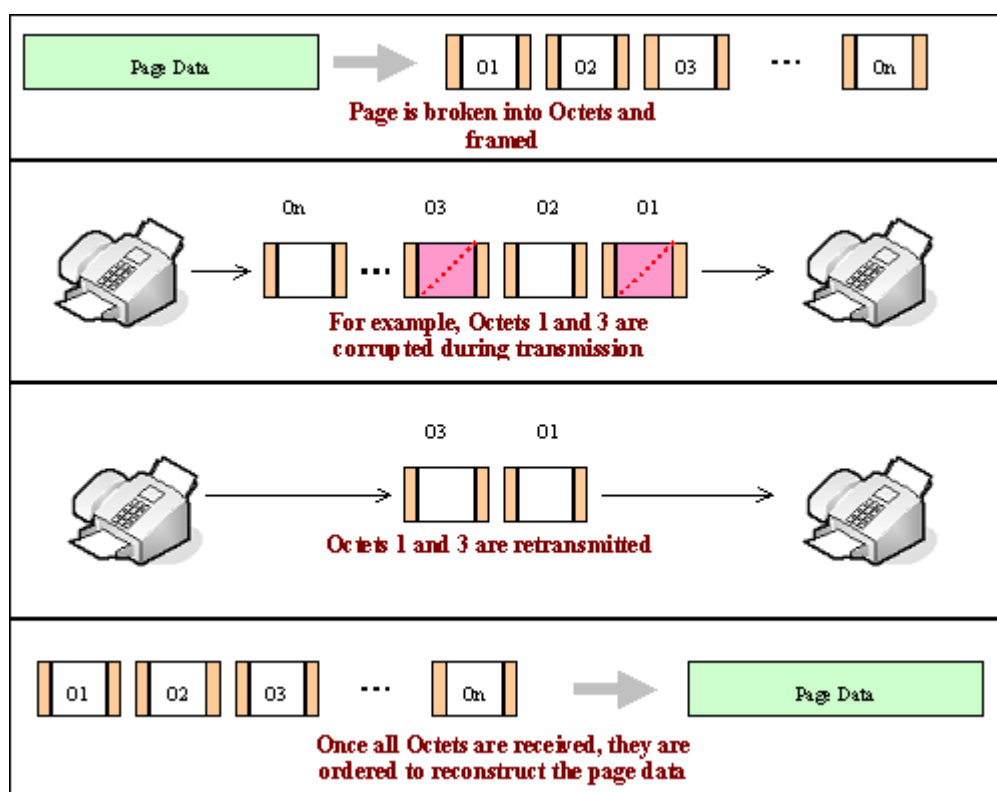

Figure C.3: ECM Enabled Fax Transmission

If any errors in the checksums are detected, the receiving fax device signals the transmitting fax device to retransmit the octets that were received incorrectly. The transmitter then retransmits only the needed blocks rather than the whole page. Once, all octets are received correctly, they are ordered and the page data is reconstructed by removing the octet frame and signalling flags. Generally, this results in a faster and more successful fax transmission than in a scenario where entire page data is retransmitted once or multiple times.

Introduction to V.34 High-Speed Fax [i.8]. Website: <http://www.gaoresearch.com/V34Fax/V34Fax.php>.

---

# History

<b>Document history</b>		
V1.1.1	April 2011	Publication
V2.1.1	August 2012	Publication
V2.1.2	March 2013	Publication
V2.2.1	October 2015	Publication