

# ETSI TS 102 928 V1.1.2 (2014-05)



Technical Specification

**Speech and multimedia Transmission Quality (STQ);  
End-to-End Transmission Planning Requirements for  
Real Time Services in an NGN context**

---

**Reference**

RTS/STQ-228

---

**Keywords**

planning, QoS, transmission, voice

**ETSI**

---

650 Route des Lucioles  
F-06921 Sophia Antipolis Cedex - FRANCE

Tel.: +33 4 92 94 42 00 Fax: +33 4 93 65 47 16

Siret N° 348 623 562 00017 - NAF 742 C  
Association à but non lucratif enregistrée à la  
Sous-Préfecture de Grasse (06) N° 7803/88

---

**Important notice**

The present document can be downloaded from:

<http://www.etsi.org>

The present document may be made available in electronic versions and/or in print. The content of any electronic and/or print versions of the present document shall not be modified without the prior written authorization of ETSI. In case of any existing or perceived difference in contents between such versions and/or in print, the only prevailing document is the print of the Portable Document Format (PDF) version kept on a specific network drive within ETSI Secretariat.

Users of the present document should be aware that the document may be subject to revision or change of status. Information on the current status of this and other ETSI documents is available at

<http://portal.etsi.org/tb/status/status.asp>

If you find errors in the present document, please send your comment to one of the following services:

[http://portal.etsi.org/chaicor/ETSI\\_support.asp](http://portal.etsi.org/chaicor/ETSI_support.asp)

---

**Copyright Notification**

No part may be reproduced or utilized in any form or by any means, electronic or mechanical, including photocopying and microfilm except as authorized by written permission of ETSI.

The content of the PDF version shall not be modified without the written authorization of ETSI.

The copyright and the foregoing restriction extend to reproduction in all media.

© European Telecommunications Standards Institute 2014.

All rights reserved.

**DECT™**, **PLUGTESTS™**, **UMTS™** and the ETSI logo are Trade Marks of ETSI registered for the benefit of its Members. **3GPP™** and **LTE™** are Trade Marks of ETSI registered for the benefit of its Members and of the 3GPP Organizational Partners.

**GSM®** and the GSM logo are Trade Marks registered and owned by the GSM Association.

# Contents

Intellectual Property Rights .....	4
Foreword.....	4
Introduction .....	4
1 Scope .....	5
2 References .....	5
2.1 Normative references .....	5
2.2 Informative references.....	5
3 Definitions and abbreviations.....	6
3.1 Definitions.....	6
3.2 Abbreviations .....	7
4 Reference Configuration .....	8
4.1 Generic Segment-connection Points.....	9
4.2 Transport Reference Parameters and Configurations .....	10
4.2.1 Reference Configurations .....	11
4.2.1.1 Backbone Configuration .....	11
4.2.1.2 PSTN/ISDN classic access Configuration .....	11
4.2.1.3 NGN PSTN/ISDN access Configuration .....	11
4.2.1.4 Access DSL/Ethernet Configuration .....	11
4.2.1.5 GSM Access configuration .....	12
4.2.1.6 Access configuration from UMTS Release 4.....	12
4.2.1.7 Access configuration from LTE.....	12
4.2.1.8 CPE reference configuration .....	13
4.3 Delay Values .....	13
4.3.1 Backbone Delay.....	14
4.4 Network parameters: End-to-End Delay, Talker Echo Loudness Rating, R Value for VoIP .....	16
4.4.1 Delay with regional propagation delay (1 400 km / 7 ms).....	16
4.4.2 Categories of User Satisfaction.....	20
5 Guidance on Segment-connection Objectives.....	20
5.1 Guidance on Access Segment Objectives .....	21
5.2 Guidance on Total Transit Segment Objectives .....	21
5.2.1 Availability .....	22
5.3 Voice Terminals .....	22
6 End-to-End Aspects.....	22
7 Transport of UDI.....	24
8 Synchronization of endpoints.....	24
History .....	26

---

## Intellectual Property Rights

IPRs essential or potentially essential to the present document may have been declared to ETSI. The information pertaining to these essential IPRs, if any, is publicly available for **ETSI members and non-members**, and can be found in ETSI SR 000 314: "*Intellectual Property Rights (IPRs); Essential, or potentially Essential, IPRs notified to ETSI in respect of ETSI standards*", which is available from the ETSI Secretariat. Latest updates are available on the ETSI Web server (<http://ipr.etsi.org>).

Pursuant to the ETSI IPR Policy, no investigation, including IPR searches, has been carried out by ETSI. No guarantee can be given as to the existence of other IPRs not referenced in ETSI SR 000 314 (or the updates on the ETSI Web server) which are, or may be, or may become, essential to the present document.

---

## Foreword

This Technical Specification (TS) has been produced by ETSI Technical Committee Speech and multimedia Transmission Quality (STQ).

---

## Introduction

The present document provides end-to-end transmission planning requirements for voice (from mouth to ear) and voice band data services in a context of an IP Multimedia Core Network Subsystem, and partially extracted from, TR 102 775 [i.20]. Focus is on details of delay introduced by network elements, jitter caused by access bandwidth limitations and on reference connection scenarios. The objectives provided are a pre-requisite for network operators to be able to provide good quality connections as perceived by the user. The present document forms part of STQ's roadmap regarding Quality aspects of the IP Multimedia Core Network Subsystem.

---

# 1 Scope

The present document provides requirements on the quality parameters that need to be considered at the Segment-connection of Voice over IP (VoIP) services, voice band data (VBD) and conversational video service services in an IP Multimedia Core Network Subsystem. The present document provides requirements on objectives for voice and data parameters.

---

# 2 References

References are either specific (identified by date of publication and/or edition number or version number) or non-specific. For specific references, only the cited version applies. For non-specific references, the latest version of the reference document (including any amendments) applies.

Referenced documents which are not found to be publicly available in the expected location might be found at <http://docbox.etsi.org/Reference>.

NOTE: While any hyperlinks included in this clause were valid at the time of publication, ETSI cannot guarantee their long term validity.

## 2.1 Normative references

The following referenced documents are necessary for the application of the present document.

Not applicable.

## 2.2 Informative references

The following referenced documents are not necessary for the application of the present document but they assist the user with regard to a particular subject area.

- [i.1] Recommendation ITU-T Y.1540 (2002): "Internet protocol data communication service - IP packet transfer and availability performance parameters".
- [i.2] Recommendation ITU-T Y.1541 (2006): "Network performance objectives for IP-based services".
- [i.3] Recommendation ITU-T Y.1542 (2006): "Framework for achieving end-to-end IP performance objectives".
- [i.4] Recommendation ITU-T G.107 (2008): "The E-model: a computational model for use in transmission planning".
- [i.5] Recommendation ITU-T G.109 (1999): "Definition of categories of speech transmission quality".
- [i.6] ETSI ES 202 737: "Speech and multimedia Transmission Quality (STQ); Transmission requirements for narrowband VoIP terminals (handset and headset) from a QoS perspective as perceived by the user".
- [i.7] ETSI ES 202 738: "Speech and multimedia Transmission Quality (STQ); Transmission requirements for narrowband VoIP loudspeaking and handsfree terminals from a QoS perspective as perceived by the user".
- [i.8] ETSI ES 202 739: "Speech and multimedia Transmission Quality (STQ); Transmission requirements for wideband VoIP terminals (handset and headset) from a QoS perspective as perceived by the user".
- [i.9] ETSI ES 202 740: "Speech and multimedia Transmission Quality (STQ); Transmission requirements for wideband VoIP loudspeaking and handsfree terminals from a QoS perspective as perceived by the user".

- [i.10] ETSI ES 282 001: "Telecommunications and Internet converged Services and Protocols for Advanced Networking (TISPAN); NGN Functional Architecture".
- [i.11] GSMA Document IR.3445: "Inter-Service Provider IP Backbone Guidelines".
- [i.12] Recommendation ITU-T G.8261 (2008): "Timing and synchronization aspects in packet networks".
- [i.13] Recommendation ITU-T G.8262 (2007): "Timing characteristics of synchronous ethernet equipment slave clock (EEC)".
- [i.14] Recommendation ITU-T G.8264 (2008): "Timing distribution through packet networks".
- [i.15] IEEE 1588: "Standard for a Precision Clock Synchronization Protocol for Networked Measurement and Control System".
- [i.16] Recommendation ITU-T G.711: "Pulse code modulation (PCM) of voice frequencies".
- [i.17] Recommendation ITU-T G.729: "Coding of speech at 8 kbit/s using conjugate-structure algebraic-code-excited linear prediction (CS-ACELP)".
- [i.18] Recommendation ITU-T I.231.1: "Circuit-mode bearer service categories: Circuit-mode 64 kbit/s unrestricted, 8 kHz structured bearer service".
- [i.19] Recommendation ITU-T G.826: "End-to-end error performance parameters and objectives for international, constant bit-rate digital paths and connections".
- [i.20] ETSI TR 102 775: "Speech and multimedia Transmission Quality (STQ); Guidance on objectives for Quality related Parameters at VoIP Segment-Connection Points; A support to NGN transmission planners".
- [i.21] Recommendation ITU-T G.813: "Timing characteristics of SDH equipment slave clocks (SEC)".

---

## 3 Definitions and abbreviations

### 3.1 Definitions

For the purposes of the present document, the following terms and definitions apply:

**access segment:** network segment from the customer interface (UNI) to the interface on the customer side of the first Gateway Router

**real time service:** class of telecommunications service requiring information to be transmitted and delivered within stated limits of time delay and jitter

**segment-connection point:** point between two segments

NOTE: The terms "interconnection" or "interconnection point" has been used in the NGN standards, e.g. in [i.14], the same terms are generally used for NNIs, not for the connection between access segment and transit segment, they might be misinterpreted. Therefore, throughout the present document, the terms "Segment-connection" or "Segment-connection point" are used.

**total transit segment:** segment between Gateway routers, including the gateway routers themselves

NOTE: The network segment may include interior routers having different functions.

## 3.2 Abbreviations

For the purposes of the present document, the following abbreviations apply:

ADM	Add-Dropp-Multiplexer
ADSL	Asymmetric Digital Subscriber Line
AGW	Access GateWay
AS	Application Server
ATM	Asynchronous Transfer Mode
BRAS	Broadband Remote Access Server
BSC	Base Station Controller
BTS	Base Transceiver Station
CL	router Core Layer
CPE	Customer Premises Equipment
DL	router Distribution Layer
DSL	Digital Subscriber Line
DSLAM	Digital Subscriber Line Access Multiplexer
EC	Echo Canceller
eNodeB	evolved Node B
ETH	ETHernet
GERAN	GSM EDGE Radio Access Network
GGSN	Gateway GPRS Support Node
GSM	Global System for Mobile communications
GSMA	Global System for Mobile communications Association
GW	GateWay
HSS	Home Subscriber Server
IAD	Integrated Access Device
Ie	Equipment Impairment Factor
IMS	IP Multimedia Subsystem
IP	Internet Protocol
IPDV	IP packet Delay Variation
IPER	IP packet Error Ratio
IPLR	IP packet Loss Ratio
IPTD	IP packet Transfer Delay
ISDN	Integrated Services Digital Network
ITU	International Telecommunication Union
ITU-T	ITU Telecommunication Standardization Sector
JB	De-jitter Buffer
LAN	Local Area Network
MGW	Media GateWay
MME	Mobility Management Entity
MOS	Mean Opinion Score
MSAN	Multi Service Access Node
MSC	Mobile Switching Centre
NGN	Next Generation Network
NNI	Network to Network Interface
NTP	Network Time Protocol
PCRF	Policy and Charging Rules Function
P-CSCF	Proxy Call Session Control Function
PGW	PDN GateWay
PSTN	Public Switched Telephone Network
PTP	Precision Time Protocol
QoS	Quality of Service
RAN	Radio Access Network
RGW	Residential GateWay
SBC	Session Border Controller
SGSN	Serving GPRS Support Node
SGW	Serving GateWay
SIP	Session Initiation Protocol
SoIx	Service-oriented Interconnection
STM 1	Synchronous Transport Module 1

STM	Synchronous Transfer Mode
SyncE	Synchronous Ethernet
TRAU	Transcoder and Rate Adaption Unit
UE	User equipment
UMSC	UMTS Mobile Switching Centre
UMTS	Universal Mobile Telecommunications System
UNI	User Network Interface
UNI <sub>A</sub>	User Network Interface A
UNI <sub>C</sub>	User Network Interface C
UTRAN	UMTS Terrestrial Radio Access Network
VBD	Voice Band Data
VCC	Voice Call Continuity
VoIP	Voice over Internet Protocol
xDSL	x Digital Subscriber Line

## 4 Reference Configuration

Compared to networks and systems that are circuit-based, those based on IP pose distinctly different challenges for planning and achieving the end-to-end performance levels necessary to adequately support the wide array of user applications (voice, data, fax, video, etc.). The fundamental quality objectives for these applications are well understood and have not changed as perceived by the user; what has changed is the technology (and associated impairments) in the layers below these applications. The very nature of IP-based routers and terminals, with their queuing methods and de-de-jitter buffers, respectively, makes realizing good end-to-end performance across multiple network operators a very major challenge for applications with stringent performance objectives. Fortunately Recommendations ITU-T Y.1540 [i.1] and Y.1541 [i.2] together provide the parameters needed to capture the performance of IP networks, and specify a set of "network QoS" classes with end-to-end objectives specified. It is widely accepted (i.e. beyond the ITU-T) that the network QoS classes of Recommendation ITU-T Y.1541 [i.2] should be supported by Next Generation Networks, and thus by networks evolving into NGNs. Recommendation ITU-T Y.1542 [i.3] considers various approaches toward achieving end-to-end (UNI-UNI) IP network performance objectives.

The general reference configuration for the present document follows the principles shown in figure 1; the number of concatenated transit providers may vary.

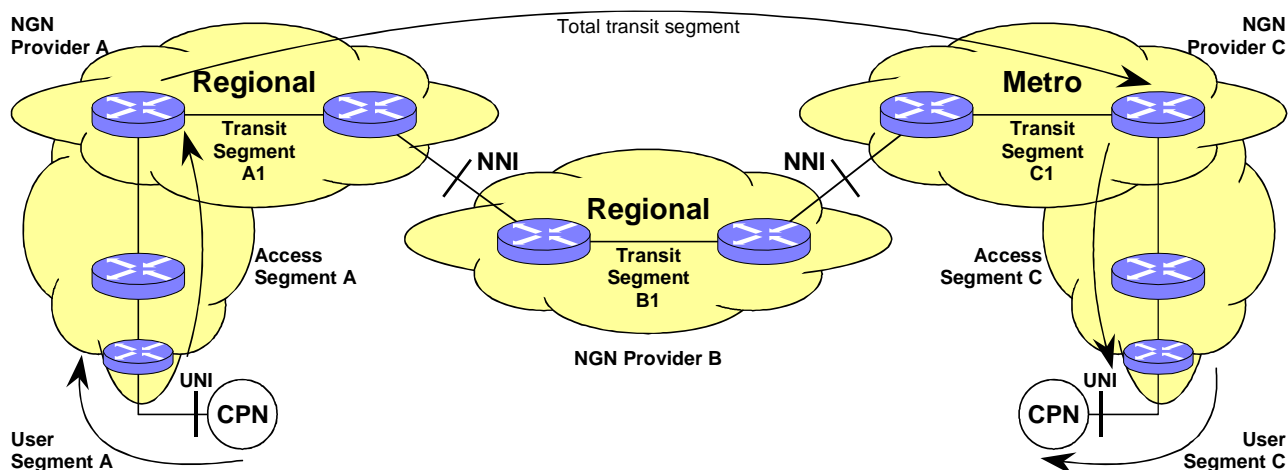

**Figure 1: General Reference Configuration**

- The end-to-end connection can be decomposed into the User segment A.
- UNI<sub>A</sub> (sending side).
- Access segment A.
- Segment-connection Point A<sub>in</sub>.



- Total transit segment.
- Segment-connection Point Cout.
- Access segment C.
- UNI<sub>C</sub> (receiving side).
- User segment C.

The total transit segment can be further decomposed into:

- Transit segment A1.
- Segment-connection point Aout.
- Transit segment A2 (NNI).
- Segment-connection point Bin.
- Transit segment B1.
- Segment-connection point Bout.
- Transmit segment B2 (NNI).
- Segment-connection point Cin.
- Transit segment C1.

## 4.1 Generic Segment-connection Points

Due to real-world constraints the simplified **static divisor** approach according to Recommendation ITU-T Y.1542 [i.3] has been chosen for the impairment apportionment between access and transit networks.

This approach "divides" the UNI-to-UNI path into three segments and budgets the impairments such that the total objective is met in principle.

As outlined in ES 282 001 [i.10] the delay values for the total transit segment are in a fixed relation to the distances between different geographical regions (see table 2). Thus, for the near future dynamic allocation of delay budgets is not expected to be implemented between user segments, access segments and transit segments.

In figure 2, the upper part displays the division of the connection as seen from a QoS point of view whereas the lower part shows this division in terms of the NGN Functional Architecture Recommendation ITU-T G.8264 [i.14].

NOTE: The reference points Ic, Iw, and Iz are defined in Recommendation ITU-T G.8264 [i.14] in clause 7.2.2.

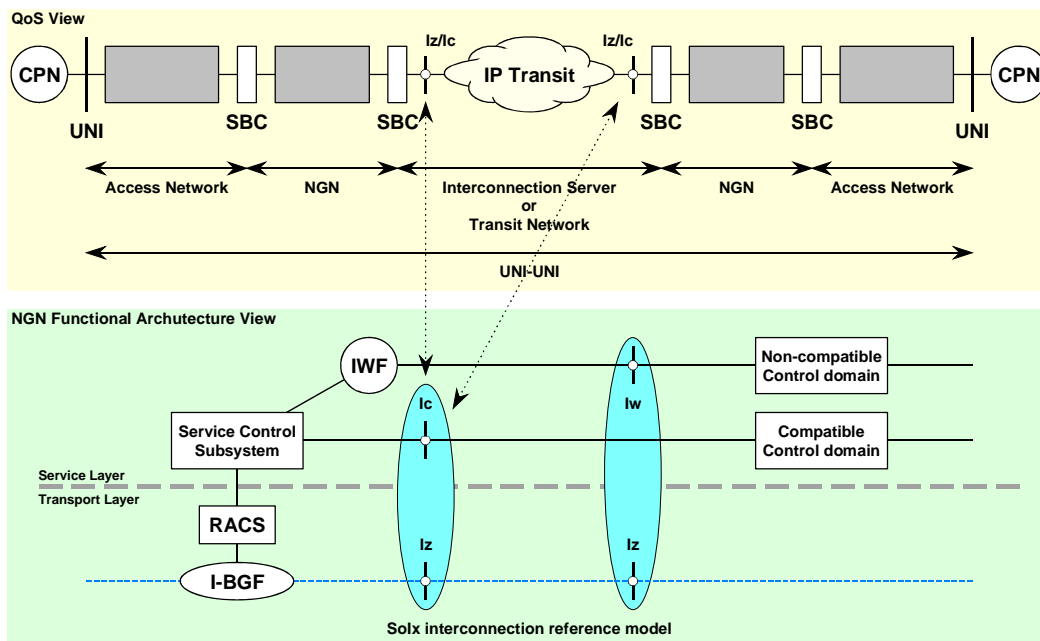

Figure 2: Division of the connection

There should be objectives for the following portions of the connection:

- UNI (send side)  $\leftrightarrow$  Segment-connection Point A.
- Segment-connection Point A  $\leftrightarrow$  Segment-connection Point C.
- Segment-connection Point C  $\leftrightarrow$  UNI (receive side).

As illustrated in figure 2, SoIx interconnection is typically characterized by the presence of two types of information exchanged between the two interconnected domains:

- Service-related signalling information, that allows to identify the end-to-end service that has been requested. For example, in case of IMS-to-IMS SoIx interconnection, this is mapped to SIP signalling on the Ic reference point.
- Transport information that carries the bearer traffic.

The presence of the service-related signalling in SoIx interconnection enables the end-to-end service awareness.

An NGN interconnection could be a SoIx even if the transport information is not exchanged between the interconnected domains, as long as service-related signalling is exchanged.

An NGN transport layer interconnection is considered being part of an NGN SoIx interconnection if the transport layer is controlled from the service layer in both of the interconnected domains.

- **SoIx Interconnection interface** includes at least Ic and Iz reference points between two interconnected domains that have same or compatible service control sub systems/domains.
- **SoIx Interconnection interface with Interworking** includes at least the Iw and Iz reference points between two interconnected domains that have non-compatible service control sub systems/domains.

## 4.2 Transport Reference Parameters and Configurations

At the Segment-connection Points (figure 1) different access networks can be connected. The following access networks can be considered:

- PSTN/ISDN classic access Configuration.
- NGN PSTN/ISDN access Configuration.

- Access DSL Configuration.
- GSM.
- UMTS.
- LTE.

In the following clauses are defined the end-to-end delay, and the Talker Echo Loudness Rating.

## 4.2.1 Reference Configurations

The following clauses describe the Backbone and access reference configuration. In the calculation is at the Segment-connection point taken into account only one SBC.

### 4.2.1.1 Backbone Configuration

Figure 3 shows the backbone configuration.



**Figure 3: Backbone**

### 4.2.1.2 PSTN/ISDN classic access Configuration

Figure 4 shows the PSTN/ISDN classic access configuration.

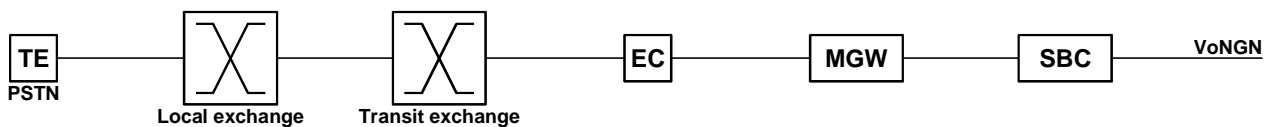

**Figure 4: Reference configuration for PSTN/ISDN with classical access**

### 4.2.1.3 NGN PSTN/ISDN access Configuration

Figure 5 shows the NGN PSTN/ISDN classic access configuration.

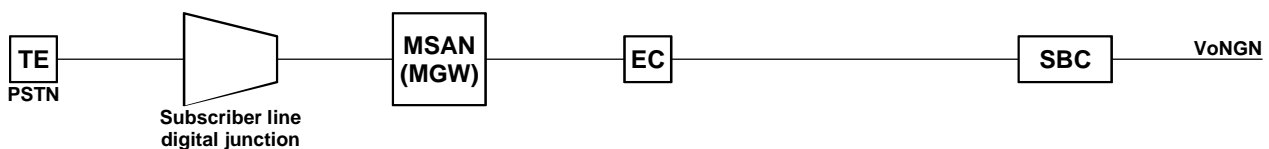

**Figure 5: Reference configuration for NGN with PSTN/ISDN access**

### 4.2.1.4 Access DSL/Ethernet Configuration

Figure 6 shows the xDSL access configuration. Figure 7 shows the Ethernet access configuration.

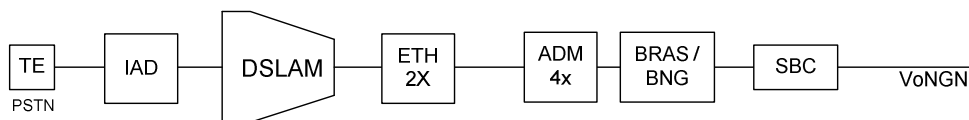

Figure 6: Reference configuration for DSL access

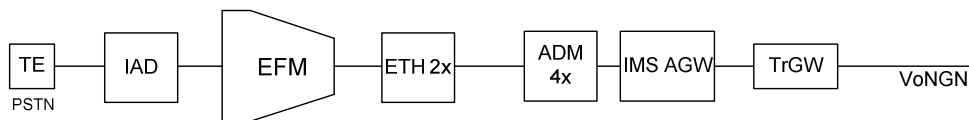

Figure 7: Reference configuration for Ethernet access

#### 4.2.1.5 GSM Access configuration

Figure 8 shows the GSM access configuration.

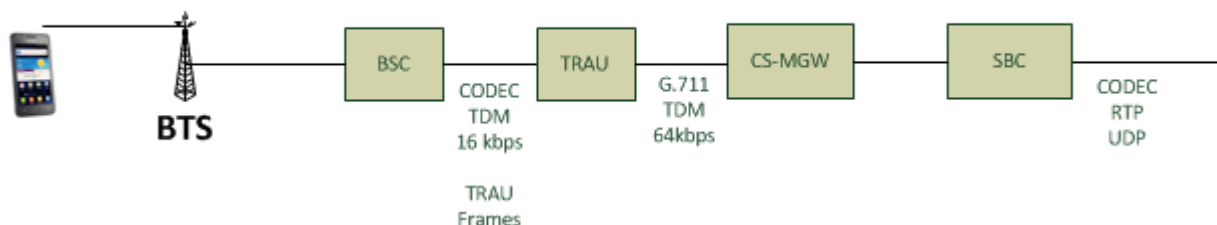

Figure 8: Reference configuration for GSM Access

#### 4.2.1.6 Access configuration from UMTS Release 4

Figure 9 shows the UMTS Release 4 access configuration.

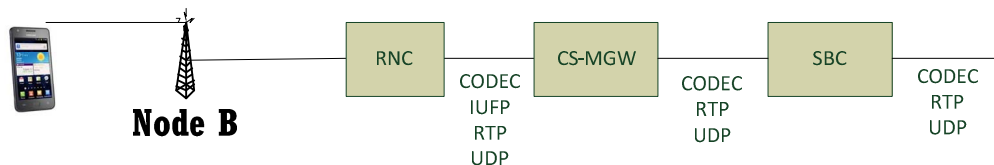

Figure 9: Reference configuration from UMTS Release 4

#### 4.2.1.7 Access configuration from LTE

Figure 10 shows the LTE access configuration. Figure 11 shows the IMS signalling and media plane entities.

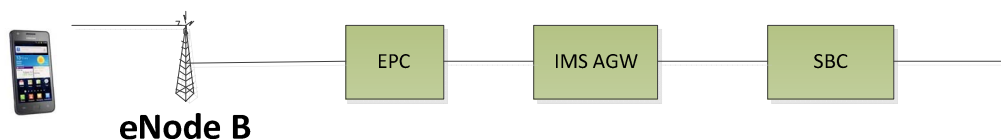

Figure 10: Reference configuration from LTE

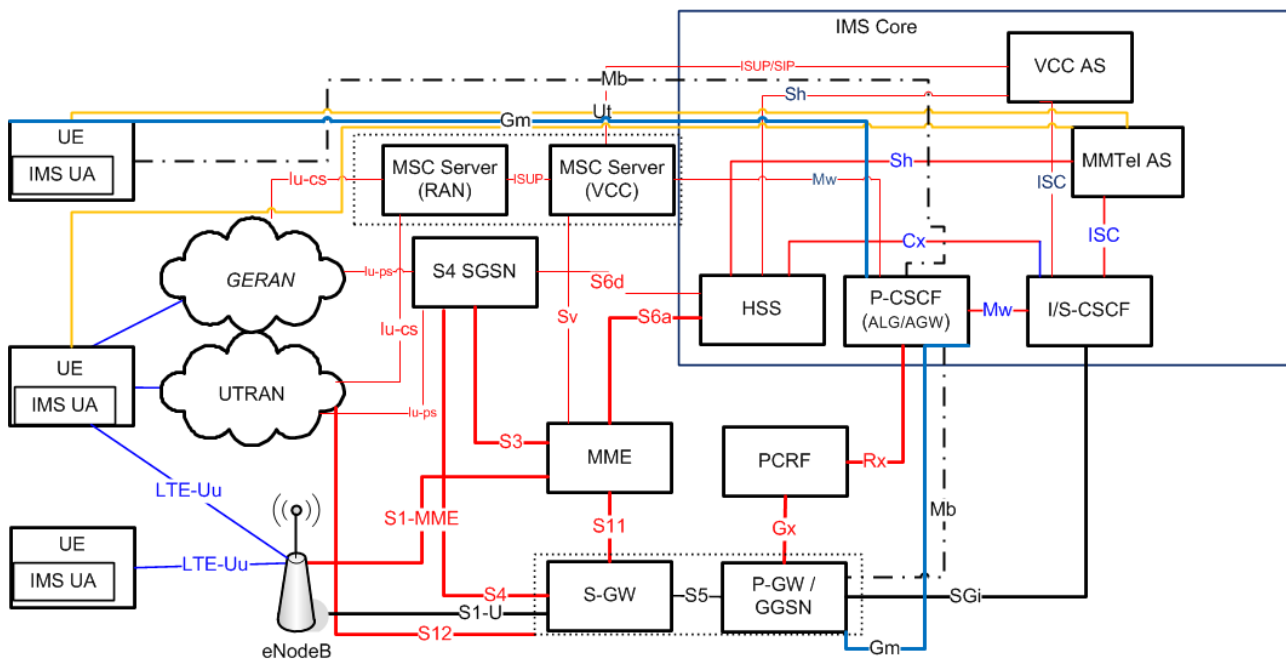

Figure 11: IMS, VoLTE, GSM and UMTS signalling and media plane entities

#### 4.2.1.8 CPE reference configuration

The Jitter and Delay calculation is based on the fact that different terminals are connected at same time on the CPE.

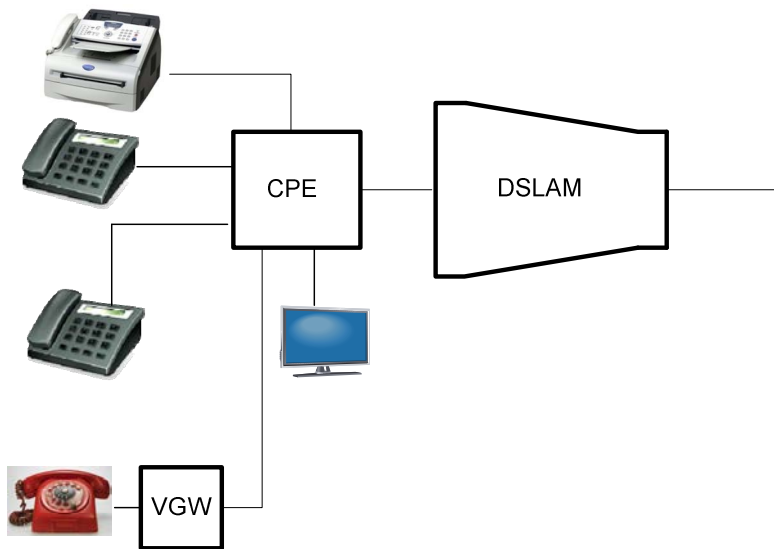

Figure 12: Terminal reference configuration for DSL access

### 4.3 Delay Values

The following clause 4.4 is based on the mathematical model described in TR 102 775 [i.20].

### 4.3.1 Backbone Delay

Table 1 shows the long distance delay values for typical reference distances.

**Table 1: Long Distance Delay**

<b>Distance</b>	<b>Delay (propagation and equipment delay)</b>
1 400 km	7 ms
5 000 km (Intra Regional)	25 ms
10 000 km (Inter Regional)	50 ms
20 000 km (Inter Regional)	100 ms
27 500 km (Inter Regional)	137 ms

Table 2 shows delay values between originating and terminating Service Provider premises. The End-to-End delay values are based on measured values in the public IP.

Table 2: End-to-End delay values between originating and terminating Service Provider premises

	West Europe Vienna	North Europe RU – Vladimir RU – Moscow SE- Östersund	East Europe RO – Bucharest HU – Budapest	South Europe GR– Athens IT - Roma	East Asia (CN- Dongguan)	South Asia Malaysia - MY	Oceania Australia -AU Sydney	N. America East Cost US Washington DC	N. America West Cost US Vancouver	Central America Panama - PA Mexico- MEX	South America Brasilia - BR	Africa ZA - Cap town Burkina Fasso
<b>West Europe</b> Bern Paris Frankfurt	DE - AT (Frankfurt – Vienna) 7 ms CH – DE (Bern – Frankfurt) 8 ms CH - AT (Bern – Vienna) 10 ms FR - AT (Paris - Vienna) 15 ms	CH - RU (Bern – Vladimir) 23 ms CH - RU (Bern – Moscow) 22 ms DE - RU (Frankfurt- Moscow) 21 ms DE - SE (Frankfurt – Östersund) 12 ms	CH - RO (Bern – Bucharest) 25 ms DE-RO (Frankfurt – Bucharest) 18 ms DE - HU (Frankfurt – Budapest) 12 ms	CH - GR (Bern – Athens) 30 ms DE - GR (Frankfurt – Athens) 24 ms IT - CH (Roma – Cern) 22 ms Frankfurt – Roma 13 ms	CH – CN (Bern - Dongguan) 150 ms DE - CN (Frankfurt – Dongguan) 160 ms	CH- MY 110 ms DE – MY 115 ms - 164 ms	CH - AU (Bern – Sydney) 170 ms DE - AU (Frankfurt – Melbourne) 165 ms DE - AU (Frankfurt – Sydney) 146 ms	CH - US (Bern – Washington) 46 ms DE - US (Frankfurt – Washington) 55 ms	CH - US (Bern – Vancouver) 75 ms DE - US (Frankfurt – Vancouver) 75 ms	CH - PA (Bern – Panama) 103 ms DE - MEX (Frankfurt – Mexico City) 75 ms	CH - BR (Bern – Sao Paulo) 136 ms DE - BR (Frankfurt – Sao Paulo) 125 ms	CH - ZA (Bern - Cape Town) 108 ms DE - ZA (Frankfurt – Cape Town) 90 ms BE-BF 90 ms – 130 ms
<b>North Europe</b> (SE - Östersund)		SE - RU (Östersund – Moscow) 10 ms	SE-RO (Östersund – Bucharest) 30 ms	SE - GR (Östersund - Athens) 42 ms	SE - CN 150 ms	SE - MY 124 ms	SE - AU 171 ms	SE - US 62 ms	SE-US 83 ms	SE - PA 84 ms SE - MEX 78 ms	SE - BR 155 ms	SE - ZA 87 ms
<b>East Europe</b> (HU - Budapest)		HU - RU (Budapest – Moscow) 33 ms	HU – RO (Budapest- Bucharest) 14 ms	HU – GR (Budapest – Athens) 20 ms	HU - CN 166 ms	HU - MY 125 ms	HU - AU 170 ms	HU - US 60 ms	HU-US 100 ms	HU - PA 95 ms HU - MEX 96 ms	HU - BR 152 ms	HU - ZA 100 ms
<b>South Europe</b> (IT - Roma)		IT - RU (Roma – Moscow) 38 ms	IT - RO (Roma – Bucharest) 32 ms	(IT - GR) Roma – Athens 23 ms	IT - CN 160 ms	IT - MY 150 ms	IT - AU 160 ms	IT - US 55 ms	IT-US 95 ms	IT – PA 104 ms IT - MEX 113 ms	IR - BR 108 ms	IT - ZA 95 ms

## 4.4 Network parameters: End-to-End Delay, Talker Echo Loudness Rating, R Value for VoIP

In this clause, end to end delay values (mouth to ear) for different access lines and the respective R-values (depending on the calculated delay) are shown.

The following clause 4.4.1 describes the Network parameters: End-to-End Delay, Talker Echo Loudness Rating for a national network. The delay calculation is based on one VoIP Channel with data and signalling traffic.

The delay calculation is based for the case when the access link is used for Voice and data application and the number of data packets in the playout Buffer are less than one.

If the same link is used for more voice channels, the number of channels which can be transmitted with a reasonable jitter over the link is between 70 % and 97 % of the channel capacity in dependency of the QoS policies.

For example: over a 2,048 Mbit/s link 9 voice channels (G.711, 20 ms packetization time) without QoS, 16 channels with diffserv and 21 channels with MPLS /VLAN can be transported.

Access links with a capacity of 128 kbit/s and 256 kbit/s should not be used for IP interconnections due to the high jitter caused on the access.

### 4.4.1 Delay with regional propagation delay (1 400 km / 7 ms)

The regional reference configuration is based on a distance of 1 400 km which is the average value for intra - European regional calls.

For the calculation of the Voice Quality parameters the used network parameters are contained in TR 102 775 [i.20], clause A.4. For the calculation were used the Packet sizes 10 ms and 20 ms, the codecs are G.729A [i.17] and G.711 [i.16].

In case of VBD, the goal is to keep the audio end-to-end delay constant during the entire call. The jitter buffer has to be implemented in such a way that any jitter occurring during the entire call will not change the end to end delay.

In case of voice, the aim of jitter buffer implementation is to keep the end to end audio delay as low as possible under all jitter conditions. Any jitter buffer implementation should minimize impairment of the listening speech quality as perceived by the user.

Tables 3a, 3b, 3c and 3d show End-to-End delay in ms and R value between DSL lines and POTS. The R values are based on wired terminals with the Talker Echo Loudness Rating TELR = 65. In the case of DSL to DSL connections are calculated between systems with the following upstream (e.g. 256, 384, 512, 768, 1 024 and 2 048) and downstream (e.g. 256, 384, 512, 768, 1 024, 1 152, 1 536, 2 048, 2 304, 3 072, 6 144).



**Table 3a: End-to-End delay between different access types  
with wired terminals, G.711 packet size 10 ms and with 7 ms propagation delay**

G.711/10												
Uplink / Downlink	256 kbit/s	384 kbit/s	512 kbit/s	768 kbit/s	1 024 kbit/s	1 152 kbit/s	1 536 kbit/s	2 048 kbit/s	2 304 kbit/s	3 072 kbit/s	6 144 kbit/s	POTS
POTS	-	-	-	-	-	-	-	-	-	-	-	35 ms R=92
512 kbit/s	-	-	85 ms R=91	80 ms R=91	78 ms R=91	77 ms R=91	75 ms R=91	74 ms R=91	74 ms R=91	73 ms R=91	72 ms R=91	55 ms R=91
768 kbit/s	-	-	-	75 ms R=91	73 ms R=91	72 ms R=91	70 ms R=91	69 ms R=91	69 ms R=91	68 ms R=91	68 ms R=91	53 ms R=91

**Table 3b: End-to-End delay between different access types,  
G.711, packet size 20 ms without TrFO and with 7 ms propagation delay**

G.711/20												
Uplink / Downlink	256 kbit/s	384 kbit/s	512 kbit/s	768 kbit/s	1 024 kbit/s	1 152 kbit/s	1 536 kbit/s	2 048 kbit/s	2 304 kbit/s	3 072 kbit/s	6 144 kbit/s	POTS
POTS	-	-	-	-	-	-	-	-	-	-	-	55 ms R=91
256 kbit/s	128 ms R=90	118 ms R=90	113 ms R=90	108 ms R=90	104 ms R=90	103 ms R=91	102 ms R=911	101 ms R=91	101 ms R=91	100 ms R=91	97 ms R=91	82 ms R=91
384 kbit/s	-	108 ms R=90	102 ms R=91	97 ms R=91	95 ms R=91	93 ms R=91	94 ms R=91	92 ms R=80	92 ms R=91	91 ms R=91	91 ms R=91	75 ms R=91

**Table 3c: End-to-End delay between different access types,  
G.711, packet size 20 ms without TrFO and with 7 ms propagation delay (continued)**

G.711/20												
Uplink / Downlink	256 kbit/s	384 kbit/s	512 kbit/s	768 kbit/s	1 024 kbit/s	1 152 kbit/s	1 536 kbit/s	2 048 kbit/s	2 304 kbit/s	3 072 kbit/s	6 144 kbit/s	POTS
512 kbit/s	-	-	97 ms R=91	92 ms R=91	91 ms R=91	91 ms R=91	91 ms R=91	91 ms R=91	90 ms R=91	90 ms R=91	90 ms R=91	74 ms R=91
768 kbit/s	-	-	-	91 ms R=91	90 ms R=91	90 ms R=91	90 ms R=91	89 ms R=91	89 ms R=91	89 ms R=91	89 ms R=91	73 ms R=91
1 024 kbit/s	-	-	-	-	90 ms R=91	89 ms R=91	89 ms R=91	89 ms R=91	89 ms R=91	88 ms R=91	88 ms R=91	73 ms R=91
2 048 kbit/s	-	-	-	-	-	-	-	88 ms R=91	88 ms R=91	88 ms R=91	88 ms R=91	72 ms R=91
GSM	189 ms R=82	183 ms R=83	181 ms R=82	180 ms R=83	180 ms R=83	179 ms R=83	179 ms R=83	179 ms R=83	179 ms R=83	179 ms R=83	179 ms R=83	163 ms R=84
UMTS Rel.4	187 ms R=82	181 ms R=83	179 ms R=83	178 ms R=83	178 ms R=83	177 ms R=83	177 ms R=83	177 ms R=83	177 ms R=83	176 ms R=83	176 ms R=83	161 ms R=84
LTE	150 ms R=90	144 ms R=90	142 ms R=90	142 ms R=90	141 ms R=90	141 ms R=90	140 ms R=90	140 ms R=90	140 ms R=90	140 ms R=90	139 ms R=90	124 ms R=90

Table 3d: End-to-End delay between different access types,  
G.729A, packet size 20 ms with 7 ms propagation delay

G.729/20												
Uplink / Downlink	256 kbit/s	384 kbit/s	512 kbit/s	768 kbit/s	1 024 kbit/s	1 152 kbit/s	1 536 kbit/s	2 048 kbit/s	2 304 kbit/s	3 072 kbit/s	6 144 kbit/s	POTS
POTS	-	-	-	-	-	-	-	-	-	-	-	-
256 kbit/s	125 ms R=80	117 ms R=80	112 ms R=80	108 ms R=81	105 ms R=81	105 ms R=81	102 ms R=81	102 ms R=81	102 ms R=81	101 ms R=81	100 ms R=81	83 ms R=81
384 kbit/s	-	108 ms R=81	103 ms R=81	99 ms R=81	97 ms R=81	96 ms R=81	94 ms R=81	94 ms R=81	94 ms R=81	94 ms R=81	94 ms R=81	79 ms R=81
512 kbit/s	-	-	94 ms R=81	94 ms R=81	94 ms R=81	94 ms R=81	94 ms R=81	94 ms R=81	94 ms R=81	94 ms R=81	94 ms R=81	78 ms R=81
768 kbit/s	-	-	-	94 ms R=81	94 ms R=81	94 ms R=81	93 ms R=81	93 ms R=81	93 ms R=81	93 ms R=81	93 ms R=81	78 ms R=81
1 024 kbit/s	-	-	-	-	93 ms R=81	93 ms R=81	93 ms R=81	93 ms R=81	93 ms R=81	93 ms R=81	93 ms R=81	77 ms R=81
2 048 kbit/s	-	-	-	-	-	-	-	93 ms R=81	93 ms R=81	93 ms R=81	93 ms R=81	77 ms R=81

## 4.4.2 Categories of User Satisfaction

The following information is an excerpt from Recommendation ITU-T G.109 [i.5].

While the single parameters describe the individual factors affecting speech transmission quality, it is the combined effect of all parameters together which leads to the overall level of speech transmission quality as perceived by the user. For transmission planning purposes, the E-model (G.107 [i.4]) is a useful tool for assessing the combined effect of all parameters and hence differentiating between categories of speech transmission quality.

The primary output of the E-model is the Transmission Rating Factor  $R$ . Table 4 gives the definitions of the categories of speech transmission quality in terms of ranges of Transmission Rating Factor  $R$  provided by Recommendation ITU-T G.107 [i.4]. Also provided are descriptions of "User satisfaction" for each category.

Table 4 shows Relation between  $R$ -value and user satisfaction.

**Table 4: Relation between  $R$ -value and user satisfaction**

R Value	MOS CQEN Value	Categories of User Satisfaction
95	4,44	Very satisfied (Best)
94	4,42	
93	4,40	
92	4,38	
91	4,36	
90	4,34	
89	4,31	Satisfied (High)
88	4,29	
87	4,26	
85	4,20	
82	4,09	
81	4,06	
80	4,02	Some users dissatisfied (Medium)
77	3,90	
73	3,73	
70	3,59	
68	3,50	Many users dissatisfied (Low)
60	3,10	
50	2,58	Nearly all users dissatisfied (Poor)
$MOS_{CQEN} = 1 + 0,035 \times R + 0,000007 \times R \times (R-60) \times (100-R)$		
NOTE 1: Connections with $R$ -values below 50 are not recommended.		
NOTE 2: Although the trend in transmission planning is to use $R$ -values, equations to convert $R$ -values into other metrics e.g. MOS, % GoB, % PoW.		

## 5 Guidance on Segment-connection Objectives

QoS objectives in Y.1541 are deemed to be applicable when access link speeds are at the T1 or E1 rate and higher. Today many network providers use technologies where they offer access link speeds much smaller than T1 or E1. De-jitter buffers in international MGW are often limited to a size of 100 ms, and it is recommended the total jitter not exceed 80 ms in order to leave some extra space for clock drift/skew.

The overall aim of the Segment-connection voice quality objectives is to enable network operators, service providers and indirectly also equipment manufacturers to provide end-to-end voice quality with which users are satisfied or even very satisfied. In order to achieve this goal the simplified approach here is, to limit end-to-end delay to 150 ms, except for cases where this is not feasible due to geographical constraints; Also the accumulated sum across the entire connection should not exceed  $I_e = 12$ . With routers and gateways currently deployed, the 150 ms margin can be reached with an inter-regional distance of 7 000 km (propagation delay of 60 ms) for xDSL Access. For PSTN Access an inter-regional distance of 15 000 km can be reached

TR 102 775 [i.20], annex A provides detailed information on parameters used in the present document which can be useful in the context of the present document.

## 5.1 Guidance on Access Segment Objectives

The following IPDV limits can be applied for access networks (between TE to included SBC).

**Table 5: Maximal IPDV values for xDSL and ETH Access Segment**

Nature of Network	Application	Jitter Value
Access Network (sending side)	Voice	< 35 ms
	Conversational video	< 5 ms
Access Network (receiving side)	Voice	10 ms (see note 1)
	Conversational video	< 5 ms
NOTE 1: 10 ms are recommended for Voice, the maximum IPDV value is 40 ms for Voice.		
NOTE 2: Conversational Video, minimal Service Rate 1 Mbps for 720p Video-Quality.		

**Table 6: Maximal IPDV values for MSAN**

Nature of Network	Jitter Value
Access Network (sending side)	< 5 ms
Access Network (receiving side)	< 5 ms

The target Jitter values are the maximum values occurring during one month. It is recommended to use dynamic Jitter Buffer with a minimum target delay in the Voice GW. Furthermore it is not recommended to use IP - IP GW (e.g. SBC) with Jitter Buffers.

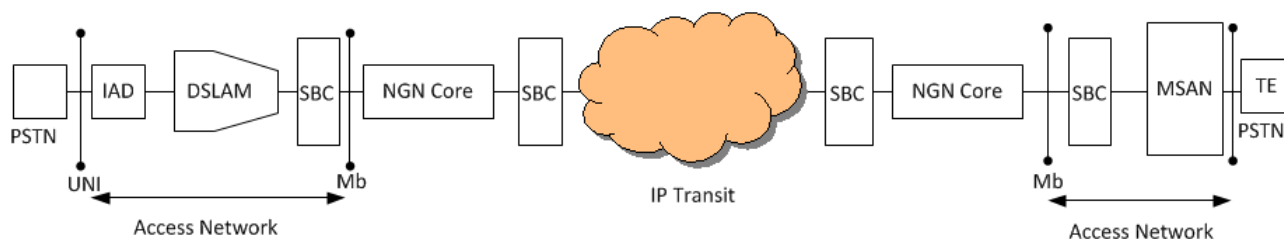

**Figure 13: IAD-MSAN Jitter Budget**

TE: Terminal Equipment, IAD: Integrated Access Device, DLSAM: Digital Subscriber Line Access Manager, SBC: Session Border Controller, MSAN/MGW: Media Gateway.

## 5.2 Guidance on Total Transit Segment Objectives

The following objectives can be applied between:

- Segment-connection point A  $\leftrightarrow$  Segment-connection point C.

See figure 1 for details. The objectives are based on the application of Class 0 of Recommendation ITU-T Y.1541 [i.2]. The determination of cases where Class 1 of Recommendation ITU-T Y.1541 [i.2] should be applied and the associated objectives are for further study.

**Table 7: Guidance on Objectives for IP Packet eXchange (IPX) Networks**

Nature of Network	Jitter Value
IPDV Intra-continent Jitter Value - <b>5 ms</b> per Provider (maximum of 2 involved in the service delivery chain) (see note)	10 ms
IPDV Inter-continent Jitter Value - <b>10 ms</b> per Provider (maximum of 2 involved in the service delivery chain) (see note)	20 ms
IPLR	$3,0 \times 10^{-4}$
IPER	$3 \times 10^{-5}$
le	0
NOTE: The Jitter Values are based on values contained in the GSMA document IR.3445 [i.11].	

The proposed transit delay value applies to total transit segments which are intra-continental, only. It is assumed that transcoding can be completely avoided in the total transit segment.

Transit delay includes the core and distribution delay as well as the propagation delay defined in Recommendation ITU-T Y.1541 [i.2].

As the Jitter Buffers in the international MGW are often limited to 100 ms, the total Jitter should not be higher than 80 ms (to leave some extra space for clock drift/skew). For being able to deliver higher quality voice connections, the total jitter should be significantly lower.

## 5.2.1 Availability

Values for availability are the following:

- Availability of the IP Backbone Service Provider Core: 99,995 %.
- Service Providers connection to IP Backbone Service Provider core with single connection: 99,7 %.
- Service Providers connection to IP Backbone Service Provider core with dual connection: 99,9 %.

## 5.3 Voice Terminals

In order to be able to achieve the goal of users being satisfied or even very satisfied with the overall voice communication quality it is assumed that the VoIP terminals used in this context comply with one or more of the following ETSI standards:

- ES 202 737 [i.6].
- ES 202 738 [i.7].
- ES 202 739 [i.8].
- ES 202 740 [i.9] (End-to-End Aspects).

---

# 6 End-to-End Aspects

Figure 14 presents the delay distribution between the calling and the called user. The delay of the calling user contains the packetization delay, the compression delay, the serialization time and the play out buffer size. The delay of the called user contains the decompression, the serialization time, the dejitterbuffer delay and the PLC. The reference connection is based on an inter-regional distance of 7 000 km (propagation delay and core equipment delay - 60 ms), Inter-continent Jitter Value 20 ms, minimal bandwidth 384 kbit/s (uplink and downlink).

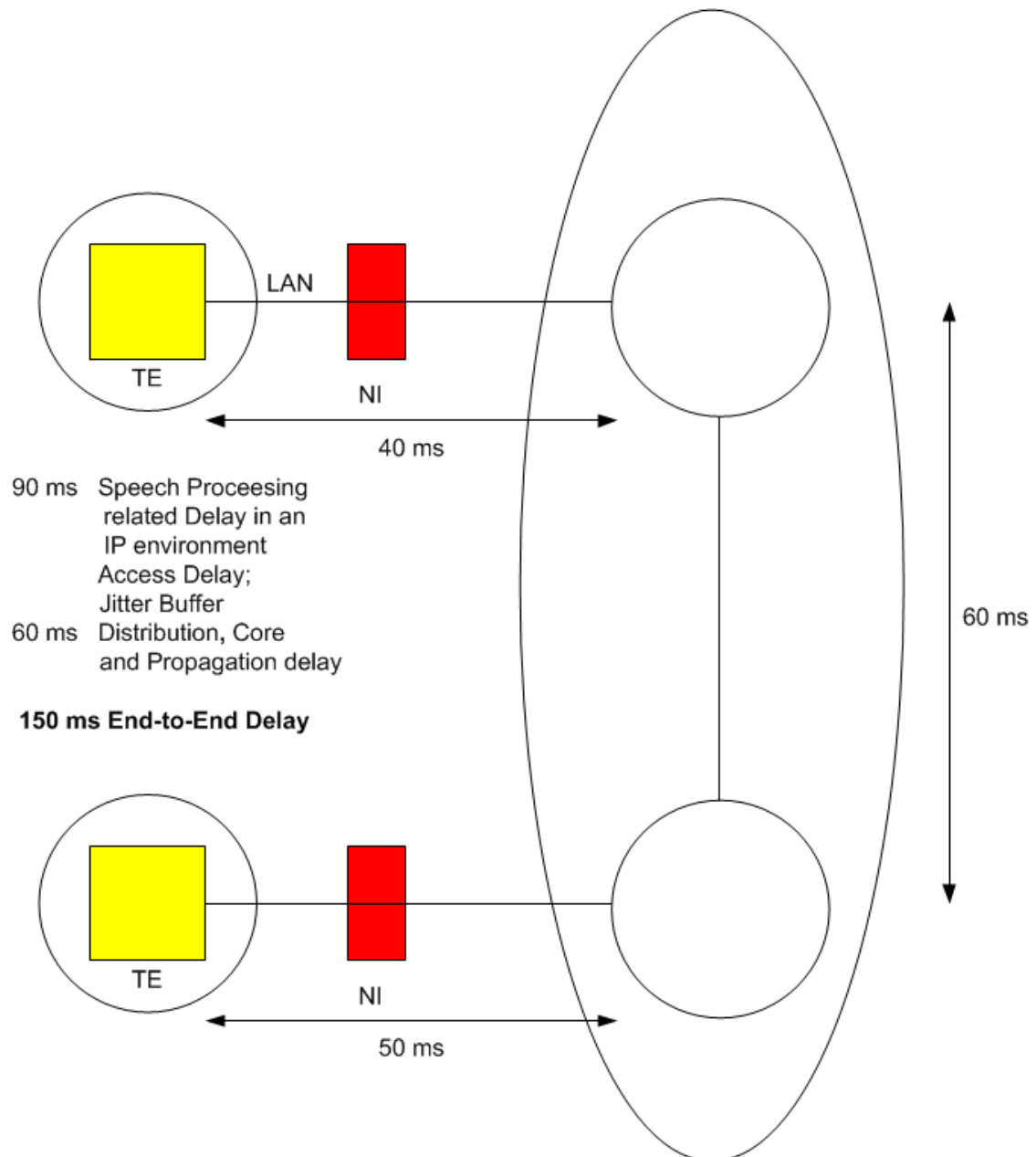

**Figure 14: Maximal delay values for BEST (G.109) voice communication quality and Network Access Jitter < 35 ms**

## 7 Transport of UDI

The IP-based network should also be capable to carry the 64 kbit/s transparent data service described in Recommendation ITU-T I.231.1 [i.18], also known as "64 k clear-mode". The considerations of the objective here are based on the Recommendation ITU-T G.826 [i.19], a standard for synchronous digital networks. While the IP core is a packet network and not a synchronous network, it is being used to emulate a service currently transported over a synchronous network. Hence the performance of the emulation should be better than the performance of the synchronous network as specified by Recommendation ITU-T G.826 [i.19]. The standard requires an Errored Second Ratio (ESR) of  $< 0,16$  for an STM-1 link which can carry about 1 200 "clear-mode" channels. From this, the end-to-end probability of loss per packet can be shown to be about  $1,5 \times 10^{-6}$ . In Recommendation ITU-T G.826 [i.19], budgets of 18,5 % of  $1,5 \times 10^{-6}$  were allocated to each national network, so the packet loss for a national connection should be no more than  $2,75 \times 10^{-7}$ . Allocation of this ratio to individual operators' networks within the national network is yet to be agreed, but it is fairly unlikely that there will be more than three operators' switched networks between any customer and the international gateway, so an initial allocation could be  $9,0 \times 10^{-8}$  to each operator's network.

**Table 8: Summary of provisional objectives**

Parameter	Provisional Objective
IP packet loss ratio for national connections	$2,75 \times 10^{-7}$
IP packet loss ratio for each operator's network	$9,0 \times 10^{-8}$
End-to-end probability IP packet loss ratio	$1,5 \times 10^{-6}$
IP packet error ratio for each operator's network	$1,0 \times 10^{-8}$
Managed DSL access, minimum Access Rate up [G.1050]	2 Mbit/s
Managed DSL access, minimum Access Rate down [G.1050]	22 Mbit/s
Partially managed DSL access, minimum Access Rate up [G.1050]	3 Mbit/s
Partially managed DSL access, minimum Access Rate down [G.1050]	24 Mbit/s

## 8 Synchronization of endpoints

To ensure the synchronization of the endpoints (e.g. MSAN, GW; AGW), they should be synchronized with Synchronous Ethernet (SyncE) based on the Recommendations ITU-T G.8261 [i.12], G.8262 [i.13] and G.8264 [i.14]. Additionally, PTP (IEEE 1588 v2 [i.15]) and NTPv4 may be used as mean for synchronization of endpoints. A distinction needs to be made between time and timing synchronization. For legacy networks normally only timing synch is important, whereas in IP based NGN both time and timing can be important. Synchronous Ethernet provides timing synch whereas PTP and NTP provide both if correctly implemented.

For the transport of VBD and for the ISDN Emulation the accuracy necessary in the CPEs and GWs is a free-run accuracy of  $\pm 4,6$  ppm and a holdover stability of 10-10/day according to Recommendation ITU-T G.813 [i.21].

Figure 15 illustrates the Synchronous Distribution of a Packet Network using SyncE.



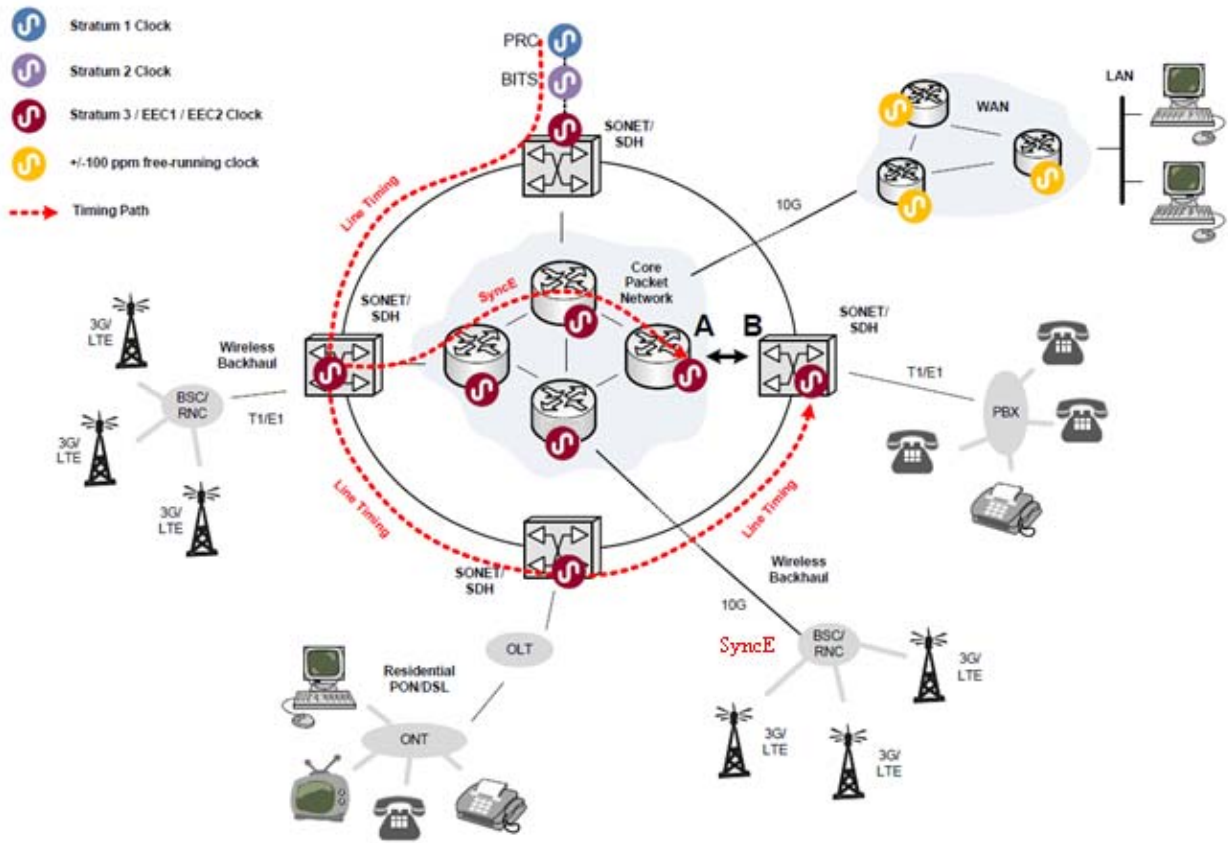

Figure 15: Synchronization Distribution of a Packet Network Using SyncE

---

## History

<b>Document history</b>		
V1.1.1	May 2014	Publication
V1.1.2	May 2014	Publication