

ETSI TS 102 826 V1.2.1 (2009-11)

Technical Specification

Digital Video Broadcasting (DVB); DVB-IPTV Profiles for TS 102 034



Reference

RTS/JTC-DVB-268

Keywords

broadcast, digital, DVB, IP, profile, TV, video

ETSI

650 Route des Lucioles
F-06921 Sophia Antipolis Cedex - FRANCE

Tel.: +33 4 92 94 42 00 Fax: +33 4 93 65 47 16

Siret N° 348 623 562 00017 - NAF 742 C
Association à but non lucratif enregistrée à la
Sous-Préfecture de Grasse (06) N° 7803/88

Important notice

Individual copies of the present document can be downloaded from:

<http://www.etsi.org>

The present document may be made available in more than one electronic version or in print. In any case of existing or perceived difference in contents between such versions, the reference version is the Portable Document Format (PDF). In case of dispute, the reference shall be the printing on ETSI printers of the PDF version kept on a specific network drive within ETSI Secretariat.

Users of the present document should be aware that the document may be subject to revision or change of status. Information on the current status of this and other ETSI documents is available at

<http://portal.etsi.org/tb/status/status.asp>

If you find errors in the present document, please send your comment to one of the following services:

http://portal.etsi.org/chaicor/ETSI_support.asp

Copyright Notification

No part may be reproduced except as authorized by written permission.
The copyright and the foregoing restriction extend to reproduction in all media.

© European Telecommunications Standards Institute 2009.
© European Broadcasting Union 2009.
All rights reserved.

DECT[™], **PLUGTESTS**[™], **UMTS**[™], **TIPHON**[™], the TIPHON logo and the ETSI logo are Trade Marks of ETSI registered for the benefit of its Members.

3GPP[™] is a Trade Mark of ETSI registered for the benefit of its Members and of the 3GPP Organizational Partners.

LTE[™] is a Trade Mark of ETSI currently being registered for the benefit of its Members and of the 3GPP Organizational Partners.

GSM[®] and the GSM logo are Trade Marks registered and owned by the GSM Association.

Contents

Intellectual Property Rights	4
Foreword.....	4
1 Scope	5
2 References	5
2.1 Normative references	5
2.2 Informative references.....	6
3 Definitions and abbreviations.....	6
3.1 Definitions	6
3.2 Abbreviations	6
4 Overview	7
4.1 Rationale.....	7
4.2 Concept	7
4.3 Service and Device Impacts	8
5 DVB-IPTV Handbook Modules.....	8
5.1 Foundation Layer/Provisioning Module.....	8
5.2 Media Transport Module.....	8
5.3 Connection Module	9
5.4 Media Format Module.....	9
5.5 Service Discovery Module	9
5.6 Metadata Module.....	10
5.7 Reliable Transport Module.....	11
6 Profiles	11
6.1 Basic.....	11
6.2 Live Media Broadcast (LMB)	11
6.3 Content On Demand (CoD).....	12
6.4 Content Download (CDS)	12
7 Extensions	12
8 Profile Summary	13
History	14

Intellectual Property Rights

IPRs essential or potentially essential to the present document may have been declared to ETSI. The information pertaining to these essential IPRs, if any, is publicly available for **ETSI members and non-members**, and can be found in ETSI SR 000 314: "*Intellectual Property Rights (IPRs); Essential, or potentially Essential, IPRs notified to ETSI in respect of ETSI standards*", which is available from the ETSI Secretariat. Latest updates are available on the ETSI Web server (<http://webapp.etsi.org/IPR/home.asp>).

Pursuant to the ETSI IPR Policy, no investigation, including IPR searches, has been carried out by ETSI. No guarantee can be given as to the existence of other IPRs not referenced in ETSI SR 000 314 (or the updates on the ETSI Web server) which are, or may be, or may become, essential to the present document.

Foreword

This Technical Specification (TS) has been produced by Joint Technical Committee (JTC) Broadcast of the European Broadcasting Union (EBU), Comité Européen de Normalisation ELECTrotechnique (CENELEC) and the European Telecommunications Standards Institute (ETSI).

NOTE: The EBU/ETSI JTC Broadcast was established in 1990 to co-ordinate the drafting of standards in the specific field of broadcasting and related fields. Since 1995 the JTC Broadcast became a tripartite body by including in the Memorandum of Understanding also CENELEC, which is responsible for the standardization of radio and television receivers. The EBU is a professional association of broadcasting organizations whose work includes the co-ordination of its members' activities in the technical, legal, programme-making and programme-exchange domains. The EBU has active members in about 60 countries in the European broadcasting area; its headquarters is in Geneva.

European Broadcasting Union
CH-1218 GRAND SACONNEX (Geneva)
Switzerland
Tel: +41 22 717 21 11
Fax: +41 22 717 24 81

Founded in September 1993, the DVB Project is a market-led consortium of public and private sector organizations in the television industry. Its aim is to establish the framework for the introduction of MPEG-2 based digital television services. Now comprising over 200 organizations from more than 25 countries around the world, DVB fosters market-led systems, which meet the real needs, and economic circumstances, of the consumer electronics and the broadcast industry.

1 Scope

DVB has produced a specification for the delivery of MPEG-2 TS based DVB services over IP networks, referred to as the DVB-IPTV handbook [1]. The DVB-IPTV handbook covers several types of IPTV services (e.g. Live Media Broadcast, Content on Demand, Content Download). It has become evident that every building block in the DVB-IPTV handbook is not necessarily required for the deployment of specific IPTV systems. It is however currently not possible to implement a subset of the building blocks and claim compliancy to the DVB-IPTV handbook.

In order to facilitate and maximize the stepwise deployment of IPTV services, the present document defines a small set of service oriented profiles. A profile is a coherent subset of the DVB-IPTV handbook, allowing companies to claim a degree of DVB compliancy for IPTV services.

For details about specific technologies referenced in the present document, we invite the reader to refer to the DVB-IPTV handbook [1].

2 References

References are either specific (identified by date of publication and/or edition number or version number) or non-specific.

- For a specific reference, subsequent revisions do not apply.
- Non-specific reference may be made only to a complete document or a part thereof and only in the following cases:
 - if it is accepted that it will be possible to use all future changes of the referenced document for the purposes of the referring document;
 - for informative references.

Referenced documents which are not found to be publicly available in the expected location might be found at <http://docbox.etsi.org/Reference>.

NOTE: While any hyperlinks included in this clause were valid at the time of publication ETSI cannot guarantee their long term validity.

2.1 Normative references

The following referenced documents are indispensable for the application of the present document. For dated references, only the edition cited applies. For non-specific references, the latest edition of the referenced document (including any amendments) applies.

- [1] ETSI TS 102 034 (V1.4.1): "Digital Video Broadcasting (DVB); Transport of MPEG-2 TS Based DVB Services over IP Based Networks".
- [2] ETSI TS 102 539 (V1.2.1): "Digital Video Broadcasting (DVB); Carriage of Broadband Content Guide (BCG) information over Internet Protocol (IP)".
- [3] ETSI TS 101 154 (V1.8.1): "Digital Video Broadcasting (DVB); Specification for the use of Video and Audio Coding in Broadcasting Applications based on the MPEG-2 Transport Stream".
- [4] IETF RFC 3376: "Internet Group Management Protocol, Version 3".
- [5] IETF RFC 3550: "RTP: A Transport Protocol for Real-Time Applications".

2.2 Informative references

The following referenced documents are not essential to the use of the present document but they assist the user with regard to a particular subject area. For non-specific references, the latest version of the referenced document (including any amendments) applies.

Not applicable.

3 Definitions and abbreviations

3.1 Definitions

For the purposes of the present document, the following terms and definitions apply:

extension: non-required option that can be added to a profile in order to enhance it

module: set of options (protocol and media format) for fulfilling a given functionality of the DVB-IPTV handbook

option: one technical possibility for providing the functionality of a module

profile: collection of functionalities making use of a set of options taken from the modules, that defines a point of interoperability for DVB-IPTV ecosystems

3.2 Abbreviations

For the purposes of the present document, the following abbreviations apply:

BCG	Broadband Content Guide
CDS	Content Download Service
CoD	Content on Demand
DHCP	Dynamic Host Configuration Protocol
DVBSTP	DVB SD&S Transport Protocol
EIT	Event Information Table
HNEED	Home Network End Device
HTTP	Hyper Text Transport Protocol
IGMP	Internet Group Management Protocol
IP	Internet Protocol
IPI	IP Infrastructure
LMB	Live Media Broadcast
MPEG	Moving Pictures Expert Group
MPEG-2 TS	MPEG-2 Transport Stream
PSI	Program Specific Information
RTP	Real-time Transport Protocol
RTSP	Real Time Streaming Protocol
SD&S	Service Discovery and Selection
SDT	Service Description Table
SDTV	Standard Definition TV
SI	Service Information
SOAP	Simple Object Access Protocol
TVA	TV-Anytime
UDP	User Datagram Protocol
XML	eXtensible Markup Language

4 Overview

4.1 Rationale

The DVB-IPTV handbook specifies the protocols and mechanisms that shall be supported on the interface to the HNED defined as IPI-1 in TS 102 034 [1], clause 4 and covers several types of IPTV services (e.g. Live Media Broadcast, CoD, Content Download). In order to be compliant, an HNED will need to support all the mandatory technologies specified in the DVB-IPTV handbook as subsets are not defined. But some operators want to be able to deploy only one type of IPTV services at a time (e.g. only Live Media Broadcast, or only Content Download for far end customers with limited bandwidth), or to mix a DVB compliant IPTV service with a proprietary IPTV service (e.g. a DVB compliant Live Media Broadcast, and a proprietary Content on Demand portal).

Hence the present document defines profiles to help operators and manufacturers claim DVB-IPTV compliancy to a useful and well-defined subset of the DVB-IPTV handbook. This is necessary for lower-cost and differentiated services that do not require full implementation of all features of the DVB-IPTV handbook.

4.2 Concept

The present document uses the following terminology:

profile: a collection of functionalities making use of a set of options taken from the modules, that defines a point of interoperability for DVB-IPTV ecosystems. Profiles may additionally include extensions, which may enhance or complement functionalities.

module: a set of options (protocol and media format) for fulfilling a given functionality of the DVB-IPTV handbook. These options may be unrelated, may be combined or may be incompatible.

option: one technical possibility for providing the functionality of a module.

extension: a non-required option that can be added to a profile to enhance it. It can either be another option from a module already specified in the profile, or an option from a new module.

For example, the Media Transport module contains the transport mechanisms defined in the DVB-IPTV handbook to carry IPTV content. The module includes two options, direct UDP and RTP/UDP protocols.

The DVB-IPTV handbook can then be seen as a toolbox, integrating a set of modules. Each module offers one or more technical options to achieve a specific functionality. Those options can be used to define a profile.

The aim is to have profiles with only mandatory options and possible extensions. Figure 1 presents a general view of the profile, module, option and extension relationship.

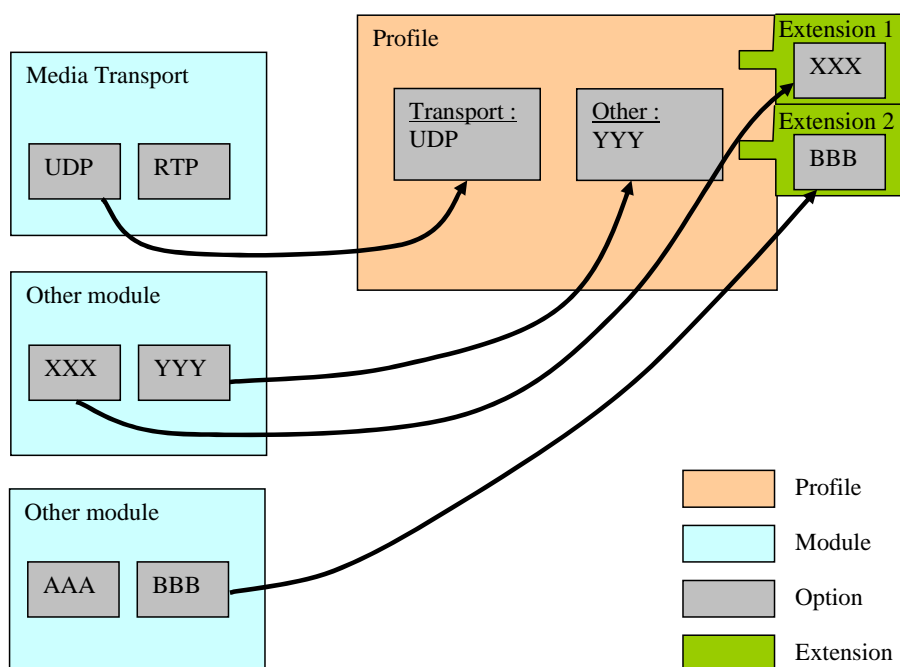

Figure 1: Relationship between Profile, Module, Option and Extension

4.3 Service and Device Impacts

The DVB-IPTV handbook defines the protocols and data structures that are used "on the wire", i.e. between servers and clients and that shall be supported on the interface to the HNED (IPI-1). So when different technologies are available in the handbook to perform a specific functionality, the HNED will need to implement all of them to be compliant, but a DVB-IPTV service may only implement one.

For example, the Media Transport module contains both UDP and RTP/UDP technologies. It means that it is perfectly possible for an operator to define a UDP only DVB-IPTV service, while the HNED shall implement both UDP and RTP transport layers to be able to manage both types of transport.

The same philosophy applies for DVB-IPTV profiles, i.e. when several options are possible for a single module within a profile, it means that the HNED shall implement all of them but a DVB-IPTV service compliant to this profile can implement only a subset of them.

5 DVB-IPTV Handbook Modules

5.1 Foundation Layer/Provisioning Module

This module provides all IP connectivity (i.e. addressing, routing; etc.) needed for the HNED to communicate with its IP environment and to connect to a service provider. It regroups:

- DHCP (address assignment and device configuration).
- IP address autoconfiguration.

NOTE: This module is mandatory in every profile.

5.2 Media Transport Module

Two transport technologies can be used to deliver streamed IPTV services (LMB and CoD):

- UDP only ([1], clause 7.1.2);

- RTP/UDP ([1], clause 7.1.1).

NOTE: The RTP layer as defined within the DVB-IPTV handbook does not require all the features described in the RTP RFC [5]. Several fields are not mandatory, and more importantly it is required that Receiver Reports are not generated (see TS 102 034 [1], clause 7.1.1.1) unless the Retransmission extension is supported by the HNED and the DVB Retransmission service is provisioned.

Two transport technologies can be used to download content items:

- HTTP/TCP ([1], clause 10.6.3);
- FLUTE/UDP ([1], clause 10.6.2).

5.3 Connection Module

The DVB-IPTV handbook specifies connection protocols depending on the type of IPTV services:

- For a Live Media Broadcast Service (delivered over multicast), IGMP is required ([1] clause 7.3.1); additionally RTSP may be used ([1] clause 6.5).
- For a Live Media Broadcast with Trick Modes or Content on Demand Service (delivered over unicast), RTSP is required ([1] clause 7.3.2).
- For Content Download Services, HTTP to connect to unicast download, ([1] clause 10.6.3) and IGMP to connect to multicast download, are required ([1] clause 10.6.2).

NOTE: The DVB-IPTV handbook specifies the use of IGMP version 3 [4]. It means that the HNED is required to implement IGMPv3. In conformance with the IGMP RFC backward compatibility rules, it is perfectly possible to plug a v3 HNED on a v1 or v2 network. In this case, the IGMPv3 stack of the HNED will deduce the IGMP version used by the devices of the network it is attached to by analyzing the IGMP Query messages it receives. Refer to the IGMPv3 RFC [4], clause 7 for more details.

5.4 Media Format Module

The DVB-IPTV handbook references TS 101 154 [3] for audio and video coding formats based on MPEG-2 Transport Stream content delivery.

TS 101 154 [3] proposes a set of coding formats for audio and video. For example, video can be MPEG2, H264 SD, H264 HD, VC-1 SD, etc.

The profiles defined in the present document will not specify which coding formats shall be used. DVB considers that it is an application decision made by manufacturers, content and service providers and broadcasters.

The deployed service compliant to a profile is required to use at least one coding format from TS 101 154 [3].

For Content Download Services, several content item formats and file formats may be used to represent audio-visual information (see TS 102 034 [1], clause 10.4).

5.5 Service Discovery Module

SD&S is the mandatory service discovery solution of the DVB-IPTV handbook. There are two ways to receive SD&S data:

- Pull mode with HTTP ([1], clause 5.4.2).
- Push mode with DVBSTP ([1], clause 5.4.1).

Both modes must be supported by an HNED to discover DVB-IPTV services.

The Broadband Content Guide [2] specifies the signaling and delivery of TV-Anytime information in DVB-IPTV services. The BCG addresses Content on Demand, Live Media Broadcast and Content Download, whether the content is available as a DVB-IPTV service or as a DVB broadcast service. There are three ways to access BCG metadata:

- Pull mode with HTTP ([6], clause 4.1.2.2.1).
- Push mode with DVBSTP ([2], clause 4.1.2.2.2).
- Query mode using HTTP/SOAP ([7], clause 4.2).

The first two options are mandatory. The third one is optional, as defined in TS 102 539 [2].

There are three transport mechanisms to receive CDS download session descriptions:

- Unicast delivery with HTTP for download session descriptions represented in XML and SDP ([1], clause 10.5.5.2 and 10.5.5.4, respectively)
- Multicast delivery for download session descriptions represented in for XML using DVBSTP ([1], clause 10.5.5.1)
- Multicast delivery for download session descriptions represented in for SDP using SAP ([1], clause 10.5.5.3)

Only the unicast delivery with HTTP for XML-based download session descriptions and the multicast delivery for XML-based download session descriptions with DVBSTP are required.

5.6 Metadata Module

The DVB-IPTV handbook relies on three options to define a complete set of DVB-IPTV metadata:

- The SI/PSI tables of the MPEG-2 TS stream.
- The SD&S XML data structure for service related metadata.
- TV-A elements for content related metadata delivered via the Broadband Content Guide, called BCG-TVA hereafter.

Furthermore, there are two possibilities for a DVB-IPTV service to populate the SD&S XML data structure (see TS 102 034 [1], clause 5.2.6.2):

- TS-Full SI: this means that all necessary metadata are carried within the SI/PSI tables (EIT, SDT, etc.) embedded in the TS. The SD&S XML data is minimal.
- TS-Optional SI: this means that only MPEG PSI (PAT and PMT tables) are required to be embedded in the TS, all other MPEG-2 and DVB tables are optional and all metadata are carried within the SD&S XML data structures.

NOTE: The SD&S XML TS-Optional SI data structure is a superset of the SD&S XML TS-Full SI data structure. In the rest of the document, we will refer to "SD&S XML data", meaning that both TS-Full SI and TS-Optional SI data structures are included in this wording.

The mandatory service discovery part of the DVB-IPTV handbook for content download services defines the CDS download session description. There are two options to describe the CDS download session:

- XML ([1], clause C.2).
- SDP ([1], clause G.2).

Only XML is required to discover CDS download sessions.

5.7 Reliable Transport Module

For LMB and CoD services, the DVB-IPTV handbook defines two options for packet loss repair, enabling reliable transport for streamed IPTV services:

- Application Layer Forward Error Correction (AL-FEC), ([1], annex E).
- Retransmission (RET), ([1], annex F).

Either option can be used in combination with CoD/LMB service.

NOTE 1: Combination of AL-FEC and RET can be used, see [1], clause F.10.

NOTE 2: These reliability options can only be used when the CoD/LMB service is transported over RTP/UDP.

For content download services, the DVB-IPTV handbook includes the option to provide more reliable multicast delivery based on FLUTE/UDP transport with Raptor FEC ([1], clause 10.6.2.2.2).

6 Profiles

This clause defines four profiles for DVB-IPTV systems. Each profile lists the required modules and the required options within each module.

NOTE: The foundation layer/provisioning module is required in each profile and is not listed under each profile to ease readability.

6.1 Basic

This profile is defined to accommodate existing IPTV deployments. It can therefore be seen as a first step for an operator to achieve a basic degree of DVB-IPTV compliance with its existing network and HNEDs.

The following options shall be supported:

- transport: UDP;
- connection: IGMP;
- format: MPEG-2 coding formats. TS 101 154 [3] clauses are:
 - video: 5.1: 25 Hz MPEG-2 SDTV;
 - video: 5.3: 30 Hz MPEG-2 SDTV;
 - audio: 6.1: MPEG-1 and MPEG-2 backward compatible audio.
- discovery: SD&S;
- metadata: SI/PSI tables in the MPEG2-TS stream and SD&S XML data.

6.2 Live Media Broadcast (LMB)

This profile defines the required subset to build live IPTV services.

The following options shall be supported:

- transport: UDP and RTP/UDP;
- connection: IGMP;
- format: Refer to TS 101 154 [3];

- discovery: SD&S;
- metadata: SI/PSI tables in the MPEG2-TS stream and SD&S XML data.

6.3 Content On Demand (CoD)

This profile defines the required subset to build On-Demand IPTV services.

The following options shall be supported:

- transport: UDP and RTP/UDP;
- connection: RTSP;
- format: Refer to TS 101 154 [3];
- discovery: SD&S and BCG;
- metadata: SD&S XML data and BCG-TVA.

6.4 Content Download (CDS)

This profile defines the required subset to build IPTV Content Download Services.

The following options shall be supported:

- Transport: HTTP/TCP and FLUTE/UDP
- Connection: HTTP and IGMP
- Format:
 - Audio/Video: Refer to TS 101 154 [3] document.
 - Content-Item-Format: 0, 1, and 2.
 - File-Format: MPEG-2 transport stream format.
- Discovery: SD&S and BCG.
- Metadata: SD&S XML, BCG-TVA and XML-coded CDS download session description.

7 Extensions

Extensions can be defined as enhancement to profiles. This clause presents a non exhaustive list of possible extensions:

Reliable transport

- The addition of the Hybrid AL-FEC system, as defined in the DVB-IPTV handbook, enables a more reliable streaming technology.
 - Targeted Profiles: LMB, CoD.
- The addition of the Retransmission system, as defined in the DVB-IPTV handbook, enables a more reliable streaming technology.
 - Targeted Profiles: LMB, CoD.
- The addition of Raptor FEC for object delivery, as defined in the DVB-IPTV handbook, provides a more reliable CDS multicast download technology.
 - Targeted Profile: CDS.

Advanced metadata

- The addition of BCG tool and TVA metadata enables the use of advanced Electronic Program Guide (EPG).
 - Targeted Profiles: Basic, LMB.

Advanced connection control

- The RTSP protocol can be added to provide an additional session management layer.
 - Targeted Profiles: Basic, LMB.

8 Profile Summary

Table 1 summarizes the four defined profiles. Please refer to the relevant profile clause for more details. For each of those profiles, the foundation/provisioning module (not shown) is required and extensions can be used, as presented in clause 7.

Table 1

Profiles	Modules				
	Transport	Connection	Format	Discovery	Metadata
Basic	UDP	IGMP	MPEG2	SD&S	SD&S XML data SI/PSI tables
LMB	UDP RTP/UDP	IGMP	Refer to TS 101 154 [3]	SD&S	SD&S XML data SI/PSI tables
CoD	UDP RTP/UDP	RTSP	Refer to TS 101 154 [3]	SD&S BCG	SD&S XML data BCG-TVA
CDS	HTTP FLUTE	HTTP IGMP	Refer to TS 101 154 [3] and to TS 102 034 [1], clause 10.4	SD&S BCG	SD&S XML data BCG-TVA XML-coded CDS Download Session Description

History

Document history		
V1.1.1	July 2008	Publication
V1.2.1	November 2009	Publication