

# ETSI TS 102 551-1 V1.1.1 (2006-12)

---

*Technical Specification*

## **Satellite Earth Stations and Systems (SES); Satellite Digital Radio (SDR) Systems; Inner Physical Layer of the Radio Interface; Part 1: Single carrier transmission**

---



---

Reference

DTS/SES-00285-1

---

Keywords

digital, layer 1, radio, satellite

**ETSI**

650 Route des Lucioles  
F-06921 Sophia Antipolis Cedex - FRANCE

Tel.: +33 4 92 94 42 00 Fax: +33 4 93 65 47 16

Siret N° 348 623 562 00017 - NAF 742 C  
Association à but non lucratif enregistrée à la  
Sous-Préfecture de Grasse (06) N° 7803/88

---

**Important notice**

Individual copies of the present document can be downloaded from:

<http://www.etsi.org>

The present document may be made available in more than one electronic version or in print. In any case of existing or perceived difference in contents between such versions, the reference version is the Portable Document Format (PDF). In case of dispute, the reference shall be the printing on ETSI printers of the PDF version kept on a specific network drive within ETSI Secretariat.

Users of the present document should be aware that the document may be subject to revision or change of status. Information on the current status of this and other ETSI documents is available at

<http://portal.etsi.org/tb/status/status.asp>

If you find errors in the present document, please send your comment to one of the following services:

[http://portal.etsi.org/chaicor/ETSI\\_support.asp](http://portal.etsi.org/chaicor/ETSI_support.asp)

---

**Copyright Notification**

No part may be reproduced except as authorized by written permission.  
The copyright and the foregoing restriction extend to reproduction in all media.

© European Telecommunications Standards Institute 2006.  
All rights reserved.

**DECT**<sup>TM</sup>, **PLUGTESTS**<sup>TM</sup> and **UMTS**<sup>TM</sup> are Trade Marks of ETSI registered for the benefit of its Members.  
**TIPHON**<sup>TM</sup> and the **TIPHON logo** are Trade Marks currently being registered by ETSI for the benefit of its Members.  
**3GPP**<sup>TM</sup> is a Trade Mark of ETSI registered for the benefit of its Members and of the 3GPP Organizational Partners.

# Contents

Intellectual Property Rights .....	4
Foreword.....	4
1 Scope .....	5
2 References .....	5
3 Definitions, symbols and abbreviations .....	5
3.1 Definitions .....	5
3.2 Symbols.....	5
3.3 Abbreviations .....	5
4 Inner physical layer - Single Carrier .....	6
4.1 Interfacing to OPL (Outer Physical Layer) .....	6
4.2 The profile approach - different single carrier modes .....	7
4.3 Generation of one Phy section.....	7
4.3.1 Overview .....	7
4.3.1.1 Overview of mode 1 .....	8
4.3.1.2 Overview of mode 2.....	9
4.3.2 IPL-SC signalling and padding.....	9
4.3.3 Energy dispersal (scrambling) .....	10
4.3.4 Preamble insertion .....	10
4.3.4.1 Mode 1: Preamble choice.....	11
4.3.4.2 Mode 2: Preamble choice.....	11
4.4 Bit mapping to constellation.....	12
4.4.1 QPSK Modulation .....	12
4.4.2 8PSK Modulation .....	13
4.4.3 16APSK Modulation.....	13
4.5 Pulse shaping.....	14
5 Parameter selection.....	14
5.1 Example 1: profile IPL-SC-A: symbol rate of 4,31 Msps .....	15
5.2 Example 2: profile IPL-SC-A: symbol rate of 4,33 Msps .....	15
5.3 Example 3: profile IPL-SC-A: symbol rate of 4,33 Msps .....	16
5.4 Example 4: profile IPL-SC-A: symbol rate of 10,87 Msps .....	17
5.5 Example 5: profile IPL-SC-B: symbol rate of 1,84 Msps .....	17
5.6 Example 6: profile IPL-SC-B: symbol rate of 1,49 Msps .....	18
<b>Annex A (informative): Bibliography.....</b>	<b>19</b>
History .....	20

---

## Intellectual Property Rights

IPRs essential or potentially essential to the present document may have been declared to ETSI. The information pertaining to these essential IPRs, if any, is publicly available for **ETSI members and non-members**, and can be found in ETSI SR 000 314: "*Intellectual Property Rights (IPRs); Essential, or potentially Essential, IPRs notified to ETSI in respect of ETSI standards*", which is available from the ETSI Secretariat. Latest updates are available on the ETSI Web server (<http://webapp.etsi.org/IPR/home.asp>).

Pursuant to the ETSI IPR Policy, no investigation, including IPR searches, has been carried out by ETSI. No guarantee can be given as to the existence of other IPRs not referenced in ETSI SR 000 314 (or the updates on the ETSI Web server) which are, or may be, or may become, essential to the present document.

---

## Foreword

This Technical Specification (TS) has been produced by ETSI Technical Committee Satellite Earth Stations and Systems (SES).

An SDR system enables broadcast to fixed and mobile receivers through satellites and complementary terrestrial transmitters. Functionalities, architecture and technologies of such systems are described in TR 102 525 (see bibliography).

The present document is part 1 of a multi-part deliverable covering the Satellite Digital Radio (SDR) Systems; Inner Physical Layer of the Radio Interface, as identified below:

**Part 1: "Single carrier transmission";**

Part 2: "Multiple carrier transmission".

Several existing and planned ETSI standards specify parts of the SDR system, with the aim of interoperable implementations. The physical layer of the radio interface (air interface) is divided up into the outer physical layer, the inner physical layer with a single carrier transmission, and the inner physical layer with multiple carriers transmission. These parts can be used all together in SDR compliant equipment, or in conjunction with other existing and future specifications.

The present document specifies the inner physical layer with single carrier transmission. The inner physical layer with multiple carrier transmission is specified in TS 102 551-2 (see bibliography), and the outer physical layer in TS 102 550 (see bibliography).

---

# 1 Scope

The present document concerns the radio interface of SDR broadcast receivers. It specifies functionality of the inner physical layer. It allows implementing this part of the system in an interoperable way. The present document specifies the case of single carrier transmission, whereas TS 102 551-2 (see bibliography) specifies multiple carrier transmission.

---

## 2 References

Void.

---

## 3 Definitions, symbols and abbreviations

### 3.1 Definitions

For the purposes of the present document, the following terms and definitions apply:

**floor function:** function that rounds number down, towards zero, to the nearest integer

### 3.2 Symbols

For the purposes of the present document, the following symbols apply:

$\alpha$  roll off factor

### 3.3 Abbreviations

For the purposes of the present document, the following abbreviations apply:

16APSK	16 Amplitude and Phase Shift Keying
8PSK	8 Phase Shift Keying
BW	BandWidth
C/N	Carrier to Noise ratio
C-TS	Channel Transport Stream
CU	Capacity Unit
DVB	Digital Video Broadcasting
I	In-phase
IPL	Inner Physical Layer
IPL-MC	Inner Physical Layer, Multiple Carrier
IPL-SC	Inner Physical Layer, Single Carrier
ISI	Inter Symbol Interference
LSB	Least Significant Bit
MSB	Most Significant Bit
OPL	Outer Physical Layer
Q	Quadrature
QPSK	Quaternary Phase Shift Keying
RF	Radio Frequency
RFU	Reserved for Future Use
S-TS	Service Transport Stream
TS	ETSI Technical Specification

## 4 Inner physical layer - Single Carrier

The functionality of the Inner Physical Layer (Single Carrier), in the following denoted IPL-SC, is to provide a robust modulation scheme for single carrier transmissions. The single carrier transmission is mainly applicable to satellite signal transmission but may be reused in other transmission environments. However, certain parameters are especially designed and optimized for satellite requirements.

The IPL-SC is embedded between the OPL (C-TS delivery) and the RF frontend (modulation) as depicted in Figure 1.

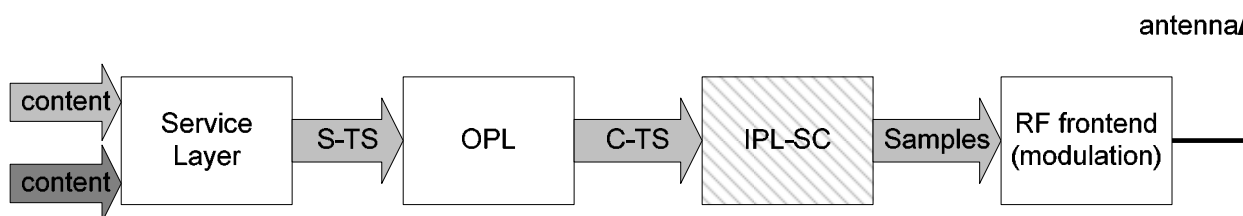

**Figure 1: General block diagram of the ETSI SES SDR system concept with selection of IPL-SC**

The general block diagram of the IPL-SC functionality is given in Figure 2. Please notify that the generation of each Phy section can be handled individually (dashed box), whereas rolloff filtering is applied to the stream of mapped symbols of many Phy section (due to its dispersive nature).

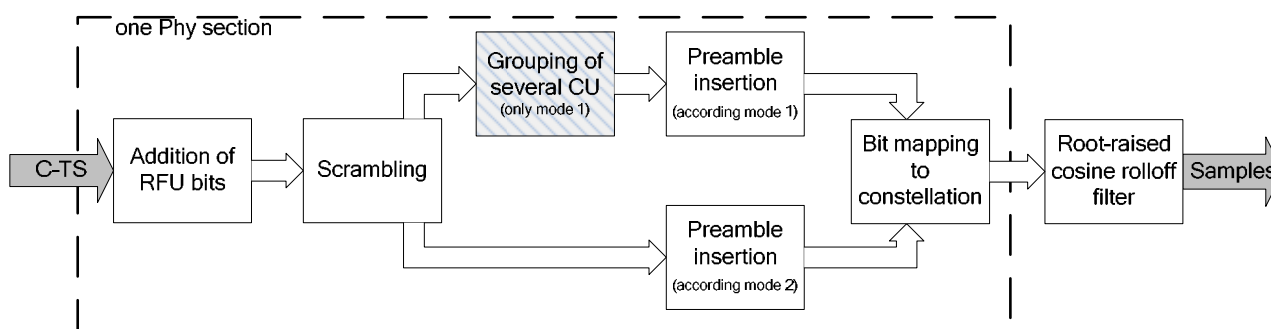

**Figure 2: Block diagram of the ETSI SES SDR compliant IPL-SC**

### 4.1 Interfacing to OPL (Outer Physical Layer)

Its interface to the OPL (Outer Physical Layer) is the C-TS (channel transport stream), which is defined in TS 102 550 (see bibliography). For this special IPL-SC, the parameters which are passed to the OPL are derived within TS 102 550 (see bibliography).

This IPL-SC provides an input for only one single C-TS and generates the signal for one RF carrier. If more than one carrier need to be supported, multiple instances of the IPL-SC need to be instantiated in parallel.

The parameters that are passed to the OPL are as follows:

- frame length in integer number of CU (capacity units)
- frame length in number of IPL-SC symbols

One IPL-SC frame is composed by a number of Phy sections. Their parameters are denoted in clause 5.

As different modes are distinguished (see clause 4.3), the interfacing to the OPL is also slightly different for the two modes:

- For mode 1, it is mandatory to have integer numbers of CU which can be divided without remainder by 2 (for QPSK), by 3 (for 8PSK) and by 4 (for 16APSK). Other numbers of CU lead to Phy sections that miss some CU, and non-periodic preamble structure would be introduced.

- For mode 2, it is desirable to have integer numbers of CU which can be divided without remainder by 2 (for QPSK), by 3 (for 8PSK) and by 4 (for 16APSK). Other numbers of CU lead to non-periodic preamble structure for the different modulation orders.

Examples for a reasonable choice of parameters are given in clause 5.

With these parameters, the exact throughput of the IPL-SC can be derived in CU per time, expressed here in number of IPL-SC symbols. The smallest unit to be processed by the IPL-SC is one CU.

To be able to benefit from the gain of hybrid configurations (e.g. using IPL-SC together with IPL-MC), it is mandatory to have equal frame lengths on both IPLs.

If modes 2, 3 or 4 of the IPL-MC TS 102 551-2, were used, the joint frame length of 432 ms is chosen for the IPL-MC frame length.

For mode 1 of the IPL-MC TS 102 551-2, the joint frame length is 487,424 ms ( $4 \times 121,856$  ms) or 438,68 ms ( $4 \times 109,67$  ms), dependent on the selection of the guard interval.

## 4.2 The profile approach - different single carrier modes

To cope with different design constraints that arise from the possible use scenarios of the IPL-SC, two modes (denoted mode 1 and mode 2) are defined which use a different share of pilots.

These modes are associated to profiles that are distinguished by their symbol rate and number of capacity units per inserted preamble, so that their adaptation to different channel bandwidths is easily possible. Profile IPL-SC-A is related to mode 1, and IPL-SC-B is related to mode 2, respectively.

For each profile, two examples are given. To comply with the different profiles, profile IPL-SC-A needs to be capable to work with all symbol rates ranging from 3 Msps up to 12 Msps. If compliance with profile IPL-SC-B is desired, symbol rates ranging from 1 Msps up to 3 Msps need to be supported.

The main target frequency bands and channel bandwidths are:

**Table 1: Different examples for the two profiles IPL-SC-A and IPL-SC-B**

	<b>S-Band 4,31 Msps</b>	<b>S-Band 4,33 Msps</b>	<b>S-Band 4,33 Msps</b>	<b>L-Band 10,87 Msps</b>	<b>L-Band 1,84 Msps</b>	<b>L-Band or S-Band 1,49 Msps</b>
<b>Profile name</b>	IPL-SC-A	IPL-SC-A	IPL-SC-A	IPL-SC-A	IPL-SC-B	IPL-SC-B
<b>Supported modes</b>	1	1	1	1	2	2
<b>Carrier frequency</b>	2,0 GHz to 2,3 GHz	2,0 GHz to 2,3 GHz	2,0 GHz to 2,3 GHz	1,4 GHz to 1,5 GHz	1,4 GHz to 1,5 GHz	1,4 GHz to 1,5 GHz 2,0 GHz to 2,3 GHz
<b>Channel bandwidth</b>	4,96 MHz	4,98 MHz	4,98 MHz	12,5 MHz	2,12 MHz	1,71 MHz
<b>Symbol rate</b>	4,31 Msps	4,33 Msps	4,33 Msps	10,87 Msps	1,84 Msps	1,49 Msps
<b>min/max symbol rate</b>	3 Msps / 12 Msps	3 Msps / 12 Msps	3 Msps / 12 Msps	3 Msps / 12 Msps	1 Msps / 3 Msps	1 Msps / 3 Msps
<b>IPL-SC frame length</b>	432 ms	487,424 ms	438,68 ms	432 ms	432 ms	432 ms

The present document does not restrict its use to the application scenarios as denoted above. Other frequency bands or channel bandwidths may be used but the parameter selection may not be optimal.

## 4.3 Generation of one Phy section

### 4.3.1 Overview

One Phy section consists of the following 3 parts:

- preamble;
- data payload (capacity units, CU, etc.);
- signalling bits (RFU: reserved for future use).

Insertion of preambles is different for mode 1 and mode 2, therefore the preamble insertion is distinguished within the following clauses.

#### 4.3.1.1 Overview of mode 1

Figure 3 displays the generation of one Phy section in mode 1.

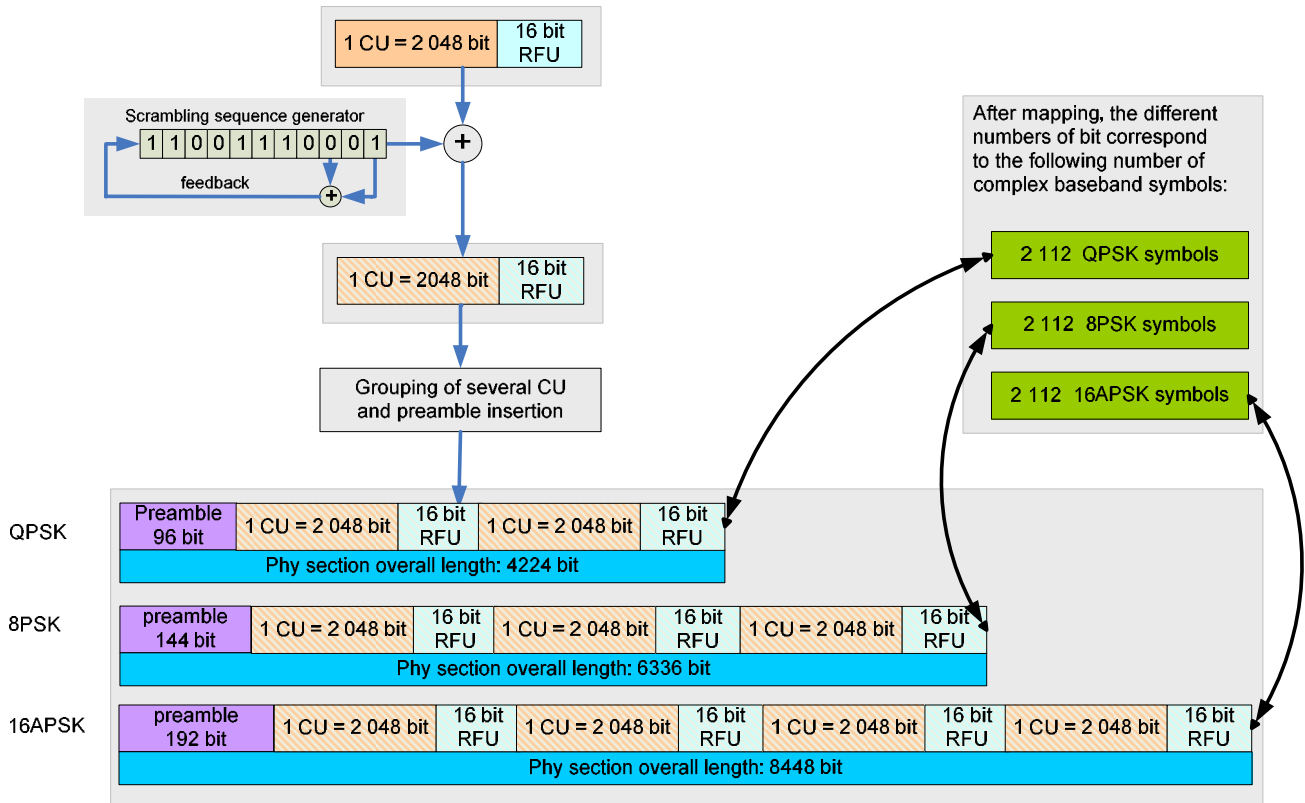

**Figure 3: Overview of the generation of one Phy section in mode 1**

The length of one Phy section (in bit) depends on the chosen modulation order. The number of complex baseband symbols after mapping is kept constant in mode 1 to be 2 112 symbols for all three modulation orders. The procedure to generate one Phy section is described below.



### 4.3.1.2 Overview of mode 2

Figure 4 displays the generation of one Phy section in mode 2.

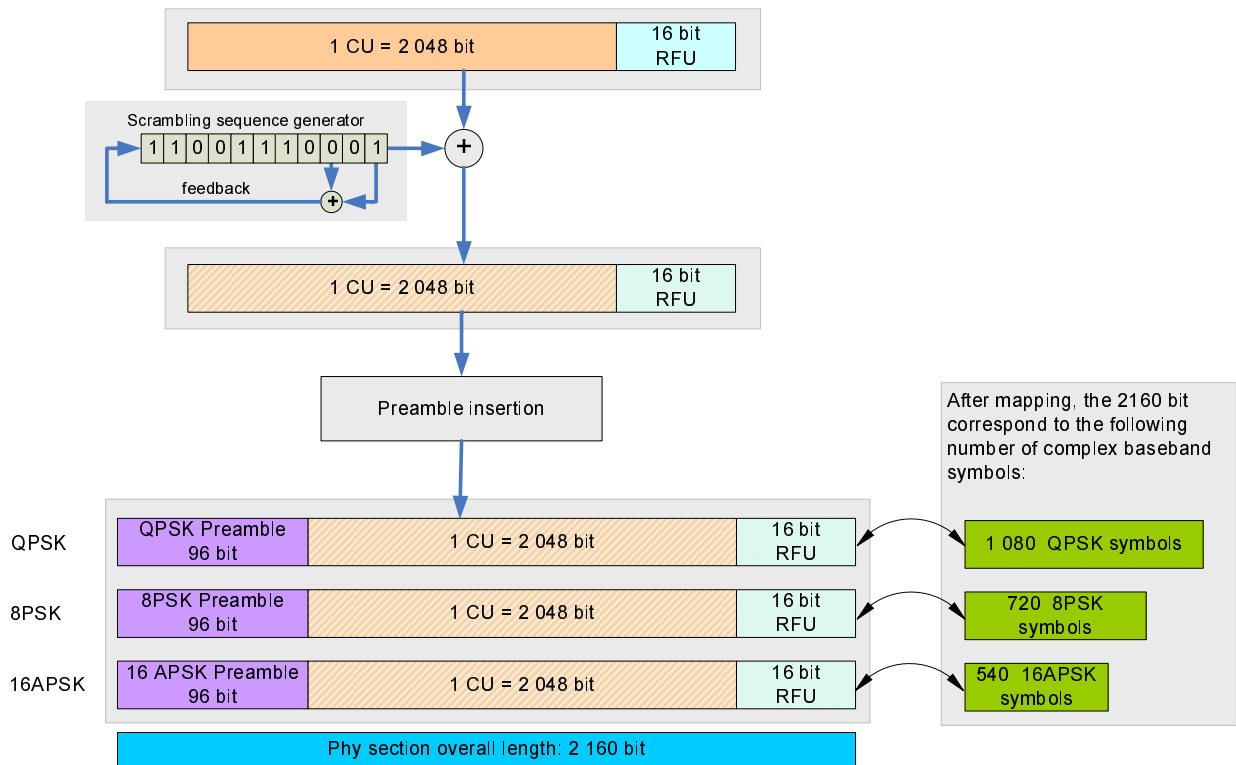

**Figure 4: Overview of the generation of one Phy section in mode 2**

The length of the Phy section is defined as 2160 bits as depicted in Figure 4. The procedure to generate one Phy section is described in the following clauses.

### 4.3.2 IPL-SC signalling and padding

There is no signalling of transmission parameters of the IPL-SC. All transmission parameters (e.g. modulation order) can be derived from the preambles. To be able to distinguish different modulation modes, different preambles are selected.

Each CU is followed by 16 signalling bits which are currently not used but are reserved for future use. All bits are set to zero. Therefore, the block sizes for one CU after bit padding are 2064 bit. See also Figure 3 and Figure 4.

Bit padding at the end of one IPL-SC frame: Bit padding at the end of the IPL-SC frame is not required as the transport capability of one IPL-SC frame is always an integer number of Phy sections. This is ensured by the selection of the symbol rate and the frame length.

CU padding at the end of one C-TS frame: As it is a mandatory requirement of the C-TS multiplexer at the output of the OPL to adapt the number of CU to the transport capability of the IPL-SC, no additional padding of empty CU is necessary; however, padding of empty CU may be foreseen to support such erroneous situations.

### 4.3.3 Energy dispersal (scrambling)

Energy dispersal is applied to the data payload and the 16 RFU bits. The energy dispersal is performed using a length 2 047 ( $2^{11} - 1$ ) scrambler with an internal shift register of length 11. The scrambler is described using the following generator polynomial as derived from ITU-T Recommendation O.153 (see bibliography):

$X^{11} + X^9 + 1$ , initial state is set to "11001110001" (see Figure 5)

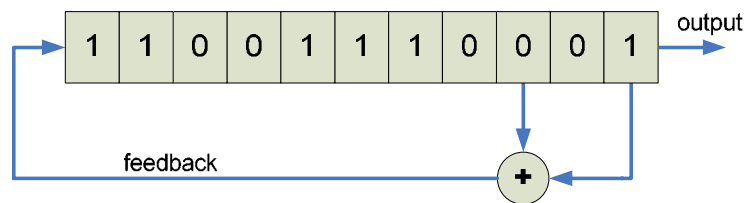

**Figure 5: Scrambler used for energy dispersal**

The output of the scrambler of length 2 064 is XORed with the first 2064 bit of the bitstream as depicted in Figure 3 and Figure 4. The scrambler is initialized each start of one CU and each start of the padding section. If the size of the data that has to be scrambled exceeds the one cycle of the scrambler, the scrambler just continues periodically.

### 4.3.4 Preamble insertion

The preambles are inserted into the bitstream before the mapping. The preambles are located directly in front of the payload data.

All preambles use only two distinct data points of the constellation diagram. These two data points can be seen as a rotated BSPK so the detection of the preamble may be reduced to find binary signals only. Furthermore, any non data-aided symbol timing recovery algorithm does not get in trouble when passing through the pilots due to the selection of the points.

#### 4.3.4.1 Mode 1: Preamble choice

If mode 1 is selected, the preambles are inserted according to the chosen modulation format and Table 2.

**Table 2: Preambles for mode 1**

Modulation	Preamble length in symbols	Preamble length in bit	Preamble distance in symbols	Preamble symbol sequence taken from the two symbols $s_1 = \rho \times \exp(j \times \pi/4)$ , $s_2 = \rho \times \exp(j \times 5 \times \pi/4)$ ( $\rho$ equals 1 for QPSK and 8PSK, but for 16APSK, $\rho$ equals $R_2$ as defined in Table 4)	Mapped preamble bit sequence taken from the constellation
<b>QPSK</b>	48	96	2 112	{ s1, s1, s2, s2, s2, s2, s1, s1, s1, s1, s2, s1, s1, s2, s1, s2, s1, s2, s1, s1, s1, s2, s1, s1, s1, s2, s2, s2, s1, s2, s2, s1, s2, s1, s2, s1, s1, s1, s1, s2, s1, s2 }	{ 00, 00, 11, 11, 11, 11, 00, 00, 00, 00, 11, 00, 00, 11, 00, 11, 00, 11, 00, 11, 00, 00, 00, 11, 00, 00, 11, 00, 11, 00, 00, 00, 11, 11, 11, 00, 11, 11, 00, 11, 00, 11, 00, 00, 00, 00, 11, 00, 00, 00, 11, 00, 00, 11 }
<b>8PSK</b>	48	144	2 112	{ s1, s1, s2, s2, s1, s1, s2, s1, s2, s2, s2, s2, s1, s1, s1, s1, s1, s1, s2, s2, s1, s1, s1, s1, s1, s1, s1, s1, s2, s1, s2, s1, s2, s1, s2, s1, s2, s2, s2, s2, s2, s1, s2, s1, s2, s2, s1, s2, s2, s2, s2 }	{ 000, 000, 011, 011, 000, 000, 011, 000, 011, 011, 011, 011, 011, 000, 000, 000, 000, 000, 000, 011, 011, 000, 000, 000, 000, 000, 000, 011, 011, 000, 000, 000, 000, 000, 000, 011, 000, 011, 000, 011, 000, 011, 000, 011, 011, 011, 011, 011, 000, 011, 000, 011, 011, 000, 011, 011, 000, 011, 011 }
<b>16APSK</b>	48	192	2 112	{ s1, s1, s1, s2, s2, s2, s2, s1, s2, s1, s1, s1, s1, s2, s1, s2, s1, s1, s1, s2, s2, s1, s2, s1, s1, s2, s1, s2, s1, s2, s2, s2, s2, s2, s1, s1, s1, s2, s1, s1, s1, s1, s1, s2, s1 } $\times R_2$	{ 0000, 0000, 0000, 0011, 0011, 0011, 0011, 0000, 0011, 0000, 0000, 0000, 0011, 0000, 0000, 0000, 0000, 0011, 0000, 0011, 0000, 0000, 0000, 0011, 0000, 0011, 0000, 0000, 0000, 0011, 0000, 0000, 0000, 0011, 0000, 0011, 0000, 0000, 0011, 0011, 0011, 0011, 0011, 0011, 0000, 0011, 0000, 0000, 0000, 0000, 0011, 0000, 0000, 0000, 0000 }

Remark on the choice of constellation points for 16APSK:  $R_2$  is defined in section 4.4.3. As the 16APSK modulation does not use constant envelope modulation, the preamble in 16APSK which makes use of the outer points of the constellation is slightly boosted (approximately 1,1 dB). In case of transponder non-linearities, the relative radius between outer and inner circle changes. To maintain a constant ratio between outer points and preamble points, the preamble uses therefore the same amplitude as the outer circle of the 16APSK constellation.

#### 4.3.4.2 Mode 2: Preamble choice

If mode 2 is selected, the preambles are inserted according to the chosen modulation format and Table 3.

Table 3: Preambles for mode 2

Modulation	Preamble length in symbols	Preamble length in bit	Preamble distance in symbols	Preamble symbol sequence taken from the two symbols $s_1 = \rho \times \exp(j \times \pi/4)$ , $s_2 = \rho \times \exp(j \times 5 \times \pi/4)$ ( $\rho$ equals 1 for QPSK and 8PSK, but for 16APSK, $\rho$ equals $R_2$ as defined in Table 4)	Mapped preamble bit sequence taken from the constellation
QPSK	48	96	1 080	{ s1, s1, s1, s1, s1, s2, s2, s1, s2, s2, s1, s2, s1, s1, s2, s1, s1, s1, s2, s1, s2, s1, s1, s1, s1, s2, s1, s1, s1, s2, s1, s2, s1, s2, s1, s2, s2, s1, s2, s2, s2, s1 }	{ 00, 00, 00, 00, 00, 11, 11, 00, 11, 11, 00, 11, 00, 00, 11, 00, 00, 00, 11, 11, 00, 11, 00, 00, 00, 00, 11, 00, 00, 00, 11, 00, 00, 00, 11, 00, 11, 00, 11, 00, 11, 00, 11, 11, 00, 11, 11, 11, 00 }
8PSK	32	96	720	{ s1, s1, s1, s1, s2, s1, s2, s2, s2, s1, s1, s1, s1, s2, s1, s1, s2, s1, s2, s1, s2, s1, s2, s2, s2, s2, s2, s2 }	{ 000, 000, 000, 000, 011, 000, 011, 011, 011, 000, 000, 000, 000, 000, 011, 000, 000, 011, 000, 011, 000, 011, 011, 000, 011, 011, 011, 011, 011, 011, 011, 011 }
16APSK	24	96	540	{ s2, s1, s2, s1, s1, s2, s2, s2, s2, s2, s1, s2, s2, s2, s2, s2, s1, s1, s1, s2, s2, s1, s2, s2, s2 } $\times R_2$	{ 0011, 0000, 0011, 0000, 0000, 0011, 0011, 0011, 0011, 0011, 0000, 0011, 0011, 0011, 0011, 0000, 0000, 0000, 0011, 0011, 0000, 0011, 0011, 0011 }

Remark on the choice of constellation points for 16APSK:  $R_2$  is defined in clause 4.4.3. As the 16APSK modulation does not use constant envelope modulation, the preamble in 16APSK which makes use of the outer points of the constellation is slightly boosted (approximately 1,1 dB). In case of transponder non-linearities, the relative radius between outer and inner circle changes. To maintain a constant ratio between outer points and preamble points, the preamble uses therefore the same amplitude as the outer circle of the 16APSK constellation.

Using different preamble lengths for the different modulation orders in mode 2 are justified by the following considerations: The lower the available C/N, the lower typically the modulation order is. With lower modulation orders, higher gain from longer preambles is necessary. On the other hand, due to the lower sensitivity of lower modulation orders to remaining phase noise, the distance of the preambles is higher. In total, the pilot overhead is constant for all modulation orders, approximately 4,4 % or 0,18 dB. Taking into account the slightly boosted preamble of 16APSK, this value changes to approximately 5,6 % or 0,25 dB.

## 4.4 Bit mapping to constellation

The mapping of each Phy section is performed according to the following mapping schemes which have been adopted from the DVB-S2 standard EN 302 307 (see bibliography). The notation of the bits is as follows:

The leftmost bit is to be extracted from the input bitstream first, whereas the rightmost bit is to be extracted from the input bitstream as the last one.

### 4.4.1 QPSK Modulation

The following mapping scheme is used in QPSK modulation mode, denoted as modulation index 2. See also Figure 6. The transmission order is {bit[i] bit[i+1]} where i denotes the current time index.

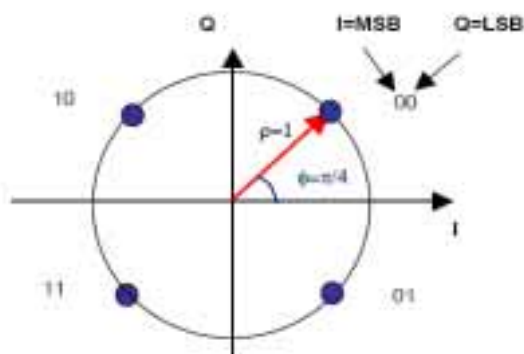

Figure 6: QPSK modulation

#### 4.4.2 8PSK Modulation

The following mapping scheme is used in 8PSK modulation mode, denoted as modulation index 3. See also Figure 7. The transmission order is  $\{\text{bit}[i] \text{ bit}[i+1] \text{ bit}[i+2]\}$  where  $i$  denotes the current time index.

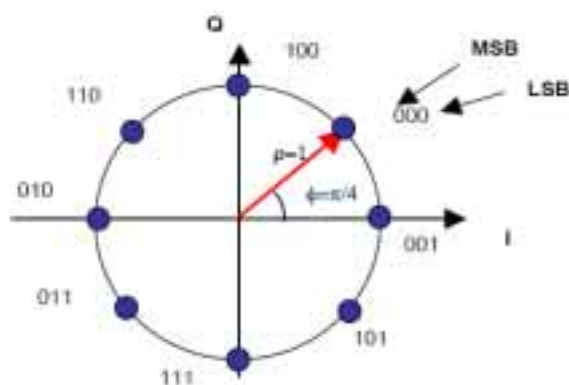

Figure 7: 8PSK Modulation

#### 4.4.3 16APSK Modulation

The following mapping scheme is used in 16APSK modulation mode, denoted as modulation index 4. See also Figure 8. The transmission order is  $\{\text{bit}[i] \text{ bit}[i+1] \text{ bit}[i+2] \text{ bit}[i+3]\}$  where  $i$  denotes the current time index.

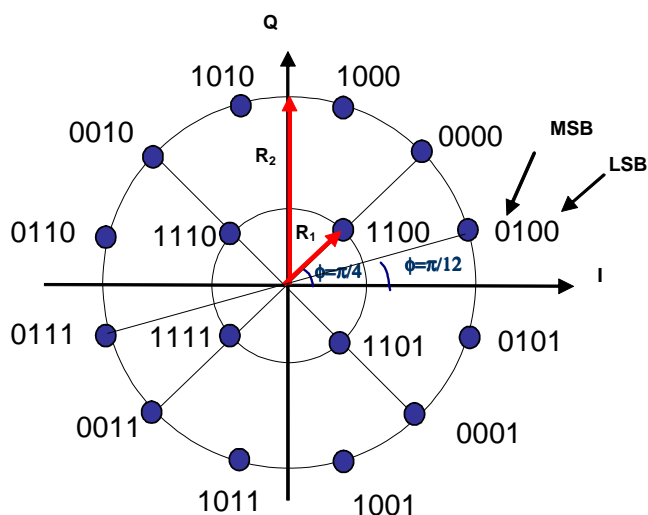

Figure 8: 16APSK modulation

In 16APSK mode, the radii of the two circles have to be chosen accordingly to Table 4 to ensure equal mean power ratio between all modulation modes.

**Table 4: Definition of radii for the two circles of the 16APSK constellation**

Circle	Radius
Inner	$R_1 = 1/\sqrt{7}$
Outer	$R_2 = 3/\sqrt{7}$

## 4.5 Pulse shaping

Pulse shaping is performed on the whole mapped stream of symbols. To comply with regulatory bodies, the bandwidth of the transmitted signal needs to be band limited prior to digital-to-analog conversion, up conversion and amplification. Therefore, a (real-valued) root-raised cosine roll off filter is applied to the I and Q component, respectively. If the same filter was also applied at the receiver side, the signal could be detected ISI-free (free of inter symbol interference) in a non-dispersive channel.

The available roll off factor is  $\alpha=0,15$ . Any mismatch to existing roll off factors in the receivers (e.g. 0,20 or 0,25) is negligible, so other roll-off factors are not specified. However, other values of the roll-off factors may be considered optionally on the transmitter side. This would be the case if small overlaps of frequency bands are tolerated or the transmitters are already in situ.

For the pulse shaping, the following formula applies:

$$\begin{aligned}
 H(f) &= 1 & \text{for } |f| < f_N(1 - \alpha) \\
 H(f) &= \left\{ \frac{1}{2} + \frac{1}{2} \sin \frac{\pi}{2f_N} \left[ \frac{f_N - |f|}{\alpha} \right] \right\}^{1/2} & \text{for } f_N(1 - \alpha) \leq |f| \leq f_N(1 + \alpha) \\
 H(f) &= 0 & \text{for } |f| > f_N(1 + \alpha),
 \end{aligned}$$

where  $f_N = \frac{f_s}{2}$  denotes the Nyquist frequency,  $f_s$  the symbol frequency and  $\alpha$  the roll-off factor.

---

## 5 Parameter selection

The following parameters have been derived for different scenarios:

- profile IPL-SC-A: symbol rate of 4,31 Msps (5 MHz channel grid, mode 1, frame length 432 ms)
- profile IPL-SC-A: symbol rate of 4,33 Msps (5 MHz channel grid, mode 1, frame length 487,42 ms)
- profile IPL-SC-A: symbol rate of 4,33 Msps (5 MHz channel grid, mode 1, frame length 438,68 ms)
- profile IPL-SC-A: symbol rate of 10,87 Msps (12,5 MHz channel grid, mode 1, frame length 432 ms)
- profile IPL-SC-B: symbol rate of 1,84 Msps (2,1 MHz channel grid, mode 2, compliant to existing satellites, frame length 432 ms)
- profile IPL-SC-B: symbol rate of 1,49 Msps (1,7 MHz channel grid, mode 2, compliant to EU 147 spectrum mask, frame length 432 ms)

The selection of the symbol rates has been made according to the following formulas providing means to avoid padding on the IPL-SC and to achieve maximum bandwidth occupation within the given frequency constraints:

For mode 1, the symbol rate has been derived as follows:

$$f_{\text{Symbol}}(\text{kHz}) = (\text{nCUperFrame}/\text{nCUperPreamble}) \times 44/9;$$

with  $\text{nCUperFrame} = 18 \times \text{floor}(\text{BW}/((1+\alpha)/88)) \times \text{nCUperPreamble}$  and BW denoted in kHz

For mode 2, the symbol rate has been derived as follows:

$$f_{\text{Symbol}} (\text{kHz}) = (n_{\text{CUperFrame}}/n_{\text{CUperPreamble}}) \times 5;$$

with  $n_{\text{CUperFrame}} = \text{floor}(\text{BW}/(1+\alpha)/5) \times n_{\text{CUperPreamble}}$  and BW denoted in kHz

## 5.1 Example 1: profile IPL-SC-A: symbol rate of 4,31 Msps

To comply with profile IPL-SC-A, mode 1 must be supported due to the usage of a symbol rate larger than 3 Msps. This example has been designed to work in a channelization of 5 MHz. All three modulation orders (i.e. QPSK, 8PSK and 16APSK) are mandatory. The frame length is 432 ms.

**Table 5: Parameters derived for profile IPL-SC-A with a symbol rate of 4,31 Msps and frame length of 432 ms**

Parameter description	Parameter symbol	unit	QPSK	8PSK	16APSK
			mandatory	mandatory	mandatory
symbol rate	$f_{\text{Symbol}}$	kHz	4 312	4 312	4 312
roll-off factor	a	percent	15	15	15
occupied bandwidth	BW	kHz	4 959	4 959	4 959
modulation index	modIndex		2	3	4
IPL-SC frame length	tFrame	ms	432	432	432
symbols per IPL-SC frame	nSymbolsPerFrame		1 862 784	1 862 784	1 862 784
CU length	CULength	bit	2 064	2 064	2 064
preamble length	PreaLength	bit	96	144	192
CU per preamble	nCUperPreambls		2	3	4
Phy section length	PhySecLength	bit	4 224	6 336	8 448
symbols per Phy section	nSymbolsPerPhySection		2 112	2 112	2 112
padding symbols per IPL-SC frame	nPaddingSymbolsPerFrame		0	0	0
padding bits per IPL-SC frame	nPaddingBitsPerFrame		0	0	0
<b>CU per frame</b>	nCUperFrame		<b>1 764</b>	<b>2 646</b>	<b>3 528</b>
preamble overhead		percent	2,27	2,27	2,27
preamble distance		ms	0,49	0,49	0,49
preamble repetition rate		Hz	2 041	2 041	2 041

## 5.2 Example 2: profile IPL-SC-A: symbol rate of 4,33 Msps

To comply with profile IPL-SC-A, mode 1 must be supported due to the usage of a symbol rate larger than 3 Msps. This example has been designed to work in a channelization of 5 MHz. All three modulation orders (i.e. QPSK, 8PSK and 16APSK) are mandatory. The frame length is  $4 \times 121,856$  ms to comply with IPL-MC, mode 1 and guard interval 1/4 framing.

**Table 6: Parameters derived for profile IPL-SC-A with a symbol rate of 4,33 Msps and frame length of 487,42 ms**

Parameter description	Parameter symbol	unit	QPSK	8PSK	16APSK
			mandatory	mandatory	mandatory
symbol rate	fSymbol	kHz	4 333	4 333	4 333
roll-off factor	a	percent	15	15	15
occupied bandwidth	BW	kHz	4 983	4 983	4 983
modulation index	modIndex		2	3	4
IPL-SC frame length	tFrame	ms	487,42	487,42	487,42
symbols per IPL-SC frame	nSymbolsPerFrame		2 112 000	2 112 000	2 112 000
CU length	CULength	bit	2 064	2 064	2 064
preamble length	PreaLength	bit	96	144	192
CU per preamble	nCUperPreambls		2	3	4
Phy section length	PhySecLength	bit	4 224	6 336	8 448
symbols per Phy section	nSymbolsPerPhySection		2 112	2 112	2 112
padding symbols per IPL-SC frame	nPaddingSymbolsPerFrame		0	0	0
padding bits per IPL-SC frame	nPaddingBitsPerFrame		0	0	0
<b>CU per frame</b>	nCUperFrame		<b>2 000</b>	<b>3 000</b>	<b>4 000</b>
preamble overhead		percent	2,27	2,27	2,27
preamble distance		ms	0,49	0,49	0,49
preamble repetition rate		Hz	2 041	2 041	2 041

### 5.3 Example 3: profile IPL-SC-A: symbol rate of 4,33 Msps

To comply with profile IPL-SC-A, mode 1 must be supported due to the usage of a symbol rate larger than 3 Msps. This example has been designed to work in a channelization of 5 MHz. All three modulation orders (i.e. QPSK, 8PSK and 16APSK) are mandatory. The frame length is  $4 \times 109,670$  ms to comply with IPL-MC, mode 1 and guard interval 1/8 framing.

**Table 7: Parameters derived for profile IPL-SC-A with a symbol rate of 4,33 Msps and frame length of 438,68 ms**

Parameter description	Parameter symbol	unit	QPSK	8PSK	16APSK
			mandatory	mandatory	mandatory
symbol rate	fSymbol	kHz	4 333	4 333	4 333
roll-off factor	a	percent	15	15	15
occupied bandwidth	BW	kHz	4 983	4 983	4 983
modulation index	modIndex		2	3	4
IPL-SC frame length	tFrame	ms	438,68	438,68	438,68
symbols per IPL-SC frame	nSymbolsPerFrame		1 900 800	1 900 800	1 900 800
CU length	CULength	bit	2 064	2 064	2 064
preamble length	PreaLength	bit	96	144	192
CU per preamble	nCUperPreambls		2	3	4
Phy section length	PhySecLength	bit	4 224	6 336	8 448
symbols per Phy section	nSymbolsPerPhySection		2 112	2 112	2 112
padding symbols per IPL-SC frame	nPaddingSymbolsPerFrame		0	0	0
padding bits per IPL-SC frame	nPaddingBitsPerFrame		0	0	0
<b>CU per frame</b>	nCUperFrame		<b>1 800</b>	<b>2 700</b>	<b>3 600</b>
preamble overhead		percent	2,27	2,27	2,27
preamble distance		ms	0,49	0,49	0,49
preamble repetition rate		Hz	2 041	2 041	2 041



## 5.4 Example 4: profile IPL-SC-A: symbol rate of 10,87 Msps

To comply with profile IPL-SC-A, mode 1 must be supported due to the usage of a symbol rate larger than 3 Msps. This example has been designed to work in a channelization of 12,5 MHz. All three modulation orders (i.e. QPSK, 8PSK and 16APSK) are mandatory. The frame length is 432 ms.

**Table 8: Parameters derived for profile IPL-SC-A with a symbol rate of 10,87 Msps and frame length of 432 ms**

Parameter description	Parameter symbol	unit	QPSK	8PSK	16APSK
			mandatory	mandatory	mandatory
symbol rate	fSymbol	kHz	10 868	10 868	10 868
roll-off factor	a	percent	15	15	15
occupied bandwidth	BW	kHz	12 498	12 498	12 498
modulation index	modIndex		2	3	4
IPL-SC frame length	tFrame	ms	432	432	432
symbols per IPL-SC frame	nSymbolsPerFrame		4 694 976	4 694 976	4 694 976
CU length	CULength	bit	2 064	2 064	2 064
preamble length	PreaLength	bit	96	144	192
CU per preamble	nCUperPreamble		2	3	4
Phy section length	PhySecLength	bit	4 224	6 336	8 448
symbols per Phy section	nSymbolsPerPhySection		2 112	2 112	2 112
padding symbols per IPL-SC frame	nPaddingSymbolsPerFrame		0	0	0
padding bits per IPL-SC frame	nPaddingBitsPerFrame		0	0	0
<b>CU per frame</b>	nCUperFrame		<b>4 446</b>	<b>6 669</b>	<b>8 892</b>
preamble overhead		percent	2,27	2,27	2,27
preamble distance		ms	0,19	0,19	0,19
preamble repetition rate		Hz	5 263	5 263	5 263

## 5.5 Example 5: profile IPL-SC-B: symbol rate of 1,84 Msps

To comply with profile IPL-SC-B, mode 2 must be supported due to the usage of a symbol rate smaller than 3 Msps. This example has been designed to work with a fixed symbol rate of 1,84 MHz. Only the two lower modulation orders (i.e. QPSK and 8PSK) are mandatory whereas 16APSK may be included as an option.

**Table 9: Parameters derived for profile IPL-SC-B with a symbol rate of 1,84 Msps**

Parameter description	Parameter symbol	unit	QPSK	8PSK	16APSK
			mandatory	mandatory	optional
symbol rate	fSymbol	kHz	1 840	1 840	1 840
roll-off factor	a	percent	15	15	15
occupied bandwidth	BW	kHz	2 116	2 116	2 116
modulation index	modIndex		2	3	4
IPL-SC frame length	tFrame	ms	432	432	432
symbols per IPL-SC frame	nSymbolsPerFrame		794 880	794 880	794 880
CU length	CULength	bit	2 064	2 064	2 064
preamble length	PreaLength	bit	96	96	96
Phy section length	PhySecLength	bit	2 160	2 160	2 160
symbols per Phy section	nSymbolsPerPhySection		1 080	720	540
padding symbols per IPL-SC frame	nPaddingSymbolsPerFrame		0	0	0
padding bits per IPL-SC frame	nPaddingBitsPerFrame		0	0	0
<b>CU per frame</b>	nCUPerFrame		<b>736</b>	<b>1 104</b>	<b>1 472</b>
preamble overhead		percent	4,44	4,44	4,44
preamble distance		ms	0,59	0,39	0,29
preamble repetition rate		Hz	1 695	2 564	3 448

## 5.6 Example 6: profile IPL-SC-B: symbol rate of 1,49 Msps

To comply with profile IPL-SC-B, mode 2 must be supported due to the usage of a symbol rate smaller than 3 Msps. This example has been designed to work in a channelization of 1,7 MHz, derived from spectrum constraints as described in EU 147. Only the two lower modulation orders (i.e. QPSK and 8PSK) are mandatory whereas 16APSK may be included as an option.

**Table 10: Parameters derived for profile IPL-SC-B with a symbol rate of 1,49 Msps**

Parameter description	Parameter symbol	unit	QPSK	8PSK	16APSK
			mandatory	mandatory	optional
symbol rate	fSymbol	kHz	1 485	1 485	1 485
roll-off factor	a	percent	15	15	15
occupied bandwidth	BW	kHz	1 708	1 708	1 708
modulation index	modIndex		2	3	4
IPL-SC frame length	tFrame	ms	432	432	432
symbols per IPL-SC frame	nSymbolsPerFrame		641 520	641 520	641 520
CU length	CULength	bit	2 064	2 064	2 064
preamble length	PreaLength	bit	96	96	96
Phy section length	PhySecLength	bit	2 160	2 160	2 160
symbols per Phy section	nSymbolsPerPhySection		1 080	720	540
padding symbols per IPL-SC frame	nPaddingSymbolsPerFrame		0	0	0
padding bits per IPL-SC frame	nPaddingBitsPerFrame		0	0	0
<b>CU per frame</b>	nCUPerFrame		<b>594</b>	<b>891</b>	<b>1 188</b>
preamble overhead		percent	4,44	4,44	4,44
preamble distance		ms	0,73	0,48	0,36
preamble repetition rate		Hz	1 370	2 083	2 778

---

## Annex A (informative): Bibliography

ETSI EN 302 307 (V1.1.1): "Digital Video Broadcasting (DVB); Second generation framing structure, channel coding and modulation systems for Broadcasting, Interactive Services, News Gathering and other broadband satellite applications".

ITU-T Recommendation O.153 (1992): "Basic parameters for the measurement of error performance at bit rates below the primary rate".

ETSI TS 102 551-2 (V1.1.1): "Satellite Earth Stations and Systems (SES); Satellite Digital Radio (SDR) Systems; Inner Physical Layer of the Radio Interface Part 2 - Multiple Carrier Transmission".

ETSI TS 102 550 (V1.1.1): "Satellite Earth Stations and Systems (SES); Satellite Digital Radio (SDR) Systems; Outer Physical Layer of the Radio Interface".

ETSI TR 102 525 (V1.1.1): "Satellite Earth Stations and Systems (SES); Satellite Digital Radio (SDR) service; Functionalities, architecture and technologies".

---

## History

<b>Document history</b>		
V1.1.1	December 2006	Publication