

# ETSI TS 102 385-3 V2.1.2 (2006-03)

---

*Technical Specification*

## **Broadband Radio Access Networks (BRAN); HiperMAN/WiMAX; Conformance testing for the Data Link Control Layer (DLC); Part 3: Abstract Test Suite (ATS)**



---

Reference

RTS/BRAN-004T002-3R1a

---

Keywords

ATS, broadband, DLC, FWA, HiperMAN,  
Point-to-Multipoint, radio, testing

**ETSI**

650 Route des Lucioles  
F-06921 Sophia Antipolis Cedex - FRANCE

Tel.: +33 4 92 94 42 00 Fax: +33 4 93 65 47 16

Siret N° 348 623 562 00017 - NAF 742 C  
Association à but non lucratif enregistrée à la  
Sous-Préfecture de Grasse (06) N° 7803/88

---

**Important notice**

Individual copies of the present document can be downloaded from:

<http://www.etsi.org>

The present document may be made available in more than one electronic version or in print. In any case of existing or perceived difference in contents between such versions, the reference version is the Portable Document Format (PDF). In case of dispute, the reference shall be the printing on ETSI printers of the PDF version kept on a specific network drive within ETSI Secretariat.

Users of the present document should be aware that the document may be subject to revision or change of status. Information on the current status of this and other ETSI documents is available at

<http://portal.etsi.org/tb/status/status.asp>

If you find errors in the present document, please send your comment to one of the following services:

[http://portal.etsi.org/chaicor/ETSI\\_support.asp](http://portal.etsi.org/chaicor/ETSI_support.asp)

---

**Copyright Notification**

No part may be reproduced except as authorized by written permission.  
The copyright and the foregoing restriction extend to reproduction in all media.

© European Telecommunications Standards Institute 2006.

© WIMAX Forum 2006.

All rights reserved.

**DECT**<sup>TM</sup>, **PLUGTESTS**<sup>TM</sup> and **UMTS**<sup>TM</sup> are Trade Marks of ETSI registered for the benefit of its Members.  
**TIPHON**<sup>TM</sup> and the **TIPHON logo** are Trade Marks currently being registered by ETSI for the benefit of its Members.  
**3GPP**<sup>TM</sup> is a Trade Mark of ETSI registered for the benefit of its Members and of the 3GPP Organizational Partners.

# Contents

Intellectual Property Rights .....	5
Foreword.....	5
1 Scope .....	6
2 References .....	6
3 Definitions and abbreviations.....	7
3.1 Definitions .....	7
3.2 Abbreviations .....	7
4 Abstract Test Method (ATM).....	7
4.1 IEEE 802.16-2004 and ETSI HiperMAN protocol layers .....	7
4.2 Test architecture .....	8
5 Untestable Test Purposes (TP) .....	10
6 ATS conventions .....	10
6.1 Testing conventions.....	11
6.1.1 Testing States.....	11
6.1.2 HiperMAN default values: Reception and transmission at ATS level.....	11
6.1.3 Templates.....	11
6.1.4 Functions .....	11
6.2 Naming conventions.....	12
6.2.1 General guidelines .....	12
6.2.2 Test Case (TC) identifier .....	13
<b>Annex A (normative): Abstract Test Suite (ATS) .....</b>	<b>15</b>
A.1 The TTCN-3 Module.....	15
<b>Annex B (normative): Partial PIXIT proforma for HiperMAN DLC .....</b>	<b>16</b>
B.1 Identification summary.....	16
B.2 ATS summary .....	16
B.3 Test laboratory.....	16
B.4 Client identification.....	17
B.5 SUT .....	17
B.6 Protocol layer information.....	17
B.6.1 Protocol identification .....	17
B.6.2 IUT information .....	17
B.6.2.1 Timers .....	18
B.6.2.2 Common Configuration .....	18
B.6.2.3 DL-MAP message .....	18
B.6.2.4 DCD message .....	18
B.6.2.5 UCD message .....	18
B.6.2.6 RNG-REQ message .....	19
B.6.2.7 RNG-RSP message .....	19
B.6.2.8 SBC-REQ message .....	20
B.6.2.9 SBC-RSP message.....	20
B.6.2.10 REG-REQ message.....	21
B.6.2.11 REG-RSP message .....	22
B.6.2.12 Dynamic Service.....	23
B.6.2.13 BWA.....	23
B.6.2.14 Test adapter.....	23
<b>Annex C (normative): PCTR Proforma for HiperMAN DLC .....</b>	<b>24</b>

C.1	Identification summary.....	24
C.1.1	Protocol conformance test report.....	24
C.1.2	IUT identification.....	24
C.1.3	Testing environment.....	24
C.1.4	Limits and reservation.....	25
C.1.5	Comments.....	25
C.2	IUT Conformance status .....	25
C.3	Static conformance summary .....	25
C.4	Dynamic conformance summary.....	25
C.5	Static conformance review report.....	26
C.6	Test campaign report.....	26
C.7	Observations.....	27
<b>Annex D (informative): Bibliography.....</b>		<b>28</b>
History .....		29

---

## Intellectual Property Rights

IPRs essential or potentially essential to the present document may have been declared to ETSI. The information pertaining to these essential IPRs, if any, is publicly available for **ETSI members and non-members**, and can be found in ETSI SR 000 314: "*Intellectual Property Rights (IPRs); Essential, or potentially Essential, IPRs notified to ETSI in respect of ETSI standards*", which is available from the ETSI Secretariat. Latest updates are available on the ETSI Web server (<http://webapp.etsi.org/IPR/home.asp>).

Pursuant to the ETSI IPR Policy, no investigation, including IPR searches, has been carried out by ETSI. No guarantee can be given as to the existence of other IPRs not referenced in ETSI SR 000 314 (or the updates on the ETSI Web server) which are, or may be, or may become, essential to the present document.

---

## Foreword

This Technical Specification (TS) has been produced by ETSI Project Broadband Radio Access Networks (BRAN).

The present document was developed on the basis of the Abstract Test Suite (ATS) specification for HiperMAN systems that was in the advanced stage of development when the work was reoriented to produce joint HipeMAN/WiMAX specifications.

The present document is part 3 of a multi-part deliverable covering Broadband Radio Access Networks (BRAN); HiperMAN/WiMAX; Conformance testing for the Data Link Control Layer (DLC), as identified below:

Part 1: "Procolot Implementation Conformance Statement (PICS) proforma";

Part 2: "Test Suite Structure and Test Purposes (TSS&TP) specification";

**Part 3: "Abstract Test Suite (ATS)".**

---

# 1 Scope

The present document contains the Abstract Test Suite (ATS) to test BRAN HiperMAN/WiMAX systems for conformance.

The objective of the present document is to provide a basis for conformance tests for BRAN HiperMAN/WiMAX equipment giving a high probability of air interface inter-operability between different manufacturer's BRAN HiperMAN/WiMAX equipment.

TEXT needed from MIZ to explain that from now on only BRAN HiperMAN is mentioned. There is a mapping table in clause 4.1.

The ISO standard for the methodology of conformance testing (ISO/IEC 9646-1 [4] and ISO/IEC 9646-2 [5]) as well as the ETSI rules for conformance testing (ETS 300 406 [3]) are used as a basis for the test methodology.

Annex A provides the Tree and Tabular Combined Notation (TTCN) part of the ATS.

Annex B provides the Partial Protocol Implementation Extra Information for Testing (PIXIT) Proforma of the SS side ATS.

Annex C provides the Protocol Conformance Test Report (PCTR) Proforma of the SS side ATS.

---

# 2 References

The following documents contain provisions which, through reference in this text, constitute provisions of the present document.

- References are either specific (identified by date of publication and/or edition number or version number) or non-specific.
- For a specific reference, subsequent revisions do not apply.
- For a non-specific reference, the latest version applies.

Referenced documents which are not found to be publicly available in the expected location might be found at <http://docbox.etsi.org/Reference>.

- [1] ETSI TS 102 178 (V1.2.1): "Broadband Radio Access Networks (BRAN); HiperMAN; Data Link Control (DLC) layer".
- [2] IEEE P802.16-2004: "IEEE Standard for Local and Metropolitan area networks; Part 16: Air Interface for Fixed Broadband Wireless Access Systems".
- [3] ETSI ETS 300 406: "Methods for Testing and Specification (MTS); Protocol and profile conformance testing specifications; Standardization methodology".
- [4] ISO/IEC 9646-1/ITU-T Recommendation X.290: "Information technology - Open Systems Interconnection - Conformance testing methodology and framework - Part 1: General concepts".
- [5] ISO/IEC 9646-2/ITU-T Recommendation X.291: "Information technology - Open Systems Interconnection - Conformance testing methodology and framework - Part 2: Abstract Test Suite specification".
- [6] ISO/IEC 9646-6: "Information technology - Open Systems Interconnection - Conformance testing methodology and framework - Part 6: Protocol profile test specification".
- [7] ISO/IEC 9646-7: "Information technology - Open Systems Interconnection - Conformance testing methodology and framework - Part 7: Implementation Conformance Statements".
- [8] ETSI ES 201 873-1: "Methods for Testing and Specification (MTS); The Testing and Test Control Notation version 3; Part 1: TTCN-3 Core Language".

- [9] IEEE P802.16-2004/Cor1/D3: "Corrigendum to IEEE Standard for Local and Metropolitan Area Networks - Part 16: Air Interface for Fixed Broadband Wireless Access Systems".
- [10] ETSI TS 102 210: "Broadband Radio Access Networks (BRAN); HIPERMAN; System profiles".

## 3 Definitions and abbreviations

### 3.1 Definitions

For the purposes of the present document, the terms and definitions given in ISO/IEC 9646-7 [7], TS 102 178 [1], IEEE 802.16-2004 [2] and IEEE P802.16-2004/Cor1/D3 [9] apply.

### 3.2 Abbreviations

For the purposes of the present document, the abbreviations given in TS 102 178 [1], IEEE 802.16-2004 [2], ISO/IEC 9646-1 [4], ISO/IEC 9646-6 [6], ISO/IEC 9646-7 [7] and IEEE P802.16-2004/Cor1/D3 [9] and the following apply:

BS	Base Station
BW	BandWidth
CID	Connection Identifier
CS	Convergence Sublayer
FDD	Frequency Division Duplexing
OFDM	Orthogonal Frequency Division Multiplexing
OFDMA	Orthogonal Frequency Division Multiple Access
PMP	Point-to-MultiPoint
QAM	Quadrature Amplitude Modulation
QPSK	Quadrature Phase Shift Keying
REQ	REQuest
RNG	RaNGing
RSP	ReSPonse
RTG	Receive/Transmit Transition Gap
SS	Subscriber Station
TTG	Transmit/Receive Transition Gap

## 4 Abstract Test Method (ATM)

This clause describes the ATM used to test the HiperMAN DLC layer at the BS side and at the SS side.

### 4.1 IEEE 802.16-2004 and ETSI HiperMAN protocol layers

Figure 1 shows the mapping of the protocol layers of IEEE 802.16-2004 and ETSI HiperMAN. In the following clauses only the ETSI terminology will be referred to.

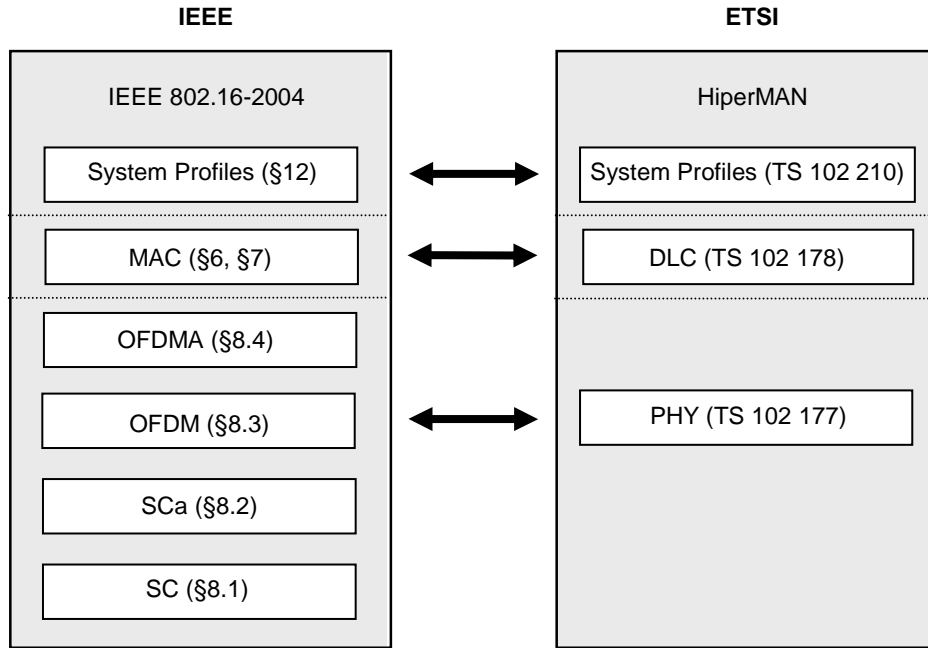

Figure 1: IEEE 802.16-2004 and ETSI HiperMAN protocol layers

## 4.2 Test architecture

Figure 2 describes the DLC BS/SS Test Configuration for testing the DLC layer of a product implementing the HiperMAN base standard. More information for this architecture is provided below.

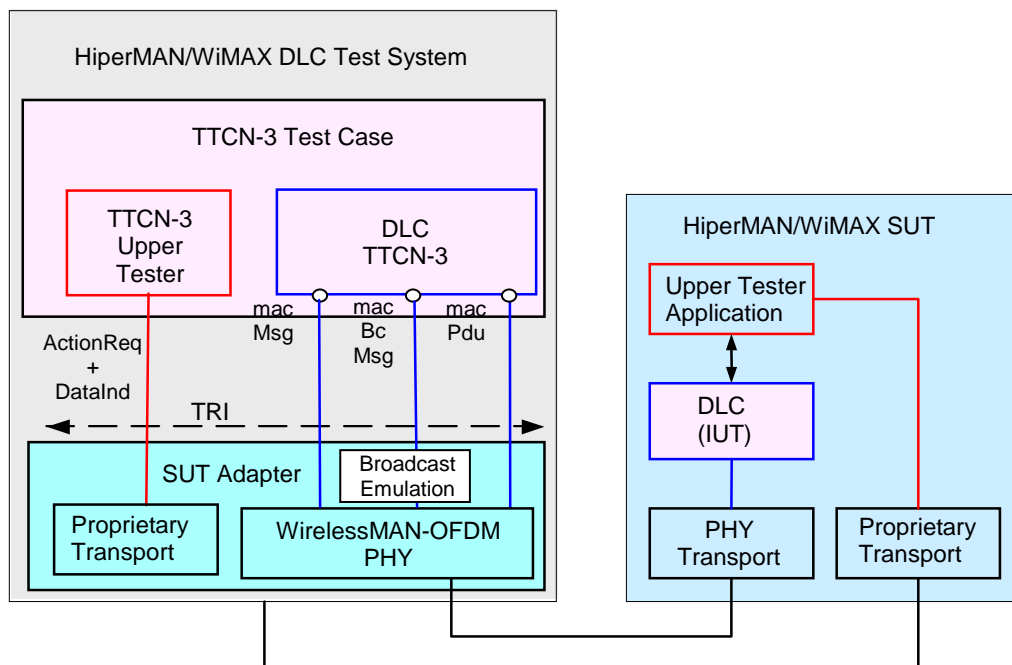

Figure 2: DLC BS/SS Test Configuration



The DLC BS/SS Test Configuration provides 1 test component:

- DLC TTCN-3 uses macMsg port to send and receive MAC management messages that belong to the Initial Ranging, Basic, Primary and Secondary connection. Final verdicts are set on the receive statements. The MAC management messages that the Test Adapter shall support are listed in table 1.
- DLC TTCN-3 uses macBcMsg port to receive MAC management messages that belong to the Broadcast connection. Final verdicts are set on the return status of the receive functions. The MAC management messages that the Test Adapter shall support are listed in table 2. The macBcMsg port is mapped only in the case, where explicitly the reception on the Broadcast connection is tested.
- DLC TTCN-3 uses macPdu port to send and receive MAC PDUs. Final verdicts are set on the receive statements. The MAC management PDUs that the Test Adapter shall support are listed in table 3.
- The broadcast emulation handles the sending and reception of the broadcast messages. TTCN-3 does not build the broadcast messages. TTCN-3 selects via xf\_enableProfile the profiles that the broadcast emulation shall sent.
- DLC TTCN-3 controls via external functions the Upper Tester Application. Upper Tester Application allows to trigger the IUT. Final verdicts are set on the return status of the external functions. Table 4 shows the list of external functions that the Test Adapter shall process.
- DLC TTCN-3 controls via external functions
  - the indication of sent and received data to and from the IUT.
  - the configuration of the Test Adapter
 Final verdicts are set on the return status of the external functions. Table 5 shows a selection of external functions. The Test Adapter shall implement all the external functions listed in WMx\_ExternalFns.ttcn.

**Table 1: Port macMsg**

<b>MAC management messages</b>
DsaBsIniReqMsg
DsaBsIniRspMsg
DsaAckMessage
DscReqMessage
DscRspMessage
DscAckMessage
DsdReqMessage
DsdRspMessage
RegReqMessage
RegRspMessage
RngReqMessage
RngRspMessage
SbcReqMessage
SbcRspMessage

**Table 2: Port macBcMsg**

<b>MAC management messages</b>
DIMapMessage
UIMapMessage
DcdMessage
UcdMessage

**Table 3: Port macPdu**

<b>MAC PDUs</b>
1 .. 10

**Table 4: External functions to trigger IUT action**

<b>ext function</b>	<b>Description</b>
xf_triggerBsDsaReq	BS (=IUT) is triggered to send a DSA-REQ
xf_triggerBsDsdReq	BS (=IUT) is triggered to send a DSD-REQ
xf_triggerBsEnableProfile	BS (=IUT) is trigger broadcast a new profile. The actual profile is overwritten by the new profile.
xf_triggerSsDataTransmission	This function triggers IUT (SS) to transmit data on established data cid/service flow.
xf_triggerBsDataTransmission	This function triggers IUT (BS) to transmit data on established data cid/service flow.
xf_dataReceivedOnlut	This function checks that data is received on the IUT on established data cid/service flow.

**Table 5: Selection of External functions to control test adapter**

<b>ext function</b>	<b>Description</b>
xf_enableProfile	This function starts the broadcast-emulation. Each time this external function is executed, the new profile overwrites the existing profile.
xf_disableProfile	This function disables the broadcasting of all the messages related to the indicated profile.
xf_triggerSsSimuDataTransmission	This function triggers TE (SsSimu) to transmit data on established data cid/service flow.
xf_setFsh	This function sets frame specific header of the message to be sent
xf_getFsh	This function gets frame specific header of the last received message

---

## 5 Untestable Test Purposes (TP)

This clause gives a list of TP, which are not implemented in the ATS due to the chosen ATM or other restrictions.

**Table 6: Untestable TP**

<b>Test Case Name</b>	<b>Reason</b>
void	

---

## 6 ATS conventions

The ATS conventions are intended to give a better understanding of the ATS but they also describe the conventions made for the development of the ATS. These conventions shall be considered during any later maintenance or further development of the ATS.

The ATS conventions contain two clauses, the naming conventions and the implementation conventions. The naming conventions describe the structure of the naming of all ATS elements. The implementation conventions describe the functional structure of the ATS.

To define the ATS, the guidelines of the document ETS 300 406 [3] was considered.

## 6.1 Testing conventions

### 6.1.1 Testing States

BS Null: The BS is switched on and sends broadcast messages

SS Null: The SS is switched on and is ready to receive broadcast messages

### 6.1.2 HiperMAN default values: Reception and transmission at ATS level

IEEE P802.16-2004 [2] lists many default TLV values. The spec says that devices SHOULD NOT transmit TLVs if the default value applies. However, this is NOT a requirement. Thus, one tested device may not transmit the default TLVs (or a subset of these default TLVs) while another may transmit all TLVs including the defaults. Including all the possible combinations of sent and received default TLVs in an ATS is problematic.

- Therefore, for ATS purposes, all TLVs are assumed to be sent and received at the ATS level.
- The Test Adapter will fill in the missing received TLVs with a TLV containing the default value and pass it up to the ATS.
- The Test Adapter may or may not transmit default TLVs received from the ATS to the IUT. This is a test equipment vendor decision.

### 6.1.3 Templates

- Separate templates are defined for use in sending and receiving operations.
- Template definitions should avoid using matching attributes such as "\*" or "?" for complete structured values, e.g. record or set of values.
- PIXIT parameter values are passed as parameters into templates.

### 6.1.4 Functions

The WMx ATS differentiates between external functions for which only the signature is specified and functions completely defined in the ATS. The completely defined functions are separated according to their use for SS or BS testing and preamble and postamble functions.

The SS and BS testing functions are grouped in a general configurations functions group and separate groups with functions used for testing different types of functionality.

Each type of function is implemented in a separate module, although there may be multiple modules for each function type. The following general rules apply:

- Functions use the *"runs on"* statement wherever this is possible.
- Each function provides a return value wherever this is possible. The return value used is the enumeration type "FncRetCode" defined in the WMx\_Types.ttcn file.

EXAMPLE: WMx\_Types.FncRetCode.

- The *stop* statement is used only for controlled test component shutdown.

## 6.2 Naming conventions

### 6.2.1 General guidelines

The naming convention is based on the following underlying principles:

- in most cases, identifiers should be prefixed with a short alphabetic string (specified in table 7) indicating the type of TTCN-3 element it represents;
- suffixes should not be used except in those specific cases identified in table 7;
- prefixes and suffixes should be separated from the body of the identifier with an underscore ("\_"):

EXAMPLES: `c_sixteen`, `t_wait_max`.

- only module names, data type names and module parameters should begin with an upper-case letter. All other names (i.e. the part of the identifier following the prefix) should begin with a lower-case letter:
- the start of second and subsequent words in an identifier should be indicated by capitalizing the first character. Underscores should not be used for this purpose:

EXAMPLE: `f_authenticateUser`.

Table 7 specifies the naming guidelines for each element of the TTCN-3 language indicating the recommended prefix, suffixes (if any) and capitalization.

**Table 7: IPv6 TTCN-3 naming convention**

Language element	Naming convention	Prefix	Suffix	Example	Notes
Module	Use upper-case initial letter	<i>none</i>	<i>none</i>	WMx_Templates	
TSS grouping	Use all upper-case letters	<i>none</i>	<i>none</i>	TP_RT_PS_TR	
Item group within a module	Use lower-case initial letter	<i>none</i>	<i>none</i>	messageGroup	
Data type	Use upper-case initial letter	<i>none</i>	<i>none</i>	SetupContents	
List type identifiers	Use upper-case initial letter	<i>none</i>	<i>none</i>	DIMapleList	
Message template	Use lower-case initial letter	m_	<i>none</i>	m_setupInit	
Message template with wildcard or matching expression	Use lower-case initial letters	mw_	<i>none</i>	mw_setupBasic	
Port instance	Use lower-case initial letter	<i>none</i>	<i>none</i>	signallingPort	
Test component ref	Use lower-case initial letter	<i>none</i>	<i>none</i>	userTerminal	
Signature	Use lower-case initial letter	s_	<i>none</i>	s_callSignature	
External function	Use lower-case initial letter	xf_	<i>none</i>	xf_calculateLength()	
Constant	Use lower-case initial letter	c_	<i>none</i>	c_maxRetransmission	
Function	Use lower-case initial letter	f_	<i>none</i>	f_authentication()	
Altstep	Use lower-case initial letter	a_	<i>none</i>	a_receiveSetup()	
Altstep (Default)	Use lower-case initial letter	d_	<i>none</i>	d_receiveOtherMessages()	
Variable	Use lower-case initial letter	v_	<i>none</i>	v_basicCid	
Variable, global to component	Use lower-case initial letter	g_	<i>none</i>	g_ssSimu.basicCid	
Timer	Use lower-case initial letter	t_	_min _max	t_wait t_auth_min	Note 1
Module parameters PICS values PIXIT values	Use all upper case letters	<i>none</i>	<i>none</i>	PIC_T7PXT_TNOAC	Note 2
External constant	Use lower-case initial letter	xc_	<i>none</i>	xc_macId	
Parameterization	Use lower-case initial letter	p_	<i>none</i>	p_macId	
Enumerated Value	Use lower-case initial letter	e_	<i>none</i>	e_synCpk	

NOTE 1: If a time window is needed, the suffixes "\_min" and "\_max" should be appended.

NOTE 2: In this case it is acceptable to use underscore as a word delimiter.

## 6.2.2 Test Case (TC) identifier

Table 8: TC naming convention

TC <st> <pg> <fg> <sg> <ini> <x> H<nnn>		
<st> = side type	BS	Base Station
	SS	Subscriber Station
<pg> = protocol group	CDM	Channel Descriptors and Maps
	RLC	Radio Link Control
	INI	Registration, IP Connectivity, and Parameter Transfer
	PKM	Privacy and Key Management
	DS	Dynamic Services
	BWA	Bandwidth Allocation and Polling
	RER	Reset and Re-registration
	CCC	Clock Comparison
	MAC	MAC PDU Construction
	PCS	Packet CS
<fg> = function group	MAP	Map and Frame Structure
	CD	Channel Descriptors
	CDC	Channel Descriptor Change
	IRNG	Initial Ranging
	PRNG	Periodic Ranging
	DBPC	Downlink Burst Profile Management
	SBC	Negotiate Basic Capabilities
	REG	Registration
	IPC	IP Connectivity
	AUTH	Authentication/Authorization
	TEK	Encryption Key Transfer
	SAM	Security Association Management
	EKS	Encryption and Key Scheduling
	DSA	Dynamic Service Addition
	DSC	Dynamic Service Change
	DSD	Dynamic Service Deletion
	REQ	Request/Grant
	MCP	Multicast Polling
	PACK	Packing
	FRAG	Fragmentation
	CAT	PDU Concatenation
	CRC	Cyclic Redundancy Check (CRC)
ARQ	ARQ	
PCU	Packet CS Usage	
CLS	Classification	
CDS	Classifier DSx Signalling	
PHS	Payload Header Suppression	
<sg> = subfunction group	INIT	Initialization
	OPN	Operation
	RLV	Relevance
	KU	Key Usage
	ENC	Encryption
	DEC	Decryption
<ini> = initiator of procedure or direction of flow	BsIni	Procedure is initiated by BS
	SsIni	Procedure is initiated by SS
	DL	Downlink
	UL	Uplink
<x> = type of testing	BV	Valid Behavior Tests
	BI	Invalid Syntax or Behavior Tests
	BO	Inopportune Behavior Tests
	TI	Timer and Counter Tests
<nnn> = sequential number	Hnnn	(H000, H001, ... )

EXAMPLE: TP identifier: TP/SS/RLC/IRNG/BV-H002  
TC identifier: TC\_SS\_RLC\_IRNG\_BV\_H002.

---

## Annex A (normative): Abstract Test Suite (ATS)

This ATS has been produced using the Testing and Test Control Notation (TTCN-3) according to ES 201 873-1 [8].

---

### A.1 The TTCN-3 Module

The TTCN-3 module corresponding to the ATS is contained in a compressed file named WMx\_ATS\_v107.zip contained in archive ts\_10238503v020102p0.zip which accompanies the present document.

---

## Annex B (normative): Partial PIXIT proforma for HiperMAN DLC

Notwithstanding the provisions of the copyright clause related to the text of the present document, ETSI grants that users of the present document may freely reproduce the Partial PIXIT proforma in this annex so that it can be used for its intended purposes and may further publish the completed Partial PIXIT.

The PIXIT Proforma is based on ISO/IEC 9646-6 [6]. Any needed additional information can be found in this international standard document.

---

### B.1 Identification summary

**Table B.1**

PIXIT Number:	
Test Laboratory Name:	
Date of Issue:	
Issued to:	

---

### B.2 ATS summary

**Table B.2**

Protocol Specification:	TS 102 178, TS 102 210 Or IEEE P802.16-2004, IEEE P802.16-2004/Cor1/D3
Protocol to be tested:	
ATS Specification:	RTS/BRAN-004T002-3R1
Abstract Test Method:	RTS/BRAN-004T002-3R1 clause 4

---

### B.3 Test laboratory

**Table B.3**

Test Laboratory Identification:	
Test Laboratory Manager:	
Means of Testing:	
SAP Address:	



## B.4 Client identification

**Table B.4**

Client Identification:	
Client Test manager:	
Test Facilities required:	

## B.5 SUT

**Table B.5**

Name:	
Version:	
SCS Number:	
Machine configuration:	
Operating System Identification:	
IUT Identification:	
PICS Reference for IUT:	
Limitations of the SUT:	
Environmental Conditions:	

## B.6 Protocol layer information

### B.6.1 Protocol identification

**Table B.6**

Name:	BRAN HM - DLC layer TS 102 178 BRAN HM - System Profiles TS 102 210 Or WiMAX – WirelessMAN OFDM IEEE P802.16-2004, IEEE P802.16-2004/Cor1/D3
Version:	
PICS References:	

### B.6.2 IUT information

For type and value definition consult the TTCN-3 module WMx\_Pixits.ttcn.

### B.6.2.1 Timers

**Table B.7: Timers**

Name	Comment
PXT_TDONE	Guard timer when MTC waits for all component done
PXT_TSYNC	Guard timer when MTC syncs the PTC
PXT_TRIGGER	Guard timer when MTC triggers the PTC
PXT_TAC	Guard timer to control a reaction
PXT_TNOAC	Guard timer to control a non-reaction
PXT_TWAIT	Wait for an implicit send
PXT_TDCD_INTERVAL	The time between transmission of DCD messages
PXT_TUCD_INTERVAL	The time between transmission of UCD messages
PXT_LOST_ULMAP_INTERVAL	The time between transmission of UL-MAP messages
PXT_LOST_DLMAP_INTERVAL	The time between transmission of DL-MAP messages

### B.6.2.2 Common Configuration

**Table B.8: Common Configuration**

Name	Comment
PXT_BS_SIMU_BS_ID	TE sends this BaseStationId in DL-MAP and DCD to SS(IUT)
PXT_BS_SIMU_UIUC	TE sends this UiucShort in UCD and UL-MAP to SS(IUT)

### B.6.2.3 DL-MAP message

**Table B.9: DL-Map message**

Name	Comment
PXT_MAX_NR_OF_DLMAP_RCV	Number of times that DL-MAP shall be received in order to assure periodic reception

### B.6.2.4 DCD message

**Table B.10: DCD message**

Name	Comment
PXT_MAX_NR_OF_DCD_RCV	Number of times that DCD shall be received in order to assure periodic reception

### B.6.2.5 UCD message

**Table B.11: UCD message**

Name	Comment
PXT_SS_SIMU_MAX_NR_OF_UCD_RCV	Number of times that UCD shall be received in order to assure periodic reception

## B.6.2.6 RNG-REQ message

**Table B.12: RNG-REQ message**

Name	Comment
PXT_SS_SIMU_MAC_ADDRESS	TE sends this MAC Address in RNG-REQ to BS (IUT)
PXT_SS_SIMU_MAC_VERSION	TE sends this MAC version in RNG-REQ to BS (IUT)
PXT_ROBUST_DIUC	TE sends this DIUC in RNG-REQ to BS (IUT). This Diuc shall indicate a robust profile
PXT_RNG_ANO	TE sends this Ranging Anomaly in RNG-REQ to BS (IUT)
PXT_SS_SIMU_POWER_LEVEL_ADJUST	TE sends this power level adjust in RNG-REQ to BS (IUT)
PXT_SS_SIMU_TIMING_ADJUST	TE sends this timing adjust in RNG-REQ to BS (IUT)
PXT_SS_SIMU_MAX_TX_POWER_RNG	max Tx Power level of SsSimu during ranging. If BS (IUT) keeps asking for more power than this Pixits indicates, then a RNG-REQ with anomalie c_ssAlreadyAtMaximumPower is sent

## B.6.2.7 RNG-RSP message

**Table B.13: RNG-RSP message**

Name	Comment
PXT_BASIC_CID	TE sends this Basic Cid in RNG-RSP to SS(IUT)
PXT_PRIM_CID	TE sends this Primary Cid in RNG-RSP to SS(IUT)
PXT_SEC_CID	TE sends this Secondary Cid in RNG-RSP to SS(IUT)
PXT_PHY_PARAMS_ADJUST_TOLERANCE	TE sends this adjustment tolerance in RNG-RSP to SS(IUT)
PXT_BS_SIMU_POWER_LEVEL_ADJUST	TE sends this PowerLevelAdjust in RNG-RSP to SS(IUT)
PXT_BS_SIMU_TIMING_ADJUST	TE sends this TimingAdjust in RNG-RSP to SS(IUT)
PXT_BS_SIMU_TOO_LARGE_TIMING_ADJUSTMENTS	TE sends this TimingAdjust which is too large in RNG-RSP to SS(IUT) ** This shall trigger the IUTs reaction with a RNG-REQ indication ** Ranging Anomaly "Sum of commanded timing adjustments is too large"

## B.6.2.8 SBC-REQ message

Table B.14: SBC-REQ message

Name	Comment
PXT_SS_SIMU_AUTHORIZATION_POLICY_SUPPORT	Indicates if the BS supports the IEEE 802.16 security policy. The TE sends this to the BS (IUT) in a SBC-REQ.
PXT_SS_SIMU_BANDWIDTH_ALLOCATION_SUPPORT	TE sends this Bandwidth Allocation Support in SBC-REQ to BS (IUT).
PXT_SS_SIMU_TTG	TE sends this Ttg in SBC-REQ to BS (IUT). transmit/receive transition gap TTG (in PSs).
PXT_SS_SIMU_RTG	TE sends this Rtg in SBC-REQ to BS (IUT). receive/transmit transition gap RTG (in PSs).
PXT_SS_SIMU_MAC_PDU_CONSTRUCTION_CAP	The BS (IUT) sends this to the TE in a SBC-RSP (provided this parameter is provided in the corresponding SBC-REQ).
PXT_SS_SIMU_MAX_TX_POWER	The TE sends this max power support in SBC-REQ to BS (IUT).
PXT_SS_SIMU_PKM_FLOW_CONTROL	The max number of outstanding PKM transactions supported by the TE. The TE sends this to the BS (IUT) in a SBC-REQ.
PXT_SS_SIMU_MAX_NR_SEC_ASSOCIATIONS	The max number of simultaneous security associations of the SS (TE). The TE sends this to the BS (IUT) in a SBC-REQ.
PXT_SS_SIMU_OFDM_FFT_SIZES	The FFT sizes supported by the SS (TE). The TE sends this to the BS (IUT) in a SBC-REQ.
PXT_SS_SIMU_OFDM_DEMODULATOR	The demodulator options supported by the SS (TE). The TE sends this to the BS (IUT) in a SBC-REQ.
PXT_SS_SIMU_OFDM_MODULATOR	The modulator options supported by the SS (TE). The TE sends this to the BS (IUT) in a SBC-REQ.
PXT_SS_SIMU_FOCUSED_CONTENTION	The Focused Contention supported by the SS (TE). The TE sends this to the BS (IUT) in a SBC-REQ.
PXT_SS_SIMU_TC_SPT	TC layer support by the SS (TE). The TE sends this to the BS (IUT) in a SBC-REQ.

## B.6.2.9 SBC-RSP message

Table B.15: SBC-RSP message

Name	Comment
PXT_SET_OPTIONS_IN_SBC_RSP_WITH_PIXITS	The TE sends in the SBC-RSP, in the case of [false] the received values from the SBC-REQ in the case of [true] new values
PXT_BS_SIMU_BANDWIDTH_ALLOCATION_SUPPORT	If PXT_SET_OPTIONS_IN_SBC_RSP_WITH_PIXITS, then TE sends this Bandwidth Allocation Support in SBC-RSP to SS(IUT).
PXT_BS_SIMU_SS_TTG	If PXT_SET_OPTIONS_IN_SBC_RSP_WITH_PIXITS, then TE sends this TTG in SBC-RSP to SS(IUT). The TTG is a gap between the downlink burst and the subsequent uplink burst. This gap is an integer number of PS durations and starts on a PS boundary.
PXT_BS_SIMU_SS_RTG	If PXT_SET_OPTIONS_IN_SBC_RSP_WITH_PIXITS, then TE sends this RTG in SBC-RSP to SS(IUT). The RTG is a gap between the uplink burst and the subsequent downlink burst. This gap is an integer number of PS durations and starts on a PS boundary.
PXT_BS_SIMU_MAX_TX_POWER	If PXT_SET_OPTIONS_IN_SBC_RSP_WITH_PIXITS, then TE sends this MAX_TX_POWER in SBC-RSP to SS(IUT). The maximum available power for BPSK, QPSK, 16-QAM and 64-QAM constellations. The maximum power parameters are reported in dBm and quantized in 0,5 dBm steps ranging from -64 dBm (encoded 0x00) to 63,5 dBm (encoded 0xFF).

Name	Comment
PXT_BS_SIMU_PDU_CONSTRUCT_CAP	If PXT_SET_OPTIONS_IN_SBC_RSP_WITH_PIXITS, then TE sends this PDU_CONSTRUCT_CAP in SBC-RSP to SS(IUT). PDU_CONSTRUCT_CAP: Capabilities for Construction and Transmission of MAC PDUs
PXT_BS_SIMU_PKM_FLOW_CTRL	If PXT_SET_OPTIONS_IN_SBC_RSP_WITH_PIXITS, then TE sends this PXT_BS_SIMU_PKM_FLOW_CTRL in SBC-RSP to SS(IUT).
PXT_BS_SIMU_AUTH_POLICY_SUPPORT	If PXT_SET_OPTIONS_IN_SBC_RSP_WITH_PIXITS, then TE sends this AUTH_POLICY_SUPPORT in SBC-RSP to SS(IUT).
PXT_BS_SIMU_MAX_NR_SEC_ASSOCIATIONS	If PXT_SET_OPTIONS_IN_SBC_RSP_WITH_PIXITS, then TE sends this MAX_NR_SEC_ASSOCIATIONS in SBC-RSP to SS(IUT).
PXT_BS_SIMU_CURRENT_TX_POWER	If PXT_SET_OPTIONS_IN_SBC_RSP_WITH_PIXITS, then TE sends this CURRENT_TX_POWER in SBC-RSP to SS(IUT). The transmitted power used for the burst which carried the message. The parameter is reported in dBm and is quantized in 0,5 dBm steps ranging from -64 dBm (encoded 0x00) to 63,5 dBm (encoded 0xFF).
PXT_BS_SIMU_OFDM_FFT_SIZES	If PXT_SET_OPTIONS_IN_SBC_RSP_WITH_PIXITS, then TE sends this OFDM_FFT_SIZES in SBC-RSP to SS(IUT). This field indicates the FFT sizes supported by the SS. For each FFT size, a bit value of 0 indicates "not supported" while 1 indicates "supported".
PXT_BS_SIMU_OFDM_DEMODULATOR	If PXT_SET_OPTIONS_IN_SBC_RSP_WITH_PIXITS, then TE sends this OFDM_DEMODULATOR in SBC-RSP to SS(IUT). This field indicates the different demodulator options supported by a WirelessMAN-OFDM PHY SS for downlink reception. A bit value of 0 indicates "not supported" while 1 indicates "supported".
PXT_BS_SIMU_OFDM_MODULATOR	If PXT_SET_OPTIONS_IN_SBC_RSP_WITH_PIXITS, then TE sends this OFDM_MODULATOR in SBC-RSP to SS(IUT). This field indicates the different modulator options supported by a WirelessMAN-OFDM PHY SS for uplink transmission. This field is not used for other PHY specifications. A bit value of 0 indicates "not supported" while 1 indicates "supported".
PXT_BS_SIMU_OFDM_TC_SUBLAYER_SPT	If PXT_SET_OPTIONS_IN_SBC_RSP_WITH_PIXITS, then TE sends this OFDM_TC_SUBLAYER_SPT in SBC-RSP to SS(IUT). This field indicates whether or not the SS supports the TC sublayer.0. A bit value of 0 indicates "not supported" while 1 indicates "supported".

### B.6.2.10 REG-REQ message

**Table B.16: REG-REQ message**

Name	Comment
PXT_SS_SIMU_UL_TRANSPORT_CID_SUPPORT	How many UL Transport Cids does SsSimu support? TE sends this NmbrUlTransportCidsSupported in REG-REQ to BS(IUT)
PXT_SS_SIMU_DL_TRANSPORT_CID_SUPPORT	How many DL Transport Cids does SsSimu support? TE sends this NmbrDlTransportCidsSupported in REG-REQ to BS(IUT)

## B.6.2.11 REG-RSP message

Table B.17: REG-RSP message

Name	Comment
PXT_SET_OPTIONS_IN_REG_RSP_WITH_PIXITS	TE sends in the REG-RSP, in the case of [false] the received values from the REG-REQ, in the case of [true] new values
PXT_BS_SIMU_UL_TRANSPORT_CIDS	TE sends this NmbrUITransportCidsSupportedTLV in REG-RSP to SS(IUT). This field shows the number of Uplink CIDs the SS can support. The minimum value is three for managed SSs and two for unmanaged SSs. An SS shall support a Basic CID, a Primary Management CID, and 0 or more Transport CIDs. A managed SS shall also support a Secondary Management CID
PXT_BS_SIMU_DL_TRANSPORT_CIDS	TE sends this NmbrDITransportCidsSupportedTLV in REG-RSP to SS(IUT). This field shows the number of Downlink transport CIDs the SS can support
PXT_BS_SIMU_SS_MNGT_SPT	TE sends this SsManagementSupport in REG-RSP to SS(IUT). This field indicates whether or not the SS is managed by standard-based IP messages over the secondary management connection
PXT_BS_SIMU_IP_MNGT_MODE	TE sends this IpManagementMode in REG-RSP to SS(IUT). The IP management mode parameter dictates whether the provider intends to manage the SS on an ongoing basis via IP-based mechanisms
PXT_BS_SIMU_IP_VERSION	TE sends this IpVersion in REG-RSP to SS(IUT). This field indicates the version of IP used on the Secondary Management Connection
PXT_BS_SIMU_CS_SPT	TE sends this CsSupport in REG-RSP to SS(IUT). This parameter indicates which classification/PHS options and SDU encapsulation the SS supports. By default, Packet, IPv4 and 802.3/Ethernet shall be supported
PXT_BS_SIMU_MAX_CLASSIFIER_NMBR	TE sends this MaxClassifiersNumber in REG-RSP to SS(IUT). This is the maximum number of admitted Classifiers that the SS supports
PXT_BS_SIMU_PHS_SPT	TE sends this PhsSupport in REG-RSP to SS(IUT) ** This parameter indicates the level of PHS support.
PXT_BS_SIMU_ARQ_SPT	TE sends this ArqSupport in REG-RSP to SS(IUT). This field indicates the availability of SS support for ARQ
PXT_BS_SIMU_DSX_FLOW_CONTROL	TE sends this DsxFlowControl in REG-RSP to SS(IUT). This field specifies the maximum number of concurrent DSA, DSC, or DSD transactions that may be outstanding
PXT_BS_SIMU_MCA_FLOW_CONTROL	TE sends this McaFlowControl in REG-RSP to SS(IUT). This field specifies the maximum number of concurrent MCA transactions that may be outstanding
PXT_BS_SIMU_PG_CID_SUPPORT	TE sends this MulticastPGCidSupport in REG-RSP to SS(IUT). This field indicates the maximum number of simultaneous Multicast Polling Groups the SS is capable of belonging to
PXT_BS_SIMU_VENDOR_ID	TE sends this VendorId in REG-RSP to SS(IUT)
PXT_BS_SIMU_VENDOR_INFO	TE sends this VendorInformation in REG-RSP to SS(IUT)

## B.6.2.12 Dynamic Service

Table B.18: Dynamic Service

Name	Comment
PXT_SFID	Service Flow Identifier
PXT_SFID_2	Service Flow Identifier for 2nd connection
PXT_TRAFFIC_RATE	Peak Traffic Rate in bits per second
PXT_PKT_CLASS_RULE_INDEX	Identifies a Packet Classifier Rule
PXT_PKT_CLASS_RULE_PRIORITY	Identifies a Packet Priority Rule
PXT_SCHEDULING_TYPE	TE sends this Scheduling Type in DSA-REQ to SS(IUT)
PXT_CS_LAYER	TE sends this Scheduling Type in DSA-REQ to SS(IUT)
PXT_TRANSPORT_CID	TE sends this Transport Cid in DSA-REQ to SS(IUT). Data will be sent on this Cid
PXT_TRANSPORT_CID_2	TE sends this 2nd Transport Cid in 2nd DSA-REQ to SS(IUT). Data will be sent on this Cid

## B.6.2.13 BWA

Table B.19: BWA

Name	Comment
PXT_BW_REQ	Bandwidth request in units of Bytes/second. The TE sends this to the BS (IUT) in a Bandwidth Request
PXT_BW_REQ_TYPE	Bandwidth request type. Either aggregate or incremental. The TE sends this to the BS (IUT) in a Bandwidth Request

## B.6.2.14 Test adapter

Table B.20: Test adapter

Name	Comment
PXT_FRAME_SPECIFIC_HEADER_LENGTH	What is the FrameSpecificHeaderLength ?
PXT_DIRECTION	UL or DL direction?
PXT_SUBFRAME_CONTROL	What kind of subframe control?
PXT_BURST_CONTROL	What kind of burst control?
PXT_SUBFRAME_NO	What subframe number?
PXT_BURST_NO	Which burst number ?
PXT_PDU_NO	Which PDU number?
PXT_TRANSMITTED_POWER	Transmitted Power
PXT_CENTER_FREQUENCY	Center Frequency in kHz
PXT_TIMING	What kind of timing?
PXT_LOW_POWER_LEVEL	What is the lowest power level on which TE can send and that IUT (BS) will not accept ? ** In Units of???
PXT_DEFAULT_POWER_LEVEL	What is the default power level on which TE can send and that IUT (BS) will accept ? ** In Units of???

## Annex C (normative): PCTR Proforma for HiperMAN DLC

Notwithstanding the provisions of the copyright clause related to the text of the present document, ETSI grants that users of the present document may freely reproduce the PCTR proforma in this annex so that it can be used for its intended purposes and may further publish the completed PCTR.

The PCTR proforma is based on ISO/IEC 9646-6 [6]. Any needed additional information can be found in this International standard document.

### C.1 Identification summary

#### C.1.1 Protocol conformance test report

**Table C.1**

PCTR Number:	
PCTR Date:	
Corresponding SCTR Number:	
Corresponding SCTR Date:	
Test Laboratory Identification:	
Test Laboratory Manager:	
Signature:	

#### C.1.2 IUT identification

**Table C.2**

Name:	
Version:	
Protocol specification:	
PICS:	
Previous PCTR if any:	

#### C.1.3 Testing environment

**Table C.3**

PIXIT Number:	
ATS Specification:	
Abstract Test Method:	RTS/BRAN-004T002-3R1 clause 4
Means of Testing identification:	
Date of testing:	
Conformance Log reference(s):	
Retention Date for Log reference(s):	



### C.1.4 Limits and reservation

Additional information relevant to the technical contents or further use of the test report, or the rights and obligations of the test laboratory and the client, may be given here. Such information may include restriction on the publication of the report.

.....  
.....  
.....  
.....  
.....

### C.1.5 Comments

Additional comments may be given by either the client or the test laboratory on any of the contents of the PCTR, for example, to note disagreement between the two parties.

.....  
.....  
.....  
.....  
.....

---

## C.2 IUT Conformance status

This IUT has or has not been shown by conformance assessment to be non-conforming to the specified protocol specification.

*Strike the appropriate words in this sentence. If the PICS for this IUT is consistent with the static conformance requirements (as specified in clause C.3 in this report) and there are no "FAIL" verdicts to be recorded (in clause C.6 in this report) strike the words "has or", otherwise strike the words "or has not".*

---

## C.3 Static conformance summary

The PICS for this IUT is or is not consistent with the static conformance requirements in the specified protocol.

*Strike the appropriate words in this sentence.*

---

## C.4 Dynamic conformance summary

The test campaign did or did not reveal errors in the IUT.

*Strike the appropriate words in this sentence. If there are no "FAIL" verdicts to be recorded (in clause C.6 of this report) strike the words "did or" otherwise strike the words "or did not".*

Summary of the results of groups of test:

.....  
.....  
.....  
.....  
.....  
.....  
.....  
.....  
.....  
.....

## C.5 Static conformance review report

If clause C.3 indicates non-conformance, this clause itemises the mismatches between the PICS and the static conformance requirements of the specified protocol specification.

.....

.....

.....

.....

.....

.....

.....

.....

.....

.....

## C.6 Test campaign report

**Table C.4: SS test cases**

ATS Reference	Selected?	Run?	Verdict	Observations (Reference to any observations made in clause C.7)
TC_SS_CDM_MAP_INIT_BV_H000	Yes/No	Yes/No		
TC_SS_CDM_MAP_INIT_BV_H002	Yes/No	Yes/No		
TC_SS_CDM_MAP_RLV_BV_H000	Yes/No	Yes/No		
TC_SS_CDM_MAP_RLV_BV_H001	Yes/No	Yes/No		
TC_SS_CDM_MAP_OPN_BV_H000	Yes/No	Yes/No		
TC_SS_CDM_CD_BV_H000	Yes/No	Yes/No		
TC_SS_CDM_CD_BV_H001	Yes/No	Yes/No		
TC_SS_RLC_IRNG_BV_H000	Yes/No	Yes/No		
TC_SS_RLC_IRNG_BV_H001	Yes/No	Yes/No		
TC_SS_RLC_IRNG_BV_H015	Yes/No	Yes/No		
TC_SS_RLC_IRNG_BV_H100	Yes/No	Yes/No		
TC_SS_RLC_IRNG_BV_H101	Yes/No	Yes/No		
TC_SS_RLC_IRNG_BV_H102	Yes/No	Yes/No		
TC_SS_RLC_IRNG_BV_H002	Yes/No	Yes/No		
TC_SS_RLC_SBC_BV_H000	Yes/No	Yes/No		
TC_SS_RLC_SBC_BV_H001	Yes/No	Yes/No		
TC_SS_INI_REG_BV_H000	Yes/No	Yes/No		
TC_SS_DS_DSA_BV_H000	Yes/No	Yes/No		
TC_SS_DS_DSA_BV_H002	Yes/No	Yes/No		
TC_SS_DS_DSA_BV_H001	Yes/No	Yes/No		
TC_SS_DS_DSA_BV_H003	Yes/No	Yes/No		
TC_SS_DS_DSD_BV_H000	Yes/No	Yes/No		
TC_SS_DS_DSD_BV_H001	Yes/No	Yes/No		
TC_SS_BWA_REQ_BV_H000	Yes/No	Yes/No		
TC_SS_BWA_REQ_BV_H001	Yes/No	Yes/No		
TC_SS_BWA_REQ_BV_H002	Yes/No	Yes/No		
TC_SS_BWA_REQ_BV_H003	Yes/No	Yes/No		
TC_SS_BWA_REQ_BV_H004	Yes/No	Yes/No		

Table C.5: BS test cases

ATS Reference	Selected?	Run?	Verdict	Observations (Reference to any observations made in clause C.7)
TC_BS_CDM_MAP_BV_H000	Yes/No	Yes/No		
TC_BS_CDM_MAP_BV_H001	Yes/No	Yes/No		
TC_BS_CDM_MAP_BV_H002	Yes/No	Yes/No		
TC_BS_CDM_CD_BV_H000	Yes/No	Yes/No		
TC_BS_CDM_CD_BV_H001	Yes/No	Yes/No		
TC_BS_CDM_CD_BV_H002	Yes/No	Yes/No		
TC_BS_RLC_IRNG_BV_H000	Yes/No	Yes/No		
TC_BS_RLC_IRNG_BV_H001	Yes/No	Yes/No		
TC_BS_RLC_IRNG_BV_H002	Yes/No	Yes/No		
TC_BS_RLC_IRNG_BV_H009	Yes/No	Yes/No		
TC_BS_RLC_IRNG_BV_H010	Yes/No	Yes/No		
TC_BS_RLC_IRNG_BV_H011	Yes/No	Yes/No		
TC_BS_RLC_IRNG_TI_H000	Yes/No	Yes/No		
TC_BS_RLC_IRNG_TI_H001	Yes/No	Yes/No		
TC_BS_RLC_PRNG_BV_H002	Yes/No	Yes/No		
TC_BS_RLC_SBC_BV_H000	Yes/No	Yes/No		
TC_BS_DS_DSA_BV_H000	Yes/No	Yes/No		
TC_BS_DS_DSA_BV_H003	Yes/No	Yes/No		
TC_BS_DS_DSA_BV_H001	Yes/No	Yes/No		
TC_BS_DS_DSA_BV_H004	Yes/No	Yes/No		
TC_BS_DS_DSD_BV_H000	Yes/No	Yes/No		
TC_BS_DS_DSD_BV_H001	Yes/No	Yes/No		
TC_BS_BWA_REQ_BV_H000	Yes/No	Yes/No		
TC_BS_BWA_REQ_BV_H001	Yes/No	Yes/No		
TC_BS_BWA_REQ_BV_H002	Yes/No	Yes/No		
TC_BS_BWA_REQ_BV_H003	Yes/No	Yes/No		
TC_BS_BWA_REQ_BV_H004	Yes/No	Yes/No		

---

## C.7 Observations

Additional information relevant to the technical content of the PCTR is given here.

.....

.....

.....

.....

.....

.....

.....

.....

.....

.....

.....

.....

---

## Annex D (informative): Bibliography

IETF RFC 2131: "Dynamic Host Configuration Protocol".

IETF RFC 868: "Time Protocol".

IETF RFC 1123: "Requirements for Internet Hosts - Application and Support".

IETF RFC 2349: "TFTP Timeout Interval and Transfer Size Options".

ISO/IEC 9646-3/ITU-T Recommendation X.292: "Information technology - Open Systems Interconnection - Conformance testing methodology and framework - Part 3: The Tree and Tabular Combined Notation (TTCN)".

---

## History

<b>Document history</b>		
V2.1.1	December 2005	Publication
V2.1.2	March 2006	Publication