

ETSI TS 102 361-4 V1.6.1 (2014-06)



Technical Specification

**Electromagnetic compatibility  
and Radio spectrum Matters (ERM);  
Digital Mobile Radio (DMR) Systems;  
Part 4: DMR trunking protocol**

---

Reference

RTS/ERM-TGDMM-315

---

Keywords

data, digital, MS, radio, signalling, trunking

**ETSI**

650 Route des Lucioles  
F-06921 Sophia Antipolis Cedex - FRANCE

Tel.: +33 4 92 94 42 00 Fax: +33 4 93 65 47 16

Siret N° 348 623 562 00017 - NAF 742 C  
Association à but non lucratif enregistrée à la  
Sous-Préfecture de Grasse (06) N° 7803/88

---

**Important notice**

The present document can be downloaded from:

<http://www.etsi.org>

The present document may be made available in electronic versions and/or in print. The content of any electronic and/or print versions of the present document shall not be modified without the prior written authorization of ETSI. In case of any existing or perceived difference in contents between such versions and/or in print, the only prevailing document is the print of the Portable Document Format (PDF) version kept on a specific network drive within ETSI Secretariat.

Users of the present document should be aware that the document may be subject to revision or change of status. Information on the current status of this and other ETSI documents is available at

<http://portal.etsi.org/tb/status/status.asp>

If you find errors in the present document, please send your comment to one of the following services:

[http://portal.etsi.org/chaicor/ETSI\\_support.asp](http://portal.etsi.org/chaicor/ETSI_support.asp)

---

**Copyright Notification**

No part may be reproduced or utilized in any form or by any means, electronic or mechanical, including photocopying and microfilm except as authorized by written permission of ETSI.

The content of the PDF version shall not be modified without the written authorization of ETSI.

The copyright and the foregoing restriction extend to reproduction in all media.

© European Telecommunications Standards Institute 2014.

All rights reserved.

**DECT™**, **PLUGTESTS™**, **UMTS™** and the ETSI logo are Trade Marks of ETSI registered for the benefit of its Members. **3GPP™** and **LTE™** are Trade Marks of ETSI registered for the benefit of its Members and of the 3GPP Organizational Partners.

**GSM®** and the GSM logo are Trade Marks registered and owned by the GSM Association.

# Contents

Intellectual Property Rights .....	10
Foreword.....	10
1 Scope .....	11
2 References .....	11
2.1 Normative references .....	11
2.2 Informative references.....	12
3 Definitions, symbols and abbreviations .....	12
3.1 Definitions.....	12
3.2 Symbols.....	16
3.3 Abbreviations .....	16
4 Overview .....	18
4.1 Protocol architecture.....	19
4.1.1 Air Interface Physical Layer (layer 1).....	20
4.1.2 Air Interface Data Link Layer (layer 2).....	20
4.1.3 Air Interface Call Control Layer (layer 3) .....	21
4.2 Services and Facilities .....	21
4.3 Device Addresses .....	23
4.3.1 MS Addresses .....	23
4.3.2 Services and Gateway Addresses.....	23
4.4 Conventional/Trunked Systems.....	23
4.5 MS Location.....	23
4.6 Tier III Services.....	24
4.6.1 MS initiating calls.....	24
4.6.2 MS receiving calls .....	24
4.6.2.1 MS receiving individual calls.....	25
4.6.2.1.1 Off Air Call Set-Up (OACSU).....	25
4.6.2.1.2 Full Off Air Call Set-Up (FOACSU).....	25
4.6.2.2 MS receiving calls to talkgroups .....	25
4.6.2.3 MS receiving calls to All_MS.....	25
4.7 Physical Link Organization .....	25
4.7.1 Radio Frequency Allocation .....	25
4.7.2 Colour Code (CC).....	25
4.8 DMR TDMA burst and channel structure .....	26
4.9 Introduction to the TS Structure .....	27
4.9.1 An individual voice call example .....	27
4.9.1.1 Individual Call using OACSU.....	27
4.9.1.2 Individual Call using FOACSU .....	28
4.9.2 A talkgroup call example .....	29
4.10 Network architecture .....	29
4.10.1 Network functions .....	30
4.10.1.1 Establishing service.....	30
4.10.1.2 Network Identifier.....	30
4.10.2 MS Location by Registration.....	30
4.11 Trunking methods.....	30
4.11.1 Message trunking.....	30
4.11.2 Transmission trunking .....	31
4.11.3 Quasi-Transmission trunking.....	31
5 Trunking Control Channel Formats .....	31
5.1 The use of the CACH .....	32
5.1.1 SYS_Parms - System Identity Code Subset.....	32
5.1.2 SYS_Parms - Reg .....	32
5.1.3 SYS_Parms - Common_Slot_Counter.....	32
5.2 Tier III signalling.....	33

5.3	Modes of control channel .....	33
5.3.1	Dedicated TSCC .....	33
5.3.2	Non-Dedicated TSCC .....	33
5.3.3	Operation in shared spectrum .....	33
5.4	CSBK/MBC/UDT Block Structure .....	34
5.4.1	CSBK/MBC/UDT PDUs on the TSCC outbound channel .....	34
5.4.2	CSBK/MBC/UDT PDUs on the TSCC inbound channel .....	35
5.4.3	CSBK/MBC PDUs on the Payload Channel Outbound channel .....	36
5.4.4	CSBK PDUs on the Payload Channel Inbound channel .....	37
6	Trunking Procedures .....	37
6.1	Basic Structure .....	37
6.1.1	Channel Structure .....	37
6.1.1.1	Fully Regulated Structure .....	37
6.1.1.2	Shared Channel Unregulated Structure .....	38
6.1.2	Physical Channel Addressing .....	38
6.1.3	Sub-Division of the MS population .....	38
6.2	Random Access Procedures .....	40
6.2.1	The Random Access Principle .....	40
6.2.1.1	Random Access Control .....	40
6.2.1.1.1	Sub dividing the MS population .....	40
6.2.1.1.2	Checking the Service-Function .....	41
6.2.1.1.3	Withdrawing slots from Random-Access .....	41
6.2.1.1.4	TSCC responses to Random Access attempts .....	42
6.2.1.1.5	Noting the response delay .....	42
6.2.1.1.6	Random Backoff .....	43
6.2.1.1.7	Retry decision and time-outs .....	44
6.2.1.1.8	Random Access (non-emergency) SDL for a MS as defined in clause 6.2 .....	45
6.2.1.1.9	Random Access (emergency) SDL for a MS as defined in clause 6.2 .....	48
6.2.1.2	Action after receiving an acknowledgement .....	50
6.2.1.3	MS Arriving on a Control Channel .....	51
6.3	Control Channel Acquisition and Retention .....	51
6.3.1	MS Parameter Volatility .....	52
6.3.2	Control Channel Acquisition Procedures .....	52
6.3.2.1	Entry into TSCC Acquisition Procedures .....	53
6.3.2.2	Identifying a Candidate Control Channel .....	53
6.3.2.2.1	Checking the System Identity Code .....	53
6.3.2.2.2	TSCC Authorization Procedure .....	56
6.3.2.2.3	Checking the SYS_AREA information element .....	57
6.3.2.3	Confirmation - Monitoring the TSCC outbound channel signal quality .....	58
6.3.3	MS Leaving a Control Channel .....	58
6.3.3.1	Reasons for Leaving a Control Channel when active but idle .....	58
6.3.3.2	Leaving a Control Channel Whilst Waiting for Signalling .....	59
6.4	Registration, Power Save, and Authentication Procedures .....	59
6.4.1	Registration .....	60
6.4.1.1	Introduction .....	60
6.4.1.2	The Principle .....	60
6.4.2	MS Parameter Volatility .....	61
6.4.3	Action on confirmation of a TSCC .....	61
6.4.4	Registration Procedures .....	62
6.4.4.1	Registration by Random Access .....	62
6.4.4.1.1	Intermediate Acknowledgement .....	64
6.4.4.1.2	Registration accepted .....	64
6.4.4.1.3	Registration Refused .....	64
6.4.4.1.4	Registration Denied .....	64
6.4.4.1.5	Challenge and Response Authentication .....	64
6.4.4.1.6	Registration Attempt Times Out .....	65
6.4.4.1.7	Registration Demand Received During Random Access Registration .....	65
6.4.4.1.8	No answer response Received after the maximum number of random access attempts .....	65
6.4.4.1.9	Registration Action on Switch-on or equivalent .....	65
6.4.4.1.10	Registration scenario MSC .....	66
6.4.4.1.11	Registration with MS authentication .....	67

6.4.4.1.12	Acceptance of user initiated service requests .....	68
6.4.5	Mass re-registration .....	69
6.4.5.1	Procedure for MS on receipt of Mass Re-registration Broadcast .....	69
6.4.6	De-registration .....	70
6.4.7	Power Save .....	70
6.4.7.1	Overview .....	70
6.4.7.2	Power Save Procedures .....	71
6.4.7.2.1	Basic Power Save Procedures.....	71
6.4.8	Authentication Procedures .....	72
6.4.8.1	Key Management .....	73
6.4.8.2	Authentication Procedures for the TSCC to authenticate a MS .....	73
6.4.8.3	Authentication Procedures for the MS .....	74
6.4.9	MS Stun/Revive.....	74
6.4.9.1	MS Stun/Revive without authentication.....	74
6.4.9.1.1	Stun / Revive procedures for the TSCC .....	74
6.4.9.1.2	Stun / Revive procedures for the MS.....	75
6.4.9.2	MS Stun/Revive with authentication.....	75
6.4.9.2.1	Stun / Revive procedures with authentication for the TSCC .....	75
6.4.9.2.2	Stun / Revive procedures with authentication for the MS .....	76
6.4.10	MS Kill .....	77
6.4.10.1	Kill procedures with authentication for the TSCC .....	77
6.4.10.2	Kill procedures with authentication for the MS .....	78
6.4.11	IP Connection Advice.....	79
6.4.11.1	IP Connection Advice procedures for the MS.....	79
6.4.11.1.1	Registration Attempt Times Out.....	79
6.4.11.1.2	No answer response received after the maximum number of random access attempts .....	80
6.4.11.1.3	MS response to C_AHOY inviting the MS to send an IP address.....	80
6.4.11.1.4	Final acknowledgment to IP connection advice received by the calling MS .....	80
6.4.11.2	IP Connection Advice procedures for the TSCC .....	80
6.4.12	Unsolicited MS Radio Check.....	80
6.4.13	Supplementary_User Data Service .....	81
6.4.14	MS Power Control and Transmitter Pre-emption Control .....	82
6.4.14.1	Reverse Channel .....	82
6.4.14.2	Procedures for Power Control.....	83
6.4.14.3	Procedures for Transmission Pre-emption Control .....	83
6.5	Unified Data Transport Mechanism .....	83
6.5.1	Format of the appended data.....	86
6.5.1.1	UDT Block Structure .....	86
6.5.1.2	UDT Content for Services Carried on the Outbound channel.....	87
6.5.1.3	UDT Mechanism for the Inbound channel.....	88
6.6	Call procedures.....	89
6.6.1	Procedures common to Voice calls and Packet Data Calls .....	90
6.6.1.1	MS Availability Checks .....	90
6.6.1.1.1	Availability of calling MS .....	90
6.6.1.1.2	Availability of called party as part of a call.....	91
6.6.1.1.3	General MS radio check .....	91
6.6.1.2	Call Cancellation.....	91
6.6.1.2.1	Cancelling a OACSU Call .....	91
6.6.1.2.2	Cancelling a FOACSU Call.....	91
6.6.1.3	Acknowledgements sent to calling MS .....	92
6.6.1.4	Called Party Answering Mechanism.....	92
6.6.1.4.1	TSCC response to the Call Answer Random Access.....	93
6.6.1.4.2	Call Party Answer behaviour for the MS.....	93
6.6.1.5	Maintenance of call progress waiting timers.....	94
6.6.1.5.1	Call waiting timer for the calling MS .....	94
6.6.1.5.2	Call waiting timer for the called MS .....	94
6.6.1.6	Payload Channel Assignment.....	95
6.6.1.7	Calls to ALLMSID, ALLMSIDL and ALLMSIDZ.....	95
6.6.2	Voice Call Procedures .....	96
6.6.2.1	Voice Call Procedures for the TSCC .....	97
6.6.2.1.1	TSCC Response to single-part voice call set-up.....	97
6.6.2.1.2	TSCC Response to multi-part voice call set-up.....	97

6.6.2.1.3	Acknowledgements sent by the TSCC to the calling MS (voice).....	98
6.6.2.1.4	Voice Radio Check.....	98
6.6.2.1.5	Availability Check for Voice Calls connected through Gateways .....	99
6.6.2.2	Voice Call Procedures for MS .....	99
6.6.2.2.1	Initiating a single-part voice call service .....	100
6.6.2.2.2	Response to the single-part voice service request.....	100
6.6.2.2.3	Response to the multi-part voice service request.....	101
6.6.2.2.4	Acknowledgements received by the calling MS (voice) .....	101
6.6.2.2.5	Availability Check to the called party (voice).....	102
6.6.2.2.6	Payload Channel Allocation .....	102
6.6.2.2.7	Calling MS in single part voice call setup SDL.....	103
6.6.2.2.8	Call set-up MSC that also transfers supplementary_user data.....	105
6.6.2.3	Timing requirements for the allocation of a Payload Channel .....	105
6.6.2.3.1	TSCC and Payload channel are time aligned.....	106
6.6.2.3.2	TSCC and Payload channel are not time aligned.....	106
6.6.2.4	Procedures for the Voice Payload Channel .....	106
6.6.2.4.1	TS Procedures for the Voice Payload Channel.....	107
6.6.2.4.2	MS Procedures for the Voice Payload Channel.....	111
6.6.3	Packet Data Call Procedures .....	113
6.6.3.1	Packet Data Call Procedures for the TSCC.....	113
6.6.3.1.1	TSCC Response to single-part packet call set-up.....	113
6.6.3.1.2	TSCC Response to multi-part packet call setup .....	114
6.6.3.1.3	Acknowledgements sent on the TSCC to the calling MS (packet).....	114
6.6.3.1.4	Radio Check for packet .....	114
6.6.3.1.5	Availability Check for Packet Calls connected through Gateways .....	115
6.6.3.2	Packet Data Call Procedures for MS.....	115
6.6.3.2.1	Initiating a single-part packet data call service.....	116
6.6.3.2.2	Response to the single-part packet service request.....	116
6.6.3.2.3	Response to the multi-part packet data service request .....	116
6.6.3.2.4	Acknowledgements received by the calling MS (packet data).....	117
6.6.3.2.5	Availability Check to the called MS (packet data) .....	117
6.6.3.2.6	Payload Channel Allocation .....	117
6.6.3.3	Procedures for the Packet Data Payload Channel .....	118
6.6.3.3.1	TS Procedures for the Packet Data Payload Channel .....	118
6.6.3.3.2	MS Procedures for the Packet Data Payload Channel .....	120
6.6.4	Short Data Message Procedure .....	122
6.6.4.1	Short Data Procedures for the TSCC .....	123
6.6.4.1.1	TSCC Response to a call to an individual MS or talkgroup .....	123
6.6.4.1.2	TSCC Response to a call to an extended_address destination.....	124
6.6.4.1.3	Availability Check to the called MS (UDT short data) .....	124
6.6.4.1.4	Final acknowledgement to the calling party .....	125
6.6.4.2	Short Data Message procedures for MS.....	125
6.6.4.3	Initiating a Short Data Message service .....	126
6.6.4.4	Response to a random access UDT short data message .....	126
6.6.4.5	Acknowledgements received by the calling MS .....	126
6.6.4.6	Timeout waiting for further signalling .....	126
6.6.4.7	MS receiving a UDT short data message .....	127
6.6.4.8	Short Data Message procedure MSC .....	127
6.6.5	Short Data Polling Service.....	128
6.6.5.1	Short Data Polling Procedures for the TSCC .....	129
6.6.5.1.1	TSCC Response to a poll request from an MS .....	129
6.6.5.1.2	Availability Check to the called MS (UDT short data poll) .....	129
6.6.5.1.3	Delivery of the polled data to the calling party .....	129
6.6.5.1.4	Final acknowledgement by the calling party to the TSCC .....	130
6.6.5.1.5	Short Data Polling procedures from a TSCC gateway .....	130
6.6.5.2	Short Data Polling Message procedures for MS .....	130
6.6.5.3	Initiating a Short Data Polling service .....	130
6.6.5.4	Response to a random access UDT short data polling message.....	130
6.6.5.5	Final Acknowledgement transmitted by the calling MS .....	131
6.6.5.6	Timeout waiting for further signalling .....	131
6.6.5.7	MS receiving a C_AHOY poll for a short polling message .....	131
6.6.6	Status Call Service.....	131

6.6.6.1	Status Service Delivery Procedure .....	131
6.6.6.1.1	Status Service Delivery Procedures for the TSCC .....	132
6.6.6.1.2	Status Service Delivery Procedures for MS .....	133
6.6.6.2	Status Polling Service Procedure .....	136
6.6.6.2.1	Status Service Polling Procedures for the TSCC.....	136
6.6.6.2.2	Status Polling Service Procedures for MS .....	137
6.6.7	Call Diversion.....	139
6.6.7.1	Call Diversion Service .....	139
6.6.7.1.1	TSCC Procedures for the Call Diversion Service.....	140
6.6.7.1.2	MS Procedures for the Call Diversion Service .....	141
6.6.7.2	Diverting Calls .....	144
6.7	System Management Procedures.....	145
6.7.1	Network System Announcements.....	145
6.7.1.1	Announce/Withdraw TSCC .....	145
6.7.1.2	Specify Call Timer parameters.....	146
6.7.1.3	Vote now advice.....	146
6.7.1.4	Announce Local Time.....	147
6.7.1.5	Mass Registration.....	147
6.7.1.6	Announce a logical physical channel relationship .....	147
6.7.1.7	Adjacent Site Information .....	147
7	PDU description .....	148
7.1	Layer 3 PDUs .....	148
7.1.1	Control Signalling Block (CSBK/MBC/UDT) PDUs.....	148
7.1.1.1	TSCC Outbound channel CSBK/MBC/UDT .....	153
7.1.1.1.1	Channel Grant CSBK/MBC PDU .....	153
7.1.1.1.2	Channel Grant Absolute Parameters (CG_AP) appended MBC PDU .....	159
7.1.1.1.3	Move TSCC (C_MOVE) CSBK/MBC PDU.....	160
7.1.1.1.4	Aloha (C_ALOHA) CSBK PDU.....	161
7.1.1.1.5	Announcements (C_BCAST) CSBK/MBC PDU.....	162
7.1.1.1.6	Ahoy (AHOY) CSBK PDU.....	164
7.1.1.1.7	Acknowledgement C_ACKD) TSCC Response CSBK PDU .....	165
7.1.1.1.8	Unified Data Transport Outbound Header (C_UDTHD) UDT PDU .....	166
7.1.1.2	TSCC Inbound channel CSBKs/UDTs transmitted by MS.....	167
7.1.1.2.1	Random Access Request (C_RAND) PDU .....	167
7.1.1.2.2	C_Ackvitation (C_ACKVIT) CSBK PDU .....	168
7.1.1.2.3	C_Acknowledge (C_ACKU) MS Response CSBK PDU .....	169
7.1.1.2.4	Unified Data Transport Inbound channel Header (C_UDTHU) UDT PDU.....	170
7.1.1.3	Outbound channel CSBKs transmitted on a Payload Channel by a TS .....	171
7.1.1.3.1	Channel Grant (P_GRANT) CSBK/MBC PDU .....	171
7.1.1.3.2	Clear (P_CLEAR) CSBK PDU .....	172
7.1.1.3.3	Protect (P_PROTECT) CSBK PDU.....	173
7.1.1.3.4	Ahoy (P_AHOY) CSBK PDU .....	174
7.1.1.3.5	P_Acknowledgement response.....	174
7.1.1.4	Inbound channel CSBKs transmitted on a Payload Channel by MS(s).....	175
7.1.1.4.1	Random Access Request PDU .....	175
7.1.1.4.2	P_ACK Acknowledgements.....	175
7.1.1.4.3	P_MAINT Maintenance PDUs.....	176
7.1.2	Short Link Control PDUs .....	176
7.1.2.1	System Parameters .....	176
7.2	Layer 3 information element coding .....	177
7.2.1	Mask .....	177
7.2.2	Service Function .....	177
7.2.3	NRand_Wait .....	178
7.2.4	Reg.....	178
7.2.5	Backoff .....	178
7.2.6	System Identity Code.....	179
7.2.7	Response_Info .....	179
7.2.8	Reason .....	179
7.2.8.1	Acknowledgements C_ACK.....	179
7.2.8.2	Acknowledgements C_NACK.....	180
7.2.9	Digits .....	183

7.2.10	Active_Connection .....	184
7.2.11	Packet Mode .....	184
7.2.12	Service_Kind .....	184
7.2.12.1	Service_Kind_Flag.....	186
7.2.12.2	UDT_Option_Flag .....	187
7.2.13	Service_Options.....	187
7.2.13.1	Service_Options for a Voice Service Request.....	187
7.2.13.2	Service_Options for a Packet Data Service Request.....	188
7.2.13.3	Service_Options for a Call Diversion Service Request.....	188
7.2.13.4	Service_Options for a Registration Service Request.....	189
7.2.13.5	Service_Options for an Include Call Service Request .....	189
7.2.13.6	Service_Options for a Status Transport Request.....	189
7.2.13.7	Service_Options for the Short Data Service.....	190
7.2.13.8	Service_Options for the Supplementary Data Service .....	190
7.2.13.9	Service_Options for a Short Data Polling Request .....	190
7.2.14	Service_Options_Mirror .....	190
7.2.14.1	Service_Options_Mirror for MS Authentication.....	191
7.2.14.2	Service_Options_Mirror for MS Stun/Revive.....	191
7.2.14.3	Service_Options_Mirror for MS Kill .....	191
7.2.15	Proxy Flag.....	191
7.2.16	POL_FMT.....	192
7.2.17	Appended_Block .....	192
7.2.18	Opcode.....	193
7.2.19	Announcement type .....	193
7.2.19.1	Announce/Withdraw TSCC (Ann-WD_TSCC) .....	194
7.2.19.2	Specify Call Timer Parameters (CallTimer_Parms).....	194
7.2.19.3	Vote Now Advice (Vote_Now).....	194
7.2.19.4	Broadcast Local Time (Local_Time) .....	195
7.2.19.4.1	Broadcast Local Time - Month (B_MONTH).....	195
7.2.19.4.2	Broadcast Local Time - Day of Week (DAYSOF_WEEK) .....	196
7.2.19.5	Broadcast Mass Registration (MassReg) .....	196
7.2.19.5.1	Reg_Window .....	196
7.2.19.6	Broadcast Adjacent Site information .....	197
7.2.19.7	CdefParms absolute frequency relationship .....	197
7.2.20	Individual/Group (IG).....	197
7.2.21	Protect_Kind .....	198
7.2.22	Maint_Kind.....	198
7.2.23	Response expected (A) .....	198
7.2.24	Format.....	199
7.2.25	Service Access Point (SAP).....	199
7.2.26	Pad Nibble (PN).....	200
7.2.27	UDT Format.....	200
7.2.28	Offset .....	200
7.2.29	Protect Flag (PF).....	201
7.2.30	Privacy .....	201
7.2.31	STATUS .....	201
7.2.32	Version.....	201
<b>Annex A (normative): Timers, constants levels and addresses .....</b>		<b>202</b>
A.1	Layer 3 timers.....	202
A.2	Layer 3 constants.....	204
A.3	Layer 3 levels .....	204
A.4	Tier III Gateways/Identifiers .....	205
<b>Annex B (normative): Opcode Reference Lists .....</b>		<b>206</b>
B.1	CSBK/MBC/UDT Opcode List.....	206
B.2	Short Link Control Opcode List.....	206
B.3	Appended Data Information Elements .....	207



B.3.1	Appended Data Binary Format.....	207
B.3.2	Appended Data Addressing Format .....	209
B.3.3	Appended Data BCD Format .....	209
B.3.4	Appended Data ISO 7 bit character set Format .....	211
B.3.5	Appended Data ISO 8 bit Character Format.....	213
B.3.6	Appended Data NMEA (IEC 61162-1) format .....	215
B.3.6.1	Short NMEA (IEC 61162-1) format .....	216
B.3.6.2	Long NMEA (IEC 61162-1) format specified .....	216
B.3.6.3	Long NMEA (IEC 61162-1) format unspecified .....	216
B.3.7	UDT DMR IP format .....	217
B.3.8	Appended Data Unicode 16 bit UTF-16BE Character Format.....	218
<b>Annex C (informative): Physical Channel Plan .....</b>		<b>220</b>
C.1	Transmission and Reception .....	220
C.1.1	RF carriers .....	220
C.1.1.1	Nominal carriers frequencies .....	220
C.1.1.2	Fixed Channel Plan .....	220
C.1.1.3	Flexible Channel Plan .....	222
C.1.1.4	Determination of Transmitter and Receiver frequency from CdefParms .....	222
<b>Annex D (informative): Control Channel Hunting Procedures .....</b>		<b>223</b>
D.1	Introduction .....	223
D.1.1	Resuming a TSCC hunt channel.....	225
D.1.2	Commanded TSCC hunt channel .....	225
D.1.2.1	Conditions to enter a Commanded TSCC hunt.....	225
D.1.2.2	Nominated Channel for the Single Channel Hunt.....	226
D.1.2.3	Short Hunt Sequence .....	226
D.1.2.3.1	Conditions to enter a Short Channel Hunt.....	226
D.1.2.4	Comprehensive Hunt Sequence .....	227
D.1.2.4.1	Conditions to enter a Comprehensive Channel Hunt .....	227
D.1.2.5	Receiver Sensitivity During Control Channel Acquisition .....	227
<b>Annex E (informative): Use of MSC and SDL diagrams.....</b>		<b>228</b>
E.1	Introduction .....	228
E.2	Principle .....	228
E.3	Notation.....	228
<b>Annex F (informative): Bibliography.....</b>		<b>230</b>
History .....		231

---

## Intellectual Property Rights

IPRs essential or potentially essential to the present document may have been declared to ETSI. The information pertaining to these essential IPRs, if any, is publicly available for **ETSI members and non-members**, and can be found in ETSI SR 000 314: "*Intellectual Property Rights (IPRs); Essential, or potentially Essential, IPRs notified to ETSI in respect of ETSI standards*", which is available from the ETSI Secretariat. Latest updates are available on the ETSI Web server (<http://ipr.etsi.org>).

Pursuant to the ETSI IPR Policy, no investigation, including IPR searches, has been carried out by ETSI. No guarantee can be given as to the existence of other IPRs not referenced in ETSI SR 000 314 (or the updates on the ETSI Web server) which are, or may be, or may become, essential to the present document.

---

## Foreword

This Technical Specification (TS) has been produced by ETSI Technical Committee Electromagnetic compatibility and Radio spectrum Matters (ERM).

The present document is part 4 of a multi-part deliverable covering the Technical Requirements for Digital Mobile Radio (DMR), as identified below:

- Part 1: "DMR Air Interface (AI) protocol";
- Part 2: "DMR voice and generic services and facilities";
- Part 3: "DMR data protocol";
- Part 4: "DMR trunking protocol".**

---

# 1 Scope

The present document contains technical requirements for Digital Mobile Radio (DMR) trunking systems operating in the existing licensed land mobile service frequency bands, as identified in CEPT/ERC/T/R 25-08 [10].

The present document describes the trunking services and facilities protocol of a scalable Digital Mobile Radio system, which covers three tiers of possible products:

- Tier I: DMR equipment having an integral antenna and working in Direct Mode (unit-to-unit) under a general authorization with no individual rights operation.
- Tier II: DMR systems operating under individual licences working in Direct Mode (unit-to-unit) or using a Base Station (BS) for repeating.
- Tier III: DMR trunking systems under individual licences operating with a controller function that automatically regulates the communications.**

NOTE: Tier II and Tier III products encompass both simulcast and non-simulcast systems.

The DMR air interface complies with either EN 300 113-1 [1], EN 300 113-2 [2] or EN 300 390-1 [3], EN 300 390-2 [4], that has been specifically developed with the intention of being suitable for all identified product tiers.

The DMR protocol is intended to be applicable to the land mobile service frequency bands, physical channel offset, duplex spacing, range assumptions and all other spectrum parameters without need for any change.

---

# 2 References

References are either specific (identified by date of publication and/or edition number or version number) or non-specific. For specific references, only the cited version applies. For non-specific references, the latest version of the reference document (including any amendments) applies.

Referenced documents which are not found to be publicly available in the expected location might be found at <http://docbox.etsi.org/Reference>.

NOTE: While any hyperlinks included in this clause were valid at the time of publication ETSI cannot guarantee their long term validity.

## 2.1 Normative references

The following referenced documents are necessary for the application of the present document.

- [1] ETSI EN 300 113-1: "Electromagnetic compatibility and Radio spectrum Matters (ERM); Land mobile service; Radio equipment intended for the transmission of data (and/or speech) using constant or non-constant envelope modulation and having an antenna connector; Part 1: Technical characteristics and methods of measurement".
- [2] ETSI EN 300 113-2: "Electromagnetic compatibility and Radio spectrum Matters (ERM); Land mobile service; Radio equipment intended for the transmission of data (and/or speech) using constant or non-constant envelope modulation and having an antenna connector; Part 2: Harmonized EN covering the essential requirements of article 3.2 of the R&TTE Directive".
- [3] ETSI EN 300 390-1: "Electromagnetic compatibility and Radio spectrum Matters (ERM); Land mobile service; Radio equipment intended for the transmission of data (and speech) and using an integral antenna; Part 1: Technical characteristics and test conditions".

- [4] ETSI EN 300 390-2: "Electromagnetic compatibility and Radio spectrum Matters (ERM); Land mobile service; Radio equipment intended for the transmission of data (and speech) and using an integral antenna; Part 2: Harmonized EN covering essential requirements under article 3.2 of the R&TTE Directive".
- [5] ETSI TS 102 361-1: "Electromagnetic compatibility and Radio spectrum Matters (ERM); Digital Mobile Radio (DMR) Systems; Part 1: DMR Air Interface (AI) protocol".
- [6] ETSI TS 102 361-2: "Electromagnetic compatibility and Radio spectrum Matters (ERM); Digital Mobile Radio (DMR) Systems; Part 2: DMR voice and generic services and facilities".
- [7] ETSI TS 102 361-3: "Electromagnetic compatibility and Radio spectrum Matters (ERM); Digital Mobile Radio (DMR) Systems; Part 3: DMR data protocol".
- [8] IEC 61162-1: "Maritime navigation and radiocommunications equipment and systems - Digital Interfaces - Part 1: Single talker and multiple listeners".
- [9] "The Unicode Standard".
- NOTE: Available at: <http://www.unicode.org/standard/standard.html>.
- [10] CEPT/ERC/T/R 25-08: "Planning criteria and coordination of frequencies in the Land Mobile Service in the range 29.7-921 MHz".
- NOTE: Available at <http://www.erodocdb.dk/docs/doc98/official/pdf/Tr2508.pdf>.
- [11] ISO/IEC 646 (1991): "Information technology -- ISO 7-bit coded character set for information interchange".
- [12] ISO/IEC 8859 series (1998 - 2001): "Information technology -- 8-bit single-byte coded graphic character sets".

## 2.2 Informative references

The following referenced documents are not necessary for the application of the present document but they assist the user with regard to a particular subject area.

- [i.1] ETSI TS 102 361-4 (All versions): "Electromagnetic compatibility and Radio spectrum Matters (ERM); Digital Mobile Radio (DMR) Systems; Part 4: DMR trunking protocol".

---

# 3 Definitions, symbols and abbreviations

## 3.1 Definitions

For the purposes of the present document, the following terms and definitions apply:

**1:1-mode:** 1 payload channel mode

NOTE: 1:1-mode supports one "MS to fixed end" duplex call or one simplex call with an optional inbound Reverse Channel using a two frequency BS.

**2:1-mode:** 2 payload channel mode

NOTE: 2:1-mode supports two independent calls which may be either "MS to fixed end" duplex calls or simplex calls using a two frequency BS.

**All\_Unit IDn:** range of MS IDs to address all MS in a system (see TS 102 361-1 [5], annex A)

**ambient listening:** optional form of voice call where the called MS answers then may enters a proprietary listening operation such as transmitting with the microphone mute open

**assigned channel:** channel that has been allocated by the infrastructure to certain MSs using channel allocation command(s) addressed to those MSs

NOTE: An assigned channel may be allocated for secondary control purposes or for a circuit mode call.

**asynchronous access:** mode of operation whereby MS are permitted access to TS by employing the polite protocol defined in TS 102 361-2 [6]

NOTE: In this mode MS are not required to listen to a TSCC to first determine their access rights.

**Base Station (BS):** fixed end equipment that is used to obtain DMR services

**bearer service:** telecommunication service providing the capability for information transfer between access points

**burst:** elementary amount of bits within the physical channel

NOTE 1: The burst may include a guard time at the beginning and end of the burst used for power ramp-up and ramp-down.

NOTE 2: Two bursts with different length are defined for DMR. A TDMA bursts which has a length of 30 ms and a Reverse Channel burst which has a length of 10 ms.

NOTE 3: For detailed burst definition see TS 102 361-1 [5], clause 4.2.1.

NOTE 4: A burst represents the physical content (channel) of a timeslot.

**call:** complete sequence of related transactions between MSs

NOTE: Transactions may be one or more bursts containing specific call related information.

**Caller Line Identity (CLI):** ability to see who is calling you before answering the telephone

**channel:** in the Time Division Multiple Access (TDMA) slot structure arrangement a channel comprises the pair of same numbered slots on the inbound and outbound duplex frequencies

**composite control channel:** TSCC that may temporarily revert to a payload channel (if for instance the instantaneous traffic exceeds that which may be accommodated by the available payload channels)

**Control plane (C-plane):** part of the DMR protocol stack dedicated to control and data services

**coverage area:** geographical area within which the received signal strength from a radiating BS exceeds a specified threshold value

**dedicated control channel:** TSCC that is continuously transmitted by a TS and never reverts to a payload channel

**Digital Mobile Radio (DMR):** physical grouping that contains all of the mobile and/or fixed end equipment that is used to obtain DMR services

**direct mode:** mode of operation where MSs may communicate outside the control of a network

NOTE: This is communication technique where any MS (MS) may communicate with one or more other MSs (MSs) without the need for any additional equipment (e.g. BS).

**downlink:** process of transferring information in the outbound direction (TS to MS)

**duplex:** mode of operation by which information can be transferred in both directions and where the two directions are independent

NOTE: Duplex is also known as full duplex.

**extended address:** source or destination that is not an MS address (such as a PABX extension, PSTN number or IP address)

**First In First Out (FIFO):** storage type that retrieves information in the order in which it was stored

**fixed non-volatile storage:** storage facility within a MS, the contents of which cannot be modified or added to by the operation of the MS or its user

**high-rate:** Packet Data Transmission that uses dual slot data timing

**inbound:** MS to BS transmission

**information element:** subset (field) within a PDU

**intrinsic service:** service which is inherent within a voice or data service

NOTE: It forms an integral part of the signalling associated with that voice or data service.

**item:** MS payload transmission from the point at which the PTT is pressed to the PTT released

**key:** information that determines the functional output of an authentication algorithm

**line connected:** call whereby one end of the call is connected to the radio system that does not use the DMR Air Interface

NOTE: Examples may be connection to the PSTN or a PABX.

**logical channel:** distinct data path between logical endpoints

**message trunking:** mode of operation that a payload channel is permanently allocated for the complete duration of the call, which may include several separate PTT items (several PTT activations by separate terminals)

NOTE: The channel is only de-allocated if the call is (explicitly) released or if a time-out expires.

**Mobile Station (MS):** physical grouping that contains all of the mobile equipment that is used to obtain DMR mobile services

**multi-part call set-up:** call set-up procedure whereby the full source and destination address cannot be accommodated in a single CSBK signalling block

NOTE: The UDT procedure is invoked to transfer the address information using Multi Block Control (UDT) signalling. UDT is also invoked to transport supplementary\_user data, user data and extended addressing between DMR entities.

**network personalization:** configuration parameters appropriate to network configuration programmed into a MS that may be set by an external agency but not by the user of an MS

**non-volatile storage:** read/Write storage that stores information during operation of a MS that is protected from the effects of switching off the MS

**outbound:** BS to MS transmission

**packet data:** method for the transmission of information by which the information is transmitted as packets each containing a fragment of the total information to be transmitted

**PARTition (PAR):** Information Element used to partition MSs on a TS that implements two control channels (TSCCs)

**payload:** bits in the information field

**personalization:** configuration parameters that may be set by an external agency but not by the user of an MS

**physical channel:** TDMA burst

NOTE: The DMR radio frequency channel contains two physical channels.

**polite protocol:** "Listen Before Transmit" (LBT) protocol

NOTE: This is a medium access protocol that implements a LBT function in order to ensure that the channel is free before transmitting.

**power-save-frame:** sixteen time slots (480 ms) defining a period for sleeping MS to wake

**privacy:** secret transformation

NOTE: Any transformation of transmitted information that is derived from a shared secret between the sender and receiver.

**Protocol Data Unit (PDU):** unit of information consisting of protocol control information (signalling) and possibly user data exchanged between peer protocol layer entities

**radio frequency channel:** radio frequency carrier (RF carrier)

NOTE: This is a specified portion of the RF spectrum. In DMR, the RF carrier separation is 12,5 kHz. The physical channel may be a single frequency or a duplex spaced pair of frequencies.

**random access attempt:** period from the initiation of the random access procedure until the MS receives a response from the BS or abandons the procedure (e.g. after sending the maximum permitted number of retries)

**Ready For Communications:** MS state where the user has specifically indicated the readiness to communicate, e.g. the MS equivalent of a telephone off hook

**read write storage:** storage facility within the MS the contents of which may be modified by the operation of the MS. The stored data is lost when the MS is switched off

**Received Signal Strength Indication (RSSI):** root mean squared (rms) value of the signal received at the receiver antenna

**registration (MS view):** network procedure whereby the MS asks for and the TSCC grants access to a particular MS

NOTE: The MS is required to inform the system whenever it enters a new registration area.

**revive:** mechanism whereby DMR facilities available to a MS that has been stunned may be restored

**Service Data Unit (SDU):** all the data encapsulated within a PDU

**servicing site:** radio site that is currently providing service to the MS

**signalling:** exchange of information specifically concerned with the establishment and control of connections, and with management, in a telecommunication network

**simplex:** mode of working by which information can be transferred in both directions but not at the same time

NOTE: Simplex is also known as half duplex.

**single-part call set-up:** call set-up procedure whereby the full source and destination address is accommodated in a single CSBK signalling block

**site:** totality of BSs and trunk site control equipment that processes calls in one location

**slot:** See time-slot.

**stun:** mechanism whereby DMR facilities available to a MS user may be denied

**superframe:** 6 continuous TDMA bursts labelled "A" to "F"

NOTE: A superframe has a length of 360 ms and is used for voice payload only.

**Supplementary Data Transfer Service:** service to transfer supplementary data between DMR MS and MS/TS entities that is additional to the primary call being set-up

**TDMA-frame:** two continuous time-slots

**time-slot:** elementary time unit for allocation of a burst

NOTE: A timeslot has a length of 30 ms.

**transmission:** transfer period of bursts containing information or signalling

NOTE: The transmission may be continuous, i.e. multiple bursts transmission without ramp-up, ramp-down, or discontinuous, i.e. single burst transmission with ramp-up and ramp-down period.

**transmission trunking:** mode of operation that a payload channel is individually allocated for each call transaction (for each activation of the PTT)

NOTE: The channel is immediately de-allocated at the end of the call transaction (subject to unavoidable protocol delays).

**Trunked Station (TS):** physical grouping that contains all of the fixed end equipment in one location that is used to obtain DMR Tier III services

**Trunk Station Control Channel (TSCC):** control channel transmitted by the infrastructure to control the MS population

**TS Authorization:** complete procedure whereby a MS tests the System Identity code and an optional step of authentication to ascertain if it is permitted to gain access

**Unified Data Transport:** universal methodology used to transport data in DMR systems

**Uplink:** process of transferring information in the inbound direction (MS to TS)

**user plane (U-plane):** part of the DMR protocol stack dedicated to user voice services

**vocoder socket:** 216 bits vocoder payload

## 3.2 Symbols

For the purposes of the present document, the following symbols apply:

Hz	absolute frequency
Nibble	4 bits grouped together
Octet	8 bits grouped together, also called a byte

## 3.3 Abbreviations

For the purposes of the present document, the following abbreviations apply:

ACK	ACKnowledgment
ACKU	ACKnowledgement inbound
AI	Air Interface
ALS	Ambient Listening Service
AT	Access Type
BCD	Binary Coded Decimal
BER	Bit Error Rate
BS	Base Station

NOTE: A reference designating a fixed end device.

CACH	Common Announcement CHannel
CC	Colour Code
CCL	Call Control Layer
CH	CHannel
CLI	Caller Line Identity
C-plane	Control-plane
CRC	Cyclic Redundancy Checksum for data error detection
CSBK	Control Signalling BlocK
CSBKO	CSBK Opcode
DEF	DEFinition
DISCON	DISCONnect
DLL	Data Link Layer
DMR	Digital Mobile Radio
DMRLA	DMR Location Area
EMB	Embedded Signalling Field
EN_PTT	Enable_Press to Talk
FEC	Forward Error Correction
FID	Feature set ID
FIFO	First In First Out



FLCO	Full ink Control Opcode
FOACSU	Full Off Air Call Set-up
ID	IDentifier
IP	Internet Protocol
LB	Last Block
LBT	Listen Before Transmit
LC	Link Control
MBC	Multiple Block Control packets
MFID	Manufacturer's FID
MS	Mobile Station

NOTE: A reference designating a mobile or portable radio.

MSB	Most Significant Bit
MSC	Message Sequence Chart
MSID	Mobile Station IDentity
NACKD	Negative ACKnowledgement inbound
NACKU	Negative ACKnowledgement outbound
NET	NETwork
NMEA	National Maritime Electronic Association
OACSU	Off Air Call Set-up
OPCODE	Operation CODE
PABX	Private Automatic Branch eXchange
PAR	PARTition
PDU	Protocol Data Unit
PF	Protect Flag
PL	Physical Layer
PS_RQ	Power Save_ReRequested
PSTN	Public Switched Telephone Network
PTT	Push To Talk
QACK	Queue ACKnowledgement
QACKD	Queue ACKnowledgement outbound
RC	Reverse Channel
RF	Radio Frequency
RFC	Ready For Communications
RSSI	Received Signal Strength Indication
RSVD	ReSerVeD
SAP	Service Access Point

NOTE: Where a network provides a service.

SDL	Specification and Description Language
SDMI	UDT Short Data Message Identity
SEP	SEParation
SFID	Standard FID
SLCO	Short LC Opcode
SYNC	SYNChronization
SYS	SYStem
TDMA	Time Division Multiple Access
TS	Trunked Station
TSCC	Trunk Station Control Channel
UAB	UDT Appended Blocks
UDT	Unified Data Transport
Unicode	16 bit character UTF-16BE encoding
U-plane	User-plane
UTC	Universal Time Coordinated
WACK	Wait ACKnowledgement
WACKD	Wait ACKnowledgement outbound

---

## 4 Overview

The present document describes a Digital Mobile Radio (DMR) protocol for Tier III trunked mobile radio systems that employ a Time Division Multiple Access (TDMA) technology with a 2-slot TDMA solution and RF carrier bandwidth of 12,5 kHz.

Radio equipments (fixed, mobile or portable), which conform to the present document shall be interoperable with equipment from other manufacturers. Radio equipment of the present document shall also comply with TS 102 361-1 [5]. The payload voice channel procedures specified in clause 6.6.2 closely follow the procedures specified in TS 102 361-2 [6], but additional PDUs are prescribed for Tier III operation for channel protection and clear-down. Similarly the packet data is transported on a payload channel described in clause 6.6.3 follow the procedure specified in TS 102 361-3 [7]. Where differences exist those differences are stated in the payload channel clauses of the present document.

Slot formats, field definitions and timing are defined for MS/BS (TS/TSCC) control signalling. The standard can be used to implement a wide variety of systems, from small systems with only a few physical radio channels (even single physical radio channel systems), through to large networks, which may be formed by the interconnection of BS radio sites.

A description of the TDMA structure is provided followed by the basic slot formats and bit definitions appropriate to the trunking protocol. Where procedures are common to the Service and Facilities defined in TS 102 361-2 [6] and TS 102 361-3 [7], only the differences are described in the present document.

The present document does not provide the specification or operational detail for system implementation that include but are not limited to network management, vocoder, security, data, subsystems interfaces and data between private and public switched telephone networks. It describes only the appropriate access requirements compatible with the Air Interface.

The protocol offers a broad range of user facilities and system options. However, it is not necessary to implement any or all of the facilities available; an appropriate subset of the protocol could be implemented, according to the user requirements. Also, there is scope for customization for special requirements, and provision has been made for further standardized facilities to be added to the protocol in the future.

The standard defines only the over-air signalling and imposes only minimum constraints on system design.

Trunked radio systems are characterized by regulating channel access. A logical channel is assigned as a control channel (TSCC). The TSCC has an Inbound path for transmissions from MSs (inbound and outbound path for transmissions from the Trunked Station (TS) to MSs (outbound channel). Control channel packets generated by a Trunk Station Control Channel (TSCC) transmit on the outbound path that all MSs listen to when not involved in a call. MSs request access to the system by random access. The system resources are then granted by the Trunk Station Control Channel (TSCC). This trunking protocol is designed to minimize the signalling required to provide MSs with a particular service in order to provide the greatest possible throughput.

Trunked radio systems may be characterized by the following possible configurations:

- a) Dedicated Control Channel:
  - A Trunk Station Control Channel (TSCC) is transmitted continuously. This channel occupies one DMR TDMA channel. MS access is strictly controlled and access is by invitation only. One TSCC can support a large number of payload channels. There are a number of Tier III services (such as UDT short data messaging) that only utilize the TSCC. This mode of operation yields the highest performance and throughput.
- b) Composite Control Channel:
  - A Trunk Station Control Channel (TSCC) may revert to a payload channel if a payload services is requested and no other payload channels are available. When the payload call is completed, the channel returns to its control channel function. The ability to have composite control channels is of benefit for TS with a very small number of physical radio channels. When the TSCC reverts to a payload function. MS who remain idle lose the control channel and cannot access the system and its services until the control channel returns. Thus the throughput and performance shall be assessed and balanced with the benefits of the additional temporary payload channel. The present document does not specify if a TSCC shall continuously transmit slots inviting access.

- c) "Time Share" Control Channel:
- The term "time-shared control channel" refers to a control channel where multiple TS (whether co-sited or multi-sited) share one physical radio channel for control purposes by dividing the use of the frequency in time. (not to be confused by DMR TDMA). Each TS transmits a burst of control channel activity in turn. This mode of operation is complicated in DMR systems because each physical channel is able to support two independent TDMA logical channels. The present document does not attempt to solve the difficulty. ETSI-DMR does not support time-share control channels.
- d) Asynchronous Access:
- In some radio spectrum, independent users/agencies share frequencies and national administrations mandate that when not transporting payload, the TS shall de-key and yield use of the channel(s) to the co-channel users (i.e. by default, the equipment is de-keyed). Also, there can be no interconnection between the independent users/agencies because, they are independent and may not even be co-located at a site (independent users/agencies may not wish to coordinate use of the channel). Additionally, some co-channel users may just be conventional talk-around users, in which case there is no fixed end equipment to coordinate. What may be practical in this scenario is to trade-off (or sacrifice) control channel capacity/performance for the ability to support trunking. The present document provides the facility for MS to activate a physical TSCC channel whereupon a short burst will regulate and invite access.

## 4.1 Protocol architecture

The purpose of this clause is to provide a model where the different functions and processes are identified and allocated to different layers in the DMR protocol stack.

The protocol stack in this clause and all other related clauses describe and specify the interfaces, but these stacks do not imply or restrict any implementation.

The DMR protocol architecture that is defined herein follows the generic layered structure, which is accepted for reference description and specification of layered communication architectures.

The DMR standard defines the protocols for the following three-layered model as illustrated in figure 4.1.

The base of the protocol stack is the Physical Layer (PL), which is the layer 1.

The Data Link Layer (DLL), which is the layer 2, shall handle sharing of the medium by a number of users. At the DLL, the protocol stack shall be divided vertically into two parts, the User plane (U-plane), for transporting information without addressing capability (e.g. voice or data stream), and the Control plane (C-plane) for signalling with addressing capability, as illustrated by figure 4.1.

The Call Control Layer (CCL), which is layer 3, lies in the C-plane and is responsible for control of the call (addressing, facilities), provides the services supported by DMR, and supports the Data Service. U-plane access at layer 2 (DLL) supports voice and packet data service, which is available in DMR. The Control Layer and the facilities and services offered by Tier III DMR are described in the present document.

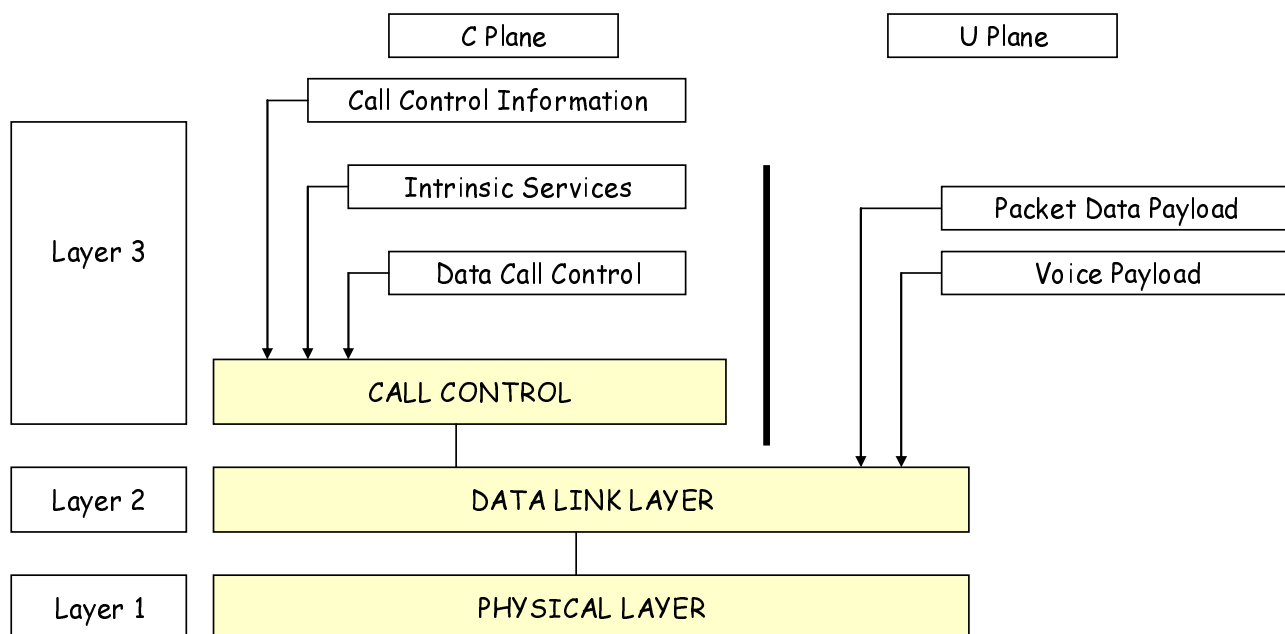

**Figure 4.1: DMR protocol stack**

#### 4.1.1 Air Interface Physical Layer (layer 1)

The Air Interface layer 1 shall be the physical interface. It shall deal with the physical burst, composed of bits, which is to be sent and/or received. The Physical Layer is described in part1 of this multi-part deliverable, see TS 102 361-1 [5].

The Air Interface layer 1 contains the following functions:

- modulation and demodulation;
- transmitter and receiver switching;
- RF characteristics;
- bits and symbol definition;
- frequency and symbol synchronization;
- burst building.

#### 4.1.2 Air Interface Data Link Layer (layer 2)

The Air Interface layer 2 handles logical connections and hides the physical medium from the upper layers. The Data Link Layer is described in clauses 5 to 9 of TS 102 361-1 [5]. Layer 2 services are described in the present document if those services are not already described in TS 102 361-1 [5].

The main functions are as follows:

- channel coding (FEC, CRC);
- interleaving, de-interleaving and bit ordering;
- service answer response and retry mechanism;
- media access control and channel management;
- framing, superframe building and synchronization;
- burst and parameter definition;

- link addressing (source and/or destination);
- interfacing of voice applications (vocoder data) with the PL;
- data bearer services;
- exchanging signalling and/or user data with the CCL;
- authentication by challenge and response.

### 4.1.3 Air Interface Call Control Layer (layer 3)

Air Interface layer 3 (CCL) is applicable only to the C-plane, and shall be an entity for the services and facilities supported by DMR on top of the layer 2 functionality. The Call Control Layer for trunking described in the present document and may have embedded intrinsic services associated to it.

The CCL provides the following functions:

- BS/TS/TSCC activation / deactivation (for asynchronous access mode);
- establishing, maintaining and terminating of calls;
- individual or talkgroup call transmission and reception;
- destination addressing (DMR IDs or gateways as appropriate);
- support of intrinsic services (emergency signalling, pre-emption, late entry, etc.);
- data call control;
- announcement signalling;
- management of available resources:
  - management of a control channel resource by a random access protocol;
  - queuing for payload resource;
- individual or talkgroup call set-up via a dedicated signalling channel;
- MS location information by registration;
- MS power save;
- broadcast of system parameters to radio subscriber terminals.

## 4.2 Services and Facilities

A Tier III system is able to support either a wide range or narrow range of Services and Facilities. Users who select a service specified in the present document that is not supported by a particular system shall receive an unambiguous refusal of service response.

The services and facilities defined in the present document may be used for Tier III products and is called the "default feature set" which is allocated to the "Standards Feature ID (SFID)". There is a possibility in the DMR standard which allows manufacturers to define and implement "private" feature sets which contain additional "private" services and facilities, which may possibly not be understood by products not supporting this "private" feature set. In addition, some "Standards Feature ID" PDUs may contain optional manufacturer specific information elements.

The "standard feature set" contains the following services and facilities:

- a) Generic services:
  - 1) MS Access control and management using a control channel and a random access protocol;
  - 2) MS Location within the system radio coverage by radio site identification and registration;
  - 3) Control Channel hunting;
  - 4) System acquisition authorization;
  - 5) A Unified Data Transport mechanism to support the UDT short data service, the supplementary\_user data service and extended\_addresses through gateways;
  - 6) Broadcast of system parameters to MS;
  - 7) MS Authentication;
  - 8) Feature Not Supported;
  - 9) MS dynamic power control;
  - 10) MS Pre-emption control.
- b) Primary voice services:
  - 1) talkgroup call service;
  - 2) individual call service.
- c) Secondary voice services:
  - 1) all\_MS call service;
  - 2) broadcast voice call service;
  - 3) open voice channel mode call service.
- d) Primary Data Services:
  - 1) Short Data Service;
  - 2) Packet Data Service.
- e) Status Service:
  - a) Status Delivery Service;
  - b) Status Polling Service.
- f) Supplementary Service:
  - 1) Supplementary\_user data transfer service. (additional data sent as part of the primary call set-up);
  - 2) MS stun and revive;
  - 3) MS Kill;
  - 4) Answer Call Service;
  - 5) Cancel Call Service.

The description of the services and features use diagrams where necessary to illustrate and highlight specific points both on the control channel and payload channel.

## 4.3 Device Addresses

### 4.3.1 MS Addresses

Tier I and Tier II MSs shall be personalized with at least one individual **or** one talkgroup identity (TS 102 361-2 [6], clause C.2.2). Tier III MSs shall be personalized with at least one individual identity and may be a member of one or more talkgroups.

NOTE: MS individual addresses and talkgroups occupy separate address space (see TS 102 361-1 [5], annex A). Thus it is possible that a talkgroup may have the same numeric address value as an individual MS numeric address value. There is no ambiguity because the individual and talkgroup call services are separately identified in all PDUs where a particular address information element may carry either an MS ID or talkgroup.

This protocol is able to make use of the user and number dialling plan described in TS 102 361-2 [6] DMR voice and generic services and facilities annex C.

### 4.3.2 Services and Gateway Addresses

The Tier III protocol defines additional addresses to identify Services and Gateways in PDUs exchanged between MS and TS (TS 102 361-1 [5], annex A). The addresses prescribed for Tier III systems are defined in clause A.4.

## 4.4 Conventional/Trunked Systems

Conventional Tier I and Tier II DMR systems permit MS to control their own channel access (subject to any polite protocol).

Many of the conventional operations such as selection of the physical radio channel is automated by this protocol:

- a) A single site trunked network is characterized by multiple MS communicating with a single location Trunked Station (TS);
- b) A wide area trunked network is characterized by multiple MS communicating with a multiplicity of Trunked Stations (TS).

A TS shall be equipped with one or more physical channels. Each TS may be configured with one or two control channels (TSCCs). Where two TSCCs are configured, the TSCCs may be arranged in one physical channel or separate physical channels. The Tier III protocol can separate the population of MS fleets between multiple TSCCs so that there is effective load sharing.

For a fully regulated system, at least one channel shall be configured as a Trunk Station Control Channel (TSCC) for MS management, signalling, and broadcast of system parameters. MS access is strictly controlled on the TSCC.

An unregulated asynchronous system shall permit MS access subject to polite rules.

## 4.5 MS Location

As MS travel around a wide area network they may be within range of a number of different Trunked Stations (TSs). Registration is a method by which the system can determine which radio site or group of radio sites MSs are located within a wide area network. This information avoids searching for MSs throughout the whole network, consequently reducing call set-up time and control channel loading.

Registration may also be employed by a Single Site system to determine when MSs are active and able to receive calls.

A secondary application of the registration process is that it enables power save parameters to be passed between MS and the system.

If an MS is switched off or is subjected to a user selected change of network, the MS may attempt to de-register. The MS makes a de-registration random access to the TSCC on a "best endeavours" basis. If the procedure is not completed within a short time window (T\_dereg) the process is abandoned.

## 4.6 Tier III Services

A DMR TS can allocate resources for a range of services including individual call, talkgroup call, line connected call, and a selection of data services.

Calls to talkgroups may be restricted by the Network to a single radio site or connected to a multiplicity of radio sites. The particular sites involved in the call may be defined by the Network using manual configuration or automatic selection.

Supplementary data may be sent between MS and the network during the call set-up phase using the Supplementary Data Transfer Service to poll for, or deliver additional information using a Unified Data Transport method. Examples include:

- a) the inbound transport of extended\_addressing dialling digits for calls to the PSTN, PABX extensions or dotted addresses for IP gateways;
- b) the transport of MS location information using data collected from IEC 61162-1 [8] compatible devices;
- c) the transport of any supplementary\_user data;
- d) the outbound transport of CLI information for calls from PSTN, PABX LINE and dispatcher gateways to the called MS(s);
- e) the outbound transport of an IP address to called MS.

### 4.6.1 MS initiating calls

A MS may initiate a call to any of the following called parties:

- a) an individual MS;
- b) a line-connected terminal device including a PABX extension or PSTN destination;
- c) a talkgroup, or all MSs in the system.

The system shall send a refusal of service response to any calls that request inappropriate Services and Facilities for a particular destination address.

Some services may be addressed to the TS itself.

During the call set-up phase, the TSCC may pass information back to the caller, to indicate the progress of the call. For example, it shall indicate the reason for any delays in call set-up or the reason for a call failure.

### 4.6.2 MS receiving calls

A MS may receive calls from a MS or line connected terminal device (such a device may be a PABX extension or the PSTN).

In addition, some PDUs may originate from the TS itself.

A MS shall send an acknowledgement rejecting any individual call that request inappropriate or unsupported Services and Facilities.

For a call from an MS, the calling address shall be supplied to the called unit. For a call from certain line connected gateways such as a PABX extension or from the PSTN, the protocol enables Source Address information to be carried to the MS. (An example is CLI information from a PABX extension or the PSTN.)

Incoming calls may be addressed to the MS individually or to a talkgroup.

A called MS may transmit different types of acknowledgements to a calling MS unit, depending on whether a user answers a call, whether a call enters a call stack or whether a voice message should be left. The acknowledgements can be used by a calling radio to provide call progress indications, such as informative text and/or alerts, to the user of the calling MS.



### 4.6.2.1 MS receiving individual calls

A MS may refuse to accept all incoming calls, for example by means of a "will call-back" control, or incoming calls could be refused selectively, depending on the source of the call. If an MS user does not wish to proceed with an incoming call immediately, the user can indicate that the call will be returned. If a MS user does not wish to receive any incoming calls, the calls may be rejected completely.

For voice calls, a system may employ two strategies as shown in clauses 4.6.2.1.1 and 4.6.2.1.2.

#### 4.6.2.1.1 Off Air Call Set-Up (OACSU)

The TS determines when the traffic channel is to be assigned. The assignment may be performed at any time after call establishment has been initiated in the TS. A traffic channel is allocated for the call whether or not the called party answers.

#### 4.6.2.1.2 Full Off Air Call Set-Up (FOACSU)

The traffic channel is only assigned when the called party user has specifically answered the call. When the called party has answered, the network initiates the traffic channel assignment in order to allocate a traffic channel to the MS.

### 4.6.2.2 MS receiving calls to talkgroups

A MS may be a member of an arbitrary number of talkgroups.

An MS may be configured such that it may selectively accept or ignore a call to one of its talkgroup memberships. An MS may also be configured to ignore a call to one of its talkgroup memberships if it is waiting for an individual call.

### 4.6.2.3 MS receiving calls to All\_MS

A number of IDs are reserved for the purpose of addressing every MS on a radio site, radio sites or system. There are three identities defined, ALLMSID, ALLMSIDL, or ALLMSIDZ. Calls to these identities are treated by the present document as broadcast calls to a talkgroup. It is manufacturer specific that the TSCC sends and the MS accepts calls to these identities.

## 4.7 Physical Link Organization

This protocol makes use of the physical layer 1 prescribed in TS 102 361-1 [5] DMR Air Interface protocol.

### 4.7.1 Radio Frequency Allocation

The Tier III protocol supports a number of different physical channel strategies to accommodate operation in radio channels that may be dedicated, in blocks or re-farmed.

Physical radio channels may be specified by either:

- a) a logical channel plan whereby a transmitter and receiver frequency is mapped to a logical channel number. The Tier III protocol permits up to 4 094 such logical / physical relationships; and/or
- b) a mechanism whereby the absolute transmitter and receiver frequencies are specified in the PDUs that are passed between BS and MS at the air interface.

### 4.7.2 Colour Code (CC)

A Colour Code (CC) is present in the Embedded Signalling Field (EMB) and general data burst to provide a simple means of distinguishing overlapping sites, in order to detect co-channel interference. Tier III systems assign the physical channels automatically therefore the MS and TS shall know and be in agreement which colour code is allocated for each physical channel. The following strategy is employed in Tier III systems:

- a) The default colour code is 0000<sub>2</sub>. If a colour code has not been specifically assigned, or transmitted on the TSCC in an extended Channel Grant or extended Move PDU, the colour code shall be set to the default.

- b) In Tier III systems MS shall be polite to own colour code.
- c) MS may maintain a list of logical channel numbers and their corresponding colour code assignments (see annex C).

## 4.8 DMR TDMA burst and channel structure

The described solution is based on the 2-slot TDMA structure described in TS 102 361-1 [5], clause 4.2.

The logical channels are separated into two categories:

- a control channel carrying signalling; and
- payload channels carrying speech or data information.

Generally MSs operate in half duplex mode using aligned channel timing (see TS 102 361-1 [5], clause 5.1.1) but full duplex is possible for calls to line connected terminals using Offset TDMA timing (see TS 102 361-1 [5], clause 5.1.1.2) by allowing a MS to transmit in one time slot and receive the fixed end transmission on the alternate time slot. MS that are directed to a physical channel using offset timing shall be notified by an identifier transmitted to the MS(s) during the call set-up.

A generalized diagram of exchanges between the TSCC and MS is illustrated in figure 4.2 where the slots for the two TDMA physical channels are shown.

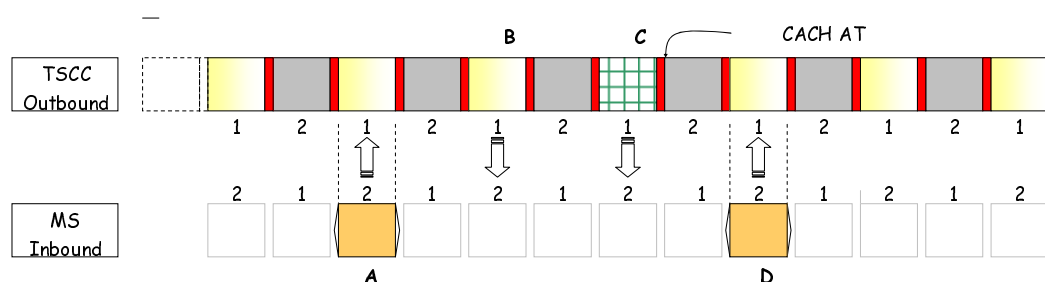

**Figure 4.2: Key points for a Tier III TSCC**

Key points particular to Tier III trunking illustrated by figure 4.2 include the following:

- While the TSCC is keyed up, the two outbound logical channels are continuously transmitted, even if there is no information to send. If either of the logical channels is configured as a control channel, and that control channel is idle, information is constantly transmitted to manage MS access and broadcast parameters to MSs.
- The channel 1 and 2 bursts in the inbound channel are offset 30 ms in time from the channel 1 and 2 bursts in the outbound channel. This number scheme allows a single channel identifier field in the outbound CACH to use the same channel number when referring to the inbound and outbound channels.
- Differing SYNC patterns are used in voice bursts and data bursts to allow the receiver to differentiate between them. Different SYNC patterns are used for inbound and outbound channels to help the receiver reject co-channel interference.
- In the present document a physical channel that carries a TSCC shall use aligned timing as prescribed in clause 5.1.1.1 of TS 102 361-1 [5]. Two independent control channels or one control channel + one payload channel may be configured. A TSCC may temporarily revert to a payload channel. A future version of the present document may permit a TSCC that uses offset timing to enable full duplex MS to MS calls in a single two slot carrier and full duplex Line Connected (for example PSTN,PABX) calls in a single slot.
- Referring to figure 4.2, a random access burst on the inbound channel labelled "A" shall be acknowledged by a PDU on the outbound channel. This acknowledgement may be transmitted in slot "B", although the protocol is able to postpone the acknowledgement to allow for computational or network delays.
- For a MS response to a PDU received from the TSCC, the MS shall transmit its PDU in the timeslot but one following the end of the TSCC PDU. I.e. a PDU from the TSCC in slot "C" that requires a response from a MS shall be acknowledged on the TSCC in slot "D".

- The MS response at "D" cannot collide with another random access burst because the slot is protected by setting the AT bit in the CACH to busy. MS shall test this bit before making a random access attempt. Random access is not permitted if AT=1.
- The outbound channel defines a CACH channel between TDMA bursts that manages the framing and channel access of the logical channels and provides a low speed channel for signalling. CACH framing bits are defined, allowing the low speed channel to support a range of PDU sizes.

## 4.9 Introduction to the TS Structure

These clauses outline some key aspects of the Tier III protocol by reference to examples. The Tier III protocol manages MS access and Service provision by means of a TSCC (control channel). MSs request Service by means of random access. The Tier III protocol provides a wide variety of configurations to match the requirements of dedicated and shared radio spectrum. The TSCC outbound channel may be:

- continuously transmitting slots that invite MS access, broadcast of system parameters to, and managing the resources that are available to MS;
- transmitting information as a) but reverting to a payload channel when other payload channels are not available;
- de-keyed until activated by an MS burst when used in shared spectrum.

### 4.9.1 An individual voice call example

#### 4.9.1.1 Individual Call using OACSU

Two MS, MS(A) and MS(B) are active listening to the TSCC. MS(A) requests a voice service to MS(B). Before a payload channel is assigned on the TSCC, the system checks that the MS(B) is in radio contact and wishes to accept the call. If MS(B) sends a positive acknowledgement response (indicating that MS(B) will accept the call), the system allocates a payload channel for the call.

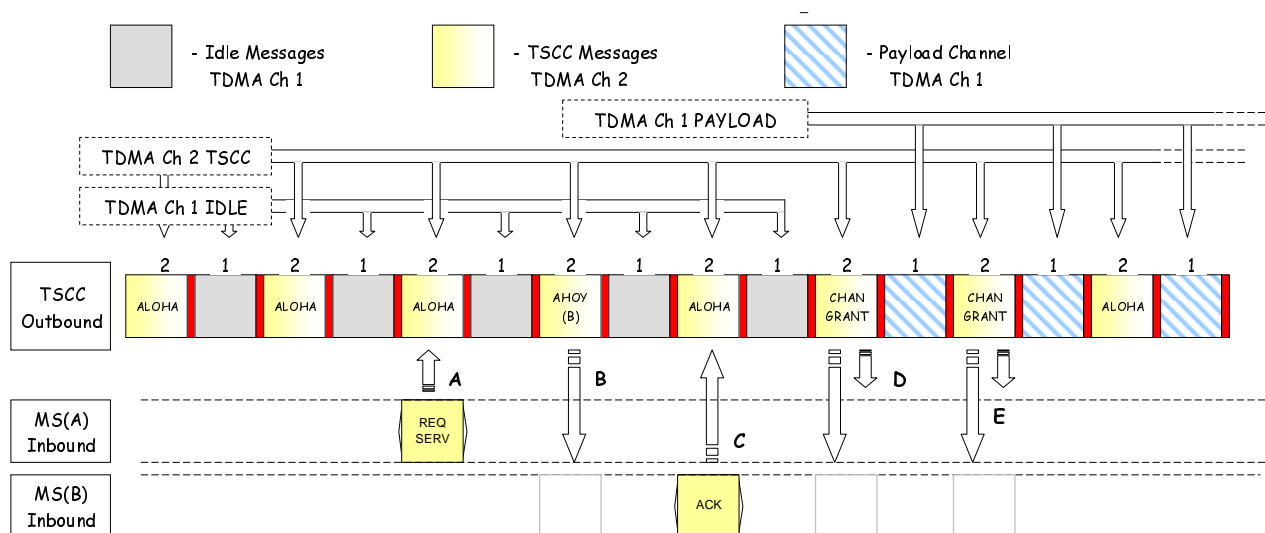

Figure 4.3: Individual Call Set-up example using OACSU

Referring to figure 4.3, some key aspects are described:

- TDMA Channel 2 is assigned as a TSCC. TDMA Channel 1 is idle.
- When a TSCC has no calls in progress, it will transmit system management or system broadcast PDUs to all MSs listening to the TSCC. MSs may listen to TDMA Channel 1 for the purposes of error rate measurement but they shall not make use of any information from those PDUs.
- MS(A) makes a Service Request at point "A" using aligned timing (see TS 102 361-1 [5], clause 5.1.1.1).

- d) The TSCC sends an AHOY PDU (point "B") addressed to MS(B) that requires an acknowledgement response.
- e) MS(B) responds with an acknowledgement at point "C".
- f) At point "D", the TSCC sends a Channel Grant PDU addressed to MS(A) and MS(B). A logical channel information element in the Channel Grant PDU directs the MSs to a particular physical and logical channel. The Channel Grant PDU is not acknowledged so the PDU is repeated for reliability at "E". A TSCC may transmit the repeated Channel Grant PDUs consecutively, or wait for a few slots before repeating the Channel Grant.
- g) In this particular example the TSCC has chosen to allocate the logical Channel 1 of this physical channel for the call. Logical Channel 1 therefore changes from idle to payload immediately after the TSCC transmits the first Channel Grant PDU.
- h) Since each TDMA burst takes 30 ms, the best case performance for a Tier III individual call set-up is 210 ms.

#### 4.9.1.2 Individual Call using FOACSU

Two MS, MS(A) and MS(B) are active listening to the TSCC. MS(A) requests a voice service to MS(B). The TSCC checks that the MS(B) is in radio contact and wishes to accept the call. If MS(B) sends a positive acknowledgement, MS(B) alerts the user. Only when MS(B) answers the call does the system allocate a payload channel for the call.

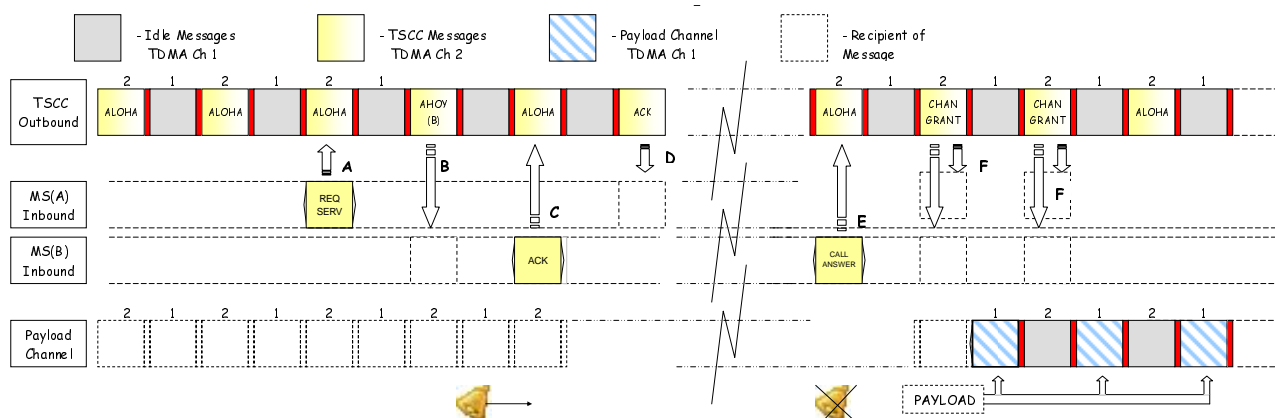

**Figure 4.4: Individual Call Set-up example using FOACSU**

Referring to figure 4.4, some key aspects are described:

- a) TDMA Channel 2 is assigned as a TSCC. TDMA Channel 1 is idle.
- b) MS(A) makes a Service Request at point "A" using aligned timing (see TS 102 361-1 [5], clause 5.1.1.1).
- c) The TSCC sends an AHOY PDU (point "B") addressed to MS(B) that requires an acknowledgement response.
- d) MS(B) responds with an acknowledgement at point "C". MS(B) alerts the user.
- e) The TSCC sends a mirrored acknowledgement PDU (point "D") back to MS(A) to indicate to MS(A) that MS(B) is alerting.
- f) The user actively answers the call at point "D" causing MS(B) to send a Answered Request to the TSCC, the TSCC sends a Channel Grant PDU addressed to MS(A) and MS(B). the alert generated at point "C" is cancelled.
- g) A logical channel information element in the Channel Grant PDU directs the MSs to a particular physical and logical channel. The Channel Grant PDU is not acknowledged so the PDU is repeated for reliability at "F". A TSCC may transmit the repeated Channel Grant PDUs consecutively, or wait for a few slots before repeating the Channel Grant.

In this particular example the TSCC chooses a separate physical radio channel for the call. The particular physical and logical TDMA channel information elements are carried in the Channel Grant PDUs. The Channel Grant PDUs are repeated for reliability.

## 4.9.2 A talkgroup call example

For a talkgroup call, the intermediate step of checking if MS(B) is in radio contact is not required so the best case performance for a Tier III talkgroup call is 90 ms.

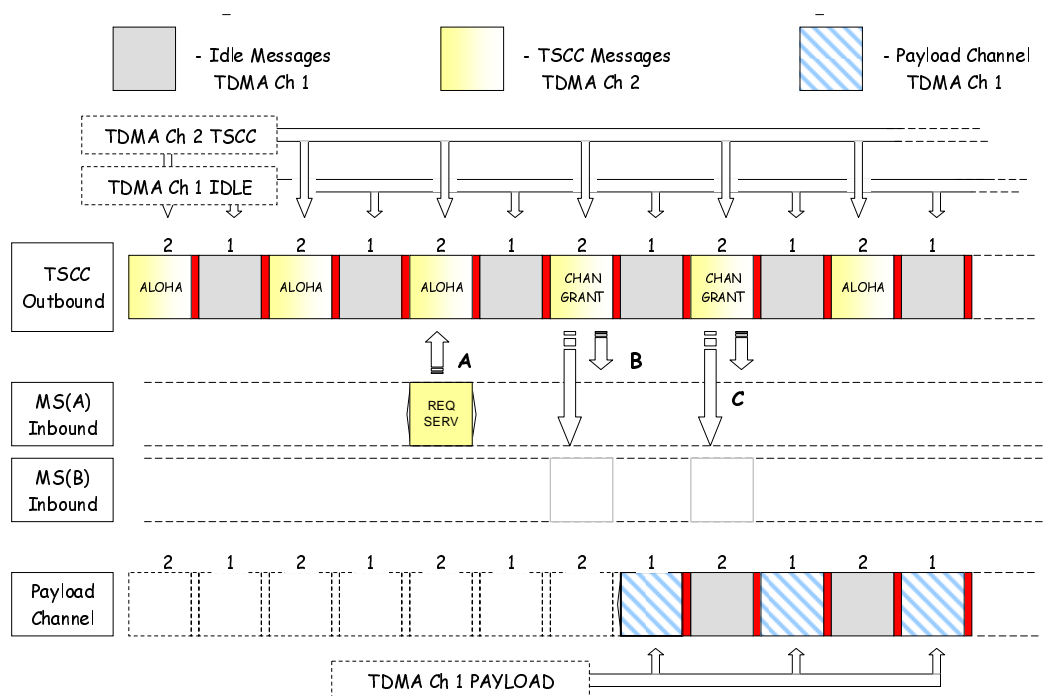

**Figure 4.5: Talkgroup Call set-up example**

Figure 4.5 illustrates a call set-up for a talkgroup. MS(B) is a party to that talkgroup. For a talkgroup call, the intermediate step of checking if MS(B) is in radio contact is not required so the best case performance for a Tier III talkgroup call set-up is 90 ms.

In this particular example the TSCC chooses a separate physical radio channel for the call. The particular physical and logical TDMA channel information elements are carried in the Channel Grant PDUs. The Channel Grant PDUs are repeated for reliability.

Key protocol aspects are:

- When both payload channels are idle, no radio transmission is necessary.
- When at least one payload channel is assigned the transmitter is activated and one logical channel carries the payload for the call. The other logical channel remains idle.
- Although in this example the clocks and bursts in the payload channel are time aligned with the TSCC, there is no requirement to do so.

## 4.10 Network architecture

The DMR trunked protocol is defined in terms of the Services and Facilities. It is defined to ensure interoperability with DMR MSs. The Tier III structure relies on the Air Interface TS 102 361-1 [5].

The gateways to Public Switched Telecommunication Network (PSTN), and other non Air-Interface gateways are not defined within the present document. They are shown only for informative purposes.

A Trunked Station (TS) consists of one or more physical radio channels (BS), each physical channel supporting two TDMA logical channels. Either or both logical channels of a BS may carry a TSCC. All of the clocks of the BS making up a TS may be derived from a common reference standard so that the framing structure is synchronized across all BS within a TS.

## 4.10.1 Network functions

In addition to the normal call handling functions required to provide the telecommunication services identified above, a number of standard network procedures are needed for the efficient operation of the system and to provide an acceptable grade of service to the users.

### 4.10.1.1 Establishing service

A notable feature of a Tier III trunked system is that physical channel acquisition is performed automatically when a MS is powered up. The user does not need to manually select physical channels. The relevant physical channel is stored in the MS or a search is performed to find an applicable TSCC. If the MS is directed to a payload physical channel on the TSCC, the applicable payload channel is transmitted to the MS by a Channel Grant PDU that specifies the physical and logical channel.

### 4.10.1.2 Network Identifier

All TS carry a network and radio site identifier. This identifier, the System Identity Code (C\_SYSCode) is transmitted frequently by a TSCC. The C\_SYSCode is carried in CSBK signalling packets and also embedded in the CACH. The C\_SYSCode is composed of MODEL, NET, SITE and PAR information elements. Within a particular network, the MODEL and NET remains a constant. Each TS is designated a different SITE parameter. MSs use the MODEL and NET to determine if they are authorized to attempt to become active on that network.

## 4.10.2 MS Location by Registration

The coverage area of a Tier III trunked network is divided into a number of Location Areas (DMRLAs). A DMRLA corresponds to a single radio site or a small number of radio sites structured as a DMRLAs.

Implicit registration is the network functionality that registers the location of the MS without need for an explicit registration PDU. Implicit registration can be attained by any system PDU that conveys the MS individual identity, e.g. call request, service answer response.

It is possible that due to adverse conditions the registration information held by the network and that held by the MS may not be the same. To restore and maintain the registration records:

- a) The system shall update its registration records from MS random access call requests (the network may however deny the service requested by the MS for other reasons).
- b) Responses from MS (resulting from a radio check for example) implicitly update the system registration records.

## 4.11 Trunking methods

DMR Tier III systems are able to implement the "message trunking", "transmission trunking" or "quasi-transmission" trunked methods.

### 4.11.1 Message trunking

Message trunking is a payload channel allocation strategy in which the same payload channel is continuously allocated for the duration of a call, which may include several separate call items or transactions (i.e. PTT activation by separate terminals). The payload channel is only de-allocated when the call is explicitly cleared by the call owner in the case of a talkgroup call, either party hanging up during an individual call or if an activity timer expires. The BS may also clear the call at any time but the BS shall be confident that all parties in the call hear the PDU to clear down the call.

Once a payload channel has been allocated the users will experience the minimum delay for each transmission item since there is no queuing for the allocation of channel resources. The absence of any perceptible delay when the PTT is activated ensures that a conversation can proceed without interruption. This strategy is likely to minimize the processing and signalling overheads in the network infrastructure.

The disadvantage of this strategy is that the channel remains allocated even when there may be significant gaps in the PTT items and this may result in less efficient use of the available channel capacity.

### 4.11.2 Transmission trunking

A payload channel is allocated for each PTT item. When the user releases the PTT, the payload channel is de-allocated down and the MS returns to the control channel. The following PTT is allocated a new payload channel.

Users may experience a delay for each transmission item particularly when the system is busy because a payload channel may not be immediately available. In this case the system shall queue the MS until a payload resource becomes available. An indication may be provided to the user that the payload channel is allocated for the speech item.

### 4.11.3 Quasi-Transmission trunking

A payload channel is allocated to the called and calling parties at the start of the call. When the user releases the PTT, a short hang-timer holds the payload channel to permit the other party to speak. If the hang-timer expires the payload channel is de-allocated and the next PTT item sets up a new call. This method overcomes the delay in transmission trunking but users experience different effects depending on the possible expiry of the hang-timer.

## 5 Trunking Control Channel Formats

A TS shall employ a minimum of one physical channel partitioned in time into TDMA frames and timeslots as defined in TS 102 361-1 [5], clause 4.2. At least one of the TDMA channels shall carry control channel signalling. When idle, MSs shall monitor the Trunk Station Control Channel (TSCC) outbound channel. This protocol permits one additional TSCC to be employed in a TS to share the load.

The following SYNC patterns shall be deployed (see TS 102 361-1 [5], clause 9.1.1 for details and bit patterns for the frame SYNC):

- For the TS outbound channel - BS sourced data.
- For the MS inbound channel - MS sourced data.

Signalling on the TSCC outbound channel is nominally continuous, with each TDMA Frame comprising two independent logical channels. The channel consists of two TDMA traffic channels (channels 1 and 2) as well as a CACH for channel numbering, channel access, system identification and power save.

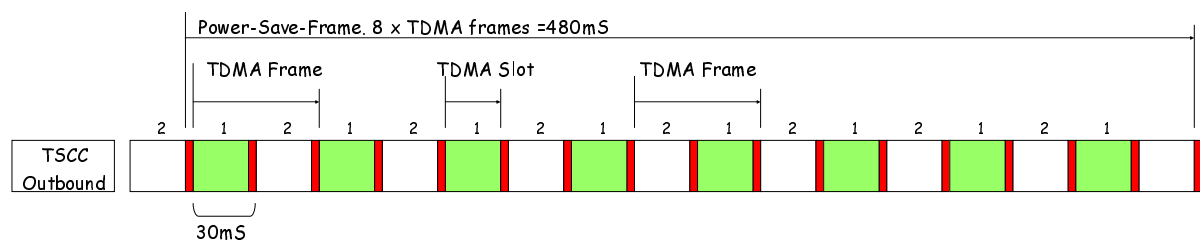

**Figure 5.1: Slots and Frames**

Figure 5.1 illustrates slots, TDMA frames, random-access-frames and power-save-frames.

A slot is the elementary DMR burst described in TS 102 361-1 [5].

A TDMA-frame encompasses two continuous time slots 1 and 2 or 2 and 1.

A power-save-frame is defined by transmission of four consecutive Short LC PDUs embedded in the CACH. A power-save-frame is transmitted by a TSCC every 480 ms.

## 5.1 The use of the CACH

The Short LC contains 3 octets of data associated with the SYS\_Parms Short Link Control (Opcode - 0010<sub>2</sub>) (see TS 102 361-1 [5], clause 7.1.4). Tier III systems that have any one of the logical channels configured as a TSCC shall continuously or periodically transmit the SYS\_Parms Short Link Control to broadcast a sub-set of the System Identity Code, the Reg information element and a Common\_Slot\_Counter. All information carried by the Short Link Control is common to both logical channels.

Since the entire Short LC payload can be delivered in 4 CACH bursts, one SLCO can be sent by the CACH every  $4 \times 30 \text{ ms} = 120 \text{ ms}$ .

**NOTE:** The Tier III protocol makes use of the AT bit transmitted in the CACH as key elements in the random access protocol described in clause 6.2.

### 5.1.1 SYS\_Parms - System Identity Code Subset

The full C\_Syscode information element is length 16 bits. Only the most significant 14 bits of the C\_SYScore are carried in the CACH because the CACH is common to the two logical channels. One physical channel may carry one or two TSCCs. Each TSCC is identified by the two bit PAR information element that is conveyed in the two Least Significant Bits (LSBs) of the C\_SYScore.

The CACH is common to both logical channels so the PAR field cannot be specified in the CACH. Not all CSBKs on the outbound channel contain the SYScore. If a MS is searching for a control channel and trying to determine if it is permitted access, it may disregard a sampled channel by decoding the CACH. If there is no match then the MS does not need to stay looking for a CSBK that contains the C\_SYscore.

### 5.1.2 SYS\_Parms - Reg

The Reg information element carries a flag that specifies if this particular system requires MS to register before becoming active. The Reg is also carried in the Aloha CSBK PDU.

### 5.1.3 SYS\_Parms - Common\_Slot\_Counter

The Common\_Slot\_Counter is broadcast by the SYS\_Parms and represents a positive integer in the range 0 to 511. The counter is incremented in each successive SYS\_Parms Short Link Control PDU. When the counter is incremented from 511 it rolls over to 0. The Common\_Slot\_Counter therefore increments every 120 ms.

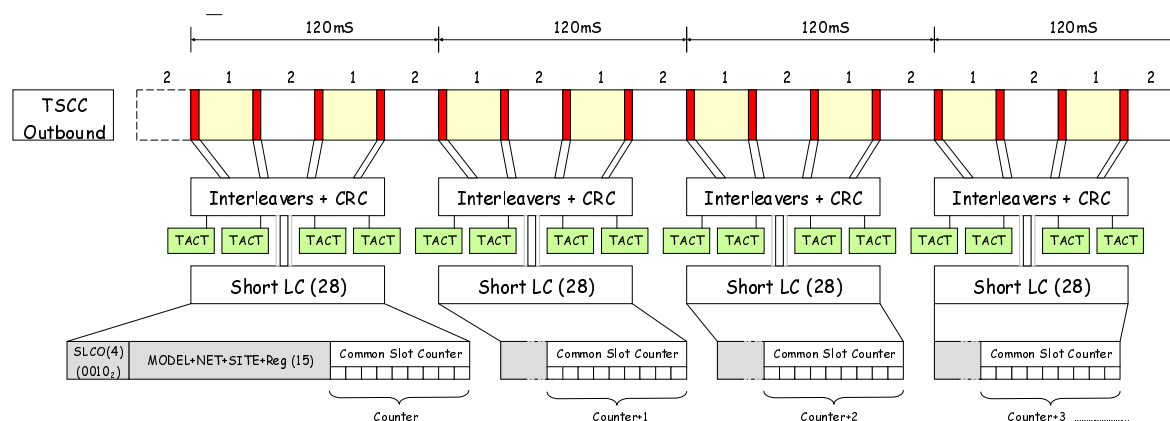

**Figure 5.2: Common Slot Counter**

Figure 5.2 shows how the Common Slot Counter is broadcast in the CACH. The Common\_Slot\_Counter is read by MS wishing to synchronize power save periodic sleep cycles (see clause 6.4.7).



## 5.2 Tier III signalling

The Tier III protocol makes use of the single block CSBK and Multiple Block Control signalling packet structure described in TS 102 361-1 [5], clause 7.2. PDUs addressed to an individual MS or a talkgroup shall contain the Source Address. The Tier III protocol also uses the Unconfirmed Data type for the Unified Data Transport mechanism. UDT blocks consist of a header and a number of intermediate blocks contiguously transmitted. The UDT transmits the UDT header followed by one to four appended data (UDT intermediate blocks) to transport variable length system, user data or extended\_addresses between entities.

## 5.3 Modes of control channel

TSCCs may be dedicated, composite or asynchronous. A dedicated TSCC never reverts to a payload channel whereas a composite TSCC may change its mode and carry payload if all other payload channels within a particular TS are busy.

### 5.3.1 Dedicated TSCC

A dedicated TSCC is generally employed in a TS where a large number of BS (hence payload channels) are employed. The advantages of a dedicated TSCC are:

- a) the TSCC is always available for MS who are hunting for a appropriate and valid service;
- b) the TSCC is always available to process secondary services such as MS location (registration), UDT short data calls, etc.;
- c) the TSCC is always available to accept random access requests and queue such requests if resource is not immediately available;
- d) the TSCC can broadcast information to MSs more frequently as the TSCC function is not interrupted.

### 5.3.2 Non-Dedicated TSCC

A composite TSCC may suspend its control channel function and revert to a payload mode. This is suitable for TSs that are equipped with a very small number of payload channels and the traffic expected exceeds the capacity of those channels. The control channel reversion provides one additional payload resource. However, the shortcomings are:

- a) MS who are hunting for a appropriate and valid service may sample the physical channel when it has reverted to payload and therefore skip the channel;
- b) the TSCC is not available to process secondary services such as MS location (registration), UDT short data calls, etc.;
- c) the TSCC cannot accept random access requests. The control channel interruption will most likely cause the MS not involved in the call to hunt;
- d) MS that return from a payload channel expecting the TSCC to be present will see a payload channel and therefore hunt for a new control channel.

### 5.3.3 Operation in shared spectrum

Clause 4 d) describes an asynchronous access. In this mode the TSCC remains inactive (in fact the physical channel remains de-keyed) until a MS activates the TSCC with a short burst. The MS then synchronizes to the forward control channel before making its random access service request.

## 5.4 CSBK/MBC/UDT Block Structure

CSBK/MBC/UDT PDUs may be sent by a TS on the outbound channel and MS on the inbound channel. In some instances it is necessary to send more information than can be accommodated in a single block CSBK PDU. In those cases multi-block PDUs of type MBC or UDT are transmitted. Multi-block PDUs shall use the following Data Type information elements (see TS 102 361-1 [5], clause 6.2):

- for PDUs except UDT, MBC Header and MBC Continuation are used;
- PDUs of type Data Header and Unconfirmed Data Continuation are used to transport information on the outbound channel and inbound channel for the Unified Data Transport (UDT) mechanism.

### 5.4.1 CSBK/MBC/UDT PDUs on the TSCC outbound channel

The PDUs sent by a TSCC on the outbound channel are classified as illustrated in figure 5.3.

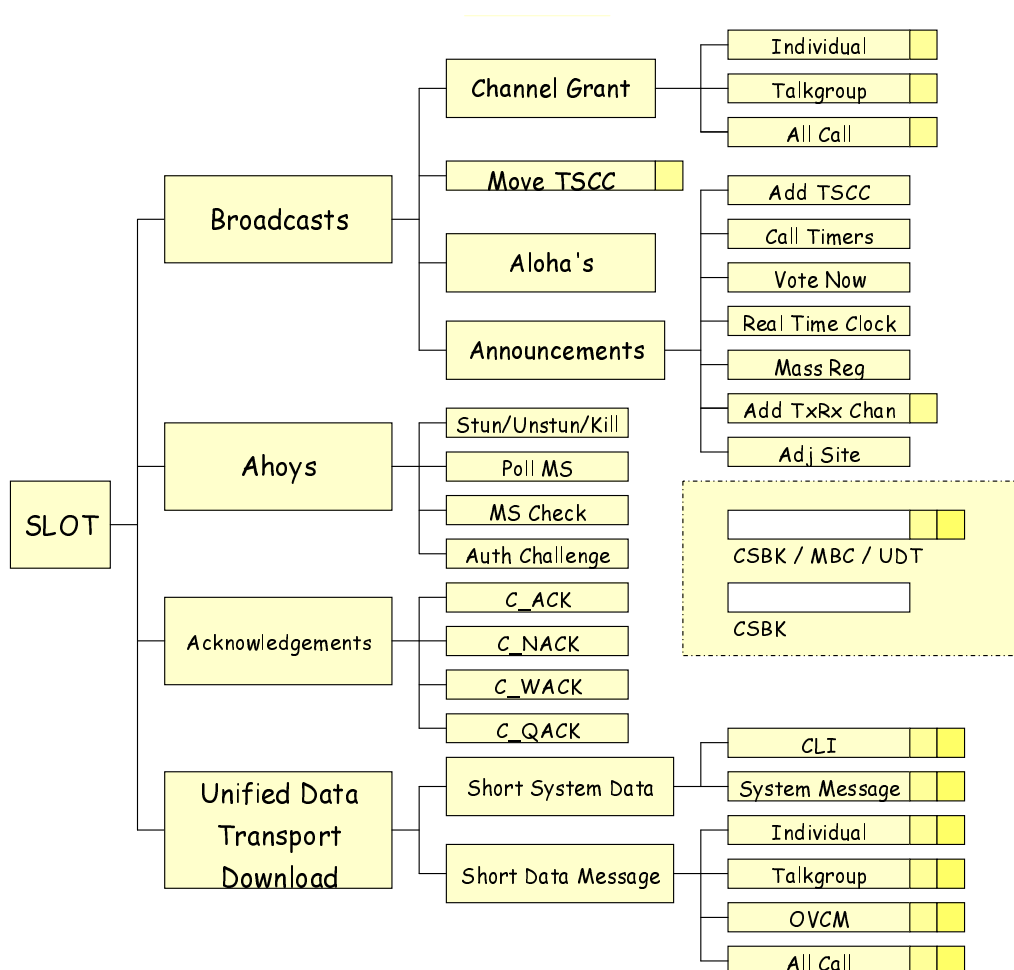

Figure 5.3: TSCC CSBK/MBC/UDT Outbound channel Structure

Table 5.1: TSCC CSBK/MBC/UDT Outbound channel PDUs

Class	Mnemonic	PDU Descriptor	Description
Broadcast	C_GRANT	Channel Grant	Transfer a call to the payload channel
	C_MOVE	Move to a new physical channel	MSs shall move to an alternative TSCC
	C_ALOHA	Aloha	To Manage Random Access
	C_BCAST	Announcements	PDUs intended for all MSs listening to this TSCC
Ahoys	C_AHOY	Ahoy	Sent to MS and demand a response
Acknowledgements	C_xACKD	Acknowledgements	A response to PDUs from the MS that demand a response: C_ACKD, C_NACKD, C_WACKD.C_QACKD
Unified Data Transport Outbound	C_UDTHD	Short System Message Outbound (see note)	System PDU addressed to an individually addressed MS and demand a response
		Short Data Message Outbound (see note)	UDT Short data message addressed to an individual MS or talkgroup
NOTE: C_UDTHD PDUs are made up of multiple blocks that consist of a UDT Header followed by 1 to 4 appended UDT data blocks - see annex B.			

### 5.4.2 CSBK/MBC/UDT PDUs on the TSCC inbound channel

The PDUs sent by a MS on the TSCC inbound channel are classified as illustrated in figure 5.4.

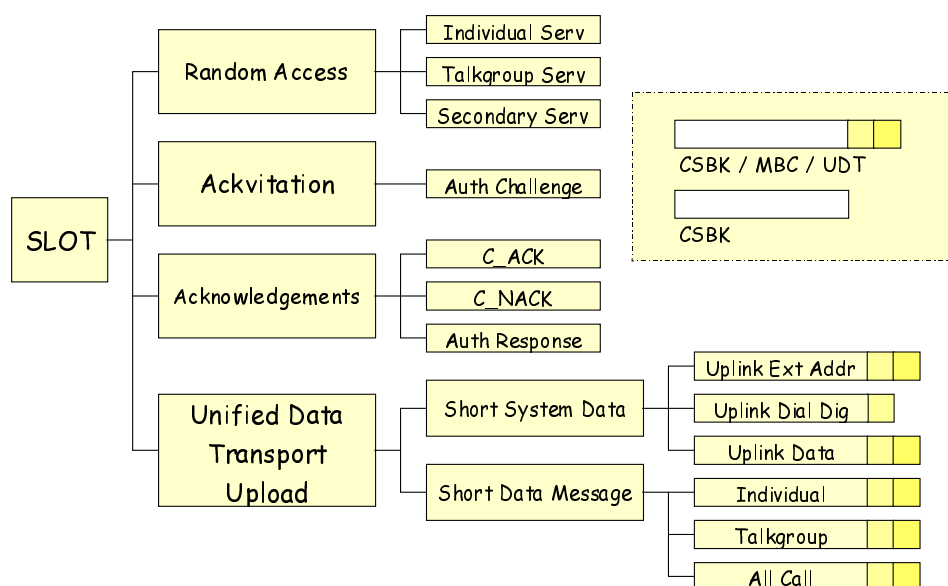

Figure 5.4: TSCC CSBK/MBC/UDT Inbound channel structure

Table 5.2: TSCC CSBK/MBC Inbound channel PDUs

Class	Mnemonic	PDU Descriptor	Description
Random Access	C_RAND	Random Access	Random Access Requests
Ackvitation	C_ACKVIT	Ackvitation	A response to PDUs that invite a further response
Acknowledgements	C_xACKU	Acknowledgements	A response to PDUs from the TSCC that demand a response C_ACKU, C_NACKU
Unified Data Transport Inbound	C_UDTHU	Short System Message Inbound	System PDU addressed to an individually addressed MS or the TSCC as a response to an Ahoy PDU from the TSCC
		Short Data Message Inbound	Short Data Message addressed to an individually addressed MS or the TSCC as a response to an Ahoy PDU from the TSCC

### 5.4.3 CSBK/MBC PDUs on the Payload Channel Outbound channel

The PDUs sent by a TSCC on the outbound channel are classified as illustrated in figure 5.5.

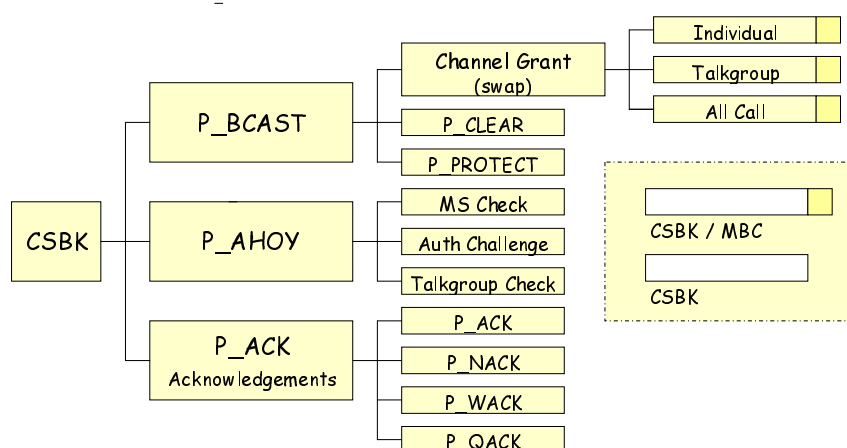

Figure 5.5: Payload CSBK Outbound channel Structure

Table 5.3: Payload CSBK Outbound channel PDUs

Class	Mnemonic	PDU Descriptor	Description
Broadcast	P_GRANT	Channel Grant (see note)	Swap a call to a new payload channel
	P_CLEAR	Payload Channel Clear	Clear the call from the payload channel
	P_PROTECT	Channel Protection	Access control
Ahoys	P_AHOY	Ahoy	Sent to MS and demand a response
Acknowledgements	P_xACKD	Acknowledgements	A response to PDUs from the MS that demand a response P_ACKD, P_NACKD, P_WACKD.P_QACKD
NOTE: A Channel Grant PDU is transmitted by the TS on a payload channel to swap an ongoing call to a new payload channel.			

## 5.4.4 CSBK PDUs on the Payload Channel Inbound channel

The PDUs sent by a MS on the Payload Channel inbound channel are classified as illustrated in figure 5.6.

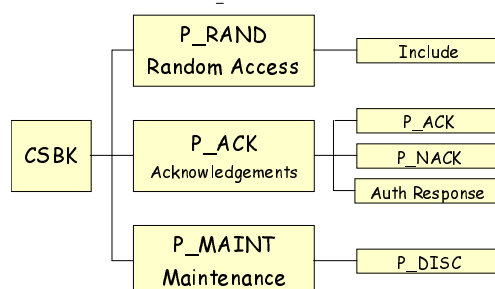

Figure 5.6: Payload CSBK Inbound channel Structure

Table 5.4: Payload CSBK Inbound channel PDUs

Class	Mnemonic	PDU Descriptor	Description
Random Access	P_RAND	Random Access	Random Access Requests
Acknowledgements	P_xACKU	Acknowledgements	A response to PDUs from the TS that demand a response P_ACKU, P_NACKU
Maintenance	P_MAINT	Call Maintenance PDUs	Disconnect

## 6 Trunking Procedures

### 6.1 Basic Structure

#### 6.1.1 Channel Structure

##### 6.1.1.1 Fully Regulated Structure

MS require a TSCC to regulate channel access. Therefore a TS shall incorporate one channel that is configured as a TSCC. A TS may support one additional TSCC within this protocol.

The TSCC shall provide the following facilities:

- management and control of channel access by MS using a random backoff mechanism;
- processing service requests to and from MS and optionally to and from line connected entities;
- allocating payload resources to calls;
- broadcast of system information to MS;
- MS location management by registration;
- provision of services such as UDT short data polling and transfer.

### 6.1.1.2 Shared Channel Unregulated Structure

MS access the channel for services using the basic channel access rules prescribed in TS 102 361-1 [5], clause 5.2.1. MS shall be permitted to transmit asynchronous "BS activation" signalling to the TS in accordance with the "BS activation" feature (described in TS 102 361-2 [6]). On becoming activated, the TS shall commence transmitting TSCC activity on the outbound channel, and the MS shall derive slot timing from this activity. When activated, the TSCC shall transmit PDUs inviting random access.

For Tier III, the outbound channel shall activate one TDMA channel as a TSCC and shall transmit Aloha and/or Broadcast PDUs in accordance with the random access procedures specified in the present document.

The TS shall maintain the timer T\_BS\_Inactive for each active inbound channel. The T\_BS\_Inactive timer runs when there is no activity on the inbound channel. If the T\_BS\_Inactive timer expires the TS shall transition to the Hibernating state in accordance with in TS 102 361-2 [6], clause G.2.1. Here the TS shall cease transmitting, which deactivates the outbound channel.

### 6.1.2 Physical Channel Addressing

The Tier III protocol supports a number of different physical channel strategies to accommodate operation in radio channels that may be dedicated, in blocks or allocated on an ad-hoc basis by an external agency. Physical radio channels may be specified by either:

- a) a logical channel plan whereby a transmitter and receiver frequency is mapped to a CHAN information elements. CHAN information elements permit up to 4 094 such logical / physical relationships; and/or
- b) a mechanism whereby the absolute transmitter and receiver frequencies are specified in the information elements of PDUs that are passed between DMR entities at the air interface.

For b) there will be a degradation in performance over a) because the information that shall be passed between entities is greater. However new physical/logical relationships that adds to or modifies the existing channel plan stored in MS may be broadcast on the TSCC.

Annex C provides an illustration how the logical channels may be mapped to physical frequencies.

### 6.1.3 Sub-Division of the MS population

Certain PDUs transmitted on the TSCC may be directed to and applicable only to a sub-set of the MS population. Examples are Aloha (C\_ALOHA) PDUs and Broadcast (C\_BCAST) PDUs. Applicable PDUs contain a 24 bit address information elements and a 5 bit (Mask) number information element. The sub-set division is achieved by using the address qualifier (Mask) from the PDU. This parameter instructs a MS to compare the "Mask" least significant bits of its individual address with the "Mask" least significant bits of the address field from the PDU (containing the MASK) to determine if that PDU is applicable.

A MS shall note the population subdivision contained in each applicable PDU that it receives. For Mask = 0 to 24, the PDU is applicable to the unit if the "Mask" least significant bits of the Aloha address match the "Mask" least significant bits of its individual address.

In this way, the MS population is effectively divided into  $2^{\text{Mask}}$  subsets:

- If Mask = 0 then no address bits are compared, so there is no subdivision.
- If Mask = 1 then only MS whose least significant individual address bit matches the least significant individual address bit from the PDU received shall consider the PDU to be applicable to that particular MS.

This process continues up to Mask = 24. In this case the PDU is only applicable to one MS.

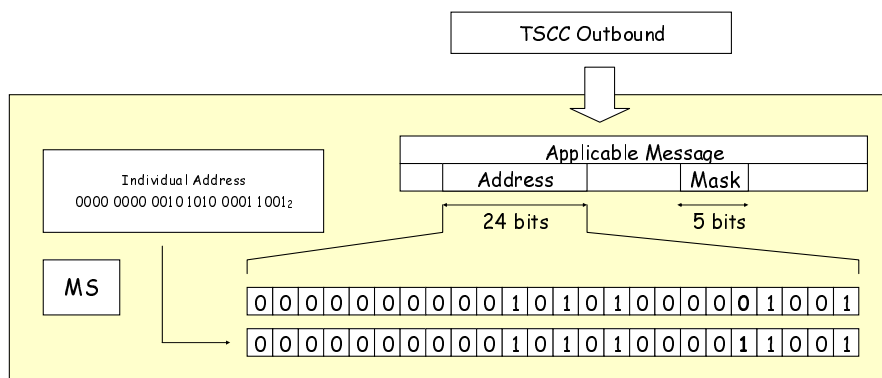

**Figure 6.1: Example of PDU containing the "Mask" information element**

Figure 6.1 illustrates a MS personalized with the address 0000 0000 0010 1010 0001 1001<sub>2</sub>.

A PDU is received that contains a Mask information element. The MS shall therefore determine if that PDU is applicable or the PDU shall be discarded.

EXAMPLE 1: The Mask information element contains the value 0 0100<sub>2</sub>.

The value of the Mask is 4 therefore the MS compares the 4 least significant bits of the address information element in the PDU received with the 4 least significant bits of the MS individual address.

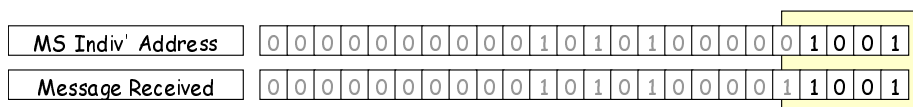

**Figure 6.2: Applicable PDU defined by Address and Mask**

The least significant 4 bits are compared as illustrated in figure 6.2. In this case the bits match so this IS an applicable PDU for this particular MS. (If Mask were any value from 0 to 4 the PDU would still be applicable.)

EXAMPLE 2: The Mask information element contains the value 0 0101<sub>2</sub>.

The value of the Mask is 5 therefore the MS compares the 5 least significant bits of the address information element in the PDU received with the 5 least significant bits of the MS individual address.

The least significant 5 bits are compared as illustrated in figure 6.3. In this case the bits do NOT match so this PDU shall be discarded by this particular MS. (If Mask were any value from 5 to 24 the PDU would still be discarded.):

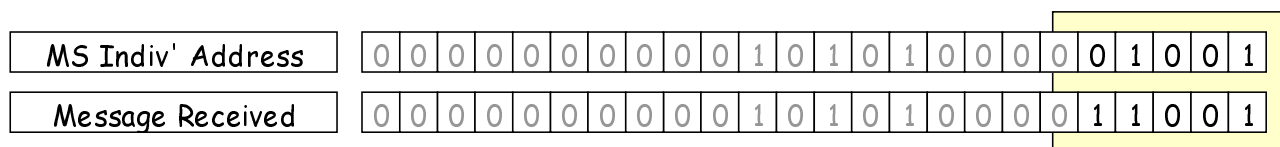

**Figure 6.3: Non-Applicable PDU defined by Address and Mask**

## 6.2 Random Access Procedures

These clauses define the random access protocol, which is based on slotted Aloha that is used to:

- control the collision of simultaneous random access attempts from different MSs;
- manage the TSCC to minimize access delays;
- ensure system stability; and
- maintain optimum throughput under heavy traffic loads.

Random access is the only access method permitted for MS on a fully regulated TSCC. For a Tier III system employing asynchronous access, and when the TSCC is de-keyed, the first random access attempt shall activate the physical TSCC channel whereupon the outbound burst shall regulate further signalling.

### 6.2.1 The Random Access Principle

The figures in the random access procedure clauses adopt the conventions illustrated in figure 6.4.



**Figure 6.4: Conventions used in the figures**

In addition, the TDMA-slot and TDMA-Frame is illustrated in figure 5.1.

PDU's transmitted on the TSCC on the outbound channel are divided between those that invite random access (such as Alohas) and those that withdraw one or more slots for the purpose of soliciting responses from MSs on the inbound channel (see clause 6.2.1.1.3).

#### 6.2.1.1 Random Access Control

The TSCC outbound channel creates an environment where TSCC access may be managed and controlled. This protocol specifies a specific C\_ALOHA PDU that contains the information elements Random-Backoff, Mask, and Service Function, to manage and control random access. Other PDU's transmitted on the TSCC also contain the random backoff information element.

All MS initiated services are by random access. If an MS wishes to make a random access attempt, the MS may send the random access service request PDU so long as:

- access is not inhibited by Mask (see clause 6.2.1.1.1); or
- access is not inhibited by the Service Function (see clause 6.2.1.1.2); or
- the slot chosen is not withdrawn (see clause 6.2.1.1.3).

##### 6.2.1.1.1 Sub dividing the MS population

C\_ALOHA PDU's contain an address information element and a Mask information element. The procedure described in clause 6.1.3 is therefore applied.

A MS shall note the population subdivision contained in each Aloha PDU that it receives. When attempting random access, the MS shall check if the population subdivision is applicable to it using the qualifier (Mask) and the address field from the Aloha PDU. For Mask = 0 to 24, the PDU is applicable to the MS if the "Mask" least significant bits of the Aloha address match the "Mask" least significant bits of its individual address.

The subdivision is applied to subsequent TDMA frames marked PDU's that do not contain the Mask information element, until updated or changed by the next Aloha PDU.



In this way, the MS population is effectively divided into  $2^{\text{Mask}}$  subsets:

- If Mask = 0 then no address bits are compared, so there is no subdivision (under normal traffic loading, this will usually be the case).
- If Mask = 1 then only units whose least significant individual address bit matches the Aloha address may send non-emergency random access PDUs. Thus the MS population has been divided into two subsets.
- This process continues up to Mask = 24. In this case only one MS shall be permitted to make a random access attempt. (unless the MS requested an emergency service whereupon the MS may make a random access attempt for all values of Mask except Mask = 24).

When a MS becomes active on a TSCC, including when returning from a payload channel, it shall either assume that the population is not subdivided (i.e. that the last C\_ALOHA PDU was applicable to all MSs) or wait for a C\_ALOHA PDU before attempting random access.

#### 6.2.1.1.2 Checking the Service-Function

For service requests except emergency:

- A MS shall use the Service Function from the C\_ALOHA PDU. A MS shall not choose a slot for random access unless the random access attempt is for a service type invited by the Service Function information element.

**Table 6.1: Service-Function**

Value	Remark
00 <sub>2</sub>	Random Access invited for all Services
01 <sub>2</sub>	Random Access Invited for Services that require a physical payload channel Random Access Invited for registration requests
10 <sub>2</sub>	Random Access Invited for Services that do not require a physical payload channel Random Access Invited for registration requests
11 <sub>2</sub>	Random Access invited for random access registration requests only

- The Service function shall apply until the Service-Function is updated by a subsequent C\_ALOHA PDU.

For emergency service requests the MS is not required to check the Service-Function.

#### 6.2.1.1.3 Withdrawing slots from Random-Access

The TSCC may transmit a PDU (consisting of single block CSBK, multi block MBCs or multi-block UDTs) on the outbound channel that solicits a response from a specified MS. The MS response shall be sent in the next TDMA-frame following the last block of the TSCC PDU. In order to prevent a collision occurring between this solicited response and a random access transmission, the TSCC withdraws this timeslot, thereby prohibiting any random access transmissions in the given timeslot. The protocol makes use of the AT bit transmitted in the CACH to indicate to all MS that the following slot is withdrawn (see TS 102 361-1 [5], clause 4.5). (This, therefore implies that an MS intending to transmit a PDU by random access in a given timeslot shall successfully decode the appropriate CACH and note the value of the AT bit to ensure that the chosen timeslot has not been withdrawn from random access.)

In the following example in figure 6.5, when the TSCC transmits a PDU that requires a response, that PDU withdraws the following TDMA frame (slot but one).

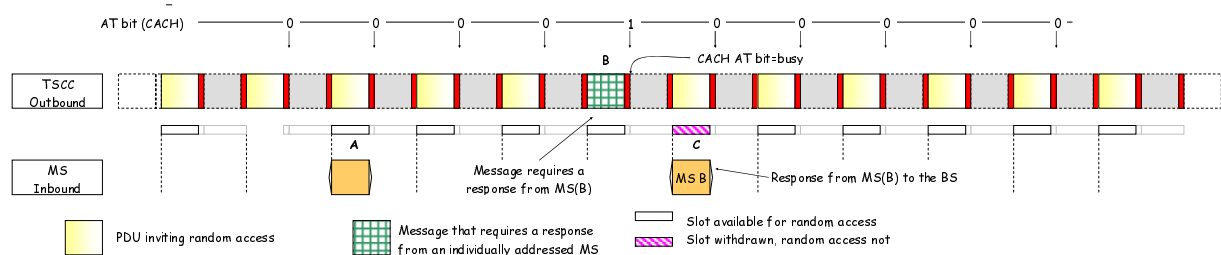

**Figure 6.5: Withdrawn Slots Example**

The TSCC transmits PDUs inviting random access:

- Aloha PDUs (see NOTE) invite random access. Therefore an MS is permitted to transmit a random access PDU. The CACH following each of the Aloha PDUs sets the AT bit to 0<sub>2</sub>. Aloha PDUs never withdraw slots but an Aloha PDU with Mask=24, MS address=NULL, shall specifically prohibit random access even though the slot is not withdrawn;
- TSCC transmits a PDU that demands a response followed by the CACH with the AT bit set. The result is that the following slot but one at "C" is withdrawn - i.e. not available for random access. The TSCC withdraws that slot because the PDU "B" requires response from a specific MS(B);
- MS(B) transmits its acknowledgment PDU;
- if the slot chosen for the random access attempt is not available because the slot is withdrawn, the MS shall choose another slot for a subsequent random access attempt using the random backoff procedures specified in clause 6.2.1.1.6.

NOTE: Other PDUs also invite random access.

#### 6.2.1.1.4 TSCC responses to Random Access attempts

After receiving a random access PDU, the TSCC shall send a response. Valid responses are specified in the clauses detailing the registration and call procedures. The response may be sent in the TDMA-frame following the random access PDU or it may be delayed. The TSCC shall use a NRand\_Wait information element in the most recent C\_ALOHA PDU to specify the delay (in TDMA-frames) a MS shall wait before choosing another slot using a random backoff timer for a repeat random access attempt.

#### 6.2.1.1.5 Noting the response delay

An MS shall note the delay parameter NRand\_Wait from each C\_ALOHA PDU it receives and shall use table 6.2 below to derive from it the number of TDMA-frames, Nwait, by which the TSCCs response to a random access PDU may be delayed. (NWait = 0 means that the response is expected by the MS in the TDMA-frame following the random access PDU.) At the start of a session, until it receives an Aloha PDU, the unit shall assume a default value of NWait = NDefault\_NW.

**Table 6.2: System Response delays indicated by the delay parameter NRand\_Wait**

NRand_Wait	Nwait(TDMA-frames)	NRand_Wait	Nwait(TDMA-frames)
0	0	8	8
1	1	9	9
2	2	10	10
3	3	11	11
4	4	12	12
5	5	13	13
6	6	14	15
7	7	15	24

### 6.2.1.1.6 Random Backoff

This clause specifies the method to manage the TSCCs receipt of random access PDUs. A system periodically broadcasts a random back-off timer (specified in TDMA frames).

When a MS initiates a call, the MS may send its first random access PDU in the next slot (subject to Mask, Service Function and withdrawn slot specified in clauses 6.2.1.1 a), b) and c)).

The MS shall invoke the random backoff procedures specified in this clause if:

- the MS could not make its random access attempt because access was inhibited by Mask;
- the MS could not make its random access attempt because access was inhibited by the Service Function;
- the MS could not make its random access attempt because the slot was withdrawn;
- the MS did make a random access attempt but that attempt was unsuccessful (the TSCC did not respond before the expiry of Nrand\_Wait).

If the MS makes a random access attempt and is unsuccessful, the MS shall choose a slot for its next random access attempt by choosing a random number between the limits of one and the backoff parameter using a statistically uniform distribution.

Figure 6.6 shows a TSCC using parameters NRand\_Wait=0. The most recent value of back-off received=4.

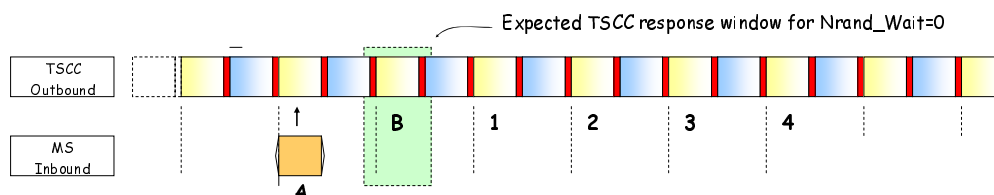

**Figure 6.6: Random Backoff Example #1**

- at [A] the MS makes a random access attempt. NRand\_Wait=0 indicates that the TSCC will respond in the next TDMA frame at [B];
- after TDMA frame [B] a response has not been received, therefore the MS chooses one of the slots 1, 2, 3, 4 randomly for its next access attempt.

Figure 6.7 shows a TSCC using parameters NRand\_Wait=1. The most recent value of back-off received=4.

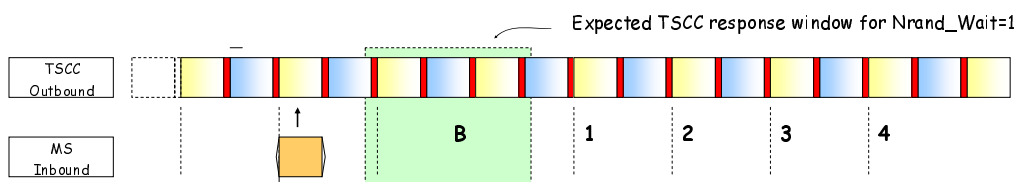

**Figure 6.7: Random backoff Example #2**

- the MS makes a random access attempt. NRand\_Wait=1 indicates that the TSCC will respond in one of the next two TDMA frames at [B];
- after TDMA frame [B] a response has not been received, therefore the MS chooses one of the slots 1, 2, 3, 4 randomly for its next access attempt.

A number of outbound channel PDUs including an Aloha PDU contain the backoff information element.

NOTE: Future releases of the standard may define CACH messages that contain this information element.

The backoff may be altered by the TSCC and broadcast to MS to respond to varying load conditions presented to the system throughout the course of operation. If the system has a light traffic load, the backoff may be small, so decreasing random access latency. If the traffic load increases a longer backoff may be warranted to spread competing of random access attempts from different MSs by the TSCC transmitting a larger backoff number. This traffic load may be estimated from historical usage or may be calculated from the burst traffic being received at that time.

The backoff parameter may change while the MS is already making random access attempts. When the MS has chosen a random slot, that slot shall be preserved for the duration of the current random access attempt. Any new value of backoff parameter from the TSCC shall be noted by the MS and shall be employed if the MS needs to choose a new random slot for its next random access attempt.

For PDUs that contain the backoff information element, the number of backoff TDMA-frames is coded, so that more backoff TDMA-frames can be realized than a pure binary representation would permit. The explicit numbers of TDMA-frames resulting from the back-off number is indicated by table 6.3.

**Table 6.3: Number of backoff TDMA frames indicated by the Backoff Number**

Backoff Number	Back-off TDMA Frames	Backoff Number	Back-off TDMA Frames
0	Reserved	8	15
1	1	9	20
2	2	10	26
3	3	11	33
4	4	12	41
5	5	13	50
6	8	14	70
7	11	15	100

Note that:

- a) a C\_ALOHA PDU with M=24 invites access only for one specific individual MS;
- b) in the example in figure 6.5, if an MS had chosen the slot "C" for a random access attempt, that MS would be able to determine that the slot was not available for random access because the slot was withdrawn by decoding the AT bit from the CACH and noting that the slot the MS had chosen was withdrawn. The MS would abandon that random access attempt, and choose another candidate slot using the random backoff parameter;
- c) the MS shall rely on the AT bit to determine if the following random-access slot is withdrawn. If the MS does not successfully receive the preceding AT bit, the MS shall assume the slot is withdrawn.

#### 6.2.1.1.7 Retry decision and time-outs

After sending a random access PDU, a MS shall wait to receive a response from the TSCC. Various PDUs shall be accepted as a valid response (as specified in the clauses detailing the registration and call procedures).

The MS shall abandon its access attempt if it has sent the maximum permitted number of random access for the particular service requested and received no valid response. This number depends on the service and priority of service being requested:

- For non-emergency random access requests, it is N<sub>Rand\_NR</sub>.
- For emergency random access requests, it is N<sub>Rand\_NE</sub>.

The MS shall also operate a time-out T<sub>Rand\_TC</sub> that defines the maximum time it waits trying to achieve random access, and abandon the attempt if this time-out expires.

If the unit's access attempt fails as a result of T<sub>Rand\_TC</sub> timeout then:

- a) if the MS has not transmitted a PDU, it shall return to the idle state (and may indicate the failure to the user);
- b) otherwise, (the MS has made at least one random access attempt) if the T<sub>Rand\_TC</sub> timer expires while the MS is waiting N<sub>wait</sub>+1 for the last random access attempt, the MS will complete the N<sub>wait</sub>+1 TDMA-frames before abandoning its random access.

6.2.1.1.8 Random Access (non-emergency) SDL for a MS as defined in clause 6.2

Figures 6.8 to 6.10 illustrate the non-emergency random access procedures SDL.

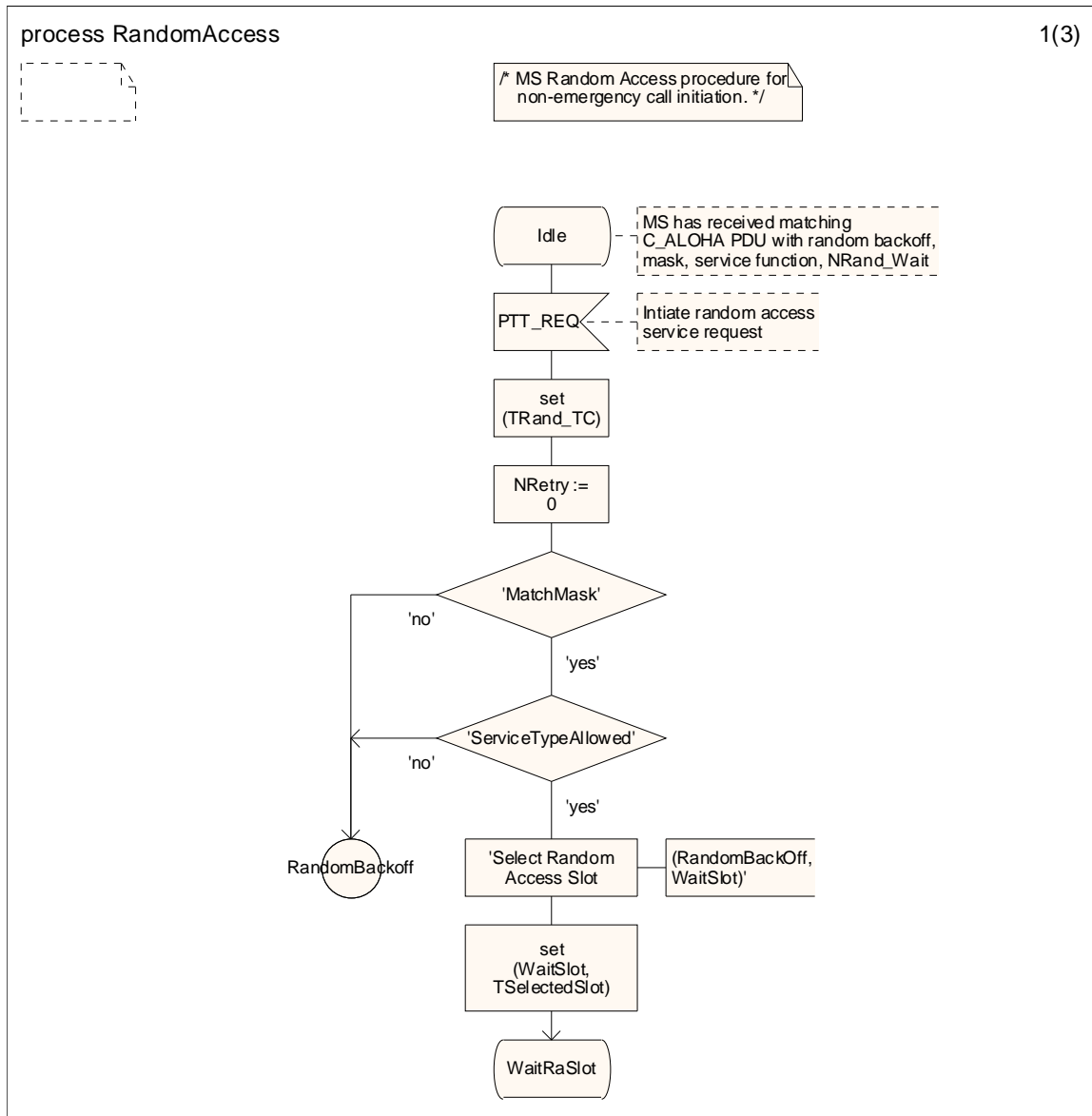

Figure 6.8 (sheet 1 of 3): Random Access Procedure SDL

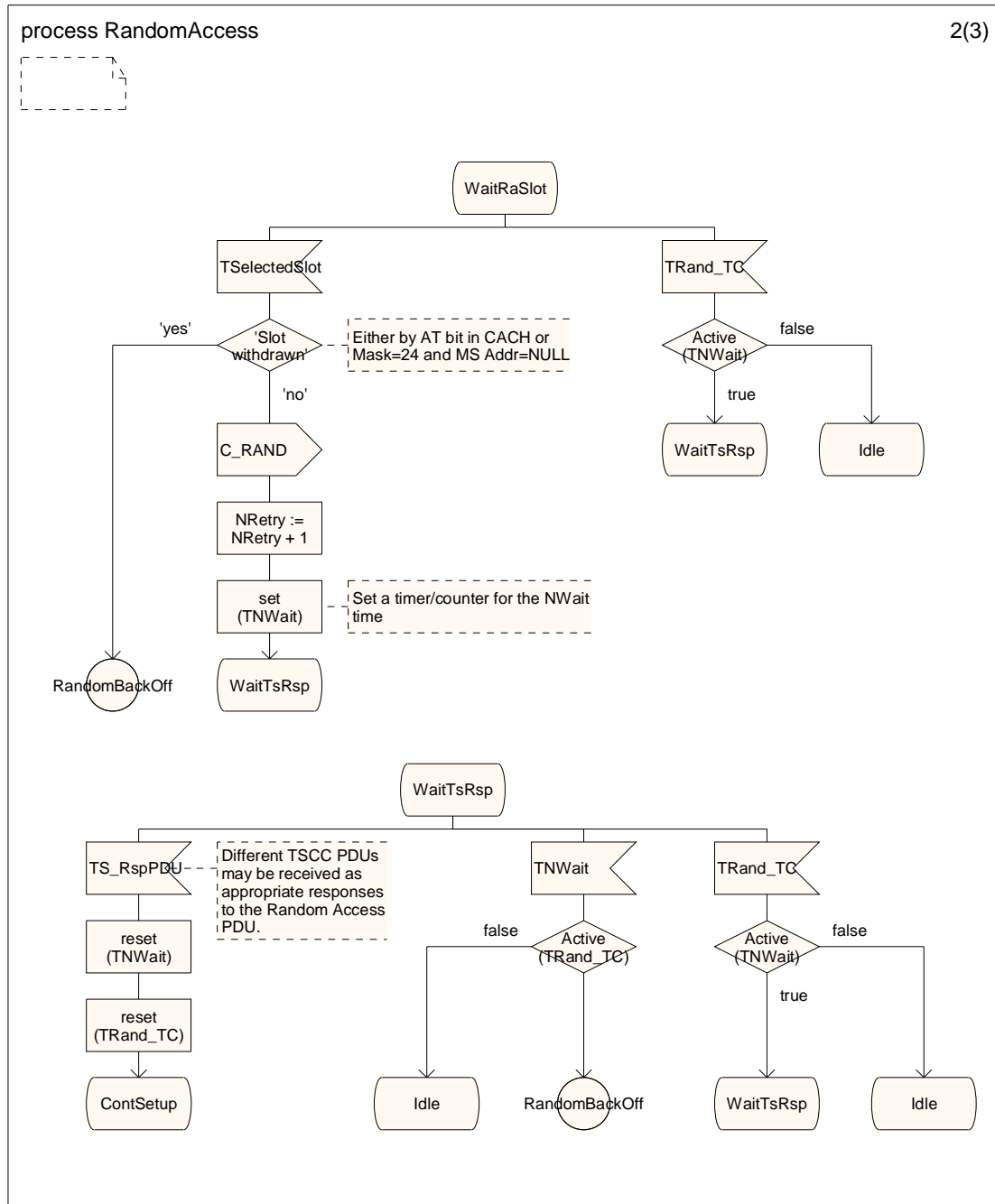

Figure 6.9 (sheet 2 of 3): Random Access Procedure SDL

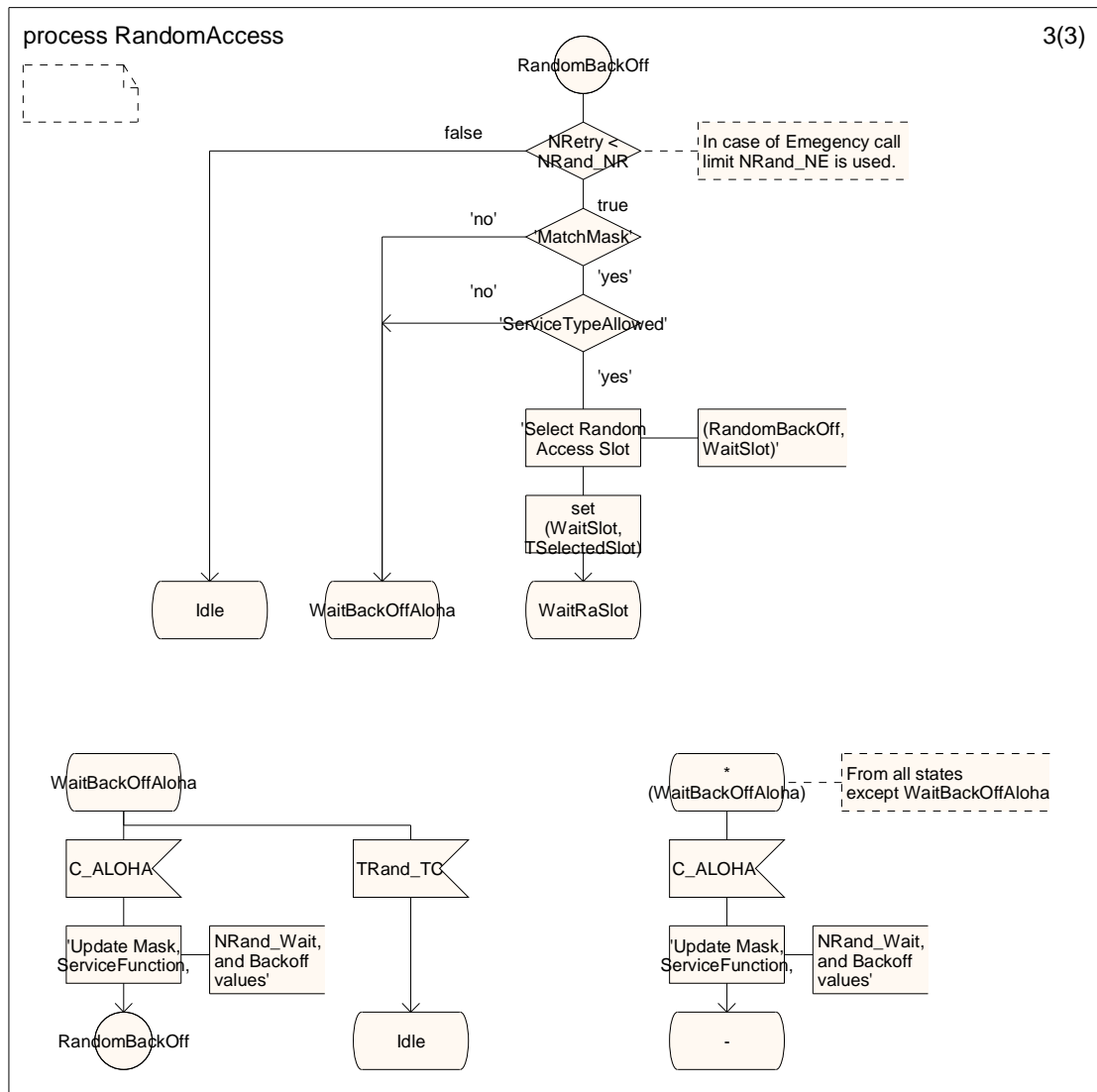

Figure 6.10 (sheet 3 of 3): Random Access Procedure SDL

6.2.1.1.9 Random Access (emergency) SDL for a MS as defined in clause 6.2

Figures 6.11 to 6.13 illustrate the emergency random access procedures SDL.

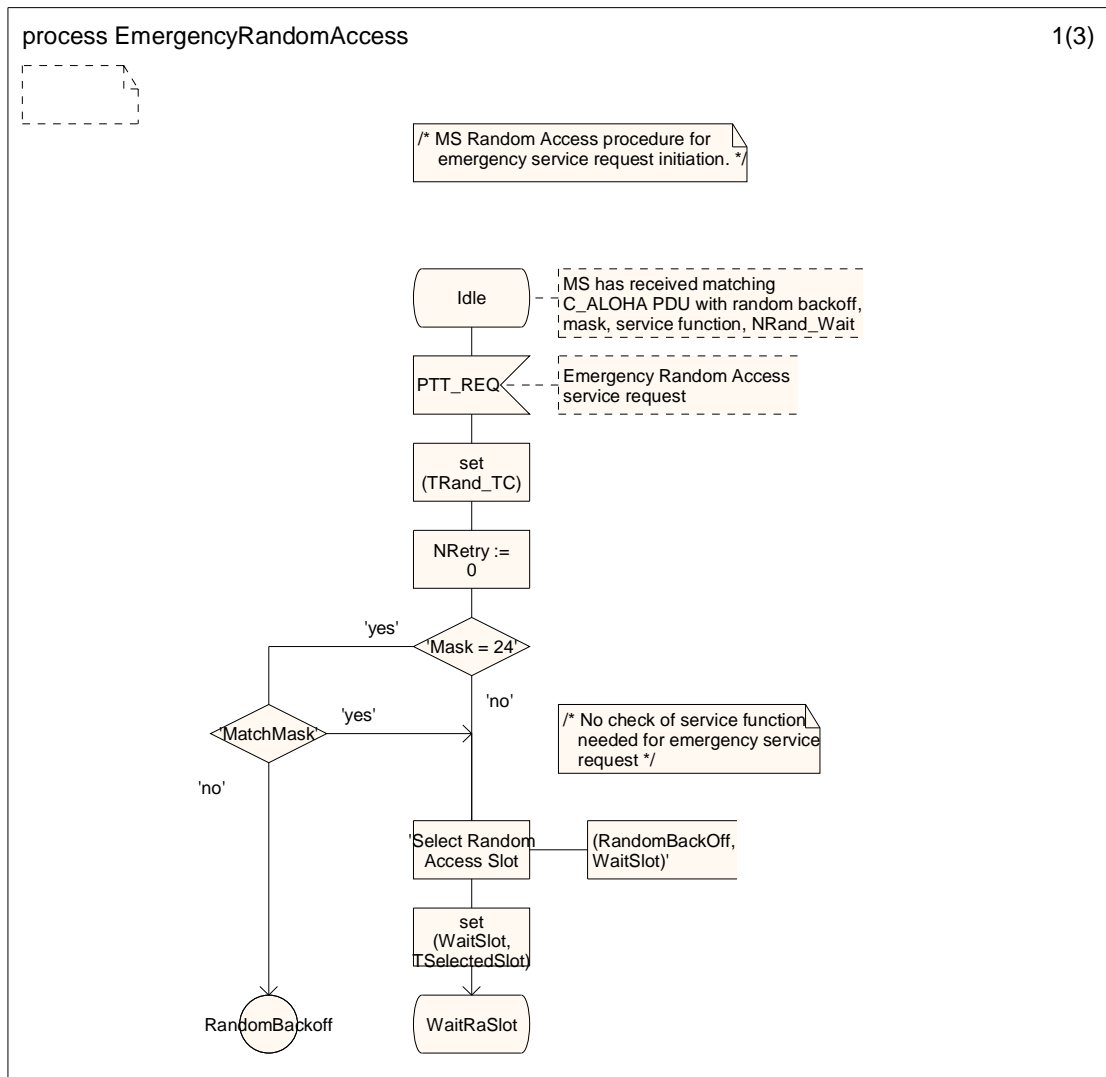

Figure 6.11 (sheet 1 of 3): Emergency Random Access Procedure SDL



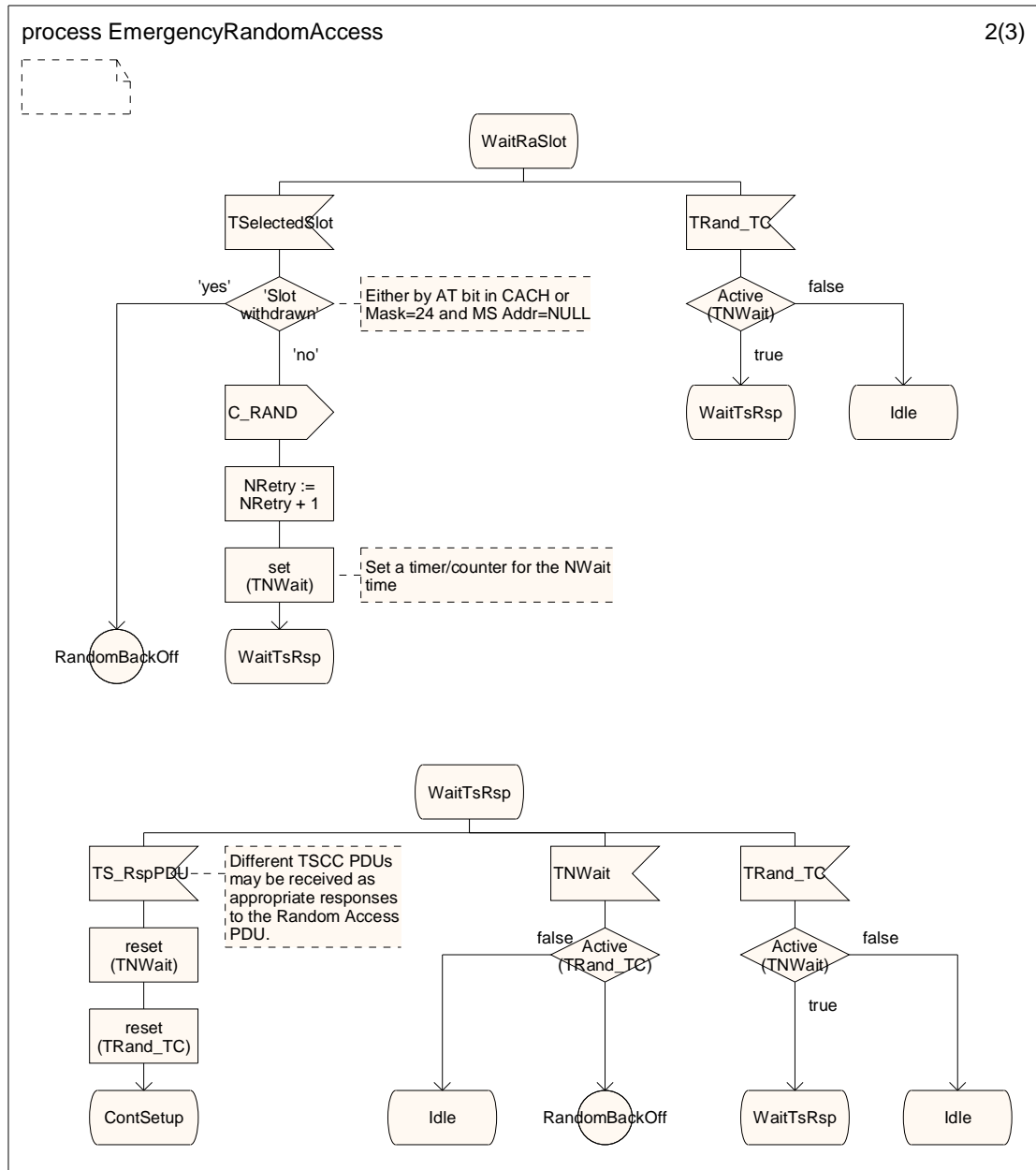

Figure 6.12 (sheet 2 of 3): Emergency Random Access Procedure SDL

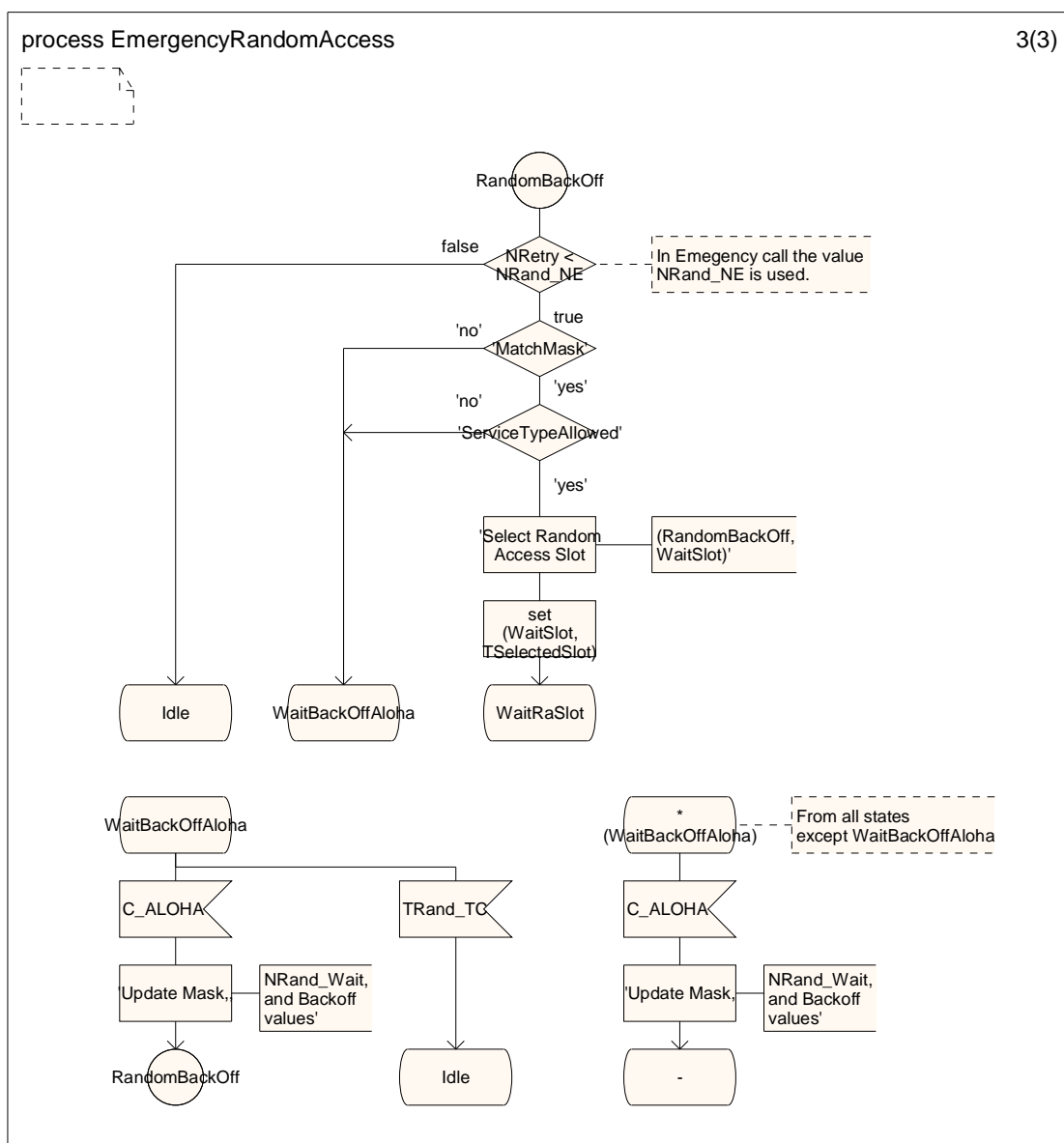

Figure 6.13 (sheet 3 of 3): Emergency Random Access Procedure SDL

### 6.2.1.2 Action after receiving an acknowledgement

The MS shall not re-transmit any further random access PDU when an appropriate acknowledgement has been received from the TSCC. Various PDUs that are acceptable in addition to specific acknowledgement PDUs are indicated in the procedures specified in the present document. An applicable TSCC response to a random access request shall start an MS timer. This timer may be restarted by the reception of a further applicable acknowledgement PDU from the TSCC. Two values are specified for this timer. One value **TP\_Timer** shall be used if the random access service requires a payload channel (for example a speech or packet data service). The second value **TNP\_Timer** shall be used for services that only use the TSCC (for example Registration, Short Data service).

### 6.2.1.3 MS Arriving on a Control Channel

Channel access regulation for trunked systems is implemented by a TSCC transmitting signalling on the outbound channel with periodic PDUs that define regulated channel access.

When an MS tunes to a new channel where the recent history of channel activity is unknown, the MS shall establish that the TSCC is identified as one that the MS is permitted to access:

- a) The MS shall first wait until it receives a colour code information element. If the colour code being transmitted by the TSCC is 0000<sub>2</sub> the MS shall skip the colour code check and check the C\_SYSCode as specified in clause 6.2.1.3 b). If the colour code being transmitted by the TSCC is a value other than 0000<sub>2</sub> the MS shall check that this particular channel is transmitting a colour code that is expected by the MS. The MS may maintain a list of logical channel numbers and their corresponding colour code assignments (see annex C).
- b) The MS shall wait until it explicitly receives the C\_SYSCode being transmitted on the TSCC. If the MS is authorized to access this TSCC, the MS shall wait for an applicable C\_ALOHA PDU before it attempts access by random access procedures defined in these clauses.

## 6.3 Control Channel Acquisition and Retention

Unless assigned to a payload channel (including immediately after switch-on), the MS shall attempt to find a TSCC appropriate to the MSs selected network. The search for a TSCC may be performed by a general hunt through all likely channels or by reference to parameters stored within the MS. A framework for MS hunting is described in annex D.

A MS shall not make any transmissions on a TSCC unless it is active on that channel. It shall not become active until it has received a C\_SYSCode that authorizes the MS to access that TSCC.

If an MS is hunting over a number of candidate channels, it shall leave the selected channel as soon as it becomes evident that the MS shall not be permitted service.

The discipline for MSs whilst active a TSCC and the circumstances which may result in a search for a new TSCC are the subjects of clause 6.3.2 Control Channel Acquisition Procedures.

In particular:

- the method by which the MS searches for an appropriate TSCC;
- the criteria to which a TSCC shall be considered appropriate by the MS - authorization;
- procedures for returning to the TSCC acquisition procedures.

The methods specified in this clause recognize that designers of networks may choose from a variety of control channel strategies, including both Dedicated Control Channels and Non-dedicated Control Channels.

These methods may result in the MS encountering a variety of control channel situations, including:

- a) receiving a TSCC which suffers short-term interruptions (radio fading and multi-path reception);
- b) suffering long-term interruptions to TSCC reception during which no appropriate TSCC can be received by the MS (Non-dedicated Control Channels, or moving out of range of the network);
- c) being in a location where it is possible for more than one TSCC to be received from the selected network, involving the unit in a choice;
- d) being instructed to leave a TSCC;
- e) being instructed to leave or being barred from access to, a TSCC as a result of a network load sharing arrangement;
- f) being instructed to sample an alternative TSCC on an adjacent radio site (Vote Now).

NOTE: It should be noted that a Non-dedicated Control Channel strategy may only be suitable for small single site trunked networks using only a few physical channels. If a multi-site trunked network employed a site with a non-dedicated TSCC, the network may find it impossible to connect a wide area call or transport services that only used the TSCC for delivery.

Procedures have been specified in the present document to indicate to MS when they may sample an adjacent site for a TSCC that may provide an improved grade of service for the MS user. This is achieved on the TSCC transmitting a PDU that invites all MS to leave the TSCC momentarily. During this sample time the TSCC can discontinue call transactions. Notwithstanding this, manufacturers may devise their own procedures that will allow a MS to leave the current TSCC to sample for an alternative TSCC. However it shall be noted that if the MS leaves the TSCC on its own volition the MS may miss a TSCC transaction.

### 6.3.1 MS Parameter Volatility

In order to satisfy the procedures specified in this clause, the MS shall retain certain parameters for each selected network when the MS is switched off. Other parameters shall be discarded when the MS is switched off. Table 6.4 lists the behaviour of each applicable parameter. MS parameters that are not listed in table 6.4 shall assume that it shall be discarded when the MS is switched off.

**Table 6.4: MS Parameter Volatility for Control Channel Acquisition and Retention**

Parameter	Clause	Fixed during MS Personalization. Retained when MS is switched off	Changes during operation and retained when MS is switched off	Changes during operation and discarded when MS is switched off
MODEL	6.3.2.2.1.1	X		
NET	6.3.2.2.1.1	X		
DMRLA	6.3.2.2.1.1	X		
MS Category	6.3.2.2.1.3	X		
Acquisition Authorization Data	6.3.2.2.2	X See note		
Logical Channel Hunt List	Also see annex C	X		
Additions to the hunt list from Announcements received	7.2.19.1		X	
Any parameter not listed				X

NOTE: Length of authorization data is dependent on MODEL. Huge - 10 bits, Large - 8 bits, Small - 5 bits, Tiny - 3 bits.

### 6.3.2 Control Channel Acquisition Procedures

Control Channel (TSCC) acquisition consists of the steps of checking the C\_SYSCode (verification) and, if successful measuring the signal quality (confirmation) as illustrated in figure 6.14.

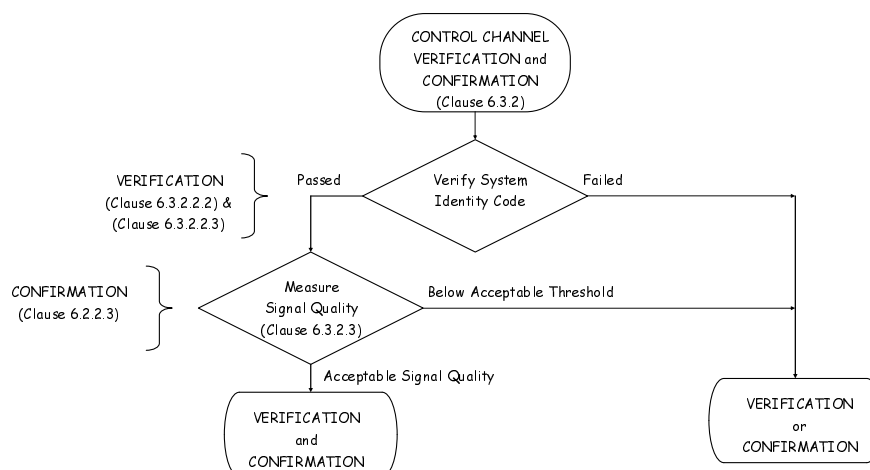

**Figure 6.14: Verification and Confirmation Steps**

### 6.3.2.1 Entry into TSCC Acquisition Procedures

The TSCC acquisition procedures enable a MS that is not assigned to a payload physical channel to attempt to select a TSCC. TSCC acquisition is a procedure that consists of hunting for candidate TSCCs and attempting to verify that the MS is authorized to become active on that selected TSCC.

The MS shall enter into the TSCC acquisition procedures under the following circumstances:

- a) immediately after switch-on;
- b) a user-initiated change of selected network;
- c) when it has relinquished the current TSCC under the procedures specified in clause 6.3.3;
- d) when it has received an applicable P\_CLEAR PDU on a payload channel;
- e) when it has sent disconnect PDUs P\_MAINT(Maint\_Kind=DISCON) or timed-out on a payload physical channel;
- f) when it has received a call P\_AHOY(Service\_Kind=1111<sub>2</sub> Cancel Call Service) PDU on a payload physical channel which requires it to vacate that physical channel.

At all times during the TSCC acquisition procedures the MS shall mute its received audio and transmission shall be inhibited.

A framework for TSCC control channel hunting is provided in annex D.

### 6.3.2.2 Identifying a Candidate Control Channel

When an MS is searching for a suitable control channel, the MS shall examine any signal detected for conformity with TSCC structure. The MS shall accept as a candidate TSCC any channel on which a TSCC synchronization sequence is detected.

The method by which the MS identifies candidate TSCCs during hunting is not detailed in the present document. In particular no maximum time allowance for this procedure is specified, although attention is drawn to the necessity of completing tests as quickly as possible, notably on channels which can be easily rejected as TSCC candidates (e.g. invalid parameters from the C\_SYSCode), since the overall speed of the hunt (and thus efficiency of service to the user) depends on the rapidity with which these tests can be carried out.

#### 6.3.2.2.1 Checking the System Identity Code

When the MS has identified a candidate TSCC, it shall examine the values of the C\_SYSCode fields from the TSCC PDUs that transmit the C\_SYSCode information element.

The time which the MS may continue to search for a value of C\_SYSCode information element for verification is not specified since this depends on the regularity by which the TSCC transmits PDUs that contain the C\_SYSCode information element. However it should be noted that the essential C\_SYSCode parameters for TSCC searches are also transmitted in the CACH.

When the MS has selected a C\_SYSCode information element for verification, it shall decide if it is authorized to acquire the TSCC (see clause 6.3.2.2.2). If acquisition is permitted then the MS shall become active on that TSCC and start the signal quality checking procedures specified in clause 6.3.2.3.

Whilst active on a TSCC, after verification but prior to confirmation, the MS shall not transmit any random access PDUs, but it shall comply with any applicable PDUs received, as required, provided that to do so does not involve transmitting on the TSCC.

##### 6.3.2.2.1.1 Structure of the System Identity Code (C\_SYSCode)

DMR trunked networks may range from tiny systems consisting of a very small number of sites to very large systems covering a wide geographic area. To accommodate this wide range of networks, DMR specifies four network models, each with characteristics appropriate to each model.

Table 6.5: Network Model

Network Model	Model Coding	Number of Networks	Number of Sites per Network	DMRLA
Tiny	00 <sub>2</sub>	512	8	0 to 3
Small	01 <sub>2</sub>	128	32	0 to 5
Large	10 <sub>2</sub>	16	256	0 to 8
Huge	11 <sub>2</sub>	4	1 024	0 to 10

In order to identify the network and site to MSs, a TSCC frequently transmits a C\_SYSCode. MSs shall examine the C\_SYSCode to determine if they are permitted to become or remain active on the TSCC. The C\_SYSCode information elements are structured as follows.

Table 6.6: Network Model Description

Parameter	Descriptor and section	Description
MODEL	Network Model	Tiny, Small, Large, Huge
NET	Network Identity	Identifies a particular DMR trunked network
SITE		The SITE parameter identifies a particular site within a network
PAR		for multiple TSCCs within one TS (site)

A bit specific representation of the Syscode information element is illustrated in figure 6.15. The MODEL defines the length of the NET and SITE information elements. Table 6.5 shows the effect of this partition. It is likely that in a particular geographical area a large number of small networks may be employed but only a small number of large networks. The MODEL parameter enables a number of differing archetypal networks to be defined.

NOTE: The DMRLA parameter illustrated in figure 6.15 is used for registration. The registration protocol is specified in clause 6.4.4).

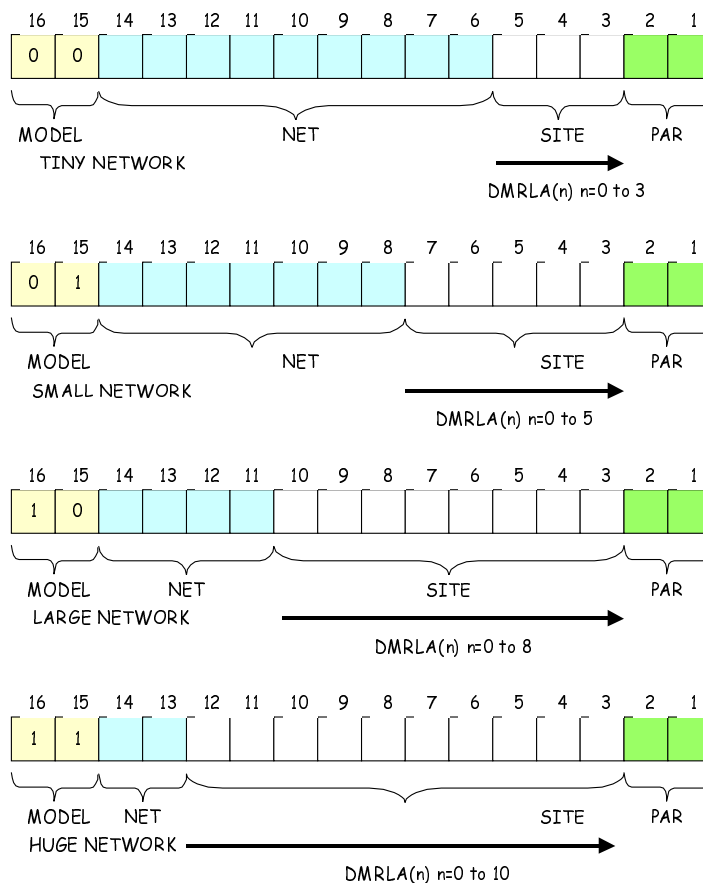

Figure 6.15: Allocation of NET and SITE information elements in C\_SYSCode

### 6.3.2.2.1.2 Multiple Control Channels

DMR trunked networks may operate with one or two TSCCs at a single site. The site may sub-divide the MS population to allow load sharing between TSCCs. This facility is provided by the PAR sub-field in the C\_SYSCode and by control categorization of MSs.

### 6.3.2.2.1.3 Control Categorization of Radio Units

At the time of MS network personalization, the MS shall be allocated a control category (ContCAT) stored in the MSs fixed non-volatile storage. Two control categories are available, which are designated A and B.

The control category governs acquisition and retention of a TSCC, since the PAR sub-field in the C\_SYSCode indicates which MS control categories are allowed to become active.

### 6.3.2.2.1.4 The PAR Sub-field

The PAR information element occupies two bits of the C\_SYSCode. The meanings assigned to the four possible values of PAR shall be:

- 00<sub>2</sub> Reserved.
- 01<sub>2</sub> Category A MSs only permitted.
- 10<sub>2</sub> Category B MSs only permitted.
- 11<sub>2</sub> Category A MSs and B MSs permitted.

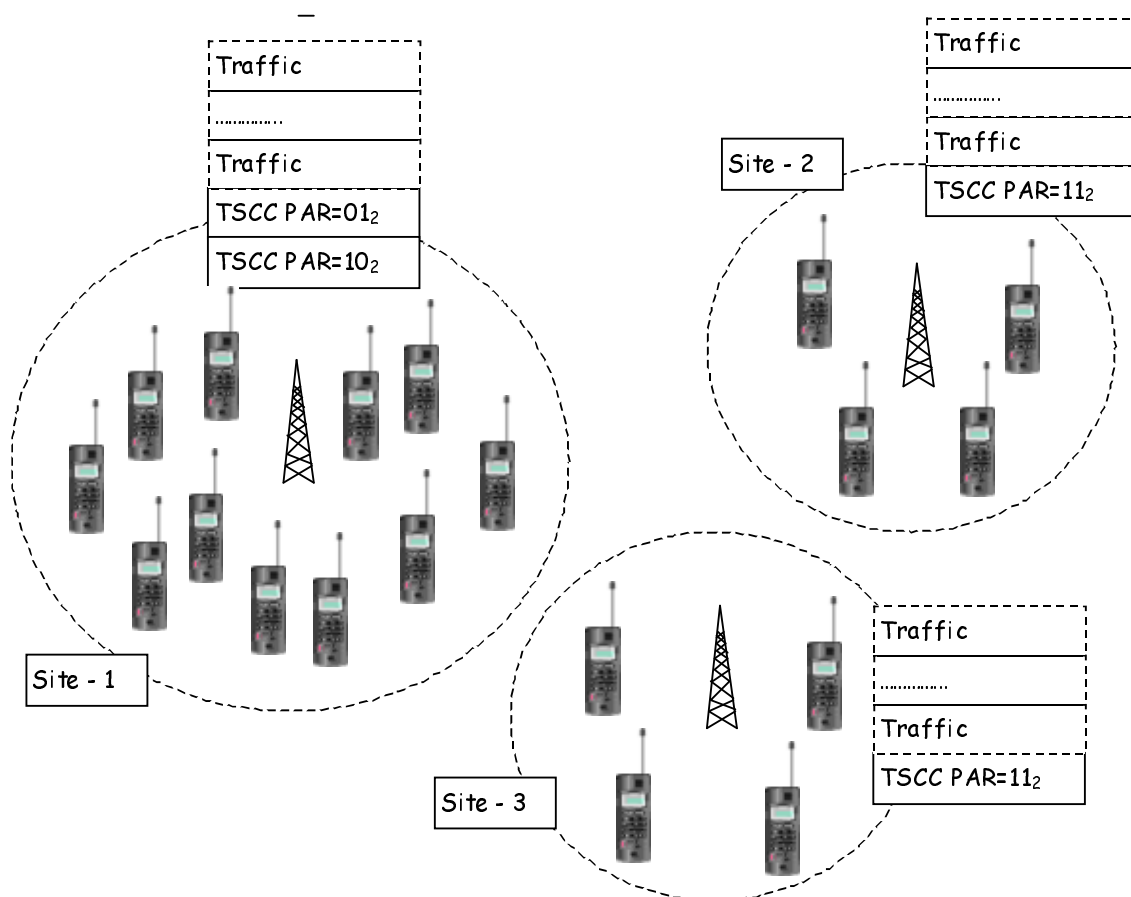

Figure 6.16: Multiple Control Channels by PAR

**EXAMPLE:** A wide area DMR trunked network has a number of radio sites that employ one TSCC and one site that is equipped with two TSCCs. Differing fleets of MS are personalized such that the total MS population is evenly distributed between Category A and Category B units. Referring to figure 6.16, Site '1' is configured with two TSCCs and radiates PAR=01 on the first TSCC and PAR=10 in the second TSCC. Any MS, whether Category A or B can become active on the TSCC from site 2 and site 3. When MS travel to site 1 however they will cluster on their appropriate TSCC.

#### 6.3.2.2.2 TSCC Authorization Procedure

The MS shall read the C\_SYSCode being transmitted on the TSCC:

- a) Checking the MODEL:
  - The MS shall compare the MODEL transmitted in the C\_SYSCode on the TSCC with the MODEL stored in MS fixed non-volatile storage. If there is no match then the MS unit shall assume that it is not authorized to acquire the TSCC under test.
- b) Checking the NET:
  - If the MS has successfully verified a) above then:
    - The MS shall compare the NET transmitted in the SYS code on the TSCC with the NET stored in MS fixed non-volatile storage. If there is no match then the MS unit shall assume that it is not authorized to acquire the TSCC under test.
- c) Checking the SITE\_Acquisition Authorization Data:
  - If the MS has successfully verified a) and b) above then:
    - The MS shall first check if it has stored any SITE acquisition authorization parameters. If no SITE acquisition authorization parameters are stored then no checking of SITE acquisition authorization shall be performed. However if the MS holds at least one parameter, each value stored shall be compared with the SITE parameter transmitted in the C\_SYSCode on the TSCC. If there are no matches then the MS unit shall assume that it is not authorized to acquire the TSCC under test.
- d) Checking the PAR sub-field:
  - If the MS has successfully verified a), b) and c) above then it shall examine the PAR sub-field in the light of its control category held in fixed non-volatile storage. If the control category of the MS is not one of the categories permitted access by the PAR sub-field value, then the MS shall assume that it is not authorized to acquire the TSCC under test.



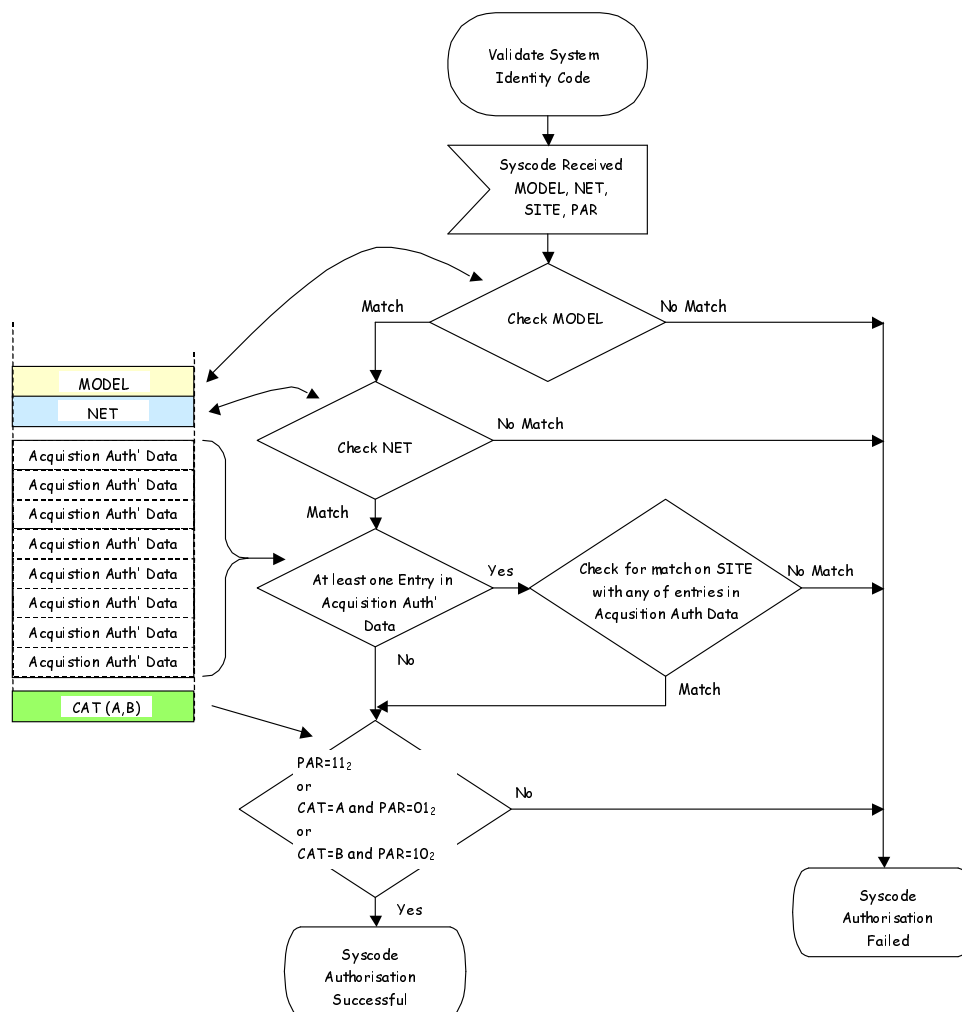

**Figure 6.17: Checking the C\_SYSCode**

Figure 6.17 illustrates the TSC Authorization procedure specified in clause 6.3.2.2.2 a), b), c) and d).

### 6.3.2.2.3 Checking the SYS\_AREA information element

If the MS has successfully verified the C\_SYSCode (according to clause 6.3.2.2.2), then it shall examine the SYS\_AREA information element from the C\_SYSCode. The SYS\_AREA is formed by applying a mask to the Site information element of width specified by DMRLA.

The SYS\_AREA information element is then compared with a list in the light of denied registrations applicable to the selected network held by the MS. (That list is discarded when the MS is switched off. see clauses 6.3.2.2.2 and 6.4.2).

If the value of the SYS\_AREA information element under examination matches with any of the records of denied registrations applicable to the selected network, then the MS unit shall not be authorized to acquire the TSCC under test.

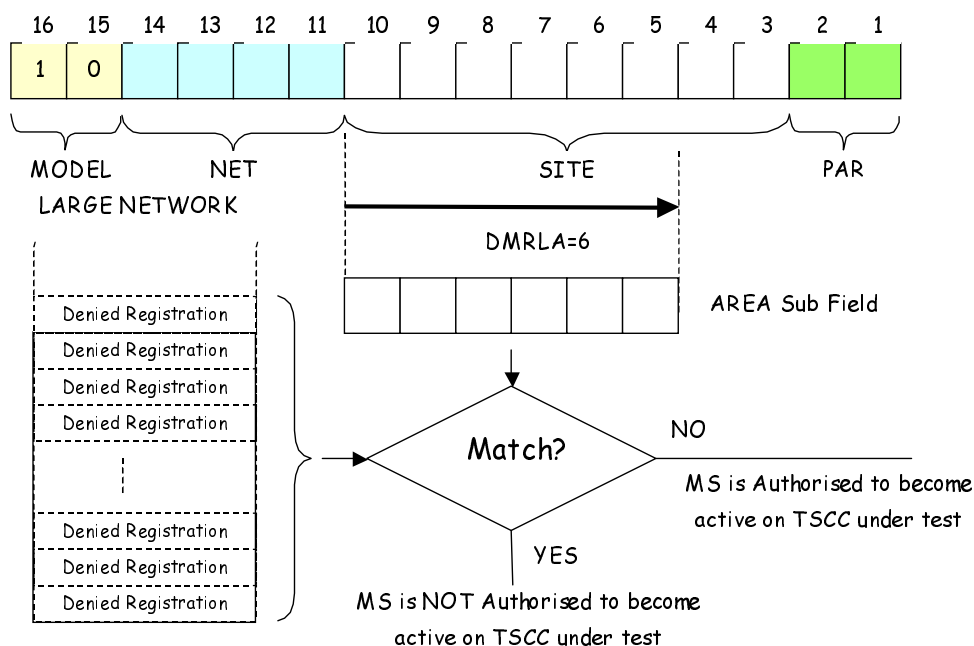

**Figure 6.18: SYS\_AREA information element from the C\_SYSCode**

**EXAMPLE:** A large network has MS personalized with DMRLA=6. The MS retrieves the SYS\_AREA information element from the C\_SYSCode and compares that result with each entry in the list of denied registrations. If there is a match in any one of the entries then the MS shall not be authorized to acquire the TSCC under test.

#### 6.3.2.2.3.1 Lifetime of SYS\_AREA entries in the denied registration list

The entire denied registration list is discarded when the MS is switched off (see clause 6.4.2).

If the timer T\_DENREG is non-zero, individual entries in the denied registration list shall have a limited lifetime. In this case the MS maintains a timer for each of the entries. If the timer for a particular SYS\_AREA expires, that SYS\_AREA shall be removed from the list.

#### 6.3.2.3 Confirmation - Monitoring the TSCC outbound channel signal quality

While idle on a control channel the MS shall determine the outbound channel signal quality. This may be e.g. examination of the error rate, from measurement of the RF signal strength.

The MS shall hold two thresholds of signal quality:

- One threshold shall be used while the MS is hunting for a TSCC prior to confirmation (see clause 6.3.2).
- The second threshold shall be used after verification and confirmation and the MS is idle on the TSCC.

**NOTE:** When an MS enters a call set-up phase, it suspends signal quality measurement of the TSCC.

### 6.3.3 MS Leaving a Control Channel

#### 6.3.3.1 Reasons for Leaving a Control Channel when active but idle

When active, the MS shall monitor the TSCC and return to hunting procedures if any of these conditions are met:

- After confirmation, the bit error rate exceeds the minimum prescribed in clause 6.3.2.3.
- The value of C\_SYSCode received differs from the value verified during acquisition authorization for a NSYSerr consecutive occurrences.

- c) No decodable TSCC PDUs are received by the MS for T\_Nosig seconds.
- d) The user initiates a change of selected network.
- e) A C\_MOVE PDU applicable to the MS is received . In this case the MS shall note the value of the CONT information element from the C\_MOVE PDU.
- f) The MS receives C\_NACKD(Reason=Reg\_Denied) as a result of sending a random access registration PDU. In the case of a random access registration request, the MS shall assume the hunt stage that it was last engaged in prior to the registration attempt.
- g) After C\_SYSCode confirmation, the MS receives C\_NACKD(Reason=Reg\_Refused) as a result of random access registration procedures. In this case the MS shall assume the hunt stage that it was last engaged in prior to the registration attempt.
- h) After confirmation, the MS has timed out after a random access registration procedure due to NRand\_NR being reached or Trand\_TC being exceeded. In this case the MS shall assume the hunt stage that it was last engaged in prior to the registration attempt.
- i) After confirmation, the MS has timed-out after a random access attempt for a service request, except registration, due to NRand\_NR or Nrand\_NE being reached or TRand\_TC being exceeded.

### 6.3.3.2 Leaving a Control Channel Whilst Waiting for Signalling

A MS waiting for signalling shall leave the TSCC on which it is currently active when any of the following events as listed in clause 6.3.3.1 occur - b), c), e). In such circumstances the MS shall retain its state of waiting for signalling during any hunting procedures and subsequent TSCC confirmation tests. Any timers relevant to the waiting state shall be maintained.

## 6.4 Registration, Power Save, and Authentication Procedures

The procedures defined in this clause support the generic and supplementary services. PDUs exchanged between the TS and MS contain device addresses that either identify a specific device (such as an MS), or a gateway (see clause A.4) that indicates the service being supported. For clarity the service, the PDUs and addresses are illustrated in table 6.7.

**Table 6.7: Services - PDUs - addresses cross reference**

Service	PDU	Source	Source Address	Destination Address (Target)	Notes
Registration	Random Access Request	MS	MS ID	REG_ADDR	0000 0000 <sub>2</sub> + C_SYSCode
	Acknowledgment	TS	REGI	MS ID	To the Random Access Request or final acknowledgement if the registration was subject to authentication
MS Authentication or part of registration	C_AHOY	TS	Authentication Challenge	MS ID	
	Acknowledgment	MS	MS ID	Authentication Result	To the Authentication Challenge
Stun/Revive	C_AHOY	TS	STUNI	MS ID	
	Acknowledgment	MS	MS ID	STUNI	To the C_AHOY or final acknowledgement if the stun/revive was subject to authentication
Stun/Revive (MS authenticates TS)	C_AHOY	TS	STUNI	MS ID	
	C_ACVIT	MS	MD_ID	Authentication Challenge	
	Acknowledgment	TS	Authentication Result	MD_ID	
	Acknowledgment	MS	MS ID	STUNI	

Service	PDU	Source	Source Address	Destination Address (Target)	Notes
MS Kill with authentication	C_AHOY	TS	KILLI	MS ID	Kill shall always be authenticated
	C_ACVIT	MS	MS_ID	Authentication Challenge	
	Acknowledgment	TS	Authentication Result	MS_ID	
	Acknowledgment	MS	MS ID	KILLI	
Registration with IP connection Advice	Random Access Request	MS	MS ID	REG_ADDR	0000 0000 <sub>2</sub> + C_SYSCode
	Acknowledgment	TS	REGI	MS ID	C_WACK or C_NACK only
	C_AHOY	TS	IPI	MS ID	
	C_UDTHU+AD	MS	MS ID	IPI	
Unsolicited MS Radio Check	C_AHOY P_AHOY	TS	TSI	MS ID or Talkgroup	IG indicates individual or talkgroup
	Acknowledgment	MS	MS ID	TSI	
Supplementary_user data Services supporting primary service	C_AHOY	TS	SUPLI	Calling Party MS ID	Inbound phase
	C_UDTHU+AD	MS	MS ID	SUPLI	
	C_UDTHD+AD	TS	SUPLI	Called Party MSID	Outbound Phase if applicable
	Acknowledgment	MS	MS ID	SUPLI	

## 6.4.1 Registration

### 6.4.1.1 Introduction

Registration is a method of recording the area or group of areas where a MS is likely to be located within a wide area network. This information avoids searching for MSs throughout the whole network, consequently reducing call set-up time and TSCC loading.

A secondary feature is that it provides a means of restricting the service to individual MSs to specific TSs by allowing the network to deny other registration requests (see clause 6.4.4.1.4).

The registration strategy describes two types of registration. The first of these is explicit registration, where registration is achieved by means of a MS random access procedure. The second is implicit registration, where registration is achieved as the result of any PDUs exchanged between a TSCC and a MS.

Explicit registration also enables MS to request power save. Power save is prescribed in clause 6.4.7.

A simple MS radio check procedure enables the TSCC to simply poll an individual MS for its presence at any time. This procedure is described in clause 6.4.12.

### 6.4.1.2 The Principle

The principle of registration requires that the MS shall only retain a valid registration record where it has received confirmation that it is the same record as that currently held within the network. If a MS fails to receive a response to a registration request, this could be due to:

- the registration request not being received by the network, in which case the network will regard the previous successful registration by the unit as the currently-valid registration record;
- the registration request being accepted by the network but the service answer response not being received by the MS, in which case the network will regard the unsuccessful registration by the unit as the currently-valid registration record.

Accordingly, in such cases the MS is not able to confirm whether the network holds a valid record for the unit and if it does, whether it is the previous registration or the present registration. The MS shall therefore only replace its current registration record when a successful registration is confirmed by a suitable service answer response to the registration service random access request from the TSCC.

The registration record shall be extracted from the C\_SYScore using the following procedure:

- c) The MS extracts the SITE parameter from the C\_SYScore.
- d) The MS then extracts the SYS\_AREA information from the SITE parameter by masking the most significant bits (MSBs) with DMRLA.

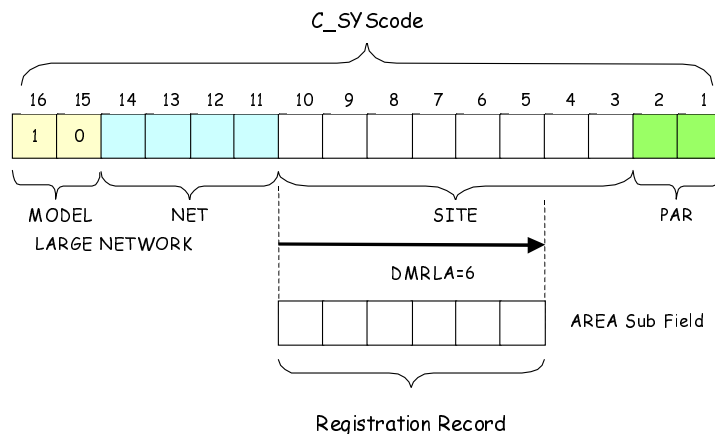

**Figure 6.19: Extraction of the registration record from the C\_SYScore**

**EXAMPLE:** Figure 6.19 shows a Large Network. The SITE parameter for a Large Network has a field length of 8 bits. DMRLA in this example=6, therefore the most significant 6 bits become the registration record.

## 6.4.2 MS Parameter Volatility

In order to satisfy the procedures specified in this clause and annex D, the MS shall retain certain parameters for each selected network when the MS is switched off. Other parameter shall be discarded when the MS is switched off. Table 6.8 lists the behaviour of each applicable parameter.

**Table 6.8: MS Parameter Volatility for Registration**

Parameter	Clause	Fixed during MS Personalization. Retained when MS is switched off	Changes during operation and retained when MS is switched off	Changes during operation and discarded when MS is switched off
The Current Registration Record	6.4.4		X	
List of Denied Registrations	6.3.2.2.3 (see note 1)			X
NOTE 1: At least 8 different values of SYS_AREA information element from the received C_SYScore verified when acquiring the TSCC on which a registration attempt by the MS has been denied. These shall be managed as a FIFO list: when the MS has a full list of entries, any further addition to the list shall displace the earliest entry.				
NOTE 2: Individual entries in the Denied Registrations list may be deleted by expiry of the denied registrations timer T_DENREG (see clauses 6.3.2.2.3.1 and 6.4.4.1.4).				

## 6.4.3 Action on confirmation of a TSCC

A MS shall not make any attempt at random access until TSCC confirmation has been achieved.

When a MS confirms a TSCC it shall either:

- a) if the Reg information element (carried in C\_ALOHA PDUs and in the CACH) is zero, the MS shall not seek to register by random access nor shall it create or alter any registration record. The MS shall note that registration is not required and that it is free to initiate calls; or

- b) if the verified SYS\_AREA information element from the C\_SYSCODE matches any entry in the list of denied registrations then the MS shall not be authorized to acquire the TSCC under test. The MS shall resume hunting; or
- c) if the MS does not hold a successful registration record for the verified SYS\_AREA, the MS shall attempt to register by random access.

The Reg information element carried in the C\_ALOHA PDUs and in the CACH shall be the same value.

NOTE: The Reg information element in the C\_ALOHA PDU is always applicable and not affected by the Mask(C\_ALOHA) parameter.

Once confirmed on a TSCC, the MS shall not transmit any PDU other than:

- a) registration service random access request PDU; or
- b) an acknowledgement to an authentication challenge as specified in clause 6.4.8.3;

until it holds a successful registration record relating to the verified SYS\_AREA unless Reg = 0.

If the MS holds a successful registration record relating to the verified SYS\_AREA code, it is free to transmit any PDU conforming to the requirements of the present document.

## 6.4.4 Registration Procedures

The procedures for explicit MS registration are prescribed in clauses 6.4.4.1 to 6.4.4.9. Figures 6.21 to 6.23 illustrate the registration process MSCs including the optional authentication step.

### 6.4.4.1 Registration by Random Access

When a MS determines that it is required to register, it shall attempt to do so by random access using the procedures defined in clause 6.2. If the random access timeout C\_RandTC expires and the MS has not sent a random access registration request, the MS shall enter the TSCC acquisition procedures.

The information elements in the random access request are passed to the CC layer - set appropriately as prescribed in table 6.9.

Table 6.9: C\_RAND information elements for the MS Registration Service

Information Element (I.E), I.E	Length	length	Alias	Value	Remark
Service_Options	7	1		0 <sub>2</sub>	Reserved
		1		0 <sub>2</sub>	Privacy (see note 1)
		1	IP_INFORM	0 <sub>2</sub>	MS is not advising IP connection
				1 <sub>2</sub>	MS is advising IP connection
		3	PS_RQ	0 <sub>2</sub>	Power Save not requested
				001 <sub>2</sub> to 111 <sub>2</sub>	Power Save requested
		1	REG_DEREG	0 <sub>2</sub>	If IP_Inform=0 <sub>2</sub> the MS is attempting to de-register. If IP_Inform=1 <sub>2</sub> the MS is deleting an IP connection
1 <sub>2</sub>	If IP_Inform=0 <sub>2</sub> the MS is attempting to register. If IP_Inform=1 <sub>2</sub> the MS is attempting to register and/or adding an IP connection				
Proxy Flag	1		PROXY	0 <sub>2</sub>	
Reserved	2			00 <sub>2</sub>	
Reserved	2			00 <sub>2</sub>	
Service_Kind	4		REG_SRV	1110 <sub>2</sub>	Registration Service
Target_address or Gateway	24		REG_ADDR	Value	Registration Address (see note 2)
Source_address	24			Value	Individual Address of the requesting MS
NOTE 1: Privacy is not defined in the present document.					
NOTE 2: REG_ADDR is an information element that is formed from 0000 0000 <sub>2</sub> + C_SYSCode.					

Immediately upon sending the registration request by random access, the MS shall delete its current SYS\_AREA code retained from its previous registration.

Valid TSCC responses to the random access request are C\_WACKD(Reason=Wait) more signalling to follow, C\_ACKD(Reason=Reg\_Accepted), C\_NACKD(Reason=Reg\_Refused), C\_NACKD(Reason=Reg\_Denied), or C\_AHOY(Source Address=Authentication\_Challenge) (see clause 6.4.8). ACK type PDUs shall set the target address to MS individual address and the Source Address to REGI.

The TSCC shall only send a response to the random access request if the C\_SYSCode in the REG\_ADDR information element of the C\_RAND matches the C\_SYSCode being transmitted by the TSCC. If the REG\_ADDR information element in the C\_RAND received by the TSCC does not match the C\_SYSCode being transmitted by the TSCC, the TSCC shall discard the C\_RAND registration message.

NOTE: REGI is the registration identifier (see clause A.4).

Clauses 6.4.4.1.1 to 6.4.4.1.5 describe the possible responses to a MS registration request. The final acknowledgement PDU defines if the MS is permitted access to that TSCC.

If the final acknowledgement to the MS from TSCC is Registration Refused, the MS shall resume hunting. If the MS does not locate an alternative TSCC that permits access, the MS returns to this TSCC and repeats the procedure. On a highly loaded system, this may result in high registration traffic. If however the TSCC sends a Registration Denied as the final acknowledgement, the MS adds the SYS\_AREA to a list of denied registrations. The procedure defined in clause 6.4.3, b) then bars the MS from making any further random access registration requests to this TSCC. Registration denied is therefore the preferred TSCC final response to reject a MS from acquiring a particular TSCC.

NOTE : The denied registration list is cleared when the MS is switched off.

#### 6.4.4.1.1 Intermediate Acknowledgement

If the TSCC cannot respond immediately to the random access request, it can send a C\_WACKD(Reason=Wait) to the MS. This acknowledgement shall start timer TNP\_Timer in accordance with clause 6.2.1.2. If further signalling is not received after the expiry of the timer, the MS shall comply with the procedures in clause 6.4.4.1.6.

#### 6.4.4.1.2 Registration accepted

The registration attempt shall be considered successful on receipt of ACK(Reason=Reg\_Accepted). The MS shall record the SYS\_AREA information from the TSCC C\_SYSCode. The MS shall replace any old registration record with the new record extracted from the C\_SYSCode.

#### 6.4.4.1.3 Registration Refused

The registration attempt shall be considered to have been unsuccessful if the MS receives C\_NACKD(Reason=Reg\_Refused).

The MS shall resume hunting, and after confirming a TSCC and receiving a suitable C\_ALOHA PDU, shall re-commence a random access registration attempt.

Until a successful registration is achieved, the MS shall not attempt to transmit other than random access registration service requests.

#### 6.4.4.1.4 Registration Denied

The registration attempt shall be considered denied if the MS receives C\_NACKD(Reason=Reg\_Denied). The MS shall add the SYS\_AREA code to the list of denied registration records and enter the TSCC acquisition procedures.

If T\_DENREG is non-zero the MS shall start a timer equal to the value of T\_DENREG for that entry in the denied registration list.

#### 6.4.4.1.5 Challenge and Response Authentication

The TSCC may apply an intermediate step of authenticating the MS during the registration procedure.

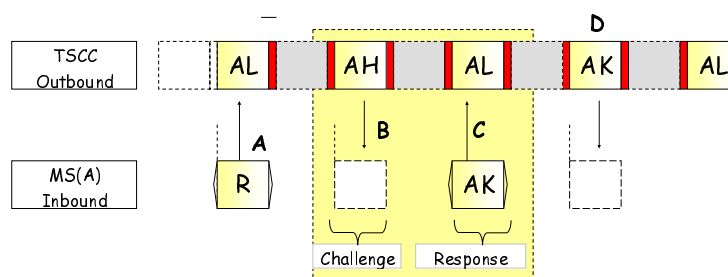

**Figure 6.20: Registration with authentication check**

Figure 6.20 shows a MS registration procedure with the optional steps "B" and "C":

- At "A" the MS makes a random access registration attempt.
- The AHOY PDU at "B" is the acknowledgement to the random access and challenges the MS to respond with its authentication response. The timer TNP\_Timer timer is started.
- "C" is the MS response to the TSCC containing the authentication response.
- The final C\_ACKD or C\_NACKD is sent by the TSCC to the MS.

The specific authentication procedures are prescribed in clause 6.4.8.



#### 6.4.4.1.6 Registration Attempt Times Out

If the MS times out from waiting for further signalling for the registration (expiry of timer TNP\_Timer), it shall enter the TSCC acquisition procedures.

#### 6.4.4.1.7 Registration Demand Received During Random Access Registration

The TS shall avoid conflict in the protocol. If, while waiting for a response to a random access registration request PDU, the MS receives a C\_BCAST(Announcement\_type=MassReg) PDU applicable to the MS, the MS shall note the information elements from the C\_BCAST and initiate the procedure specified in clause 6.4.5.1 then continue with its registration request in accordance with the random access procedures.

#### 6.4.4.1.8 No answer response Received after the maximum number of random access attempts

If no response is received within WAIT+1 slots after the MS has transmitted NRand\_NR random access attempts, the MS shall make no consequential changes to its registration record.

#### 6.4.4.1.9 Registration Action on Switch-on or equivalent

If an MS determines that the TSCC requires MS to register, the MS shall register by random access on switch on or change of selected network.

6.4.4.1.10 Registration scenario MSC

Illustration of the explicit registration procedure as defined in clauses 6.4.4.1 to 6.4.4.9.

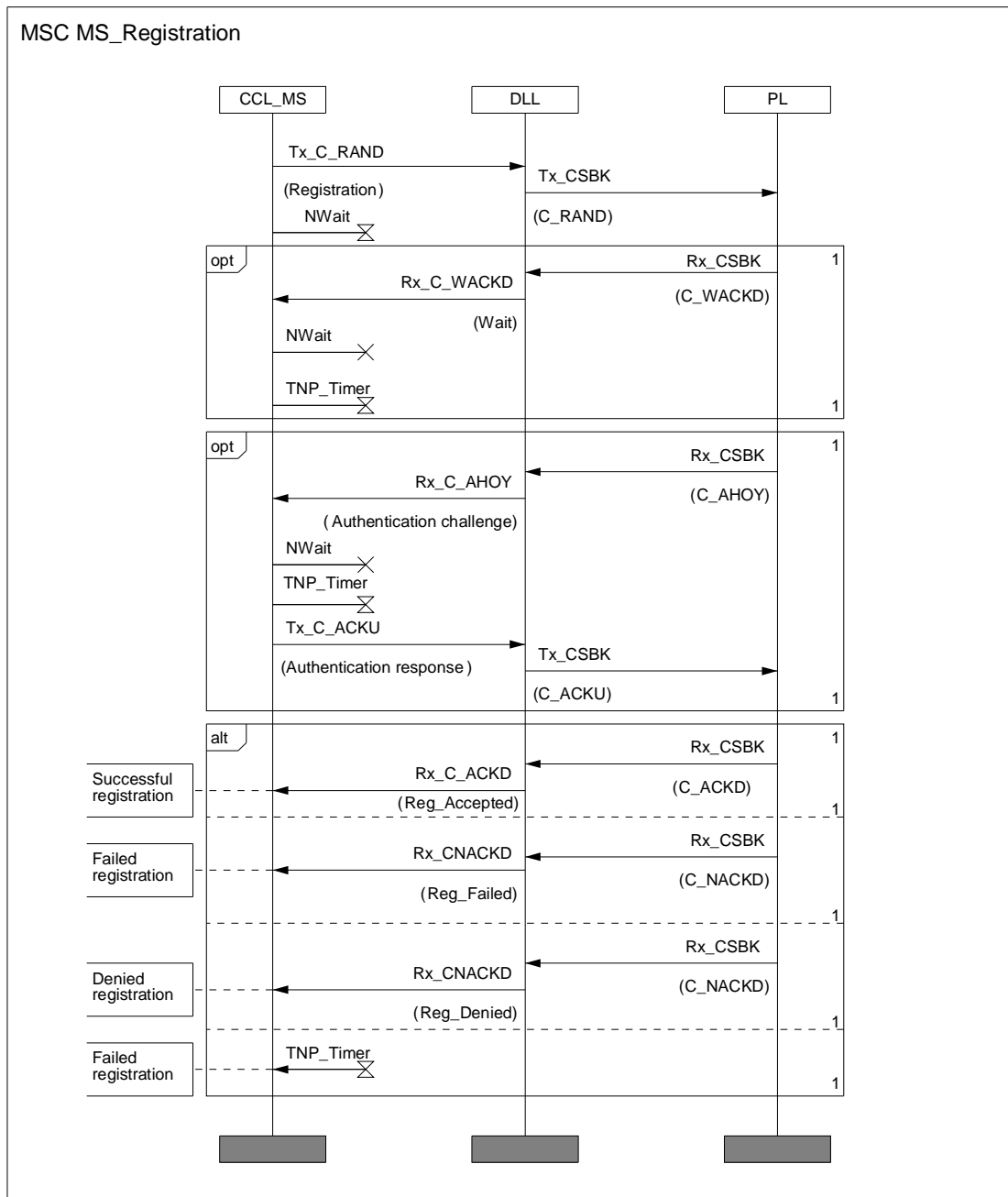

Figure 6.21: MS Registration MSC

## 6.4.4.1.11 Registration with MS authentication

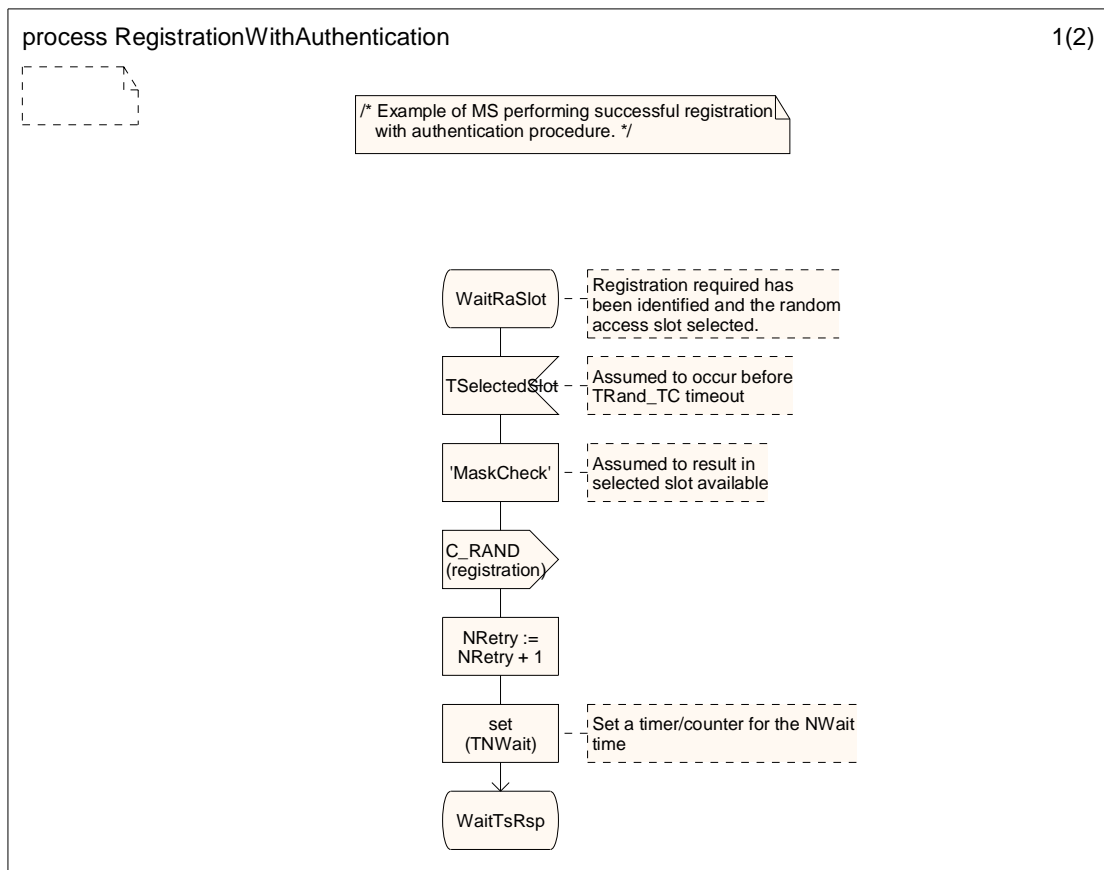
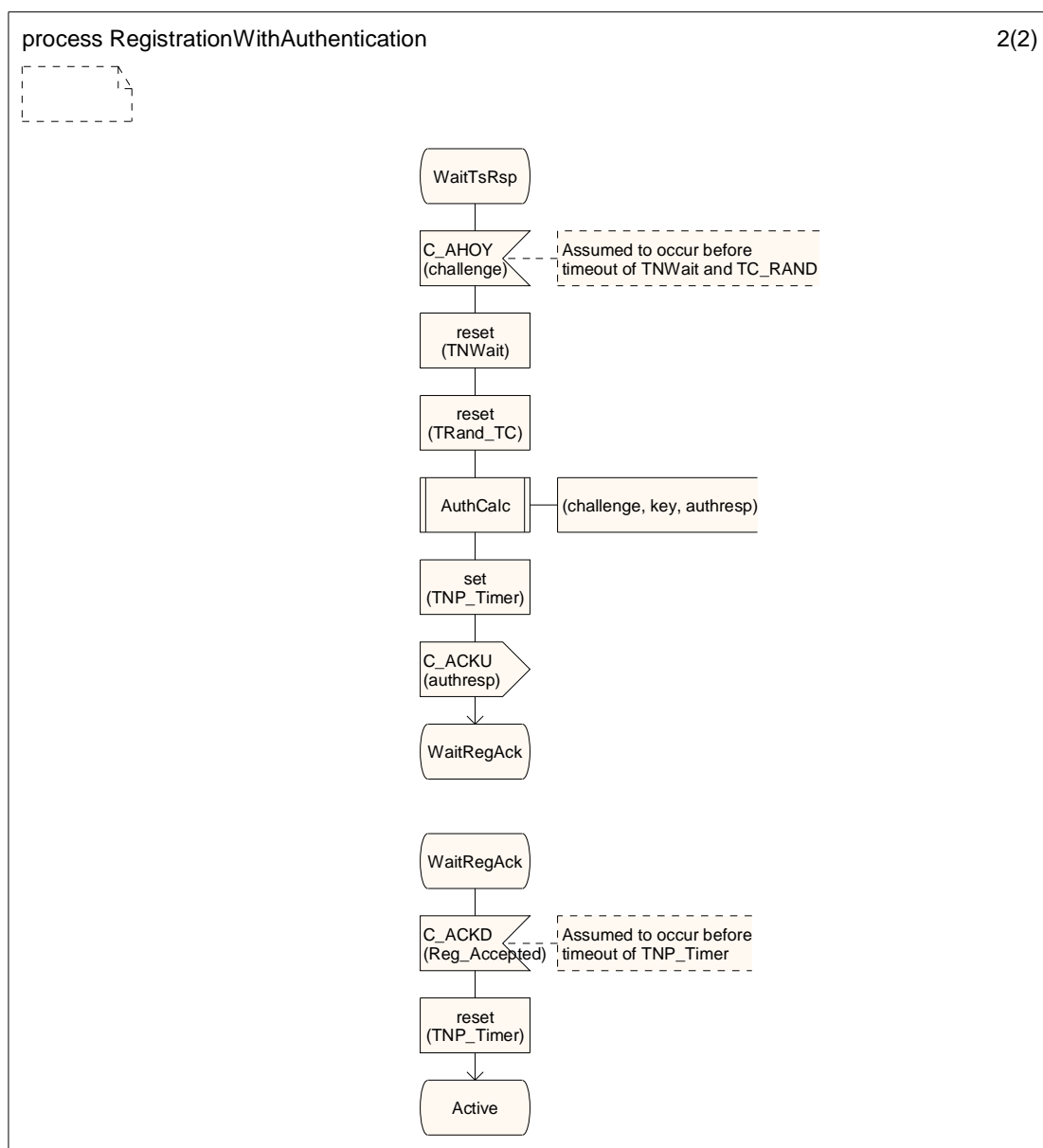

Figure 6.22 (sheet 1 of 2): Registration with Authentication SDL



**Figure 6.23 (sheet 2 of 2): Registration with Authentication SDL**

#### 6.4.4.1.12 Acceptance of user initiated service requests

For voice and data services, users request a particular service by transmitting a random access service request. The TSCC may require MS to be registered with that TSCC before accepting such a service request. If the TSCC is configured such that service requests are only accepted to registered MS and a MS that is not registered makes a service request then the TSCC shall respond with a C\_NACKD(Reason= MS\_Not\_Registered).

## 6.4.5 Mass re-registration

A wide area network relies on the integrity of the registration records for MS location management. It is possible that the records may be suspect for many reasons including loss of connections between the various TS. This clause describes a mechanism whereby a TSCC may re-establish those registration records from the MS that are currently confirmed on that TSCC. A broadcast PDU is transmitted on the TSCC that causes all applicable MS that are confirmed to re-register by random access. If this re-registration procedure is activated it is essential to avoid congestion from the increased random access activity that would result. To manage this process therefore, a Reg\_Window information element is transmitted in the broadcast PDU that permits MS to make their random access registration attempt over an extended period of time.

An MS shall note the delay parameter Reg\_Window from the C\_BCAST(Announcement\_type=MassReg) PDU it receives and shall use table 6.10 to derive from it a time window to make a random access registration attempt.

The Mass registration may be used to demand a registration from a specific MS by setting the MS address in the Mass Registration Broadcast PDU to the individual address of a MS and setting the Mask = 24.

### 6.4.5.1 Procedure for MS on receipt of Mass Re-registration Broadcast

When confirmed on a TSCC a MS shall make use of information C\_BCAST(Announcement\_type=MassReg). This PDU may be transmitted on the TSCC to cause all MS or a subset of the MS population to re-register by random access.

A MS shall note the population subdivision contained in each C\_BCAST(Announcement\_type=MassReg) PDU that it receives (as prescribed in clause 6.1.3) using the qualifier (Mask) and the address field from the C\_BCAST PDU. For Mask = 0 to 24, the PDU is applicable to the MS if the "Mask" least significant bits of the C\_BCAST address information element match the "Mask" least significant bits of its individual address.

**Table 6.10: Reg\_Window lookup for Mass-Registration**

Reg_Window	Treg_Window	Reg_Window	Treg_Window
0	Cancel Mass Reg	8	100
1	0,5	9	300
2	1	10	1 000
3	2	11	3 000
4	5	12	10 000
5	10	13	30 000
6	20	14	100 000
7	30	15	200 000

If the MS determines that the C\_BCAST(Announcement\_type=MassReg) PDU is applicable, the MS shall:

- examine the Reg\_Window information element from the C\_BCAST(Announcement\_type=MassReg). If the Reg\_Window information element is non-zero, the MS shall derive the window size TReg\_Window (in seconds) for a Random Access Registration attempt using table 6.10;
- choose a random number (using a statistically uniform distribution) from zero to TReg\_Window;
- count real time seconds until the random value is reached;
- make a random access registration attempt using the procedures prescribed in clause 6.4. If the MS is in power save mode, the PowerSave\_RQ information element in the Service\_Options of the registration service request shall be set to maintain the power save mode currently in operation;
- also count real time seconds until the TReg\_Window slot is reached. If the MS receives other applicable C\_BCAST(Announcement\_type=MassReg) containing a non zero Reg\_Window information element before Reg\_Window is reached the MS shall ignore that C\_BCAST PDU;
- if Power Save is in operation, the TSCC shall ensure that the Mass-Registration is transmitted in the wake period.

If the MS is confirmed on a TSCC and the MS receives other applicable C\_BCAST(Announcement\_type=MassReg) containing a zero Reg\_Window information element the mass re-registration procedure and any pending random access attempt shall be cancelled. If such a broadcast is received when the random access procedure is in progress that random access procedure shall be completed before the mass re-registration procedure is cancelled.

If the MS leaves the currently confirmed TSCC, and successfully confirms a different TSCC, any Mass-registration procedure shall be cancelled.

## 6.4.6 De-registration

When an MS is switched off, or a user initiated change of system is invoked, the MS may first attempt to de-register from the current system. It shall attempt to do so by random access using the procedures defined in clause 6.2. In the Service\_Options of the registration service request the information elements shall be set to IP\_Inform=0<sub>2</sub>, Reg\_Dereg=0<sub>2</sub> and PowerSave\_RQ=000<sub>2</sub>.

When an MS switch-off or change of network is performed, the MS shall start a timer T\_Dereg.

Immediately upon sending the de-registration request by random access, the MS shall discard its current SYS\_AREA code retained from its previous registration.

The only valid TSCC response to the de-register random access request shall be C\_ACKD(Reason=Reg\_Accepted). If the acknowledgement is received, the MS shall complete the switch off or change of network.

If timer T\_Dereg expires, the MS shall abandon the de-registration procedure and complete the action of switch-off or change of network.

## 6.4.7 Power Save

### 6.4.7.1 Overview

Tier III systems may support a synchronized power saving feature.

An MS can synchronize to the timing parameters that have been exchanged with the TSCC and adopt a periodic sleep cycle. Calls to that MS shall be synchronized to the wake-up periods (power save frames) that are agreed between MS and the TSCC.

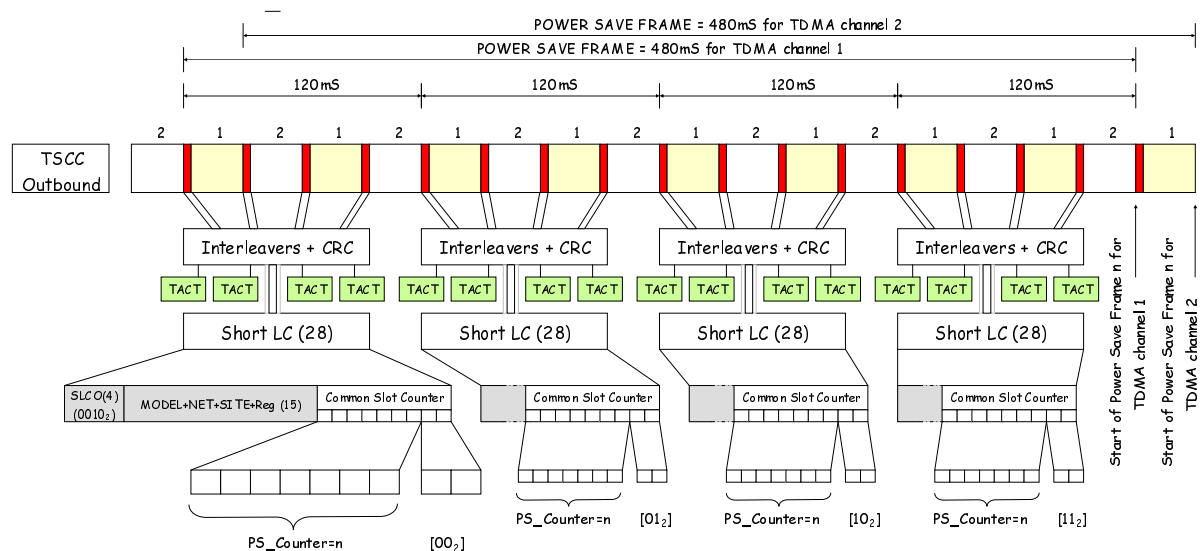

Figure 6.24: Power Save Frame Structure

The power save frames are defined by the PS\_Counter information element, a sub-set of the Common\_Slot\_Counter broadcast in the CACH. A sleeping MS shall wake for a designated power save frame. If the TSCC has a PDU or transaction for the sleeping MS, that PDU shall be queued until a designated power save frame is transmitted on the TSCC. MS or other entity that initiates a transaction to a sleeping MS (or group of MSs) shall be queued on the TSCC until the designated power save frame has been reached. Figure 6.24 shows a power save frame. For each logical channel there are eight slots available to signal MS during a designated power save frame.

- a) The MS and TSCC shall have previously synchronized a particular wake frame.
- b) The TSCC shall know when a particular MS has woken and is able to receive signalling addressed to that MS. If several MSs are in a fleet and are party to a talkgroup call, all MSs in that particular talkgroup may share the same wakeup frame. The way in which the TSCC manages the power save and allocates particular wakeup frames is not prescribed in the present document.
- c) Different MSs sharing a common TSCC may have differing power save and the TSCC/MSs shall be able to deal with this.
- d) The Short LC that carries the Power Save Counter does not have to be continuously transmitted. When MS have received a Power Save Short LC they are able to calculate power save frames from that point. MS may then refresh by occasional appropriate short LC PDUs.

## 6.4.7.2 Power Save Procedures

### 6.4.7.2.1 Basic Power Save Procedures

For a MS to activate power save, it registers with the TSCC. In the registration service request the MS may ask for power save it wishes to employ, by sending a non-zero three bit PowerSave\_RQ information element with a number between 1 and 7. A registration service request with a zero PowerSave\_RQ indicates that no power save is required or a previous power save is cancelled. The TSCC responds positively if it supports power save for that request, with a PowerSave\_Offset information element (length 7) in the range 1, 1 to 3, 1 to 7, 1 to 15, 1 to 31, 1 to 63 or 1 to 127.

**Table 6.11: Power Save information elements during MS registration**

Power Save	PowerSave_RQ	PowerSave_Offset
OFF	0	0
1:2	1	1
1:4	2	1 to 3
1:8	3	1 to 7
1:16	4	1 to 15
1:32	5	1 to 31
1:64	6	1 to 63
1:128	7	1 to 127

If the MS has requested Power Save and the TSCC does not wish to permit that MS access, the TSCC shall respond C\_NACKD(Reason=Reg\_Denied)

If the MS has requested Power Save and the TSCC responds with PowerSave\_Offset=0, the MS shall interpret this as meaning registration accepted but Power Save either not supported or not available.

A PowerSave\_RQ=1 indicates the MS shall sleep for one Power Save Frame and awake for the second. A "2" indicate 1 awake and 3 sleeping. A "3" indicates 1 in 8 awake and so on. In this example the greatest power save would be "7" indicating 1 in 128 awake as illustrated in table 6.11.

The TSCC responds with an acknowledgement containing a PowerSave\_Offset information element (the Response\_Info information element in the acknowledgement PDU) that indicates the power save frame number that the TSCC will send signalling to that particular MS. The TSCC may therefore average out signalling across all power save frames for differing fleets (or differing talkgroups). The frame number is read by the MS and a mask applied according to the power save request. The answer gives the power save frame number for that power save value asked for in the registration request. The MS can then calculate when to wake for incoming traffic.

**EXAMPLE:** A MS requests a power save of 4 by setting the value of PowerSave\_RQ = 2 in the registration service request. The TSCC responds with Powersave\_Offset = 2.

The PS\_Counter is counting up continuously. Suppose the PS\_Counter at this moment = 65<sub>decimal</sub>.

**Table 6.12: Power Save Example - MS state**

PS_Counter	Count	Mask Counter with PowerSave RQ							MS state
		0	1	0	0	0	0	1	
...	.....	..							..
65	010 0001 <sub>2</sub>	0	1	0	0	0	0	1	- Sleep
66	010 0010 <sub>2</sub>	0	1	0	0	0	1	0	- Wake
67	010 0011 <sub>2</sub>	0	1	0	0	0	1	1	- Sleep
68	010 0100 <sub>2</sub>	0	1	0	0	1	0	0	- Sleep
69	010 0101 <sub>2</sub>	0	1	0	0	1	0	1	- Sleep
70	010 0110 <sub>2</sub>	0	1	0	0	1	1	0	- Wake
...	.....	..	..	..	..	..	..	..	.....

Table 6.12 shows how a TSCC determines when a MS is awake. The TSCC applies a mask of length PowerSave\_RQ. In this example the mask leaves two bits. When the masked PS\_Counter equals the PowerSave\_Offset the TSCC may signal the MS.

MS can sample the CACH at any time, read the Common\_Slot Counter and determine when the wake frame will be transmitted. The MS may then sleep until a point at which its wake frame is scheduled. A PDU addressed to the MS by its individual address shall cause the MS to awaken for T\_Awake seconds. Each MS individually addressed or applicable talkgroup address PDU transmitted on the TSCC or MS shall refresh T\_Awake. If no PDUs have been transmitted or received by the MS when T\_Awake expires the MS shall return to its sleeping state retaining its previous power save settings.

If an MS awakes and receives an applicable C\_AHOY PDU for a OACSU call that will result in a payload channel being assigned, the MS shall stay awake for a time T\_Pending for the Channel Grant PDUs to be transmitted. When that call is completed and the MS returns to the TSCC, the MS shall wait for T\_Awake seconds and then return to the sleeping state.

If an MS awakes and receives an applicable C\_AHOY PDU for a FOACSU call that will result in a payload channel being assigned, the MS shall stay awake for a time T\_AnswerCall for the Channel Grant PDUs to be transmitted. When that call is completed and the MS returns to the TSCC, the MS shall wait for T\_Awake seconds and then return to the sleeping state.

If while awake, the MS receives a C\_MOVE PDU, the MS shall retain its T\_Awake timer and return to its sleeping state after T\_Awake expires, unless the move to the replacement TSCC causes the MS to re-register when new power save information elements shall be exchanged.

## 6.4.8 Authentication Procedures

Authentication is a procedure to verify that a MS (or TSCC) is genuine. The procedures rely on a key that is shared between an individual MS and the TS. When authenticating an MS, a convenient point for applying the authentication procedure is during MS registration. When a MS attempts to register by random access, the TSCC sends a random number in a C\_AHOY PDU (the challenge). The MS calculates the response to the challenge using the RC4 keystream generator, keyed with the concatenation of the random number followed by the key, to generate 259 bytes of pseudo-random keystream. The first 256 bytes are discarded, with the last 3 bytes being transmitted as response.



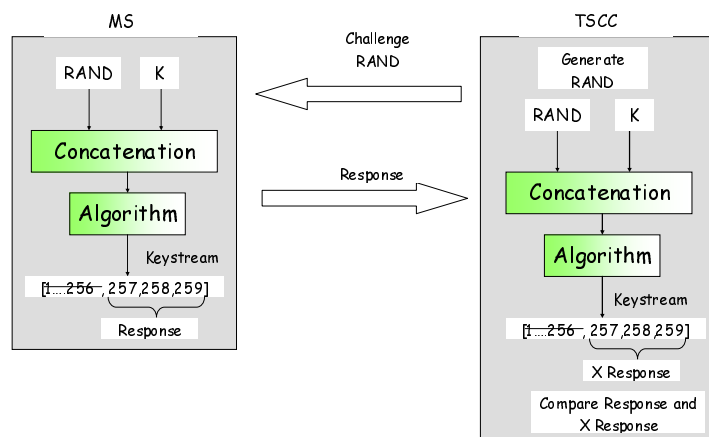

**Figure 6.25: Challenge and Response Authentication**

Figure 6.25 shows the mechanism. The MS calculates the response to the challenge. The TSCC uses the same algorithm and the same K,RAND values as the MS. The TSCC then compares the expected response with the actual response. If the responses match then the authentication is considered successful.

Table 6.13 illustrates a test vectors result when applying the algorithm.

**Table 6.13: Test Vectors**

Random Challenge	Key	Response
7A <sub>16</sub> 17 <sub>16</sub> C0 <sub>16</sub>	01 <sub>16</sub> 02 <sub>16</sub> 03 <sub>16</sub> 04 <sub>16</sub> 05 <sub>16</sub> 06 <sub>16</sub> 07 <sub>16</sub> 08 <sub>16</sub> 09 <sub>16</sub> 0A <sub>16</sub> 0B <sub>16</sub> 0C <sub>16</sub> 0D <sub>16</sub> 0E <sub>16</sub> 0F <sub>16</sub> 10 <sub>16</sub>	E8 <sub>16</sub> CA <sub>16</sub> 1D <sub>16</sub>

### 6.4.8.1 Key Management

A 128 bit authentication key (K) is programmed into each MS. Key generation is specific to each manufacturer and not specified in the present document. The (K) of each MS is also programmed into the TS. (K) is intended to be valid for the lifetime of the MS, but if (K) is compromised for a particular MS, a manufacturer may choose to re-program the key (K) both in the MS and in the network management.

NOTE: A compromised key only affects one MS and not the entire system.

### 6.4.8.2 Authentication Procedures for the TSCC to authenticate a MS

The TSCC challenges an MS by transmitting a C\_AHOY PDU to an individual MS address and information elements as illustrated in table 6.14.

If the C\_AHOY is transmitted as part of the registration procedure, the Service\_Options\_Mirror is set to the Service\_Options from the C\_Rand PDU.

If the C\_AHOY is transmitted in response to call set-up request, the Service\_Options\_Mirror is set to the Service\_Options from the C\_Rand PDU.

If the C\_AHOY is transmitted as an authentication poll from the TSCC (and unconnected with a registration procedure) the Service\_options\_Mirror shall be set to 000 0000<sub>2</sub>.

**Table 6.14: C\_AHOY information elements for authentication challenge**

Service_Options_Mirror	7	
Service_Kind_Flag	1	0 <sub>2</sub>
Ambient Listening Service	1	0 <sub>2</sub> - Not Applicable
IG	1	0 <sub>2</sub> - Target address is an individual MS address
Appended_Blocks	2	00 <sub>2</sub>
Service_Kind	4	1110 <sub>2</sub> – Authentication Service
Target address	24	Address of Challenged MS
Source Address or Gateway	24	Authentication challenge value. The challenge value shall be in the range 000000 <sub>16</sub> to FFFCDF <sub>16</sub>

### 6.4.8.3 Authentication Procedures for the MS

If an MS receives an applicable C\_AHOY PDU it shall pass the authentication challenge value to the authentication algorithm. The result from this algorithm is a 24 bit authentication result. That is transmitted to the TSCC by a C\_ACKU PDU. The relevant information elements are illustrated in table 6.15.

**Table 6.15: Authentication response elements**

Response_Info	7	value
Reason Code	7	0100 1000 <sub>2</sub> – Authentication Response
Reserved	1	0 <sub>2</sub>
Target address	24	authentication challenge response
Additional Information (Source Address)	24	MS individual address that is transmitting the acknowledgement

## 6.4.9 MS Stun/Revive

MS may be denied access to certain Tier III services using the stun mechanism. If a MS has been disabled by a stun procedure, the MS may not request nor receive any user initiated services on the network that performed the procedure. However hunting and registration, authentication, stun / revive and registration services shall remain active.

While an MS is stunned, it may also retain the NMEA (IEC 61162-1 [8]) polling service described in clause 6.6.5.1.5.

In the present document, MS shall only be stunned/revived from a TSCC gateway STUNI as described in clause 6.4.9.1.1.

### 6.4.9.1 MS Stun/Revive without authentication

**Figure 6.26: MS Stun/Revive Procedure**

Figure 6.26 shows the mechanism where the MS does not demand authentication prior to the stun.

- The TSCC sends a C\_AHOY from STUNI at "A".
- MS makes an appropriate acknowledgement at "B".

#### 6.4.9.1.1 Stun / Revive procedures for the TSCC

The TSCC transmits a C\_AHOY with the information elements as illustrated in table 6.16.

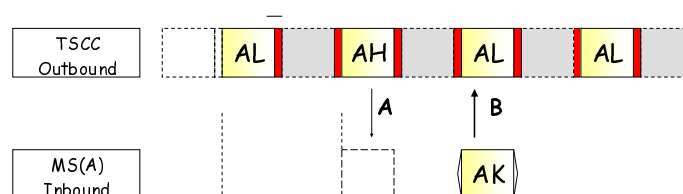
**Table 6.16: C\_AHOY information elements for Stun/Revive**

Service_Options_Mirror	7	000 0000 <sub>2</sub>
Service_Kind_Flag	1	0 <sub>2</sub> to stun, 1 <sub>2</sub> to revive
Ambient Listening Service	1	0 <sub>2</sub> - Not Applicable
IG	1	0 <sub>2</sub> - PDU addressed to an individual MS address
Appended_Blocks	2	00 <sub>2</sub>
Service_Kind	4	Supplementary Service - 1101 <sub>2</sub>
Target address	24	Individual Address of the MS to stun
Source Address or Gateway	24	STUNI (see clause A.4)

- If the response is C\_ACKU(Reason=Message\_Accepted) the TSCC shall interpret the acknowledgement that the stun/revive procedure was successful.
- If the response is C\_NACKU (Reason=MSNot\_Supported) the TSCC shall interpret the acknowledgement that stun/revive is not supported by the MS.

#### 6.4.9.1.2 Stun / Revive procedures for the MS

If the MS receives an applicable stun/revive C\_AHOY but the MS does not support stun / revive it shall respond with C\_NACKU (Reason=MSNot\_Supported).

If the MS receives an applicable stun/revive C\_AHOY and the MS supports stun / revive it shall examine the Service\_Kind\_Flag, call the appropriate stun or revive procedure and respond with C\_ACKU (Reason=Message\_Accepted).

#### 6.4.9.2 MS Stun/Revive with authentication

**Figure 6.27: MS Stun/Revive with Authentication**

Figure 6.27 shows the mechanism where the MS demands authenticates the TSCC prior to the stun:

- The TSCC sends a C\_AHOY from STUNI at "A" to stun the MS.
- The MS makes its authentication challenge at "B" by transmitting a C\_ACVIT PDU. This Ackvitation sent by the MS is the acknowledgement to the initial C\_AHOY from the TSCC.
- At "C" the TSCC sends the challenge response to the MS. The MS authenticates the challenge response. If the challenge response is ratified by the MS, the MS stuns/revives and sends C\_ACKU(Reason=Authentication\_Response). If the challenge response fails authentication, the MS shall send C\_NACKU(Reason=Recipient\_Refused) ("D"), and the MS shall not stun. The TSCC may repeat step "C" if a response is not successfully received at "D".
- At "D" the final acknowledgement is sent to the TSCC. If the challenge response is ratified by the MS, the MS stuns/revives and shall send C\_ACKU(Reason=Message\_Accepted). If the challenge response fails authentication, the MS shall send C\_NACKU(Reason=Recipient\_Refused), and the MS shall not stun. The TSCC may repeat step "C" if a response is not successfully received at "D".

#### 6.4.9.2.1 Stun / Revive procedures with authentication for the TSCC

The TSCC transmits a C\_AHOY with the information elements as illustrated in table 6.16.

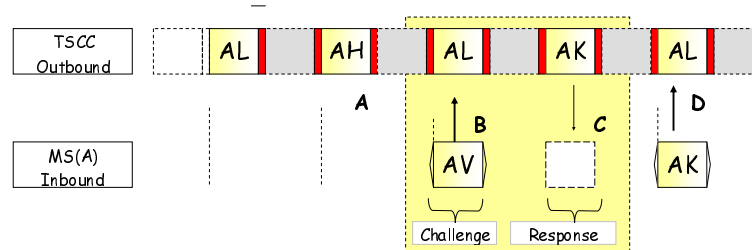
If the MS response is a C\_Ackvitation (Target Address=challenge value, Source Address=MS\_ID the TSCC shall interpret that PDU as an acknowledgement and that the TSCC is being challenged that the TSCC is authentic.

The TSCC shall send the response C\_ACKD(Reason=Authentication\_Response) with the information elements as illustrated in table 6.17.

**Table 6.17: Authentication Response Elements**

Response_Info	7	value
Reason Code	8	0110 1000 <sub>2</sub> Authentication Response
Reserved	1	0 <sub>2</sub>
Target address	24	The address of the stunned MS
Additional Information (Source Address)	24	Authentication Challenge Response

When the TSCC response to the challenged has been transmitted to the MS, the MS shall send a final acknowledgement:

- a) If the final acknowledgement transmitted by the MS is C\_ACKU(Message\_Accepted) the TSCC shall identify that the stun/revive procedure was successful.
- b) If the final acknowledgement transmitted by the MS is C\_NACKU(Recipient\_Refused) the TSCC shall identify that the authentication was unsuccessful.

#### 6.4.9.2.2 Stun / Revive procedures with authentication for the MS

If the MS receives an applicable stun/revive C\_AHOY but the MS does not support stun / revive it shall respond with C\_NACKU (Reason=MSNot\_Supported).

If the MS receives an applicable stun/revive C\_AHOY the MS shall authenticate the TSCC by transmitting a C\_Ackvitation with information elements as illustrated in table 6.18.

**Table 6.18: C\_Ackvitation - MS challenges the TSCC**

Service_Options_Mirror	7	0000 000 <sub>2</sub>
Service_Kind_Flag	1	0 <sub>2</sub> to stun, 1 <sub>2</sub> to revive
Reserved	2	0 <sub>2</sub>
Appended_Blocks	2	00 <sub>2</sub>
Service_Kind	4	Supplementary Service - 1101 <sub>2</sub>
Target address	24	Authentication Challenge Value. The challenge value shall be in the range 000000 <sub>16</sub> to FFFCDF <sub>16</sub>
Source Address or Gateway	24	MS Individual Address

The MS shall examine the response to the authentication challenge and validate the authentication. The MS shall then send a final acknowledgement C\_ACKU(Reason=Message\_Accepted) if the authentication was successful or C\_NACKU(Reason= Recipient\_Refused) if the authentication was unsuccessful.

If the MS supports stun / revive it shall then examine the Service\_Kind\_Flag, and call the appropriate stun or revive procedure.

**Table 6.19: Final Acknowledgement**

Response_Info	7	value
Reason Code	8	Message_Accepted - 0100 0100 <sub>2</sub>
		Recipient_Refused - 0001 0100 <sub>2</sub>
Reserved	1	0 <sub>2</sub>
Target address	24	STUNI (see clause A.4)
Additional Information (Source Address)	24	MS Individual Address

## 6.4.10 MS Kill

MS may be completely and permanently disabled using the kill mechanism. If a MS has been killed by a kill procedure, the MS shall lose all DMR functionality. An MS may not be revived from the kill state by any AI generated message.

In the present document, MS shall only be killed from a TSCC gateway KILLI.

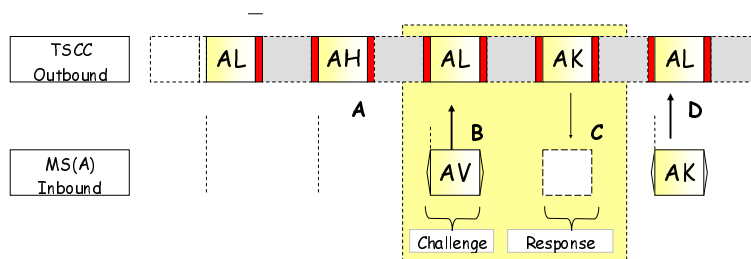

**Figure 6.28: MS Kill (with Authentication)**

Figure 6.28 illustrates the mechanism for MS kill:

- The TSCC sends a C\_AHOY from KILLI at "A" to kill the MS.
- The MS acknowledges the C\_AHOY in the next slot and makes its authentication challenge at "B" by transmitting a C\_ACVIT PDU. This Ackvitation sent by the MS is the acknowledgement to the initial C\_AHOY from the TSCC.
- At "C" the TSCC sends the challenge response to the MS. The MS authenticates the challenge response. This response may be delayed in accordance with the random access timing defined in clause 6.2.1.1.4. The MS authenticates the challenge response.
- At "D", if the challenge response is ratified by the MS, the MS sends C\_ACKU(Reason=Message\_Accepted). Following the acknowledgement the MS disables all DMR functionality. If the challenge response fails authentication, the MS shall send C\_NACKU(Reason=Recipient\_Refused) ("D"), and the MS shall not kill.

The MS may repeat step "B" if the challenge response is not successfully received by the TSCC at "C".

NOTE: A situation may exist where the final acknowledgement C\_ACKU was sent by the MS (and the MS disabled all functionality) but the acknowledgement was not received by the TSCC. In this case, repeating the kill procedure from step "A" would not result in any response from the MS. The TSCC should be able to deal with this situation.

### 6.4.10.1 Kill procedures with authentication for the TSCC

The TSCC transmits a C\_AHOY with the information elements as illustrated in table 6.20.

**Table 6.20: C\_AHOY information elements for Kill**

Service_Options_Mirror	7	000 0000 <sub>2</sub>
Service_Kind_Flag	1	0 <sub>2</sub>
Ambient Listening Service	1	0 <sub>2</sub> - Not Applicable
IG	1	0 <sub>2</sub> - PDU addressed to an individual MS address
Appended_Blocks	2	00 <sub>2</sub>
Service_Kind	4	Supplementary Service - 1101 <sub>2</sub>
Target address	24	Individual Address of Called MS
Source Address or Gateway	24	KILLI (see clause A.4)

If the MS response is a C\_Ackvitation (Target Address=challenge value, Source Address=MS\_ID) the TSCC shall interpret that PDU as an acknowledgement and that the TSCC is being challenged that the TSCC is authentic.

The TSCC shall send the response C\_ACKD(Reason=Authentication\_Response) with the information elements as illustrated in table 6.21.

**Table 6.21: Authentication Response Elements**

Response_Info	7	value
Reason Code	8	0110 0000 <sub>2</sub> - Authentication Response
Reserved	1	0 <sub>2</sub>
Target address	24	Individual Address of the killed MS
Additional Information (Source Address)	24	authentication challenge response

When the TSCC response to the challenge has been transmitted to the MS, the MS shall send a final acknowledgement:

- a) if the final acknowledgement transmitted by the MS is C\_ACKU(Message\_Accepted) the TSCC shall identify that the kill procedure was successful;
- b) if the final acknowledgement transmitted by the MS is C\_NACKU(Recipient\_Refused) the TSCC shall identify that the kill was unsuccessful.

#### 6.4.10.2 Kill procedures with authentication for the MS

If the MS receives an applicable kill C\_AHOY but the MS does not support kill it shall respond with C\_NACKU (Reason=MSNot\_Supported).

If the MS receives an applicable kill C\_AHOY the MS shall authenticate the TSCC by transmitting a C\_Ackvitation with information elements as illustrated in table 6.22.

**Table 6.22: C\_Ackvitation – MS Challenges the TSCC**

Service_Options_Mirror	7	0000 000 <sub>2</sub>
Service_Kind_Flag	1	0 <sub>2</sub>
Reserved	2	0 <sub>2</sub>
Appended_Blocks	2	00 <sub>2</sub>
Service_Kind	4	Supplementary Service - 1101 <sub>2</sub>
Target address	24	Authentication Challenge Value. The challenge value shall be in the range 000000 <sub>16</sub> to FFFCDF <sub>16</sub>
Source Address or Gateway	24	MS Individual Address

The MS shall examine the response to the authentication challenge and validate the authentication. The MS shall then send a final acknowledgement C\_ACKU(Reason=Message\_Accepted) if the authentication was successful or C\_NACKU(Reason=Recipient\_Refused) if the authentication was unsuccessful (illustrated in table 6.23).

**Table 6.23: Final Acknowledgement**

Response_Info	7	Value
Reason Code	8	Message_Accepted - 0100 0100 <sub>2</sub>
		Recipient_Refused - 0001 0100 <sub>2</sub>
Reserved	1	0 <sub>2</sub>
Target address	24	KILLI (see clause A.4)
Additional Information (Source Address)	24	MS Individual Address

## 6.4.11 IP Connection Advice

For a MS to forward an IP connection address to the Tier III network, the MS makes use of the registration procedures specified in clause 6.4.4 to register (or repeat the registration) with the TSCC (see note). In the registration service request the Service Options contain the IP\_Inform information element. If the MS registers with the IP\_Inform=1<sub>2</sub>, the TSCC invokes the UDT procedures and sends a AHOY to ask the MS for an IP connection address.

- the MS may repeat this procedure if it has additional IP addresses to send to the system;
- the MS may delete an IP connection by sending a registration service deregister with Reg\_Dereg=0<sub>2</sub> and IP\_Inform=1<sub>2</sub> (This combination of information elements does not deregister the MS).

If the TSCC has the IP addresses for MS registered, the TSCC is able to cross reference the IP address with the MS individual address if the MS has activated power save.

The PDU exchange to add or subtract an IP connection and request power save is illustrated in figure 6.29.

NOTE: The MS may already be registered with the system. Repeating the registration procedure is however a convenient mechanism to convey IP connection addresses.

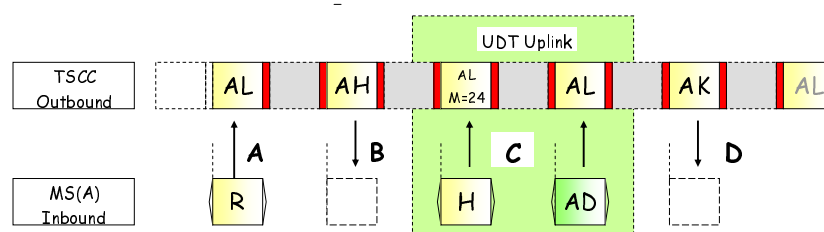

Figure 6.29: MS IP Connection Advice

Figure 6.29 shows a MS registration procedure with the optional steps "B" and "C":

- at "A" the MS makes a random access registration attempt with IP\_Inform=1<sub>2</sub>;
- the AHOY PDU at "B" is the acknowledgement to the random access and asks the MS to respond with the IP connection advice. The timer TNP\_Timer timer is started;
- "C" is the MS response using the UDT IP format;
- the final C\_ACKD or C\_NACKD is sent on the TSCC to the MS.

### 6.4.11.1 IP Connection Advice procedures for the MS

When a MS determines that it wished to advise a change of IP connection (i.e. add or delete an IP address), it shall attempt to do so by the registration procedures specified in clause 6.4.4. The indication that a registration request is for the purpose of IP connection advice is the information element IP\_Inform=1<sub>2</sub> in the Service Options (see table 6.9).

Valid TSCC responses to the random access request are - C\_WACKD(Reason=Wait) more signalling to follow, C\_NACKD(Reason=Reg\_Refused), C\_NACKD(Reason=Reg\_Denied), or C\_AHOY(Source Address or Gateway=IPI). If the TSCC response is an acknowledgement, the PDU destination address shall be MS ID and the Source address shall be REGI.

#### 6.4.11.1.1 Registration Attempt Times Out

If the MS times out from waiting for further signalling for IP connection request and the MS was not previously registered, (expiry of timer TNP\_Timer), it shall enter the TSCC acquisition procedures. If the MS was previously registered, the MS shall return to the TSCC idle state.

#### 6.4.11.1.2 No answer response received after the maximum number of random access attempts

If no response is received within WAIT+1 slots after the MS has transmitted N<sub>Rand\_NR</sub> random access attempts, the MS shall make no consequential changes to its IP connection record.

#### 6.4.11.1.3 MS response to C\_AHOY inviting the MS to send an IP address

The MS shall send the IP address using the UDT mechanism. The response shall be a HEAD+appended data. The HEAD information elements shall be UDT\_Format=0110<sub>2</sub>, UAB=00<sub>2</sub> for IPV4 or UAB=01<sub>2</sub> for IPV6, SF=1<sub>2</sub>, Target\_address=MS ID, Source\_address=IPI.

#### 6.4.11.1.4 Final acknowledgment to IP connection advice received by the calling MS

The MS may receive C\_ACKD=Reg\_Accepted. In that case the MS shall assume that the IP connection advice was accepted by the TSCC.

If the TSCC refuses the IP connection advice the MS may receive C\_NACKD(Reason=IP\_Connection\_failed). In that case the MS shall assume that the IP connection advice has not been accepted by the TSCC. No change in the IP connection record shall be made.

### 6.4.11.2 IP Connection Advice procedures for the TSCC

If the TSCC receives a random access registration request attempt with IP\_Inform=1<sub>2</sub>, and the TSCC wishes to accept an IP connection address, it shall transmit a C\_AHOY from IPI inviting the MS to send the IP address using the UDT mechanism.

The TSCC may transmit any of the acknowledgements C\_WACKD(Reason=Wait) more signalling to follow, C\_NACKD(Reason=Reg\_Refused), C\_NACKD(Reason=Reg\_Denied), or C\_AHOY(Source Address or Gateway=IPI). If the TSCC response is an acknowledgement the PDU destination address shall be MS ID and the Source address shall be REGI.

The TSCC may not be able to accept the IP address. In that case the TSCC shall send C\_NACKD(Reason=IP\_Connection\_failed). The TSCC shall not change the IP connection record.

### 6.4.12 Unsolicited MS Radio Check

When an MS is not involved in a call set up, if a TS wishes to check if an MS is listening, a simple unsolicited MS radio check may be conducted at any time.

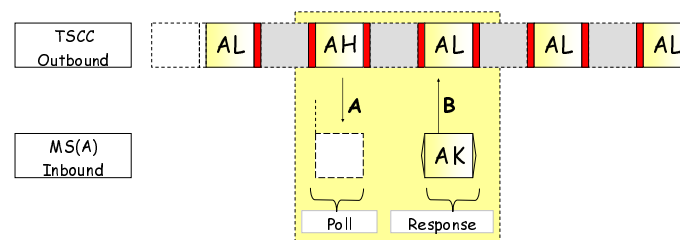

**Figure 6.30: MS Radio Check**

Figure 6.30 illustrates the message exchange for an unsolicited radio check on the control channel. An unsolicited MS Radio Check may also be conducted on the traffic channel. The TSCC (or TS) transmits a C\_AHOY with the information elements as illustrated in table 6.24.



**Table 6.24: C\_AHOY information elements for an unsolicited MS Radio Check**

Service_Options_Mirror	7	000 0000 <sub>2</sub>
Service_Kind_Flag	1	0 <sub>2</sub> Not Applicable
Ambient Listening Service	1	0 <sub>2</sub> - Not Applicable
IG	1	0 <sub>2</sub> Target address is a MS individual ID
		1 <sub>2</sub> Target address is a talkgroup
Appended_Blocks	2	00 <sub>2</sub>
Service_Kind	4	Registration/Authentication/MS Radio Check - 1110 <sub>2</sub>
Target address	24	Polled MS
Source Address or Gateway	24	TSI (see clause A.4)

The MS shall send the response C\_ACKU(Reason=Message\_Accepted) with the information elements as illustrated in table 6.25.

**Table 6.25: MS Radio Check Response Elements**

Response_Info	7	value
Reason Code	8	0100 0100 <sub>2</sub>
Reserved	1	0 <sub>2</sub>
Target address	24	TSI
Additional Information (Source Address)	24	MS individual address

Whether the MS was polled by its individual address or a talkgroup, the C\_ACKU Source Address shall always be the MS individual address.

### 6.4.13 Supplementary\_User Data Service

The inbound supplementary\_user data service may be invoked as part of another service. It enables supplementary\_user data to be transferred between entities as part of a voice or data call setup. The inbound phase illustrated in figure 6.31 is invoked by a C\_AHOY (Source address=SUPLI) addressed to the MS. The MS response is a UDTHU(Source address=MS ID, Target\_address=SUPLI) + one to four appended data blocks.

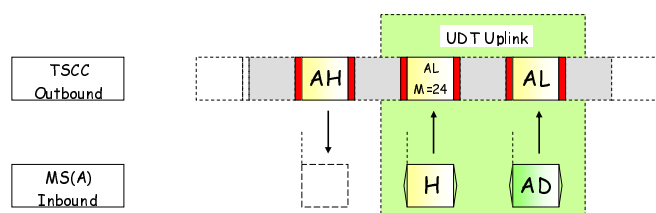
**Figure 6.31: Supplementary\_User Data Service inbound**

For the inbound supplementary service, the supplementary data exchange shall follow any AHOY/Acknowledgement PDUs that are part of the call set-up.

The outbound phase illustrated in figure 6.32 is composed of a UDTHD(Source address=SUPLI, Target\_address=MS ID) + one to four appended data blocks. If the MS accepts the supplementary\_user data the acknowledgement shall be a C\_ACKU(message\_accepted) (Source\_address=MS ID, Target\_address=SUPLI).

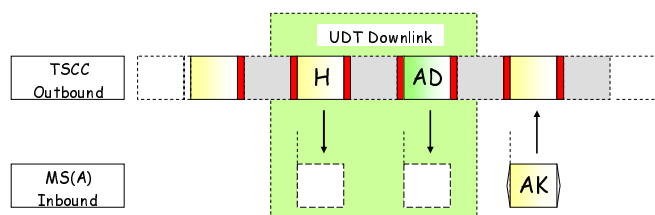

**Figure 6.32: Supplementary\_User Data Service outbound**

For the outbound supplementary service, and calls that do not allocate a traffic channel (e.g. UDT short data) the UDT carrying the payload shall be the last UDT outbound. (that is the supplementary outbound phase shall precede the UDT carrying the payload data).

A complete example of a voice call invoking supplementary\_user data is illustrated in figure 6.37.

## 6.4.14 MS Power Control and Transmitter Pre-emption Control

Closed loop power control is a method by which a TS is able to dynamically control the transmitter output power of an MS. If a Tier III TS or MS supports this feature, the feature shall be implemented as described in this clause.

A trunked network may employ a combination of MS that do and do not support this feature. In addition, it shall be noted that this feature uses the Reverse Channel (RC) and the RC may not always be available. The Tier III system shall be able to deal with this.

The principle of power control is:

- The TS measures the received signal strength of a transmitting MS, and compares the received value with two programmable thresholds. The thresholds are the upper limit for the received signal strength (L\_Power\_Hi) and the lower limit (L\_Power\_Low). If the received signal strength exceeds the threshold L\_Power\_Hi, the TS will send a decrease power PDU to the MS. If the signal strength is below the lower limit L\_Power\_Low, the TS will send an increase power control PDU to the MS.

The principle of transmitter pre-emption control is:

- Transmitter pre-emption control may be implemented to stop an MS transmission so that a new call of higher priority may use the channel.

### 6.4.14.1 Reverse Channel

Both MS power control and MS transmitter pre-emption control use the Reverse Channel. The 11 bits of the Reverse Channel are subdivided into the RC SAP (5 bits) and the Commands (6 bits as illustrated in table 6.25).

**Table 6.26: MS Reverse Channel information elements for Power Control and Transmitter Control**

RC SAP			Reverse Channel			
Length	Value	Description	Length	Value	Description	
5	0 0000 <sub>2</sub>	Reserved	6			
	0 0001 <sub>2</sub>	Power Control			00 0000 <sub>2</sub>	Reserved
				00 0001 <sub>2</sub>	Increase power by one step	
				00 0010 <sub>2</sub>	Decrease power by one step	
				00 0011 <sub>2</sub>	Set power to highest	
				00 0100 <sub>2</sub>	Set power to lowest	
	0 0010 <sub>2</sub>	Pre-emption Control			00 0101 <sub>2</sub> to 11 1111 <sub>2</sub>	Reserved
					00 0000 <sub>2</sub>	Reserved
					00 0001 <sub>2</sub>	Cease transmission immediately
					00 0010 <sub>2</sub>	Stop transmission at the end of the next voice frame
0 0011 <sub>2</sub> to 1 1111 <sub>2</sub>	Reserved		00 0101 <sub>2</sub> to 11 1111 <sub>2</sub>	Reserved		

NOTE: The power step size is manufacturer dependent.

#### 6.4.14.2 Procedures for Power Control

The RC repetition rate for power control shall be 360 ms. If MS receive a RC PDU with the RC SAP set to 0 0001<sub>2</sub>, the MS shall examine the RC Command to adjust the transmit power setting. If the MS is transmitting at maximum power and receives an "increase power" RC Command, the MS shall retain its maximum power setting. Similarly, if the MS is transmitting at minimum power and receives a "decrease power" RC Command, the MS shall retain its minimum power setting.

#### 6.4.14.3 Procedures for Transmission Pre-emption Control

MS may support transmission pre-emption control. The TS shall transmit one or more SAP RC PDUs with the RC SAP set to 0 0010<sub>2</sub> to cause the MS to cease transmission. The TS shall then monitor the channel to ascertain if the MS did cease transmission. Two options are permitted:

- cease transmission immediately;
- stop transmission at the end of the next voice frame.

If the MS did not cease transmission, it may be that the MS did not successfully receive the RC PDU or the MS does not support the feature. The TS may repeat the RC PDU.

## 6.5 Unified Data Transport Mechanism

A Tier III network supports a wide range of services. To support these services, the transporting of data is a very common necessity. Although Short Data is a primary data service, there are many instances where data needs to be transported to support other services. (For example when a MS dials a PABX or PSTN destination, the dialled digits are uploaded to the TSCC). Whether the data remains within the network or is used to support other services, the Supplementary Data Transfer Service may be invoked. To reduce the Tier III complexity, all data transport using the TSCC share a common method - the Unified Data Transport Mechanism.

- a) Supplementary Data Transfer Service:
  - 1) inbound transport of destination addresses that are connected through system gateways;

- 2) inbound transport of PSTN and PABX dialling digits from MS;
  - 3) inbound transport of IPV4/IPV6 addresses;
  - 4) inbound transport of MS NMEA (IEC 61162-1 [8]) location information;
  - 6) outbound channel transport of remote addresses that are connected through system gateways;
  - 7) outbound channel transport of CLI information from PABX/PSTN networks;
  - 8) outbound channel transport of IPV4/IPV6 address information from IP networks;
  - 9) outbound channel transport of a Source Address in a number of standard and proprietary formats;
  - 10) outbound channel transport of NMEA (IEC 61162-1 [8]) MS location;
  - 11) transport of supplementary\_user data as part of another service.
- b) Short Data Transfer Delivery Service.
  - c) Short Data Polling Service.
  - d) Inbound transport of digits for the Call Diversion Service.

The format for the data transfer is the same for transfers using the outbound channel and transfers using the inbound channel. The UDT employs the UDT type (UDT) PDU. The first block is the header as illustrated in figure 6.33. This block carries source and destination addresses, the format of the data being carried, and UDT Format that denotes the service being supported. Up to four Appended data blocks may follow the header to carry the data. All blocks of the UDT shall be transmitted consecutively.

UDT HEADER									
	7	6	5	4	3	2	1	0	
Octet 0	IG	A	RSVD		FORMAT				
Octet 1	SAP				UDT FORMAT				
Octet 2	TARGET ADDRESS OR GATEWAY(24)								
Octet 3									
Octet 4									
Octet 5	SOURCE ADDRESS OR GATEWAY(24)								
Octet 6									
Octet 7									
Octet 8	PAD NIBBLE				0	UAB			
Octet 9	SF	PF	OPCODE						

**Figure 6.33: UDT Header**

The UAB information element indicates the number of UDT blocks that are appended to this header. For a UDT addressed to an individual MS, the A information element denotes if a response to this multi-block UDT is expected.

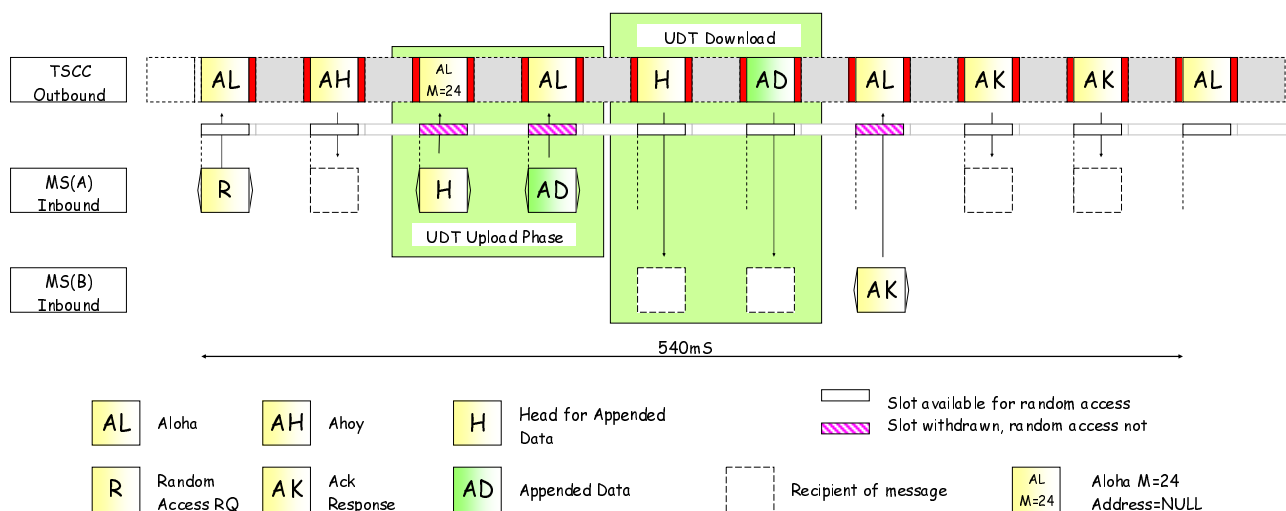

**Figure 6.34: A Short Data call using the UDT mechanism**

Figure 6.34 is just one example showing how the Short Data service makes use of the UDT mechanism. The Short Data employs a store and forward technique and the procedures are fully described in clause 6.6.4.

However the UDT segments are highlighted to show the upload and download phases that are described in these clauses. In this example the MBC blocks consist of a Header + one appended block.

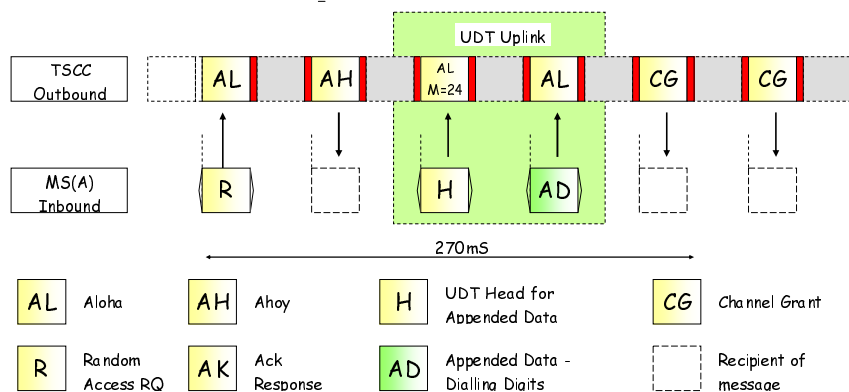

**Figure 6.35: MS to PABX/PSTN Call using the UDT Mechanism**

Figure 6.35 illustrates a call set-up for a call from an MS to the PABX/PSTN. Calls to these destinations are characterized by the necessity of passing the dialled destination to the system. The UDT mechanism provides an unambiguous transfer. In this example the UDT consists of a Header + one appended block for up to 20 dialled digits.

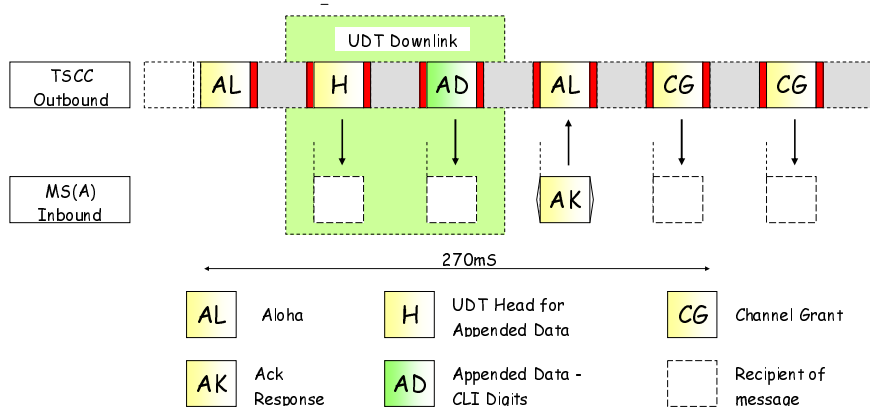

**Figure 6.36: Call from the PSTN/PABX using the UDT Mechanism**

Figure 6.36 illustrates a further example of a call from the PSTN. The TSCC has elected to download the CLI information to the recipient as part of this call set-up. The Service\_Kind information element is passed in the header therefore the recipient MS knows the call is inbound and the call is from the PSTN. Since the Service\_Kind is known to the recipient, a secondary feature of the UDT mechanism is that it may serve as a radio check. Only if the MS responds with a positive (C\_ACKU) acknowledgement does the call mature.

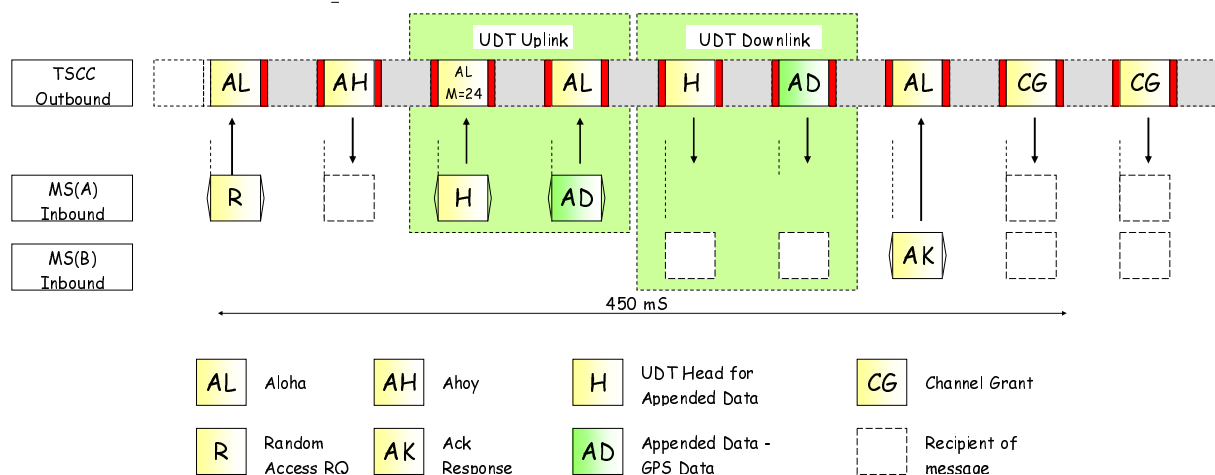

**Figure 6.37: UDT mechanism carrying supplementary data**

Figure 6.37 shows how supplementary\_user data may be carried as part of a call. MS(A) wishes to send its GPS position as part of a voice call set-up. MS therefore elects to indicate that supplementary\_user data is available in the Service\_Options information element by setting Supplementary\_Data=1<sub>2</sub>. The TSCC uploads the supplementary\_user data and passes the data to the recipient. The UDT download/acknowledgement also serves as the radio check.

## 6.5.1 Format of the appended data

The format of the appended data is specified in annex B. The standard formats are:

- Address format - the appended block(s) contain DMR addresses.
- Binary Format - the appended block(s) contain binary data.
- BCD format - the appended blocks contain digit coded.
- 7 bit text coded - the appended data is text coded using ISO 7 bit character set (ISO/IEC 646 [11]).
- 8 bit character coded - the appended data is character coded using ISO 8 bit character set (ISO/IEC 8859 [12]).
- NMEA (IEC 61162-1 [8]) location format - the appended data is coded specifically for NMEA (IEC 61162-1 [8]) position data.
- 16 bit UTF-16BE Unicode format [9].

### 6.5.1.1 UDT Block Structure

The UDT block structure is described in TS 102 361-1 [5] in the following clauses:

- header: clause 8.2.1.8;
- non-last block: clause 8.2.2.1;
- last data block: clause 8.2.2.5.

## 6.5.1.2 UDT Content for Services Carried on the Outbound channel

The UDT outbound channel mechanism may be invoked as part of a DMR service. The UDT head PDU contains all parameters for a MS or talkgroup UDT. The data to be downloaded is held in the TSCC and the information elements formed as table 6.27.

Table 6.27: UDT Outbound channel information elements

UDT Outbound channel Mechanism								
UDT Outbound channel PDUs								
Service	Operation	Service_Kind	Supplementary_Data_Flag	UDT-Format	UDT_Response	Target address or gateway	Source or gateway Address	MS Response to Head+Data
Voice Call from PSTN to Individual MS	Send CLI information from PSTN	Individual Voice Call Service (0001 <sub>2</sub> )	1 <sub>2</sub>	BCD (0010 <sub>2</sub> )	0 <sub>2</sub> option	Destination MS Address	PSTNI	No
					1 <sub>2</sub> option			ACK, NACK
Voice Call from PABX to Individual MS	Send CLI information from PABX	Individual Voice Call Service (0001 <sub>2</sub> )	1 <sub>2</sub>	BCD (0010 <sub>2</sub> )	0 <sub>2</sub> option	Destination MS Address	PABXI	No
					1 <sub>2</sub> option			ACK, NACK
Voice Call from PSTN to Talkgroup	Send CLI information from PSTN	Talkgroup Voice Call Service (0010 <sub>2</sub> )	1 <sub>2</sub>	BCD (0010 <sub>2</sub> )	0 <sub>2</sub>	Destination Talkgroup	PSTNI	No
Voice Call from PABX to Talkgroup	Send CLI information from PABX	Talkgroup Voice Call Service (0010 <sub>2</sub> )	1 <sub>2</sub>	BCD (0010 <sub>2</sub> )	0 <sub>2</sub>	Destination Talkgroup	PABXI	No
Voice Call from MS to Individual MS	Send NMEA information from Source MS	Individual Voice Call Service (0001 <sub>2</sub> )	1 <sub>2</sub>	NMEA formatted (0101 <sub>2</sub> )	0 <sub>2</sub> option	Destination MS Address	Source MS	No
					1 <sub>2</sub> option			ACK, NACK
Voice Call from MS to Individual MS	Send supplementary text PDU as part of call setup	Individual Voice Call Service (0001 <sub>2</sub> )	1 <sub>2</sub>	7 bit txt (0011 <sub>2</sub> )	0 <sub>2</sub> option	Destination MS Address	Source MS	No
					1 <sub>2</sub> option			ACK, NACK
Short Data call from MS to MS	Short Data Outbound Phase	Indiv" Short Data (0100 <sub>2</sub> )	0 <sub>2</sub>	UDT_For mat	1 <sub>2</sub>	Destination MS Address	Source MS	ACK, NACK
Short Data call from Dispatcher to MS	Short Data Outbound Phase	Indiv" Short Data (0100 <sub>2</sub> )	0 <sub>2</sub>	UDT_For mat	1 <sub>2</sub>	Destination MS Address	DISPATI	ACK, NACK
Send Diverted address to caller	See clause 6.6.7							

The information elements of the PDUs in the UDT Header information elements are summarized:

UDT_Format	specifies the format of the data transported in the appended data blocks of the multi-block UDT
	if the UDT outbound is the second phase preceded by a UDT Inbound, the UDT_Format shall be copied from the UDT_Inbound Header
Appended_Blocks	specifies the number of appended data blocks concatenated to the header
Supplementary_Flag	specifies if: <ul style="list-style-type: none"> <li>- this UDT Header is carrying the data for a user initiated service (e.g. Short Data Delivery); or</li> <li>- this UDT Header is carrying supplementary_user data, supporting another service</li> </ul>
UDT_Response	specifies if the TSCC is expecting a response from this UDT download: <ul style="list-style-type: none"> <li>- if the UDT download is addressing an individual MS then: <ul style="list-style-type: none"> <li>* if the UDT download is supporting an Supplementary_User Data transfer then this information element may be set or clear</li> <li>* for the Short Data Service then this information element shall be set to 1<sub>2</sub> <ul style="list-style-type: none"> <li>- response expected</li> </ul> </li> </ul> </li> <li>- if the UDT download is addressing a talkgroup then: <ul style="list-style-type: none"> <li>* the UDT information element shall be set to 0<sub>2</sub> - response not expected</li> </ul> </li> </ul>
Service_Kind	specifies the service being supported by the UDT mechanism
Target_address or Gateway	individual MS address or Talkgroup or All_Unit
Source_address or gateway	source MS address for a service originating from an MS PABXI for a service originating from a PABX extension PSTNI for a service originating from the PSTN IPI for a service originating from an IP network

### 6.5.1.3 UDT Mechanism for the Inbound channel

The UDT inbound channel mechanism is invoked as part of a DMR service. The UDT head PDU contains all parameters for the UDT. The data to be uploaded is set as table 6.28. This table is not exhaustive and many other arrangements are possible to support Tier III services.

**Table 6.28: UDT Inbound channel information elements**

UDT Inbound channel Mechanism							
Service	Operation	Service_Kind	UDT Inbound channel information elements				
			Supplementary_Flag	Format	UDT_Response	Target address or gateway	Source Address or gateway
Voice Call from Individual MS to PSTN	Send PSTN dialling information from MS	Individual Voice Call Service (0001 <sub>2</sub> )	1 <sub>2</sub>	BCD (0010 <sub>2</sub> )	0 <sub>2</sub> (N/A)	PSTNI	MS Address
Voice Call from Individual MS to PABX	Send PABX dialling information from MS	Individual Voice Call Service (0001 <sub>2</sub> )	1 <sub>2</sub>	BCD (0010 <sub>2</sub> )	0 <sub>2</sub> (N/A)	PABXI	MS Address
Voice Call from MS to Individual MS	Inbound NMEA information from Source MS	Individual Voice Call Service (0001 <sub>2</sub> )	1 <sub>2</sub>	NMEA (0101 <sub>2</sub> )	0 <sub>2</sub> (N/A)	Destination MS	MS Address
Short Data call from MS to MS	Short Data Inbound Phase	Indiv" Short Data (0100 <sub>2</sub> )	0 <sub>2</sub>	UDT_Format	0 <sub>2</sub> (N/A)	Destination MS	Source MS
NMEA polling from a gateway	Short Data Inbound Phase	UDT Short data polling serv" (0111 <sub>2</sub> )	0 <sub>2</sub>	NMEA (0101 <sub>2</sub> )	0 <sub>2</sub> (N/A)	Destination MS	A TSCC Gateway



UDT Inbound channel Mechanism							
Service	Operation	Service_Kind	UDT Inbound channel information elements				
			Supplementary_Flag	Format	UDT Response	Target address or gateway	Source Address or gateway
Call Diversion Service	Diversion Inbound phase	Call Diversion serv" (0110 <sub>2</sub> )	0 <sub>2</sub>	value	0 <sub>2</sub> (N/A)	DIVERTI	MS
Authentication	Inbound MS Authentication	Authentication serv"	0 <sub>2</sub>	AUTH (0111 <sub>2</sub> )	0 <sub>2</sub> (N/A)	AUTHI	MS
IP Address registration	Inbound IP address	Registration Service	1 <sub>2</sub>	IP (0110 <sub>2</sub> )	0 <sub>2</sub> (N/A)	TSI	MS

The Key protocol aspects of the information element settings in the UDT Header feature elements are:

UDT_Format	specifies the format of the data transported in the appended data blocks of the multi-block UDT
Appended_Blocks	specifies the number of appended data blocks concatenated to the header
Supplementary_Flag	specifies if: <ul style="list-style-type: none"> <li>- this UDT Header is carrying the data for a user initiated service (Short Data, Data Polling); or</li> <li>- this UDT Header is carrying supplementary_user data, supporting another service</li> </ul>
UDT_Response	N/A
Service_Kind	specifies the service being supported by the UDT mechanism
Target_address or Gateway	target MS address PABXI for a service to a PABX extension PSTNI for a service to the PSTN IPI for a service to an IP network
Source_address or gateway	Source MS address or gateway

## 6.6 Call procedures

Access to Tier III Services from MS shall be by random access using the random access protocol described in clause 6.2. The C\_RAND CSBK random access PDU contains all parameters necessary to signify the particular Tier III service requested.

- a) Individual Voice Call Service.
- b) Talkgroup Voice Call Service.
- c) Individual Packet Data Call Service.
- d) Packet Data Call Service for a talkgroup.
- e) Individual Short Data Delivery Service.
- f) Talkgroup Short Data Delivery Service.
- g) Call Diversion Service.
- h) Short Data Polling (from an MS) Service.
- i) Include Individual Call Service (Payload Channel only).
- j) Include Talkgroup Call Service (Payload Channel only).
- k) Registration Service (see clause 6.4).
- l) Answer Call Service.
- m) Cancel Call Service.

To support these services the Tier III protocol implements a supplementary data transport mechanism whereby data may be carried between entities to support or enhance other services.

For MS call to an MS, talkgroup or All-MS, the full source and destination address is provided in the C\_RAND PDU so a single-part call set-up procedure shall be invoked. For MS calls to destinations connected through a gateway (such as PSTN), a multi-part call procedure sets an appropriate gateway address as the destination in the C\_RAND PDU. The TSCC then demands the extended\_addressing information from the calling MS using the Unified Data Transport Service (see clause 6.5).

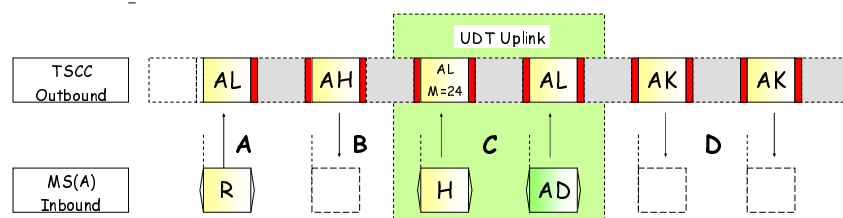

**Figure 6.38: Example of Multi-part call procedure**

Figure 6.38 shows an example of a call to a PABX extension:

- a) "A" is the random access C\_RAND PDU. The destination address is set to PABXI indicating a multi-part call setup for a call service to the PABX.
- b) "B" is a C\_AHOY PDU from PABXI to ask the calling MS for the PABX extension digits.
- c) The UDT inbound channel "C" contains a multi-block UDT consisting of a header and an appended data block containing the PABX extension digits.
- d) The TSCC sends the Channel Grant PDUs to the MS at "D".

The procedures for Voice and packet data are specified in clauses 6.6.2 and 6.6.3 respectively. The procedures include:

- e) Call Setup:
  - 1) random Access Call Request;
  - 2) possible AHOY/UDT procedure to provide extended addressing for calls through gateways;
  - 3) availability check to called party;
  - 4) Channel Grant.
- f) Call Management on the payload channel:
  - 1) call maintenance;
  - 2) call clear-down.

## 6.6.1 Procedures common to Voice calls and Packet Data Calls

### 6.6.1.1 MS Availability Checks

#### 6.6.1.1.1 Availability of calling MS

A MS requests a call service by transmitting a random access service request. While the call set-up is in progress, the TSCC may check that the requesting MS is still in radio contact at any time by sending a C\_AHOY PDU addressed to it. The C\_AHOY PDU demands a response from the calling MS.

### 6.6.1.1.2 Availability of called party as part of a call

The TSCC may check that the called party is in radio contact either during a call set-up by sending an AHOY PDU. If the message is sent by the TSCC the PDU is a C\_AHOY. If the message is sent by a TS on a payload channel the PDU is a P\_AHOY. A called party check may be addressed to an individual MS or a talkgroup. If the called party check is addressed to an individual MS, that MS shall respond with an appropriate acknowledgement. If the called party check is addressed to a talkgroup, all members of the talkgroup shall send an appropriate acknowledgement. In this case, one or a multiplicity of MSs may acknowledge this message. It is unlikely that the TS could recover any particular message but this is a useful feature because it identifies to the TS that at least one talkgroup is listening on that channel.

### 6.6.1.1.3 General MS radio check

In addition to the Calling MS and called party radio checks sent as part of a call set-up, the AHOY message may be sent by the TS at any time to check if a MS address or talkgroup is listening. The simple radio check AHOY is described in clause 6.4.12.

## 6.6.1.2 Call Cancellation

If a Voice call or Packet Call service request has been passed to the MS CC layer, and the call is cancelled before the Random Access PDU has been transmitted to the TSCC, the MS shall return to the idle state.

### 6.6.1.2.1 Cancelling a OACSU Call

If a MS has initiated a voice call service and the call has not matured (by the transmission of Channel Grant PDUs) the call may be cancelled by the calling party initiating a Call Cancel Service request. This is a random access service request (Service\_Kind=1111<sub>2</sub> Cancel Call Request). The TSCC response to a call cancel request shall be C\_ACKD (Reason=Message accepted).

### 6.6.1.2.2 Cancelling a FOACSU Call

If a FOACSU voice call service has been initiated and the call has not matured (by the transmission of Channel Grant PDUs) the call may be cancelled by the procedures prescribed in this clause.

If the call was initiated by a MS the call may be cancelled by the calling party initiating a Call Cancel Service request. This is a random access service request (Service\_Kind=1111<sub>2</sub> Cancel Call Request).

**Table 6.29: C\_AHOY information elements to cancel a FOACSU call**

Service_Options_Mirror	7	000 0000 <sub>2</sub>
Service_Kind_Flag	1	0 <sub>2</sub> Indicates that the target is an Individual Address
Ambient Listening Service	1	0 <sub>2</sub> - Not Applicable
IG	1	0 <sub>2</sub> - The Target address is an MS individual ID
Appended_Blocks	2	00 <sub>2</sub>
Service_Kind	4	Cancel Call Service - 1111 <sub>2</sub> Service_Kind_Flag - 0 <sub>2</sub>
Target address	24	Individual Address of Called MS
Source Address or Gateway	24	Individual Address of Calling MS or Gateway

The FOACSU procedure sends an AHOY(Service\_Kind\_flag=1<sub>2</sub>) to the called MS to indicate that this call is FOACSU. If the called MS responds with an acknowledgement that it will accept that call, the called MS alerts the user of the incoming call. If the call is subsequently cancelled before the called party is RFC then:

- The TSCC shall cancel the call by transmitting a C\_AHOY(Service\_Kind=1111<sub>2</sub>) to the called MS. The Information Elements are as prescribed in table 6.29.
- On receipt of the C\_AHOY(Service\_Kind=1111<sub>2</sub>) the called MS shall respond with C\_ACKU(MS\_Accepted), cancel the alert and assume the TSCC has abandoned the call.
- If the call was originated from a MS, the TSCC shall then send an acknowledgement C\_ACKD(Message Accepted) to the calling MS that the call is cancelled.

### 6.6.1.3 Acknowledgements sent to calling MS

From the point at which a MS has requested a particular service, the TSCC may send acknowledgement PDUs to indicate to the calling MS the progress of the service request.

- a) The TSCC may send PDUs that complete or terminate the call service request as follows:
  - 1) The TSCC may send C\_NACKD to indicate to the calling MS that the call has failed. The C\_NACKD PDU contains a Reason code to indicate to the caller why the service request failed.
  - 2) The TSCC may send a UDT header + appended UDT block to indicate that the call is diverted. From the TSCC perspective the service transaction is completed. The MS may choose to indicate the diverted address to the caller and return to the idle state, or automatically make a new service request with the diverted address as the destination.
  - 3) The TSCC may send C\_ACKD(Mirrored\_Reason=Callback) to inform the calling MS that the caller has indicated they will call back.
- b) The TSCC may send progress PDUs to the calling MS as a valid response to the random access request as follows:
  - 1) C\_WACKD - An intermediate acknowledgement, more signalling to follow.
  - 2) C\_QACKD - The TSCC has queued the call because the resource requested or called party is busy, more signalling to follow.
  - 3) C\_AHOY - The TSCC has sent a C\_AHOY PDU with the calling MS address in either the Source or Target address information element.

### 6.6.1.4 Called Party Answering Mechanism

The TSCC may process individual voice and packet data calls using either OACSU or FOACSU.

A call using OACSU allocates a payload channel as soon as the resource is available to connect that channel. Channel Grant PDUs are sent to the calling and called party. When the called party has successfully received the Channel Grant the user may be alerted to the incoming call.

A call using FOACSU checks that the called party is available but the Channel Grant PDUs are not sent by the TSCC until the called party indicates RFC (perhaps by an off hook mechanism). Figure 6.39 illustrates the process.

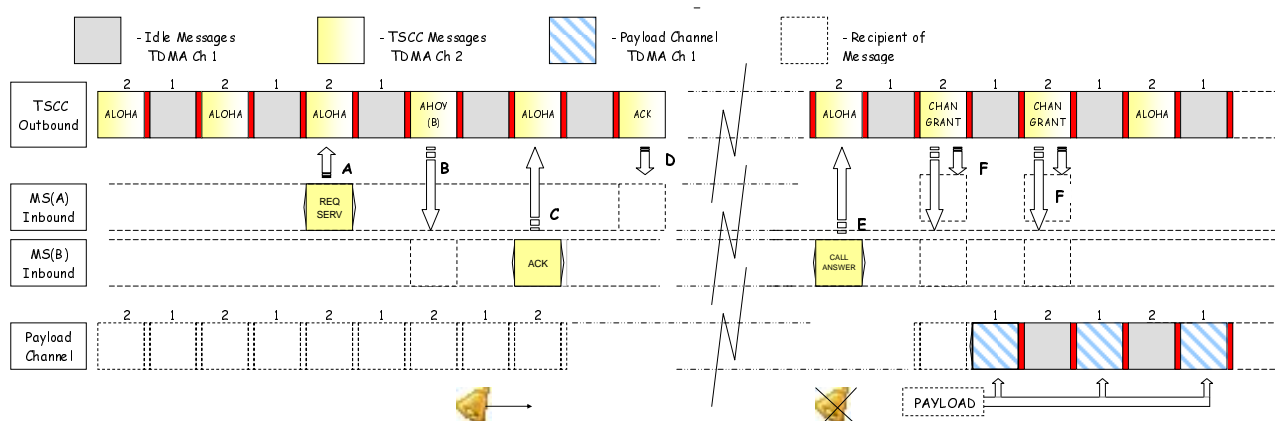

Figure 6.39: Call Answer Mechanism for FOACSU

MS(A) makes a Service Request at point "A". In this example, the TSCC sends an AHOY PDU (point "B") addressed to MS(B) that requires an acknowledgement response. The AHOY sets the Service\_Kind\_Flag= $1_2$  to indicate that the call set up is by FOACSU. MS(B) responds with an acknowledgement at point "C" and this is mirrored back to MS(A) at point "D". At this point MS(B) alerts the user of the incoming call and the receipt of the mirrored acknowledgement to MS(A) indicates that MS(B) is alerting. When the called party is RFC then:

- a) the called party user actively answers the call at point "D" causing MS(B) to send an Answered Random Access Request to the TSCC. The Alert state is cancelled;
- b) if a traffic channel resource is available, the TSCC sends a Channel Grant PDUs addressed to MS(A) and MS(B), (otherwise the TSCC may queue the call until a traffic channel becomes available).

#### 6.6.1.4.1 TSCC response to the Call Answer Random Access

When a Call Answer random access service PDU is received on the TSCC, the TSCC shall send a response in accordance with the random access procedures prescribed in clause 6.2.

The PDUs that represent a valid response to the voice call single-part service random access request are:

- a) If the MS indicates that the call is accepted (ACCEPT =  $0_2$ ):
  - 1) an acknowledgement C\_WACKD, call is queued, more signalling to follow;
  - 2) an acknowledgement C\_NACKD, system failure, message rejected;
  - 3) Channel Grant PDU(s) for this call.
- b) If the MS indicates that the call is rejected (ACCEPT =  $1_2$ ):
  - 1) an acknowledgement C\_NACKD, system failure, message rejected;
  - 2) an acknowledgement C\_ACKD, message accepted.

#### 6.6.1.4.2 Call Party Answer behaviour for the MS

A MS indicates that it is RFC by sending a C\_RAND random access request complying with the random access procedures in clause 6.2. The information elements in the random access request are passed to the CC layer - set appropriately as prescribed in table 6.30. The ACCEPT information element indicates if the called party wishes to accept ( $0_2$ ) or reject ( $1_2$ ) the call.

Table 6.30: C\_RAND information elements for the Answer Call Service

Information Element (I.E)	I.E Length	length	Alias	Value	Remark
Service_Options	7	1	EMERG	0 <sub>2</sub>	
		1		0 <sub>2</sub>	Privacy (see note 1)
		1	SUPED_SV	0 <sub>2</sub>	Not Applicable
		1	BCAST_SV	0 <sub>2</sub>	
		1	OVCM_SV	0 <sub>2</sub>	
		2	PRIORITY_SV	00 <sub>2</sub>	
Proxy Flag	1		PROXY	0 <sub>2</sub>	
Reserved	2			00 <sub>2</sub>	
Accept/Reject	1		ACCEPT	0 <sub>2</sub>	The user has accepted this FOACSU call
				1 <sub>2</sub>	The user does not wish to accept this call
Reserved	1			0 <sub>2</sub>	
Service_Kind	4		CALL_ANS	1001 <sub>2</sub>	Call Answer Service
Target_address or Gateway	24			Value	Target Address (see note 2)
Source_address	24			Value	Individual Address of the requesting MS
NOTE 1: Privacy is not defined in the present document.					
NOTE 2: Target_Address represents an Individual address.					

### 6.6.1.5 Maintenance of call progress waiting timers

#### 6.6.1.5.1 Call waiting timer for the calling MS

From the point at which a MS has requested a particular service, the TSCC may send acknowledgement PDUs to indicate to the calling MS the progress of the service request. If the calling MS receives an acknowledgement to its random access request, it shall start one of two timers. The timer TP\_Timer shall be started for a voice or packet data random access service request that requires the allocation of a payload channel. The timer TNP\_Timer shall be started for a call that only uses the TSCC for the call. If, while the timer is running the MS receives repeat acknowledgement PDU or a C\_AHOY PDU applicable to that call, the timer shall be refreshed. If the timer expires, the MS may assume that the TSCC has abandoned the call and the MS shall return to the idle state.

The TSCC shall maintain an identical timer. If the TSCC receives a random access request for a call that requires the allocation of a payload channel, it will start timer TP\_Timer. A call that only requires the TSCC shall start timer TNP\_Timer. The TSCC may send a further acknowledgement to the calling MS and refresh its timer. If the timer expires, the TSCC shall abandon that call service.

#### 6.6.1.5.2 Call waiting timer for the called MS

If a MS receives an individually addressed C\_AHOY PDU (Service\_Kind=0000<sub>2</sub>, Service\_kind\_Flag=0<sub>2</sub>) or C\_AHOY PDU (Service\_Kind=0010<sub>2</sub>, Service\_Kind\_Flag=0<sub>2</sub>) indicating an OACSU availability check for a payload channel, the MS shall start timer T\_Pending.

If a MS receives an individually addressed C\_AHOY PDU (Service\_Kind=0000<sub>2</sub>, Service\_Kind\_Flag=1<sub>2</sub>) or C\_AHOY PDU (Service\_Kind=0010<sub>2</sub>, Service\_Kind\_Flag=1<sub>2</sub>) indicating a FOACSU availability check for a payload channel, the MS shall start timer T\_AnswerCall.

While the applicable T\_Pending or T\_AnswerCall timer is running, if the MS receives a Talkgroup voice channel grant or Packet Data Talkgroup Channel Grant PDU, the PDU shall be discarded.

If the applicable T\_Pending or T\_AnswerCall timer expires and the MS has not been directed to a payload channel, the MS may assume that the TSCC has abandoned the call that was indicated in the C\_AHOY PDU. If the call set up is FOACSU, the MS shall be alerting and expiry of T\_AnswerCall shall cancel the MS alerting state.

If while the applicable T\_Pending or T\_AnswerCall timer is running, the TSCC transmits another individually addressed C\_AHOY PDU (Service\_Kind=0000<sub>2</sub>) or C\_AHOY PDU (Service\_Kind=0010<sub>2</sub>), the MS shall refresh the appropriate timer.

If while the applicable T\_Pending or T\_AnswerCall timer is running, the TSCC transmits an individually addressed C\_AHOY call cancellation PDU C\_AHOY (Service\_Kind=1111<sub>2</sub>), the timer shall be suspended. The MS shall assume that the TSCC has abandoned the call.

The TSCC shall maintain the same timer T\_Pending and T\_AnswerCall. If the TSCC transmits a C\_AHOY PDU (Service\_Kind=0000<sub>2</sub>, Service\_Kind\_Flag=0<sub>2</sub>) or C\_AHOY PDU (Service\_Kind=0010<sub>2</sub>, Service\_Kind\_Flag=0<sub>2</sub>), indicating an availability check for a payload channel, T\_Pending is started. If the TSCC transmits a C\_AHOY PDU (Service\_Kind=0000<sub>2</sub>, Service\_Kind\_Flag=1<sub>2</sub>) or C\_AHOY PDU (Service\_Kind=0010<sub>2</sub>, Service\_Kind\_Flag=1<sub>2</sub>) indicating an availability check for a payload channel, T\_AnswerCall is started.

If the TSCC has not transmitted the Channel Grant PDU(s) for this call before T\_Pending or T\_AnswerCall expires, the TSCC shall abandon the call.

If an applicable Channel Grant is sent/received, the applicable T\_Pending or T\_AnswerCall timers in the TSCC and MS shall be suspended.

### 6.6.1.6 Payload Channel Assignment

The TSCC shall assign a payload channel for the call by transmitting applicable Channel Grant PDUs for the service supported (individual MS or talkgroup).

The Channel Grant PDUs may be single block CSBK format if the logical channel to absolute Tx / Rx frequency relationship is known, or the MBC Channel Grant PDUs may have an appended MBC block that contains the absolute Tx /Rx frequencies.

For individual voice and packet data services to and from certain gateways, the payload channel may select offset timing to provide a full duplex service to MS. The TSCC provides a differing gateway identifier to distinguish between the aligned and offset mode of payload assignment:

- a) for aligned timing PSTNI, PABXI, LINEI, IPI, DISPATI (see clause A.4);
- b) for offset timing PSTNDI, PABXDI, LINEDI, IPDI, DISPATDI (see clause A.4).

Channel Grant PDUs may be transmitted by the TS on a payload channel to swap the call to a replacement channel.

If a particular talkgroup call is active on a payload channel, the TSCC may continue to transmit appropriately addressed Channel Grant PDUs at regular intervals to permit late joining MSs (MSs who may have just arrived on the control channel) to join that talkgroup call.

### 6.6.1.7 Calls to ALLMSID, ALLMSIDL and ALLMSIDZ

The present document prescribes calls to All MS.

A MS may request a call to ALLMSID, ALLMSIDL or ALLMSIDZ. (See clause A.4.)

A call to ALLMSID shall be treated as a broadcast call to a talkgroup and is directed to all MS on all radio sites in a particular system.

A call to ALLMSIDZ shall be treated as a broadcast call to a talkgroup and is directed to specific radio sites in a particular system. The choice of radio sites included in this call is manufacturer specific.

A call to ALLMSIDL shall be treated as a broadcast call to a talkgroup and is directed to all MS restricted to the radio site of which the call was initiated.

It is expected that a MS initiating a All MS call set the information elements in the C\_RAND PDU correctly to identify the call as a broadcast to a talkgroup.

## 6.6.2 Voice Call Procedures

Voice calls require a payload channel over which the call is conducted. Calls may be transacted between the entities in table 6.31.

**Table 6.31: Voice Call Services**

Mode	Originator	Recipient
	MS	MS or Talkgroup
	MS	All MS (Broadcast)
	MS	Line Connected destination through a Gateway: PABX Extension PSTN destination Other gateway equipped for voice
	Line Connected source via a Gateway: PABX Extension PSTN destination Other gateways equipped for voice	MS or Talkgroup or All MS

The Individual/Talkgroup PDU in the Random Access Service Request shall determine if the caller has selected a Tier III service to an individual MS or a talkgroup.

The Service\_Options PDU in the Random Access Service Request shall activate options for the Voice Call Service Request:

- Emergency service:
  - Emergency calls shall take precedence over all other calls. Emergency call may be pre-emptive causing another call to be cleared down if the resource requested for the emergency call is not available.
- Supplementary\_user data Transfer Service requested for this call:
  - Information may be sent to the called party as part of and to support another call service. For instance the PSTN Call Line Identity may be passed to the called party as part of a voice call setup.
- Broadcast service:
  - The Broadcast Call Voice service provides a one-way voice call from any user to a predetermined talkgroup.
- OVCM call:
  - The Open Voice Channel Mode service allows users to monitor and participate to the voice channel activity. From the voice activity originator's point of view the OVCM gives the opportunity to place group and individual calls that may be listened from third party users that are not the targeted users of the call. In addition these third party users are part of the conversation in progress and they can also talk.
  - Third party users are those that have radios configured to take part to calls set as OVCM and not addressed explicitly to them.
- Priority:
  - The priority option permits the originator to select one of four levels of priority. The TSCC may manage and manipulate a call queue to cause calls with a higher priority to mature faster. The procedures the TSCC may employ are not prescribed in the present document.
- Call to All MS:
  - A voice call may be made to all MS. In this case, the MS or Gateway selects the Identifier ALLMSID, ALLMSIDL, or ALLMSIDZ (see clause A.4) as the destination address. The call shall use the Broadcast Service



### 6.6.2.1 Voice Call Procedures for the TSCC

A MS requests a Tier III voice service by generating a random access request PDU with the Target Address set to one of the following:

- a) an individual MS address (single-part call set-up);
- b) a talkgroup MS address (single-part call set-up);
- c) a gateway address that indicates a multi-part call set-up. The gateway address indicates the destination e.g. PABXI for a call to a PABX, PSTNI for a call to the PSTN, LINEI for a call to a line connected destination, DISPATI for a call to the system dispatcher. For flexibility calls to line connected destinations and the system dispatcher, such calls are treated in the same way as PABX/PSTN calls.

When the TSCC responds to the random access request, it shall start a timer (TP\_Timer). This timer shall be refreshed if the TSCC sends further call related PDUs C\_WACKD, C\_QACKD or C\_AHOY, to the calling party.

#### 6.6.2.1.1 TSCC Response to single-part voice call set-up

When a random access voice service PDU is received on the TSCC, the TSCC shall send a response in accordance with the random access procedures prescribed in clause 6.2.

The PDUs that represent a valid response to the voice call single-part service random access request are:

- a) An acknowledgement PDU C\_NACKD, C\_QACKD, C\_WACKD, C\_ACKD(mirrored\_reason=callback).
- b) A UDT Head + appended block(s) (voice call is diverted) UDT Header PDUs Source\_Address=DIVERTI (conveying a diverted address) Supplementary Flag = 1<sub>2</sub> and UDT\_Response = 0<sub>2</sub>.
- c) A C\_AHOY PDU from the calling party MSID (called party radio check) if the call is to an individual MS address. (C\_AHOY Source address=calling party MS ID, Destination address=called party MS ID) (see clause 6.6.2.1.4).
- d) A C\_AHOY PDU, Source Address=Authentication Challenge Value (MS authentication check) (see clause 6.4.8.2).
- e) A C\_AHOY PDU from SUPLI for the calling MS to send supplementary\_user data (see clause 6.4.13).
- f) A Channel Grant PDU(s) for this call.

For e) the TSCC shall then invoke the UDT procedure by sending the C\_AHOY to the calling MS to send the supplementary\_user data. The format of the supplementary\_user data is specified in the UDT. If the TSCC does not successfully receive the UDT from the MS, the TSCC may repeat the C\_AHOY, or transmit a C\_NACKD to indicate failure of the call, or continue with the call setup and abandon the supplementary\_user data.

The order in which c) d) and e) shall be sent is prescribed in clause 6.4.13.

NOTE: A TSCC may send a C\_AHOY addressed to a talkgroup to check that at least one member of the talkgroup is listening to the TSCC.

The purpose of the C\_AHOY PDU in c), d) and e) is identified by the source address information element in the C\_AHOY PDU. For a called party check it is the called party MS ID or talkgroup. For an authentication check it is the gateway address AUTHI. For e) it is SUPLI.

#### 6.6.2.1.2 TSCC Response to multi-part voice call set-up

For calls to extended\_addresses, the MS requests multi-part addressing by generating a voice call random access request with the Destination Address information element set to a gateway address (PABXI, PSTNI, etc.) and the Proxy Flag information element to indicate if one or two appended UDT blocks are required to transport the extended\_address from the MS. For calls to the PABX/PSTN/LINE/dispatcher one appended UDT can carry up to 20 dialled digits, and in that case the Proxy Flag information element shall be set to 0<sub>2</sub>, and for the number of dialled digits = 21 to 44 the Proxy Flag information element shall be set to 1<sub>2</sub>.

The PDUs that shall represent a valid response to the voice call multi-part part voice service random access request are:

- a) An acknowledgement PDU C\_NACKD, C\_WACKD, C\_QACKD.
- b) A C\_AHOY PDU from PABXI, PSTNI, LINEI, DISPATI for the calling MS to send the extended\_address information.
- c) A C\_AHOY PDU from SUPLI for the calling MS to send supplementary\_user data (see clause 6.4.13).

For b) the TSCC shall then invoke the UDT procedure by sending a C\_AHOY to the calling MS to send the extended\_address information. For a call to the PABX, PSTN, LINEI or DISPATI the extended\_address information shall be BCD digits. The Proxy Flag information element in the C-AHOY PDU shall be copied from the Proxy Flag information element received from the MS C\_RAND PDU. If the TSCC does not successfully receive the UDT from the MS, the TSCC may repeat the C\_AHOY, or transmit a C\_NACKD to indicate failure of the call.

For c) the TSCC shall then invoke the UDT procedure by sending the C\_AHOY to the calling MS to send the supplementary\_user data. The format of the supplementary\_user data is specified in the UDT. If the TSCC does not successfully receive the UDT from the MS, the TSCC may repeat the C\_AHOY, or transmit a C\_NACKD to indicate failure of the call, or continue with the call setup and abandon the supplementary\_user data.

#### 6.6.2.1.3 Acknowledgements sent by the TSCC to the calling MS (voice)

The TSCC may send acknowledgement PDUs following the random access voice service request to indicate the progress of the call, to terminate the call or indicate call-back. If the TSCC sends a PDU to indicate the progress of a call it shall start a waiting timer TP\_Timer. (The calling party MS maintains a similar timer):

- a) Progress PDUs are:
  - 1) C\_WACKD: Intermediate acknowledgement. More PDUs to follow;
  - 2) C\_QACKD: Called MS engaged in another call;
  - 3) C\_QACKD: Call is queued because the resource is in use at the moment.
  - 4) If the call is FOACSU, C\_ACKD(Mirrored\_Reason=MS\_ALERTING) to indicate to the calling party that the called party is alerting (sent an acknowledgement to the C\_AHOY Service\_Kind=0000<sub>2</sub> Service\_Kind\_Flag=1<sub>2</sub>).
- b) Termination PDUs are selected from an appropriate Reason information element in a C\_NACKD PDU (see clause 7.2.8):
  - 1) C\_NACKD.
- c) Call-Back PDUs indicate to the calling MS that the voice call service has been accepted by the called party for call back:
  - 1) C\_ACKD(mirrored\_reason=CallBack).
- d) If the TS has previously accepted a call diversion indicating that this type of service request should be directed to another called party, the TSCC shall invoke the UDT and send a UDT Head + Appended data to the calling party. UDT Header PDUs Source Address=DIVERTI (conveying a diverted address) Supplementary Flag = 1<sub>2</sub> and UDT\_Response = 0<sub>2</sub>.

#### 6.6.2.1.4 Voice Radio Check

For calls to individual MS, the TSCC shall check that the called party is in radio contact and will accept the call before a payload channel is allocated.

The TSCC may check availability of the called party by:

- a) Sending a C\_AHOY PDU to that called party. If the message C\_AHOY Service\_Kind=0000<sub>2</sub> Service\_Kind\_Flag=0<sub>2</sub> then the TSCC is checking that the MS is in radio contact and can accept this call immediately. If the message C\_AHOY Service\_Kind=0000<sub>2</sub> Service\_Kind\_Flag=1<sub>2</sub> then the TSCC is checking that MS is RFC.
- b) Sending a Multi-block UDT with supplementary\_user data (if the supplementary\_user data service is active for this call).

If b) is sent, b) shall follow a). (See clause 6.4.13).

If a response is not received from the called party the TSCC may repeat the C\_AHOY.

The availability check demands a response from the called party:

- If the response is C\_NACKU, the TSCC shall send an appropriate call failed response to the calling MS and echo the Reason in the C\_NACKU PDU (mirrored\_reason).
- If the response is C\_ACKU(Reason=CallBack), the TSCC shall send an appropriate CallBack response to the calling MS, C\_ACKD (mirrored\_reason= 0100 0101<sub>2</sub>).
- If the response is C\_ACKU(Reason=Message\_Accepted), the TSCC shall progress the service request and allocate a payload channel by transmitting appropriate Channel Grant PDUs.
- If the called MS is FOACSU enabled, a valid response to C\_AHOY Service\_Kind=0000<sub>2</sub> Service\_Kind\_Flag=1<sub>2</sub> is C\_ACKU(Reason= MS\_ALERTING), i.e. MS alerting but not yet RFC.

NOTE: A multi-block UDT cannot transfer all Service Options to the called party. If the Service Options are essential to the operation of the system, a C\_AHOY/response and a Multi\_block UDT/response may be sent to the MS.

#### 6.6.2.1.5 Availability Check for Voice Calls connected through Gateways

For calls connected through gateways the TS equipment may wait until the destination is RFC before allocating the payload channel. For example a TS may wait until the PSTN handset has been answered before sending Channel Grant PDUs.

#### 6.6.2.2 Voice Call Procedures for MS

A MS is able to request a voice call service to another individual MS or a talkgroup using a single-part service request. For a voice service requested to extended\_addresses through a gateway the MS requests a multi-part service request. For multi-part service requests the MS sets the gateway address as the called party. The full destination address is then uploaded from the MS to the TSCC by the UDT procedure.

A MS requests a voice service by sending a C\_RAND random access request complying with the random access procedures in clause 6.2. The information elements in the random access request are passed to the CC layer - set appropriately as prescribed in table 6.32.

Table 6.32: C\_RAND information elements for a Voice Call Service

Information Element (I.E)	I.E Length	length	Alias	Value	Remark	
Service_Options	7	1	EMERG	0 <sub>2</sub>	Non-emergency service	
				1 <sub>2</sub>	Emergency service	
		1			0 <sub>2</sub>	Privacy (see note 1)
					1 <sub>2</sub>	
		1	SUPED_SV		0 <sub>2</sub>	No Supplementary_user data Transfer Service required for this call
					1 <sub>2</sub>	Supplementary_user data Transfer Service requested for this call
		1	BCAST_SV		0 <sub>2</sub>	Non-broadcast service
					1 <sub>2</sub>	Broadcast service (see note 2)
		1	OVCM_SV		0 <sub>2</sub>	Non-OVCM call
					1 <sub>2</sub>	OVCN call
		2	PRIORITY_SV (see note 3)		00 <sub>2</sub>	Normal (low) priority
					01 <sub>2</sub>	Medium Priority
10 <sub>2</sub>	High Priority					
11 <sub>2</sub>	Highest Priority					
Proxy Flag	1		PROXY	0 <sub>2</sub>	Number of Extended BCD digits for addressing through a gateway = 1 to 20	
				1 <sub>2</sub>	Number of Extended BCD digits for addressing through a gateway = 21 to 44	
Appended_Supplementary_Data	2		SUPED_VAL	Value	Number of appended UDTs required to transport supplementary_user data	
Ambient Listening Service	1		ALS_SERV	0 <sub>2</sub>	Ambient Listening Service not requested	
				1 <sub>2</sub>	Ambient Listening Service requested	
Reserved	1			0 <sub>2</sub>		
Service_Kind	4		IND_V_SRV	0000 <sub>2</sub>	Individual Voice Call Service	
			GRP_V_SRV	0001 <sub>2</sub>	Talkgroup Voice Call Service	
Target_address or Gateway	24			Value	Target Address (see note 4)	
Source_address	24			Value	Individual Address of the requesting MS	
NOTE 1: Privacy is not defined in the present document.						
NOTE 2: The broadcast option is only applicable to the talkgoup call service.						
NOTE 3: If EMERG = 1 <sub>2</sub> then PRIORITY_SV is set to 00 <sub>2</sub> .						
NOTE 4: If Service_Kind = IND_V_SRV then Target_Address represents an Individual address. If Service_Kind = GRP_V_SRV then Target_Address represents a Talkgroup.						
NOTE 5: OVCM calls apply to MS destinations only.						
NOTE 6: If SUPED_SV = 0 <sub>2</sub> then SUPED_VAL = 00 <sub>2</sub> .						

#### 6.6.2.2.1 Initiating a single-part voice call service

For a voice service request to an individual MS or talkgroup, the destination address is completely expressed by the Target Address information element in the random access PDU. The Service\_Kind specifies if the voice call service is addressed to an individual address or a talkgroup.

#### 6.6.2.2.2 Response to the single-part voice service request

MS shall accept the following PDUs as valid response to the single-part voice service request.

- a) an acknowledgement C\_WACKD, C\_QACKD, C\_NACKD, C\_NACKD(mirrored\_reason), C\_ACKD(mirrored\_reason=callback);
- b) a C\_AHOY called party radio check;

- c) a UDT header + appended UDT block. UDT Header Source\_Address=DIVERTI (conveying a diverted address) Supplementary Flag = 1<sub>2</sub> and UDT\_Response = 0<sub>2</sub>;
- d) a Channel Grant PDU;
- e) if the Service\_Options SUPED\_SV = 1<sub>2</sub> a C\_AHOY from SUPLI to upload the supplementary\_user data from the calling MS.

#### 6.6.2.2.3 Response to the multi-part voice service request

MS shall accept the following PDUs as valid response to the multi-part voice service request.

- a) an acknowledgement C\_WACKD, C\_QACKD, C\_NACKD;
- b) a C\_AHOY PDU from PABXI,PSTNI,LINEI, DISPATI to upload the extended\_address:
  - 1) for a call to the PABX/PSTN/LINEI/DISPATI a C\_AHOY to upload the dialled digits;
  - 2) if the Service\_Options SUPED\_SV = 1<sub>2</sub> a C\_AHOY from SUPLI to upload the supplementary data from the calling MS.

For b), if the Voice Call Service Request requires extended\_address information and the calling MS has selected the Supplementary Data in the Service\_Options, the TSCC uploads the information in two steps. The order in which the information is uploaded is not prescribed because the C\_AHOY specifically indicates which UDT inbound procedure has been invoked by setting appropriate unambiguous Gateway information elements in the C\_AHOY PDU. The gateway information elements for C\_AHOY PDUs to support voice services are prescribed in table 6.33.

**Table 6.33: C\_AHOY information elements for multi-part voice call setup**

Action	Gateway address	Remark
MS send PSTN digits	PSTNI	The calling party shall send BCD dialled digits
MS sends PABX digits	PABXI	The calling party shall send BCD dialled digits
MS sends digits to the line	LINEI	The calling party shall send BCD dialled digits
MS sends digits to dial the dispatcher	DISPATI	The calling party shall send BCD dialled digits
MS sends supplementary_user data	SUPLI	The format of the data shall be determined by the calling party

#### 6.6.2.2.4 Acknowledgements received by the calling MS (voice)

At some time after sending the voice service request random access PDU the calling MS may receive an acknowledgement. On receiving the acknowledgement, the MS shall start or restart a waiting timer, TP\_Timer. (The TSCC maintains a similar timer.)

The MS shall take the actions prescribed:

- a) Progress PDUs for a single-part voice call Service Request are:
  - 1) C\_WACKD: Intermediate acknowledgement. More PDUs to follow. The MS shall wait TP\_Timer for further signalling and may indicate a possible delay to the calling MS;
  - 2) C\_QACKD: Called MS engaged in another call. The MS shall wait TP\_Timer for further signalling;
  - 3) C\_QACKD: Call is queued because the resource is in use at the moment. The MS shall wait TP\_Timer for further signalling and may indicate a possible delay to the calling MS.

(The MS may choose to differentiate between 1), 2) and 3) by providing the calling MS with a visual or audible indication for each of the conditions.)

- b) Termination PDUs are selected from an appropriate Reason information element in a C\_NACKD PDU (see clause 7.2.8). If the call was rejected by the calling party, the termination PDU sent by the TS shall be a C\_NACKD(mirrored\_reason):
  - 1) C\_NACKD: Call refused and terminated. The C\_NACKD PDU provides a versatile range of Reason codes and mirrored reason codes to indicate to the calling party why the Service request was terminated. The calling party shall return to the idle state.
- c) Call-Back PDU to indicate to the calling MS that the voice call service has been accepted by the called party for call back. Service concluded. The calling party shall return to the idle state:
  - 1) C\_ACKD(mirrored\_reason=CallBack).
- d) If the TS has previously accepted a call diversion indicating that this type of service request be directed to another called party, a UDT Head + Appended data indicating the diverted address.

#### 6.6.2.2.5 Availability Check to the called party (voice)

For an individual MS address call set-up, the called MS shall receive a radio check to which it shall respond with an appropriate acknowledgement:

- The called party shall respond C\_NACKU, if it cannot accept the call (the TSCC shall send an appropriate call failed response to the calling MS).
- The called party shall respond C\_ACKU(Reason=CallBack), if the called MS wishes to return the call at some future time (the TSCC shall send an appropriate CallBack response (mirrored reason) to the calling MS).
- The called party shall respond C\_ACKU(Reason=MS\_Accepted), if the call is accepted and the MS can accept the call immediately (the TSCC shall progress the service request and allocate a payload channel by transmitting appropriate Channel Grant PDUs).
- If the MS is FOACSU enabled and the message to which the MS is sending the acknowledgment is C\_AHOY Service\_Kind=0000<sub>2</sub> Service\_Kind\_Flag=1<sub>2</sub> then a valid response is C\_ACKU(Reason= MS\_ALERTING), i.e. MS alerting but not yet RFC. After sending the acknowledgment the MS may indicate RFC by sending a C\_RAND (Answer Call Service, ACCEPT=0<sub>2</sub>). If the called MS is alerting but the user does not wish to accept the call the MS shall send a C\_RAND(Answer Call Service, ACCEPT=1<sub>2</sub>) to reject the call.

#### 6.6.2.2.6 Payload Channel Allocation

MS shall check the address information elements received in Voice Channel Grant PDUs. If it is determined that the Channel Grant PDU is applicable then it shall retune to the indicated physical/logical payload channel to commence the Voice Service:

- a) For Private Voice Channel Grant CSBK PDU:
  - 1) If an MS receives a Private Channel Grant PDU where either the Source Address or the Target Address information element matches its individual address then that PDU is applicable.
- b) Talkgroup Voice Channel Grant CSBK PDU (OVCM information element = 0<sub>2</sub>):
  - 1) If an MS receives a Talkgroup Channel Grant PDU with the Target Address information element matching one of its talkgroup addresses then that PDU is applicable.
  - 2) If an MS receives a Talkgroup Channel Grant PDU with the Source Address matching its individual address then that PDU is applicable.
  - 3) If an MS receives a Broadcast Talkgroup Channel Grant PDU with the Target Address matching one of its talkgroup addresses then that PDU is applicable.
  - 4) If an MS receives a Broadcast Talkgroup Channel Grant PDU with the Source Address matching its individual address then that PDU is applicable.

- c) Talkgroup Voice Channel Grant CSBK PDU (OVCM information element = 1<sub>2</sub>):
- 1) If an MS receives a Talkgroup Channel Grant PDU with the Target Address information element matching one of its talkgroup addresses or one of its OVCM addresses then that PDU is applicable.
  - 2) If an MS receives a Talkgroup Channel Grant PDU with the Source Address matching its individual address then that PDU is applicable.
  - 3) If an MS receives a Broadcast Talkgroup Channel Grant PDU with the Target Address matching one of its talkgroup addresses or one of its OVCM addresses then that PDU is applicable.
  - 4) If an MS receives a Broadcast Talkgroup Channel Grant PDU with the Source Address matching its individual address then that PDU is applicable.

### 6.6.2.2.7 Calling MS in single part voice call setup SDL

Figures 6.40 and 6.41 SDL is defined from the behaviour description in clause 6.6.2.2.

NOTE: The state names are not related to state names in TS 102 361-1 [5] and TS 102 361-2 [6].

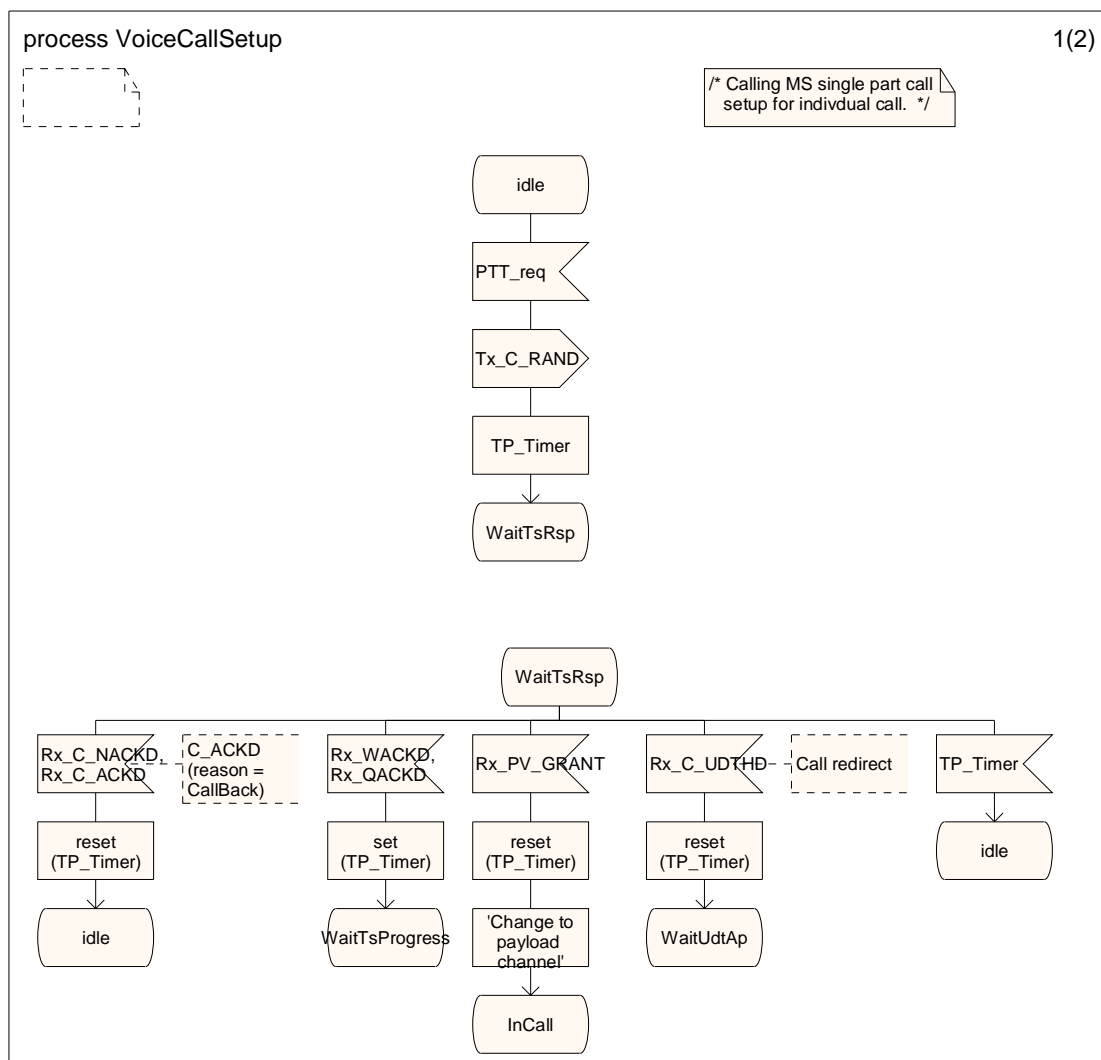

Figure 6.40 (sheet 1 of 2): Single part OACSU voice call setup SDL

process VoiceCallSetup

2(2)

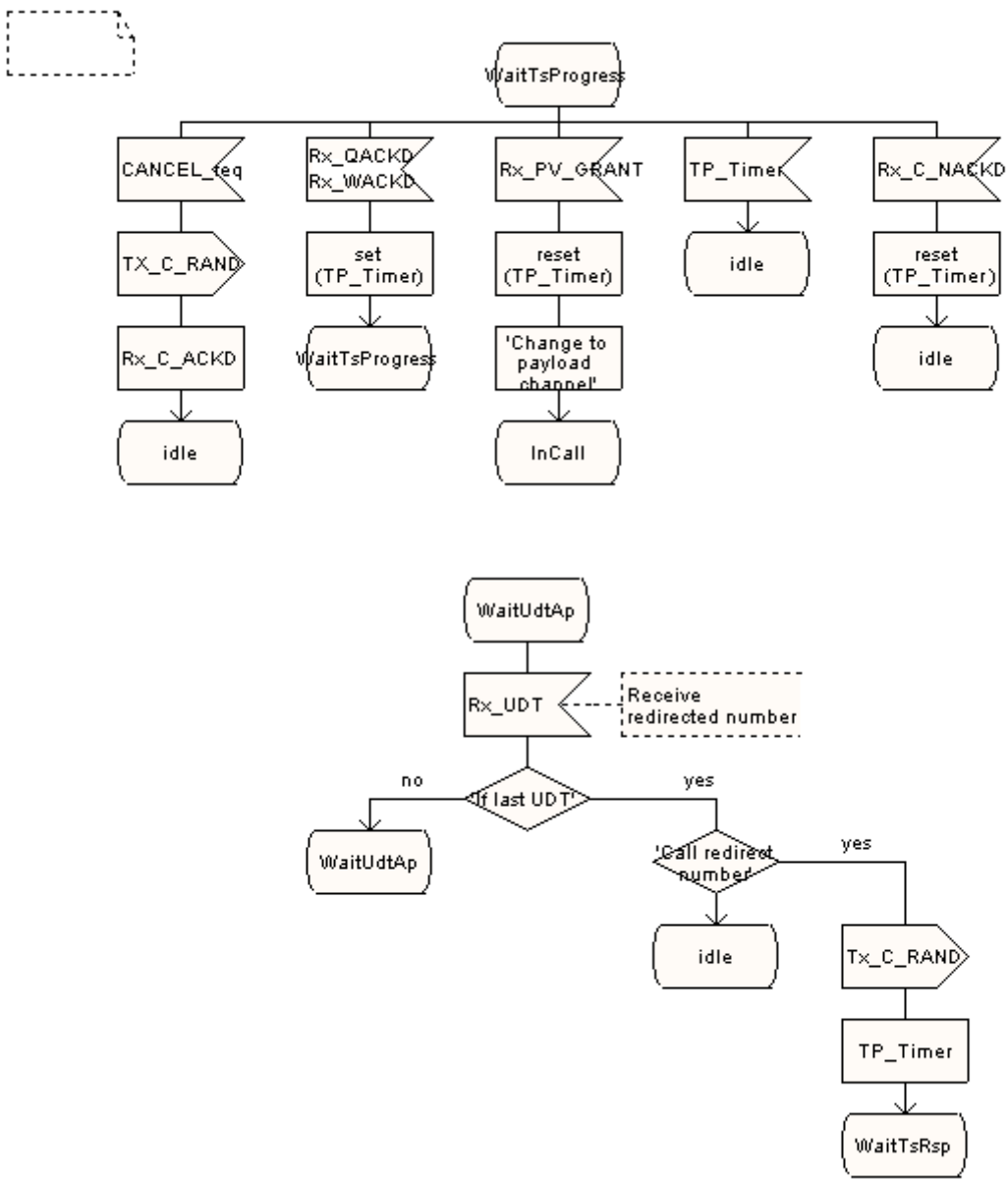

Figure 6.41 (sheet 2 of 2): Single part OACSU voice call setup SDL



### 6.6.2.2.8 Call set-up MSC that also transfers supplementary\_user data.

Figure 6.42 illustrates a call set-up from an MSC where supplementary\_user data is transferred as part of the call set-up.

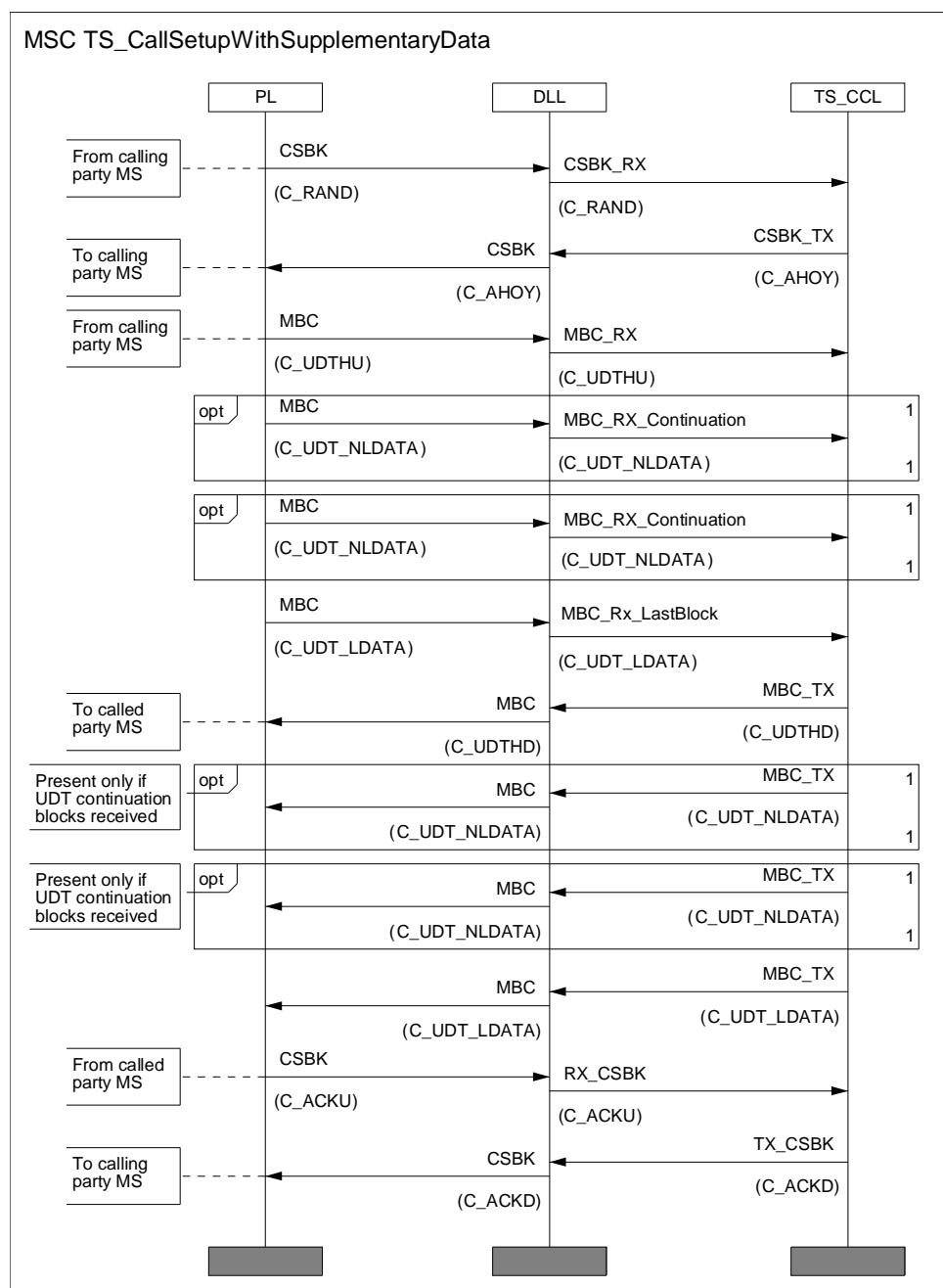

Figure 6.42: MS OACSU Call set-up with Supplementary data

### 6.6.2.3 Timing requirements for the allocation of a Payload Channel

MSs are directed to a payload physical/logical channel for voice and certain data services. Where a payload channel is allocated MS shall comply with the timing requirement defined in this clause.

If neither slot of a payload channel is active, there is no requirement that the payload channel is keyed. If at least one of the payload channel slots becomes active then the payload channel keys up:

A payload channel that is not active in a call shall send IDLE PDUs.

A payload channel that is active in a call may send:

- Payload Channel Grant
- P\_PROTECT PDUs to remove MSs that are not legitimate users of the traffic channel
- P\_CLEAR PDUs to indicate the end of the call and clear down the MSs
- P\_AHOY and P\_xACK PDU's
- Speech (or data) items received inbound
- Terminator PDUs between inbound speech (data) items

#### 6.6.2.3.1 TSCC and Payload channel are time aligned

If slot 1 on the payload channel is selected by the TS, then the MS shall be capable of receiving or transmitting information in the second occurrence of slot 1 on the payload channel after having decoded the Channel grant on the TSCC successfully.

If slot 2 on the payload channel is selected by the TS, then the MS shall be capable of receiving or transmitting information in the third occurrence of slot 2 on the payload channel after having successfully decoded the Channel Grant on the TSCC.

Independent of the payload assignment to slot 1 or 2 on the payload channel, the payload channel shall start to transmit PDUs from the list specified in clause 6.6.2.3 outbound, following the transmission of the first channel grant on the TSCC until payload for transmission is available.

#### 6.6.2.3.2 TSCC and Payload channel are not time aligned

The MS shall be capable of receiving or transmitting on the next upcoming assigned payload slot after it successfully synchronized to the outbound payload channel.

The Synchronization period shall include the occurrence of 4 CACH on the traffic channel after the first sync opportunity for the MS. This is to allow for robust TC bit decoding in fringe situations.

Independent of the payload assignment to slot 1 or 2 on the payload channel, the payload channel shall start to transmit IDLE slots on the outbound following the transmission of the first channel grant on the TSCC. These IDLE slots shall be transmitted until a minimum of 4 CACH, after the first MS Sync pattern receive opportunity, have been transmitted .Note: Depending on the actual RF coverage for the intended area to be served by the system a number of 4 CACH might be regarded as not necessary.

It is recommended to have a programmable parameter in the infrastructure and MS with a value of 2 or 4.

#### 6.6.2.4 Procedures for the Voice Payload Channel

MSs are directed to a voice payload physical/logical channel on the TSCC. When the voice call is terminated, MS returns to the TSCC and the payload channel is reassigned to another call.

A voice call may extend over several MS PTT items for the duration of the call (unless the call is terminated prematurely by the expiry of the voice payload timer) if the system has assigned the call as "message trunking". If the system has assigned the call as pure "transmission trunking" the call shall be terminated after the end of each PTT item. A third possibility is that the call has been assigned as "quasi-transmission trunking". In this case a short interval timer (TV\_Hangtime) between PTT items holds the payload channel. If this short interval timer expires, the call is terminated and the next PTT item sets up a new call.

The voice payload channel may be assigned to one of two basic timing models. The particular timing model is specified on the TSCC and signalled to MS by the Channel Grant PDUs (see TS 102 361-1 [5]):

- a) Aligned timing supports Reverse Channel (RC) signalling by providing the receiving MS with a Reverse Channel transmit opportunity on the inbound channel without missing any of its outbound traffic. Aligned timing also supports "MS to MS" duplex traffic by allowing a MS to transmit in one timeslot and receive the repeated transmission of the other MS on the alternative timeslot:
  - 1) 1:1-mode. 1 traffic channel mode: 1:1-mode supports one "MS to fixed end" duplex call or one simplex call with an optional inbound Reverse Channel using a two frequency BS.
  - 2) 2:1-mode. 2 traffic channel mode: 2:1-mode supports two independent calls which may be either "MS to fixed end" duplex calls or simplex calls using a two frequency BS.
- b) Offset timing supports "MS to fixed end" duplex traffic by allowing a MS to transmit in one time slot and receive the fixed end transmission on the alternate time slot.

The procedures for TS/MS behaviour on the voice payload channel are described in TS 102 361-2 [6]. In the trunked environment however, call maintenance PDUs are exchanged between MS and TS in addition to the PDUs described in TS 102 361-2 [6].

When active, a payload channel shall transmit the CACH in the same form as described in TS 102 361-2 [6], clause 7.1.3.2).

The beginning of a call shall use PATCS method (see TS 102 361-2 [6], clause 5.2.2.1). For an individual MS call service, the called party will already have had a radio check as part of the call set-up procedure.

#### 6.6.2.4.1 TS Procedures for the Voice Payload Channel

A physical payload channel may carry one or two independent voice calls. If a new physical channel is allocated on the TSCC, the CCL\_BS shall start both the CCL\_1 and CCL\_2 processes as described in TS 102 361-2 [6], clause 5.1.1.1.3), and start the voice channel payload timer as follows:

- a) For an individual MS/MS or MS/Talkgroup normal or high priority call T\_MS-MS\_TIMER.
- b) For a gateway individual MS or Talkgroup normal or high priority call T\_MS-Line\_TIMER.
- c) For an emergency call T\_EMERG\_TIMER.

##### 6.6.2.4.1.1 MS radio check

The TS may poll an individual MS to check if the MS is active on the payload channel by transmitting a P\_AHOY PDU with the information elements set as follows.

The TSCC transmits a P\_AHOY with the information elements as illustrated in table 6.34.

**Table 6.34: P\_AHOY information elements for voice service individual radio check**

Service_Options_Mirror	7	000 0000 <sub>2</sub>
Service_Kind_Flag	1	0 <sub>2</sub>
Ambient Listening Service	1	0 <sub>2</sub> - The calling party has not requested ALS 1 <sub>2</sub> - The calling party has requested ALS (See Note)
IG	1	0 <sub>2</sub> - The Target address is an MS individual ID
Appended_Blocks	2	00 <sub>2</sub>
Service_Kind	4	Individual Call Service - 0000 <sub>2</sub>
Target_address	24	Individual Address of Called MS
Source Address or Gateway	24	TSI

The response is P\_ACKU(Reason=Message\_Accepted).

The TS may also poll a talkgroup to check if at least one member of the talkgroup is active on the payload channel by transmitting a P\_AHOY PDU with the information elements as illustrated in table 6.35.

**Table 6.35: P\_AHOY information elements for voice service talkgroup radio check**

Service_Options_Mirror	7	000 0000 <sub>2</sub>
Service_Kind_Flag	1	0 <sub>2</sub>
Ambient Listening Service	1	0 <sub>2</sub> - Not Applicable
IG	1	1 <sub>2</sub> - The Target address is a talkgroup
Appended_Blocks	2	00 <sub>2</sub>
Service_Kind	4	Talkgroup Call Service - 0001 <sub>2</sub>
Target address	24	Address of the talkgroup
Source Address or Gateway	24	TSI

The response is P\_ACKU (Reason=Message\_Accepted). If more than one MS makes a response to this PDU, it is likely that the TS will be unable to decode it because of collisions. The purpose of this procedure is to determine if any talkgroups are active, therefore the TS may use the presence of the burst for the result of the talkgroup radio check.

NOTE: The TS may poll an individual MS or a talkgroup to check if the MS is active on the payload channel irrespective of the Call Service. This procedure is described in clause 6.4.12.

#### 6.6.2.4.1.2 Authentication Check

The authentication procedures are identical to the authentication procedures described in clause 6.4.8.2 but with the C\_AHOY PDU replaced by a P\_AHOY PDU.

#### 6.6.2.4.1.3 Disabling/enabling a users PTT

The TS may at any time send a P\_PROTECT (Protect\_Kind=DIS\_PTT) addressed to an individual MS, talkgroup, or ALLMSID to disable the PTT. Since the P\_PROTECT PDU is unacknowledged the PDU may be repeated at layer 2.

The TS may also at any time send a P\_PROTECT (Protect\_Kind=EN\_PTT) addressed to an individual MS, talkgroup, or ALLMSID to enable the PTT. Since the P\_PROTECT PDU is unacknowledged the PDU may be repeated at layer 2.

#### 6.6.2.4.1.4 Swapping the call to a replacement voice payload channel

The TS may send Channel Grant PDUs on the payload channel to move MS already active to an alternative voice payload channel. If MS had previously received a P\_PROTECT to disable their PTT, the PTT shall be re-enabled on the replacement voice payload channel unless the call service was a broadcast when called party(s) shall retain their PTT status (enable/disable) from the original call.

#### 6.6.2.4.1.5 Removing MS from the payload channel that are not legitimate parties

The TS may transmit P\_PROTECT(ILLEGALLY\_PARKED) PDUs at any time.

- a) For an individual call, if the target address transmitted by the P\_PROTECT(ILLEGALLY\_PARKED) PDUs matches the target address transmitted by the Channel Grant AND the source address transmitted by the P\_PROTECT(ILLEGALLY\_PARKED) PDUs matches the source address transmitted by the Channel Grant, then the MS shall do nothing, otherwise the MS shall leave the payload channel without making any further transmissions.
- b) For a call to a talkgroup, if the target address transmitted by the P\_PROTECT(ILLEGALLY\_PARKED) PDUs matches the target address transmitted by the Channel Grant, then the MS shall do nothing, otherwise the MS shall leave the payload channel without making any further transmissions.
- c) If an individual call has been set up and the two parties are active on the traffic channel, the P\_PROTECT(ILLEGALLY\_PARKED) is an appropriate PDU for the TS to send in the gaps between items. However if an include call is initiated by one of the MSs addressed to a third party, there will be three parties engaged in the call. From this point, between items, and until the call is cleared down:
  - the P\_PROTECT(ILLEGALLY\_PARKED) shall not be sent by the TS;

- the TS may send LC Terminator PDUs.

#### 6.6.2.4.1.6 Clearing down the voice call

The TS shall clear the parties involved in the payload voice call if:

- a) The relevant overall payload call timer T\_MS-MS\_TIMER, T\_MS-Line\_TIMER or T\_EMERG\_TIMER expires.
- b) The TS receives a P\_MAINT (Maint\_Kind = DISCON) PDU.
- c) The TS detects by any other means that the call has ended (e.g. PSTN destination on hook).
- d) The TV\_Hangtime interval timer expires.

The TS shall clear down the call by transmitting P\_CLEAR PDU(s). Since this PDU is not acknowledged it may be repeated at layer 2.

#### 6.6.2.4.1.7 TS single part voice call termination MSC

Figure 6.43 illustrates the MSC showing the TS voice call termination procedure for MS to MS or MS-Talkgroup call on payload channel as described in clause 6.6.2.3.1.6.

NOTE: The option 'TS detects by other means that the call has ended' is not illustrated in this MSC.

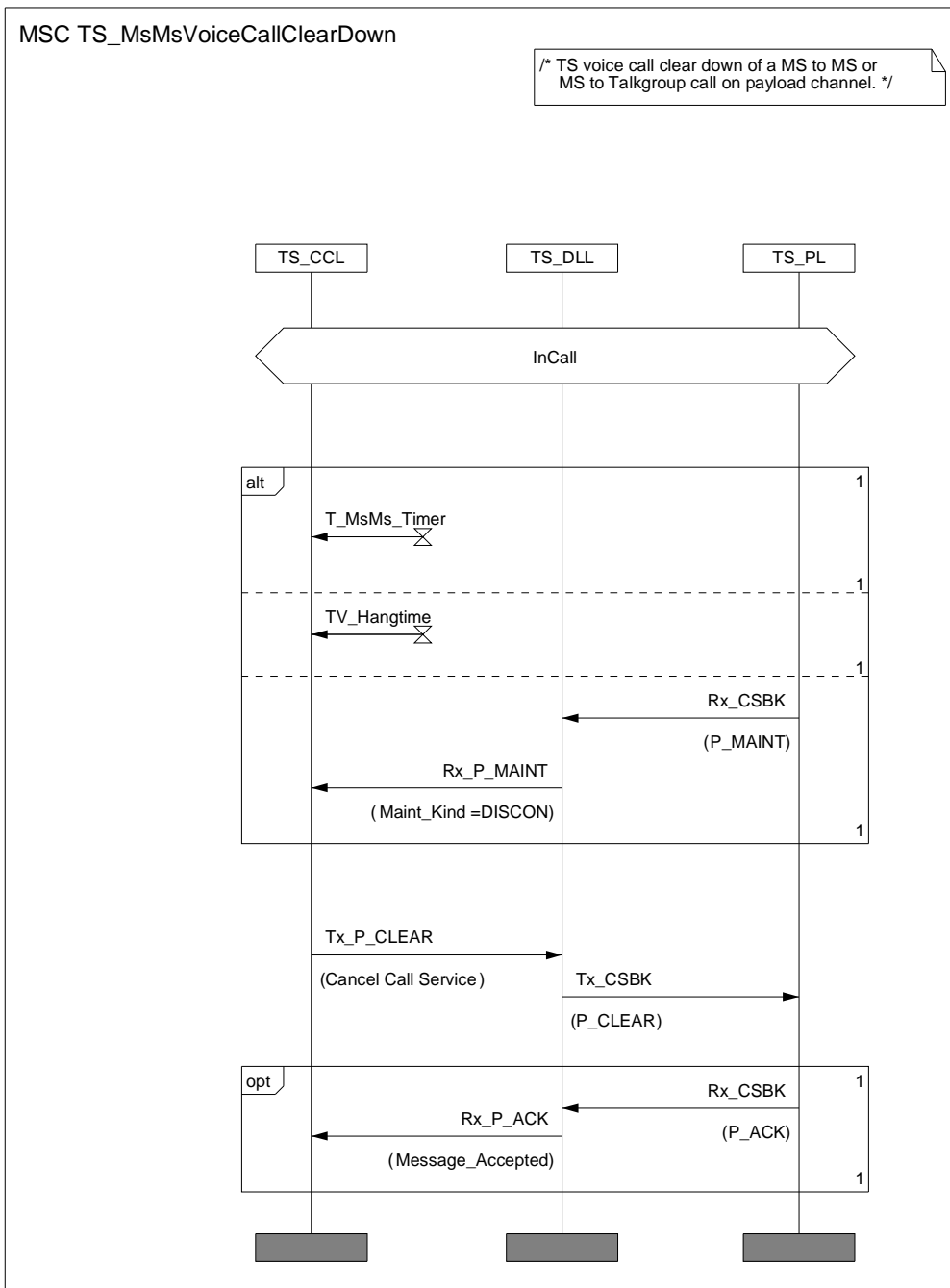

Figure 6.43: Voice Call Termination MSC

#### 6.6.2.4.1.8 Clearing down a particular MS or talkgroup

The TS may selectively clear an individual MS by transmitting a P\_AHOY with information elements set as table 6.36.

**Table 6.36: P\_AHOY information elements to clear an individual MS from a voice payload channel**

Service_Options_Mirror	7	000 0000 <sub>2</sub>
Service_Kind_Flag	1	0 <sub>2</sub> Indicates that the target is an Individual Address
Ambient Listening Service	1	0 <sub>2</sub> - Not Applicable
IG	1	0 <sub>2</sub> - The Target address is an MS individual ID
Appended_Blocks	2	00 <sub>2</sub>
Service_Kind	4	Cancel Call Service - 1111 <sub>2</sub> Service_Kind_Flag - 0 <sub>2</sub>
Target address	24	Individual Address of MS
Source Address or Gateway	24	TSI (see clause A.4)

The permitted response is P\_ACKU(Message\_Accepted).

The TS may clear a talkgroup by transmitting a P\_AHOY with information elements set as table 6.37.

**Table 6.37: P\_AHOY information elements to clear a talkgroup from a voice payload channel**

Service_Options_Mirror	7	000 0000 <sub>2</sub>
Service_Kind_Flag	1	1 <sub>2</sub> Indicates that the target is a talkgroup
Ambient Listening Service	1	0 <sub>2</sub> - Not Applicable
IG	1	1 <sub>2</sub> - The Target address is a talkgroup
Appended_Blocks	2	00 <sub>2</sub>
Service_Kind	4	Cancel Call Service - 1111 <sub>2</sub>
Target address	24	Talkgroup
Source Address or Gateway	24	TSI

The permitted response is P\_ACKU(Message\_Accepted).

### 6.6.2.4.2 MS Procedures for the Voice Payload Channel

#### 6.6.2.4.2.1 MS receives an MS radio check

If an MS receives a P\_AHOY to its individual address with information elements set as table 6.34, then it shall respond with a P\_ACKU (Reason=MS\_Accepted).

If an MS receives a P\_AHOY to the talkgroup address previously transmitted in the Channel Grant PDU that directed this MS to the payload channel (PDUs set as table 6.35), then it shall respond with a P\_ACKU (Reason=MS\_Accepted).

#### 6.6.2.4.2.2 MS receives an Authentication Check Challenge

The authentication procedures are identical to the authentication procedures described in clause 6.4.8.2 but with the authentication response C\_ACKU PDU replaced by a P\_ACKU PDU.

#### 6.6.2.4.2.3 Disabling/enabling a users PTT

If the MS receives a P\_PROTECT (Protect\_Kind=DIS\_PTT) addressed to its individual address, to its talkgroup address previously transmitted in the Channel Grant PDU directed it to the payload channel, or ALLMSID, the MS shall disable its PTT.

If the MS receives a P\_PROTECT (Protect\_Kind=EN\_PTT) addressed to its individual address, to its talkgroup address previously transmitted in the Channel Grant PDU, or ALLMSID, the MS shall re-enable its PTT unless this MS was the recipient of a broadcast call.

#### 6.6.2.4.2.4 MS receives a Channel Grant PDU(s)

If a MS receives an applicable Channel Grant addressed to its individual address or to its talkgroup address previously transmitted in the Channel Grant PDU directed it to the payload channel, then it shall return to the designated physical/logical channel. If the PTT was disabled prior to receiving the Channel Grant, the PTT shall be re-enabled unless this MS was the recipient of a broadcast call set-up or a call to All-Unit ID.

#### 6.6.2.4.2.5 End of call

The MS shall signify the end of the call by transmitting a number of P\_MAINT (Maint\_Kind=DISCON). The MS shall send the P\_MAINT PDUs consecutively then return to the control channel acquisition procedures (it is suggested that the TSCC sampled is the TSCC that transferred the call to the payload channel).

#### 6.6.2.4.2.6 MS receives P\_CLEAR

If a MS receives an applicable P\_CLEAR PDU then it shall move to the TSCC indicated by the Logical Physical Channel Number PDU.

#### 6.6.2.4.2.7 MS receives a selective clear P\_AHOY

If a MS receives an individually addressed P\_AHOY, Service\_Kind=1111<sub>2</sub>, Service\_Kind\_Flag=0<sub>2</sub> information element then it shall send a P\_ACKU (Reason=MS\_Accepted), abandon the payload channel and return to the control channel acquisition procedures (it is suggested that the TSCC initially sampled is the TSCC that transferred the call to the payload channel).

If a MS receives a P\_AHOY, Service\_Kind=1111<sub>2</sub>, Service\_Kind\_Flag=1<sub>2</sub> information element addressed to its talkgroup address previously transmitted in the Channel Grant PDU the talkgroup then it shall send a P\_ACKU (Reason=MS\_Accepted) abandon the payload channel and return to the control channel acquisition procedures (it is suggested that the TSCC initially sampled is the TSCC that transferred the call to the payload channel).

#### 6.6.2.4.2.8 MS receives a P\_PROTECT PDU(s)

If a MS receives a P\_PROTECT(ILLEGALLY\_PARKED) PDU, then:

- a) For an individual call, if the target address received from P\_PROTECT(ILLEGALLY\_PARKED) PDU matches the target address from the Channel Grant AND the source address transmitted by the P\_PROTECT(ILLEGALLY\_PARKED) PDU matches the source address transmitted by the Channel Grant, then the MS shall do nothing, otherwise the MS shall leave the payload channel without making any further transmissions.
- b) For a call to a talkgroup, if the target address received from P\_PROTECT(ILLEGALLY\_PARKED) PDU matches the target address transmitted from the Channel Grant, then the MS shall do nothing, otherwise the MS shall leave the payload channel without making any further transmissions.

#### 6.6.2.4.2.9 Time out on the Payload Channel

A MS shall maintain a number of timers while active on a voice payload channel.

- a) Inactivity timer:
  - A MS shall measure the length of time the MS is unable to detect adequate signal quality. If the MS fails to detect adequate signal quality for a continuous time TV\_Inactive, the MS shall assume that the call has ended and return to the control channel acquisition procedures without sending any call termination signalling (it is suggested that the TSCC sampled is the TSCC that transferred the call to the payload channel).
- b) Item Duration timer:
  - A MS shall maintain a maximum item duration timer. If the MS reaches the maximum item duration TV\_Item, the MS shall transmit a Terminator with LC, disable the PTT and wait until the user releases the PTT before re-enabling the PTT.



- c) An overall payload call timer:
- If the overall voice payload call timer T\_MS-MS\_TIMER, T\_MS-Line\_TIMER or T\_EMERG\_TIMER expires, the MS shall transmit a number (N\_Maint) of P\_MAINT PDUs consecutively then return to the control channel acquisition procedures (it is suggested that the TSCC sampled is the TSCC that transferred the call to the payload channel) If the MS was sending speech frames when the overall voice payload call timer expires, the MS shall transmit a Terminator with LC prior to transmitting the P\_MAINT PDUs.

### 6.6.3 Packet Data Call Procedures

Packet data calls require a payload channel over which the call is conducted. Calls may be transacted between the entities in table 6.38.

**Table 6.38: Packet Data Call Services**

Mode	Originator	Recipient
Packet Data	MS	MS or Talkgroup
	MS	All MS (Broadcast)
	MS	Line Connected destination through a Gateway: IP Gateway Data Gateway Other gateway equipped for data
	Line Connected source via a Gateway: IP Gateway Data Gateway Other gateway equipped for data	MS or Talkgroup or All MS

A packet data payload channel may support multiple simultaneous calls.

#### 6.6.3.1 Packet Data Call Procedures for the TSCC

A MS requests a Tier III service by generating a random access request PDU with the Target Address set to:

- a) An individual MS address (single-part call setup).
- b) A talkgroup MS address (single-part call setup).
- c) A gateway address that indicates a multi-part call setup.

When the TSCC responds to the random access request, it shall start a timer (TP\_Timer). This timer shall be refreshed if the TSCC sends further call progress PDUs to the calling party.

##### 6.6.3.1.1 TSCC Response to single-part packet call set-up

When a random access packet data PDU is received on the TSCC, the TSCC shall send a response in accordance with the random access procedures prescribed in clause 6.2.

The PDUs that represent a valid response to the packet call single-part service random access request are:

- a) An acknowledgement PDU C\_NACKD, C\_QACKD, C\_WACKD.
- b) A UDT Head + appended block(s) (packet data call is diverted) UDT Header PDUs  
Source\_Address=DIVERTI (conveying a diverted address) Supplementary Flag = 1<sub>2</sub> and  
UDT\_Response = 0<sub>2</sub>.
- c) A C\_AHOY PDU (called party radio check).
- d) A C\_AHOY PDU, Source Address=Authentication Challenge Value (MS authentication check).
- e) A C\_AHOY PDU from SUPLI to upload supplementary data from calling MS.
- f) A Channel Grant PDU(s) for this call.

The order in which c) d) and e) shall be sent is prescribed in clause 6.4.13.

NOTE: A multi-block UDT cannot transfer all Service Options to the called party. If the Service Options are essential to the operation of the system, a C\_AHOY/response and a Multi\_block UDT/response may be sent to the MS.

#### 6.6.3.1.2 TSCC Response to multi-part packet call setup

For calls to extended\_addresses, the MS requests multi-part addressing by generating a packet data call random access request with the Destination Address information element set to a gateway address (PABXI, PSTNI, IPI etc.) and the Proxy Flag information element to indicate the number of digits for the extended\_address. For the number of dialled digits = 1 to 20 the Proxy Flag information element shall be set to 0<sub>2</sub>. For the number of dialled digits = 21 to 44 the Proxy Flag information element shall be set to 1<sub>2</sub>. The PDUs that shall represent a valid response to the voice call multi-part part voice service random access request are:

- a) An acknowledgement PDU C\_NACKD, C\_WACKD(reason=Wait).
- b) A C\_AHOY PDU from PABXI, PSTNI, LINEI, DISPATI for the calling MS to send the extended\_address information.
- c) A C\_AHOY PDU from SUPLI for the calling MS to send supplementary data (see clause 6.5).

For b) the TSCC shall then invoke the UDT procedure by sending a C\_AHOY to the calling MS to send the extended\_address information. For a call to the PABX or PSTN the extended\_address information shall be BCD digits. The Proxy Flag information element in the C-AHOY PDU shall be copied from the Proxy Flag information element received from the MS C\_RAND PDU.

For c) the TSCC shall then invoke the UDT procedure by sending a C\_AHOY to the calling MS to send the supplementary data. The format of the supplementary data is specified in the UDT.

If the TSCC does not successfully receive the UDT from the MS, the TSCC may repeat the C\_AHOY or transmit a C\_NACKD to indicate failure of the call.

#### 6.6.3.1.3 Acknowledgements sent on the TSCC to the calling MS (packet)

The TSCC may send acknowledgement PDUs following the random access data packet service request to indicate the progress of the call, to terminate the call. If the TSCC sends a PDU to indicate the progress of a call it shall start a waiting timer TP\_Timer. (The calling party MS maintains a similar timer).

- a) Progress PDUs are:
  - 1) C\_WACKD: Intermediate acknowledgement. More PDUs to follow.
  - 2) C\_QACKD: Called MS engaged in another call.
  - 3) C\_QACKD: Call is queued because the resource is in use at the moment.
- b) Termination PDUs are selected from an appropriate Reason information element in a C\_NACKD PDU (see clause 7.2.8):
  - 1) C\_NACKD.
- c) If the TS has previously accepted a call diversion indicating that this type of service request be directed to another called party, the TSCC shall invoke the UDT and send a UDT Head + Appended data to the calling party.

#### 6.6.3.1.4 Radio Check for packet

For calls to individual MS, the TSCC shall check that the called party is in radio contact and shall accept the call before a payload channel is allocated. The radio check may also indicate that the called party data terminal equipment is ready.

The TSCC may check availability of the called party by:

- a) Sending a C\_AHOY PDU to that called party.

b) Sending a Multi-block UDT with supplementary data (if the supplementary data service is active for this call).

If a response is not received from the calling party the TSCC may repeat the C\_AHOY.

The availability check demands a response from the called party:

- If the response is C\_NACKU, the TSCC shall send an appropriate call failed response to the calling MS and echo the Reason in the C\_NACKD PDU.
- If the response is C\_ACKU(Reason=Message\_Accepted), the TSCC shall progress the service request and allocate a payload channel by transmitting appropriate Channel Grant PDUs.

For calls to packet talkgroups the TSCC may check that at least one member of the talkgroup is listening to the TSCC by sending a C\_AHOY addressed to the talkgroup.

### 6.6.3.1.5 Availability Check for Packet Calls connected through Gateways

For calls connected through gateways the TS equipment may wait until the destination is ready before allocating the payload channel. For example a TS waits until PSTN equipment has linked the data terminal before sending Channel Grant PDUs.

### 6.6.3.2 Packet Data Call Procedures for MS

A MS is able to request a packet data call service to another individual MS or a talkgroup using a single-part service request. For a packet data service requested to extended\_addresses through a gateway the MS requests a multi-part service request. For multi-part service requests the MS sets the gateway address as the called party. The full destination address is then provided by the MS to the TSCC by the UDT procedure.

A MS requests a packet data service by sending a C\_RAND random access request complying with the random access procedures in clause 6.2. The information elements in the random access request are passed to the CC layer - set appropriately as prescribed in table 6.39.

**Table 6.39: C\_RAND information elements for a Packet Data Call Service**

Information Element (I.E)	I.E Length	length	Alias	Value	Remark
Service_Options	7	1	EMERG	0 <sub>2</sub>	Non-emergency service
				1 <sub>2</sub>	Emergency service
		1	SUPED_SV	0 <sub>2</sub>	Privacy (see note 1)
				1 <sub>2</sub>	No Supplementary Data Transfer Service required for this call
		1	HI_RATE	0 <sub>2</sub>	Supplementary Data Transfer Service requested for this call
				1 <sub>2</sub>	MS requests single slot payload channel data timing
		1	OVCM_SV	0 <sub>2</sub>	MS requests dual slot payload channel data timing
				1 <sub>2</sub>	Non-OVCM call
		2	PRIORITY_SV (see note 2)	00 <sub>2</sub>	OVCM call
				01 <sub>2</sub>	Normal (low) priority
				10 <sub>2</sub>	Medium Priority
				11 <sub>2</sub>	High Priority
Proxy Flag	1	PROXY	0 <sub>2</sub>	Highest Priority	
			1 <sub>2</sub>	Number of Extended BCD digits for addressing through a PSTN/PABX gateway = 1 to 20. For IP gateway extended_address is IPV4	
				1 <sub>2</sub>	Number of Extended BCD digits for addressing through a PSTN/PABX gateway = 21 to 44. For IP gateway extended_address is IPV6

Information Element (I.E)	I.E Length	length	Alias	Value	Remark
Appended_Supplementary_Data	2		SUPED_VAL	Value	Number of appended UDTs required to transport supplementary data
Appended_Short Data	2		SDATA_VAL	00 <sub>2</sub>	Not Applicable for Packet Data
Service_Kind	4		IND_D_SRV	0010 <sub>2</sub>	Individual packet data Call Service
			GRP_D_SRV	0011 <sub>2</sub>	Talkgroup packet data Call Service
Target_address or Gateway	24			Value	Target Address (see note 3)
Source_address	24			Value	Individual Address of the requesting MS
NOTE 1: Privacy is not defined in the present document.					
NOTE 2: If EMERG = 1 <sub>2</sub> then PRIORITY_SV is set to 00 <sub>2</sub> .					
NOTE 3: If Service_Kind = IND_D_SRV then Target_Address represents an Individual address. If Service_Kind = GRP_D_SRV then Target_Address represents a Talkgroup.					
NOTE 4: If SUPED_SV = 0 <sub>2</sub> then SUPED_VAL = 00 <sub>2</sub> .					

### 6.6.3.2.1 Initiating a single-part packet data call service

For a packet data service request to an individual MS or talkgroup, the destination address is completely expressed by the Target Address information element in the random access PDU. The Service\_Kind specifies if the data packet call service is addressed to an individual address or a talkgroup.

### 6.6.3.2.2 Response to the single-part packet service request

MS shall accept the following PDUs as valid response to the single-part data packet service request:

- a) an acknowledgement C\_WACKD, C\_QACKD, C\_NACKD;
- b) a C\_AHOY from the calling party MS ID - called party radio check;
- c) a Channel Grant PDU;
- d) if the Service\_Options SUPED\_SV = 1<sub>2</sub> a C\_AHOY from SUPLI to upload the supplementary data from the calling MS;
- e) a UDT Head + appended blocks UDT Header PDUs Source\_Address=DIVERTI, Embedded\_Flag = 1.

### 6.6.3.2.3 Response to the multi-part packet data service request

MS shall accept the following PDUs as valid response to the multi-part data packet service request:

- a) an acknowledgement C\_WACKD, C\_QACKD, C\_NACKD;
- b) a C\_AHOY PDU from PABXI,PSTNI,LINEL,DISPATI to upload the extended\_address:
  - 1) for a call to the PABX/PSTN/LINEL,DISPATI, a C\_AHOY to upload the dialled digits;
  - 2) if the Service\_Options SUPED\_SV = 1<sub>2</sub> a C\_AHOY from SUPLI to upload the supplementary data from the calling MS.

NOTE: For b), if the Data packet Call Service Request requires extended\_address information and the calling MS has selected the Supplementary Data in the Service option, the TSCC uploads the information in two steps. The order in which the information is uploaded is not prescribed because the C\_AHOY specifically indicates which UDT inbound procedure has been invoked by setting appropriate unambiguous information elements in the C\_AHOY PDU.

#### 6.6.3.2.4 Acknowledgements received by the calling MS (packet data)

At some time after sending the packet data service request random access PDU the calling MS may receive an acknowledgement. On receiving the acknowledgement, the MS shall start or restart a waiting timer, TP\_Timer. (The TSCC maintains a similar timer.)

The MS shall take the actions prescribed:

- a) Progress PDUs for a single-part data packet call Service Request are:
  - 1) C\_WACKD: Intermediate acknowledgement. More PDUs to follow. The MS shall wait TP\_Timer for further signalling and may indicate a possible delay to the calling MS;
  - 2) C\_QACKD (Reason=Queued\_for\_Busy): Called MS engaged in another call. The MS shall wait TP\_Timer for further signalling and may indicate a possible delay to the calling MS;
  - 3) C\_QACKD (Reason=Queued\_for\_Resource): Call is queued because the resource is in use at the moment. The MS shall wait TP\_Timer for further signalling and may indicate a possible delay to the calling MS. The MS may choose to differentiate between 1), 2) and 3) by providing the calling MS with a particular indication for each of the conditions.
- b) Termination PDUs are selected from an appropriate Reason information element in a C\_NACKD PDU (see clause 7.2.8):
  - 1) C\_NACKD: Call refused and terminated. The C\_NACKD PDU provides a versatile range of Reason codes to indicate to the calling party why the Service request was terminated. The calling party shall return to the idle state. If the call was rejected by the calling party, the termination PDU sent by the TS shall be a C\_NACKD(mirrored\_reason):

#### 6.6.3.2.5 Availability Check to the called MS (packet data)

For an individual MS address call set-up, the called MS shall receive a radio check to which it shall respond with an appropriate acknowledgement.

- The called party shall respond C\_NACKU, if it cannot accept the call or its data terminal equipment is not ready (the TSCC shall send an appropriate call failed response to the calling MS (mirrored\_reason)).
- The calling party shall respond C\_ACKU (Reason=Message\_Accepted), if the call is accepted (the TSCC shall progress the service request and allocate a payload channel by transmitting appropriate Channel Grant PDUs).

#### 6.6.3.2.6 Payload Channel Allocation

MS shall check the address information elements received in Packet Data Channel Grant PDUs. If it is determined that the Channel Grant PDU is applicable then it shall return to the indicated physical/logical payload channel to commence the Packet Data Service.

- a) For Private Packet Data Channel Grant CSBK PDU:
  - 1) If an MS receives a Private Channel Grant PDU where either the Source Address or the Target Address information element matches its individual address then that PDU is applicable.
- b) Talkgroup Packet Data Channel Grant CSBK PDU:
  - 1) If an MS receives a Talkgroup Channel Grant PDU with the Target Address information element matching one of its talkgroup addresses then that PDU is applicable.
  - 2) If an MS receives a Talkgroup Channel Grant PDU with the Source Address matching its individual address then that PDU is applicable.

### 6.6.3.3 Procedures for the Packet Data Payload Channel

MSs are directed to a Packet Data payload physical/logical channel on the TSCC. When the Packet Data call is terminated by either the TS or MS, the MS shall return to the TSCC. When a physical channel has been assigned, data PDUs of arbitrary length are transferred over the DMR Air Interface using the packet technique described in TS 102 361-1 [5] and TS 102 361-3 [7].

A Packet Data call may continue unless the call is terminated by a) the MS or b) the TS or c) terminated prematurely as a result of the expiry of an overall payload call payload timer).

A physical channel may be configured such that two independent payload channels are available to the system (single slot transmission mode) or a high-speed data mode (dual slot transmission mode) where both logical channels are combined to provide a high-speed Packet Data service. The particular data speed configuration is requested by the calling MS and signalled to the parties by the Channel Grant PDUs.

The procedures for TS/MS behaviour on the Packet Data payload channel are described in TS 102 361-3 [7]. In the trunked environment however, additional call maintenance PDUs are exchanged between MS and TS in addition to the PDUs described in TS 102 361-3 [7].

When active on a payload channel, the TS shall transmit the CACH in the same form as described in TS 102 361-2 [6], clause 7.1.3.2).

The system may direct a number of independent Packet Data calls to the same Packet Data channel. MSs may then share that channel, but it shall be noted that while MS are away from the TSCC, they are unable to receive new calls. New Packet Data calls directed to a MS that is active on a Packet Data channel may either be queued by the system or such a call may be directed to the Packet Data channel and share the channel with other ongoing calls.

If the destination is an ipv4 or ipv6 address, the destination address shall have been specified by the calling party as a function of a multi-part call set-up. Therefore when the MS is directed to the packet data payload channel the system will have the full destination address. The MS may therefore set the destination address to IPI for all packet data items.

If an MS receives a packet data call set-up from an ipv4 or ipv6 address, the UDT protocol is able to send the full calling party IP address as part of the call set-up using the supplementary data transfer service. The system may then use IPI as the source address for the packet data call.

#### 6.6.3.3.1 TS Procedures for the Packet Data Payload Channel

If a new physical channel is allocated on the TSCC, the CCL\_BS shall start both the CCL\_1 and CCL\_2 processes as described in TS 102 361-2 [6], clause 5.1.1.1.3) and start the Packet Data payload timer T\_PACKET\_TIMER.

##### 6.6.3.3.1.1 MS radio check

The TS may poll an individual MS to check if the MS is active on the payload channel by transmitting a P\_AHOY PDU with the information elements set as follows.

The TSCC transmits a P\_AHOY with the information elements as illustrated in table 6.40.

**Table 6.40: P\_AHOY information elements for Packet Data service individual radio check**

Service_Options_Mirror	7	000 0000 <sub>2</sub>
Service_Kind_Flag	1	0 <sub>2</sub>
Ambient Listening Service	1	0 <sub>2</sub> - Not Applicable
IG	1	0 <sub>2</sub> - The Target address is an MS individual ID
Appended_Blocks	2	00 <sub>2</sub>
Service_Kind	4	Individual Packet Call Service - 0010 <sub>2</sub>
Target address	24	Individual Address of Called MS
Source Address or Gateway	24	TSI

The response is C\_ACKU (Reason=Message\_Accepted).

The TS may also poll a talkgroup to check if at least one member of the talkgroup is active on the payload channel by transmitting a P\_AHOY PDU with the information elements set as follows.

The TSCC transmits a P\_AHOY with the information elements as illustrated in table 6.41.

**Table 6.41: P\_AHOY information elements for packet service talkgroup radio check**

Service_Options_Mirror	7	000 0000 <sub>2</sub>
Service_Kind_Flag	1	0 <sub>2</sub>
Ambient Listening Service	1	0 <sub>2</sub> - Not Applicable
IG	1	1 <sub>2</sub> - The Target address is a talkgroup
Appended_Blocks	2	00 <sub>2</sub>
Service_Kind	4	Talkgroup Packet Call Service - 0011 <sub>2</sub>
Target address	24	Address of the talkgroup
Source Address or Gateway	24	TSI

The response is P\_ACKU (Reason=Message\_Accepted). If more than one MS makes a response to this PDU, it is likely that the TS will be unable to decode it because of collisions. The purpose of this procedure is to determine if any talkgroups are active therefore the TS may use the presence of the burst for the result of the talkgroup radio check.

#### 6.6.3.3.1.2 Authentication Check

The authentication procedures are identical to the authentication procedures described in clause 6.4.8.2 but with the C\_AHOY PDU replaced by a P\_AHOY PDU.

#### 6.6.3.3.1.3 Disabling/enabling a users transmission

The TS may at any time send a P\_PROTECT (Protect\_Kind=DIS\_PTT) addressed to an individual MS, talkgroup, or All\_Unit ID15 (see TS 102 361-1 [5], annex A) to disable all MS transmissions for the remainder of the call. Since the P\_PROTECT PDU is unacknowledged the PDU may be repeated.

The TS may also at any time send a P\_PROTECT (Protect\_Kind=EN\_PTT) addressed to an individual MS, talkgroup, or All\_Unit ID15 (see TS 102 361-1 [5], annex A) to enable the users transmission. Since the P\_PROTECT PDU is unacknowledged the PDU may be repeated at layer 2.

#### 6.6.3.3.1.4 Swapping the call to a replacement Packet Data payload channel

The TS may send Channel Grant PDUs to move MS already active to an alternative packet data payload channel. If MS had previously received a P\_PROTECT to disable its transmissions, the transmissions shall be re-enabled on the replacement packet data payload channel. The replacement packet data channel shall be with the same slot configuration (single or dual slot). If the packet data payload channel supports multiple simultaneous calls then channel grant PDUs shall be transmitted for each of the MS or talkgroups currently active on the payload channel.

#### 6.6.3.3.1.5 Clearing down the packet data channel

The TS shall clear down the parties involved in all payload calls if:

- the relevant overall payload call timer T\_PACKET\_TIMER expires;
- the TS receives a P\_MAINT (Maint\_Kind = DISCON) PDU;
- the TS detects by any other means that the call has ended (e.g. PSTN destination on hook);
- the TV\_Hangtime interval timer expires.

The TS shall clear down the data call by transmitting P\_CLEAR PDU(s). Since this PDU is not acknowledged it may be repeated at layer 2.

### 6.6.3.3.1.6 Clearing down a particular MS or talkgroup

The TS is able to clear down the parties involved in a payload call if:

- a) the TS receives a P\_MAINT (Maint\_Kind = DISCON) PDU;
- b) the TS detects by any other means that the packet call has ended.

The TS response to an applicable P\_MAINT(Maint\_Kind-DISCON) is P\_NACKD.

The TS may selectively clear a MS by transmitting a P\_AHOY with information elements set as table 6.42.

**Table 6.42: P\_AHOY information elements to clear an individual MS from a packet payload channel**

Service_Options_Mirror	7	000 0000 <sub>2</sub>
Service_Kind_Flag	1	0 <sub>2</sub> Indicates that the target is an Individual Address
Ambient Listening Service	1	0 <sub>2</sub> - Not Applicable
IG	1	0 <sub>2</sub> - The Target address is an MS individual ID
Appended_Blocks	2	00 <sub>2</sub>
Service_Kind	4	Cancel Call Service - 1111 <sub>2</sub> Service_Kind_Flag - 0 <sub>2</sub>
Target address	24	Individual Address of MS
Source Address or Gateway	24	TSI

The permitted response is P\_ACKU (Message\_Accepted).

The TS may selectively clear a talkgroup by transmitting a P\_AHOY with information elements set as table 6.43.

**Table 6.43: P\_AHOY information elements to clear a talkgroup from a packet payload channel**

Service_Options_Mirror	7	000 0000 <sub>2</sub>
Service_Kind_Flag	1	1 <sub>2</sub> Indicates that the target is a talkgroup
Ambient Listening Service	1	0 <sub>2</sub> - Not Applicable
IG	1	1 <sub>2</sub> - The Target address is a talkgroup
Appended_Blocks	2	00 <sub>2</sub>
Service_Kind	4	Cancel Call Service - 1111 <sub>2</sub> Service_Kind_Flag - 0 <sub>2</sub>
Target address	24	talkgroup
Source Address or Gateway	24	TSI

The permitted response is P\_ACKU (Message\_Accepted).

### 6.6.3.3.2 MS Procedures for the Packet Data Payload Channel

#### 6.6.3.3.2.1 MS receives an MS radio check

If an MS receives a P\_AHOY to its individual address with information elements set as table 6.42, then it shall respond with a P\_ACKU (Reason=message\_accepted).

If an MS receives a P\_AHOY to it is the talkgroup address previously transmitted in the Channel Grant PDU that directed this MS to the payload channel (information elements set as table 6.43) then it shall respond with a P\_ACKU (Reason=message\_accepted).

#### 6.6.3.3.2.2 MS receives a Authentication Check Challenge

The authentication procedures are identical to the authentication procedures described in clause 6.4.8.2 but with the authentication response C\_ACKU PDU replaced by a P\_ACKU PDU.



#### 6.6.3.3.2.3 Disabling/enabling a user transmission

If the MS receives a P\_PROTECT (Protect\_Kind=DIS\_PTT) addressed to its individual address, or to its talkgroup address previously transmitted in the Channel Grant PDU, or All\_Unit ID15 (see TS 102 361-1 [5], annex A), the MS shall disable its transmissions.

If the MS receives a P\_PROTECT (Protect\_Kind=EN\_PTT) addressed to its individual address, to its talkgroup address previously transmitted in the Channel Grant PDU, or All\_Unit ID15 (see TS 102 361-1 [5], annex A), the MS shall re-enable its transmissions.

#### 6.6.3.3.2.4 MS receives a Channel Grant PDU(s)

If a MS receives an applicable Channel Grant addressed to its individual address or to its talkgroup address previously transmitted in the Channel Grant PDU, then it shall retune to the designated physical/logical channel. If the PTT was disabled prior to receiving the Channel Grant, the PTT shall be re-enabled unless this MS was the recipient of a broadcast call set-up or a call to All\_Unit ID.

#### 6.6.3.3.2.5 End of call

The MS shall signify the end of the call by transmitting a number of P\_MAINT (Maint\_Kind = DISCON). The MS shall send the P\_MAINT PDUs consecutively then return to the control channel acquisition procedures (it is suggested that the TSCC initially sampled is the TSCC that transferred the call to the payload channel).

#### 6.6.3.3.2.6 MS receives P\_CLEAR

If a MS receives an applicable P\_CLEAR PDU then it shall abandon the payload channel and move to the TSCC indicated by the Logical Physical Channel Number PDU.

#### 6.6.3.3.2.7 MS receives a selective clear P\_AHOY

If a MS receives an individually addressed P\_AHOY, Service\_Kind=1111<sub>2</sub>, Service\_Kind\_Flag=0<sub>2</sub> information element then it shall send a P\_ACKU (Reason=Message\_Accepted), abandon the payload channel and return to the control channel acquisition procedures (it is suggested that the TSCC initially sampled is the TSCC that transferred the call to the payload channel).

If a MS receives a P\_AHOY, Service\_Kind=1111<sub>2</sub>, Service\_Kind\_Flag=1<sub>2</sub> information element addressed to its talkgroup address previously transmitted in the Channel Grant PDU the talkgroup then it shall send a P\_ACKU (Reason=Message\_Accepted) abandon the payload channel and return to the control channel acquisition procedures (it is suggested that the TSCC initially sampled is the TSCC that transferred the call to the payload channel).

#### 6.6.3.3.2.8 Time out on the Payload Channel

A MS shall maintain a number of timers while active on a packet data payload channel.

##### a) Inactivity timer:

- A MS shall measure the length of time the MS is unable to detect adequate signal quality. If the MS fails to detect adequate signal quality for a continuous time TD\_Inactive, the MS shall assume that the call has ended and return to the control channel acquisition procedures without sending any call termination signalling (it is suggested that the TSCC sampled is the TSCC that transferred the call to the payload channel).

##### b) Item Duration timer:

- A MS shall maintain the maximum item duration timer TD\_Item. If the MS reaches the maximum item duration TD\_Item, the MS shall transmit a Terminator with LC, discontinue the item and indicate to the higher layers that the item was not successfully transmitted.

- c) An overall payload call timer:
- If the overall packet data payload call timer T\_PACKET\_TIMER expires, the MS shall transmit a number(N\_Maint) of P\_MAINT PDUs consecutively then return to the control channel acquisition procedures (it is suggested that the TSCC sampled is the TSCC that transferred the call to the payload channel) If the MS was sending speech frames when the overall data packet payload call timer expires, the MS shall transmit a Terminator with LC prior to transmitting the P\_MAINT PDUs.

## 6.6.4 Short Data Message Procedure

The Short Data Message service enables data to be transmitted between DMR entities using the control channel. Up to 368 bits of data may be transported using this service formatted in a number of formats including binary, BCD, 7 bit text, 8 bit characters, NMEA (IEC 61162-1 [8]), 16 bit UTF-16BE Unicode, IP, authentication and manufacturer specific proprietary formats. If variable length binary formatted data is being transported, the maximum number of bits is 367 because one bit is used to indicate the end of the applicable data (see B.3.1).

The Short Data Message procedure uses the multi-part call set-up. A MS may send a Short Data Message to an MS, a talkgroup, the PSTN or PABX, a line connected gateway, a dispatcher gateway, or one of the All MS identities ALLMSID, ALLMSIDL or ALLMSIDZ (if the TSCC permits it). The TSCC may also transmit a UDT short data message from a gateway addressed to an individual MS or talkgroup.

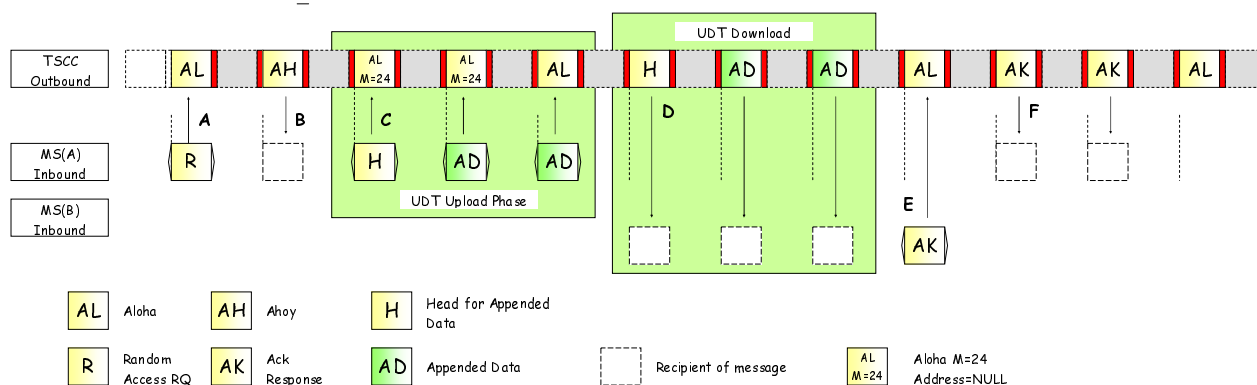

**Figure 6.44: Example of a Short Data Message transfer**

Figure 6.44 shows an example of a UDT short data message transfer from MS to MS:

- a) MS(A) calculates the number of appended UDTs needed to transmit the UDT short data. In this example, two appended UDTs are required;
- b) "A" is the random access C\_RAND PDU. The called party is MS(B) and Service\_Kind set to 'Short Data' and the Appended\_Short\_Data PDU to the number of data blocks needed to transport the UDT short data;
- c) "B" is a C\_AHOY PDU from SDMI that request MS(A) to transport the UDT short data using the UDT mechanism;
- d) "C" is the inbound phase consisting of a Multi-block UDT header + appended data;
- e) "D" is the outbound phase consisting of a Multi-block UDT header + appended data;
- f) "E" is the acknowledgement from MS(B);
- g) "F" is the final acknowledgement to the calling party MS(A). Note that the acknowledgement is repeated for reliability.

For a call to an extended\_address destination the TSCC uses the UDT mechanism to transport the extended\_address information. In this case the inbound phase shall use two UDT procedures. The PDUs in the C\_AHOY PDU indicate which UDT inbound transport is requested by unambiguous PDUs in the C\_AHOY PDU.

The maximum number of bits that may be transported by the UDT short data message service is limited by the maximum number of appended data UDTs. The Tier III protocol permits up to four appended UDTs.

For a UDT short data message service to a talkgroup, the called party shall not send a response. The TSCC may repeat the outbound phase to improve the probability of a successful message transfer. The TSCC shall send a final acknowledgement to the calling unit even though the receipt of the UDT short data message is not certain.

The timing for the inbound and outbound phases is not prescribed in the present document. Figure 6.45 shows examples of other applicable UDT short data message delivery.

In the first example, the UDT Header and appended UDTs are re-transmitted by the TSCC as soon as they have been received. This timing has the advantage of minimizing end-to-end latency (between two subscriber units); however, messages received with detectable but uncorrectable errors on the inbound phase result in messages containing uncorrectable errors on the outbound path which is essentially wasted bandwidth. The whole inbound and outbound phase would have to be repeated.

If the inbound phase is completed in its entirety as illustrated in the second example (and in figure 6.44), if uncorrectable errors are detected, that phase may be repeated before moving to the outbound phase. However, end-to-end latency (between the two MS) is sacrificed.

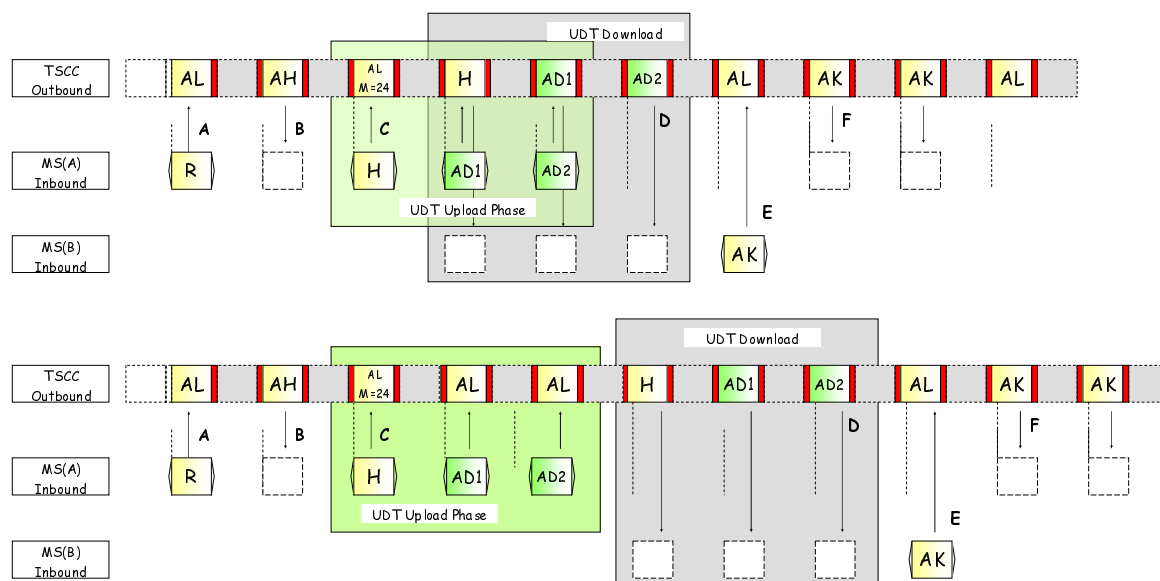

Figure 6.45: More Examples of a Short Data Message transfer

#### 6.6.4.1 Short Data Procedures for the TSCC

A MS requests a Tier III UDT short data message service by generating a random access request PDU with the Target Address set to:

- an individual MS address;
- a talkgroup MS address;
- a gateway address (a UDT to transport the extended destination address from the MS).

When the TSCC responds to the random access request, it shall start a timer (TNP\_Timer). This timer shall be refreshed if the TSCC sends further call progress messages to the calling party.

##### 6.6.4.1.1 TSCC Response to a call to an individual MS or talkgroup

When a random access short message service PDU is received on the TSCC, the TSCC shall send a response in accordance with the random access procedures prescribed in clause 6.2.

The PDUs that represent a valid response to the UDT short data message service random access request to a MS or talkgroup are:

- an acknowledgement PDU C\_NACKD, C\_QACKD, C\_WACKD;

- b) a UDT Head + appended block(s) (UDT short data call is diverted);
- c) a C\_AHOY PDU, Source Address=Authentication Challenge Value (MS authentication check);
- d) a C\_AHOY PDU from SDMI instructing the calling MS to transport its UDT short data message using the UDT mechanism;
- e) a C\_AHOY PDU from SUPLI instructing the calling MS to transport supplementary data using the UDT mechanism;
- f) for a call to an extended\_address, A C\_AHOY PDU from PABXI,PSTNI,LINEI,DISPATI,IPI instructing the calling party to send its extended\_address (such as PSTN, PABX etc.) using the UDT mechanism.

The order in which c) d) and e) shall be sent is prescribed in clause 6.4.13.

#### 6.6.4.1.2 TSCC Response to a call to an extended\_address destination

When a random access short message service PDU is received on the TSCC, the TSCC shall send a response in accordance with the random access procedures prescribed in clause 6.2.

The PDUs that represent a valid response to the UDT short data message service random access request to an extended\_address are:

- a) an acknowledgement PDU C\_QACKD, C\_WACKD;
- b) a C\_AHOY PDU from SDMI instructing the calling MS to transport its UDT short data message using the UDT mechanism;
- c) a C\_AHOY PDU from SUPLI instructing the calling MS to transport supplementary data using the UDT mechanism.

If b) is sent, b) shall follow a). (See clause 6.4.13).

The gateway PDUs for C\_AHOY PDUs to support UDT short data message services are prescribed in table 6.44.

**Table 6.44: C\_AHOY information elements for UDT short data message service to a gateway**

Action	Gateway Address	Remark
Send PSTN digits for the UDT short data destination	PSTNI	The calling party shall uplink BCD dialled digits
Send PABX digits for the UDT short data destination	PABXI	The calling party shall uplink BCD dialled digits
Send LINE digits for the UDT short data destination	LINEI	The calling party shall uplink BCD dialled digits
Send dispatcher digits for the UDT short data destination	DISPATI	The calling party shall uplink BCD dialled digits
Uplink IP address for the UDT short data destination	IPI	The calling party shall uplink the IPV4 or IPV6 address

- d) C\_NACKD: Call refused and terminated. The calling party shall return to the idle state. If the call termination was the result of the called party refusing the call, the C\_NACKD shall use a mirrored\_reason;
- e) if the TS has previously accepted a call diversion indicating that this type of service request be directed to another called party, a UDT Head + Appended data indicating the diverted address.

#### 6.6.4.1.3 Availability Check to the called MS (UDT short data)

For calls to individual MS, the TSCC may check that the called party is in radio contact before downloading the UDT short data.

The TSCC may check availability of the called party by:

- a) Sending a C\_AHOY PDU to that called party.
- b) Sending a Multi-block UDT with supplementary data (if the supplementary data service is active for this call).

If a response is not received from the calling party the TSCC may repeat the C\_AHOY.

The availability check demands a response from the called party:

- If the response is C\_NACKU, the TSCC shall abandon the short message call send an appropriate call failed response to the calling MS and echo the mirrored\_reason in the C\_NACKD PDU.
- If the response is C\_ACKU (Reason=Message\_Accepted), the TSCC shall progress the service request and download the UDT short data message using the UDT mechanism.

#### 6.6.4.1.4 Final acknowledgement to the calling party

In the outbound phase, the TSCC downloads the UDT short data message to the called party. If the recipient is an individual MS an acknowledgement shall be received on the TSCC. For a UDT short data message service to a talkgroup the outbound phase may be repeated but no acknowledgement shall be expected.

The TSCC shall send an appropriate acknowledgement to the calling party to indicate the outcome of the UDT short data transfer request. If the UDT download was received without errors the acknowledgement shall be C\_ACKU(Reason=MS\_Accepted). The mirrored C\_ACKD(Mirrored\_Reason=MS\_Accepted) shall then be sent to the calling MS.

#### 6.6.4.2 Short Data Message procedures for MS

A MS requests a UDT short data message call service to another individual MS or a talkgroup or gateway using a multi-part service request. For calls to an extended\_address, the transport of the extended\_address and the UDT short data message is uploaded by two separate UDT transfers.

A MS requests a UDT short data service by sending a C\_RAND random access request complying with the random access procedures in clause 6.2. The PDUs in the random access request are passed to the CC layer - set appropriately as prescribed in table 6.45.

**Table 6.45: C\_RAND information elements for a Short Data Message Service**

Information Element (I.E)	I.E Length	length	Alias	Value	Remark
Service_Options	7	1	EMERG	Not applicable - 0 <sub>2</sub>	
		1		0 <sub>2</sub>	Privacy (see note 1)
		1	SUPED_SV	0 <sub>2</sub>	No Supplementary Data Transfer Service required for this call
				1 <sub>2</sub>	Supplementary Data Transfer Service requested for this call
		1	BCAST_SV	0 <sub>2</sub>	Not applicable - 0 <sub>2</sub>
		1	OVCN_SV	0 <sub>2</sub>	Not applicable - 0 <sub>2</sub>
		2	PRIORITY_SV	00 <sub>2</sub>	Not applicable - 00 <sub>2</sub>
Proxy Flag	1		PROXY	0 <sub>2</sub>	Number of Extended BCD digits for addressing through a gateway = 1 to 20
				1 <sub>2</sub>	Number of Extended BCD digits for addressing through a gateway = 21 to 44
Appended_Supplementary_Data	2		SUPED_VAL	Value	Number of appended UDTs required to transport supplementary data. Note 3
Appended_Short Data	2		SDATA_VAL	Value	Number of appended UDTs required transport UDT short data
Service_Kind	4		IND_SD_SRV	0100 <sub>2</sub>	Individual Short Data Call Service
			GRP_SD_SRV	0101 <sub>2</sub>	Talkgroup Short Data Call Service
Target_address or Gateway	24			Value	Target Address (see note 2)
Source_address	24			Value	Individual Address of the requesting MS
NOTE 1: Privacy is not defined in the present document.					
NOTE 2: If Service_Kind = IND_SD_SRV then Target_Address represents an Individual address. If Service_Kind = GRP_SD_SRV then Target_Address represents a Talkgroup.					
NOTE 3: If SUPED_SV = 0 <sub>2</sub> then SUPED_VAL = 00 <sub>2</sub> .					

### 6.6.4.3 Initiating a Short Data Message service

For a UDT short data message service request to an individual MS or talkgroup, the destination address is completely expressed by the Target Address information element in the C\_RAND random access PDU. The Service\_Kind specifies if the Short Data Message call service is addressed to an individual address or a talkgroup. For calls to a gateway addresses the Target\_address or Gateway information element in the C\_RAND is set to the gateway address.

The MS shall attempt access until it receives a valid response, or the service is cancelled by the user, or the attempt fails by sending the maximum number of random access PDUs or the random access timer expires.

### 6.6.4.4 Response to a random access UDT short data message

The calling MS shall accept the following PDUs a valid response to the SDM random access request:

- a) an acknowledgement PDU C\_NACKD, C\_QACKD, C\_WACKD;
- b) a UDT Head + appended block(s) (UDT short data call is diverted);
- c) a C\_AHOY PDU from SDMI instructing the calling MS to transport its UDT short data message using the UDT mechanism;
- d) a C\_AHOY PDU from SUPLI instructing the calling MS to transport supplementary data using the UDT mechanism;
- e) for a call to an extended\_address, A C\_AHOY PDU from PABXI,PSTNI,LINEI,DISPATI,IPI instructing the calling party to send its extended\_address using the UDT mechanism.

If the particular PDU is sent, the order shall be a), d), e), f), c).

### 6.6.4.5 Acknowledgements received by the calling MS

When the C\_RAND PDU has been transmitted by the calling party, an initial response may be received by the calling party as specified in clause 6.6.4.4.

At any time further PDUs may be sent to the calling party as follows:

- a) a C\_NACKD at any time to indicate the call has failed. The Reason information element shall be set to indicate the reason for the call failure;
- b) a C\_WACKD if more signalling will follow;
- c) after the UDT short data message has been successfully transported, C\_ACKD PDU(Mirrored\_Reason=MS\_Accepted).

If a C\_NACKD is received, the calling MS shall abandon the UDT short data message call and return to the idle state.

Any applicable call progress acknowledgement received shall restart the TNP\_timer.

For c):

- 1) if the UDT short data is addressed to an individual MS then the acknowledgment reason shall be C\_ACKD(Mirrored\_Reason=MS\_Accepted);
- 2) if the UDT short data is addressed to a talkgroup the acknowledgment shall be ACK(Message\_Accepted). In this case it would not be known if any or all of the talkgroups received the UDT short data, only that the network sent the data to the talkgroup;
- 3) if the UDT short data is addressed to a gateway (for instance a line dispatcher) the acknowledgment shall be C\_ACKD(Mirrored\_Reason=Message\_Accepted).

### 6.6.4.6 Timeout waiting for further signalling

A MS waiting for further signalling shall abandon the UDT short data message service and return to the idle state if the TNP\_Timer expires.

### 6.6.4.7 MS receiving a UDT short data message

If a MS receives a multi block UDT Head PDU with the Target Address matching its individual address, it shall respond with an appropriate acknowledgement. The Appended\_Blocks information element in the UDT header indicates the number of appended UDT blocks.

If a MS receives a multi block UDT Head PDU with the Target Address matching a talkgroup, it shall accept the information contained in the appended blocks, but shall transmit no response.

### 6.6.4.8 Short Data Message procedure MSC

Figure 6.46 illustrates the Short Data Message procedure to an individual MS or Talkgroup as defined in clause 6.6.4.

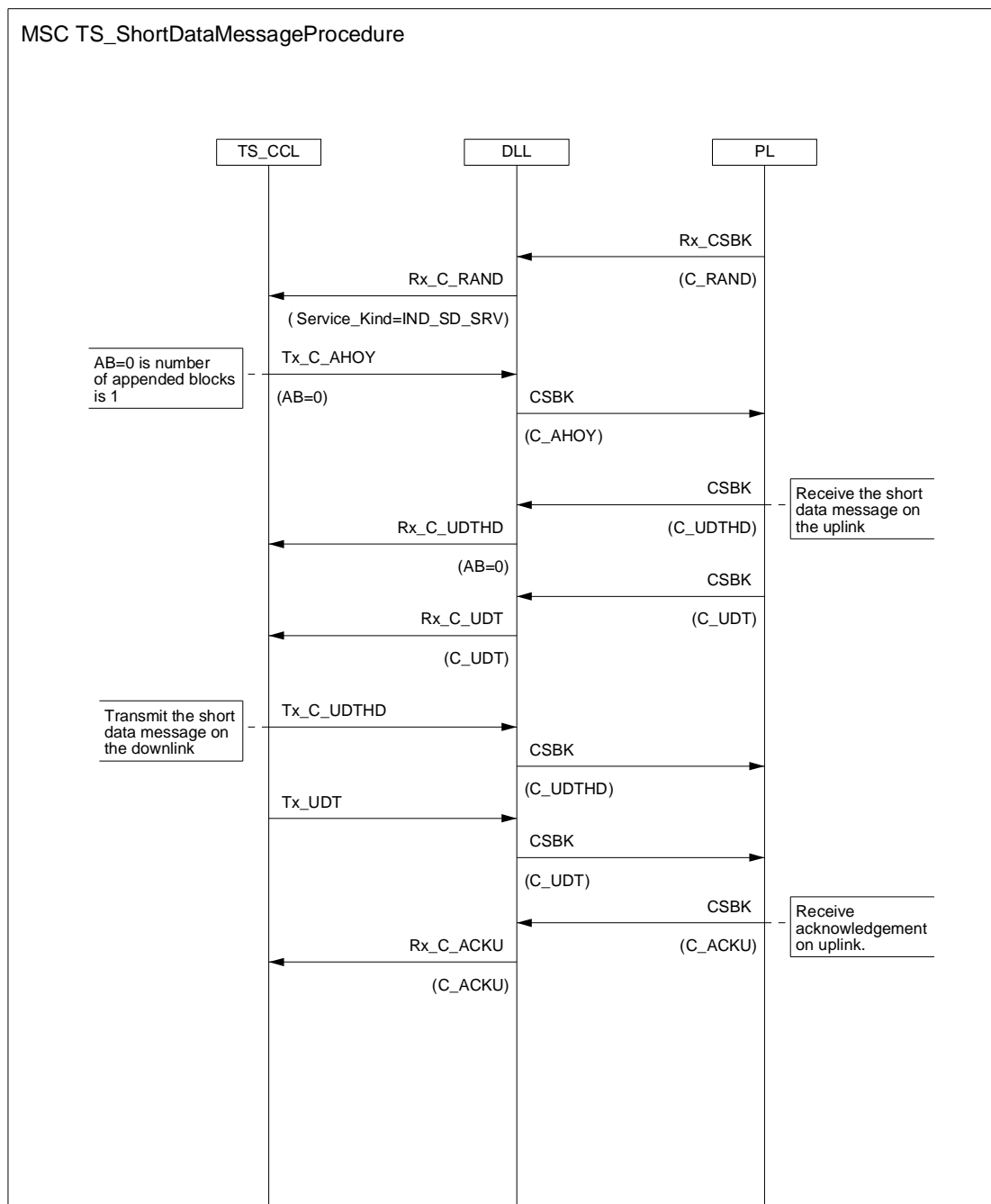

Figure 6.46: Short Data Message MSC

## 6.6.5 Short Data Polling Service

The Short Data Polling Message service enables data to be polled from MS using the control channel. Up to 368 bits of data may be transported using this service formatted in a number of formats including binary, BCD, ISO 7 bit text (ISO/IEC 646 [11]), ISO 8 bit characters (ISO/IEC 8859 [12]), NMEA (IEC 61162-1 [8]) formatted location data, and manufacturer specific proprietary formats. If variable length binary formatted data is being polled, the maximum number of bits is 367 because one bit is used to indicate the end of the applicable data (see clause B.3.1).

NOTE: Calling and polled MSs will pre-arrange the number of appended UDTs required to transport the polled data.

The Short Data Message polling procedure uses the single-part call set-up.

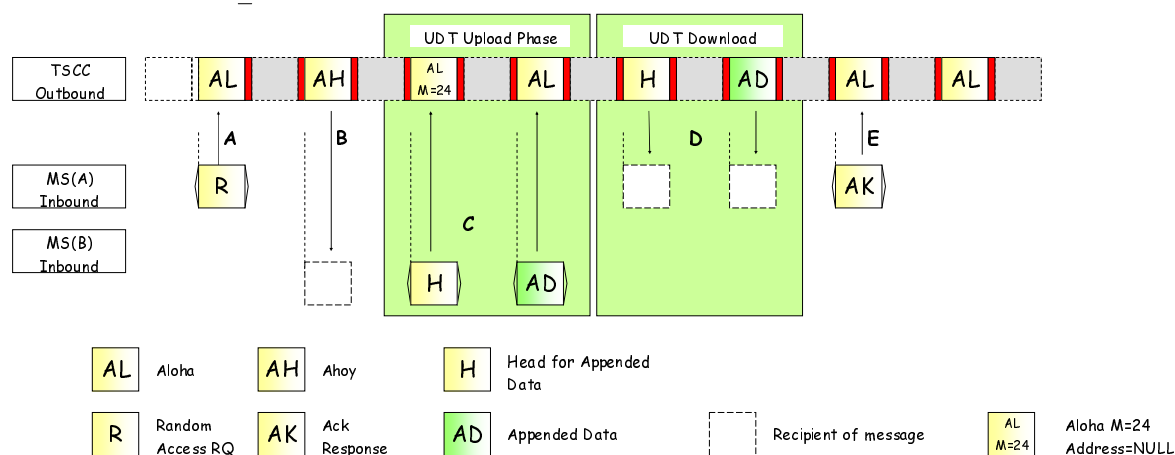

**Figure 6.47: Example of a Short Data Polling transfer**

Figure 6.47 shows an example of a UDT short data polling service:

- MS(A) specifies the number of appended UDTs for the polled UDT short data. In this example, one appended UDT is required;
- "A" is the random access C\_RAND PDU. The target address is set to the polled party, Service\_Kind set to 'Short Data Polling' and the Appended\_Short\_Data information element to the number of data blocks to transport the polled UDT short data;
- "B" is a C\_AHOY PDU from SDMI that requests MS(B) to transport the UDT short data using the UDT mechanism;
- "C" is the inbound phase consisting of a Multi-block UDT header + appended data;
- "D" is the outbound phase consisting of a Multi-block UDT header + appended data;
- "E" is the final acknowledgement from MS(A).

The maximum number of bits that may be transported by the UDT short data message polling service is limited by the maximum number of appended data UDTs. The Tier III protocol permits up to four appended UDTs.



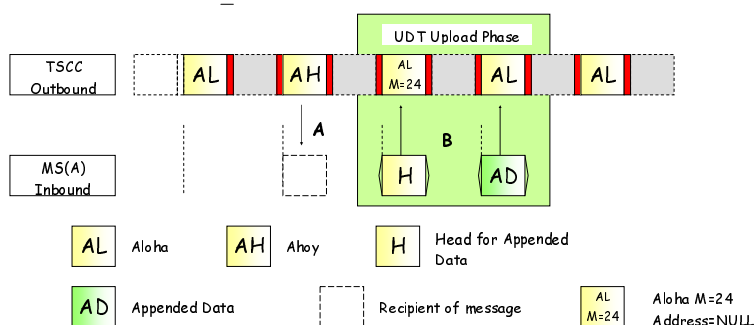

**Figure 6.48: Example of UDT short data polling from a gateway**

Figure 6.48 shows a UDT short data polling transfer from a gateway to a MS. The TSCC requests the UDT short data by transmitting a C\_AHOY PDU from SDMI addressed to MS(A). MS(A) responds with the UDT head + UDT short data.

### 6.6.5.1 Short Data Polling Procedures for the TSCC

A MS requests a Tier III UDT short data polling message service by generating a random access request PDU with the Target Address set to an individual address.

When the TSCC responds to the random access request, it shall start a timer (TNP\_Timer). This timer shall be refreshed if the TSCC sends further call progress PDUs to the calling party.

#### 6.6.5.1.1 TSCC Response to a poll request from an MS

When a random access UDT short data poll service PDU is received on the TSCC, the TSCC shall send a response in accordance with the random access procedures prescribed in clause 6.2.

The PDUs that represent a valid response to the UDT short data polling service random access request to a MS are:

- an acknowledgement PDU C\_NACKD, C\_QACKD, C\_WACKD;
- a C\_AHOY PDU from SDMI instructing the polled MS to transport supplementary data using the UDT mechanism;
- A C\_AHOY PDU from AUTHI (MS authentication check).

If the polled MS has diverted its calls the response shall be C\_NACKD (Reason= Div\_Cause\_Fail).

#### 6.6.5.1.2 Availability Check to the called MS (UDT short data poll)

The TSCC may check that the called party is in radio contact before polling the MS for the UDT short data.

The TSCC may check availability of the polled party by sending a C\_AHOY PDU addressed to the polled MS individual address. If a response is not received from the calling party the TSCC may repeat the C\_AHOY at layer 2. The availability check PDU Information Elements shall be as specified in clause 6.4.12 table 6.24.

The availability check demands a response from the called party:

- If the response is C\_NACKU, the TSCC shall abandon the short message polling transaction, send an appropriate call failed response to the calling MS and echo the Reason in the C\_NACKD PDU (mirrored\_reason).
- If the response is C\_ACKU (Reason=MS\_Accepted), the TSCC shall progress the service request and poll the MS for the UDT short data using the UDT mechanism.

#### 6.6.5.1.3 Delivery of the polled data to the calling party

In the outbound phase, the TSCC downloads the UDT short data polled message to the calling party using the UDT mechanism.

The calling MS shall send an appropriate acknowledgement to the TSCC to indicate the outcome of the UDT short data polling request.

#### 6.6.5.1.4 Final acknowledgement by the calling party to the TSCC

The final phase of the polling transaction is the acknowledgement from the calling MS that the polled data was successfully received. If the TSCC does not receive a response, it may repeat the outbound phase described in clause 6.6.5.1.3.

#### 6.6.5.1.5 Short Data Polling procedures from a TSCC gateway

The short polling service initiated through a gateway is illustrated in figure 6.48. The TSCC transmits a C\_AHOY PDU from SDMI addressed to an individual MS. The C\_AHOY PDU demands a response:

- a) If the response is C\_NACKU, the TSCC shall abandon the short message polling transaction.
- b) If the response is a multi-block UDT containing the polled data, the transaction is complete.

#### 6.6.5.2 Short Data Polling Message procedures for MS

A MS requests a UDT short data polling call service to another individual MS, using a single-part service request.

A MS requests a UDT short data polling service by sending a C\_RAND random access request complying with the random access procedures in clause 6.2. The information elements in the random access request are passed to the CC layer - set appropriately as prescribed in table 6.46.

**Table 6.46: C\_RAND information elements for a Short Data Polling Service**

Information Element (I.E)	I.E Length	length	Alias	Value	Remark
Service_Options	7	1	EMERG	Not applicable - 0 <sub>2</sub>	
		1		0 <sub>2</sub>	Privacy (see note)
		1	SUPED_SV	0 <sub>2</sub>	Not applicable - 0 <sub>2</sub>
		4	POL_FMT	Value	Format of the polled data
Proxy Flag	1		PROXY	0 <sub>2</sub>	Not Defined for the polling service
Reserved	2			00 <sub>2</sub>	
Appended_Short_Data	2		SDATA_VAL	00 <sub>2</sub>	Number of UDTs required to transport the polled UDT short data
Service_Kind	4		SD_P_SRV	0110 <sub>2</sub>	Short Data Polling Service
Target_address	24			Value	Polled individual MS address
Source_address	24			Value	Individual Address of the requesting MS
NOTE: Privacy is not defined in the present document.					

#### 6.6.5.3 Initiating a Short Data Polling service

For a UDT short data polling service request to an individual MS, the polling MS address is completely expressed by the Target Address information element in the C\_RAND random access PDU. The Service\_Kind specifies the Short Data Message call service.

The MS shall attempt access until it receives a valid response, or the service is cancelled by the user, or the attempt fails by sending the maximum number of random access PDUs or the random access timer expires.

#### 6.6.5.4 Response to a random access UDT short data polling message

The calling MS shall accept the following PDUs a valid response to the SDM random access request:

- a) An acknowledgement PDU C\_NACKD, C\_QACKD, C\_WACKD.
- b) A C\_AHOY PDU instructing the polled MS to transport its UDT short data message using the UDT mechanism.

For b):

- 1) For a poll from a gateway, the calling party address is SDMI.
- 2) For a poll originated from a MS, the calling party address is the MS individual address.

### 6.6.5.5 Final Acknowledgement transmitted by the calling MS

In the outbound phase, the TSCC downloads the UDT short data polled message to the calling party. Valid responses to the TSCC are:

- a) An acknowledgement PDU C\_NACKU indicating the transaction has failed.
- b) An acknowledgement PDU C\_ACKU(Reason=MS\_Accepted) indicating the transaction was successful.

### 6.6.5.6 Timeout waiting for further signalling

A MS waiting for further signalling shall abandon the UDT short data polling service and return to the idle state if the TNP\_Timer expires.

### 6.6.5.7 MS receiving a C\_AHOY poll for a short polling message

If a MS receives a C\_AHOY PDU with the Target Address matching its individual address and the Service\_Kind = Short Data Polling Service it shall respond with:

- a) A multi block UDT Head PDU with the Target Address matching its calling party (source) address from the C\_AHOY PDU. The Appended\_Blocks information element in the UDT header indicates the number of appended UDT blocks.
- b) A C\_NACKU PDU if the polled MS does not wish to accept the polling request.

## 6.6.6 Status Call Service

The Status Message service enables data to be transmitted between DMR entities on the control channel. Seven bits of data may be transported using this service. The status delivery service transports a status message from the initiator to a recipient. The status polling service enables an initiator to request a status message from an addressed entity. Seven bits are transported representing 127 status messages. Status values 000 0000<sub>2</sub> to 111 1110<sub>2</sub> are used for the Status Delivery Service and have a user-defined meaning that is not described in the present document. Status value 111 1111<sub>2</sub> defines the Status Polling Service.

Status messages addressed from MS to the TSCC are system messages.

### 6.6.6.1 Status Service Delivery Procedure

The Status Message Delivery procedure employs a store and forward mechanism. An MS may send a Status Message to an individual MS, talkgroup, the PSTN or PABX, a line connected gateway, a dispatcher gateway or the TSCC. The TSCC may also transmit a UDT short data message from a gateway or special identifier addressed to an individual MS or talkgroup.

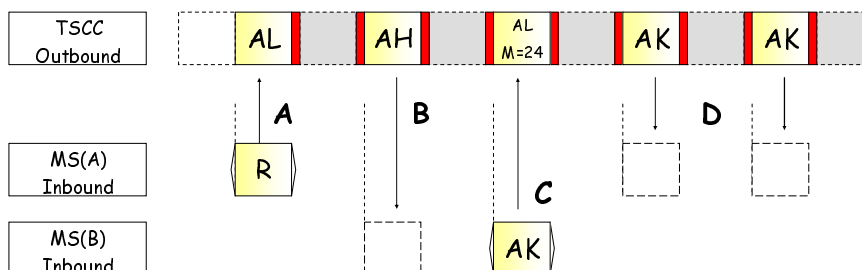

Figure 6.49: Example of the Status Delivery Service to an individual MS

Figure 6.49 shows an example of Status Message Delivery transfer from MS to an individual MS:

- a) "A" is the random access C\_RAND PDU. The called party is MS(B) and Service\_Kind set to 'Status'. The status value is in the range 000 0000<sub>2</sub> to 111 1110<sub>2</sub>;
- b) "B" is a C\_AHOY PDU from MS(A) that contains the Status value;
- c) "C" is the acknowledgement from MS(B);
- d) "D" is the final acknowledgement to the calling party MS(A). Note that the acknowledgement is repeated for reliability.

#### 6.6.6.1.1 Status Service Delivery Procedures for the TSCC

A MS initiates a Status Service Delivery by random access addressed to:

- a) An individual MS address (single-part call set-up);
- b) A gateway address that indicates a multi-part call set-up;
- c) The TSCC.

When the TSCC responds to the random access request it shall start timer (TNP\_Timer). This timer shall be refreshed if the TSCC sends further call progress messages to the calling party.

##### 6.6.6.1.1.1 TSCC Response to a single part Status Service Delivery call setup

On receipt of the random access service request the TSCC shall transmit either:

- a) An acknowledgement PDU C\_NACKD, C\_WACKD (Reason=Wait), C\_QACKD addressed to the calling MS;
- b) A C\_AHOY PDU addressed to the called party for this call to pass the status to the called MS;
- c) A C\_AHOY PDU from AUTHI (MS authentication check);
- d) A UDT Head \_ appended block(s) (status message service is diverted. If the TS has previously accepted a call diversion indicating that this type of service request be directed to another called party, the TSCC shall invoke the UDT and send a UDT Head + Appended data to the calling party.

##### 6.6.6.1.1.2 TSCC Response to a multi part Status Service Delivery call setup

For calls to extended\_addresses, the MS requests multi-part addressing by generating a status call random access request with the Destination Address information element set to a gateway address (PABXI, PSTNI, etc.) and the Proxy Flag information element to indicate the number of digits for the extended\_address. For the number of dialled digits = 1 to 20 the Proxy Flag information element shall be set to 0<sub>2</sub>. For the number of dialled digits = 21 to 44 the Proxy Flag information element shall be set to 1<sub>2</sub>. The PDUs that shall represent a valid response to the multi-part part Status service random access request are:

- a) An acknowledgement PDU C\_NACKD, C\_WACKD(reason=Wait);
- b) A C\_AHOY PDU from PABXI,PSTNI,LINEI,DISPATI,IPI for the calling MS to send the extended\_address information;
- c) A C\_AHOY PDU from SUPLI for the calling MS to send supplementary\_user data (see clause 6.4.13).

For b) The TSCC shall then invoke the UDT procedure by sending a C\_AHOY to the calling MS to send the extended\_address information. For a status call to the PABX or PSTN the extended\_address information shall be BCD digits. The Proxy Flag information element in the C-AHOY PDU shall be copied from the Proxy Flag information element received from the MS C\_RAND PDU. If the TSCC does not successfully receive the UDT from the MS, the TSCC may repeat the C\_AHOY, or transmit a C\_NACKD to indicate failure of the call.

For c) The TSCC shall then invoke the UDT procedure by sending a C\_AHOY to the calling MS to send the supplementary data. The format of the supplementary data is specified in the UDT. If the TSCC does not successfully receive the UDT from the MS, the TSCC may repeat the C\_AHOY, transmit a C\_NACKD to indicate failure of the call or continue with the call setup and abandon the supplementary data.

#### 6.6.6.1.1.3 Acknowledgements sent by the TSCC to the calling MS (status)

The TSCC may send acknowledgement PDUs following the random access Status Delivery Service request to indicate the progress of the call, or terminate the call. If the TSCC sends a PDU to indicate the progress of a call it shall start a waiting timer TNP\_Timer. (The calling party MS maintains a similar timer).

- a) Progress PDUs may be:
  - 1) C\_WACKD: Intermediate acknowledgement. More PDUs to follow;
  - 2) C\_QACKD: Called MS engaged in another call;
  - 3) C\_QACKD: Call is queued because the resource is in use at the moment.
- b) Termination PDUs are selected from an appropriate Reason information element in a C\_NACKD PDU (see clause 7.2.8):
  - 1) C\_NACKD.
- c) An acknowledgement PDU C\_ACKD indicating that the transaction was successful.

#### 6.6.6.1.1.4 Delivery of the status to the called party

The TSCC delivers the status to the called MS by transmitting a C\_AHOY PDU containing the Status information element. The status message may have originated from another MS, a gateway or the TSCC. For a status delivery service to an individual MS ID, the C\_AHOY PDU demands a response from the called MS. If the response is C\_ACKU(Reason=MS\_Accepted), the TSCC shall send an equivalent acknowledgement C\_ACKD(Mirrored\_Reason=MS\_Accepted) to the calling party. If the response is C\_NACKU, the mirrored C\_NACKD shall be sent to the calling party. If no response is received the TSCC may repeat the C\_AHOY or abandon the service and indicate the failure to the called party by transmitting a C\_NACKD. If the status delivery service is directed to a talkgroup, no acknowledgement shall be transmitted by the called talkgroup, nor is an acknowledgement expected by the TSCC. For reliability the C\_AHOY may be repeated.

For a status delivery to a talkgroup no response from the called party is expected but the TSCC shall send at least one C\_ACKD(Reason=Message\_Accepted) to the calling party to indicate that the transaction is completed. (See figure 6.50).

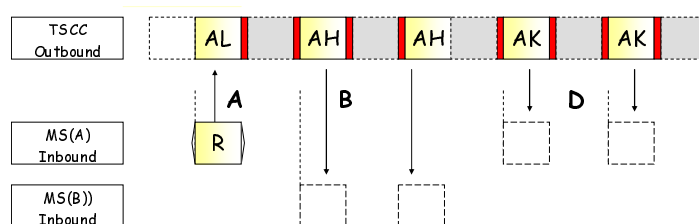

**Figure 6.50: Example of the Status Delivery Service to a talkgroup**

#### 6.6.6.1.1.5 Call Time Out

The TSCC shall maintain a timeout defining the maximum time it shall store a status message request waiting for the called MS or TSCC resource to become free.

#### 6.6.6.1.2 Status Service Delivery Procedures for MS

A MS requests a Status Message Delivery call service to another individual MS or a talkgroup using a single part service request or gateway using a multi-part service request. For calls to an extended\_address the sending of the extended\_address is by a UDT transfer.

A MS requests a Status Delivery Service by sending a C\_RAND random access request complying with the random access procedures in clause 6.2. The information elements in the random access request are passed to the CC layer - set appropriately as prescribed in table 6.47.

**Table 6.47: C\_RAND information elements for a Status Message Delivery Service**

Information Element (I.E)	I.E Length	length	Alias	Value	Remark
Service Options	1		IG	0 <sub>2</sub>	The target address is an MS individual ID
				1 <sub>2</sub>	The target address is a talkgroup
	1		SUPED_SV	0 <sub>2</sub>	No supplementary_user data transfer requested
				1 <sub>2</sub>	Supplementary_user data is requested for this call
	5		STATUS(5)	value	Most significant 5 bits of the STATUS (see note 4)
Proxy Flag	1		PROXY	0 <sub>2</sub>	Number of Extended BCD digits for addressing through a gateway = 1 to 20
				1 <sub>2</sub>	Number of Extended BCD digits for addressing through a gateway = 21 to 44
Appended_Supplementary_Data	2		SUPED_VAL	Value	Number of appended UDTs required to transport supplementary data
	2		STATUS(2)	value	Least significant 2 bits of the STATUS (see note 4)
Service_Kind	4		IND_ST_SRV	0111 <sub>2</sub>	Status Transport Service
Target_address or Gateway	24			Value	Target Address (see note 2)
Source_address	24			Value	Individual Address of the requesting MS
NOTE 1: Privacy is not defined in the present document.					
NOTE 2: Target_Address represents an Individual address or gateway, or a talkgroup if IG=1 <sub>2</sub> .					
NOTE 3: If SUPED_SV = 0 <sub>2</sub> then SUPED_VAL = 00 <sub>2</sub> .					
NOTE 4: STATUS is in the range 000 0000 <sub>2</sub> to 111 1110 <sub>2</sub> .					

#### 6.6.6.1.2.1 Status Message Delivery service to an individual MS or gateway

##### 6.6.6.1.2.1.1 Initiating the Status Message Delivery service to the MS or gateway

For a Status Message Delivery service request to an individual MS, the destination address is completely expressed by the Target Address information element in the C\_RAND random access PDU. IG=0<sub>2</sub>. The Service\_Kind specifies the Status Message call service. For calls to a gateway addresses the Target\_address or Gateway information element in the C\_RAND is set to the gateway address.

The MS shall attempt access until it receives a valid response, or the service is cancelled by the user, or the attempt fails by sending the maximum number of random access PDUs or the random access timer expires.

##### 6.6.6.1.2.1.2 Response to a random access Status Message Delivery service request

The calling MS shall accept the following PDUs a valid response to the status service random access request:

- a) An acknowledgement PDU C\_NACKD, C\_QACKD, C\_WACKD;
- b) A UDT Head + appended block(s) (status call is diverted);
- c) A C\_AHOY PDU to the called MS containing the status;
- d) A C\_AHOY PDU from AUTHI (MS authentication check);
- e) A C\_AHOY PDU instructing the calling MS to transport supplementary data using the UDT mechanism.
- f) For a call to an extended\_address, A C\_AHOY PDU from PABXI, PSTNI, LINEI, DISPATI, IPI instructing the calling party to send its extended\_address using the UDT mechanism.

NOTE: d), e) and f) may be performed in any order.

#### 6.6.6.1.2.1.3 Acknowledgements received by the calling MS

When the C\_RAND PDU has been transmitted by the calling party, an initial response may be received by the calling party as specified in clause 6.6.6.1.1.3.

At any time further PDUs may be sent to the calling party as follows:

- a) A C\_NACKD at any time to indicate the call has failed. The Reason information element shall be set to indicate the reason for the call failure. If the C\_NACKD sent to the calling MS is the result of a C\_NACK from the called MS, a mirrored\_reason code shall be sent to the calling MS;
- b) A C\_WACKD if more signalling will follow;
- c) After the status message has been successfully transported, a C\_ACKD(Mirrored\_Reason=MS\_accepted) PDU.

If a C\_NACKD is received, the calling MS shall abandon the status message call and return to the idle state.

If a C\_WACKD is received the MS shall start/restart the TNP\_Timer and wait for further signalling.

Any acknowledgement or valid C\_AHOY PDU received shall restart the TNP\_timer.

#### 6.6.6.1.2.1.4 Timeout waiting for further signalling

A MS waiting for further signalling shall abandon the status message service and return to the idle state if the TNP\_Timer expires.

#### 6.6.6.1.2.1.5 Called Party MS receiving a status message

If a MS receives a C\_AHOY message with the Target Address matching its individual address, it shall respond with an appropriate acknowledgement. The Service\_Options information element contains the most significant five bits of the status message. The Appended\_Blocks contains the two least significant bits of the status message.

#### 6.6.6.1.2.2 Status Message Delivery Service to a talkgroup

##### 6.6.6.1.2.2.1 Initiating the Status Message Delivery Service to the talkgroup

For a status message service request to a talkgroup, the destination address is completely expressed by the Target Address information element in the C\_RAND random access PDU. IG=1<sub>2</sub>. The Service\_Kind specifies the Status Message call service.

The calling MS shall attempt access until it receives a valid response, or the service is cancelled by the user, or the attempt fails by sending the maximum number of random access PDUs or the random access timer expires.

##### 6.6.6.1.2.2.2 Response to a random access talkgroup status message delivery service request

The calling MS shall accept the following PDUs a valid response to the status service random access request:

- a) An acknowledgement PDU C\_NACKD, C\_QACKD, C\_WACKD;
- b) A UDT Head + appended block(s) (status polling call is diverted);
- c) A C\_AHOY PDU to the called talkgroup containing the status;
- d) A C\_AHOY PDU from AUTHI (MS authentication check);
- e) A C\_AHOY PDU from SUPPLI instructing the calling MS to transport supplementary data using the UDT mechanism.

The order in which c), d), and c) shall be sent is prescribed in clause 6.4.13.

### 6.6.6.1.2.2.3 Acknowledgements received by the calling MS

When the C\_RAND PDU has been transmitted by the calling party, an initial response may be received by the calling party as specified in clause 6.6.6.1.1.3.

At any time further PDUs may be sent to the calling party as follows:

- a) A C\_WACKD if more signalling will follow.

If a C\_WACKD is received the MS shall start/restart the TNP\_Timer and wait for further signalling.

Any acknowledgement or valid C\_AHOY PDU received shall restart the TNP\_timer.

### 6.6.6.1.2.2.4 Timeout waiting for further signalling

A MS waiting for further signalling shall abandon the status message service and return to the idle state if the TNP\_Timer expires.

### 6.6.6.1.2.2.5 Talkgroup receiving a status delivery message

If a talkgroup receives a C\_AHOY message with the Target Address matching its talkgroup address, it shall store the status value but shall not send any acknowledgement.

## 6.6.6.2 Status Polling Service Procedure

The Status Message Polling procedure employs a store and forward mechanism. An MS or Gateway may request a Status Message from an individual MS.

The status polling service is differentiated from the status delivery by the calling party initiating the status service with Status = 111 1111<sub>2</sub>, (see clause 7.2.31).

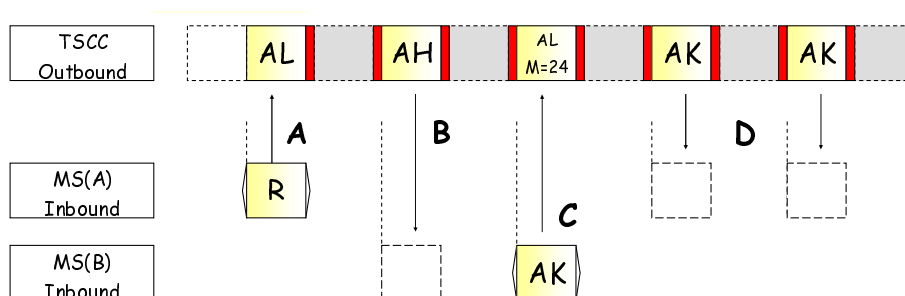

**Figure 6.51: Example of the Status Polling Service**

Figure 6.51 shows an example of a Status Polling transfer from MS to MS:

- a) "A" is the random access C\_RAND PDU. The polled party is MS(B), Service\_Kind set to 'Status' and STATUS set to 111 1111<sub>2</sub>;
- b) "B" is a C\_AHOY PDU from MS(A) that requests the polled status value from MS(B). STATUS=111 1111<sub>2</sub> is mirrored;
- c) "C" is the acknowledgement from MS(B). The acknowledgment contains the polled status value in the Information Element - Response\_Info;
- d) "D" is the final acknowledgement to the calling party MS(A). The acknowledgment contains the polled status value in Response\_Info. Note that the acknowledgement is repeated for reliability.

### 6.6.6.2.1 Status Service Polling Procedures for the TSCC

An MS initiates a Status Polling Service by random access addressed to an individual MS address. A gateway initiated poll initiates the poll with an AHOY addressed to the polled MS.



#### 6.6.6.2.1.1 TSCC Response to a Status Polling Service from an MS

When the TSCC responds to the random access request it shall start timer (TNP\_Timer). This timer shall be refreshed if the TSCC sends further call progress messages to the calling party.

On receipt of the random access service request the TSCC shall transmit either:

- a) An acknowledgement PDU C\_NACKD, C\_WACKD (Reason=Wait), C\_QACKD addressed to the calling MS;
- b) A C\_AHOY PDU addressed to the polled MS for this call to pass the status to the calling MS;
- c) A C\_AHOY PDU from AUTHI (MS authentication check);
- d) A UDT Head \_ appended block(s) (status message service is diverted. If the TS has previously accepted a call diversion indicating that this type of service request be directed to another called party, the TSCC shall invoke the UDT and send a UDT Head + Appended data to the calling party.

#### 6.6.6.2.1.2 Acknowledgements sent by the TSCC to the calling MS

The TSCC may send acknowledgement PDUs following the random access Status service request to indicate the progress of the call, or terminate the call. If the TSCC sends a PDU to indicate the progress of a call it shall start a waiting timer TNP\_Timer. (The calling party MS maintains a similar timer).

- a) Progress PDUs may be:
  - 1) C\_WACKD: Intermediate acknowledgement. More PDUs to follow.
  - 2) C\_QACKD: Called MS engaged in another call.
  - 3) C\_QACKD: Call is queued because the resource is in use at the moment.
- b) Termination PDUs are selected from an appropriate Reason information element in a C\_NACKD PDU (see clause 7.2.8).
  - 1) C\_NACKD.

#### 6.6.6.2.1.3 Delivery of the polled status to the calling party

The TSCC polls the status from the polled MS by transmitting a C\_AHOY PDU containing the Status value 111 111<sub>2</sub> information element. The C\_AHOY may have originated as a result of a random access request for a status polling service from the calling MS, a gateway or the TSCC. For a status polling service to an individual MS ID, the C\_AHOY PDU demands a response from the polled MS.

If the status poll originated from an MS then:

- a) If the response from the polled MS is C\_ACKU or C\_NACKU, the TSCC shall send an equivalent acknowledgement to the calling MS (Mirrored\_Reason). If a response is not received, the TSCC may repeat the C\_AHOY or abandon the service and indicate the failure to the calling MS by transmitting a C\_NACKD.
- b) If the response from the polled MS is C\_ACKU(Reason=Accepted for the Status Polling Service), the Information Element Response\_Info contains the polled status. The TSCC shall mirror the Response\_Info in a C\_ACKD(Mirrored\_Reason=Accepted for the Status Polling Service). This mirrored response from the TSCC may be repeated for reliability.

#### 6.6.6.2.1.4 Call Time Out

The TSCC shall maintain a timeout defining the maximum time it shall store a status message request waiting for the called MS or TSCC resource to become free.

#### 6.6.6.2.2 Status Polling Service Procedures for MS

A MS requests a status polling message call service to an individual MS using a single part service request.

A MS requests a Status Polling Service by sending a C\_RAND random access request complying with the random access procedures in clause 6.2. The information elements in the random access request are passed to the CC layer - set appropriately as prescribed in table 6.48.

**Table 6.48: C\_RAND information elements for a Status Polling Service**

Information Element (I.E)	I.E Length	length	Alias	Value	Remark
Service Options	1		IG	0 <sub>2</sub>	The target address is an MS individual ID
	1		Supplementary _user Data	0 <sub>2</sub>	No supplementary_user data transfer requested
				1 <sub>2</sub>	Supplementary_user data is requested for this call
	5		STATUS(5)	1 1111 <sub>2</sub>	Most significant 5 bits of the STATUS (see note 4)
Proxy Flag	1		PROXY	0 <sub>2</sub>	Number of Extended BCD digits for addressing through a gateway = 1 to 20
				1 <sub>2</sub>	Number of Extended BCD digits for addressing through a gateway = 21 to 44
Appended_Supplementary_Data	2		SUPED_VAL	Value	Number of appended UDTs required to transport supplementary data
	2		STATUS(2)	11 <sub>2</sub>	Least significant 2 bits of the STATUS (see note 4)
Service_Kind	4		IND_ST_SRV	0111 <sub>2</sub>	Status Transport Service
Target_address or Gateway	24			Value	Target Address (see note 2)
Source_address	24			Value	Individual Address of the requesting MS
NOTE 1: Privacy is not defined in the present document.					
NOTE 2: Target_Address represents an Individual address.					
NOTE 3: If SUPED_SV = 0 <sub>2</sub> then SUPED_VAL = 00 <sub>2</sub> .					
NOTE 4: The STATUS = 111 1111 <sub>2</sub> indicates the Status Polling Service.					

#### 6.6.6.2.2.1 Status Polling Service addressed to an individual MS

##### 6.6.6.2.2.1.1 Initiating the Status Message Polling Service to the MS or gateway

For a status message polling service request from an individual MS, the destination address is completely expressed by the Target Address information element in the C\_RAND random access PDU. IG=0<sub>2</sub>. The Service\_Kind specifies the Status Message call service.

The MS shall attempt access until it receives a valid response, or the service is cancelled by the user, or the attempt fails by sending the maximum number of random access PDUs or the random access timer expires.

##### 6.6.6.2.2.1.2 Response to a random access status polling message service request

The calling MS shall accept the following PDUs a valid response to the status service random access request:

- An acknowledgement PDU C\_NACKD, C\_QACKD, C\_WACKD;
- A UDT Head + appended block(s) (UDT short data call is diverted);
- A C\_AHOY PDU to the polled MS containing the status value = 111 1111<sub>2</sub>;
- A C\_AHOY PDU from AUTHI (MS authentication check);
- A C\_AHOY PDU instructing the calling MS to transport supplementary data using the UDT mechanism.

NOTE: d) and e) may be performed in any order.

### 6.6.6.2.2.1.3 Acknowledgements received by the calling MS

When the C\_RAND PDU has been transmitted by the calling party, an initial response may be received by the calling party as specified in clause 6.6.6.2.1.2.

At any time further PDUs may be sent to the calling party as follows:

- A C\_NACKD at any time to indicate the call has failed. The Reason information element shall be set to indicate the reason for the call failure. If the C\_NACKD sent to the calling MS is the result of a C\_NACK from the called MS, a mirrored\_reason code shall be sent to the calling MS;
- A C\_WACKD if more signalling will follow;
- After the status message has been successfully transported, a C\_ACKD PDU (mirrored\_reason).

If a C\_NACKD is received, the calling MS shall abandon the status message call and return to the idle state.

If a C\_WACKD is received the MS shall start/restart the TNP\_Timer and wait for further signalling.

Any acknowledgement or valid C\_AHOY PDU received shall restart the TNP\_timer.

### 6.6.6.2.2.1.4 Timeout waiting for further signalling

A MS waiting for further signalling shall abandon the status message service and return to the idle state if the TNP\_Timer expires.

### 6.6.6.2.2.1.5 MS receiving a status message

If a MS receives a C\_AHOY message with the Target Address matching its individual address, it shall respond with an appropriate acknowledgement. The Response\_Info Information Element contains the polled status.

## 6.6.7 Call Diversion

### 6.6.7.1 Call Diversion Service

The call diversion service supports a self initiated diversion - that is a MS may request that all future services be redirected to an alternative destination. Requests are applicable to:

- Voice call service;
- Packet Data service;
- UDT Short data message delivery service;
- Status message service.

Applicable Services may be redirected to another MS, a talkgroup, or an extended\_address through a gateway.

The "Set Diversion" call diversion service uses a multi-part call set-up and the diversion address is sent by the caller using the UDT mechanism. This is recognized by the DIVONOFF information element in the diversion service request set to "Set Call Diversion" (=1<sub>2</sub>).

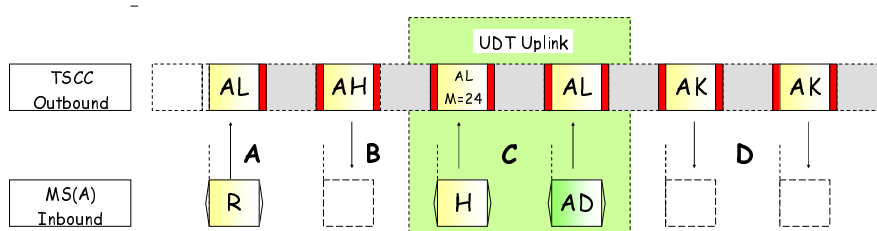

Figure 6.52: Example of a Call Diversion Call

- a) MS(A) defines the number of appended UDTs needed to transport the diverted address to the TSCC. In this example, one appended UDT is required.
- b) "A" is the random access C\_RAND PDU. The Service\_Kind set to 'Call Diversion Service' and the Appended\_Short\_Data PDU to the number of UDT appended blocks to transport the diverted address.
- c) "B" is a C\_AHOY PDU from DIVERTI that requests MS(A) to transport the diversion address using the UDT mechanism.
- d) "C" is the inbound phase consisting of a Multi-block UDT header + appended data transporting the diverted address to the TSCC.
- e) "D" is the acknowledgement from the TSSC.

If the Service\_Options information element DIVONOFF in the call diversion Service request is set to "Clear Diversion" then a single part call set-up with the Target Address set to DIVERTI.

#### 6.6.7.1.1 TSCC Procedures for the Call Diversion Service

A MS initiates a Set Call Diversion Service by random access addressed to the gateway identifier appropriate to the diverted destination - individual MS address, talkgroup, PSTN, PABX or IP. The set call diversion service uses the multi-part call set-up. When the TSCC responds to the random access request it shall start timer (TNP\_Timer). This timer shall be refreshed if the TSCC sends further call progress PDUs to the calling party.

A MS initiates a Clear Call Diversion Service by random access addressed to the gateway identifier DIVERTI. The clear call diversion service uses the single-part call set-up. When the TSCC responds to the random access request it shall start timer (TNP\_Timer). This timer shall be refreshed if the TSCC sends further call progress PDUs to the calling party.

A MS initiates a Clear Incoming Call Diversion Service by random access addressed to the gateway identifier DIVERTI. The clear incoming call diversion service also uses the single-part call set-up.

##### 6.6.7.1.1.1 TSCC Response to a multi-part Set Call Diversion Service call setup

To set call diversion service, the MS generates a random access diversion service request with the C\_RAND information elements set as table 6.51 and the DIVONOFF information element set to Set Call Diversion (=1<sub>2</sub>).

The PDUs that shall represent a valid response to the set call diversion service multi-part random access request are:

- a) An acknowledgement PDU C\_NACKD, C\_WACKD(reason=Wait). The source Address=the target address from the C\_RAND, the target address=source address from the C\_RAND.
- b) A C\_AHOY PDU from DIVERTI for the calling MS to send the diverted address using the UDT mechanism.
- c) A C\_AHOY PDU, Source Address=Authentication Challenge Value (MS authentication check).

For b) the TSCC shall invoke the UDT procedure by sending a C\_AHOY to the calling MS to send the diverted address information. For a call diversion to the PABX or PSTN the diverted address information shall be BCD digits. The Proxy Flag information element in the C-AHOY PDU shall be copied from the Proxy Flag information element received from the MS C\_RAND PDU. If the TSCC does not successfully receive the UDT from the MS, the TSCC may repeat the C\_AHOY, or transmit a C\_NACKD to indicate failure of the call.

The gateway target information elements for C\_UDTHU PDU is prescribed in table 6.49. The appended blocks contain the diverted address.

**Table 6.49: UDT Header Target information elements for the Set Call Diversion Service**

Action	Gateway Address	Remark
Send the individual MS Address	MS ID	The calling party shall send the MS Individual diversion address
Send the Talkgroup Address	GPI	The calling party shall send the MS talkgroup diversion address
Send PSTN digits	PSTNI	The calling party shall send BCD dialled digits
Send PABX digits	PABXI	The calling party shall send BCD dialled digits
Send LINE digits	LINEI	The calling party shall send BCD dialled digits
Send Dispatcher digits	DISPATI	The calling party shall send BCD dialled digits
Send IP address	IPI	The calling party shall send the IPV4 or IPV6 address

#### 6.6.7.1.1.2 Final acknowledgement to the MS

In the inbound phase, the MS sends the diverted address to the TSCC.

The TSCC shall send an appropriate final acknowledgement acknowledgement. (The source Address=the target address from the C\_RAND that initiated the call diversion, the target address=source address from the C\_RAND that initiated the call diversion;) to the calling party to indicate the outcome of the call diversion.

The acknowledgements that represent a valid response to the inbound diverted address are prescribed in table 6.50.

**Table 6.50: Acknowledgements to a Set Call Diversion Service**

Acknowledgement	Reason Code	Remark
C_ACK	0110 0000 <sub>2</sub>	Call Diversion accepted by the TS
C_NACK	0010 0000 <sub>2</sub>	Acknowledgement to the initial request for call diversion if the system does not support call diversion (see note)
C_NACK	0010 0011 <sub>2</sub>	The call may not be diverted to this destination (see note)
NOTE: If call diversion is not supported by this system, the TSCC sends a C_NACK Reason Code = 0010 0000 <sub>2</sub> to the initial random access. If the system cannot set the diversion to the destination indicated by the MS in the upload diversion address phase, the TSCC sends the C_NACK Reason Code = 0010 0011 <sub>2</sub> as the final acknowledgement.		

#### 6.6.7.1.1.3 TSCC Response to a single-part Clear Call Diversion Service set-up

For the clear call diversion service, the MS generates a random access diversion service request with the C\_RAND information elements set as table 6.51 and the DIVONOFF information element set to Clear Call Diversion (=0<sub>2</sub>).

The PDUs that shall represent a valid response to the clear call diversion service multi-part random access request are:

- An acknowledgement PDU C\_NACKD indicating that the service request has not succeeded.
- C\_WACKD(reason=Wait) further signalling to follow.
- An acknowledgement C\_ACKD indicating that the service request has succeeded.
- A C\_AHOY PDU from AUTHI (MS authentication check).

NOTE: The C\_WACKD response permits the call diversion service to proceed after the call has been queued.

#### 6.6.7.1.2 MS Procedures for the Call Diversion Service

A MS requests the call diversion service using a random access service request.

If the MS wishes to divert its calls the DIVONOFF information element in the Service\_Options is set to "Set Diversion (=1<sub>2</sub>)". A multi-part service request is invoked. The information elements in the random access request are passed to the CC layer - set appropriately as prescribed in table 6.51.

If the MS wishes to cancel a previously set diversion, the same random access request is.

**Table 6.51: C\_RAND information elements for a Call Diversion Service**

Information Element (I.E)	I.E Length	length	Alias	Value	Remark
Service_Options	7	1	EMERG	Not applicable - 0 <sub>2</sub>	
		1		0 <sub>2</sub>	Privacy (see note)
		1	DIVONOFF	0 <sub>2</sub>	Clear Call Diversion
				1 <sub>2</sub>	Set Call Diversion
		1	DIV_VD	Active 1 <sub>2</sub>	Divert Voice Calls
		1	DIV_PD		Divert Packet Data Calls
		1	DIV_SD	Inactive 0 <sub>2</sub>	Divert Short Data Calls
1	DIV_S	Divert Status Calls			
Proxy Flag	1		PROXY	0 <sub>2</sub>	Number of Extended BCD digits for addressing through a gateway = 1 to 20 or IPV4
				1 <sub>2</sub>	Number of Extended BCD digits for addressing through a gateway = 21 to 44 or IPV6
Reserved	2			00 <sub>2</sub>	
Appended_Short_Data	2		SDATA_VAL	00 <sub>2</sub>	Number of UDT appended blocks to transport the diverted address
Service_Kind	4		DIV_SRV	1000 <sub>2</sub>	Call Diversion Service
Target_address or Gateway	24			Value	Gateway Identifier. For call diversion -MSI, GPI, PSTNI, PABXI or IPI. For clear call diversion - DIVERTI.
Source_address	24			Value	Individual Address of the requesting MS
NOTE: Privacy is not defined in the present document.					

If DIVONOFF=1<sub>2</sub>, the alias DIV\_VD, DIV\_PD, DIV\_SD and DIV\_S that are set to Active (1<sub>2</sub>): define which services shall be diverted for this call diversion service request.

If DIVONOFF=0<sub>2</sub>, the alias DIV\_VD, DIV\_PD, DIV\_SD and DIV\_S that are set to Active (1<sub>2</sub>): define which services shall have the call diversion cancelled.

**Table 6.52: Information element definitions for the Call Diversion Service**

Diversion Address	Target Address or Gateway	Proxy Flag
Individual MS Address	MSI	0 <sub>2</sub>
Talkgroup Address	GPI	0 <sub>2</sub>
PSTN Address (1 to 20 dialled digits)	PSTNI	0 <sub>2</sub>
PSTN Address (21 to 44 dialled digits)	PSTNI	1 <sub>2</sub>
PABX Address(1 to 20 dialled digits)	PABXI	0 <sub>2</sub>
PABX Address (21 to 44 dialled digits)	PABXI	1 <sub>2</sub>
Ipv4 Address	IPI	0 <sub>2</sub>
Ipv6 Address	IPI	1 <sub>2</sub>

#### 6.6.7.1.2.1 MS Sends the Diversion Address

After the MS has made a call diversion service request, the TSCC sends a C\_AHOY PDU to which the MS shall respond with a UDT Header + Appended block(s) using the UDT mechanism. The UDT header shall contain the destination address type (MS, PSTN, etc.) and the appended block(s) shall contain the diversion address.

The information elements for the UDT inbound Header are specified in table 6.53.

Table 6.53: Information element Definitions for the Call Diversion UDT Header

Diversion Address	UDT Inbound Channel Header Information Element			
	UDT Format	Appended Blocks	Target Address or Gateway	Source Address or Gateway
Individual MS	Address - 0001 <sub>2</sub>	00 <sub>2</sub>	MSI	MS Address
Talkgroup	Address - 0001 <sub>2</sub>	00 <sub>2</sub>	GPI	MS Address
PSTN destination	BCD - 0010 <sub>2</sub>	1 to 20 digits - 00 <sub>2</sub> 21 to 44 digits - 01 <sub>2</sub>	PSTNI	MS Address
PABX destination	BCD - 0010 <sub>2</sub>	1 to 20 digits - 00 <sub>2</sub> 21 to 44 digits - 01 <sub>2</sub>	PABXI	MS Address
LINE Destination	BCD - 0010 <sub>2</sub>	1 to 20 digits - 00 <sub>2</sub> 21 to 44 digits - 01 <sub>2</sub>	LINEI	MS Address
Dispatcher Destination	BCD - 0010 <sub>2</sub>	1 to 20 digits - 00 <sub>2</sub> 21 to 44 digits - 01 <sub>2</sub>	DISPATI	MS Address
IP destination	IP -0110 <sub>2</sub>	IPV4 - 00 <sub>2</sub> IPV6 - 01 <sub>2</sub>	IPI	MS Address
NOTE: Supplementary_Flag = 0 <sub>2</sub> , UDT_Response = 0 <sub>2</sub> , Service_Kind = 1000 <sub>2</sub> , UDT_DIV = 1 <sub>2</sub>				

## 6.6.7.1.2.2 Recipient of Diverted Calls Cancels All Incoming Diversions

If the recipient of call diversions (MS) wishes to cancel all incoming diversions, the MS generates a random access service request with the C\_RAND information elements set as table 6.54.

Table 6.54: C\_RAND information elements for a Cancel Incoming Diversions

Information Element (I.E)	I.E Length	length	Alias	Value	Remark
Service_Options	7	1	EMERG	Not applicable - 0 <sub>2</sub>	
		1		0 <sub>2</sub>	Privacy (see note)
		1	DIVONOFF	0 <sub>2</sub>	Clear Call Diversion
		1	DIV_VD	Active 1 <sub>2</sub>	Clear Divert Voice Calls
		1	DIV_PD		Clear Divert Packet Data Calls
		1	DIV_SD	Inactive 0 <sub>2</sub>	Clear Divert Short Data Calls
		1	DIV_S		Clear Divert Status Calls
Proxy Flag	1		PROXY	0 <sub>2</sub>	Not defined for Cancel Incoming Diversions
Appended_Supplementary_Data	2		SUPED_VAL	00 <sub>2</sub>	Not Defined for the call diversion Service
Appended_Short_Data	2		SDATA_VAL	00 <sub>2</sub>	Not Defined for the call diversion Service
Service_Kind	4		DIV_SRV	1000 <sub>2</sub>	Call Diversion Service
Target_address or Gateway	24			Value	DIVERTI
Source_address	24			Value	Individual Address of the requesting MS
NOTE: Privacy is not defined in the present document.					

## 6.6.7.1.2.3 TSCC Response to the Cancel Incoming Diversions Request

For the cancel incoming call diversions, the PDUs that shall represent a valid response are:

- An acknowledgement PDU C\_NACKD indicating that the service request has not succeeded;
- C\_WACKD(reason=Wait) further signalling to follow;

- c) An acknowledgement C\_ACKD (Source=DIVERTI, Destination=MS Individual Ident) indicating that the request has succeeded;
- d) A C\_AHOY PDU from AUTHI (MS authentication check).

### 6.6.7.2 Diverting Calls

An MS makes a service access request by random access. If the destination address selected is an individual MS address and the system determines that calls to this address are diverted, the TSCC shall acknowledge the random access request with a UDT header + appended with the diverted address.

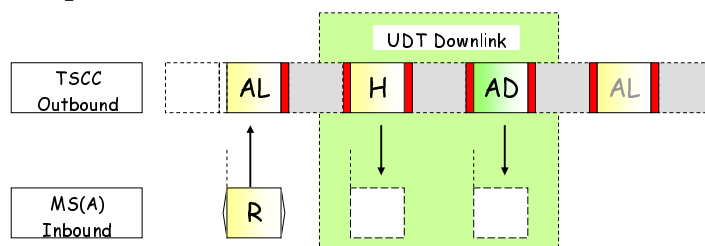

**Figure 6.53: TSCC provides diverted address to MS**

The UDT Header sets the following information elements:

- Supplementary Flag = 1<sub>2</sub>.
- UDT Response - 0<sub>2</sub>.
- Target\_address or Gateway - Address of the calling MS.

Where the appended UDT block conveys an address the ADDRESS1 information element shall convey the diverted address.

Table 6.55 indicates the UDT Header information elements for the services and diversion addresses.

**Table 6.55: Information elements for UDT Header to convey diverted address**

Service Request	Divert to	UDT Header information elements			
		UDT Format	Appended Blocks	Service_Kind	Source Address
Private Voice	MS address	Address 0001 <sub>2</sub>	00 <sub>2</sub>	0000 <sub>2</sub>	MSI
	Talkgroup	Address 0001 <sub>2</sub>	00 <sub>2</sub>		GPI
	PSTN	BCD 0010 <sub>2</sub>	1 to 20 digits - 00 <sub>2</sub> 21 to 44 digits - 01 <sub>2</sub>		PSTNI
	PABX	BCD 0010 <sub>2</sub>	1 to 20 digits - 00 <sub>2</sub> 21 to 44 digits - 01 <sub>2</sub>		PABXI
Private Packet Data	MS address	Address 0001 <sub>2</sub>	00 <sub>2</sub>	0010 <sub>2</sub>	MSI
	Talkgroup	Address 0001 <sub>2</sub>	00 <sub>2</sub>		GPI
	PSTN	BCD 0010 <sub>2</sub>	1 to 20 digits - 00 <sub>2</sub> 21 to 44 digits - 01 <sub>2</sub>		PSTNI
	PABX	BCD 0010 <sub>2</sub>	1 to 20 digits - 00 <sub>2</sub> 21 to 44 digits - 01 <sub>2</sub>		PABXI
	IP	IP 0110 <sub>2</sub>	IPV4 - 00 <sub>2</sub> IPV6 - 01 <sub>2</sub>		IPI



Service Request	Divert to	UDT Header information elements			
		UDT Format	Appended Blocks	Service_Kind	Source Address
Short Data	MS address	Address 0001 <sub>2</sub>	00 <sub>2</sub>	0100 <sub>2</sub>	MSI
	Talkgroup	Address 0001 <sub>2</sub>	00 <sub>2</sub>		GPI
	PSTN	BCD 0010 <sub>2</sub>	1 to 20 digits - 00 <sub>2</sub> 21 to 44 digits - 01 <sub>2</sub>		PSTNI
	PABX	BCD 0010 <sub>2</sub>	1 to 20 digits - 00 <sub>2</sub> 21 to 44 digits - 01 <sub>2</sub>		PABXI
	IP	IP 0110 <sub>2</sub>	IPV4 - 00 <sub>2</sub> IPV6 - 01 <sub>2</sub>		IPI
Status	MS address	Address 0001 <sub>2</sub>	00 <sub>2</sub>	0111 <sub>2</sub>	MSI
	PSTN	BCD 0010 <sub>2</sub>	1 to 20 digits - 00 <sub>2</sub> 21 to 44 digits - 01 <sub>2</sub>		PSTNI
	PABX	BCD 0010 <sub>2</sub>	1 to 20 digits - 00 <sub>2</sub> 21 to 44 digits - 01 <sub>2</sub>		PABXI
	IP	IP 0110 <sub>2</sub>	IPV4 - 00 <sub>2</sub> IPV6 - 01 <sub>2</sub>		IPI

## 6.7 System Management Procedures

### 6.7.1 Network System Announcements

Announcement PDUs are transmitted by a TSCC and contain information about system parameters for either this TS or another TS. Announcement PDUs may be transmitted frequently and therefore contain the System Identity Code for TSCC identification.

Announcement Type (BCASTTYP) specifies which system parameters are being broadcast:

- a) Announce/Withdraw TSCC.
- b) Specify Call Timer Parameters.
- c) Vote Now Advice.
- d) Announce Local Time.
- e) Mass registration.
- f) Announce a logical/physical frequency plan relationship.
- g) Adjacent site information.

#### 6.7.1.1 Announce/Withdraw TSCC

This announcement adds and/or withdraws a TSCC radio channel that is active in a wide area system. The announcement PDU carries up to two Logical Physical Channel Number Elements. If only one Logical Channel Number is announced, the remaining element shall be set to CHNULL. MSs shall add/withdraw the logical channel(s) to/from their Short Hunt list of physical channels to hunt (see annex D).

### 6.7.1.2 Specify Call Timer parameters

This PDU specifies the call timer parameters for:

- a) Calls between MS and MS or MS and a talkgroup.
- b) Calls between a Line Connected Service and an MS or Talkgroup.
- c) Calls that use the Packet Data Service.
- d) Emergency Calls.

### 6.7.1.3 Vote now advice

The Network System Announcements (Vote Now Advice) PDU gives an opportunity to idle MSs to assess the signal quality of another TSCC specified by the announcement. The PDU provides a sub-set of the system identity code (C\_SYSCode), and the logical channel number (CH\_VOTE) of the TSCC the MS is being invited to assess for improved signal quality.

While MSs are assessing an adjacent TSCC, they are not able to receive call set-up PDUs. The TSCC shall therefore not use the next VOTE\_BLK TDMA frames (see clause A.2) to signal to MSs that are likely to be assessing the adjacent site. Only the following PDUs may be transmitted on the TSCC in the VOTE\_BLK slots following transmission of a Vote Now Advice announcement:

- a) An Aloha PDU with MS Address = NULL and Mask=24.
- b) A C\_WACKD.

The trunked radio network may wish to influence on which TSCC an MS acquires. This may not be the site that is offering the best quality signal (as measured by signal strength, BER or other means).

Two strategies of operation may be employed:

- 1) 'Radiated Preference Strategy'. The priorities of the sites are radiated in the Vote Now Advice. The MS shall use these priorities in conjunction with signal quality to determine which TSCC to acquire or remain on.
- 2) 'No Radiated Preference Strategy'. The priorities of the sites are not radiated in the Vote Now Advice and the MS is free to use whatever criteria it is customized with to acquire or remain on a site. For example this may be a simple comparison of signal quality or it may utilize programmed values of priority per TSCC (Ch\_Pref) (see clause A.2).

The strategy to be utilized is indicated by a combination of fields in the Vote Now Advice. These are explained below. (their position in the Broadcast ParmS field is described in clause 7.2.19.3);

**System Identity Code** (14 bits) – The MS 14 bits of the C\_SYSCode radiated on the adjacent site. This can be used by the confirmed MS to determine the C\_SYSCode being radiated by the adjacent site without having to tune to that TSCC and sample it.

**Channel Number** (12 bits) – The physical channel number of the adjacent site to be sampled.

**Active Connection Available Flag** (1 bit) – This flag is set if the status of the adjacent sites network connection is known and available. This is necessary because this information may not be known by the confirmed site (for example if it has lost its own network connection). If set the MS may utilize the 'Active Connection' flag in its analysis of the adjacent site. If this flag is clear the MS shall ignore the Active Connection flag.

**Active Connection Flag** (1 bit) – Defined elsewhere in this spec. Indicates that the adjacent site has full connectivity with the rest of the network. The radio may utilize this information when assessing the suitability of the adjacent site.

**Confirmed Channel Priority** (3 bits) and **Adjacent Channel Priority** (3 bits) – These fields convey the priority of the current (confirmed) site and the priority of the adjacent site to be sampled. The values contained in these fields are described in table 6.56.

**Table 6.56: Channel Priority**

Value	Meaning
1	Preferred Site - Highest Priority
2	Preferred Site - Priority 2
3	Preferred Site - Priority 3
4	Preferred Site - Priority 4
5	Preferred Site - Priority 5
6	Preferred Site - Priority 6
7	Preferred Site - Lowest Priority
0	Non-Preferred Site

The MS may utilize these priorities in determining which site to acquire or remain on. The exact algorithm to be utilized is manufacturer proprietary and hence is not specified in the present document.

The value 0 (non-preferred) is used to indicate that no preference data will be radiated and the MS is free to utilize its own methods of determining priorities by use of Ch\_Pref data. Normally therefore a TS will either radiate all Vote Now Advice broadcasts with preference priorities or it shall radiate all Vote Now Advice broadcasts with no preference priority. The consequences of mixing them would have to be carefully understood or otherwise it could lead to very unpredictable behaviour.

It should be noted that by using Vote Now Advice messages with the Syscode and Channel Number set as appropriate and all other fields set to 0, this re-creates the format of the Vote Now Advice broadcasts as specified in TS 102 361-4 [i.1] V1.4.1 and earlier. That is, there will be no indication of Active Connection and both confirmed and adjacent site priorities are non-preferred.

#### 6.7.1.4 Announce Local Time

This PDU transmits the local date and time to MSs. The PDU permits the date and UTC\_OFFSET to be omitted from the announcement.

If UTC\_OFFSET  $\neq$  '11111' then

$$\text{UTC time} = (\text{B\_HOURS} + \text{UTC\_OFFSET} + \text{UTC\_OFFSET\_FRACTION}) \text{ MOD } 24$$

#### 6.7.1.5 Mass Registration

This PDU invites all MS or a sub-set of MS to register over a short or extended time period. The description and procedures are specified in the registration clauses 6.4.5.

#### 6.7.1.6 Announce a logical physical channel relationship

This PDU announces a logical to physical channel relationship. The PDU defines the physical transmitter and receiver frequencies to be assigned to a logical channel.

#### 6.7.1.7 Adjacent Site Information

This PDU announces information about the TSCCs in use on radio sites in the vicinity of this TSCC to assist MS to acquire an appropriate TSCC if the MS moves out of radio contact with the current TSCC.

The broadcast PDU contains both the logical channel number and C\_SYScode which is being transmitted by the announced TSCC.

The action to be taken by the MS on receipt of this PDU is not prescribed in the present document but the following comments are offered for the benefit of designers implementing processes that use Adjacent Site information:

- When searching for a valid TSCC the MS hunts through a list of candidate physical channels until an appropriate TSCC is selected and confirmed. The data received in the Adjacent Site PDU may be used to modify the TSCC search in favour of radio channels which are more likely to provide a satisfactory service than other radio channels which the search parameters may specify.

---

## 7 PDU description

This clause describes the PDUs which apply to the DMR layer 3, the Tier III trunking services and facilities protocol.

The following clauses contain descriptions of the PDUs and the information elements contained within them. The structure of the PDU definition represented by the tables is as follows:

- the information element column gives the name of the contained element(s);
- the element length column defines the length of the element in bits;
- the Alias used in the description of the procedures;
- the remarks column contains other information on the information element.

The elements shall be transmitted in the order specified by TS 102 361-1 [5].

### 7.1 Layer 3 PDUs

Due to the nature of DMR, with close interaction between layers 2 and 3, and with a high degree of information about the state of the channel being needed, the layer 3 PDUs detailed in the following clauses may include two element types:

- Message dependent elements:
  - These elements are visible to layer 2 and may be used by any MS (that is able to decode them), irrespective of addressing. These elements depend on the message type element. Some are generated by layer 2 when it constructs the complete message whereas others are generated by layer 3.
- Facility elements:
  - These are "true" layer 3 elements. They are only processed by the MSs to which they are addressed.

Where both types exist in the PDU they are illustrated separately.

#### 7.1.1 Control Signalling Block (CSBK/MBC/UDT) PDUs

CSBK/MBC and UDT PDUs form a core part of the Tier III protocol. The control signalling PDUs are classified into their core functionality.

The Call Control Layer 3 requires three Data Type bursts (see TS 102 361-1 [5], clause 6.2). These are listed in:

- table 7.1 for TSCC outbound PDUs;
- table 7.2 for TSCC inbound PDUs;
- table 7.3 for Payload channel outbound PDUs; and
- table 7.4 for Payload inbound PDUs.

Table 7.1: TSCC Outbound channel PDU Structure

Class	Alias	Function	Opcode	Data Type	Value
Broadcast	PV_GRANT	Private Voice Channel Grant (logical)	11 0000 <sub>2</sub>	CSBK	0011 <sub>2</sub>
		Private Voice Channel Grant (absolute)		MBC Header	0100 <sub>2</sub>
Broadcast	TV_GRANT	Talkgroup Voice Channel Grant (logical)	11 0001 <sub>2</sub>	CSBK	0011 <sub>2</sub>
		Talkgroup Voice Channel Grant (absolute)		MBC Header	0100 <sub>2</sub>
Broadcast	BTV_GRANT	Broadcast Talkgroup Voice Channel Grant (logical)	11 0010 <sub>2</sub>	CSBK	0011 <sub>2</sub>
		Broadcast Talkgroup Voice Channel Grant (absolute)		MBC Header	0100 <sub>2</sub>
Broadcast	PD_GRANT	Private Data Channel Grant (logical)	11 0011 <sub>2</sub>	CSBK	0011 <sub>2</sub>
		Private Data Channel Grant (absolute)		MBC Header	0100 <sub>2</sub>
Broadcast	TD_GRANT	Talkgroup Data Channel Grant (logical)	11 0100 <sub>2</sub>	CSBK	0011 <sub>2</sub>
		Talkgroup Data Channel Grant (absolute)		MBC Header	0100 <sub>2</sub>
Broadcast	CG_AP	Channel Grant Appended MBC	Value from header	MBC Continuation	0101 <sub>2</sub>
Broadcast	C_MOVE	Move TSCC (logical)	11 1001 <sub>2</sub>	CSBK	0011 <sub>2</sub>
		Move TSCC (absolute)		MBC Header	0100 <sub>2</sub>
Broadcast	MV_AP	Move Appended MBC	11 1000 <sub>2</sub>	MBC Continuation	0101 <sub>2</sub>
Broadcast	C_ALOHA	Aloha	01 1001 <sub>2</sub>	CSBK	0011 <sub>2</sub>
Broadcast (C_BCAST)	Ann_WD_TSCC	Announce/Withdraw TSCC (logical)	10 1000 <sub>2</sub>	CSBK	0011 <sub>2</sub>
		Announce/Withdraw TSCC (absolute)		MBC Header	0100 <sub>2</sub>
	CallTimer_Parms	Specify Call Timer Parameters		CSBK	0011 <sub>2</sub>
	Vote_Now	Vote Now Advice		CSBK	0011 <sub>2</sub>
	Local_Time	Broadcast Local Time		CSBK	0011 <sub>2</sub>
	MassReg	Broadcast Mass Registration		CSBK	0011 <sub>2</sub>
	Chan_Freq	Announce a logical channel / frequency relationship		MBC Header	0100 <sub>2</sub>
	Adjacent Site	Broadcast Adjacent Site Information		CSBK	0011 <sub>2</sub>
Broadcast	BC_AP	Broadcast Appended MBC	10 1000 <sub>2</sub>	MBC Continuation	0101 <sub>2</sub>
Ahoy (AHOY)	AHOY	Stun/Revive/Kill Poll MS MS Check	01 1100 <sub>2</sub>	CSBK	0011 <sub>2</sub>
Acknowledgements	C_ACKD	Positive Acknowledgement	10 0000 <sub>2</sub>	CSBK	0011 <sub>2</sub>
	C_NACKD	Negative Acknowledgement			
	C_QACKD	Acknowledgement			
	C_WACKD	The call is queued Wait - further PDUs follow			
Unified Data Transport	C_UDTHD	Unified Data Transport Header	N/A	Data Header (UDT)	0110 <sub>2</sub>
Unified Data Transport	UDT	Unified Data Transport Appended Data	N/A	Unconfirmed Data Continuation	0111 <sub>2</sub>

**Table 7.2: TSCC Inbound Channel PDU Structure**

Class	Alias	Function	Opcode	Data Type	Value
Random Access	C_RAND	Random Access Requests	01 1111 <sub>2</sub>	CSBK	0011 <sub>2</sub>
Ackvitation	C_ACKVIT	Ackvitation	01 1110 <sub>2</sub>	CSBK	0011 <sub>2</sub>
Acknowledgement	C_ACKU C_NACKU	Acknowledgement	10 0001 <sub>2</sub>	CSBK	0011 <sub>2</sub>
Unified Data Transport	C_UDTHD	Unified Data Transport Header	N/A	Data Header (UDT)	0110 <sub>2</sub>
Unified Data Transport	UDT	Unified Data Transport Appended Data	N/A	Unconfirmed Data Continuation	0111 <sub>2</sub>

**Table 7.3: Payload Outbound channel PDU Structure**

Class	Alias	Function	Opcode	Data Type	Value
Broadcast	P_GRANT	Channel Grant (logical)	Value from Chan Grant	CSBK	0011 <sub>2</sub>
		Channel Grant (absolute)		MBC Header	0100 <sub>2</sub>
Broadcast (Clear)	P_CLEAR	Clear the call from the payload channel. MS return to the TSCC	10 1110 <sub>2</sub>	CSBK	0011 <sub>2</sub>
Broadcast (Protect)	P_PROTECT	Channel Protection	10 1111 <sub>2</sub>	CSBK	0011 <sub>2</sub>
AHOY	P_AHOY	MS Check	01 1100 <sub>2</sub>	CSBK	0011 <sub>2</sub>
Acknowledgements	P_ACKD P_NACKD	Positive Acknowledgement Negative Acknowledgement	10 0010 <sub>2</sub>	CSBK	0011 <sub>2</sub>

**Table 7.4: Payload Inbound Channel PDU Structure**

Class	Alias	Function	Opcode	Data Type	Value
Random Access	P_RAND	Random Access Include Request	01 1111 <sub>2</sub>	CSBK	0011 <sub>2</sub>
Acknowledgement	P_ACKU	Acknowledgement	10 0011 <sub>2</sub>	CSBK	0011 <sub>2</sub>
Maintenance	P_MAINT	Call Maintenance	10 1010 <sub>2</sub>	CSBK	0011 <sub>2</sub>

Figure 7.1 illustrates the hierarchy of the TSCC outbound channel PDU structure.

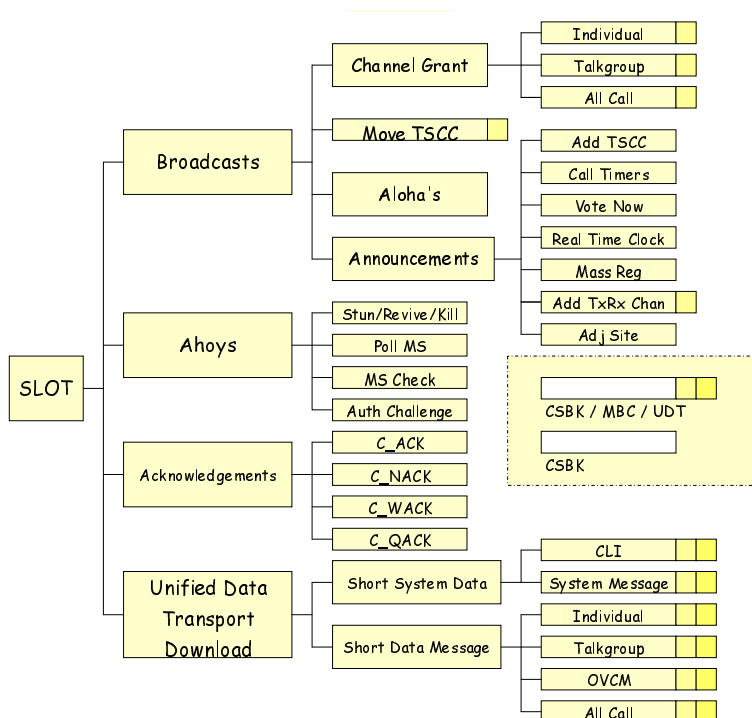

Figure 7.1: Hierarchy for the TSCC outbound channel PDUs

The top level of the structure describes a basic behaviour illustrated in table 7.5.

Table 7.5: Top Level Structure for TSCC Outbound channel CSBKs / MBCs /UDTs

Broadcasts	PDUs sent by a TSCC to manage the channel access, transfer MS or talkgroups to payload channels and announce information about the TS
Ahoys	To demand a response from MS and also to acknowledge random access channel access
Acknowledgments	To provide responses to UDT
UDT	To transport information between TSCC and MS

A similar structure exists for the inbound channel illustrated in figure 7.2.

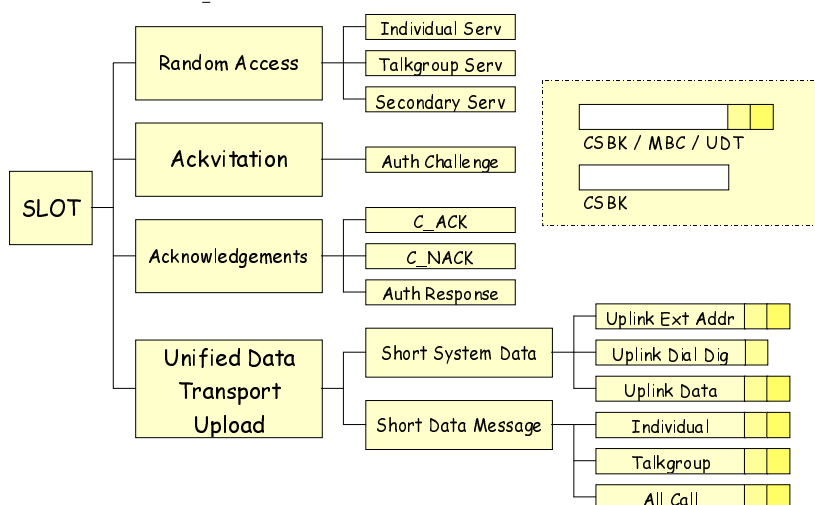

Figure 7.2: Hierarchy for the MS inbound channel PDUs to a TSCC

The basic PDU behaviour for the inbound channel is illustrated in table 7.6.

**Table 7.6: Top level structure for MS on the TSCC inbound**

Random Access	Used for channel access and request Tier III services
Acknowledgments	To provide responses to Ahoys and UDT
UDT	To transport information between MS and TSCC

A payload channel outbound channel is illustrated in figure 7.3.

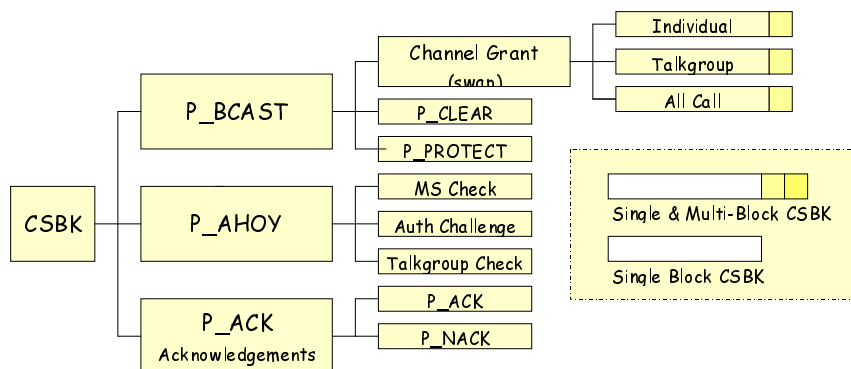

**Figure 7.3: Hierarchy for Outbound channel CSBKs/MBCs on a payload channel**

The top level of the structure describes a basic behaviour illustrated in table 7.7.

**Table 7.7: Top level structure for MS inbound channel CSBKs on a control channel**

Broadcasts	PDUs sent by TS to manage the payload channel - swap MS to a new channel, clear the participants from the channel and protect the channel during breaks in MS transmission items
Ahoys	For polling MS - demands a response
Acknowledgments	To provide responses to Ahoys and UDT

The payload inbound channel.

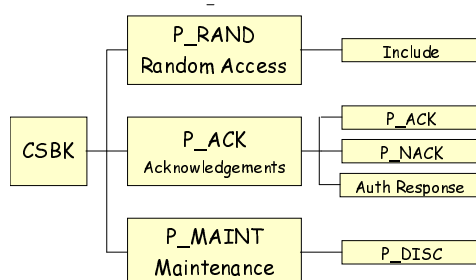

**Figure 7.4: Hierarchy for the MS inbound channel PDUs to a payload channel**

The basic PDU behaviour for the inbound channel is illustrated in table 7.8.

**Table 7.8: Top level structure for MS on the payload channel inbound channel**

Random Access	Used to request an include call service
Acknowledgments	To provide responses to Ahoys and UDT
Maintenance	To provide call maintenance PDUs



7.1.1.1 TSCC Outbound channel CSBK/MBC/UDT

7.1.1.1.1 Channel Grant CSBK/MBC PDU

7.1.1.1.1.1 Private Voice Channel Grant (PV\_GRANT) CSBK/MBC PDU

Octet 0 and 1 of the Private Voice Channel Grant CSBK PDU conforms to the LC format structure as defined in figure 7.1 in TS 102 361-1 [5] of the standard with the CSBKO replacing the FLCO. Octets 2 to 9 contain the Private Voice Channel Grant specific information illustrated in table 7.9. The Private Voice Channel Grant is transmitted by the TS and does not solicit a response. The Private Voice Channel Grant PDU is transmitted on the TSCC or a payload channel either as a single block CSBK or a Multi Block Control (MBC). For the Physical Channel Number Information Element:

- a) If the value = 0000 0000 0000<sub>2</sub> the Physical Channel number is invalid.
- b) If the value = 0000 0000 0001<sub>2</sub> to 1111 1111 1110<sub>2</sub>, the Physical Channel number represent a logical channel number for the physical transmitter and receiver frequency. The Private Voice Channel Grant PDU is transmitted on the TSCC as a single block CSBK.
- c) If the value = 1111 1111 1111<sub>2</sub>, the Physical Channel number defines a multi-block MBC where the absolute transmitter and receiver frequency is defined in a second block concatenated to this block (defined in clause 7.1.1.1.2).

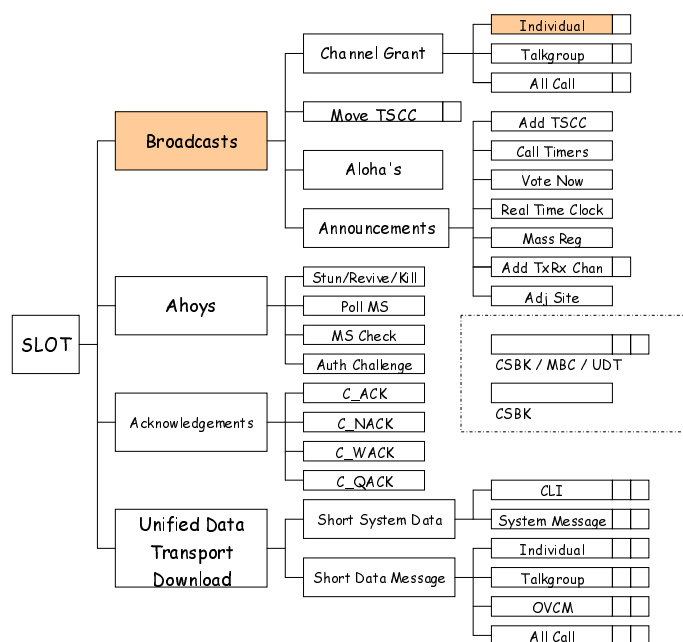

Figure 7.5

Table 7.9: Private Voice Channel Grant PDU content

Information element	Length	Remark
<b>Message dependent elements</b>		
Last block (LB)	1	This bit shall be set to 1 <sub>2</sub> for a single block CSBK or 0 <sub>2</sub> if this is a MBC header
Protect Flag (PF)	1	
<b>Feature elements</b>		
CSBK Opcode (CSBKO)	6	Shall be set to 11 0000 <sub>2</sub>
Feature set ID (FID)	8	Shall be set to 0000 0000 <sub>2</sub>
Logical Physical Channel Number	12	Payload Channel for the Call or an indicator that the absolute Tx and Rx frequency is specified in an appended CSBK block
Logical Channel Number	1	0 <sub>2</sub> - TDMA channel 1 1 <sub>2</sub> - TDMA channel 2
OVCN	1	0 <sub>2</sub> - not OVCN call 1 <sub>2</sub> - OVCN Call
Emergency	1	0 <sub>2</sub> - not an emergency call 1 <sub>2</sub> - emergency call
Offset	1	0 <sub>2</sub> - Payload Channel uses aligned timing 1 <sub>2</sub> - Payload Channel uses offset timing
Target Address	24	Called party Individual MS Address or Gateway
Source Address	24	Calling Party or Gateway

#### 7.1.1.1.1.2 Talkgroup Voice Channel Grant (TV\_GRANT) CSBK/MBC PDU

Octet 0 and 1 of the Talkgroup Voice Channel Grant CSBK PDU conforms to the LC format structure as defined in figure 7.1 in TS 102 361-1 [5] of the standard with the CSBKO replacing the FLCO. Octets 2 to 9 contain the Talkgroup Voice Channel Grant specific information illustrated in table 7.10. The Talkgroup Voice Channel Grant is transmitted by the TS. The Talkgroup Voice Channel Grant is transmitted by the TS and does not solicit a response. The Talkgroup Voice Channel Grant PDU is transmitted on the TSCC or a payload channel either as a single block CSBK or a Multi Block Control (MBC). For the Physical Channel Number Information Element:

- a) If the value = 0000 0000 0000<sub>2</sub> the Physical Channel number is invalid.
- b) If the value = 0000 0000 0001<sub>2</sub> to 1111 1111 1110<sub>2</sub>, the Physical Channel number represent a logical channel number for the physical transmitter and receiver frequency. The Talkgroup Voice Channel Grant PDU is transmitted on the TSCC as a single block CSBK.
- c) If the value = 1111 1111 1111<sub>2</sub>, the Physical Channel number defines a Multi Block Control (MBC) where the absolute transmitter and receiver frequency is defined in a second block concatenated to this block (defined in clause 7.1.1.1.2).

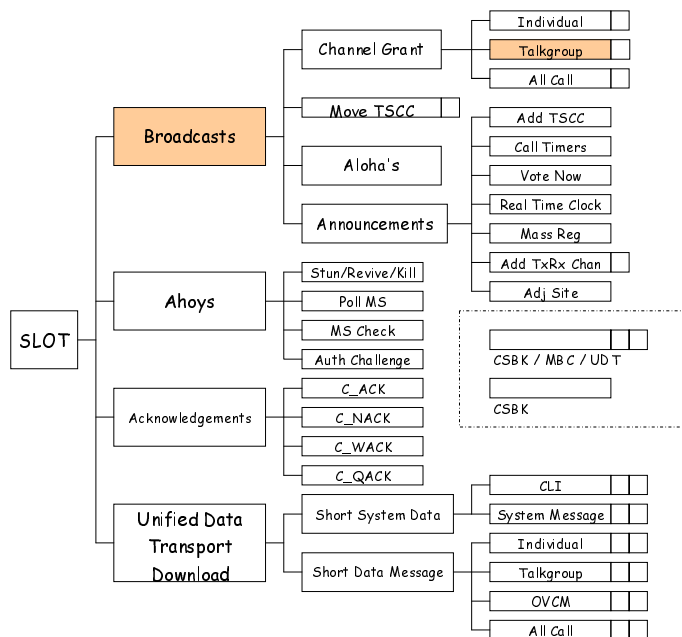

Figure 7.6

Table 7.10: Talkgroup Voice Channel Grant PDU content

Information element	Length	Remark
<b>Message dependent elements</b>		
Last block (LB)	1	This bit shall be set to 1 <sub>2</sub> for a single block CSBK or 0 <sub>2</sub> if this is a MBC header
Protect Flag (PF)	1	
<b>Feature elements</b>		
CSBK Opcode (CSBKO)	6	Shall be set to 110001 <sub>2</sub>
Feature set ID (FID)	8	Shall be set to 0000 0000 <sub>2</sub>
Logical Physical Channel Number	12	Payload Channel for the Call or an indicator that the absolute Tx and Rx frequency is specified in an appended CSBK block
Logical Channel Number	1	0 <sub>2</sub> - TDMA channel 1 1 <sub>2</sub> - TDMA channel 2
OVCM	1	0 <sub>2</sub> - not OVCM call 1 <sub>2</sub> - OVCM Call
Emergency	1	0 <sub>2</sub> - not an emergency call 1 <sub>2</sub> - emergency call
Offset	1	0 <sub>2</sub> - Payload Channel uses aligned timing 1 <sub>2</sub> - Payload Channel uses offset timing
Target Address	24	MS Talkgroup Address
Source Address	24	Calling Party or Gateway

If the Target Address is the All\_Unit Address ID15 (see TS 102 361-1 [5], annex A) then a MS shall interpret this PDU as a broadcast.

7.1.1.1.1.3 Broadcast Talkgroup Voice Channel Grant (BTV\_GRANT) CSBK/MBC PDU

Octet 0 and 1 of the Broadcast Talkgroup Voice Channel Grant CSBK PDU conforms to the LC format structure as defined in figure 7.1 in TS 102 361-1 [5] of the standard with the CSBKO replacing the FLCO. Octets 2 to 9 contain the Broadcast Talkgroup Voice Channel Grant specific information illustrated in table 7.11. The Broadcast Talkgroup Voice Channel Grant is transmitted by the TS and does not solicit a response. The Broadcast Talkgroup Voice Channel Grant PDU is transmitted on the TSCC or a payload channel either as a single block CSBK or a Multi Block Control (MBC). For the Physical Channel Number Information Element:

- a) If the value = 0000 0000 0000<sub>2</sub> the Physical Channel number is invalid.

- b) If the value = 0000 0000 0001<sub>2</sub> to 1111 1111 1110<sub>2</sub>, the Physical Channel number represent a logical channel number for the physical transmitter and receiver frequency. The Broadcast Talkgroup Voice Channel Grant is transmitted on the TSCC as a single block CSBK.
- c) If the value = 1111 1111 1111<sub>2</sub>, the Physical Channel number defines a Multi-Block Control (MBC) where the absolute transmitter and receiver frequency is defined in a second block concatenated to this block (defined in clause 7.1.1.1.2).

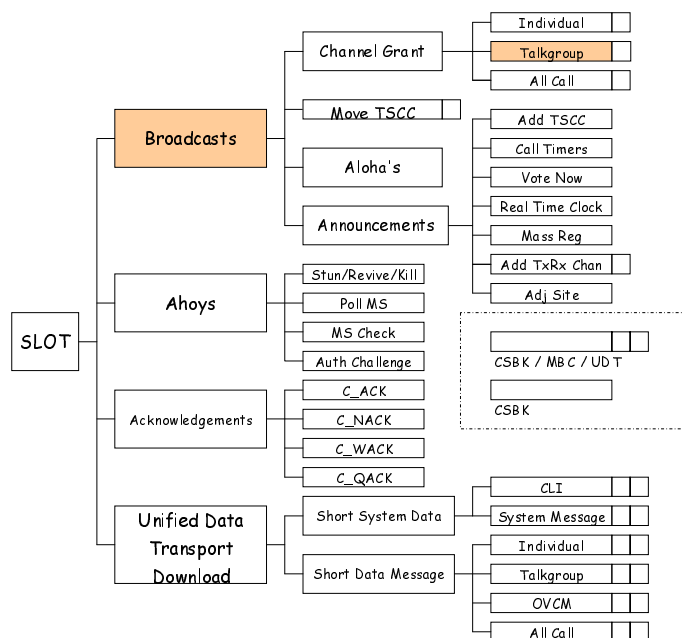

Figure 7.7

Table 7.11: Broadcast Talkgroup Voice Channel Grant PDU content

Information element	Length	Remark
<b>Message dependent elements</b>		
Last block (LB)	1	This bit shall be set to 1 <sub>2</sub> for a single block CSBK or 0 <sub>2</sub> if this is a MBC header
Protect Flag (PF)	1	
<b>Feature elements</b>		
CSBK Opcode (CSBKO)	6	Shall be set to 110010 <sub>2</sub>
Feature set ID (FID)	8	Shall be set to 0000 0000 <sub>2</sub>
Logical Physical Channel Number	12	Payload Channel for the Call or an indicator that the absolute Tx and Rx frequency is specified in an appended CSBK block
Logical Channel Number	1	0 <sub>2</sub> - TDMA channel 1 1 <sub>2</sub> - TDMA channel 2
OVCM	1	0 <sub>2</sub> - not OVCM call 1 <sub>2</sub> - OVCM Call
Emergency_Flag	1	1 <sub>2</sub> -if an emergency call
Offset	1	0 <sub>2</sub> - Payload Channel uses aligned timing 1 <sub>2</sub> - Payload Channel uses offset timing
Destination_address	24	MS Talkgroup Address. See Note
Source_address	24	Calling Party or Gateway
NOTE: Addresses for All Call are ALLMSID, ALLMSIDZ and ALLMSIDL.		

7.1.1.1.1.4 Private Data Channel Grant (PD\_GRANT) CSBK/MBC PDU

Octet 0 and 1 of the Private Data Channel Grant CSBK PDU conforms to the LC format structure as defined in figure 7.1 in TS 102 361-1 [5] of the standard with the CSBKO replacing the FLCO. Octets 2 to 9 contain the Private Channel Grant specific information illustrated in table 7.12. The Private Data Channel Grant is transmitted by the TS and does not solicit a response. The Private Data Channel Grant PDU is transmitted on the TSCC or a payload channel either as a single block CSBK or a Multi Block Control (MBC). For the Physical Channel Number Information Element:

- a) If the value = 0000 0000 0000<sub>2</sub> the Physical Channel number is invalid.
- b) If the value = 0000 0000 0001<sub>2</sub> to 1111 1111 1110<sub>2</sub>, the Physical Channel number represent a logical channel number for the physical transmitter and receiver frequency. The Private Data Channel Grant PDU is transmitted on the TSCC as a single block CSBK.
- c) If the value = 1111 1111 1111<sub>2</sub>, the Physical Channel number defines a Multi Block Control (MBC) where the absolute transmitter and receiver frequency is defined in a second block concatenated to this block (defined in clause 7.1.1.1.2).

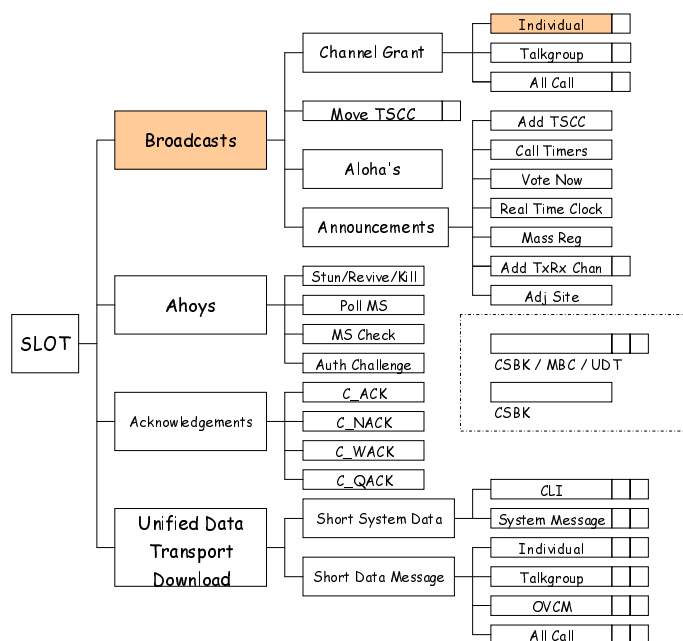

Figure 7.8

Table 7.12: Private Data Channel Grant PDU content

Information element	Length	Remark
<b>Message dependent elements</b>		
Last block (LB)	1	This bit shall be set to 1 <sub>2</sub> for a single block CSBK or 0 <sub>2</sub> if this is a MBC header
Protect Flag (PF)	1	
<b>Feature elements</b>		
CSBK Opcode (CSBKO)	6	Shall be set to 11 0011 <sub>2</sub>
Feature set ID (FID)	8	Shall be set to 0000 0000 <sub>2</sub>
Logical Physical Channel Number	12	Payload Channel for the Call or an indicator that the absolute Tx and Rx frequency is specified in an appended CSBK block
Logical Channel Number	1	0 <sub>2</sub> - TDMA channel 1 1 <sub>2</sub> - TDMA channel 2
Packet Mode	1	0 <sub>2</sub> - Payload Channel uses 2:1 mode 1 <sub>2</sub> - Payload Channel uses 1:1 mode
Emergency	1	0 <sub>2</sub> - not an emergency call 1 <sub>2</sub> - emergency call
Offset	1	0 <sub>2</sub> - Payload Channel uses aligned timing 1 <sub>2</sub> - Payload Channel uses offset timing
Destination_address	24	Called party Individual MS Address or Gateway
Source_address	24	Calling Party or Gateway

#### 7.1.1.1.1.5 Talkgroup Data Channel Grant (TD\_GRANT) CSBK/MBC PDU

Octet 0 and 1 of the Talkgroup Data Channel Grant CSBK PDU conforms to the LC format structure as defined in figure 7.1 in TS 102 361-1 [5] of the standard with the CSBKO replacing the FLCO. Octets 2 to 9 contain the Talkgroup Data Channel Grant specific information illustrated in table 7.13. The Talkgroup Data Channel Grant is transmitted by the TS and does not solicit a response. The Talkgroup Data Channel Grant PDU is transmitted on the TSCC or a payload channel either as a single block CSBK or a Multi Block Control (MBC). For the Physical Channel Number Information Element:

- a) If the value = 0000 0000 0000<sub>2</sub> the Physical Channel number is invalid.
- b) If the value = 0000 0000 0001<sub>2</sub> to 1111 1111 1110<sub>2</sub>, the Physical Channel number represent a logical channel number for the physical transmitter and receiver frequency. The Talkgroup Data Channel Grant PDU is transmitted on the TSCC as a single block CSBK.
- c) If the value = 1111 1111 1111<sub>2</sub>, the Physical Channel number defines a Multi Block Control (MBC) where the absolute transmitter and receiver frequency is defined in a second block concatenated to this block (defined in clause 7.1.1.1.2).

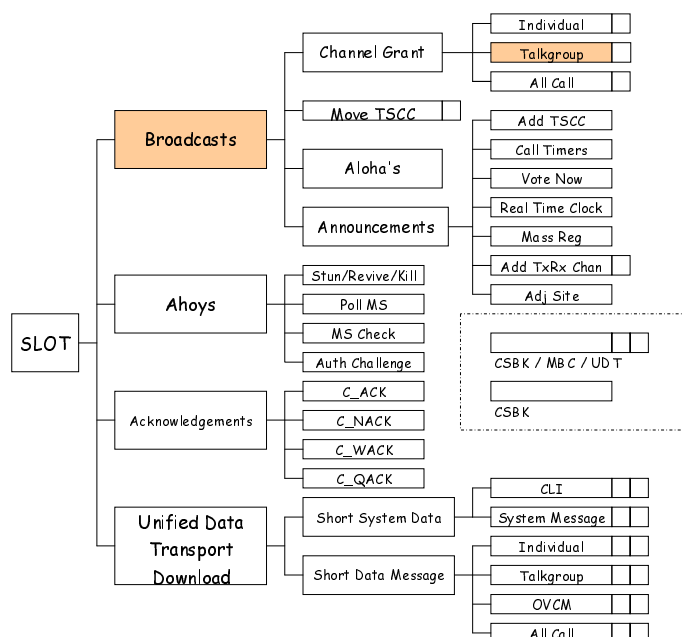

Figure 7.9

Table 7.13: Talkgroup Data Channel Grant PDU content

Information element	Length	Remark
<b>Message dependent elements</b>		
Last block (LB)	1	This bit shall be set to 1 <sub>2</sub> for a single block CSBK or 0 <sub>2</sub> if this is a MBC header
Protect Flag (PF)	1	
<b>Feature elements</b>		
CSBK Opcode (CSBKO)	6	Shall be set to 11 0100 <sub>2</sub>
Feature set ID (FID)	8	Shall be set to 0000 0000 <sub>2</sub>
Logical Physical Channel Number	12	Payload Channel for the Call or an indicator that the absolute Tx and Rx frequency is specified in an appended CSBK block
Logical Channel Number	1	0 <sub>2</sub> - TDMA channel 1 1 <sub>2</sub> - TDMA channel 2
Packet Mode	1	0 <sub>2</sub> - Payload Channel uses 2:1 mode 1 <sub>2</sub> - Payload Channel uses 1:1 mode
Emergency	1	0 <sub>2</sub> - not an emergency call 1 <sub>2</sub> - emergency call
Offset	1	0 <sub>2</sub> - Payload Channel uses aligned timing 1 <sub>2</sub> - Payload Channel uses offset timing
Destination_Address	24	MS Talkgroup Address
Source_address	24	Calling Party or Gateway

#### 7.1.1.1.2 Channel Grant Absolute Parameters (CG\_AP) appended MBC PDU

The second (continuation) block of the multi-block Channel Grant MBC conforms to the format specified in table 7.14. The CdefParms PDU is specified in clause 7.2.19.7 and the physical characteristics described in annex C.

Table 7.14: C\_DEF appended Channel Grant MBC PDU content

Information element	Length	Remark
<b>Message dependent elements</b>		
Last block (LB)	1	This bit shall be set to 1 <sub>2</sub> because this PDU is appended to either a an applicable Channel Grant MBC Header
Protect Flag (PF)	1	
<b>Feature elements</b>		
CSBK Opcode (CSBKO)	6	Shall be set to the CSBKO of the first block of the multi-block CSBK
Reserved	4	0000 <sub>2</sub>
Colour Code	4	Colour Code used for the destination physical channel
Cdeftype	4	Meaning of CdefParms (see clause 7.2.19.7)
Reserved	2	00 <sub>2</sub>
CdefParms	58	Information elements describing the logical / physical channel frequency relationship

7.1.1.1.3 Move TSCC (C\_MOVE) CSBK/MBC PDU

Octet 0 and 1 of the Move TSCC CSBK PDU conforms to the LC format structure as defined in figure 7.1 in TS 102 361-1 [5] of the standard with the CSBKO replacing the FLCO. Octets 2 to 9 contain the Move TSCC specific information illustrated in table 7.15. The Move PDU is transmitted on the TSCC either as a single block CSBK or a Multi Block Control (MBC). For the Physical Channel Number Information Element:

- a) If the value = 0000 0000 0000<sub>2</sub> the Physical Channel number is invalid.
- b) If the value = 0000 0000 0001<sub>2</sub> to 1111 1111 1110<sub>2</sub>, the Physical Channel number represent a logical channel number for the physical transmitter and receiver frequency. The Move PDU is transmitted on the TSCC as a single block CSBK.
- c) If the value = 1111 1111 1111<sub>2</sub>, the Physical Channel number defines a Multi Block Control (MBC) where the absolute transmitter and receiver frequency is defined in a second block concatenated to this block (see clause 7.1.1.1.3.1).

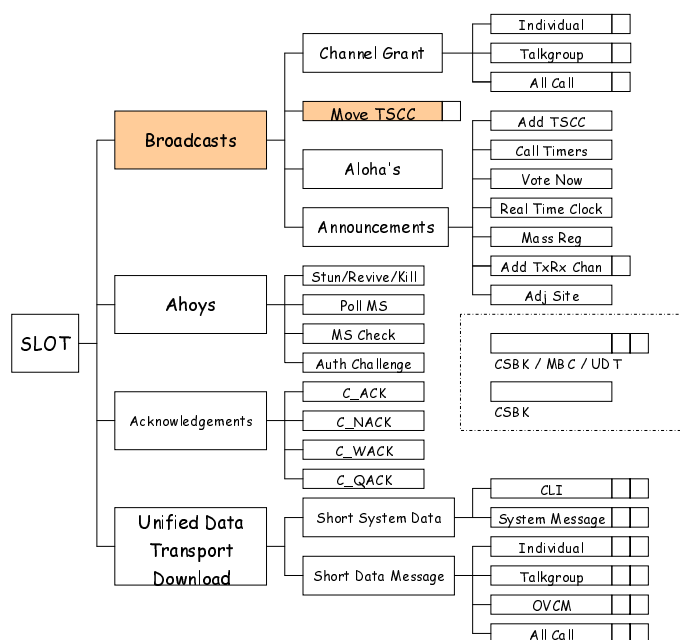

Figure 7.10



Table 7.15: Move TSCC PDU content

Information element	Length	Remark
<b>Message dependent elements</b>		
Last First block (LB)	1	This bit shall be set to 1 <sub>2</sub> for a single block CSBK or 0 <sub>2</sub> if this is a MBC header
Protect Flag (PF)	1	
<b>Feature elements</b>		
CSBK Opcode (CSBKO)	6	Shall be set to 11 1001 <sub>2</sub>
Feature set ID (FID)	8	Shall be set to 0000 0000 <sub>2</sub>
Reserved	9	0 0000 0000 <sub>2</sub>
Mask	5	
Reserved	5	
Reg	1	This bit is set if the TSCC demands MS register before becoming active
Backoff	4	Backoff Number
Reserved	4	
Physical Channel Number	12	Payload Channel for the Call or an indicator that the absolute Tx & Rx frequency is specified in an appended CSBK block
MS address	24	MS Individual Address

#### 7.1.1.1.3.1 Move Absolute Parameters appended (MV\_AP) MBC PDU

The second block of the Multi Block Move MBC conforms to the format specified in table 7.16. The CdefParms PDU is specified in clause 7.2.19.7 and the physical characteristics described in annex C.

Table 7.16: C\_DEF appended Move MBC PDU content

Information element	Length	Remark
<b>Message dependent elements</b>		
Last block (LB)	1	This bit shall be set to 1 <sub>2</sub> because this PDU is appended to an applicable Move MBC Header
Protect Flag (PF)	1	
<b>Feature elements</b>		
CSBK Opcode (CSBKO)	6	Shall be set to the CSBKO of the first block of the multi-block CSBK
Reserved	4	0000 <sub>2</sub>
Colour Code	4	Colour Code used for the destination physical channel
Cdeftype	4	Meaning of CdefParms (see clause 7.2.19.7)
Reserved	2	00 <sub>2</sub>
CdefParms	58	information elements describing the logical / physical channel frequency relationship

#### 7.1.1.1.4 Aloha (C\_ALOHA) CSBK PDU

Octet 0 and 1 of the C\_ALOHA CSBK PDU conforms to the LC format structure as defined in figure 7.1 in TS 102 361-1 [5] of the standard with the CSBKO replacing the FLCO. Octets 2 to 9 contain the C\_ALOHA PDU specific information. The C\_ALOHA PDU is illustrated in table 7.17. C\_ALOHA PDUs are transmitted by a TSCC.

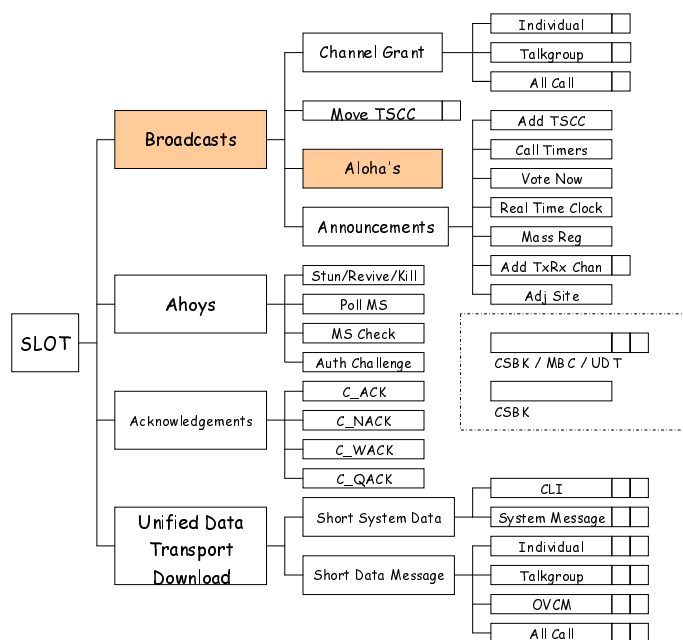

Figure 7.11

Table 7.17: C\_ALOHA PDU content

Information element	Length	Remark
<b>Message dependent elements</b>		
Last block (LB)	1	This bit shall be set to 1 <sub>2</sub>
Protect Flag (PF)	1	
<b>Feature elements</b>		
CSBK Opcode (CSBKO)	6	Shall be set to 01 1001 <sub>2</sub>
Feature set ID (FID)	8	Shall be set to 0000 0000 <sub>2</sub>
Reserved	3	
Version	3	Document Version Control
Reserved	1	0 <sub>2</sub> - Reserved
Active_Connection	1	0 <sub>2</sub> - The TS does not have a connection with the network 1 <sub>2</sub> - The TS has a connection with the network
Mask	5	
Service Function	2	
NRand_Wait	4	
Reg	1	This bit is set if the TSCC demands MS register before becoming active
Backoff	4	Backoff Number
System Identity Code	16	
MS Address	24	MS Individual Address

The C\_ALOHA PDU contains the Information Element Version to advise MS of the version number of TS 102 361-4 [i.1] to which the system is compliant (see clause 7.2.32).

#### 7.1.1.1.5 Announcements (C\_BCAST) CSBK/MBC PDU

Octet 0 and 1 of the C\_BCAST PDU conforms to the LC format structure as defined in figure 7.1 in TS 102 361-1 [5] of the standard with the CSBKO replacing the FLCO. Octets 2 to 9 contain the C\_BCAST PDU specific information. The C\_BCAST PDU is transmitted on the TSCC either as a single block CSBK or a Multi Block Control (MBC).

The C\_BCAST PDU is illustrated in table 7.18.

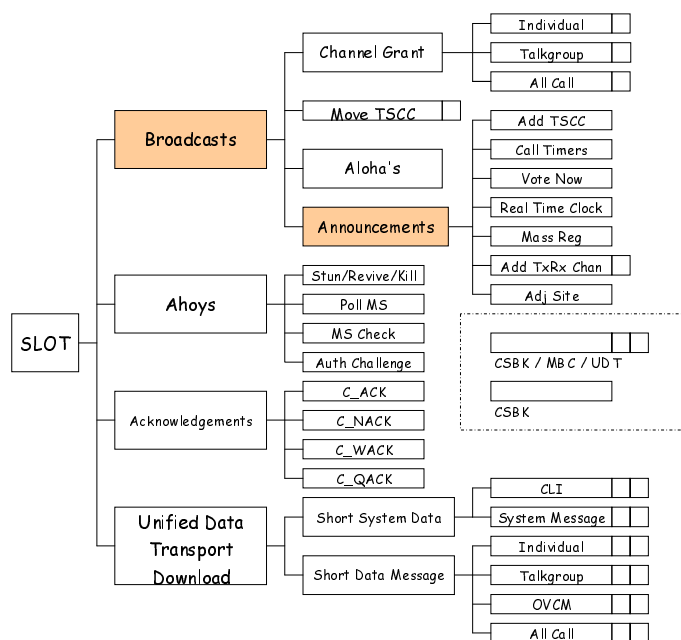

Figure 7.12

Table 7.18: C\_BCAST PDU content

Information element	Length	Remark
<b>Message dependent elements</b>		
Last block (LB)	1	This bit shall be set to 1 <sub>2</sub> for a single block CSBK or 0 <sub>2</sub> if this is a MBC header
Protect Flag (PF)	1	
<b>Feature elements</b>		
CSBK Opcode (CSBKO)	6	Shall be set to 10 1000 <sub>2</sub>
Feature set ID (FID)	8	Shall be set to 0000 0000 <sub>2</sub>
Announcement type	5	Defines which system parameters are being broadcast
Broadcast Parms 1	14	
Reg	1	This bit is set if the TSCC demands MS register before becoming active
Backoff	4	Backoff Number
System Identity Code	16	
Broadcast Parms 2	24	

The Announcement type PDU determines the category of Announcements:

- a) Announce/Withdraw TSCC.
- b) Specify call Timers.
- c) Vote now advice.
- d) Announce local time.
- e) Broadcast Mass Registration.
- f) Announce a logical physical channel relationship.
- g) Announce adjacent site information.

7.1.1.1.5.1 Broadcast Absolute Parameters (BC\_AP) appended MBC PDU

The second block of the multi-block Broadcast Absolute Parameters MBC (announce logical/absolute frequency relationship) conforms to the format specified in table 7.19. The CdefParms PDU is specified in clause 7.2.19.7 and the physical characteristics described in annex C.

**Table 7.19: BC\_AP appended Broadcast MBC PDU content**

Information element	Length	Remark
<b>Message dependent elements</b>		
Last block (LB)	1	This bit shall be set to 1 <sub>2</sub> because this PDU is appended to an applicable Announcement MBC Header
Protect Flag (PF)	1	
<b>Feature elements</b>		
CSBK Opcode (CSBKO)	6	Shall be set to the CSBKO of the first block of the multi-block CSBK
Reserved	8	
Cdeftype	4	
Reserved	2	
CdefParms	58	Information elements describing the logical / physical channel frequency relationship

7.1.1.1.6 AhoY (AHOY) CSBK PDU

Octet 0 and 1 of the AHOY CSBK PDU conforms to the LC format structure as defined in figure 7.1 in TS 102 361-1 [5] of the standard with the CSBKO replacing the FLCO. Octets 2 to 9 contain the C\_AHOY specific information. The generic AHOY PDU is illustrated in table 7.20. AHOY PDUs are transmitted by the TS.

The AHOY PDU is transmitted by the TS as a single block CSBK.

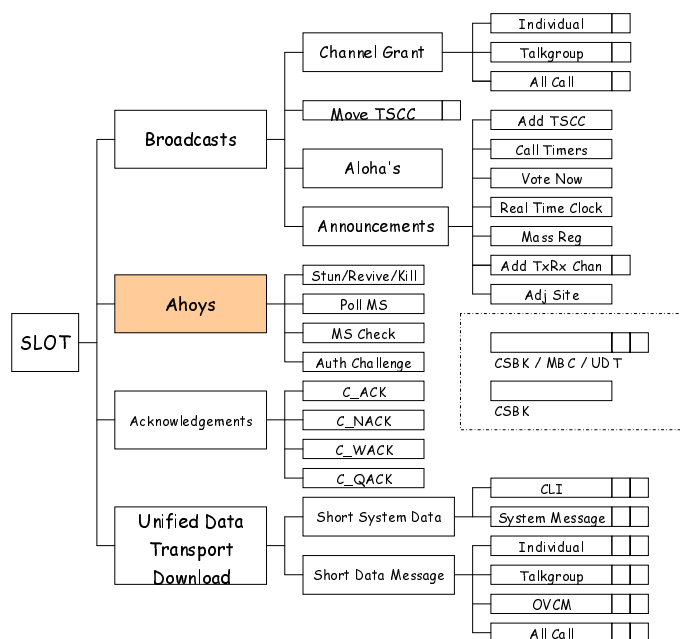

**Figure 7.13**

Table 7.20: AHOY PDU content

Information element	Length	Remark
<b>Message dependent elements</b>		
Last block (LB)	1	This bit shall be set to 1 <sub>2</sub>
Protect Flag (PF)	1	
<b>Feature elements</b>		
CSBK Opcode (CSBKO)	6	Shall be set to 01 1100 <sub>2</sub>
Feature set ID (FID)	8	Shall be set to 0000 0000 <sub>2</sub>
Service_Options_Mirror	7	See Note 2
Service_Kind_Flag	1	Meaning dependent on Service_Kind
Ambient Listening Service	1	0 <sub>2</sub> - The calling party has not requested ALS 1 <sub>2</sub> - The calling party has requested ALS (See note 1)
IG	1	0 <sub>2</sub> - The Target address is an MS individual ID 1 <sub>2</sub> - The Target address is a talkgroup
Appended_Blocks (STATUS(2))	2	For a demand to the MS to send a multi-block CSBK, the number of appended data blocks. See Note 2
Service_Kind	4	Service for which this C_AHOY is supporting
Target address	24	Address of Called MS or talkgroup
Source Address or Gateway	24	Address of calling party MS or gateway, or Authentication challenge value
NOTE 1: ALS is only applicable for an individual MS voice call.		
NOTE 2: For the status service: Appended_Blocks contains the two least significant bits of the status value. The Service_Options_Mirror contains the most significant 5 bits of the status value.		

7.1.1.1.7 Acknowledgement C\_ACKD) TSCC Response CSBK PDU

Octet 0 and 1 of the Acknowledge Response (C\_ACKD) CSBK PDU conforms to the LC format structure as defined in figure 7.1 in TS 102 361-1 [5] of the standard with the CSBKO replacing the FLCO. Octets 2 to 9 contain the Acknowledge Response specific information. The generic Acknowledge Response PDU is illustrated in table 7.21.

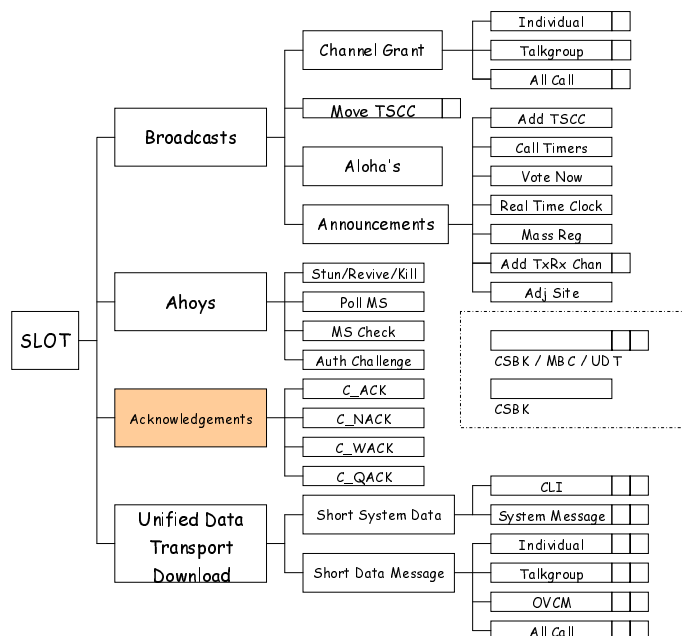

Figure 7.14

NOTE: Acknowledgement Responses are transmitted by both TS and MS.

Table 7.21: TS Acknowledgement Response PDU content

Information element	Length	Remark
<b>Message dependent elements</b>		
Last block (LB)	1	This bit shall be set to 1 <sub>2</sub>
Protect Flag (PF)	1	
<b>Feature elements</b>		
CSBK Opcode (CSBKO)	6	Shall be set to 10 0000 <sub>2</sub>
Feature set ID (FID)	8	Shall be set to 0000 0000 <sub>2</sub>
Response_Info	7	Supplementary response information
Reason Code	8	
Reserved	1	This bit shall be set to 0 <sub>2</sub>
Target address	24	Address of Called MS
Additional Information (Source Address)	24	Address of calling party MS or gateway

Acknowledge Response PDUs are arranged into classes:

- C\_ACKD - Positive Acknowledgement.
- C\_NACKD - Negative Acknowledgement.
- C\_QACKD - Queued.
- C\_WACKD - Intermediate Acknowledgement.

7.1.1.1.8 Unified Data Transport Outbound Header (C\_UDTHD) UDT PDU

This PDU is a multi-block UDT conforming to the format specified in table 7.22. The number of UDT Appended data blocks is indicated by the Appended Blocks (UAB) information element.

The UDT Appended Data Format is prescribed in annex B.

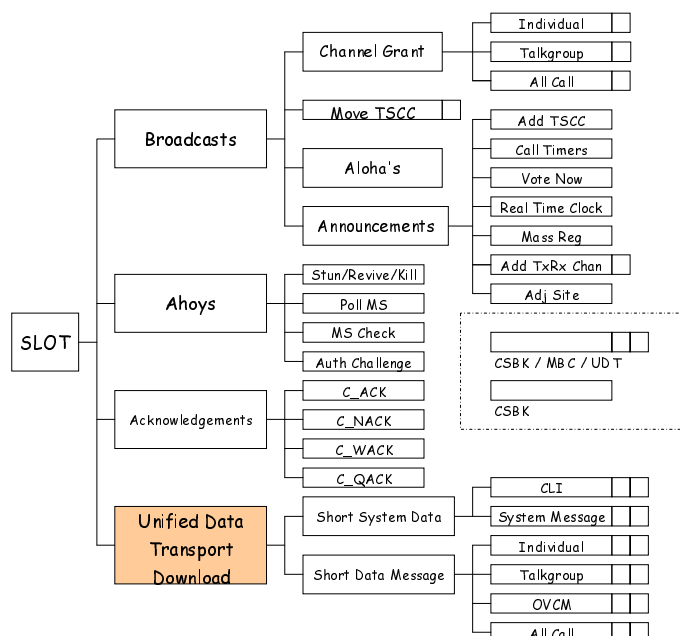

Figure 7.15

NOTE: UDT Headers are transmitted by both TS and MS.

Table 7.22: Unified Data Transport Download Header PDU content

Information element	Length	Remark
<b>Feature elements</b>		
<b>Elements defined in TS 102 361-1 [5]</b>		
G/I (IG)	1	0 <sub>2</sub> = Destination is an individual MS address 1 <sub>2</sub> = Destination is a Talkgroup address. Response not expected
A	1	0 <sub>2</sub> = Response not expected if Destination is an individual MS address 1 <sub>2</sub> = Response demanded if Destination is an individual MS address
Emergency	1	0 <sub>2</sub> = This PDU is not supporting an emergency priority call 1 <sub>2</sub> = This PDU is supporting an emergency priority call
UDT_Option_Flag	1	See clause 7.2.12.2
Format	4	0000 <sub>2</sub>
SAP	4	Service Access Point - 0000 <sub>2</sub> for UDT
UDT_Format	4	Format of the data following the UDT Header
Target_address or Gateway	24	
Source_address or Gateway	24	
Pad Nibble	5	
Reserved	1	0 <sub>2</sub>
Appended_Blocks(UAB)	2	Number of Blocks appended to this UDT Header 00 <sub>2</sub> = 1 Appended Data UDT block 01 <sub>2</sub> = 2 Appended Data UDT blocks 10 <sub>2</sub> = 3 Appended Data UDT blocks 11 <sub>2</sub> = 4 Appended Data UDT blocks
Supplementary_Flag(SF)	1	0 <sub>2</sub> = This UDT Header is carrying the data for a user initiated service (Short Data, Data Polling) 1 <sub>2</sub> = This UDT Header is carrying supplementary data, supporting another Tier III service.
Protect Flag (PF)	1	Reserved for Future Use
Opcode (UDTHD)	6	Shall be set to 01 1010 <sub>2</sub>
NOTE: Shaded rows are information elements that are defined in TS 102 361-1 [5].		

### 7.1.1.2 TSCC Inbound channel CSBKs/UDTs transmitted by MS

#### 7.1.1.2.1 Random Access Request (C\_RAND) PDU

Octet 0 and 1 of the Random Access CSBK (C\_RAND\_CSBK) PDU conform to the LC format structure as defined in figure 7.1 in TS 102 361-1 [5] of the standard with the CSBK0 replacing the FLC0. Octets 2 to 9 contain the Random Access Request specific information specified in table 7.23. Random Access Requests are sent by MS.

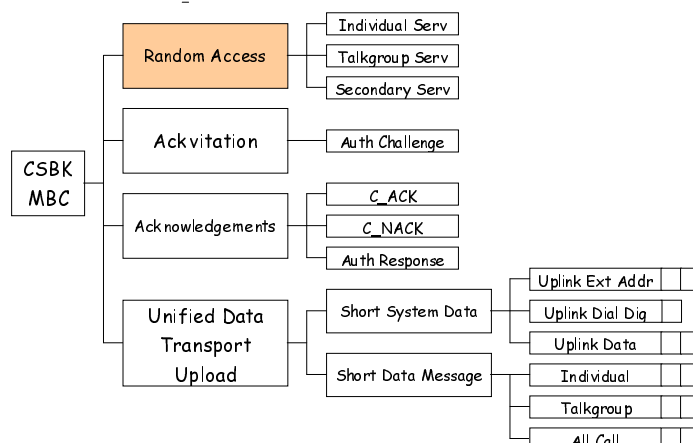

Figure 7.16

Table 7.23: Random Access Request PDU content

Information element	Length	Remark
<b>Message dependent elements</b>		
Last block (LB)	1	This bit shall be set to 1 <sub>2</sub>
Protect Flag (PF)	1	
<b>Feature elements</b>		
CSBK Opcode (CSBKO)	6	Shall be set to 01 1111 <sub>2</sub>
Manufacturers Feature ID	8	Shall be set to 0000 0000 <sub>2</sub>
Service_Options	7	
Proxy Flag	1	0 <sub>2</sub> - Number of Extended BCD digits for addressing through a gateway = 1 to 20 1 <sub>2</sub> - Number of Extended BCD digits for addressing through a gateway = 21 to 44
Appended_Supplementary_Data ALS Accept/Reject	2	Information Element depends on Service being supported
Appended_Short_Data	2	Number of appended CSBKs required to transport UDT short data
Service_Kind	4	Service requested
Target_address or Gateway	24	
Source_address	24	Address of the requesting MS

#### 7.1.1.2.2 C\_Ackvitation (C\_ACKVIT) CSBK PDU

Octet 0 and 1 of the C\_ACKVIT CSBK PDU conforms to the LC format structure as defined in figure 7.1 in TS 102 361-1 [5] of the standard with the CSBKO replacing the FLCO. Octets 2 to 9 contain the C\_Ackvitation specific information. The generic C\_Ackvitation PDU is illustrated in table 7.24. C\_Ackvitation PDUs are transmitted by MS.

The C\_Ackvitation PDU is transmitted by the MS as a single block CSBK.

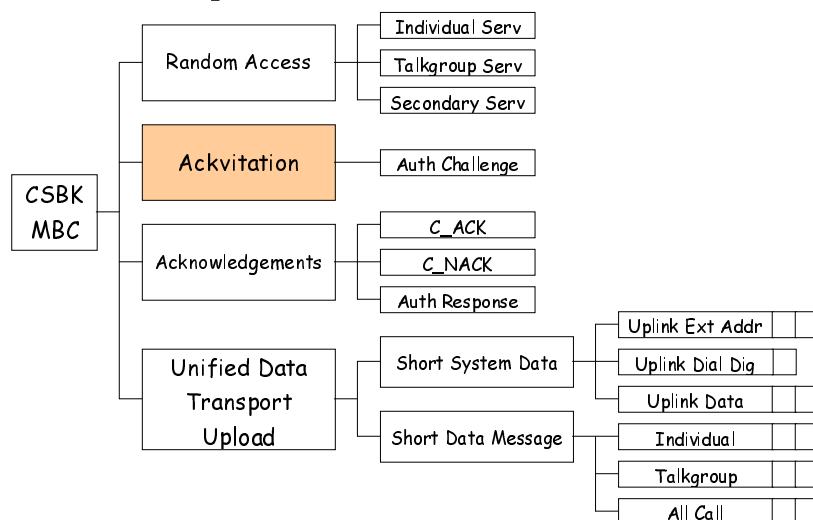

Figure 7.17



Table 7.24: C\_Ackvitation PDU content

Information element	Length	Remark
<b>Message dependent elements</b>		
Last block (LB)	1	This bit shall be set to 1 <sub>2</sub> for a single block CSBK or 0 <sub>2</sub> for a all but the last block of a multi-block CSBK
Protect Flag (PF)	1	
<b>Feature elements</b>		
CSBK Opcode (CSBKO)	6	Shall be set to 01 1110 <sub>2</sub>
Feature set ID (FID)	8	Shall be set to 0000 0000 <sub>2</sub>
Service_Options_Mirror	7	
Service_Kind_Flag	1	Meaning dependent on Service_Kind
Reserved	2	00 <sub>2</sub>
Appended_Blocks (UAB)	2	For a demand to the TS to send a multi-block CSBK, the number of appended data blocks
Service_Kind	4	Service for which this C_Ackvitation is supporting
Target address	24	Authentication Challenge value
Source Address	24	Individual address of MS sending the C_Ackvitation

### 7.1.1.2.3 C\_Acknowledge (C\_ACKU) MS Response CSBK PDU

Octet 0 and 1 of the Acknowledge Response CSBK PDU conforms to the LC format structure as defined in figure 7.1 in TS 102 361-1 [5] of the standard with the CSBKO replacing the FLCO. Octets 2 to 9 contain the Acknowledge Response specific information. The generic Acknowledge Response PDU is illustrated in table 7.25.

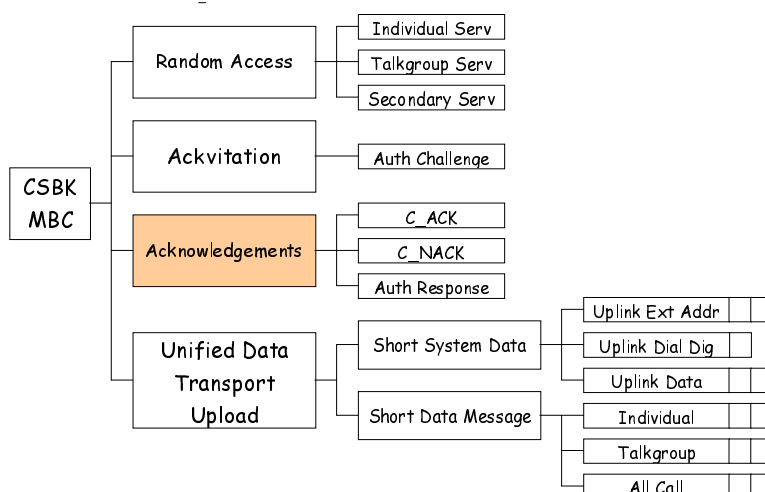

Figure 7.18

NOTE: Acknowledgement Responses are transmitted by both TS and MS.

Table 7.25: MS Acknowledge Response PDU content

Information element	Length	Remark
<b>Message dependent elements</b>		
Last block (LB)	1	This bit shall be set to 1 <sub>2</sub>
Protect Flag (PF)	1	
<b>Feature elements</b>		
CSBK Opcode (CSBKO)	6	Shall be set to 10 0001 <sub>2</sub>
Feature set ID (FID)	8	Shall be set to 0000 0000 <sub>2</sub>
Response_Info	7	Supplementary response information
Reason Code	8	
Reserved	1	This bit shall be set to 0 <sub>2</sub>
Target address or Authentication	24	The Source Address from the TS PDU for which this acknowledgement is being transmitted or authentication challenge response if this acknowledgement is being transmitted as part of authentication challenge
Additional Information (Source Address)	24	MS individual address that is transmitting the acknowledgement

Acknowledge Response PDUs are arranged into classes:

C\_ACKU - Positive Acknowledgement.

C\_NACKU - Negative Acknowledgement.

#### 7.1.1.2.4 Unified Data Transport Inbound channel Header (C\_UDTHU) UDT PDU

C\_UDT PDUs are sent by TS and MS. This PDU is a multi-block UDT conforming to the format specified in table 7.26. The number of UDT Appended data blocks is indicated by the Appended Blocks (UAB) information element.

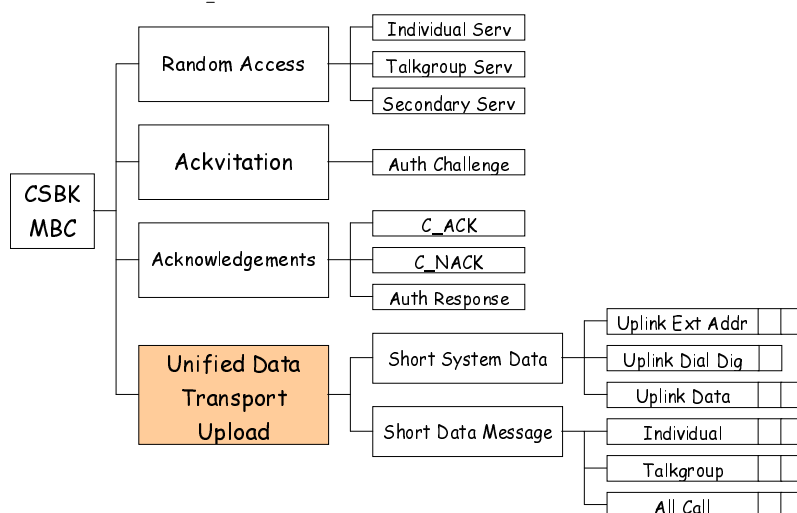

Figure 7.19

NOTE: UDT Headers are transmitted by both TS and MS.

Table 7.26: Unified Data Transport Inbound channel Header PDU content

Information element	Length	Remark
<b>Feature elements</b>		
<b>Elements defined in TS 102 361-1 [5]</b>		
G/I (IG)	1	0 <sub>2</sub> = Destination is an individual MS address 1 <sub>2</sub> = Destination is a Talkgroup address.
A	1	0 <sub>2</sub> = Response not expected if Destination is an individual MS address 1 <sub>2</sub> = Response demanded if Destination is an individual MS address
Reserved	1	0 <sub>2</sub>
UDT_DIV	1	0 <sub>2</sub> = This UDT is not carrying Call Diversion destination information 1 <sub>2</sub> = This UDT is carrying Call Diversion destination information
Format	4	0000 <sub>2</sub>
SAP	4	Service Access Point - 0000 <sub>2</sub> for UDT
UDT_Format	4	Format of the data following the UDT Header
Target_address or Gateway	24	
Source_address or Gateway	24	
Pad Nibble	5	
Reserved	1	
Appended_Blocks(UAB)	2	Number of Blocks appended to this UDT Header 00 <sub>2</sub> = 1 Appended Data UDT block 01 <sub>2</sub> = 2 Appended Data UDT blocks 10 <sub>2</sub> = 3 Appended Data UDT blocks 11 <sub>2</sub> = 4 Appended Data UDT blocks
Supplementary_Flag(SF)	1	0 <sub>2</sub> = This UDT Header is carrying the data for a user initiated service (Short Data, Data Polling) 1 <sub>2</sub> = This UDT Header is carrying supplementary data, supporting another Tier III service.
Protect Flag (PF)	1	Reserved for Future Use
Opcode (UDTHU)	6	Shall be set to 01 1011 <sub>2</sub>
NOTE: Shaded rows are information elements that are defined in TS 102 361-1 [5].		

### 7.1.1.3 Outbound channel CSBKs transmitted on a Payload Channel by a TS

#### 7.1.1.3.1 Channel Grant (P\_GRANT) CSBK/MBC PDU

Channel Grant PDUs transmitted on the payload channel conform to the same structure as channel grant PDUs transmitted on the TSCC. When transmitting such a PDU on the payload channel, the TS shall retain all Information Elements to the value from the TSCC channel grant PDU except the logical channel number (and absolute frequency if the channel grant PDU has an appended CSBK block) (see table 7.27).

The Payload Channel Grant PDU is transmitted by the TSCC either as a single block CSBK or a Multi Block Control (MBC). For the Physical Channel Number Information Element:

- a) If the value = 0000 0000 0000<sub>2</sub> the Physical Channel number is invalid.
- b) If the value = 0000 0000 0001<sub>2</sub> to 1111 1111 1110<sub>2</sub>, the Physical Channel number represent a logical channel number for the physical transmitter and receiver frequency. The Private Data Channel Grant PDU is transmitted by the TSCC as a single block CSBK.
- c) If the value = 1111 1111 1111<sub>2</sub>, the Physical Channel number defines a multi-block CSBK where the absolute transmitter and receiver frequency is defined in a second block concatenated to this block (defined in clause 7.1.1.1.2).

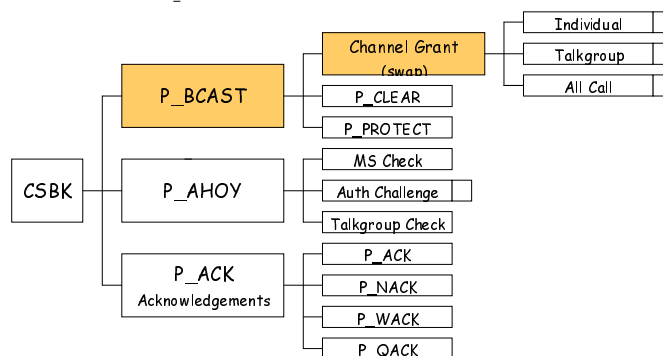

Figure 7.20

Table 7.27: Payload Channel Grant PDU Content

Information element	Length	Remark
<b>Message dependent elements</b>		
Last block (LB)	1	This bit shall be set to 1 <sub>2</sub> for a single block CSBK or 0 <sub>2</sub> if this is a MBC header
Protect Flag (PF)	1	
<b>Feature elements</b>		
CSBK Opcode (CSBKO)	6	Shall be set to the value from the Channel Grant sent by the TSCC that directed this MS to the traffic channel
Feature set ID (FID)	8	Shall be set to 0000 0000 <sub>2</sub>
Logical Physical Channel Number	12	Payload Channel for the Call or an indicator that the absolute Tx & Rx frequency is specified in an appended CSBK block
Logical Channel Number	1	0 <sub>2</sub> - TDMA channel 1 1 <sub>2</sub> - TDMA channel 2
OVCN or Packet Mode Emergency Offset	3	OVCN (or Packet Mode in case of data), Emergency and Offset (offset or aligned timing) from the TSCC that directed this MS to the traffic channel
Destination_address	24	Called party Individual MS Address, Gateway or Talkgroup
Source_address	24	Calling Party or Gateway

### 7.1.1.3.2 Clear (P\_CLEAR) CSBK PDU

Octet 0 and 1 of the P\_CLEAR CSBK PDU conforms to the LC format structure as defined in figure 7.1 in TS 102 361-1 [5] of the standard with the CSBKO replacing the FLCO. Octets 2 to 9 contain the P\_Clear specific information illustrated in table 7.28. P\_Clear is transmitted by the TS on a payload channel only and does not solicit a response.

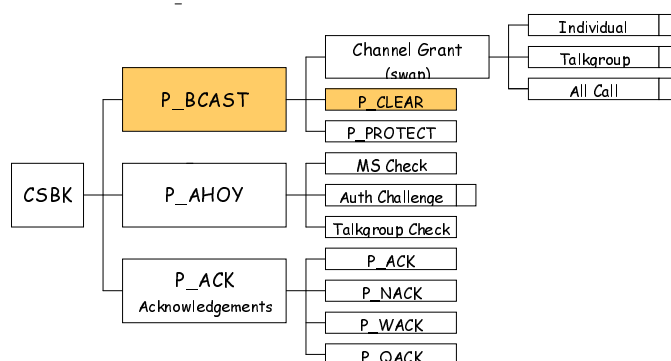

Figure 7.21

Table 7.28: P\_Clear PDU Content

Information element	Length	Remark
<b>Message dependent elements</b>		
Last block (LB)	1	This bit shall be set to 1 <sub>2</sub>
Protect Flag (PF)	1	
<b>Feature elements</b>		
CSBK Opcode (CSBKO)	6	Shall be set to 10 1110 <sub>2</sub>
Feature set ID (FID)	8	Shall be set to 0000 0000 <sub>2</sub>
Logical Physical Channel Number	12	Channel to which the addressed party(s) shall move or an indicator that the absolute Tx and Rx frequency is specified in an appended CSBK block
Reserved	3	000 <sub>2</sub>
IG	1	0 <sub>2</sub> - The Target Address is a MS ID
		1 <sub>2</sub> - The Target address is a talkgroup
Target Address	24	Target MS ID, Talkgroup or ALLMSI (see note)
Source Address	24	TSI
NOTE: If the target address is ALLMSI then IG=0 <sub>2</sub> .		

The P\_Clear PDU is transmitted by the TS either as a single block CSBK or a Multi Block Control (MBC). For the Physical Channel Number Information Element:

- If the value = 0000 0000 0000<sub>2</sub> the applicable MS(s) shall move to the channel number of the control channel on which the MS was last confirmed.
- Physical Channel number is invalid. The Clear PDU is transmitted by the TS as a single block CSBK.
- If the value = 0000 0000 0001<sub>2</sub> to 1111 1111 1110<sub>2</sub>, the Physical Channel number represent a logical channel number for the physical transmitter and receiver frequency. The Clear PDU is transmitted by the TS as a single block CSBK.
- If the value = 1111 1111 1111<sub>2</sub>, the Physical Channel number defines a multi-block CSBK where the absolute transmitter and receiver frequency is defined in a second block concatenated to this block (defined in clause 7.1.1.1.2).

In most Tier III networks the P\_Clear PDU is used to clear all MS and talkgroups from a traffic channel so the traffic channel may be re-allocated for a new call. To effect this behaviour the Target Address is set to ALLMSI.

### 7.1.1.3.3 Protect (P\_PROTECT) CSBK PDU

Octet 0 and 1 of the P\_Protect CSBK PDU conforms to the LC format structure as defined in figure 7.1 in TS 102 361-1 [5] of the standard with the CSBKO replacing the FLCO. Octets 2 to 9 contain the P\_Protect specific information illustrated in table 7.29. P\_Protect is transmitted by the TS on a payload channel only and does not solicit a response. The P\_Protect PDU is transmitted by the TS as a single block CSBK.

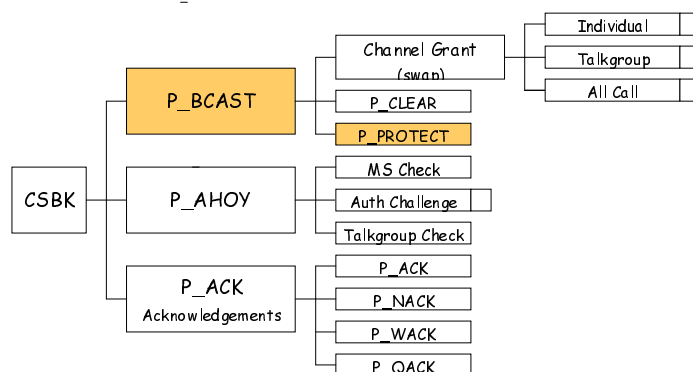

Figure 7.22

Table 7.29: P\_Protect PDU content

Information element	Length	Remark
<b>Message dependent elements</b>		
Last block (LB)	1	This bit shall be set to 1 <sub>2</sub>
Protect Flag (PF)	1	
<b>Feature elements</b>		
CSBK Opcode (CSBKO)	6	Shall be set to 10 1111 <sub>2</sub>
Feature set ID (FID)	8	Shall be set to 0000 0000 <sub>2</sub>
Reserved	12	0000 0000 0000 <sub>2</sub>
Protect_Kind	3	
IG	1	
Target Address	24	Target Address from the Channel Grant
Source Address	24	Source Address from the Channel Grant

#### 7.1.1.3.4 Ahoy (P\_AHOY) CSBK PDU

Octet 0 and 1 of the AHOY CSBK PDU conforms to the LC format structure as defined in figure 7.1 in TS 102 361-1 [5] of the standard with the CSBKO replacing the FLCO. Octets 2 to 9 contain the P\_AHOY specific information illustrated in table 7.20. The P\_AHOY is transmitted by the TS on a payload channel and if addressed to a talkgroup does not solicit a response.

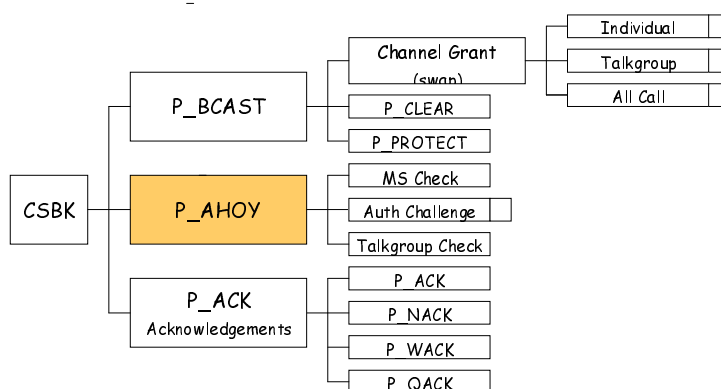

Figure 7.23

##### 7.1.1.3.4.1 MS Presence Check

The TS may send a MS Presence Check P\_AHOY on the payload channel to check if an individually addressed MS is present on the payload channel.

##### 7.1.1.3.4.2 MS Authentication Check

The TS may send a MS Authentication Check P\_AHOY on the payload channel to challenge an MS.

##### 7.1.1.3.4.3 Talkgroup Presence Check

The TS may send a Talkgroup Presence Check P\_AHOY on the payload channel to check if at least one talkgroup is present on the payload channel.

##### 7.1.1.3.5 P\_Acknowledgement response

Acknowledgement PDUs transmitted on the payload channel conform to the same structure as acknowledgement PDUs transmitted on the TSCC.

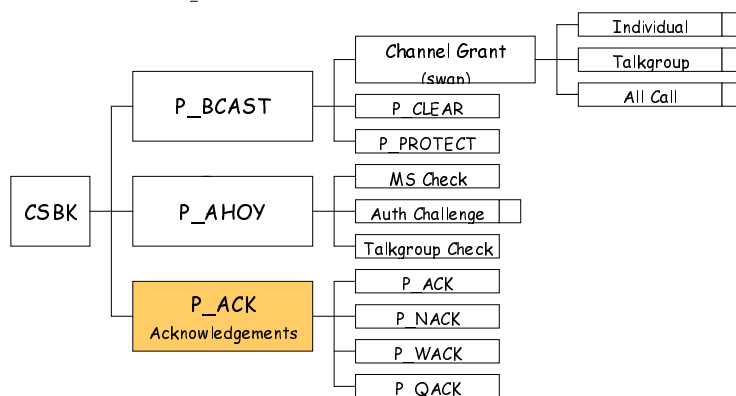

Figure 7.24

### 7.1.1.4 Inbound channel CSBKs transmitted on a Payload Channel by MS(s)

#### 7.1.1.4.1 Random Access Request PDU

Random Access PDUs transmitted on the payload channel conform to the same structure as Random Access PDUs transmitted on the TSCC. However the only random access Service\_Kind permitted on the payload channel shall be to request an include service.

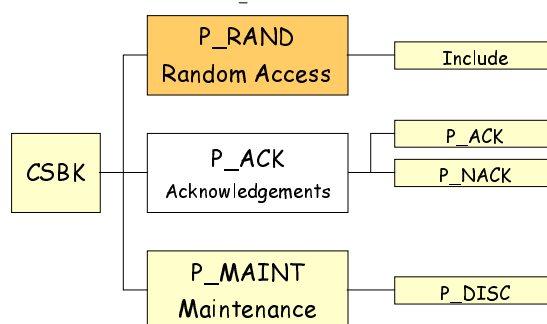

Figure 7.25

#### 7.1.1.4.2 P\_ACK Acknowledgements

Acknowledgement PDUs transmitted on the payload channel conform to the same structure as acknowledgement PDUs transmitted on the TSCC.

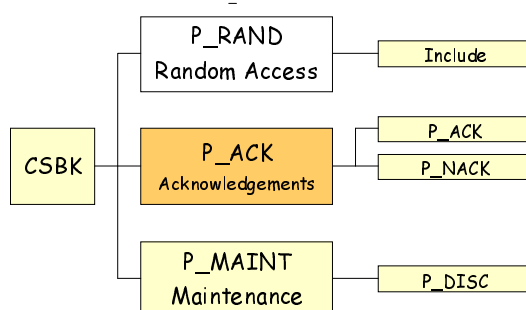

Figure 7.26

### 7.1.1.4.3 P\_MAINT Maintenance PDUs

Octet 0 and 1 of the P\_MAINT CSBK PDU conforms to the LC format structure as defined in figure 7.1 in TS 102 361-1 [5] of the standard with the CSBKO replacing the FLCO. Octets 2 to 9 contain the P\_MAINT specific information illustrated in table 7.30. P\_MAINT is transmitted by MS on a payload channel only. The P\_MAINT PDU is transmitted by MS as a single block CSBK.

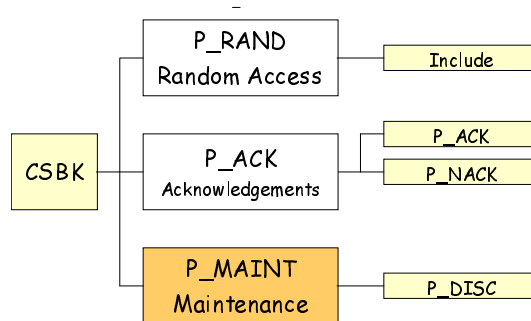

Figure 7.27

Table 7.30: P\_MAINT PDU content

Information element	Length	Remark
<b>Message dependent elements</b>		
Last block (LB)	1	This bit shall be set to 1 <sub>2</sub>
Protect Flag (PF)	1	
<b>Feature elements</b>		
CSBK Opcode (CSBKO)	6	Shall be set to 10 1010 <sub>2</sub>
Feature set ID (FID)	8	Shall be set to 0000 0000 <sub>2</sub>
Reserved	12	
Maint Kind	3	
Reserved	1	
Target Address	24	TSI
Source Address	24	MS Address

## 7.1.2 Short Link Control PDUs

### 7.1.2.1 System Parameters

Bits 0 to 3 of Octet 0 of the System Parameters (SYS\_Parms) Short LC PDU conform to the Short LC format structure as defined in figure 7.2 of clause 7.1 in TS 102 361-1 [5]. Octets 1 to 3 contain the System Parameters specific information. The SYS\_Parms PDU is illustrated in table 7.31.



**Table 7.31: SYS\_Parms PDU Content**

Information element	Length	Value	Remark
<b>Elements</b>			
Short LC Opcode (SLCO)	4	0010 <sub>2</sub>	
MODEL	2	00 <sub>2</sub>	Tiny Network Model
		01 <sub>2</sub>	Small Network Model
		10 <sub>2</sub>	Large Network Model
		11 <sub>2</sub>	Huge Network Model
NET SITE	12		Network and Site Definition
Reg	1	0 <sub>2</sub>	This TSCC does not require the MS to register before becoming active
		1 <sub>2</sub>	This TSCC requires the MS to register before becoming active
Common_Slot_Counter	9		Common Slot Counter

## 7.2 Layer 3 information element coding

The following clauses contain descriptions of the information elements contained within layer 3 PDUs, and provide a description of what the elements represent in relation to their bit representation. The structure of the tables is as follows:

- the information element column gives the name of the element;
- the element length column defines the length of the element in bits;
- the value column denotes fixed values or a range of values;
- the remarks column defines the meaning of the information element against each of its bit represented values.

### 7.2.1 Mask

The Mask information element has a length of 5 bits and is illustrated in table 7.32.

**Table 7.32: Mask**

Information element	Length	Value	Remark
Mask	5	0 to 24	Value in the range 0 to 24 (decimal)

### 7.2.2 Service Function

The Service Type information element has a length of 2 bits and is illustrated in table 7.33.

**Table 7.33: Service Function**

Information element	Length	Value	Remark
Service Function	2	00 <sub>2</sub>	Random Access invited for all Services
		01 <sub>2</sub>	Random Access Invited for Services that require a payload channel Random Access Invited for registration requests
		10 <sub>2</sub>	Random Access Invited for Services that do not require a payload channel Random Access Invited for registration requests
		11 <sub>2</sub>	Random Access invited for random access registration requests only

### 7.2.3 NRand\_Wait

The Nrand\_Wait information element has a length of 4 bits and is illustrated in table 7.34. The TSCC shall specify, using NRand\_Wait, the delay (in TDMA-frames) a MS shall wait before deciding to retransmit and choose another slot from a new random-access-frame.

**Table 7.34: NRand\_Wait**

Information element	Length	Value	Remark
NRand_Wait	4	0 to 15	TSCC response to a Random Access Request 0 = response in the next TDMA-frame 1 - MS shall wait for 1 TDMA frame 2 - MS shall wait for 2 TDMA frames 3 - MS shall wait for 3 TDMA frames 4 - MS shall wait for 4 TDMA frames 5 - MS shall wait for 5 TDMA frames 6 - MS shall wait for 6 TDMA frames 7 - MS shall wait for 7 TDMA frames 8 - MS shall wait for 8 TDMA frame 9 - MS shall wait for 9 TDMA frames 10 - MS shall wait for 10 TDMA frames 11 - MS shall wait for 11 TDMA frames 12 - MS shall wait for 12 TDMA frames 13 - MS shall wait for 13 TDMA frames 14 - MS shall wait for 15 TDMA frames 15 - MS shall wait for 24 TDMA frames

### 7.2.4 Reg

The Reg information element has a length of 1 bit and is illustrated in table 7.35.

**Table 7.35: Reg**

Information element	Length	Value	Remark
Reg	1	0 <sub>2</sub>	MSs are not required to register
		1 <sub>2</sub>	MSs are required to register

### 7.2.5 Backoff

The Backoff information element has a length of 4 bits and is illustrated in table 7.36.

**Table 7.36: Backoff Number**

Information element	Length	Value	Remark
Backoff	4	0	0 - Reserved
		1	Backoff TDMA Frame length = 1
		2	Backoff TDMA Frame length = 2
		3	Backoff TDMA Frame length = 3
		4	Backoff TDMA Frame length = 4
		5	Backoff TDMA Frame length = 5
		6	Backoff TDMA Frame length = 8
		7	Backoff TDMA Frame length = 11
		8	Backoff TDMA Frame length = 15
		9	Backoff TDMA Frame length = 20
		10	Backoff TDMA Frame length = 26
		11	Backoff TDMA Frame length = 33
		12	Backoff TDMA Frame length = 41
		13	Backoff TDMA Frame length = 50
		14	Backoff TDMA Frame length = 70
15	Backoff TDMA Frame length = 100		

## 7.2.6 System Identity Code

The System Identity Code information element has a length of 16 bits and is illustrated in table 7.37.

**Table 7.37: System Identity Code**

Information element	Length	Value	Remark
System Identity Code C_SYSCode	16	value	System identity Code transmitted on the TSCC

## 7.2.7 Response\_Info

The Response\_Info information element contains supplementary information in acknowledgement PDUs. It has a length of 7 bits and is illustrated in table 7.38.

**Table 7.38: Response\_Info**

Information element	Length	Alias/value	Remark
Acknowledgement Reason Code = Reg_Accepted (0110 0010 <sub>2</sub> )			
Response_Info	7	PowerSAve_Offset	Acknowledgement to a random access registration request that invokes power save (see clause 6.4.7). The target address is a MS individual ID
Acknowledgement Reason Code = Accepted for the Status Polling Service (0110 0011 <sub>2</sub> )			
Status	7	Status value	Outbound acknowledgement The target address is an individual MS
Acknowledgement Reason Code = Accepted for the Status Polling Service (0100 0111 <sub>2</sub> )			
Status	7	Status value	Inbound acknowledgement The target address is an individual MS
All other acknowledgement Reason Codes			
IG	1	0 <sub>2</sub>	The Target address is an MS individual ID or Gateway
		1 <sub>2</sub>	The Target address is a talkgroup
Response_Check	6	Value	The six least significant bits from the NET + SITE elements of the C_SYSCode transmitted by the TSCC (see note)
NOTE: The bits are 8, 7, 6, 5, 4 and 3 illustrated in figure 6.19.			

## 7.2.8 Reason

The Reason information element has a length of 8 bits and is illustrated in tables 7.39 to 7.42. Separate tables are illustrated for the classifications C\_ACK, C\_NACK, C\_QACK, C\_WACK.

The Reason bits are set out as t t d a a a a a.

tt - ACK type, 00<sub>2</sub> = NACK; 01<sub>2</sub> = ACK; 10<sub>2</sub> = QACK; 11<sub>2</sub> = WACK.

d - direction, 1<sub>2</sub> = TS to MS; 0<sub>2</sub> = MS to TS, or transmitted by a TS to mirror the acknowledgement sent by a MS to other applicable parties.

a a a a a - acknowledgement reason.

There are instances whereby the Reason Code for an acknowledgement from a MS shall be retransmitted by the TS. In this case the reason code from the MS is mirrored exactly by the TS. Such an acknowledgement is described in the present document as a Mirrored\_Reason.

### 7.2.8.1 Acknowledgements C\_ACK

Table 7.39 illustrates positive final acknowledgements.

Table 7.39: Answer Response C\_ACK

Information element	Length	Value	Alias	Remark
		Acknowledgement Transmitted by a TS Message Accepted by the MS		
Reason	8	0110 0000 <sub>2</sub>	Message_Accepted	Message accepted by TS - Proceed
		0110 0001 <sub>2</sub>	Store_Forward	Call is placed in store and forward buffer for onward transmission when the called MS registers
		0110 0010 <sub>2</sub>	Reg_Accepted	Request from MS to register has been accepted
		0110 0011 <sub>2</sub>	Authentication Response	TS Response to a successful Authentication Challenge
		Acknowledgement Transmitted by a MS Message Accepted by the TS (may be forwarded by the TS)		
		0100 0100 <sub>2</sub>	MS_Accepted	Message accepted by MS (or mirrored by the TS)
		0100 0101 <sub>2</sub>	CallBack	Called MS is indicating to the TS that it will call back later (or mirrored by the TS)
		0100 0110 <sub>2</sub>	MS_ALERTING	MS alerting but not yet RFC (or mirrored by the TS)
		0100 0111 <sub>2</sub>	Accepted for the Status Polling Service	Message accepted for the Status Poll Service. Response_Info contains the Status value
		0100 1000 <sub>2</sub>	Authentication Response	TS Response to a successful Authentication Challenge

There are some PDU exchanges between the MS and TSCC whereby an acknowledgement transmitted by an MS is retransmitted by the TS using an identical reason code. This acknowledgement is a mirrored reason code and is identified as mirrored in the detailed call procedures.

### 7.2.8.2 Acknowledgements C\_NACK

Table 7.40 illustrates rejection final acknowledgements.

a) For Messages/Services rejected by the network:

- Not Supported (0010 0000<sub>2</sub>)

The MS is registered with the network and has made a random access request for a service that the network does not support.

- Perm\_User\_Refused (0010 0001<sub>2</sub>)

The MS is registered with the network and has made a random access request for a service that the network does not permit for this user.

- Temp\_User\_Refused (0010 0011<sub>2</sub>)

The MS is registered with the network and has made a random access request for a service that the network supports but for some reason the network cannot connect call at this time. (An example may be that the network offers PSTN access but the connection between the system and the PSTN is malfunctioning).

- NoregMSaway\_Refused (0010 0100<sub>2</sub>)

The MS is registered with the network and has made a random access request for a service that the network supports. The called party is also valid on the network but is not registered at this time. (The present document supports deregistration when an MS is switched off).

- MSaway\_Refused (0010 0101<sub>2</sub>)

The MS is registered with the network and has made a random access request for a service that the network supports. The called party is also valid on the network and is registered. However when the network has completed a called party radio check the called MS did not respond and was assumed to be not in radio contact.

- Div\_Cause\_Fail (0010 0110<sub>2</sub>)

An MS has polled another MS for UDT short data but the polled MS has diverted its calls so the poll cannot proceed (see clause 6.6.5.1.1).

- SYSbusy\_Refused (0010 0111<sub>2</sub>)

The MS is registered with the network and has made a random access request for a service that the network supports. The request has been refused because the network is experiencing such a high rate of congestion that the service cannot be provided at this time.

- SYS\_NotReady (0010 1000<sub>2</sub>)

The MS is registered with the network and has made a random access request for a service. The request has been refused because the network is not ready at this time. The system may be under maintenance or under construction.

- Call\_Cancel\_Refused (0010 1001<sub>2</sub>)

The MS is registered with the network and has made a random access request for a service. The system has sent a C\_QACK or C\_WACK acknowledgement. Following this acknowledgement the calling MS has sent a further random access request to cancel the call. The network cannot cancel the call and sends this PDU to inform the calling party that the call cannot be cancelled.

- Reg\_Refused (0010 1010<sub>2</sub>)

See clause 6.4.4.

- Reg\_Denied (0010 1011<sub>2</sub>)

See clause 6.4.4.

- IP\_Connection\_failed (0010 1100<sub>2</sub>)

See clause 6.4.11.1.4 and 6.4.11.2.

- MS\_Not\_Registered (0010 1101<sub>2</sub>)

This system demands that a MS registers with the TSCC before attempting any service request. The MS has violated the system requirement and has therefore been refused service.

- Called\_Party\_Busy (0010 1101<sub>2</sub>)

The MS is registered with the network and has made a random access request for a service. The called party is busy. The system does not wish to queue the call.

- Called\_Group\_Not\_Allowed (0010 1111<sub>2</sub>)

The MS is registered with the network and has made a random access request for a talkgroup service. The talkgroup ID is not allowed by the TSCC.

- Refused\_Reason\_Unknown (00111111<sub>2</sub>)

The MS is registered with the network and has made a random access request for a service. The call has been refused but the reason is not known.

## b) For Messages/Services rejected by MS:

- MSNot\_Supported (0000 0000<sub>2</sub>)

The TSCC has send a PDU to the MS that demands a response. The particular service that is being call for is not supported by the MS.

- LineNot\_Supported (0001 0001<sub>2</sub>)

The TSCC has attempted a transaction that requires the MS to have additional equipment available. If that equipment is not installed this is an appropriate response.

- StackFull\_Refused (0001 0010<sub>2</sub>)

The TSCC has attempted to send some information that the MS shall store. The MS store is full and the MS cannot therefore accept the information. For example a MS may hold the address of calling parties where that call has not been answered and that called part stores the calling party address. If the store is full the Stack\_Full\_Refused is an appropriate response.

- EuiBusy\_Refused (0001 0011<sub>2</sub>)

The TSCC has attempted a transaction that requires the MS to have additional equipment available and ready. If that equipment is busy this is an appropriate response.

- Recipient\_Refused (0001 0100<sub>2</sub>)

The TSCC has attempted a call or transaction that the called party MS does not wish to accept.

- Custom\_Refused (0001 0101<sub>2</sub>)

This response is for any manufacturer specific reason for refusal of a call or transaction but excluding registration procedures.

- Refused\_Reason\_Unknown (0001 1111<sub>2</sub>)

The PDU to the MS has been refused but the reason is unknown.

**Table 7.40: Answer Response C\_NACK**

Information element	Length	Value	Mnemonic	Remark
		Message/Service rejected by network (TS)		
Reason	8	0010 0000 <sub>2</sub>	Not_Supported	Network does not support this service
		0010 0001 <sub>2</sub>	Perm_User_Refused	Request refused because service has not been authorized for this user (permanent) (Meaning of permanent is manufacturer specific)
		0010 0010 <sub>2</sub>	Temp_User_Refused	Request refused because service is not currently authorized for this user (temporary) (Meaning of temporary is manufacturer specific)
		0010 0011 <sub>2</sub>	Transient_Sys_Refused	Request refused because the service is not available to this network at this time
		0010 0100 <sub>2</sub>	NoregMSaway_Refused	Request refused because called party is not in radio contact (and is not registered with the network)
		0010 0101 <sub>2</sub>	MSaway_Refused	Request refused because called party is not in radio contact (but is registered with the network)
		0010 0110 <sub>2</sub>	Div_Cause_Fail	Call cannot be processed because the MS has diverted its calls
		0010 0111 <sub>2</sub>	SYSbusy_Refused	Request refused because the network is experiencing congestion (Network Overload)

	0010 1000 <sub>2</sub>	SYS_NotReady	Request refused because the network is not ready (try later)
	0010 1001 <sub>2</sub>	Call_Cancel_Refused	Request to <i>cancel</i> a call has been refused i.e. the call may still mature
	0010 1010 <sub>2</sub>	Reg_Refused	Request from a MS to register has been refused
	0010 1011 <sub>2</sub>	Reg_Denied	Request from a MS to register has been denied
	0010 1100 <sub>2</sub>	IP_Connection_failed	Request from a MS to inform IP connection advice failed
	0010 1101 <sub>2</sub>	MS_Not_Registered	This system requires MS to be registered before accepting a user service request. The MS is not registered
	0010 1110 <sub>2</sub>	Called_Party_Busy	The called party is busy and the network does not wish to queue the call
	0010 1111 <sub>2</sub>	Called_Group_Not_Allowed	The talkgroup ID is not allowed by the TSCC
	0011 1111 <sub>2</sub>	Refused_Reason_Unknown	The request as been refused but the reason is unknown
	<b>Message/Service rejected by MS (may be forwarded by TS)</b>		
	0000 0000 <sub>2</sub>	MSNot_Supported	MS does not support this service or feature
	0001 0001 <sub>2</sub>	LineNot_Supported	Request refused because service is not supported by the called party (Line)
	0001 0010 <sub>2</sub>	StackFull_Refused	Request refused because the called party's internal call stack is full and is not employing a FIFO
	0001 0011 <sub>2</sub>	EquipBusy_Refused	Request refused because called party ancillary equipment is busy
	0001 0100 <sub>2</sub>	Recipient_Refused	Request refused by called party user (like in FOACSU)
	0001 0101 <sub>2</sub>	Custom_Refused	Request refused due to custom-defined reason
	0001 1111 <sub>2</sub>	Refused_Reason_Unknown	The PDU to the MS has been refused but the reason is unknown

Table 7.41: Answer Response C\_QACK

Information element	Length	Value	Alias	Remark
<b>Acknowledgement Transmitted by a TS</b>				
Reason	8	1010 0000 <sub>2</sub>	Queued-for-resource (e.g. payload channel)	Message accepted by TS - more signalling to follow
		1010 0001 <sub>2</sub>	Queued-for-busy	Called party is engaged in another call

Table 7.42: Answer Response C\_WACK

Information element	Length	Value	Alias	Remark
<b>Acknowledgement Transmitted by a TS</b>				
Reason	8	1110 0000 <sub>2</sub>	Wait	Message accepted by TS - more signalling to follow

## 7.2.9 Digits

The Digits information element represents dialled digits coded as table 7.43.

Table 7.43: Digits

Information element	Length	Value	Alias	Remark
Digits	4	0000 <sub>2</sub>	Digit '0'	
		0001 <sub>2</sub>	Digit '1'	
		0010 <sub>2</sub>	Digit '2'	
		0011 <sub>2</sub>	Digit '3'	
		0100 <sub>2</sub>	Digit '4'	
		0101 <sub>2</sub>	Digit '5'	
		0110 <sub>2</sub>	Digit '6'	
		0111 <sub>2</sub>	Digit '7'	
		1000 <sub>2</sub>	Digit '8'	
		1001 <sub>2</sub>	Digit '9'	
		1010 <sub>2</sub>	Digit '*'	* character
		1011 <sub>2</sub>	Digit '#'	# character
		1100 <sub>2</sub>	Reserved	
		1101 <sub>2</sub>	Reserved	
		1110 <sub>2</sub>	Reserved	
1111 <sub>2</sub>	Digit 'NULL'			

### 7.2.10 Active\_Connection

This information element specifies if the TS has an active network connection with the rest of the network, i.e. communication with other radio sites is possible.

Table 7.44: Active\_Connection

Information element	Length	Value	Alias	Remark
Active_Connection	1	0 <sub>2</sub>		0 <sub>2</sub> - The TS does not have a connection with the network
		1 <sub>2</sub>		1 <sub>2</sub> - The TS has a connection with the network

### 7.2.11 Packet Mode

The Packet Mode information element has a length of 1 bit and is illustrated in table 7.45.

Table 7.45: Packet Mode

Information element	Length	Value	Alias	Remark
Packet Mode	1	0 <sub>2</sub>		0 <sub>2</sub> - Payload Channel uses 2:1 mode
		1 <sub>2</sub>		1 <sub>2</sub> - Payload Channel uses 1:1 mode

### 7.2.12 Service\_Kind

The Service\_Kind information element has a length of 4 bits and is illustrated in table 7.46.



Table 7.46: Service\_Kind information element

Information element	Length	Value	Remark
Service_Kind	4	0000 <sub>2</sub>	Individual Voice Call Service (Include Voice Individual Call Service if sent on a payload channel)
		0001 <sub>2</sub>	Talkgroup Voice Call Service (Include Voice Talkgroup Call Service if sent on a payload channel)
		0010 <sub>2</sub>	Individual Packet Data Call Service
		0011 <sub>2</sub>	Packet Data Call Service to a talkgroup
		0100 <sub>2</sub>	Individual Short Data Call Service
		0101 <sub>2</sub>	Talkgroup Short Data Call Service
		0110 <sub>2</sub>	Short Data Polling Service
		0111 <sub>2</sub>	Status Transport Service
		1000 <sub>2</sub>	Call Diversion Service
		1001 <sub>2</sub>	Call Answer Service
		1010 <sub>2</sub> to 1100 <sub>2</sub>	Reserved
		1101 <sub>2</sub>	Supplementary Service
		1110 <sub>2</sub>	Registration/Authentication Service (and deregistration)/MS Radio Check
		1111 <sub>2</sub>	Cancel Call Service

## 7.2.12.1 Service\_Kind\_Flag

The Service\_Kind\_Flag information element has a length of 1 bit and is illustrated in table 7.47. The meaning of Service\_Kind\_Flag supports the Service\_Kind information element. The meaning of the Service\_Kind\_Flag depends on the message containing this information element.

Table 7.47: Service\_Kind\_Flag information element

Service_Kind	Message	Service_Kind_Flag_Value	Remark
<b>TSCC Channel</b>			
0000 <sub>2</sub>	C_AHOY Voice Service Individual Radio Check	0 <sub>2</sub>	Check if called MS is in radio contact and can accept this call immediately. (OACSU)
		1 <sub>2</sub>	checks whether called MS is ready to accept speech or data call. (FOACSU)
0001 <sub>2</sub>	C_AHOY Voice Service Talkgroup Radio Check	0 <sub>2</sub>	Check if at least one member of the called talkgroup is in radio contact
0010 <sub>2</sub>	C_AHOY Packet Data individual radio check	0 <sub>2</sub>	Check if called MS is in radio contact
0011 <sub>2</sub>	C_AHOY Packet Data talkgroup radio check	0 <sub>2</sub>	Check if at least one member of the called talkgroup is in radio contact
0100 <sub>2</sub>	Individual Short Data Call Service	0 <sub>2</sub>	Not Applicable
0101 <sub>2</sub>	Talkgroup Short Data Call Service	0 <sub>2</sub>	Not Applicable
0110 <sub>2</sub>	Short Data Polling Service	0 <sub>2</sub>	Not Applicable
0111 <sub>2</sub>	Status Transport Service	0 <sub>2</sub>	Not Applicable
1000 <sub>2</sub>	Call Diversion Service	0 <sub>2</sub>	Not Applicable
1001 <sub>2</sub>	P_AHOY Radio Check to an individual MS address	0 <sub>2</sub>	General check for presence irrespective of the Service being supported
	P_AHOY Radio Check to a talkgroup	1 <sub>2</sub>	
1010 <sub>2</sub> to 1100 <sub>2</sub>	Reserved	0 <sub>2</sub>	Reserved
1101 <sub>2</sub> (see note)	C_AHOY Stun/Revive	0 <sub>2</sub>	Stun
		1 <sub>2</sub>	Revive
	C_AHOY Kill	0 <sub>2</sub>	Not Applicable
1110 <sub>2</sub>	Registration/Authentication Challenge/MS radio check	0 <sub>2</sub>	Not Applicable
1111 <sub>2</sub>	Cancel Call Service	0 <sub>2</sub>	Not Applicable
<b>Payload Channel</b>			
0000 <sub>2</sub>	P_AHOY Voice Service Individual Radio Check	0 <sub>2</sub>	
0001 <sub>2</sub>	P_AHOY Voice Service Talkgroup Radio Check	0 <sub>2</sub>	
0010 <sub>2</sub>	P_AHOY Packet Data individual radio check	0 <sub>2</sub>	
0011 <sub>2</sub>	P_AHOY Packet Data talkgroup radio check	0 <sub>2</sub>	
1001 <sub>2</sub>	P_AHOY Radio Check to an individual MS address	0 <sub>2</sub>	General check for presence irrespective of the Service being supported
	P_AHOY Radio Check to a talkgroup	1 <sub>2</sub>	
1111 <sub>2</sub>	P_AHOY clear an individual MS from a voice payload channel	0 <sub>2</sub>	0 <sub>2</sub> Indicates that the target is an individual Address
1111 <sub>2</sub>	P_AHOY clear a talkgroup from a voice payload channel	1 <sub>2</sub>	1 <sub>2</sub> Indicates that the target is a talkgroup
NOTE: Service_Kind = 1101 <sub>2</sub> is the supplementary data service. The purpose is further defined by the Gateway ID defined in that PDU.			

## 7.2.12.2 UDT\_Option\_Flag

Table 7.48: UDT\_Option\_Flag information element

UDT is supporting	Message	UDT_Option_Flag_Value	Remark
Voice Service (Service Kind - 0000 <sub>2</sub> ) Packet Data (Service_Kind - 0010 <sub>2</sub> )	UDTHD Outbound PDU carrying Supplementary Data	0 <sub>2</sub>	Check if called MS is in radio contact and can accept this call immediately. (OACSU)
		1 <sub>2</sub>	checks whether called MS is ready to accept speech or data call. (FOACSU)
All other Services	UDTHD	0 <sub>2</sub>	Reserved

## 7.2.13 Service\_Options

The number of Service\_Options that are applicable is dependent on the DMR service requested. The Service\_Options information element has a length of 7 bits and is illustrated for each applicable service in clauses 7.2.13.1 to 7.2.13.9.

## 7.2.13.1 Service\_Options for a Voice Service Request

The Service\_Options information for the Voice Service request is illustrated in table 7.49.

Table 7.49: Service\_Options for Voice Service Request

Information element	Length	Value	Remark
Emergency	1	0 <sub>2</sub>	Non-emergency service
		1 <sub>2</sub>	Emergency service
Privacy	1	0 <sub>2</sub>	(See note 1)
Supplementary Data	1	0 <sub>2</sub>	No Supplementary Data Transfer Service required for this call
		1 <sub>2</sub>	Supplementary Data Transfer Service requested for this call
Broadcast	1	0 <sub>2</sub>	Non-broadcast service
		1 <sub>2</sub>	Broadcast service (see note 3)
Open Voice Call Mode (OVCM)	1	0 <sub>2</sub>	Non-OVCM call
		1 <sub>2</sub>	OVCM call
Priority level	2	00 <sub>2</sub>	No priority
		01 <sub>2</sub>	Priority 1 (see note 2)
		10 <sub>2</sub>	Priority 2 (see note 2)
		11 <sub>2</sub>	Priority 3 (see note 2)
NOTE 1: Privacy is not defined in the present document.			
NOTE 2: Priority 3 is the highest priority.			
NOTE 3: Broadcast is applicable to talkgroups.			

### 7.2.13.2 Service\_Options for a Packet Data Service Request

The Service\_Options information for the Packet Data Service request is illustrated in table 7.50.

**Table 7.50: Service\_Options for Packet Data Service Request**

Information element	Length	Value	Remark
Emergency	1	0 <sub>2</sub>	Non-emergency service
		1 <sub>2</sub>	Emergency service
Privacy	1	0 <sub>2</sub>	Privacy (see note 1)
Supplementary Data	1	0 <sub>2</sub>	No Supplementary Data Transfer Service required for this call
		1 <sub>2</sub>	Supplementary Data Transfer Service requested for this call
Hi Rate	1	0 <sub>2</sub>	Payload channel expects single slot data timing
		1 <sub>2</sub>	Payload channel expects dual slot data timing
Open Voice Call Mode (OVCM)	1	0 <sub>2</sub>	Non-OVCM call
		1 <sub>2</sub>	OVCM call
Priority level	2	00 <sub>2</sub>	No priority
		01 <sub>2</sub>	Priority 1 (see note 2)
		10 <sub>2</sub>	Priority 2 (see note 2)
		11 <sub>2</sub>	Priority 3 (see note 2)
NOTE 1: Privacy is not defined in the present document.			
NOTE 2: Priority 3 is the highest priority.			

### 7.2.13.3 Service\_Options for a Call Diversion Service Request

The Service\_Options information for the call diversion Service request is illustrated in table 7.51. The Divert Kind information element determines to which call service the call diversion shall be applicable.

**Table 7.51: Service\_Options for Call Diversion Service Request**

Information element	Length	Value	Remark
Emergency	1	0 <sub>2</sub>	Not applicable
Privacy	1	0 <sub>2</sub>	See note
Divert Set/Clear	1	0 <sub>2</sub>	Clear Call Diversion
		1 <sub>2</sub>	Set Call Diversion
Divert Kind	1	Active 1 <sub>2</sub>	Divert applicable to Voice Calls
	1		Divert applicable to Packet Data Calls
	1	Inactive 0 <sub>2</sub>	Divert applicable to Short Data Calls
	1		Divert applicable to Status Calls
NOTE: Privacy is not defined in the present document.			

### 7.2.13.4 Service\_Options for a Registration Service Request

The Service\_Options information for the registration service request is illustrated in table 7.52.

**Table 7.52: Service\_Options for the Registration Service**

Information element	Length	Value	Remark
Reserved	1	0 <sub>2</sub>	
Privacy	1	0 <sub>2</sub>	(See note)
IP_Inform	1	0 <sub>2</sub>	MS is not advising IP connection
		1 <sub>2</sub>	MS is advising IP connection
PowerSave_RQ	3	000 <sub>2</sub>	Power Save not requested
		001 <sub>2</sub> to 111 <sub>2</sub>	Power Save requested
Reg_Dereg	1	0 <sub>2</sub>	If IP_Inform=0 <sub>2</sub> the MS is attempting to de-register If IP_Inform=1 <sub>2</sub> the MS is deleting an IP connection
		1 <sub>2</sub>	If IP_Inform=0 <sub>2</sub> the MS is attempting to register If IP_Inform=1 <sub>2</sub> the MS is attempting to register and/or adding an IP connection
NOTE: Privacy is not defined in the present document.			

### 7.2.13.5 Service\_Options for an Include Call Service Request

The Service\_Options information for the include service request is illustrated in table 7.53. Include call service requests shall be restricted to the payload channel.

**Table 7.53: Service\_Options for the Include Call Service**

Information element	Length	Value	Remark
Reserved	1	0 <sub>2</sub>	
Privacy	1	0 <sub>2</sub>	See note
Reserved	5	0 0000 <sub>2</sub>	
NOTE: Privacy is not defined in the present document.			

### 7.2.13.6 Service\_Options for a Status Transport Request

The Service\_Options information for the Status Transport Request is illustrated in table 7.54. The Status Transport call service requests shall be restricted to the control channel.

**Table 7.54: Service\_Options for the Status Transport Service**

Information element	Length	Value	Remark
Reserved	1	0 <sub>2</sub>	Reserved
Supplementary_user Data	1	0 <sub>2</sub>	No supplementary_user data transfer requested
		1 <sub>2</sub>	Supplementary_user data is requested for this call
Status (most significant 5 bits)	5	value	Most significant 5 bits of the status to be transported, (see note)
NOTE: The status is not part of the Service options but is illustrated in this clause for clarity.			

### 7.2.13.7 Service\_Options for the Short Data Service

The Service\_Options information for the Short Data Service request is illustrated in table 7.55.

**Table 7.55: Service\_Options for Short Data Service Request**

Information element	Length	Value	Remark
Emergency	1	0 <sub>2</sub>	Not applicable - 0 <sub>2</sub>
Privacy	1	0 <sub>2</sub>	Privacy (see note)
Supplementary Data	1	0 <sub>2</sub>	No Supplementary Data Transfer Service required for this call
		1 <sub>2</sub>	Supplementary Data Transfer Service requested for this call
BCAST_SV	1	0 <sub>2</sub>	Not applicable - 0 <sub>2</sub>
Open Voice Call Mode (OVCM)	1	0 <sub>2</sub>	Not applicable - 0 <sub>2</sub>
PRIORITY	2	00 <sub>2</sub>	Not applicable - 00 <sub>2</sub>
NOTE: Privacy is not defined in the present document.			

### 7.2.13.8 Service Options for the Supplementary Data Service

The Service\_Options information for the Supplementary Data Service request is illustrated in table 7.56.

**Table 7.56: Service\_Options for Supplementary Data Service Request**

Information element	Length	Value	Remark
Emergency	1	0 <sub>2</sub>	Not applicable - 0 <sub>2</sub>
Privacy	1	0 <sub>2</sub>	Privacy (see note)
	1	0 <sub>2</sub>	Not applicable - 0 <sub>2</sub>
	1	0 <sub>2</sub>	Not applicable - 0 <sub>2</sub>
	1	0 <sub>2</sub>	Not applicable - 0 <sub>2</sub>
PRIORITY	2	00 <sub>2</sub>	Not applicable - 00 <sub>2</sub>
NOTE: Privacy is not defined in the present document.			

### 7.2.13.9 Service Options for a Short Data Polling Request

The Service\_Options information for the Short Data Polling Service request is illustrated in table 7.57.

**Table 7.57: Service\_Options for Short Data Polling Service Request**

Information element	Length	Value	Remark
Emergency	1	0 <sub>2</sub>	Not applicable - 0 <sub>2</sub>
Privacy	1	0 <sub>2</sub>	Privacy (see note)
Supplementary Data	1	0 <sub>2</sub>	Not applicable - 0 <sub>2</sub>
Polling Format	4	0 <sub>2</sub>	Format of the data to be polled
NOTE: Privacy is not defined in the present document.			

## 7.2.14 Service\_Options\_Mirror

The Service\_Options\_Mirror information element is transmitted in C\_AHOY PDUs.

If the C\_AHOY PDU has been transmitted as an immediate (or delayed) acknowledgement to a C\_RAND Service request, the Service\_Options\_Mirror is set to the Service\_Options information element from the C\_RAND PDU.

### 7.2.14.1 Service\_Options\_Mirror for MS Authentication

If the C\_AHOY PDU has been transmitted as the result of a polling PDU from the TSCC for Authentication, then the Service\_Option\_Mirror shall be set to the values specified in table 7.58.

**Table 7.58: Service\_Options\_Mirror for MS Authentication Poll**

Information element		Length	Value	Remark
Service_Options_Mirror	Reserved	1	0 <sub>2</sub>	
	Privacy	1	0 <sub>2</sub>	See note
	Reserved	5	0 0000 <sub>2</sub>	
NOTE: Privacy is not defined in the present document.				

### 7.2.14.2 Service\_Options\_Mirror for MS Stun/Revive

If the C\_AHOY PDU has been transmitted as the result of a polling PDU from the TSCC for MS stun/revive then the Service\_Option\_Mirror shall be set to the values specified in table 7.59.

**Table 7.59: Service\_Options\_Mirror for MS Stun/Revive Poll**

Service_Options_Mirror	Reserved	1	0 <sub>2</sub>	
	Privacy	1	0 <sub>2</sub>	See note
	Reserved	5	0 0000 <sub>2</sub>	
NOTE: Privacy is not defined in the present document.				

NOTE: Stun/Revive is a secondary service.

### 7.2.14.3 Service\_Options\_Mirror for MS Kill

If the C\_AHOY PDU has been transmitted as the result of a polling PDU from the TSCC for MS stun/revive then the Service\_Option\_Mirror shall be set to the values specified in table 7.60.

**Table 7.60: Service\_Options\_Mirror for MS Kill**

Service_Options_Mirror	Reserved	1	0 <sub>2</sub>	
	Privacy	1	0 <sub>2</sub>	See note
	Reserved	5	0 0000 <sub>2</sub>	
NOTE: Privacy is not defined in the present document.				

## 7.2.15 Proxy Flag

For calls to destinations connected through a TS gateway, the proxy flag indicates the number of Appended Data UDTs needed to upload the address of the final destination. For a call to a PABX or the PSTN, one appended data UDT will carry up to 20 dialled digits and two appended data UDTs will carry up to 44 dialled digits.

Table 7.61: Proxy Flag information element

Information element	Length	Value	Remark
Proxy Flag	1	0 <sub>2</sub>	Number of appended data MBCs needed to upload the final destination address = 1 Number of Extended BCD digits for addressing through a PSTN/PABX gateway = 1 to 20. For IP gateway extended_address is IPV4
		1 <sub>2</sub>	Number of appended data UDTs needed to upload the final destination address = 2 Number of Extended BCD digits for addressing through a PSTN/PABX gateway = 21 to 44. For IP gateway extended_address is IPV6Number

## 7.2.16 POL\_FMT

For all POL\_FMT values in the range 0000<sub>2</sub> to 1001<sub>2</sub>, POL\_FMT specifies the format of polled data from the Short Data Polling procedures specified in clause 6.6.5.3. POL\_FMT=1010<sub>2</sub> identifies the Status Polling Service specified in clause 6.6.6.2.

Table 7.62: POL\_FMT information element

Information element	Length	Value	Remark
POL_FMT	4	0000 <sub>2</sub>	Binary
		0001 <sub>2</sub>	MS Addresses
		0010 <sub>2</sub>	4 bit BCD
		0011 <sub>2</sub>	ISO 7 bit character set (ISO/IEC 646 [11])
		0100 <sub>2</sub>	ISO 8 bit character set (ISO/IEC 8859 [12])
		0101 <sub>2</sub>	NMEA location information
		0110 <sub>2</sub>	IP address
		0111 <sub>2</sub>	16 bit UTF-16BE Unicode characters
		1000 <sub>2</sub>	Custom Coded (manufacturer specific)
		1001 <sub>2</sub>	Custom Coded (manufacturer specific)
		1010 <sub>2</sub>	Status
		1011 <sub>2</sub>	Reserved
		1100 <sub>2</sub>	Reserved
		1101 <sub>2</sub>	Reserved
		1110 <sub>2</sub>	Reserved
1111 <sub>2</sub>	Reserved		

## 7.2.17 Appended\_Block

If the Supplementary Data Service has been invoked as an option with other voice or data services, the Appended Supplementary Data information element is used to pass the number of Appended Data UDTs needed to upload the Supplementary Data.

If the Short Data Service has been invoked, the Appended Short Data information element is used by an MS to pass the number of Appended Data UDTs needed to upload the Short Data.



**Table 7.63: Appended Supplementary Data information element**

Information element	Length	Alias	Value	Remark
Appended_Block	2	UAB	00 <sub>2</sub>	Number of appended data UDTs needed to upload the supplementary data = 1
			01 <sub>2</sub>	Number of appended data UDTs needed to upload the supplementary data = 2
			10 <sub>2</sub>	Number of appended data UDTs needed to upload the supplementary data = 3
			11 <sub>2</sub>	Number of appended data UDTs needed to upload the supplementary data = 4

## 7.2.18 Opcode

The Opcode information element specifies the function of a UDT Header.

**Table 7.64: Opcode**

Information element	Length	Value	Remark
Opcode	6	00 0000 <sub>2</sub>	MBC is a UDT header
		00 0001 <sub>2</sub> to 11 1111 <sub>2</sub>	Reserved

## 7.2.19 Announcement type

The Announcement type Format Code information element has a length of 5 bits and is illustrated in figure 7.2.

**Table 7.65: Announcement type**

Information element	Length	Value	Alias	Remark
Announcement_type	5	0 0000 <sub>2</sub>	Ann-WD_TSCC	Announce/Withdraw TSCC
		0 0001 <sub>2</sub>	CallTimer_Parms	Specify Call Timer Parameters
		0 0010 <sub>2</sub>	Vote_Now	Vote Now Advice
		0 0011 <sub>2</sub>	Local_Time	Broadcast Local Time
		0 0100 <sub>2</sub>	MassReg	Mass_Registration
		0 0101 <sub>2</sub>	Chan_Freq	Announce a logical channel / frequency relationship
		0 0110 <sub>2</sub>	Adjacent_Site	Adjacent Site information
		0 0111 <sub>2</sub> to 1 1101 <sub>2</sub>		Reserved
		1 1110 <sub>2</sub>		Manufacturer Specific
1 1111 <sub>2</sub>		Manufacturer Specific		

## 7.2.19.1 Announce/Withdraw TSCC (Ann-WD\_TSCC)

Table 7.66: Announce/Withdraw TSCC

Information element	Length	Value	Alias	Remark
Broadcast Parms 1	4	0 <sub>2</sub>		Reserved
	4	Value		Colour code for CH_1 (default=0000 <sub>2</sub> )
	4	Value		Colour Code for CH_2 (default=0000 <sub>2</sub> )
	1	0 <sub>2</sub>	AW_FLAG1	Add BCAST_CH1 to hunt list
		1 <sub>2</sub>		Withdraw BCAST_CH1 from hunt list
	1	0 <sub>2</sub>	AW_FLAG2	Add BCAST_CH2 to hunt list
1 <sub>2</sub>			Withdraw BCAST_CH2 from hunt list	
Broadcast Parms 2	12	0 or 1 to 4 095	BCAST_CH1	CHNULL or Logical Physical Channel Number
	12	0 or 1 to 4 095	BCAST_CH2	CHNULL or Logical Physical Channel Number

## 7.2.19.2 Specify Call Timer Parameters (CallTimer\_Parms)

Table 7.67: Specify Call Timer Parameters

Information element	Length	Value	Alias	Remark
Broadcast Parms 1	9	0 <sub>2</sub>	T_EMERG_TIMER	MS uses its Internal Emergency Timer
		1 to 510		Call Timer for Emergency Calls. See Appendix A1
		511		Emergency Call Timer is Infinity
	5	0	T_PACKET_TIMER	MS uses its Internal Packet Timer
		1 to 30		Call Timer for Packet Data. See Appendix A1
		31		Packet Call Timer is Infinity
Broadcast Parms 2	12	0	T_MS-MS_TIMER	MS uses its Internal Timer for MS to MS calls
		1 to 4 094		Call Timer for MS to MS Calls. See Appendix A1
		4 095		MS to MS Call Timer is Infinity
	12	0	T_MS-LINE_TIMER	MS uses its Internal Timer for line connected calls
		1 to 4 094		Call Timer for Line Connected calls. See Appendix A1
		4 095		Line Connected Call Timer is Infinity

## 7.2.19.3 Vote Now Advice (Vote\_Now)

Table 7.68: Vote Now Advice

Information element	Length	Value	Alias	Remark
Broadcast Parms 1	14			Most Significant 14 bits of the System Identity Code of the TSCC being assessed
Broadcast Parms 2	1			If 1, Active_connection information available, if 0, Active_connection information not available.
	1			Active_connection
	3			Confirmed channel priority
	3			Adjacent channel priority
	4	0000	Reserved	
	12	1 to 4 095	CH_VOTE	Physical Channel Number to be assessed

## 7.2.19.4 Broadcast Local Time (Local\_Time)

Table 7.69: Broadcast Local Time

Information element	Length	Value	Alias	Remark
Broadcast Params 1	5		B_DAY	Day of the Month 1 to 31 (or 0 if date is not being broadcast)
	4		B_MONTH	Month 1 to 12 (or 0 if month is not being broadcast)
	5		UTC_OFFSET	Offset between local hours and UTC hours (as a number in the range 0 to 23 (or 1111 <sub>2</sub> if offset is not being broadcast))
Broadcast Params 2	5		B_HOURS	Hours 0 to 23
	6		B_MINS	Minutes 0 to 59
	6		B_SECS	Seconds 0 to 59
	3		DAYOF_WEEK	The day of the week (or 0 if the day of week is not being broadcast)
	2	00 <sub>2</sub>	UTC_OFFSET_FR ACTION	No additional offset
		01 <sub>2</sub>		Add 15 minutes
		10 <sub>2</sub>		Add 30 minutes
		11 <sub>2</sub>		Add 45 minutes
4	00 <sub>2</sub>		Reserved	

The information element meaning of B\_MONTH and DAYOF\_WEEK values are specified in tables 7.70 and 7.71.

## 7.2.19.4.1 Broadcast Local Time - Month (B\_MONTH)

Table 7.70: B\_MONTH information element

Information element	Length	Value	Remark
B_MONTH	4	0000 <sub>2</sub>	<Month not broadcast>
		0001 <sub>2</sub>	January
		0010 <sub>2</sub>	February
		0011 <sub>2</sub>	March
		0100 <sub>2</sub>	April
		0101 <sub>2</sub>	May
		0110 <sub>2</sub>	June
		0111 <sub>2</sub>	July
		1000 <sub>2</sub>	August
		1001 <sub>2</sub>	September
		1010 <sub>2</sub>	October
		1011 <sub>2</sub>	November
		1100 <sub>2</sub>	December

## 7.2.19.4.2 Broadcast Local Time - Day of Week (DAYSOF\_WEEK)

Table 7.71: DAYSOF\_WEEK information element

Information element	Length	Value	Remark
DAYSOF_WEEK	3	000 <sub>2</sub>	<Days of Week not broadcast>
		001 <sub>2</sub>	Sunday
		010 <sub>2</sub>	Monday
		011 <sub>2</sub>	Tuesday
		100 <sub>2</sub>	Wednesday
		101 <sub>2</sub>	Thursday
		110 <sub>2</sub>	Friday
		111 <sub>2</sub>	Saturday

## 7.2.19.5 Broadcast Mass Registration (MassReg)

Table 7.72: Mass Registration

Information element	Length	Value	Alias	Remark
Broadcast Params 1	5	0 0000 <sub>2</sub>		Reserved
	4			Reg_Window
	5			Aloha Mask
Broadcast Params 2	24			NULL or MS Individual Address

## 7.2.19.5.1 Reg\_Window

Table 7.73: Reg\_Window

Information element	Length	Value	Treg_Window	Remark
Reg_Window	4	0		<Cancel Mass Registration>
		1	.5	Values in Seconds
		2	1	
		3	2	
		4	5	
		5	10	
		6	20	
		7	30	
		8	100	
		9	300	
		10	1 000	
		11	3 000	
		12	10 000	
		13	30 000	
		14	100 000	
15	200 000			

## 7.2.19.6 Broadcast Adjacent Site information

Table 7.74: Broadcast Adjacent Site information

Information element	Length	Value	Alias	Remark
Broadcast Parms 1	14			Most Significant 14 bits of the System Identity Code of the TSCC being assessed
Broadcast Parms 2	1			If 1, Active_connection information available, if 0, Active_connection information not available.
	1			Active_connection
	3			Confirmed channel priority
	3			Adjacent channel priority
	4	0000 <sub>2</sub>	Reserved	
	12	1 to 4 095	CH_VOTE	Physical Channel Number of the Adjacent Site to be assessed

## 7.2.19.7 CdefParms absolute frequency relationship

Table 7.75: CdefParms information element Definition

CdefParms	Information element	Length	Value	Alias	Remark
	<b>CdefParms</b>				
Cdeftype=0000 <sub>2</sub>	Logical Physical Channel Number	12		CHAN	
	Absolute transmitter frequency - integer MHz	10		TXMHz	Absolute transmitter frequency - integer MHz
	Absolute transmitter frequency	13		TXKHz	Part transmitter MHz in 125 Hz steps
	Absolute receiver frequency - integer MHz	10		RXMHz	Absolute transmitter frequency - integer MHz
	Absolute receiver frequency	13		RXKHz	Part receiver MHz in 125 Hz steps
	<b>CdefParms</b>				
Cdeftype=0001 <sub>2</sub> to 1111 <sub>2</sub>		58	Reserved		

The mechanism for calculating the absolute frequency is defined in annex C.

## 7.2.20 Individual/Group (IG)

Table 7.76: IG information element Definition

Information element	Length	Value	Alias	Remark
IG	1	0 <sub>2</sub>	G/I	The Target Address information element in the PDU represents an individual MS address
		1 <sub>2</sub>		The Target Address information element in the PDU represents a talkgroup

## 7.2.21 Protect\_Kind

Table 7.77: Protect\_Kind information element Definition

Information element	Length	Value	Alias	Remark
Protect_Kind	3	000 <sub>2</sub>	DIS_PTT	Disable Target MS or Talkgroup transmission
		001 <sub>2</sub>	EN_PTT	Enable Target MS or Talkgroup transmission
		010 <sub>2</sub>	ILLEGALLY_PARKED	Clear down from the payload channel, MS whose address does not match Source or Target Address
		011 <sub>2</sub>		Reserved
		100 <sub>2</sub>		Reserved
		101 <sub>2</sub>		Reserved
		110 <sub>2</sub>		Reserved
		111 <sub>2</sub>		Reserved

## 7.2.22 Maint\_Kind

Table 7.78: Maint\_Kind information element Definition

Information element	Length	Value	Alias	Remark
Maint_Kind	3	000 <sub>2</sub>	DISCON	Disconnect. End of payload channel use
		001 <sub>2</sub>		Reserved
		010 <sub>2</sub>		Reserved
		011 <sub>2</sub>		Reserved
		100 <sub>2</sub>		Reserved
		101 <sub>2</sub>		Reserved
		110 <sub>2</sub>		Reserved
		111 <sub>2</sub>		Reserved

## 7.2.23 Response expected (A)

Table 7.79: A information element Definition

Information element	Length	Value	Alias	Remark
A	1	0 <sub>2</sub>		Response not expected
		1 <sub>2</sub>		Response expected

## 7.2.24 Format

Table 7.80: Format information element

Information element	Length	Value	Remark
Format	4	0000 <sub>2</sub>	header for UDT
		0001 <sub>2</sub>	Reserved
		0010 <sub>2</sub>	Reserved
		0011 <sub>2</sub>	Reserved
		0100 <sub>2</sub>	Reserved
		0101 <sub>2</sub>	Reserved
		0110 <sub>2</sub>	Reserved
		0111 <sub>2</sub>	Reserved
		1000 <sub>2</sub>	Reserved
		1001 <sub>2</sub>	Reserved
		1010 <sub>2</sub>	Reserved
		1011 <sub>2</sub>	Reserved
		1100 <sub>2</sub>	Reserved
		1101 <sub>2</sub>	Reserved
		1110 <sub>2</sub>	Reserved
		1111 <sub>2</sub>	Reserved

## 7.2.25 Service Access Point (SAP)

Table 7.81: SAP information element

Information element	Length	Value	Remark
SAP	4	0000 <sub>2</sub>	UDT
		0001 <sub>2</sub>	See TS 102 361-1 [5]
		0010 <sub>2</sub>	See TS 102 361-1 [5]
		0011 <sub>2</sub>	See TS 102 361-1 [5]
		0100 <sub>2</sub>	See TS 102 361-1 [5]
		0101 <sub>2</sub>	See TS 102 361-1 [5]
		0110 <sub>2</sub>	See TS 102 361-1 [5]
		0111 <sub>2</sub>	See TS 102 361-1 [5]
		1000 <sub>2</sub>	See TS 102 361-1 [5]
		1001 <sub>2</sub>	See TS 102 361-1 [5]
		1010 <sub>2</sub>	See TS 102 361-1 [5]
		1011 <sub>2</sub>	See TS 102 361-1 [5]
		1100 <sub>2</sub>	See TS 102 361-1 [5]
		1101 <sub>2</sub>	See TS 102 361-1 [5]
		1110 <sub>2</sub>	See TS 102 361-1 [5]
		1111 <sub>2</sub>	See TS 102 361-1 [5]

## 7.2.26 Pad Nibble (PN)

The PN information element specifies the number of pad nibbles which have been appended to the data to form an integer number of blocks. The number of pad nibbles for each of the UDT data formats is specified in annex B.

**Table 7.82: Pad Nibble**

Information element	Length	Value	Remark
Pad Nibble	5	Value	Number of pad nibbles appended to the data

## 7.2.27 UDT Format

Specifies the format of the user or system data carried in UDTs for the UDT mechanism.

**Table 7.83: UDT\_Format information element**

Information element	Length	Value	Remark
UDT Format	4	0000 <sub>2</sub>	Binary
		0001 <sub>2</sub>	MS Address
		0010 <sub>2</sub>	4 bit BCD
		0011 <sub>2</sub>	ISO 7 bit character set (ISO/IEC 646 [11])
		0100 <sub>2</sub>	ISO 8 bit character set (ISO/IEC 8859 [12])
		0101 <sub>2</sub>	NMEA location coded (IEC 61162-1 [8])
		0110 <sub>2</sub>	IP address
		0111 <sub>2</sub>	16 bit UTF-16BE Unicode characters
		1000 <sub>2</sub>	Custom Coded (manufacturer specific)
		1001 <sub>2</sub>	Custom Coded (manufacturer specific)
		1010 <sub>2</sub>	Reserved
		1011 <sub>2</sub>	Reserved
		1100 <sub>2</sub>	Reserved
		1101 <sub>2</sub>	Reserved
1110 <sub>2</sub>	Reserved		
1111 <sub>2</sub>	Reserved		

## 7.2.28 Offset

On the outbound channel, specifies if the payload channel shall use offset or aligned timing.

**Table 7.84: Offset information element**

Information element	Length	Value	Remark
Offset	1	0 <sub>2</sub>	The payload channel shall use aligned timing
		1 <sub>2</sub>	The payload channel shall use offset timing



## 7.2.29 Protect Flag (PF)

The Protect Flag is described in table 7.85.

**Table 7.85: Protect Flag**

Information element	Length	Value	Remark
Protect Flag (PF)	1	0 <sub>2</sub>	Defined in TS 102 361-1 [5] Air Interface

## 7.2.30 Privacy

Privacy is described in table 7.86.

**Table 7.86: Privacy**

Information element	Length	Value	Remark
Privacy	1	0 <sub>2</sub>	Defined in TS 102 361-1 [5] Air Interface

## 7.2.31 STATUS

**Table 7.87: STATUS**

Information element	Length	Value	Remark
STATUS	7	000 0000 <sub>2</sub> to 111 1110 <sub>2</sub>	Status Values valid for the Status Delivery Service
		111 1111 <sub>2</sub>	Status Value for the Status Polling Service

## 7.2.32 Version

**Table 7.88: Version**

Information element	Length	Value	Remark
		000 <sub>2</sub>	This system is compliant with TS 102 361-4 [i.1] version 1.5.1
		001 <sub>2</sub>	This system is compliant with TS 102 361-4 [i.1] version 1.6.1
		010 <sub>2</sub> to 111 <sub>2</sub>	Reserved

The Version Information element indicates the version number to which the system is compliant.

## Annex A (normative): Timers, constants levels and addresses

This annex lists the timers and constants in a DMR MS.

Where indicated, a value should be chosen from within the specified range. For other timers and constants, a default value may be specified and the value of these timers and constants shall be configurable within the DMR entity (MS, BS or TS).

### A.1 Layer 3 timers

**Table A.1: Layer 3 Timers**

Mnemonic	Value	Description
Trand_TC	2 seconds to 60 seconds	Timeout for MS attempting Random Access
T_Nosig	1 second to 15 seconds	Timeout for entering hunting procedures if no TSCC is received
T_EMERG_TIMER	1 to 510	Emergency Timer. See table A.2
	511	Emergency Timer is Infinity
T_PACKET_TIMER	1 to 30	Packet Timer. See table A.3
	31	Packet Timer is Infinity
T_MS-MS_TIMER	1 to 4 094	MS to MS Timer. See table A.4
	4 095	MS to MS Timer is Infinity
T_MS-LINE_TIMER	1 to 4 094	MS-Line Timer. See table A.5
	4 095	MS-Line Timer is Infinity
TP_Timer	4 seconds to 60 seconds	Timeout for a calling MS waiting for a call that requires a payload channel
TNP_Timer	2 seconds to 60 seconds	Timeout for a calling MS waiting for a call that does not require a payload channel
T_Awake	0,1 to 60 seconds	Time MS stays awake after receiving a PDU (in steps of 0,1 second)
TV_Hangtime	1 second to 60 seconds	Payload Voice Hangtime timer
TV_Item	10 seconds to 60 seconds	Payload Voice Maximum Item Timer
TV_Inactive	0 seconds to 20 seconds	Payload Voice Inactivity Timer
TD_Inactive	0 seconds to 20 seconds	Payload Data inactivity Timer
TD_Item	1 second to 60 seconds	Payload Packet Data Maximum Item Timer
T_AnswerCall	2 seconds to 60 seconds	Timeout for called MS after receiving AHOY for FOASCU
T_Pending	2 seconds to 60 seconds	Timeout for called MS after receiving AHOY for OACSU
T_dereg	0,2 seconds to 2 seconds	Timer to de-register before abandon in 0,1 second steps
T_BS_Inactive	1 second to 300 seconds	Timer to hibernate if no inbound activity on an unregulated TSCC
T_DENREG	0	The denied registration timer is inactive
	1 to 1 000	Denied registration lifetime in steps of 10 seconds (e.g. 1 = 10 seconds, 2 = 20 seconds, etc.)

**Table A.2: Call Timer Tokens T\_EMERG\_TIMER**

Alias	Value	Meaning
T_EMERG_TIMER	1 to 10	Call Timer in seconds
	11 to 20	Call timer in increments of 5 s from - 11 = 15 s to 20 = 60 s
	21 to 28	Call timer in increments of 15 s from - 21 = 75 s to 28 = 180 s
	29 to 40	Call timer in increments of 30 s from - 29 = 3,5 minutes to 40 = 9 minutes
	41 to 51	Call timer in increments of 1 minute from - 41 = 10 minutes to 51 = 20 minutes
	52 to 510	Call timer in increments of 5 minutes from - 52 = 25 minutes to 510 = 2 315 minutes
	511	Call timer is infinity

**Table A.3: Call Timer Tokens T\_PACKET\_TIMER**

Alias	Value	Meaning
T_PACKET_TIMER	1 to 5	Call Timer in seconds
	6 to 10	Call timer in increments of 5 s from - 6 = 10 s to 10 = 30 s
	11 to 12	Call timer in increments of 15 s from - 11 = 45 s to 12 = 60 s
	13 to 20	Call timer in increments of 30 s from - 13 = 1,5 minutes to 20 = 5 minutes
	21 to 25	Call timer in increments of 1 minute from - 21 = 6 minutes to 25 = 10 minutes
	26 to 30	Call timer in increments of 5 minutes from - 26 = 15 minutes to 30 = 35 minutes
	31	Call timer is infinity

**Table A.4: Call Timer Tokens T\_MS-MS\_TIMER**

Alias	Value	Meaning
T_MS-MS_TIMER	1 to 59	Call Timer in seconds
	60 to 107	Call timer in increments of 5 s from - 60 = 60 s to 107 = 295 s
	108 to 138	Call timer in increments of 30 s from - 108 = 5 minutes to 138 = 20 minutes
	139 to 4 094	Call timer in increments of 1 minute from - 139 = 21 minutes to 4 094 = 3 976 minutes
	4 095	Call timer is infinity

Table A.5: Call Timer Tokens T\_MS-LINE\_TIMER

Alias	Value	Meaning
T_MS-LINE_TIMER	1 to 59	Call Timer in seconds
	60 to 107	Call timer in increments of 5 s from - 60 = 60 s to 107 = 295 s
	108 to 138	Call timer in increments of 30 s from - 108 = 5 minutes to 138 = 20 minutes
	139 to 4 094	Call timer in increments of 1 minute from - 139 = 21 minutes to 4 094 = 3 976 minutes
	4 095	Call timer is infinity

## A.2 Layer 3 constants

Table A.6: Layer 3 Constants

Mnemonic	Value	Description
NDefault_NW	5	NRand_Wait at MS switch on
NRand_NR	6	Number of random access attempts for a normal and high priority service
NRand_NE	10	Number of random access attempts for a emergency priority service
N_Maint	4	Number of P_MAINT PDUs transmitted by an MS to clear down the payload channel
Nmax_Ch	50	Minimum Number of channels in Short Hunt List
Ch_Pref	50	Channels that are marked as Preferred TSCC for Vote_Now
Low_Comp_Ch	1 to 4 095	Lowest logical channel in use by the network
High_Comp_Ch	Low_Comp_Ch to 4 095	Highest logical channel in use by the network
Comp_Flag	True/False	Suppress Comprehensive Hunt (see annex D)
NSYSerr	1 to 3	Number of C_SYSCodes received that differ from the value verified
DMRLA	0 to 10	Length of SYS_AREA information field from the C_SYSCode
VOTE_BLK	2 to 10	Number of TDMA frames that random access activity is withdrawn after a Vote Now Advice

## A.3 Layer 3 levels

Table A.7: Layer 3 signal levels

Mnemonic	Value	Description
L_Upper_Short	Units and values are manufacturer specific	The threshold of signal quality above which will be sampled first in a short hunt
L_Lower_Short		The threshold of signal quality below which the MS shall be unable to become active
L_Squelch		Signal level (or equivalent) below which physical channels are to be rejected because the received signal quality is inadequate
L_Power_Hi	Units and values are manufacturer specific	Lower limit of signal strength sample received by the TS for power control
L_Power_Low		Upper limit of signal strength sample received by the TS for power control

## A.4 Tier III Gateways/Identifiers

**Table A.8: Gateways / Identifiers**

<b>DMR ID</b>	<b>Alias</b>	<b>Remark</b>
FFFEC0 <sub>16</sub>	PSTNI	Gateway address for services to the PSTN using payload aligned timing
FFFEC1 <sub>16</sub>	PABXI	Gateway address for services to the PABX using payload aligned timing
FFFEC2 <sub>16</sub>	LINEI	Address for services to a Line Gateway using payload aligned timing
FFFEC3 <sub>16</sub>	IPI	Address for services to an IP Gateway using payload aligned timing
FFFEC4 <sub>16</sub>	SUPLI	Address used to identify an supplementary data service
FFFEC5 <sub>16</sub>	SDMI	Address used to identify a UDT short data service
FFFEC6 <sub>16</sub>	REGI	Address used to identify a registration service
FFFEC7 <sub>16</sub>	MSI	Address used to identify the totality of individual MS address space
FFFEC8 <sub>16</sub>		Reserved
FFFEC9 <sub>16</sub>	DIVERTI	Address used to identify a call diversion cancellation
FFFECA <sub>16</sub>	TSI	Address of the TS
FFFECA <sub>16</sub>	DISPATI	Address of the system dispatcher using payload aligned timing
FFFECC <sub>16</sub>	STUNI	MS Stun/Revive Identifier
FFFECD <sub>16</sub>	AUTHI	Authentication Identifier
FFFECE <sub>16</sub>	GPI	Talkgroup Identifier
FFFECE <sub>16</sub>	KILLI	MS KILL Identifier
FFFED0 <sub>16</sub>	PSTNDI	Gateway address for services to the PSTN using payload offset timing
FFFED1 <sub>16</sub>	PABXDI	Gateway address for services to the PABX using payload offset timing
FFFED2 <sub>16</sub>	LINEDI	Address for services to a Line Gateway using payload offset timing
FFFED3 <sub>16</sub>	DISPATDI	Address of the system dispatcher using payload offset timing
FFFED4 <sub>16</sub>	ALLMSI	The totality of all individual MS and talkgroups
FFFED5 <sub>16</sub>	IPDI	Address for services to an IP gateway using payload offset timing
FFFFFD <sub>16</sub>	ALLMSIDL	ID used to address all MS at one site as a talkgroup
FFFFFE <sub>16</sub>	ALLMSIDZ	ID used to address all MS in a subset of the system's sites as a talkgroup
FFFFFF <sub>16</sub>	ALLMSID	ID used to address all MS (AllCall) in every site in the system as a talkgroup

## Annex B (normative): Opcode Reference Lists

### B.1 CSBK/MBC/UDT Opcode List

Table B.1: CSBK/MBC/UDT Opcode List

OPCODE	OPCODE <sub>2</sub>	Description	Alias
<b>Channel Grant</b>			
48	11 0000 <sub>2</sub>	Private Voice Channel Grant	PV_GRANT
49	11 0001 <sub>2</sub>	Talkgroup Voice Channel Grant	TV_GRANT
50	11 0010 <sub>2</sub>	Private Broadcast Voice Channel Grant	BTV_GRANT
51	11 0011 <sub>2</sub>	Private Data Channel Grant	PD_GRANT
52	11 0100 <sub>2</sub>	Talkgroup Data Channel Grant	TD_GRANT
<b>Move</b>			
57	11 1001 <sub>2</sub>	Move PDUs	C_MOVE
<b>Aloha</b>			
25	01 1001 <sub>2</sub>	Aloha PDUs for the random access protocol	C_ALOHA
<b>Announcements</b>			
40	10 1000 <sub>2</sub>	Announcement PDUs that shall not demand a response. Announce/Withdraw TSCC Specify call Timers Vote now advice Announce local time Announce a logical physical channel relationship	C_BCAST
46	10 1110 <sub>2</sub>	Clear	P_CLEAR
47	10 1111 <sub>2</sub>	Protect	P_PROTECT
<b>Ahoy PDUs</b>			
28	01 1100 <sub>2</sub>	Ahoy - enquiry from the TSCC that demands a response from MS	C_AHOY P_AHOY
<b>Acknowledgements</b>			
32	10 0000 <sub>2</sub>	Acknowledgement response outbound TSCC	C_ACKD
33	10 0001 <sub>2</sub>	Acknowledgement response inbound TSCC	C_ACKU
34	10 0010 <sub>2</sub>	Acknowledgement response outbound Payload	P_ACKD
35	10 0011 <sub>2</sub>	Acknowledgement response inbound Payload	P_ACKU
<b>UDT Header</b>			
26	01 1010 <sub>2</sub>	Unified Data Transport outbound Header	C_UDTHD
27	01 1011 <sub>2</sub>	Unified Data Transport inbound Header	C_UDTHU
<b>Random Access Service Request</b>			
31	01 1111 <sub>2</sub>	Random Access Service Request	C_RAND
<b>Ackvitation</b>			
30	01 1110 <sub>2</sub>	Ackvitation PDU	C_ACKVIT
<b>Maintenance PDU</b>			
42	10 1010 <sub>2</sub>	Maintenance	P_MAINT

### B.2 Short Link Control Opcode List

Table B.2: SLCO Opcode List

SLCO	Description	Alias
0010 <sub>2</sub>	System Parameters and slot counter	SYS_Parm

## B.3 Appended Data Information Elements

A UDT PDU may carry information elements. A UDT header PDU carries the source and destination addresses and a UDT Format information element that prescribes the format of the appended data.

The UDT Header is the first block of a multi-block UDT. The number of blocks making up the multi-block UDT is specified by the UAB information element. All PDUs are specified in clause 7.2.

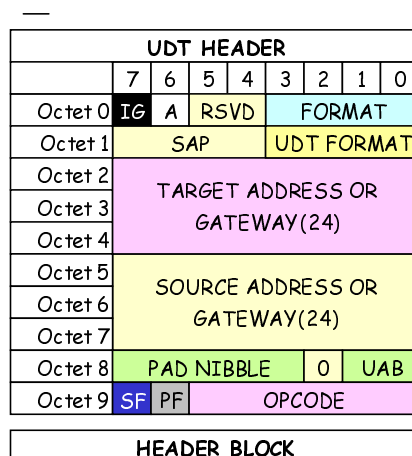

Figure B.1: UDT header Block

### B.3.1 Appended Data Binary Format

Appended data is binary coded. Up to four appended UDT blocks may be concatenated with the UDT header to form a multi-block UDT PDU. Up to 368 bits may be transported. For binary format transport the Pad Nibble information element in the UDT header is set to 0 0000<sub>2</sub>. If variable length binary data is being transported, the last bit of the user data may identified as follows:

- A 0<sub>2</sub> is appended to the user data and the remaining bits to fill a UDT block are set to 1<sub>2</sub>. The UDT header and appended blocks are then transmitted.
- The receiver may identify the end of user data by counting backwards until the first 0<sub>2</sub> is reached. That point is one bit past the user data.
- In this case the maximum number of applicable data bits is  $96 + 96 + 96 + 79 = 367$ .

The figures B.2, B.3, B.4 and B.5 assume variable length binary data is being transmitted.

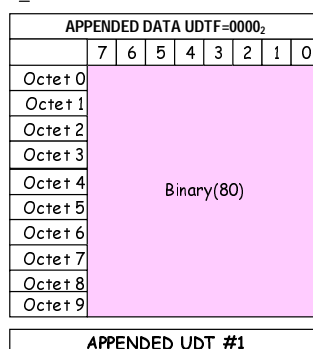
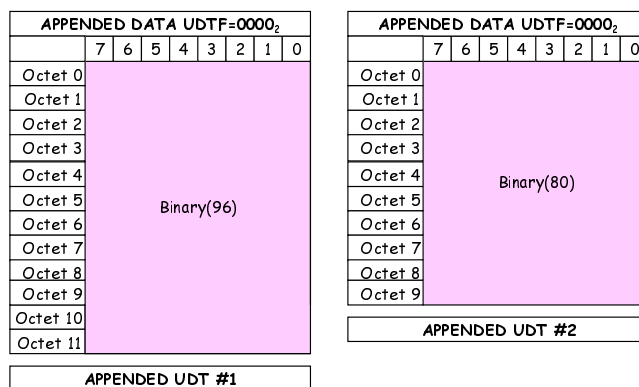

Figure B.2: Unified Data Transport Format (Binary) 1 bit to 79 bits

One appended UDT may transport from 1 bit to 79 bits (because the last user bit shall be identified by adding a 0<sub>2</sub> to the end of the user data).



**Figure B.3: Unified Data Transport Format (Binary) 80 bits to 175 bits**

Two appended UDTs may transport from 80 bits to  $(96 + 79) = 175$  bits.

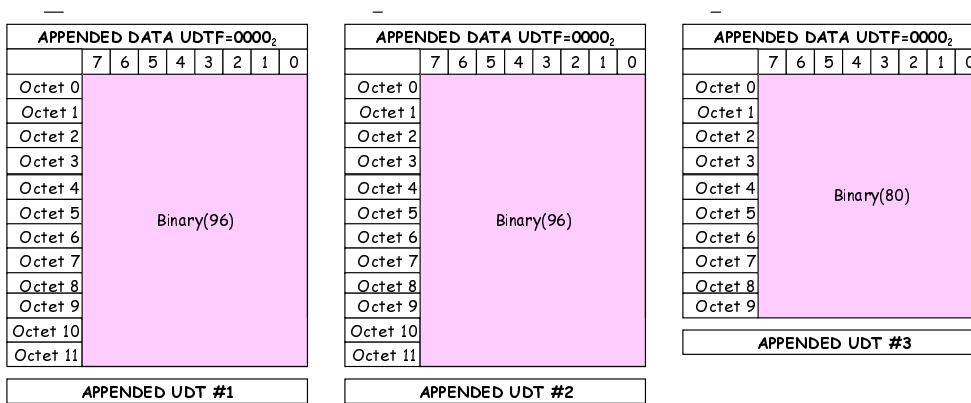

**Figure B.4: Unified Data Transport Format (Binary) 176 bits to 271 bits**

Three appended UDTs may transport from 176 bits to  $(96 + 96 + 79) = 271$  bits.

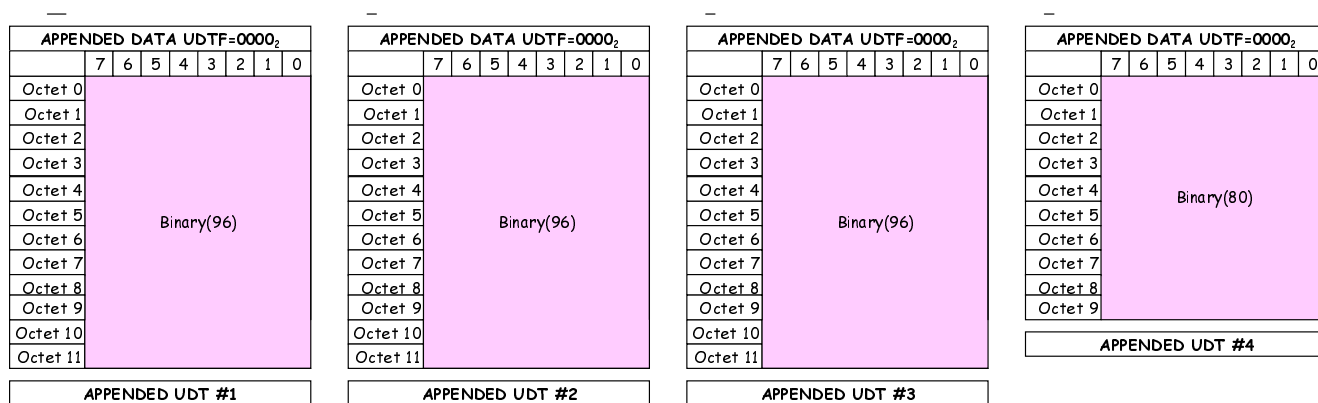

**Figure B.5: Unified Data Transport Format (Binary) 272 bits to 367 bits**

Four appended UDTs may transport from 272 bits to  $(96 + 96 + 96 + 79) = 367$  bits.



## B.3.2 Appended Data Addressing Format

Appended data is 24 bit address coded. One appended data UDTs may be concatenated with a UDT appended data header to form a multi-block UDT PDU. Up to three addresses may be transported.

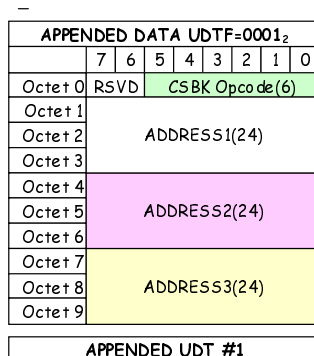

**Figure B.6: Appended data Address Format**

Unused address information elements are filled with NULL.

## B.3.3 Appended Data BCD Format

Appended data is BCD coded. Up to four appended data UDTs may be concatenated with UDT appended data header to form a multi-block UDT PDU. Up to 92 BCD digits may be transported. The Pad Nibble information element in the UDT header specifies the number of 4 bit nibbles (1111<sub>2</sub>) that have been padded to the user digits to completely fill a block.

The number of user BCD digits and the corresponding value of UAB and Pad Nibble is given by table B.3.

Clause 7.2.9 lists the abbreviated coding if the BCD digits represent telephone dialled strings.

Table B.3: Relationship of user BCD digits, UAB and Pad Nibble information elements

User BCD Digits	UAB	Pad Nibble	User BCD Digits	UAB	Pad Nibble	User BCD Digits	UAB	Pad Nibble
1	0	19	32	1	12	63	2	5
2	0	18	33	1	11	64	2	4
3	0	17	34	1	10	65	2	3
4	0	16	35	1	9	66	2	2
5	0	15	36	1	8	67	2	1
6	0	14	37	1	7	68	2	0
7	0	13	38	1	6	69	3	23
8	0	12	39	1	5	70	3	22
9	0	11	40	1	4	71	3	21
10	0	10	41	1	3	72	3	20
11	0	9	42	1	2	73	3	19
12	0	8	43	1	1	74	3	18
13	0	7	44	1	0	75	3	17
14	0	6	45	2	23	76	3	16
15	0	5	46	2	22	77	3	15
16	0	4	47	2	21	78	3	14
17	0	3	48	2	20	79	3	13
18	0	2	49	2	19	80	3	12
19	0	1	50	2	18	81	3	11
20	0	0	51	2	17	82	3	10
21	1	23	52	2	16	83	3	9
22	1	22	53	2	15	84	3	8
23	1	21	54	2	14	85	3	7
24	1	20	55	2	13	86	3	6
25	1	19	56	2	12	87	3	5
26	1	18	57	2	11	88	3	4
27	1	17	58	2	10	89	3	3
28	1	16	59	2	9	90	3	2
29	1	15	60	2	8	91	3	1
30	1	14	61	2	7	92	3	0
31	1	13	62	2	6			

APPENDED DATA UDTF=0010 <sub>2</sub>								
	7	6	5	4	3	2	1	0
Octet 0		Digit(4)		Digit(4)				
Octet 1		Digit(4)		Digit(4)				
Octet 2		Digit(4)		Digit(4)				
Octet 3		Digit(4)		Digit(4)				
Octet 4		Digit(4)		Digit(4)				
Octet 5		Digit(4)		Digit(4)				
Octet 6		Digit(4)		Digit(4)				
Octet 7		Digit(4)		Digit(4)				
Octet 8		Digit(4)		Digit(4)				
Octet 9		Digit(4)		Digit(4)				

APPENDED UDT #1

Figure B.7: Unified Data Transport Format (BCD) 1 digit to 20 digits

APPENDED DATA UDTF=0010 <sub>2</sub>								
	7	6	5	4	3	2	1	0
Octet 0	Digit(4)					Digit(4)		
Octet 1	Digit(4)					Digit(4)		
Octet 2	Digit(4)					Digit(4)		
Octet 3	Digit(4)					Digit(4)		
Octet 4	Digit(4)					Digit(4)		
Octet 5	Digit(4)					Digit(4)		
Octet 6	Digit(4)					Digit(4)		
Octet 7	Digit(4)					Digit(4)		
Octet 8	Digit(4)					Digit(4)		
Octet 9	Digit(4)					Digit(4)		
Octet 10	Digit(4)					Digit(4)		
Octet 11	Digit(4)					Digit(4)		

APPENDED UDT #1

APPENDED DATA UDTF=0010 <sub>2</sub>								
	7	6	5	4	3	2	1	0
Octet 0	Digit(4)					Digit(4)		
Octet 1	Digit(4)					Digit(4)		
Octet 2	Digit(4)					Digit(4)		
Octet 3	Digit(4)					Digit(4)		
Octet 4	Digit(4)					Digit(4)		
Octet 5	Digit(4)					Digit(4)		
Octet 6	Digit(4)					Digit(4)		
Octet 7	Digit(4)					Digit(4)		
Octet 8	Digit(4)					Digit(4)		
Octet 9	Digit(4)					Digit(4)		

APPENDED UDT #2

Figure B.8: Unified Data Transport Format (BCD) 21 digits to 44 digits

APPENDED DATA UDTF=0010 <sub>2</sub>								
	7	6	5	4	3	2	1	0
Octet 0	Digit(4)					Digit(4)		
Octet 1	Digit(4)					Digit(4)		
Octet 2	Digit(4)					Digit(4)		
Octet 3	Digit(4)					Digit(4)		
Octet 4	Digit(4)					Digit(4)		
Octet 5	Digit(4)					Digit(4)		
Octet 6	Digit(4)					Digit(4)		
Octet 7	Digit(4)					Digit(4)		
Octet 8	Digit(4)					Digit(4)		
Octet 9	Digit(4)					Digit(4)		
Octet 10	Digit(4)					Digit(4)		
Octet 11	Digit(4)					Digit(4)		

APPENDED UDT #1

APPENDED DATA UDTF=0010 <sub>2</sub>								
	7	6	5	4	3	2	1	0
Octet 0	Digit(4)					Digit(4)		
Octet 1	Digit(4)					Digit(4)		
Octet 2	Digit(4)					Digit(4)		
Octet 3	Digit(4)					Digit(4)		
Octet 4	Digit(4)					Digit(4)		
Octet 5	Digit(4)					Digit(4)		
Octet 6	Digit(4)					Digit(4)		
Octet 7	Digit(4)					Digit(4)		
Octet 8	Digit(4)					Digit(4)		
Octet 9	Digit(4)					Digit(4)		
Octet 10	Digit(4)					Digit(4)		
Octet 11	Digit(4)					Digit(4)		

APPENDED UDT #2

APPENDED DATA UDTF=0010 <sub>2</sub>								
	7	6	5	4	3	2	1	0
Octet 0	Digit(4)					Digit(4)		
Octet 1	Digit(4)					Digit(4)		
Octet 2	Digit(4)					Digit(4)		
Octet 3	Digit(4)					Digit(4)		
Octet 4	Digit(4)					Digit(4)		
Octet 5	Digit(4)					Digit(4)		
Octet 6	Digit(4)					Digit(4)		
Octet 7	Digit(4)					Digit(4)		
Octet 8	Digit(4)					Digit(4)		
Octet 9	Digit(4)					Digit(4)		

APPENDED UDT #3

Figure B.9: Unified Data Transport Format (BCD) 45 digits to 65 digits

APPENDED DATA UDTF=0010 <sub>2</sub>								
	7	6	5	4	3	2	1	0
Octet 0	Digit(4)					Digit(4)		
Octet 1	Digit(4)					Digit(4)		
Octet 2	Digit(4)					Digit(4)		
Octet 3	Digit(4)					Digit(4)		
Octet 4	Digit(4)					Digit(4)		
Octet 5	Digit(4)					Digit(4)		
Octet 6	Digit(4)					Digit(4)		
Octet 7	Digit(4)					Digit(4)		
Octet 8	Digit(4)					Digit(4)		
Octet 9	Digit(4)					Digit(4)		
Octet 10	Digit(4)					Digit(4)		
Octet 11	Digit(4)					Digit(4)		

APPENDED UDT #1

APPENDED DATA UDTF=0010 <sub>2</sub>								
	7	6	5	4	3	2	1	0
Octet 0	Digit(4)					Digit(4)		
Octet 1	Digit(4)					Digit(4)		
Octet 2	Digit(4)					Digit(4)		
Octet 3	Digit(4)					Digit(4)		
Octet 4	Digit(4)					Digit(4)		
Octet 5	Digit(4)					Digit(4)		
Octet 6	Digit(4)					Digit(4)		
Octet 7	Digit(4)					Digit(4)		
Octet 8	Digit(4)					Digit(4)		
Octet 9	Digit(4)					Digit(4)		
Octet 10	Digit(4)					Digit(4)		
Octet 11	Digit(4)					Digit(4)		

APPENDED UDT #2

APPENDED DATA UDTF=0010 <sub>2</sub>								
	7	6	5	4	3	2	1	0
Octet 0	Digit(4)					Digit(4)		
Octet 1	Digit(4)					Digit(4)		
Octet 2	Digit(4)					Digit(4)		
Octet 3	Digit(4)					Digit(4)		
Octet 4	Digit(4)					Digit(4)		
Octet 5	Digit(4)					Digit(4)		
Octet 6	Digit(4)					Digit(4)		
Octet 7	Digit(4)					Digit(4)		
Octet 8	Digit(4)					Digit(4)		
Octet 9	Digit(4)					Digit(4)		
Octet 10	Digit(4)					Digit(4)		
Octet 11	Digit(4)					Digit(4)		

APPENDED UDT #3

APPENDED DATA UDTF=0010 <sub>2</sub>								
	7	6	5	4	3	2	1	0
Octet 0	Digit(4)					Digit(4)		
Octet 1	Digit(4)					Digit(4)		
Octet 2	Digit(4)					Digit(4)		
Octet 3	Digit(4)					Digit(4)		
Octet 4	Digit(4)					Digit(4)		
Octet 5	Digit(4)					Digit(4)		
Octet 6	Digit(4)					Digit(4)		
Octet 7	Digit(4)					Digit(4)		
Octet 8	Digit(4)					Digit(4)		
Octet 9	Digit(4)					Digit(4)		

APPENDED UDT #4

Figure B.10: Unified Data Transport Format (BCD) 66 digits to 92 digits

### B.3.4 Appended Data ISO 7 bit character set Format

Appended data is coded ISO 7 bit character set (ISO/IEC 646 [11]). Up to four appended data UDTs may be concatenated with a UDT appended data header to form a multi-block UDT PDU. Up to 52 ISO 7 bit characters may be transported. The Pad Nibble information element in the UDT header specifies the number of 4 bit nibbles (1111<sub>2</sub>) that have been padded to the 7 bit character symbols to completely fill a block. An exact fit of pad nibbles is not always possible but there is sufficient indication to unambiguously specify the number of text symbols.

The number of user 7 bit character symbols, and the corresponding value of UAB and Pad Nibble is given by table B.4.

Table B.4: Relationship of ISO 7 bit symbols, UAB and Pad Nibble information elements

User 7 bit Symbols	UAB	Pad Nibble	User 7 bit Symbols	UAB	Pad Nibble	User 7 bit Symbols	UAB	Pad Nibble
1	0	18	19	1	10	37	2	3
2	0	16	20	1	9	38	2	1
3	0	14	21	1	7	39	3	23
4	0	13	22	1	5	40	3	22
5	0	11	23	1	3	41	3	20
6	0	9	24	1	2	42	3	18
7	0	7	25	1	0	43	3	16
8	0	6	26	2	22	44	3	15
9	0	4	27	2	20	45	3	13
10	0	2	28	2	19	46	3	11
11	0	0	29	2	17	47	3	9
12	1	23	30	2	15	48	3	8
13	1	21	31	2	13	49	3	6
14	1	19	32	2	12	50	3	4
15	1	17	33	2	10	51	3	2
16	1	16	34	2	8	52	3	1
17	1	14	35	2	6			
18	1	12	36	2	5			

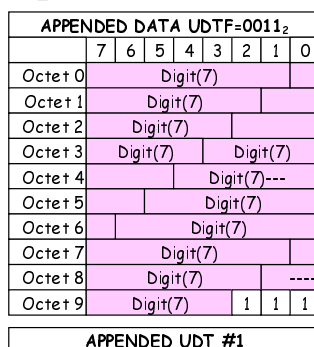

Figure B.11: Unified Data Transport Format (ISO 7 bit) 1 text symbol to 11 text symbols

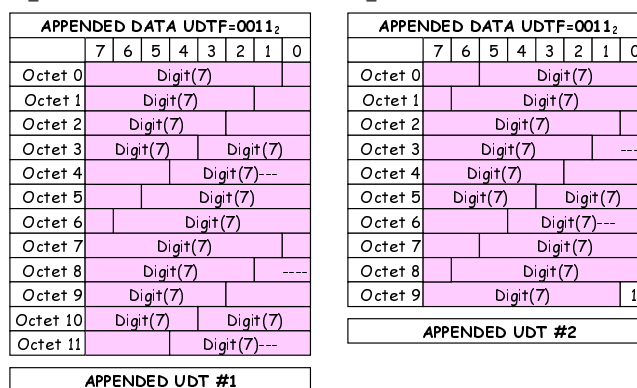

Figure B.12: Unified Data Transport Format (ISO 7 bit) 12 text symbols to 25 text symbols

APPENDED DATA UDTF=0011 <sub>2</sub>								
	7	6	5	4	3	2	1	0
Octet 0	Digit(7)							
Octet 1	Digit(7)							
Octet 2	Digit(7)							
Octet 3	Digit(7)			Digit(7)				
Octet 4	Digit(7)---							
Octet 5	Digit(7)							
Octet 6	Digit(7)							
Octet 7	Digit(7)							
Octet 8	Digit(7)							----
Octet 9	Digit(7)							
Octet 10	Digit(7)			Digit(7)				
Octet 11	Digit(7)---							
APPENDED UDT #1								

APPENDED DATA UDTF=0011 <sub>2</sub>								
	7	6	5	4	3	2	1	0
Octet 0	Digit(7)							
Octet 1	Digit(7)							
Octet 2	Digit(7)							
Octet 3	Digit(7)							----
Octet 4	Digit(7)							
Octet 5	Digit(7)			Digit(7)				
Octet 6	Digit(7)			Digit(7)---				
Octet 7	Digit(7)							
Octet 8	Digit(7)							
Octet 9	Digit(7)							
Octet 10	Digit(7)							
Octet 11	Digit(7)							
APPENDED UDT #2								

APPENDED DATA UDTF=0011 <sub>2</sub>								
	7	6	5	4	3	2	1	0
Octet 0	Digit(7)			Digit(7)				
Octet 1	Digit(7)---							
Octet 2	Digit(7)							
Octet 3	Digit(7)							
Octet 4	Digit(7)							
Octet 5	Digit(7)			Digit(7)				----
Octet 6	Digit(7)			Digit(7)				
Octet 7	Digit(7)			Digit(7)				
Octet 8	Digit(7)---							
Octet 9	Digit(7)							
Octet 10	Digit(7)							
Octet 11	Digit(7)							
APPENDED UDT #3								

Figure B.13: Unified Data Transport Format (ISO 7 bit) 26 text symbols to 38 text symbols

APPENDED DATA UDTF=0011 <sub>2</sub>								
	7	6	5	4	3	2	1	0
Octet 0	Digit(7)							
Octet 1	Digit(7)							
Octet 2	Digit(7)							
Octet 3	Digit(7)			Digit(7)				
Octet 4	Digit(7)---							
Octet 5	Digit(7)							
Octet 6	Digit(7)							
Octet 7	Digit(7)							
Octet 8	Digit(7)							----
Octet 9	Digit(7)							
Octet 10	Digit(7)			Digit(7)				
Octet 11	Digit(7)---							
APPENDED UDT #1								

APPENDED DATA UDTF=0011 <sub>2</sub>								
	7	6	5	4	3	2	1	0
Octet 0	Digit(7)							
Octet 1	Digit(7)							
Octet 2	Digit(7)							
Octet 3	Digit(7)							----
Octet 4	Digit(7)							
Octet 5	Digit(7)			Digit(7)				
Octet 6	Digit(7)			Digit(7)---				
Octet 7	Digit(7)							
Octet 8	Digit(7)							
Octet 9	Digit(7)							
Octet 10	Digit(7)							
Octet 11	Digit(7)							
APPENDED UDT #2								

APPENDED DATA UDTF=0011 <sub>2</sub>								
	7	6	5	4	3	2	1	0
Octet 0	Digit(7)			Digit(7)				
Octet 1	Digit(7)---							
Octet 2	Digit(7)							
Octet 3	Digit(7)							
Octet 4	Digit(7)							
Octet 5	Digit(7)			Digit(7)				
Octet 6	Digit(7)			Digit(7)				
Octet 7	Digit(7)			Digit(7)				
Octet 8	Digit(7)---							
Octet 9	Digit(7)							
Octet 10	Digit(7)							
Octet 11	Digit(7)							
APPENDED UDT #3								

APPENDED DATA UDTF=0011 <sub>2</sub>								
	7	6	5	4	3	2	1	0
Octet 0	Digit(7)							----
Octet 1	Digit(7)							
Octet 2	Digit(7)			Digit(7)				
Octet 3	Digit(7)---							
Octet 4	Digit(7)							
Octet 5	Digit(7)							
Octet 6	Digit(7)							
Octet 7	Digit(7)							
Octet 8	Digit(7)							
Octet 9	Digit(7)			Digit(7)				
Octet 10	Digit(7)							
Octet 11	Digit(7)							
APPENDED UDT #4								

Figure B.14: Unified Data Transport Format (ISO 7 bit) 39 text symbols to 52 text symbols

### B.3.5 Appended Data ISO 8 bit Character Format

Appended data is coded ISO 8 bit character format (ISO/IEC 8859 [12]). Up to four appended data UDTs may be concatenated with UDT appended data header to form a multi-block UDT PDU. Up to 46 ISO 8 bit characters may be transported. The Pad Nibble information element in the UDT header specifies the number of 4 bit nibbles (1111<sub>2</sub>) that have been padded to the Character symbols to completely fill a block.

The number of user 8 bit characters, and the corresponding value of UAB and Pad Nibble is given by table B.5.

Table B.5: Relationship of 8 bit character symbols, UAB and Pad Nibble information elements

User Character Symbols	UAB	Pad Nibble	User Character Symbols	UAB	Pad Nibble	User Character Symbols	UAB	Pad Nibble
1	0	18	17	1	10	33	2	2
2	0	16	18	1	8	34	2	0
3	0	14	19	1	6	35	3	22
4	0	12	20	1	4	36	3	20
5	0	10	21	1	2	37	3	18
6	0	8	22	1	0	38	3	16
7	0	6	23	2	22	39	3	14
8	0	4	24	2	20	40	3	12
9	0	2	25	2	18	41	3	10
10	0	0	26	2	16	42	3	8
11	1	22	27	2	14	43	3	6
12	1	20	28	2	12	44	3	4
13	1	18	29	2	10	45	3	2
14	1	16	30	2	8	46	3	0
15	1	14	31	2	6			
16	1	12	32	2	4			

APPENDED DATA UDTF=0100 <sub>2</sub>								
	7	6	5	4	3	2	1	0
Octet 0	Digit(8)							
Octet 1	Digit(8)							
Octet 2	Digit(8)							
Octet 3	Digit(8)							
Octet 4	Digit(8)							
Octet 5	Digit(8)							
Octet 6	Digit(8)							
Octet 7	Digit(8)							
Octet 8	Digit(8)							
Octet 9	Digit(8)							
APPENDED UDT #1								

Figure B.15: Unified Data Transport Format (8 bit character) 1 character symbol to 10 character symbols

APPENDED DATA UDTF=0100 <sub>2</sub>								
	7	6	5	4	3	2	1	0
Octet 0	Digit(8)							
Octet 1	Digit(8)							
Octet 2	Digit(8)							
Octet 3	Digit(8)							
Octet 4	Digit(8)							
Octet 5	Digit(8)							
Octet 6	Digit(8)							
Octet 7	Digit(8)							
Octet 8	Digit(8)							
Octet 9	Digit(8)							
Octet 10	Digit(8)							
Octet 11	Digit(8)							
APPENDED UDT #1								

APPENDED DATA UDTF=0100 <sub>2</sub>								
	7	6	5	4	3	2	1	0
Octet 0	Digit(8)							
Octet 1	Digit(8)							
Octet 2	Digit(8)							
Octet 3	Digit(8)							
Octet 4	Digit(8)							
Octet 5	Digit(8)							
Octet 6	Digit(8)							
Octet 7	Digit(8)							
Octet 8	Digit(8)							
Octet 9	Digit(8)							
APPENDED UDT #2								

Figure B.16: Unified Data Transport Format (8 bit character) 11 character symbols to 22 character symbols

APPENDED DATA UDTF=0100 <sub>2</sub>								
	7	6	5	4	3	2	1	0
Octet 0	Digit(8)							
Octet 1	Digit(8)							
Octet 2	Digit(8)							
Octet 3	Digit(8)							
Octet 4	Digit(8)							
Octet 5	Digit(8)							
Octet 6	Digit(8)							
Octet 7	Digit(8)							
Octet 8	Digit(8)							
Octet 9	Digit(8)							
Octet 10	Digit(8)							
Octet 11	Digit(8)							
APPENDED UDT #1								

APPENDED DATA UDTF=0100 <sub>2</sub>								
	7	6	5	4	3	2	1	0
Octet 0	Digit(8)							
Octet 1	Digit(8)							
Octet 2	Digit(8)							
Octet 3	Digit(8)							
Octet 4	Digit(8)							
Octet 5	Digit(8)							
Octet 6	Digit(8)							
Octet 7	Digit(8)							
Octet 8	Digit(8)							
Octet 9	Digit(8)							
Octet 10	Digit(8)							
Octet 11	Digit(8)							
APPENDED UDT #2								

APPENDED DATA UDTF=0100 <sub>2</sub>								
	7	6	5	4	3	2	1	0
Octet 0	Digit(8)							
Octet 1	Digit(8)							
Octet 2	Digit(8)							
Octet 3	Digit(8)							
Octet 4	Digit(8)							
Octet 5	Digit(8)							
Octet 6	Digit(8)							
Octet 7	Digit(8)							
Octet 8	Digit(8)							
Octet 9	Digit(8)							
APPENDED UDT #3								

Figure B.17: Unified Data Transport Format (8 bit character) 23 character symbols to 34 character symbols

APPENDED DATA UDTF=0100 <sub>2</sub>								
	7	6	5	4	3	2	1	0
Octet 0	Digit(8)							
Octet 1	Digit(8)							
Octet 2	Digit(8)							
Octet 3	Digit(8)							
Octet 4	Digit(8)							
Octet 5	Digit(8)							
Octet 6	Digit(8)							
Octet 7	Digit(8)							
Octet 8	Digit(8)							
Octet 9	Digit(8)							
Octet 10	Digit(8)							
Octet 11	Digit(8)							
APPENDED UDT #1								

APPENDED DATA UDTF=0100 <sub>2</sub>								
	7	6	5	4	3	2	1	0
Octet 0	Digit(8)							
Octet 1	Digit(8)							
Octet 2	Digit(8)							
Octet 3	Digit(8)							
Octet 4	Digit(8)							
Octet 5	Digit(8)							
Octet 6	Digit(8)							
Octet 7	Digit(8)							
Octet 8	Digit(8)							
Octet 9	Digit(8)							
Octet 10	Digit(8)							
Octet 11	Digit(8)							
APPENDED UDT #2								

APPENDED DATA UDTF=0100 <sub>2</sub>								
	7	6	5	4	3	2	1	0
Octet 0	Digit(8)							
Octet 1	Digit(8)							
Octet 2	Digit(8)							
Octet 3	Digit(8)							
Octet 4	Digit(8)							
Octet 5	Digit(8)							
Octet 6	Digit(8)							
Octet 7	Digit(8)							
Octet 8	Digit(8)							
Octet 9	Digit(8)							
Octet 10	Digit(8)							
Octet 11	Digit(8)							
APPENDED UDT #3								

APPENDED DATA UDTF=0100 <sub>2</sub>								
	7	6	5	4	3	2	1	0
Octet 0	Digit(8)							
Octet 1	Digit(8)							
Octet 2	Digit(8)							
Octet 3	Digit(8)							
Octet 4	Digit(8)							
Octet 5	Digit(8)							
Octet 6	Digit(8)							
Octet 7	Digit(8)							
Octet 8	Digit(8)							
Octet 9	Digit(8)							
APPENDED UDT #4								

Figure B.18: Unified Data Transport Format (8 bit character) 35 character symbols to 46 character symbols

### B.3.6 Appended Data NMEA (IEC 61162-1) format

Appended data is with essential data elements for NMEA formatted (IEC 61162-1 [8]) coordinates. Up to two appended data UDTs may be concatenated with a UDT appended data header to form a multi-block UDT PDU. Three formats are described, a short NMEA format where the NMEA data is contained in one appended UDT, and a long format where two appended blocks either enable additional NMEA data to be carried or permit manufacturers to implement a customized format.

For the NMEA format UDT the Pad Nibble information element in the UDT header shall be set to 0 0000<sub>2</sub>). If the appended blocks represent the Short NMEA format then UAB in the UDT header shall be set to 00<sub>2</sub>). If the appended blocks represent the long specified NMEA format then UAB shall be set to 01<sub>2</sub>). If the appended blocks represent the long unspecified NMEA format then UAB shall be set to 10<sub>2</sub>). The information elements for the appended blocks are described in table B.7.

Table B.6 specifies the value of UAB and Pad Nibble.

Table B.6 Relationship of NMEA format and UAB

NMEA Format	UAB	Pad Nibble
Short Format	00 <sub>2</sub>	0
Long Format (format specified)	01 <sub>2</sub>	0
Long Format (format unspecified)	10 <sub>2</sub>	0
Reserved	11 <sub>2</sub>	0

### B.3.6.1 Short NMEA (IEC 61162-1) format

UAB in the UDT header is set to 00<sub>2</sub>. The NMEA data is carried in one appended UDT. The UTCss3 information element carries the time in increments of 10 seconds.

APPENDED DATA UDTF=0101 <sub>2</sub>								
	7	6	5	4	3	2	1	0
Octet 0	C	NS	EW	Q	SPEED(7)---			
Octet 1	---			NDEG(7)---				
Octet 2	---							NMIN(6)
Octet 3	NMINF(14)---							
Octet 4	-----							---
Octet 5	---EDEG(8)							--
Octet 6	--EMINmm(6)							---
Octet 7	----EMINF(14)----							
Octet 8	---			UTChh(5)		-		
Octet 9	UTCmm(6)			UTCss3(3)				
APPENDED UDT #1								

Figure B.19: Appended Data Short NMEA format

### B.3.6.2 Long NMEA (IEC 61162-1) format specified

UAB in the UDT header is set to 01<sub>2</sub>. The NMEA data is carried in two appended UDTs. The UTCss6 information element carries the time in increments of 1 second. MFID is set to SFID (0000 0000<sub>2</sub>).

APPENDED DATA UDTF=0101 <sub>2</sub>								
	7	6	5	4	3	2	1	0
Octet 0	C	NS	EW	Q	SPEED(7)---			
Octet 1	---			NDEG(7)---				
Octet 2	---							NMIN(6)
Octet 3	NMINF(14)---							
Octet 4	-----							---
Octet 5	---EDEG(8)							--
Octet 6	--EMINmm(6)							---
Octet 7	----EMINF(14)----							
Octet 8	---			UTChh(5)		-		
Octet 9	UTCmm(6)			UTCss6(6)				
Octet 10	---							Spare(5)
Octet 11	Spare(8)							
APPENDED UDT #1								

APPENDED DATA UDTF=0101 <sub>2</sub>								
	7	6	5	4	3	2	1	0
Octet 0	Spare(7)							---
Octet 1	---COG(9)							
Octet 2	SPARE(64)							
Octet 3								
Octet 4								
Octet 5								
Octet 6								
Octet 7								
Octet 8								
Octet 9								
APPENDED UDT #2								

Figure B.20: Appended Data Long NMEA format specified

### B.3.6.3 Long NMEA (IEC 61162-1) format unspecified

UAB in the UDT header is set to 10<sub>2</sub>. The NMEA data is carried in two appended UDTs. MFID is set to the manufacturers FID.

APPENDED DATA UDTF=0101 <sub>2</sub>								
	7	6	5	4	3	2	1	0
Octet 0	SPARE(88)							
Octet 1								
Octet 2								
Octet 3								
Octet 4								
Octet 5								
Octet 6								
Octet 7								
Octet 8								
Octet 9								
Octet 10								
Octet 11	MFID(8)							
APPENDED UDT #1								

APPENDED DATA UDTF=0101 <sub>2</sub>								
	7	6	5	4	3	2	1	0
Octet 0	SPARE(80)							
Octet 1								
Octet 2								
Octet 3								
Octet 4								
Octet 5								
Octet 6								
Octet 7								
Octet 8								
Octet 9								
APPENDED UDT #2								

Figure B.21: Appended Data Long NMEA format unspecified



Table B.7: Appended Data NMEA Elements

Alias	Length	Value	Description
C	1	0	Data is not encrypted
		1	Data is encrypted
NS	1	0	Latitude Direction - South
		1	Latitude Direction - North
EW	1	0	Longitude Direction - West
		1	Longitude Direction - East
Q	1	0	GPS Quality Indicator - No fix
		1	GPS Quality Indicator - Fix Valid
SPEED	7		Speed in knots (0 to 126) 127 = greater than 126 knots
NDEG	7		Latitude Degrees (00 to 89)
NMINmm	6		Latitude Minutes (00 to 59)
NMINF	14		Latitude Fractions of minutes (0000 to 9999)
EDEG	8		Longitude Degrees (000 to 179)
EMINmm	6		Longitude Minutes (00 to 59)
EMINF	14		Longitude Fractions of minutes (0000 to 9999)
UTCCh	5		UTC time hours (00 to 23)
UTCmm	6		UTC time minutes (00 to 59)
UTCss3	3		UTC time 10's seconds ([0 to 5] x 10)
UTCss6	6		UTC time seconds (00 to 59)
DOP	5		Dilution of Precision (1 to 31)
COG	9		Course over ground in degrees (0 to 359)
Spare			Freely Available for manufacturers
MFID	8		Manufacturers Feature Set ID (see TS 102 361-1 [5] annex H)

### B.3.7 UDT DMR IP format

The UDT IP format is illustrated in figures B.22 and B.23.

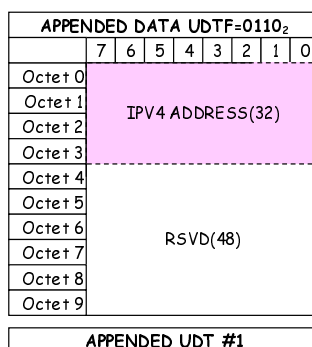

Figure B.22: Appended Data IPV4 format

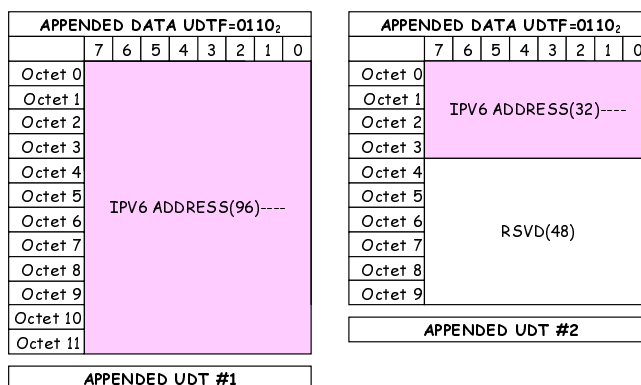

Figure B.23: Appended Data IPv6 format

### B.3.8 Appended Data Unicode 16 bit UTF-16BE Character Format

Appended data is coded UTF-16BE Unicode (IEC 61162-1 [8]) 16 bit character format. Up to four appended data UDTs may be concatenated with UDT appended data header to form a multi-block UDT PDU. Up to 23 Unicode characters may be transported. The Pad Nibble information element in the UDT header specifies the number of 4 bit nibbles ( $1111_2$ ) that have been padded to the Unicode Characters to completely fill a block.

The number of user ISO 7 bit symbols, and the corresponding value of UAB and Pad Nibble is given by table B.8.

**Table B.8: Relationship of 16 bit Unicode Character symbols, UAB and Pad Nibble information elements**

User Character Symbols	UAB	Pad Nibble	User Character Symbols	UAB	Pad Nibble	User Character Symbols	UAB	Pad Nibble
1	0	16	9	1	8	17	2	0
2	0	12	10	1	4	18	3	20
3	0	8	11	1	0	19	3	16
4	0	4	12	2	20	20	3	12
5	0	0	13	2	16	21	3	8
6	1	20	14	2	12	22	3	4
7	1	16	15	2	8	23	3	0
8	1	12	16	2	4			

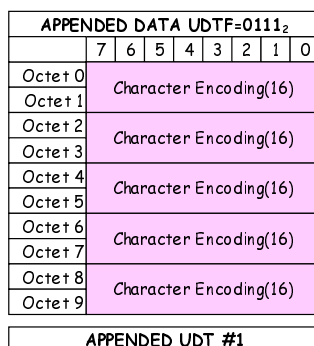

**Figure B.24: Unified Data Transport Format (16 bit character) 1 character symbol to 5 character symbols**



## Annex C (informative): Physical Channel Plan

### C.1 Transmission and Reception

#### C.1.1 RF carriers

##### C.1.1.1 Nominal carriers frequencies

The nominal carrier frequencies for DMR may be allocated in any of the frequency bands in the range 50 MHz to 999 MHz. Upper layers of the protocol stack define a single logical channel number that equates to a transmitter and receiver frequencies in the range 1 to 4 094. Since the DMR Standard supports re-assigning of existing analogue channels, flexibility may be provided where prescribed channel plans are suitable.

DMR may therefore support:

- a number of fixed channel plans where the MS transmit frequency, the split between transmit and receive, the channel separation and if the receiver is high or low relative to the transmitter;
- a flexible channel plan whereby each logical channel may represent a transmitter and receiver frequency pair;
- a broadcast PDU that enables the TSCC to announce a logical / physical transmitter and receiver relationship;
- an extended channel grant PDU that specifies the physical transmitter and receiver frequencies.

The higher DMR layers only have the logical CHAN SDU to define the physical frequencies. The additional parameters (type of channel plan, Tx/Rx separation, etc.) exist in the physical layer only and are programmed during personalization or manufacture of the equipment. A National Administration may mandate certain limitations on particular frequencies (such as transmitter power).

##### C.1.1.2 Fixed Channel Plan

The nominal MS Tx frequency  $f_{MS\_Tx}$  corresponds to its logical carrier number, CHAN, which is defined as:

$f_{MS\_Tx}$  - MS transmit frequency (MHz)

$f_{base}$  - The lowest frequency in a particular band relating to logical CHAN=1 (MHz)

$f_{separation}$  - The frequency separation between two adjacent channels (kHz)

$f_{duplexsplit}$  - The difference between MS Tx and MS Rx [for clarity MS Tx minus MS Rx] ( $\pm$ MHz)

$f_{MS\_Tx} = f_{base} + ((CHAN-1) \times (f_{separation}/1\ 000))$  MHz

$f_{MS\_Rx} = f_{MS\_Tx} \pm f_{duplexsplit}$  MHz

$f_{duplexsplit} = 0$  MHz to 50 MHz in 2,5 kHz steps

$f_{separation}$  - Definition

**Table C.1: Frequency Separation**

SDU Code (SEP)	Separation (kHz)
0000 <sub>2</sub>	5
0001 <sub>2</sub>	6,25
0010 <sub>2</sub>	10
0011 <sub>2</sub>	12,5
0100 <sub>2</sub>	15
0101 <sub>2</sub>	20
0110 <sub>2</sub>	25
0111 <sub>2</sub>	30
1xxx <sub>2</sub>	reserved

$f_{\text{split}}$  - The difference between MS Tx and MS Rx [for clarity MS Tx minus MS Rx] ( $\pm$ MHz)

**Table C.2: Frequency Split high/low**

SDU Code (TXRX_SPLIT)	
0 <sub>2</sub>	MS Tx is high of MS Rx
1 <sub>2</sub>	MS Tx is low of MS Rx

$f_{\text{duplexsplit}}$  - Definition

**Table C.3: Frequency Split**

SDU Code (DUPLEX_SPLIT)	Duplex Split (kHz)
000 0000 0000 0000 <sub>2</sub>	0
000 0000 0000 0001 <sub>2</sub>	2,5
.....	
000 0111 0011 0000 <sub>2</sub>	4 600 (4,6 MHz)
.....	
000 1100 1000 0000 <sub>2</sub>	8 000 (8 MHz)
.....	
000 1111 1010 0000 <sub>2</sub>	10 000 (10 MHz)
.....	
100 0110 0101 0000 <sub>2</sub>	45 000 (45 MHz)

$f_{\text{base}}$  - Band Definition

**Table C.4: Band Definition**

SDU Code (BAND)	$f_{\text{base}}$ MHz
000 0011 <sub>2</sub>	30
000 0100 <sub>2</sub>	40
000 0101 <sub>2</sub>	50
000 0110 <sub>2</sub>	60
000 0111 <sub>2</sub>	70
.....	
010 1101 <sub>2</sub>	450
.....	
101 0000 <sub>2</sub>	800
110 0100 <sub>2</sub>	1 000

chan - Logical Channel Numbers

**Table C.5: Logical Channel Numbers**

Channel Number	SDU Code (CHAN)	Colour Code (see note)
1	0000 0000 0001 <sub>2</sub>	Value
.....		.....
4 094	1111 1111 1110 <sub>2</sub>	Value
NOTE: The default colour code =0000 <sub>2</sub> .		

### C.1.1.3 Flexible Channel Plan

Each logical channel number has the transmitter and receiver frequency defined.

**Table C.6: Flexible Channel Plan**

Channel Number	SDU Code (CHAN)	Transmitter Frequency	Receiver Frequency	Colour Code (see note)
1	0000 0000 0001 <sub>2</sub>			Value
.....				.....
4 094	1111 1111 1110 <sub>2</sub>			Value
NOTE: The default colour code =0000 <sub>2</sub> .				

### C.1.1.4 Determination of Transmitter and Receiver frequency from CdefParms

The MS absolute transmitter and receiver frequency is defined in 125 Hz steps as illustrated in table C.7.

**Table C.7: Absolute Transmitter and Receiver SDUs**

ALIAS	SDU Code	Transmitter/Receiver Frequency
TXMHz	00 0011 0010 <sub>2</sub>	50 MHz
RXMHz	11 1110 0111 <sub>2</sub>	999 MHz
TXKHz RXKHz	0 0000 0000 0000 <sub>2</sub>	0 Hz
	0 0000 0000 0001 <sub>2</sub>	+125 Hz
	0 0000 0000 0010 <sub>2</sub>	+250 Hz
	1 1111 0011 1111 <sub>2</sub>	+999 875 Hz

The absolute transmitter frequency (MHz) = TXMHz + (TXKHz × 125)/1 000.

The absolute receiver frequency (MHz) = RXMHz + (RXKHz × 125)/1 000.

---

# Annex D (informative): Control Channel Hunting Procedures

## D.1 Introduction

In order to locate a valid TSCC, the MS hunts through a list candidate physical channels until an appropriate TSCC is selected and confirmed. This TSCC hunting may involve a variety of hunting sequences depending on the circumstances of the hunt. This annex shows a framework for MS hunting strategy.

Since two logical TDMA channels occupy one physical channel, the MS can appraise both logical channels concurrently when sampling a physical channel. The MS may use information from the CACH or PDUs that contain a C\_SYSCode information element to use for verification tests specified in clause 6.3.2.2.1.

The Control Channel Hunting Procedure stages are:

- a) The "resuming a TSCC hunt channel" allows an MS, after a period of activity on a payload physical channel, to resume the TSCC on which it was last confirmed prior to the payload Channel Grant PDU.
- b) The "commanded TSCC hunt channel" is employed when a MS is directed on the TSCC to a particular TSCC (from a C\_MOVE or P\_CLEAR PDU) or seeks to regain a TSCC after a period of inactivity on the selected network (due to being switched off or a user-initiated change of selected network when details of the last confirmed TSCC number have been stored by the MS in non-volatile storage).
- c) "Short Hunt Sequence": A hunting sequence, which samples all physical channel numbers likely to be employed as TSCCs by the selected network. A list of Nmax\_Ch likely logical candidate physical channel numbers is held in MS fixed non-volatile storage for the selected network. The MS should have the storage for up to 64 values of the logical physical channel number information element defining the extent of the "short hunt sequence". Unused storage locations are marked such that the MS may ignore them. Particular Physical channel numbers may be stored in the list numerous times to provide a bias to that particular TSCC.
- d) "Comprehensive Hunt Sequence". A hunting sequence, that samples all possible physical channel numbers in use by the network. This hunting sequence provides a contingency to allow TSCCs to be acquired even when physical channel numbers not normally employed for this purpose are in use. The "comprehensive hunt sequence" may be temporarily suspended to sample likely physical channels or repeat a "short hunt sequence". The lowest Low\_Comp\_Ch and highest High\_Comp\_Ch is held in the MS fixed non-volatile storage.

NOTE 1: The "Comprehensive Hunt Sequence" may be suppressed by network personalization.

When carrying out a "resuming a TSCC hunt channel" or "commanded TSCC hunt channel" the hunting procedure is considered complete when the MS has tuned directly to the physical channel and has carried out the appropriate verification and confirmation procedures specified in clause 6.3.

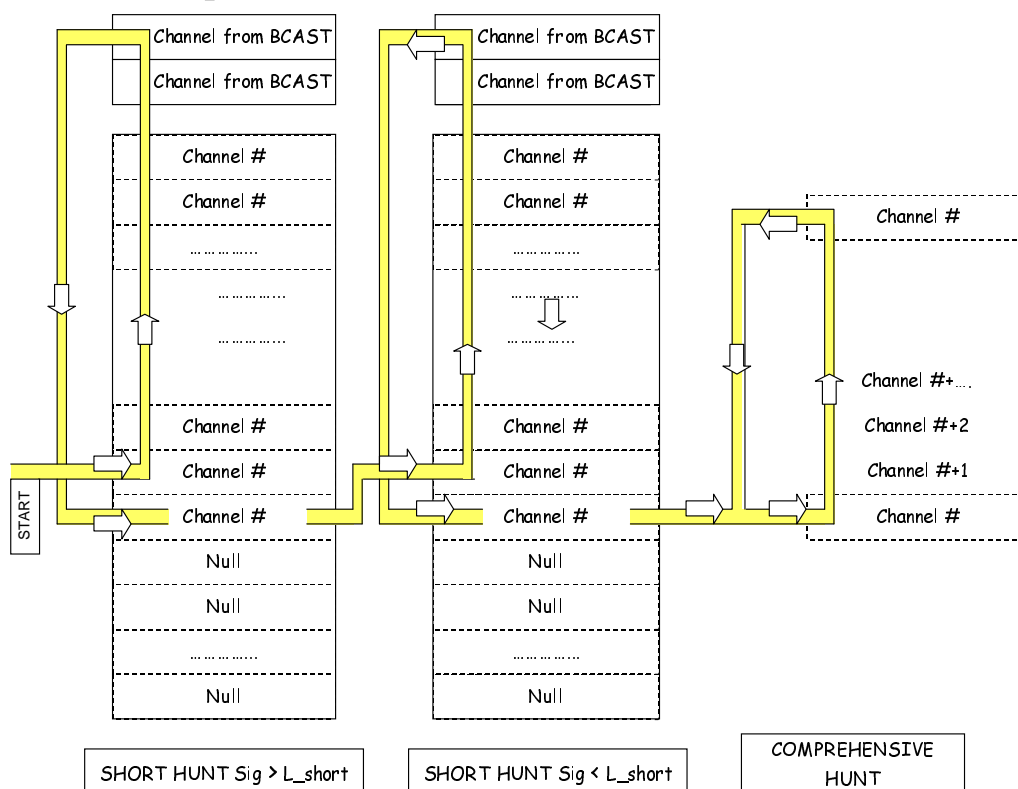

**Figure D.1: Physical Channel Hunting**

Figure D.1 shows a possible implementation of the "Short Hunt Sequence" and "Comprehensive Hunt" Sequence. If the MS needs to search for an appropriate TSCC, this process searches the most likely physical channel candidates first. This example of a possible implementation carries out the short hunt twice, the first loop being exercised looking for a TSCC whose signal strength exceeds a defined value ( $L_{SigShort}$ ).

A hunting sequence may be considered complete when either:

- a physical channel is found that satisfies the TSCC verification and confirmation tests specified in clause 6.3. (The hunting procedure was successful);
- all physical channel numbers within the scope of the hunting sequence have been tested without a physical channel being found which satisfies the TSCC confirmation tests specified in clause 6.3 (the hunting sequence failed).

The MS carries out the hunting procedure in the order described in this clause. If a hunting sequence is unsuccessfully completed, then the MS starts the next hunting sequence. The final hunting sequence is the "comprehensive hunt sequence". If this hunting sequence cannot be completed, the MS stays in this hunting sequence until a TSCC is confirmed. However, the foregoing provisions of this clause may be relaxed in the following circumstances:

- the "comprehensive hunt sequence" may be suppressed by MS personalization for a network;
- a MS in a "comprehensive hunt sequence" may elect to perform complete hunting sequences of any other type, returning to the "comprehensive hunt sequence" in the event of failure to confirm an appropriate TSCC;
- a MS may elect to sample any physical channel that may satisfy the TSCC verification and confirmation tests specified in clause 6.3.

Where a hunting stage involves more than one physical channel the order in which physical channels are sampled is not specified. However, in order to guard against bias towards certain physical channels, MSs should ensure randomness in the order in which physical channels are sampled by one of the following:

- hunting physical channel numbers sequentially (e.g. from lowest to highest number) but beginning the hunting stage at a random position in the sequence of physical channel numbers;
- hunting physical channel numbers in a random fashion.



The procedures defined in the present document are intended to provide a comprehensive range of methods that may be used as a basis for the design of MSs.

NOTE 2: The specified mechanism is a framework for MSs. The use of additional or differing procedures is not prohibited provided that they satisfy the verification and confirmation procedures defined in the present document.

EXAMPLE: A MS locating a physical channel which satisfies the TSCC confirmation tests specified in clause 6.3 may continue the hunt in anticipation that an alternative TSCC may be found with a higher received signal quality or level. Also, MSs need not limit the hunting procedures to the receiver sensitivity threshold levels specified and may conduct additional hunts at other levels.

## D.1.1 Resuming a TSCC hunt channel

When "resuming a TSCC hunt channel" the MS retunes to the logical physical channel number of the TSCC on which it was last confirmed. The MS should be capable of receiving on the TSCC outbound channel, which it is resuming within two TDMA-frames of the following instants:

- a) the end of any P\_CLEAR PDU, which requires the MS to cease activity on the payload channel to which it is currently tuned;
- b) the end of the last payload disconnect PDU P\_MAINT (Maint\_Kind=DISCON) sent by the MS on a payload channel;
- c) the end of any call authorization check PDU (P\_AUTH) received on a payload channel where the MS address information element in the P\_AUTH PDU does NOT match one of the addresses from the Channel Grant PDU that directed the MS to the payload channel;
- d) the operation of the any user initiated "call end request" by the user during a talkgroup call when the MS was not the call originator of the call.

Before confirming the TSCC the MS should verify any C\_SYSCode received on the channel in accordance with the procedures of clause 6.3.2.2.1. In the event of the C\_SYSCode fails the verification procedures, the hunting sequence is considered unsuccessfully completed and the MS enters the "short hunt sequence".

## D.1.2 Commanded TSCC hunt channel

### D.1.2.1 Conditions to enter a Commanded TSCC hunt

A "single channel hunt" applies when the MS is directed to a TSCC other than the one on which it was last confirmed, or when it is switched on whilst still retaining valid network information from previous activity on the selected network, or the user initiates a change of selected network and the MS still retains valid information of previous activity on the new selected network. The MS should be able to receive the nominated physical channel within 3 TDMA slots of the following instants:

- a) the end of any valid C\_MOVE PDU that is applicable to the MS;
- b) the MS being switched on, provided that the unit holds a valid record of the channel number on which the MS was most recently confirmed;
- c) a change of selected network being initiated by the user, provided that the MS holds a valid record of the channel number on which the MS was most recently confirmed on the new selected network.

### D.1.2.2 Nominated Channel for the Single Channel Hunt

The nominated channel is:

- a) the logical physical channel number indicated in the CONT information element of the P\_CLEAR PDU; or
- b) the channel number indicated in the CONT information element the C\_MOVE PDU; or
- c) the channel number held in the MSs read/write storage as the TSCC on which the unit was most recently confirmed on the selected network.

The MS does not make any transmissions on a TSCC until it has confirmed the channel in accordance with the procedure specified in clause 6.3. In the event of a failure of the TSCC to meet the channel confirmation criteria the hunting sequence is considered unsuccessfully completed. Upon unsuccessful completion of the "commanded TSCC hunt channel" the MS enters the "short hunt sequence".

### D.1.2.3 Short Hunt Sequence

A "Short Hunt Sequence" samples all physical channels most likely to be employed as TSCCs by the selected network. There are many strategies that may be employed but all strategies search from a shortlist of candidates as follows:

- a) A list of likely physical channels will be specified by an external agency stored in MS fixed non-volatile storage.
- b) The MS may modify the scope of the shortlist of physical channels from information broadcast from the network and held in its non-volatile storage as follows:
  - 1) by adding to the compass of the hunting sequence channel numbers received in C\_BCAST (Announce/Withdraw) PDU from the selected network;
  - 2) by removing from the compass of the hunting sequence channel numbers received in C\_BCAST (Announce/Withdraw) PDUs from the selected network.

One strategy illustrated in figure D.1 entails hunting the list of physical channel numbers sequentially (e.g. from the randomly chosen list position to the highest then circling to the lowest list position) but beginning the hunting stage at a random position in the sequence of physical channel numbers. The shortlist is sampled twice, the first loop being exercised looking for a TSCC whose signal strength exceeds a defined value (L\_Short).

Another possible strategy entails hunting the complete shortlist of physical channel numbers sequentially (e.g. from lowest list position to highest list position) recording the signal strength and/or BER. After sampling all channels in the list the MS chooses the most appropriate TSCC.

#### D.1.2.3.1 Conditions to enter a Short Channel Hunt

A MS enters the "short hunt sequence":

- a) immediately after switch-on, provided that the MS holds no valid information of previous activity on the selected network;
- b) when the user indicates a change of selected network, provided that the MS holds no valid information of previous activity on the selected network.

The MS may enter the "short hunt sequence" at any time during the "comprehensive hunt sequence", at the MSs discretion.

The MS should not make any transmissions on a TSCC located during the "short hunt sequence" until it has verified and confirmed the channel in accordance with the procedures specified in clause 6.3.

Upon unsuccessful completion of the "short hunt sequence" the MS enters the "comprehensive hunt sequence", except when the "comprehensive hunt sequence" has been suppressed by MS personalization for a network.

## D.1.2.4 Comprehensive Hunt Sequence

The "comprehensive hunt sequence" includes every channel within the range set by the lowest and highest channel numbers set by the network personalization, held in the MSs fixed non-volatile storage.

### D.1.2.4.1 Conditions to enter a Comprehensive Channel Hunt

A MS enters the "comprehensive hunt sequence" when a "short hunt sequence" has been unsuccessfully completed.

A MS may repeat the "comprehensive hunt stage" until such a time as a physical channel which satisfies the TSCC confirmation tests specified in clause 6.3 is found.

The MS does not make any transmissions on a TSCC located during the "comprehensive hunt sequence" until it has confirmed the channel in accordance with the procedures specified in clause 6.3.

At any time during the "comprehensive hunt sequence" a MS may undertake a "short hunt sequence", or sample any physical channels that the MS is able to determine may be successful, returning to the "comprehensive hunt sequence" in the event that these choices is unsuccessful.

It is possible to suppress the "comprehensive hunt sequence" by MS network personalization. In this case the MS remains in the "short hunt sequence" with the acquisition threshold set to a level  $L_{\text{Squelch}}$  until such time as a channel which satisfies the TSCC confirmation tests specified in clause 6.3.

## D.1.2.5 Receiver Sensitivity During Control Channel Acquisition

The MS should not attempt to become active on any physical channel for which the received signal level (or signal quality) is less than the specified acquisition threshold.

The acquisition threshold  $L_{\text{Short}}$  is set to a signal level within the range  $L_{\text{Upper\_Short}}$  to  $L_{\text{Lower\_Short}}$  at the input of the receiver (or an equivalent if the receiver measures signal quality).

$L_{\text{Squelch}}$  is set at a level determined by the MS manufacturer which enables unsuitable physical channels to be rejected on which the received signal is inadequate for a suitable grade of service (or an equivalent if the receiver measures signal quality).

NOTE: The MS may be unable to determine the received signal level but may use other methods such as bit error measurements to determine the signal quality.

## Annex E (informative): Use of MSC and SDL diagrams

### E.1 Introduction

The present document makes use of SDL and MSC diagrams to complement textual behaviour descriptions in DMR Part Trunking Services and Facilities Protocol.

### E.2 Principle

The MSC and SDL diagrams express the same behaviour (requirement) as defined by the textual description so they only complement the textual description in order to provide an alternative perspective on a requirement. The development of these diagrams also may support validation of the textual description, e.g. identifying missing stop of a timer when other expected behaviour occurs before timeout.

### E.3 Notation

The MSC-diagrams make use of the following constructs illustrated in figure E.1.

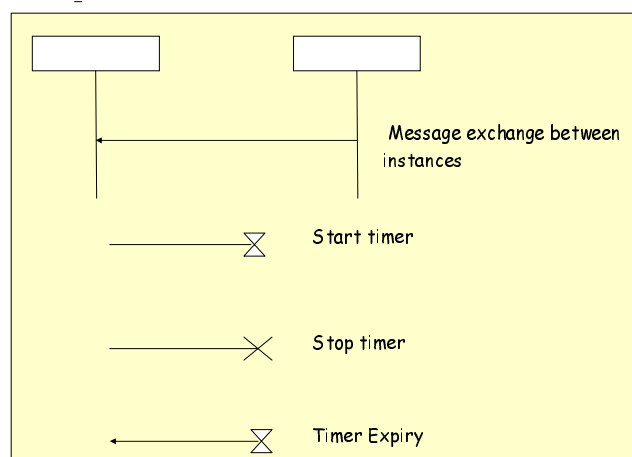

**Figure E.1: SDL Notation**

- 1) Message exchange between instances (line with arrow associated with message name and parameters in parentheses).
- 2) Start timer (horizontal line with hour-glass).
- 3) Stop timer, (horizontal line with 'x').
- 4) Timeout (horizontal line with arrow and hour-glass).
- 5) The optional inline construct, (rectangle with keyword 'opt' in upper left corner). The meaning of the optional inline construct is that the contained behaviour is optional to occur.
- 6) The alternative inline construct (rectangle with keyword 'alt' in upper left corner and dotted separation lines). The meaning of this construct is that each of the alternatives divided by the dotted line is a possible behaviour of which exactly one is to occur for the MSC.

In the SDL diagrams only basic process behaviour symbols are used, that is state, input, output, decision, timer start, and timer stop symbols.

---

## Annex F (informative): Bibliography

ETSI TR 102 335-2: "Electromagnetic compatibility and Radio spectrum Matters (ERM); System reference document for harmonized use of Digital Mobile Radio (DMR); Part 2: Systems operating under individual licences in the existing land mobile service spectrum bands".

---

## History

<b>Document history</b>		
V1.1.1	January 2006	Publication
V1.2.1	September 2006	Publication
V1.3.1	June 2010	Publication
V1.4.1	January 2012	Publication
V1.5.1	February 2013	Publication
V1.6.1	June 2014	Publication