

# ETSI TS 102 349 V3.1.1 (2010-12)

---

*Technical Specification*

## Digital Radio Mondiale (DRM); Receiver Status and Control Interface (RSCI)

---



**EBU-UER**



---

Reference

RTS/JTC-DRM-25

---

Keywords

broadcasting, control, digital, DRM, interface,  
remote

**ETSI**

650 Route des Lucioles  
F-06921 Sophia Antipolis Cedex - FRANCE

Tel.: +33 4 92 94 42 00 Fax: +33 4 93 65 47 16

Siret N° 348 623 562 00017 - NAF 742 C  
Association à but non lucratif enregistrée à la  
Sous-Préfecture de Grasse (06) N° 7803/88

---

**Important notice**

Individual copies of the present document can be downloaded from:

<http://www.etsi.org>

The present document may be made available in more than one electronic version or in print. In any case of existing or perceived difference in contents between such versions, the reference version is the Portable Document Format (PDF). In case of dispute, the reference shall be the printing on ETSI printers of the PDF version kept on a specific network drive within ETSI Secretariat.

Users of the present document should be aware that the document may be subject to revision or change of status. Information on the current status of this and other ETSI documents is available at

<http://portal.etsi.org/tb/status/status.asp>

If you find errors in the present document, please send your comment to one of the following services:

[http://portal.etsi.org/chaicor/ETSI\\_support.asp](http://portal.etsi.org/chaicor/ETSI_support.asp)

---

**Copyright Notification**

No part may be reproduced except as authorized by written permission.  
The copyright and the foregoing restriction extend to reproduction in all media.

© European Telecommunications Standards Institute 2010.

© European Broadcasting Union 2010.

All rights reserved.

**DECT**<sup>™</sup>, **PLUGTESTS**<sup>™</sup>, **UMTS**<sup>™</sup>, **TIPHON**<sup>™</sup>, the TIPHON logo and the ETSI logo are Trade Marks of ETSI registered for the benefit of its Members.

**3GPP**<sup>™</sup> is a Trade Mark of ETSI registered for the benefit of its Members and of the 3GPP Organizational Partners.

**LTE**<sup>™</sup> is a Trade Mark of ETSI currently being registered for the benefit of its Members and of the 3GPP Organizational Partners.

**GSM**<sup>®</sup> and the GSM logo are Trade Marks registered and owned by the GSM Association.

# Contents

Intellectual Property Rights .....	5
Foreword.....	5
Introduction .....	5
1 Scope .....	6
2 References .....	6
2.1 Normative references .....	6
2.2 Informative references.....	6
3 Definitions, symbols, abbreviations and convention.....	6
3.1 Definitions .....	6
3.2 Symbols.....	8
3.3 Abbreviations .....	9
3.4 Convention .....	10
4 System conception for DRM coverage monitoring.....	11
5 Protocols, profiles and rules .....	12
5.1 Protocols.....	12
5.2 Profiles .....	12
5.2.1 Standard Profiles.....	13
5.2.2 User-defined profiles .....	15
5.3 Timing .....	15
5.3.1 Short interleaving (robustness modes A to D).....	15
5.3.2 Long interleaving (robustness modes A to D).....	16
5.3.3 Fixed interleaving (robustness mode E).....	17
5.4 RSCI to MDI conversion.....	17
5.5 Sub-sampling of RSCI.....	18
5.5.1 Frame-level sub-sampling.....	18
5.5.2 Per-TAG-item subsampling .....	18
6 TAG items .....	18
6.1 Format of TAG items .....	19
6.2 Conventions for TAG names.....	19
6.3 General rules for the TAG layer.....	20
6.4 TAG items for RX_STAT.....	20
6.4.1 TAG items for protocol specification .....	20
6.4.1.1 Protocol type and revision (*ptr).....	21
6.4.1.2 DRM logical frame count (dlfc).....	21
6.4.1.3 Type of RX_STAT profile (rpro).....	21
6.4.1.4 Fractional Modified Julian Date (fmjd).....	22
6.4.1.5 Time and date in ASCII notation (time).....	23
6.4.1.6 GPS information (rgps) .....	23
6.4.1.7 Allowed commands (ralc).....	26
6.4.2 TAG items specifying the transmission .....	26
6.4.2.1 Receiver demodulation type (rdmo).....	26
6.4.2.2 Reception frequency (rfre) .....	27
6.4.2.3 Received signal strength (rdbv).....	27
6.4.2.4 Receiver signal to noise ratio (rsnr) .....	28
6.4.3 TAG items specifying receiver settings .....	28
6.4.3.1 Receiver type (rinf) .....	28
6.4.3.2 Receiver activated (ract) .....	29
6.4.3.3 Status of receiver (rsta) .....	29
6.4.3.4 IF filter bandwidth (rbw_).....	30
6.4.3.5 Selected service (rser) .....	31
6.4.3.6 Received test type (rtty) .....	31
6.4.3.7 Audio status (rafs).....	31

6.4.3.8	Extended Audio Status (reas) .....	32
6.4.4	TAG items specifying DRM multiplex .....	33
6.4.4.1	Robustness mode (robm) .....	34
6.4.4.2	Fast Access Channel (fac_) .....	34
6.4.4.3	Service Description Channel (sdc_) .....	35
6.4.4.4	Service Description Channel information (sdc_i) .....	35
6.4.4.5	MSC stream data <n> (str0, str1, str2 and str3) .....	36
6.4.4.6	Gain reference pilots (rpil) .....	37
6.4.5	TAG items for results of measurements .....	38
6.4.5.1	Weighted Modulation Error Ratio for FAC cells (rwmf) .....	38
6.4.5.2	Weighted Modulation Error Ratio for MSC cells (rwmm) .....	39
6.4.5.3	Modulation Error Ratio for actual frame (rmer) .....	40
6.4.5.4	Bit error rate of MSC stream <n> (rbp0, rbp1, rbp2 and rbp3) .....	40
6.4.5.5	Delay window (rdel) .....	41
6.4.5.6	Doppler estimation (rdop) .....	42
6.4.5.7	Power Spectral Density (rpsd) .....	43
6.4.5.8	Narrow Band Interferer (rnic) constellation based .....	44
6.4.5.9	Narrow Band Interferer (rnip) power spectral density based .....	46
6.4.5.10	Power Impulse Response (rpir) .....	48
6.4.6	TAG items for analogue reception .....	48
6.4.6.1	Encoded analogue-mode audio (rama) .....	48
6.4.7	TAG items specifying longer-term statistics .....	49
6.4.7.1	Statistics derived from other TAG items .....	49
6.4.7.1.1	General format of derived statistics TAG items .....	49
6.4.7.1.2	TAG items based on dB values (xdbv, xwmf, xwmm, xmer) .....	50
6.4.7.1.3	Delay statistics (xdel) .....	50
6.4.7.1.4	Doppler statistics (xdop) .....	50
6.4.7.1.5	Power Spectral Density and Power Impulse Response statistics (xpsd, xpir) .....	50
6.4.7.1.6	Narrowband interference statistics (xnip, xnic) .....	50
6.4.7.2	Statistics not derived from other TAG items .....	50
6.4.7.2.1	Receiver status statistics (rsst) .....	50
6.4.7.2.2	Audio quality statistics (rast) .....	51
6.5	TAG items for RX_CTRL .....	51
6.5.1	TAG items for receiver settings .....	52
6.5.1.1	Activate receiver (cact) .....	52
6.5.1.2	Set reception frequency (cfre) .....	52
6.5.1.3	Set receiver demodulation type (cdmo) .....	53
6.5.1.4	Set IF filter bandwidth (cbws and cbwg) .....	53
6.5.1.5	Select service (cser) .....	54
6.5.2	TAG items for signal recording .....	54
6.5.2.1	Start/stop recording (crec) .....	54
6.5.3	TAG items for RSCI output control .....	55
6.5.3.1	Selection of RX_STAT profile (cpro) .....	55
6.6	Revision history .....	56
7	Test and measurement .....	56
	History .....	59

---

## Intellectual Property Rights

IPRs essential or potentially essential to the present document may have been declared to ETSI. The information pertaining to these essential IPRs, if any, is publicly available for **ETSI members and non-members**, and can be found in ETSI SR 000 314: "*Intellectual Property Rights (IPRs); Essential, or potentially Essential, IPRs notified to ETSI in respect of ETSI standards*", which is available from the ETSI Secretariat. Latest updates are available on the ETSI Web server (<http://webapp.etsi.org/IPR/home.asp>).

Pursuant to the ETSI IPR Policy, no investigation, including IPR searches, has been carried out by ETSI. No guarantee can be given as to the existence of other IPRs not referenced in ETSI SR 000 314 (or the updates on the ETSI Web server) which are, or may be, or may become, essential to the present document.

---

## Foreword

This Technical Specification (TS) has been produced by Joint Technical Committee (JTC) Broadcast of the European Broadcasting Union (EBU), Comité Européen de Normalisation ELECTrotechnique (CENELEC) and the European Telecommunications Standards Institute (ETSI).

NOTE: The EBU/ETSI JTC Broadcast was established in 1990 to co-ordinate the drafting of standards in the specific field of broadcasting and related fields. Since 1995 the JTC Broadcast became a tripartite body by including in the Memorandum of Understanding also CENELEC, which is responsible for the standardization of radio and television receivers. The EBU is a professional association of broadcasting organizations whose work includes the co-ordination of its members' activities in the technical, legal, programme-making and programme-exchange domains. The EBU has active members in about 60 countries in the European broadcasting area; its headquarters is in Geneva.

European Broadcasting Union  
CH-1218 GRAND SACONNEX (Geneva)  
Switzerland  
Tel: +41 22 717 21 11  
Fax: +41 22 717 24 81

---

## Introduction

In order to meet the need for a digital transmission system suitable for use in all of the bands below 30 MHz, the Digital Radio Mondiale (DRM) consortium was formed in early 1998. The DRM consortium is a non-profit making body that seeks to develop and promote the use of the DRM system worldwide. Its members include broadcasters, network providers, receiver and transmitter manufacturers and research institutes. More information is available from their website (<http://www.drm.org/>).

A large number of communication protocols have been developed to allow reliable exchange of data using a wide variety of different techniques. Some have relied on two-way communication to allow requests for re-tries of missing or corrupted messages, while others have relied on Forward Error Correcting (FEC) codes such as Reed Solomon to rebuild the original message. Unfortunately most of the protocols are tightly coupled to the application they were originally developed for, do not scale well in multicast networks or are unsuitable for use over the uni-directional circuits often found in distribution systems. When the development of a distribution protocol for Digital Radio Mondiale broadcasts was considered, none of the available protocols was deemed suitable and so it was decided to develop a general purpose, low-level, reliable communications protocol suitable for both uni-directional and bi-directional data links which would meet the needs of DRM but would also hopefully be flexible enough to meet the needs of other applications as well.

The Distribution and Communication Protocol (DCP) describes a common way to transport information over a variety of basic transport protocols like IP, serial line or file. It provides transport information, addressing information, fragmentation to handle limited basic transport protocols and forward error correction to deal with packet losses or packet corruption. The DCP protocol is application-independent and free to use for every organization and purpose. It is specified in TS 102 821 [2]. The actual content to be transported in DRM-specific protocols based on DCP (tailored to individual purposes) is defined in additional documents like the present one.

---

# 1 Scope

The present document defines the actual content to be transported in the DRM-specific protocol **Receiver Status and Control Interface (RSCI)** based on the generic and application-independent **Distribution and Communications Protocol (DCP)** [2]. The RSCI protocol covers the transport of receiver's status information (output protocol) in addition to the DRM multiplex as well as commands (control protocol) to control the receiver's behaviour. The available TAG items for the RSCI TAG layer within the DCP protocol are defined in the present document.

---

## 2 References

References are either specific (identified by date of publication and/or edition number or version number) or non-specific. For specific references, only the cited version applies. For non-specific references, the latest version of the reference document (including any amendments) applies.

Referenced documents which are not found to be publicly available in the expected location might be found at <http://docbox.etsi.org/Reference>.

NOTE: While any hyperlinks included in this clause were valid at the time of publication ETSI cannot guarantee their long term validity.

### 2.1 Normative references

The following referenced documents are necessary for the application of the present document.

- [1] ETSI ES 201 980: "Digital Radio Mondiale (DRM); System Specification".
- [2] ETSI TS 102 821: "Digital Radio Mondiale (DRM); Distribution and Communications Protocol (DCP)".
- [3] ETSI TS 102 820: "Digital Radio Mondiale (DRM); Multiplex Distribution Interface (MDI)".
- [4] ETSI TS 101 968: "Digital Radio Mondiale (DRM); Data applications directory".
- [5] ETSI TS 102 358: "Digital Radio Mondiale (DRM); Specific Restrictions for the use of the Distribution and Communication Protocol (DCP)".
- [6] ITU-R Recommendation P.1407: "Multipath propagation and parameterization of its characteristics".

### 2.2 Informative references

The following referenced documents are not necessary for the application of the present document but they assist the user with regard to a particular subject area.

- [i.1] ETSI TR 101 290: "Digital Video Broadcasting (DVB); Measurement guidelines for DVB systems".

---

## 3 Definitions, symbols, abbreviations and convention

### 3.1 Definitions

For the purposes of the present document, the following terms and definitions apply:

**Alternative Frequency Switching (AFS):** feature of the DRM multiplex, which allows receivers to automatically re-tune to a frequency offering more reliable reception without a break in the decoded audio

**Application Framing (AF):** layer of the DCP providing a logical grouping of a number of TAG items

**byte:** collection of 8 bits

**cell:** sine wave portion of duration  $T_s$ , transmitted with a given amplitude and phase and corresponding to a carrier position

NOTE: Each OFDM symbol is the sum of  $K$  such sine wave portions equally spaced in frequency.

**Coordinated Universal Time (literally Universel Temps Coordonné) (UTC):** time format counting in standard SI seconds with periodic adjustments made by the addition (or removal) of leap seconds to keep the difference between UTC and Astronomical Time less than  $\pm 0,9$  s

NOTE: TAI and UTC were defined as having an initial offset of 10 seconds on January 1<sup>st</sup> 1972 (TAI prior to this date had a variable fractional offset to UTC as the two times did not use the same definition of the second). As at February 25<sup>th</sup> 2003 there have been 22 leap seconds, all positive, making  $TAI = UTC + 32$ .

**Distribution and Communication Protocol (DCP):** transport layer communications protocol providing fragmentation, addressing and/or reliable data transmission over error inserting channels using a Reed Solomon (RS) code to provide Forward Error Correction (FEC) as defined in TS 102 821 [2]

**Fast Access Channel (FAC):** channel of the multiplex data stream, which contains the information that is necessary to find services and begin to decode the multiplex

**Global Position System (GPS):** constellation of satellites providing accurate time and position information to receivers

**GPS time:** time signal broadcast by the GPS satellites using an epoch of January 6<sup>th</sup> 1980 with no leap seconds and a "week number" (actually a modulo-604 800 seconds number) that wraps every 1 024 weeks (approximately 19,7 years)

**Greenwich Mean Time (GMT):** historically the standard time for all international applications, now superseded by UTC

**International Atomic Time (literally Temps Atomique International) (TAI):** time format counting in standard SI seconds

NOTE: TAI and GPS Time have a constant offset of 19 seconds.

**logical frame:** contains MSC data of one stream during 400 ms (robustness modes A to D) or 100 ms (robustness mode E)

**Main Service Channel (MSC):** channel of the multiplex data stream which occupies the major part of the transmission frame and which carries all the digital audio services, together with possible supporting and additional data services

**MDI packet:** TAG packet containing those TAG items as defined in TS 102 820 [3]

**mod:** modulo operator

NOTE:  $(x \text{ mod } y) = z$ , where  $y > 0$ , such that  $x = qy + z$ ,  $q$  is an integer, and  $0 \leq z < y$ .

**Modified Julian Date (MJD):** date format based on the number of days since midnight GMT on 17<sup>th</sup> November 1858 AD

NOTE: Time can be represented as a fraction of a day, however as MJD is subject to leap seconds, the fractional part corresponding to an SI second is of variable size and hence complex to implement in a fixed width bit-field.

**Multiplex Distribution Interface (MDI):** protocol specification for the link between a DRM multiplexer and a DRM modulator carrying the description of a complete DRM multiplex in a way that reliable networks of transmitters can be constructed as defined in TS 102 820 [3]

**multiplex frame:** logical frames from all streams form a multiplex frame

NOTE: It is the relevant basis for coding and interleaving.

**OFDM symbol:** transmitted signal for that portion of time when the modulating amplitude and phase state is held constant on each of the equally-spaced carriers in the signal

**Quality of Service in AM (QoSAM):** European project to develop and validate real time tools for measurement and monitoring of service quality to insure the best achievable quality according to the propagation channel

**Recommended Standard 232:** interface between data terminal equipment and data communications equipment employing serial binary data interchange

**reserved for future addition (rfa):** bits with this designation are set to zero and receivers will ignore these bits

**reserved for future use (rfu):** bits with this designation are set to zero and receivers will check that these bits are zero in order to determine the valid status of the other fields in the same scope

**Service Description Channel (SDC):** channel of the multiplex data stream, which gives information to decode the services included in the multiplex

NOTE: The SDC also provides additional information to enable a receiver to find alternative sources of the same data.

**short Id:** short identifier assigned to a service and used as a reference in the SDC

NOTE: The short Id is assigned for the duration of the service and is maintained through multiplex reconfigurations.

**SI second:** SI base unit of time is the duration of 9 192 631 770 periods of the radiation corresponding to the transition between the two hyperfine levels of the ground state of the cesium 133 atom

**stream Id:** identifier of an MSC stream

NOTE: The short Id is the identifier of a *service*, which is linked by SDC application information data entity - type 5 (see ES 201 980 [1], clause 6.4.3.6) or SDC audio information data entity - type 9 (see ES 201 980 [1], clause 6.4.3.10) to an MSC *stream* identified by a stream Id.

**TAG header:** TAG item consists of header and value; the TAG header holds name and length of the TAG item

**TAG item:** DCP elemental type combining in a single logical data the name, length and value of the data

**TAG length:** length of the payload of a TAG item in bits

**TAG name:** name field within an individual TAG item used to identify an individual piece of information

**TAG packet:** collection of TAG items with a header carrying a cohesive and self-contained block of data

**TAG value:** payload of a TAG item

**transmission frame:** number of consecutive OFDM symbols (duration of 400 ms for robustness modes A to D or 100 ms for robustness mode E), whereby the first OFDM symbol contains the time reference/frame synchronization cells

**transmission super frame:** three consecutive transmission frames for robustness modes A to D (duration of 1 200 ms) or four consecutive transmission frames for robustness mode E (duration of 400 ms), whereby the first transmission frame contains the SDC block

**World Geodetic System 1984 (WGS84):** geodetic reference system used by GPS

NOTE 1: The origin of the WGS84 framework is the earth's centre of mass.

NOTE 2: GPS receivers compute and store coordinates in terms of WGS84, then if required transform to other datums when information is displayed.

## 3.2 Symbols

For the purposes of the present document, the following symbols apply:

$K$	number of active carriers in the OFDM symbol
$K_{\max}$	carrier index of the upper active carrier in the OFDM signal
$K_{\min}$	carrier index of the lower active carrier in the OFDM signal



$N_x$  The value  $N$  is expressed in radix  $x$

NOTE: The radix of  $x$  is decimal, thus  $2A_{16}$  is the hexadecimal representation of the decimal number 42.

$T_f$  duration of a transmission frame

$T_s$  duration of an OFDM symbol

$\lceil x \rceil$  the smallest integral value numerically greater than  $x$

NOTE: Sometimes known as the "ceiling" function or round towards plus infinity.

$\lfloor x \rfloor$  the largest integral value numerically less than  $x$

NOTE: Sometimes known as the "floor" function or round towards minus infinity.

### 3.3 Abbreviations

For the purposes of the present document, the following abbreviations apply:

AAC Advanced Audio Coding

AF Application Framing

NOTE: A DCP protocol layer.

AFS Alternative Frequency Switching

AM Amplitude Modulation

ASCII American Standard Code for Information Interchange

BER Bit Error Rate

CELP Code Excited Linear Prediction

CRC Cyclic Redundancy Check

DCP Distribution and Communication Protocol

DMDI DRM Multiplex Distribution Interface

DRM Digital Radio Mondiale

ESC Error Sensitivity Category

FAC Fast Access Channel

NOTE: A DRM multiplex component.

FEC Forward Error Correction

FF File Framing

NOTE: A DCP Protocol Layer.

FFT Fast Fourier Transformation

GMT Greenwich Mean Time

GPS Global Positioning System

GUI Graphical User Interface

HF High Frequency

HVXC Harmonic Vector eXcitation Coding

IF Intermediate Frequency

IP Internet Protocol

IQ Inphase and Quadrature component

LSb Least Significant bit

LSB Least Significant Byte

MDI Multiplex Distribution Interface

MER Modulation Error Ratio

MJD Modified Julian Date

MSb Most Significant bit

MSB Most Significant Byte

MSC Main Service Channel

NOTE: A DRM multiplex component.

OFDM Orthogonal Frequency Division Multiplex

PFT Protection, Fragmentation and Transport

NOTE: A DCP protocol layer.

PRBS Pseudo Random Bit Sequence  
 PSD Power Spectral Density  
 QAM Quadrature Amplitude Modulation  
 QoSAM Quality of Service in AM  
 RF Radio Frequency  
 rfa reserved for future addition  
 rfu reserved for future use  
 RMS Root Mean Square

NOTE: = Square root of the mean squared value.

RS Reed Solomon  
 RS232 Recommended Standard 232  
 RSCI Receiver Status and Control Interface  
 RX\_CTRL Receiver ConTRoL information  
 RX\_STAT Receiver STATus information  
 SBR Spectral Band Replication  
 SDC Service Description Channel

NOTE: A DRM multiplex component.

SI International System of units  
 TAI International Atomic Time

NOTE: Literally Temps Atomique International.

TCP Transmission Control Protocol

NOTE: IP based protocol.

UDP User Datagram Protocol

NOTE: IP based protocol.

UTC Coordinated Universal Time

NOTE: Literally Universel Temps Coordonné.

WGS84 World Geodetic System 1984  
 WMER Weighted Modulation Error Ratio

## 3.4 Convention

All numbers are decimal, thus the radix is 10, unless otherwise stated by  $N_x$  (see clause 3.2).

The order of bits and bytes within each description shall use the following notation unless otherwise stated:

- In figures, the bit or byte shown in the left hand position is considered to be first.
- In tables, the bit or byte shown in the left hand position is considered to be first.
- In byte fields, the Most Significant bit (MSb) is considered to be first and denoted by the higher number. For example, the MSb of a single byte is denoted "b7" and the Least Significant bit (LSb) is denoted "b0".
- In vectors (mathematical expressions), the bit with the lowest index is considered to be first.

## 4 System conception for DRM coverage monitoring

Current professional or monitoring DRM receivers are based on different architectures (see figure 4.1). To enable test equipment to be used for all of those receivers, the definition of a standardized interfacing protocol is necessary. To overcome the difficulties that the receiver implementations are based on different platforms a TCP/UDP/IP based approach is chosen.

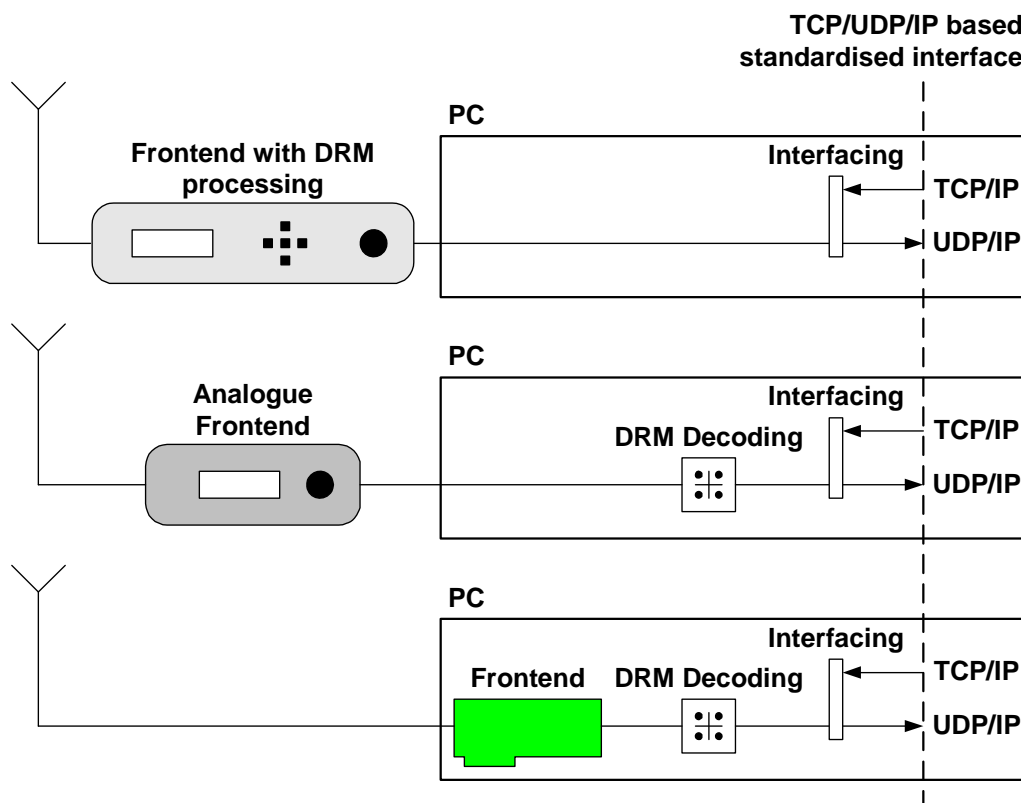

**Figure 4.1: Different architectures of DRM monitoring receivers**

The standardized interface features a uni- or bi-directional link for control and a uni-directional link for status information. Receiver Control information (RX\_CTRL), like setting of the reception frequency or recording commands, are fed to a PC connected to the DRM decoder/receiver by the streaming orientated UDP/IP protocol or (more reliable) the connection orientated TCP/IP protocol. Receiver Status information (RX\_STAT), like the received field strength, signal to noise ratios, audio status, bit error rates or even the received bit stream, are provided each DRM multiplex frame by the connected PC via the streaming orientated UDP/IP protocol. To ensure correct transmission and to encapsulate transmitted data, further protocol layers are added for control and status of the transmission.

The basic principle of the set-up for a monitoring system is depicted in figure 4.2. All the distributed and automatically running remote DRM receivers are respectively connected to a computer dedicated to data collection. The DRM receiver and the data collector can certainly be one unit. The data collector evaluates the RSCI protocol stream coming from the DRM receiver, extracts the needed data and prepares this data for network transfer to the data analyser. The time slots to be monitored are signalled by the scheduler, which can be located at the same place as the data analyser or elsewhere. The central data analysis site collects the data uploaded by the different receivers in order to perform further analysis.

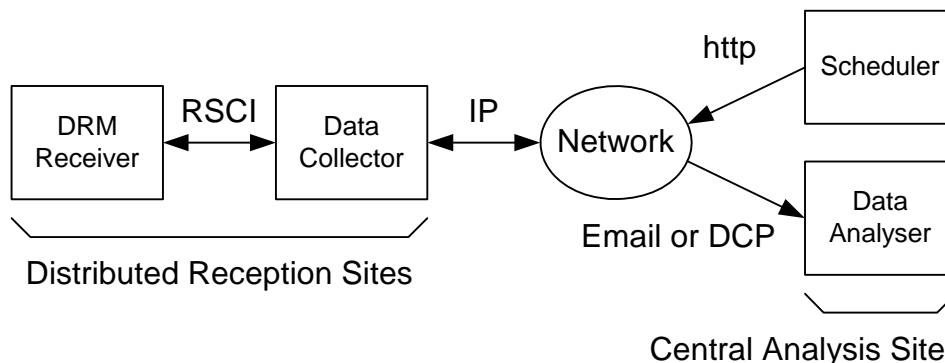

**Figure 4.2: Basic monitoring set-up**

The receiver is one part of such a system and if different receiver types provide standardized output and control functions, this simplifies the set-up.

## 5 Protocols, profiles and rules

### 5.1 Protocols

In order to enable easy exchange of different types of receivers in a test set-up two interfaces are defined for receiver status and control. A RSCI-compliant receiver shall provide one of those two interfaces:

- DCP TAG/AF layer via UDP/IP or TCP/IP for RX\_CTRL and DCP TAG/AF layer via UDP/IP for RX\_STAT. TCP/IP and UDP/IP shall be available either direct on a PC-based receiver or accessible by a PC.
- DCP TAG/AF layer via RS232 for RX\_CTRL and RX\_STAT.

If a receiver has no TCP/IP and/or UDP/IP interface and no RS232 interface, the receiver may be extended by some kind of module (e.g. a PC), which provides the required interfaces.

**NOTE:** When using the streaming orientated UDP/IP protocol for RX\_CTRL, the user has to be aware of the problem which comes with every uni-directional protocol - the possibility that command packets could get lost without notice, especially if there is no possibility of monitoring the effects of sent commands.

The DCP TAG/AF layer is described in detail in TS 102 821 [2].

### 5.2 Profiles

To ensure interoperability between different control, receiver and status units a mandatory subset of TAG items is required. As different scenarios may require different subsets, profiles are defined.

Each profile defines:

- TAG items, which shall be transmitted (RX\_STAT) by a receiver unit; and
- TAG items, which shall be evaluated (RX\_CTRL) by a receiver unit.

Those TAG items are called mandatory for this profile.

Profiles for RX\_STAT and RX\_CTRL information may be mixed, so that a receiver may be capable of profile A for RX\_STAT and profile B for RX\_CTRL.

## 5.2.1 Standard Profiles

There are seven standard profiles for different requirements and bit rates:

- Profile A: normal profile (FAC, SDC, MSC, no pilots, all measurement values).
- Profile B: very low bit rate profile (no FAC, no SDC, no MSC, no pilots, most measurement values).
- Profile C: low bit rate profile (FAC, SDC, no MSC, no pilots, most measurement values).
- Profile D: high bit rate profile (FAC, SDC, MSC, pilots, all measurement values).
- Profile G: profile intended for frame-level subsampling (FAC, SDC, no MSC, no pilots, PSD, PIR and statistics tags).
- Profile Q: QoSAM profile (TAG items needed for the QoSAM project).
- Profile R: minimum receiver profile (FAC, SDC, MSC, no pilots, no measurement values).

Tables 5.1 and 5.3 are to give an overview of all the TAG items out of the RSCI protocol, the byte size to be transmitted for each of these TAG items (TAG header plus TAG value) and their appearance in the different RX\_STAT or RX\_CTRL profiles. The size of the TAG header is always 8 bytes as specified in clause 6. Therefore the size of the useful TAG value is eight bytes smaller than the given TAG item size in the second column of these tables - this reduced value should now correspond with the TAG length given in the descriptions of the TAG items (see clauses 6.4.1 to 6.4.5). TAG items which may have a TAG length of zero in dependence of the level of synchronization of the receiver (see clause 6.4 and the according descriptions of the TAG items) or other receiver settings are marked with \*) in the TAG item size column of table 5.1.

Table 5.2 provides an informative basis on the data rates to be expected for the individual RX\_STAT profiles. For these data rate values it is not taken into account that some TAG items may sometimes have a TAG length of zero (see clause 6.4), but only the TAG item sizes given in table 5.1.

Table 5.1: Overview of RX\_STAT TAG items in profiles

Name of TAG item	Size of TAG item (bytes)	Profile A	Profile B	Profile C	Profile D	Profile G	Profile Q	Profile R
*ptr	16	✓	✓	✓	✓	✓	✓	✓
dlfc	12	✓	✓	✓	✓	✓	✓	✓
rpro	9	✓	✓	✓	✓	✓	✓	✓
fmjd	16	✓	✓	✓	✓	✓	✓	
time	33	R			R			
rgps	34 *	✓			✓	✓		
rdmo	12	✓	✓	✓	✓	✓	✓	
rfre	12 *	✓	✓	✓	✓	✓	✓	
rdbv	10 to 56 *	✓	✓	✓	✓		✓	
rsnr	10 *	R	R	R	R			
rinf	24	✓	✓	✓	✓	✓	✓	
ract	9	✓	✓	✓	✓	✓	✓	
rsta	12 *	✓	✓	✓	✓		✓	
rbw_	10 *	✓	✓	✓	✓	✓		
rser	9 *	✓	✓	✓	✓	✓	✓	
rtty	12 *	✓	✓	✓	✓	✓	✓	
rafs	14 *	✓	✓	✓	✓		✓	
reas	13 to 48 *	✓		✓	✓			
robm	9 *	✓	✓	✓	✓	✓	✓	✓
fac_	17 or 23 *	✓		✓	✓	✓	✓	✓
sd_	24 to 218 *	✓		✓	✓	✓		✓
sdci	12 to 21 *	✓		✓	✓	✓	✓	✓
str0	32 to 3 630 *	✓			✓			✓
str1		✓			✓			✓
str2		✓			✓			✓
str3		✓			✓			✓
rpil	384 to 5 836 *				✓			
rwmf	10 *	✓	✓	✓	✓		✓	
rwm	10 *	✓	✓	✓	✓		✓	
rmer	10 *	✓	✓	✓	✓		✓	✓
rbp0	12 *	✓	✓	✓	✓			
rbp1	12 *	✓	✓	✓	✓			
rbp2	12 *	✓	✓	✓	✓			
rbp3	12 *	✓	✓	✓	✓			
rdel	11 to 38 *	✓	✓	✓	✓		✓	
rdop	10 *	✓	✓	✓	✓		✓	
rnic	15 *	✓	✓	✓	✓			
rnip	13 *	✓	✓	✓	✓			
rpsd	93 to 147 *	✓			✓			
rama	variable							
ralc	min. 9	R	R	R	R	R		
rpil	6 to 260					✓		
xdbv	variable					✓		
xwmf						✓		
xwmm						✓		
xmer						✓		
xdel						✓		
xdop						✓		
xpsd						✓		
xpir						✓		
rsst		8					✓	
rast	2					✓		

\* TAG items may have a TAG length of zero in dependence of the level of synchronization of the receiver or other receiver settings.

✓ = TAG item is mandatory for this profile.

[empty] = TAG item is optional for this profile.

R = TAG item is optional but recommended for this profile.

Table 5.2: Data rates of RX\_STAT profiles

Data rate of profile	Profile A	Profile B	Profile C	Profile D	Profile G	Profile Q	Profile R
Minimal data rate [bytes/frame]	538	313	379	922	variable	256	141
Minimal data rate [bytes/s]	1 345	782,5	947,5	2 305	variable	640	352,5
Maximal data rate [bytes/frame]	4 504	386	660	10 340	variable	338	3 942
Maximal data rate [bytes/s]	11 260	965	1 650	25 850	variable	845	9 855

Table 5.3: Overview of RX\_CTRL TAG items in profiles

Name of TAG item	Size of TAG item	Profile A	Profile B	Profile C	Profile D	Profile G	Profile Q	Profile R
cact	9 bytes	✓	✓	✓	✓	✓	✓	✓
cfre	12 bytes	✓	✓	✓	✓	✓	✓	✓
cdmo	12 bytes	✓	✓	✓	✓	✓	✓	✓
cbws	10 bytes							
cbwg	10 bytes							
cser	9 bytes	✓	✓	✓	✓	✓	✓	✓
crec	12 bytes							
cpro	9 bytes	✓	✓	✓	✓	✓	✓	✓

✓ = TAG item is mandatory for this profile.  
[empty] = TAG item is optional for this profile.

## 5.2.2 User-defined profiles

In addition to the standard profiles defined in clause 5.2.1, additional profiles may be defined by the user, either in terms of existing profiles in combination with overall sub-sampling (see clause 5.5.1), or by specifying a subset of TAG items. Such profiles shall be identified by the numbers "1" to "9" and these values may be used in the "cpro" and "rpro" TAG items (see clauses 6.4.1.3 and 6.5.3.1).

A standard way of defining a user profile may be specified in a future version of the present document.

## 5.3 Timing

The timing of the FAC (and SDC) data related to the corresponding MSC data differs on the receiver side depending on the interleaving that is used for the MSC data in the DRM multiplex. For robustness modes A to D, short interleaving is confined within one transmission frame, while long interleaving spans five transmission frames. For robustness mode E, fixed interleaving spans six transmission frames.

### 5.3.1 Short interleaving (robustness modes A to D)

The following figure 5.1 shows what parts of the data streams are transmitted in the same DRM transmission frame if short interleaving is used: These are the FAC (and SDC) data together with the related MSC data, which is the complete data of this DRM multiplex frame.

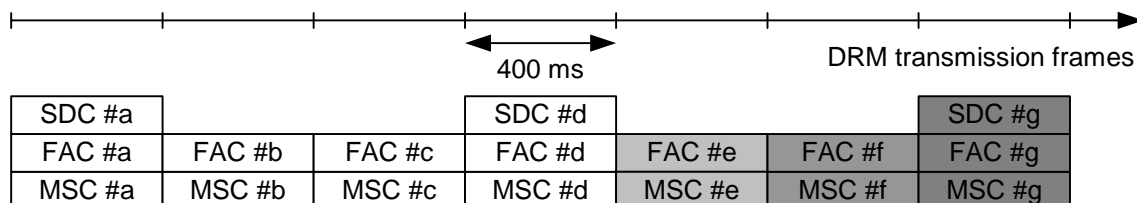

Figure 5.1: DRM signal on air and also output of de-interleaver (short interleaving)

On the receiver side at the output of the de-interleaver the decoding of the FAC (and SDC) data and the completion of the related MSC data occurs therefore in the same DRM transmission frame. The content of the RSCI stream looks exactly the same as the output of the de-interleaver: figure 5.2 shows the used TAG items (see clauses 6.4.4.2, 6.4.4.3 and 6.4.4.5) and the togetherness of the transported data.

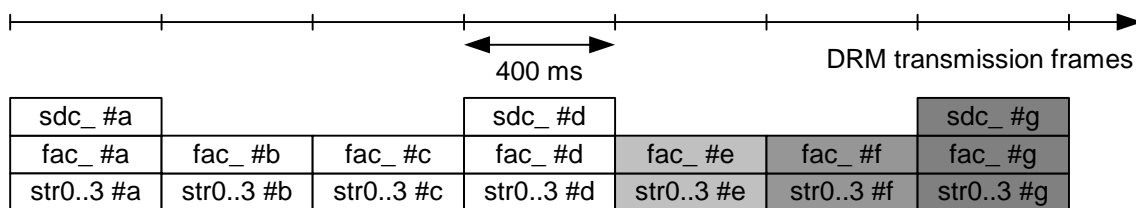

Figure 5.2: Content of RSCI stream (short interleaving)

### 5.3.2 Long interleaving (robustness modes A to D)

The following figure 5.3 shows what parts of the data streams are transmitted in the same DRM transmission frame if long interleaving is used: These are the FAC (and SDC) data together with the first fifth of the related MSC data plus four fifths of MSC data out of previous DRM logical frames, because long interleaving spreads the MSC data of one DRM logical frame over five frames while the related FAC (and SDC) data are fully carried in the first DRM transmission frame.

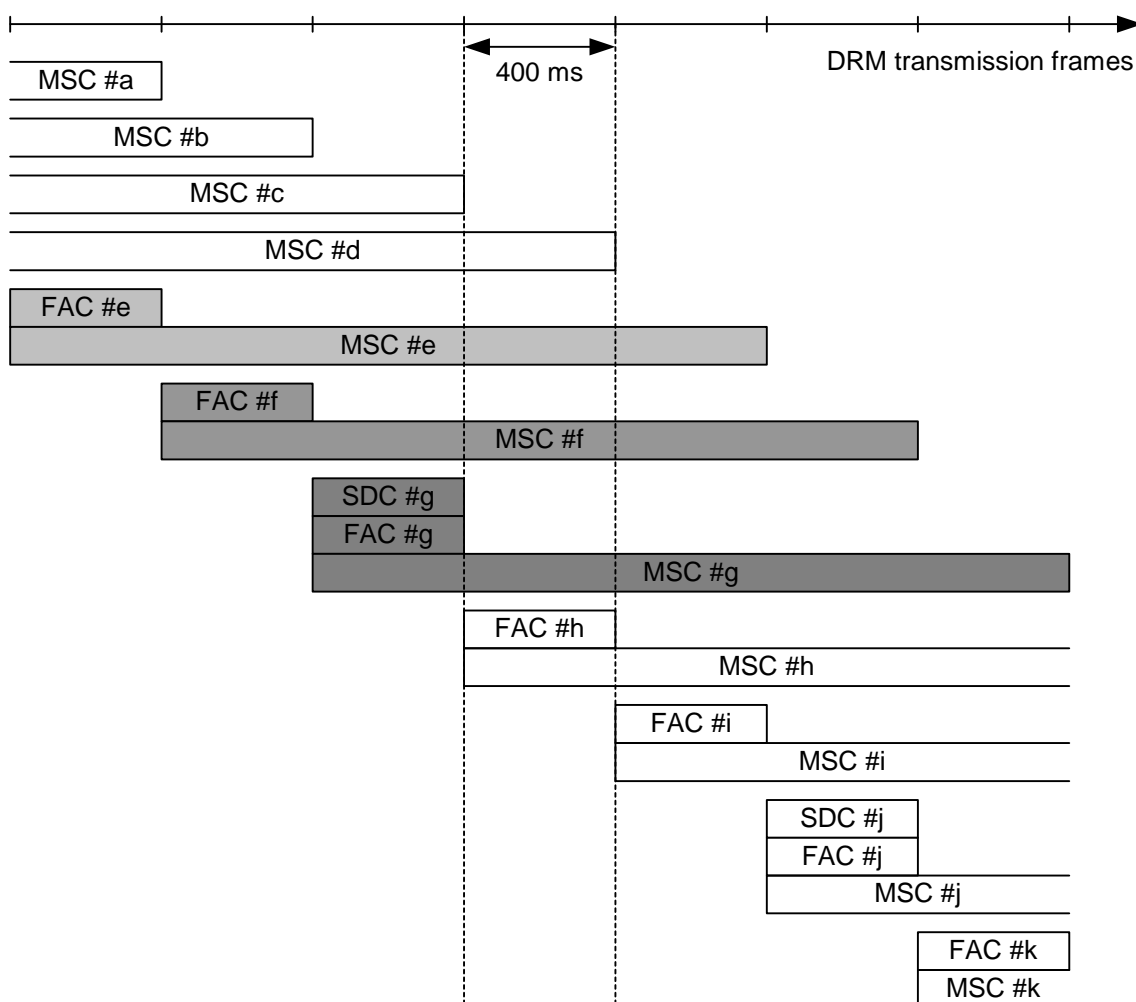
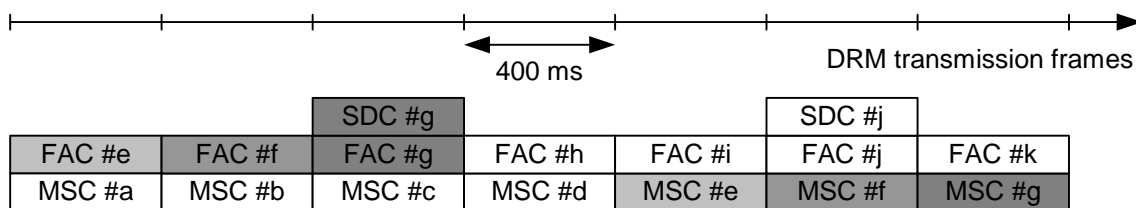

Figure 5.3: DRM signal on air (long interleaving)

On the receiver side at the output of the de-interleaver a delay of four DRM transmission frames shows up between the decoding of the FAC (and SDC) data and the completion of the related MSC data. This fact can be seen from figure 5.3 and is illustrated in figure 5.4.





**Figure 5.4: Output of de-interleaver (long interleaving)**

The content of the RSCI stream looks exactly the same as the output of the de-interleaver: figure 5.5 shows the used TAG items (see clauses 6.4.4.2, 6.4.4.3 and 6.4.4.5) and the togetherness of the transported data.

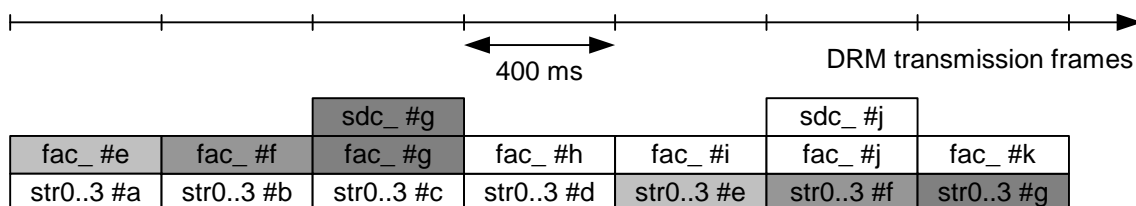

**Figure 5.5: Content of RSCI stream (long interleaving)**

### 5.3.3 Fixed interleaving (robustness mode E)

The mechanism described in clause 5.3.2 applies for the fixed interleaver, although there are six rather than five transmission frames involved.

The FAC (and SDC) data together with the first sixth of the related MSC data plus five sixths of MSC data out of previous DRM logical frames are present, because fixed interleaving spreads the MSC data of one DRM logical frame over six frames while the related FAC (and SDC) data are fully carried in the first DRM transmission frame.

On the receiver side at the output of the de-interleaver a delay of five DRM transmission frames shows up between the decoding of the FAC (and SDC) data and the completion of the related MSC data.

The content of the RSCI stream looks exactly the same as the output of the de-interleaver.

## 5.4 RSCI to MDI conversion

As stated in TS 102 820 [3] one MDI packet shall comprise FAC, SDC and MSC data with a correlation in time. This correlation gets lost at the de-interleaver output of the receiver if long interleaving or fixed interleaving is used for the MSC data in the DRM multiplex (see clauses 5.3.2 and 5.3.3 respectively).

This implies directly that a RSCI stream (of profile A, D or R) shall not be used without changes as input stream of a device expecting a MDI stream. Before doing so the togetherness of the transported FAC (and SDC) data with the MSC data has to be rebuilt correctly, as shown in figure 5.6 for long interleaving. This may be done by a delay of four transmission frames for the FAC (and SDC) data in the case that long interleaving was used for the MSC data or a delay of five transmission frames in the case of fixed interleaving. Additionally the TAG item "\*ptr" shall be adjusted to signal the new type of stream using the content "DMDI" together with the matching protocol revision number as stated in TS 102 820 [3], clauses 5.1.1 and 5.3.

NOTE 1: The TAG items of RSCI RX\_STAT are completely compatible with the ones used for MDI, only the timing differs in the case of long interleaving or fixed interleaving.

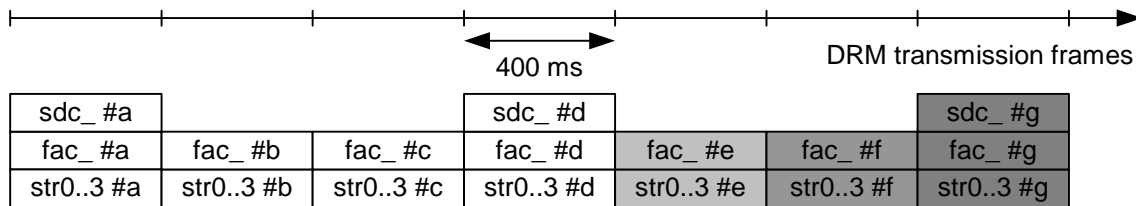

**Figure 5.6: Expected content for MDI stream for long interleaving**

NOTE 2: If short interleaving was used the necessary correlation in time is automatically given at the de-interleaver output because the MSC data of one frame was not spread over several DRM transmission frames.

## 5.5 Sub-sampling of RSCI

The full RSCI profiles may have too high a bit-rate for use over low bit-rate or high cost links. Two forms of sub-sampling may be used in order to reduce the bit-rate to acceptable levels: frame-level sub-sampling and per TAG-item sub-sampling.

Neither sub-sampling mechanism shall be used with profiles "A"- "D", "Q" or "R". Sub-sampling according to either mechanism may be used with any other standard profile and may also be used with user-defined profiles.

### 5.5.1 Frame-level sub-sampling

Conceptually, an RSCI TAG packet shall be generated every DRM transmission frame. However, not every RSCI packet need be actually transmitted, and instead a receiver may send only packet in every  $N$  frames. In this case, the dlfc count (see clause 6.4.1.2) shall be incremented for every transmission frame, so that the transmitted values shall jump by the subsampling ratio. This may be used by a decoder to determine how many frames have been omitted.

For the TAG packets which are not transmitted, no lower layer (i.e. AF or PFT) packet shall be generated and therefore the sequence numbers in the transmitted AF and PFT layers shall increment as normal without skipping any values.

NOTE: Sub-sampling of RSCI may usefully be combined with the use of statistics tags as described in clause 6.4.7.

### 5.5.2 Per-TAG-item subsampling

Sub-sampling may also be performed on a per-TAG item basis. This can result in a reduction in data rate whilst still providing some information for every transmission frame.

NOTE: When combined with DCP compression (see TS 102 821 [2]) this can significantly reduce the data rate. Disabling the AF CRC (see TS 102 821 [2]) will help to improve the compression performance.

## 6 TAG items

For ease of reference, the basic structure of a TAG packet and the TAG items it contains is described in figure 6.1.

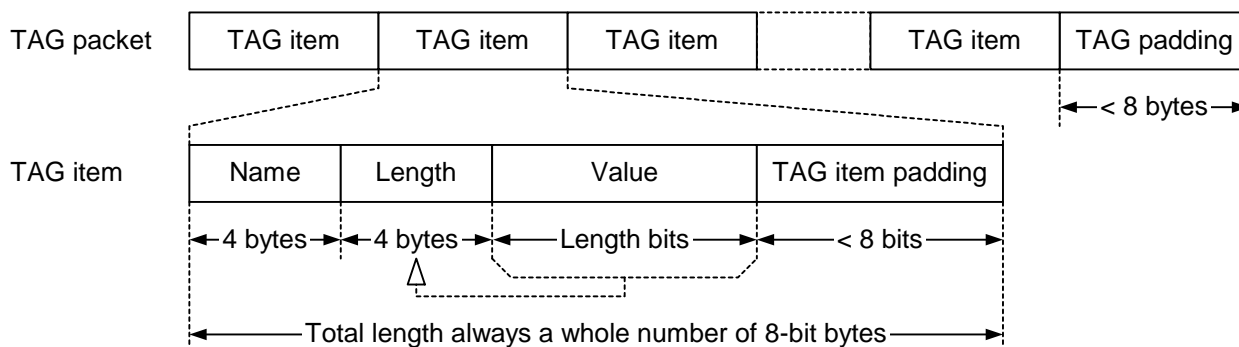

**Figure 6.1: TAG packet and TAG item overview**

The definition of the TAG layer is contained in detail in TS 102 821 [2], clause 5. The present document only contains a copy of the description out of TS 102 821 [2]. In the case of differences the description in TS 102 821 [2] is valid. All conventions and restrictions given in clauses 6.1 to 6.3 apply in addition to what is stated in TS 102 821 [2], clause 5.

## 6.1 Format of TAG items

The TAG layer is part of the Application Framing (AF) layer and forms the interface between the application and the DCP protocol. For the exact definition of the TAG layer see TS 102 821 [2].

The TAG layer is used to multiplex multiple data streams into one data stream (it combines multiple TAG items to one TAG packet). Output of the TAG layer is TAG packets. Each TAG packet consists of a seamless list of TAG items. Each TAG item has the following structure:

- The TAG header contains a fixed portion of 8 bytes length, which includes the following information:
  - **TAG name:** a four-byte name in ASCII characters used to identify the data value carried in the TAG item.
  - **TAG length:** a four-byte value representing the number of bits in the TAG value field.
- The TAG value section contains the data for the respective TAG item, which shall always comprise a number of full bytes ( $n \times 8$  bits) and shall be in format of Most Significant bit (MSb) first in each byte. All numeric data shall be in network byte order (= big endian):
  - **TAG value:** any value as required by the application.

NOTE: If the TAG length is not a multiple of 8 then the remaining bits of the last byte is padded with zero bits. The number of transmitted bytes is  $((\text{TAG length} + 7) \bmod 8)$ .

- **TAG item padding:** up to seven zero bits to make the total length of the TAG item a whole number of bytes.

## 6.2 Conventions for TAG names

All TAG names defined for RX\_STAT and RX\_CTRL TAG items are lower case (all four characters).

Except for additional proprietary TAG items each company may add - these TAG names shall start with a capital letter while the remaining three characters are again lower case. The naming conventions for these proprietary TAG items are defined in detail in TS 102 358 [5], clause 5.2. For ease of reference table 6.1 gives a shortened overview of the available TAG name first letters for additional proprietary RSCI TAG items extracted from TS 102 358 [5], clause 5.2, table 2. In the case of differences the description in TS 102 358 [5] is valid.

**Table 6.1: Naming of proprietary TAG items**

<b>TAG name first letter (ASCII, upper case)</b>	<b>To be used for proprietary TAG items by</b>
A to T	Already in use by individual DRM members or reserved for future assignment to individual DRM members.
U, V, W, X, Y, Z	Freely available to be used by any DRM member.
0 to 9	Freely available to be used by any person or organization.

TAG names starting with the asterisk character "\*" belong to (application protocol independent) Control TAG items (see TS 102 821 [2], clause 5.2.2).

## 6.3 General rules for the TAG layer

All TAG items may have any order within the TAG Packet.

Unknown TAG items shall be ignored by a parser unit.

## 6.4 TAG items for RX\_STAT

The TAG items in clause 6.4 are defined for RX\_STAT communication.

Every 400 ms, in the case of robustness modes A to D, or 100 ms, in the case of robustness mode E, all TAG items are transmitted as one TAG packet even if the receiver is not synchronized to a DRM signal or the demodulation type is not "DRM". If the receiver gets synchronization the receiver may send a new TAG packet sooner. The packets are sent regardless if there is a device listening or not (or indeed whether the receiver is tuned to a DRM signal or not).

All mandatory TAG items of the RX\_STAT profile currently used shall be present in each TAG packet. All other TAG items - optional or recommended - may be present.

**NOTE:** A receiver which is titled to be compliant to a specific RX\_STAT profile is therefore be able to generate and calculate at least all TAG items marked as mandatory for this RX\_STAT profile. Or the other way round: A receiver capable of generating and calculating at least all mandatory TAG items of a specific RX\_STAT profile may be titled compliant to this RX\_STAT profile.

If the TAG value of a TAG item has a fixed size then the size is given at the point TAG length. Some of the TAG items have variable data length due to a variable size of the TAG value. This is indicated by the expression "variable". The length is then given in the TAG value description. For some TAG items the TAG value may sometimes not be available. Such TAG items are marked by "or 0" at the point TAG length.

**EXAMPLE:** If there is no FAC available because of demodulation type is "AM" or due to no synchronization in demodulation type "DRM" then the TAG length of TAG item "fac\_" is zero.

The receiver shall fill in TAG items whenever the receiver has the TAG value available. The receiver is not allowed to leave out some of the TAG items which are mandatory for the chosen RX\_STAT profile because of user selections or because the TAG value is not available.

The communication is uni-directional.

The data originates at the receiver.

### 6.4.1 TAG items for protocol specification

For ease of reference the definition for TAG item "\*ptr" with protocol name "RSCI" is copied from TS 102 821 [2], clause 5.2. In the case of differences the description in TS 102 821 [2] is valid.

For ease of reference the definition for TAG items "dlfc" and "\*ptr" with protocol name "DMDI" are copied from TS 102 820 [3], clause 5.1. In the case of differences the description in TS 102 820 [3] is valid.

### 6.4.1.1 Protocol type and revision (\*ptr)

It is highly recommended that every application using the DCP protocol should declare a protocol type and revision in every TAG packet using the "\*ptr" TAG item as shown in figure 6.2. This TAG item requires no TAG item padding and is mandatory for all RX\_STAT profiles.

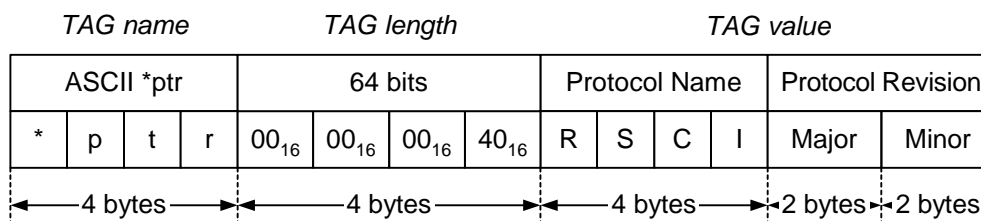

**Figure 6.2: Protocol type and revision RSCI**

**Protocol name:** The ASCII string "RSCI" (Receiver Status and Control Interface) as the name of the protocol. Typically this will be encoded using ASCII values in the range 20<sub>16</sub> to 7F<sub>16</sub>, but values outside this range may be used if desired.

**Protocol revision, major:** A binary counter representing the major version number of the protocol, starting from 00<sub>16</sub>. The currently used value is 04<sub>16</sub>.

**Protocol revision, minor:** A binary counter representing the minor version number of the protocol, starting from 00<sub>16</sub>. The currently used value is 00<sub>16</sub>.

For further information on the revision numbering refer to clause 6.6.

### 6.4.1.2 DRM logical frame count (dlfc)

This TAG item, as shown in figure 6.3, shall be included in every RSCI TAG packet and is therefore mandatory for all RX\_STAT profiles.

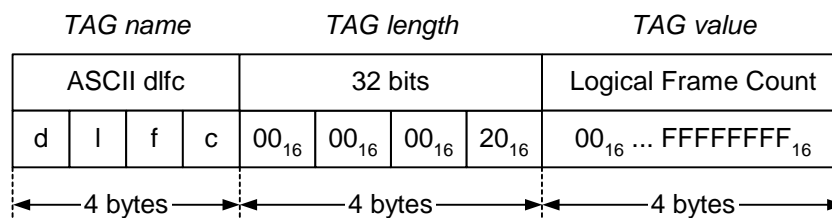

**Figure 6.3: DRM logical frame count**

**Logical frame count:** 32-bit unsigned integer value as a data packet counter.

The value of the counter shall be incremented by one for each TAG packet sent by the device generating the TAG packets. In the event that the maximum value is reached, the counter shall reset to zero: FFFFFFFE<sub>16</sub>, FFFFFFFF<sub>16</sub>, 00000000<sub>16</sub>, 00000001<sub>16</sub>, etc. The receiver shall not expect or require the first packet to have a specific value of the logical frame count. This counter shall be used by the receiving unit of the TAG packets to ensure that packets which arrive out-of-order are re-ordered correctly. The logical frame count may also be used to detect lost TAG packets and, if a suitable link exists, request re-transmission of the lost packets.

NOTE: Due the length of 32 bits this counter covers a time span of about 54 (13,5) years if one packet containing this TAG item is sent every 400 ms (100 ms).

### 6.4.1.3 Type of RX\_STAT profile (rpro)

For analysis of the received RX\_STAT profile and to know at the listening unit what information is provided within the actual protocol stream the name of the used profile shall be included using the "rpro" TAG item as shown in figure 6.4. Therefore this TAG item is also mandatory for all RX\_STAT profiles.

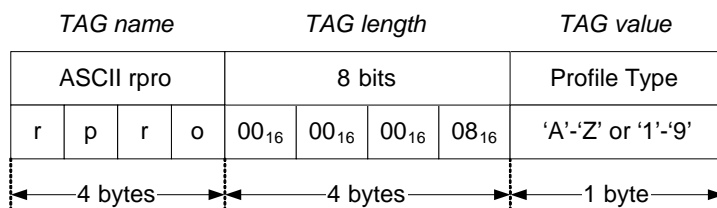
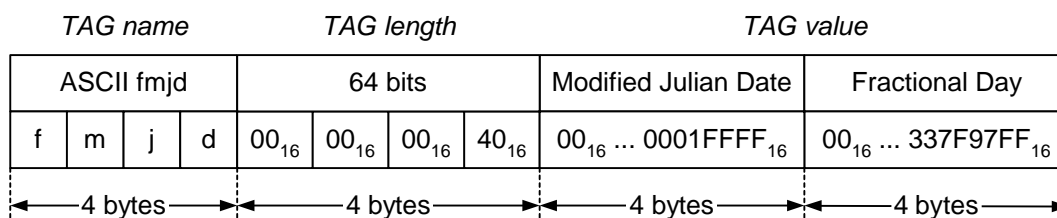

**Figure 6.4: Type of RX\_STAT profile**

**Profile type:** ASCII character "A", "B", "C", etc. as name of the actual RX\_STAT profile, or ASCII character "1" to "9" to indicate a user-defined profile.

#### 6.4.1.4 Fractional Modified Julian Date (fmjd)

This TAG item holds the fractional Modified Julian Date (MJD) of the reception as shown in figure 6.5. The time describes as closely as possible the arrival of the first signals of the first symbol of the actual transmission frame at the Radio Frequency (RF) input of the receiver. If a receiver has no real time clock the time signalled in this TAG item should start at the time the receiver is powered on. This TAG item is mandatory for all RX\_STAT profiles except profile R.



**Figure 6.5: Fractional Modified Julian Date**

**Modified Julian Date:** 32-bit integer value (only 17 bits are used) for the MJD of the actual day.

A conversion algorithm could look like this:

```

/* move leap day virtual to end of year */
modified_month = ((month + 9) mod 12) + 3; /* month is 1..12 */
modified_year = year - 1 + [(month + 7) / 10];

/* intermediate variables */
n1 = [modified_year / 100];
n2 = modified_year mod 100;

JulianDate = 1721029 /* offset January, 1st 4713 BCE */
+ 146097 * [n1 / 4] /* days of elapsed 400-year-cycles */
+ 36524 * (n1 mod 4) /* days of elapsed 100-year-cycles */
+ 1461 * [n2 / 4] /* days of elapsed 4-year-cycles */
+ 365 * (n2 mod 4) /* days of elapsed years */
+ 30 * modified_month /* days of elapsed months in actual year */
+ [(7 * (modified_month - 2)) / 12] /* days of unequal month-length */
+ day; /* elapsed days in actual month */

/* modification from JD to MJD is -2400000.5 */
/* 08.10.2001 00:00:00 = 2452190.5 JD = 52190.0 MJD (to integer) = 52190 MJD */
/* 08.10.2001 12:00:00 = 2452191.0 JD = 52190.5 MJD (round down) = 52190 MJD */
/* 08.10.2001 23:59:59 = 2452191.49999 JD = 52190.99999 MJD (round down) = 52190 MJD */
ModifiedJulianDate = JulianDate - 2400001;

```

NOTE 1: Today's (March 1<sup>st</sup> 2004) MJD is 53 065. With 17 bits we can go up to day 131 071, which corresponds to another 213 years.

**Fractional Day:** the fractional day is the number of 1/10 ms that passed since midnight that day, using UTC time.

NOTE 2: There are  $86\,400 \times 10\,000$  tenths of a millisecond a day which is approximately  $2^{30}$ , so 32 bits are sufficient.

### 6.4.1.5 Time and date in ASCII notation (time)

This TAG item has got the same function as the TAG item "fmjd" above, but is in ASCII notation as shown in figure 6.6 for readability when looking at the RSCI data stream with a simple text editor. Because this TAG item does not give any information beyond the "fmjd" TAG item, it is only optional for the both high data rate RX\_STAT profiles A and D.

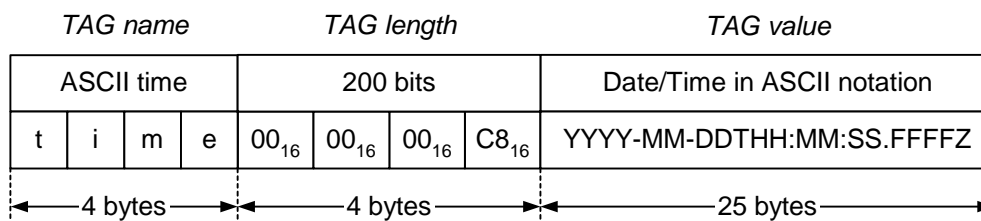

**Figure 6.6: Time and date in ASCII notation**

Date and time information is provided in ASCII notation "YYYY-MM-DDTHH:MM:SS.FFFFZ" with:

YYYY	year
MM	month (January = "01" ... December = "12")
DD	day (starting with "01" at first day of each month)
T	the letter "T" as separator
HH	hour
MM	minutes
SS	seconds
FFFF	fractional seconds with a resolution of 0,1 ms
Z	the letter "Z" for Zero Median (i.e. UTC)

EXAMPLE: 2004-03-01T12:34:56.7890Z stands for March 1<sup>st</sup> 2004, 34 minutes and 56,7890 seconds past 12 UTC.

### 6.4.1.6 GPS information (rgps)

This TAG item gives information on the position and movement of the receiver using the GPS satellite positioning system as shown in figure 6.7. If no GPS information is available an empty TAG item shall be transmitted. This TAG item is mandatory for RX\_STAT profiles A and D.

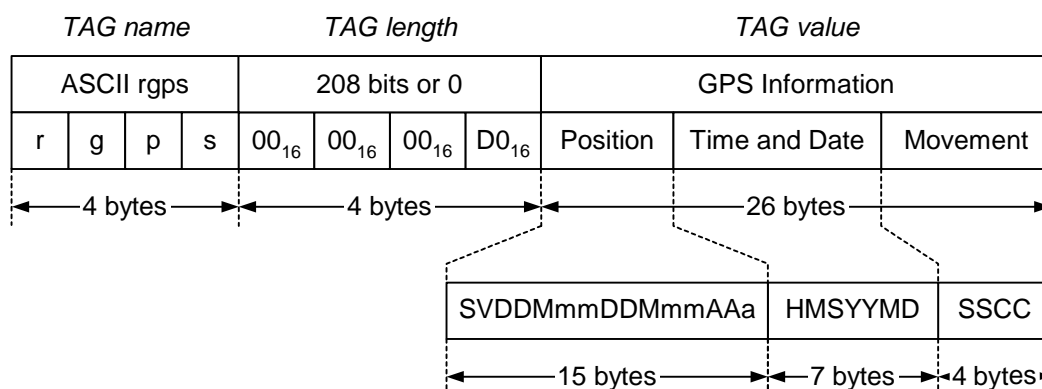

**Figure 6.7: GPS information**

The positioning information shall be acquired using the WGS84 grid, to allow the use of other positioning systems beside GPS. This information is written to the TAG value in the following format "SVDDMmmDDMmmAAA" with:

S	source of the position data as 8-bit unsigned integer value with the meanings listed below
	0 <sub>16</sub> invalid
	1 <sub>16</sub> GPS receiver
	2 <sub>16</sub> differential GPS receiver
	3 <sub>16</sub> manual entry
	FF <sub>16</sub> not available
V	number of satellites in view as 8-bit unsigned integer value
	FF <sub>16</sub> not available
Latitude	latitude value as $(DD + (M + mm / 65\ 536) / 60)$ in degrees with positive values mean north and negative values mean south
	FFFF_FF_FFFF <sub>16</sub> if not available
DD	latitude degrees as 16-bit signed integer value
M	latitude minutes as 8-bit unsigned integer value
mm	latitude fractional minutes in steps of 1/65 536 as 16-bit unsigned integer value

NOTE 1: In detail the calculation process for the latitude value stored in the TAG item is as follows. The position information is given by a NMEA stream out of a GPS unit. The NMEA data for the latitude value (for example taken from the dataset "RMC" = recommended minimum sentence) is an ASCII string consisting of two or more characters for the degrees (X), two for the minutes (Y) value, the dot character, three or more characters for the fractional minutes (y) value: "XXXYY.yyy" A subsequent character "N" or "S" distinguishes between north and south.

For northern latitude values the calculation is straight forward:  $DD = XXX$ ,  $M = YY$  and  $mm = \text{integer part of } (0,yyy \cdot 65\ 536)$ . For southern latitude values the calculation is a little bit more complicated in order to satisfy the decoding rule of  $(DD + (M + mm / 65\ 536) / 60)$ :  $DD = -XXX - 1$ ,  $ZZ,zzz = 60 - YY,yyy$ ,  $M = ZZ$  and  $mm = \text{integer part of } (0,zzz \times 65\ 536)$ . The used variable characters "X" to "Z" (in upper as well as lower case) stand in for single digits or more of them for strings of digits. They have to be converted to numbers before calculation or assignment to the TAG item values.

For the illustration of the procedure described in this note please read the following examples from right to left.

EXAMPLE 1:  $DDMmm = 002F\_04\_3F92_{16}$  means latitude =  $+47^\circ + 4,24832' = 47^\circ 4,24832'$  North

EXAMPLE 2:  $DDMmm = FFD1\_04\_3F92_{16}$  means latitude =  $-47^\circ + 4,24832' = 46^\circ 55,75168'$  South

EXAMPLE 3:  $DDMmm = FFD0\_37\_C06E_{16}$  means latitude =  $-48^\circ + 55,75168' = 47^\circ 4,24832'$  South

NOTE 2: If you want to create a floating point value for the latitude calculate  $(DD + (M + mm / 65\ 536) / 60)$ . The result gives the latitude in degrees with positive values mean north and negative values mean south.

Longitude	longitude value as $(DD + (M + mm / 65\ 536) / 60)$ in degrees with positive values mean east and negative values mean west
	FFFF_FF_FFFF <sub>16</sub> if not available
DD	longitude degrees as 16-bit signed integer value
M	longitude minutes as 8-bit unsigned integer value
mm	longitude fractional minutes in steps of 1/65 536 as 16-bit unsigned integer value

NOTE 3: The calculation process for the longitude value is the same as for the latitude value with "north" and "south" replaced by "east" respectively "west".

EXAMPLE 4:  $DDMmm = 00AA\_04\_3F92_{16}$  means longitude =  $+170^\circ + 4,24832' = 170^\circ 4,24832'$  East

EXAMPLE 5:  $DDMmm = FF56\_04\_3F92_{16}$  means longitude =  $-170^\circ + 4,24832' = 169^\circ 55,75168'$  West

EXAMPLE 6:  $DDMmm = FF55\_37\_C06E_{16}$  means longitude =  $-171^\circ + 55,75168' = 170^\circ 4,24832'$  West



NOTE 4: If you want to create a floating point value for the longitude calculate  $(DD + (M + mm / 65\ 536) / 60)$ . The result gives the longitude in degrees with positive values mean east and negative values mean west.

NOTE 5: The achievable resolution of the latitude value is  $1 / 65\ 536' = 2,8$  cm as  $1' = 1$  nautical mile. For the longitude value this is only the case at the equator. Going to the north or the south one longitude fractional minutes step equals a decreasing distance of  $(1 / 65\ 536' \cdot \cos(\text{latitude value}))$ .

NOTE 6: The position calculation rules for this TAG item were changed (corrected) from RSCI protocol revision 3.1 to 3.2. There was an error in the definition which lead to the fact that some positions (near the zero meridian and near the equator) could not be mapped whereas other position information were ambiguous.

Altitude altitude value as  $(AA + a / 256)$  in meters above sea level  
 FFFF\_FF<sub>16</sub> if not available  
 AA altitude meters as 16-bit signed integer value  
 a altitude fractional meters in steps of 1/256 as 8-bit unsigned integer value

EXAMPLE 7: AAa = 0123\_DF<sub>16</sub> means altitude =  $291 + 0,871 = 291,871$  meters above sea level

EXAMPLE 8: AAa = FFFE\_DF<sub>16</sub> means altitude =  $-2 + 0,871 = 1,129$  meters below sea level

EXAMPLE 9: AAa = FFFE\_21<sub>16</sub> means altitude =  $-2 + 0,129 = 1,871$  meters below sea level

NOTE 7: If you want to create a floating point value for altitude calculate  $(AA + a / 256)$ .

NOTE 8: This is the same as to put "AA" and "a" into a signed 24-bit integer value ("AA" is the higher part) or into the lower three bytes of a signed 32-bit integer value ("AA" is the higher part, setting the MSB to 00<sub>16</sub> or FF<sub>16</sub> whether "AA" is positive or negative) and to divide this value by 256.

GPS date and time information is provided in the following format "HMSYYMD" with:

Time: hours (24h format), minutes and seconds in UTC time  
 FF\_FF\_FF<sub>16</sub> if not available  
 H hours as 8-bit unsigned integer value  
 M minutes as 8-bit unsigned integer value  
 S seconds as 8-bit unsigned integer value  
 Date: year, month and day in UTC time  
 FFFF\_FF\_FF<sub>16</sub> if not available  
 YY year as 16-bit as unsigned integer value  
 M number of month as 8-bit unsigned integer value (January = 1<sub>10</sub> ... December = 12<sub>10</sub>)  
 D number of day as 8-bit unsigned integer value (starting with 1<sub>10</sub> at first day of each month)

Movement information is provided in the following format "SSCC" with:

Speed: speed over ground as  $(SS / 10)$  in [m/s]; a stationary receiver should set speed to 0  
 FFFF<sub>16</sub> if not available  
 SS speed data as 16-bit unsigned integer value  
 Heading: heading degrees clockwise from north [0; 360]; a stationary receiver should set heading to 0  
 FFFF<sub>16</sub> if not available  
 CC heading data as 16-bit unsigned integer value

### 6.4.1.7 Allowed commands (ralc)

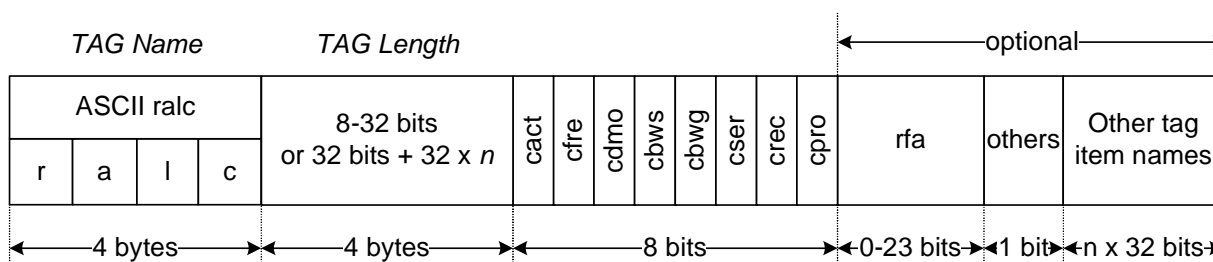

Figure 6.7a

Each 1-bit field indicates whether the receiver will respond to the corresponding command. "1" indicates that the receiver will respond, "0" indicates that the command will be ignored.

The minimum TAG length shall be 8 bits.

Three options are available for the TAG length:

- 8 bits: The bits indicate the commands already defined above.
- 16, 24 or 32 bits: The additional "rfa" bits beyond the original 8 are reserved for future commands to be defined in future versions of the present document. If the length of the TAG item is shorter than the number of defined bits, this shall be equivalent to transmitting a "0" for the bits that are not transmitted.
- More than 32 bits: The "rfa" bits are as above. If the "others" bit is "1", the additional "other tag item names" bits carry TAG names for additional commands that are supported. This allows proprietary commands to be signalled.

Optionally, the TAG may be extended to indicate other commands. In this case the "optional" part of the TAG is transmitted and the TAG length signalled accordingly.

**rfa:** These bits may be defined in future versions of the present document to correspond to new commands. The commands shall be allocated to the bits in the same order as they appear in table 5.3.

**others:** If this field is set to "1", the subsequent field shall carry TAG names each indicating a further command that is supported.

**Other TAG item names:** This field contains *n* concatenated 32 bit fields, each containing a 4-byte TAG name of a supported command in the same format as the "TAG Name" field of the TAG item header.

## 6.4.2 TAG items specifying the transmission

The following TAG items are to specify the demodulation type of the current received transmission and at which frequency and signal strength this transmission is received.

### 6.4.2.1 Receiver demodulation type (rdmo)

This TAG item holds the receiver's actual demodulation type in ASCII notation as shown in figure 6.8 and is mandatory for all RX\_STAT profiles except profile R.

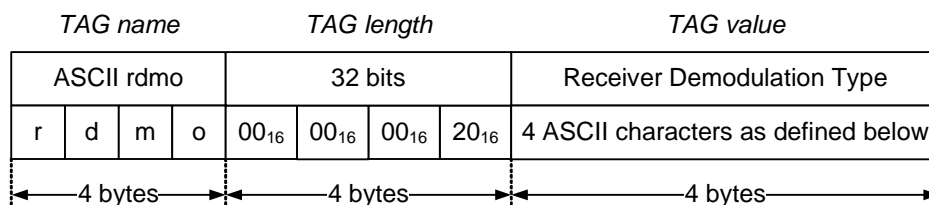

Figure 6.8: Receiver demodulation type

The information of the actual demodulation type of the receiver is given as four ASCII characters:

drm_	DRM demodulation (robustness modes A to D)
drm+	DRM demodulation (robustness mode E)
am_	AM demodulation
usb_	Upper Side Band demodulation
lsb_	Lower Side Band demodulation
sam_	Synchronous AM demodulation
nbfm	Narrowband FM demodulation (i.e. communications-band FM)
wbfm	Wideband FM demodulation (i.e. broadcast-band FM)

### 6.4.2.2 Reception frequency (rfre)

If this information is available for the unit generating the RSCI protocol stream, the reception frequency of the current transmission should be signalled using the "rfre" TAG item as shown in figure 6.9. In case that the frequency information is not available to the unit generating the RSCI protocol stream, an empty TAG item shall be inserted. This TAG item is mandatory for all RX\_STAT profiles except profile R.

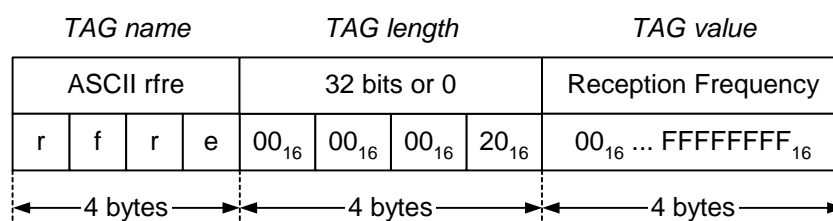

Figure 6.9: Reception frequency

**Reception frequency:** 32-bit unsigned integer value in [Hz].

### 6.4.2.3 Received signal strength (rdbv)

The following TAG item is used to include the Root Mean Square (RMS) of the received signal strength within the bandwidth occupied by the DRM signal into the protocol stream as shown in figure 6.10. Several signal strength values may be included in this TAG item, which is mandatory for all RX\_STAT profiles except profile R. If no signal strength information is available an empty TAG item shall be transmitted.

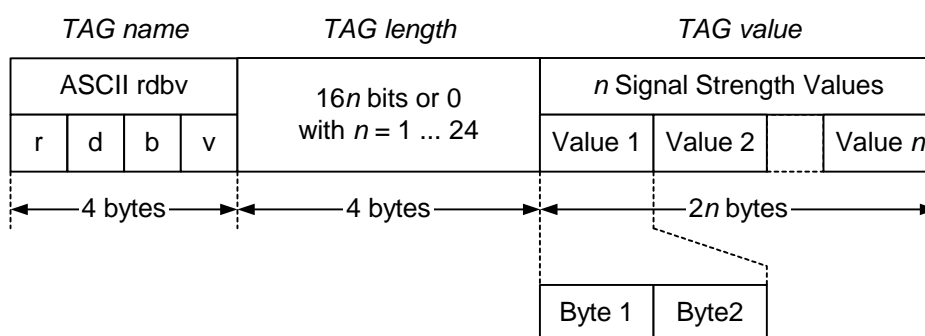

Figure 6.10: Received signal strength

**Signal strength value:** the format of a single value is  $(\text{Byte1} + \text{Byte2} / 256) = (\text{Byte1}.\text{Byte2})$  in [dBμV] with:

- Byte1 is an 8-bit signed integer value; and
- Byte2 is an 8-bit unsigned integer value.

NOTE 1: This is the same as to put Byte1 and Byte2 into a signed 16-bit integer value (Byte1 is the higher part) and to divide this value by 256.

The measurement time of each signal strength value is the length of a DRM transmission frame divided by the number of values in the TAG item, which can be calculated by (length of DRM transmission frame / ("rdby" TAG length / 16)). The suggested measurement time for one signal strength value is one DRM transmission frame, which results in the minimum number of one value per TAG item. The maximum number of signal strength values is one per OFDM symbol, which results in the maximum number of 40 values per TAG item if transmission mode E is received.

The unit [dB $\mu$ V/m] is used to indicate the field strength (which is independent of the antenna factor) in contrast to [dB $\mu$ V] which is commonly used for the signal strength (which is dependent of the antenna factor). It is easy to estimate the field strength by just adding the antenna factor (usually a few dB) to the signal strength.

NOTE 2: (value in [dB $\mu$ V]) = (value in [dBm]) + 107 dB in case of receiver input impedance of 50  $\Omega$ .

#### 6.4.2.4 Receiver signal to noise ratio (rsnr)

The following TAG item is used to include the received signal to noise ratio (SNR) within the bandwidth occupied by the DRM signal into the protocol stream as shown in figure 6.11. The SNR tag item is recommended for most profiles. If no signal strength information is available an empty TAG item shall be transmitted.

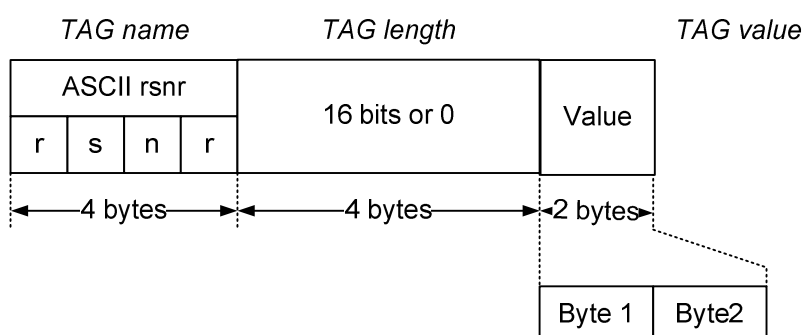

Figure 6.11: Received signal to noise ratio

**Signal to noise ratio:** the format of a single value is  $(\text{Byte1} + \text{Byte2} / 256) = (\text{Byte1}.\text{Byte2})$  in [dB] with:

- Byte1 is an 8-bit signed integer value; and
- Byte2 is an 8-bit unsigned integer value.

NOTE 1: This is the same as to put Byte1 and Byte 2 into a signed 16-bit integer value (Byte1 is the higher part) and to divide this value by 256.

The measurement time of each SNR value is the length of a DRM transmission frame (400 ms for robustness modes A to D and 100 ms for robustness mode E). The exact measurement specification is not given, however, most receivers have an estimate of the SNR value available for various reasons.

NOTE 2: Different receiver implementation may estimate the SNR differently.

### 6.4.3 TAG items specifying receiver settings

The following TAG items are to specify the type and status of the currently used receiving equipment.

#### 6.4.3.1 Receiver type (rinf)

To provide information about the used receiver - manufacturer, type, version and serial number - the following TAG item is used as shown in figure 6.11a. This TAG item is mandatory for all RX\_STAT profiles except profile R.

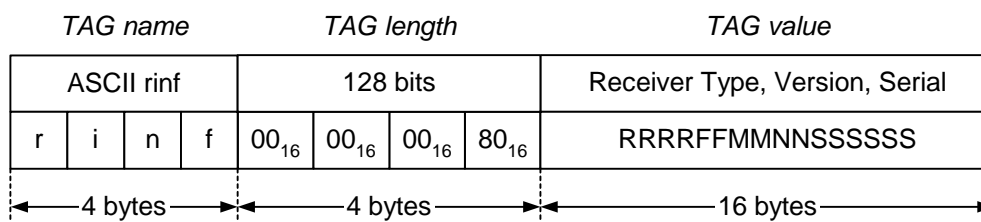

**Figure 6.11a: Receiver type**

Receiver type, version number and serial number are provided in ASCII notation "RRRRFFMMNNSSSSSS" with:

RRRR	is used to identify the receiver manufacturing company. Yet defined are bbc_ by use of BBC British Broadcasting Corporation fhg_ by use of FhG Fraunhofer Gesellschaft rfm_ by use of RFmondial GmbH thal by use of Thales Broadcast & Multimedia
FF	is set to identify different receiver implementations of this company
MM	major revision number in two ASCII characters
NN	minor revision number in two ASCII characters
SSSSSS	serial number of the decoder in six ASCII characters (number characters are from "0" to "9")

#### 6.4.3.2 Receiver activated (ract)

If the receiving equipment is activated or deactivated for reception is signalled by the following TAG item as shown in figure 6.12. This TAG item is mandatory for all RX\_STAT profiles except profile R.

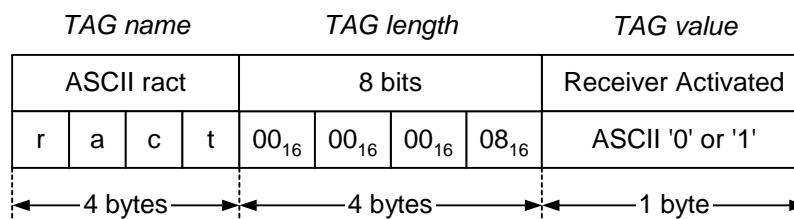

**Figure 6.12: Receiver activated**

**Receiver activated:** this ASCII character gives the active status of the reception equipment as follows:

ASCII "0"	deactivated
ASCII "1"	activated

#### 6.4.3.3 Status of receiver (rsta)

The following TAG item as shown in figure 6.13 gives information on the receiver status in terms of the decoding process. If the demodulation type of the receiver is not "DRM", an empty TAG item shall be transmitted. This TAG item is mandatory for all RX\_STAT profiles except profile R. The audio decoding status byte of the TAG value relates to the actual selected service (see clause 6.4.3.5).

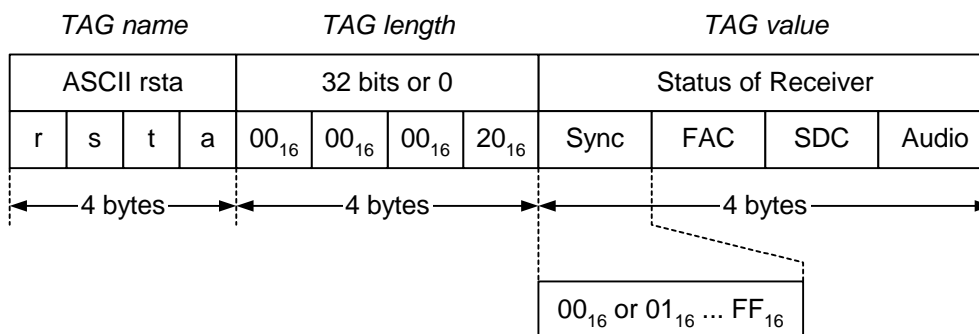

**Figure 6.13: Status of receiver**

**Status of receiver:** Four bytes, treated as 8-bit unsigned integer values, are indicating the status of the four main decoding stages. Positive values are standing for an error at that stage while zero means everything ok.

- Status of synchronization: A positive value shall be set while there is no synchronization to a DRM signal or while the synchronization is in progress but not yet finished.
- Status of FAC decoding: A positive value shall be set if the CRC of the actual FAC block is not correct or if other decoding problems like not allowed values are detected.
- Status of SDC decoding: A positive value shall be set if the CRC of the actual SDC block is not correct or if other decoding problems like not allowed values or corrupted data entities are detected.
- Status of audio decoding: A positive value shall be set if one or more audio frames are corrupted within one DRM multiplex frame or even if no audio frames are available.

**NOTE:** In robustness mode E, the audio super frame duration is 200 ms. Therefore, "audio" information is only available every other RSCI packet. To be consistent, the preceding status of audio decoding should be repeated in the intermittent packet.

#### 6.4.3.4 IF filter bandwidth (rbw\_)

The following TAG item holds the bandwidth of the input IF filter of the receiver as shown in figure 6.14. If no IF filter bandwidth information is available an empty TAG item shall be transmitted. This TAG item is mandatory only for RX\_STAT profiles A, B, C and D.

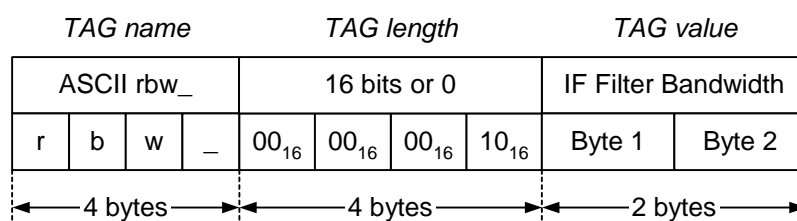

**Figure 6.14: IF filter bandwidth**

**IF filter bandwidth:** the format is  $(\text{Byte1} + \text{Byte2} / 256) = (\text{Byte1}.\text{Byte2})$  in [kHz] with:

- Byte1 is an 8-bit unsigned integer value; and
- Byte2 is an 8-bit unsigned integer value.

**NOTE:** This is the same as to put Byte1 and Byte2 into a signed 16-bit integer value (Byte1 is the higher part) and to divide this value by 256.

### 6.4.3.5 Selected service (rser)

The actual selected service at the GUI is given by the following TAG item as shown in figure 6.15. This information is important in order to know which service the audio status (see clauses 6.4.3.3, 6.4.3.7 and 6.4.3.8) belongs to. Therefore this TAG item is mandatory for all RX\_STAT profiles except profile R. If the receiver is not in synchronization, an empty TAG item shall be transmitted.

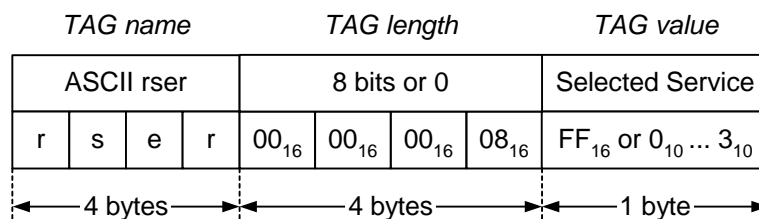

Figure 6.15: Selected service in GUI

**Selected service:** 8-bit signed integer value specifying the short Id (0 to 3) of the selected service or FF<sub>16</sub> if none.

### 6.4.3.6 Received test type (rtty)

To specify the content of the MSC data stream in terms of special content for test & measurement (see clause 7) the following TAG item is used as shown in figure 6.16. This TAG item is mandatory for all RX\_STAT profiles except profile R. If no MSC data is available, an empty TAG item shall be transmitted.

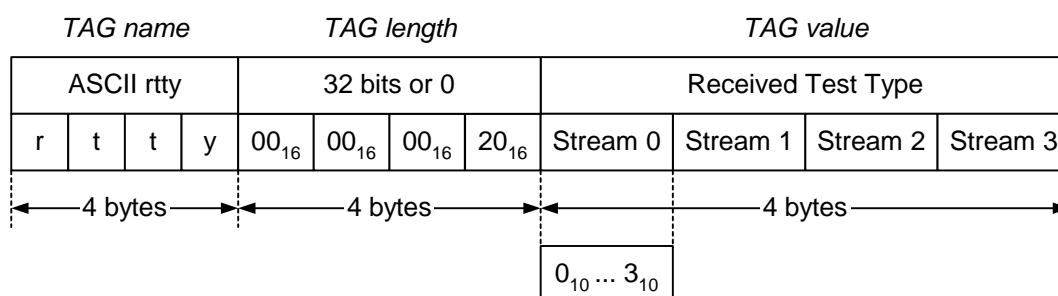

Figure 6.16: Received test type

**Received test type:** four bytes (one for each stream Id) specifying the content of an MSC stream as follows:

- 0<sub>10</sub> stream is not available
- 1<sub>10</sub> stream holds no test content
- 2<sub>10</sub> stream contains synchronous PRBS
- 3<sub>10</sub> stream contains asynchronous PRBS

The first byte of the TAG value holds the received test type for the MSC stream with stream Id 0, ..., the fourth byte holds the received test type for the MSC stream with stream Id 3.

### 6.4.3.7 Audio status (rafs)

This TAG item is used to signal the status of the audio decoder with a time base of one audio unit as shown in figure 6.17. Because of the importance of this information this TAG item is mandatory for all RX\_STAT profiles except profile R. The given TAG value relates to the actual selected service (see clause 6.4.3.5). Whenever no information on audio unit decoding is available (e.g. if no audio service is selected or if no MSC data is available) then the TAG length of the TAG item "rafs" shall be zero.

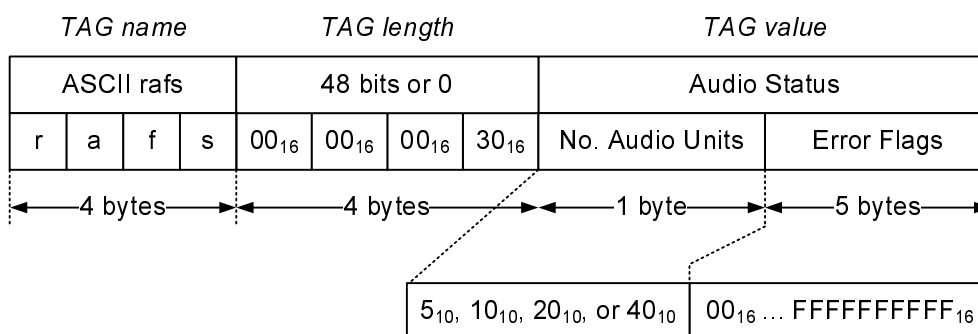

**Figure 6.17: Audio status**

**No. audio units:** number of audio units per audio super frame.

For robustness modes A to D, one audio super frame is of 400 ms duration and consists of:

- 5 audio units in case of MPEG-4 AAC with 12 kHz sampling rate, or
- 10 audio units in case of MPEG-4 AAC with 24 kHz sampling rate, or
- 20 audio units in case of MPEG-4 HVXC, or
- 10, 20 or 40 audio units in case of MPEG-4 CELP.

For robustness mode E, one audio super frame is of 200 ms duration and consists of:

- 5 audio units in case of MPEG-4 AAC with 24 kHz sampling rate, or
- 10 audio units in case of MPEG-4 AAC with 48 kHz sampling rate.

For further details of the audio coding used in the DRM system see ES 201 980 [1], clause 5.

**Error flags:** a 40-bit field carrying the binary-coded audio status with one bit representing the decoding status of one audio unit. The bit field is filled from the left; i.e. the MSb of the first byte describes the decoding status of the first audio unit of the audio super frame. When fewer than 40 audio units are present in the audio super frame, the corresponding unused bits are set to zero. The used values for the error flags have the following meaning:

0 <sub>2</sub>	audio unit is ok
1 <sub>2</sub>	audio unit is corrupted

**NOTE:** In the case of robustness mode E, useful "rafs" data is only available in every alternate RSCI packet, since the audio super frame duration is twice the RSCI packet repetition rate; therefore the TAG length of the TAG item "rafs" is zero for alternate packets (those where the FAC toggle parameter = 1).

#### 6.4.3.8 Extended Audio Status (reas)

In addition to the TAG item "rafs" above (see clause 6.4.3.7) the status of the audio decoder can be described in more detail using the TAG item "reas" as shown in figure 6.18. This TAG item is mandatory for the higher datarate RX\_STAT profiles A, C and D only. The given TAG value relates to the actual selected service (see clause 6.4.3.5). Whenever no audio units are available (e.g. if no audio service is selected or if no MSC data is available) then the TAG length of the TAG item "reas" shall be zero.

This more detailed differentiation of errors within an audio unit is done because errors which are located within the less sensitive part of the audio data can be concealed in many cases by the source decoding process in a way that they are possibly not recognized by a human listener. But errors which are located within the high sensitive data part will be audible in nearly all cases.



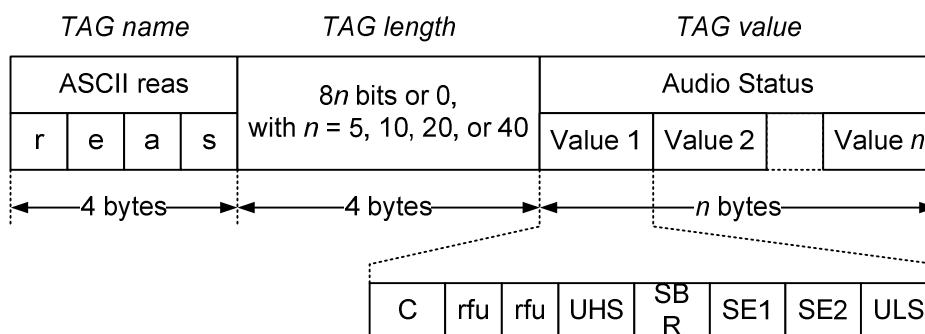

Figure 6.18: Extended audio status

**Audio status values:** 8-bit unsigned integer value specifying the status of one audio unit with eight separate error flags as explained below. A classification of errors may be done in the following way:

00 <sub>16</sub>	audio unit is ok
01 <sub>16</sub> ... 0F <sub>16</sub>	audio unit is corrupted, but the errors are only located within the less sensitive part
10 <sub>16</sub> ... FF <sub>16</sub>	audio unit is corrupted, errors are located within the high sensitive part and maybe also within the less sensitive part

One byte of error status shall be provided by the audio decoder for each audio unit (see clause 6.4.3.7).

**C (core CRC error flag):** for MPEG-4 AAC and CELP coding this is the error status of the CRC check concerning the core data part; for MPEG-4 HVXC coding this is the error status of the CRC check concerning the ESC0 data part of the audio unit.

**rfu:** these two bits are reserved for future use and shall have the value zero.

**UHS (Unspecified High Sensitive error flag):** decoder dependent error flag for all other detected errors within the high sensitive data part of the audio unit.

**SBR (SBR CRC error flag):** error status of the CRC check concerning the SBR data part of the audio unit.

**SE1 (Spectral data Error flag no. one):** for MPEG-4 AAC coding this is the error status of the spectral data part (in case of stereo coding only of the left channel spectral data part); for MPEG-4 CELP coding this flag is not used and shall have the value zero; for MPEG-4 HVXC coding this is the combined error status of the CRC check concerning the ESC1, ESC2 and if present ESC3 data part of the audio unit.

**SE2 (Spectral data Error flag no. two):** for MPEG-4 AAC stereo coding this is the error status of the right channel spectral data part; for MPEG-4 AAC mono, CELP and HVXC coding this flag is not used and shall have the value zero.

**ULS (Unspecified Less Sensitive error flag):** decoder dependent error flag for all other detected errors within the less sensitive part of the audio unit.

NOTE 1: The error flags "C", "SBR" and in case of MPEG-4 HVXC coding also "SE1" refer only to the pure CRC checks. Errors, which are located within the area protected by the CRC, but are detected otherwise in spite of apparently correct CRC, are signalled by the "UHS" or "ULS" error flags. For MPEG-4 AAC coding there exist two additional error flags for these unspecified errors to be a little bit more precise in terms of the error position.

NOTE 2: In the case of robustness mode E, useful "reas" data is only available in every alternate RSCI packet, since the audio super frame duration is twice the RSCI packet repetition rate; therefore the TAG length of the TAG item "reas" is zero for alternate packets (those where the FAC toggle parameter = 1).

#### 6.4.4 TAG items specifying DRM multiplex

For ease of reference the definition for TAG items "robm", "fac\_", "sdc\_", "sdci", "str0", "str1", "str2" and "str3" are copied from TS 102 820 [3]. In the case of differences the description in TS 102 820 [3] is valid.

### 6.4.4.1 Robustness mode (robm)

This TAG item, as shown in figure 6.19, shall be included in every RSCI TAG packet and is therefore mandatory for all RX\_STAT profiles. If the receiver is not in synchronization an empty TAG item shall be transmitted.

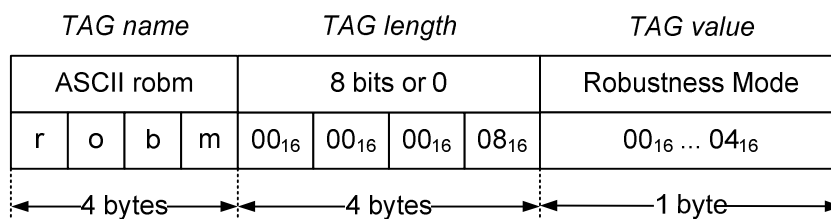

**Figure 6.19: Robustness mode**

**Robustness mode:** the current robustness mode as detected by the decoding algorithms.

The TAG value shall be encoded as given in table 6.2. All other values are reserved for future use.

**Table 6.2: Robustness mode encoding**

Value	Robustness mode
00 <sub>16</sub>	A
01 <sub>16</sub>	B
02 <sub>16</sub>	C
03 <sub>16</sub>	D
04 <sub>16</sub>	E

NOTE: The value of the "robm" TAG Item may be checked to identify whether RSCI Packets are scheduled to be transmitted every 400 ms (robustness modes A to D) or every 100 ms (robustness mode E).

### 6.4.4.2 Fast Access Channel (fac\_)

This TAG item as shown in figure 6.20 holds the complete FAC information as transmitted in the DRM multiplex and shall be included in every RSCI TAG packet. If no FAC information is available an empty TAG item shall be transmitted. This TAG item is mandatory for all RX\_STAT profiles except profile B.

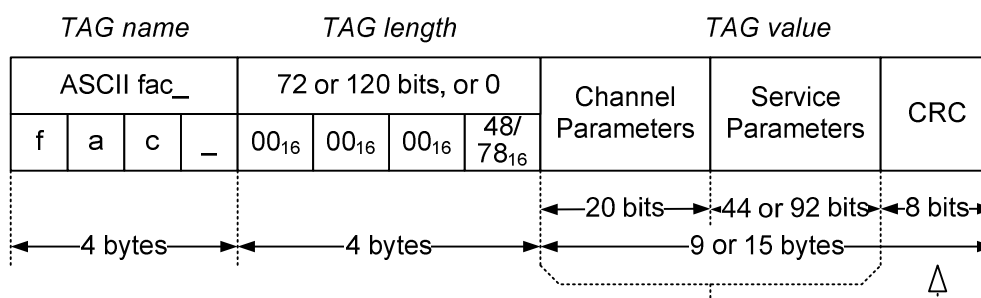

**Figure 6.20: Fast Access Channel**

**Channel parameters:** channel parameter section of the FAC as described in ES 201 980 [1], clause 6.3.3.

**Service parameters:** service parameter section of the FAC as described in ES 201 980 [1], clause 6.3.4 (the data carried in the service parameters section shall be repeated according to the FAC repetition rules described in ES 201 980 [1], clause 6.3.6). The length of this section depends on the robustness mode used: 44 bits (1 service description) for robustness modes A to D, or 92 bits (2 service descriptions of 44 bits each plus 4 padding bits set to 0) for robustness mode E.

**CRC:** checksum over the previous part of the TAG value as described in ES 201 980 [1], clause 6.3.5.

### 6.4.4.3 Service Description Channel (sdc\_)

As shown in figure 6.21 this TAG item holds one complete SDC block as transmitted in the DRM multiplex and shall be included in the TAG packet containing the data for the first logical frame of each super frame. The TAG length of this TAG item in any other TAG packets shall be zero. Because of the data rate this TAG item is mandatory only for RX\_STAT profiles A, C, D and R.

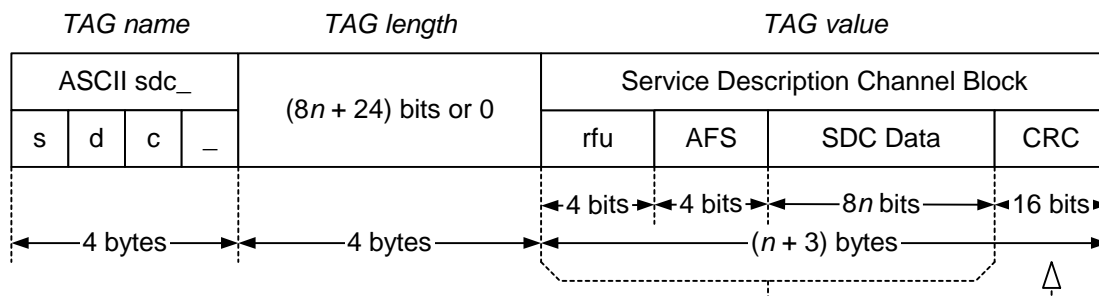

**Figure 6.21: Service Description Channel**

**rfu:** these four bits are reserved for future use and shall have the value zero.

NOTE 1: Bits 0 to 3 (most significant bits of the first byte of the TAG value which are bit positions 4 to 7 of the first byte) are padded with zeros to keep the byte alignment of the rest of the SDC data block.

**Alternative Frequency Switching (AFS):** index as described in ES 201 980 [1], clause 6.4.2.

**SDC Data:** data block of the SDC as described in ES 201 980 [1], clause 6.4.3.

**CRC:** checksum on the previous parts of the TAG value as described in ES 201 980 [1], clause 6.4.2.

The size of the SDC data block (value of  $n$ ) depends upon the robustness mode, constellation diagram used for SDC cells and spectrum occupancy of the DRM ensemble as described in ES 201 980 [1], clause 6.4.2, table 61 which lists values in the range of 13 to 207.

NOTE 2: If an SDC block is present in the actual transmission frame then the TAG length is calculated by (1 byte + SDC data size (in bytes) + 2 bytes CRC) otherwise the TAG length is zero.

### 6.4.4.4 Service Description Channel information (sdci)

The following TAG item provides the SDC multiplex description data entity - type 0 as shown in figure 6.22 and thus contains the complete multiplex description data of the DRM multiplex. This TAG item shall be included in every RSCI TAG packet of protocol streams using RX\_STAT profiles A, C, D, Q and R. If an TAG item "sdc\_" was sent, the TAG item "sdci" shall be transmitted also in the two frames where an empty TAG item "sdc\_" is transmitted (second and third transmission frame of a super frame).

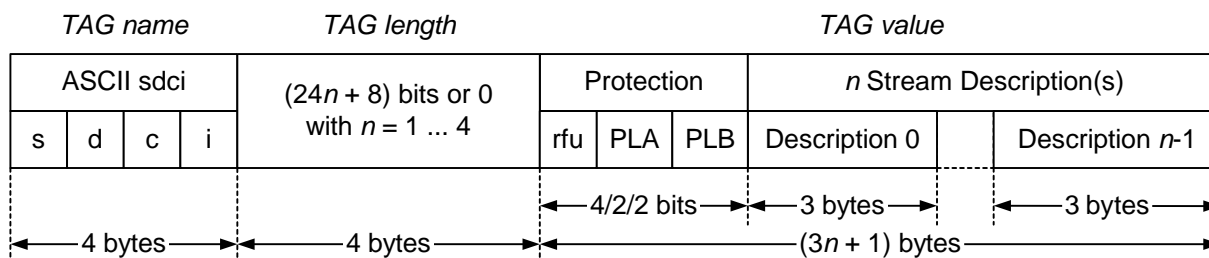

**Figure 6.22: Service Description Channel information**

**rfu:** these four bits are reserved for future use and shall have the value zero.

NOTE: Bits 0 to 3 (most significant bits of the first byte of the TAG value which are bit positions 4 to 7 of byte 0) are padded with zeros to keep the byte alignment of the rest of the SDC data entity block.

**PLA and PLB:** protection level as described in ES 201 980 [1], clause 7.5.1.

**Stream description:** stream description for an individual MSC stream as described in ES 201 980 [1], clause 6.4.3.1.

The first three-byte group holds the stream description for stream Id 0, ..., the fourth three-byte group holds the stream description for stream Id 3. Up to four stream descriptions may be included, the corresponding stream data is being carried in the RSCI "str0", "str1", "str2" and "str3" TAG items respectively (see clause 6.4.4.5).

#### 6.4.4.5 MSC stream data <n> (str0, str1, str2 and str3)

The TAG items "str0", "str1", "str2" and "str3" shall contain the MSC data for the corresponding DRM stream as shown in figure 6.23. If the TAG length is zero, the TAG item may be omitted from the TAG packet. Because of data rate reasons these TAG items are mandatory only for RX\_STAT profiles A, D and R.

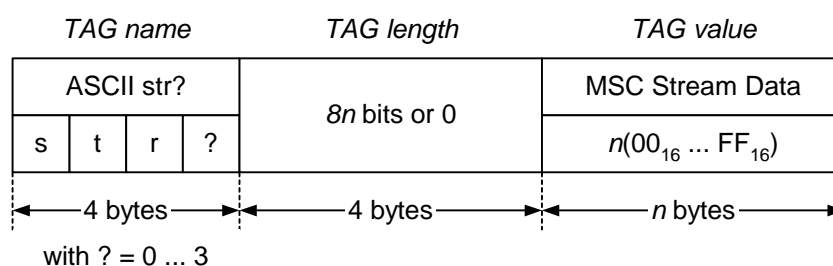

Figure 6.23: MSC stream data

The specific MSC stream is referred by use of the TAG name "str0", "str1", "str2" or "str3" appropriate to the stream Id.

**MSC stream data:** the content of one specific MSC stream present in the DRM multiplex.

The TAG length is the size of the MSC stream data in bits transported within one multiplex frame (see ES 201 980 [1], annex J).

NOTE 1: The collective maximum size of the four MSC streams is given by the maximum channel capacity for robustness mode A, spectrum occupancy 5 (= 20,0 kHz), 64-QAM, lowest protection level (code rate 0,78) with equal error protection which is 71 960 bits/s = 3 598 bytes/frame. This maximum amount of bytes can be spread in virtually any combination over the four available MSC streams (TAG items "str0" to "str3").

NOTE 2: The maximum number of bytes to be reserved for all four TAG items "str?" can be calculated by  $4 \times 8$  bytes of header + floor ((number of input bits L per multiplex frame given by ES 201 980 [1], annex J) / 8) bytes of data. The downward rounding is necessary because the last content nibble of the MSC cannot be used - the MSC content is always byte-aligned.

For the different timing (how the TAG content relates to that of the TAG items "fac\_" and "sdc\_") when using these TAG items in the case of long interleaving for RSCI RX\_STAT or MDI refer to clauses 5.3.1 and 5.4.

### 6.4.4.6 Gain reference pilots (rpil)

The cell values of the gain reference pilots are transported within an RSCI protocol stream using the TAG item "rpil" as shown in figure 6.24. This TAG item is mandatory for RX\_STAT profile D only because of the needed data rate, but shall be filled as soon as the FAC can be decoded. While the receiver is synchronizing or if the receiver is even not in synchronization an empty TAG item shall be transmitted.

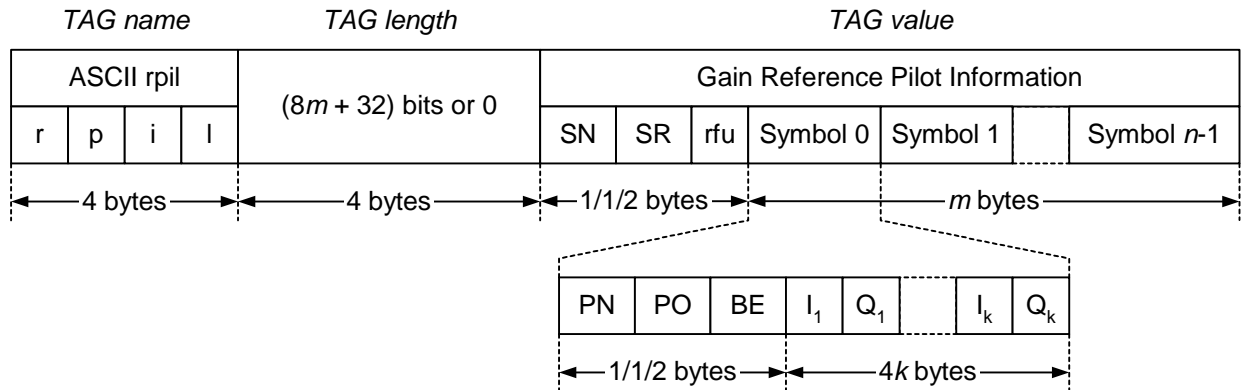

Figure 6.24: Gain reference pilots

**SN (Symbol Number):** number of symbols in this transmission frame as 8-bit unsigned integer value.

**SR (Symbol Repetition):** amount of symbols until the pilot pattern repeats as 8-bit unsigned integer value.

**rfu:** these two bytes are reserved for future use and shall have the value zero.

The values of the gain reference pilot cells are listed in the following pattern grouped by symbols 0 ... n-1 of one transmission frame:

**PN (Pilot Number):** number of pilots  $k$  in the actual symbol as 8-bit unsigned integer value.

**PO (Pilot Offset):** offset of the first pilot in relation to the lowest carrier number used in the actual robustness mode and spectrum occupancy as 8-bit unsigned integer value.

**BE (Block Exponent):** block exponent for all  $k$  pilot cell values of the actual symbol as 16-bit signed integer value.

**I<sub>1</sub>, Q<sub>1</sub>, ..., I<sub>k</sub>, Q<sub>k</sub>:** inphase and quadrature component of the received pilot cell values in order of the lowest to the highest carrier number as 16-bit signed integer values each.

The pilot cell values that are sent in this TAG item are the received pilot cell values, after the phase rotations and gain boosting applied in the modulator have been removed. No channel estimation is applied. In other words, a perfect receiver receiving a perfect transmission without any channel effects and distortion would only output pilot cell values of absolute value 1 due to the overall scaling factor.

The normalized pilot cell values can be re-calculated as:

$$I[\text{symbol}, \text{carrier}] / 32\,768 \times 2^{(\text{block\_exponent}[\text{Symbol}])} + j \times Q[\text{symbol}, \text{carrier}] / 32\,768 \times 2^{(\text{block\_exponent}[\text{Symbol}])}$$

In order to insure the highest resolution I<sub>1</sub>, Q<sub>1</sub>, ..., I<sub>k</sub>, Q<sub>k</sub> should be as close to +32 767 or -32 768 as possible.

NOTE 1: Where a frequency reference cell occupies a slot in the gain reference pattern, that pilot cell value is also output.

NOTE 2: A special case applies for the DC carrier of mode D: In symbols number 2, 5, 8, 11, 14, 17, 20, 23 a pilot with inphase and quadrature component value 0 has to be added at this position.

EXAMPLE 1: Taking robustness mode D, spectrum occupancy parameter 3 (= 10,0 kHz of channel bandwidth) as an example (see ES 201 980 [1], annex L), and using notation [symbol, carrier] the data stream would be:

$24_{10}$  (8-bit unsigned integer: symbol number)  
 $3_{10}$  (8-bit unsigned integer: symbol repetition)  
 $0_{10}$  (2 bytes reserved)  
 $30_{10}$  (8-bit unsigned integer: pilot number)  
 $0_{10}$  (8-bit unsigned integer: pilot offset)  
 BE[0] (16-bit signed integer: block exponent)  
 I[0, -44] Q[0, -44] I[0, -41] Q[0, -41]  
 ... I[0, -2] Q[0, -2] I[0, 1] Q[0, 1]  
 ... I[0, 40] Q[0, 40] I[0, 43] Q[0, 43]  
 $30_{10}$  (8-bit unsigned integer: pilot number)  
 $1_{10}$  (8-bit unsigned integer: pilot offset)  
 BE[1] (16-bit signed integer: block exponent)  
 I[1, -43] Q[1, -43] I[1, -40] Q[1, -40]  
 ... I[1, -1] Q[1, -1] I[1, 2] Q[1, 2]  
 ... I[1, 41] Q[1, 41] I[1, 44] Q[1, 44]  
 $29_{10}$  (8-bit unsigned integer: pilot number)  
 $2_{10}$  (8-bit unsigned integer: pilot offset)  
 BE[2] (16-bit signed integer: block exponent)  
 I[2, -42] Q[2, -42] I[2, -39] Q[2, -39]  
 ... I[2, -3] Q[2, -3] **I[2, 0]=0 Q[2, 0]=0** I[2, 3] Q[2, 3] (see note 2 for this special case)  
 ... I[2, 39] Q[2, 39] I[23, 42] Q[23, 42]  
 $30_{10}$  (8-bit unsigned integer: pilot number)  
 $0_{10}$  (8-bit unsigned integer: pilot offset)  
 BE[3] (16-bit signed integer: block exponent)  
 ... and so on for symbols number 3 to 24 ...

EXAMPLE 2: The maximum (worst case) data rate for the TAG item "rpil" is achieved with robustness mode D, spectrum occupancy 5 (= 20,0 kHz) with 1 424 gain reference pilot cells plus 8 zero values at DC carrier (see note 2) per transmission frame.

$1 \times 32$  bits (symbol number, symbol repetition, reserved bytes)  
 $+ 24$  (symbols/frame)  $\times 32$  bits (pilot number, pilot offset, block exponent)  
 $+ 1\ 432$  (pilot cells/frame)  $\times 2$  (I and Q)  $\times 16$  bits (pilot cell value)  
 $= 46\ 624$  bits/frame = 5 828 bytes/frame

$5\ 828$  bytes/frame / 0,4 s (duration of transmission frame) = 14 570 bytes/s

## 6.4.5 TAG items for results of measurements

The following TAG items are to transport the outcome of measurements for modulation and bit error rates, delay and Doppler estimation and power spectral density.

### 6.4.5.1 Weighted Modulation Error Ratio for FAC cells (rwmf)

This TAG item holds the Weighted Modulation Error Ratio (WMER) estimated by the receiver on the FAC cells of the current transmission frame and is mandatory for all RX\_STAT profiles except profile R. The dB-value of this error ratio is presented by this TAG item as shown in figure 6.25. If the receiver cannot calculate the WMER because the receiver is not in synchronization, an empty TAG item shall be transmitted.

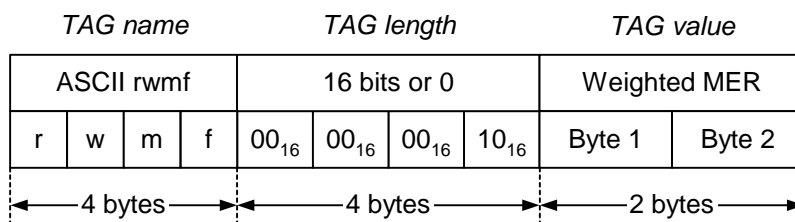

**Figure 6.25: Weighted Modulation Error Ratio for FAC cells**

**Weighted MER:** the format of this single value is  $(\text{Byte1} + \text{Byte2} / 256) = (\text{Byte1}.\text{Byte2})$  in [dB] with:

- Byte1 is an 8-bit signed integer value; and
- Byte2 is an 8-bit unsigned integer value.

NOTE: This is the same as to put Byte1 and Byte2 into a signed 16-bit integer value (Byte1 is the higher part) and to divide this value by 256.

The TAG value of the TAG item "rwmf" is calculated as follows: For each equalized FAC cell (no SDC cells, no MSC cells, no pilot cells), the error vector from the nearest ideal point of the constellation diagram is measured. The squared magnitude of this error is found, and a weighted mean of the squared errors is calculated over one frame. In calculating that mean, the squared error for each cell is multiplied by the squared magnitude of the estimated channel response for that cell. The sum of the weighted values is divided by the sum of the weights to give the weighted mean. The WMER is the ratio in [dB] of the mean of the squared magnitudes of the ideal points of the constellation diagram to the weighted mean squared error. This gives an estimate of the ratio of the total signal power to total noise power at the input of the equalizer.

$$WMER = 10 \log_{10} \left( \frac{\bar{S}_{\infty} \sum_k |c_k|^2}{\sum_k |c_k|^2 |s_k - r_k|^2} \right) \text{ with}$$

$c_k$  estimated channel responses.

$s_k$  optimal point values of the QAM constellation diagram (from hard decision).

$r_k$  received complex cell values after channel estimation.

$\bar{S}_{\infty}$  mean energy of used cells.

The mean energy  $\bar{S}_{\infty}$  used in this calculation is an average for all times, i.e. a constant and theoretical value. If a short time average is used, additional noise is added to the formula.

#### 6.4.5.2 Weighted Modulation Error Ratio for MSC cells (rwmm)

This TAG item holds the Weighted Modulation Error Ratio (WMER) estimated by the receiver on the MSC cells of the current transmission frame and is mandatory for all RX\_STAT profiles except profile R. The dB-value of this error ratio is presented by this TAG item as shown in figure 6.26. If the receiver cannot calculate the WMER because the receiver is not in synchronization, an empty TAG item shall be transmitted.

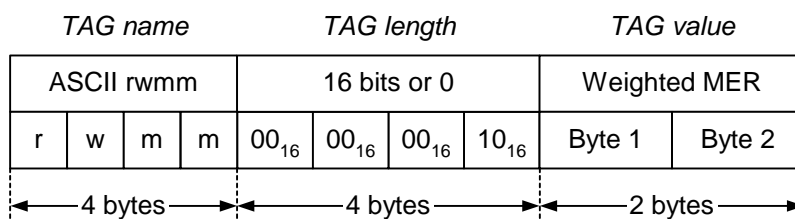
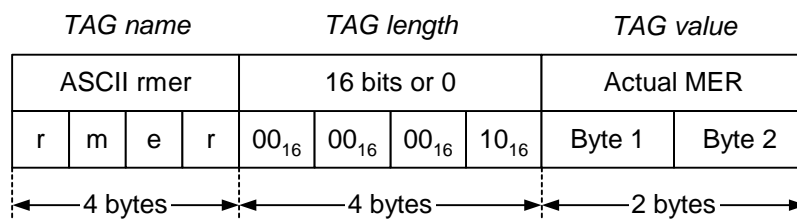

**Figure 6.26: Weighted Modulation Error Ratio for MSC cells**

For description and calculation of the TAG value see clause 6.4.5.1. Instead of the FAC cells now only the MSC cells are used.

### 6.4.5.3 Modulation Error Ratio for actual frame (rmer)

This TAG item holds the Modulation Error Ratio (MER) for the actual transmission frame and is mandatory for all RX\_STAT profiles. The dB-value of this error ratio is presented by this TAG item as shown in figure 6.27. If the receiver cannot calculate the MER because the receiver is not in synchronization, an empty TAG item shall be transmitted.



**Figure 6.27: Modulation Error Ratio for actual frame**

**Actual MER:** the format of this single value is  $(\text{Byte1} + \text{Byte2} / 256) = (\text{Byte1}.\text{Byte2})$  in [dB] with:

- Byte1 is an 8-bit signed integer value; and
- Byte2 is an 8-bit unsigned integer value.

NOTE: This is the same as to put Byte1 and Byte2 into a signed 16-bit integer value (Byte1 is the higher part) and to divide this value by 256.

The calculation of the TAG value for the TAG item "rmer" is described in TR 101 290 [i.1]. TR 101 290 [i.1] notes in annex C: "The MER can be regarded as a form of Signal-to-Noise ratio measurement that will give an accurate indication of a receiver's ability to demodulate the signal, because it includes, not just Gaussian noise, but all other *uncorrectable* impairments of the received constellation as well". This includes impairments of the signal by the transmitter.

The MER is calculated as follows: For each equalized MSC cell (only MSC cells, no FAC cells, no SDC cells, no pilot cells), the error vector from the nearest ideal point of the constellation diagram is measured. The squared magnitude of this error is found, and a mean of the squared errors is calculated over one frame. The MER is the ratio in [dB] of the mean of the squared magnitudes of the ideal points of the constellation diagram to the mean squared error. This gives an estimate of the ratio of the total signal power to total noise power at the input to the equalizer for channels with flat frequency response.

$$MER = 10 \log_{10} \left( \frac{\sum_k |s_k|^2}{\sum_k |s_k - r_k|^2} \right) \text{ with}$$

$s_k$  optimal point values of the QAM constellation diagram (from hard decision).

$r_k$  received complex cells values after channel estimation.

### 6.4.5.4 Bit error rate of MSC stream <n> (rbp0, rbp1, rbp2 and rbp3)

The Bit Error Rate (BER) of a specific MSC stream, which carries a PRBS sequence, is given by the following TAG item as shown in figure 6.28. This TAG item is mandatory for RX\_STAT profiles A, B, C, and D. If no MSC data is available, an empty TAG item shall be transmitted.



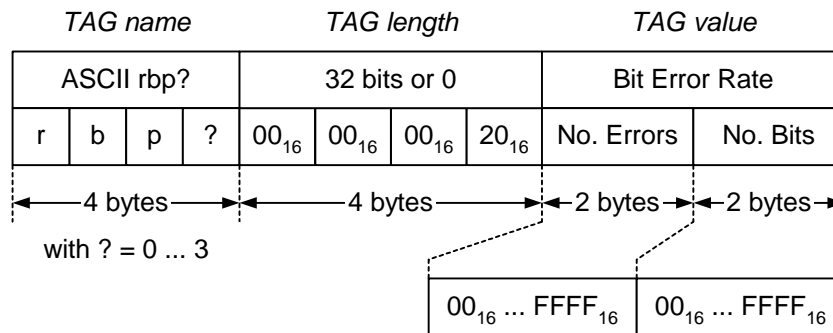

**Figure 6.28: Bit error rate of MSC stream <n>**

The specific MSC stream is referred by use of the TAG name "rbp0", "rbp1", "rbp2" or "rbp3" appropriate to the stream Id.

**No. errors:** number of erroneous bits in the MSC stream identified by stream Id 0 ... 3 of the current multiplex frame as 16-bit unsigned integer value.

**No. bits:** total number of received bits in the MSC stream identified by stream Id 0 ... 3 of the current multiplex frame as 16-bit unsigned integer value.

Please see clause 7 for details when to calculate the BER of an MSC stream.

#### 6.4.5.5 Delay window (rdel)

The following TAG item provides information of the delay window for a given percentage of signal energy as shown in figure 6.29. If the receiver is not in synchronization an empty TAG item shall be transmitted. This TAG item is mandatory for all RX\_STAT profiles except profile R.

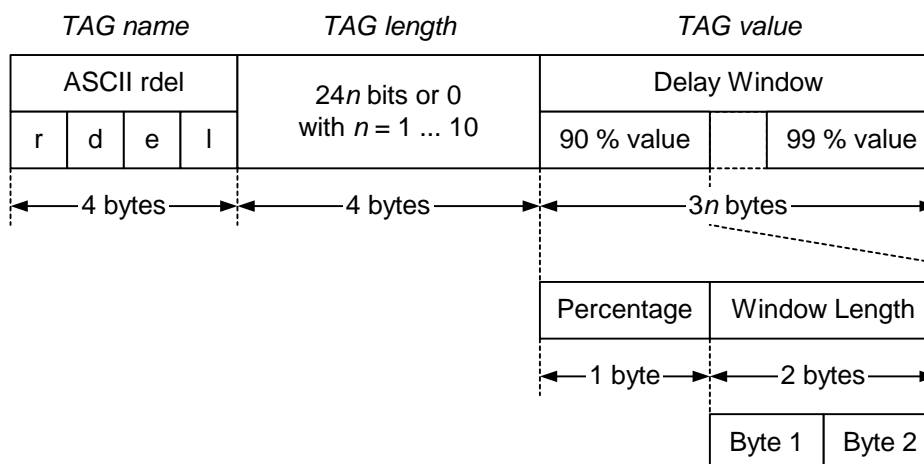

**Figure 6.29: Delay window**

The delay window for  $x$  % of signal energy shall be calculated and given as defined in ITU-R Recommendation P.1407 [6]. A multiple of three bytes represents the specific percentage of signal energy within the delay window and the length of the delay window as follows:

**Percentage:** the percentage [%] of signal energy within the delay window as 8-bit unsigned integer value.

**Window length:** the format of this value is (Byte1 + Byte2 / 256) = (Byte1.Byte2). For robustness modes A to D the time is given in ms, and for robustness mode E the time is given in  $\mu$ s with:

- Byte1 is an 8-bit unsigned integer value; and
- Byte2 is an 8-bit unsigned integer value.

NOTE: This is the same as to put Byte1 and Byte2 into a signed 16-bit integer value (Byte1 is the higher part) and to divide this value by 256.

The first three-byte group represents the mandatory 90 % energy window. An arbitrary number of optional three-byte groups (up to a maximum of nine additional groups) can follow the mandatory three-byte group. Suggested values are for 95 % and 99 % of the signal energy, which results in nine bytes of TAG value. The maximal TAG length is 30 bytes for ten three-byte groups.

The calculation of the energy percentages is done on the sum of the squared absolute values of the estimated impulse responses of all symbols in a transmission frame. Estimation implies filtering and interpolation between successive symbols. The steps of calculation are as follows:

- 1) estimate the complex cell gains for the current symbol for all carriers, where gain reference pilots are available, using interpolation or filtering mechanisms;
- 2) calculate the impulse response by using the estimated complex cell gains;
- 3) calculate the squared absolute values of the complex impulse response values;
- 4) sum up the values from step 3 for each carrier in all symbols of a transmission frame - the result is an averaged impulse response;
- 5) calculate the total energy  $P_{\text{total}}$  by summing up the averaged impulse response;
- 6) step from each border of the averaged impulse response inwards as long as the desired threshold  $P_{\text{th}}$  (the given percentage of the total energy  $P_{\text{total}}$ ) is not reached or exceeded:  $P_{\text{th}} = P_{\text{total}} \cdot (1 - x / 100) / 2$ ;
- 7) calculate the delay value from the distance of the two detected positions.

#### 6.4.5.6 Doppler estimation (rdop)

With the TAG item "rdop" a value of Doppler estimation on the received signal is transported as shown in figure 6.30. If the receiver is not in synchronization an empty TAG item shall be transmitted. This TAG item is mandatory for all RX\_STAT profiles except profile R.

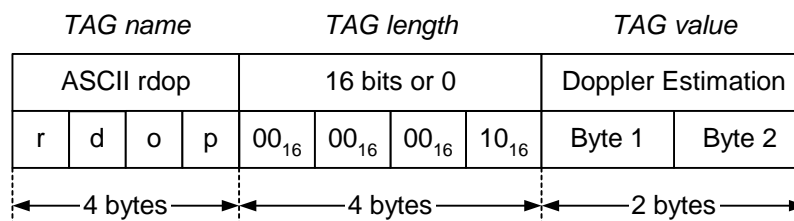

Figure 6.30: Doppler estimation

**Doppler estimation:** the format of this value is  $(\text{Byte1} + \text{Byte2} / 256) = (\text{Byte1}.\text{Byte2})$  in [Hz] with:

- Byte1 is an 8-bit unsigned integer value; and
- Byte2 is an 8-bit unsigned integer value.

NOTE 1: This is the same as to put Byte1 and Byte2 into a signed 16-bit integer value (Byte1 is the higher part) and to divide this value by 256.

The Doppler estimation measures the vector change, from one symbol to the next, in the individual paths making up the impulse response. The estimate is an average rate of rotation calculated as though the vector change were normal to the path in each case. Hence a path whose phase is constant but whose amplitude is changing will also give a fairly representative contribution. Small angle approximations are applied, i.e. the estimate assumes that the Doppler is slow compared to the symbol rate. Every frame an average of all symbols within that frame is sent.

NOTE 2: A factor of two is included so that the estimate is of the two-sided range of Doppler shifts. A channel with two equal paths, whose Doppler shifts are +1 Hz and -1 Hz respectively, will give a reading of 2 Hz.

For channels with Doppler spread, the estimate will reflect the instantaneous rate at which the channel is changing, possibly giving an explanation for audio dropouts. The Doppler spread itself is a long-term statistical property of the channel and we make no claim to estimate it.

The Doppler estimation is calculated as follows:

- 1) start with estimates of the complex impulse response from two successive symbols (symbols  $n-1$  and  $n$ );
- 2) take the difference between corresponding samples in the two estimates;
- 3) find the square root of the sum of the squares of magnitudes of these differences - this is the "RMS difference";
- 4) find the square root of the sum of the squares of magnitudes of the samples of the complex impulse response estimate for the more recent symbol (symbol  $n$ ) - this is the "RMS magnitude";
- 5) divide the RMS difference by the RMS magnitude, divide the result by  $\pi$  and multiply by the symbol rate for the current mode.

The calculation of the TAG value for the TAG item "rdop" is expressed by the following formula:

$$rdop = \frac{1}{\pi T_s} \frac{\sqrt{\sum_i |h_n(i) - h_{n-1}(i)|^2}}{\sqrt{\sum_i |h_n(i)|^2}} \text{ with}$$

$h_n(i)$  is the  $i$ -th sample of the complex impulse response estimate for symbol  $n$ .

NOTE 3: It is easy to understand the rationale behind the method by considering the above procedure applied to the impulse response. However, the same answer could be obtained by applying the same procedure to the estimated frequency response. This is because the Fourier Transformation is linear, hence the difference between transformations is equal to the transformation of the difference. Additionally Parseval says, the sum of squares in the frequency domain is  $k^2 \cdot$  (sum of squares in time domain). The result above is based on the ratio of two sums of squares, so the gain factor  $k$  of the Fourier Transformation cancels out.

#### 6.4.5.7 Power Spectral Density (rpsd)

The last TAG item of the measurements section is one which holds the values of the Power Spectral Density (PSD) of the received signal as shown in figure 6.31. Only in case that no input signal is available, an empty TAG item shall be transmitted. Because of data rate reasons this TAG item is mandatory for RX\_STAT profiles A and D only.

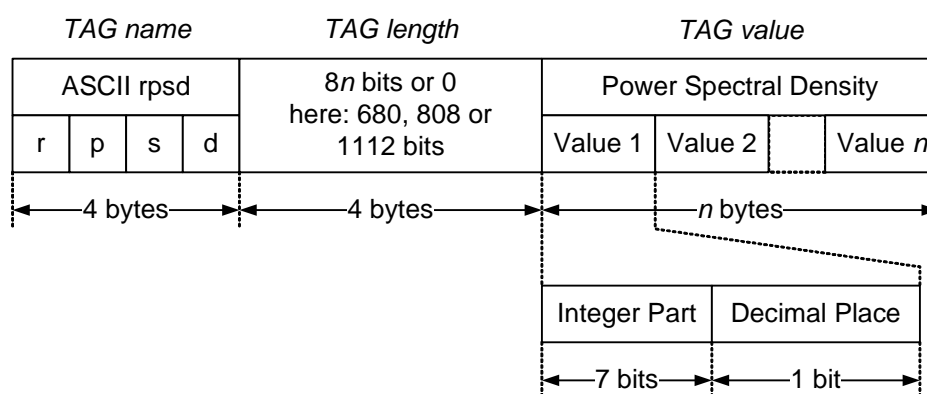

Figure 6.31: Power Spectral Density

Each single value of the Power Spectral Density (PSD) is of the following format:

**Power Spectral Density value  $n$ :** one 8-bit byte per value with:

- **Integer part:** 7 bits (most significant bits of the byte) for the absolute integer value of the calculated negative floating point PSD value.
- **Decimal place:** 1 bit (LSb) for the rounded decimal place in steps of 0,5 dB of the calculated floating point PSD value.

Therefore the covered PSD signal range is -127,0 dB ( $FE_{16}$  in terms of the TAG value) to 0,0 dB ( $00_{16}$ ).

If a receiver is not capable of evaluating the PSD for each of the described frequencies (see below), the value for all not calculated or invalid frequencies shall be set to  $FF_{16}$  (-127,5 dB) as special case of the TAG value. If some values are valid but calculated to be lower than -127,0 dB, they have to be limited to the minimum of -127,0 dB ( $FE_{16}$ ).

The values are generated by performing a one-dimensional FFT on the IQ input signal with a frequency spacing of 187,5 Hz for robustness modes A to D and 1,5 kHz for robustness mode E. The FFT uses Hanning windowing. This gives a resolution bandwidth of 281,25 Hz in robustness modes A to D and 2,25 kHz in robustness mode E. The sampling is done using 50 % overlap. This results in 150 FFTs per transmission frame for robustness modes A to D and 300 FFTs per transmission frame for robustness mode E.

For generation of one "rpsd" TAG item for one transmission frame, all the frequency energy output values of the FFTs are averaged. The FFT energy values are upscaled by a factor of 4 because of windowing and downscaled (divided) by the number of windows per frame which is 150 for robustness modes A to D and 300 for robustness mode E.

$$PSD(f) = 10 \log_{10} \left( \frac{4}{150} \sum_i |FFTvalue(f)|^2 \right) \text{ for robustness modes A to D, or}$$

$$PSD(f) = 10 \log_{10} \left( \frac{4}{300} \sum_i |FFTvalue(f)|^2 \right) \text{ for robustness mode E.}$$

**EXAMPLE 1a:** By the use of an IQ input signal (sampling frequency 48 kHz, robustness modes A to D,) this results in a complex 256-point FFT running 150 times for one frame (19 200 complex samples per frame with 50 % overlap equals 38 400 complex samples; 38 400 samples / 256 FFT taps = 150).

**EXAMPLE 1b:** By the use of an IQ input signal (sampling frequency 192 kHz, robustness mode E,) this results in a complex 128-point FFT running 300 times for one frame (19 200 complex samples per frame with 50 % overlap equals 38 400 complex samples; 38 400 samples / 128 FFT taps = 300).

The number of values put in the TAG value of this TAG item is restricted to the values out of a frequency range seen from the DC-carrier of -8/+8 kHz for the half and full bandwidth DRM transmission modes (4,5 kHz, 5 kHz, 9 kHz, and 10 kHz nominal bandwidth), -8/+18 kHz for the double bandwidth DRM transmission modes (18 kHz and 20 kHz nominal bandwidth) and -75/+75 kHz for robustness mode E (96 kHz bandwidth).

**EXAMPLE 2a:** By the use of an IQ input signal (sampling frequency 48 kHz, robustness modes A to D) this results in 85 values (-42 FFT-lines, DC, +42 FFT-lines or -7 875 kHz to +7 875 kHz in steps of 187,5 Hz) for half or full bandwidth modes and 139 values (-42 FFT-lines, DC, +96 FFT-lines or -7 875 kHz to +18 000 kHz in steps of 187,5 Hz) for double bandwidth modes. The DC-carrier is value number 43 in both cases.

**EXAMPLE 2b:** By the use of an IQ input signal (sampling frequency 192 kHz, robustness mode E) this results in a number of 101 values (-50 FFT-lines, DC, +50 FFT-lines or -75 kHz to +75 kHz in steps of 1,5 kHz).

#### 6.4.5.8 Narrow Band Interferer (rnic) constellation based

This TAG item as shown in figure 6.32 is one of two TAG items which can be used to detect the presence of a narrow band interferer. The method used in this TAG item is based on the received constellation, whereas that used by the "rnip" TAG item is based on the estimated input Power Spectral Density (PSD).

The method used in this TAG item is more sensitive to low-level interferers falling within the signal bandwidth, but will not for example detect carriers falling at  $\pm 5$  kHz from the reference frequency in 10 kHz mode.

Only in case that no input signal is available, an empty TAG item shall be transmitted. In robustness mode E, an empty TAG item shall be transmitted. This TAG item is mandatory for RX\_STAT profiles A, B, C and D.

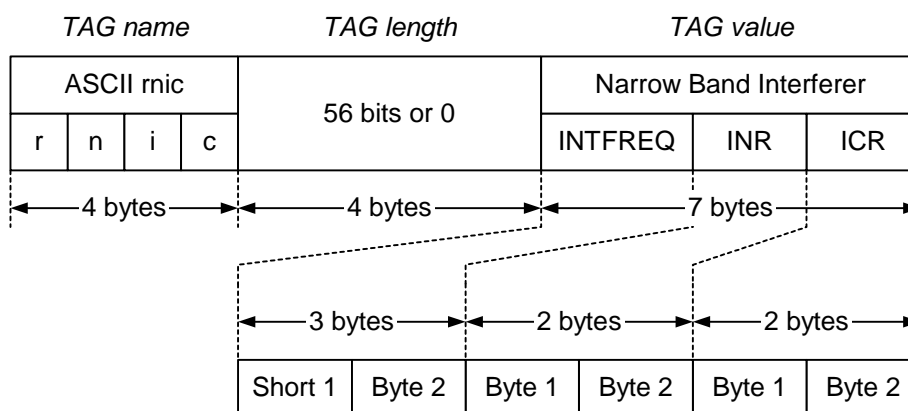

**Figure 6.32: Narrow Band Interferer constellation based**

Each single value of the narrow band interferer is of the following format:

**Interference Frequency (INTFREQ):** this value gives the interference frequency relative to the reference ("DC") frequency using the format  $(\text{Short1} + \text{Byte2} / 256) = (\text{Short1}.\text{Byte2})$  in [Hz] with:

- Short1 is a 16-bit signed integer value; and
- Byte2 is an 8-bit unsigned integer value.

NOTE 1: This is the same as to put Short1 and Byte2 into a signed 24-bit integer value (Short1 is the higher part) or into the lower three bytes of a signed 32-bit integer value (Short1 is the higher part, setting the MSB to  $00_{16}$  or  $FF_{16}$  whether Short1 is positive or negative) and to divide this value by 256.

**Interference-to-Noise Ratio (INR):** this value gives the interference level relative to the average noise level using the format  $(\text{Byte1} + \text{Byte2} / 256) = (\text{Byte1}.\text{Byte2})$  in [dB] with:

- Byte1 is an 8-bit unsigned integer value; and
- Byte2 is an 8-bit unsigned integer value.

NOTE 2: This is the same as to put Byte1 and Byte2 into an unsigned 16-bit integer value (Byte1 is the higher part) and to divide this value by 256.

This value will always be positive by virtue of the way it is defined.

**Interference-to-Carrier Ratio (ICR):** this value gives the interference level relative to the average power of a single carrier using the format  $(\text{Byte1} + \text{Byte2} / 256) = (\text{Byte1}.\text{Byte2})$  in [dB] with:

- Byte1 is an 8-bit signed integer value; and
- Byte2 is an 8-bit unsigned integer value.

NOTE 3: This is the same as to put Byte1 and Byte2 into a signed 16-bit integer value (Byte1 is the higher part) and to divide this value by 256.

The calculation of the three fields is done as follows:

For each equalized cell (MSC, FAC or SDC), the error vector from the nearest ideal constellation point is measured. The squared magnitude of this error is found, and is multiplied by the squared magnitude of the estimated channel response for that cell (notation as in clause 6.4.5.1):

$$e_k = |c_k|^2 |s_k - r_k|^2$$

For each carrier, a decaying average is maintained of these weighted error values. The forgetting factor used in calculating the average is  $\alpha = 0,125$ . Each symbol, the new average value is calculated from the old value as follows:

$$i_k^{\text{new}} = (1 - \alpha) \cdot i_k^{\text{old}} + \alpha \cdot e_k$$

Once per frame, the carrier with the greatest decaying average value is found. Its frequency is calculated in [Hz] relative to the carrier zero ("DC") and this forms the "interference frequency" field of the TAG:

$$INTFREQ = \frac{1}{T_u} \operatorname{argmax}_k(i_k),$$

where  $T_u$  is the active symbol period so that  $1/T_u$  is the carrier spacing.

NOTE 4: Single tone interferers located exactly on carrier frequencies without equalized data cells may not or not correctly be detected by this TAG item. These frequencies are the DC carrier and the continuous frequency references at 750 Hz, 2 250 Hz and 3 000 Hz above the DC carrier.

The average across all carriers of the decaying averages is calculated. The decaying average value on the carrier identified above is expressed in dB relative to the average across all carriers. This indicates the approximate "interference-to-noise ratio": By how much the interference level on the "interfered" carrier is worse than the overall average SNR. A large value suggests narrowband interference is present, whereas a lower value indicates that all carriers are subject to a similar level of disturbance, i.e. noise or broadband interference.

$$INR = 10 \log_{10} \left( \frac{\max_k(i_k)}{\frac{1}{K} \sum_k i_k} \right),$$

where  $K$  is the number of carriers.

The ratio of the power of the interferer to the average power of a single carrier is also estimated:

$$ICR = 10 \log_{10} \left( \frac{\max_k(i_k)}{\bar{S}_\infty \frac{1}{K} \sum_k |c_k|^2} \right),$$

where  $\bar{S}_\infty$  is the long-term average cell energy as defined in clause 6.4.5.1.

#### 6.4.5.9 Narrow Band Interferer (rnp) power spectral density based

This TAG item as shown in figure 6.33 is one of two TAG items which can be used to detect the presence of a narrow band interferer. The method used in this TAG item is based on the estimated input Power Spectral Density (PSD), whereas that used by the "rnic" TAG item is based on the received constellation.

The method used in this TAG item is less sensitive to in-band interferers, but gives better results for interferers at  $\pm 5$  kHz and at 0 Hz from the reference frequency in 10 kHz mode. The information given by this method can be entirely derived from the TAG item "rpsd", but this tag shows the presence, size and frequency of an interferer more directly and requires a much lower data rate, so it is suitable for inclusion in lower bit-rate profiles of RSCI. Therefore this TAG item is mandatory for RX\_STAT profiles A, B, C and D. In robustness mode E, an empty TAG item shall be transmitted.

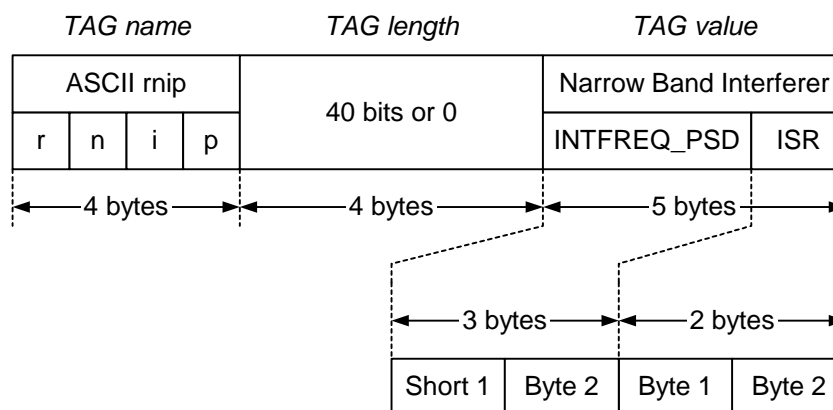

**Figure 6.33: Narrow Band Interferer power spectral density based**

These fields are based on the Power Spectral Density PSD(f) calculated as described for the TAG item "rpsd" (see clause 6.4.5.7).

**Interference Frequency (INTFREQ\_PSD):** this value gives the interference frequency relative to the reference ("DC") frequency using the format (Short1 + Byte2 / 256) = (Short1.Byte2) in [Hz] with:

- Short1 is a 16-bit signed integer value; and
- Byte2 is an 8-bit unsigned integer value.

NOTE 1: This is the same as to put Short1 and Byte2 into a signed 24-bit integer value (Short1 is the higher part) or into the lower three bytes of a signed 32-bit integer value (Short1 is the higher part, setting the MSB to  $00_{16}$  or  $FF_{16}$  whether Short1 is positive or negative) and to divide this value by 256.

**Interference-to-Signal Ratio (ISR):** this value gives the interference level relative to the total power in the bandwidth corresponding to the TAG item "rpsd" using the format (Byte1 + Byte2 / 256) = (Byte1.Byte2) in [dB] with:

- Byte1 is an 8-bit signed integer value; and
- Byte2 is an 8-bit unsigned integer value.

NOTE 2: This is the same as to put Byte1 and Byte2 into a signed 16-bit integer value (Byte1 is the higher part) and to divide this value by 256.

The calculation of the two fields is done as follows:

The bin of PSD(f) with the greatest value is found. Only bins which would be included in the TAG item "rpsd" are taken into account. The INTFREQ\_PSD field is the frequency in Hz corresponding to the centre of this bin, expressed relative to the nominal reference frequency. That is, the calculation does not take into account the current estimated frequency error.

The total power in all the bins of PSD(f) that would be included in the TAG item "rpsd" is also calculated, and the power in the bin identified as the greatest is expressed relative to this total power:

$$ISR = \max_f(PSD_f) - 10 \log_{10} \left( \sum_{f \in F_{rpsd}} 10^{\frac{PSD(f)}{10}} \right)$$

where  $F_{\text{rpsd}}$  is the set of frequencies included in the TAG item "rpsd". Note that the powers, not the dB values, are summed.

### 6.4.5.10 Power Impulse Response (rpir)

This TAG item gives sample values of the estimated Power Impulse Response. If no power impulse response is available, e.g. because the receiver is not synchronized, an empty TAG item may be sent.

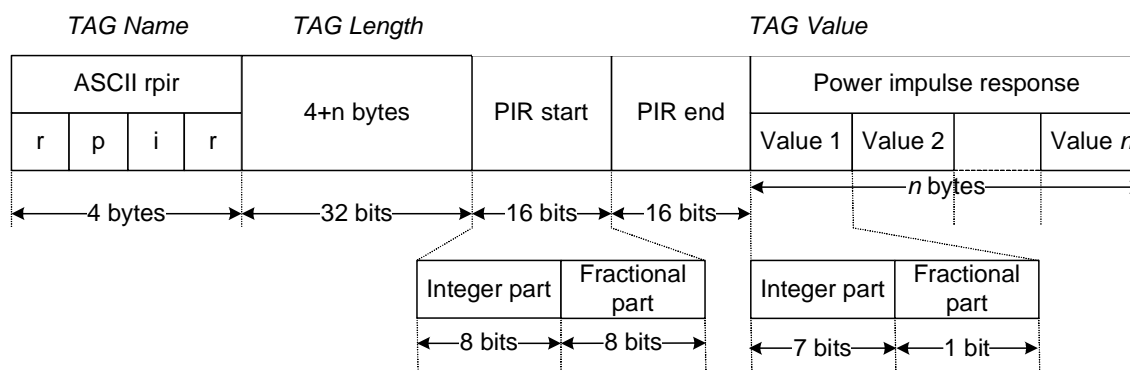

Figure 6.33a

The PIR start and PIR end fields give the start and end times for the impulse response, in milliseconds for robustness modes A to D and in microseconds for robustness mode E. Both fields are 16 bits, comprised of a signed integer part and unsigned fractional part. The time in milliseconds is given by  $(\text{Integer Part} + \text{Fractional Part} / 256)$ . The reference point is arbitrary, e.g. the start and end may be symmetrically placed around zero or the start may be set to zero.

The Value fields give evenly spaced samples of the estimated power impulse response in time order, with Value 1 corresponding to PIR start and Value  $n$  corresponding to PIR end.

The number of samples, and the range PIR start .. PIR end, may be chosen by the receiver implementer. The maximum number of samples  $n$  shall be 256.

Each Value field comprises a 7-bit unsigned Integer part and a 1-bit fractional part. The PIR value in dB is given by:

- $\text{PIR sample} = - (\text{Integer Part} + \text{fractional part} / 2)$ .

A constant scaling factor shall be applied to ensure that the values fall within the range -127,5 to 0.

## 6.4.6 TAG items for analogue reception

### 6.4.6.1 Encoded analogue-mode audio (rama)

This TAG item contains encoded.

If one of the standard DRM coders is used:

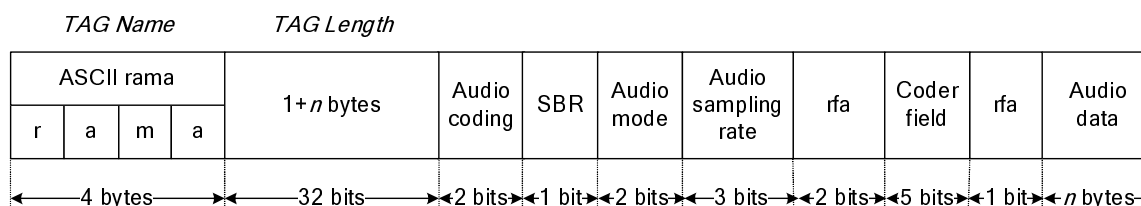

Figure 6.33b

The Audio coding, SBR, Audio mode, Audio sampling rate and coder fields are exactly as defined for SDC data entity 9.



The Audio data field contains one audio super frame of data coded according to the specified codec.

If audio coding =  $11_2$ , the TAG is defined as follows.

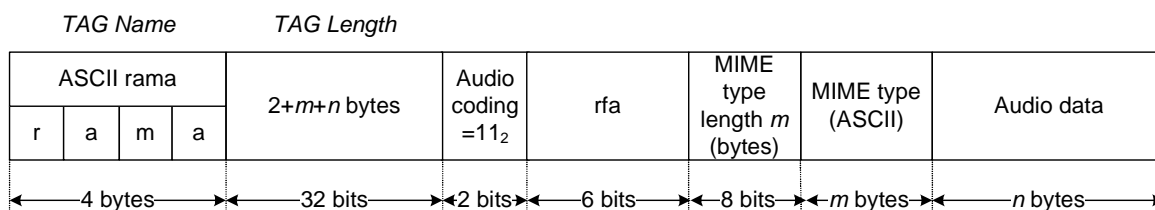

Figure 6.33c

## 6.4.7 TAG items specifying longer-term statistics

A number of TAG items are defined to provide statistic information on the variation of some receiver measurements over a period of time. These TAG items need not be sent every DRM transmission frame and may therefore be used over lower bit-rate or high cost-per-bit links in order to reduce the amount of data transferred.

Some of the statistics TAG items begin with "x" and are derived in a uniform way from one of the other TAG items specified in clause 6.4. For providing statistical information on other measurements, specific TAG items are defined; these do not begin with "x".

### 6.4.7.1 Statistics derived from other TAG items

#### 6.4.7.1.1 General format of derived statistics TAG items

The TAG format for a derived statistics TAG item is as shown below:

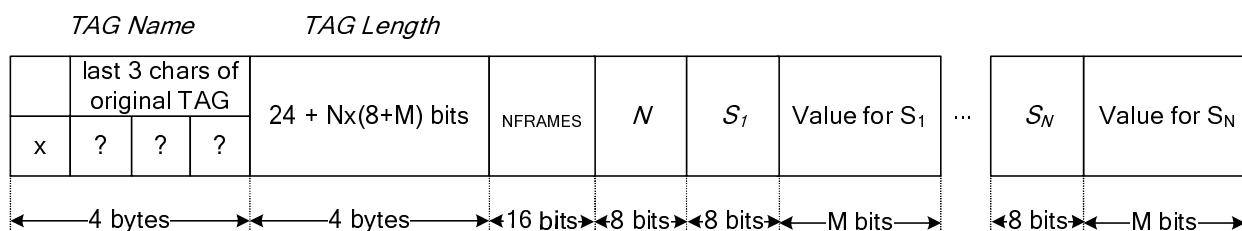

Figure 6.33d

The first letter of the TAG Name shall be "x" to indicate a statistics tag. The remaining 3 bytes, when the letter "r" is prepended, indicate the name of the normal TAG item from which this is derived (for example, the statistics TAG item "xmer" is derived from the "rmer" TAG item).

**NFRAMES:** indicates the number of DRM transmission frames over which the statistics were measured.

**N:** indicates the number of different statistics which the TAG contains.

There then follows the statistics.

**S:** indicates which statistic is conveyed, as follows:

- 0-100: indicates the percentile represented by the corresponding value
- 0: minimum value (a special case of a percentile)
- 100: maximum value (a special case of a percentile)
- 101: mean value

- 102: sample standard deviation
- Other: reserved

**Value:** this portion contains the statistical values themselves, using exactly the same format as defined for the corresponding tag. The specified statistic shall not necessarily be calculated on every field of the original TAG item; the exact treatment for each TAG item and field is specified in clauses 6.4.7.1.2 onwards.

For all tags, including those expressed in dB, the mean and standard deviation shall be calculated based on the numerical representation in the corresponding tag.

#### 6.4.7.1.2 TAG items based on dB values (xdbv, xwmf, xwmm, xmer)

The TAG items xdbv, xwmf, xwmm and xmer are derived from the rdbv, rwmf, rwmm and rmer TAG items respectively as described in clauses 6.4.2.3 and 6.4.5. The statistics are calculated directly on dB values.

NOTE: Calculating the mean and standard deviation in this way corresponds to the common assumption that the variables follow a log-normal distribution.

#### 6.4.7.1.3 Delay statistics (xdel)

This TAG item is derived from the "rdel" TAG item as described in clause 6.4.5.5. The statistics are calculated on the "window length" field.

#### 6.4.7.1.4 Doppler statistics (xdop)

The xdop TAG item is derived from the "rdop" TAG item as described in clause 6.4.5.6. The statistics are calculated on the "Doppler estimation" value in Hertz.

#### 6.4.7.1.5 Power Spectral Density and Power Impulse Response statistics (xpsd, xpir)

The TAG items xpsd and xpir are derived from the rpsd (see clause 6.4.5.7) and rpir (see clause 6.4.5.10) TAG items respectively.

The statistics are calculated individually on each "value", i.e. each bin of the relevant analysis.

NOTE: Calculation of the median and other percentiles might be memory- and processor-intensive and receivers may for example provide only minimum, maximum, mean and standard deviation values.

#### 6.4.7.1.6 Narrowband interference statistics (xnip, xnic)

The TAG items xnip and xnic are derived from the rnic (see clause 6.4.5.8) and rnip (see clause 6.4.5.9) TAG items respectively. The interference frequency (INTFREQ and INTFREQ\_PSD respectively) in the statistics TAG shall contain the most commonly detected value of the corresponding field in the rnic or rnip TAG over the measurement period. The other fields shall contain the indicated statistical value.

### 6.4.7.2 Statistics not derived from other TAG items

#### 6.4.7.2.1 Receiver status statistics (rsst)

This TAG item indicates the overall statistics of the receiver status (corresponding to the rsta TAG item) over a period of time.

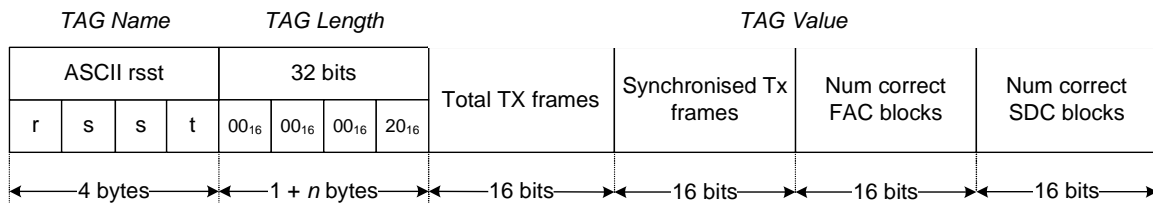

Figure 6.33e

**Total TX Frames:** the number of transmission frames that should have been received in the time.

**Synchronised Tx frames:** the number of transmission frames for which the receiver was synchronized.

**Num correct FAC blocks:** the number of correctly received FAC blocks (as defined in rsta TAG item).

**Num correct SDC blocks:** the number of correctly received SDC blocks (as defined in rsta TAG item).

NOTE: Statistics for the audio status, which also appears in the rsta TAG item, is dealt with separately by the rast TAG item.

#### 6.4.7.2.2 Audio quality statistics (rast)

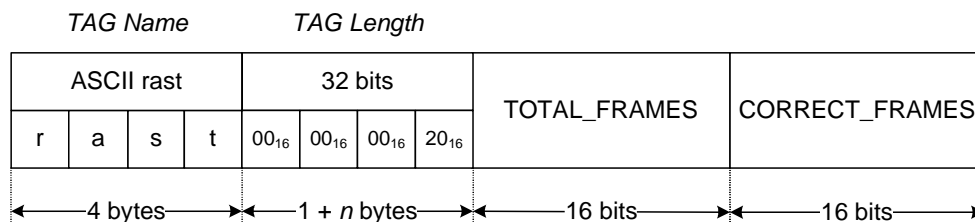

Figure 6.33f

Indicates the overall audio frame statistics over a period of time.

**TOTAL\_FRAMES:** total number of audio frames which should have been received during the measurement period.

**CORRECT\_FRAMES:** number of error-free audio frames received during the measurement period.

## 6.5 TAG items for RX\_CTRL

The TAG items within the following clauses are defined for RX\_CTRL communication.

TAG packets comprising RX\_CTRL TAG items with commands for the receiving unit:

- can be sent to the receiver at any time;
- need to be sent only at the point of time some parameters are to be changed;
- do not include any counter like the RX\_STAT TAG packets; and
- shall be processed by the receiver before sending out a new RX\_STAT TAG packet. If the receiver is currently sending out a RX\_STAT TAG packet at the moment of arrival of the RX\_CTRL TAG packet, the commands will not affect the actual RX\_STAT TAG packet but first the next one.

All mandatory TAG items of the RX\_CTRL profile currently used shall be understood, interpreted and executed by the receiver. All other TAG items - optional or recommended - may be understood, interpreted and executed or skipped as unknown ones.

NOTE: A receiver which is titled to be compliant to a specific RX\_CTRL profile is therefore able to process at least all TAG items marked as mandatory for this RX\_CTRL profile. Or the other way round: A receiver capable of processing at least all mandatory TAG items of a specific RX\_CTRL profile may be titled compliant to this RX\_CTRL profile.

If the TAG value of a TAG item has a fixed size then the size is given at the point TAG length. Some of the TAG items have variable data length due to a variable size of the TAG value. This is indicated by the expression "variable". The length is then given in the TAG value description. For some TAG items the TAG value may sometimes not be available. Such TAG items are marked by "or 0" at the point TAG length.

The communication is uni-directional.

The receiver is listener only. The reception of a RX\_CTRL TAG packet is not acknowledged by the receiver, but can be controlled implicit by looking at the changes of the RX\_STAT data that do appear or even not.

## 6.5.1 TAG items for receiver settings

The following TAG items are to set the demodulation type and frequency for the transmission which is intended to be received and which service the receiver should listen to.

### 6.5.1.1 Activate receiver (cact)

To set the receiving equipment in active state or standby for reception the following TAG item is used as shown in figure 6.34. This TAG item is mandatory for all RX\_CTRL profiles.

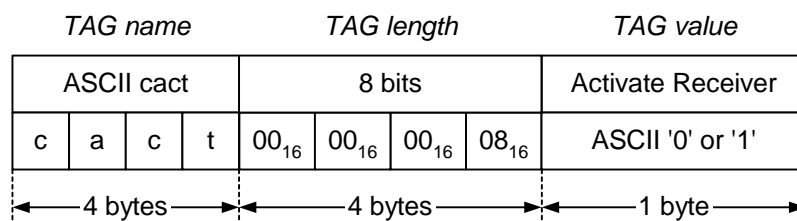

Figure 6.34: Activate receiver

**Activate receiver:** this ASCII character gives the desired active status for the reception equipment as follows:

ASCII "0"	deactivate
ASCII "1"	activate

### 6.5.1.2 Set reception frequency (cfre)

To set the reception frequency for the current transmission the TAG item "cfre" is used as shown in figure 6.35. This most important RX\_CTRL TAG item is mandatory for all RX\_CTRL profiles.

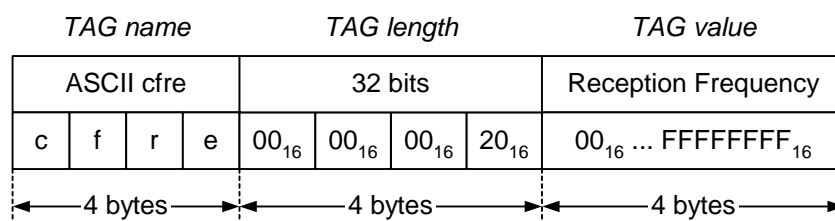

Figure 6.35: Set reception frequency

**Reception frequency:** 32-bit unsigned integer value in [Hz].

The receiver should set the reception frequency of the HF front-end as close to this frequency value as possible.

### 6.5.1.3 Set receiver demodulation type (cdmo)

This TAG item signals the demodulation type to be used to the receiver in ASCII notation as shown in figure 6.36 and is mandatory for all RX\_CTRL profiles. See also TAG item "rdmo" at clause 6.4.2.1.

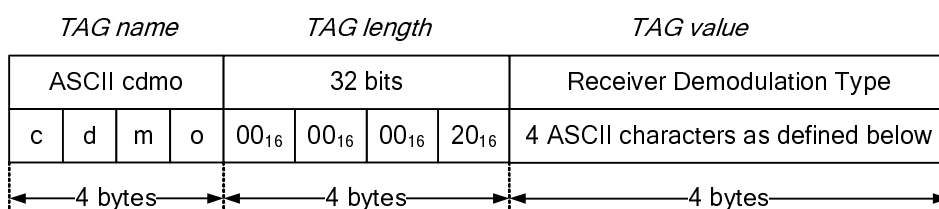

**Figure 6.36: Set receiver demodulation type**

The information on the demodulation type for the receiver to be used is given as four ASCII characters:

drm_	DRM demodulation (robustness modes A to D)
drm+	DRM demodulation (robustness mode E)
am_	AM demodulation
usb_	Upper Side Band demodulation
lsb_	Lower Side Band demodulation
sam_	Synchronous AM demodulation
nbfm	Narrowband FM demodulation (i.e. communications-band FM)
wbfm	Wideband FM demodulation (i.e. broadcast-band FM)

### 6.5.1.4 Set IF filter bandwidth (cbws and cbwg)

The IF filter bandwidth the receiver front-end should use can be set with one of the following both TAG items as shown in figure 6.37. These TAG items are not mandatory because it cannot be assumed that the receiving RSCI protocol parser unit is able to change the IF filter bandwidth of the HF front-end.

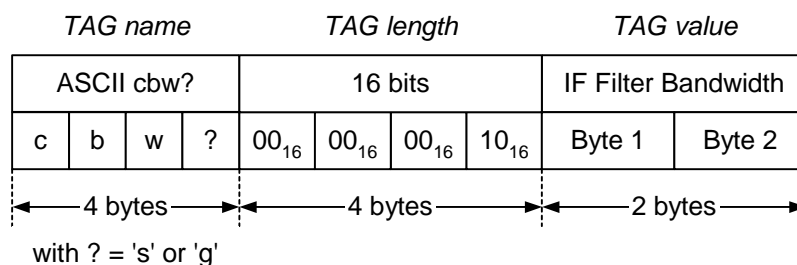

**Figure 6.37: Set IF filter bandwidth**

**IF filter bandwidth:** the format is  $(\text{Byte1} + \text{Byte2} / 256) = (\text{Byte1}.\text{Byte2})$  in [kHz] with:

- Byte1 is an 8-bit signed integer value; and
- Byte2 is an 8-bit unsigned integer value.

NOTE: This is the same as to put Byte1 and Byte2 into a signed 16-bit integer value (Byte1 is the higher part) and to divide this value by 256.

The TAG items "cbws" and "cbwg" both specify the desired IF filter bandwidth but differ in the way the value is interpreted:

- **TAG item "cbws":** from its available range of filter bandwidths, the receiver should choose the highest possible bandwidth which is smaller or equal than the requested bandwidth. In case that the lowest available bandwidth is greater than the requested value, the receiver should choose this value.

- **TAG item "cbwg"**: from its available range of filter bandwidths, the receiver should choose the lowest possible bandwidth which is greater or equal than the requested bandwidth. In case that the highest available bandwidth is smaller than the requested value, the receiver should choose this value.

### 6.5.1.5 Select service (cser)

The service identifier (short Id) of the service to be selected at the GUI is given by the following TAG item as shown in figure 6.38. This selection is important because the audio status (see clauses 6.4.3.3, 6.4.3.7 and 6.4.3.8) refers always to the selected service (see clause 6.4.3.5). Therefore this TAG item is mandatory for all RX\_CTRL profiles.

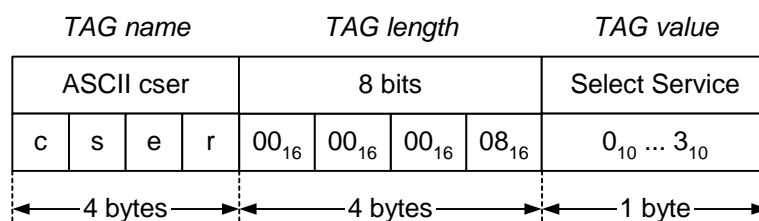

**Figure 6.38: Select service**

**Select service:** 8-bit signed integer value specifying the short Id (0 to 3) of the service to be selected.

## 6.5.2 TAG items for signal recording

The following TAG items are to switch on and off signal recording options of the receiver unit remotely.

### 6.5.2.1 Start/stop recording (crec)

Using the TAG item "crec" as shown in figure 6.39 start/stop commands can be sent to the receiver to switch remotely on or off recordings of the received signal or of a specific RX\_STAT profile.

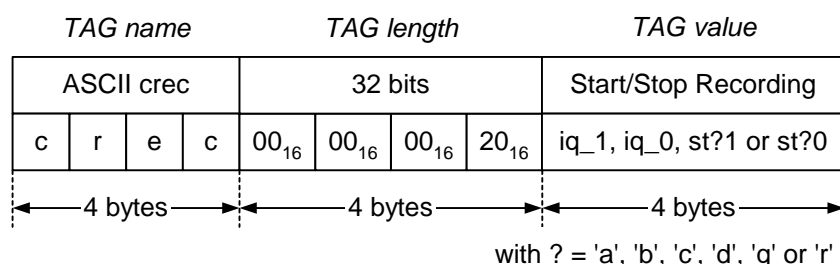

**Figure 6.39: Start or Stop recording**

The information on the recording type to be started or stopped is given as four ASCII characters:

iq_1	start recording of the input signal as IQ-file
iq_0	stop recording of the input signal as IQ-file
sta1	start recording of RX_STAT profile A output into a file
sta0	stop recording of RX_STAT profile A output
stb1	start recording of RX_STAT profile B output into a file
stb0	stop recording of RX_STAT profile B output
stc1	start recording of RX_STAT profile C output into a file
stc0	stop recording of RX_STAT profile C output
std1	start recording of RX_STAT profile D output into a file
std0	stop recording of RX_STAT profile D output
stq1	start recording of RX_STAT profile Q output into a file
stq0	stop recording of RX_STAT profile Q output
str1	start recording of RX_STAT profile R output into a file

str0 stop recording of RX\_STAT profile R output

The name of the recorded files shall be generated automatically matching the following format string:

XXXXXXXXXXXXXXXXXX\_YYYY-MM-DD\_HH-MM-SS\_FFFFFFFF.EXT

XXXX...XXXX ASCII text as transmitted in TAG item "rinf" (see clause 6.4.3.1)  
 YYYY-MM-DD year, month and day in UTC time at the moment the recording starts  
 HH-MM-SS hours, minutes and second in UTC time at the moment the recording starts  
 FFFFFFFF reception frequency in [Hz]  
 EXT file name extension as defined below

For IQ-file recording the file name extension indicates the sample rate:

.iq12 stands for a sample rate of 12 kHz  
 .iq24 stands for a sample rate of 24 kHz  
 .iq48 stands for a sample rate of 48 kHz  
 .iq192 stands for a sample rate of 192 kHz

The IQ-file comprises only the plain IQ-samples without any header information. The format of the IQ-samples is a 16-bit signed integer value for the I- or Q-sample, whereby the I-sample comes first with little endian byte order and LSB first.

For the status output recording the file name extension indicates the recorded RX\_STAT profile:

.rsX stands for a recording of RX\_STAT profile X, e.g. .rsA for profile A.

Recording into file shall be done via the file layer described in TS 102 821 [2]. No PFT layer is used.

The receiver should generate a new file as soon as the reception frequency is changed.

If the receiver has not implemented the RX\_STAT profile desired for recording, it should record the closest profile. The most close profile is the next smaller one providing most of the information of the desired profile or better the next bigger one comprising completely the information of the desired profile. In this context the ascending order of the RX\_STAT profiles is B → C → A → D. Profile Q can be placed before profile B or between profiles B and C depending on the TAG items the user is interested in. The TAG items of profile R are only covered by profiles A and D.

### 6.5.3 TAG items for RSCI output control

The following TAG items are used to control the RSCI output of the receiver. If a receiver supports multiple simultaneous RSCI outputs, then these TAG items affect only the RX\_STAT stream associated with the RX\_CTRL input on which the control TAG item is received.

#### 6.5.3.1 Selection of RX\_STAT profile (cpro)

The RX\_STAT profile output by the receiver can be controlled using this TAG item shown in figure 6.40. Upon reception of this TAG item, the receiver shall immediately start sending the requested RX\_STAT profile. In the event that the receiver does not support the requested profile, it shall continue to output the current profile.

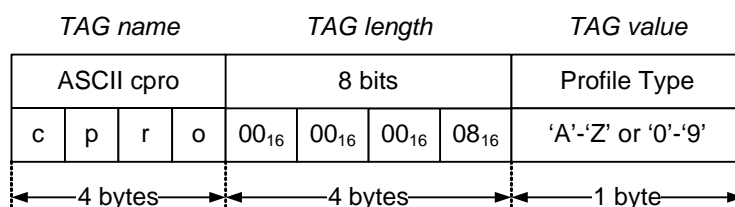

Figure 6.40: Control RX\_STAT profile

**Profile type:** ASCII alphabetic character "A", "B", "C", etc.: indicates the requested standard RX\_STAT profile.

ASCII character "1"-"9" indicates a requested user-defined profile.

ASCII character "0" indicates that no RSCI data should be transmitted.

To allow future expansions of this TAG item without backward incompatibility problems and without the need for a new TAG item doing nearly the same, the TAG length is not restricted to one byte. If the indicated length is greater than eight bits, then the first eight bits shall be interpreted as described above and the remaining bits ignored.

## 6.6 Revision history

Table 6.3 contains the history of the TAG item changes of the RSCI protocol for each new revision.

**Table 6.3: Revision history**

Major revision	Minor revision	Date	Changes from previous to new revision
0003 <sub>16</sub>	0000 <sub>16</sub>	2004-03-01	Initial public release.
0003 <sub>16</sub>	0001 <sub>16</sub>	2005-05-24	Timing and RSCI to MDI conversion added.
0003 <sub>16</sub>	0002 <sub>16</sub>	2008-12-05	Position calculation of TAG item "rgps" corrected, TAG items "rnic", "rnip" and "rpro" added, notes added and sizes corrected for TAG items "rpil" and "str?". Addition of sub-sampling, new TAG items including statistics, and new profile G.
0004 <sub>16</sub>	0000 <sub>16</sub>	2010-03-01	TAG item "rsnr" added, TAG items "fac_", "rdmo", "rspd", "rpir", "cdmo" and "crec" modified for robustness mode E, TAG items "rafs" and "reas" modified for full reporting of CELP and HVXC frames and robustness mode E.

Changes to the protocol which will allow existing decoders to still function will be represented by an increment of the minor version number only. Any new features added by the change will obviously not need to be supported by older modulators. Existing TAG items will not be altered except for the definition of bits previously declared as "rfu". New TAG items may be added.

Changes to the protocol which will render previous implementations unable to correctly process the new format will be represented by an increment of the major version number. Older implementations should not attempt to decode such TAG packets. Changes may include modification to or removal of existing TAG item definitions.

---

## 7 Test and measurement

A test and measurement transmission:

- As a **stand-alone** data service is signalled by the application identifier (see FAC service parameters in ES 201 980 [1], clause 6.3.4) with a value of 31<sub>10</sub> "skip indicator" (former "test and measurement" as stated in TS 101 968 [4], clause 4.2: the skip indicator is to allow for engineering test transmissions to be ignored by standard receivers). Additionally the type of test and measurement transmission is indicated in SDC application information data entity - type 5 as stated below.
- As programme associated data (the data stream is associated with an audio stream/service) is signalled **only** in SDC application information data entity - type 5 as stated below.

One type of test transmission is the transmission of a Pseudo Random Bit Sequence (PRBS). This provides the possibility to measure Bit Error Rates (BER) by comparing the received sequence with the locally generated error-free one.

The PRBS can be used in two ways:

- Synchronous PRBS: is resetted to start state (all memory taps in delay line are set to 1<sub>2</sub>) at the start of each super frame.



- Asynchronous PRBS: is a free running PRBS, which can start with any start value (except  $0_2$  for all memory taps in delay line).

The SDC application information data entity - type 5 (see ES 201 980 [1], clause 6.4.3.6 and TS 101 968 [4], clause 4.3) of a test and measurement transmission containing a PRBS data stream will be of the following format:

- Short Id                      2 bits
- Stream Id                    2 bits
- Packet Mode Indicator    1 bit             $0_{16}$
- rfa                            3 bits            $0_{16}$
- Enhancement Flag        1 bit             $0_{16}$
- Application Domain        3 bits            $0_{16}$
- Application Id              16 bits          $8\ 001_{16}$
- Application Data          40 bits         (see below)

**Short Id:** this field indicates the short Id for the service concerned.

**Stream Id:** this field indicates the stream Id of the stream, which carries the PRBS data concerned.

**Packet mode indicator:** this field indicates with value  $0_{16}$  that the service is carried in synchronous stream mode.

**rfa:** these three bits are reserved for future additions and shall be set to zero until they are defined.

**Enhancement flag:** this field indicates with value  $0_{16}$  that no enhancement data is available in another channel.

**Application domain:** this field indicates with value  $0_{16}$  that the source of the data application is the application domain "DRM" (see TS 101 968 [4], clause 4.3.1).

**Application Id:** this field indicates with value  $8\ 001_{16}$  that the data application is a "DRM specified proprietary data application" (see TS 101 968 [4], clause 4.3.2.1).

The application data field is filled as required by the corresponding application specification and in the actual case for a test and measurement transmission containing a PRBS data stream as follows:

- Synchronous Flag        1 bit             $0_{16}$  or  $1_{16}$
- rfa                            7 bits            $00_{16}$
- Generator Polynomial    32 bits          $00000000_{16} \dots \text{FFFFFFFF}_{16}$

**Synchronous flag:** this field indicates whether the indicated stream holds a synchronous ( $0_{16}$ ) or asynchronous ( $1_{16}$ ) PRBS.

**rfa:** these seven bits are reserved for future additions and shall be set to zero until they are defined.

**Generator polynomial:** this bit field indicates the generator polynomial - length of the shift register (tap delay line) with its feedbacks - to generate the PRBS.

The generator polynomial  $G_a(x) = x^a + \dots + x^z + 1$  is signalled by the bits number  $a$  down to  $z$  set to  $1_2$  for the feedbacks  $x^a \dots x^z$ , the remaining bits are set to  $0_2$ . In this context the LSB of the fourth byte is bit number one tantamount to feedback  $x^1$  (if present). The first feedback at  $1 = x^0$  is not signalled because it is present for all PRBS. The most significant 1-bit (bit number  $a$  at feedback  $x^a$ ) gives the needed length of the shift register (tap delay line) up to the maximum register length of 32.

For test and measurement transmissions the following sequence is used: This PRBS is generated by a shift register (tap delay line) of length 23 connected as shown in figure 7.1 resulting in the generator polynomial  $G_{23}(x) = x^{23} + x^{18} + 1$ . The register contents are initially all set to 1<sub>2</sub> (for a synchronous PRBS at the start of each super frame, for an asynchronous PRBS only at the first time) such that the sequence begins: 00000000<sub>2</sub> 00000000<sub>2</sub> 00111110<sub>2</sub> 00000000<sub>2</sub> 00001111<sub>2</sub> 11111100<sub>2</sub> 00000011<sub>2</sub> 11100000<sub>2</sub> 11111000<sub>2</sub> 1111<sub>2</sub> ... Successive groups of eight bits are assembled into bytes, with the first bit becoming the MSb of the byte.

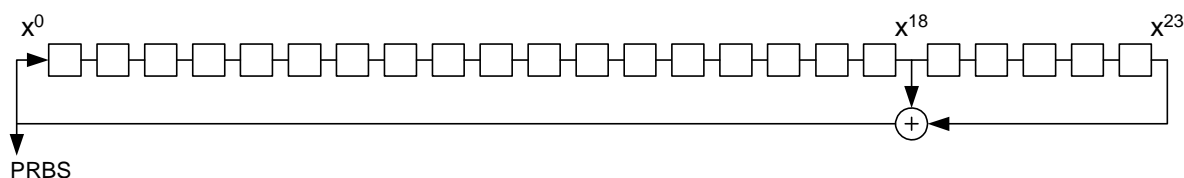

**Figure 7.1: Shift register for PRBS  $G_{23}(x)$  generation**

**EXAMPLE:** In case of a synchronous PRBS with generator polynomial  $G_{23}(x) = x^{23} + x^{18} + 1$  the application data field is filled with the following values:

Synchronous Flag	1 bit	0 <sub>16</sub>
rfa	7 bits	00 <sub>16</sub>
Generator Polynomial	32 bits	420 000 <sub>16</sub> = 1000010_00000000_00000000 <sub>2</sub>

In general every PRBS (up to a register length of 32) can be used because the generator polynomial is announced to the receiver in SDC application information data entity - type 5. So the receiver is able to adapt to the actual used sequence.

As soon as one data service or the programme associated data of an audio service is identified to contain PRBS data, a RX\_STAT profile A, B, C or D compliant receiver has to start to evaluate the BER of the referred data stream and output the BER on the according "rbp?" TAG item. If this not possible for any user-defined PRBS, so at least for the special case of test and measurement transmissions using PRBS  $G_{23}(x)$  the BER evaluation shall be done.

---

## History

<b>Document history</b>		
V1.1.1	January 2005	Publication
V1.2.1	November 2005	Publication
V1.3.1	April 2009	Publication
V3.1.1	December 2010	Publication