

ETSI TS 102 321 V1.1.1 (2004-05)

Technical Specification

Electromagnetic compatibility and Radio spectrum Matters (ERM); Normalized Site Attenuation (NSA) and validation of a fully lined anechoic chamber up to 40 GHz



Reference

DTS/ERM-TG33-063

Keywords

measurement uncertainty, mobile, radio, testing

ETSI

650 Route des Lucioles
F-06921 Sophia Antipolis Cedex - FRANCE

Tel.: +33 4 92 94 42 00 Fax: +33 4 93 65 47 16

Siret N° 348 623 562 00017 - NAF 742 C
Association à but non lucratif enregistrée à la
Sous-Préfecture de Grasse (06) N° 7803/88

Important notice

Individual copies of the present document can be downloaded from:

<http://www.etsi.org>

The present document may be made available in more than one electronic version or in print. In any case of existing or perceived difference in contents between such versions, the reference version is the Portable Document Format (PDF). In case of dispute, the reference shall be the printing on ETSI printers of the PDF version kept on a specific network drive within ETSI Secretariat.

Users of the present document should be aware that the document may be subject to revision or change of status. Information on the current status of this and other ETSI documents is available at

<http://portal.etsi.org/tb/status/status.asp>

If you find errors in the present document, send your comment to:

editor@etsi.org

Copyright Notification

No part may be reproduced except as authorized by written permission.
The copyright and the foregoing restriction extend to reproduction in all media.

© European Telecommunications Standards Institute 2004.
All rights reserved.

DECTTM, **PLUGTESTS**TM and **UMTS**TM are Trade Marks of ETSI registered for the benefit of its Members.
TIPHONTM and the **TIPHON logo** are Trade Marks currently being registered by ETSI for the benefit of its Members.
3GPPTM is a Trade Mark of ETSI registered for the benefit of its Members and of the 3GPP Organizational Partners.

Contents

Intellectual Property Rights	5
Foreword.....	5
1 Scope	6
2 References	6
3 Definitions, symbols and abbreviations	7
3.1 Definitions	7
3.2 Symbols.....	8
3.3 Abbreviations	10
4 Introduction	10
5 Review of verification procedures for an anechoic chamber	11
5.1 Introduction	11
5.2 Normalized Site Attenuation (NSA).....	12
5.3 NSA in an ideal anechoic chamber.....	12
5.4 Mutual coupling	12
5.5 Overview of the verification procedure.....	13
5.5.1 Apparatus required.....	13
5.5.2 Site preparation	15
5.5.3 Measurement configuration	15
5.5.4 What to record	17
6 Verification procedure.....	18
6.1 Introduction	18
6.2 Procedure 1: 30 MHz to 1 000 MHz	18
6.2.1 Direct attenuation.....	18
6.2.2 Radiated attenuation: Horizontal polarization	19
6.2.3 Radiated attenuation: Vertical polarization.....	22
6.3 Alternative Procedure 1: 30 MHz to 1 000 MHz	23
6.4 Procedure 2: 1 GHz to 18 GHz.....	23
6.4.1 Direct attenuation.....	23
6.4.2 Radiated attenuation: Horizontal polarization	24
6.4.3 Radiated attenuation: Vertical polarization.....	25
6.5 Procedure 3: 18 GHz to 26 GHz.....	28
6.5.1 Direct attenuation.....	28
6.5.2 Radiated attenuation: Horizontal polarization	28
6.5.3 Radiated attenuation: Vertical polarization.....	29
6.6 Procedure 4: 26 GHz to 40 GHz.....	31
6.6.1 Direct attenuation.....	31
6.6.2 Radiated attenuation: Horizontal polarization	31
6.6.3 Radiated attenuation: Vertical polarization.....	32
7 Processing the results of the verification procedure	34
7.1 Introduction	34
7.2 Procedure 1: 30 MHz to 1 000 MHz	34
7.2.1 Antenna factors	34
7.2.2 Mutual coupling and mismatch loss correction factors.....	35
7.2.3 Completion of the results sheet.....	36
7.3 Procedure 2: 1 GHz to 18 GHz.....	37
7.3.1 Antenna factors	37
7.3.2 Completion of the results sheet.....	37
7.4 Procedure 3: 18 GHz to 26 GHz.....	39
7.4.1 Antenna factors	39
7.4.2 Completion of the results sheet.....	39
7.5 Procedure 4: 26 GHz to 40 GHz.....	40
7.5.1 Antenna factors	40

7.5.2	Completion of the results sheet.....	40
8	Report format	42
9	Evaluation of uncertainty contributions specific to an anechoic chamber	42
9.1	Effects of the metal shielding	42
9.1.1	Resonances	43
9.1.2	Imaging of antennas.....	43
9.2	Effects of the radio absorbing materials	44
9.2.1	Introduction.....	44
9.2.2	Pyramidal absorbers.....	44
9.2.3	Wedge absorbers.....	44
9.2.4	Ferrite tiles	45
9.2.5	Ferrite grids.....	45
9.2.6	Urethane/ferrite hybrids	45
9.2.7	Floor absorbers	45
9.2.8	Reflection in an anechoic chamber	46
9.2.9	Mutual coupling due to imaging in the absorbing material	47
9.3	Other effects	47
9.3.1	Extraneous reflections.....	47
9.3.2	Mutual coupling between antennas (or antenna and EUT).....	47
9.3.3	Turntable and antenna mounting fixtures	47
9.3.4	Antenna cabling	48
9.3.5	Positioning of the antennas	48
10	Calculation of measurement uncertainty (Procedure 1)	49
10.1	Uncertainty contribution, direct attenuation measurement.....	49
10.2	Uncertainty contribution, NSA measurement.....	50
10.3	Expanded uncertainty of the verification procedure.....	51
11	Calculation of measurement uncertainty (Procedure 2)	52
11.1	Uncertainty contribution, direct attenuation measurement.....	52
11.2	Uncertainty contribution, NSA measurement.....	53
11.3	Expanded uncertainty of the verification procedure.....	54
12	Calculation of measurement uncertainty (Procedure 3)	55
12.1	Uncertainty contribution, direct attenuation measurement.....	55
12.2	Uncertainty contribution, NSA measurement.....	56
12.3	Expanded uncertainty of the verification procedure.....	57
13	Calculation of measurement uncertainty (Procedure 4)	57
13.1	Uncertainty contribution, direct attenuation measurement.....	57
13.2	Uncertainty contribution, NSA measurement.....	58
13.3	Expanded uncertainty of the verification procedure.....	59
14	Summary	59
	Annex A (informative): Bibliography.....	60
	History	61

Intellectual Property Rights

IPRs essential or potentially essential to the present document may have been declared to ETSI. The information pertaining to these essential IPRs, if any, is publicly available for **ETSI members and non-members**, and can be found in ETSI SR 000 314: "*Intellectual Property Rights (IPRs); Essential, or potentially Essential, IPRs notified to ETSI in respect of ETSI standards*", which is available from the ETSI Secretariat. Latest updates are available on the ETSI Web server (<http://webapp.etsi.org/IPR/home.asp>).

Pursuant to the ETSI IPR Policy, no investigation, including IPR searches, has been carried out by ETSI. No guarantee can be given as to the existence of other IPRs not referenced in ETSI SR 000 314 (or the updates on the ETSI Web server) which are, or may be, or may become, essential to the present document.

Foreword

This Technical Specification (TS) has been produced by ETSI Technical Committee Electromagnetic compatibility and Radio spectrum Matters (ERM).

1 Scope

The present document details verification procedure for anechoic chambers used as test sites for radiated Radio Frequency (RF) testing on radio equipment and additionally provides the methods for evaluating the associated measurement uncertainties.

The present document has been produced in the absence of standardized validation procedures for fully lined anechoic chambers over the current test frequency range of 30 MHz to 40 GHz.

The present document provides validation methods that can be used together with all applicable standards and (E)TRs, supports TR 100 027 [10] and may be used in association with TR 100 028 [9].

2 References

The following documents contain provisions which, through reference in this text, constitute provisions of the present document.

- References are either specific (identified by date of publication and/or edition number or version number) or non-specific.
- For a specific reference, subsequent revisions do not apply.
- For a non-specific reference, the latest version applies.

Referenced documents which are not found to be publicly available in the expected location might be found at <http://docbox.etsi.org/Reference>.

- [1] ANSI C63.5 (1988): "Electromagnetic Compatibility-Radiated Emission Measurements in Electromagnetic Interference (EMI) Control - Calibration of Antennas".
- [2] "Antenna Theory: Analysis and Design", 2nd Edition, Constantine A.Balanis (1996).
- [3] "Calculation of site attenuation from antenna factors", A. A. Smith Jr, RF German and J B Pate. IEEE transactions EMC. Vol. EMC 24 pp 301-316, Aug 1982.
- [4] CISPR 16-1: "Specification for radio disturbance and immunity measuring apparatus and methods - Part 1: Radio disturbance and immunity measuring apparatus".
- [5] CENELEC EN 50147-2 (1996): "Anechoic Chambers - Part 2: Alternative test site suitability with respect to site attenuation".
- [6] ETSI TR 102 273-1-1: "ElectroMagnetic Compatibility and Radio Spectrum Matters (ERM); Improvement on Radiated Methods of Measurement (using test site) and evaluation of the corresponding measurement uncertainties Part 1: Uncertainties in the measurement of mobile radio equipment characteristics; Sub-part 1: Introduction".
- [7] ETSI TR 102 273-1-2: "ElectroMagnetic Compatibility and Radio Spectrum Matters (ERM); Improvement on Radiated Methods of Measurement (using test site) and evaluation of the corresponding measurement uncertainties; Part 1: Uncertainties in the measurement of mobile radio equipment characteristics; Sub-part 2: Examples and annexes".
- [8] The new IEEE standard dictionary of electrical and electronic terms Fifth edition, IEEE Piscataway, NJ USA (1993).
- [9] ETSI TR 100 028 (Parts 1 and 2): "Electromagnetic compatibility and Radio spectrum Matters (ERM); Uncertainties in the measurement of mobile radio equipment characteristics".
- [10] ETSI TR 100 027 (V1.2.1): "ElectroMagnetic Compatibility and Radio Spectrum Matters (ERM); Methods of measurement for private mobile radio equipment".

3 Definitions, symbols and abbreviations

3.1 Definitions

For the purposes of the present document, the following terms and definitions apply:

antenna: that part of a transmitting or receiving system that is designed to radiate or to receive electromagnetic waves

antenna factor: quantity relating to the strength of the field in which the antenna is immersed to the output voltage across the load connected to the antenna

NOTE: When properly applied to the meter reading of the measuring instrument, yields the electric field strength in V/m or the magnetic field strength in A/m.

antenna gain: ratio of the maximum radiation intensity from an (assumed lossless) antenna to the radiation intensity that would be obtained if the same power were radiated isotropically by a similarly lossless antenna

combined standard uncertainty: combined standard uncertainty is calculated by combining appropriately the standard uncertainties for each of the individual contributions identified in the measurement considered or in the part of it, which has been considered

confidence level: probability of the accumulated error of a measurement being within the stated range of uncertainty of measurement

correction factor: numerical factor by which the uncorrected result of a measurement is multiplied to compensate for an assumed systematic error

directivity: ratio of the maximum radiation intensity in a given direction from the antenna to the radiation intensity averaged over all directions (i.e. directivity = antenna gain + losses)

expanded uncertainty: expanded uncertainty is the uncertainty value corresponding to a specific confidence level different from that inherent to the calculations made in order to find the combined standard uncertainty

free field: field (wave or potential) which has a constant ratio between the electric and magnetic field intensities

free space: region free of obstructions and characterized by the constitutive parameters of a vacuum

isotropic radiator: hypothetical, lossless antenna having equal radiation intensity in all directions

measurand: quantity subject to measurement

polarization: for an electromagnetic wave, the figure traced as a function of time by the extremity of the electric vector at a fixed point in space

random uncertainty: component of the uncertainty of measurement which, in the course of a number of measurements of the same measurand, varies in an unpredictable way

NOTE: (to be considered as a component for the calculation of the combined uncertainty when the effects it corresponds to have not been taken into consideration otherwise).

shielded enclosure: structure that protects its interior from the effects of an exterior electric or magnetic field or conversely, protects the surrounding environment from the effect of an interior electric or magnetic field

standard uncertainty: expression characterizing, for each individual uncertainty component, the uncertainty for that component

NOTE: It is the standard deviation of the corresponding distribution.

systematic uncertainty: component of the uncertainty of measurement which, in the course of a number of measurements of the same measurand remains constant or varies in a predictable way

uncertainty (limits of uncertainty of a measuring instrument): extreme values of uncertainty permitted by specifications, regulations etc. for a given measuring instrument

NOTE: This term is also known as "tolerance".

3.2 Symbols

For the purposes of the present document, the following symbols apply:

β	$2\pi/\lambda$ (radians/m)
γ	incidence angle with ground plane ($^{\circ}$)
λ	wavelength (m)
ϕ_H	phase angle of reflection coefficient ($^{\circ}$)
η	$120\pi \Omega$ - the intrinsic impedance of free space
μ	permeability (H/m)
AF_R	Antenna Factor of the receive antenna (dB/m)
AF_T	Antenna Factor of the transmit antenna (dB/m)
AF_{TOT}	mutual coupling correction factor (dB)
c	calculated on the basis of given and measured data
C_{cross}	cross correlation coefficient
d	derived from a measuring equipment specification
$D(\theta, \phi)$	directivity of the source
d	distance between dipoles (m)
δ	skin depth (m)
d_1	an antenna or EUT aperture size (m)
d_2	an antenna or EUT aperture size (m)
d_{dir}	path length of the direct signal (m)
d_{refl}	path length of the reflected signal (m)
E	Electric field intensity (V/m)
E_{DH}^{max}	calculated maximum electric field strength in the receiving antenna height scan from a half wavelength dipole with 1 pW of radiated power (for horizontal polarization) ($\mu\text{V/m}$)
E_{DV}^{max}	calculated maximum electric field strength in the receiving antenna height scan from a half wavelength dipole with 1 pW of radiated power (for vertical polarization) ($\mu\text{V/m}$)
e_{ff}	antenna efficiency factor
ϕ	angle ($^{\circ}$)
Δf	bandwidth (Hz)
f	frequency (Hz)
$G(\theta, \phi)$	gain of the source (which is the source directivity multiplied by the antenna efficiency factor)
H	magnetic field intensity (A/m)
I_0	the (assumed constant) current (A)
I_m	the maximum current amplitude
k	$2\pi/\lambda$
k	a factor from Student's t distribution
k	Boltzmann's constant ($1,38 \times 10^{-23}$ Joules/ $^{\circ}$ Kelvin)
K	relative dielectric constant
l	the length of the infinitesimal dipole (m)
L	the overall length of the dipole (m)
l	the point on the dipole being considered (m)
m	measured
p	power level value
$Pe_{(n)}$	Probability of error n
$Pp_{(n)}$	Probability of position n
P_r	antenna noise power (W)

P_{rec}	Power received (W)
P_t	Power transmitted (W)
θ	angle (°)
ρ	reflection coefficient
r	the distance to the field point (m)
ρ_g	reflection coefficient of the generator part of a connection
ρ_l	reflection coefficient of the load part of the connection
R_s	equivalent surface resistance (Ω)
σ	conductivity (S/m)
σ	standard deviation
r	indicates rectangular distribution
T_A	antenna temperature (° Kelvin)
u	indicates U-distribution
U	the expanded uncertainty corresponding to a confidence level of x %: $U = k \times u_c$
u_c	the combined standard uncertainty
u_i	general type A standard uncertainty
u_{i01}	random uncertainty
u_j	general type B uncertainty
u_{j02}	reflectivity of absorbing material: substitution or measuring antenna to the test antenna
u_{j03}	reflectivity of absorbing material: transmitting antenna to the receiving antenna
u_{j06}	mutual coupling: substitution, measuring or test antenna to its image in the absorbing material
u_{j07}	mutual coupling: transmitting or receiving antenna to its image in the absorbing material
u_{j10}	mutual coupling: transmitting antenna to the receiving antenna
u_{j11}	mutual coupling: substitution or measuring antenna to the test antenna
u_{j12}	mutual coupling: interpolation of mutual coupling and mismatch loss correction factors
u_{j16}	range length
u_{j17}	correction: off boresight angle in the elevation plane
u_{j18}	correction: measurement distance
u_{j19}	cable factor
u_{j22}	position of the phase centre: measuring, substitution, receiving, transmitting or test antenna
u_{j23}	position of the phase centre: LPDA
u_{j34}	ambient effect
u_{j35}	mismatch: direct attenuation measurement
u_{j36}	mismatch: transmitting part
u_{j37}	mismatch: receiving part
u_{j38}	signal generator: absolute output level
u_{j39}	signal generator: output level stability
u_{j40}	insertion loss: attenuator
u_{j41}	insertion loss: cable
u_{j42}	insertion loss: adapter
u_{j43}	insertion loss: antenna balun
u_{j44}	antenna: antenna factor of the transmitting, receiving or measuring antenna
u_{j45}	antenna: gain of the test or substitution antenna
u_{j46}	antenna: tuning
u_{j47}	receiving device: absolute level
u_{j48}	receiving device: linearity
u_{j49}	receiving device: power measuring receiver
V_{direct}	received voltage for cables connected via an adapter (dB μ V/m)
V_{site}	received voltage for cables connected to the antennas (dB μ V/m)
W_0	radiated power density (W/m ²)

3.3 Abbreviations

For the purposes of the present document, the following abbreviations apply:

AF	Antenna Factor
LPDA	Log Periodic Dipole Antenna
m	measured
NSA	Normalized Site Attenuation
r	indicates rectangular distribution
RF	Radio Frequency
RSS	Root-Sum-of-the-Squares
u	indicates U-distribution
VSWR	Voltage Standing Wave Ratio

4 Introduction

An anechoic chamber is an enclosure whose internal walls, floor and ceiling are covered with radio absorbing material, normally of the pyramidal urethane foam type. It is normally shielded against the local radiated ambient. The chamber contains an antenna support at one end and a turntable at the other. A typical anechoic chamber is shown in figure 1 with indicative dipole antennas at both ends.

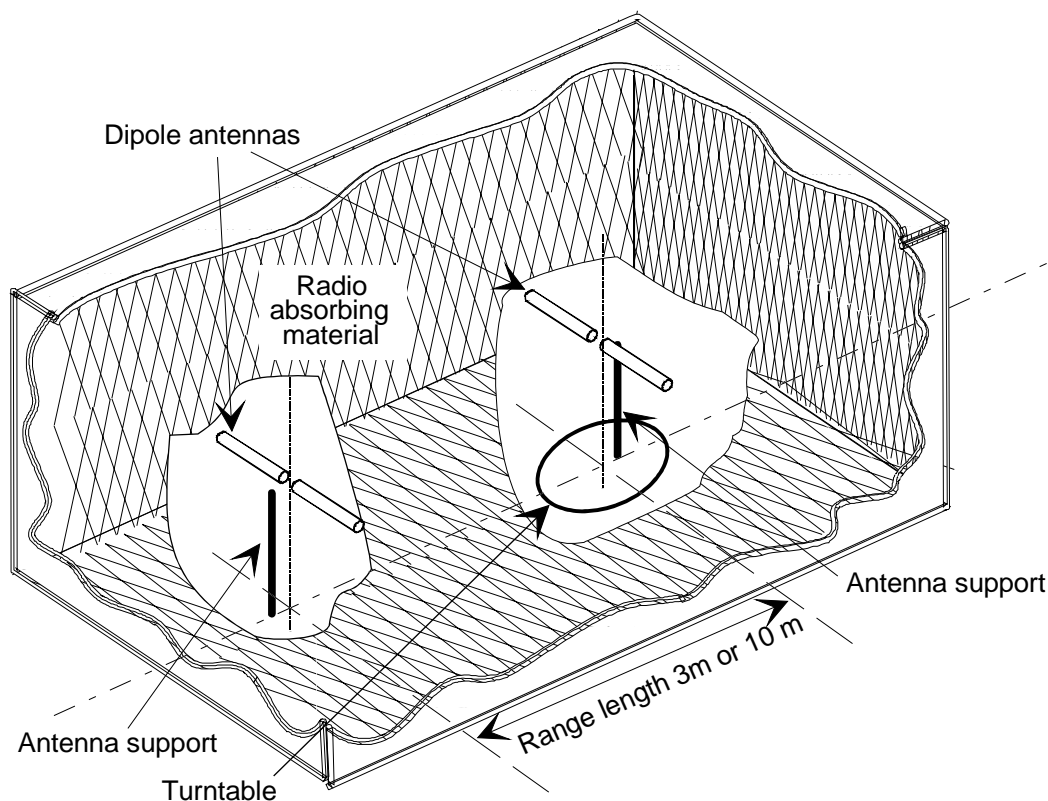

Figure 1: A typical fully lined anechoic chamber

The chamber shielding and radio absorbing material work together to provide a controlled environment for testing purposes. This type of test chamber attempts to simulate free space conditions. The shielding provides a test space, with reduced levels of interference from ambient signals and other outside effects, whilst the radio absorbing material minimizes unwanted reflections from the walls, floor and ceiling which could influence the measurements.

In practice whilst it is relatively easy for the shielding to provide high levels (80 dB to 140 dB) of ambient interference rejection (normally making ambient interference negligible), no design of radio absorbing material satisfies the requirement of complete absorption of all the incident power. For example it cannot be perfectly manufactured and installed and its return loss (a measure of its efficiency) varies with frequency, angle of incidence and in some cases, is influenced by high power levels of incident radio energy. To improve the return loss over a broader frequency range, ferrite tiles, ferrite grids and hybrids of urethane foam and ferrite tiles are used with varying degrees of success.

The anechoic chamber generally has several advantages over other test facilities. There is minimal ambient interference, minimal floor, ceiling and wall reflections and it is independent of the weather. It does however have some disadvantages which include limited measuring distance (due to available room size, cost, etc.) and limited lower frequency usage due to the size of the room and the pyramidal absorbers.

Both absolute and relative measurements can be performed in an anechoic chamber.

Where absolute measurements are to be carried out, or where the test facility is to be used for accredited measurements, the chamber shall be verified in accordance with the validation procedures given in the present document.

Verification involves comparison of the measured performance to that of an ideal theoretical chamber, with acceptability being decided on the basis of the maximum difference between the two.

5 Review of verification procedures for an anechoic chamber

5.1 Introduction

The verification procedure is a process carried out in an anechoic chamber to prove the suitability as a "free field" test sites.

For an anechoic chamber the verification procedure involves the transmission of a known signal level from one calibrated antenna and the measurement of the received signal level in a second calibrated antenna.

By comparison of the transmitted and received signal levels, an "insertion loss" can be deduced. After inclusion of any correction factors for the measurement, the figure of loss that results from the verification procedure is known as "site attenuation".

Site attenuation is defined [8] as "the ratio of the power input of a matched, balanced, lossless, tuned dipole radiator to that at the output of a similarly matched, balanced, lossless, tuned dipole receiving antenna for specified polarization, separation and heights above a flat reflecting surface. It is a measure of the transmission path loss between two antennas".

As the definition states "... above a flat reflecting surface", it is usual for the verification procedure to involve one antenna (the transmitting antenna) remaining fixed in height whilst a second antenna (the receiving antenna) is scanned through a specified height range looking for a peak in the received signal level.

The parameter of site attenuation originated for Open Area Test Sites (OATS), hence the reference to a reflective ground plane in the definition. The term is, however, also used in association with anechoic chambers. The measurement of site attenuation in such an anechoic chamber provides an equally good measure of the facility's quality as it does for an OATS. Without a "flat reflecting surface", an anechoic chamber has no ground reflection and hence a vertical height scan is unnecessary.

The determination of site attenuation involves two different measurements of received signal level. The first is with all the items of test equipment connected directly together via an adapter, whilst the second involves replacing the adapter with a pair of antennas. The difference in received levels (after allowance for any relevant correction factors which may be appropriate), for the same signal generator output level, is the site attenuation.

The verification procedure for an anechoic chamber is based on EN 50147-2 [5] which itself is based on that given in CISPR 16-1 [4] clauses 15.4 to 16.6.3. Both procedures call for the determination of Normalized Site Attenuation (NSA) which is equivalent to site attenuation after subtraction of the antenna factors and any mutual coupling effects.

NOTE: EN 50147-2 [5] and CISPR 16-1 [4] only detail verification procedures in the 30 MHz to 1 000 MHz frequency band.

It is particularly for the verification of Open Area Test Sites that NSA has historically found use. However, the same approach has also been adopted in the verification procedures that follow for an anechoic chamber.

5.2 Normalized Site Attenuation (NSA)

NSA is determined from the value of site attenuation by subtraction of the antenna factors and mutual coupling effects. The subtraction of the antenna factors makes NSA independent of antenna type.

NOTE: The uncertainty of the resulting value for NSA depends directly on the uncertainty with which the antenna factors are known.

Symbolically,

$$NSA = V_{\text{direct}} - V_{\text{site}} - AF_T - AF_R - AF_{TOT}$$

where:

V_{direct} = received voltage for cables connected via the "in-line" adapter;

V_{site} = received voltage for cables connected to the antennas;

AF_T = antenna factor of the transmit antenna;

AF_R = antenna factor of the receive antenna;

AF_{TOT} = mutual coupling correction factor.

The verification procedure compares the measured NSA (after relevant corrections) against the theoretical figure calculated for an ideal anechoic chamber. The difference between the two values at any specific frequency is a measure of the quality of the chamber at that frequency.

5.3 NSA in an ideal anechoic chamber

The theoretical ideal values for NSA in an ideal anechoic chamber have been calculated and included in tables 10, 11, 12 and 13 of clause 7. These values are used to assess the measured values to comply with the validation requirement of ± 4 dB.

5.4 Mutual coupling

Mutual coupling may exist between the antennas during the verification procedure. This may modify the results since it can change antenna input impedance/voltage standing wave ratio and gain/antenna factors of both antennas.

Figure 2 shows schematically mutual coupling as it occurs between antennas in a reflection-free environment.

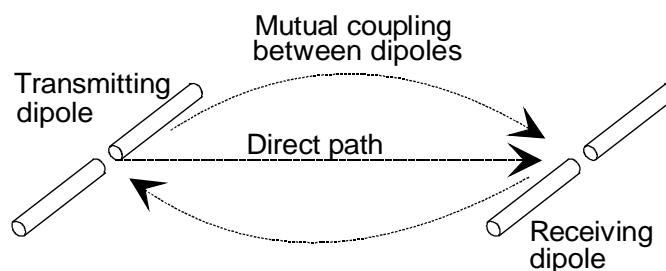

Figure 2: Direct path and mutual coupling

For accurate determination of NSA these additional effects needs to be taken into consideration and correction factors should be applied to the measured results to compensate.

In the verification procedures that follow, tables of correction factors are provided for mutual coupling between dipoles, where appropriate, for 3 m and 10 m range lengths.

Where alternative antennas are used for verification at higher frequencies mutual coupling is insignificant and therefore correction factors are not required.

5.5 Overview of the verification procedure

The first step in the verification procedure is the gathering of all the appropriate test equipment and preparation of the site.

The test equipment is then configured, and the verification procedure carried out.

On completion of the verification procedure, the results are to be processed. At each test frequency a value for the deviation of the chamber performance from the ideal is calculated and plotted (see figure 23) and the measurement uncertainties calculated.

The verification procedure recommends an antenna scheme in the 30 MHz to 1 000 MHz frequency band which uses tuned, half wavelength dipoles for all frequencies in the range 80 MHz to 1 000 MHz and shortened dipoles below 80 MHz.

NOTE: For cases in which this is not suitable, an alternative scheme using dipoles and bicones (possibly also LPDAs) is suggested. It should be noted that measurement uncertainty is likely to be degraded if the recommended dipole scheme is not used.

For the 1 GHz to 18 GHz band, broadband antennas (LPDAs) are recommended. For the 18 GHz to 26 GHz and 26 GHz to 40 GHz bands standard gain horns are recommended.

Throughout the frequency bands from 30 MHz to 40 GHz the procedure involves discrete frequencies only. For the frequency range 30 MHz to 1 000 MHz, the frequencies have been taken from CISPR 16-1 [4], annex G.

Figure 3 shows a typical verification testing arrangement of antennas (for the lower band) and test equipment.

5.5.1 Apparatus required

- attenuator pads, 10 dB;
- connecting cables;
- ferrite beads;
- receiving device (measuring receiver or spectrum analyser);
- signal generator;
- transmit antenna;
- receive antenna.

For frequencies from 30 MHz to 1 000 MHz:

- transmit antenna (half wavelength dipole as detailed in ANSI C63.5 [1] recommended);
- receive antenna (half wavelength dipole as detailed in ANSI C63.5 [1] recommended).

NOTE 1: Alternatively dipoles plus bicones or dipoles plus bicones and LPDAs may be used.

NOTE 2: The reference dipole antennas, incorporating matching/transforming baluns, for the procedure are available in the following bands: 20 MHz to 65 MHz, 65 MHz to 180 MHz, 180 MHz to 400 MHz, 400 MHz to 1 000 MHz. Constructional details are contained in ANSI C63.5 [1]. In the recommended antenna scheme for verification in this band, a shortened dipole is used at all frequencies from 30 MHz to 70 MHz inclusive.

For frequencies above 1 000 MHz:

- Transmit antenna (LPDA 1 GHz to 18 GHz);
- Receive antenna (LPDA 1 GHz to 18 GHz);
- Transmit antenna (standard gain horns 18 GHz to 40 GHz);
- Receive antenna (standard gain horns 18 GHz to 40 GHz).

The type and serial numbers of all items of test equipment shall be recorded in the results sheet relevant to the frequency band i.e. table 7 for the 30 MHz to 1 000 MHz band, table 8 for the 1 MHz to 18 GHz band, table 9 for the 18 GHz to 26 GHz band and table 10 for the 26 GHz to 40 GHz band.

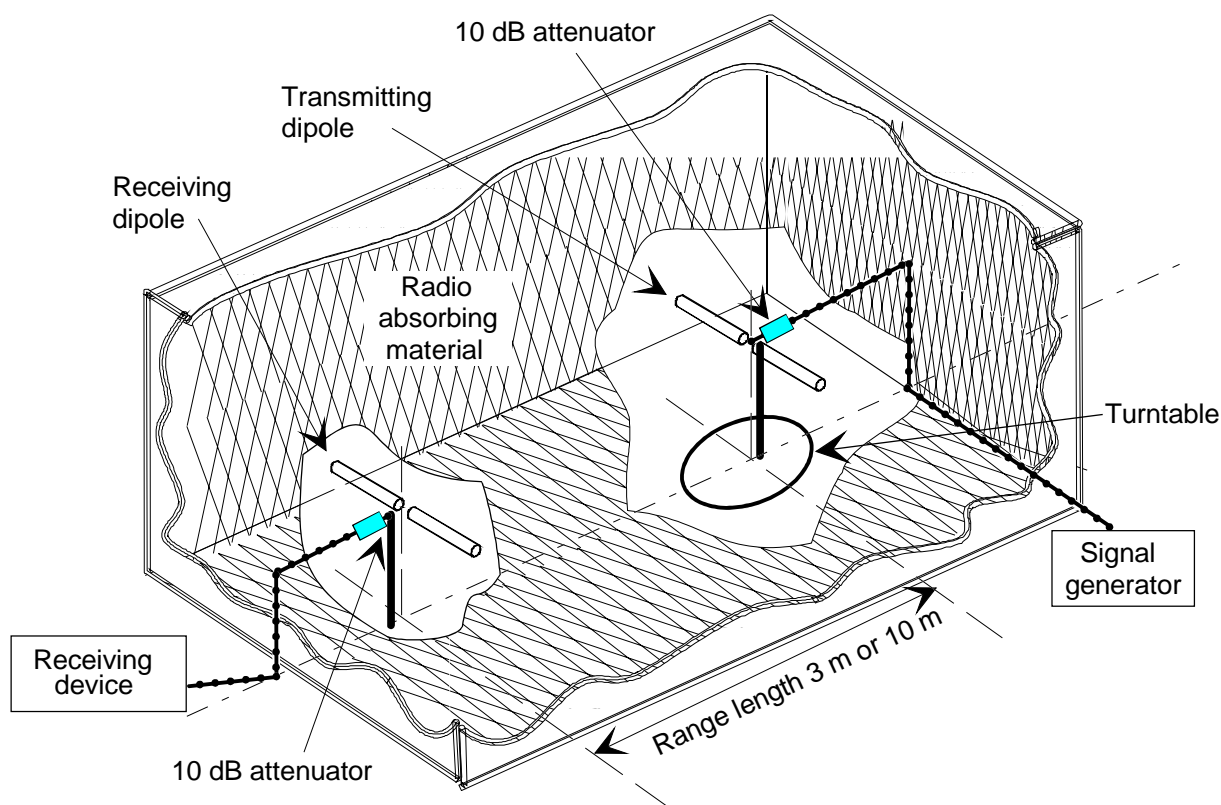

Figure 3: Site layout for the verification procedure using horizontally polarized dipoles in an anechoic chamber

5.5.2 Site preparation

Prior to the start of the verification procedure, system checks shall be made on the test equipment to be used. All items of test equipment where appropriate, shall be connected to power supplies, switched on and allowed adequate time to stabilize, as recommended by the manufacturers. Where the manufacturer does not give a stabilization period, 30 mins shall be allowed.

The cables for both ends of the chamber shall be routed behind and away from the antennas, parallel to the side walls and floor of the chamber, towards the back walls for a minimum of 2 m (unless the back wall is reached). They shall then be allowed to drop vertically towards the floor, preferably behind the anechoic panels, and routed out through the screen (normally via a breakout panel) to the test equipment.

These cables shall be dressed with ferrite beads, spaced 0,15 m apart for their entire lengths within the screen of the chamber. The cables, their routing and dressing shall be the same as for the normal operation of the chamber.

Calibration data for all items of test equipment shall be available and valid. For all non-ANSI dipoles, the data shall include VSWR and antenna factor (or gain) against frequency. The calibration data for all cables and attenuators shall include insertion loss and VSWR throughout the entire frequency range of the tests. Where any correction factors/tables are required, these shall be immediately available.

5.5.3 Measurement configuration

For the frequency band 30 MHz to 1 000 MHz, both antennas shall be tuned half-wavelength dipoles (constructed as detailed in ANSI C63.5 [1]) aligned for the same polarization.

NOTE 1: Due to size constraints a shortened dipole is used over part of this frequency band. For uniformity of verification procedure across Open Area Test Sites and an anechoic chamber, a shortened dipole is used from 30 MHz to 70 MHz inclusive. At all these frequencies the 80 MHz arm length (0,889 m) is used attached to the 20 MHz to 65 MHz balun for all test frequencies in the 30 MHz to 60 MHz band and to the 65 MHz to 180 MHz balun for 70 MHz. Tuned half wavelength dipoles, attached to their matching baluns are used for all frequencies in the band 80 MHz to 1 000 MHz inclusive. Table 1 details dipole arm lengths (as measured from the centre of the balun block) and balun type against frequency.

Table 1: Dipole arm length and balun type against frequency

Frequency (MHz)	Dipole arm length (m)	Balun type	Frequency (MHz)	Dipole arm length (m)	Balun type
30	0,889	20 MHz to 65 MHz	160	0,440	65 MHz to 180 MHz
35	0,889		180	0,391	
40	0,889		200	0,352	
45	0,889		250	0,283	180 MHz to 400 MHz
50	0,889		300	0,235	
60	0,889		400	0,175	
70	0,889	65 MHz to 180 MHz	500	0,143	400 MHz to 1 000 MHz
80	0,889		600	0,117	
90	0,791		700	0,102	
100	0,714		800	0,089	
120	0,593		900	0,079	
140	0,508		1 000	0,076	

For the 30 MHz to 1 000 MHz band, the restriction that no part of an antenna shall come within 1 metre of any part of the absorbing panels puts a limit on the number of combinations of transmitting antenna positions and polarizations for this procedure. For each polarization, five positions within the chamber are verified. These are shown in figures 4 and 5. Optionally, four further positions, shown in outline in these figures and figure 9 (where the H and V suffices refer to horizontal and vertical polarizations respectively) may be tested for each polarization if required. Correction factors (where appropriate) and NSA data are supplied for all positions.

The same antenna positions/polarization scheme is used in the 1 GHz to 40 GHz bands for which both antennas shall be aligned for the same polarization.

NOTE 2: When the transmitting antenna is used at positions other than on the central axis of the chamber, the transmitting and receiving antennas should be aligned for maximum signal i.e. they should point directly towards each other.

For both frequency bands, the measured NSA is determined for all positions/polarizations.

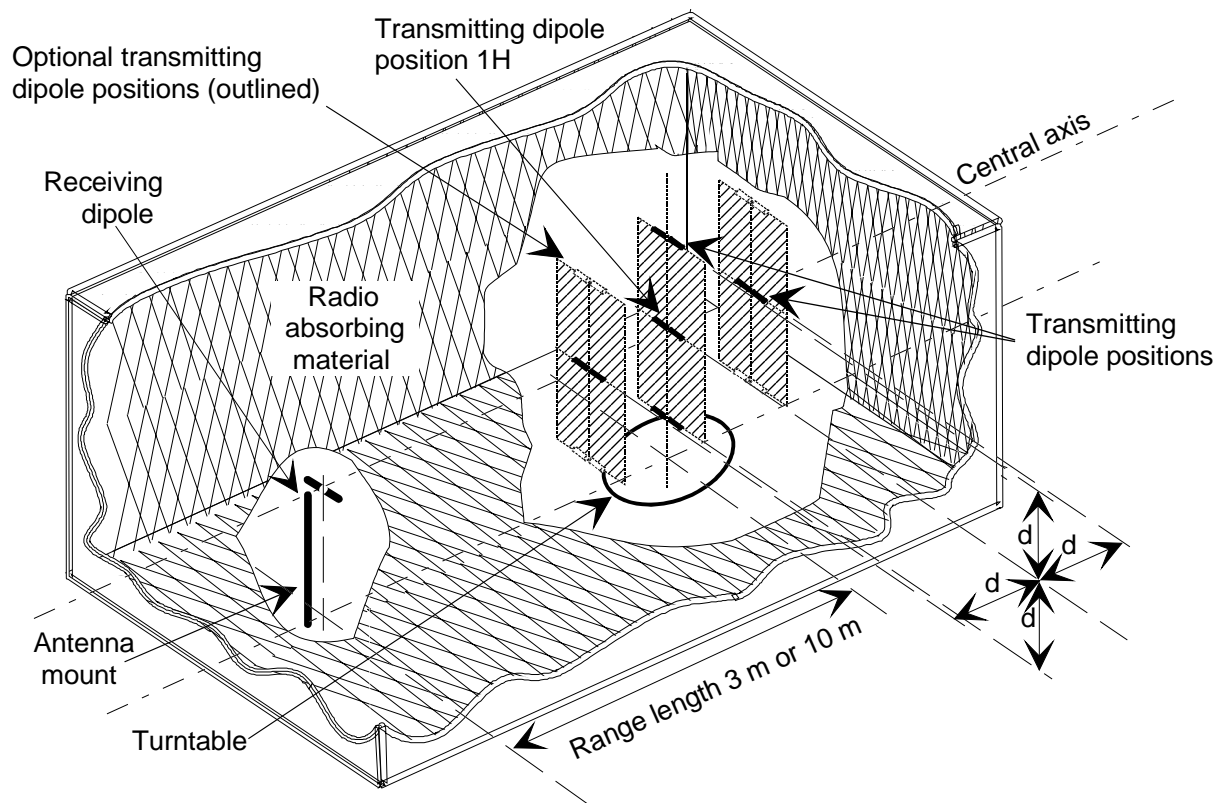

Figure 4: Antenna arrangements for horizontal polarization

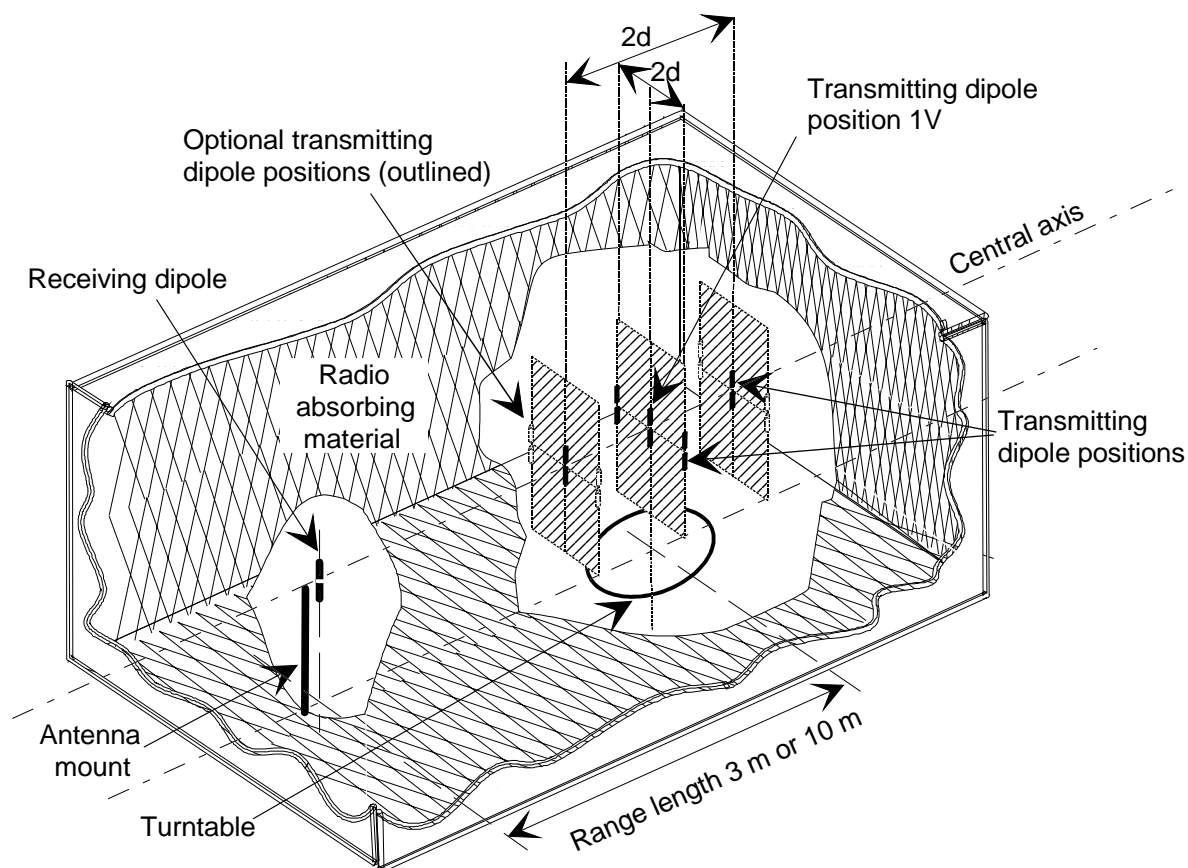

Figure 5: Antenna arrangements for vertical polarization

5.5.4 What to record

During the course of the procedure the chamber ambient temperature and relative humidity shall be recorded.

Also during the course of the procedure, the output level of the signal generator, the received level, the tuned frequency and polarization of the antennas shall be recorded along with ALL equipment used i.e. signal generator, receiver, cables, connectors, etc. An example of the results sheet is shown in table 2. A set of 10 results sheets (optionally 18), one corresponding to each position/polarization of the transmitting antenna, shall be completed for each frequency band.

NOTE: The results sheets for 1,0 GHz to 40 GHz verification are identical to table 2 except for the omission of the column for mutual coupling correction factor AF_{TOT} . Where LPDAs and standard gain horns are used, no corrections for mutual coupling are necessary.

Table 2: Example of an anechoic chamber verification results sheet

Anechoic chamber verification procedure results sheet 30 MHz to 1 000 MHz								
Range length: 3 m			Polarization: Horizontal			Date:		
Ambient temperature: 20°C			Position No.: 1H			Relative humidity: 60 %		
Freq. (MHz)	Direct Vdirect (dBμV)	Site Vsite (dBμV)	Transmit Antenna factor AF _T (dB)	Receive Antenna factor AF _R (dB)	Mutual coupling correction AFTOT (dB)	Overall value (dB)	Ideal value (dB)	Difference (dB)
Transmit antenna: Dipole S/No. D 001			Receive antenna: Dipole S/No. D 002					
Transmit antenna cable: Ref. No. C 128			Receive antenna cable: Ref. No. C 129					
Signal generator: Ref. No. SG 001			Receiving device: Ref. No. SA 001					
Attenuator: S/No. AT 01			Attenuator: S/No. AT 02					
Ferrite type: Worry beads			Ferrite manufacturer: Rusty co. Ltd.					

6 Verification procedure

6.1 Introduction

Four procedures, one for each frequency band, are involved in verifying the performance of an anechoic chamber which is used for the frequency range 30 MHz to 40 GHz. The first procedure covers 30 MHz to 1 000 MHz and the second covers 1 GHz to 18 GHz, the third 18 GHz to 26 GHz and the fourth 26 GHz to 40 GHz.

6.2 Procedure 1: 30 MHz to 1 000 MHz

6.2.1 Direct attenuation

- 1) The two antenna cables shall be connected together, via attenuator pads and an "in-line" adapter as shown in figure 6. Alternatively, if this is not practical, a calibrated cable may be used instead of the adapter.

NOTE 1: The use of a cable will increase the overall measurement uncertainty.

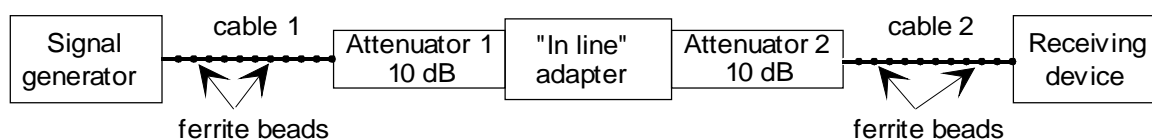

Figure 6: Initial equipment arrangement for the verification tests

- 2) The output of the signal generator shall be adjusted to an appropriate level. The minimum acceptable level for any frequency in the band of interest may be calculated from:
 - 20 dB above the maximum expected radiated path loss ($20 \log((4\pi \text{ range length})/\lambda)$), plus the ambient noise floor, the value of the attenuator pads and the cable losses, minus the antenna gains.

NOTE 2: For practical purposes it is advisable to set a single output level for all frequencies in the band, since this avoids level changes during the verification. Therefore this calculation should be evaluated at 30 MHz, the worst frequency, since the reduced sensitivity of the shortened dipoles at this frequency requires an enhanced signal level 53 dB above that required for tuned half wavelength dipoles. Table 3 indicates the enhancement required for other frequencies where shortened dipoles are used.

EXAMPLE: $20 \text{ dB} + 22 \text{ dB (radiated path loss)} - 110 \text{ dBm (ambient noise floor)} + 20 \text{ dB (attenuator pads)} + 1 \text{ dB (cable losses)} - 4 \text{ dB (antenna gains)} + 53 \text{ dB (enhancement)} = + 2 \text{ dBm (109 dB}\mu\text{V)}$.

Table 3: Enhancement figures for shortened dipoles

Frequency (MHz)	Enhancement (dB)
30	53
35	48
40	43
45	38
50	32
60	19
70	4

If the calculated level is not available then the verification cannot proceed.

Once set, this signal generator output level shall not be adjusted again for the entire duration of the verification process.

- 3) The receiving device and signal generator shall be tuned to the appropriate frequency (starting at the first frequency given in the result sheet shown in table 7). The output level of the signal generator shall be checked (to be certain that the original set level has been maintained) and the received level on the receiving device shall be recorded. For each frequency, the value to be entered in the column headed "Direct" on the results sheet is the sum of this received level plus the loss of the "in-line" adapter or cable at this frequency i.e.:
 - "Direct" value = received level + loss of "in-line" adapter or cable.
- 4) Step 3 shall be repeated for all the frequencies in the results sheet shown in table 7.

6.2.2 Radiated attenuation: Horizontal polarization

- 5) The adapter used to make the direct connection between the attenuator pads shall be removed and the transmit and receive dipoles connected as shown schematically in figure 17.
- 6) The signal generator, receiving device and dipoles shall be tuned to the appropriate frequency (starting at the top of the results sheet shown in table 7).

NOTE 1: For all frequencies below 80 MHz, a shortened dipole (as defined in clause 6.3.3) is used. The dipole arm length is defined as the measured distance from the centre of the balun block to the tip of the arm. From a fully extended state, each telescopic element, in turn, should be "pushed in" from the tip until the required length is obtained. The outermost section needs to fully compress before any of the others, and so on.

- 7) The receiving dipole shall be mounted on the central axis of the chamber and its phase centre shall lie in the plane of symmetry of the chamber (see figure 18). The dipole shall be oriented for horizontal polarization.
- 8) The range length (3 m or 10 m) is defined as the horizontal distance between the receiving dipole and the axis of rotation of the turntable. This shall be set to a tolerance of $\pm 0,01$ m.
- 9) The transmitting dipole shall be mounted in position 1H as shown in figures 14 and 19 and oriented for horizontal polarization. It shall be positioned with its phase centre as follows:
 - a) in the plane of symmetry of the chamber (see figure 18);
 - b) on the axis of rotation of the turntable.
- 10) The output level of the signal generator shall be checked (to ensure that an inadvertent change to the original set level has not occurred) and the received level on the receiving device shall be recorded. This value shall be entered in the results sheet (see table 7) under the column headed "Site".
- 11) Steps 6 to 10 shall be repeated until all the frequencies in the results sheet have been completed, adjusting or changing the dipoles as appropriate.

Table 4: Anechoic chamber verification results sheet (30 MHz to 1 000 MHz)

Anechoic chamber verification procedure results sheet 30 MHz to 1 000 MHz								
Range length: Ambient temperature:			Polarization: Position No.:			Date: Relative humidity:		
Freq. (MHz)	Direct Vdirect (dB μ V)	Site Vsite (dB μ V)	Transmit Antenna factor AF _T (dB)	Receive Antenna factor AF _R (dB)	Mutual coupling correction AFTOT (dB)	Overall value (dB)	Ideal value (dB)	Difference (dB)
30								
35								
40								
45								
50								
60								
70								
80								
90								
100								
120								
140								
160								
180								
200								
250								
300								
400								
500								
600								
700								
800								
900								
1 000								
Transmit antenna: Transmit antenna cable: Signal generator: Attenuator: Ferrite type:				Receive antenna: Receive antenna cable: Receiving device: Attenuator: Ferrite manufacturer:				

- 12) Steps 6 to 11 shall be repeated with the transmitting dipole at the four other positions illustrated in figure 4 and shown as 2H, 3H, 4H and 5H in figure 19. Optionally, steps 6 to 11 should also be repeated for the four extra positions (6H, 7H, 8H and 9H).

NOTE 2: In figures 4 and 9, for both 3 m and 10 m range verification $d = 0,7$ m. The positioning tolerance of all positions relative to position 1H should be $\pm 0,01$ m.

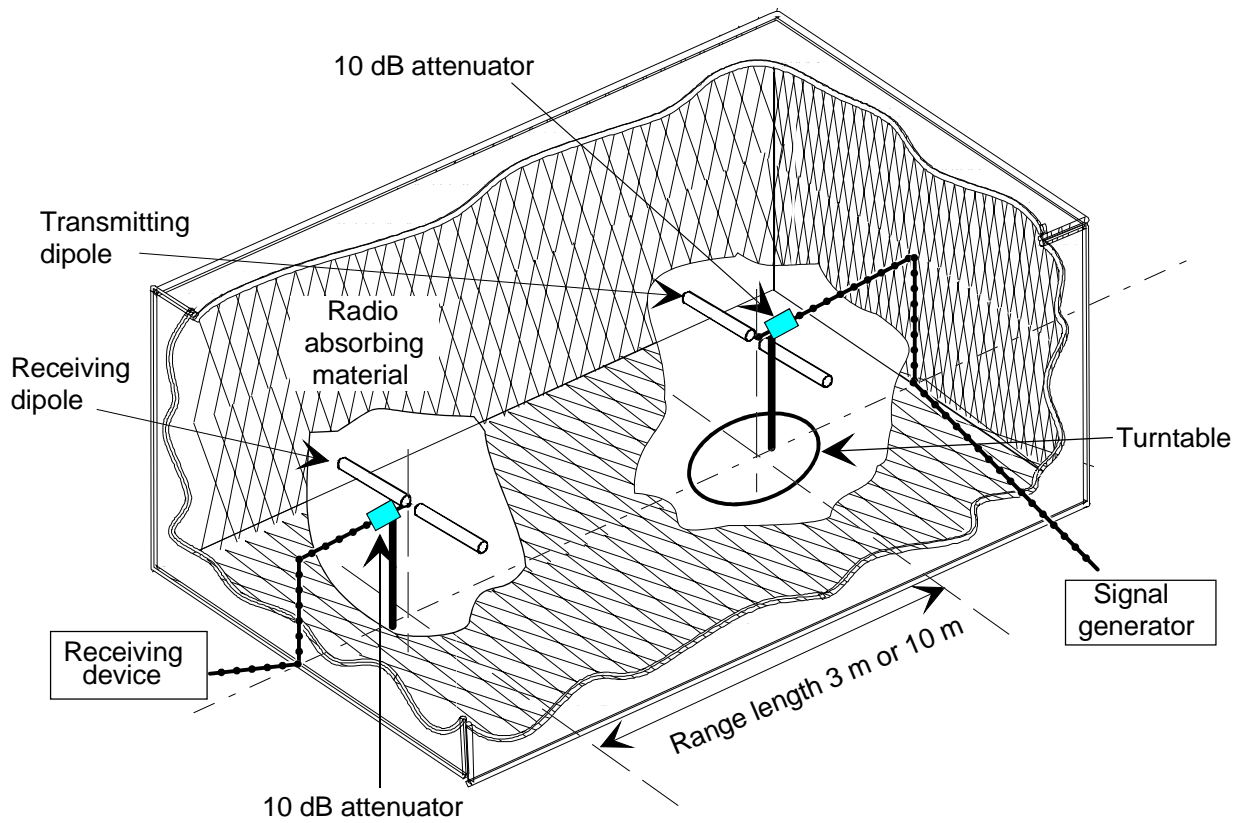

Figure 7: Equipment configuration for verification of an anechoic chamber

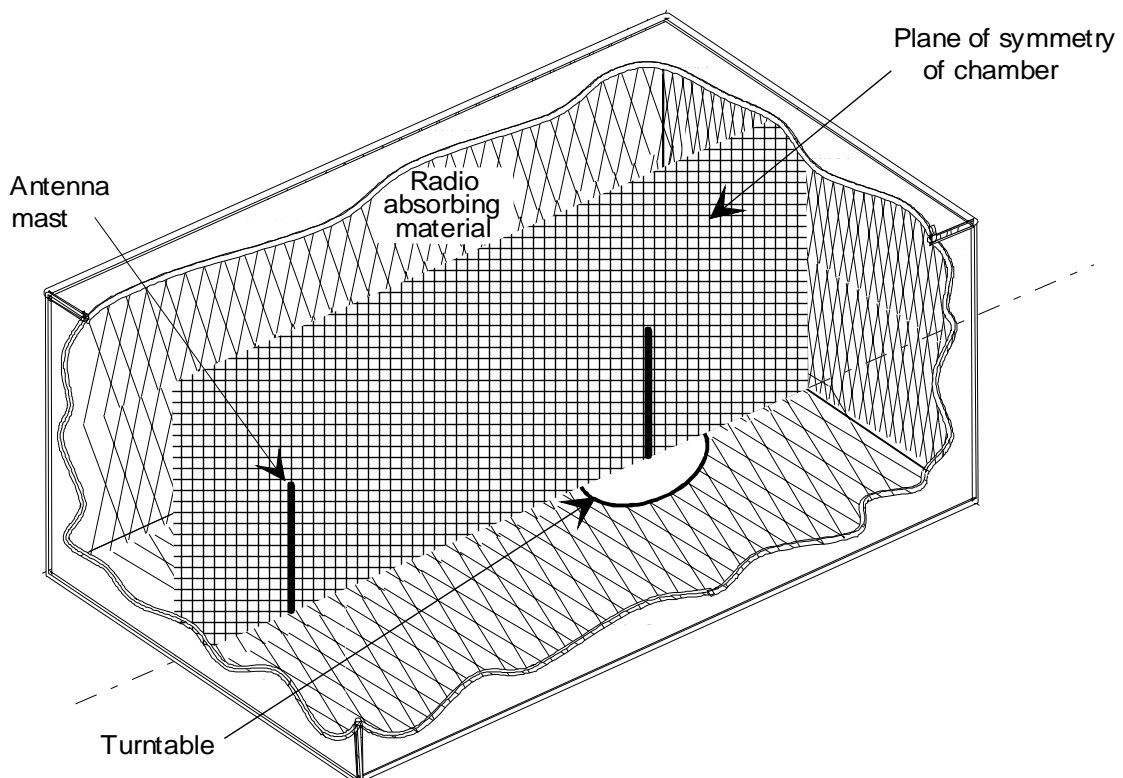

Figure 8: The plane of symmetry of the anechoic chamber

6.2.3 Radiated attenuation: Vertical polarization

- 1) The equipment shall be connected as shown in figure 7 with the dipoles vertically polarized.
- 2) The signal generator, receiving device and dipoles shall be tuned to the appropriate frequency (starting at the top of the results sheet shown in table 7).

NOTE 1: For all frequencies below 80 MHz, a shortened dipole (as defined in clause 6.3.3) is used. The dipole arm length is defined as the measured distance from the centre of the balun block to the tip of the arm. From a fully extended state, each telescopic element, in turn, should be "pushed in" from the tip until the required length is obtained. The outermost section needs to fully compress before any of the others, and so on.

- 3) The receiving dipole shall be mounted on the central axis of the chamber and the whole of its body shall lie in the plane of symmetry of the chamber (see figure 18).
- 4) The range length (3 m or 10 m) is defined as the horizontal distance between the receiving dipole and the axis of rotation of the turntable. This shall be set to a tolerance of $\pm 0,01$ m.
- 5) The transmitting dipole shall be mounted in position 1V as shown in figures 15 and 19 and the whole of its body shall lie in the plane of symmetry of the chamber. Its axis shall lie on the axis of rotation of the turntable.

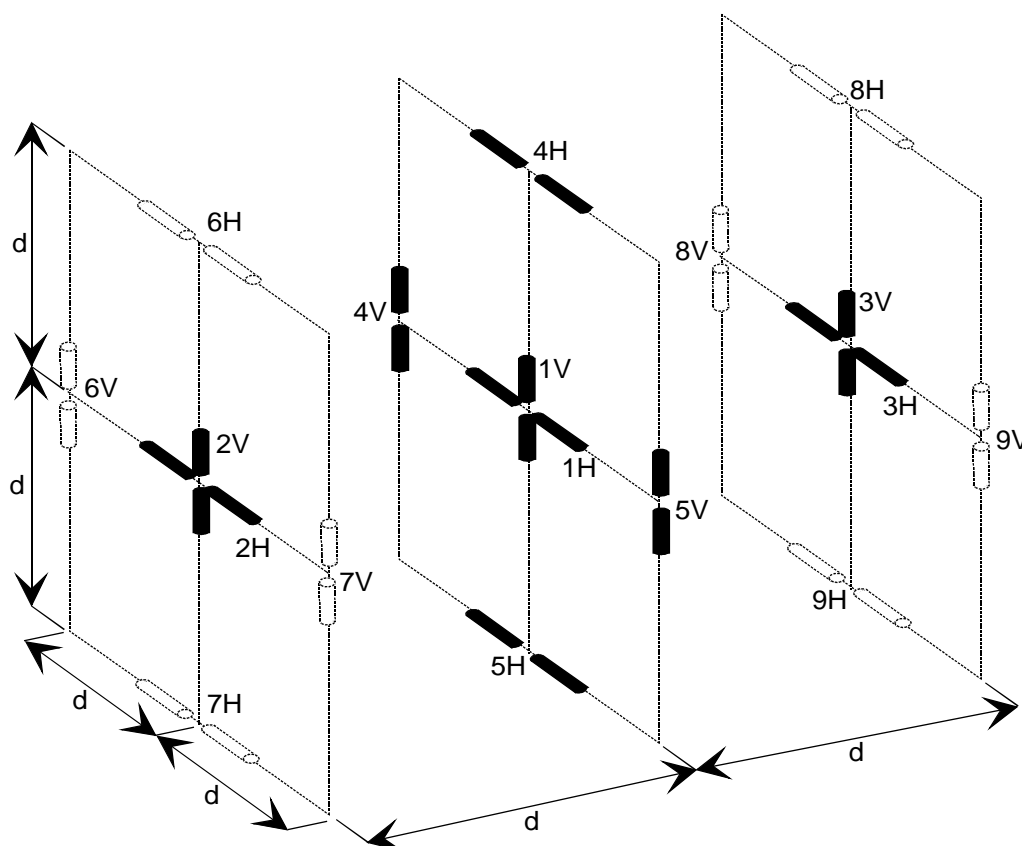

Figure 9: Expanded view of the 5 (optionally 9) transmitting dipole positions

- 6) The output level of the signal generator shall be checked (to ensure that an inadvertent change to the original set level has not occurred) and the received level on the receiving device shall be recorded. This value shall be entered in the result sheet (see table 7) under the column headed "Site".
- 7) Steps 14 to 18 shall be repeated until all the frequencies in the result sheet have been completed, adjusting or changing the dipoles as appropriate.

- 8) Steps 14 to 19 shall be repeated with the transmitting dipole at the four other positions as illustrated in figure 15 and shown as 2V, 3V, 4V and 5V in figure 19. Optionally, steps 14 to 19 shall also be repeated for the four extra positions (6V, 7V, 8V and 9V).

NOTE 2: In figures 15 and 19, for both 3 m and 10 m range verification $d = 0,7$ m. The positioning tolerance of all positions relative to position 1V should be $\pm 0,01$ m.

6.3 Alternative Procedure 1: 30 MHz to 1 000 MHz

The procedure contained in clause 6.2.1 is the most accurate procedure considered for verification in the 30 MHz to 1 000 MHz band. The use of ANSI C63.5 [1] dipoles enables precise correction figures for mutual coupling to be incorporated into the results. The procedure can be very time consuming however and, as a quicker alternative scheme, the following, less accurate procedure may be adopted.

- 1) The procedure, as detailed in clause 6.2.1 shall be completed for positions 1H (for horizontal polarization) and 1V (for vertical polarization).
- 2) Both transmitting and receiving dipoles shall be replaced with biconical antennas (see note 1) for the full 30 MHz to 1 000 MHz band.

NOTE 1: As a further alternative, a biconical antenna 30 MHz to 200 MHz (possibly 300 MHz) may be used with LPDAs for the rest of the band. However, the range length uncertainty associated with the moving phase centre of the LPDAs can significantly increase measurement uncertainty (e.g. a typical design of LPDA with length approximately 1 m, would contribute a range length uncertainty of $u_j = 1,73$ dB over a 3 m range length. This would reduce to $u_j = 0,5$ dB for a 10 m range length but would remain a significant contribution to the overall uncertainty).

CAUTION: For reduced uncertainty in the verification procedure, measurements using alternative antennas should be carried out in the far-fields of the antennas (see clause 7 of TR 102 273-1-1 [6]). For a typical biconical antenna of length 1,315 m, far-field conditions over a 3 m range length only exist from 30 MHz to 60 MHz and not at 70 MHz or above. For a 10 m range length, the corresponding usable frequency range is 30 MHz to 270 MHz.

- 3) The entire verification procedure, as described in steps 1 to 20 of clause 6.2.1, shall be repeated including positions 1H and 1V for the transmitting antenna.

NOTE 2: This alternative procedure does not include any correction factors to account for mutual coupling effects. Whilst these effects are smaller for broadband antennas than for dipoles, there will be increased uncertainty in this alternative verification process because the effects cannot be calculated out of the measurements.

6.4 Procedure 2: 1 GHz to 18 GHz

6.4.1 Direct attenuation

- 1) Connect the two antenna cables together, including the attenuator pads via an "in-line" adapter as shown in figure 10. Alternatively, if this is not practical, a calibrated cable may be used instead of the adapter.

NOTE 1: The use of a cable will increase the overall measurement uncertainty.

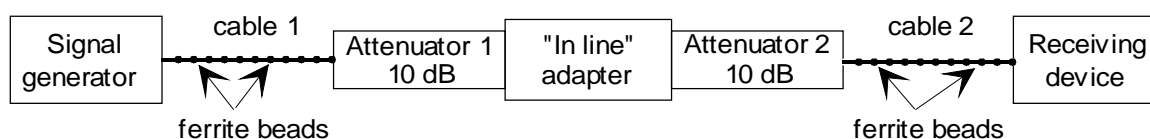

Figure 10: Initial equipment arrangement for the verification tests

- 2) The output of the signal generator shall be adjusted to an appropriate level. The minimum acceptable level for any frequency in the band of interest may be calculated from:

20 dB above the maximum expected radiated path loss ($20 \log ((4\pi \text{ range length})/\lambda)$), plus the ambient noise floor, the value of the attenuator pads and the cable losses, minus the antenna gains.

NOTE 2: For practical purposes it is advisable to set a single output level for all frequencies in the band, since this avoids level changes during the verification.

EXAMPLE: $20 \text{ dB} + 75 \text{ dB (maximum expected path loss)} + (-110 \text{ dB (ambient noise floor)}) + 20 \text{ dB (attenuator pads)} + 15 \text{ dB (cable losses)} - 10 \text{ dB (antenna gains)} = +10 \text{ dBm (117 dB}\mu\text{V)}$.

If the calculated level is not available then the verification cannot proceed.

Once set, this signal generator output level shall not be adjusted again for the entire duration of the verification procedure.

- 3) The receiving device and signal generator shall be tuned to the appropriate frequency (starting at the first frequency given in the result sheet shown in table 8). The output level of the signal generator should be checked (to be certain that the original set level has been maintained) and the received level on the receiving device shall be recorded. For each frequency, the value to be entered under the column headed "Direct" on the results sheet is the sum of this received level plus the loss of the "in-line" adapter or cable i.e.:

"Direct" value = received level + loss of "In-line" adapter or cable.

- 4) Step 3 shall be repeated for all frequencies in the results sheet shown in table 8.

6.4.2 Radiated attenuation: Horizontal polarization

- 5) The adapter used to make the direct connection between the attenuator pads shall be removed and the transmit and receive antennas shall be connected as shown in figure 22 with the LPDAs horizontally polarized.

NOTE 1: In order to minimize the uncertainty in range length which results from using LPDAs (the radiating phase centre moves with frequency), the radiating phase centre is defined, for the purposes of these measurements only, as the point on the log periodic central axis where its thickness is 0,08 m. This is shown in figure 11.

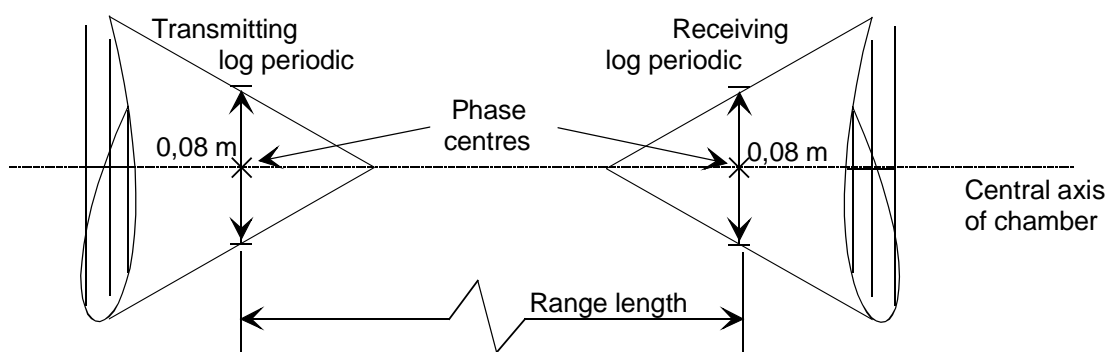

Figure 11: Definition of phase centres of the LPDA

- 6) The receiving antenna shall be positioned with its central axis coincident with the central axis of the chamber.
- 7) The horizontal spacing between the phase centre of the receiving LPDA and the centre of the turntable is the range length. This shall be set to a tolerance of $\pm 0,01 \text{ m}$.
- 8) The transmitting antenna shall be mounted in position 1H as shown in figures 14 and 19, with its central axis coincident with the central axis of the chamber. The phase centre of the transmitting antenna shall lie on the axis of rotation of the turntable.
- 9) The signal generator and receiving device shall be tuned to the appropriate frequency (starting at the top of the results sheet shown in table 8).

- 10) The output level of the signal generator shall be checked (to ensure that an inadvertent change to the original set level has not occurred) and the received level on the receiving device shall be recorded. This value shall be entered in the results sheet (see table 8) under the column headed "Site".
- 11) Steps 9 and 10 shall be repeated until all the frequencies in the results sheet (see table 8) have been completed.
- 12) Steps 9, 10 and 11 shall be repeated with the transmitting antenna at the four other positions as illustrated in figure 14 and shown as 2H, 3H, 4H and 5H in figure 19. Optionally, steps 9, 10 and 11 shall also be repeated for the four extra positions (6H, 7H, 8H and 9H).

NOTE 2: In figures 12 and 17 for both 3 m and 10 m range length verifications, $d = 0,7\text{m}$. The positioning tolerance of the phase centres of all positions relative to position 1H should be $\pm 0,01\text{ m}$.

NOTE 3: For all positions, both antennas needs to point directly towards each other, consistent with keeping their central axes parallel to the floor. For all transmitting positions other than 1H, 2H and 3H in figure 19, this will involve small angle rotation of both receiving and transmitting antennas. For both antennas, this rotation should be about the phase centre.

6.4.3 Radiated attenuation: Vertical polarization

- 13) The equipment shall be connected as shown in figure 12.

NOTE 1: In order to minimize the uncertainty in range length which results from using LPDAs (the radiating phase centre moves with frequency), the radiating phase centre is defined, for the purposes of these measurements, as the point on the LPDA's central axis where its thickness is 0,08 m. This is shown in figure 21.

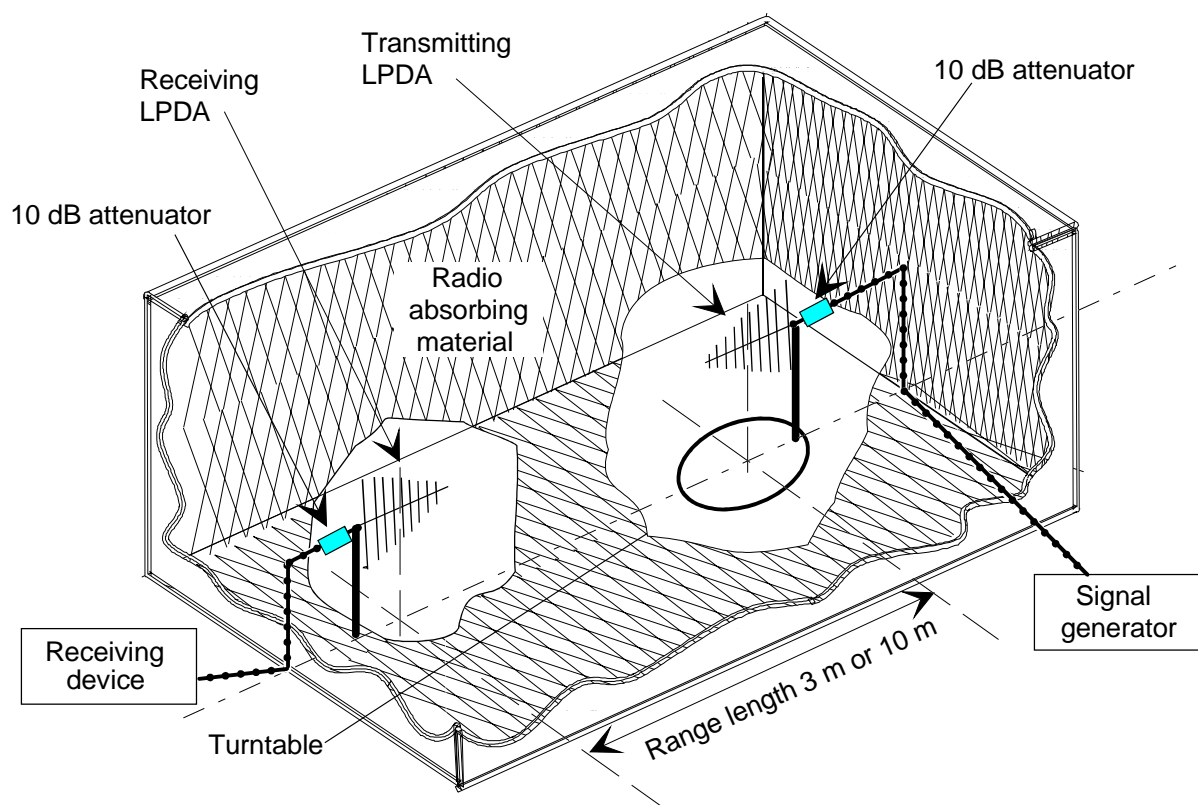

Figure 12: Anechoic chamber layout for verification with LPDAs

- 14) The receiving antenna shall be positioned with its central axis coincident with the central axis of the chamber. It shall be oriented for vertical polarization.
- 15) The horizontal spacing between the phase centre of the LPDA and the centre of the turntable is the range length. This shall be set to a tolerance of $\pm 0,01\text{ m}$.

- 16) The transmitting antenna shall be mounted in position 1V as shown in figures 5 and 9 with its central axis coincident with the central axis of the chamber. The phase centre of the transmitting antenna shall lie on the axis of rotation of the turntable. The transmitting antenna shall be oriented for vertical polarization.
- 17) The signal generator and receiving device shall be tuned to the appropriate frequency (starting at the top of the results sheet shown in table 8).
- 18) The output level of the signal generator shall be checked (to ensure that an inadvertent change to the original set level has not occurred) and the received level on the receiving device shall be recorded. This value shall be entered in the results sheet (see table 8) under the column headed "Site".
- 19) Steps 17 and 18 shall be repeated until all the frequencies in the results sheet (see table 8) have been completed.
- 20) Steps 17, 18 and 19 shall be repeated with the transmitting dipole at the four other positions as illustrated in figure 15 and shown as 2V, 3V, 4V and 5V in figure 19. Optionally, steps 17, 18 and 19 shall also be repeated for the four extra positions (6V, 7V, 8V and 9V).

NOTE 2: In figures 13 and 17, for both 3 m and 10 m range length verifications $d = 0,7$ m. The positioning tolerance of the phase centres of all positions relative to position 1V should be $\pm 0,01$ m.

NOTE 3: For all positions, both antennas needs to point directly towards each other, consistent with keeping their central axes parallel to the floor. For all transmitting positions other than 1V, 2V and 3V in figure 19, this will involve small angle rotation of both receiving and transmitting antennas. For both antennas, this rotation should be about the phase centre.

Table 5: Anechoic chamber verification results sheet (1 GHz to 18 GHz)

Anechoic chamber verification procedure results sheet 1 GHz to 18 GHz							
Range length:		Polarization:			Date:		
Ambient temperature:			Position No.:				
Relative humidity:							
Freq. (GHz)	Direct Vdirect (dBμV)	Site Vsite (dBμV)	Transmit Antenna factor AF _T (dB)	Receive Antenna factor AF _R (dB)	Overall value (dB)	Ideal value (dB)	Difference (dB)
1,0							
1,25							
1,5							
1,75							
2,0							
2,25							
2,5							
2,75							
3,0							
3,25							
3,5							
3,75							
4,0							
4,5							
5,0							
5,5							
6,0							
6,5							
7,0							
7,5							
8,0							
8,5							
9,0							
9,5							
10,0							
10,5							
11,0							
11,5							
12,0							
12,5							
13							
13,5							
14							
14,5							
15							
15,5							
16							
16,5							
17							
17,5							
18							
Transmit antenna: Transmit antenna cable: Signal generator: Attenuator: Ferrite type:				Receive antenna: Receive antenna cable: Receiving device: Attenuator: Ferrite manufacturer:			

6.5 Procedure 3: 18 GHz to 26 GHz

6.5.1 Direct attenuation

- 1) Connect the two antenna cables together, including the attenuator pads via an "in-line" adapter as shown in figure 13. Alternatively, if this is not practical, a calibrated cable may be used instead of the adapter.

NOTE 1: The use of a cable will increase the overall measurement uncertainty.

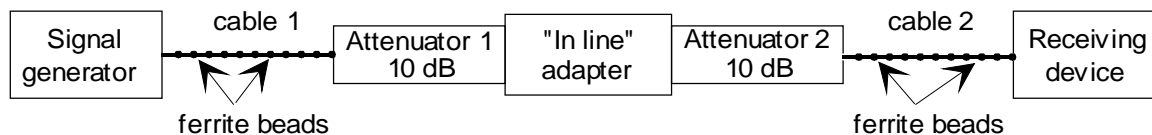

Figure 13: Initial equipment arrangement for the verification tests

- 2) The output of the signal generator shall be adjusted to an appropriate level. The minimum acceptable level for any frequency in the band of interest may be calculated from:
 - 20 dB above the maximum expected radiated path loss ($20 \log((4\pi \text{ range length})/\lambda)$), plus the ambient noise floor, the value of the attenuator pads and the cable losses, minus the antenna gains.

NOTE 2: For practical purposes it is advisable to set a single output level for all frequencies in the band, since this avoids level changes during the verification.

EXAMPLE: $20 \text{ dB} + 75 \text{ dB}$ (maximum expected path loss) + $(- 110 \text{ dB})$ (ambient noise floor) + 20 dB (attenuator pads) + 15 dB (cable losses) - 10 dB (antenna gains) = $+10 \text{ dBm}$ ($117 \text{ dB}\mu\text{V}$).

If the calculated level is not available then the verification cannot proceed.

Once set, this signal generator output level shall not be adjusted again for the entire duration of the verification procedure.

- 3) The receiving device and signal generator shall be tuned to the appropriate frequency (starting at the first frequency given in the result sheet shown in table 8). The output level of the signal generator should be checked (to be certain that the original set level has been maintained) and the received level on the receiving device shall be recorded. For each frequency, the value to be entered under the column headed "Direct" on the results sheet is the sum of this received level plus the loss of the "in-line" adapter or cable i.e.:
 - "Direct" value = received level + loss of "In-line" adapter or cable.
- 4) Step 3 shall be repeated for all frequencies in the results sheet shown in table 8.

6.5.2 Radiated attenuation: Horizontal polarization

- 5) The adapter used to make the direct connection between the attenuator pads shall be removed and the transmit and receive antennas shall be connected as shown in figure 22 with the standard gain horns horizontally polarized.
- 6) The receiving antenna shall be positioned with its central axis coincident with the central axis of the chamber.
- 7) The horizontal spacing between the phase centre of the receiving LPDA and the centre of the turntable is the range length. This shall be set to a tolerance of $\pm 0,01 \text{ m}$.
- 8) The transmitting antenna shall be mounted in position 1H as shown in figures 14 and 19, with its central axis coincident with the central axis of the chamber. The phase centre of the transmitting antenna shall lie on the axis of rotation of the turntable.
- 9) The signal generator and receiving device shall be tuned to the appropriate frequency (starting at the top of the results sheet shown in table 8).

- 10) The output level of the signal generator shall be checked (to ensure that an inadvertent change to the original set level has not occurred) and the received level on the receiving device shall be recorded. This value shall be entered in the results sheet (see table 8) under the column headed "Site".
- 11) Steps 9 and 10 shall be repeated until all the frequencies in the results sheet (see table 8) have been completed.
- 12) Steps 9, 10 and 11 shall be repeated with the transmitting antenna at the four other positions as illustrated in figure 14 and shown as 2H, 3H, 4H and 5H in figure 19. Optionally, steps 9, 10 and 11 shall also be repeated for the four extra positions (6H, 7H, 8H and 9H).

NOTE: For all positions, both antennas need to point directly towards each other, consistent with keeping their central axes parallel to the floor. For all transmitting positions other than 1H, 2H and 3H in figure 19, this will involve small angle rotation of both receiving and transmitting antennas. For both antennas, this rotation should be about the phase centre.

6.5.3 Radiated attenuation: Vertical polarization

- 13) The equipment shall be connected as shown in figure 14.

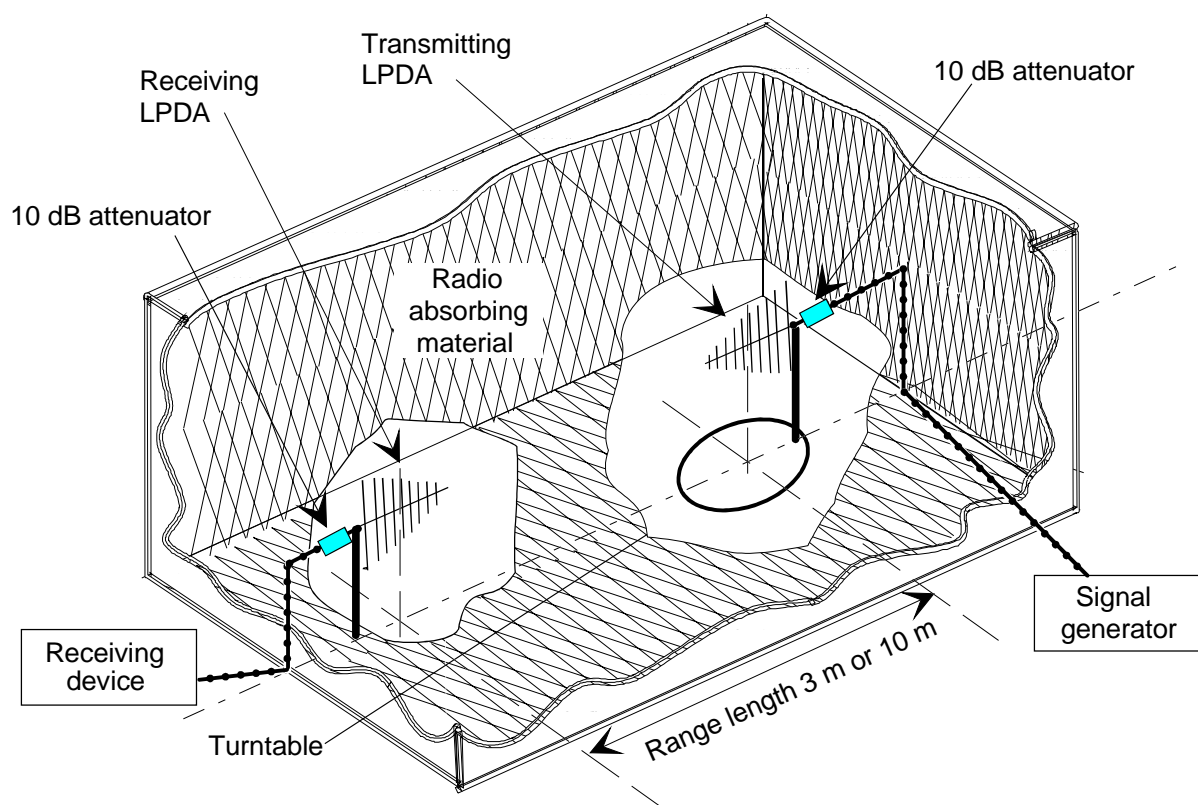

Figure 14: Anechoic chamber layout for verification with LPDAs

- 14) The receiving antenna shall be positioned with its central axis coincident with the central axis of the chamber. It shall be oriented for vertical polarization.
- 15) The horizontal spacing between the front face of the standard gain horn and the centre of the turntable is the range length. This shall be set to a tolerance of $\pm 0,01$ m.
- 16) The transmitting antenna shall be mounted in position 1V as shown in figures 15 and 19 with its central axis coincident with the central axis of the chamber. The front face of the transmitting antenna shall lie on the axis of rotation of the turntable. The transmitting antenna shall be oriented for vertical polarization.
- 17) The signal generator and receiving device shall be tuned to the appropriate frequency (starting at the top of the results sheet shown in table 8).

- 18) The output level of the signal generator shall be checked (to ensure that an inadvertent change to the original set level has not occurred) and the received level on the receiving device shall be recorded. This value shall be entered in the results sheet (see table 8) under the column headed "Site".
- 19) Steps 17 and 18 shall be repeated until all the frequencies in the results sheet (see table 8) have been completed.
- 20) Steps 17, 18 and 19 shall be repeated with the transmitting antenna at the four other positions as illustrated in figure 15 and shown as 2V, 3V, 4V and 5V in figure 19. Optionally, steps 17, 18 and 19 shall also be repeated for the four extra positions (6V, 7V, 8V and 9V).

NOTE 1: In figures 13 and 17, for both 3 m and 10 m range length verifications $d = 0,7$ m. The positioning tolerance of the front face of the standard gain horn of all positions relative to position 1V should be $\pm 0,01$ m.

NOTE 2: For all positions, both antennas needs to point directly towards each other, consistent with keeping their central axes parallel to the floor. For all transmitting positions other than 1V, 2V and 3V in figure 19, this will involve small angle rotation of both receiving and transmitting antennas. For both antennas, this rotation should be about the front face centre.

Table 6: Anechoic chamber verification results sheet (18 GHz to 26 GHz)

Anechoic chamber verification procedure results sheet 18 GHz to 26 GHz							
Range length: Ambient temperature:			Polarization: Position No.:		Date: Relative humidity:		
Freq. (GHz)	Direct Direct (dB μ V)	Site Vista (dB μ V)	Transmit Antenna factor AF _T (dB)	Receive Antenna factor AF _R (dB)	Overall value (dB)	Ideal value (dB)	Difference (dB)
18,0							
18,5							
19							
19,5							
20							
20,5							
21							
21,5							
22							
22,5							
23							
23,5							
24							
24,5							
25							
25,5							
26							
Transmit antenna: Transmit antenna cable: Signal generator: Attenuator: Ferrite type:				Receive antenna: Receive antenna cable: Receiving device: Attenuator: Ferrite manufacturer:			

6.6 Procedure 4: 26 GHz to 40 GHz

6.6.1 Direct attenuation

- 1) Connect the two antenna cables together, including the attenuator pads via an "in-line" adapter as shown in figure 15. Alternatively, if this is not practical, a calibrated cable may be used instead of the adapter.

NOTE 1: The use of a cable will increase the overall measurement uncertainty.

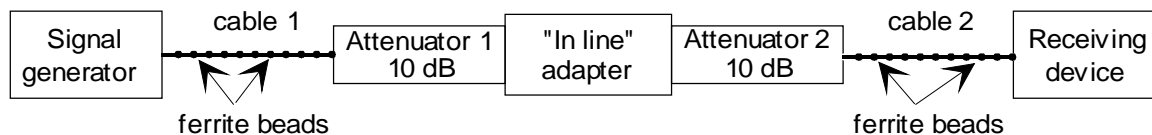

Figure 15: Initial equipment arrangement for the verification tests

- 2) The output of the signal generator shall be adjusted to an appropriate level. The minimum acceptable level for any frequency in the band of interest may be calculated from:
 - 20 dB above the maximum expected radiated path loss ($20 \log((4\pi \text{ range length})/\lambda)$), plus the ambient noise floor, the value of the attenuator pads and the cable losses, minus the antenna gains.

NOTE 2: For practical purposes it is advisable to set a single output level for all frequencies in the band, since this avoids level changes during the verification.

EXAMPLE: $20 \text{ dB} + 75 \text{ dB}$ (maximum expected path loss) + (-110 dB) (ambient noise floor) + 20 dB (attenuator pads) + 15 dB (cable losses) - 10 dB (antenna gains) = $+10 \text{ dBm}$ ($117 \text{ dB}\mu\text{V}$).

If the calculated level is not available then the verification cannot proceed.

Once set, this signal generator output level shall not be adjusted again for the entire duration of the verification procedure.

- 3) The receiving device and signal generator shall be tuned to the appropriate frequency (starting at the first frequency given in the result sheet shown in table 8). The output level of the signal generator should be checked (to be certain that the original set level has been maintained) and the received level on the receiving device shall be recorded. For each frequency, the value to be entered under the column headed "Direct" on the results sheet is the sum of this received level plus the loss of the "in-line" adapter or cable i.e.:
 - "Direct" value = received level + loss of "In-line" adapter or cable.
- 4) Step 3 shall be repeated for all frequencies in the results sheet shown in table 8.

6.6.2 Radiated attenuation: Horizontal polarization

- 5) The adapter used to make the direct connection between the attenuator pads shall be removed and the transmit and receive antennas shall be connected as shown in figure 22 with the standard gain horns horizontally polarized.
- 6) The receiving antenna shall be positioned with its central axis coincident with the central axis of the chamber.
- 7) The horizontal spacing between the phase centre of the receiving standard gain horn and the centre of the turntable is the range length. This shall be set to a tolerance of $\pm 0,01 \text{ m}$.
- 8) The transmitting antenna shall be mounted in position 1H as shown in figures 14 and 19, with its central axis coincident with the central axis of the chamber. The front face of the transmitting antenna shall lie on the axis of rotation of the turntable.
- 9) The signal generator and receiving device shall be tuned to the appropriate frequency (starting at the top of the results sheet shown in table 8).

- 10) The output level of the signal generator shall be checked (to ensure that an inadvertent change to the original set level has not occurred) and the received level on the receiving device shall be recorded. This value shall be entered in the results sheet (see table 8) under the column headed "Site".
- 11) Steps 9 and 10 shall be repeated until all the frequencies in the results sheet (see table 8) have been completed.
- 12) Steps 9, 10 and 11 shall be repeated with the transmitting antenna at the four other positions as illustrated in figure 14 and shown as 2H, 3H, 4H and 5H in figure 19. Optionally, steps 9, 10 and 11 shall also be repeated for the four extra positions (6H, 7H, 8H and 9H).

NOTE 1: In figures 12 and 17 for both 3 m and 10 m range length verifications, $d = 0,7\text{m}$. The positioning tolerance of the front faces of all positions relative to position 1H should be $\pm 0,01\text{ m}$.

NOTE 2: For all positions, both antennas need to point directly towards each other, consistent with keeping their central axes parallel to the floor. For all transmitting positions other than 1H, 2H and 3H in figure 19, this will involve small angle rotation of both receiving and transmitting antennas. For both antennas, this rotation should be about the front face.

6.6.3 Radiated attenuation: Vertical polarization

- 13) The equipment shall be connected as shown in figure 16.

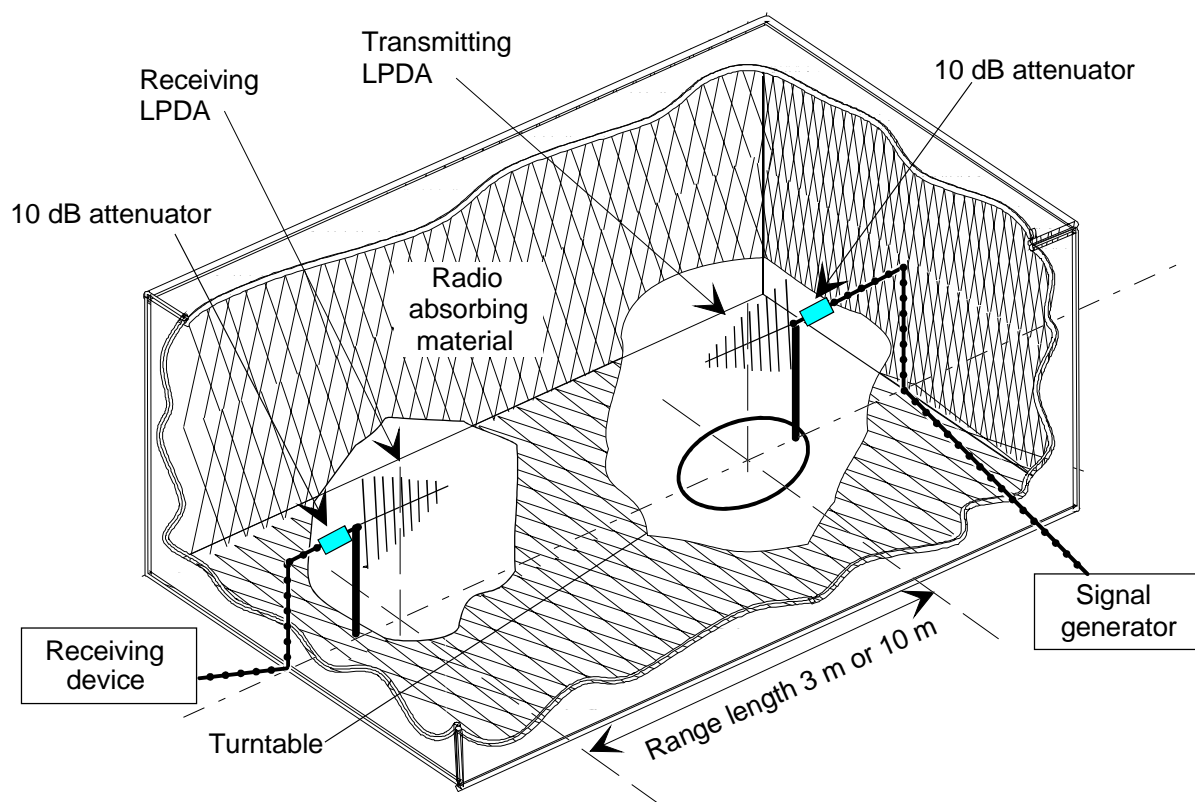

Figure 16: Anechoic chamber layout for verification

- 14) The receiving antenna shall be positioned with its central axis coincident with the central axis of the chamber. It shall be oriented for vertical polarization.
- 15) The horizontal spacing between the front face of the standard gain horn and the centre of the turntable is the range length. This shall be set to a tolerance of $\pm 0,01\text{ m}$.
- 16) The transmitting antenna shall be mounted in position 1V as shown in figures 15 and 19 with its central axis coincident with the central axis of the chamber. The phase centre of the transmitting antenna shall lie on the axis of rotation of the turntable. The transmitting antenna shall be oriented for vertical polarization.
- 17) The signal generator and receiving device shall be tuned to the appropriate frequency (starting at the top of the results sheet shown in table 8).

- 18) The output level of the signal generator shall be checked (to ensure that an inadvertent change to the original set level has not occurred) and the received level on the receiving device shall be recorded. This value shall be entered in the results sheet (see table 8) under the column headed "Site".
- 19) Steps 17 and 18 shall be repeated until all the frequencies in the results sheet (see table 8) have been completed.
- 20) Steps 17, 18 and 19 shall be repeated with the transmitting standard gain horn at the four other positions as illustrated in figure 15 and shown as 2V, 3V, 4V and 5V in figure 19. Optionally, steps 17, 18 and 19 shall also be repeated for the four extra positions (6V, 7V, 8V and 9V).

NOTE 1: In figures 13 and 17, for both 3 m and 10 m range length verifications $d = 0,7$ m. The positioning tolerance of the front face of all positions relative to position 1V should be $\pm 0,01$ m.

NOTE 2: For all positions, both antennas needs to point directly towards each other, consistent with keeping their central axes parallel to the floor. For all transmitting positions other than 1V, 2V and 3V in figure 19, this will involve small angle rotation of both receiving and transmitting antennas. For both antennas, this rotation should be about the front face.

Table 7: Anechoic chamber verification results sheet (26 GHz to 40 GHz)

Anechoic chamber verification procedure results sheet 26 GHz to 40 GHz							
Range length: Ambient temperature:			Polarization: Position No.:		Date: Relative humidity:		
Freq. (GHz)	Direct Direct (dB μ V)	Site Vista (dB μ V)	Transmit Antenna factor AF _T (dB)	Receive Antenna factor AF _R (dB)	Overall value (dB)	Ideal value (dB)	Difference (dB)
26							
26,5							
27							
27,5							
28							
28,5							
29							
29,5							
30							
30,5							
31							
31,5							
32							
32,5							
33							
33,5							
34							
34,5							
35							
35,5							
36							
36,5							
37							
37,5							
38							
38,5							
39							
39,5							
40							
Transmit antenna: Transmit antenna cable: Signal generator: Attenuator: Ferrite type:				Receive antenna: Receive antenna cable: Receiving device: Attenuator: Ferrite manufacturer:			

7 Processing the results of the verification procedure

7.1 Introduction

Having carried out the verification procedures as detailed in clause 6.4 the results sheets should have values filling the first three columns, namely those headed "Freq", "Direct" and "Site". This clause details the values to be incorporated in all the remaining columns.

The processing of the results finally reveals how well the measured performance of the anechoic chamber compares to the ideal case.

Firstly, the figures for entering under the column headings of "Transmit Antenna factor, AF_T " and "Receive Antenna factor, AF_R " are discussed and values are provided. Secondly, for the 30 MHz to 1 000 MHz verification procedure only, correction factors are provided for the recommended antenna scheme (ANSI C63.5 [1] dipoles) to allow for the effects of mutual coupling and mismatch loss. These effects are regarded as not significant at frequencies above 180 MHz and enable the column headed "Mutual coupling correction, AF_{TOT} " to be completed. The "Overall value" column can then be calculated. This column reveals the measured NSA for the anechoic chamber.

Finally, having extracted the relevant values (from tables provided) to complete the "Ideal value" column, the difference between the measured performance and the ideal can be calculated by simple subtraction of the values in the columns "Overall value" and "Ideal value".

7.2 Procedure 1: 30 MHz to 1 000 MHz

7.2.1 Antenna factors

For dipoles, the antenna factor of each dipole is given by:

$$\text{Antenna factor} = 20 \log f - 31,4 \text{ dB}$$

where f is the frequency in MHz.

NOTE 1: A resistive loss of 0,5 dB is incorporated into this formula.

Whilst the above formula for antenna factor applies only to a tuned half wavelength dipole, it should still be used in this verification procedure, even where shortened dipoles have been used (the 30 MHz to 70 MHz band). Table 9 gives the values at the test frequencies. The relevant values should be entered in the verification results sheet (see table 7) in the columns headed "Transmit Antenna factor, AF_T " and "Receive Antenna factor, AF_R ".

NOTE 2: Table 9 applies for both horizontal and vertical polarization.

When antennas other than dipoles are used, antenna factors are usually provided by the manufacturers. Where gain figures, rather than antenna factors, have been given, these can be converted into antenna factor by the following equation:

$$\text{Antenna factor} = 20 \log \left(\frac{9,734}{\lambda \sqrt{G}} \right) \text{ dB} \quad (6.5)$$

where:

λ is the wavelength (m);

G is the numeric gain.

NOTE 3: The gain figure to be used should be relative to an isotropic radiator - not relative to a dipole.

Table 8: Antenna factor for a dipole used in the verification procedure.

Frequency (MHz)	Antenna factor (dB)	Frequency (MHz)	Antenna factor (dB)
30	-1,9	160	12,7
35	-0,5	180	13,7
40	0,6	200	14,6
45	1,7	250	16,6
50	2,6	300	18,1
60	4,2	400	20,6
70	5,5	500	22,6
80	6,7	600	24,2
90	7,7	700	25,5
100	8,6	800	26,7
120	10,2	900	27,7
140	11,5	1 000	28,6

7.2.2 Mutual coupling and mismatch loss correction factors

Table 10 gives the factors necessary to correct the measured figures not only for mutual coupling, but also for mismatch transmission loss - this being the dominant term for frequencies up to 70 MHz. The table applies for both vertical and horizontal polarization.

NOTE 1: Particularly at low frequencies (i.e. up to 180 MHz) the performance of each antenna used in the verification procedure is affected by the presence of the other antenna. This interaction between antennas is termed mutual coupling and has been modelled by computer simulation for the recommended antenna scheme (ANSI dipoles) only.

For the recommended dipole antenna scheme only, the relevant figures should be taken from table 10 and entered in the results sheet (see table 7) in the column headed "Mutual coupling correction AF_{TOT} ". For all frequencies above 180 MHz, the correction factor should be taken as 0,0 dB.

For the alternative antenna schemes (bicones only or bicones and log periodics) all entries in the "Mutual coupling correction AF_{TOT} " column should be 0,0 dB.

Table 9: Mutual coupling and mismatch loss correction factors

Range lengths and transmitting dipole positions:													
Range length: 3 m Various positions							Range length: 10 m Various positions						
Freq (MHz)	1H 1V	2H 2V	3H 3V	4H, 4V 5H, 5V	6H, 6V 7H, 7V	8H, 8V 9H, 9V	1H 1V	2H 2V	3H 3V	4H, 4V 5H, 5V	6H, 6V 7H, 7V	8H, 8V 9H, 9V	
30	52,7	53,3	52,3	52,6	53,1	52,3	51,5	51,5	51,5	51,5	51,5	51,5	
35	47,5	48,1	47,1	47,4	48,0	47,1	46,5	46,5	46,4	46,5	46,5	46,4	
40	42,4	42,9	42,1	42,3	42,8	42,0	41,5	41,5	41,5	41,5	41,5	41,5	
45	37,1	37,6	36,8	37,1	37,5	36,8	36,3	36,3	36,3	36,3	36,3	36,3	
50	31,5	31,9	31,2	31,4	31,8	31,2	30,7	30,8	30,7	30,7	30,8	30,7	
60	18,7	19,1	18,5	18,7	19,0	18,5	18,1	18,1	18,1	18,1	18,1	18,1	
70	3,8	4,4	3,6	3,7	4,3	3,6	3,2	3,3	3,3	3,3	3,3	3,3	
80	0,7	1,0	0,7	0,9	0,9	0,7	0,2	0,3	0,2	0,2	0,3	0,2	
90	0,6	0,9	0,3	0,6	0,5	0,3	0,1	0,0	0,0	0,1	0,0	0,0	
100	0,6	0,5	0,2	0,5	0,5	0,2	0,1	0,1	0,1	0,1	0,1	0,1	
120	0,3	0,8	0,5	0,3	0,8	0,4	0,2	0,2	0,2	0,2	0,2	0,2	
140	0,5	0,6	0,4	0,2	0,5	0,3	0,2	0,2	0,2	0,2	0,2	0,3	
160	0,4	0,4	0,4	0,4	0,4	0,4	0,3	0,3	0,2	0,3	0,3	0,3	
180	0,3	0,5	0,3	0,3	0,5	0,3	0,2	0,2	0,2	0,2	0,2	0,2	

7.2.3 Completion of the results sheet

The next stage is to enter values in the column headed "Overall value". This is achieved by performing the following calculation:

$$\text{"Overall value"} = \text{"V}_{\text{direct}} - \text{"V}_{\text{site}} - \text{"AF}_{\text{T}} - \text{"AF}_{\text{R}} - \text{"AF}_{\text{TOT}}$$

The resulting value is the measured NSA for the anechoic chamber.

The final stages in determining the quality of the site are to complete the column headed "Ideal value" in the results sheet (see table 7) by taking the relevant values from table 11 and to calculate the entries for the "Difference" column from:

- "Difference" "Overall value" - "Ideal value"

The values in the "Difference" column represent the variation between the theoretical and the measured NSA of the anechoic chamber.

Table 10: Theoretical ideal values for NSA

Ideal NSA (dB)												
Freq. (MHz)	Range length: 3 m Various positions						Range length: 10 m Various positions					
	1H 1V	2H 2V	3H 3V	4H, 4V 5H, 5V	6H, 6V 7H, 7V	8H, 8V 9H, 9V	1H 1V	2H 2V	3H 3V	4H, 4V 5H, 5V	6H, 6V 7H, 7V	8H, 8V 9H, 9V
30	12,0	9,7	13,8	12,2	10,1	14,0	22,5	21,8	23,1	22,5	21,9	23,1
35	10,7	8,4	12,5	10,9	8,7	12,6	21,1	20,5	21,7	21,1	20,5	21,7
40	9,5	7,2	11,3	9,7	7,6	11,5	20,0	19,3	20,6	20,0	19,4	20,6
45	8,5	6,2	10,3	8,7	6,6	10,5	19,0	18,3	19,5	19,0	18,3	19,5
50	7,6	5,3	9,4	7,8	5,6	9,5	18,0	17,4	18,6	18,0	17,4	18,6
60	6,0	3,7	7,8	6,2	4,1	8,0	16,4	15,8	17,0	16,5	15,8	17,0
70	4,6	2,3	6,5	4,9	2,7	6,6	15,1	14,5	15,7	15,1	14,5	15,7
80	3,5	1,2	5,3	3,7	1,6	5,5	13,9	13,3	14,5	14,0	13,3	14,6
90	2,5	0,2	4,3	2,7	0,5	4,4	12,9	12,3	13,5	13,0	12,3	13,5
100	1,5	-0,8	3,4	1,8	-0,4	3,5	12,0	11,4	12,6	12,0	11,4	12,6
120	0,0	-2,4	1,8	0,2	-2,0	1,9	10,4	9,8	11,0	10,4	9,8	11,0
140	-1,4	-3,7	0,4	-1,2	-3,3	0,6	9,1	8,5	9,7	9,1	8,5	9,7
160	-2,5	-4,9	-0,7	-2,3	-4,5	-0,6	7,9	7,3	8,5	8,0	7,3	8,5
180	-3,6	-5,9	-1,7	-3,3	-5,5	-1,6	6,9	6,3	7,5	7,0	6,3	7,5
200	-4,5	-6,8	-2,7	-4,3	-6,4	-2,5	6,0	5,4	6,6	6,0	5,4	6,6
250	-6,4	-8,7	-4,6	-6,2	-8,3	-4,4	4,0	3,4	4,6	4,1	3,4	4,7
300	-8,0	-10,3	-6,2	-7,8	-9,9	-6,0	2,5	1,8	3,1	2,5	1,9	3,1
400	-10,5	-12,8	-8,7	-10,3	-12,4	-8,5	-0,0	-0,7	0,6	0,0	-0,7	0,6
500	-12,4	-14,7	-10,6	-12,2	-14,4	-10,5	-2,0	-2,6	-1,4	-2,0	-2,6	-1,4
600	-14,0	-16,3	-12,2	-13,8	-15,9	-12,1	-3,6	-4,2	-3,0	-3,5	-4,2	-3,0
700	-15,4	-17,7	-13,5	-15,1	-17,3	-13,4	-4,9	-5,5	-4,3	-4,9	-5,5	-4,3
800	-16,5	-18,8	-14,7	-16,3	-18,4	-14,5	-6,1	-6,7	-5,5	-6,0	-6,7	-5,5
900	-17,5	-19,9	-15,7	-17,3	-19,5	-15,6	-7,1	-7,7	-6,5	-7,1	-7,7	-6,5
1 000	-18,5	-20,8	-16,6	-18,2	-20,4	-16,5	-8,0	-8,6	-7,4	-8,0	-8,6	-7,4

7.3 Procedure 2: 1 GHz to 18 GHz

7.3.1 Antenna factors

Generally, the manufacturers of the LPDAs will supply figures for either the gain or antenna factor variation with frequency. Where the gain variation is given, this should be converted to antenna factor by the following formula:

$$\text{Antenna factor} = 20\log\left(\frac{9,734}{\lambda\sqrt{G}}\right) \text{ dB} \quad (6.6)$$

where:

λ is the wavelength (m);

G is the numeric gain.

NOTE: The gain figure to be used should be relative to an isotropic radiator - not relative to a dipole.

Whether directly or indirectly (by using this formula), the antenna factor columns in the results sheet headed "Transmit Antenna factor, AF_T " and "Receive Antenna factor, AF_R " should now be filled in with the relevant values.

7.3.2 Completion of the results sheet

The next stage is to fill in the column headed "Overall value". The relevant values are determined by subtracting the values in the "Site, V_{site} ", "Transmit Antenna factor, AF_T " and "Receive Antenna factor, AF_R " columns from the values in the "Direct, V_{direct} " column i.e.:

- "Overall value" = " V_{direct} " - " V_{site} " - " AF_T " - " AF_R "

The resulting value is the measured NSA for the anechoic chamber.

The final stages in determining the quality of the chamber are to complete the column headed "Ideal value" in the results sheet by taking the relevant values from table 12 and to calculate the entries for the "Difference" column from:

- "Difference" = "Overall value" - "Ideal value"

The resulting values in the "Difference" column represent the variation between the ideal and the measured performance of the anechoic chamber.

Table 11: Theoretical ideal values for NSA

Freq. (GHz)	Ideal NSA (dB)											
	Range length: 3 m Various positions						Range length: 10 m Various positions					
	1H 1V	2H 2V	3H 3V	4H, 4V 5H, 5V	6H, 6V 7H, 7V	8H, 8V 9H, 9V	1H 1V	2H 2V	3H 3V	4H, 4V 5H, 5V	6H, 6V 7H, 7V	8H, 8V 9H, 9V
1	-18,5	-20,8	-16,6	-18,2	-20,4	-16,5	-8,0	-8,6	-7,4	-8,0	-8,6	-7,4
1,25	-20,4	-22,7	-18,6	-20,0	-22,3	-18,4	-9,9	-10,6	-9,4	-9,9	-10,5	-9,3
1,5	-22,0	-24,3	-20,2	-21,7	-23,9	-20,0	-11,5	-12,2	-10,9	-11,5	-12,1	-10,9
1,75	-23,3	-25,6	-21,5	-23,1	-25,2	-21,3	-12,9	-13,5	-12,3	-12,8	-13,5	-12,3
2	-24,5	-26,8	-22,7	-24,2	-26,4	-22,5	-14,0	-14,7	-13,4	-14,0	-14,6	-13,4
2,25	-25,5	-27,8	-23,7	-25,3	-27,4	-23,5	-15,0	-15,7	-14,5	-15,0	-15,6	-14,4
2,5	-26,4	-28,7	-24,6	-26,2	-28,3	-24,4	-16,0	-16,6	-15,4	-15,9	-16,6	-15,4
2,75	-27,2	-29,6	-25,4	-27,0	-29,2	-25,3	-16,8	-17,4	-16,2	-16,8	-17,4	-16,2
3	-28,0	-30,3	-26,2	-27,8	-29,9	-26,0	-17,5	-18,2	-17,0	-17,5	-18,1	-16,9
3,25	-28,7	-31,0	-26,9	-28,5	-30,6	-26,7	-18,2	-18,9	-17,6	-18,2	-18,8	-17,6
3,5	-29,3	-31,6	-27,5	-29,1	-31,3	-27,4	-18,9	-19,5	-18,3	-18,9	-19,5	-18,3
3,75	-29,9	-32,2	-28,1	-29,7	-31,9	-28,0	-19,5	-20,1	-18,9	-19,5	-20,1	-18,9
4	-30,5	-32,8	-28,7	-30,3	-32,4	-28,5	-20,0	-20,7	-19,5	-20,0	-20,6	-19,4
4,5	-31,5	-33,8	-29,7	-31,3	-33,4	-29,5	-21,1	-21,7	-20,5	-21,0	-21,7	-20,5
5	-32,4	-34,7	-30,6	-32,2	-34,4	-30,5	-22,0	-22,6	-21,4	-22,0	-22,6	-21,4
5,5	-33,3	-35,6	-31,4	-33,0	-35,2	-31,3	-22,8	-23,4	-22,2	-22,8	-23,4	-22,2
6	-34,0	-36,3	-32,2	-33,8	-35,9	-32,0	-23,6	-24,2	-23,0	-23,5	-24,2	-23,0
6,5	-34,7	-37,0	-32,9	-34,5	-36,6	-32,7	-24,3	-24,9	-23,7	-24,3	-24,9	-23,7
7	-35,4	-37,7	-33,5	-35,1	-37,3	-33,4	-24,9	-25,5	-24,3	-24,9	-25,5	-24,3
7,5	-36,0	-38,3	-34,1	-35,7	-37,9	-34,0	-25,5	-26,1	-24,9	-25,5	-26,1	-24,9
8	-36,5	-38,8	-34,7	-36,3	-38,4	-34,5	-26,1	-26,7	-25,5	-26,0	-26,7	-25,5
8,5	-37,0	-39,4	-35,2	-36,8	-39,0	-35,1	-26,6	-27,2	-26,0	-26,6	-27,2	-26,0
9	-37,5	-39,8	-35,7	-37,3	-39,5	-35,6	-27,1	-27,7	-26,5	-27,1	-27,7	-26,5
9,5	-38,0	-40,3	-36,2	-37,8	-39,9	-36,0	-27,6	-28,2	-27,0	-27,5	-28,2	-26,9
10	-38,5	-40,8	-36,6	-38,2	-40,0	-36,5	-28,0	-28,6	-27,4	-28,0	-28,6	-27,4
10,5	-38,9	-41,2	-37,1	-38,7	-40,8	-36,9	-28,4	-29,1	-27,8	-28,4	-29,0	-27,8
11	-39,3	-41,6	-37,5	-39,1	-41,2	-37,3	-28,8	-29,5	-28,2	-28,8	-29,4	-28,2
11,5	-39,7	-42,0	-37,8	-39,4	-41,6	-37,7	-29,2	-29,8	-28,6	-29,2	-29,8	-28,6
12	-40,0	-42,3	-38,2	-39,8	-42,0	-38,1	-29,6	-30,2	-29,0	-29,6	-30,2	-29,0
12,5	-40,4	-42,7	-38,6	-40,2	-42,3	-38,4	-29,9	-30,6	-29,4	-30,0	-30,6	-29,3
13	-40,7	-43,0	-38,9	-40,5	-42,7	-38,8	-30,3	-30,9	-29,7	-30,4	-30,9	-29,7
13,5	-41,1	-43,4	-39,2	-40,8	-43,0	-39,1	-30,6	-31,2	-30,0	-30,7	-31,2	-30,0
14	-41,4	-43,7	-39,6	-41,1	-43,3	-39,4	-30,9	-31,5	-30,3	-31,0	-31,5	-30,3
14,5	-41,7	-44,0	-39,9	-41,5	-43,6	-39,7	-31,2	-31,9	-30,6	-31,3	-31,8	-30,6
15	-42,0	-44,3	-40,2	-41,7	-43,9	-40,0	-31,5	-32,1	-30,9	-31,6	-32,1	30,9
15,5	-42,3	-44,6	-40,4	-42,0	-44,2	-40,3	-31,8	-32,4	-31,2	-31,9	-32,4	-31,2
16	-42,5	-44,8	-40,7	-42,3	-44,5	-40,6	-32,1	-32,7	-31,5	-32,2	-32,7	-31,5
16,5	-42,8	-45,1	-41,0	-42,6	-44,7	-40,8	-32,3	-33,0	-31,8	-32,4	-33,0	-31,7
17	-43,1	-45,4	-41,2	-42,8	-45,0	-41,1	-32,6	-33,2	-32,0	-32,7	-33,2	-32,0
17,5	-43,3	-45,6	-41,5	-43,1	-45,3	-41,4	-32,9	-33,5	-32,3	-32,9	-33,5	-32,3
18	-43,6	-45,9	-41,7	-43,3	-45,5	-41,6	-33,1	-33,7	-32,5	-33,2	-33,7	-32,5

7.4 Procedure 3: 18 GHz to 26 GHz

7.4.1 Antenna factors

Generally, the manufacturers of the LPDAs will supply figures for either the gain or antenna factor variation with frequency. Where the gain variation is given, this should be converted to antenna factor by the following formula:

$$\text{Antenna factor} = 20\log\left(\frac{9,734}{\lambda\sqrt{G}}\right) \text{ dB} \quad (6.6)$$

where:

λ is the wavelength (m);

G is the numeric gain.

NOTE: The gain figure to be used should be relative to an isotropic radiator - not relative to a dipole.

Whether directly or indirectly (by using this formula), the antenna factor columns in the results sheet headed "Transmit Antenna factor, AF_T " and "Receive Antenna factor, AF_R " should now be filled in with the relevant values.

7.4.2 Completion of the results sheet

The next stage is to fill in the column headed "Overall value". The relevant values are determined by subtracting the values in the "Site, V_{site} ", "Transmit Antenna factor, AF_T " and "Receive Antenna factor, AF_R " columns from the values in the "Direct, V_{direct} " column i.e.:

- "Overall value" = " V_{direct} " - " V_{site} " - " AF_T " - " AF_R "

The resulting value is the measured NSA for the anechoic chamber.

The final stages in determining the quality of the chamber are to complete the column headed "Ideal value" in the results sheet by taking the relevant values from table 12 and to calculate the entries for the "Difference" column from:

- "Difference" = "Overall value" - "Ideal value"

The resulting values in the "Difference" column represent the variation between the ideal and the measured performance of the anechoic chamber.

Table 12: Theoretical ideal values for NSA

Ideal NSA (dB)												
Range length: 3 m Various positions							Range length: 10 m Various positions					
Freq. (GHz)	1H 1V	2H 2V	3H 3V	4H, 4V 5H, 5V	6H, 6V 7H, 7V	8H, 8V 9H, 9V	1H 1V	2H 2V	3H 3V	4H, 4V 5H, 5V	6H, 6V 7H, 7V	8H, 8V 9H, 9V
18	-43,6	-45,9	-41,7	-43,3	-45,5	-41,6	-33,1	-33,7	-32,5	-33,2	-33,7	-32,5
18,5	-43,8	-46,1	-42,0	-43,6	-45,7	-41,8	-33,3	-34,0	-32,8	-33,4	-34,0	-32,7
19	-44,0	-46,3	-42,2	-43,8	-46,0	-42,1	-33,6	-34,2	-33,0	-33,7	-34,2	-33,0
19,5	-44,3	-46,6	-42,4	-44,0	-46,2	-42,3	-33,8	-34,4	-33,2	-33,9	-34,4	-33,2
20	-44,5	-46,8	-42,7	-44,2	-46,4	-42,5	-34,0	-34,6	-33,4	-34,1	-34,6	-33,4
20,5	-44,7	-47,0	-42,9	-44,5	-46,6	-42,7	-34,2	-34,9	-33,7	-34,3	-34,9	-33,6
21	-44,9	-47,2	-43,1	-44,7	-46,8	-42,9	-34,4	-35,1	-33,9	-34,5	-35,1	-33,8
21,5	-45,1	-47,4	-43,3	-44,9	-47,0	-43,1	-34,6	-35,3	-34,1	-34,7	-35,3	-34,0
22	-45,3	-47,6	-43,5	-45,1	-47,2	-43,3	-34,8	-35,5	-34,3	-34,9	-35,5	-34,2
22,5	-45,5	-47,8	-43,7	-45,3	-47,4	-43,5	-35,0	-35,7	-34,5	-35,1	-35,7	-34,4
23	-45,7	-48,0	-43,9	-45,5	-47,6	-43,7	-35,2	-35,9	-34,6	-35,3	-35,8	-34,6
23,5	-45,9	-48,2	-44,1	-45,6	-47,8	-43,9	-35,4	-36,0	-34,8	-35,5	-36,0	-34,8
24	-46,1	-48,4	-44,2	-45,8	-48,0	-44,1	-35,6	-36,2	-35,0	-35,7	-36,2	-35,0
24,5	-46,2	-48,5	-44,4	-46,0	-48,2	-44,3	-35,8	-36,4	-35,2	-35,9	-36,4	-35,2
25	-46,4	-48,7	-44,6	-46,2	-48,4	-44,5	-36,0	-36,6	-35,4	-36,0	-36,6	-35,4
25,5	-46,6	-48,9	-44,8	-46,4	-48,5	-44,6	-36,1	-36,8	-35,5	-36,2	-36,7	-35,5
26	-46,8	-49,1	-44,9	-46,5	-48,7	-44,8	-36,3	-36,9	-35,7	-36,4	-36,9	-35,7

7.5 Procedure 4: 26 GHz to 40 GHz

7.5.1 Antenna factors

Generally, the manufacturers of the LPDAs will supply figures for either the gain or antenna factor variation with frequency. Where the gain variation is given, this should be converted to antenna factor by the following formula:

$$\text{Antenna factor} = 20 \log \left(\frac{9,734}{\lambda \sqrt{G}} \right) \text{ dB} \quad (6.6)$$

where:

λ is the wavelength (m);

G is the numeric gain.

NOTE: The gain figure to be used should be relative to an isotropic radiator - not relative to a dipole.

Whether directly or indirectly (by using this formula), the antenna factor columns in the results sheet headed "Transmit Antenna factor, AF_T " and "Receive Antenna factor, AF_R " should now be filled in with the relevant values.

7.5.2 Completion of the results sheet

The next stage is to fill in the column headed "Overall value". The relevant values are determined by subtracting the values in the "Site, V_{site} ", "Transmit Antenna factor, AF_T " and "Receive Antenna factor, AF_R " columns from the values in the "Direct, V_{direct} " column i.e.:

- "Overall value" = " V_{direct} " - " V_{site} " - " AF_T " - " AF_R "

The resulting value is the measured NSA for the anechoic chamber.

The final stages in determining the quality of the chamber are to complete the column headed "Ideal value" in the results sheet by taking the relevant values from table 12 and to calculate the entries for the "Difference" column from:

"Difference" = "Overall value" - "Ideal value"

The resulting values in the "Difference" column represent the variation between the ideal and the measured performance of the anechoic chamber.

Table 13: Theoretical ideal values for NSA

Ideal NSA (dB)												
Freq. (GHz)	Range length: 3 m Various positions						Range length: 10 m Various positions					
	1H 1V	2H 2V	3H 3V	4H, 4V 5H, 5V	6H, 6V 7H, 7V	8H, 8V 9H, 9V	1H 1V	2H 2V	3H 3V	4H, 4V 5H, 5V	6H, 6V 7H, 7V	8H, 8V 9H, 9V
26	-46,8	-49,1	-44,9	-46,5	-48,7	-44,8	-36,3	-36,9	-35,7	-36,4	-36,9	-35,7
26,5	-46,9	-49,2	-45,1	-46,7	-48,9	-45,0	-36,5	-37,1	-35,9	-36,5	-37,1	-35,9
27	-47,1	-49,4	-45,3	-46,9	-49,0	-45,1	-36,6	-37,3	-36,0	-36,7	-37,2	-36,0
27,5	-47,2	-49,6	-45,4	-47,0	-49,2	-45,3	-36,8	-37,4	-36,2	-36,9	-37,4	-36,2
28	-47,4	-49,7	-45,6	-47,2	-49,3	-45,4	-36,9	-37,6	-36,4	-37,0	-37,6	-36,3
28,5	-47,6	-49,9	-45,7	-47,3	-49,5	-45,6	-37,1	-37,7	-36,5	-37,2	-37,7	-36,5
29	-47,7	-50,0	-45,9	-47,5	-49,6	-45,7	-37,2	-37,9	-36,7	-37,3	-37,9	-36,6
29,5	-47,9	-50,2	-46,0	-47,6	-49,8	-45,9	-37,4	-38,0	-36,8	-37,5	-38,0	-36,79
30	-48,0	-50,3	-47,2	-47,8	-49,9	-46,0	-37,5	-38,2	-37,0	-37,6	-38,2	-36,9
30,5	-48,1	-50,5	-46,3	-47,9	-50,1	-46,2	-37,7	-38,3	-37,1	-37,8	-38,3	-37,1
31	-48,3	-50,6	-46,5	-48,1	-50,2	-46,3	-37,8	-38,5	-37,2	-37,9	-38,4	-37,2
31,5	-48,4	-50,7	-46,6	-48,2	-50,4	-46,5	-38,0	-38,6	-37,4	-38,0	-38,6	-37,4
32	-48,6	-50,9	-46,7	-48,3	-50,5	-46,6	-38,1	-38,7	-37,5	-38,2	-38,7	-37,5
32,5	-48,7	-51,0	-46,9	-48,5	-50,6	-46,7	-38,2	-38,9	-37,7	-38,3	-38,9	-37,6
33	-48,8	-51,1	-47,0	-48,6	-50,8	-46,9	-38,4	-39,0	-37,8	-38,4	-39,0	-37,8
33,5	-49,0	-51,3	-47,1	-48,7	-50,9	-47,0	-38,5	-39,1	-37,9	-38,6	-39,1	-37,9
34	-49,1	-51,4	-47,3	-48,9	-51,0	-47,1	-38,6	-39,3	-39,0	-38,7	-39,2	-38,0
34,5	-49,2	-51,5	-47,4	-49,0	-51,2	-47,3	-38,8	-39,4	-38,2	-38,8	-39,4	-38,2
35	-49,3	-51,6	-47,5	-49,1	-51,3	-47,4	-38,9	-39,5	-38,3	-39,0	-39,5	-38,3
35,5	-49,5	-51,8	-47,6	-49,2	-51,4	-47,5	-39,0	-39,6	-38,4	-39,1	-39,6	-38,4
36	-49,6	-51,9	-47,8	-49,4	-51,5	-47,6	-39,1	-39,8	-38,5	-39,2	-39,7	-38,5
36,5	-49,7	-52,0	-47,9	-49,5	-51,6	-47,7	-39,2	-39,9	-38,7	-39,3	-39,9	-38,6
37	-48,8	-52,1	-48,0	-49,6	-51,8	-47,9	-39,4	-40,0	-38,8	-39,4	-40,0	-38,8
37,5	-49,9	-52,2	-48,1	-49,7	-51,9	-48,0	-39,5	-40,1	-38,9	-39,6	-40,1	-38,9
38	-50,1	-52,4	-48,2	-49,8	-52,0	-48,1	-39,6	-40,2	-39,0	-39,7	-40,2	-39,0
38,5	-50,2	-52,5	-48,3	-49,9	-52,1	-48,2	-39,7	-40,3	-39,1	-39,8	-40,3	-39,1
39	-50,3	-52,6	-48,5	-50,0	-52,2	-48,3	-39,8	-40,4	-39,2	-39,9	-40,4	-39,2
39,5	-50,4	-52,7	-48,6	-50,2	-52,3	-48,4	-39,9	-40,6	-39,3	-40,0	-40,5	-39,3
40	-50,5	-52,8	-48,7	-50,3	-52,4	-48,5	-40,0	-40,7	-39,5	-40,1	-40,7	-39,4

8 Report format

It is suggested that the results of the verification are presented in two ways, firstly in the format of a completed results sheet, and secondly in the form of a plot of the "Difference" column against frequency for each polarization as shown in figure 17.

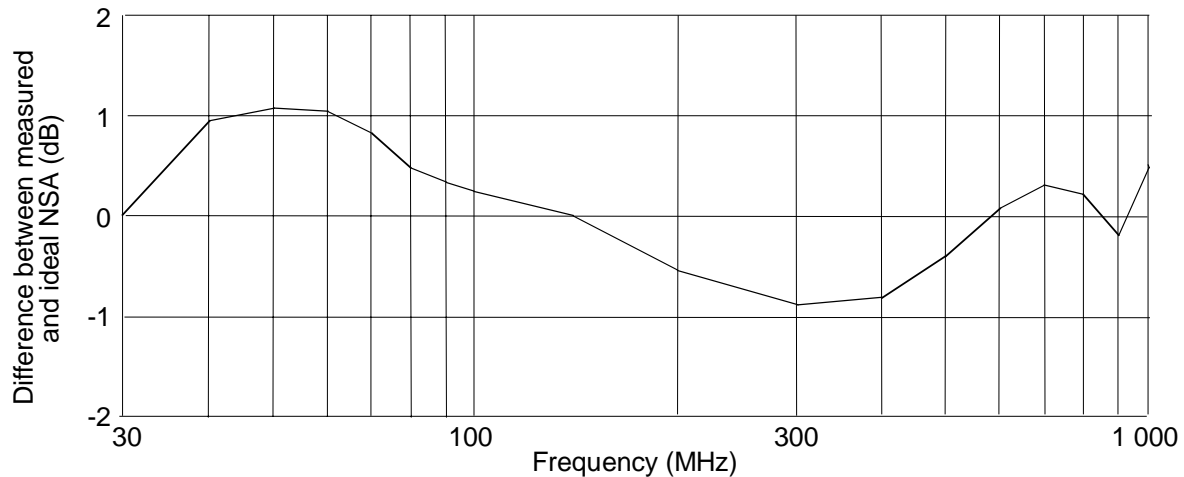

Figure 17: Example plot of the difference between the measured and ideal NSA against frequency

9 Evaluation of uncertainty contributions specific to an anechoic chamber

A typical anechoic chamber comprises two main components:

- a metallic shield;
- radio absorbing material.

Whilst each component is included to improve the quality of the testing environment within the chamber, each has negative effects as well. In the following clause some positive effects are mentioned as a brief introduction to a discussion of the negative effects and their impact on measurement uncertainty.

9.1 Effects of the metal shielding

The benefits of shielding a testing area can be seen by considering the situation on a typical Open Area Test Site where ambient RF interference can add considerable uncertainty to the measurements. Such RF ambient signals can be continuous sources e.g. commercial radio and television, link services, navigation etc. or intermittent ones e.g. CB, emergency services, DECT, GSM, paging systems, machinery and a variety of others. The interference can be either narrowband or broadband.

The anechoic chamber overcomes these problems by the provision of a shielded enclosure. A shielded enclosure is defined as any structure that protects its interior from the effects of an exterior electric or magnetic field, or conversely, protects the surrounding environment from the effects of an interior field. The shielding is normally provided by metal panels with continuous electrical contact between them and any opening provided in the shield (e.g. doors and breakout panels).

Further advantages of the shield are protection from the weather and the general degradation effects it can have.

9.1.1 Resonances

Any metal shield will act as a reflecting surface and grouping six of them together to form a metal box makes it possible for the chamber to act like a resonant waveguide cavity. Whilst these resonance effects tend to be narrowband, their peak magnitudes can be high, resulting in a significant disruption of the desired field distribution.

A resonant waveguide cavity mode can, in theory, be excited at any frequency which satisfies the following formula:

$$f = 150 \sqrt{\left(\frac{x}{l}\right)^2 + \left(\frac{y}{b}\right)^2 + \left(\frac{z}{h}\right)^2} \text{ MHz} \quad (5.1)$$

where l , b and h are respectively the length, breadth and height of the chamber in metres and x , y and z are mode numbers of which only one is allowed to be zero at any time. As an example, the lowest frequency at which a resonance could occur in a facility which measures 5 m by 5 m by 7 m is 36,87 MHz.

Caution should be exercised whenever measurements are attempted close to any frequencies predicted by this formula, particularly for the lowest values, for which the absorber might offer poor performance. To improve confidence in the chamber, these lower calculated frequencies could be included in the verification procedure.

9.1.2 Imaging of antennas

The shield will have a significant impact on the overall performance of the chamber if it is not adequately "masked" from the test volume by the absorbing material i.e. if the absorbing material has inadequate absorption characteristics.

For example, in the extreme case of 0 dB return loss from the absorbing materials (i.e. zero absorption/perfect reflection) an antenna will "see" an image of itself in the end wall close behind, the two side walls, the ceiling, the floor and, to a lesser extent, the far end wall (see figure 2).

In this multi-image environment, the one driven (real) antenna is, in effect, powering a seven element array (of which it is one). Major changes result to all of the antenna's electrical characteristics such as input impedance, gain and radiation pattern.

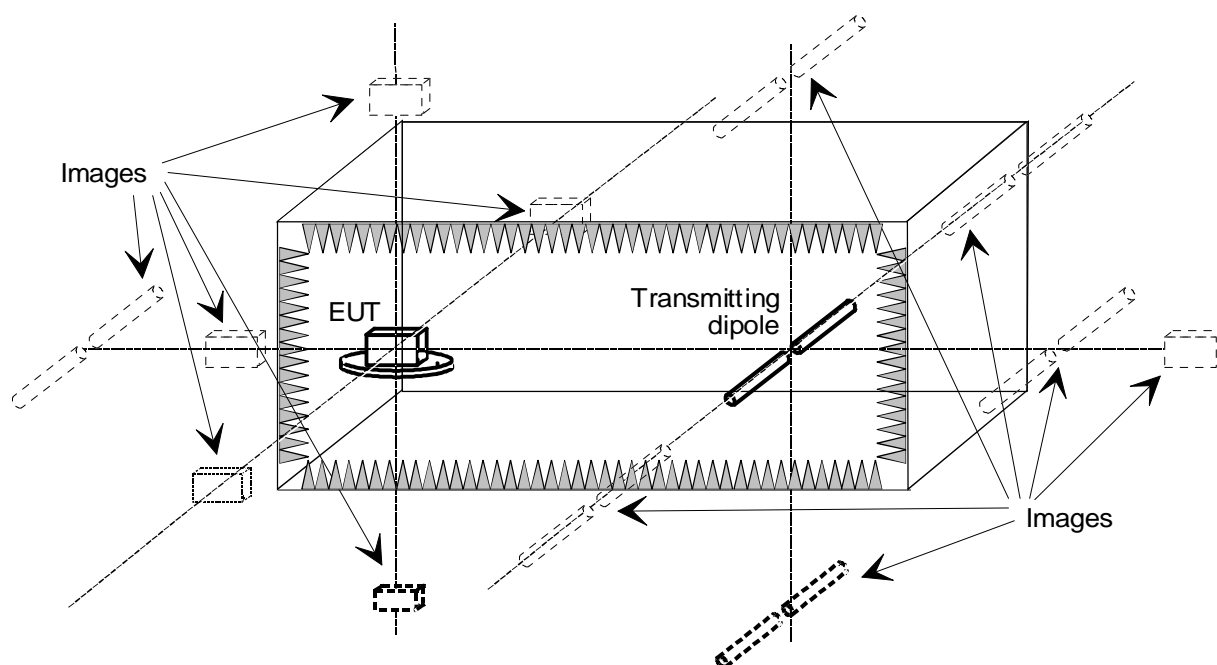

Figure 18: Imaging in the shielded enclosure

Whilst no chamber would be used at any frequency for which the absorbing material performs so badly as to appear "invisible", this example illustrates that any finite value of reflectivity will produce this imaging to some extent.

Good absorption (low reflectivity) will minimize all internal reflections, whereas poor absorption (high reflectivity) will not only produce imaging of the antennas (or the EUT), but can also contribute numerous high amplitude reflections.

9.2 Effects of the radio absorbing materials

9.2.1 Introduction

As discussed in clause 5.1.2 the absorbing material plays a critical role in the chamber's performance. Absorption is the irreversible conversion of the energy of an electromagnetic wave into another form of energy as a result of wave interaction with matter (i.e. it gets hot). The efficiency with which the material absorbs energy is determined by the absorption coefficient. This is defined as the ratio of the energy absorbed by the surface to the energy incident upon it. It is more usual; however, for the reflectivity (i.e. return loss) of an absorbing material to be quoted rather than its absorption, the assumption being that any incident power not reflected is absorbed.

Different types of RF absorbers are available (see figure 3). They all absorb radiated energy to a greater or lesser extent, but possess different mechanical and electrical properties making certain types more suitable for some applications than others.

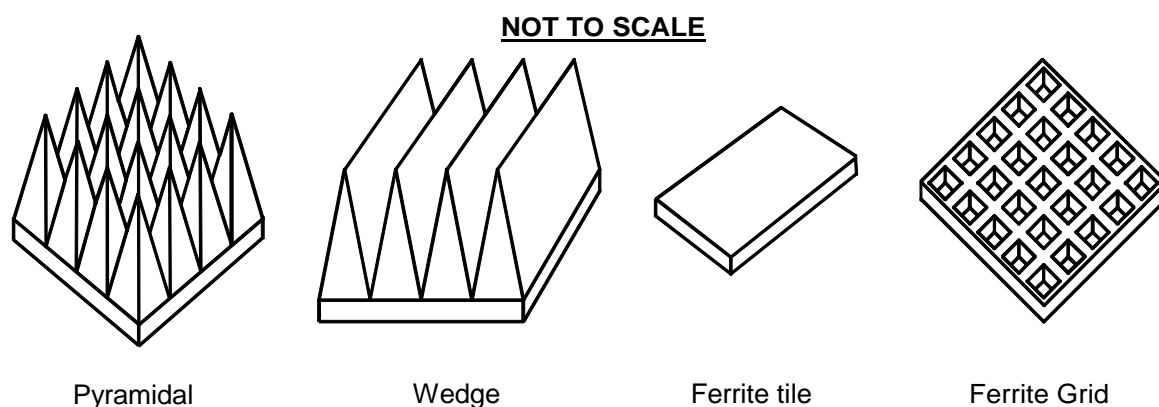

Figure 19: Typical RF absorbers

9.2.2 Pyramidal absorbers

This type of absorber is manufactured from polyurethane foam impregnated with carbon, and moulded into a pyramidal shape (see figure 3). This shape provides inherently wide bandwidth, small polarization dependence and gives reasonably wide angular coverage.

Pyramidal absorbers behave as lossy, tapered transitions, ranging from low impedance at the base to 377Ω at the tip (to match the impedance of free space). They work on the principle that if all of the energy is converted to heat before the base is reached; there is nothing to reflect from the shield.

9.2.3 Wedge absorbers

Wedge absorbers (see figure 3), are a variation of the polyurethane pyramidal foam type, which tends to overcome the degradation of reflectivity with increasing angle of incidence, but at some performance cost.

This improvement is only for cases where the incident wave direction is parallel to the ridge of the wedge as no broadside presents itself at off normal angles as is the case with pyramidal absorbers.

Disadvantages of this type of absorber are degraded performance compared to pyramidal types at normal incidence and when used with the ridge perpendicular to the incident wave.

These effects make wedge absorbers more suitable for use in chambers with range lengths of 10 m or more where they are used to good advantage in the middle sections of the ceilings, floor and side walls.

9.2.4 Ferrite tiles

Ferrite is a ferromagnetic ceramic material. Its susceptibility and permeability is dependant on the field strength and magnetization curves (which have hysteresis). Its magnetic characteristics can be affected by pressure, temperature, field strength, frequency and time. Its mechanical and electromagnetic characteristics depend heavily on the sintering process used to form the ferrite. It is hard (physically), brittle (as are all ceramics) and will chip and break if handled roughly.

Ferrite tiles are thin, flat, ceramic blocks typically 15 cm by 8 cm by 1 cm thick (see figure 3). Both thickness and composition of the ferrite material affect their absorption performance.

In practice, their layout is also very critical as small air gaps between adjacent tiles can considerably degrade performance at the lowest frequencies (30 MHz to 100 MHz). However, when properly installed this is the frequency range for which they give the most benefit over pyramidal foam absorbers.

Their main advantages are that they are thin (typically 1 cm) so the shielded enclosure outside dimensions are relatively small compared to pyramidal foam for the same internal volume (see table 1). Ferrite tiles also have a durable surface and have stable performance with time.

Disadvantages are cost, the strong dependence of the reflectivity performance on both polarization and angle of incidence and possible non linear performance due to saturation at high field strengths.

Due to their relatively high cost ferrite tiles are mainly built up into 1 m or 2 m square blocks which are placed strategically in the chamber under pyramidal foam absorbers in the middle sections of the side walls, floor and ceiling, the main reflection paths between antennas (or between an antenna and EUT). They are also used on the end walls to improve absorption and to reduce image coupling.

This combination of ferrite tiles and pyramidal foam absorbers is more cost effective in performance terms than a fully ferrited room.

9.2.5 Ferrite grids

Ferrite grids are typically 10 cm by 10 cm by 2,5 cm thick. They provide absorption from 30 MHz to 40 000 MHz. The grid structure provides better power handling characteristics and avoids the installation problems associated with plain tiles. Their absorption characteristics are basically the same as for ferrite tiles (see figure 6).

9.2.6 Urethane/ferrite hybrids

Urethane/ferrite hybrid absorbers consist of pyramidal foam absorber bonded to a ferrite tile backing. They are designed in such a way that the ferrite tiles are active at the low frequencies, where the pyramidal foam absorbers are not very efficient, whilst the pyramidal absorbers take over at higher frequencies.

A disadvantage is the impedance mismatch between the ferrite base and the foam pyramids which results in performance degradation in some frequency ranges.

In a similar manner to the ferrite tile, the hybrid absorber is used in the middle sections of the side walls floor and ceilings - the main reflection paths between antennas (or between an antenna and EUT). They are also used on the end walls to improve absorption and to reduce image coupling.

9.2.7 Floor absorbers

Anechoic materials (except ferrite tiles and grids) cannot, in general, support loads. Normally, therefore, a false floor of RF transparent material is built above the anechoic materials, to enable access to the test antenna and turntable. It is, however, very difficult to obtain a floor that is truly RF transparent and the floor is often "visible". This tends to be revealed when the performance of the chamber is being verified and has been known to lead to constructional modifications.

Special types of floor absorbers can be used. These are constructed of normal pyramidal absorbers whose external profiled sections have been filled with a low-loss rigid foam so as to form a solid block. This is usually capable of supporting the weight of a man, but with usage, degradation in performance occurs.

The most common solution is not to have a floor for access, but to arrange access to the antenna support, either with another access door (degrades chamber performance) or by making the antenna mount such that it can be easily moved to the turntable end to facilitate antenna changes, etc.

9.2.8 Reflection in an anechoic chamber

As has been stated, the absorbing materials used and their layout play a critical role in the chamber's performance. A plan view of an anechoic chamber with its end and side walls covered in pyramidal foam absorbers is shown in figure 8. Mounted in the chamber are two dipoles (shown for illustration purposes only, although this is a common arrangement found in test methods and the verification procedure). Various single and double bounce reflection paths are also illustrated.

The single bounce reflection paths via the end walls are at normal incidence to the absorbers, and since the absorbers are at maximum efficiency at normal incidence the reflections are of a low amplitude. However the amplitude of the worst case reflections, the single bounce paths between the antennas via the side walls, are dependant on the angles of incidence, which themselves are dependant on the geometry (cross section and range length) of the chamber. The ceiling and floor provides other single bounce reflection paths.

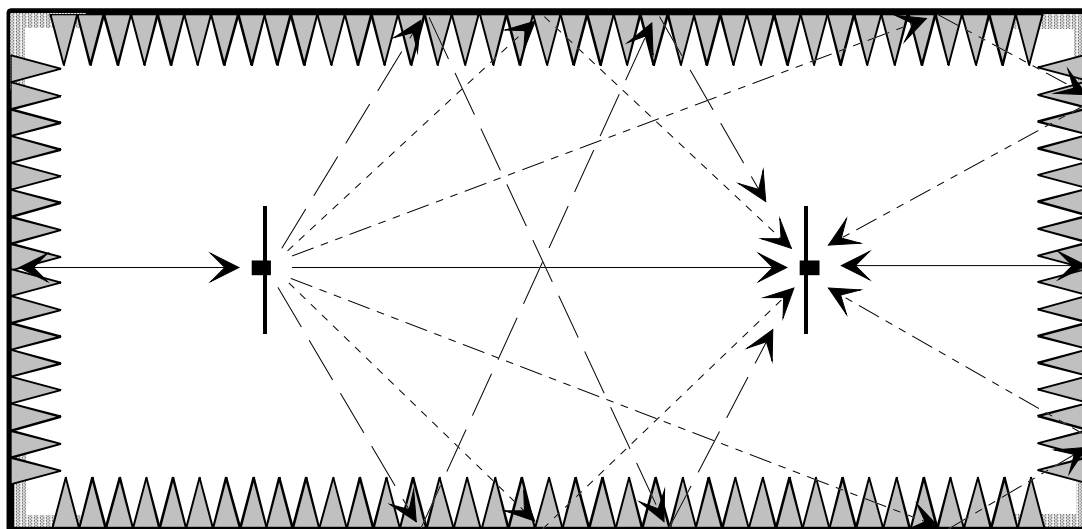

Figure 20: Plan view of an anechoic chamber that uses pyramidal absorber

The direct path between the antennas is the only wanted signal and all other signals, whether the result of reflections from the absorber or from extraneous sources (see clause 5.3.1) interfere with the required field and result in measurement uncertainty. The situation is further complicated by the directional nature of the dipoles, reflections in the E-plane of the dipole being reduced in amplitude when compared to the case for the orthogonal polarization, as a result of the dipole's radiation pattern.

For optimized chamber performance the middle sections of the ceiling, floor and side walls should be carefully constructed to provide the highest values of absorption in the chamber, especially for range lengths greater than 3 m. From a measurement viewpoint the amount of reflection from the walls has a direct effect on the "quality" of the measurement.

Experience has shown that in chambers which have 0,66 m pyramidal absorbers the overall performance has three distinct stages:

- below about 150 MHz or so the amplitude of reflections from the walls, floor and ceiling can be observed to degrade the operation of the facility. The shielded enclosure may act as a large cavity resonator, although all possible modes may not be excited as they are dependant on the configurations of the test equipment and EUT;
- from about 150 MHz up to a few hundred MHz most of the components (e.g. absorber dimensions) return to full specification and the chamber tends to "behave" quite well;

- at very high frequencies, arbitrarily hundreds of MHz to well above 1 000 MHz resonances can be set up by the physical dimensions of the absorber material which can negate the fact that the absorber materials themselves have good performance characteristics at these frequencies.

In the present document, the uncertainty contribution due to reflectivity of the absorbers is estimated in TR 102 273-1-1 [6], annex A and given a representative symbol as follows:

u_{j03} is used for the contribution associated with the reflectivity of the absorbing material between the transmitting antenna and the receiving antenna in verification procedures.

9.2.9 Mutual coupling due to imaging in the absorbing material

Mutual coupling is the mechanism which produces changes in the electrical behaviour of an antenna when placed close to a conducting surface, another antenna, etc. The changes can include, amongst others, de-tuning, gain variation and changes to the radiation pattern. Whilst the absorbing material helps to reduce these effects, it does not remove them completely. To avoid the major effects of any such performance changes, it is a stipulation in all tests, that no part of any antenna, shall at any time, approach to within less than 1 m of any absorbing material. Where this condition cannot be satisfied, testing shall not be carried out.

The magnitude of the effects on the electrical characteristics due to the degree of imaging in the absorber/shield of the anechoic chamber are estimated in TR 102 273-1-1 [6], annex A, and the uncertainty contributions due to the mutual coupling effects to the absorber materials are given a representative symbol as follows:

u_{j07} is used for the uncertainty contribution associated with the transmitting or receiving antenna and its images in the absorbing material in verification procedures.

9.3 Other effects

9.3.1 Extraneous reflections

Within the chamber, reflecting objects such as internal lighting, cameras and safety circuits (which are normally used in chambers where high power fields are generated) should be avoided (or their effects minimized) as they will have a direct effect on the quality of the measurement at that site. Similarly, the materials from which the antenna mount and turntable are constructed should be of low relative dielectric constant.

9.3.2 Mutual coupling between antennas (or antenna and EUT)

Mutual coupling, as stated in clause 5.2.9, is the mechanism which produces changes in the electrical behaviour of an EUT (or antenna) when placed close to a conducting surface, another antenna, etc. The changes can include detuning, gain variation and distortion of the radiation pattern.

The magnitude of the effects on the electrical characteristics of the EUT (or antenna) due to the mutual coupling between them are estimated in TR 102 273-1-1 [6] annex A and the uncertainty contribution which result is given a representative symbol as follows:

u_{j10} is used for the uncertainty contribution associated with the mutual coupling between transmitting antenna and receiving antenna in verification procedures.

9.3.3 Turntable and antenna mounting fixtures

As the turntable and mounting fixtures are in close proximity to the antenna they can significantly change its performance. The antenna mount, turntable and mounting fixtures should, therefore, be constructed from non-conducting, low relative dielectric constant plastics or wood to reduce reflections and interactions. It is recommended that materials with dielectric constants of less than 1,5 be used for all supporting structures.

Structurally, the antenna mount should be sufficiently strong to prevent twisting under load, since the antenna pattern may move "off axis" with the result that the signal level may not be maximized (see figure 21).

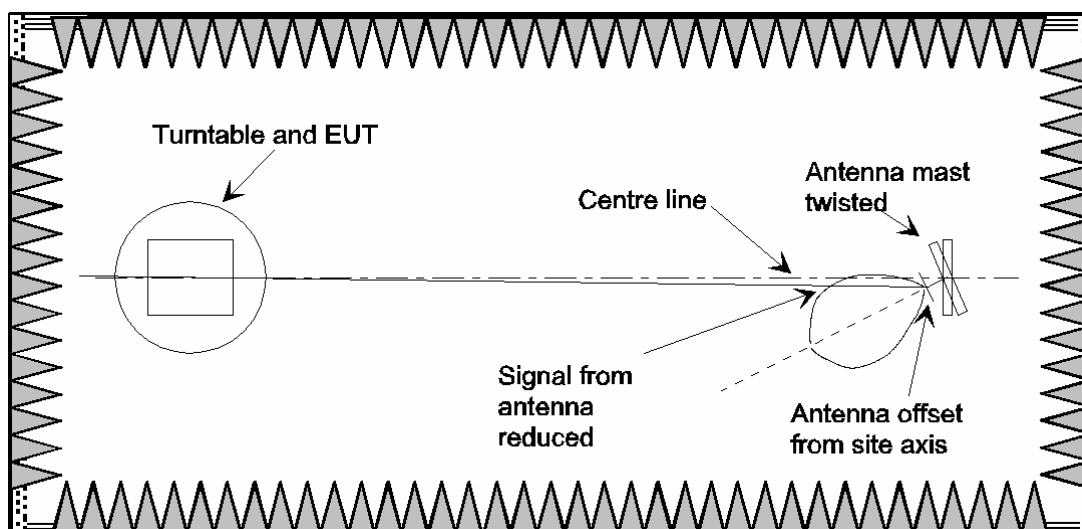

Figure 21: Signal reduction due to a twisted mast (plan view)

9.3.4 Antenna cabling

There are radiating mechanisms by which RF cables can introduce uncertainties into radiated measurements:

- leakage;
- acting as a parasitic element to the antenna;
- introducing common mode current to the balun of the antenna.

Leakage allows electromagnetic coupling into the cables. Because the electromagnetic wave contains both electric and magnetic fields, mixed coupling can occur and the voltage induced is very dependant on the orientation, with respect to the cable, of the fields. This coupling can have different effects depending on the length of the cable and where it is in the system. Cables are usually the longest part of the test equipment configuration and, as such, leakage can make them act as efficient receiving or transmitting antennas thereby contributing significantly to the uncertainty of a measurement.

The parasitic effect of the cable can potentially be the most significant of the three effects and can cause major changes to the antenna's radiation pattern, gain and input impedance. The common mode current problem has similar effects on the antenna's performance.

All three effects can be largely eliminated by routeing and loading the cables with ferrite beads as detailed in the test methods. A cable for which no precautions have been taken to prevent these effects can cause different results to be obtained simply by being repositioned.

u_{j19} is used for the uncertainty contribution associated with cable factor (the combined uncertainty which results from interaction between any antenna and its cable).

9.3.5 Positioning of the antennas

The phase centre of an antenna is the point within the antenna from which it radiates. If the antenna was rotated about this point, the phase of the received/transmitted signal would not change. For validation procedures it is vital to be able to identify the phase centre.

The phase centre of an antenna is the point from which it can be considered to radiate. If the antenna was rotated about this point, the phase of the received/transmitted signal would not change. The phase centre of both a dipole and biconic antenna is in the centre of its two arms, for a Log Periodic Dipole Antenna (LPDA) it should be assumed to be halfway along its longitudinal axis and for a waveguide horn it is the centre of its open mouth.

u_{j22} is used for the uncertainty contribution associated with the positioning of the phase centre of the receiving and transmitting antenna.

Certain antennas, most notably the LPDA, possess a phase centre which is difficult to pinpoint at any particular frequency. Further, for this type of antenna the phase centre moves along the array with changing frequency resulting in a measurement distance uncertainty (e.g. an LPDA with a 0,3 m length contributes a standard uncertainty level due to range length uncertainty of $u_j = 1,0$ dB). To use such an antenna for site verification, for example, could introduce large uncertainties.

u_{j23} is used for the uncertainty contribution associated with not knowing the exact position of the phase centre for LPDAs.

10 Calculation of measurement uncertainty (Procedure 1)

The column headed "Overall" in the results sheet is completed during the processing of the results for the verification procedure. The values entered in this column are the measured NSA figures for the anechoic chamber.

The value, at any particular frequency, for the measured NSA is "Direct" (reference value) less "Site" (the value appearing on the receiver during the measurement) less the sum of "Transmit Antenna factor AF_T ", "Receive Antenna factor AF_R " and "Mutual coupling correction AF_{TOT} " i.e.:

- NSA = "Direct" - "Site" - "Transmit Antenna factor" - "Receive Antenna factor" - "Mutual coupling correction"

As an example, let the direct attenuation be +10 dBm and the received level during the site measurement be -33 dBm. Putting both the antenna factors at 3,9 dB and the mutual coupling correction at 2,1 dB gives a measured NSA value of:

- NSA = (10 dBm - (-33 dBm)) - (3,9 dB + 3,9 dB + 2,1 dB) = 33,1 dB

There are uncertainties in each of these components for the NSA and an example of a typical calculation of the expanded uncertainty is now given. A fully worked example calculation can be found in clause 4 of TR 102 273-1-2 [7].

10.1 Uncertainty contribution, direct attenuation measurement

The verification procedure involves two different measurement stages and the derivation of NSA. The first stage (the reference) is with all the items of test equipment connected directly together via an adapter between the attenuators as shown in figure 22 (components shown shaded are common to both stages of the procedure).

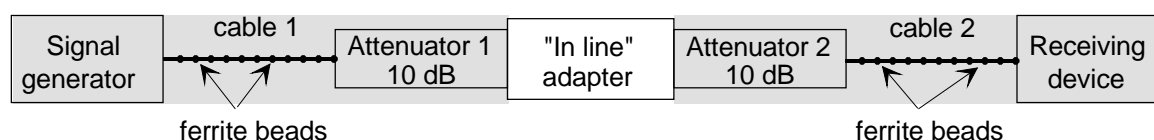

Figure 22: Stage 1: Direct attenuation measurement for the verification procedure

Despite the commonality of most of the components to both stages of this procedure, the mismatch uncertainty contribution from both stages has to be calculated and included in the uncertainty calculations, since the load conditions vary i.e. antennas replace the adapter in the second stage. Conversely, as a result of this commonality, the uncertainty contribution of some of the individual components will cancel.

The magnitude of the random uncertainty contribution to this stage of the procedure can be assessed from multiple repetition of the direct attenuation measurement. All the uncertainty components which contribute to this stage of the test are listed in table 13. Annex A should be consulted for the sources and/or magnitudes of the uncertainty contributions.

Table 14: Contributions from the direct attenuation measurement

$u_{j \text{ or } i}$	Description of uncertainty contributions	dB
$u_{\beta 5}$	mismatch: direct attenuation measurement	
$u_{\beta 8}$	signal generator: absolute output level	
$u_{\beta 9}$	signal generator: output level stability	
$u_{j 19}$	cable factor: receiving antenna	0,00
$u_{j 19}$	cable factor: transmitting antenna	0,00
$u_{j 41}$	insertion loss: receiving antenna cable	0,00
$u_{j 41}$	insertion loss: transmitting antenna cable	0,00
$u_{j 40}$	insertion loss: receiving antenna attenuator	0,00
$u_{j 40}$	insertion loss: transmitting antenna attenuator	0,00
$u_{j 42}$	insertion loss: adapter	
$u_{j 47}$	receiving device: absolute level	0,00
$u_{j 48}$	receiving device: linearity	0,00
$u_{j 01}$	random uncertainty (see note in clause A.18 of TR 102 273-1-2 [7] and note in clause 6.4.7 of TR 102 273-1-1 [6])	

The standard uncertainties from table 13 should be combined by RSS in accordance with clause 5 of TR 102 273-1-1 [6]. This gives the combined standard uncertainty ($u_{c \text{ direct attenuation measurement}}$) for the direct attenuation measurement in dB.

10.2 Uncertainty contribution, NSA measurement

This stage involves removing the adapter and connecting each attenuator to an antenna as shown in figure 23, and recording the new level on the receiving device.

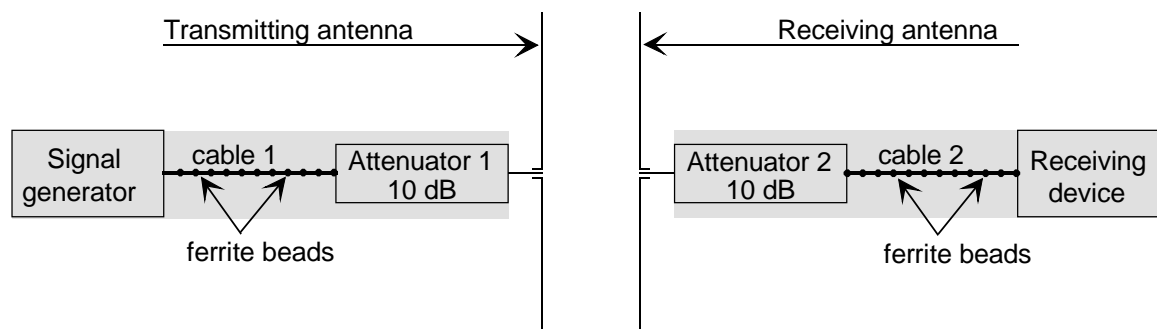

Figure 23: Stage 2: NSA measurement

The difference in received levels (after allowance for any correction factors which may be appropriate) for the same signal generator output level, reveals the NSA. All the uncertainty components which contribute to this stage of the test are listed in table 14. Annex A should be consulted for the sources and/or magnitudes of the uncertainty contributions.

Table 15: Contributions from the NSA measurement

<i>u_j</i> or <i>i</i>	Description of uncertainty contributions	dB
<i>u_{j36}</i>	mismatch: transmitting part	
<i>u_{j37}</i>	mismatch: receiving part	
<i>u_{j38}</i>	signal generator: absolute output level	
<i>u_{j39}</i>	signal generator: output level stability	
<i>u_{j19}</i>	cable factor: receiving antenna	
<i>u_{j19}</i>	cable factor: transmitting antenna	
<i>u_{j41}</i>	insertion loss: receiving antenna cable	0,00
<i>u_{j41}</i>	insertion loss: transmitting antenna cable	0,00
<i>u_{j40}</i>	insertion loss: receiving antenna attenuator	0,00
<i>u_{j40}</i>	insertion loss: transmitting antenna attenuator	0,00
<i>u_{j47}</i>	receiving device: absolute level	
<i>u_{j48}</i>	receiving device: linearity	
<i>u_{j16}</i>	range length	
<i>u_{j03}</i>	reflectivity of absorber material: transmitting antenna to the receiving antenna	
<i>u_{j44}</i>	antenna: antenna factor of the receiving antenna	
<i>u_{j44}</i>	antenna: antenna factor of the transmitting antenna	
<i>u_{j46}</i>	antenna: tuning of the receiving antenna	
<i>u_{j46}</i>	antenna: tuning of the transmitting antenna	
<i>u_{j22}</i>	position of the phase centre: receiving antenna	
<i>u_{j22}</i>	position of the phase centre: transmitting antenna	
<i>u_{j07}</i>	mutual coupling: transmitting antenna to its images in the absorbing material	
<i>u_{j07}</i>	mutual coupling: receiving antenna to its images in the absorbing material	
<i>u_{j10}</i>	mutual coupling: transmitting antenna to the receiving antenna	
<i>u_{j12}</i>	mutual coupling: interpolation of mutual coupling and mismatch loss correction factors	
<i>u_{j34}</i>	ambient effect	
<i>u₀₁</i>	random uncertainty (see note in clause A.18 of TR 102 273-1-2 [7] and note in clause 6.4.7 of TR 102 273-1-1 [6])	

The standard uncertainties from table 14 should be combined by RSS in accordance with clause 5 of TR 102 273-1-1 [6]. This gives the combined standard uncertainty (u_c NSA measurement) for the NSA measurement in dB.

10.3 Expanded uncertainty of the verification procedure

The combined standard uncertainty of the results of the verification procedure is the combination of the components outlined in clauses 6.6.1 and 6.6.2. The components to be combined are: u_c direct attenuation measurement and u_c NSA measurement

$$u_c = \sqrt{u_{c \text{ direct attenuation measurement}}^2 + u_{c \text{ NSA measurement}}^2} = _, _ \text{ dB} \quad (6.7)$$

The expanded uncertainty is $\pm 1,96 \times u_c = \pm _, _ \text{ dB}$ at a 95 % confidence level.

11 Calculation of measurement uncertainty (Procedure 2)

The column headed "Overall" in the results sheet is completed during the processing of the results for the verification procedure. The values entered in this column are the measured NSA figures for the anechoic chamber.

The value, at any particular frequency, for the measured NSA is "Direct" (reference value) less "Site" (the value appearing on the receiver during the NSA measurement) less the sum of "Transmit Antenna factor AF_T " and "Receive Antenna factor AF_R " i.e.:

- $NSA = \text{"Direct"} - \text{"Site"} - \text{"Transmit Antenna factor"} - \text{"Receive Antenna factor"} \quad (6.8)$

As an example, let the direct attenuation value be 10 dBm and the received level during the site measurement be -33 dBm. Putting each antenna factor at 3,9 dB gives a measured NSA value of:

- $NSA = [10 \text{ dBm} - (-33 \text{ dBm})] - (7,8 \text{ dB}) = 35,2 \text{ dB} \quad (6.9)$

There are uncertainties in each of these components for the NSA and an example of a typical calculation of the expanded uncertainty is now given. A fully worked example calculation can be found in clause 4 of TR 102 273-1-2 [7].

11.1 Uncertainty contribution, direct attenuation measurement

The verification procedure involves two different measurement stages and the derivation of NSA. The first stage (the reference) is with all the items of test equipment connected directly together via an adapter between the attenuators as shown in figure 23 (components shown shaded are common to both stages of the procedure).

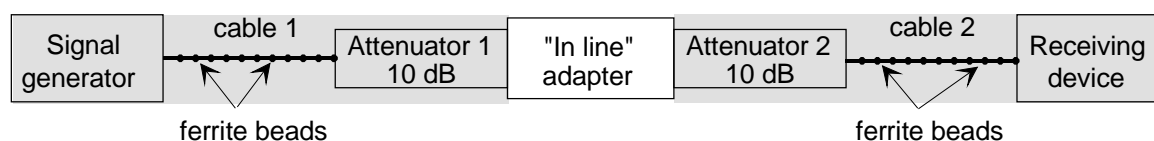

Figure 23: Stage 1: Direct attenuation measurement for the verification procedure

Despite the commonality of most of the components to both stages of this procedure, the mismatch uncertainty contribution for both stages of the test has to be calculated and included in the uncertainty calculations. This is the result of load conditions varying (i.e. antennas replacing the adapter in the second stage). Conversely, as a result of this commonality, the uncertainty contributions of some of the individual components will cancel.

The magnitude of the random uncertainty contribution to each stage of the procedure can be assessed from multiple repetitions of the respective measurements. All the uncertainty components which contribute to this stage of the test are listed in table 15. Annex A should be consulted for the sources and/or magnitudes of the uncertainty contributions.

Table 16: Contributions from the direct attenuation measurement

<i>u_j</i> or <i>i</i>	Description of uncertainty contributions	dB
<i>u_{j35}</i>	mismatch: direct attenuation measurement	
<i>u_{j38}</i>	signal generator: absolute output level	0,00
<i>u_{j39}</i>	signal generator: output level stability	
<i>u_{j19}</i>	cable factor: receiving LPDA	0,00
<i>u_{j19}</i>	cable factor: transmitting LPDA	0,00
<i>u_{j41}</i>	insertion loss: receiving LPDA cable	0,00
<i>u_{j41}</i>	insertion loss: transmitting LPDA cable	0,00
<i>u_{j40}</i>	insertion loss: receiving LPDA attenuator	0,00
<i>u_{j40}</i>	insertion loss: transmitting LPDA attenuator	0,00
<i>u_{j42}</i>	insertion loss: adapter	
<i>u_{j47}</i>	receiving device: absolute level	0,00
<i>u_{j48}</i>	receiving device: linearity	0,00
<i>u_{D01}</i>	random uncertainty (see note in clause A.18 of TR 102 273-1-2 [7] and note in clause 6.4.7 of TR 102 273-1-1 [6])	

The standard uncertainties from table 15 should be combined by RSS in accordance with clause 5 of TR 102 273-1-1 [6]. This gives the combined standard uncertainty (u_c direct attenuation measurement) for the direct attenuation measurement in dB.

11.2 Uncertainty contribution, NSA measurement

This stage involves removing the adapter and connecting each attenuator to an antenna as shown in figure 24, and recording the new level on the receiving device.

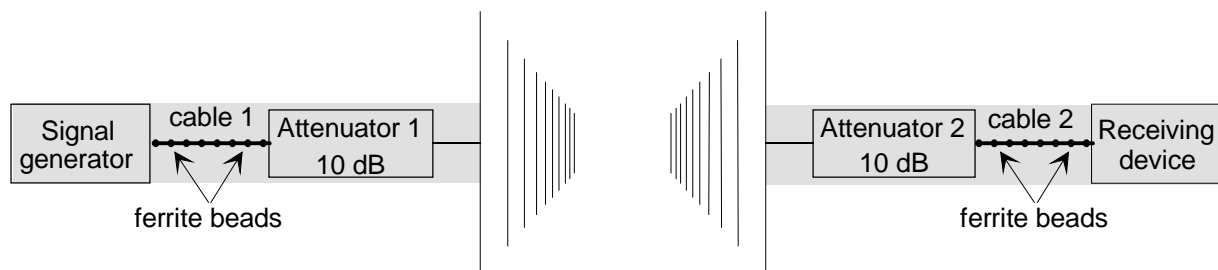
**Figure 24: Stage 2: NSA measurement**

The difference in received levels (after allowance for any correction factors which may be appropriate), for the same signal generator output level, reveals the NSA. All the components which contribute to this stage of the test are listed in table 16. Annex A should be consulted for the sources and/or magnitudes of the uncertainty contributions.

Table 17: Contributions from the measurement

<i>uj</i> or <i>l</i>	Description of uncertainty contributions	dB
u_{j36}	mismatch: transmitting part	
u_{j37}	mismatch: receiving part	
u_{j38}	signal generator: absolute output level	0,00
u_{j39}	signal generator: output level stability	
u_{j19}	cable factor: receiving LPDA	
u_{j19}	cable factor: transmitting LPDA	
u_{j41}	insertion loss: receiving LPDA cable	0,00
u_{j41}	insertion loss: transmitting LPDA cable	0,00
u_{j40}	insertion loss: receiving LPDA attenuator	0,00
u_{j40}	insertion loss: transmitting LPDA attenuator	0,00
u_{j47}	receiving device: absolute level	
u_{j48}	receiving device: linearity	
u_{j16}	range length	0,00
u_{j03}	reflectivity of absorber material: transmitting antenna to the receiving antenna	
u_{j44}	antenna: antenna factor of the receiving LPDA	
u_{j44}	antenna: antenna factor of the transmitting LPDA	
u_{j22}	position of the phase centre: receiving LPDA	
u_{j22}	position of the phase centre: transmitting LPDA	
u_{j23}	position of the phase centre: LPDA	
u_{j07}	mutual coupling: receiving LPDA and its images in the absorbing material	
u_{j07}	mutual coupling: transmitting LPDA and its images in the absorbing material	
u_{j34}	ambient effect	0,00
u_{j01}	random uncertainty (see note in clause A.18 of TR 102 273-1-2 [7] and note in clause 6.4.7 of TR 102 273-1-1 [6])	

The standard uncertainties from table 16 should be combined by RSS in accordance with clause 5 of TR 102 273-1-1 [6]. This gives the combined standard uncertainty ($u_{c \text{ NSA measurement}}$) for the NSA measurement of in dB.

11.3 Expanded uncertainty of the verification procedure

The combined standard uncertainty of the results of the verification procedure is the combination of the components outlined in clauses 6.7.1 and 6.7.2. The components to be combined are $u_{c \text{ direct attenuation measurement}}$ and

$u_{c \text{ NSA measurement}}$

$$u_c = \sqrt{u_{c \text{ directattenuationmeasurement}}^2 + u_{c \text{ NSAmeasurement}}^2} = _, _ \text{ dB} \quad (6.10)$$

The expanded uncertainty is $\pm 1,96 \times u_c = \pm _, _ \text{ dB}$ at a 95 % confidence level.

12 Calculation of measurement uncertainty (Procedure 3)

12.1 Uncertainty contribution, direct attenuation measurement

The verification procedure involves two different measurement stages and the derivation of NSA. The first stage (the reference) is with all the items of test equipment connected directly together via an adapter between the attenuators as shown in figure 25 (components shown shaded are common to both stages of the procedure).

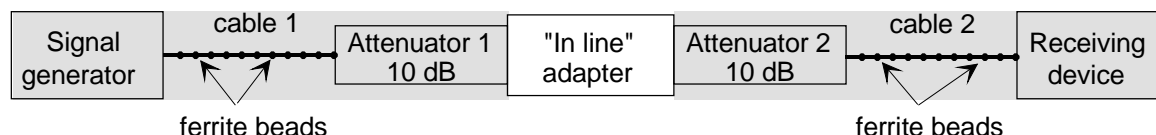

Figure 25: Stage 1: Direct attenuation measurement for the verification procedure

Despite the commonality of most of the components to both stages of this procedure, the mismatch uncertainty contribution from both stages has to be calculated and included in the uncertainty calculations, since the load conditions vary i.e. antennas replace the adapter in the second stage. Conversely, as a result of this commonality, the uncertainty contribution of some of the individual components will cancel.

The magnitude of the random uncertainty contribution to this stage of the procedure can be assessed from multiple repetition of the direct attenuation measurement. All the uncertainty components which contribute to this stage of the test are listed in table 13. Annex A should be consulted for the sources and/or magnitudes of the uncertainty contributions.

Table 18: Contributions from the direct attenuation measurement

$u_{j \text{ or } i}$	Description of uncertainty contributions	dB
u_{j35}	mismatch: direct attenuation measurement	
u_{j38}	signal generator: absolute output level	
u_{j39}	signal generator: output level stability	
u_{j19}	cable factor: receiving antenna	0,00
u_{j19}	cable factor: transmitting antenna	0,00
u_{j41}	insertion loss: receiving antenna cable	0,00
u_{j41}	insertion loss: transmitting antenna cable	0,00
u_{j40}	insertion loss: receiving antenna attenuator	0,00
u_{j40}	insertion loss: transmitting antenna attenuator	0,00
u_{j42}	insertion loss: adapter	
u_{j47}	receiving device: absolute level	0,00
u_{j48}	receiving device: linearity	0,00
u_{01}	random uncertainty (see note in clause A.18 of TR 102 273-1-2 [7] and note in clause 6.4.7 of TR 102 273-1-1 [6])	

The standard uncertainties from table 13 should be combined by RSS in accordance with clause 5 of TR 102 273-1-1 [6]. This gives the combined standard uncertainty ($u_{c \text{ direct attenuation measurement}}$) for the direct attenuation measurement in dB.

12.2 Uncertainty contribution, NSA measurement

This stage involves removing the adapter and connecting each attenuator to an antenna as shown in figure 26, and recording the new level on the receiving device.

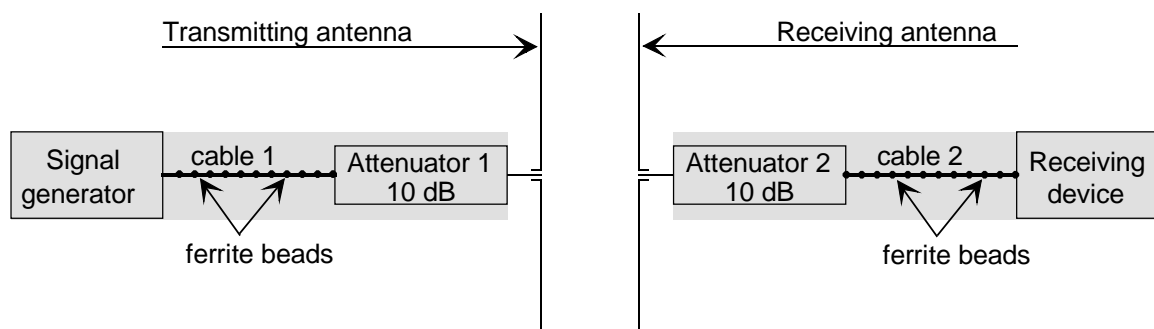

Figure 26: Stage 2: NSA measurement

The difference in received levels (after allowance for any correction factors which may be appropriate), for the same signal generator output level, reveals the NSA. All the uncertainty components which contribute to this stage of the test are listed in table 14. Annex A should be consulted for the sources and/or magnitudes of the uncertainty contributions.

Table 19: Contributions from the NSA measurement

<i>u_j</i> or <i>i</i>	Description of uncertainty contributions	dB
<i>u_{j36}</i>	mismatch: transmitting part	
<i>u_{j37}</i>	mismatch: receiving part	
<i>u_{j38}</i>	signal generator: absolute output level	
<i>u_{j39}</i>	signal generator: output level stability	
<i>u_{j19}</i>	cable factor: receiving antenna	
<i>u_{j19}</i>	cable factor: transmitting antenna	
<i>u_{j41}</i>	insertion loss: receiving antenna cable	0,00
<i>u_{j41}</i>	insertion loss: transmitting antenna cable	0,00
<i>u_{j40}</i>	insertion loss: receiving antenna attenuator	0,00
<i>u_{j40}</i>	insertion loss: transmitting antenna attenuator	0,00
<i>u_{j47}</i>	receiving device: absolute level	
<i>u_{j48}</i>	receiving device: linearity	
<i>u_{j16}</i>	range length	
<i>u_{j03}</i>	reflectivity of absorber material: transmitting antenna to the receiving antenna	
<i>u_{j44}</i>	antenna: antenna factor of the receiving antenna	
<i>u_{j44}</i>	antenna: antenna factor of the transmitting antenna	
<i>u_{j46}</i>	antenna: tuning of the receiving antenna	
<i>u_{j46}</i>	antenna: tuning of the transmitting antenna	
<i>u_{j22}</i>	position of the phase centre: receiving antenna	
<i>u_{j22}</i>	position of the phase centre: transmitting antenna	
<i>u_{j07}</i>	mutual coupling: transmitting antenna to its images in the absorbing material	
<i>u_{j07}</i>	mutual coupling: receiving antenna to its images in the absorbing material	
<i>u_{j10}</i>	mutual coupling: transmitting antenna to the receiving antenna	
<i>u_{j12}</i>	mutual coupling: interpolation of mutual coupling and mismatch loss correction factors	
<i>u_{j34}</i>	ambient effect	
<i>u_{j01}</i>	random uncertainty (see note in clause A.18 of TR 102 273-1-2 [7] and note in clause 6.4.7 of TR 102 273-1-1 [6])	

The standard uncertainties from table 14 should be combined by RSS in accordance with clause 5 of TR 102 273-1-1 [6]. This gives the combined standard uncertainty ($u_{c, NSA \text{ measurement}}$) for the NSA measurement in dB.

12.3 Expanded uncertainty of the verification procedure

The combined standard uncertainty of the results of the verification procedure is the combination of the components outlined in clauses 6.6.1 and 6.6.2. The components to be combined are: u_c direct attenuation measurement and u_c NSA measurement

$$u_c = \sqrt{u_{c \text{ direct attenuation measurement}}^2 + u_{c \text{ NSA measurement}}^2} = _, _ \text{ dB} \quad (6.7)$$

The expanded uncertainty is $\pm 1,96 \times u_c = \pm _, _ \text{ dB}$ at a 95 % confidence level.

13 Calculation of measurement uncertainty (Procedure 4)

13.1 Uncertainty contribution, direct attenuation measurement

The verification procedure involves two different measurement stages and the derivation of NSA. The first stage (the reference) is with all the items of test equipment connected directly together via an adapter between the attenuators as shown in figure 27 (components shown shaded are common to both stages of the procedure).

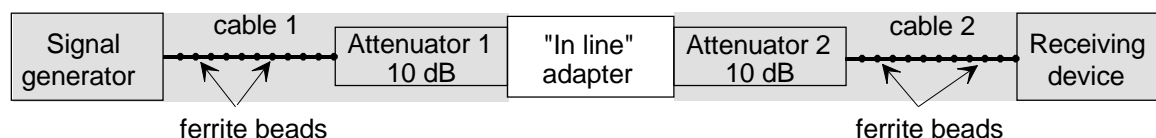

Figure 27: Stage 1: Direct attenuation measurement for the verification procedure

Despite the commonality of most of the components to both stages of this procedure, the mismatch uncertainty contribution from both stages has to be calculated and included in the uncertainty calculations, since the load conditions vary i.e. antennas replace the adapter in the second stage. Conversely, as a result of this commonality, the uncertainty contribution of some of the individual components will cancel.

The magnitude of the random uncertainty contribution to this stage of the procedure can be assessed from multiple repetition of the direct attenuation measurement. All the uncertainty components which contribute to this stage of the test are listed in table 13. Annex A should be consulted for the sources and/or magnitudes of the uncertainty contributions.

Table 20: Contributions from the direct attenuation measurement

$u_{j \text{ or } i}$	Description of uncertainty contributions	dB
u_{j35}	mismatch: direct attenuation measurement	
u_{j38}	signal generator: absolute output level	
u_{j39}	signal generator: output level stability	
u_{j19}	cable factor: receiving antenna	0,00
u_{j19}	cable factor: transmitting antenna	0,00
u_{j41}	insertion loss: receiving antenna cable	0,00
u_{j41}	insertion loss: transmitting antenna cable	0,00
u_{j40}	insertion loss: receiving antenna attenuator	0,00
u_{j40}	insertion loss: transmitting antenna attenuator	0,00
u_{j42}	insertion loss: adapter	
u_{j47}	receiving device: absolute level	0,00
u_{j48}	receiving device: linearity	0,00
u_{01}	random uncertainty (see note in clause A.18 of TR 102 273-1-2 [7] and note in clause 6.4.7 of TR 102 273-1-1 [6])	

The standard uncertainties from table 13 should be combined by RSS in accordance with clause 5 of TR 102 273-1-1 [6]. This gives the combined standard uncertainty (u_c direct attenuation measurement) for the direct attenuation measurement in dB.

13.2 Uncertainty contribution, NSA measurement

This stage involves removing the adapter and connecting each attenuator to an antenna as shown in figure 28, and recording the new level on the receiving device.

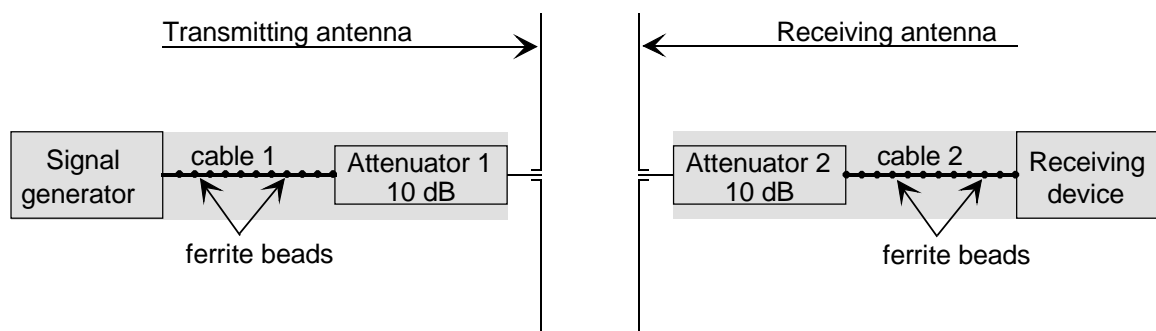

Figure 28: Stage 2: NSA measurement

The difference in received levels (after allowance for any correction factors which may be appropriate), for the same signal generator output level, reveals the NSA. All the uncertainty components which contribute to this stage of the test are listed in table 14. Annex A should be consulted for the sources and/or magnitudes of the uncertainty contributions.

Table 21: Contributions from the NSA measurement

<i>uj</i> or <i>i</i>	Description of uncertainty contributions	dB
u_{j36}	mismatch: transmitting part	
u_{j37}	mismatch: receiving part	
u_{j38}	signal generator: absolute output level	
u_{j39}	signal generator: output level stability	
u_{j19}	cable factor: receiving antenna	
u_{j19}	cable factor: transmitting antenna	
u_{j41}	insertion loss: receiving antenna cable	0,00
u_{j41}	insertion loss: transmitting antenna cable	0,00
u_{j40}	insertion loss: receiving antenna attenuator	0,00
u_{j40}	insertion loss: transmitting antenna attenuator	0,00
u_{j47}	receiving device: absolute level	
u_{j48}	receiving device: linearity	
u_{j16}	range length	
u_{j03}	reflectivity of absorber material: transmitting antenna to the receiving antenna	
u_{j44}	antenna: antenna factor of the receiving antenna	
u_{j44}	antenna: antenna factor of the transmitting antenna	
u_{j46}	antenna: tuning of the receiving antenna	
u_{j46}	antenna: tuning of the transmitting antenna	
u_{j22}	position of the phase centre: receiving antenna	
u_{j22}	position of the phase centre: transmitting antenna	
u_{j07}	mutual coupling: transmitting antenna to its images in the absorbing material	
u_{j07}	mutual coupling: receiving antenna to its images in the absorbing material	
u_{j10}	mutual coupling: transmitting antenna to the receiving antenna	
u_{j12}	mutual coupling: interpolation of mutual coupling and mismatch loss correction factors	
u_{j34}	ambient effect	
u_{j01}	random uncertainty (see note in clause A.18 of TR 102 273-1-2 [7] and note in clause 6.4.7 of TR 102 273-1-1 [6])	

The standard uncertainties from table 14 should be combined by RSS in accordance with clause 5 of TR 102 273-1-1 [6]. This gives the combined standard uncertainty ($u_{c \text{ NSA measurement}}$) for the NSA measurement in dB.

13.3 Expanded uncertainty of the verification procedure

The combined standard uncertainty of the results of the verification procedure is the combination of the components outlined in clauses 6.6.1 and 6.6.2. The components to be combined are: $u_{c \text{ direct attenuation measurement}}$ and

$u_{c \text{ NSA measurement}}$

$$u_c = \sqrt{u_{c \text{ direct attenuation measurement}}^2 + u_{c \text{ NSA measurement}}^2} = _, _ \text{ dB} \quad (6.7)$$

The expanded uncertainty is $\pm 1,96 \times u_c = \pm _, _ \text{ dB}$ at a 95 % confidence level.

14 Summary

The expanded uncertainty values derived in clauses 6.6.3 and 6.7.3 reveal the uncertainty with which the NSA can be measured. Any value of NSA that varies by more than these uncertainty values from the theoretical value is probably due to imperfection(s) in the site. These imperfections may be due to reflections from a range of possible sources in the anechoic chamber at the time the verification procedure is carried out and should therefore be investigated.

Annex A (informative): Bibliography

- "A designers guide to shielding", Hewlett Packard: RF and microwave measurement symposium and exhibition.
- "Calculation of site attenuation from antenna factors" A. A. Smith Jr, RF German and J B Pate. IEEE transactions EMC. Vol. EMC 24 pp 301-316 Aug 1982.
- "The expression of uncertainty in electrical measurement", B3003, November 1987 National Measurement Accreditation Service (NAMAS).
- "Uncertainties of Measurement for NATLAS electrical testing laboratories. NAMAS policy and general notes", National Testing Laboratory Accreditation Scheme (NATLAS), NIS20 July 1986 (English)
- "Standard site method for determining antenna factors", A. A. Smith Jr. IEEE transactions EMC. Vol EMC 24 pp 316-322 Aug 1982.
- Guide to the Expression of Uncertainty in Measurement (International Organization for Standardization, Geneva, Switzerland, 1995).
- "Vocabulary of metrology", British Standard Institution (BSI): PD 6461: Part 2: September 1980.

History

Document history		
V1.1.1	May 2004	Publication