

ETSI TS 101 889-1 V1.1.1 (2002-08)

Technical Specification

**Telecommunications and Internet Protocol
Harmonization Over Networks (TIPHON) Release 3;
Technology Compliance Specification;
TIPHON profile for IUT-T H.248;
Part 1: Protocol Implementation Conformance
Statement (PICS) proforma specification**



Reference

DTS/TIPHON-06017-1

Keywords

H.248, IP, PICS, supplementary service,
telephony, testing, VoIP

ETSI

650 Route des Lucioles
F-06921 Sophia Antipolis Cedex - FRANCE

Tel.: +33 4 92 94 42 00 Fax: +33 4 93 65 47 16

Siret N° 348 623 562 00017 - NAF 742 C
Association à but non lucratif enregistrée à la
Sous-Préfecture de Grasse (06) N° 7803/88

Important notice

Individual copies of the present document can be downloaded from:

<http://www.etsi.org>

The present document may be made available in more than one electronic version or in print. In any case of existing or perceived difference in contents between such versions, the reference version is the Portable Document Format (PDF). In case of dispute, the reference shall be the printing on ETSI printers of the PDF version kept on a specific network drive within ETSI Secretariat.

Users of the present document should be aware that the document may be subject to revision or change of status. Information on the current status of this and other ETSI documents is available at

<http://portal.etsi.org/tb/status/status.asp>

If you find errors in the present document, send your comment to:

editor@etsi.fr

Copyright Notification

No part may be reproduced except as authorized by written permission.
The copyright and the foregoing restriction extend to reproduction in all media.

© European Telecommunications Standards Institute 2002.
All rights reserved.

DECTTM, **PLUGTESTS**TM and **UMTS**TM are Trade Marks of ETSI registered for the benefit of its Members.
TIPHONTM and the **TIPHON logo** are Trade Marks currently being registered by ETSI for the benefit of its Members.
3GPPTM is a Trade Mark of ETSI registered for the benefit of its Members and of the 3GPP Organizational Partners.

Contents

Intellectual Property Rights	5
Foreword.....	5
Introduction	6
1 Scope	7
2 References	7
3 Definitions and abbreviations.....	9
3.1 Definitions	9
3.2 Abbreviations	9
4 Conformance to this PICS proforma specification.....	9
Annex A (normative): PICS proforma for ITU-T Recommendation H.248.1 as specified in TS 101 885	10
A.1 Guidance for completing the PICS proforma.....	10
A.1.1 Purposes and structure.....	10
A.1.2 Abbreviations and conventions	10
A.1.3 Instructions for completing the PICS proforma.....	12
A.2 Identification of the implementation	13
A.2.1 Date of the statement	13
A.2.2 Implementation Under Test (IUT) identification	13
A.2.3 System Under Test (SUT) identification	13
A.2.4 Product supplier.....	13
A.2.5 Client (if different from product supplier).....	14
A.2.6 PICS contact person	14
A.3 PICS/System Conformance Statement (SCS)	15
A.4 Identification of the protocol.....	15
A.5 Global statement of conformance.....	15
A.6 General Remarks	16
A.6.1 TIPHON interfaces.....	16
A.6.2 General mapping between H.248.1 and TIPHON parameters.....	16
A.6.3 General structure of the H.248.1 messages	17
A.7 Major functional capabilities.....	17
A.7.1 Role of the Implementation Under Test (IUT).....	17
A.7.2 General properties of the IUT.....	18
A.7.3 Transactions	19
A.7.4 Contexts.....	19
A.7.5 Terminations.....	20
A.7.6 Commands applying to Terminations.....	20
A.7.7 Descriptors applying to Commands	21
A.8 Basic signalling procedures.....	22
A.8.1 Transaction procedures.....	22
A.8.2 Context procedures.....	22
A.8.3 Command procedures.....	23
A.9 Protocol messages sent by the IUT	24
A.9.1 H.248/MEGACO message PDU	24
A.9.2 Transactions	25
A.9.2.1 Transaction Request.....	25
A.9.2.2 Transaction Reply	25
A.9.2.3 Transaction Pending	25

A.9.2.4	Transaction ResponseAck.....	25
A.9.3	Contexts.....	26
A.9.3.1	Action Request.....	26
A.9.3.2	Action Reply.....	26
A.9.4	Commands.....	27
A.9.4.1	Command Requests.....	27
A.9.4.1.1	Add Command Request.....	27
A.9.4.1.2	Modify Command Request.....	27
A.9.4.1.3	Substract Command Request.....	28
A.9.4.1.4	Move Command Request.....	28
A.9.4.1.5	AuditValue Command Request.....	28
A.9.4.1.6	AuditCapabilities Command Request.....	28
A.9.4.1.7	Notify Command Request.....	29
A.9.4.1.8	ServiceChange Command Request.....	29
A.9.4.2	Command Replies.....	29
A.9.4.2.1	Add Command Reply.....	29
A.9.4.2.2	Modify Command Reply.....	30
A.9.4.2.3	Subtract Command Reply.....	30
A.9.4.2.4	Move Command Reply.....	31
A.9.4.2.5	AuditValue Command Reply.....	31
A.9.4.2.6	AuditCapabilities Command Reply.....	32
A.9.4.2.7	Notify Command Reply.....	32
A.9.4.2.8	Service Change Command Reply.....	32
A.9.5	Descriptors.....	33
A.9.5.1	Media Descriptor.....	33
A.9.5.2	Termination State Descriptor.....	33
A.9.5.3	Stream Descriptor.....	34
A.9.5.4	Local Descriptor.....	34
A.9.5.5	Remote Descriptor.....	34
A.9.5.6	Local Control Descriptor.....	35
A.9.5.7	ServiceChange Descriptor.....	35
A.9.5.8	Statistics Descriptor.....	36
A.9.5.9	Error Descriptor.....	36
A.10	Support of annexes/Packages.....	37
A.10.1	Annex C: Tags for Media Stream Properties.....	37
A.10.2	Annex D: Transport over IP.....	37
A.10.2.1	Transport over IP/UDP.....	37
A.10.2.2	Transport over IP/TCP.....	38
A.10.3	Annex E: Basic Packages.....	38
A.10.4	Annex L: Error Code descriptions.....	39
A.10.5	Additional annexes and Packages.....	39
A.11	Timers and Parameters.....	40
A.11.1	Timers.....	40
A.11.2	IUT Parameters.....	40
A.12	Support of specific procedures for the TIPHON interfaces according to the TIPHON release 3 profile.....	41
A.12.1	Specific PICS for TIPHON interface N2 according to TS 101 885.....	41
A.12.2	Specific PICS for TIPHON interface N3 according to TS 101 885.....	41
	History.....	42

Intellectual Property Rights

IPRs essential or potentially essential to the present document may have been declared to ETSI. The information pertaining to these essential IPRs, if any, is publicly available for **ETSI members and non-members**, and can be found in ETSI SR 000 314: "*Intellectual Property Rights (IPRs); Essential, or potentially Essential, IPRs notified to ETSI in respect of ETSI standards*", which is available from the ETSI Secretariat. Latest updates are available on the ETSI Web server (<http://webapp.etsi.org/IPR/home.asp>).

Pursuant to the ETSI IPR Policy, no investigation, including IPR searches, has been carried out by ETSI. No guarantee can be given as to the existence of other IPRs not referenced in ETSI SR 000 314 (or the updates on the ETSI Web server) which are, or may be, or may become, essential to the present document.

Foreword

This Technical Specification (TS) has been produced by ETSI Project Telecommunications and Internet Protocol Harmonization Over Networks (TIPHON).

The present document is part 1 of a multi-part deliverable covering Conformance Testing for TIPHON Release 3; TIPHON profile for ITU-T recommendation H.248.1 [20], as identified below:

- Part 1: "Protocol Implementation Conformance Statement (PICS) proforma specification";**
- Part 2: "Test Suite Structure and Test Purposes (TSS&TP) specification";
- Part 3: "Abstract Test Suite (ATS) and partial Protocol Implementation eXtra Information for Testing (PIXIT) proforma specification".

Introduction

To evaluate conformance of a particular implementation, it is necessary to have a statement of which capabilities and options have been implemented for a telecommunication specification. Such a statement is called an Implementation Conformance Statement (ICS).

Figure 1 shows the relationship of the present document with other TIPHON release 3 deliverables.

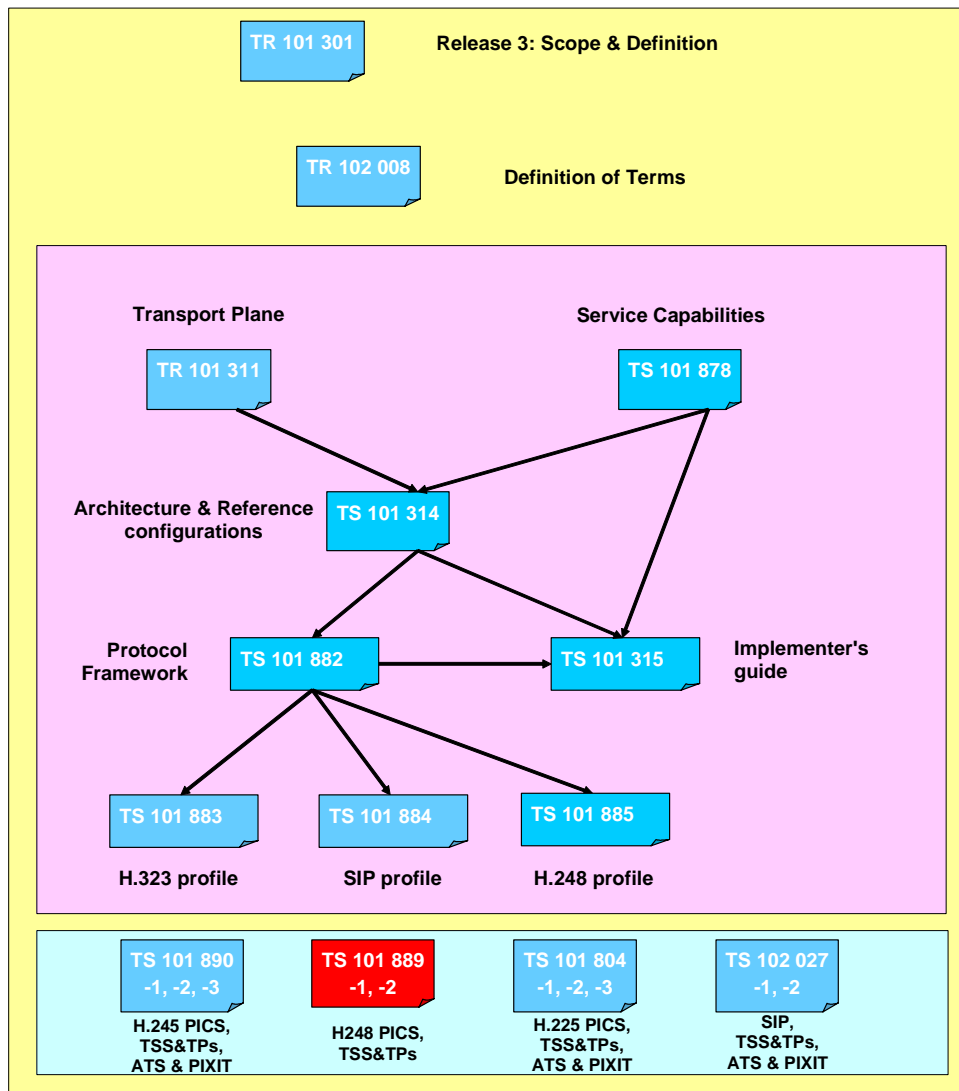

Figure 1: Relationship with other TIPHON release 3 documents

1 Scope

The present document provides the Protocol Implementation Conformance Statement (PICS) proforma for the audiovisual and multimedia systems Infrastructure of audiovisual services - Communication procedures, Gateway control protocol, ITU-T Recommendation H.248.1 [20] in compliance with the relevant requirements specified in TS 101 885 [1] and in accordance with the relevant guidance given in ISO/IEC 9646-7 [22].

The supplier of a protocol implementation which is claimed to conform to TIPHON mapping to H.248.1 [20] is required to complete a copy of the PICS proforma provided in annex A of the present document and is required to provide the information necessary to identify both the supplier and the implementation.

2 References

The following documents contain provisions which, through reference in this text, constitute provisions of the present document.

- References are either specific (identified by date of publication and/or edition number or version number) or non-specific.
- For a specific reference, subsequent revisions do not apply.
- For a non-specific reference, the latest version applies.

- [1] ETSI TS 101 885: "Telecommunications and Internet Protocol Harmonization Over Networks (TIPHON) Release 3; Technology Mapping; Technology Mapping of TIPHON reference point N to H.248/MEGACO protocol".
- [2] ETSI TR 101 301: "Telecommunications and Internet Protocol Harmonization Over Networks (TIPHON) Release 3; Release Definition; TIPHON Release 3 Definition".
- [3] ETSI TR 102 008: "Telecommunications and Internet Protocol Harmonization Over Networks (TIPHON) Release 3; Terms and Definitions".
- [4] ETSI TR 101 311: "Telecommunications and Internet Protocol Harmonization Over Networks (TIPHON) Release 3; Service Independent requirements definition; Transport Plane".
- [5] ETSI TS 101 878: "Telecommunications and Internet Protocol Harmonization Over Networks (TIPHON) Release 3; Service Capability Definition; Service Capabilities for a simple call".
- [6] ETSI TS 101 314: "Telecommunications and Internet Protocol Harmonization Over Networks (TIPHON) Release 3; Abstract Architecture and Reference Points Definition; Network Architecture and Reference Points".
- [7] ETSI TS 101 882: "Telecommunications and Internet Protocol Harmonization Over Networks (TIPHON) Release 3; Protocol Framework Definition; General (meta-protocol)".
- [8] ETSI TS 101 315: "Telecommunications and Internet Protocol Harmonization Over Networks (TIPHON) Release 3; Functional entities, information flow and reference point definitions; Guidelines for application of TIPHON functional architecture to inter-domain services".
- [9] ETSI TS 101 883: "Telecommunications and Internet Protocol Harmonization Over Networks (TIPHON) Release 3; Technology Mapping; Implementation of TIPHON architecture using H.323".
- [10] ETSI TS 101 884: "Telecommunications and Internet Protocol Harmonization Over Networks (TIPHON) Release 3; Technology Mapping; Implementation of TIPHON architecture using SIP".
- [11] ETSI TS 101 890-1: "Telecommunications and Internet Protocol Harmonization Over Networks (TIPHON) Release 3; Technology Compliance Specifications; TIPHON profile for ITU-T H.245; Part 1: Protocol Implementation Conformance Statement (PICS) proforma specification".

- [12] ETSI TS 101 890-2: "Telecommunications and Internet Protocol Harmonization Over Networks (TIPHON) Release 3; Technology Compliance Specifications; TIPHON profile for ITU-T H.245; Part 2: Test Suite Structure and Test Purposes (TSS&TP) specification".
- [13] ETSI TS 101 890-3: "Telecommunications and Internet Protocol Harmonization Over Networks (TIPHON) Release 3; Technology Compliance Specifications; TIPHON profile for ITU-T H.245; Part 3: Abstract Test Suite (ATS) and partial Protocol Implementation eXtra Information for Testing (PIXIT) proforma specification".
- [14] ETSI TS 101 889-2: "Telecommunications and Internet Protocol Harmonization Over Networks (TIPHON) Release 3; Technology Compliance Specification; TIPHON profile for ITU-T H.248; Part 2: Test Suite Structure and Test Purposes (TSS&TP) specification".
- [15] ETSI TS 101 804-1: "Telecommunications and Internet Protocol Harmonization Over Networks (TIPHON) Release 3; Technology compliance specifications; Part 1: Revision/Update of H.225.0 Protocol Implementation Conformance Statement (PICS) proforma specification for Terminal, Gatekeeper and Gateway".
- [16] ETSI TS 101 804-2: "Telecommunications and Internet Protocol Harmonization Over Networks (TIPHON) Release 3; Technology compliance specifications; Part 2: H.225.0 conformance test specifications; Test Suite Structure and Test Purposes (TSS&TP) specification for Terminal, Gatekeeper and Gateway".
- [17] ETSI TS 101 804-3: "Telecommunications and Internet Protocol Harmonization Over Networks (TIPHON) Release 3; Technology compliance specifications; Part 3: H.225.0 conformance test specifications; Abstract Test Suite (ATS) and PIXIT proforma specification for Terminal, Gatekeeper and Gateway".
- [18] ETSI TS 102 027-1: "Telecommunications and Internet Protocol Harmonization Over Networks (TIPHON); Technology Compliance Specification; Draft IETF SIP RFC2543bis-04; Part 1: Test Suite Structure and Test Purposes (TSS&TP) specification;".
- [19] ETSI TS 102 027-2: "Telecommunications and Internet Protocol Harmonization Over Networks (TIPHON); Technology Compliance Specification; Draft IETF SIP RFC2543bis-04; Part 2: Abstract Test Suite (ATS) and partial Protocol Implementation eXtra Information for Testing (PIXIT) proforma specification".
- [20] ITU-T Recommendation H.248.1.1: "Gateway control protocol: Version 1"..
- [21] ISO/IEC 9646-1 (1994): "Information technology - Open Systems Interconnection - Conformance testing methodology and framework - Part 1: General concepts".
- [22] ISO/IEC 9646-7 (1995): "Information technology - Open Systems Interconnection - Conformance testing methodology and framework - Part 7: Implementation Conformance Statements".
- [23] ETSI TS 101 882: "Protocol Framework Telecommunications and Internet Protocol Harmonization Over Networks (TIPHON) Release 3; Protocol Framework Definition; General (meta-protocol)".

3 Definitions and abbreviations

3.1 Definitions

For the purposes of the present document, the following terms and definitions apply:

- terms defined in ITU-T Recommendation H.248.1 [20];
- terms defined in ISO/IEC 9646-1 [21] and in ISO/IEC 9646-7 [22].

In particular, the following terms defined in ISO/IEC 9646-1 [21] apply:

Implementation Conformance Statement (ICS): statement made by the supplier of an implementation or system claimed to conform to a given specification, stating which capabilities have been implemented

NOTE: The PICS can take several forms: protocol PICS, profile PICS, profile specific PICS, information object PICS, etc.

Protocol ICS (PICS): ICS for an implementation or system claimed to conform to a given protocol specification

3.2 Abbreviations

For the purposes of the present document, the following abbreviations apply:

ICS	Implementation Conformance Statement
IUT	Implementation Under Test
MG	Media Gateway
MGC	Media Gateway Controller
PDU	Protocol Data Unit
PICS	Protocol Implementation Conformance Statement
SCS	System Conformance Statement
SUT	System Under Test

4 Conformance to this PICS proforma specification

If it claims to conform to the present document, the actual PICS proforma to be filled in by a supplier shall be technically equivalent to the text of the PICS proforma given in annex A, and shall preserve the numbering/naming and ordering of the proforma items.

A PICS which conforms to the present document shall be a conforming PICS proforma completed in accordance with the guidance for completion given in clause A.1.

Annex A (normative): PICS proforma for ITU-T Recommendation H.248.1 as specified in TS 101 885

Notwithstanding the provisions of the copyright clause related to the text of the present document, ETSI grants that users of the present document may freely reproduce the PICS proforma in this annex so that it can be used for its intended purposes and may further publish the completed PICS.
--

A.1 Guidance for completing the PICS proforma

A.1.1 Purposes and structure

The purpose of this PICS proforma is to provide a mechanism whereby a supplier of an implementation of the requirements defined in ITU-T Recommendation H.248.1 may provide information about the implementation in a standardized manner.

The PICS proforma is subdivided into clauses for the following categories of information:

- guidance for completing the PICS proforma;
- identification of the implementation;
- identification of the protocol;
- global statement of conformance;
- general remarks;
- roles and major capabilities;
- basic procedures;
- coding supported by the IUT;
- support of annexes/packages;
- timers and parameters

A.1.2 Abbreviations and conventions

The PICS proforma contained in this annex is comprised of information in tabular form in accordance with the guidelines presented in ISO/IEC 9646-7.

Item column

The item column contains a number which identifies the item in the table.

Item description column

The item description column describes in free text each respective item (for example parameters, timers, etc.). It implicitly means "is < item description > supported by the implementation?".

Status column

The following notations, defined in ISO/IEC 9646-7, are used for the status column:

m	mandatory - the capability is required to be supported;
o	optional - the capability may be supported or not;
n/a	not applicable - in the given context, it is impossible to use the capability;
x	prohibited (excluded) - there is a requirement not to use this capability in the given context;
o.i	qualified optional - for mutually exclusive or selectable options from a set. "i" is an integer which identifies a unique group of related optional items and the logic of their selection which is defined immediately following the table;
c.i	conditional - the requirement on the capability ("m", "o", "x" or "n/a") depends on the support of other optional or conditional items. "i" is an integer identifying a unique conditional status expression which is defined immediately following the table;
i	irrelevant (out-of-scope) - capability outside the scope of the reference specification. No answer is requested from the supplier.

Reference column

The reference column makes reference to ITU-T Recommendation H.248.1 except where explicitly stated otherwise.

Support column

The supplier of the implementation shall fill in the support column. The following common notations, defined in ISO/IEC 9646-7, are used for the support column:

Y or y	supported by the implementation;
N or n	not supported by the implementation;
N/A, n/a or	no answer required (allowed only if the status is n/a, directly or after evaluation of a conditional status).

If this PICS proforma is completed in order to describe a multiple-profile support in a system, it is necessary to be able to answer that a capability is supported for one profile and not supported for another. In that case, the supplier shall enter the unique reference to a conditional expression, preceded by "?" (for example ?3). This expression shall be given in the space for comments provided at the bottom of the table. It uses predicates defined in the SCS, each of which refers to a single profile and which takes the value TRUE if and only if that profile is to be used.

EXAMPLE: ?3: IF prof1 THEN Y ELSE N.

It is also possible to provide a comment to an answer in the space provided at the bottom of the table.

NOTE: As stated in ISO/IEC 9646-7, support for a received PDU requires the ability to parse all valid parameters of that PDU. Supporting a PDU while having no ability to parse a valid parameter is non-conformant. Support for a parameter on a PDU means that the semantics of that parameter are supported.

Values allowed column

The values allowed column contains the type, the list, the range, or the length of values allowed. The following notations are used:

- range of values: < min value > .. < max value >:
- example: 5 .. 20.

- List of values: < value1 >, < value2 >,, < valueN >:
 - example: 2, 4, 6, 8, 9;
 - example: '1101'B, '1011'B, '1111'B;
 - example: '0A'H, '34'H, '2F'H.
- List of named values: < name1 >(< val1 >), < name2 >(< val2 >),, < nameN >(< valN >):
 - example: reject(1), accept(2).
- Length: size (< min size > .. < max size >):
 - example: size (1 .. 8).

Values supported column

The values supported column shall be filled in by the supplier of the implementation. In this column, the values or the ranges of values supported by the implementation shall be indicated.

References to items

For each possible item answer (answer in the support column) within the PICS proforma a unique reference exists, used, for example, in the conditional expressions. It is defined as the table identifier, followed by a solidus character "/", followed by the item number in the table. If there is more than one support column in a table, the columns are discriminated by letters (a, b, etc.), respectively.

EXAMPLE 1: A.5/4 is the reference to the answer of item 4 in table 5 of annex A.

EXAMPLE 2: A.6/3b is the reference to the second answer (i.e. in the second support column) of item 3 in table 6 of annex A.

Prerequisite line

A prerequisite line takes the form: Prerequisite: < predicate >.

A prerequisite line after a clause or table title indicates that the whole clause or the whole table is not required to be completed if the predicate is FALSE.

A.1.3 Instructions for completing the PICS proforma

The supplier of the implementation shall complete the PICS proforma in each of the spaces provided. In particular, an explicit answer shall be entered, in each of the support or supported column boxes provided, using the notation described in clause A.1.2.

If necessary, the supplier may provide additional comments in space at the bottom of the tables, or separately on sheets of paper.

More detailed instructions are given at the beginning of the different clauses of the PICS proforma.

A.2 Identification of the implementation

Identification of the Implementation Under Test (IUT) and the system in which it resides (the System Under Test (SUT)) should be filled in so as to provide as much detail as possible regarding version numbers and configuration options.

The product supplier information and client information should both be filled in if they are different.

A person who can answer queries regarding information supplied in the PICS should be named as the contact person.

A.2.1 Date of the statement

.....

A.2.2 Implementation Under Test (IUT) identification

IUT name:

.....

.....

IUT version:

.....

A.2.3 System Under Test (SUT) identification

SUT name:

.....

.....

Hardware configuration:

.....

.....

.....

Operating system:

.....

A.2.4 Product supplier

Name:

.....

Address:

.....

.....

.....

Telephone number:

.....

Facsimile number:

.....

E-mail address:

.....

Additional information:

.....

.....

.....

A.2.5 Client (if different from product supplier)

Name:

.....

Address:

.....

.....

.....

Telephone number:

.....

Facsimile number:

.....

E-mail address:

.....

Additional information:

.....

.....

A.2.6 PICS contact person

(A person to contact if there are any queries concerning the content of the PICS)

Name:

.....

Telephone number:

.....

Facsimile number:

.....

E-mail address:

.....

Additional information:

.....

.....

.....

A.3 PICS/System Conformance Statement (SCS)

Provide the relationship of the PICS with the SCS for the system.

A.4 Identification of the protocol

The PICS proforma applies to the following standard:

- ITU-T Recommendation H.248.1 (Draft V2): "Infrastructure of audiovisual services - Communication procedures, Gateway control protocol".
- ETSI TS 101 885: "Telecommunications and Internet Protocol Harmonization Over Networks (TIPHON) Release 3; Technology Mapping; Technology Mapping of TIPHON reference point N to H.248/MEGACO protocol".

A.5 Global statement of conformance

Are all mandatory capabilities implemented? (Yes/No).

NOTE: Answering "No" to this question indicates non-conformance to the protocol specification. Non-supported mandatory capabilities are to be identified in the PICS, with an explanation of why the implementation is non-conforming, on pages attached to the PICS proforma.

A.6 General Remarks

A.6.1 TIPHON interfaces

Figure 2 shows the TIPHON interfaces, which are relevant for the document.

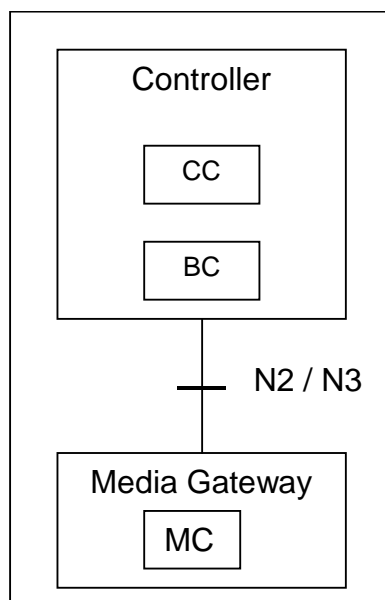

Figure 2: TIPHON interfaces

A.6.2 General mapping between H.248.1 and TIPHON parameters

The actual mapping table between the TIPHON and the H.248.1 protocol primitives as well as the mapping table for binary and text encoding are described in TS 101 885.

A.6.3 General structure of the H.248.1 messages

Figure 3 shows schematically the structure of the protocol messages and the relation of the elements within H.248.1 messages. In principle there are several levels (indicated by the arrows) within the H.248.1 protocol where the command initiator and command responder communicates. These levels are the Transactions, Contexts and Commands. For the Contexts and the Commands the protocol offers a set of descriptors that includes the specific parameters in the actual messages. The PICS tables in the present document follow this concept of different communication levels.

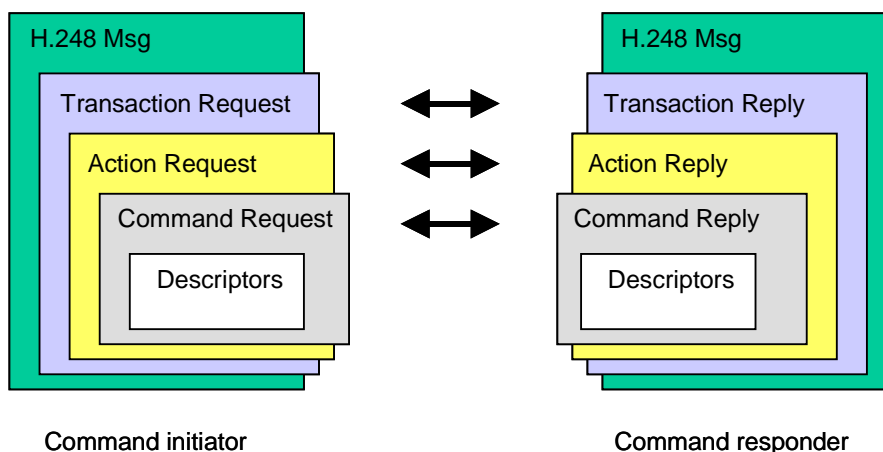

Figure 3: H.248.1 message structure for the command initiator and the command responder

A.7 Major functional capabilities

Mandatory elements in subsequent tables of clause A.7 shall be implemented whereas elements marked as optional are real implementation options. Elements marked as n/a shall not be used within the TIPHON release 3 profile.

A.7.1 Role of the Implementation Under Test (IUT)

Table A.1: Role of Implementation Under Test (IUT)

Item	Role of the IUT	References	H.248 Status	N2/N3 Status	Support Y N n/a
MGC	Media Gateway Controller (MGC)	H.248	o.1	o.1	
MG	Media Gateway (MG)	H.248	o.1	o.1	
o.1: exactly one of the items					
Comments:					

A.7.2 General properties of the IUT

Table A.2: General properties of the IUT

Item	properties of the IUT	H.248 References	H.248 Status	N2/N3 Status	Support Y N n/a
B1	supports the concept of H.248.1 messages	8.3	m	m	
B2	supports the concept of Transactions	8	m	m	
B3	supports the concept of Contexts	6.1	m	m	
B4	supports the concept of Terminations	6.2	m	m	
B5	supports the concept of Commands applying to Terminations	7	m	m	
B6	supports the concept of Descriptors applying to Contexts and Terminations	6.2.4 7.1	m	m	
B7	supports the concept of Packages to characterize Terminations	6.2.3 Annexes	m	m	
B8	supports binary encoding	7.2.10 Annex A	o.2 (see note)	c.1	
B9	supports text encoding	7.2.10 Annex B	o.2 (see note)	c.2	
B10	supports the wildcard mechanism for Context IDs and Termination IDs	8.1.2 6.2.2	m	m	
B11	support of the default port number	9	o	m	
B12	supports message transport using TCP/IP	9	c.3	c.3	
B13	supports message transport using UDP/IP	9	c.3	c.3	
B14	can process overspecified parameters according to the protocol rules	7.1.1	c.4	c.4	
B15	can process underspecified parameters according to the protocol rules	7.1.1	c.4	c.4	
B16	support of the procedures for a cold start	11.2	m	m	
B17	support of the procedures to negotiate the protocol version	11.3	m	m	
B18	supports protection against restart avalanche	9.2	o	m	
<p>o.2: at least one of the items NOTE: A MGC should support both encoding formats, a MG may support both formats.</p> <p>c.1: mandatory for a MGC and a MG within an H.323 environment, ELSE optional c.2: mandatory for a MGC and a MG within a SIP environment, ELSE optional c.3: IF (A.1/MGC) then mandatory IF (A.1/MG) then at least one of the items c.4: IF (A.1/MG) then m ELSE n/a</p>					
Comments:					

A.7.3 Transactions

Table A.3: Transactions

Prerequisite: A.2/B2					
Item	Transaction properties	H.248 References	H.248 Status	N2/N3 Status	Support Y N n/a
C1	support of a Transaction ID in the Transaction messages	8.1.1	m	m	
C2	addressing of at least one Context/action within a Transaction Request or Reply message is supported	8	m	m	
C3	addressing of multiple Contexts/actions within a Transaction Request or Reply message is supported	8	o	o	
C4	support of ordered command processing	8	m	m	
C5	support of a Transaction timer	8	o	m	
Comments:					

A.7.4 Contexts

Table A.4: Contexts

Prerequisite: A.2/B3					
Item	Context properties	H.248.1 Reference	H.248 Status	N2/N3 Status	Support Y N n/a
D1	ability to create a new context	6.1.2	m	m	
D2	ability to delete an existing context	6.1.2	m	m	
D3	ability to modify an existing context	6.1.2	m	m	
D5	ability to create and administrate Context IDs	6.1	c.5	c.5	
D6	support of Context Descriptors	6.1.1	o	n/a	
c.5: IF (A.1/MG) then m ELSE n/a					
Comments:					

A.7.5 Terminations

Table A.5: Terminations

Prerequisite: A.2/B4					
Item	Termination properties	H.248 Reference	H.248 Status	N2/N3 Status	Support Y N n/a
E1	support of creating, modifying and deleting of Terminations	6.2	m	m	
E2	support of moving of a Termination from one Context to an other	6.2	o	o	
E3	support of auditing of Terminations	6.2	o	m	
E4	support of applying Signals to Terminations	6.2	o	n/a	
E5	support of detecting Events on Terminations	6.2	o	o	
E6	support of service changes operations on Terminations	6.2	m	m	
E7	ability to create and administrate Termination IDs	6.2.2	c.6	c.6	
E8	support of the ROOT Termination to address the whole MG	6.2.5	m	m	
c.6: IF (A.1/MG) then m ELSE n/a					
Comments:					

A.7.6 Commands applying to Terminations

Table A.6: H.248.1 Commands

Prerequisite: A.2/B5					
Item	H.248.1 commands	H.248 References	H.248 Status	N2/N3 Status	Support Y N n/a
F1	Add: Adds a termination to a context	7	m	m	
F2	Modify: Modifies the properties of the Termination	7	m	m	
F3	Subtract: Disconnects the Termination from the context	7	m	m	
F4	Move: Moves a Termination to another context from its current context	7	o	o	
F5	Audit Value: Returns the current state of properties, events, signals and statistics of Terminations.	7	o	m	
F6	Audit Capability: Returns all the possible values of Termination properties, events and signals allowed by MG	7	o	o	
F7	Notify: Allows the MG to inform the MGC about the events occurring in the MG	7	o	o	
F8	Service Change: Allows the MG to notify the MGC that the Termination or a group of Termination is about to be taken out of service or is just returned to service	7	m	m	
Comments:					

A.7.7 Descriptors applying to Commands

Table A.7: Command Descriptors

Prerequisite: A.2/B6					
Item	H.248.1 Descriptors	H.248 References	H.248 Status	N2/N3 Status	Support Y N n/a
G1	Modem: Identifies modem type and properties when applicable	7.1.2	o	n/a	
G2	Mux: Describes multiplex type for multimedia terminations (e.g. H.221, H.223, H.226) and Terminations forming the input mux	7.1.3	o	n/a	
G3	Media: Contains the Termination State, Stream, Local, Remote and/or Local Control Descriptors	7.1.4	m	m	
G4	Termination State: Properties of a Termination (which can be defined in Packages) that are not stream specific	7.1.5	o	m	
G5	Stream: Specifies the parameters of a single Bi-directional stream	7.1.6	o	m	
G6	Local: Contains properties that specify the media flows that the MG receives from the remote entity	7.1.8	m	m	
G7	Remote: Contains properties that specify the media flows that the MG sends to the remote entity	7.1.8	m	m	
G8	LocalControl: Contains properties (which can be defined in packages) that are of interest between the MG and the MGC	7.1.7	m	m	
G9	Events: Describes events to be detected by the MG and what to do when an event is detected	7.1.9	o	o	
G10	EventBuffer: Describes events to be detected by the MG when Event Buffering is active	7.1.10	o	n/a	
G11	Signals: Describes signals and/or actions to be applied (e.g. Busy Tone) to the Terminations	7.1.11	o	n/a	
G12	Audit: Audit descriptor identifies which information is desired	7.1.12	m	m	
G13	Packages: Used only with AuditValue, returns a list of Packages realized by the Termination	7.1.16	o	n/a	
G14	DigitMap: Defines patterns against which sequences of a specified set of events are to be matched so they can be reported as a group rather than singly	7.1.14	o	n/a	
G15	Service Change: Service Change defines what and why service change occurred, etc.	7.1.13	m	m	
G16	ObservedEvents: Defines the report of events observed in Notify or AuditValue	7.1.17	o	o	
G17	Statistics: In Subtract and Audit, Report of Statistics kept on a Termination	7.1.15	o	m	
G18	Topology: Specifies flow directions between Terminations in a Context	7.1.18	o	n/a	
G19	Error: Contains an error code and optionally error text; it may occur in command replies and Notify requests	7.1.20	m	m	
Comments:					

A.8 Basic signalling procedures

Mandatory elements in subsequent tables of clause A.8 shall be implemented whereas elements marked as optional are real implementation options. Elements marked as n/a shall not be used within the TIPHON release 3 profile.

A.8.1 Transaction procedures

Table A.8: Transaction procedures

Prerequisite: A.2/B2					
Item	Procedures	H.248 References	H.248 Status	N2/N3 Status	Support Y N n/a
H1	can send a Transaction Request and can receive a Transaction Reply	8.2.1 8.2.2	m	m	
H2	can receive a Transaction Pending instead of a Transaction reply	8.2.3	m	m	
H3	can send a Transaction ResponseAck	Annex D	c.7	c.7	
c.7: IF Transport protocol is UDP then mandatory, IF Transport protocol is TCP then optional					
Comments:					

A.8.2 Context procedures

Table A.9: Context procedures

Prerequisite: A.2/B3					
Item	Procedures	H.248 References	H.248 Status	N2/N3 Status	Support Y N n/a
I1	can send an Action Request and can receive an Action Reply	7.2.1	m	m	
Comments:					

A.8.3 Command procedures

Table A.10: Command procedures for the MGC

Prerequisite: A.1/MGC AND A.2/B5					
Item	Procedures	H.248 References	H.248 Status	N2/N3 Status	Support Y N n/a
J1-1	can send an Add command request and can receive an Add command reply	7.2.1	m	m	
J1-2	can send a Modify command request and can receive a Modify command reply	7.2.2	m	m	
J1-3	can send a Subtract command request and can receive a Subtract command reply	7.2.3	m	m	
J1-4	can send a Move command request and can receive a Move command reply	7.2.4	o	o	
J1-5	can send an AuditValue command request and can receive an AuditValue command reply	7.2.5	o	m	
J1-6	can send an AuditCapabilities command request and can receive an AuditCapabilities command reply	7.2.6	o	o	
J1-7	can receive a Notify command request and can send a Notify command reply	7.2.7	o	o	
J1-8	can send/receive a ServiceChange command request and receive/send a ServiceChange command reply	7.2.8	m	m	
Comments:					

Table A.11: Command procedures for the MG

Prerequisite: A.1/MG AND A.2/B.5					
Item	Procedures	H.248 References	H.248 Status	N2/N3 Status	Support Y N n/a
J2-1	can receive an Add command request and can send an Add command reply	7.2.1	m	m	
J2-2	can receive a Modify command request and can send a Modify command reply	7.2.2	m	m	
J2-3	can receive a Subtract command request and can send a Subtract command reply	7.2.3	m	m	
J2-4	can receive a Move command request and can send a Move command reply	7.2.4	o	o	
J2-5	can receive an AuditValue command request and can send an AuditValue command reply	7.2.5	o	m	
J2-6	can receive an AuditCapabilities command request and can send an AuditCapabilities command reply	7.2.6	o	o	
J2-7	can send a Notify command request and can receive a Notify command reply	7.2.7	o	o	
J2-8	can send/receive a ServiceChange command request and receive/send a ServiceChange command reply	7.2.8	m	m	
Comments:					

A.9 Protocol messages sent by the IUT

Tables of clause A.9 show the content of the H.248.1 messages. Due to the modular structure of the H.248.1 protocol the H.248.1 messages consist of a levelled structure of request and reply messages (Transaction, Context and Command level) which includes different protocol parameters, various descriptors and/or parameters defined in packages. According to this modular structure the content of a H.248.1 message can strongly vary depending on the signalling purpose. Therefore in clause A.9 the terms "mandatory" (m), "optional" (o) and "not applicable" (n/a) are used in the following meaning:

- m the element shall be included in every message/descriptor of this specific type.
- o used for elements which can be included in the message for some specific signalling purpose (and for that signalling purposes they can also be mandatory) but need not present in every message of that specific type.
- n/a element shall not be used in the messages within the TIPHON profile.

The message content tables in this clause reflect only the viewpoint of the sender of the message. The message sender shall be capable to set up messages according to the tables. The message receiver shall be capable to process all the mandatory and optional elements in the incoming message. If the receiver receives an information element which is marked as n/a the receiver shall discard the information element without any further action (e.g. without sending an error indication).

A.9.1 H.248/MEGACO message PDU

Table A.12: H.248/MEGACO message PDU

Prerequisite: A.2/B1					
Item	PDU parameters	H.248 References	H.248 Status	N2/N3 Status	Support Y N n/a
K1	support of the protocol version number	8.3 Annex A/B	m	m	
K2	support of an authentication header	10.2	c.8	c.8	
K3	support of IP4 address	Annex A/B	o.4	o.4	
K4	support of IP6 address	Annex A/B	o.4	o.4	
K5	support of a domain name	Annex A/B	o.4	n/a	
K6	support of a device name	Annex A/B	o.4	n/a	
K7	support of a mtp address	Annex A/B	o.4	n/a	
K8	support of a port number (see note)	Annex A/B	o	o	
K9	at least one Transaction	8.3 Annex A/B	o.5	o.5	
K10	error descriptor	Annex A/B 11.3	o.5	o.5	
o.4: at least one of the items					
c.8: IF (the underlying IP networks supports IPv4 but not IPsec) then m, IF (the underlying IP networks supports IPv4 and IPsec) then n/a IF (the underlying IP networks supports IPv6) then n/a IF (the underlying network is not an IP network) then n/a					
o.5: at least one of the items					
NOTE: This is a dynamically assigned port number, not the default port number					
Comments:					

A.9.2 Transactions

A.9.2.1 Transaction Request

Table A.13 Transaction Request

Prerequisite: A.2/B2					
Item	Parameters	H.248 References	H.248 Status	N2/N3 Status	Support Y N n/a
L1	Transaction ID	8.2.1	m	m	
L2	at least one Action Request	8.2.1	m	m	
Comments:					

A.9.2.2 Transaction Reply

Table A.14: Transaction Reply

Prerequisite: A.2/B2					
Item	Parameters	H.248 References	H.248 Status	N2/N3 Status	Support Y N n/a
L3	Transaction ID	8.2.2	m	m	
L4	ImmAckRequired parameter is set	8.2.2	c.9	c.9	
L5	Error Descriptor	8.2.2	o.6	o.6	
L6	at least one Action Reply	8.2.2	o.6	o.6	
c.9: IF (A.2/B13) then m, IF (A.2/B12) then o					
o.6: At least one of the items					
Comments:					

A.9.2.3 Transaction Pending

Table A.15: Transaction Pending

Prerequisite: A.2/B2					
Item	Parameters	H.248 References	H.248 Status	N2/N3 Status	Support Y N n/a
L7	Transaction ID	8.2.3	m	m	
Comments:					

A.9.2.4 Transaction ResponseAck

Table A.16: Transaction ResponseAck

Prerequisite: (A.14/L4)					
Item	Parameters	H.248 References	H.248 Status	N2/N3 Status	Support Y N n/a
L8	at least one Transaction ID for confirmation included	Annex A/B	m	m	
L9	series of Transaction IDs for confirmation included	Annex A/B	o	o	
Comments:					

A.9.3 Contexts

A.9.3.1 Action Request

Table A.17: Action Request

Prerequisite: A.2/B3					
Item	Parameters	H.248 References	H.248 Status	N2/N3 Status	Support Y N n/a
M1	Context ID (can be a wildcard Context ID)	8.1.2	m	m	
M2	Topology Descriptor	6.1.1 7.1.18	o	n/a	
M3	Emergency Descriptor	6.1.1	o	n/a	
M4	Priority Descriptor	6.1.1	o	n/a	
M5	audit request for the Context Descriptors	7.2.9	o	n/a	
M6	at least one Command Request	8	m	m	
Comments:					

A.9.3.2 Action Reply

Table A.18: Action Reply

Prerequisite: A.2/B3					
Item	Parameters	H.248 References	H.248 Status	N2/N3 Status	Support Y N n/a
M7	Context ID	8.1.2	m	m	
M8	Error Descriptor	8	m	o.7	
M9	at least one Command Reply	8	m	o.7	
M10	Topology Descriptor	6.1.1 7.1.18	o	n/a	
M11	Emergency Descriptor	6.1.1	o	n/a	
M12	Priority Descriptor	6.1.1	o	n/a	
o.7: At least one of the items					
Comments:					

A.9.4 Commands

A.9.4.1 Command Requests

A.9.4.1.1 Add Command Request

Table A.19: Add Command Request

Prerequisite: (A.1/MGC) AND (A.6/F1)					
Item	Parameters	H.248 References	H.248 Status	N2/N3 Status	Support Y N n/a
N1-1	Termination ID (can be a wildcard Termination ID)	7.2.1	m	m	
N1-2	Media Descriptor	7.2.1	o	c.10	
N1-3	Modem Descriptor	7.2.1	o	n/a	
N1-4	Mux Descriptor	7.2.1	o	n/a	
N1-5	Events Descriptor	7.2.1	o	o	
N1-6	EventBufferDescriptor	7.2.1	o	n/a	
N1-7	Signals Descriptor	7.2.1	o	n/a	
N1-8	DigitMap Descriptor	7.2.1	o	n/a	
N1-9	Audit Descriptor	7.2.1	o	o	
c.10: IF (TIPHON interface N2) then m, IF (TIPHON interface N3) then o					
Comments:					

A.9.4.1.2 Modify Command Request

Table A.20: Modify Command Request

Prerequisite: (A.1/MGC) AND (A.6/F2)					
Item	Parameters	H.248 References	H.248 Status	N2/N3 Status	Support Y N n/a
N2-1	Termination ID (wildcard CHOOSE shall not be used for the Termination ID)	7.2.2	m	m	
N2-2	Media Descriptor	7.2.2	o	m	
N2-3	Modem Descriptor	7.2.2	o	n/a	
N2-4	Mux Descriptor	7.2.2	o	n/a	
N2-5	Events Descriptor	7.2.2	o	o	
N2-6	EventBufferDescriptor	7.2.2	o	n/a	
N2-7	Signals Descriptor	7.2.2	o	n/a	
N2-8	DigitMap Descriptor	7.2.2	o	n/a	
N2-9	Audit Descriptor	7.2.2	o	o	
Comments:					

A.9.4.1.3 Substract Command Request

Table A.21: Substract Command Request

Prerequisite: (A.1/MGC) AND (A.6/F3)					
Item	Parameters	H.248 References	H.248 Status	N2/N3 Status	Support Y N n/a
N3-1	Termination ID (wildcard CHOOSE shall not be used for the Termination ID)	7.2.3	m	m	
N3-2	Audit Descriptor	7.2.3	o	o	
Comments:					

A.9.4.1.4 Move Command Request

Table A.22: Move Command Request

Prerequisite: (A.1/MGC) AND (A.6/F4)					
Item	Parameters	H.248 References	H.248 Status	N2/N3 Status	Support Y N n/a
N4-1	Termination ID (wildcard CHOOSE shall not be used for the Termination ID)	7.2.4	m	m	
N4-2	Media Descriptor	7.2.4	o	o	
N4-3	Modem Descriptor	7.2.4	o	n/a	
N4-4	Mux Descriptor	7.2.4	o	n/a	
N4-5	Events Descriptor	7.2.4	o	o	
N4-6	EventBufferDescriptor	7.2.4	o	n/a	
N4-7	Signals Descriptor	7.2.4	o	n/a	
N4-8	DigitMap Descriptor	7.2.4	o	n/a	
N4-9	Audit Descriptor	7.2.4	o	o	
Comments:					

A.9.4.1.5 AuditValue Command Request

Table A.23: Audit Command Request

Prerequisite: (A.1/MGC) AND (A.6/F5)					
Item	Parameters	H.248 References	H.248 Status	N2/N3 Status	Support Y N n/a
N5-1	Termination ID (wildcard CHOOSE shall not be used for the Termination ID)	7.2.5	m	m	
N5-2	Audit Descriptor	7.2.5	m	m	
Comments:					

A.9.4.1.6 AuditCapabilities Command Request

Table A.24: AuditCapabilities Command Request

Prerequisite: (A.1/MGC) AND (A.6/F6)					
Item	Parameters	H.248 References	H.248 Status	N2/N3 Status	Support Y N n/a
N6-1	Termination ID (wildcard CHOOSE shall not be used for the Termination ID)	7.2.6	m	m	
N6-2	Audit Descriptor	7.2.6	m	m	
Comments:					

A.9.4.1.7 Notify Command Request

Table A.25: Notify Command Request

Prerequisite: (A.1/MG) AND (A.6/F7)					
Item	Parameters	H.248 References	H.248 Status	N2/N3 Status	Support Y N n/a
N7-1	Termination ID	7.2.7	m	m	
N7-2	ObservedEvents Descriptor	7.2.7	m	m	
N7-3	Error Descriptor	7.2.7	o	o	
Comments:					

A.9.4.1.8 ServiceChange Command Request

Table A.26: ServiceChange Command Request

Prerequisite: A.6/F8					
Item	Parameters	H.248 References	H.248 Status	N2/N3 Status	Support Y N n/a
N8-1	Termination ID	7.2.8	m	m	
N8-2	ServiceChange Descriptor	7.2.8	m	m	
Comments:					

A.9.4.2 Command Replies

A.9.4.2.1 Add Command Reply

Table A.27: Add Command Reply

Prerequisite: (A.1/MG) AND (A.6/F1)					
Item	Parameters	H.248 References	H.248 Status	N2/N3 Status	Support Y N n/a
O1-1	Termination ID	7.2.1	m	m	
O1-2	Media Descriptor	7.2.1	o	o	
O1-3	Modem Descriptor	7.2.1	o	n/a	
O1-4	Mux Descriptor	7.2.1	o	n/a	
O1-5	Events Descriptor	7.2.1	o	o	
O1-6	Signals Descriptor	7.2.1	o	n/a	
O1-7	DigitMap Descriptor	7.2.1	o	n/a	
O1-8	ObservedEvents Descriptor	7.2.1	o	o	
O1-9	EventBuffer Descriptor	7.2.1	o	n/a	
O1-10	Statistics Descriptor	7.2.1	o	o	
O1-11	Packages Descriptor	7.2.1	o	n/a	
O1-12	Error Descriptor	7.2	c.11	c.11	
c.11: IF (IUT detects an error while processing the previous received Add Command Request) then m ELSE n/a					
Comments:					

A.9.4.2.2 Modify Command Reply

Table A.28: Modify Command Reply

Prerequisite: (A.1/MG) AND (A.6/F2)					
Item	Parameters	H.248 References	H.248 Status	N2/N3 Status	Support Y N n/a
O2-1	Termination ID	7.2.2	m	m	
O2-2	Media Descriptor	7.2.2	o	o	
O2-3	Modem Descriptor	7.2.2	o	n/a	
O2-4	Mux Descriptor	7.2.2	o	n/a	
O2-5	Events Descriptor	7.2.2	o	o	
O2-6	Signals Descriptor	7.2.2	o	n/a	
O2-7	DigitMap Descriptor	7.2.2	o	n/a	
O2-8	ObservedEvents Descriptor	7.2.2	o	o	
O2-9	EventBuffer Descriptor	7.2.2	o	n/a	
O2-10	Statistics Descriptor	7.2.2	o	o	
O2-11	Packages Descriptor	7.2.2	o	n/a	
O2-12	Error Descriptor	7.2	c.12	c.12	
c.12: IF (IUT detects an error while processing the previous received Modify Command Request) then m ELSE n/a					
Comments:					

A.9.4.2.3 Subtract Command Reply

Table A.29: Subtract Command Reply

Prerequisite: (A.1/MG) AND (A.6/F3)					
Item	Parameters	H.248 References	H.248 Status	N2/N3 Status	Support Y N n/a
O3-1	Termination ID	7.2.3	m	m	
O3-2	Media Descriptor	7.2.3	o	o	
O3-3	Modem Descriptor	7.2.3	o	n/a	
O3-4	Mux Descriptor	7.2.3	o	n/a	
O3-5	Events Descriptor	7.2.3	o	o	
O3-6	Signals Descriptor	7.2.3	o	n/a	
O3-7	DigitMap Descriptor	7.2.3	o	n/a	
O3-8	ObservedEvents Descriptor	7.2.3	o	o	
O3-9	EventBuffer Descriptor	7.2.3	o	n/a	
O3-10	Statistics Descriptor	7.2.3	o	m	
O3-11	Packages Descriptor	7.2.3	o	n/a	
O3-12	Error Descriptor	7.2	c.13	c.13	
c.13: IF (IUT detects an error while processing the previous received Subtract Command Request) then m ELSE n/a					
Comments:					

A.9.4.2.4 Move Command Reply

Table A.30: Move Command Reply

Prerequisite: (A.1/MG) AND (A.6/F4)					
Item	Parameters	H.248 References	H.248 Status	N2/N3 Status	Support Y N n/a
O4-1	Termination ID	7.2.4	m	m	
O4-2	Media Descriptor	7.2.4	o	o	
O4-3	Modem Descriptor	7.2.4	o	n/a	
O4-4	Mux Descriptor	7.2.4	o	n/a	
O4-5	Events Descriptor	7.2.4	o	o	
O4-6	Signals Descriptor	7.2.4	o	n/a	
O4-7	DigitMap Descriptor	7.2.4	o	n/a	
O4-8	ObservedEvents Descriptor	7.2.4	o	o	
O4-9	EventBuffer Descriptor	7.2.4	o	n/a	
O4-10	Statistics Descriptor	7.2.4	o	o	
O4-11	Packages Descriptor	7.2.4	o	n/a	
O4-12	Error Descriptor	7.2	c.14	c.14	
c.14: IF (IUT detects an error while processing the previous received Move Command Request) then m ELSE n/a					
Comments:					

A.9.4.2.5 AuditValue Command Reply

Table A.31: AuditValue Command Reply

Prerequisite: (A.1/MG) AND (A.6/F5)					
Item	Parameters	H.248 References	H.248 Status	N2/N3 Status	Support Y N n/a
O5-1	Termination ID	7.2.5	m	m	
O5-2	Media Descriptor	7.2.5	o	o	
O5-3	Modem Descriptor	7.2.5	o	n/a	
O5-4	Mux Descriptor	7.2.5	o	n/a	
O5-5	Events Descriptor	7.2.5	o	o	
O5-6	Signals Descriptor	7.2.5	o	n/a	
O5-7	DigitMap Descriptor	7.2.5	o	n/a	
O5-8	ObservedEvents Descriptor	7.2.5	o	o	
O5-9	EventBuffer Descriptor	7.2.5	o	n/a	
O5-10	Statistics Descriptor	7.2.5	o	o	
O5-11	Packages Descriptor	7.2.5	o	n/a	
O5-12	Error Descriptor	7.2	c.15	c.15	
c.15: IF (IUT detects an error while processing the previous received AuditValue Command Request) then m ELSE n/a					
Comments:					

A.9.4.2.6 AuditCapabilities Command Reply

Table A.32: AuditCapabilities Command Reply

Prerequisite: (A.1/MG) AND (A.6/F6)					
Item	Parameters	H.248 References	H.248 Status	N2/N3 Status	Support Y N n/a
O6-1	Termination ID	7.2.6	m	m	
O6-2	Media Descriptor	7.2.6	o	o	
O6-3	Modem Descriptor	7.2.6	o	n/a	
O6-4	Mux Descriptor	7.2.6	o	n/a	
O6-5	Events Descriptor	7.2.6	o	o	
O6-6	Signals Descriptor	7.2.6	o	n/a	
O6-7	ObservedEvents Descriptor	7.2.6	o	o	
O6-8	EventBuffer Descriptor	7.2.6	o	n/a	
O6-9	Statistics Descriptor	7.2.6	o	o	
O6-10	Error Descriptor	7.2	c.16	c.16	
c.16: IF (IUT detects an error while processing the previous received AuditCapabilities Command Request) then m ELSE n/a					
Comments:					

A.9.4.2.7 Notify Command Reply

Table A.33: Notify Command Reply

Prerequisite: (A.1/MGC) AND (A.6/F7)					
Item	Parameters	H.248 References	H.248 Status	N2/N3 Status	Support Y N n/a
O7-1	Termination ID	7.2.7	m	m	
O7-2	Error Descriptor	7.2	c.17	c.17	
c.17: IF (IUT detects an error while processing the previous received Notify Command Request) then m ELSE n/a					
Comments:					

A.9.4.2.8 Service Change Command Reply

Table A.34: Service Change Command Reply

Prerequisite: A.6/F8					
Item	Parameters	H.248 References	H.248 Status	N2/N3 Status	Support Y N n/a
O8-1	Termination ID	7.2.8	m	m	
O8-2	Service Change Descriptor	7.2.8	m	m	
O8-3	Error Descriptor	7.2	c.18	c.18	
c.18: IF (IUT detects an error while processing the previous received Service Change Command Request) then m ELSE n/a					
Comments:					

A.9.5 Descriptors

A.9.5.1 Media Descriptor

Table A.35: Media Descriptor

Prerequisite: A.7/G3					
Item	Description	H.248 References	H.248 Status	N2/N3 Status	Support Y N n/a
P3-1	Termination State Descriptor included	7.1.4	o.8	o.8	
P3-2	Stream Descriptor (see note) included	7.1.4	o.8	o.8	
P3-3	Local Control Descriptor included without an enclosing Stream Descriptor	7.1.4	o.8	n/a	
P3-4	Local Descriptor included without an enclosing Stream Descriptor	7.1.4	o.8	n/a	
P3-5	Remote Descriptor included without an enclosing Stream Descriptor	7.1.4	o.8	n/a	
o.8: at least one of the items shall be included within the Media Descriptor					
NOTE: If a Stream Descriptor is included in the Media Descriptor, then the Local Control, Local and Remote Descriptors shall be within the Stream descriptor.					
Comments:					

A.9.5.2 Termination State Descriptor

Table A.36: Termination State Descriptor

Prerequisite: A.7/G4 AND A.48/AN-E2					
Item	Description	H.248 References	H.248 Status	N2/N3 Status	Support Y N n/a
P4-1	includes propertyIDs according to the Base Root Package E.2.1	E.2.1	o.9	o.9	
P4-2	parameter EventBufferControl is set to value "lockstep"	7.1.9	o.9	n/a	
P4-3	parameter EventBufferControl is set to value "off"	7.1.9	o.9	o.9	
P4-4	service state parameter is set (test, out of service, in service)	7.1.5	o.9	o.9	
o.9: at least one of the items					
Comments:					

A.9.5.3 Stream Descriptor

Table A.37: Stream Descriptor

Prerequisite: A.7/G5					
Item	Description	H.248 References	H.248 Status	N2/N3 Status	Support Y N n/a
P5-1	support of Stream IDs for bi-directional media stream	7.1.6	m	m	
P5-3	Local Control Descriptor	7.1.6	o.10	o.10	
P5-4	Local Descriptor	7.1.6	o.10	o.10	
P5-5	Remote Descriptor	7.1.6	o.10	o.10	
o.10: at least one of the items					
Comments:					

A.9.5.4 Local Descriptor

Table A.38: Local Descriptor

Prerequisite: A.7/G6					
Item	Description	H.248 References	H.248 Status	N2/N3 Status	Support Y N n/a
P6-1	use of SDP protocol (RFC 2327) in case of text encoding in case of binary encoding	7.1.8	c.19	c.19	
P6-2	use of tag - value pairs (H.248.1 annex C)	7.1.8	c.20	c.20	
c.19: IF (A.2/B9) then m ELSE n/a					
c.20: IF (A.2/B8) then m ELSE n/a					
Comments:					

A.9.5.5 Remote Descriptor

Table A.39: Remote Descriptor

Prerequisite: A.7/G7					
Item	Description	H.248 References	H.248 Status	N2/N3 Status	Support Y N n/a
P7-1	use of SDP protocol (RFC 2327) in case of text encoding	7.1.8	c.21	c.21	
P7-2	use of tag - value pairs (H.248.1 annex C) in case of binary encoding	7.1.8	c.22	c.22	
c.21: IF (A.2/B9) then m ELSE n/a					
c.22: IF (A.2/B8) then m ELSE n/a					
Comments:					

A.9.5.6 Local Control Descriptor

Table A.40: Local Control Descriptor

Prerequisite: A.7/G8					
Item	Description	H.248 References	H.248 Status	N2/N3 Status	Support Y N n/a
P8-1	value for stream mode properties is set (sendOnly, recvOnly, sendRecv, inactive, loopBack)	7.1.7	o.11	o.11	
P8-2	BOOLEAN Value Reserve Group is set (TRUE/FALSE)	7.1.7	o.11	o.11	
P8-3	BOOLEAN Value Reserve Value is set (TRUE/FALSE)	7.1.7	o.11	o.11	
P8-4	includes propertyIDs according to Network Package E.11.1	E.11.1	o.11	o.11	
P8-5	includes propertyIDs according to TDM Circuit Package E.13.1	E.13.1	o.11	o.11	
o.11: at least one of the items					
Comments:					

A.9.5.7 ServiceChange Descriptor

Table A.41: ServiceChange Descriptor

Prerequisite: A.7/G15					
Item	Description	H.248 References	H.248 Status	N2/N3 Status	Support Y N n/a
P15-1	service change method parameter included (graceful, forced, disconnected, handoff, failover)	7.2.8	c.23	c.23	
P15-2	service change address information included	7.2.8	o	o	
P15-3	service change version parameter included	7.2.8	o	o	
P15-4	service change profile included	7.2.8	o	o	
P15-5	service change reason included (IANA registered alphanumeric token)	7.2.8	c.23	c.23	
P15-6	service change delay value included	7.2.8	c.23	c.23	
P15-7	service change MGC ID address included	7.2.8	o	o	
P15-8	time stamp included	7.2.8	o	o	
P15-9	non-standard data included	7.2.8	c.23	c.23	
P15-10	service change info included		o	n/a	
c.23: IF (A.26/N8-2) then m, IF (A.34/O8-2) then x					
Comments:					

Table A.42: Void

A.9.5.8 Statistics Descriptor

Table A.43: Statistic Descriptor

Prerequisite: A.7/G17					
Item	Description	H.248 References	H.248 Status	N2/N3 Status	Support Y N n/a
P17-1	includes statistic values according to the StatisticsIDs in the Network Package E.11.4	E.11.4	o.12	o.12	
P17-2	includes statistic values according to the StatisticsIDs in the RTP Package E.12.4	E.12.4	o.12	o.12	
o.12: at least one of the items					
Comments:					

A.9.5.9 Error Descriptor

Table A.44: Error Descriptor

Prerequisite: A.7/G18					
Item	Description	H.248 References	H.248 Status	N2/N3 Status	Support Y N n/a
P18-1	includes (a subset of) error codes according to annex L	Annex L	m	m	
Comments:					

A.10 Support of annexes/Packages

Mandatory elements in subsequent tables of clause A.10 shall be implemented whereas elements marked as optional are real implementation options. Elements marked as n/a shall not be used within the TIPHON release 3 profile.

A.10.1 Annex C: Tags for Media Stream Properties

Table A.45: Support of H.248.1 annex C

Prerequisite: A.2/B8					
Item	Description	H.248.1 References	H.248 Status	N2/N3 Status	Support Y N n/a
AN-C1	support of tags for general media attributes - Transmission mode - Sampling rate - Bitrate - Samplepp - Silencesupp - Jitterbuff - PropDelay - RTPpayload (see note)	C.1	o	m m m m m m m	
AN-C2	support of tags for MUX properties	C.2	o	n/a	
AN-C3	support of tags for general bearer properties	C.3	o	n/a	
AN-C4	support of tags for general ATM properties	C.4	o	n/a	
AN-C5	support of tags for frame relay	C.5	o	n/a	
AN-C6	support of tags for IP	C.6	o	m	
AN-C7	support of tags for ATM AAL2	C.7	o	n/a	
AN-C8	support of tags for ATM AAL1	C.8	o	n/a	
AN-C9	support of tags for bearer capabilities - TMR (see note 6)	C.9	o	m	
AN-C10	support of tags for AAL5 properties	C.10	o	n/a	
AN-C11	support of tags for SDP equivalents	C.11	o	n/a	
AN-C12	support of tags for H.245	C.12	o	n/a	
NOTE: All other elements are optional.					
Comments:					

A.10.2 Annex D: Transport over IP

A.10.2.1 Transport over IP/UDP

Table A.46: Support of H.248.1 annex D.1

Prerequisite: A.2/B13					
Item	Description	H.248.1 References	H.248 Status	N2/N3 Status	Support Y N n/a
AN-D1	providing an 'at-most-once' functionality	D.1.1	m	m	
AN-D2	support of the LONG-TIMER	D.1.1	m	m	
AN-D3	support of the three-way handshake mechanism	D.1.2.2	m	m	
AN-D4	use of immAckRquired parameter in the final response (Transaction reply) in case of sending provisional responses (Transaction pending) before	D.1.4	m	m	
Comments:					

A.10.2.2 Transport over IP/TCP

Table A.47: Support of H.248.1 annex D.2

Prerequisite: A.2/B12					
Item	Description	H.248.1 References	H.248 Status	N2/N3 Status	Support Y N n/a
AN-D5	providing an 'at-most-once" functionality	D.2.1	o	o	
AN-D6	support of the LONG-TIMER	D.2.1	o	o	
AN-D7	support of the three-way handshake mechanism	D.2.2	o	o	
Comments:					

A.10.3 Annex E: Basic Packages

Table A.48: Support of H.248.1 annex E

Item	Description	H.248.1 References	H.248 Status	N2/N3 Status	Support Y N n/a
AN-E1	support of Generic Package	E.1	o	m	
AN-E2	support of Base Root Package	E.2	o	m	
AN-E3	support of Tone Generator Package	E.3	o	n/a	
AN-E4	support of Tone Detection Package	E.4	o	n/a	
AN-E5	support of Basic DTMF Generator Package	E.5	o	n/a	
AN-E6	support of DTMF Detection Package	E.6	o	n/a	
AN-E7	support of Call Progress Tones Generator Package	E.7	o	n/a	
AN-E8	support of Call Progress Tone Detection Package	E.8	o	n/a	
AN-E9	support of Analog Line Supervision Package	E.9	o	n/a	
AN-E10	support of Basic Continuity Package	E.10	o	n/a	
AN-E11	support of Network Package	E.11	o	m	
AN-E12	support of RTP Package	E.12	o	m	
AN-E13	support of TDM Circuit Package	E.13	o	c.25	
c.25: IF (TIPHON interface N2) then n/a, IF (TIPHON interface N3) then m					
Comments:					

A.10.4 Annex L: Error Code descriptions

Table A.49: Support of H.248.1 annex L

Item	Description	H.248.1 References	H.248 Status	N2/N3 Status	Support Y N n/a
AN-L1	support of error code description	7.3	o	o	
AN-L2	support of error code 411 (The transaction refers to an unknown ContextID)	L.5.2.7	o	m	
AN-L3	support of error code 412 (No ContextIDs available)	L.5.2.8	o	m	
AN-L4	support of error code 430 (Unknown TerminationID)	L.5.2.11	o	m	
AN-L5	support of error code 432 (Out of TerminationIDs or No TerminationID available)	L.5.2.13	o	m	
AN-L6	support of error code 433 (TerminationID is already in a Context)	L.5.2.14	o	m	
AN-L7	support of error code 444 (Unsupported or Unknown Descriptor)	L.5.2.21	o	m	
AN-L8	support of error code 445 (Unsupported or Unknown Property)	L.5.2.22	o	m	
AN-L9	support of error code 510 (Insufficient resources)	L.5.2.41	o	m	
AN-L10	support of error code 515 (Unsupported Media Type)	L.5.2.45	o	m	
AN-L11	support of error code 526 (Insufficient bandwidth)	L.5.2.51	o	m	
AN-L12	support of error code 505 (Transaction Request Received before a ServiceChange Reply has been received)	L.5.2.40	o	m	
AN-L13	support of error code 406 (Version Not Supported)	L.5.2.5	o	m	
AN-L14	support of error code 401 (Protocol error)	L.5.2.2	o	m	
NOTE: All other error codes of annex L are optional.					
Comments:					

A.10.5 Additional annexes and Packages

Table A.50: Additional annexes and Packages

Item	Description	H.248.1 References	H.248 Status	N2/N3 Status	Support Y N n/a
AN-F	Text conversation and fax packages	Annex F	o	n/a	
AN-G	User Interface elements and Actions packages	Annex G	o	n/a	
AN-H	SCTP Transport	Annex H	o	n/a	
AN-I	ATM Transport	Annex I	o	n/a	
AN-J	Dynamic Tone definition Package	Annex J	o	n/a	
AN-K	Generic Announcement Package	Annex K	o	n/a	
AN-M	Advanced Audio server package	Annex M	o	n/a	
Comments:					

A.11 Timers and Parameters

A.11.1 Timers

Table A.51: Supported timers

Prerequisite:					
Item	Parameters	H.248 References	H.248 Status	N2/N3 Status	Value (ms) (see note)
Q1	Transaction Timer	7.2.1	c.26	m	
Q2	LONG TIMER	Annex D	c.27	m	
Q3	normalMGExecutionTime	E.2.1	c.28	m	
Q4	normalMGCEExecutionTime	E.2.1	c.28	m	
Q5	MGProvisionalResponseTimerValue	E.2.1	c.28	m	
Q6	MGCPProvisionalResponseTimerValue	E.2.1	c.28	m	
Q7	Maximum Jitter Buffer	E.11.1	c.29	m	
c.26: IF (A.3/C5) then m ELSE n/a c.27: IF (A.54/AN-D2) then m ELSE n/a c.28: IF (A.56/AN-E2) then m ELSE n/a c.29: IF (A.56/AN-E11) then m ELSE n/a NOTE: This is the default value in case of re-writable parameters.					
Comments:					

A.11.2 IUT Parameters

Table A.52: Supported parameters

Prerequisite:					
Item	Parameters	H.248 References	H.248 Status	N2/N3 Status	Value (see note)
R1	MaxNrOfContexts (1 and up)	E.2.1	c.30	m	
R2	MaxTerminationsPerContext	E.2.1	c.30	m	
R3	MGCOriginatedPendingLimit	E.2.1	c.30	m	
R4	MGCOriginatedPendingLimit	E.2.1	c.30	m	
R5	Echo cancellation	E.13.1	c.31	m	
R6	Gain Control	E.13.1	c.31	m	
c.30: IF (A.56/AN-E2) then m ELSE n/a c.31: IF (A.56/AN-E13) then m ELSE n/a NOTE: This is the default value in case of re-writable parameters.					
Comments:					

A.12 Support of specific procedures for the TIPHON interfaces according to the TIPHON release 3 profile

Mandatory elements in subsequent tables of clause A.12 shall be implemented whereas elements marked as optional are real implementation options. Elements marked as n/a shall not be used within the TIPHON release 3 profile.

A.12.1 Specific PICS for TIPHON interface N2 according to TS 101 885

Table A.53: Support of TIPHON interface N2

Item	Description	TS 101 885 References	N2 Status	Support Y N n/a
S-1	support of error handling according to TS 101 885	4.3	m	
S-2	support of default TIPHON media setup procedures without source filtering	7.3	m	
S-3	support of default TIPHON media setup procedures with source filtering	7.4	o	
S-4	support of the media activation option procedure	8.1	o	
S-5	support of the Code point mapping of protocol primitives	A1.1	m	
S-6	support of the binary encoding mapping table	A.1.2	c.32	
S-7	support of the text encoding mapping table	A.1.3	c.33	
S-8	support of the error values as specified in TS 101 885	A.2	m	
c.32:	IF (A.2/B.8) then m ELSE n/a			
c.33:	IF (A.2/B.9) then m ELSE n/a			
Comments:				

A.12.2 Specific PICS for TIPHON interface N3 according to TS 101 885

Table A.54: Support of TIPHON interface N3

Item	Description	TS 101 885 References	N3 Status	Support Y N n/a
T-1	support of error handling according to TS 101 885	4.3	m	
T-2	support of default TIPHON media setup procedures without source filtering	7.5 7.6	m	
T-3	support of default TIPHON media setup procedures with source filtering	7.4	n/a	
T-4	support of the media activation option procedure	8.1	o	
T-5	support of the Code point mapping of protocol primitives	A1.1	m	
T-6	support of the binary encoding mapping table	A.1.2	c.34	
T-7	support of the text encoding mapping table	A.1.3	c.35	
T-8	support of the error values as specified in TS 101 885	A.2	m	
c.34:	IF (A.2/B.8) then m ELSE n/a			
c.35:	IF (A.2/B.9) then m ELSE n/a			
Comments:				

History

Document history		
V1.1.1	August 2002	Publication