

ETSI TS 101 570-5 V1.2.1 (2020-02)



Interoperability Testing for Maritime Digital Selective Calling (DSC) Radios; Part 5: VHF Class H Test Descriptions

ReferenceRTS/ERM-TGMAR-541-5

KeywordsDSC, interoperability, maritime, TSS&TP

ETSI

650 Route des Lucioles
F-06921 Sophia Antipolis Cedex - FRANCE

Tel.: +33 4 92 94 42 00 Fax: +33 4 93 65 47 16

Siret N° 348 623 562 00017 - NAF 742 C
Association à but non lucratif enregistrée à la
Sous-Préfecture de Grasse (06) N° 7803/88

Important notice

The present document can be downloaded from:

<http://www.etsi.org/standards-search>

The present document may be made available in electronic versions and/or in print. The content of any electronic and/or print versions of the present document shall not be modified without the prior written authorization of ETSI. In case of any existing or perceived difference in contents between such versions and/or in print, the prevailing version of an ETSI deliverable is the one made publicly available in PDF format at www.etsi.org/deliver.

Users of the present document should be aware that the document may be subject to revision or change of status.

Information on the current status of this and other ETSI documents is available at

<https://portal.etsi.org/TB/ETSIDeliverableStatus.aspx>

If you find errors in the present document, please send your comment to one of the following services:

<https://portal.etsi.org/People/CommiteeSupportStaff.aspx>

Copyright Notification

No part may be reproduced or utilized in any form or by any means, electronic or mechanical, including photocopying and microfilm except as authorized by written permission of ETSI.

The content of the PDF version shall not be modified without the written authorization of ETSI.

The copyright and the foregoing restriction extend to reproduction in all media.

© ETSI 2020.

All rights reserved.

DECT™, **PLUGTESTS™**, **UMTS™** and the ETSI logo are trademarks of ETSI registered for the benefit of its Members.

3GPP™ and **LTE™** are trademarks of ETSI registered for the benefit of its Members and of the 3GPP Organizational Partners.

oneM2M™ logo is a trademark of ETSI registered for the benefit of its Members and of the oneM2M Partners.

GSM® and the GSM logo are trademarks registered and owned by the GSM Association.

Contents

Intellectual Property Rights	4
Foreword.....	4
Modal verbs terminology.....	4
1 Scope	5
2 References	5
2.1 Normative references	5
2.2 Informative references.....	5
3 Definition of terms, symbols and abbreviations.....	5
3.1 Terms.....	5
3.2 Symbols.....	6
3.3 Abbreviations	6
4 Test configurations.....	6
5 Test Suite Structure (TSS).....	8
6 Test Descriptions (TD).....	9
6.1 Individual Calls	9
6.2 Group Calls	13
6.3 All Ships Calls.....	14
6.4 Sending Distress Alerts	15
6.4.0 General Operation.....	15
6.4.1 Distress alert sending priority	19
6.4.2 Ongoing distress alert priority	21
6.4.3 Manual termination after distress alert acknowledgement.....	24
6.5 Receiving Distress Alerts	29
6.6 Receiving Distress Alert from MOB devices	32
6.6.1 Open loop MOB distress alert.....	32
6.7 Non Distress automated procedures	33
6.7.1 Call prioritization.....	33
6.7.1.1 Non-DSC calls	33
6.7.1.2 Individual routine calls.....	35
6.7.1.3 Individual Safety calls.....	37
6.7.1.4 All Ships Safety calls	39
6.7.1.5 Individual Urgency calls	41
6.7.1.6 All Ships Urgency calls.....	42
6.7.1.7 All Ships distress calls	44
6.7.2 Automated procedure tests.....	46
6.7.3 Timeout tests.....	48
6.8 Other calls	50
6.9 Interface and other functions.....	51
6.9.0 Display	51
6.9.1 Alarms in standby mode	51
6.9.2 Alarms when busy	58
6.9.3 Standby mode interface functions.....	60
Annex A (informative): Bibliography.....	63
History	64

Intellectual Property Rights

Essential patents

IPRs essential or potentially essential to normative deliverables may have been declared to ETSI. The information pertaining to these essential IPRs, if any, is publicly available for **ETSI members and non-members**, and can be found in ETSI SR 000 314: "*Intellectual Property Rights (IPRs); Essential, or potentially Essential, IPRs notified to ETSI in respect of ETSI standards*", which is available from the ETSI Secretariat. Latest updates are available on the ETSI Web server (<https://ipr.etsi.org/>).

Pursuant to the ETSI IPR Policy, no investigation, including IPR searches, has been carried out by ETSI. No guarantee can be given as to the existence of other IPRs not referenced in ETSI SR 000 314 (or the updates on the ETSI Web server) which are, or may be, or may become, essential to the present document.

Trademarks

The present document may include trademarks and/or tradenames which are asserted and/or registered by their owners. ETSI claims no ownership of these except for any which are indicated as being the property of ETSI, and conveys no right to use or reproduce any trademark and/or tradename. Mention of those trademarks in the present document does not constitute an endorsement by ETSI of products, services or organizations associated with those trademarks.

Foreword

This Technical Specification (TS) has been produced by ETSI Technical Committee Electromagnetic compatibility and Radio spectrum Matters (ERM).

The present document is part 5 of a multi-part deliverable. Full details of the entire series can be found in part 1 [i.1].

Modal verbs terminology

In the present document "**shall**", "**shall not**", "**should**", "**should not**", "**may**", "**need not**", "**will**", "**will not**", "**can**" and "**cannot**" are to be interpreted as described in clause 3.2 of the [ETSI Drafting Rules](#) (Verbal forms for the expression of provisions).

"**must**" and "**must not**" are **NOT** allowed in ETSI deliverables except when used in direct citation.

1 Scope

The present document contains the Test Descriptions (TD) for interoperability testing of the handheld class H DSC radio equipment.

2 References

2.1 Normative references

References are either specific (identified by date of publication and/or edition number or version number) or non-specific. For specific references, only the cited version applies. For non-specific references, the latest version of the referenced document (including any amendments) applies.

Referenced documents which are not found to be publicly available in the expected location might be found at <https://docbox.etsi.org/Reference>.

NOTE: While any hyperlinks included in this clause were valid at the time of publication, ETSI cannot guarantee their long term validity.

The following referenced documents are necessary for the application of the present document.

- [1] ETSI EN 300 338-5: "Technical characteristics and methods of measurement for equipment for generation, transmission and reception of Digital Selective Calling (DSC) in the maritime MF, MF/HF and/or VHF mobile service; Part 5: Handheld VHF Class H DSC".
- [2] Recommendation ITU-R M.585-8: "Assignment and use of identities in the maritime mobile service".

2.2 Informative references

References are either specific (identified by date of publication and/or edition number or version number) or non-specific. For specific references, only the cited version applies. For non-specific references, the latest version of the referenced document (including any amendments) applies.

NOTE: While any hyperlinks included in this clause were valid at the time of publication, ETSI cannot guarantee their long term validity.

The following referenced documents are not necessary for the application of the present document but they assist the user with regard to a particular subject area.

- [i.1] ETSI TS 101 570-1: "Electromagnetic compatibility and Radio spectrum Matters (ERM); Interoperability Testing for Maritime Digital Selective Calling (DSC) Radios; Part 1: Requirements catalogue".
- [i.2] ETSI EN 300 338-1: "Technical characteristics and methods of measurement for equipment for generation, transmission and reception of Digital Selective Calling (DSC) in the maritime MF, MF/HF and/or VHF mobile service; Part 1: Common requirements".

3 Definition of terms, symbols and abbreviations

3.1 Terms

For the purposes of the present document, the following terms apply:

class M: specific class of DSC functionality for use by man overboard devices

closed loop: class M individual transmission to own vessel

open loop: class M transmitting to all ships (broadcast) 'using All ships call types'

3.2 Symbols

Void.

3.3 Abbreviations

For the purposes of the present document, the abbreviations given in ETSI EN 300 338-1 [i.2] and the following apply:

CF	(Test) ConFfiguration
EUT	Equipment Under Test
MOB	Man OverBoard
TD	Test Description
TP	Test Purpose
TSS	Test Suite Structure

4 Test configurations

This clause defines all test configurations used. Each test description refers to one or multiple test configurations. It is assumed that the initial state of all the equipment involved in the test configuration is 'standby' for DSC radios or 'deactivated' for MOB devices, i.e. unless stated otherwise the pre-test conditions of each test description assume standby mode for the equipment.

An arrow connection between devices indicates that these devices are in communication range, i.e. in CF_6 EUT, QE1 and QE2 are all in the same communication range. However, QE3 is only in communication range with QE2.

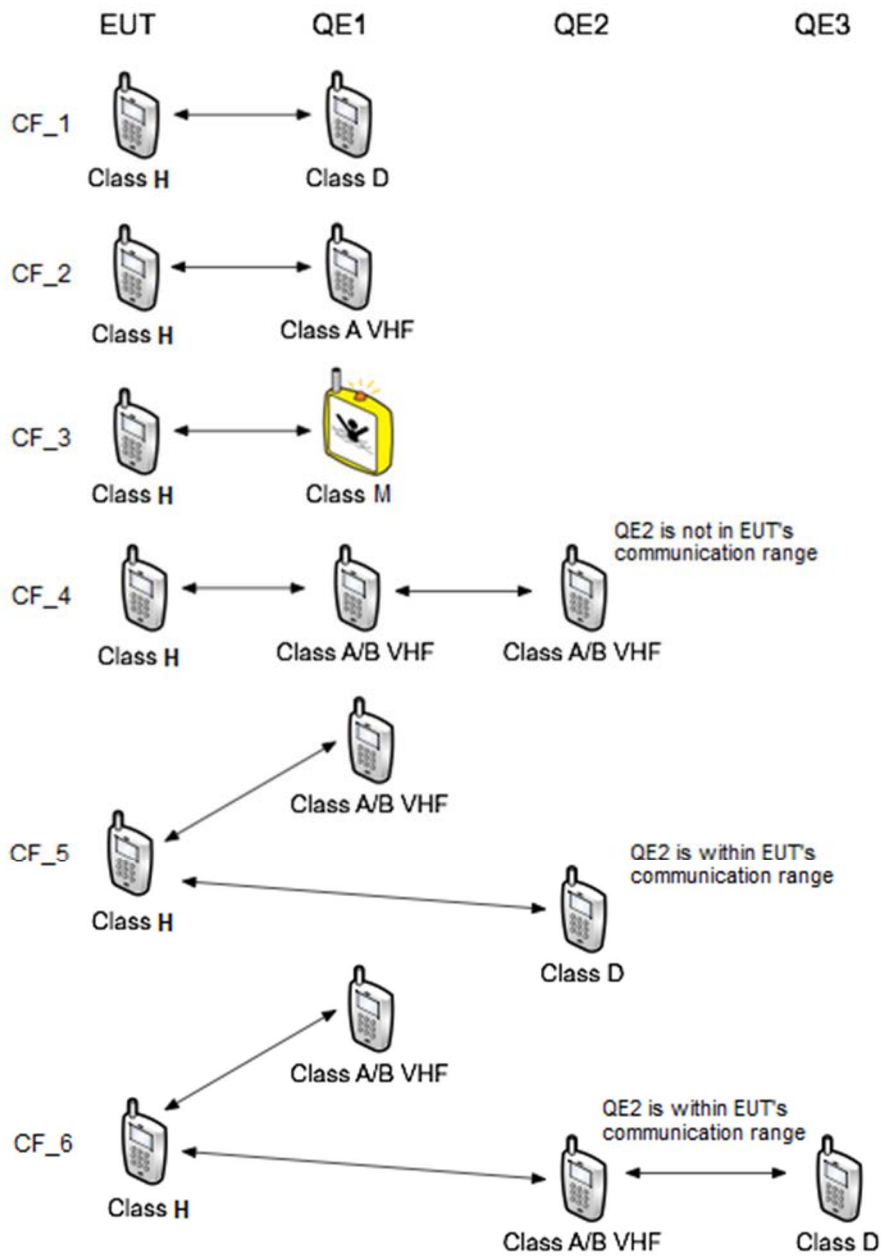

Figure 1: Configurations for Handheld Class D EUT

5 Test Suite Structure (TSS)

The following table shows the Test Suite Structure contained in the present document.

Test Group	Test Sub-Group (sub-group ID)
VHF	Individual Calls (IC)
	Group Calls (GC)
	All Ships Calls (ASC)
	Sending Distress Alerts (SDA)
	Receiving Distress Alerts (RDA)
	Non Distress Automated Procedures (NDAP)
	Other Calls (OC)
Interface and other functions (IOF)	General test (GEN)
	Alarms in standby mode (ASM)
	Alarms when busy (AWB)
	Standby mode interface functions (SMIF)

Each test description is described through a tabular format conforming to the following convention:

Interoperability Test Description			
Identifier:	A unique identifier. The test description identifiers are conforming to the TD_DSC_<GR>_<SGR>_<SN> naming convention, where: <GR> is the Test Group ID (VHF/MFHF) <SGR> is the Test Sub-Group ID <SN> is the sequential number within the test sub-group		
Summary:	Short description of the test objective		
Configuration:	The relevant test configuration, referencing the test set configurations shown in figure 1		
References:	The reference indicates the clauses of the base standard specifications in which the related interoperability requirement is expressed		
Pre-test conditions:	Defines in which initial state the test equipment has to be to apply the actual test description		
Step	Test Sequence	Verdict	
		Pass	Fail
1	The description of the individual condition to verify or action to perform	Yes/No criteria of the outcome of this verification step (if applicable)	Yes/No criteria of the outcome of this verification step (if applicable)
2	...		
Final verdict:			

6 Test Descriptions (TD)

6.1 Individual Calls

Interoperability Test Description			
Identifier:	TD_DSC_VHF_IC_0001		
Summary:	'Sending Individual call - Routine'		
Configuration:	CF_1		
References:	ETSI EN 300 338-5 [1], clauses 5.2.2 and 6.6.1		
Pre-test conditions:	QE1 and EUT in standby on CH:16 QE1 programmed with an individual MMSI		
Step	Test Sequence	Verdict	
		Pass	Fail
1	On EUT select 'Call' then select 'Individual - Routine'		
2	Enter/select MMSI of QE1		
3	Verify that menu proposes an Inter-ship Channel	Yes	No
4	Verify if the proposed channel can be changed	Yes	No
5	Cause EUT to send the individual call to QE1		
6	Verify that QE1 receives the call	Yes	No
7	Verify that EUT is still on CH:16	Yes	No
8	Cause QE1 to send ACK to EUT		
9	Verify that EUT switches to the selected channel in step 4	Yes	No
10	Verify voice communication on this channel	Yes	No
Final verdict:			

Interoperability Test Description			
Identifier:	TD_DSC_VHF_IC_0002		
Summary:	'Sending Individual call with NACK - Routine'		
Configuration:	CF_1		
References:	ETSI EN 300 338-5 [1], clauses 5.2.2 and 6.6.1		
Pre-test conditions:	QE1 and EUT in standby on CH:16 QE1 programmed with an individual MMSI		
Step	Test Sequence	Verdict	
		Pass	Fail
1	On EUT select 'Call' then select 'Individual - Routine'		
2	Enter/select MMSI of QE1		
3	Verify that menu proposes an Inter-ship Channel	Yes	No
4	Verify if the proposed channel can be changed	Yes	No
5	Cause EUT to send the individual call to QE1		
6	Verify that QE1 receives the call	Yes	No
7	Verify that EUT is still on CH:16	Yes	No
8	Cause QE1 to send NACK to EUT		
9	Verify that EUT does not switch to the selected channel in step 4	Yes	No
10	Verify that EUT indicates 'call failed' or similar	Yes	No
Final verdict:			

Interoperability Test Description			
Identifier:	TD_DSC_VHF_IC_0003		
Summary:	'Sending Individual call to a coast station - Routine'		
Configuration:	CF_2		
References:	ETSI EN 300 338-5 [1], clauses 5.2.2 and 6.6.1		
Pre-test conditions:	QE1 and EUT in standby on CH:16 QE1 programmed with a Coast Station MMSI		
Step	Test Sequence	Verdict	
		Pass	Fail
1	On EUT select 'Call' then select 'Individual - Routine'		
2	Enter/select MMSI of QE1		
3	Verify that menu does not propose a working channel	Yes	No
Final verdict:			

Interoperability Test Description			
Identifier:	TD_DSC_VHF_IC_0008		
Summary:	'Receiving Individual call - Routine'		
Configuration:	CF_2		
References:	ETSI EN 300 338-5 [1], clauses 5.2.2 and 6.7.1		
Pre-test conditions:	QE1 and EUT in standby on CH:16 EUT programmed with an individual MMSI		
Step	Test Sequence	Verdict	
		Pass	Fail
1	On QE1 select 'Call' then select 'Individual - Routine'		
2	Enter/select MMSI of EUT		
3	Set the proposed channel to CH:72		
4	Cause QE1 to send the individual call to EUT		
5	Verify that EUT receives the call and displays the proposed channel	Yes	No
6	Verify that EUT displays the MMSI of QE1	Yes	No
7	Verify that EUT is still on CH:16	Yes	No
8	Cause EUT to send ACK to QE1		
9	Verify that EUT switches to CH:72	Yes	No
10	Verify voice communication on this channel	Yes	No
Final verdict:			

Interoperability Test Description			
Identifier:	TD_DSC_VHF_IC_0009		
Summary:	'Receiving Individual call with NACK - Routine'		
Configuration:	CF_2		
References:	ETSI EN 300 338-5 [1], clauses 5.2.2 and 6.7.1		
Pre-test conditions:	QE1 and EUT in standby on CH:16 EUT programmed with an individual MMSI		
Step	Test Sequence	Verdict	
		Pass	Fail
1	On QE1 select 'Call' then select 'Individual - Routine'		
2	Enter/select MMSI of EUT		
3	Set the proposed channel to CH:72		
4	Cause QE1 to send the individual call to EUT		
5	Verify that EUT receives the call and displays the proposed channel	Yes	No
6	Verify that EUT displays the MMSI of QE1	Yes	No
7	Verify that EUT is still on CH:16	Yes	No
8	Cause EUT to send NACK to QE1		
9	Verify that EUT is still on CH:16	Yes	No
Final verdict:			

Interoperability Test Description			
Identifier:	TD_DSC_VHF_IC_0010		
Summary:	'Receiving Individual call when busy - Routine'		
Configuration:	CF_2		
References:	ETSI EN 300 338-5 [1], clauses 5.2.2 and 6.7.1		
Pre-test conditions:	QE1 and EUT in individual call on CH:72 QE2 programmed with an individual MMSI of EUT		
Step	Test Sequence	Verdict	
		Pass	Fail
1	On QE2 select 'Call' then select 'Individual - Routine'		
2	Enter/select MMSI of EUT		
3	Cause QE2 to send the individual call to EUT		
4	Verify that EUT sounds a self-terminating alarm	Yes	No
5	Verify that EUT is still on CH:72	Yes	No
6	Cause EUT to terminate the individual call		
7	Verify that EUT displays 'unread messages'	Yes	No
8	On EUT select 'Call' then 'Received Calls' and Verify that the call from QE2 is logged	Yes	No
Final verdict:			

Interoperability Test Description			
Identifier:	TD_DSC_VHF_IC_0011		
Summary:	'Receiving Individual call - Urgency'		
Configuration:	CF_2		
References:	ETSI EN 300 338-5 [1], clauses 5.2.2 and 6.7.1		
Pre-test conditions:	QE1 and EUT in standby on CH:16 EUT programmed with an individual MMSI		
Step	Test Sequence	Verdict	
		Pass	Fail
1	On QE1 select 'Call' then select 'Individual - Urgency'		
2	Enter/select MMSI of EUT		
3	Set the proposed channel to CH:72		
4	Cause QE1 to send the individual call to EUT		
5	Verify that EUT receives the call and displays the proposed channel	Yes	No
6	Verify that EUT sounds the Urgency alarm	Yes	No
7	Verify that EUT displays the MMSI of QE1	Yes	No
8	Verify that EUT is still on CH:16	Yes	No
9	Cause EUT to send ACK to QE1		
10	Verify that EUT switches to CH:72	Yes	No
11	Verify voice communication on this channel	Yes	No
Final verdict:			

Interoperability Test Description			
Identifier:	TD_DSC_VHF_IC_0012		
Summary:	'Receiving Individual call with NACK - Urgency'		
Configuration:	CF_2		
References:	ETSI EN 300 338-5 [1], clauses 5.2.2 and 6.7.1		
Pre-test conditions:	QE1 and EUT in standby on CH:16 EUT programmed with an individual MMSI		
Step	Test Sequence	Verdict	
		Pass	Fail
1	On QE1 select 'Call' then select 'Individual - Urgency'		
2	Enter/select MMSI of EUT		
3	Set the proposed channel to CH:72		
4	Cause QE1 to send the individual call to EUT		
5	Verify that EUT receives the call and displays the proposed channel	Yes	No
6	Verify that EUT sounds the Urgency alarm	Yes	No
7	Verify that EUT displays the MMSI of QE1	Yes	No
8	Verify that EUT is still on CH:16	Yes	No
9	Cause EUT to send NACK to QE1		
10	Verify that EUT returns to standby on CH:16	Yes	No
Final verdict:			

Interoperability Test Description			
Identifier:	TD_DSC_VHF_IC_0013		
Summary:	'Receiving Individual call - Safety'		
Configuration:	CF_2		
References:	ETSI EN 300 338-5 [1], clauses 5.2.2 and 6.7.1		
Pre-test conditions:	QE1 and EUT in standby on CH:16 EUT programmed with an individual MMSI		
Step	Test Sequence	Verdict	
		Pass	Fail
1	On QE1 select 'Call' then select 'Individual - Safety'		
2	Enter/select MMSI of EUT		
3	Set the proposed channel to CH:72		
4	Cause QE1 to send the individual call to EUT		
5	Verify that EUT receives the call, sounds the Safety alarm and displays the proposed channel	Yes	No
6	Verify that EUT displays the MMSI of QE1	Yes	No
7	Verify that EUT is still on CH:16	Yes	No
8	Cause EUT to send ACK to QE1		
9	Verify that EUT switches to CH:72	Yes	No
10	Verify voice communication on this channel	Yes	No
Final verdict:			

Interoperability Test Description			
Identifier:	TD_DSC_VHF_IC_0014		
Summary:	'Receiving Individual call with NACK - Safety'		
Configuration:	CF_2		
References:	ETSI EN 300 338-5 [1], clauses 5.2.2 and 6.7.1		
Pre-test conditions:	QE1 and EUT in standby on CH:16 EUT programmed with an individual MMSI		
Step	Test Sequence	Verdict	
		Pass	Fail
1	On QE1 select 'Call' then select 'Individual - Safety'		
2	Enter/select MMSI of EUT		
3	Set the proposed channel to CH:72		
4	Cause QE1 to send the individual call to EUT		
5	Verify that EUT receives the call and displays the proposed channel	Yes	No
6	Verify that EUT sounds the Safety alarm	Yes	No
7	Verify that EUT displays the MMSI of QE1	Yes	No
8	Verify that EUT is still on CH:16	Yes	No
9	Cause EUT to send NACK to QE1		
10	Verify that EUT returns to standby on CH:16	Yes	No
Final verdict:			

Interoperability Test Description			
Identifier:	TD_DSC_VHF_IC_0015		
Summary:	'Sending Individual call on a Distress channel'		
Configuration:	CF_2		
References:	ETSI EN 300 338-5 [1], clauses 5.2.2 and 6.6.1		
Pre-test conditions:	QE1 and EUT in standby on CH:16 QE1 programmed with an individual MMSI		
Step	Test Sequence	Verdict	
		Pass	Fail
1	On EUT select 'Call' then select 'Individual - Routine'		
2	Enter/select MMSI of QE1		
3	Verify that menu proposes an Inter-ship Channel	Yes	No
4	Enter a distress channel as working channel		
5	Cause EUT to send the individual call to QE1		
6	Verify that EUT does not send the call and indicates a channel selection error	Yes	No
Final verdict:			

6.2 Group Calls

Interoperability Test Description			
Identifier:	TD_DSC_VHF_GC_0001		
Summary:	'Sending group call - Routine'		
Configuration:	CF_2		
References:	ETSI EN 300 338-5 [1], clause 6.6.1		
Pre-test conditions:	QE1 and EUT in standby on CH:16 QE1 programmed with a group MMSI		
Step	Test Sequence	Verdict	
		Pass	Fail
1	On EUT select 'Call' then select 'Group'		
2	Enter/select group MMSI of QE1		
3	Verify that menu proposes an Inter-ship Channel	Yes	No
4	Verify if the proposed channel can be changed	Yes	No
5	Cause EUT to send the group call to QE1		
6	Verify that QE1 receives the call	Yes	No
7	Verify that EUT switches to the selected channel in step 4	Yes	No
8	Verify voice communication on this channel	Yes	No
Final verdict:			

Interoperability Test Description			
Identifier:	TD_DSC_VHF_GC_0002		
Summary:	'Receiving group call - Routine'		
Configuration:	CF_2		
References:	ETSI EN 300 338-5 [1], clause 6.7.1		
Pre-test conditions:	QE1 and EUT in standby on CH:16 EUT programmed with an group MMSI		
Step	Test Sequence	Verdict	
		Pass	Fail
1	On QE1 select 'Call' then select 'Group'		
2	Enter/select group MMSI of EUT		
3	Set the proposed channel to CH:72		
4	Cause QE1 to send the group call to EUT		
5	Verify that EUT receives the call and displays the proposed channel	Yes	No
6	Verify that EUT displays the MMSI of QE1	Yes	No
7	Verify that EUT switches to CH:72	Yes	No
8	Verify voice communication on this channel	Yes	No
Final verdict:			

Interoperability Test Description			
Identifier:	TD_DSC_VHF_GC_0003		
Summary:	'Receiving Group call when busy - Routine'		
Configuration:	CF_2		
References:	ETSI EN 300 338-5 [1], clause 6.7.1		
Pre-test conditions:	QE1 and EUT in group call on CH:72 QE2 programmed with an individual MMSI of EUT		
Step	Test Sequence	Verdict	
		Pass	Fail
1	On QE2 select 'Call' then select 'Individual - Routine'		
2	Enter/select group MMSI of EUT		
3	Cause QE2 to send the individual call to EUT		
4	Verify that EUT sounds a self-terminating alarm	Yes	No
5	Verify that EUT is still on CH:72	Yes	No
6	Cause EUT to terminate the individual call		
7	Verify that EUT displays 'unread messages'	Yes	No
8	On EUT select 'Call' then 'Received Calls' and Verify that the call from QE2 is logged	Yes	No
Final verdict:			

Interoperability Test Description			
Identifier:	TD_DSC_VHF_GC_0004		
Summary:	'Sending Group call on a Distress channel'		
Configuration:	CF_2		
References:	ETSI EN 300 338-5 [1], clause 6.6.1		
Pre-test conditions:	QE1 and EUT in standby on CH:16 QE1 programmed with a group MMSI		
Step	Test Sequence	Verdict	
		Pass	Fail
1	On EUT select 'Call' then select 'Group - Routine'		
2	Enter/select MMSI of QE1		
3	Verify that menu proposes an Inter-ship Channel	Yes	No
4	Enter a distress channel as working channel		
5	Cause EUT to send the group call to QE1		
6	Verify that EUT does not send the call and indicates a channel selection error	Yes	No
Final verdict:			

6.3 All Ships Calls

Interoperability Test Description			
Identifier:	TD_DSC_VHF_ASC_0001		
Summary:	'Sending All Ships call - Safety'		
Configuration:	CF_2		
References:	ETSI EN 300 338-5 [1], clauses 5.2.3 and 6.6.1		
Pre-test conditions:			
Step	Test Sequence	Verdict	
		Pass	Fail
1	On EUT select 'Call' then select 'All Ships - Safety'		
2	Verify that the proposed channel is CH:16	Yes	No
3	Change the proposed channel to CH:06		
4	Cause EUT to send the call		
5	Verify that QE1 receives the call and sounds the Safety alarm	Yes	No
6	Verify that QE1 displays the MMSI of the EUT	Yes	No
7	Verify the voice communication on CH:06	Yes	No
Final verdict:			

Interoperability Test Description			
Identifier:	TD_DSC_VHF_ASC_0002		
Summary:	'Sending All Ships call - Urgency'		
Configuration:	CF_2		
References:	ETSI EN 300 338-5 [1], clauses 5.2.3 and 6.6.1		
Pre-test conditions:			
Step	Test Sequence	Verdict	
		Pass	Fail
1	On EUT select 'Call' then select 'All Ships - Urgency'		
2	Verify that the proposed channel is CH:16	Yes	No
3	Change the proposed channel to CH:06		
4	Cause EUT to send the call		
5	Verify that QE1 receives the call and sounds the Urgency alarm	Yes	No
6	Verify that QE1 displays the MMSI of the EUT	Yes	No
7	Verify the voice communication on CH:06	Yes	No
Final verdict:			

Interoperability Test Description			
Identifier:	TD_DSC_VHF_ASC_0003		
Summary:	'Receiving All Ships call - Urgency'		
Configuration:	CF_2		
References:	ETSI EN 300 338-5 [1], clauses 5.2.3 and 6.7.1		
Pre-test conditions:			
Step	Test Sequence	Verdict	
		Pass	Fail
1	On QE1 select 'Call' then select 'All Ships - Urgency'		
2	Change the proposed channel to CH:06		
3	Cause QE1 to send the call		
4	Verify that EUT receives the call and sounds the Urgency alarm	Yes	No
5	Verify that EUT displays the MMSI of QE1	Yes	No
6	Verify the voice communication on CH:06	Yes	No
Final verdict:			

Interoperability Test Description			
Identifier:	TD_DSC_VHF_ASC_0004		
Summary:	'Receiving All Ships call - Safety'		
Configuration:	CF_2		
References:	ETSI EN 300 338-5 [1], clauses 5.2.3 and 6.7.1		
Pre-test conditions:			
Step	Test Sequence	Verdict	
		Pass	Fail
1	On QE1 select 'Call' then select 'All Ships - Safety'		
2	Change the proposed channel to CH:06		
3	Cause QE1 to send the call		
4	Verify that EUT receives the call and sounds the Safety alarm	Yes	No
5	Verify that EUT displays the MMSI of QE1	Yes	No
6	Verify the voice communication on CH:06	Yes	No
Final verdict:			

6.4 Sending Distress Alerts

6.4.0 General Operation

Interoperability Test Description			
Identifier:	TD_DSC_VHF_SDA_0001		
Summary:	'Sending distress alert - stop before countdown'		
Configuration:	CF_1		
References:	ETSI EN 300 338-5 [1], clause 6.4.4		
Pre-test conditions:			
Step	Test Sequence	Verdict	
		Pass	Fail
1	On EUT perform action 1 for sending distress alerts		
2	On EUT perform action 2 for sending distress alerts		
3	Verify that action 1 and action 2 are different	Yes	No
4	Verify that EUT displays a countdown to sending	Yes	No
5	Verify that EUT sounds a count alarm	Yes	No
6	Verify the EUT gives a visible alarm	Yes	No
7	Stop action 2 (step 2) before countdown expires		
8	Verify that QE1 does not receive a distress alert	Yes	No
9	Verify that EUT returns to standby	Yes	No
Final verdict:			

Interoperability Test Description			
Identifier:	TD_DSC_VHF_SDA_0002		
Summary:	'Sending distress alert - undesignated alert content'		
Configuration:	CF_1		
References:	ETSI EN 300 338-5 [1], clause 6.4.4		
Pre-test conditions:			
Step	Test Sequence	Verdict	
		Pass	Fail
1	On EUT perform action 1 for sending distress alerts		
2	On EUT perform action 2 for sending distress alerts		
3	Verify that action 1 and action 2 are different	Yes	No
4	Verify that EUT displays a countdown to sending	Yes	No
5	Verify that EUT sounds a count alarm	Yes	No
6	Verify the EUT gives a visible alarm	Yes	No
7	Continue action 2 (step 2) until countdown expires		
8	Verify that QE1 receives the distress alert	Yes	No
9	Verify that QE1 displays the MMSI of EUT	Yes	No
10	Verify that QE1 displays nature of distress = undesignated	Yes	No
11	Verify that QE1 displays the position and time from EUT	Yes	No
12	Verify the voice communication between EUT and QE1 on CH:16	Yes	No
Final verdict:			

Interoperability Test Description			
Identifier:	TD_DSC_VHF_SDA_0003		
Summary:	'Validation of displaying the correct alert attempt sub-stage information'		
Configuration:	CF_2		
References:	ETSI EN 300 338-5 [1], clauses 6.4.4, 6.4.10 and 6.5.3		
Pre-test conditions:			
Step	Test Sequence	Verdict	
		Pass	Fail
1	On EUT push Distress Button		
2	Release the distress button after the countdown is complete		
3	Verify that EUT briefly displays 'transmitting' sub-stage when the countdown has completed	Yes	No
4	Verify that EUT displays 'waiting for acknowledgement' sub-stage and displays the elapsed time since this sub-stage started	Yes	No
5	On QE1 acknowledge the EUT's alarm		
6	Verify that EUT displays 'acknowledged' sub-stage and displays the elapsed time since this sub-stage started	Yes	No
Final verdict:			

Interoperability Test Description			
Identifier:	TD_DSC_VHF_SDA_0004		
Summary:	'Validation that the required items of the automated procedure are being properly displayed'		
Configuration:	CF_1		
References:	ETSI EN 300 338-5 [1], clauses 6.4.2 and 6.4.3		
Pre-test conditions:			
Step	Test Sequence	Verdict	
		Pass	Fail
1	On EUT push the Distress Button		
2	Release the distress button after the countdown is complete		
3	Verify that the EUT indicates that it is in transmitting state during distress alert transmission	Yes	No
4	Verify that the remaining time to the next automated sending of the distress alert attempt is displayed on the EUT screen	Yes	No
5	Verify that the EUT sets the time to the next automated alert sending to between 3,5 minutes and 4,5 minutes, and check that this interval is different each time	Yes	No
6	Verify that the EUT still indicates that it is waiting for an acknowledgement	Yes	No
7	Verify that the option to pause the countdown to the next distress alert attempt is available on the EUT	Yes	No
8	Verify that the option to cancel the distress alert attempt is available on the EUT	Yes	No
9	Verify that the option to resend the distress alert attempt is available on the EUT	Yes	No
Final verdict:			

Interoperability Test Description			
Identifier:	TD_DSC_VHF_SDA_0005		
Summary:	'Validation that a paused automated procedure can be resumed'		
Configuration:	CF_1		
References:	ETSI EN 300 338-5 [1], clauses 6.4.2 and 6.4.3		
Pre-test conditions:			
Step	Test Sequence	Verdict	
		Pass	Fail
1	On EUT push the Distress Button		
2	Release the distress button after the countdown is complete		
3	Wait until the EUT is in a countdown to the next distress alert attempt and pause the countdown		
4	Verify that the option to resume the countdown to the next distress alert attempt is available on the EUT	Yes	No
Final verdict:			

Interoperability Test Description			
Identifier:	TD_DSC_VHF_SDA_0006		
Summary:	'Validation of the alert cancel procedure - warning'		
Configuration:	CF_1		
References:	ETSI EN 300 338-5 [1], clauses 6.4.2 and 6.4.3		
Pre-test conditions:			
Step	Test Sequence	Verdict	
		Pass	Fail
1	On EUT push the Distress Button		
2	Release the distress button after the countdown is complete		
3	Wait until the EUT is in a countdown to the next distress alert transmission attempt and cancel the countdown		
4	Verify that the EUT displays a warning about the initiated cancel procedure, and offers the possibility of exiting the cancel procedure	Yes	No
Final verdict:			

Interoperability Test Description			
Identifier:	TD_DSC_VHF_SDA_0007		
Summary:	'Validation of the alert cancel procedure'		
Configuration:	CF_1		
References:	ETSI EN 300 338-5 [1], clauses 6.4.2 and 6.4.3		
Pre-test conditions:			
Step	Test Sequence	Verdict	
		Pass	Fail
1	On EUT push the Distress Button		
2	Release the distress button after the countdown is complete		
3	Wait until the EUT is in a countdown to the next distress alert transmission attempt and cancel the distress alert		
4	When the EUT displays a warning about the initiated cancel procedure confirm the cancellation		
5	Verify that QE1 receives the distress cancel	Yes	No
6	Verify that EUT requests voice cancellation and displays suitable text to be read	Yes	No
7	Verify that it is not possible to exit the procedure until the voice cancellation been manually processed	Yes	No
8	Verify that when all the voice call has been processed that the procedure goes to 'acknowledged' state and can be exited	Yes	No
Final verdict:			

Interoperability Test Description			
Identifier:	TD_DSC_VHF_SDA_0008		
Summary:	'Validation that the required items of the alert acknowledgement are being properly displayed'		
Configuration:	CF_2		
References:	ETSI EN 300 338-5 [1], clauses 6.4.2, 6.4.3 and 6.4.12		
Pre-test conditions:	The EUT having sent a distress alert		
Step	Test Sequence	Verdict	
		Pass	Fail
1	On QE1 acknowledge the EUT's distress alert		
2	Verify that the EUT displays the means to silence the alarm	Yes	No
3	Verify that the EUT indicates the MMSI of QE1	Yes	No
4	Verify that the operator can speak to QE1 from the EUT	Yes	No
5	Verify that the operator can speak to the EUT from QE1	Yes	No
6	Verify that the EUT no longer offers the option to resend the distress alert attempt	Yes	No
7	Verify that the EUT no longer offers the option to cancel the distress alert attempt	Yes	No
8	Verify that the EUT offers the option to terminate the sending distress automated procedure	Yes	No
9	Verify that the EUT offers the option to put the sending distress automated procedure on hold	Yes	No
Final verdict:			

Interoperability Test Description			
Identifier:	TD_DSC_VHF_SDA_0009		
Summary:	'Validation that the automated alert resending procedure stops after acknowledgement'		
Configuration:	CF_2		
References:	ETSI EN 300 338-5 [1], clauses 6.4.2 and 6.4.3		
Pre-test conditions:	The EUT having transmitted a first distress alert attempt		
Step	Test Sequence	Verdict	
		Pass	Fail
1	On QE1 acknowledge the EUT's distress alert		
2	Verify that QE1 does not receive from the EUT any further distress alert transmission attempts	Yes	No
Final verdict:			

Interoperability Test Description			
Identifier:	TD_DSC_VHF_SDA_0010		
Summary:	'Validation that repeated distress alert acknowledgements only sound the discrete alarm'		
Configuration:	CF_6		
References:	ETSI EN 300 338-5 [1], clauses 6.4.7 and 6.4.8		
Pre-test conditions:	The EUT having transmitted a first distress alert attempt		
Step	Test Sequence	Verdict	
		Pass	Fail
1	On QE1 acknowledge the EUT's distress alert		
2	Verify that the EUT sounds the manually terminated acknowledgement alarm	Yes	No
3	On QE2 acknowledge the EUT's distress alert		
4	Verify that the EUT sounds only the self-terminating alarm	Yes	No
Final verdict:			

6.4.1 Distress alert sending priority

Interoperability Test Description			
Identifier:	TD_DSC_VHF_SDA_0011		
Summary:	'Distress alert during DSC call preparation'		
Configuration:	CF_5		
References:	ETSI EN 300 338-5 [1], clauses 6.4.4 and 6.9.2.1		
Pre-test conditions:			
Step	Test Sequence	Verdict	
		Pass	Fail
1	On the EUT select the option to send an individual DSC message of priority routine and enter/select the MMSI of QE2		
2	Before the DSC message is actually sent, start the distress alert attempt by using the dedicated distress button		
3	Release the distress button after the countdown is complete		
4	Verify that QE1 receives the EUT's distress alert	Yes	No
5	Verify that QE1 receives distress information with default values and the indicated alert sender is the EUT	Yes	No
Final verdict:			

Interoperability Test Description			
Identifier:	TD_DSC_VHF_SDA_0012		
Summary:	'Distress alert after DSC call initiation'		
Configuration:	CF_5		
References:	ETSI EN 300 338-5 [1], clauses 6.4.4 and 6.9.2.1		
Pre-test conditions:			
Step	Test Sequence	Verdict	
		Pass	Fail
1	On the EUT select the option to send an individual DSC message of priority routine and enter/select the MMSI of QE2		
2	After the non-distress DSC automated sending procedure has started on EUT, start the distress alert attempt by using the dedicated distress button		
3	Release the distress button after the countdown is complete		
4	Verify that QE1 receives the EUT's distress alert	Yes	No
5	Verify that QE1 receives distress information with default values and the indicated alert sender is the EUT	Yes	No
Final verdict:			

Interoperability Test Description			
Identifier:	TD_DSC_VHF_SDA_0013		
Summary:	'Validation that repeated pressing of distress button is appropriately handled'		
Configuration:	CF_1		
References:	ETSI EN 300 338-5 [1], clause 6.4.4		
Pre-test conditions:			
Step	Test Sequence	Verdict	
		Pass	Fail
1	On EUT push the Distress Button		
2	Release the distress button of the EUT after the countdown is complete, and then push again the Distress Button		
3	Verify that on the EUT this action of repeated pushing of the distress button is ignored or activates the resend procedure	Yes	No
4	Verify that the ongoing sending distress alert automated procedure on the EUT is uninterrupted	Yes	No
Final verdict:			

Interoperability Test Description			
Identifier:	TD_DSC_VHF_SDA_0014		
Summary:	'Distress alert after reception of a preceding distress alert'		
Configuration:	CF_5		
References:	ETSI EN 300 338-5 [1], clauses 6.4.4 and 6.9.2.1		
Pre-test conditions:			
Step	Test Sequence	Verdict	
		Pass	Fail
1	On QE2 push the Distress Button		
2	Release the distress button after the countdown is complete		
3	After the DSC alert has been received on EUT, start the distress alert attempt by using the dedicated distress button		
4	Release the distress button after the countdown is complete		
5	Verify that QE1 receives the EUT's distress alert	Yes	No
6	Verify that QE1 receives distress information with default values and the indicated alert sender is the EUT	Yes	No
Final verdict:			

Interoperability Test Description			
Identifier:	TD_DSC_VHF_SDA_0015		
Summary:	'Distress alert after DSC call reception'		
Configuration:	CF_5		
References:	ETSI EN 300 338-5 [1], clauses 6.4.4 and 6.9.2.1		
Pre-test conditions:			
Step	Test Sequence	Verdict	
		Pass	Fail
1	On the QE2 select the option to send an individual DSC message of priority routine and enter/select the MMSI of the EUT		
2	After the non-distress DSC automated reception procedure has started on EUT, start the distress alert attempt by using the dedicated distress button		
3	Release the distress button after the countdown is complete		
4	Verify that QE1 receives the EUT's distress alert	Yes	No
5	Verify that QE1 receives distress information with default values and the indicated alert sender is the EUT	Yes	No
Final verdict:			

6.4.2 Ongoing distress alert priority

Interoperability Test Description			
Identifier:	TD_DSC_VHF_SDA_0016		
Summary:	'Validation of ongoing distress alert priority for distress alert relay reception'		
Configuration:	CF_4		
References:	ETSI EN 300 338-5 [1], clause 6.4.7		
Pre-test conditions:	EUT having sent a distress alert and being in 'waiting for acknowledgement' sub-stage		
Step	Test Sequence	Verdict	
		Pass	Fail
1	On QE2 press the distress alert button, and have QE1 relay the received distress alert to the EUT		
2	Verify that the EUT remains in 'waiting for acknowledgement' sub-stage	Yes	No
3	Verify that reception of the above DSC event does not trigger an alarm in the EUT	Yes	No
4	Verify that reception of the above DSC event does raise the 'Unread call in the memory' flag in the EUT	Yes	No
5	Verify that the EUT stores the above DSC event record in its log	Yes	No
6	On QE1 acknowledge the EUT's distress alert		
7	On QE2 resend the distress alert, and have QE1 relay the received distress alert to the EUT		
8	Verify that the EUT remains in 'alert acknowledged' sub-stage	Yes	No
9	Verify that reception of the above DSC event does trigger an alarm in the EUT	Yes	No
10	Verify that reception of the above DSC event initiates a new procedure on hold	Yes	No
Final verdict:			

Interoperability Test Description			
Identifier:	TD_DSC_VHF_SDA_0017		
Summary:	'Validation of ongoing distress alert priority for All ships RT call Safety'		
Configuration:	CF_2		
References:	ETSI EN 300 338-5 [1], clause 6.4.7		
Pre-test conditions:	EUT having sent a distress alert and being in 'waiting for acknowledgement' sub-stage		
Step	Test Sequence	Verdict	
		Pass	Fail
1	On QE1 initiate an 'All ships RT call Safety' procedure		
2	Verify that the EUT remains in 'waiting for acknowledgement' sub-stage	Yes	No
3	Verify that reception of the above DSC event does not trigger an alarm in the EUT	Yes	No
4	Verify that reception of the above DSC event does raise the 'Unread call in the memory' flag in the EUT	Yes	No
5	Verify that the EUT stores the above DSC event record in its log	Yes	No
6	On QE1 acknowledge the EUT's distress alert		
7	On QE1 initiate a new 'All ships RT call Safety' procedure		
8	Verify that the EUT remains in 'alert acknowledged' sub-stage	Yes	No
9	Verify that reception of the above DSC event does trigger an alarm in the EUT	Yes	No
10	Verify that reception of the above DSC event initiates a new procedure on hold	Yes	No
Final verdict:			

Interoperability Test Description			
Identifier:	TD_DSC_VHF_SDA_0018		
Summary:	'Validation of ongoing distress alert priority for All ships RT call Urgency'		
Configuration:	CF_2		
References:	ETSI EN 300 338-5 [1], clause 6.4.7		
Pre-test conditions:	EUT having sent a distress alert and being in 'waiting for acknowledgement' sub-stage		
Step	Test Sequence	Verdict	
		Pass	Fail
1	On QE1 initiate an 'All ships RT call Urgency' procedure		
2	Verify that the EUT remains in 'waiting for acknowledgement' sub-stage	Yes	No
3	Verify that reception of the above DSC event does not trigger an alarm in the EUT	Yes	No
4	Verify that reception of the above DSC event does raise the 'Unread call in the memory' flag in the EUT	Yes	No
5	Verify that the EUT stores the above DSC event record in its log	Yes	No
6	On QE1 acknowledge the EUT's distress alert		
7	On QE1 initiate a new 'All ships RT call Urgency' procedure		
8	Verify that the EUT remains in 'alert acknowledged' sub-stage	Yes	No
9	Verify that reception of the above DSC event does trigger an alarm in the EUT	Yes	No
10	Verify that reception of the above DSC event initiates a new procedure on hold	Yes	No
Final verdict:			

Interoperability Test Description			
Identifier:	TD_DSC_VHF_SDA_0019		
Summary:	'Validation of ongoing distress alert priority for Individual RT call Safety'		
Configuration:	CF_2		
References:	ETSI EN 300 338-5 [1], clause 6.4.7		
Pre-test conditions:	EUT having sent a distress alert and being in 'waiting for acknowledgement' sub-stage		
Step	Test Sequence	Verdict	
		Pass	Fail
1	On QE1 initiate an 'Individual RT call Safety' procedure addressed to the EUT		
2	Verify that the EUT remains in 'waiting for acknowledgement' sub-stage	Yes	No
3	Verify that reception of the above DSC event does not trigger an alarm in the EUT	Yes	No
4	Verify that reception of the above DSC event does raise the 'Unread call in the memory' flag in the EUT	Yes	No
5	Verify that the EUT stores the above DSC event record in its log	Yes	No
6	On QE1 acknowledge the EUT's distress alert		
7	On QE1 initiate a new 'Individual RT call Safety' procedure addressed to the EUT		
8	Verify that the EUT remains in 'alert acknowledged' sub-stage	Yes	No
9	Verify that reception of the above DSC event does trigger an alarm in the EUT	Yes	No
10	Verify that reception of the above DSC event initiates a new procedure on hold	Yes	No
Final verdict:			

Interoperability Test Description			
Identifier:	TD_DSC_VHF_SDA_0020		
Summary:	'Validation of ongoing distress alert priority for Individual RT call Urgency'		
Configuration:	CF_2		
References:	ETSI EN 300 338-5 [1], clause 6.4.7		
Pre-test conditions:	EUT having sent a distress alert and being in 'waiting for acknowledgement' sub-stage		
Step	Test Sequence	Verdict	
		Pass	Fail
1	On QE1 initiate an 'Individual RT call Urgency' procedure addressed to the EUT		
2	Verify that the EUT remains in 'waiting for acknowledgement' sub-stage	Yes	No
3	Verify that reception of the above DSC event does not trigger an alarm in the EUT	Yes	No
4	Verify that reception of the above DSC event does raise the 'Unread call in the memory' flag in the EUT	Yes	No
5	Verify that the EUT stores the above DSC event record in its log	Yes	No
6	On QE1 acknowledge the EUT's distress alert		
7	On QE1 initiate a new 'Individual RT call Urgency' procedure addressed to the EUT		
8	Verify that the EUT remains in 'alert acknowledged' sub-stage	Yes	No
9	Verify that reception of the above DSC event does trigger an alarm in the EUT	Yes	No
10	Verify that reception of the above DSC event initiates a new procedure on hold	Yes	No
Final verdict:			

Interoperability Test Description			
Identifier:	TD_DSC_VHF_SDA_0021		
Summary:	'Validation of ongoing distress alert priority for Routine Individual RT call'		
Configuration:	CF_2		
References:	ETSI EN 300 338-5 [1], clause 6.4.7		
Pre-test conditions:	EUT having sent a distress alert and being in 'waiting for acknowledgement' sub-stage		
Step	Test Sequence	Verdict	
		Pass	Fail
1	On QE1 initiate a 'Routine RT call' procedure addressed to the EUT		
2	Verify that the EUT remains in 'waiting for acknowledgement' sub-stage	Yes	No
3	Verify that reception of the above DSC event does not trigger an alarm in the EUT	Yes	No
4	Verify that reception of the above DSC event does raise the 'Unread call in the memory' flag in the EUT	Yes	No
5	Verify that the EUT stores the above DSC event record in its log	Yes	No
6	On QE1 acknowledge the EUT's distress alert		
7	On QE1 initiate a new 'Routine RT call' procedure addressed to the EUT		
8	Verify that the EUT remains in 'alert acknowledged' sub-stage	Yes	No
9	Verify that reception of the above DSC event does trigger an alarm in the EUT	Yes	No
10	Verify that reception of the above DSC event initiates a new procedure on hold	Yes	No
Final verdict:			

Interoperability Test Description			
Identifier:	TD_DSC_VHF_SDA_0022		
Summary:	'Validation of ongoing distress alert priority for a received other distress alert'		
Configuration:	CF_5		
References:	ETSI EN 300 338-5 [1], clause 6.4.7		
Pre-test conditions:	EUT having sent a distress alert and being in 'waiting for acknowledgement' sub-stage		
Step	Test Sequence	Verdict	
		Pass	Fail
1	On QE2 press the distress alert button		
2	Verify that the EUT remains in 'waiting for acknowledgement' sub-stage	Yes	No
3	Verify that reception of the above DSC event does not trigger an alarm in the EUT	Yes	No
4	Verify that reception of the above DSC event does raise the 'Unread call in the memory' flag in the EUT	Yes	No
5	Verify that the EUT stores the above DSC event record in its log	Yes	No
6	On QE1 acknowledge the EUT's distress alert		
7	On QE2 press the distress alert button again		
8	Verify that the EUT remains in 'alert acknowledged' sub-stage	Yes	No
9	Verify that reception of the above DSC event does trigger an alarm in the EUT	Yes	No
10	Verify that reception of the above DSC event initiates a new procedure on hold	Yes	No
Final verdict:			

6.4.3 Manual termination after distress alert acknowledgement

Interoperability Test Description			
Identifier:	TD_DSC_VHF_SDA_0023		
Summary:	'Validation of distress alert termination'		
Configuration:	CF_2		
References:	ETSI EN 300 338-5 [1], clause 6.4.13		
Pre-test conditions:	EUT having sent a distress alert and being in 'waiting for acknowledgement' sub-stage		
Step	Test Sequence	Verdict	
		Pass	Fail
1	Verify that the EUT does not offer the option to terminate the current distress alert procedure	Yes	No
2	On QE1 acknowledge the EUT's distress alert		
3	Verify that the EUT offers the option to terminate the current distress alert procedure	Yes	No
Final verdict:			

Interoperability Test Description			
Identifier:	TD_DSC_VHF_SDA_0024		
Summary:	'Validation of not automatically displaying logged DSC alert messages after current alert termination'		
Configuration:	CF_5		
References:	ETSI EN 300 338-5 [1], clause 6.4.13		
Pre-test conditions:	EUT having sent a distress alert and being in 'waiting for acknowledgement' sub-stage		
Step	Test Sequence	Verdict	
		Pass	Fail
1	On QE2 push the Distress alert button		
2	On QE1 acknowledge the EUT's distress alert		
3	On EUT terminate the current distress alert		
4	Verify that the EUT does not automatically start displaying the new DSC alert message from memory	Yes	No
Final verdict:			

Interoperability Test Description			
Identifier:	TD_DSC_VHF_SDA_0025		
Summary:	'Validation of selecting and sending Fire/Explosion nature of distress'		
Configuration:	CF_1		
References:	ETSI EN 300 338-5 [1], clauses 6.4.4 and 6.3 d)		
Pre-test conditions:			
Step	Test Sequence	Verdict	
		Pass	Fail
1	Enter distress alert set up menu on EUT		
2	Verify that the dedicated button for sending distress alerts is not used for accessing this menu	Yes	No
3	Select 'Fire/Explosion' nature of distress, and cause EUT to send the alert		
4	Verify that QE1 receives the nature of distress alert 'Fire/Explosion'	Yes	No
Final verdict:			

Interoperability Test Description			
Identifier:	TD_DSC_VHF_SDA_0026		
Summary:	'Validation of selecting and sending Flooding nature of distress'		
Configuration:	CF_1		
References:	ETSI EN 300 338-5 [1], clauses 6.4.4 and 6.3 d)		
Pre-test conditions:			
Step	Test Sequence	Verdict	
		Pass	Fail
1	Enter distress alert set up menu on EUT		
2	Verify that the dedicated button for sending distress alerts is not used for accessing this menu	Yes	No
3	Select 'Flooding' nature of distress, and cause EUT to send the alert		
4	Verify that QE1 receives the nature of distress alert 'Flooding'	Yes	No
Final verdict:			

Interoperability Test Description			
Identifier:	TD_DSC_VHF_SDA_0027		
Summary:	'Validation of selecting and sending Collision nature of distress'		
Configuration:	CF_1		
References:	ETSI EN 300 338-5 [1], clauses 6.4.4 and 6.3 d)		
Pre-test conditions:			
Step	Test Sequence	Verdict	
		Pass	Fail
1	Enter distress alert set up menu on EUT		
2	Verify that the dedicated button for sending distress alerts is not used for accessing this menu	Yes	No
3	Select 'Collision' nature of distress, and cause EUT to send the alert		
4	Verify that QE1 receives the nature of distress alert 'Collision'	Yes	No
Final verdict:			

Interoperability Test Description			
Identifier:	TD_DSC_VHF_SDA_008		
Summary:	'Validation of selecting and sending Grounding nature of distress'		
Configuration:	CF_1		
References:	ETSI EN 300 338-5 [1], clauses 6.4.4 and 6.3 d)		
Pre-test conditions:			
Step	Test Sequence	Verdict	
		Pass	Fail
1	Enter distress alert set up menu on EUT		
2	Verify that the dedicated button for sending distress alerts is not used for accessing this menu	Yes	No
3	Select 'Grounding' nature of distress, and cause EUT to send the alert		
4	Verify that QE1 receives the nature of distress alert 'Grounding'	Yes	No
Final verdict:			

Interoperability Test Description			
Identifier:	TD_DSC_VHF_SDA_0029		
Summary:	'Validation of selecting and sending Listing/Capsizing nature of distress'		
Configuration:	CF_1		
References:	ETSI EN 300 338-5 [1], clauses 6.4.4 and 6.3 d)		
Pre-test conditions:			
Step	Test Sequence	Verdict	
		Pass	Fail
1	Enter distress alert set up menu on EUT		
2	Verify that the dedicated button for sending distress alerts is not used for accessing this menu	Yes	No
3	Select 'Listing/Capsizing' nature of distress, and cause EUT to send the alert		
4	Verify that QE1 receives the nature of distress alert 'Listing/Capsizing'	Yes	No
Final verdict:			

Interoperability Test Description			
Identifier:	TD_DSC_VHF_SDA_0030		
Summary:	'Validation of selecting and sending Sinking nature of distress'		
Configuration:	CF_1		
References:	ETSI EN 300 338-5 [1], clauses 6.4.4 and 6.3 d)		
Pre-test conditions:			
Step	Test Sequence	Verdict	
		Pass	Fail
1	Enter distress alert set up menu on EUT		
2	Verify that the dedicated button for sending distress alerts is not used for accessing this menu	Yes	No
3	Select 'Sinking' nature of distress, and cause EUT to send the alert		
4	Verify that QE1 receives the nature of distress alert 'Sinking'	Yes	No
Final verdict:			

Interoperability Test Description			
Identifier:	TD_DSC_VHF_SDA_0031		
Summary:	'Validation of selecting and sending Disabled and Adrift nature of distress'		
Configuration:	CF_1		
References:	ETSI EN 300 338-5 [1], clauses 6.4.4 and 6.3 d)		
Pre-test conditions:			
Step	Test Sequence	Verdict	
		Pass	Fail
1	Enter distress alert set up menu on EUT		
2	Verify that the dedicated button for sending distress alerts is not used for accessing this menu	Yes	No
3	Select 'Disabled and Adrift' nature of distress, and cause EUT to send the alert		
4	Verify that QE1 receives the nature of distress alert 'Disabled and Adrift'	Yes	No
Final verdict:			

Interoperability Test Description			
Identifier:	TD_DSC_VHF_SDA_0032		
Summary:	'Validation of selecting and sending Abandoning ship nature of distress'		
Configuration:	CF_1		
References:	ETSI EN 300 338-5 [1], clauses 6.4.4 and 6.3 d)		
Pre-test conditions:			
Step	Test Sequence	Verdict	
		Pass	Fail
1	Enter distress alert set up menu on EUT		
2	Verify that the dedicated button for sending distress alerts is not used for accessing this menu	Yes	No
3	Select 'Abandoning ship' nature of distress, and cause EUT to send the alert		
4	Verify that QE1 receives the nature of distress alert 'Abandoning ship'	Yes	No
Final verdict:			

Interoperability Test Description			
Identifier:	TD_DSC_VHF_SDA_0033		
Summary:	'Validation of selecting and sending Piracy/Armed attack nature of distress'		
Configuration:	CF_1		
References:	ETSI EN 300 338-5 [1], clauses 6.4.4 and 6.3 d)		
Pre-test conditions:			
Step	Test Sequence	Verdict	
		Pass	Fail
1	Enter distress alert set up menu on EUT		
2	Verify that the dedicated button for sending distress alerts is not used for accessing this menu	Yes	No
3	Select 'Piracy/Armed attack' nature of distress, and cause EUT to send the alert		
4	Verify that QE1 receives the nature of distress alert 'Piracy/Armed attack'	Yes	No
Final verdict:			

Interoperability Test Description			
Identifier:	TD_DSC_VHF_SDA_0034		
Summary:	'Validation of selecting and sending Man overboard nature of distress'		
Configuration:	CF_1		
References:	ETSI EN 300 338-5 [1], clauses 6.4.4 and 6.3 d)		
Pre-test conditions:			
Step	Test Sequence	Verdict	
		Pass	Fail
1	Enter distress alert set up menu on EUT		
2	Verify that the dedicated button for sending distress alerts is not used for accessing this menu	Yes	No
3	Select 'Man overboard' nature of distress, and cause EUT to send the alert		
4	Verify that QE1 receives the nature of distress alert 'Man overboard'	Yes	No
Final verdict:			

Interoperability Test Description			
Identifier:	TD_DSC_VHF_SDA_0035		
Summary:	'Validation of unavailability of EPIRB nature of distress'		
Configuration:	CF_1		
References:	ETSI EN 300 338-5 [1], clauses 6.4.4 and 6.3 d)		
Pre-test conditions:			
Step	Test Sequence	Verdict	
		Pass	Fail
1	Enter distress alert set up menu on EUT		
2	Verify that 'EPIRB' nature of distress cannot be selected on the EUT	Yes	No
Final verdict:			

Interoperability Test Description			
Identifier:	TD_DSC_VHF_SDA_0036		
Summary:	Updating of position and time during distress alert resending		
Configuration:	CF_1		
References:	ETSI EN 300 338-5 [1], clause 6.4.6		
Pre-test conditions:			
Step	Test Sequence	Verdict	
		Pass	Fail
1	On the EUT push the Distress Button		
2	Release the distress button after the countdown is complete		
3	Wait that the distress alert attempt is being resent several times, and change the position of the EUT between retransmissions		
4	Verify that QE1 receives subsequent distress alert messages with the updated UTC time information	Yes	No
5	Verify that QE1 receives subsequent distress alert messages with the updated geographic position information	Yes	No
Final verdict:			

6.5 Receiving Distress Alerts

Interoperability Test Description			
Identifier:	TD_DSC_VHF_RDA_0001		
Summary:	Basic test of receiving distress automated procedure		
Configuration:	CF_1		
References:	ETSI EN 300 338-5 [1], clause 6.5		
Pre-test conditions:			
Step	Test Sequence	Verdict	
		Pass	Fail
1	On QE1 push the Distress Button		
2	Release the distress button after the countdown is complete		
3	Verify that EUT correctly displays the UTC time information of the above distress alert message	Yes	No
4	Verify that the EUT correctly displays the geographic position information of QE1 at the time of above distress alert message, including fractional minutes or seconds of latitude and longitude	Yes	No
5	Verify that the EUT correctly displays the sender MMSI, intended recipients, and indicates that the DSC message type is 'distress alert'	Yes	No
6	Verify that the EUT selects the default channel 16 (VHF) frequency of subsequent communication	Yes	No
7	Verify that the EUT displays at top level the elapsed time since receiving the first alert	Yes	No
8	Verify that the option to send a distress relay is NOT available on the EUT	Yes	No
9	Verify that the option to send a distress alert acknowledgement is NOT available on the EUT	Yes	No
10	Verify that the option to send a distress relay acknowledgement is NOT available on the EUT	Yes	No
11	Verify that the option to terminate the procedure is available on the EUT	Yes	No
12	Verify that the EUT correctly displays at top level the current stage of the distress alert procedure - i.e. waiting for acknowledgement	Yes	No
13	Verify that the EUT offers the option to display information about the history of received DSC messages pertinent to the current distress alert procedure	Yes	No
14	Verify that the operator can speak to QE1 from the EUT	Yes	No
15	Verify that the operator can speak to the EUT from QE1	Yes	No
16	Verify that the EUT offers the option to terminate the current distress alert procedure	Yes	No
17	On the EUT select the option to terminate the current distress alert procedure		
18	Verify that the EUT gives a warning that the current distress alert procedure is being terminated	Yes	No
Final verdict:			

Interoperability Test Description			
Identifier:	TD_DSC_VHF_RDA_0002		
Summary:	Test of all ships relay triggered receiving distress automated procedure		
Configuration:	CF_4		
References:	ETSI EN 300 338-5 [1], clause 6.5		
Pre-test conditions:	EUT has the option to receive this call type QE2 having sent a distress alert message and QE1 having received the call		
Step	Test Sequence	Verdict	
		Pass	Fail
1	Make QE1 relay the received distress alert addressed to all ships		
2	Verify that EUT correctly displays the UTC time information of the relayed distress alert message	Yes	No
3	Verify that the EUT correctly displays the geographic position information of QE2 at the time of above distress alert message, including fractional minutes or seconds of latitude and longitude	Yes	No
4	Verify that the EUT correctly displays the QE2's MMSI, intended recipients, and indicates that the DSC message type is 'distress alert'	Yes	No
5	Verify that the EUT selects the default channel 16 (VHF) frequency of subsequent communication	Yes	No
6	Verify that the EUT displays at top level the elapsed time since receiving the first alert	Yes	No
7	Verify that the option to send a distress alert acknowledgement is NOT available on the EUT	Yes	No
8	Verify that the option to send a distress relay acknowledgement is NOT available on the EUT	Yes	No
9	Verify that the option to terminate the procedure is available on the EUT	Yes	No
10	Verify that the EUT correctly displays at top level the current stage of the distress alert procedure - i.e. waiting for acknowledgement	Yes	No
11	Verify that the EUT offers the option to display information about the history of received DSC messages pertinent to the current distress alert procedure	Yes	No
12	Verify that the EUT offers the option to terminate the current distress alert procedure	Yes	No
13	On the EUT select the option to terminate the current distress alert procedure		
14	Verify that the EUT gives a warning that the current distress alert procedure is being terminated	Yes	No
Final verdict:			

Interoperability Test Description			
Identifier:	TD_DSC_VHF_RDA_0003		
Summary:	Test of individually addressed relay triggered receiving distress automated procedure		
Configuration:	CF_4		
References:	ETSI EN 300 338-5 [1], clause 6.5		
Pre-test conditions:	EUT has the option to receive this call type QE2 having sent a distress alert message		
Step	Test Sequence	Verdict	
		Pass	Fail
1	Make QE1 relay the received distress alert addressed to the EUT's MMSI		
2	Verify that EUT correctly displays the UTC time information of the relayed distress alert message	Yes	No
3	Verify that the EUT correctly displays the geographic position information of QE2 at the time of above distress alert message, including fractional minutes or seconds of latitude and longitude	Yes	No
4	Verify that the EUT correctly displays the QE2's MMSI, intended recipients, and indicates that the DSC message type is 'distress alert'	Yes	No
5	Verify that the EUT selects the default channel 16 (VHF) frequency of subsequent communication	Yes	No
6	Verify that the EUT displays at top level the elapsed time since receiving the first alert	Yes	No
7	Verify that the option to send a distress relay is NOT available on the EUT	Yes	No
8	Verify that the option to send a distress alert acknowledgement is NOT available on the EUT	Yes	No
9	Verify that the option to send a distress relay acknowledgement is available on the EUT	Yes	No
10	Verify that the option to terminate the procedure is available on the EUT	Yes	No
11	Verify that the EUT correctly displays at top level the current stage of the distress alert procedure - i.e. waiting for acknowledgement	Yes	No
12	Verify that the EUT offers the option to display information about the history of received DSC messages pertinent to the current distress alert procedure	Yes	No
13	Verify that the EUT offers the option to terminate the current distress alert procedure	Yes	No
14	On the EUT select the option to terminate the current distress alert procedure		
15	Verify that the EUT gives a warning that the current distress alert procedure is being terminated	Yes	No
Final verdict:			

Interoperability Test Description			
Identifier:	TD_DSC_VHF_RDA_0004		
Summary:	Testing the reception of self-acknowledged alert		
Configuration:	CF_2		
References:	ETSI EN 300 338-5 [1], clause 6.5.2		
Pre-test conditions:			
Step	Test Sequence	Verdict	
		Pass	Fail
1	Send a distress alert message from QE1, and then self-acknowledge this alarm on QE1		
2	Verify that EUT is displaying the elapsed time since having received the acknowledgement, and at top level the procedure stage is displayed as 'Cancelled'	Yes	No
Final verdict:			

Interoperability Test Description			
Identifier:	TD_DSC_VHF_RDA_0005		
Summary:	Test of the display of updated distress call information		
Configuration:	CF_1		
References:	ETSI EN 300 338-5 [1], clauses 6.5.5 and 6.5.3 c)		
Pre-test conditions:	QE1 having sent a distress alert message		
Step	Test Sequence	Verdict	
		Pass	Fail
1	Change the position of QE1 and resend the distress alert message		
2	Verify that EUT sounds a self-terminating alarm upon the reception of resent distress alert message	Yes	No
3	Verify that EUT displays the changed position in the distress information	Yes	No
4	Verify that the elapsed time since the distress receiving procedure started is not changed on the EUT	Yes	No
5	Verify that EUT displays the type of the latest received DSC message	Yes	No
Final verdict:			

Interoperability Test Description			
Identifier:	TD_DSC_VHF_RDA_0006		
Summary:	Timeout testing of distress automated procedure		
Configuration:	CF_1		
References:	ETSI EN 300 338-5 [1], clauses 6.5.3 and 6.5.9		
Pre-test conditions:			
Step	Test Sequence	Verdict	
		Pass	Fail
1	Set the no activity timeout of received distress DSC automated procedures to some value in the range [10 seconds to 10 minutes]		
2	Cause the TE to send a Distress alert		
3	Wait until the no activity timer defined in step 1 almost expires		
4	Verify that at least 10 seconds prior to automated termination a visual and aural warning is given by the EUT, indicating the nearing no activity timeout	Yes	No
5	Verify that the EUT provides the means to silence the above alarm	Yes	No
6	Verify that the EUT provides the means to stop the upcoming 'no activity termination' of the automated procedure	Yes	No
Final verdict:			

6.6 Receiving Distress Alert from MOB devices

6.6.1 Open loop MOB distress alert

Interoperability Test Description			
Identifier:	TD_DSC_VHF_MOB_0001		
Summary:	Test of receiving a distress alert from MOB device starting in open loop, automated procedure		
Configuration:	CF_3		
References:	ETSI EN 300 338-5 [1], clause 6.5		
Pre-test conditions:	QE1 shall be able to start in open loop mode to perform this test (be marked DSC-MOB-O)		
Step	Test Sequence	Verdict	
		Pass	Fail
1	Activate QE1 (trigger a MOB event)		
2	Wait until countdown is complete		
3	Verify that EUT receives a distress alert message of type man overboard.	Yes	No
4	Verify that the EUT correctly displays QE1's MMSI and it is a MOB identity starting 972 in accordance with Recommendation ITU-R M.585-8 [2].	Yes	No
Final verdict:			

6.7 Non Distress automated procedures

6.7.1 Call prioritization

6.7.1.1 Non-DSC calls

Interoperability Test Description			
Identifier:	TD_DSC_VHF_NDAP_0001		
Summary:	'Priority higher than non-DSC call'		
Configuration:	CF_1		
References:	ETSI EN 300 338-5 [1], clause 6.9		
Pre-test conditions:	EUT is busy with a non-DSC voice call		
Step	Test Sequence	Verdict	
		Pass	Fail
1	Cause QE1 to send an Individual Routine call to EUT		
2	Verify that EUT give a discrete audible alarm	Yes	No
3	Verify that EUT displays what type of call is received	Yes	No
4	Verify that EUT displays the MMSI of QE1	Yes	No
5	Verify that EUT gives the option to accept or log the call	Yes	No
6	Cause EUT to accept the call		
7	Verify the voice communication between EUT and QE1	Yes	No
Final verdict:			

Interoperability Test Description			
Identifier:	TD_DSC_VHF_NDAP_0002		
Summary:	'Priority higher than non-DSC call'		
Configuration:	CF_1		
References:	ETSI EN 300 338-5 [1], clause 6.9		
Pre-test conditions:	EUT is busy with a non-DSC voice call		
Step	Test Sequence	Verdict	
		Pass	Fail
1	Cause QE1 to send an Individual Safety call to EUT		
2	Verify that EUT give a discrete audible alarm	Yes	No
3	Verify that EUT displays what type of call is received	Yes	No
4	Verify that EUT displays the MMSI of QE1	Yes	No
5	Verify that EUT gives the option to accept or log the call	Yes	No
6	Cause EUT to accept the call		
7	Verify the voice communication between EUT and QE1	Yes	No
Final verdict:			

Interoperability Test Description			
Identifier:	TD_DSC_VHF_NDAP_0003		
Summary:	'Priority higher than non-DSC call'		
Configuration:	CF_1		
References:	ETSI EN 300 338-5 [1], clause 6.9		
Pre-test conditions:	EUT is busy with a non-DSC voice call		
Step	Test Sequence	Verdict	
		Pass	Fail
1	Cause QE1 to send an All Ships Safety call to EUT		
2	Verify that EUT give a discrete audible alarm	Yes	No
3	Verify that EUT displays what type of call is received	Yes	No
4	Verify that EUT displays the MMSI of QE1	Yes	No
5	Verify that EUT gives the option to accept or log the call	Yes	No
6	Cause EUT to accept the call		
7	Verify the voice communication between EUT and QE1	Yes	No
Final verdict:			

Interoperability Test Description			
Identifier:	TD_DSC_VHF_NDAP_0004		
Summary:	'Priority higher than non-DSC call'		
Configuration:	CF_1		
References:	ETSI EN 300 338-5 [1], clause 6.9		
Pre-test conditions:	EUT is busy with a non-DSC voice call		
Step	Test Sequence	Verdict	
		Pass	Fail
1	Cause QE1 to send an Individual Urgency call to EUT		
2	Verify that EUT give a discrete audible alarm	Yes	No
3	Verify that EUT displays what type of call is received	Yes	No
4	Verify that EUT displays the MMSI of QE1	Yes	No
5	Verify that EUT gives the option to accept or log the call	Yes	No
6	Cause EUT to accept the call		
7	Verify the voice communication between EUT and QE1	Yes	No
Final verdict:			

Interoperability Test Description			
Identifier:	TD_DSC_VHF_NDAP_0005		
Summary:	'Priority higher than non-DSC call'		
Configuration:	CF_1		
References:	ETSI EN 300 338-5 [1], clause 6.9		
Pre-test conditions:	EUT is busy with a non-DSC voice call		
Step	Test Sequence	Verdict	
		Pass	Fail
1	Cause QE1 to send an All Ships Urgency call to EUT		
2	Verify that EUT give a discrete audible alarm	Yes	No
3	Verify that EUT displays what type of call is received	Yes	No
4	Verify that EUT displays the MMSI of QE1	Yes	No
5	Verify that EUT gives the option to accept or log the call	Yes	No
6	Cause EUT to accept the call		
7	Verify the voice communication between EUT and QE1	Yes	No
Final verdict:			

Interoperability Test Description			
Identifier:	TD_DSC_VHF_NDAP_0006		
Summary:	'Priority higher than non-DSC call'		
Configuration:	CF_1		
References:	ETSI EN 300 338-5 [1], clause 6.9		
Pre-test conditions:	EUT is busy with a non-DSC voice call		
Step	Test Sequence	Verdict	
		Pass	Fail
1	Cause QE1 to send an Individual Routine call to EUT		
2	Verify that EUT give a discrete audible alarm	Yes	No
3	Verify that EUT displays what type of call is received	Yes	No
4	Verify that EUT displays the MMSI of QE1	Yes	No
5	Verify that EUT gives the option to accept or log the call	Yes	No
6	Cause EUT to accept the call		
7	Verify the voice communication between EUT and QE1	Yes	No
Final verdict:			

Interoperability Test Description			
Identifier:	TD_DSC_VHF_NDAP_0007		
Summary:	'Priority higher than non-DSC call'		
Configuration:	CF_1		
References:	ETSI EN 300 338-5 [1], clause 6.9		
Pre-test conditions:	EUT is busy with a non-DSC voice call		
Step	Test Sequence	Verdict	
		Pass	Fail
1	Cause QE1 to send a Distress category call to EUT		
2	Verify that EUT give a discrete audible alarm	Yes	No
3	Verify that EUT displays what type of call is received	Yes	No
4	Verify that EUT displays the MMSI of QE1	Yes	No
5	Verify that EUT gives the option to accept or log the call	Yes	No
6	Cause EUT to accept the call		
7	Verify the voice communication between EUT and QE1	Yes	No
Final verdict:			

6.7.1.2 Individual routine calls

Interoperability Test Description			
Identifier:	TD_DSC_VHF_NDAP_0008		
Summary:	'Priority lower than Individual call'		
Configuration:	CF_1		
References:	ETSI EN 300 338-5 [1], clause 6.9		
Pre-test conditions:	EUT is busy with an Individual routine call		
Step	Test Sequence	Verdict	
		Pass	Fail
1	Cause QE1 to send an Individual Routine call to EUT		
2	Verify that EUT give a discrete audible alarm	Yes	No
3	Verify that EUT does not display that a call was received	Yes	No
4	Verify that EUT has logged the call from QE1	Yes	No
Final verdict:			

Interoperability Test Description			
Identifier:	TD_DSC_VHF_NDAP_0009		
Summary:	'Priority higher than Individual call'		
Configuration:	CF_1		
References:	ETSI EN 300 338-5 [1], clause 6.9		
Pre-test conditions:	EUT is busy with an Individual routine call		
Step	Test Sequence	Verdict	
		Pass	Fail
1	Cause QE1 to send an Individual Safety call to EUT		
2	Verify that EUT give a discrete audible alarm	Yes	No
3	Verify that EUT displays what type of call is received	Yes	No
4	Verify that EUT displays the MMSI of QE1	Yes	No
5	Verify that EUT gives the option to accept or log the call	Yes	No
6	Cause EUT to accept the call		
7	Verify the voice communication between EUT and QE1	Yes	No
Final verdict:			

Interoperability Test Description			
Identifier:	TD_DSC_VHF_NDAP_0010		
Summary:	'Priority higher than Individual call'		
Configuration:	CF_1		
References:	ETSI EN 300 338-5 [1], clause 6.9		
Pre-test conditions:	EUT is busy with an Individual routine call		
Step	Test Sequence	Verdict	
		Pass	Fail
1	Cause QE1 to send an All Ships Safety call to EUT		
2	Verify that EUT give a discrete audible alarm	Yes	No
3	Verify that EUT displays what type of call is received	Yes	No
4	Verify that EUT displays the MMSI of QE1	Yes	No
5	Verify that EUT gives the option to accept or log the call	Yes	No
6	Cause EUT to accept the call		
7	Verify the voice communication between EUT and QE1	Yes	No
Final verdict:			

Interoperability Test Description			
Identifier:	TD_DSC_VHF_NDAP_0011		
Summary:	'Priority higher than Individual call'		
Configuration:	CF_1		
References:	ETSI EN 300 338-5 [1], clause 6.9		
Pre-test conditions:	EUT is busy with an Individual routine call		
Step	Test Sequence	Verdict	
		Pass	Fail
1	Cause QE1 to send an Individual Urgency call to EUT		
2	Verify that EUT give a discrete audible alarm	Yes	No
3	Verify that EUT displays what type of call is received	Yes	No
4	Verify that EUT displays the MMSI of QE1	Yes	No
5	Verify that EUT gives the option to accept or log the call	Yes	No
6	Cause EUT to accept the call		
7	Verify the voice communication between EUT and QE1	Yes	No
Final verdict:			

Interoperability Test Description			
Identifier:	TD_DSC_VHF_NDAP_0012		
Summary:	'Priority higher than Individual call'		
Configuration:	CF_1		
References:	ETSI EN 300 338-5 [1], clause 6.9		
Pre-test conditions:	EUT is busy with an Individual routine call		
Step	Test Sequence	Verdict	
		Pass	Fail
1	Cause QE1 to send an All Ships Urgency call to EUT		
2	Verify that EUT give a discrete audible alarm	Yes	No
3	Verify that EUT displays what type of call is received	Yes	No
4	Verify that EUT displays the MMSI of QE1	Yes	No
5	Verify that EUT gives the option to accept or log the call	Yes	No
6	Cause EUT to accept the call		
7	Verify the voice communication between EUT and QE1	Yes	No
Final verdict:			

Interoperability Test Description			
Identifier:	TD_DSC_VHF_NDAP_0013		
Summary:	'Priority higher than Individual call'		
Configuration:	CF_1		
References:	ETSI EN 300 338-5 [1], clause 6.9		
Pre-test conditions:	EUT is busy with an Individual routine call		
Step	Test Sequence	Verdict	
		Pass	Fail
1	Cause QE1 to send a Distress category call to EUT		
2	Verify that EUT give a discrete audible alarm	Yes	No
3	Verify that EUT displays what type of call is received	Yes	No
4	Verify that EUT displays the MMSI of QE1	Yes	No
5	Verify that EUT gives the option to accept or log the call	Yes	No
6	Cause EUT to accept the call		
7	Verify the voice communication between EUT and QE1	Yes	No
Final verdict:			

6.7.1.3 Individual Safety calls

Interoperability Test Description			
Identifier:	TD_DSC_VHF_NDAP_0014		
Summary:	'Priority lower than Individual call'		
Configuration:	CF_1		
References:	ETSI EN 300 338-5 [1], clause 6.9		
Pre-test conditions:	EUT is busy with an Individual safety call		
Step	Test Sequence	Verdict	
		Pass	Fail
1	Cause QE1 to send an Individual Routine call to EUT		
2	Verify that EUT give a discrete audible alarm	Yes	No
3	Verify that EUT does not display that a call was received	Yes	No
4	Verify that EUT has logged the call from QE1	Yes	No
Final verdict:			

Interoperability Test Description			
Identifier:	TD_DSC_VHF_NDAP_0015		
Summary:	'Priority lower than Individual call'		
Configuration:	CF_1		
References:	ETSI EN 300 338-5 [1], clause 6.9		
Pre-test conditions:	EUT is busy with an Individual Safety call		
Step	Test Sequence	Verdict	
		Pass	Fail
1	Cause QE1 to send an Individual Safety call to EUT		
2	Verify that EUT give a discrete audible alarm	Yes	No
3	Verify that EUT does not display that a call was received	Yes	No
4	Verify that EUT has logged the call from QE1	Yes	No
Final verdict:			

Interoperability Test Description			
Identifier:	TD_DSC_VHF_NDAP_0016		
Summary:	'Priority higher than Individual call'		
Configuration:	CF_1		
References:	ETSI EN 300 338-5 [1], clause 6.9		
Pre-test conditions:	EUT is busy with an Individual Safety call		
Step	Test Sequence	Verdict	
		Pass	Fail
1	Cause QE1 to send an All Ships Safety call to EUT		
2	Verify that EUT give a discrete audible alarm	Yes	No
3	Verify that EUT displays what type of call is received	Yes	No
4	Verify that EUT displays the MMSI of QE1	Yes	No
5	Verify that EUT gives the option to accept or log the call	Yes	No
6	Cause EUT to accept the call		
7	Verify the voice communication between EUT and QE1	Yes	No
Final verdict:			

Interoperability Test Description			
Identifier:	TD_DSC_VHF_NDAP_0017		
Summary:	'Priority higher than Individual call'		
Configuration:	CF_1		
References:	ETSI EN 300 338-5 [1], clause 6.9		
Pre-test conditions:	EUT is busy with an Individual Safety call		
Step	Test Sequence	Verdict	
		Pass	Fail
1	Cause QE1 to send an Individual Urgency call to EUT		
2	Verify that EUT give a discrete audible alarm	Yes	No
3	Verify that EUT displays what type of call is received	Yes	No
4	Verify that EUT displays the MMSI of QE1	Yes	No
5	Verify that EUT gives the option to accept or log the call	Yes	No
6	Cause EUT to accept the call		
7	Verify the voice communication between EUT and QE1	Yes	No
Final verdict:			

Interoperability Test Description			
Identifier:	TD_DSC_VHF_NDAP_0018		
Summary:	'Priority higher than Individual call'		
Configuration:	CF_1		
References:	ETSI EN 300 338-5 [1], clause 6.9		
Pre-test conditions:	EUT is busy with an Individual Safety call		
Step	Test Sequence	Verdict	
		Pass	Fail
1	Cause QE1 to send an All Ships Urgency call to EUT		
2	Verify that EUT give a discrete audible alarm	Yes	No
3	Verify that EUT displays what type of call is received	Yes	No
4	Verify that EUT displays the MMSI of QE1	Yes	No
5	Verify that EUT gives the option to accept or log the call	Yes	No
6	Cause EUT to accept the call		
7	Verify the voice communication between EUT and QE1	Yes	No
Final verdict:			

Interoperability Test Description			
Identifier:	TD_DSC_VHF_NDAP_0019		
Summary:	'Priority higher than Individual call'		
Configuration:	CF_1		
References:	ETSI EN 300 338-5 [1], clause 6.9		
Pre-test conditions:	EUT is busy with an Individual Safety call		
Step	Test Sequence	Verdict	
		Pass	Fail
1	Cause QE1 to send a Distress category call to EUT		
2	Verify that EUT give a discrete audible alarm	Yes	No
3	Verify that EUT displays what type of call is received	Yes	No
4	Verify that EUT displays the MMSI of QE1	Yes	No
5	Verify that EUT gives the option to accept or log the call	Yes	No
6	Cause EUT to accept the call		
7	Verify the voice communication between EUT and QE1	Yes	No
Final verdict:			

6.7.1.4 All Ships Safety calls

Interoperability Test Description			
Identifier:	TD_DSC_VHF_NDAP_0020		
Summary:	'Priority lower than All Ships Safety call'		
Configuration:	CF_1		
References:	ETSI EN 300 338-5 [1], clause 6.9		
Pre-test conditions:	EUT is busy with an All Ships safety call		
Step	Test Sequence	Verdict	
		Pass	Fail
1	Cause QE1 to send an Individual Routine call to EUT		
2	Verify that EUT give a discrete audible alarm	Yes	No
3	Verify that EUT does not display that a call was received	Yes	No
4	Verify that EUT has logged the call from QE1	Yes	No
Final verdict:			

Interoperability Test Description			
Identifier:	TD_DSC_VHF_NDAP_0021		
Summary:	'Priority lower than All Ships Safety call'		
Configuration:	CF_1		
References:	ETSI EN 300 338-5 [1], clause 6.9		
Pre-test conditions:	EUT is busy with an All Ships safety call		
Step	Test Sequence	Verdict	
		Pass	Fail
1	Cause QE1 to send an Individual Safety call to EUT		
2	Verify that EUT give a discrete audible alarm	Yes	No
3	Verify that EUT does not display that a call was received	Yes	No
4	Verify that EUT has logged the call from QE1	Yes	No
Final verdict:			

Interoperability Test Description			
Identifier:	TD_DSC_VHF_NDAP_0022		
Summary:	'Priority lower than All Ships Safety call'		
Configuration:	CF_1		
References:	ETSI EN 300 338-5 [1], clause 6.9		
Pre-test conditions:	EUT is busy with an All Ships safety call		
Step	Test Sequence	Verdict	
		Pass	Fail
1	Cause QE1 to send an All Ships Safety call to EUT		
2	Verify that EUT give a discrete audible alarm	Yes	No
3	Verify that EUT does not display that a call was received	Yes	No
4	Verify that EUT has logged the call from QE1	Yes	No
Final verdict:			

Interoperability Test Description			
Identifier:	TD_DSC_VHF_NDAP_0023		
Summary:	'Priority higher than All Ships Safety call'		
Configuration:	CF_1		
References:	ETSI EN 300 338-5 [1], clause 6.9		
Pre-test conditions:	EUT is busy with an All Ships Safety call		
Step	Test Sequence	Verdict	
		Pass	Fail
1	Cause QE1 to send an Individual Urgency call to EUT		
2	Verify that EUT give a discrete audible alarm	Yes	No
3	Verify that EUT displays what type of call is received	Yes	No
4	Verify that EUT displays the MMSI of QE1	Yes	No
5	Verify that EUT gives the option to accept or log the call	Yes	No
6	Cause EUT to accept the call		
7	Verify the voice communication between EUT and QE1	Yes	No
Final verdict:			

Interoperability Test Description			
Identifier:	TD_DSC_VHF_NDAP_0024		
Summary:	'Priority higher than All Ships Safety call'		
Configuration:	CF_1		
References:	ETSI EN 300 338-5 [1], clause 6.9		
Pre-test conditions:	EUT is busy with an All Ships Safety call		
Step	Test Sequence	Verdict	
		Pass	Fail
1	Cause QE1 to send an All Ships Urgency call to EUT		
2	Verify that EUT give a discrete audible alarm	Yes	No
3	Verify that EUT displays what type of call is received	Yes	No
4	Verify that EUT displays the MMSI of QE1	Yes	No
5	Verify that EUT gives the option to accept or log the call	Yes	No
6	Cause EUT to accept the call		
7	Verify the voice communication between EUT and QE1	Yes	No
Final verdict:			

Interoperability Test Description			
Identifier:	TD_DSC_VHF_NDAP_0025		
Summary:	'Priority higher than All Ships Safety call'		
Configuration:	CF_1		
References:	ETSI EN 300 338-5 [1], clause 6.9		
Pre-test conditions:	EUT is busy with an All Ships Safety call		
Step	Test Sequence	Verdict	
		Pass	Fail
1	Cause QE1 to send a Distress category call to EUT		
2	Verify that EUT give a discrete audible alarm	Yes	No
3	Verify that EUT displays what type of call is received	Yes	No
4	Verify that EUT displays the MMSI of QE1	Yes	No
5	Verify that EUT gives the option to accept or log the call	Yes	No
6	Cause EUT to accept the call		
7	Verify the voice communication between EUT and QE1	Yes	No
Final verdict:			

6.7.1.5 Individual Urgency calls

Interoperability Test Description			
Identifier:	TD_DSC_VHF_NDAP_0026		
Summary:	'Priority lower than Individual Urgency call'		
Configuration:	CF_1		
References:	ETSI EN 300 338-5 [1], clause 6.9		
Pre-test conditions:	EUT is busy with an Individual Urgency call		
Step	Test Sequence	Verdict	
		Pass	Fail
1	Cause QE1 to send an Individual Routine call to EUT		
2	Verify that EUT give a discrete audible alarm	Yes	No
3	Verify that EUT does not display that a call was received	Yes	No
4	Verify that EUT has logged the call from QE1	Yes	No
Final verdict:			

Interoperability Test Description			
Identifier:	TD_DSC_VHF_NDAP_0027		
Summary:	'Priority lower than Individual Urgency call'		
Configuration:	CF_1		
References:	ETSI EN 300 338-5 [1], clause 6.9		
Pre-test conditions:	EUT is busy with an Individual Urgency call		
Step	Test Sequence	Verdict	
		Pass	Fail
1	Cause QE1 to send an Individual Safety call to EUT		
2	Verify that EUT give a discrete audible alarm	Yes	No
3	Verify that EUT does not display that a call was received	Yes	No
4	Verify that EUT has logged the call from QE1	Yes	No
Final verdict:			

Interoperability Test Description			
Identifier:	TD_DSC_VHF_NDAP_0028		
Summary:	'Priority lower than Individual Urgency call'		
Configuration:	CF_1		
References:	ETSI EN 300 338-5 [1], clause 6.9		
Pre-test conditions:	EUT is busy with an Individual Urgency call		
Step	Test Sequence	Verdict	
		Pass	Fail
1	Cause QE1 to send an All Ships Safety call to EUT		
2	Verify that EUT give a discrete audible alarm	Yes	No
3	Verify that EUT does not display that a call was received	Yes	No
4	Verify that EUT has logged the call from QE1	Yes	No
Final verdict:			

Interoperability Test Description			
Identifier:	TD_DSC_VHF_NDAP_0029		
Summary:	'Priority lower than Individual Urgency call'		
Configuration:	CF_1		
References:	ETSI EN 300 338-5 [1], clause 6.9		
Pre-test conditions:	EUT is busy with an Individual Urgency call		
Step	Test Sequence	Verdict	
		Pass	Fail
1	Cause QE1 to send an Individual Urgency call to EUT		
2	Verify that EUT give a discrete audible alarm	Yes	No
3	Verify that EUT does not display that a call was received	Yes	No
4	Verify that EUT has logged the call from QE1	Yes	No
Final verdict:			

Interoperability Test Description			
Identifier:	TD_DSC_VHF_NDAP_0030		
Summary:	'Priority higher than Individual Urgency call'		
Configuration:	CF_1		
References:	ETSI EN 300 338-5 [1], clause 6.9		
Pre-test conditions:	EUT is busy with an Individual Urgency call		
Step	Test Sequence	Verdict	
		Pass	Fail
1	Cause QE1 to send an All Ships Urgency call to EUT		
2	Verify that EUT give a discrete audible alarm	Yes	No
3	Verify that EUT displays what type of call is received	Yes	No
4	Verify that EUT displays the MMSI of QE1	Yes	No
5	Verify that EUT gives the option to accept or log the call	Yes	No
6	Cause EUT to accept the call		
7	Verify the voice communication between EUT and QE1	Yes	No
Final verdict:			

Interoperability Test Description			
Identifier:	TD_DSC_VHF_NDAP_0031		
Summary:	'Priority higher than Individual Urgency call'		
Configuration:	CF_1		
References:	ETSI EN 300 338-5 [1], clause 6.9		
Pre-test conditions:	EUT is busy with an Individual Urgency call		
Step	Test Sequence	Verdict	
		Pass	Fail
1	Cause QE1 to send a Distress category call to EUT		
2	Verify that EUT give a discrete audible alarm	Yes	No
3	Verify that EUT displays what type of call is received	Yes	No
4	Verify that EUT displays the MMSI of QE1	Yes	No
5	Verify that EUT gives the option to accept or log the call	Yes	No
6	Cause EUT to accept the call		
7	Verify the voice communication between EUT and QE1	Yes	No
Final verdict:			

6.7.1.6 All Ships Urgency calls

Interoperability Test Description			
Identifier:	TD_DSC_VHF_NDAP_0032		
Summary:	'Priority lower than All Ships Urgency call'		
Configuration:	CF_1		
References:	ETSI EN 300 338-5 [1], clause 6.9		
Pre-test conditions:	EUT is busy with an All Ships Urgency call		
Step	Test Sequence	Verdict	
		Pass	Fail
1	Cause QE1 to send an Individual Routine call to EUT		
2	Verify that EUT give a discrete audible alarm	Yes	No
3	Verify that EUT does not display that a call was received	Yes	No
4	Verify that EUT has logged the call from QE1	Yes	No
Final verdict:			

Interoperability Test Description			
Identifier:	TD_DSC_VHF_NDAP_0033		
Summary:	'Priority lower than All Ships Urgency call'		
Configuration:	CF_1		
References:	ETSI EN 300 338-5 [1], clause 6.9		
Pre-test conditions:	EUT is busy with an All Ships Urgency call		
Step	Test Sequence	Verdict	
		Pass	Fail
1	Cause QE1 to send an Individual Safety call to EUT		
2	Verify that EUT give a discrete audible alarm	Yes	No
3	Verify that EUT does not display that a call was received	Yes	No
4	Verify that EUT has logged the call from QE1	Yes	No
Final verdict:			

Interoperability Test Description			
Identifier:	TD_DSC_VHF_NDAP_0034		
Summary:	'Priority lower than All Ships Urgency call'		
Configuration:	CF_1		
References:	ETSI EN 300 338-5 [1], clause 6.9		
Pre-test conditions:	EUT is busy with an All Ships Urgency call		
Step	Test Sequence	Verdict	
		Pass	Fail
1	Cause QE1 to send an All Ships Safety call to EUT		
2	Verify that EUT give a discrete audible alarm	Yes	No
3	Verify that EUT does not display that a call was received	Yes	No
4	Verify that EUT has logged the call from QE1	Yes	No
Final verdict:			

Interoperability Test Description			
Identifier:	TD_DSC_VHF_NDAP_0035		
Summary:	'Priority lower than All Ships Urgency call'		
Configuration:	CF_1		
References:	ETSI EN 300 338-5 [1], clause 6.9		
Pre-test conditions:	EUT is busy with an All Ships Urgency call		
Step	Test Sequence	Verdict	
		Pass	Fail
1	Cause QE1 to send an Individual Urgency call to EUT		
2	Verify that EUT give a discrete audible alarm	Yes	No
3	Verify that EUT does not display that a call was received	Yes	No
4	Verify that EUT has logged the call from QE1	Yes	No
Final verdict:			

Interoperability Test Description			
Identifier:	TD_DSC_VHF_NDAP_0036		
Summary:	'Priority lower than All Ships Urgency call'		
Configuration:	CF_1		
References:	ETSI EN 300 338-5 [1], clause 6.9		
Pre-test conditions:	EUT is busy with an All Ships Urgency call		
Step	Test Sequence	Verdict	
		Pass	Fail
1	Cause QE1 to send an All Ships Urgency call to EUT		
2	Verify that EUT give a discrete audible alarm	Yes	No
3	Verify that EUT does not display that a call was received	Yes	No
4	Verify that EUT has logged the call from QE1	Yes	No
Final verdict:			

Interoperability Test Description			
Identifier:	TD_DSC_VHF_NDAP_0037		
Summary:	'Priority higher than All Ships Urgency call'		
Configuration:	CF_1		
References:	ETSI EN 300 338-5 [1], clause 6.9		
Pre-test conditions:	EUT is busy with an All Ships Urgency call		
Step	Test Sequence	Verdict	
		Pass	Fail
1	Cause QE1 to send a Distress category call to EUT		
2	Verify that EUT give a discrete audible alarm	Yes	No
3	Verify that EUT displays what type of call is received	Yes	No
4	Verify that EUT displays the MMSI of QE1	Yes	No
5	Verify that EUT gives the option to accept or log the call	Yes	No
6	Cause EUT to accept the call		
7	Verify the voice communication between EUT and QE1	Yes	No
Final verdict:			

6.7.1.7 All Ships distress calls

Interoperability Test Description			
Identifier:	TD_DSC_VHF_NDAP_0046		
Summary:	'Priority lower than All Ships distress call'		
Configuration:	CF_1		
References:	ETSI EN 300 338-5 [1], clause 6.9		
Pre-test conditions:	EUT is busy with an All Ships distress call		
Step	Test Sequence	Verdict	
		Pass	Fail
1	Cause QE1 to send an Individual Routine call to EUT		
2	Verify that EUT give a discrete audible alarm	Yes	No
3	Verify that EUT does not display that a call was received	Yes	No
4	Verify that EUT has logged the call from QE1	Yes	No
Final verdict:			

Interoperability Test Description			
Identifier:	TD_DSC_VHF_NDAP_0047		
Summary:	'Priority lower than All Ships distress call'		
Configuration:	CF_1		
References:	ETSI EN 300 338-5 [1], clause 6.9		
Pre-test conditions:	EUT is busy with an All Ships distress call		
Step	Test Sequence	Verdict	
		Pass	Fail
1	Cause QE1 to send an Individual Safety call to EUT		
2	Verify that EUT give a discrete audible alarm	Yes	No
3	Verify that EUT does not display that a call was received	Yes	No
4	Verify that EUT has logged the call from QE1	Yes	No
Final verdict:			

Interoperability Test Description			
Identifier:	TD_DSC_VHF_NDAP_0048		
Summary:	'Priority lower than All Ships distress call'		
Configuration:	CF_1		
References:	ETSI EN 300 338-5 [1], clause 6.9		
Pre-test conditions:	EUT is busy with an All Ships distress call		
Step	Test Sequence	Verdict	
		Pass	Fail
1	Cause QE1 to send an All Ships Safety call to EUT		
2	Verify that EUT give a discrete audible alarm	Yes	No
3	Verify that EUT does not display that a call was received	Yes	No
4	Verify that EUT has logged the call from QE1	Yes	No
Final verdict:			

Interoperability Test Description			
Identifier:	TD_DSC_VHF_NDAP_0049		
Summary:	'Priority lower than All Ships distress call'		
Configuration:	CF_1		
References:	ETSI EN 300 338-5 [1], clause 6.9		
Pre-test conditions:	EUT is busy with an All Ships distress call		
Step	Test Sequence	Verdict	
		Pass	Fail
1	Cause QE1 to send an Individual Urgency call to EUT		
2	Verify that EUT give a discrete audible alarm	Yes	No
3	Verify that EUT does not display that a call was received	Yes	No
4	Verify that EUT has logged the call from QE1	Yes	No
Final verdict:			

Interoperability Test Description			
Identifier:	TD_DSC_VHF_NDAP_0050		
Summary:	'Priority lower than All Ships distress call'		
Configuration:	CF_1		
References:	ETSI EN 300 338-5 [1], clause 6.9		
Pre-test conditions:	EUT is busy with an All Ships distress call		
Step	Test Sequence	Verdict	
		Pass	Fail
1	Cause QE1 to send an All Ships Urgency call to EUT		
2	Verify that EUT give a discrete audible alarm	Yes	No
3	Verify that EUT does not display that a call was received	Yes	No
4	Verify that EUT has logged the call from QE1	Yes	No
Final verdict:			

Interoperability Test Description			
Identifier:	TD_DSC_VHF_NDAP_0051		
Summary:	'Priority lower than All Ships distress call'		
Configuration:	CF_1		
References:	ETSI EN 300 338-5 [1], clause 6.9		
Pre-test conditions:	EUT is busy with an All Ships distress call		
Step	Test Sequence	Verdict	
		Pass	Fail
1	Cause QE1 to send an Individual distress call to EUT		
2	Verify that EUT give a discrete audible alarm	Yes	No
3	Verify that EUT does not display that a call was received	Yes	No
4	Verify that EUT has logged the call from QE1	Yes	No
Final verdict:			

Interoperability Test Description			
Identifier:	TD_DSC_VHF_NDAP_0052		
Summary:	'Priority lower than All Ships distress call'		
Configuration:	CF_1		
References:	ETSI EN 300 338-5 [1], clause 6.9		
Pre-test conditions:	EUT is busy with an All Ships distress call		
Step	Test Sequence	Verdict	
		Pass	Fail
1	Cause QE1 to send an All Ships distress call to EUT		
2	Verify that EUT give a discrete audible alarm	Yes	No
3	Verify that EUT does not display that a call was received	Yes	No
4	Verify that EUT has logged the call from QE1	Yes	No
Final verdict:			

Interoperability Test Description			
Identifier:	TD_DSC_VHF_NDAP_0053		
Summary:	'Priority lower than All Ships distress call'		
Configuration:	CF_1		
References:	ETSI EN 300 338-5 [1], clause 6.9		
Pre-test conditions:	EUT has the option to receive all ships distress relays EUT is busy with an All Ships distress call		
Step	Test Sequence	Verdict	
		Pass	Fail
1	Cause QE1 to send an All Ships distress relay call to EUT		
2	Verify that EUT give a discrete audible alarm	Yes	No
3	Verify that EUT does not display that a call was received	Yes	No
4	Verify that EUT has logged the call from QE1	Yes	No
Final verdict:			

6.7.2 Automated procedure tests

Interoperability Test Description			
Identifier:	TD_DSC_VHF_NDAP_0054		
Summary:	"Able to comply" test without frequency change		
Configuration:	CF_1		
References:	ETSI EN 300 338-5 [1], clauses 6.6.2 and 6.6.3		
Pre-test conditions:			
Step	Test Sequence	Verdict	
		Pass	Fail
1	From the EUT send a DSC message of routine priority requesting radiotelephone addressed to QE1		
2	Verify that the EUT indicates that it is transmitting	Yes	No
3	Verify that the information content of the initial DSC message is displayed or available for display on the EUT	Yes	No
4	Verify that upon completion of the transmission the EUT states that it is waiting for an acknowledgement	Yes	No
5	Verify that the EUT displays the time since sending the initial DSC message	Yes	No
6	Verify that the option to resend the initial DSC message is available on the EUT	Yes	No
7	IF the EUT has multiple procedures, verify that the option to place the procedure on hold is available on the EUT	Yes	No
8	Verify that the option to terminate the procedure is available on the EUT	Yes	No
9	Acknowledge the DSC message from the QE1 with "able to comply".		
10	Verify that the routine acknowledgement alarm sounds on the EUT	Yes	No
11	Verify that the EUT indicates that it has been acknowledged or that communications are ready	Yes	No
12	Verify that the time since being acknowledged is displayed on the EUT	Yes	No
13	Verify that the option to resend the initial DSC message is no longer available on the EUT	Yes	No
14	Verify that the option to place the procedure on hold is available on the EUT	Yes	No
15	Verify that the option to terminate the procedure is available on the EUT	Yes	No
16	Verify that you can speak to the QE1 from the EUT	Yes	No
17	Verify that you can speak to the EUT from the QE1	Yes	No
Final verdict:			

Interoperability Test Description			
Identifier:	TD_DSC_VHF_NDAP_0055		
Summary:	"Able to comply" test with frequency change		
Configuration:	CF_1		
References:6	ETSI EN 300 338-5 [1], clauses 6.6.2 and 6.6.3		
Pre-test conditions:			
Step	Test Sequence	Verdict	
		Pass	Fail
1	From the EUT send a DSC message of routine priority requesting radiotelephone addressed to QE1		
2	Verify that the EUT indicates that it is transmitting	Yes	No
3	Verify that the information content of the initial DSC message is displayed or available for display on the EUT	Yes	No
4	Verify that upon completion of the transmission the EUT states that it is waiting for an acknowledgement	Yes	No
5	Verify that the EUT displays the time since sending the initial DSC message	Yes	No
6	Verify that the option to resend the initial DSC message is available on the EUT	Yes	No
7	IF the EUT has multiple procedures, verify that the option to place the procedure on hold is available on the EUT	Yes	No
8	Verify that the option to terminate the procedure is available on the EUT	Yes	No
9	Acknowledge the DSC message from the QE1 with "able to comply" involving also a frequency change		
10	Verify that the routine acknowledgement alarm sounds on the EUT	Yes	No
11	Verify that the EUT indicates that it has been acknowledged or that communications are ready	Yes	No
12	Verify that the time since being acknowledged is displayed on the EUT	Yes	No
13	Verify that the option to resend the initial DSC message is no longer available on the EUT	Yes	No
14	Verify that the option to place the procedure on hold is available on the EUT	Yes	No
15	Verify that the option to terminate the procedure is available on the EUT	Yes	No
16	Verify that you can speak to the QE1 from the EUT	Yes	No
17	Verify that you can speak to the EUT from the QE1	Yes	No
Final verdict:			

Interoperability Test Description			
Identifier:	TD_DSC_VHF_NDAP_0056		
Summary:	Test of sending non distress procedure sequence with no acknowledgement required		
Configuration:	CF_1		
References:	ETSI EN 300 338-5 [1], clauses 6.6.2 and 6.6.3		
Pre-test conditions:			
Step	Test Sequence	Verdict	
		Pass	Fail
1	From the EUT send an All ships DSC message with priority urgency requesting radio telephone		
2	Verify that the EUT indicates that it is transmitting	Yes	No
3	Verify that the information content of the initial DSC message is displayed or available for display on the EUT	Yes	No
4	Verify that upon completion of the transmission the EUT states that the procedure is done	Yes	No
5	Verify that the EUT displays the time since sending the initial DSC message	Yes	No
6	Verify that the option to resend the initial DSC message is available on the EUT	Yes	No
7	IF the EUT has multiple procedures, verify that the option to place the procedure on hold is available on the EUT	Yes	No
8	Verify that the option to terminate the procedure is available on the EUT	Yes	No
9	Verify that you can speak to the QE1 from the EUT	Yes	No
10	Verify that you can speak to the EUT from the QE1	Yes	No
Final verdict:			

6.7.3 Timeout tests

Interoperability Test Description			
Identifier:	TD_DSC_VHF_NDAP_0057		
Summary:	Timeout testing of Individual call automated procedure		
Configuration:	CF_1		
References:	ETSI EN 300 338-5 [1], clauses 6.5.3 and 6.5.9		
Pre-test conditions:			
Step	Test Sequence	Verdict	
		Pass	Fail
1	Set the no activity timeout of non-distress DSC automated procedures to some value in the range [10 seconds to 10 minutes]		
2	Cause the TE to send an Individual routine call to the EUT		
3	Wait until the no activity timer defined in step 1 almost expires		
4	Verify that at least 10 seconds prior to automated termination a visual and aural warning is given by the EUT, indicating the nearing no activity timeout	Yes	No
5	Verify that the EUT provides the means to silence the above alarm	Yes	No
6	Verify that the EUT provides the means to stop the upcoming 'no activity termination' of the automated procedure	Yes	No
Final verdict:			

Interoperability Test Description			
Identifier:	TD_DSC_VHF_NDAP_0058		
Summary:	Timeout testing of Individual safety call automated procedure		
Configuration:	CF_1		
References:	ETSI EN 300 338-5 [1], clauses 6.5.3 and 6.5.9		
Pre-test conditions:			
Step	Test Sequence	Verdict	
		Pass	Fail
1	Set the no activity timeout of non-distress DSC automated procedures to some value in the range [10 seconds to 10 minutes]		
2	Cause the TE to send an Individual safety call to the EUT		
3	Wait until the no activity timer defined in step 1 almost expires		
4	Verify that at least 10 seconds prior to automated termination a visual and aural warning is given by the EUT, indicating the nearing no activity timeout	Yes	No
5	Verify that the EUT provides the means to silence the above alarm	Yes	No
6	Verify that the EUT provides the means to stop the upcoming 'no activity termination' of the automated procedure	Yes	No
Final verdict:			

Interoperability Test Description			
Identifier:	TD_DSC_VHF_NDAP_0059		
Summary:	Timeout testing of All ships safety call automated procedure		
Configuration:	CF_1		
References:	ETSI EN 300 338-5 [1], clauses 6.5.3 and 6.5.9		
Pre-test conditions:			
Step	Test Sequence	Verdict	
		Pass	Fail
1	Set the no activity timeout of non-distress DSC automated procedures to some value in the range [10 seconds to 10 minutes]		
2	Cause the TE to send an All ships safety call		
3	Wait until the no activity timer defined in step 1 almost expires		
4	Verify that at least 10 seconds prior to automated termination a visual and aural warning is given by the EUT, indicating the nearing no activity timeout	Yes	No
5	Verify that the EUT provides the means to silence the above alarm	Yes	No
6	Verify that the EUT provides the means to stop the upcoming 'no activity termination' of the automated procedure	Yes	No
Final verdict:			

Interoperability Test Description			
Identifier:	TD_DSC_VHF_NDAP_0060		
Summary:	Timeout testing of Individual Urgency call automated procedure		
Configuration:	CF_1		
References:	ETSI EN 300 338-5 [1], clauses 6.5.3 and 6.5.9		
Pre-test conditions:			
Step	Test Sequence	Verdict	
		Pass	Fail
1	Set the no activity timeout of non-distress DSC automated procedures to some value in the range [10 seconds to 10 minutes]		
2	Cause the TE to send an Individual Urgency call to the EUT		
3	Wait until the no activity timer defined in step 1 almost expires		
4	Verify that at least 10 seconds prior to automated termination a visual and aural warning is given by the EUT, indicating the nearing no activity timeout	Yes	No
5	Verify that the EUT provides the means to silence the above alarm	Yes	No
6	Verify that the EUT provides the means to stop the upcoming 'no activity termination' of the automated procedure	Yes	No
Final verdict:			

Interoperability Test Description			
Identifier:	TD_DSC_VHF_NDAP_0061		
Summary:	Timeout testing of All Ships Urgency call automated procedure		
Configuration:	CF_1		
References:	ETSI EN 300 338-5 [1], clauses 6.5.3 and 6.5.9		
Pre-test conditions:			
Step	Test Sequence	Verdict	
		Pass	Fail
1	Set the no activity timeout of non-distress DSC automated procedures to some value in the range [10 seconds to 10 minutes]		
2	Cause the TE to send an All Ships Urgency call		
3	Wait until the no activity timer defined in step 1 almost expires		
4	Verify that at least 10 seconds prior to automated termination a visual and aural warning is given by the EUT, indicating the nearing no activity timeout	Yes	No
5	Verify that the EUT provides the means to silence the above alarm	Yes	No
6	Verify that the EUT provides the means to stop the upcoming 'no activity termination' of the automated procedure	Yes	No
Final verdict:			

6.8 Other calls

Interoperability Test Description			
Identifier:	TD_DSC_VHF_OC_0001		
Summary:	'Sending Individual test call'		
Configuration:	CF_1		
References:	ETSI EN 300 338-5 [1], clause 6.9.2.2		
Pre-test conditions:	EUT has the optional test call available QE1 and EUT in standby on CH:16		
Step	Test Sequence	Verdict	
		Pass	Fail
1	On EUT select 'Call' then select 'Test Call'		
2	Enter/select MMSI of QE1		
3	Cause EUT to send the call		
4	Verify that ACK is received from QE1	Yes	No
Final verdict:			

Interoperability Test Description			
Identifier:	TD_DSC_VHF_OC_0002		
Summary:	'Receiving Individual test call'		
Configuration:	CF_1		
References:	ETSI EN 300 338-5 [1], clause 6.9.2.2		
Pre-test conditions:	EUT has the optional test call available QE1 and EUT in standby on CH:16		
Step	Test Sequence	Verdict	
		Pass	Fail
1	On QE1 select 'Call' then select 'Test Call'		
2	Enter/select MMSI of EUT		
3	Cause QE1 to send the call		
4	Verify that ACK is received from EUT	Yes	No
Final verdict:			

6.9 Interface and other functions

6.9.0 Display

Interoperability Test Description			
Identifier:	TD_DSC_VHF_IOF_0001		
Summary:	Primary DSC alphanumeric display test		
Configuration:	CF_1		
References:	ETSI EN 300 338-5 [1], clause 4.1.1		
Pre-test conditions:			
Step	Test Sequence	Verdict	
		Pass	Fail
1	Verify that EUT displays at a minimum a total number of 32 characters	Yes	No
2	Verify that EUT displays the number of lines	Yes	No
3	Verify that on the EUT's display the minimum number of characters per line is 12	Yes	No
4	Verify that on the EUT that any displayed information is static	Yes	
5	Verify that on the EUT horizontal scrolling techniques are not permitted	Yes	No
Final verdict:			

Interoperability Test Description			
Identifier:	TD_DSC_VHF_IOF_0002		
Summary:	Displaying all the user programmable information content of a DSC call		
Configuration:	CF_1		
References:	ETSI EN 300 338-5 [1], clause 6.3		
Pre-test conditions:			
Step	Test Sequence	Verdict	
		Pass	Fail
1	Verify that EUT is capable of displaying its station MMSI	Yes	No
2	Verify that EUT is capable of displaying its latest position of the vessel	Yes	No
3	Verify that EUT is capable of displaying the UTC time of its latest position	Yes	No
Final verdict:			

6.9.1 Alarms in standby mode

Interoperability Test Description			
Identifier:	TD_DSC_VHF_IOF_0003		
Summary:	Visual and aural alarm for Distress count		
Configuration:	CF_2		
References:	ETSI EN 300 338-5 [1], clauses 6.2.3 and C.1		
Pre-test conditions:			
Step	Test Sequence	Verdict	
		Pass	Fail
1	On EUT push Distress Button		
2	Verify that EUT sounds the count alarm	Yes	No
3	Verify that EUT stops the alarm when QE1 receives the alert	Yes	No
Final verdict:			

Interoperability Test Description			
Identifier:	TD_DSC_VHF_IOF_0004		
Summary:	Visual and aural alarm for Distress alert - Timeout cancellation		
Configuration:	CF_2		
References:	ETSI EN 300 338-5 [1], clauses 6.2.3 and C.1		
Pre-test conditions:			
Step	Test Sequence	Verdict	
		Pass	Fail
1	On QE1 push Distress Button		
2	Release the distress button after the countdown is complete		
3	Verify that EUT receives the alert	Yes	No
4	Verify that EUT provides both a visual and aural alarm component	Yes	No
5	Verify that EUT provides the reason for the alarm	Yes	No
6	Verify that EUT initially is of a loudness that is clearly distinguishable for first 10 seconds	Yes	No
7	Verify that EUT's alarm starts softly to rise within next 10 seconds	Yes	No
8	Do not cancel the alarm manually		
9	Verify that EUT cancels the alarm automatically after 2 minutes	Yes	No
Final verdict:			

Interoperability Test Description			
Identifier:	TD_DSC_VHF_IOF_0005		
Summary:	Visual and aural alarm for Distress alert - Manual cancellation		
Configuration:	CF_2		
References:	ETSI EN 300 338-5 [1], clauses 6.2.3 and C.1		
Pre-test conditions:			
Step	Test Sequence	Verdict	
		Pass	Fail
1	On QE1 push Distress Button		
2	Release the distress button after the countdown is complete		
3	Verify that EUT receives the alert	Yes	No
4	Verify that EUT provides both a visual and aural alarm component	Yes	No
5	Verify that EUT provides the reason for the alarm	Yes	No
6	Verify that EUT initially is of a loudness that is clearly distinguishable for first 10 seconds	Yes	No
7	Verify that EUT's alarm starts softly to rise within next 10 seconds	Yes	No
8	Cancel the alarm manually		
9	Verify that EUT stops visual and aural alarm component	Yes	No
Final verdict:			

Interoperability Test Description			
Identifier:	TD_DSC_VHF_IOF_0006		
Summary:	Visual and aural alarm for Distress acknowledgement - Timeout cancellation		
Configuration:	CF_2		
References:	ETSI EN 300 338-5 [1], clauses 6.2.3 and C.1		
Pre-test conditions:			
Step	Test Sequence	Verdict	
		Pass	Fail
1	On EUT push Distress Button		
2	Release the distress button after the countdown is complete		
3	Verify that QE1 receives the alert	Yes	No
4	Cause QE1 to acknowledge the alert		
5	Verify that EUT sounds and displays the distress ack alarm	Yes	No
6	Do not cancel the alarm manually		
7	Verify that EUT cancels the alarm automatically after 2 minutes	Yes	No
Final verdict:			

Interoperability Test Description			
Identifier:	TD_DSC_VHF_IOF_0007		
Summary:	Visual and aural alarm for Distress acknowledgement - Manual cancellation		
Configuration:	CF_2		
References:	ETSI EN 300 338-5 [1], clauses 6.2.3 and C.1		
Pre-test conditions:			
Step	Test Sequence	Verdict	
		Pass	Fail
1	On EUT push Distress Button		
2	Release the distress button after the countdown is complete		
3	Verify that QE1 receives the alert	Yes	No
4	Cause QE1 to acknowledge the alert		
5	Verify that EUT sounds and displays the distress ack alarm	Yes	No
6	Cancel the alarm manually		
7	Verify that EUT stops visual and aural alarm component	Yes	No
Final verdict:			

Interoperability Test Description			
Identifier:	TD_DSC_VHF_IOF_0008		
Summary:	Visual and aural alarm for Distress relay RT Individual - Manual cancellation		
Configuration:	CF_4		
References:	ETSI EN 300 338-5 [1], clauses 6.2.3 and C.1		
Pre-test conditions:	EUT has this option		
Step	Test Sequence	Verdict	
		Pass	Fail
1	On QE2 push Distress Button		
2	Release the distress button after the countdown is complete		
3	Verify that QE1 receives the alert and cause it to relay the alert to EUT	Yes	No
4	Verify that EUT receives the alert	Yes	No
5	Verify that EUT provides both a visual and aural alarm component	Yes	No
6	Verify that EUT provides the reason for the alarm	Yes	No
7	Verify that EUT initially is of a loudness that is clearly distinguishable for first 10 seconds	Yes	No
8	Verify that EUT's alarm starts softly to rise within next 10 seconds	Yes	No
9	Cancel the alarm manually		
10	Verify that EUT stops visual and aural alarm component	Yes	No
Final verdict:			

Interoperability Test Description			
Identifier:	TD_DSC_VHF_IOF_0009		
Summary:	Visual and aural alarm for Distress relay RT All ships - Manual cancellation		
Configuration:	CF_4		
References:	ETSI EN 300 338-5 [1], clauses 6.2.3 and C.1		
Pre-test conditions:	EUT has this option		
Step	Test Sequence	Verdict	
		Pass	Fail
1	On QE2 push Distress Button		
2	Release the distress button after the countdown is complete		
3	Verify that QE1 receives the alert and cause it to relay the alert to 'all ships' address	Yes	No
4	Verify that EUT receives the alert	Yes	No
5	Verify that EUT provides both a visual and aural alarm component	Yes	No
6	Verify that EUT provides the reason for the alarm	Yes	No
7	Verify that EUT initially is of a loudness that is clearly distinguishable for first 10 seconds	Yes	No
8	Verify that EUT's alarm starts softly to rise within next 10 seconds	Yes	No
9	Cancel the alarm manually		
10	Verify that EUT stops visual and aural alarm component	Yes	No
Final verdict:			

Interoperability Test Description			
Identifier:	TD_DSC_VHF_IOF_0010		
Summary:	Visual and aural alarm for Distress relay ACK Individual - Manual cancellation		
Configuration:	CF_6		
References:	ETSI EN 300 338-5 [1], clauses 6.2.3 and C.1		
Pre-test conditions:	EUT has this option		
Step	Test Sequence	Verdict	
		Pass	Fail
1	On QE3 push Distress Button		
2	Release the distress button after the countdown is complete		
3	Verify that QE3 receives the alert and cause it to relay the alert to 'all ships' address		
4	Verify that QE2 receives the alert relay		
5	Cause QE2 to acknowledge the alert relay		
6	Verify that EUT sounds and displays the distress ack alarm	Yes	No
7	Cancel the alarm manually		
8	Verify that EUT stops visual and aural alarm component	Yes	No
Final verdict:			

Interoperability Test Description			
Identifier:	TD_DSC_VHF_IOF_0011		
Summary:	Visual and aural alarm for 'All ships RT call - Urgency' - Timeout cancellation		
Configuration:	CF_2		
References:	ETSI EN 300 338-5 [1], clauses 6.2.3 and C.1		
Pre-test conditions:			
Step	Test Sequence	Verdict	
		Pass	Fail
1	On QE1 select 'Call' then select 'All Ships - Urgency'		
2	Accept the proposed channel		
3	Cause QE1 to send the call		
4	Verify that EUT receives the call	Yes	No
5	Verify that EUT provides both a visual and aural alarm component	Yes	No
6	Verify that EUT's alarm starts softly to rise within next 10 seconds	Yes	No
7	Verify that EUT provides the reason for the alarm	Yes	No
8	Verify that EUT cancels the alarm automatically after 2 minutes	Yes	No
Final verdict:			

Interoperability Test Description			
Identifier:	TD_DSC_VHF_IOF_0012		
Summary:	Visual and aural alarm for 'All ships RT call - Urgency' - Manual cancellation		
Configuration:	CF_2		
References:	ETSI EN 300 338-5 [1], clauses 6.2.3 and C.1		
Pre-test conditions:			
Step	Test Sequence	Verdict	
		Pass	Fail
1	On QE1 select 'Call' then select 'All Ships - Urgency'		
2	Accept the proposed channel		
3	Cause QE1 to send the call		
4	Verify that EUT receives the call	Yes	No
5	Verify that EUT provides both a visual and aural alarm component	Yes	No
6	Verify that EUT provides the reason for the alarm	Yes	No
7	Verify that EUT's alarm starts softly to rise within next 10 seconds	Yes	No
8	Cancel the alarm manually		
9	Verify that EUT stops visual and aural alarm component	Yes	No
Final verdict:			

Interoperability Test Description			
Identifier:	TD_DSC_VHF_IOF_0013		
Summary:	Visual and aural alarm for 'All ships RT call - Safety' - Automatic cancellation		
Configuration:	CF_2		
References:	ETSI EN 300 338-5 [1], clauses 6.2.3 and C.1		
Pre-test conditions:			
Step	Test Sequence	Verdict	
		Pass	Fail
1	On QE1 select 'Call' then select 'All Ships - Safety'		
2	Accept the proposed channel		
3	Cause QE1 to send the call		
4	Verify that EUT receives the call	Yes	No
5	Verify that EUT provides both a visual and aural alarm component	Yes	No
6	Verify that EUT's alarm starts softly to rise within next 10 seconds	Yes	No
7	Verify that EUT provides the reason for the alarm	Yes	No
8	Verify that EUT cancels the alarm automatically	Yes	No
Final verdict:			

Interoperability Test Description			
Identifier:	TD_DSC_VHF_IOF_0014		
Summary:	Visual and aural alarm for 'Individual RT call- Urgency' - Timeout cancellation		
Configuration:	CF_2		
References:	ETSI EN 300 338-5 [1], clauses 6.2.3 and C.1		
Pre-test conditions:			
Step	Test Sequence	Verdict	
		Pass	Fail
1	On QE1 select 'Call' then select 'Individual - Urgency'		
2	Accept the proposed channel		
3	Enter/select MMSI of EUT		
4	Accept the proposed channel		
5	Cause QE1 to send the call to EUT		
6	Verify that EUT receives the call	Yes	No
7	Verify that EUT provides both a visual and aural alarm component	Yes	No
8	Verify that EUT's alarm starts softly to rise within next 10 seconds	Yes	No
9	Verify that EUT provides the reason for the alarm	Yes	No
10	Verify that EUT cancels the alarm automatically after 2 minutes	Yes	No
Final verdict:			

Interoperability Test Description			
Identifier:	TD_DSC_VHF_IOF_0015		
Summary:	Visual and aural alarm for 'Individual RT call- Urgency' - Manual cancellation		
Configuration:	CF_2		
References:	ETSI EN 300 338-5 [1], clauses 6.2.3 and C.1		
Pre-test conditions:			
Step	Test Sequence	Verdict	
		Pass	Fail
1	On QE1 select 'Call' then select 'Individual - Urgency'		
2	Accept the proposed channel		
3	Enter/select MMSI of EUT		
4	Accept the proposed channel		
5	Cause QE1 to send the call to EUT		
6	Verify that EUT receives the call	Yes	No
7	Verify that EUT provides both a visual and aural alarm component	Yes	No
8	Verify that EUT provides the reason for the alarm	Yes	No
9	Verify that EUT's alarm starts softly to rise within next 10 seconds	Yes	No
10	Cancel the alarm manually		
11	Verify that EUT stops visual and aural alarm component	Yes	No
Final verdict:			

Interoperability Test Description			
Identifier:	TD_DSC_VHF_IOF_0016		
Summary:	Visual and aural alarm for 'Individual RT call - Safety' - Automatic cancellation		
Configuration:	CF_2		
References:	ETSI EN 300 338-5 [1], clauses 6.2.3 and C.1		
Pre-test conditions:			
Step	Test Sequence	Verdict	
		Pass	Fail
1	On QE1 select 'Call' then select 'Individual - Safety'		
2	Accept the proposed channel		
3	Enter/select MMSI of EUT		
4	Accept the proposed channel		
5	Cause QE1 to send the call to EUT		
6	Verify that EUT receives the call	Yes	No
7	Verify that EUT provides both a visual and aural alarm component	Yes	No
8	Verify that EUT's alarm starts softly to rise within next 10 seconds	Yes	No
9	Verify that EUT provides the reason for the alarm	Yes	No
10	Verify that EUT cancels the alarm automatically	Yes	No
Final verdict:			

Interoperability Test Description			
Identifier:	TD_DSC_VHF_IOF_0017		
Summary:	Visual and aural alarm for Individual test call -Safety		
Configuration:	CF_2		
References:	ETSI EN 300 338-5 [1], clauses 6.2.3 and C.1		
Pre-test conditions:	EUT has this option		
Step	Test Sequence	Verdict	
		Pass	Fail
1	On QE1 select 'Call' then select 'Test - Safety'		
2	Enter/select MMSI of EUT		
3	Accept the proposed channel		
4	Cause QE1 to send the individual call to EUT		
5	Verify that EUT receives the call	Yes	No
6	Verify that EUT provides both a visual and aural alarm component	Yes	No
7	Verify that EUT provides the reason for the alarm	Yes	No
8	Verify that EUT cancels the alarm automatically	Yes	No
Final verdict:			

Interoperability Test Description			
Identifier:	TD_DSC_VHF_IOF_0018		
Summary:	Visual and aural alarm for Individual test call ACK -Safety		
Configuration:	CF_2		
References:	ETSI EN 300 338-5 [1], clauses 6.2.3 and C.1		
Pre-test conditions:	EUT has this option		
Step	Test Sequence	Verdict	
		Pass	Fail
1	On EUT select 'Call' then select 'Test - Safety'		
2	Enter/select MMSI of QE1		
3	Accept the proposed channel		
4	Cause EUT to send the individual call to QE1		
5	Verify that QE1 receives the call	Yes	No
6	Cause QE1 to acknowledge the call		
7	Verify that EUT sounds and displays the ack alarm	Yes	No
8	Verify that EUT cancels the alarm automatically	Yes	No
Final verdict:			

Interoperability Test Description			
Identifier:	TD_DSC_VHF_IOF_0019		
Summary:	Visual and aural alarm for Group call - Routine		
Configuration:	CF_2		
References:	ETSI EN 300 338-5 [1], clauses 6.2.3 and C.1		
Pre-test conditions:			
Step	Test Sequence	Verdict	
		Pass	Fail
1	On QE1 select 'Call' then select 'Group Call'		
2	Enter/select Group MMSI to which EUT belongs		
3	Accept the proposed channel		
4	Cause QE1 to send the individual call to EUT		
5	Verify that EUT receives the call	Yes	No
6	Verify that EUT provides both a visual and aural alarm component	Yes	No
7	Verify that EUT provides the reason for the alarm	Yes	No
8	Verify that EUT cancels the alarm automatically	Yes	No
Final verdict:			

Interoperability Test Description			
Identifier:	TD_DSC_VHF_IOF_0020		
Summary:	Visual and aural alarm for Individual call - Routine		
Configuration:	CF_2		
References:	ETSI EN 300 338-5 [1], clauses 6.2.3 and C.1		
Pre-test conditions:			
Step	Test Sequence	Verdict	
		Pass	Fail
1	On QE1 select 'Call' then select 'Individual - Routine'		
2	Enter/select MMSI of EUT		
3	Accept the proposed channel		
4	Cause QE1 to send the individual call to EUT		
5	Verify that EUT receives the call	Yes	No
6	Verify that EUT provides both a visual and aural alarm component	Yes	No
7	Verify that EUT provides the reason for the alarm	Yes	No
8	Verify that EUT cancels the alarm automatically	Yes	No
Final verdict:			

Interoperability Test Description			
Identifier:	TD_DSC_VHF_IOF_021		
Summary:	Visual and aural alarm for Individual call ACK -Safety		
Configuration:	CF_2		
References:	ETSI EN 300 338-5 [1], clauses 6.2.3 and C.1		
Pre-test conditions:			
Step	Test Sequence	Verdict	
		Pass	Fail
1	On EUT select 'Call' then select 'Individual - Safety'		
2	Enter/select MMSI of QE1		
3	Accept the proposed channel		
4	Cause EUT to send the individual call to QE1		
5	Verify that QE1 receives the call	Yes	No
6	Cause QE1 to acknowledge the call		
7	Verify that EUT sounds and displays the ack alarm	Yes	No
8	Verify that EUT cancels the alarm automatically	Yes	No
Final verdict:			

Interoperability Test Description			
Identifier:	TD_DSC_VHF_IOF_0022		
Summary:	Visual and aural alarm for Distress Alert Cancel - Timeout cancellation		
Configuration:	CF_2		
References:	ETSI EN 300 338-5 [1], clauses 6.2.3 and C.1		
Pre-test conditions:			
Step	Test Sequence	Verdict	
		Pass	Fail
1	On QE1 push Distress Button		
2	Release the distress button after the countdown is complete		
3	Verify that EUT receives the alert	Yes	No
4	Cause QE1 to cancel the alert		
5	Verify that EUT provides both a visual and aural alarm cancellation component	Yes	No
6	Verify that EUT cancels the alarm automatically after 2 minutes	Yes	No
Final verdict:			

Interoperability Test Description			
Identifier:	TD_DSC_VHF_IOF_0023		
Summary:	Visual and aural alarm for Distress Alert Cancel - Manual cancellation		
Configuration:	CF_2		
References:	ETSI EN 300 338-5 [1], clauses 6.2.3 and C.1		
Pre-test conditions:			
Step	Test Sequence	Verdict	
		Pass	Fail
1	On QE1 push Distress Button		
2	Release the distress button after the countdown is complete		
3	Verify that EUT receives the alert	Yes	No
4	Cause QE1 to cancel the alert		
5	Verify that EUT provides both a visual and aural alarm cancellation component	Yes	No
6	Cancel the alarm manually		
7	Verify that EUT stops visual and aural alarm component	Yes	No
Final verdict:			

6.9.2 Alarms when busy

Interoperability Test Description			
Identifier:	TD_DSC_VHF_IOF_0024		
Summary:	Visual and aural alarm for Distress alert when EUT busy - initiator		
Configuration:	CF_2		
References:	ETSI EN 300 338-5 [1], clause 6.9.2.1		
Pre-test conditions:			
Step	Test Sequence	Verdict	
		Pass	Fail
1	On EUT select 'Call' then select 'Individual - Routine'		
2	Enter/select MMSI of QE1		
3	Accept the proposed channel		
4	Cause EUT to send the individual call to QE1		
5	Verify that QE1 receives the call	Yes	No
6	On QE1 push Distress Button		
7	Release the distress button after the countdown is complete		
8	Verify that EUT sounds the discrete audible alarm and displays distress information	Yes	No
9	Do not accept the distress call		
10	Verify that EUT logs the distress call	Yes	No
Final verdict:			

Interoperability Test Description			
Identifier:	TD_DSC_VHF_IOF_0025		
Summary:	Visual and aural alarm for Distress alert when EUT busy - receiver		
Configuration:	CF_2		
References:	ETSI EN 300 338-5 [1], clause 6.9.2.1		
Pre-test conditions:			
Step	Test Sequence	Verdict	
		Pass	Fail
1	On QE1 select 'Call' then select 'Individual - Routine'		
2	Enter/select MMSI of EUT		
3	Accept the proposed channel		
4	Cause QE1 to send the individual call to EUT		
5	Verify that EUT receives the call	Yes	No
6	On QE1 push Distress Button		
7	Release the distress button after the countdown is complete		
8	Verify that EUT sounds the discrete audible alarm and displays distress information	Yes	No
9	Do not accept the distress call		
10	Verify that EUT logs the distress call	Yes	No
Final verdict:			

Interoperability Test Description			
Identifier:	TD_DSC_VHF_IOF_0026		
Summary:	Logging and Aural alarm for lower priority call when EUT busy - initiator		
Configuration:	CF_5		
References:	ETSI EN 300 338-5 [1], clause 6.9.2.1		
Pre-test conditions:			
Step	Test Sequence	Verdict	
		Pass	Fail
1	On EUT push Distress Button		
2	Release the distress button after the countdown is complete		
3	Verify that QE1 receives the alert	Yes	No
4	Do not cause QE1 to acknowledge the alert		
5	On QE2 select 'Call' then select 'Individual - Routine'		
6	Enter/select MMSI of EUT		
7	Accept the proposed channel		
8	Cause QE2 to send the individual call to EUT		
9	Verify that EUT sounds the discrete audible alarm	Yes	No
10	Verify that EUT logs the call amongst unread calls	Yes	No
Final verdict:			

Interoperability Test Description			
Identifier:	TD_DSC_VHF_IOF-0027		
Summary:	Logging and Aural alarm for lower priority call when EUT busy - receiver		
Configuration:	CF_5		
References:	ETSI EN 300 338-5 [1], clause 6.9.2.1		
Pre-test conditions:			
Step	Test Sequence	Verdict	
		Pass	Fail
1	On QE1 push Distress Button		
2	Release the distress button after the countdown is complete		
3	Verify that EUT receives the alert	Yes	No
4	On QE2 select 'Call' then select 'Individual - Routine'		
5	Enter/select MMSI of EUT		
6	Accept the proposed channel		
7	Cause QE2 to send the individual call to EUT		
8	Verify that EUT sounds the discrete audible alarm	Yes	No
9	Verify that EUT logs the call amongst unread calls	Yes	No
Final verdict:			

6.9.3 Standby mode interface functions

Interoperability Test Description			
Identifier:	TD_DSC_VHF_IOF_0028		
Summary:	Availability of Distress button during standby mode		
Configuration:	CF_1		
References:	ETSI EN 300 338-5 [1], clause 6.3		
Pre-test conditions:			
Step	Test Sequence	Verdict	
		Pass	Fail
1	Verify that EUT has a dedicated distress button available either as a dedicated and labelled 'Distress' button or as a top-level soft-button on a touchscreen	Yes	No
Final verdict:			

Interoperability Test Description			
Identifier:	TD_DSC_VHF_IOF_0029		
Summary:	Availability of means to compose a non-distress DSC message during standby mode		
Configuration:	CF_1		
References:	ETSI EN 300 338-5 [1], clause 6.3		
Pre-test conditions:			
Step	Test Sequence	Verdict	
		Pass	Fail
1	Verify that EUT has clearly labelled means to compose/send a non-distress DSC message	Yes	No
Final verdict:			

Interoperability Test Description			
Identifier:	TD_DSC_VHF_IOF_0030		
Summary:	Availability of required functions via a maximum of two menu layers during standby mode		
Configuration:	CF_1		
References:	ETSI EN 300 338-5 [1], clause 6.3		
Pre-test conditions:			
Step	Test Sequence	Verdict	
		Pass	Fail
1	Verify that EUT's MMSI information can be accessed via a maximum of two menu layers from the top-level	Yes	No
2	Verify that EUT's latest position can be viewed via a maximum of two menu layers from the top-level	Yes	No
3	Verify that the UTC acquisition time of the EUT's latest position can be viewed via a maximum of two menu layers from the top-level	Yes	No
4	Verify that a clearly labelled means to compose a distress alert can be accessed in the EUT via a maximum of two menu layers from the top-level	Yes	No
Final verdict:			

Interoperability Test Description			
Identifier:	TD_DSC_VHF_IOF_0031		
Summary:	Availability of required configuration options and timers		
Configuration:	CF_1		
References:	ETSI EN 300 338-5 [1], clause 6.3		
Pre-test conditions:			
Step	Test Sequence	Verdict	
		Pass	Fail
1	Verify that EUT provides the option to auto acknowledge test DSC messages, being set to 'on' by default	Yes	No
2	Verify that the above option is being set to 'on' by default	Yes	No
3	Verify that EUT provides the option to auto acknowledge individually addressed, non-distress DSC messages	Yes	No
4	Verify that the above option is being set to 'off' by default	Yes	No
5	Verify that EUT provides the option to set the no activity timeout to exit any non-automated procedure activity to some value that includes no timeout	Yes	No
6	Verify that the above option is being set to '10 minutes' by default	Yes	No
7	Verify that EUT provides the option to set the no activity timeout of non-distress DSC automated procedures to some value that includes no timeout	Yes	No
8	Verify that the above option is being set to '15 minutes' by default	Yes	No
9	Verify that EUT provides the option to set the no activity timeout of received distress DSC automated procedures to some value that includes no timeout	Yes	No
10	Verify that the above option is being set to 'no timeout' by default	Yes	No
11	Verify that EUT does not provide any option to set any timeout of the unacknowledged sending distress automated procedure	Yes	No
12	Verify that EUT provides the option to set the no activity timeout of communications automated procedures to some value in the range [10 seconds to 10 minutes]	Yes	No
13	Verify that the above option is being set to '30 seconds' by default	Yes	No
Final verdict:			

Interoperability Test Description			
Identifier:	TD_DSC_VHF_IOF_0032		
Summary:	Availability of required DSC distress activity recording		
Configuration:	CF_1		
References:	ETSI EN 300 338-5 [1], clause 6.3		
Pre-test conditions:			
Step	Test Sequence	Verdict	
		Pass	Fail
1	On QE1 push Distress Button		
2	Release the distress button after the countdown is complete		
3	Execute this distress sending procedure twenty times, waiting at least 5 seconds between subsequent repetitions		
4	Verify that EUT provides the record of all twenty DSC distress messages, where each distress alert attempt is recorded as a single message	Yes	No
5	Verify that EUT provides the UTC time of reception date for each of the above message records	Yes	No
6	Verify that EUT provides the information content of the DSC message for each of the above message records	Yes	No
Final verdict:			

Interoperability Test Description			
Identifier:	TD_DSC_VHF_IOF_0033		
Summary:	Availability of required DSC non distress activity recording		
Configuration:	CF_1		
References:	ETSI EN 300 338-5 [1], clause 6.3		
Pre-test conditions:			
Step	Test Sequence	Verdict	
		Pass	Fail
1	On QE1 select 'Call' then select 'Individual - Routine'		
2	Enter/select MMSI of EUT		
3	Accept the proposed channel		
4	Cause QE1 to send the individual call to EUT		
5	Repeat the above steps 1 to 4 nineteen times, so that twenty calls have been made in total		
6	Verify that EUT provides the record of all twenty DSC non distress messages, where each call data is recorded as a single message	Yes	No
7	Verify that EUT provides the UTC time of reception date for each of the above message records	Yes	No
8	Verify that EUT provides the information content of the DSC message for each of the above message records	Yes	No
Final verdict:			

Annex A (informative): Bibliography

- ETSI ES 202 553: "Methods for testing and Specification (MTS); TPLan: A notation for expressing test Purposes".
- ETSI TS 102 351 (V2.1.1): "Methods for Testing and Specification (MTS); Internet Protocol Testing (IPT); IPv6 Testing: Methodology and Framework".
- ISO/IEC 9646-2: "Information technology - Open Systems Interconnection - Conformance testing methodology and framework - Part 2: Abstract Test Suite specification".

History

Document history		
V1.1.1	June 2012	Publication
V1.2.1	February 2020	Publication