

ETSI TS 101 376-7-1 V1.1.1 (2001-03)

Technical Specification

**GEO-Mobile Radio Interface Specifications;
Part 7: Terminal adaptor specifications;
Sub-part 1: General on Terminal Adaptation Functions (TAF)
for Mobile Earth Stations (MES);
GMR-1 07.001**



Reference

DTS/SES-001-07001

Keywords

adaption, MES, interface, mobile, radio, terminal

ETSI

650 Route des Lucioles
F-06921 Sophia Antipolis Cedex - FRANCE

Tel.: +33 4 92 94 42 00 Fax: +33 4 93 65 47 16

Siret N° 348 623 562 00017 - NAF 742 C
Association à but non lucratif enregistrée à la
Sous-Préfecture de Grasse (06) N° 7803/88

Important notice

Individual copies of the present document can be downloaded from:

<http://www.etsi.org>

The present document may be made available in more than one electronic version or in print. In any case of existing or perceived difference in contents between such versions, the reference version is the Portable Document Format (PDF). In case of dispute, the reference shall be the printing on ETSI printers of the PDF version kept on a specific network drive within ETSI Secretariat.

Users of the present document should be aware that the document may be subject to revision or change of status. Information on the current status of this and other ETSI documents is available at <http://www.etsi.org/tb/status/>

If you find errors in the present document, send your comment to:
editor@etsi.fr

Copyright Notification

No part may be reproduced except as authorized by written permission.
The copyright and the foregoing restriction extend to reproduction in all media.

© European Telecommunications Standards Institute 2001.
All rights reserved.

Contents

Intellectual Property Rights	5
Foreword.....	7
Introduction.....	8
1 Scope.....	9
2 References.....	9
3 Abbreviations	10
4 Access reference configuration	10
5 Functions to support data services.....	11
6 Support of nontransparent bearer services	11
6.1 Functions of the layer 2 relay.....	11
6.2 Radio link services used	11
6.3 Flow control - general description.....	11
6.3.1 End to end flow control.....	12
6.3.2 Back pressure.....	12
6.3.3 Receive not ready.....	12
7 Structure of the GMR-1 07-series of specifications	12
8 Functions common to all interfaces	12
8.1 Synchronization of the traffic channel.....	12
8.2 Filtering of channel control information.....	12
8.2.1 General.....	12
8.2.2 Filtering process to be applied.....	12
8.3 Terminal compatibility decision.....	12
8.3.1 Compatibility check.....	13
8.3.2 Selection of appropriate terminal function	13
8.3.3 Indication of compatibility requirements to the satellite system	13
8.3.3.1 Indication in case of mobile terminating calls.....	13
8.3.3.2 Indication in case of mobile originating calls.....	14
8.4 Test loops.....	15
8.5 Alternate speech/data and speech/facsimile group 3	15
Annex A (informative): List of bearer capability elements	16
Annex B (normative): Setting of bearer capability, low layer compatibility and high layer compatibility information element for GMR-1 bearer services and GMR-1 teleservices	17
B.0 Scope.....	17
B.1 Bearer capability information element.....	17
B.1.1 Introduction.....	17
B.1.1.1 General consideration.....	17
B.1.1.2 Interpretation of the diagrams.....	17
B.1.2 Bearer service 21... 26, data circuit duplex asynchronous	21
B.1.2.1 Unrestricted digital information transfer capability	21
B.1.2.2 3,1 kHz audio ex-PLMN information transfer capability	22
B.1.3 Bearer service 31... 34, data circuit duplex synchronous	22
B.1.3.1 Unrestricted digital information transfer capability	22
B.1.3.1.1 X.32 case (packet service).....	23
B.1.3.2 3,1 kHz audio ex-PLMN information transfer capability	23
B.1.3.2.1 Non-X.32 cases	23
B.1.3.2.2 X.32 case (packet service).....	23
B.1.4 Bearer service 41... 46, PAD access asynchronous	23

B.1.5	Bearer service 51... 53, data packet duplex synchronous, unrestricted digital information transfer capability	23
B.1.6	Bearer service 61, alternate speech/data	23
B.1.6.1	Bearer service 61, speech	24
B.1.6.2	Bearer service 61, 3,1 kHz audio ex-PLMN information transfer capability.....	25
B.1.6.2.1	Asynchronous.....	25
B.1.6.2.2	Synchronous.....	25
B.1.7	Bearer service 81, speech followed by data	26
B.1.7.1	Bearer service 81, speech	26
B.1.7.2	Bearer service 81, 3,1 kHz audio ex-PLMN information transfer capability.....	26
B.1.7.2.1	Asynchronous.....	26
B.1.7.2.2	Synchronous.....	26
B.1.8	Teleservice 11... 12, speech	26
B.1.9	Teleservice 21... 23, short message	26
B.1.10	Teleservice 61, alternate speech and facsimile group 3.....	26
B.1.10.1	Teleservice 61, speech.....	26
B.1.10.2	Teleservice 61, facsimile group 3	27
B.1.11	Teleservice 62, automatic facsimile group 3.....	27
B.2	Low layer/high layer compatibility information element	27
B.2.1	Introduction.....	27
B.2.1.1	General consideration.....	27
B.2.1.2	Interpretation of the tables.....	28
B.2.2	LLC bearer service 21... 26.....	28
B.2.2.1	Unrestricted digital information transfer capability	28
B.2.2.2	3,1 kHz audio ex-PLMN information transfer capability	28
B.2.3	LLC bearer service 31... 34.....	28
B.2.3.1	Unrestricted digital information transfer capability	28
B.2.3.2	3,1 kHz audio ex-PLMN information transfer capability	28
B.2.4	LLC bearer service 41... 46.....	28
B.2.5	LLC bearer services 51... 53	28
B.2.5.1	Unrestricted digital information transfer capability	28
B.2.6	LLC bearer service 61	28
B.2.6.1	3,1 kHz audio ex-PLMN information transfer capability, asynchronous	28
B.2.6.2	3,1 kHz audio ex-PLMN information transfer capability, synchronous	28
B.2.7	LLC bearer service 81	29
B.2.7.1	3,1 kHz audio ex-PLMN information transfer capability, asynchronous	29
B.2.7.2	3,1 kHz audio ex-PLMN information transfer capability, synchronous	29
B.2.8	HLC teleservices 11... 12.....	29
B.2.9	HLC teleservices 21... 23.....	29
B.2.10	HLC teleservice 61	29
B.2.11	HLC teleservice 62.....	29
History	30

Intellectual Property Rights

The information pertaining to essential IPRs is publicly available for **ETSI members and non-members**, and can be found in ETSI SR 000 314: "*Intellectual Property Rights (IPRs); Essential, or potentially Essential, IPRs notified to ETSI in respect of ETSI standards*", which is available from the ETSI Secretariat. Latest updates are available on the ETSI Web server (<http://www.etsi.org/ipr>).

The attention of ETSI has been drawn to the Intellectual Property Rights (IPRs) listed below which are, or may be, or may become, Essential to the present document. The IPR owner has undertaken to grant irrevocable licences, on fair, reasonable and non-discriminatory terms and conditions under these IPRs pursuant to the ETSI IPR Policy. Further details pertaining to these IPRs can be obtained directly from the IPR owner.

The present IPR information has been submitted to ETSI and pursuant to the ETSI IPR Policy, no investigation, including IPR searches, has been carried out by ETSI. No guarantee can be given as to the existence of other IPRs not referenced in ETSI SR 000 314 (or the updates on the ETSI Web server) which are, or may be, or may become, essential to the present document.

IPRs:

Project	Company	Title	Country of Origin	Patent n°	Countries Applicable
TS 101 376 V1.1.1	Digital Voice Systems Inc		US	US 5,226,084	US
TS 101 376 V1.1.1	Digital Voice Systems Inc		US	US 5,715,365	US
TS 101 376 V1.1.1	Digital Voice Systems Inc		US	US 5,826,222	US
TS 101 376 V1.1.1	Digital Voice Systems Inc		US	US 5,754,974	US
TS 101 376 V1.1.1	Digital Voice Systems Inc		US	US 5,701,390	US

IPR Owner: Digital Voice Systems Inc
One Van de Graaff Drive Burlington,
MA 01803
USA

Contact: John C. Hardwick
Tel.: +1 781-270-1030
Fax: +1 781-270-0166

Project	Company	Title	Country of Origin	Patent n°	Countries Applicable
TS 101 376 V1.1.1	Ericsson Mobile Communication	Improvements in, or in relation to, equalisers	GB	GB 2 215 567	GB
TS 101 376 V1.1.1	Ericsson Mobile Communication	Power Booster	GB	GB 2 251 768	GB
TS 101 376 V1.1.1	Ericsson Mobile Communication	Receiver Gain	GB	GB 2 233 846	GB
TS 101 376 V1.1.1	Ericsson Mobile Communication	Transmitter Power Control for Radio Telephone System	GB	GB 2 233 517	GB

IPR Owner: Ericsson Mobile Communications (UK) Limited
The Keytech Centre, Ashwood Way
Basingstoke
Hampshire RG23 8BG
United Kingdom

Contact: John Watson
Tel.: +44 1256 864821

Project	Company	Title	Country of Origin	Patent n°	Countries Applicable
TS 101 376 V1.1.1	Hughes Network Systems		US	Pending	US

IPR Owner: Hughes Network Systems
11717 Exploration Lane
Germantown, Maryland 20876
USA

Contact: John T. Whelan
Tel: +1 301-428-7172
Fax: +1 301-428-2802

Project	Company	Title	Country of Origin	Patent n°	Countries Applicable
TS 101 376 V1.1.1	Lockheed Martin Global Telecommunic. Inc	2.4-to-3 KBPS Rate Adaptation Apparatus for Use in Narrowband Data and Facsimile Communication Systems	US	US 6,108,348	US
TS 101 376 V1.1.1	Lockheed Martin Global Telecommunic. Inc	Cellular Spacecraft TDMA Communications System with Call Interrupt Coding System for Maximizing Traffic Throughput	US	US 5,717,686	US
TS 101 376 V1.1.1	Lockheed Martin Global Telecommunic. Inc	Enhanced Access Burst for Random Access Channels in TDMA Mobile Satellite System	US	US 5,875,182	
TS 101 376 V1.1.1	Lockheed Martin Global Telecommunic. Inc	Spacecraft Cellular Communication System	US	US 5,974,314	US
TS 101 376 V1.1.1	Lockheed Martin Global Telecommunic. Inc	Spacecraft Cellular Communication System	US	US 5,974,315	US
TS 101 376 V1.1.1	Lockheed Martin Global Telecommunic. Inc	Spacecraft Cellular Communication System with Mutual Offset High-argin Forward Control Signals	US	US 6,072,985	US
TS 101 376 V1.1.1	Lockheed Martin Global Telecommunic. Inc	Spacecraft Cellular Communication System with Spot Beam Pairing for Reduced Updates	US	US 6,118,998	US

IPR Owner: Lockheed Martin Global Telecommunications, Inc.
900 Forge Road
Norrstown, PA. 19403
USA

Contact: R.F. Franciose
Tel.: +1 610.354.2535
Fax: +1 610.354.7244

Foreword

This Technical Specification (TS) has been produced by ETSI Technical Committee Satellite Earth Stations and Systems (SES).

The contents of the present document are subject to continuing work within TC-SES and may change following formal TC-SES approval. Should TC-SES modify the contents of the present document it will then be republished by ETSI with an identifying change of release date and an increase in version number as follows:

Version 1.m.n

where:

- the third digit (n) is incremented when editorial only changes have been incorporated in the specification;
- the second digit (m) is incremented for all other types of changes, i.e. technical enhancements, corrections, updates, etc.

The present document is part 7, sub-part 1 of a multi-part deliverable covering the GEO-Mobile Radio Interface Specifications, as identified below:

Part 1: "General specifications";

Part 2: "Service specifications";

Part 3: "Network specifications";

Part 4: "Radio interface protocol specifications";

Part 5: "Radio interface physical layer specifications";

Part 6: "Speech coding specifications";

Part 7: "Terminal adaptor specifications";

Sub-part 1: "General on Terminal Adaptation Functions (TAF) for Mobile Earth Stations (MES); GMR-1 07.001";

Sub-part 2: "Terminal Adaptation Functions (TAF) for Services Using Asynchronous Bearer capabilities; GMR-1 07.002";

Sub-part 3: "Terminal Adaptation Functions (TAF) for Services Using Synchronous Bearer Capacities; GMR-1 07.003".

Introduction

GMR stands for GEO (Geostationary Earth Orbit) Mobile Radio interface, which is used for mobile satellite services (MSS) utilizing geostationary satellite(s). GMR is derived from the terrestrial digital cellular standard GSM and supports access to GSM core networks.

Due to the differences between terrestrial and satellite channels, some modifications to the GSM standard are necessary. Some GSM specifications are directly applicable, whereas others are applicable with modifications. Similarly, some GSM specifications do not apply, while some GMR specifications have no corresponding GSM specification.

Since GMR is derived from GSM, the organization of the GMR specifications closely follows that of GSM. The GMR numbers have been designed to correspond to the GSM numbering system. All GMR specifications are allocated a unique GMR number as follows:

GMR-n xx.zyy

where:

xx.0yy (z=0) is used for GMR specifications that have a corresponding GSM specification. In this case, the numbers xx and yy correspond to the GSM numbering scheme.

xx.2yy (z=2) is used for GMR specifications that do not correspond to a GSM specification. In this case, only the number xx corresponds to the GSM numbering scheme and the number yy is allocated by GMR.

n denotes the first (n=1) or second (n=2) family of GMR specifications.

A GMR system is defined by the combination of a family of GMR specifications and GSM specifications as follows:

- If a GMR specification exists it takes precedence over the corresponding GSM specification (if any). This precedence rule applies to any references in the corresponding GSM specifications.

NOTE: Any references to GSM specifications within the GMR specifications are not subject to this precedence rule. For example, a GMR specification may contain specific references to the corresponding GSM specification.

- If a GMR specification does not exist, the corresponding GSM specification may or may not apply. The applicability of the GSM specifications is defined in GMR-1 01 [9].201 [9].

1 Scope

The present document is based on the principles of terminal adapter functions presented in the ITU-T I-series of recommendations (I.460-I.463 [8]).

The GMR-1 satellite system supports a wide range of voice and non-voice services in the same network. In order to enable non-voice traffic in the GMR-1 satellite system there is a need to connect various kinds of terminal equipment to the Mobile Termination (MT). The target of the present document is to outline the functions needed for the terminal adaptation.

In GSM 02.02 [2] the bearer services are described. The general network configuration is described in GMR-1 03.002 [3] and the GMR-1 satellite network access reference configuration is defined in GMR-1 04.002 [5]. The various connection types used in the GMR-1 satellite network are presented in GSM 03.10 [4]. Terminology used in the present document is presented in GMR-1 01.004 [1]. For support of data services between GMR-1 satellite network and other networks see GSM 09-series of Specifications.

2 References

The following documents contain provisions which, through reference in this text, constitute provisions of the present document.

- References are either specific (identified by date of publication, edition number, version number, etc.) or non-specific.
- For a specific reference, subsequent revisions do not apply.
- For a non-specific reference, subsequent revisions do apply.

- [1] GMR-1 01.004 (ETSI TS 101 376-1-1): "GEO-Mobile Radio Interface Specifications; Part 1: General specifications; Sub-part 1: Abbreviations and acronyms; GMR-1 01.004".
- [2] GSM 02.02 (ETSI ETS 300 501): "European digital cellular telecommunications system (Phase 2); Bearer Services (BS) supported by a GSM Public Land Mobile Network (PLMN) (GSM 02.02 version 4.2.2)".
- [3] GMR-1 03.002 (ETSI TS 101 376-3-10): "GEO-Mobile Radio Interface Specifications; Part 3: Network specifications; Sub-part 10: Functions related to Mobile Earth Station (MES) in idle mode; GMR-1 03.002".
- [4] GSM 03.10 (ETSI ETS 300 528): "European digital cellular telecommunications system (Phase 2); GSM Public Land Mobile Network (PLMN) connection types (GSM 03.10 version 4.3.1)".
- [5] GMR-1 04.002 (ETSI TS 101 376-4-2): "GEO-Mobile Radio Interface Specifications; Part 4: Radio interface protocol specifications; Sub-part 2: GMR-1 Satellite Network Access Reference Configuration; GMR-1 04.002".
- [6] GMR-1 04.008 (ETSI TS 101 376-4-8): "GEO-Mobile Radio Interface Specifications; Part 4: Radio interface protocol specifications; Sub-part 8: Mobile Radio Interface Layer 3 Specifications; GMR -1 04.008".
- [7] GMR-1 04.021 (ETSI TS 101 376-4-10): "GEO-Mobile Radio Interface Specifications; Part 4: Radio interface protocol specifications; Sub-part 10: Rate Adaptation on the Access Terminal-Gateway Station Subsystem (MES-GSS) Interface; GMR-1 04.021".
- [8] ITU-T Recommendation I.460-I.464: "Multiplexing, rate adaption and support of existing interfaces".
- [9] GMR-1 01.201 (ETSI TS 101 376-1-2): "GEO-Mobile Radio Interface Specifications; Part 1: General specifications; Sub-part 2: Introduction to the GMR-1 Family; GMR-1 01.201".

- [10] GSM 07.01 (ETSI ETS 300 913): "Digital cellular telecommunications system (Phase 2+); General on Terminal Adaptation Functions (TAF) for Mobile Stations (MS) (GSM 07.01 version 5.9.1)".
- [11] ITU-T Recommendation V.25bis: "Synchronous and asynchronous automatic dialling procedures on switched networks".
- [12] ITU-T Recommendation V.25ter: "Serial asynchronous automatic dialling and control".

3 Abbreviations

For the purposes of the present document, the following abbreviations apply:

CALL PROC: CALL PROCEEDING
CALL CONF: CALL CONFIRMED
CONNACK: CONNECT ACKNOWLEDGEMENT
NAV: Not available

Other abbreviations used in the present document are listed in GMR-1 01.004 [1].

4 Access reference configuration

Figure 1 presents the reference configuration for access to a GMR-1 satellite system (see GMR-1 04.002 [5]).

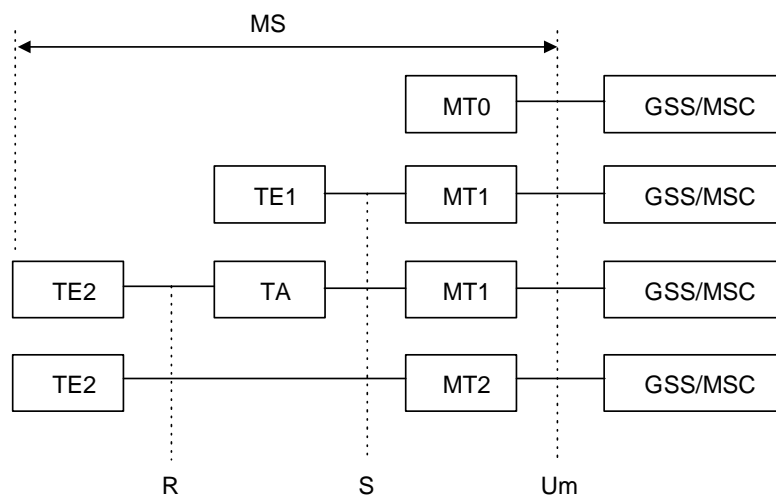

⊥ = REFERENCE POINT
 TE1 = ISDN TERMINAL
 TE2 = V- OR X-TYPE TERMINAL
 TA = TERMINAL ADAPTER
 GSS = GATEWAY STATION SYSTEM
 MSC = MOBILE SWITCHING CENTER

G-13944 V 10/09/98

Figure 1: GMR-1 Satellite System Access Reference Configuration

The preferred configuration for GMR-1 satellite system is MT2 where the mobile terminal has a built-in terminal adapter. Alternate configurations include Mobile Termination MT0 which is a fully integrated MES including data terminal and its adaptation functions. MT1 includes ISDN terminal adaptation functions.

5 Functions to support data services

The main functions of the MES to support data services are:

- Functions to ensure conformity of terminal service requests to network capability;
- Physical connection of the reference points R and S;
- Flow control of signalling and mapping of user signalling to/from GMR-1 satellite access signalling;
- Rate adaptation of user data (see GMR-1 04.021 [7]);
- Flow control of nontransparent user data and mapping of flow control for asynchronous data services;
- Support of data integrity between the MES and the interworking function in the GMR-1 satellite system;
- End-to-end synchronization between terminals;
- Filtering of status information;
- Functions to support nontransparent bearer services, e.g., termination of the Radio Link Protocol (RLP) and the Layer 2 Relay function (L2R) (where applicable);
- Terminal compatibility checking;
- Optional support of local test loops.

In addition, functions to support autocalling and autoanswering are optionally specified in accordance with ITU-T Recommendation V.25bis [11] or V.25ter [12] (although the use of other autocalling/autoanswering procedures is not prohibited provided that mapping in a functionally equivalent way to GMR-1 04.008 [6] call control is also provided).

Other functional entities can be envisaged apart from the TAF. One of the physical interface to all these functions is the DTE/DCE interface to the MES. Normally, this DTE/DCE interface is associated with the TAF, if available. Therefore, the access to any of these other functional entities, if implemented, via the DCE/DTE interface must be triggered by appropriate command sequences which are described in the applicable specifications (although the use of other procedures is not prohibited provided that mapping in a functionally equivalent way is also provided). These command sequences can be issued by the DTE only when the MES is in the appropriate command status and there is no data connection pending. They are interpreted by an MES internal control function and result in an association of the DTE/DCE interface with the addressed function, if available.

6 Support of nontransparent bearer services

Same as clause 6 of GSM 07.01 [10].

6.1 Functions of the layer 2 relay

Same as clause 6.1 of GSM 07.01 [10].

6.2 Radio link services used

Same as clause 6.2 of GSM 07.01 [10].

6.3 Flow control - general description

Same as clause 6.3 of GSM 07.01 [10].

6.3.1 End to end flow control

Same as clause 6.3.1 of GSM 07.01 [10].

6.3.2 Back pressure

Same as clause 6.3.2 of GSM 07.01 [10].

6.3.3 Receive not ready

Same as clause 6.3.3 of GSM 07.01 [10].

7 Structure of the GMR-1 07-series of specifications

The structure of the Specifications is as follows:

GMR-1 07.001 General on Terminal Adaptation Functions for Mobile Earth Stations

GMR-1 07.002 Terminal Adaptation Functions for Services using Asynchronous Bearer Capabilities

The document defines the interfaces and terminal adaptation functions integral to a MT which enable the attachment of Asynchronous Terminals to a MT.

GMR-1 07.003 Terminal Adaptation Functions for Services using Synchronous Bearer Capabilities

The document defines the interfaces and terminal adaptation functions integral to a MT which enable the attachment of Synchronous Terminals to a MT.

8 Functions common to all interfaces

Same as clause 8 of GSM 07.01 [10].

8.1 Synchronization of the traffic channel

Same as clause 8.1 of GSM 07.01 [10].

8.2 Filtering of channel control information

Same as clause 8.2 of GSM 07.01 [10].

8.2.1 General

Same as clause 8.2.1 of GSM 07.01 [10].

8.2.2 Filtering process to be applied

Same as clause 8.2.2 of GSM 07.01 [10].

8.3 Terminal compatibility decision

Same as clause 8.3 of GSM 07.01 [10].

8.3.1 Compatibility check

Same as clause 8.3.1 of GSM 07.01 [10].

8.3.2 Selection of appropriate terminal function

Same as clause 8.3.2 of GSM 07.01 [10].

8.3.3 Indication of compatibility requirements to the satellite system

8.3.3.1 Indication in case of mobile terminating calls

In support of

- PSTN originated calls; and
- ISDN originated calls using 3,1 kHz audio Bearer Capability (BC); as well as
- ISDN originated calls using unrestricted digital Bearer Capability but not specifying all parameters for deducing a Bearer Service.

Mobile specific requirements to be dealt with in the Bearer Capability information element the call confirmed message has been introduced in the call control protocol (GMR-1 04.008 [6]). This also allows for renegotiations of specific parameters at the beginning of the connection set-up process. The specific parameters are:

a) Mobile specific requirements:

- Radio channel requirement,
- Connection element (transparent/nontransparent),
- Structure (note 1),
- User information layer 2 protocol (note 1),
- Intermediate rate (note 2), (note 3),
- Modem Type (note 1), (note 3),
- User Rate (note 3).

NOTE 1: This parameter is correlated with the value of the parameter connection element.

NOTE 2: For nontransparent services this parameter is correlated with the value of the parameter negotiation of intermediate rate requested.

NOTE 3: Modification of these parameters may be proposed by the MES. The network may accept it or not.

b) Requirements with effects at the partner terminal:

- Number of data bits,
- Number of stop bits,
- Parity.

The MES indicates the radio channel requirement in the call confirmed message. If the MES indicates the support of "dual" (HR and FR channels), the final decision as to which radio channel is chosen is done by the network in an RR message.

If the network proposes optional support of both transparent and nontransparent connection elements but does not indicate a user information layer 2 protocol, the MES shall set the appropriate value, if choosing nontransparent in the call confirmed message and out-band flow control is not requested.

Additionally the values of the parameters for structure, modem type, and intermediate rate have to be set in conformance with the values of the parameters radio channel requirements, negotiation of intermediate rate requested and connection element.

clause B.1.1.2 and table B.1 in the annex B describe the negotiation procedure. annex B, table B.4a describes the selection of the modem type and the dependence on the value of the parameter connection element. Annex B, table B.4b describes the selection of the intermediate rate and user rate and their dependence upon the value of the NIRR parameter and the equipment capabilities.

The following MTC cases can be deduced from the individual call set-up request conditions:

- a) If the set-up does not contain a BC information element, the MES in the call confirmed message shall include any BC information (single or multiple BC-IE). In case of multiple BC-IEs one BC-IE must indicate the information transfer capability "speech".
- b) If the set-up message contains a single BC-IE, the MES in the call confirm message shall use either a single BC-IE, if it wants to negotiate mobile specific parameter values, or, unless otherwise specified in annex B, no BC-IE, if it agrees with the requested ones.
- c) If the set-up contains a multiple BC-IE, the MES in the call confirmed message shall use either a multiple BC-IE, if it wants to negotiate mobile specific parameter values, or, unless otherwise specified in annex B, no BC-IE, if it agrees with the requested ones. Alternatively a single BC-IE containing fax Group 3 only shall be used if a multiple BC-IE requesting speech alternate fax Group 3 is received, and the MES is not able to support the speech capability. Annex B, table B.7, describes the negotiation rules.

If the BC-IE contains 3,1 kHz ex satellite system, the MES is allowed to negotiate all mobile specific parameter values listed above. If the BC-IE contains facsimile Group 3, the MES is allowed to negotiate the connection element (transparent/nontransparent) only. In any case, if the set-up message requests a "single service," the MES must not answer in the call confirmed message requesting a "dual service" and vice versa.

However, for dual services with repeat indicator set to circular (alternate) the MES may change the sequence of dual BC-IEs within the call confirmed message (preceded by the same value of the repeat indicator), if it wants to start with a different Bearer Capability than proposed by the network as the initial one.

The MES shall always return NIRR = 6 kbps in CALL CONFIRMED for those NT data calls with user rates less than or equal to 4.8 kbps message in response to a SETUP message from MSC, which also has a NIRR = 6 kbps (see table B.4b). In addition, the MES may propose to the network to modify User Rate, Modem Type, and Intermediate Rate in the CALL CONFIRMED message. The network may accept or release the call.

8.3.3.2 Indication in case of mobile originating calls

In support of mobile originating calls the values of BC-IE parameters are requested in the set-up message from the MES. If the MES indicates the support of both transparent and nontransparent connection elements the network shall return its choice in the call proceeding message. The MES is not allowed to indicate support of both transparent and nontransparent, if the MES also requests out-band flow control, i.e., it does not indicate a layer 2 protocol.

Additionally the value of the parameter modem type has to be set depending on the value of the parameter connection element as described in annex B, table B.4a.

The set-up message contains a single or multiple BC-IE. In case of multiple BC-IEs one BC-IE must indicate the information transfer capability "speech".

If the set-up message requests a "single service", the network must not answer in the call proceeding message requesting a "dual service" and vice versa. Alternatively the network shall answer with a single BC-IE containing fax Group 3 if a multiple BC-IE requesting speech alternate fax Group 3 is received but the network doesn't allow the use of this alternate service. Annex B, table B.7, describes the negotiation rules. If the MES requests a "dual service" the network is not allowed to change the sequence of the service.

If the set-up message indicates that negotiation of intermediate rate is requested then the network shall always honor this request as described in annex B, table B.4b.

Unless otherwise specified in annex B, if no BC-IE parameter needs negotiation it is up to the network if it sends a CALL PROC message (with or without a BC-IE) towards the MES or not.

8.4 Test loops

Same as clause 8.4 of GSM 07.01 [10].

8.5 Alternate speech/data and speech/facsimile group 3

Same as clause 8.5 of GSM 07.01 [10].

Annex A (informative): List of bearer capability elements

Same as annex A of GSM 07.01 [10].

Annex B (normative): Setting of bearer capability, low layer compatibility and high layer compatibility information element for GMR-1 bearer services and GMR-1 teleservices

B.0 Scope

Same as clause B.0 of GSM 07.01 [10].

B.1 Bearer capability information element

B.1.1 Introduction

B.1.1.1 General consideration

Same as clause B.1.1.1 of GSM 07.01 [10].

B.1.1.2 Interpretation of the diagrams

Same as clause B.1.1.2 of GSM 07.01 [10].

Tables B.1 to B.4a: same as tables B.1 to B.4a of GSM 07.01 [10].

If the user rate is 9.6 kbps the intermediate rate negotiation procedure is not applicable and NIRR shall be set to "No meaning".

Recipient of SETUP shall support full rate, nontransparent, 6 kbps radio interface rate for user rates up to/equal 4,8 kbps:

BC-parameter	Message SETUP	Message CALL CONF or CALL PROC
NIRR	6 kbit/s	6 kbit/s
IR	16 kbit/s	8 kbit/s
User Rate	up to/equal 4.8 kbit/s	as requested

Table B.4b: Intermediate rate negotiation procedure

NOTE: In case of a Mobile Terminated Call, if the SETUP message does not contain a BC-IE, the MES shall behave as if NIRR is set to "No meaning".

In case of a MOC or a MTC where no BC-IE is included in the CALL PROCEEDING or CALL CONFIRMED message, respectively, the MES or the network shall behave as if the NIRR was set to "No meaning".

Table B.5: BC parameter setting (part 1)

		-----+-----	
Abbreviations for Parameters and Values:		common setting of field values	-----+-----
		-----+-----	-----+-----
		default setting of field values (NA)	-----+-----
		v	v
ITC...Information Transfer Capability:	- Speech - UDI..Unrestricted Digital - FAX3..Group 3 Facsimile - 3.1 kHz..3.1 kHz Ex PLMN		
TM....Transfer Mode:	- ci..Circuit	X	X
S.....Structure:	- SDU..Service Data Unit Integrity - Unstructured	X	
C.....Configuration:	- pp..Point to point	X	X
E.....Establishment:	- de..Demand	X	X
SA....Sync/Async:	- S..Synchronous - A..Asynchronous		
N.....Negotiation	- ibn..in band negotiation not possible	X	X
UR....User Rate:	- 0.3..0.3 kbit/s - 1.2..1.2 kbit/s - 1.2/0.075..1200/75 bit/s - 2.4..2.4 kbit/s - 4.8..4.8 kbit/s - 9.6..9.6 kbit/s		
IR....Intermediate Rate:	- 4.. 4 kbit/s - 8.. 8 kbit/s - 16.. 16 kbit/s - not_used..not used	X	
NICT..Network Independent Clock on Tx:	- not_required.. Not required - required	X	X
NICR..Network Independent Clock on Rx:	- not_accepted..not accepted - accepted	X	X
NSB...Number of Stop Bits:	- 1..1 bit - 2..2 bit	X	
NDB...Number of Data Bits Excluding Parity If Present:	- 7.. 7 bit - 8.. 8 bit	X	
NPB...Parity Information:	- Odd - Even - None - 0.. Forced to 0 - 1.. Forced to 1	X	
UIL1P.User Information Layer 1 Protocol	- def..default layer 1 protocol	X	X

Table B.5: BC parameter setting (part 2)

Abbreviations for Parameters and Values		common setting of field values	default setting of field values (NA)
		-----+-----	-----+-----
			v
DM...Duplex Mode:	-		
	- fd.. Full Duplex		X
MT...Modem Type:	- V.21		
	- V.22		
	- V.22 bis		
	- V.23		
	- V.26 ter		
	- V.32		
	- autol.. autobauding type 1		
	- none		X
RCR...Radio Channel Requirement:	- FR Full Rate support only Mobile Station		X
	- dual HR Dual Rate support Mobile Station/ Half Rate preferred		
	- dual FR Dual Rate support Mobile Station/ Full Rate preferred		
CE...Connection Element:	- T.. Transparent		
	- NT.. Nontransparent		
	- bothT both transparent preferred		
	- bothNT both nontransparent preferred		
UIL2P>User Information Protocol:	2		
	- ISO6429..ISO6429, codeset 0, DC1/DC3		
	- X.25		
	- COPnoFlCt..Character oriented protocol with no flow control mechanism		
SAP...Signaling Access Protocol:	- I.440.. I.440/450		X
	- X.21		
	- X.28deIN.. X.28, dedicated PAD, individual NUI		
	- X.28deUN.. X.28, dedicated PAD, universal NUI		
	- X.28nond.. X.28, non dedicated PAD		
	- X.32		
RA...Rate Adaptation:	- V.110.. V.110/X.30		
	- X.31Flag.. X.31 flagstuffing		
	- NO.. no rate adaptation		X
CS...Coding Standard:	- GSM		X
NIRR..Negotiation of Intermediate Rate Requested:	NM..No Meaning associated with this value		X
	6kbit/s..6kbit/s radio interface rate requested		

Table B.6: channel combinations

Single Bearer and Teleservices

MES indication	Network selection CT
BC	CT
FR	FR

Alternate services

MES indication		Network selection	
BC(1)	BC(2)	CT(1)	CT(2)
FR	FR	FR	FR

BC Bearer Capability

CT Channel Type

Table B.7 is the same as table B.7 of GSM 07.01 [10].

B.1.2.2 3,1 kHz audio ex-PLMN information transfer capability

ITC	UDI	3.1 kHz	FAX3	speech						
+ Layer/protocol related :										
SAP	NA	I.440	X.28deIN	X.28deUN	X.28nond	X.32	X.21	res	3)	
RA	NA	V.110	X.31Flag	No						
SA		A		S			NA			
CE		NT	bothNT	bothT			T	NA		
S	NA	SDU								
UIL2P	X.25	ISO6429		COPnoFlCt			NAV		4)	
NDB	NA			7			8			
NPB	NA	odd	even	0	1		none			
NSB	NA			1			2			
+ Radio channel related :										
RCR				dualHR	dualFR		FR			
IR				8	16	not used	NA		2)	
UR	0.3	1.2	2.4	4.8	9.6	1.2/0.075 6)	NA		1)	
MT	none	V.21	V.22	V.22bis	V.26ter	V.32	V.23	auto1	1)	NA

for CE: NT or "both";
 for CE: T only or CE:NT and NIRR:6 kbps (not for the SETUP message);
 for MOC only;
 for MTC in the SETUP message or MOC/MTC with "out-band" flow control requested;
 for MOC/MTC with no flow control requested;
 MOC only, 75 bps in the uplink, 1200 bps in the downlink direction.

B.1.3 Bearer service 31... 34, data circuit duplex synchronous

B.1.3.1 Unrestricted digital information transfer capability

Not applicable.

B.1.3.1.1 X.32 case (packet service)

Not applicable.

B.1.3.2 3,1 kHz audio ex-PLMN information transfer capability**B.1.3.2.1 Non-X.32 cases**

Not applicable.

B.1.3.2.2 X.32 case (packet service)

Not applicable.

B.1.4 Bearer service 41... 46, PAD access asynchronous

Not applicable.

B.1.5 Bearer service 51... 53, data packet duplex synchronous, unrestricted digital information transfer capability

Not applicable.

B.1.6 Bearer service 61, alternate speech/data

The information element of the "repeat indicator" is set to the value "circular for successive selection (alternate)".

B.1.6.1 Bearer service 61, speech

ITC	UDI	3.1 kHz	FAX3	speech					
+--- Layer/protocol related: ---+									
SAP	NA	I.440	X.28deIN	X.28deUN	X.28nond	X.32	X.21	NAV	
RA	NA	V.110	X.31Flag	No				NAV	
SA		A		S			NA	NAV	
CE		NT	bothNT	bothT			T	NA	NAV
S	NA							NAV	
+-----+									
UIL2P	X.25	ISO6429		COPnoFlCt				NAV	
+-----+									
NDB	NA		7			8		NAV	
NPB	NA	odd	even	none	0	1		NAV	
NSB	NA		1			2		NAV	
+-----+									
+--- Radio channel related: ---+									
RCR			dualHR		dualFR		FR		
+-----+									
IR		8		16		not used	NA	NAV	
UR		0.3	1.2	2.4	4.8	9.6	1.2/0.075	NA	NAV
MT	none	V.21	V.22	V.22bis	V.26ter	V.32	V.23	auto1	NA NAV

B.1.6.2 Bearer service 61, 3,1 kHz audio ex-PLMN information transfer capability

B.1.6.2.1 Asynchronous

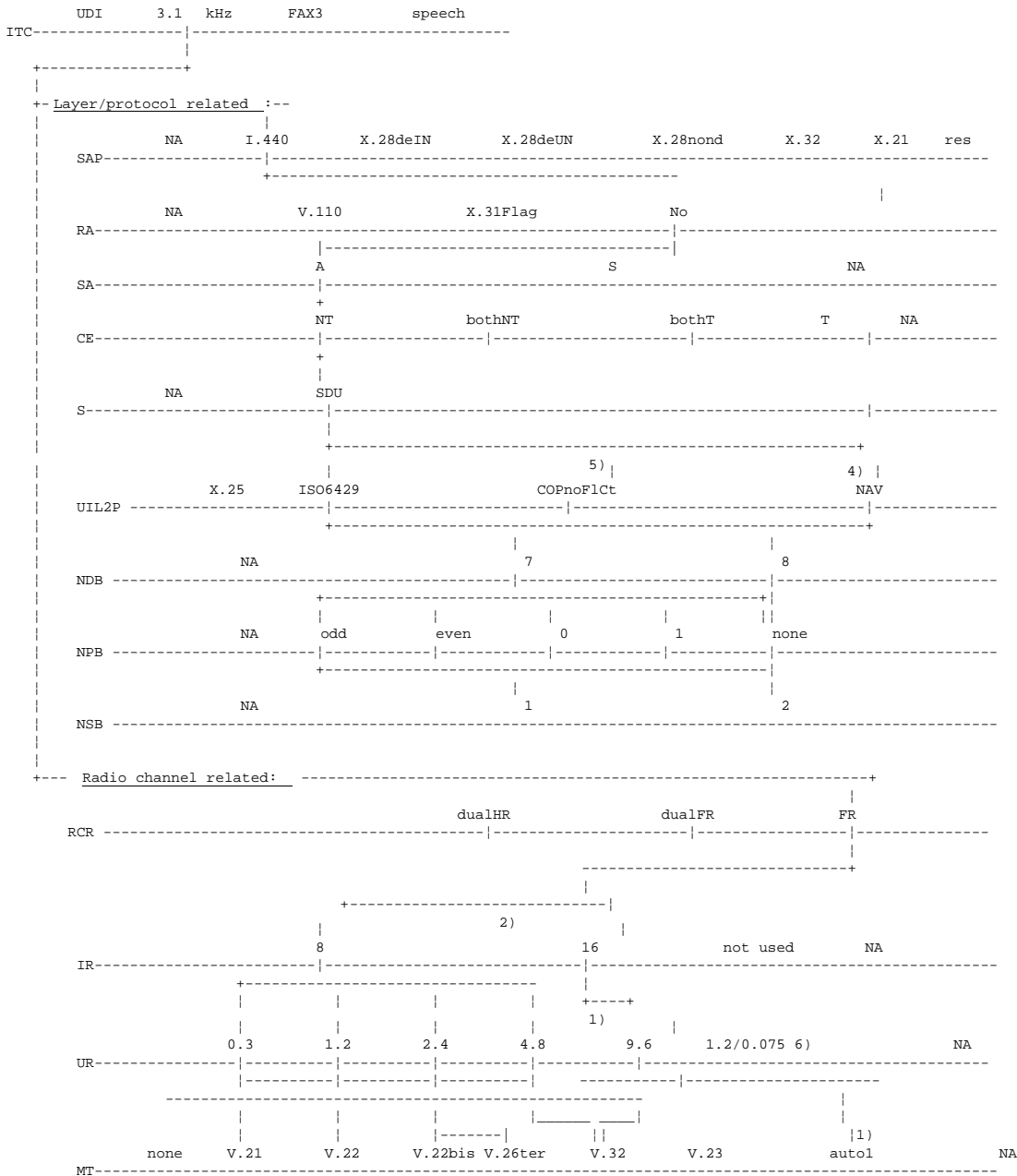

for CE: NT or "both";
 for CE: T only or CE:NT and NIRR: 6 kbps (not for the SETUP message);
 for MOC only;
 for MTC in the SETUP message or MOC/MTC with "out-band" flow control requested;
 for MOC/MTC with no flow control requested;
 MOC only, 75 bps in the uplink, 1200 bps in the downlink direction.

B.1.6.2.2 Synchronous

Not applicable.

B.1.7 Bearer service 81, speech followed by data

The information element of the "repeat indicator" is set to the value "sequential for successive selection (followed by)".

B.1.7.1 Bearer service 81, speech

Same as clause B.1.7.1 of GSM 07.01 [10].

B.1.7.2 Bearer service 81, 3,1 kHz audio ex-PLMN information transfer capability

B.1.7.2.1 Asynchronous

Same as clause B.1.7.2.1 of GSM 07.01 [10].

B.1.7.2.2 Synchronous

Same as clause B.1.7.2.2. of GSM 07.01 [10].

B.1.8 Teleservice 11... 12, speech

Same as clause B.1.8 of GSM 07.01 [10].

B.1.9 Teleservice 21... 23, short message

Not applicable.

B.1.10 Teleservice 61, alternate speech and facsimile group 3

The information element of the "repeat indicator" is set to the value "circular for successive selection (alternate)".

B.1.10.1 Teleservice 61, speech

Same as clause B.1.10.1 of GSM 07.01 [10].

B.1.10.2 Teleservice 61, facsimile group 3

ITC	UDI	3.1 kHz	FAX3	speech						
+-----+-----+-----+-----+-----+-----+-----+-----+-----+-----+-----+										
+Layer/protocol related:---+										
SAP	NA	I.440	X.28deIN	X.28deUN	X.28nond	X.32	X.21	res		
RA	NA	V.110	X.31Flag	No						
SA		A		S			NA			
CE		NT	bothNT	bothT			T	NA		
S	NA	SDU					unstructured			
UIL2P	X.25	ISO6429		COPnoFlCt			NAV			
NDB	NA		7				8			
NPB	NA	odd	even	0	1	none				
NSB	NA		1				2			
+-----+-----+-----+-----+-----+-----+-----+-----+-----+-----+-----+										
+Radio channel related:-----+										
RCR			dualHR	dualFR			FR			
IR		8		16	not_used		NA			
UR	0.3	1.2	2.4	4.8	9.6	1.2/0.075		NA		
MT	none	V.21	V.22	V.22bis	V.26ter	V.32	V.23	auto1	NA	

B.1.11 Teleservice 62, automatic facsimile group 3

Same as clause B.1.11 of GSM 07.01 [10], the information element "repeat indicator" is not available/valid.

B.2 Low layer/high layer compatibility information element

B.2.1 Introduction

B.2.1.1 General consideration

Same as clause B.2.1.1 of GSM 07.01 [10].

B.2.1.2 Interpretation of the tables

Same as clause B.2.1.2 of GSM 07.01 [10].

B.2.2 LLC bearer service 21... 26

B.2.2.1 Unrestricted digital information transfer capability

Same as clause B.2.2.1 of GSM 07.01 [10].

B.2.2.2 3,1 kHz audio ex-PLMN information transfer capability

Same as clause B.2.2.2 of GSM 07.01 [10].

B.2.3 LLC bearer service 31... 34

Same as clause B.2.3 of GSM 07.01 [10].

B.2.3.1 Unrestricted digital information transfer capability

Not applicable.

B.2.3.2 3,1 kHz audio ex-PLMN information transfer capability

Not applicable.

B.2.4 LLC bearer service 41... 46

Not applicable.

B.2.5 LLC bearer services 51... 53

B.2.5.1 Unrestricted digital information transfer capability

Not applicable.

B.2.6 LLC bearer service 61

Same as clause B.2.6 of GSM 07.01 [10].

B.2.6.1 3,1 kHz audio ex-PLMN information transfer capability, asynchronous

Same as clause B.2.6.1 of GSM 07.01 [10].

B.2.6.2 3,1 kHz audio ex-PLMN information transfer capability, synchronous

Same as clause B.2.6.2 of GSM 07.01 [10].

B.2.7 LLC bearer service 81

Same as clause B.2.7 of GSM 07.01 [10].

B.2.7.1 3,1 kHz audio ex-PLMN information transfer capability, asynchronous

Same as clause B.2.7.1 of GSM 07.01 [10].

B.2.7.2 3,1 kHz audio ex-PLMN information transfer capability, synchronous

Same as clause B.2.7.2 of GSM 07.01 [10].

B.2.8 HLC teleservices 11... 12

Same as clause B.2.8 of GSM 07.01 [10].

B.2.9 HLC teleservices 21... 23

Not applicable.

B.2.10 HLC teleservice 61

Same as clause B.2.10 of GSM 07.01 [10].

B.2.11 HLC teleservice 62

Same as clause B.2.11 of GSM 07.01 [10].

History

Document history		
V1.1.1	March 2001	Publication