

ETSI TS 101 376-5-7 V1.1.1 (2001-03)

Technical Specification

**GEO-Mobile Radio Interface Specifications;
Part 5: Radio interface physical layer specifications;
Sub-part 7: Radio Subsystem Synchronization;
GMR-1 05.010**



Reference

DTS/SES-001-05010

Keywords

GMR, MSS, MES, satellite, GSO, S-PCN, GSM,
interface, mobile, radio, synchronization, terminal,
user

ETSI

650 Route des Lucioles
F-06921 Sophia Antipolis Cedex - FRANCE

Tel.: +33 4 92 94 42 00 Fax: +33 4 93 65 47 16

Siret N° 348 623 562 00017 - NAF 742 C
Association à but non lucratif enregistrée à la
Sous-Préfecture de Grasse (06) N° 7803/88

Important notice

Individual copies of the present document can be downloaded from:
<http://www.etsi.org>

The present document may be made available in more than one electronic version or in print. In any case of existing or perceived difference in contents between such versions, the reference version is the Portable Document Format (PDF). In case of dispute, the reference shall be the printing on ETSI printers of the PDF version kept on a specific network drive within ETSI Secretariat.

Users of the present document should be aware that the document may be subject to revision or change of status. Information on the current status of this and other ETSI documents is available at <http://www.etsi.org/tb/status/>

If you find errors in the present document, send your comment to:
editor@etsi.fr

Copyright Notification

No part may be reproduced except as authorized by written permission.
The copyright and the foregoing restriction extend to reproduction in all media.

© European Telecommunications Standards Institute 2001.
All rights reserved.

Contents

Intellectual Property Rights	6
Foreword.....	8
Introduction.....	9
1 Scope.....	10
2 References.....	10
3 Definitions and abbreviations.....	10
3.1 Definitions	10
3.2 Abbreviations.....	11
4 General description of synchronization system.....	12
4.1 System timing structure.....	12
4.2 Timebase counter	12
4.3 General requirement.....	13
4.3.1 Timing and frequency reference point	13
4.3.2 MES requirement.....	13
4.3.3 Network requirement	13
4.3.4 Measurement conditions.....	13
5 Timing synchronization, TtG/GtT call.....	14
5.1 General description.....	14
5.2 Timing of forward link common channels.....	14
5.2.1 FCCH/BCCH timing.....	15
5.2.2 CCCH timing.....	15
5.3 Idle mode timing synchronization	15
5.3.1 Initial timing acquisition	15
5.3.2 Paging mode.....	15
5.3.3 Alerting mode.....	15
5.4 Synchronization at initial access	16
5.4.1 Synchronization process.....	16
5.4.2 RACH timing pre-correction	17
5.4.3 Description of parameters.....	18
5.4.4 Timing accuracy	19
5.5 Dedicated mode synchronization	19
5.5.1 In-call timing relationship	20
5.5.2 In-call synchronization scenario	20
5.5.3 Transmission timing drift rate.....	21
5.5.4 RX/TX guard time violation	22
5.6 Effect of the half symbol offset.....	22
6 Frequency synchronization, TtG/GtT call.....	23
6.1 General description.....	23
6.2 Frequency of common channels.....	23
6.3 Idle mode frequency synchronization.....	23
6.3.1 Initial frequency acquisition	23
6.3.2 Paging mode.....	23
6.3.3 Alerting mode.....	24
6.4 Synchronization at initial access	24
6.4.1 Frequency compensation strategy	24
6.4.2 Parameter description.....	25
6.5 Dedicated mode synchronization	26
7 Frame and message synchronization, TtG/GtT call.....	27
7.1 Frame synchronization	27
7.1.1 Frame number definition	27
7.1.2 Frame synchronization scenario.....	27

7.2	Message synchronization.....	28
7.2.1	Power control message synchronization.....	28
7.2.1.1	Synchronization in master-to-slave direction.....	29
7.2.1.2	Synchronization in slave-to-master direction.....	29
7.2.2	SACCH message synchronization, TCH6/TCH9 call.....	30
8	Synchronization for TtT call.....	30
8.1	Timing synchronization.....	31
8.1.1	General description.....	31
8.1.2	Initial access.....	31
8.1.2.1	Synchronization procedure.....	32
8.1.2.2	Basic requirement.....	32
8.1.3	TtG channel synchronization.....	33
8.1.3.1	Basic Requirement.....	33
8.1.4	Transition from TtG-to-TtT channel.....	33
8.1.4.1	Synchronization procedure.....	34
8.1.4.2	Basic requirement.....	34
8.1.5	TtT channel synchronization.....	34
8.1.5.1	Synchronization procedure.....	34
8.1.5.2	Basic requirement.....	35
8.1.6	Effect of the half symbol offset (TtT call).....	35
8.2	Frequency synchronization.....	35
8.2.1	General description.....	35
8.2.2	Synchronization at initial access.....	36
8.2.2.1	Synchronization procedure.....	36
8.2.2.2	Basic requirement.....	37
8.2.3	TtG channel synchronization.....	37
8.2.3.1	Basic requirement.....	37
8.2.4	Transition from TtG-to-TtT channel.....	37
8.2.4.1	Synchronization procedure.....	38
8.2.4.2	Basic requirement.....	38
8.2.5	TtT channel synchronization.....	38
8.2.5.1	Synchronization procedure.....	38
8.2.5.2	Basic requirement.....	39
8.3	Frame synchronization.....	39
9	Aeronautical terminal synchronization scheme.....	40
9.1	MES special features.....	40
9.1.1	Speed.....	40
9.1.2	Worst-case delay and doppler features.....	40
9.1.3	Frequency offset.....	40
9.2	Frequency synchronization.....	41
9.2.1	Frequency synchronization general description.....	41
9.2.2	Idle mode frequency synchronization.....	41
9.2.2.1	Initial frequency acquisition.....	41
9.2.2.2	Paging mode.....	41
9.2.2.3	Alerting mode.....	41
9.2.3	Synchronization at initial access.....	42
9.2.3.1	Frequency compensation strategy.....	42
9.2.3.2	Parameter description.....	42
9.2.4	Dedicated mode synchronization.....	42
9.2.4.1	Frequency compensation strategy.....	43
9.2.4.2	Parameter description.....	43
9.3	Timing synchronization.....	44
9.3.1	Timing synchronization general description.....	44
9.3.2	Idle mode timing synchronization.....	44
9.3.2.1	Initial timing acquisition.....	44
9.3.2.2	Paging mode.....	44
9.3.2.3	Alerting mode.....	44
9.3.3	Synchronization at initial access.....	45
9.3.4	Dedicated mode synchronization.....	45
9.3.4.1	Doppler-based timing adjustment.....	45

9.3.4.2	Standard timing synchronization procedure	45
9.3.4.3	Parameter description	45
Annex A (informative):	Worst-case delay and doppler features	46
Annex B (informative):	Range of timing correction factor	47
Annex C (informative):	Differential doppler frequency	48
Annex D (informative):	SACCH message synchronization, TtG/GtT call	49
D.1	SACCH message synchronization scenario	49
D.2	SACCH message-round trip delay	50
History	52

Intellectual Property Rights

The information pertaining to essential IPRs is publicly available for **ETSI members and non-members**, and can be found in ETSI SR 000 314: "*Intellectual Property Rights (IPRs); Essential, or potentially Essential, IPRs notified to ETSI in respect of ETSI standards*", which is available from the ETSI Secretariat. Latest updates are available on the ETSI Web server (<http://www.etsi.org/ipr>).

The attention of ETSI has been drawn to the Intellectual Property Rights (IPRs) listed below which are, or may be, or may become, Essential to the present document. The IPR owner has undertaken to grant irrevocable licences, on fair, reasonable and non-discriminatory terms and conditions under these IPRs pursuant to the ETSI IPR Policy. Further details pertaining to these IPRs can be obtained directly from the IPR owner.

The present IPR information has been submitted to ETSI and pursuant to the ETSI IPR Policy, no investigation, including IPR searches, has been carried out by ETSI. No guarantee can be given as to the existence of other IPRs not referenced in ETSI SR 000 314 (or the updates on the ETSI Web server) which are, or may be, or may become, essential to the present document.

IPRs:

Project	Company	Title	Country of Origin	Patent n°	Countries Applicable
TS 101 376 V1.1.1	Digital Voice Systems Inc		US	US 5,226,084	US
TS 101 376 V1.1.1	Digital Voice Systems Inc		US	US 5,715,365	US
TS 101 376 V1.1.1	Digital Voice Systems Inc		US	US 5,826,222	US
TS 101 376 V1.1.1	Digital Voice Systems Inc		US	US 5,754,974	US
TS 101 376 V1.1.1	Digital Voice Systems Inc		US	US 5,701,390	US

IPR Owner: Digital Voice Systems Inc
One Van de Graaff Drive Burlington,
MA 01803
USA

Contact: John C. Hardwick
Tel.: +1 781-270-1030
Fax: +1 781-270-0166

Project	Company	Title	Country of Origin	Patent n°	Countries Applicable
TS 101 376 V1.1.1	Ericsson Mobile Communication	Improvements in, or in relation to, equalisers	GB	GB 2 215 567	GB
TS 101 376 V1.1.1	Ericsson Mobile Communication	Power Booster	GB	GB 2 251 768	GB
TS 101 376 V1.1.1	Ericsson Mobile Communication	Receiver Gain	GB	GB 2 233 846	GB
TS 101 376 V1.1.1	Ericsson Mobile Communication	Transmitter Power Control for Radio Telephone System	GB	GB 2 233 517	GB

IPR Owner: Ericsson Mobile Communications (UK) Limited
The Keytech Centre, Ashwood Way
Basingstoke
Hampshire RG23 8BG
United Kingdom

Contact: John Watson
Tel.: +44 1256 864821

Project	Company	Title	Country of Origin	Patent n°	Countries Applicable
TS 101 376 V1.1.1	Hughes Network Systems		US	Pending	US

IPR Owner: Hughes Network Systems
11717 Exploration Lane
Germantown, Maryland 20876
USA

Contact: John T. Whelan
Tel: +1 301-428-7172
Fax: +1 301-428-2802

Project	Company	Title	Country of Origin	Patent n°	Countries Applicable
TS 101 376 V1.1.1	Lockheed Martin Global Telecommunic. Inc	2.4-to-3 Kbps Rate Adaptation Apparatus for Use in Narrowband Data and Facsimile Communication Systems	US	US 6,108,348	US
TS 101 376 V1.1.1	Lockheed Martin Global Telecommunic. Inc	Cellular Spacecraft TDMA Communications System with Call Interrupt Coding System for Maximizing Traffic Throughput	US	US 5,717,686	US
TS 101 376 V1.1.1	Lockheed Martin Global Telecommunic. Inc	Enhanced Access Burst for Random Access Channels in TDMA Mobile Satellite System	US	US 5,875,182	
TS 101 376 V1.1.1	Lockheed Martin Global Telecommunic. Inc	Spacecraft Cellular Communication System	US	US 5,974,314	US
TS 101 376 V1.1.1	Lockheed Martin Global Telecommunic. Inc	Spacecraft Cellular Communication System	US	US 5,974,315	US
TS 101 376 V1.1.1	Lockheed Martin Global Telecommunic. Inc	Spacecraft Cellular Communication System with Mutual Offset High-argin Forward Control Signals	US	US 6,072,985	US
TS 101 376 V1.1.1	Lockheed Martin Global Telecommunic. Inc	Spacecraft Cellular Communication System with Spot Beam Pairing for Reduced Updates	US	US 6,118,998	US

IPR Owner: Lockheed Martin Global Telecommunications, Inc.
900 Forge Road
Norrstown, PA. 19403
USA

Contact: R.F. Franciose
Tel.: +1 610.354.2535
Fax: +1 610.354.7244

Foreword

This Technical Specification (TS) has been produced by ETSI Technical Committee Satellite Earth Stations and Systems (SES).

The contents of the present document are subject to continuing work within TC-SES and may change following formal TC-SES approval. Should TC-SES modify the contents of the present document, it shall then be republished by ETSI with an identifying change of release date and an increase in version number as follows:

Version 1.m.n

where:

- the third digit (n) is incremented when editorial only changes have been incorporated in the specification;
- the second digit (m) is incremented for all other types of changes, i.e. technical enhancements, corrections, updates, etc.

The present document is part 5, sub-part 7 of a multi-part deliverable covering the GEO-Mobile Radio Interface Specifications, as identified below:

Part 1: "General specifications";

Part 2: "Service specifications";

Part 3: "Network specifications";

Part 4: "Radio interface protocol specifications";

Part 5: "Radio interface physical layer specifications";

Sub-part 1: "Physical Layer on the Radio Path: General Description; GMR-1 05.001";

Sub-part 2: "Multiplexing and Multiple Access; Stage 2 Service Description; GMR-1 05.002";

Sub-part 3: "Channel Coding; GMR-1 05.003";

Sub-part 4: "Modulation; GMR-1 05.004";

Sub-part 5: "Radio Transmission and Reception; GMR-1 05.005";

Sub-part 6: "Radio Subsystem Link Control; GMR-1 05.008";

Sub-part 7: "Radio Subsystem Synchronization; GMR-1 05.010";

Part 6: "Speech coding specifications";

Part 7: "Terminal adaptor specifications".

Introduction

GMR stands for GEO (Geostationary Earth Orbit) Mobile Radio interface, which is used for mobile satellite services (MSS) utilizing geostationary satellite(s). GMR is derived from the terrestrial digital cellular standard GSM and supports access to GSM core networks.

Due to the differences between terrestrial and satellite channels, some modifications to the GSM standard are necessary. Some GSM specifications are directly applicable, whereas others are applicable with modifications. Similarly, some GSM specifications do not apply, while some GMR specifications have no corresponding GSM specification.

Since GMR is derived from GSM, the organization of the GMR specifications closely follows that of GSM. The GMR numbers have been designed to correspond to the GSM numbering system. All GMR specifications are allocated a unique GMR number as follows:

GMR-n xx.zyy

where:

- xx.0yy ($z = 0$) is used for GMR specifications that have a corresponding GSM specification. In this case, the numbers xx and yy correspond to the GSM numbering scheme.
- xx.2yy ($z = 2$) is used for GMR specifications that do not correspond to a GSM specification. In this case, only the number xx corresponds to the GSM numbering scheme and the number yy is allocated by GMR.
- n denotes the first ($n = 1$) or second ($n = 2$) family of GMR specifications.

A GMR system is defined by the combination of a family of GMR specifications and GSM specifications as follows:

- If a GMR specification exists it takes precedence over the corresponding GSM specification (if any). This precedence rule applies to any references in the corresponding GSM specifications.

NOTE: Any references to GSM specifications within the GMR specifications are not subject to this precedence rule. For example, a GMR specification may contain specific references to the corresponding GSM specification.

- If a GMR specification does not exist, the corresponding GSM specification may or may not apply. The applicability of the GSM specifications is defined in GMR-1 01.201 [7].

1 Scope

The present document presents the requirements for synchronizing timing and frequency between the MES and the Gateway Station (GS) in the GMR-1 Mobile Satellite System.

2 References

The following documents contain provisions which, through reference in this text, constitute provisions of the present document.

- References are either specific (identified by date of publication and/or edition number or version number) or non-specific.
- For a specific reference, subsequent revisions do not apply.
- For a non-specific reference, the latest version applies.

- [1] GMR-1 01.004 (ETSI TS 101 376-1-1): "GEO-Mobile Radio Interface Specifications; Part 1: General specifications; Sub-part 1: Abbreviations and acronyms; GMR-1 01.004".
 - [2] GMR-1 04.008 (ETSI TS 101 376-4-8): "GEO-Mobile Radio Interface Specifications; Part 4: Radio interface protocol specifications; Sub-part 8: Mobile Radio Interface Layer 3 Specifications; GMR-1 04.008".
 - [3] GMR-1 05.002 (ETSI TS 101 376-5-2): "GEO-Mobile Radio Interface Specifications; Part 5: Radio interface physical layer specifications; Sub-part 2: Multiplexing and Multiple Access; Stage 2 Service Description; GMR-1 05.002".
 - [4] GMR-1 05.003 (ETSI TS 101 376-5-3): "GEO-Mobile Radio Interface Specifications; Part 5: Radio interface physical layer specifications; Sub-part 3: Channel Coding; GMR-1 05.003".
 - [5] GMR-1 05.005 (ETSI TS 101 376-5-5): "GEO-Mobile Radio Interface Specifications; Part 5: Radio interface physical layer specifications; Sub-part 5: Radio Transmission and Reception; GMR-1 05.005".
 - [6] GMR-1 05.008 (ETSI TS 101 376-5-6): "GEO-Mobile Radio Interface Specifications; Part 5: Radio interface physical layer specifications; Sub-part 6: Radio Subsystem Link Control; GMR-1 05.008".
 - [7] GMR-1 01.201 (ETSI TS 101 376-1-2): "GEO-Mobile Radio Interface Specifications; Part 1: General specifications; Sub-part 2: Introduction to the GMR-1 Family; GMR-1 01.201".
-

3 Definitions and abbreviations

3.1 Definitions

For the purposes of the present document, the following terms and definitions apply:

SB_FRAME_TS_OFFSET: offset between downlink frame N and uplink frame N+7 at the spot-beam centre, measured in number of timeslots

SB_SYMBOL_OFFSET: additional offset between downlink frame N and uplink frame N+7 at the spot beam centre, measured in number of symbols

RACH_TS_OFFSET: RACH window offset relative to the start of BCCH window within the same frame, measured in number of timeslots

RACH_SYMBOL_OFFSET: RACH timing offset in symbols. The offset between RACH window and the start of the reference frame seen from the MES. Measured in number of symbols

RACH_SYMBOL_OFFSET: RACH timing offset in number of symbols. The offset between RACH transmission timing and the start of the reference frame seen from the MES. This is not part of the system information

SA_BCCH_STN: BCCH window offset relative to the start of the frame, in number of timeslots

SA_SIRFN_DELAY: within each multiframe, the first FCCH channel frame number relative to the start of the multiframe

SA_FREQ_OFFSET: twice of the downlink beam centre Doppler due to satellite motion only

Pre-correction Indication: timing delay pre-compensated by the MES in the RACH transmission

Timing Offset: timing correction sent over AGCH channel

Frequency Offset: frequency correction sent over AGCH channel

Timing Correction: in-call timing correction sent over FACCH channel

Frequency Correction: in-call frequency correction sent over FACCH channel

Guard Time Violation: message to indicate the violation of Rx/Tx burst guard time

3.2 Abbreviations

For the purposes of the present document, the abbreviations and acronyms given in GMR-1 01.004 [1] and the following apply. For mapping of GSM terms to GMR-1, refer to terminology cross-reference table in GMR-1 01.201 [7].

AGCH	Access Grant Channel
BACH	Broadcast Alert Channel
BCCH	Broadcast Control Channel
BN	Bit Number
CCCH	Common Control Channel
DKAB	Dual Keep-Alive Burst
FACCH	Fast Access Control Channel
FC	Frequency Correction
FCCH	Frequency Control Channel
FN	Frame Number
GSC	Gateway Station Controllers
GS	Gateway Station
GtT	Gateway-to-Terminal call
MES	Mobile Earth Station
PAN	Power Attenuation Notification
PAR	Power Attenuation Request
PCH	Paging Channel
RACH	Random Access Channel
RF	Radio Frequency
RTD	Round Trip Delay
SACCH	Slow Access Control Channel
SDCCH	Standalone Dedicated Control Channel
TC	Timing Correction
TCH	Traffic Channel
TDMA	Time Division Multiple Access
TN	Timeslot Number
TS	Timeslot
TTCH	Terminal-to-Terminal Channel
TtG	Terminal-to-Gateway call
TtT	Terminal-to-Terminal call

4 General description of synchronization system

GeoMobile (GMR-1) is a multi-spot beam, multicarrier, synchronous system where the timing and frequency on the satellite serve as the reference to synchronize the TDMA transmissions for the MESs, the network GSs and other network elements. The satellite includes a switch designed to provide single-hop, TtT connectivity at L-band. The TDMA satellite switch permits the selection of connection patterns between any slot in the TDMA frame of an L-band return carrier in one spot beam to any other slot in the TDMA frame of an L-band forward carrier in the same spot beam or any other spot beam.

Synchronization in the GMR-1 system is composed of four major tasks:

- Timing Synchronization;
- Frequency Synchronization;
- Frame Synchronization;
- Message Synchronization.

A master oscillator onboard the GMR-1 spacecraft is the primary reference for all synchronization processes. The fundamental goal of synchronization is to have gateways and mobile earth stations alike operate such that all bursts arrive at the satellite synchronized in timing and frequency.

4.1 System timing structure

The GMR-1 satellite system is a TDMA system. Timing configuration in the system is composed of hyperframe, superframe, multiframe, frame, timeslot, symbol and bit. A hyperframe is the longest repetition time period and 1/40 symbol duration is the smallest measurable and adjustable unit in the system.

A hyperframe has a duration of 3h 28mn 53s 760 ms, it contains 4 896 superframes, 19 584 multiframe or 313 344 TDMA frames. One superframe equals to 2,56 s, including four multiframe or 64 TDMA frames. One multiframe includes 16 TDMA frames and each TDMA frame has 24 timeslots. The TDMA frame duration is 40 ms, one timeslot duration is approximately 1,67 ms. In each timeslot, there are 39 symbols, each symbol corresponds to 2 bits. The complete timeframe structure can be seen from the graph shown in GMR-1 05.002 [3].

A superframe always starts from the frame that meets $FN \bmod 64 = 0$. Within the superframe, the first frame is also the beginning of the first multiframe with multiframe number 00.

4.2 Timebase counter

The timing state of the signals transmitted by the MES and satellite is defined by the following counters:

- Bit counter BN (0-77);
- Timeslot counter TN (0-23);
- TDMA frame counter FN (0-313 343).

The relationship between these counters is as follows:

- BN increments every $5\,000/234\ \mu\text{sec}$;
- TN increments whenever BN changes from count 77 to 0;
- FN increments whenever TN changes from count 23 to 0.

The MES can use the timing of the receipt of the BCCH burst to set up its timebase counters as follows:

- BN is set by the timing of the FCCH timing acquisition;
- TN is set by the timeslot number that is contained in the information fields of the BCCH burst;
- FN is set by the frame number derived from the information fields of the BCCH bursts.

The frame number field definition is given in GMR-1 04.008.

4.3 General requirement

4.3.1 Timing and frequency reference point

The satellite is selected to be the reference point for both timing and frequency. For downlink signals, the reference point is the output of the satellite L-band antenna. For uplink signals, the reference point is the input of the satellite L-band antenna.

4.3.2 MES requirement

- Both transmitter and receiver timing shall be derived from the same timebase.
- Both transmitter and receiver frequency shall be derived from the same frequency source.
- The MES shall use the same source for both RF frequency generation and clicking the timebase.
- All return link signals (control channel and traffic channel) transmitted from the MESs shall achieve frame/timeslot alignment on the satellite timing reference point, i.e., input of satellite antenna.
- In various operation modes, synchronization shall be maintained under the worst case timing and frequency drift rate due to MES-satellite relative motion and MES master oscillator stability. The MES oscillator long term stability shall be better than 5 ppm. The MES oscillator short-term stability shall maintain all timing offset, frequency offset and symbol rate requirement specified in GMR-1 05.005 [5] in the absence of received signal up to 5 seconds. The maximum timing drift rate due to MES-satellite relative motion is 0,32 $\mu\text{s}/\text{sec}$. The maximum frequency drift rate due to MES acceleration is 24,6 Hz/sec.

4.3.3 Network requirement

- All forward link signals (control channel and traffic channel) transmitted from the network shall achieve frame/timeslot alignment on the satellite timing reference point, i.e., output of satellite antenna.
- Both forward and return link signals shall be adjusted by the network to maintain a fixed frame and slot relative timing on the satellite timing reference point. This adjustment shall be capable of handling the worst case timing and frequency drift caused by satellite motion and user motion.
- Forward and return link timeslots shall be assigned by the network to meet the follows: A 2,2 ms guard time shall be left for the MES to switch between transmit and receive frequencies. A 1,6 ms guard time shall be left for the MES to switch between two different receive frequencies.
- At the initial call setup, the network shall be able to estimate the RACH signal arrival to the accuracy better than 12,6 Hz 1-sigma in frequency, 3,6 μs 1-sigma in timing, under the condition of AWGN channel.

4.3.4 Measurement conditions

- In the following, all timing and frequency related parameters are defined under the condition of AWGN channel, with $E_b / N_0 = -0,5 \text{ dB}$.
- In the following, unless specifically specified, all timing and frequency related parameters are defined as 1-sigma value.

5 Timing synchronization, TtG/GtT call

The general requirement for MES timing synchronization is that the MES shall transmit signals that are time aligned and frame number aligned with the system timing on the satellite reference point.

The MES timing alignment is achieved by correcting transmission timing with factors provided by a GS. RACH timing is setup by factors provided over the BCCH. TCH or SDCCH timing is corrected with corrective factors given over the AGCH. During a call, timing correction is provided by FACCH (TCH3) or SACCH (TCH6/TCH9).

The GS transmits a frame number on the BCCH which is received and used by the MES to establish its local frame numbering process.

5.1 General description

The whole system is synchronized on the satellite. The network adjusts FCCH and BCCH transmission so that each of these channels leaves from the satellite antenna at the predefined system timing. An MES derives its local timing reference from the signals received from the satellite. By listening to the FCCH, both timing and frequency synchronization can be achieved for CCCH channels.

From a cold start, MESs initially search for and acquire the FCCH sent in each spot beam. The MES's frame timing is then synchronized to system timing.

In idle mode, after initial timing acquisition, the MES needs to track system timing continuously in order to compensate the timing drift caused by its local oscillator frequency uncertainty and the relative motion between the satellite and the user.

At initial access, an MES accesses the network using a RACH offset pre-calculated for the spot beam centre. This RACH offset is distributed from the network in each spot beam and it is available at the MES soon after it decodes the BCCH. The round trip delay variation caused by the difference of MES position relative to the beam centre shall be detected from the network, and this value shall be passed to the MES as a timing correction. After the RACH process, the MES shall be able to transmit such that timing of burst arrival on the satellite is nominal.

At the beginning of a call, to achieve frame/timeslot synchronization on the satellite, a transmission frame offset relative to the start of downlink reference frame is provided from the network. During a call, both MES transmitter and receiver adjust their burst timing to maintain the frame/timeslot synchronization. The MES receiver timing is maintained by using its internal timebase. Meanwhile, timing detection technique of voice or DKAB bursts is used to monitor any possible timing drift caused by the MES oscillator, and by MES-satellite relative motion. For the MES transmitter, a closed loop synchronization scheme is adopted. Any transmission timing drift at the MES shall be detected from the network by comparing the actual burst arrival with the expected arrival, and a timing correction is passed to the MES if the difference exceeds a threshold defined by the network.

To reduce the number of timing correction due to satellite motion, Doppler frequency received from AGCH is used to determine the timing drift rate. During a call, this timing drift rate is used to correct transmission timing.

The following symbolic definitions apply to the rest of the sections. T_F : frame duration, T_S : timeslot duration, T_{SB} : symbol duration, T_0 : propagation delay from the satellite to the beam centre, T_U : propagation delay from the satellite to the MES.

5.2 Timing of forward link common channels

The timing of forward link common channels is defined in GMR-1 05.002 [3]. An outline is given below for convenience.

The BCCH/CCCH bursts occupy six consecutive timeslots. In each spot beam, a set of common channels are defined: FCCH, BCCH, PCH, BACH and AGCH. These channels follow a fixed repetition pattern with repetition duration equals to one superframe. Position of BCCH and FCCH between neighbouring beams shall be offset in frames as well as in timeslots to facilitate MES fast timing/frequency acquisition and satellite power spread in time.

5.2.1 FCCH/BCCH timing

For FCCH/BCCH timing, refer to GMR-1 05.002 [3].

5.2.2 CCCH timing

Timing of PCH/BACH/AGCH channels is similar to BCCH timing, but with a fixed distance to the BCCH position. The distance is given in integer number of frames. Refer to GMR-1 05.002 [3].

5.3 Idle mode timing synchronization

5.3.1 Initial timing acquisition

The MES shall keep its internal timebase in line with the system timing derived from the BCCH control carrier. For initial timing acquisition, the MES looks for one control carrier with the highest BCCH signal level. Through FCCH acquisition procedure, the MES is then locked to this carrier in both frequency and timing.

The initial timing acquisition procedure has been given in GMR-1 05.008 [6].

5.3.2 Paging mode

In entering paging mode, the timing synchronization in the MES has already been achieved from the FCCH channel detection. The MES shall track the system timing by listening to either PCH or BCCH channel periodically.

In case of losing synchronization, the MES shall make use of the stored information (frequency, timing) in order to re-establish synchronization as quickly as possible. This process is described in GMR-1 05.008 [6].

In paging mode, the MES receiver timing relative to the received signal shall be accurate enough so that demodulation performances specified by GMR-1 05.005 [5] can be achieved. The MES tracking loop shall be able to handle the worst case timing drift rate due to MES-satellite relative motion and MES oscillator stability, their maximum values are specified in clause 4.3.2.

5.3.3 Alerting mode

When the MES can no longer demodulate BCCH or PCH information from its serving beam or from any one of the neighbouring beams, the MES shall enter alerting mode. To achieve alerting mode synchronization, the MES shall use the timing information derived from the FCCH channel to estimate the timing of the BACH channel.

In alerting mode, the MES shall track the system timing by listening to the FCCH channel periodically. The derived system timing shall be used to update its internal timebase.

The alerting message for each alerting group is transmitted over 15 bursts; each burst occupies two timeslots. The 15 bursts are spread over five different frames within one superframe, 3 bursts for each frame (see GMR-1 05.002 [3] for details). Within each super frame, the frame number of the five transmission frames is given in table 5.1.

Table 5.1

Alerting Group	Frame Number	Alerting Group	Frame Number
BACH0	1, 5, 17, 33, 49	BACH4	3, 15, 19, 35, 51
BACH1	6, 21, 22, 38, 54	BACH5	7, 23, 31, 39, 55
BACH2	9, 25, 37, 41, 57	BACH6	11, 27, 43, 47, 59
BACH3	14, 30, 46, 53, 62	BACH7	13, 29, 45, 61, 63

In alerting mode, the MES receiver timing relative to the received signal shall be accurate enough so that demodulation performances specified by GMR-1 05.005 [5] can be achieved. The worst-case timing drift rate to be handled by the MES tracking loop is the same as that for paging mode.

5.4 Synchronization at initial access

5.4.1 Synchronization process

The synchronization process at initial access is performed according to several different steps: RACH burst transmission, network measurement and return link timing correction. The timing relationship is shown in figure 5.1. These procedures are outlined below.

- The common signalling channel leaves the satellite antenna at the system timing. This signal arrives at the spot beam centre after a propagation delay T_0 , and arrives at the MES after T_U .
- The MES offsets its RACH transmission relative to the start of the received control channel reference frame by RACH_SYMBOL_OFFSET. RACH_SYMBOL_OFFSET is calculated at the MES based on parameters received from the BCCH channel.
- Because of the difference between the MES position and the spot beam centre, the RACH signal arrives at the satellite antenna with a timing error, $2[T_U - T_0]$ the round-trip differential delay from the user to the beam centre.
- The GS measures the difference between the actual RACH burst arrival and the expected arrival if the MES is located at the beam centre, $2[T_U - T_0]$. This difference is then passed to the MES through Timing Offset of the "IMMEDIATE ASSIGNMENT" signalling message via AGCH channel.
- The MES offsets its SDCCH/TCH transmission by $2[T_U - T_0]$. Mobile uplink timing synchronization is achieved at this point.

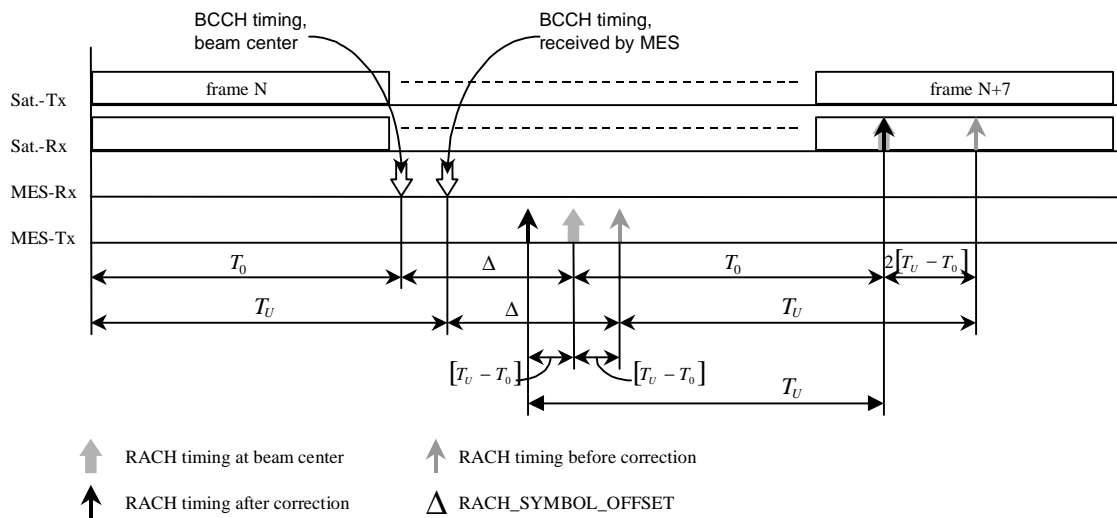

Figure 5.1: Initial timing synchronization process

5.4.2 RACH timing pre-correction

The RACH burst has a length of 9TS. To fit this 9TS burst into a 12 (or 18) TS RACH window, $\pm 1,5TS$ (or $\pm 4,5TS$) is left to accommodate user position variation within a spotbeam. For most of the spotbeams, propagation delay variation is far beyond this range, therefore the MES shall pre-compensate part of the delay variation to fit RACH burst into the RACH window. The MES shall be able to estimate its differential delay relative to spotbeam centre with reasonable accuracy and compensate this differential delay in its RACH transmission. With this compensation, the RACH window shall be able to accommodate the whole range of delay variation. For more details on the differential delay measurement, see GMR-1 05.008 [6].

A parameter Precorrection Indication shall be included in the RACH transmission burst. This is half of the actual timing value the MES compensates in its RACH transmission. The goal is to inform the GS about its pre-compensation so that the measurement of absolute propagation delay is made possible at the GS.

The parameter Precorrection Indication has 3 bits. Its coding is shown below.

Table 5.2: Coding of the parameter RACH_correction

Code	Compensation	Code	Compensation
000	0 symbols	100	+141 symbols
001	-47 symbols	101	+94 symbols
010	-94 symbols	110	+47 symbols
011	-141 symbols	111	reserved

The value of this parameter shall be derived at the MES based on one way differential delay measurement relative to spotbeam centre. The differential delay measurement is first converted into the number of symbols, then the closest value of Precorrection Indication is selected from all seven possible correction levels shown in above table.

If dt_0 is the one-way propagation differential delay relative to beam centre measured in the unit of milli-second (see GMR-1 05.008 [6]), then dT_0 , the same differential delay but in the unit of symbol can be converted as:

$$dT_0 = \text{round} \left(\frac{117}{5} \times dt_0 \right)$$

This differential delay dT_0 is then graded into the closest level of Precorrection Indication, denoted as dT_1 . The actual value of MES pre-correction is $2 \times dT_1$. Converting from dT_0 to dT_1 is based on the following:

$$dT_1 = 47 \times \text{round} \left(\frac{dT_0}{47} \right)$$

If Timing Offset received from AGCH is dT_2 , then the MES shall offset its SDCCH/TCH transmission by $2 \times dT_1 + dT_2$ relative to its RACH transmission timing.

After receiving the RACH signal, the GS shall measure the difference between the actual burst arrival and the expected arrival, denoted as dT_2 , and decode the parameter Precorrection Indication to obtain the value of dT_1 . The value of dT_2 shall be passed to the MES via AGCH. Both dT_1 and dT_2 shall be used by the GS to calculate MES-satellite propagation delay T_U according to the following equation:

$$T_U = T_0 + dT_1 + \frac{dT_2}{2}$$

where T_0 is the beam centre propagation delay.

5.4.3 Description of parameters

Figure 5.2 shows the time offset between the transmit and received frame for an MES experiencing an overall delay of between 119,37 and 135 milliseconds. The 5-bit parameter *SB_FRAME_TS_OFFSET* indicates to the MES, the offset, in slots, between the forward link timeslot 0 in $FN = N$ and the return link timeslot 0 in $FN = N+7$ nominally at the centre of the spot beam. The value of this parameter varies between 6 and 28. In addition to *SB_FRAME_TS_OFFSET*, a 6-bit parameter *SB_SYMBOL_OFFSET* indicates to the MES, an additional offset in symbol periods nominally at the centre of the spot beam. The *SB_SYMBOL_OFFSET* varies between -32 to +31 symbols. The parameter *RACH_TS_OFFSET* indicates to the MES the start of RACH window relative to the start of the BCCH window, ranges from 0 to 23. All of these parameters are broadcast from the BCCH. Based on these parameters, the MES can calculate the offset between forward and return frames to within 1 symbol period if it is at the centre of the spot beam.

To accommodate satellite diurnal motion, the two parameters *SB_FRAME_TS_OFFSET* and *SB_SYMBOL_OFFSET* shall be calculated dynamically at the GS based on satellite and beam centre instantaneous relative distance. These values are periodically updated through BCCH so that the RACH burst sent by MES is always centred at the middle of the RACH window if the MES is located at beam centre.

The MES shall calculate the start of the RACH burst transmission referenced to the start of timeslot 0 on the forward channel in units of symbol periods, *RACH_SYMBOL_OFFSET*, using the following formula:

$$RACH_SYMBOL_OFFSET = \\ SB_SYMBOL_OFFSET + 2 \times RACH_CORRECTION \\ 39 \times (SB_FRAME_TS_OFFSET + SA_BCCH_STN + RACH_TS_OFFSET + R)$$

This is the number of symbols that an MES shall delay the start of a RACH burst (with K timeslots) in frame number M relative to the start of the received frame number N. This transmission shall be in the return link timeslot $(SA_BCCH_STN + RACH_TS_OFFSET + R) \bmod 24$. A factor R is introduced in the calculation in order to centre the K timeslots RACH burst within the 12 TS RACH window. Relationship between R and K is given as $R = (12-K)/2$.

If the value of $(SA_BCCH_STN + RACH_TS_OFFSET + R) < 24$, the MES shall use frame number $M = N+7$. If the value of $(SA_BCCH_STN + RACH_TS_OFFSET + R) \geq 24$, the MES shall use frame number $M = N+8$. Therefore if the RACH burst crosses the uplink frame boundary, the frame number used by the RACH burst is determined by the start of RACH transmission. The range of parameters relating to initial access is shown in table 5.2.

During the initial access, Timing Offset $2[T_U - T_0]$ is provided from the network via AGCH. From annex B, the value of this correction factor varies from 0 to $\pm 9,73$ ms. To handle unexpected situations, in practice the designed range shall leave enough margin and therefore ± 17 ms is considered. This requires 15 bits to inform the MES, with unit of $T_{SB}/40$ (1.075 μ s), and a range from -15 912 to +15 912.

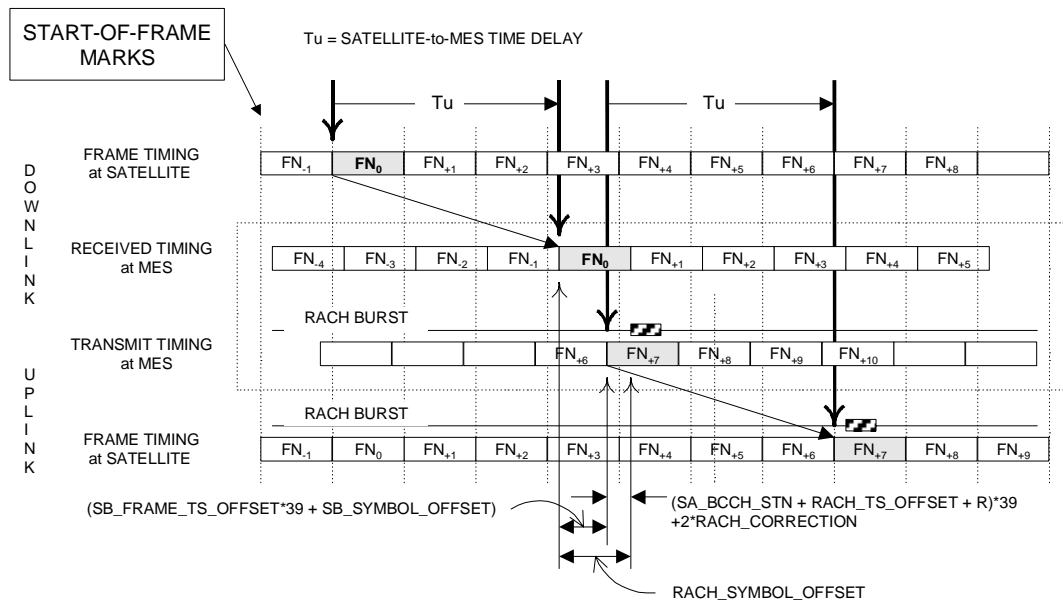

Figure 5.2: RACH burst timing

Table 5.3: Range of parameters at initial access

Parameter	Unit	Range
SB_FRAME_TS_OFFSET	TS	6 to 28
SB_SYMBOL_OFFSET	Symbol	-32 to +32
SA_BCCH_STN	TS	0 to 23
RACH_TS_OFFSET	TS	0 to 23
M - N	Frame	7 to 8
RACH_SYMBOL_OFFSET	Symbol	(202+R*39) to (2 918+R*39)

5.4.4 Timing accuracy

From the MES, BCCH timing is used as timing reference for RACH burst transmission. The timing error is dominated by several factors: BCCH signal timing error, BCCH timing detection error introduced by the MES, timing drift due to MES oscillator stability and differential delay from the MES to beam centre. The network shall be able to measure the overall timing error to the accuracy better than 3,6 μs 1-sigma. After receiving the timing correction from the AGCH, the MES shall adjust its SDCCH/TCH transmission timing to the accuracy better than 4,6 μs 1-sigma relative to the system timing.

5.5 Dedicated mode synchronization

In call, to accurately maintain the correct time alignment at the satellite, the MES advances or retards the transmission of bursts relative to the start of its reference frame to synchronize their arrival at the reference point of the satellite.

The forward and return frames are offset relative to each other at the MES. This offset is provided to meet the following basic system requirements:

- Achieve time synchronization of the forward and return frames and slots at the satellite reference point.
- Permit a low-complexity MES implementation that eliminates the need for a frequency diplexer (an MES is not required to transmit and receive at the same time), which also allows simple synthesizers to switch frequencies in the proper time intervals.
- Allow MESs to monitor the assigned TTCH channel during a TtT call.

In dedicated mode, either voice channel or SDCCH channel is used. Synchronization scheme addressed below applies to both of these two channels.

5.5.1 In-call timing relationship

In figure 5.3, ΔT_{OF} is the transmission frame offset relative to the start of the received reference frame at the MES.

K_D and K_U are the forward and return link burst positions, the values of K_D and K_U are allocated by the network at the beginning of the call, they are all numbered from 0 to 23.

The system requires that transmission burst corresponding to the received burst from frame N arrives in frame N+7 on the satellite. Therefore if an MES receives a frame with frame number N, it shall offset its transmitted frame by ΔT_{OF} to achieve frame synchronization on the satellite.

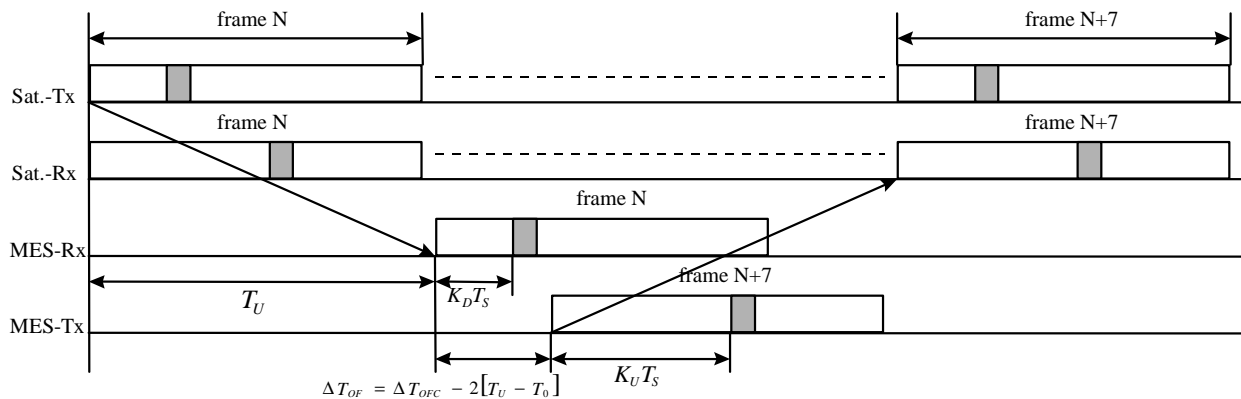

Figure 5.3: Frame and burst timing on the satellite and the MES

The offset between frame N+7 uplink and frame N downlink shall be calculated from:

$$\Delta T_{OF} = RACH_SYMBOL_OFFSET - 2[T_U - T_0],$$

where parameter RACH_SYMBOL_OFFSET is calculated from equation given in clause 5.4.3.

After initial access, the MES shall derive the frame offset ΔT_{OF} based on the corrective factor $2[T_U - T_0]$ received from the AGCH. During the call, the value of $2[T_U - T_0]$ is updated via FACCH messages (TCH3) or SACCH message (TCH6/TCH9) to compensate any timing drift caused by MES oscillator, MES-satellite relative motion.

5.5.2 In-call synchronization scenario

In the downlink, an open-loop synchronization scheme is used. The MES receiver timing is still derived from its internal timebase, but frequently corrected by timing detection of the received TCH or DKAB bursts during the call. The task of receiver timing correction shall be performed often enough to handle the worst case timing drift rate specified in clause 4.3.2. The target timing accuracy is to achieve demodulation performances specified by GMR-1 05.005 [5].

In the uplink, a closed-loop synchronization scheme is used. The synchronization process is detailed below.

- After RACH process, the MES transmitter has already synchronized to system timing. If T_a is the expected burst arrival time on the satellite, then the MES shall start its burst transmission at $T_a - T_u$.
- Sometime later, because of the user motion and its oscillator stability, the MES receiver timing is offset by $\Delta T_U = \Delta T_{U1} + \Delta T_{U2}$ from its original timing, where ΔT_{U1} is due to its internal oscillator drift and timing tracking error, ΔT_{U2} is due to a change of the MES position.
- Since the MES transmitter uses receiver timing as reference, then the MES transmission timing also offsets by $\Delta T_U = \Delta T_{U1} + \Delta T_{U2}$. Burst transmission timing becomes to be $T_a - T_u + \Delta T_{U1} + \Delta T_{U2}$.

- After experiencing an uplink propagation delay $T_U + \Delta T_{U2}$, the signal arrives on the satellite at $T_a + \Delta T_{U1} + 2\Delta T_{U2}$, offsets from the nominal timing by $\Delta T_{U1} + 2\Delta T_{U2}$.
- At the GS, difference between the actual burst arrival and expected arrival shall be monitored. If the GS has detected that the difference $\Delta T_{U1} + 2\Delta T_{U2}$ exceeds a predefined threshold of 10 μs , it shall pass the difference to the MES through a Timing Correction message via FACCH3, SACCH6/9 or SDCCH.
- After receiving the Timing Correction, the MES shall offset its transmission by $\Delta T_{U1} + 2\Delta T_{U2}$ in timing. This timing adjustment shall be achieved gradually. The adjustment shall be made at a rate of 2 $\mu\text{s}/\text{sec} \pm 0,2 \mu\text{s}/\text{sec}$, the RMS error between the actual transmission timing and the 2 $\mu\text{s}/\text{sec}$ profile shall be less than 0,5 μs over the duration of adjustment. This rate of change shall be made in addition to the Doppler-related rate-of-change which is applied to the MES transmission timing continuously.
- The adjustment shall be applied to the MES transmission in such a way: if the Control Flag associated with the Timing Correction message is 1, then this message overrides all previous messages; Otherwise, if the Control Flag is 0, the adjustment shall be made in addition to any previous messages.
- After this adjustment, the MES transmission timing becomes $T_a - T_U - \Delta T_{U2}$. With an uplink propagation delay $T_U + \Delta T_{U2}$, the burst arrives on the satellite at nominal timing T_a .

The task of transmission timing correction shall be performed often enough to cope with the worst-case timing drift specified in clause 4.3.2. As the maximum timing drift rate in the mobile's downlink is 0,32 $\mu\text{s}/\text{sec}$, the transmission timing drift rate can be up to 0,64 $\mu\text{s}/\text{sec}$. With this correction, a transmission timing accuracy relative to the system timing specified by GMR-1 05.005 [5] shall be achieved.

In the FACCH or SACCH channel, the Timing Correction message shall be provided by the network relative to the currently used transmission timing value, this is different from the correction transmitted over AGCH. The range of the timing adjustment shall be from $-32 T_{SB} / 40$ to $+31 T_{SB} / 40$, with a unit of $T_{SB} / 40$, which requires 6 bits. When the MES receives a new value of Timing Correction, it shall apply the change within 80 ms after receiving the message. Suppose this message has been successfully received and has been applied to the MES transmitter, the GS shall be able observe this adjustment sometime later.

When the GS instructs an MES to switch from one channel to another (i.e., from SDCCH to TCH), a Timing Correction message shall be provided to the MES. Then the MES shall apply the new TC to the new channel.

5.5.3 Transmission timing drift rate

In call, to reduce the number of FACCH messages and to improve timing accuracy and stability of MES transmission, the MES timing drift rate shall be used for transmission timing correction. This timing drift rate R shall be derived from the Frequency Correction message received from AGCH channel as well as FACCH (SACCH) according to the following.

The drift rate of timing depends on the exact carrier frequency being used. In using the following equations, the terminal shall presume *drift_factor* to be either of the following values:

- The value of the current transmit frequency expressed in GHz, or
- 1,6345.

The former choice is preferable; however, the latter choice is an acceptable compromise value. The total error in the determination of R (assuming the frequency adjustments are correct) should not exceed 8 nanoseconds per second from this. Note that transmit timing is limited by the quantization of the hardware and errors in the estimators and tracking loops. Therefore, conformance to this requirement should be tested using periods of several minutes. For example, the error after 1 000 seconds should be less than 8 microseconds.

After the RACH process, the value of Frequency Correction message received from AGCH is ΔF_1 , ΔF_0 is the round trip Doppler experienced by a stationary MES located at beam centre, it is broadcast through BCCH and therefore available by the MES prior to each call. Then the timing drift rate R is:

$$R = \frac{\Delta F_1 + \Delta F_0}{\text{drift_factor}} (\text{ns/sec}).$$

During a call, after an MES has received a Frequency Correction message ΔF_2 from the FACCH or SACCH channel, this message shall be used to calculate the delta value of timing drift rate, denoted as ΔR . This delta value shall be calculated as:

$$\Delta R = \frac{\Delta F_2}{\text{drift_factor}} (\text{ns/sec}).$$

The timing drift rate R shall be adjusted as:

$$R = [R + \Delta R] (\text{ns/sec}).$$

The accumulated frequency offset is equal to the offset being applied (in Hz) to the transmitter at any time (based on the estimated received frequency). Therefore, the MES does not need to separately accumulate the values it has received via the BCCH, AGCH, and control messages.

The MES shall apply this new timing drift rate to its transmission timing within 80 ms after the Frequency Correction message is received. The adjustment shall be made relative to receive timing.

5.5.4 RX/TX guard time violation

A guard time of 2,2 ms is required by the terminal to switch from one receive frequency to another transmission frequency. Due to MES-satellite relative motion, the RX burst and TX burst move relative to each other so that the RX/TX guard time may finally violate the minimum required guard time limitation. In the worst case, the relative moving speed between the two bursts is 0,64 $\mu\text{s}/\text{sec}$, twice the rate of propagation delay change.

From the MES, the available RX/TX guard time shall be monitored at least once every 15 seconds. If the guard time is found to be smaller than a predefined threshold $2\ 200 + T_{\text{gt}} \mu\text{s}$, where T_{gt} is the additional guard time left for signalling exchange, a `GUARD_TIME_VIOLATION` message shall be sent from the MES to the network notifying about this violation. The value of T_{gt} is 15 μs .

5.6 Effect of the half symbol offset

Timing of all traffic channels can be delayed by either 0 or $\frac{1}{2}$ symbol relative to nominal timing. On the forward link, this offset shall be relative to BCCH timing; On the return link, this offset shall be in addition to the correction factor (i.e., the timing offset provided by Timing Correction, see clauses 3.4.1 and 3.5.2 of the present document) used by the MES transmission. The same offset shall be applied to both MES transmitter and receiver. The GS shall not apply a timing offset for any forward/return link common control channels, nor for the SDCCH and TTCH dedicated control channels.

When the GS assigns a traffic channel to an MES, it shall pass a half symbol offset indicator to the MES. This information element indicates to the MES the offset to be used on both the forward and return links.

Based on the indicator, the MES shall be able to adjust its transmitter and receiver timing to accommodate corresponding offset. In the forward direction, the MES shall offset its signal reception of the new channel by either 0 or $\frac{1}{2}$ symbol duration relative to BCCH timing, depending on the content indicated by the half symbol offset indicator. In the return direction, the timing offset applied to the new channel shall be calculated from two parameters: Timing Correction and the half symbol offset indicator. The MES shall offset its transmission timing by a value indicated by Timing Correction, plus an additional 0 or $\frac{1}{2}$ symbol delay determined by the indicator. The MES shall apply the same offset to both the forward and return traffic channel links.

6 Frequency synchronization, TtG/GtT call

Both forward and return link signals are required to align their nominal frequencies on the satellite. The task of frequency synchronization is to precompensate the transmission signal to align the nominal frequency on the satellite and to track the received signal in frequency to achieve effective demodulation.

The MES frequency alignment is achieved by correcting transmission frequency with messages provided by a network. RACH frequency is set up by messages provided over the BCCH. SDCCH/TCH frequency is corrected with corrective factors given over the AGCH. During a call, frequency correction is provided through FACCH (TCH3) or SACCH (TCH6/TCH9).

6.1 General description

Frequency error introduced by MES oscillator: The MES oscillator has an accuracy better than 5 ppm long term. Without any compensation, the first order frequency error can be up to $\pm 7,5$ kHz. After initial frequency acquisition, this uncertainty can be reduced by several orders of magnitude. In this case, the MES receiver and transmitter frequency tolerance under various environmental conditions has been defined in GMR-1 05.005 [5].

Doppler frequency introduced by satellite motion: Due to the satellite motion, a stationary user shall experience a maximum Doppler frequency drift ± 264 Hz downlink, ± 282 Hz uplink.

Doppler frequency introduced by user motion: Due to the user motion, additional Doppler is generated. In the worst case, this frequency error is ± 231 Hz downlink, ± 246 Hz uplink.

6.2 Frequency of common channels

The FCCH/BCCH/CCCH carrier leaves the satellite with its nominal frequency. After experiencing a Doppler drift due to user-satellite relative motion, frequency of the received signal can be off from its nominal value by 495 Hz, worst case, 264 Hz due to satellite motion, and 231 Hz due to user motion.

6.3 Idle mode frequency synchronization

6.3.1 Initial frequency acquisition

In the initial frequency acquisition, an MES looks for one control carrier with the highest signal level. After FCCH acquisition process described in GMR-1 05.008 [6], the MES shall use the BCCH frequency as its frequency reference and locked to the BCCH carrier.

6.3.2 Paging mode

In paging mode, the frequency synchronization in the MES has already been derived from the FCCH channel detection. The MES shall track the frequency of the control carrier by listening to either PCH channel or BCCH channel.

6.3.3 Alerting mode

Based on GMR-1 05.005 [5], in alerting mode, the frequency synchronization in the MES is derived from the FCCH channel detection. The MES shall track the control carrier frequency by listening to the FCCH channel periodically.

In both paging and alerting mode, the MES tracking loop needs to handle the worst case Doppler frequency rate of change specified in clause 4.3.2. The tracking loop shall be implemented in such a way that demodulation performances specified in GMR-1 05.005 [5] can be achieved.

6.4 Synchronization at initial access

Prior to the RACH process, the MES shall receive the RACH frequency and the round-trip L-band Doppler at the beam centre from the BCCH channel. The round-trip beam centre Doppler has a range from -635 to +640 Hz. This requires 8 bits to inform the MES, with stepsize better than 5 Hz. At initial access, the MES accesses the network using the beam centre Doppler as its Doppler precompensation. The MES round trip Doppler variation relative to the beam centre is detected from the network, and this value is passed to the MES as a frequency correction. After the RACH process, the MES shall be able to compensate its frequency drift and Doppler variation to the accuracy of 17,6 Hz 1-sigma (with 12,6 Hz RACH detection error and 5 Hz quantization error) relative to nominal frequency.

6.4.1 Frequency compensation strategy

In general, the frequency compensation strategy shall align the nominal frequencies for both uplink and downlink signals on the satellite, this is shown in figure 6.1. Nominal BCCH receiving frequency is F_B , RACH transmission frequency is F_{RH} , MES traffic channel Tx/Rx frequencies are F_T and F_R , the ratio between F_{RH} and F_B is $\epsilon = F_{RH} / F_B \doteq F_T / F_R$, so that $F_{RH} = \epsilon \cdot F_B$, $F_T = \epsilon \cdot F_R$. In the downlink, Doppler frequency at beam centre due to satellite motion is dF_0 , Doppler perceived by the MES is dF_U . In the uplink, Doppler received by the satellite is $\epsilon \cdot dF_U$. The value of dF_U can have two components: one is due to satellite motion, the other is due to MES motion.

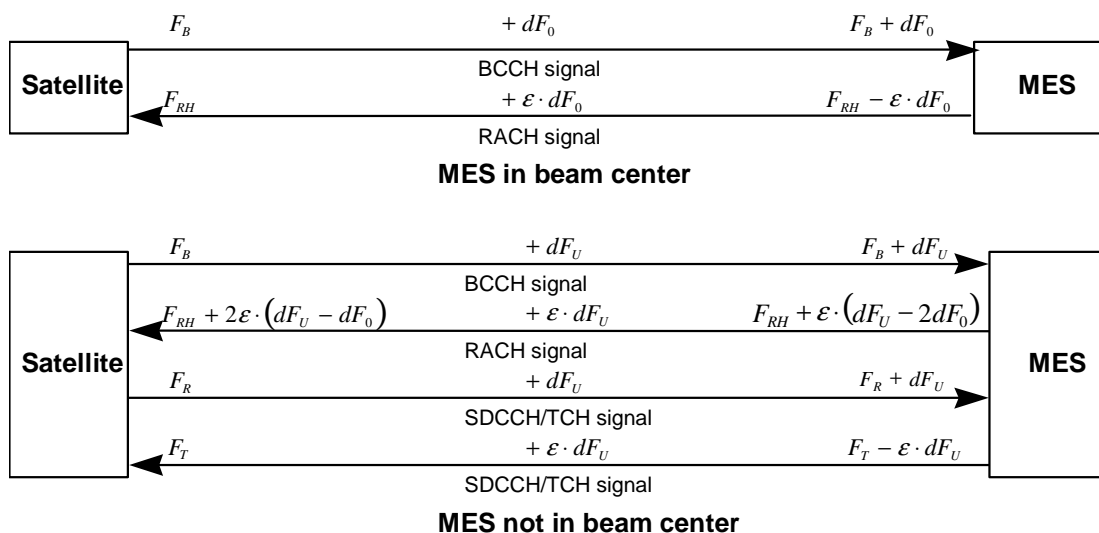

dF_u : Downlink Doppler at UT dF_0 : Downlink Doppler at beam center $\epsilon = F_{RH} / F_B \doteq F_T / F_R$
 F_B : BCCH frequency F_{RH} : RACH frequency
 F_T : MES transmission frequency F_R : MES receive frequency

Figure 6.1: Frequency compensation strategy at initial access

where \doteq represents approximately equal to.

MES frequency compensation scheme is outlined below:

- The GS calculates the mobile downlink beam centre Doppler frequency dF_0 , broadcasts the RACH frequency F_{RH} and the value of $2 \cdot dF_0$, which is twice of the downlink beam centre Doppler, to the MES through the BCCH channel.
- The BCCH signal is received by the MES after experiencing a Doppler shift dF_U , received frequency is then $F_B + dF_U$. For a stationary MES located at beam centre, $dF_U = dF_0$, received frequency is $F_B + dF_0$.
- The MES generates its RACH transmission frequency F_{RH} by multiplying a factor $\varepsilon = F_{RH} / F_B$ from the receiving frequency $F_B + dF_U$, and pre-compensates its RACH Tx frequency by an amount $2 \cdot \varepsilon \cdot dF_0$, resulting in a radiated RACH signal transmission of $F_{RH} + \varepsilon \cdot (dF_U - 2dF_0)$. The MES shall calculate $\varepsilon = F_{RH} / F_B$ in order to apply the precorrection. (For a stationary MES at beam centre, the radiated transmission frequency is simply $F_{RH} - \varepsilon \cdot dF_0$).
- After experiencing Doppler shift $\varepsilon \cdot dF_U$ in the uplink, the RACH signal arrives at the satellite with frequency $F_{RH} + 2\varepsilon \cdot (dF_U - dF_0)$.
- The GS searches for and acquires the MES RACH burst, measures its frequency offset from nominal frequency F_{RH} , and passes a measurement of the quantity $2\varepsilon \cdot (dF_U - dF_0)$ to the MES through AGCH as a FREQUENCY OFFSET.
- The MES switches to the allocated channel (with nominal frequencies F_T and F_R) and offsets its transmission signal by the FREQUENCY OFFSET (approximately $2\varepsilon \cdot (dF_U - dF_0)$) and therefore starts its SDCCH/TCH transmission with frequency $F_T - \varepsilon \cdot dF_U$. After experiencing a Doppler $\varepsilon \cdot dF_U$ on the mobile uplink, the signal arrives in the satellite with nominal frequency F_T .

With this frequency compensation scenario, both forward and return link nominal frequencies take place on the reference point of the satellite.

6.4.2 Parameter description

From the MES, the BCCH carrier is used as frequency reference for RACH transmission. The accuracy of the RACH transmission frequency is influenced by several factors: BCCH carrier frequency error, BCCH frequency detection error introduced by the MES, frequency drift due to MES oscillator stability, differential Doppler from MES to beam centre and Doppler produced by the MES motion.

The network shall be able to measure the above mentioned overall frequency error, the measurement shall be made to the accuracy better than 12,6 Hz 1-sigma. Receiving the frequency correction from the AGCH, the MES shall adjust its frequency of SDCCH/TCH transmission to the accuracy better than 17,6 Hz 1-sigma (with 5 Hz AGCH quantization error) under the condition defined in GMR-1 05.005.

Beam centre Doppler $2 \cdot dF_0$: The maximum downlink beam centre Doppler dF_0 can be up to ± 264 Hz, taking place at the centre of an edge beam. Therefore $2 \cdot dF_0$ is up to ± 528 Hz. To leave enough margin, a range of -640 Hz to +635 Hz is considered, this requires 8 bits to inform the MES through the BCCH, with a stepsize of 5 Hz. To accommodate satellite diurnal motion, the beam centre Doppler shall be calculated dynamically at the GS based on satellite velocity relative to beam centre, the value is periodically updated through BCCH so that the RACH burst arrival on the satellite is always nominal if a stationary MES is located at beam centre.

Frequency correction factor $2\varepsilon \cdot (dF_U - dF_0)$: This factor has two components, one is the user position two way differential Doppler relative to beam centre, the other is the two way Doppler frequency due to mobile user's motion. From annexes A and C, the maximum value of $2\varepsilon \cdot (dF_U - dF_0)$ measured from the network is around ± 600 Hz. Again, to leave enough margin, a range of $-2\,047$ Hz to $+2\,048$ Hz is considered. This frequency correction factor on the AGCH requires 12 bits to inform the MES, with an accuracy better than 1 Hz.

6.5 Dedicated mode synchronization

In call, the accurate receiver frequency is maintained by using its internal frequency reference. Meanwhile, frequency detection technique is used to monitor any possible frequency drift caused by the MES oscillator stability, MES frequency tracking error and Doppler frequency due to MES-satellite relative motion. The MES receiver shall maintain its frequency accuracy relative to the received signal so that demodulation performances specified in GMR-1 05.005 [5] can be achieved.

In the uplink, a closed-loop synchronization scheme is used. The frequency correction procedure is detailed below, figure 6.2 is used as reference.

- After RACH process, MES receive frequency is $F_R + dF_U$, transmission frequency is $F_T - \varepsilon \cdot dF_U$, so that both forward/return link signal frequencies seen from the satellite are nominal: F_R and F_T .
- Sometime later, frequency of the MES receiver is offset by $\Delta dF_U = \Delta dF_{U1} + \Delta dF_{U2}$, where ΔdF_{U1} is due to its internal oscillator drift and receiver's tracking error, ΔdF_{U2} is due to a change of downlink Doppler frequency.
- Since the MES transmitter uses receive frequency as reference, then transmission frequency also offset by $\Delta dF_U = \Delta dF_{U1} + \Delta dF_{U2}$, and becomes to be $F_T' = F_T - \varepsilon \cdot dF_U + \Delta dF_{U1} + \Delta dF_{U2}$.
- After experiencing an uplink Doppler $\varepsilon \cdot (dF_U + \Delta dF_{U2})$, the signal arrives on the satellite with frequency $F_T + \Delta dF_{U1} + (1 + \varepsilon)\Delta dF_{U2}$, offsets from the nominal frequency by $dF = \Delta dF_{U1} + (1 + \varepsilon)\Delta dF_{U2}$.
- At the GS, dF, the difference between actual signal arrival and expected arrival shall be monitored. If the GS detects that the frequency offset dF exceeds a predefined threshold of 40 Hz, it shall pass the value of dF to the MES as a Frequency Correction message via FACCH3, SACCH6/9 or SDCCH. This Frequency Correction shall be relative to the currently used frequency offset, different from the Frequency Correction sent over AGCH channel.
- After receiving the Frequency Correction, the MES shall adjust its transmission to $F_T' - dF$ in frequency, so that MES transmission frequency becomes to be $F_T - \varepsilon \cdot (dF_U + \Delta dF_{U2})$. This frequency adjustment shall be achieved gradually. The adjustment shall be made at a rate of 20 Hz/sec \pm 2 Hz/sec, the RMS error between the actual transmit frequency and the 20 Hz/sec profile shall be less than 1 Hz over the duration of adjustment.
- The adjustment shall be applied to the MES transmission in such a way: if the Control Flag associated with the Frequency Correction message is 1, then this message overrides all previous messages; otherwise, if the Control Flag is 0, the adjustment shall be made in addition to any previous messages.
- After experiencing an uplink Doppler $\varepsilon \cdot (dF_U + \Delta dF_{U2})$, the signal arrives on the satellite with nominal frequency F_T .

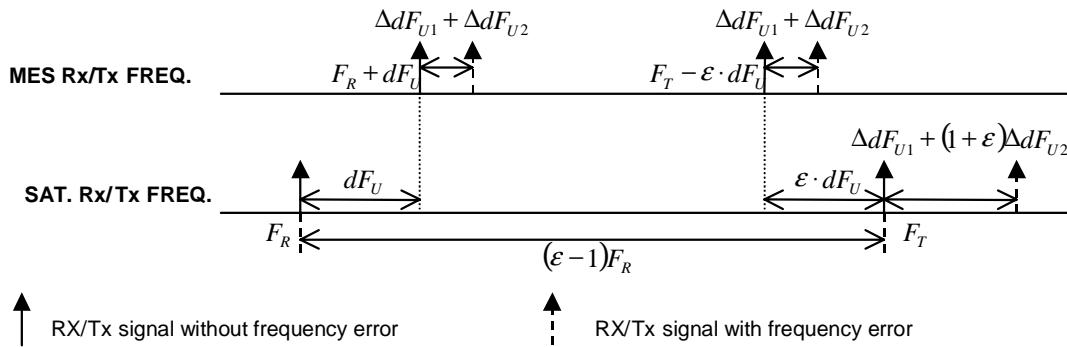

Figure 6.2: In call frequency correction

With the frequency correction technique, accuracy of the MES transmission frequency shall meet the requirement defined in GMR-1 05.005 [5]. The same correction scheme shall be applied to both voice and DKAB transmission. The in-call Frequency Correction message shall have a range from -2 048 Hz to +2 047 Hz, this requires 12 bits to inform the MES, with accuracy better than 1 Hz. For both uplink and downlink signals, the MES tracking loop needs to handle the worst case Doppler frequency change. The maximum Doppler rate of change due to the mobile's acceleration is 23,1 Hz/sec downlink, 49,2 Hz/sec uplink.

When the MES receives a new value of Frequency Correction, it shall apply the change within 80 ms after receiving the message. After this message has been successfully received and has been applied to the MES transmitter, the GS shall be able to observe this adjustment sometime later.

When the GS instructs an MES to switch from one channel to another (i.e., from SDCCH to TCH), a Frequency Correction message shall be provided to the MES. The MES then shall apply the new FC to the new channel.

7 Frame and message synchronization, TtG/GtT call

7.1 Frame synchronization

7.1.1 Frame number definition

Definition of FN is based on the absolute system timing. On the satellite, both forward and return link frames are aligned on the satellite reference point and the same FN is shared by the two frames in both directions. The frame numbering is cycled in a hyperframe duration, $T_{HYP} = 3\text{h } 28\text{mn } 53\text{s } 760\text{ms}$, or 313 344 TDMA frames. If the absolute system timing relative to the start of the system operation is denoted as T in ms., then FN can be given as a function of time T:

$$FN = \text{floor} \left[\frac{T \bmod T_{HYP}}{40} \right]$$

If a traffic burst wraps across the boundary between two frames, frame number applied to the burst is the number of the first frame, i.e., the one with smaller number.

7.1.2 Frame synchronization scenario

The MES frame numbering for both uplink and downlink is purely based on parameters received from the GS.

Idle Mode

In entering idle mode, the MES frame number has been acquired by demodulating parameter Superframe number, Multiframe number and MFFN from the BCCH channel. This parameter is the frame number relative to the start of the hyperframe, its configuration has been introduced in GMR-1 04.008 [2].

In idle mode, the MES RX frame number is maintained by its internal frame counter.

Initial Access

The RACH signal can be transmitted in any frame in the mobile's uplink.

At initial access, the MES first looks for an Rx frame with frame number $FN = N$ as its reference frame. The RACH signal transmission frame number M is then calculated at the MES based on the parameter $RACH_TS_OFFSET$ and SA_BCCH_STN received from the BCCH channel. This task is performed according to the following:

If the value of $SA_BCCH_STN + RACH_TS_OFFSET + R < 24$, the MES shall use $M = N+7$ as its RACH TX frame number.

If the value of $SA_BCCH_STN + RACH_TS_OFFSET + R \geq 24$, the MES shall use $M = N+8$ as its RACH TX frame number.

Definition of R has been given in clause 5.4.3.

To meet the frame number requirement, the MES shall offset its RACH transmission burst relative to the start of the downlink reference frame by $RACH_SYMBOL_OFFSET$ in the unit of symbols. The parameter $RACH_SYMBOL_OFFSET$ is calculated according to clause 5.4.3.

Dedicated Mode

In call, the MES Rx FN is obtained from its internal frame counter, the MES TX FN is calculated based on the Rx FN and transmission frame offset relative to the start of the reference frame, i.e., given in clause 5.5.1. For frame number synchronization purpose, the system requires that the offset between transmission burst with FN $N+7$ and receive burst with FN N equals to. This has been shown in figure 5.3.

The frame number for any RX/TX burst is decided by the start time of the burst. If $T(N)$ is the start time of the Rx frame with $FN = N$ and $T(N+1)$ is the start time of the Rx frame with $FN = N+1$, T_R is the start of an Rx burst, T_T is the start of a TX burst, then the frame number of each burst can be given as:

The Rx burst belongs to frame number N if:

$$T(N) \leq T_R < T(N+1)$$

The TX burst belongs to frame number $N+7$ if:

$$T(N) + \Delta T_{OF} \leq T_T < T(N+1) + \Delta T_{OF} .$$

7.2 Message synchronization

7.2.1 Power control message synchronization

During a call, each power control message takes 6 contiguous frames (240 ms) for transmission, with the messages being sent back-to-back (no gaps).

For message synchronization purpose, one of the two entities involved in the call functions as master and the other one functions as slave. Both shall know their own positions. For TtG or GtT call, the GS functions as master, the MES functions as slave. For TtT calls, the originating MES functions as master, the terminating MES functions as slave. Two different schemes are used to achieve the PC message synchronization. One is applied in the master-to-slave direction, the other is applied to the slave-to-master direction.

Note that for the initial PC message transmissions described below, where PC messages have not yet been received, the transmit PC message shall contain the appropriate value for PAN in the PAN field, and a NULL code in the PAR field. This is true for both master and slave. See GMR-1 04.008 [2] for specification.

7.2.1.1 Synchronization in master-to-slave direction

In the master-to-slave direction, synchronization is based on the frame number. The procedure is outlined below:

- The master entity shall always start its PC message transmission at a frame whose frame number meets: $FN \bmod 6 = 0$.
- The master shall send a PC message at the first timing opportunity to do so, independent of actual PC message reception from the slave.
- The slave entity shall always receive the PC message beginning with the frame whose frame number meets $FN \bmod 6 = L$. For a TtG or GtT call, $L = 0$. For a TtT call, L is the number of frames slipped on the satellite, either 0 or 1.

7.2.1.2 Synchronization in slave-to-master direction

In the slave-to-master direction, synchronization is based on the detection of error-free Golay coding bits. This procedure is outlined below:

- Slave Entity:

The PC transmit position is determined at call setup as follows:

- 1) During call setup, the slave entity shall determine and then maintain transmit PC message synchronization by selecting one of the six possible burst positions for the beginning of the PC messages.
- 2) This position shall be the earliest burst (modulo 6) that meets the following restriction: There shall be a guard time of at least T_{gt} ms between the expected completion of the last burst of the receive PC message to the beginning of the first burst of the transmit PC message. (Note that this determination is dependant on the timeslot assignments.)
- 3) The value of T_{gt} shall equal $T_p + 26$ ms, where T_p is the maximum allowed MES processing time for power control messages, such that there is no PC "message slip" between the reception of a PC message and the transmission of the response. The 26 ms is used as a margin to provide for MES-satellite relative motion. T_p shall be 132,8 msec worst case.
- 4) The MES shall send a PC message at the first timing opportunity to do so, independent of actual PC message reception from the master.

- Master entity:

Two correctly received PC messages are required to declare PC message synchronization, as follows:

- 1) For initial synchronization, the master entity shall continuously observe the most recent six bursts. It shall verify the 24 bits obtained as being a correct Golay message. The master entity shall re-encode the first 12 bits of the PC message, result is compared with the last 12 bits of the received PC message. Any single bit error shall cause declaration of message decoding error. This verification of the Golay message shall be performed every 40 ms, i.e., the 24-bit window is shifted by 4 bits each time. These comparison results are recorded on a per-burst basis (from 7 to 13 results, depending on channel conditions).
- 2) For initial synchronization, the master entity shall continuously examine the previously recorded results. It shall declare synchronization if it finds a sequence of $DDDDDD$ or $DDDDDXDDDD$ [where D corresponds to the detection of an error-free message, F corresponds to failure of detection, and X corresponds to a failure of detection at an expected D location].
- 3) Once in synchronization, Golay Decoding shall use this "D" position (modulo 6) as the current timing reference for end of the PC messages and shall decode and pass on the PC messages. This decoding shall be done even when the above sequences fail for this timing reference.
- 4) Re-sync: During a call, the master entity may continuously verify the status of synchronization as in Item 2, above. If the one of the expected patterns appears in a different timing position (modulo 6) than the current reference, then this new position is taken as the current timing reference - to be used for Item 3.

7.2.2 SACCH message synchronization, TCH6/TCH9 call

For SACCH message synchronization scheme, refer to GMR-1 05.003 [4].

8 Synchronization for TtT call

The TtT call in the GMR-1 network can be established in two different modes: single-hop mode and double-hop mode. The following clause addresses synchronization procedure in a single-hop TtT call. For a double-hop TtT call, synchronization procedure for each communication link is the same as that described for TtG/GtT call.

From a synchronization point of view, each MES involved in the TtT call performs a number of procedures. This is shown in figure 8.1.

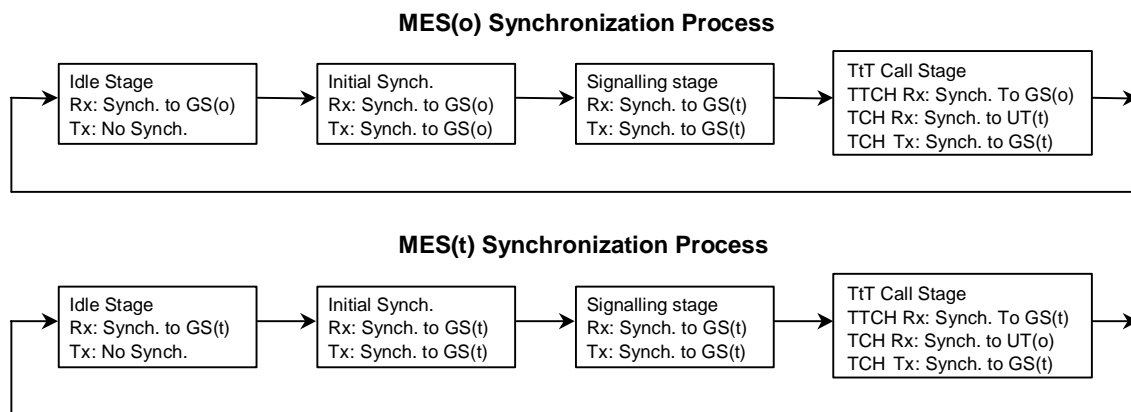

Figure 8.1: MES synchronization process for TtT Call

The general TtT call synchronization scenario is outlined below:

- In idle stage, both MESs synchronize their receivers to the BCCH signal (in frequency and timing) received from their registered GSs. For MES(o), the BCCH signal comes from the originating GS, denoted as GS(o). For MES(t), the BCCH signal comes from the terminating GS, denoted as GS(t).
- In the initial synchronization stage, the originating MES(o) performs a RACH procedure with the GS(o). The MES(o) is then synchronized with the GS(o) in both frequency and timing.
- In the signalling stage, the MES(o) corrects its transmission signal to GS(t) using frequency and timing corrections received from the GS(o) and starts its signalling transmission/reception with the GS(t) in the allocated TtG channel. MES(o)-GS(t) synchronization is achieved at this point.
- On the terminating side, after receive a paging message from the GS(t), the MES(t) performs another RACH procedure to synchronize its transmission with the GS(t). After that a TtG channel is assigned and signalling exchange can be performed between the MES(t) and the GS(t).
- During the signalling stage, frequency and timing synchronization follows the same scenario described for normal TtG call.
- At appropriate time, both MESs simultaneously switch from their TtG channels to the allocated TtT channels. Meanwhile, their transmission signals are corrected by timing and frequency corrections provided from the network. Terminal-to-terminal voice call starts from this point.
- During the TtT call, both TTCH and TCH signals are used by the MES as frequency and timing reference. In the downlink, the TTCH reception is used to control the terminal's perspective of timing and frequency. This reference is also used for voice transmission. In addition, the received TCH burst is separately tracked using offset relative to the TTCH-based observation. In the uplink, MES transmission is corrected by correction messages received from the TTCH channel.

As a result, there are two transition processes throughout a TtT call. One is transition from initial synchronization to signalling stage. The other is transition from signalling to TtT call stage. One task of synchronization is to provide smooth transition between different stages.

Two types of channels are involved for each terminal: TtG channel and TtT channel. The TtG channel is used by the MES for signalling exchange with the network, the TtT channel is used by the MES for voice message transmission/reception. Therefore another task of synchronization is to maintain timing and frequency synchronization accuracy in the usage of both channels.

Synchronization requirement addressed below takes the most general case as prototype, i.e., the two MESs are registered at two different GSs before a TtT call is initiated. The MES(o) is registered at GS(o), the MES(t) is registered at GS(t). Within the GS(t), two GSCs are involved during a call. The GSC(t1) is the GSC dealing with the MES(o) during the call, the GSC(t2) is the GSC dealing with the MES(t) during the call.

8.1 Timing synchronization

8.1.1 General description

The timing synchronization during a TtT call has several tasks: synchronization at initial access, synchronization of TtG channel, synchronization during the transition from TtG to TtT channel and synchronization of TtT channel.

Timing synchronization of the TtG channel: In the forward link, synchronization is performed at the MES by tracking signals received from the network. In the return link, the network keeps tracking signal arrivals transmitted from the MES, any transmission timing drift is then corrected by TC message received from the network.

Timing synchronization of the TtT channel: In the downlink, the MES maintains an independent tracking loop for both TtT signal and TTCH signal. In the uplink, TTCH-based observation is used as reference for transmission. Meanwhile, the network monitors signal arrivals transmitted from each MES, MES timing drift is then corrected by messages received from the TTCH.

The following symbolic definitions apply to the rest of the sections. T_{01} and T_{02} : propagation delay from the satellite to the originating beam centre and terminating beam centre, T_{U1} and T_{U2} : mobile link propagation delay seen from MES(o) and MES(t). K_{U1} and K_{D1} : uplink and downlink burst position allocated to MES(o), K_{U2} and K_{D2} : uplink and downlink burst position allocated to MES(t). The burst positions are all ranged from 0 to 23.

8.1.2 Initial access

To synchronize terminal transmission, each terminal performs a RACH procedure to the currently registered GS. After that, on the originating side, a timing correction message is provided from GS(o) to MES(o). On the terminating side, the timing correction is provided from GS(t) to MES(t). This is shown in figure 8.2.

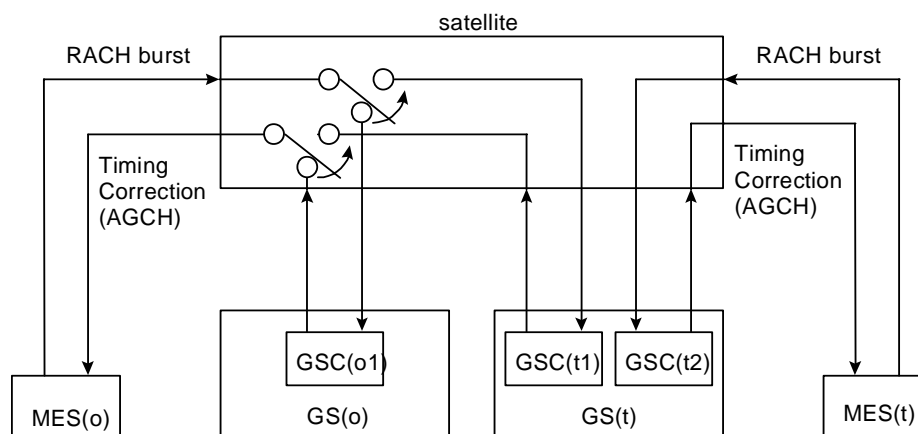

Figure 8.2: Initial timing synchronization for a TtT call

8.1.2.1 Synchronization procedure

The initial synchronization process for both MESs is outlined below.

- Before the TtT call, both MES(o) and MES(t) shall synchronize their receiver timing to the BCCH timing received from their registered GS. The MES(o) is synchronized to the BCCH timing received from GS(o), the MES(t) is synchronized to the BCCH timing received from GS(t).
- To synchronize MES transmitter with the system timing, the MES(o) shall send its RACH burst to the GS(o). Calculation of the RACH offset RACH_SYMBOL_OFFSET follows the same procedure introduced in 3.4.
- The GS(o) detects the MES(o)'s round trip differential delay $2[T_{U1} - T_{O1}]$ relative to the originating beam centre, and passes the value of Timing Offset to the MES(o) via the AGCH channel of the originating beam.
- The MES(o) shall switch its TX/RX frequency to the allocated TtG channel, offset its TCH transmission by, and start signalling exchange with the GSC(t1) of the GS(t). At this point, the MES(o) is known as synchronized with the GS(t) using timing information obtained from GS(o).
- Sometime later, the GSC(t2) of the GS(t) starts to page the MES(t). The MES(t) shall perform a similar RACH procedure and receive a timing correction factor $2[T_{U2} - T_{O2}]$ from the GSC(t2) via the AGCH channel of the terminating spot beam.
- The MES(t) shall switch its TX/RX frequency to the allocated TtG channel, offset its TCH transmission by $2[T_{U2} - T_{O2}]$, and start signalling exchange with the GSC(t2) of the GS(t). At this point, both MES(o) and MES(t) are known as synchronized with the GS(t).

After initial access, the frame offset between transmission frame N+7 and receive frame N at each MES is ΔT_{OF1} or ΔT_{OF2} , they are given as:

$$\begin{aligned}\Delta T_{OF1} &= \Delta T_{OFC1} - 2[T_{U1} - T_{O1}] \\ \Delta T_{OF2} &= \Delta T_{OFC2} - 2[T_{U2} - T_{O2}]\end{aligned}$$

ΔT_{OFC1} and ΔT_{OFC2} are frame offsets between transmission frame N+7 and receive frame N at originating and terminating beam centre, these information is broadcast over BCCH channel. For details, see clause 5.4.

8.1.2.2 Basic requirement

The GS shall be able to measure the RACH burst arrival to the accuracy better than $3,6 \mu\text{s}$ 1-sigma. After receiving the Timing Offset from the AGCH, the MES shall adjust its voice transmission timing to the accuracy better than $4,6 \mu\text{s}$ 1-sigma (with $1 \mu\text{s}$ quantization error) relative to system timing. The range and format of this Timing Offset message has been addressed in clause 5.4.2.

8.1.3 TtG channel synchronization

Two TtG channels are established for signalling message transmission at the beginning of a TtT call. One is between MES(o) and GSC(t1), the other is between MES(t) and GSC(t2). This is shown in figure 8.3.

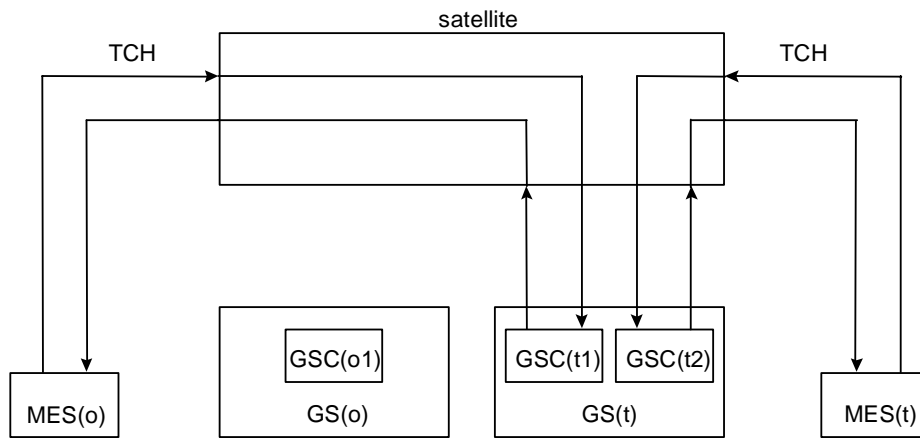

Figure 8.3: Signalling connections at the beginning of TtT call

Timing synchronization in the signalling stage is similar to that of normal TtG call. In case of a timing drift due to MES-satellite relative motion or MES master oscillator drift, both MESs shall compensate their receivers by tracking signals received in the downlink. In the uplink, transmission timing is corrected by TC messages received from the network. For MES(o), the TC message comes from GSC(t1). For MES(t), the TC message comes from GSC(t2). To perform smooth transition from TtG channel to TtT channel, a TC message shall be passed from the network to each MES before the L-to-L connection is activated.

8.1.3.1 Basic Requirement

The MES tracking loop shall be implemented to accommodate the worst case timing drift shown in clause 4.3.2. Meanwhile, the TCH channel based observation shall be used as timing reference for transmission. In the signalling stage, timing synchronization requires the same accuracy as that required for normal TtG call. The Timing Correction message shall have the same range and format as those described in clause 5.5.2.

8.1.4 Transition from TtG-to-TtT channel

After the signalling stage, both MESs switch from their corresponding TtG channels to the allocated TtT channels. From synchronization point of view, the transition stage has two major tasks: one is to setup a TtT link between the two MESs, the other is to setup a TTCH link for each MES. For MES(o), the TTCH in use is from GS(o). For MES(t), the TTCH in use is from GS(t). This is shown in figure 8.4.

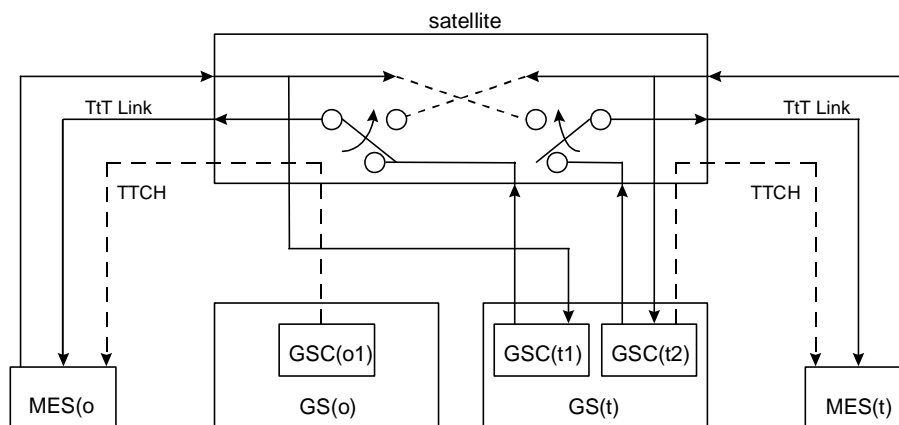

Figure 8.4: Two major tasks in the transition stage

8.1.4.1 Synchronization procedure

- A Timing Correction message is provided from the network to the MES via GtT channel. For MES(o), the TC factor is provided by the GSC(t1). For MES(t), the TC factor is provided by the GSC(t2).
- Each MES receiver uses the time base established from the GtT channel (signalling) observation as timing reference, switches to the allocated TtT channel and start their TtT message reception in the downlink.
- Each MES transmitter uses the time base established from the GtT channel (signalling) observation as timing reference, switches to the allocated TtT channels using the received TC factor as precorrection, and starts TtT message transmissions in the uplink.

8.1.4.2 Basic requirement

After transition stage, MES transmission timing error relative to system timing shall meet requirements defined in GMR-1 05.005 [5]. The Timing Correction message shall have the same range and format as those described in clause 5.5.2.

8.1.5 TtT channel synchronization

During the TtT call, the two terminals follow the same synchronization procedure. Various transmission paths are shown in figure 8.5.

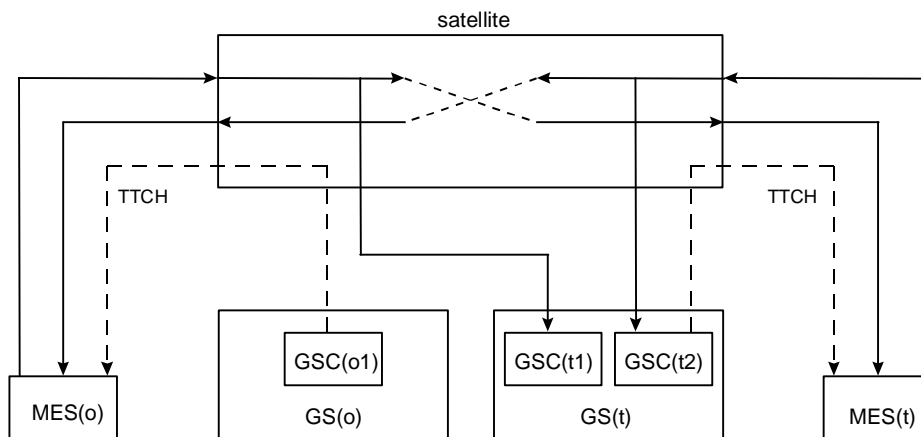

Figure 8.5: Transmission path during the TtT call

8.1.5.1 Synchronization procedure

In general, the MES timing reference is established using TTCH-based timing observation. This timing reference shall be used as TTCH reception and TCH signal transmission. A separate tracking loop shall be used to track the timing offset between TTCH signal and downlink TCH signal. In addition, any timing drift of terminal transmitter is corrected by Timing Correction messages received from the TTCH channel. The timing synchronization procedure during a TtT call is outlined below.

- Within each MES, a timing reference is established through TTCH channel observation. The MES keeps monitoring the timing of TTCH burst arrival, the derived TTCH timing shall be used to update the terminal's internal timebase. This timing reference shall be used by the MES for both TTCH signal receive and TCH signal transmission.
- For MES(o), the TTCH timing received from GS(o) shall be taken as its timing reference. For MES(t), the TTCH timing received from GS(t) shall be taken as its timing reference.
- To synchronize MES receiver with downlink TCH signal, a separate tracking loop shall be provided for downlink TCH signal observation. The TCH burst arrival is monitored and the derived timing shall be used to update the receive burst timing offset relative to its internal timebase.

- For transmission timing synchronization purpose, the terminal uplink signal is monitored by the network. In figure 8.5, the MES(o) transmission signal is monitored by GSC(t1), the MES(t) transmission signal is monitored by GSC(t2).
- On the network, the actual time of TCH burst arrival is monitored. If the timing error is found to be over 10 μ s, this error shall be passed to the MES as a TC message through its corresponding TTCH channel. The TC shall be made relative to the MES current transmission timing, same as that for normal TtG/GtT call described in clause 5.5.2. MES(o) receives the TC message from the TTCH transmitted from the GS(o), MES(t) receives the TC factor from the TTCH transmitted from the GS(t).
- After receiving the TC factor, the MES shall advance/retard its burst transmission by TC μ s and start transmission according to the new timing within 80 ms after reception of the TC message. This adjustment shall be made in the same way as that described in clause 5.5.2.

8.1.5.2 Basic requirement

Each MES shall time its burst transmission to the accuracy specified in GMR-1 05.005 [5]. The tracking loop of the MES receiver shall be implemented in such a way that performances for both TTCH and TCH demodulation specified in GMR-1 05.005 [5] can be achieved. A maximum timing drift rate specified in clause 4.3.2 shall be handled for both TTCH and TCH tracking loops. The TC message shall have the same range and format as those described in clause 5.5.2.

8.1.6 Effect of the half symbol offset (TtT call)

During the initial part of a TtT call when each party is talking to a GS, the half symbol offset operation is identical to the one described in clause 5.6.

When the reassignment is made to the L-to-L channel, the GS shall inform each MES involved in the call of the offset to be used on both the forward and return links. The GS shall assign both MESs with the same offset, so that the uplink channel offset used by each MES is the same as the downlink channel offset used by the peer MES.

The GS shall never offset the TTCH channel.

8.2 Frequency synchronization

8.2.1 General description

From frequency synchronization point of view, a number of procedures are involved during a TtT call.

- Prior to the TtT call, both MESs shall lock their receivers to the BCCH carriers received from their corresponding spot beams.
- To synchronize MES transmission frequency, both MESs perform a RACH procedure to synchronize with their registered GSs in frequency. The MES(o) is then synchronized with GS(o), the MES(t) is synchronized with GS(t).
- During signalling stage using TtG channel, the MES receiver tracks signals received from the GS(t). The derived frequency is used as reference for transmission. In the uplink, any transmission frequency drift is corrected by messages received from the network.
- During the TtT call using L-to-L link, independent tracking loops are provided for TtT signal and TTCH signal. In the uplink, TTCH-based observation is used as frequency reference for transmission. Meanwhile, the network monitors signal arrivals transmitted from each MES, MES frequency drift is then corrected by FC factors received from the TTCH.

The frequency synchronization during a TtT call has several tasks: synchronization at initial access, synchronization of TtG channel, synchronization during the transition from TtG-to-TtT channel and synchronization of TtT channel.

The following symbolic definitions apply to the rest of the sections. MES traffic channel TX/RX frequencies are F_T and F_R , the ratio between F_{RH} and F_B is $\varepsilon = F_{RH} / F_B \doteq F_T / F_R$, so that $F_{RH} = \varepsilon \cdot F_B$, $F_T \doteq \varepsilon \cdot F_R$, where \doteq represents approximately equal to. In the downlink, Doppler frequency at beam centre is dF_0 , Doppler received by the MES is dF_U . In the uplink, beam centre Doppler is $\varepsilon \cdot dF_0$, Doppler produced by the MES is $\varepsilon \cdot dF_U$.

8.2.2 Synchronization at initial access

The frequency compensation strategy at initial access is the same as that for normal TtG call. Both terminals involved in the TtT call shall align their RX/TX nominal frequencies on the satellite, this is shown in figure 8.6.

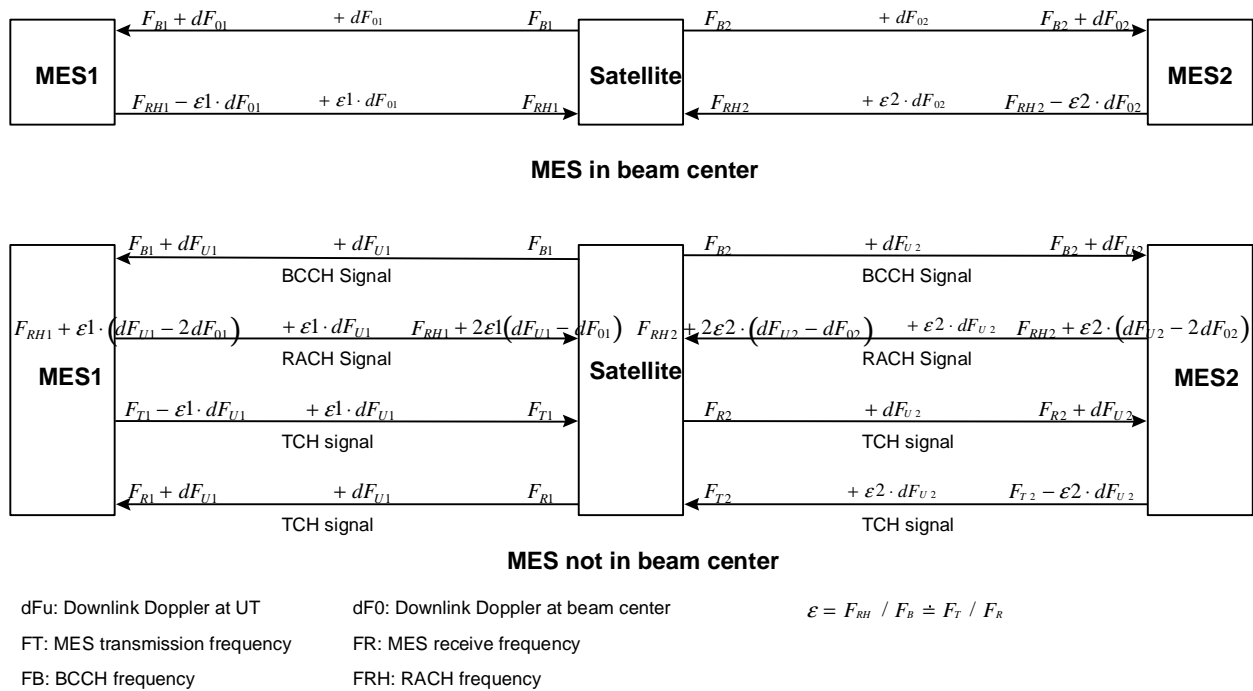

Figure 8.6: Doppler compensation scenario, TtT call

To synchronize terminal transmission frequency, each terminal performs a RACH procedure to the currently registered GS. After that, on the originating side, an FC factor is provided from GS(o) to MES(o). On the terminating side, a FC is provided from GS(t).

8.2.2.1 Synchronization procedure

The initial synchronization process for both MESs is outlined below.

- Before the TtT call, both MES(o) and MES(t) lock their receivers to the BCCH carrier received from their registered GS. The BCCH carrier used by MES(o) is received from the GS(o), the BCCH carrier used by MES(t) is received from GS(t).
- To synchronize MES transmitter in frequency, the MES(o) sends its RACH burst to the GS(o). The transmission frequency is generated using downlink BCCH frequency as reference, with $2 \cdot \varepsilon \cdot dF_{01}$ as pre-compensation. The value of $2 \cdot dF_{01}$ is twice the downlink beam centre Doppler due to satellite motion, it is received from the BCCH channel and has been detailed in clause 4.4. ε is the ratio between RACH frequency and BCCH frequency, and is calculated by the MES.
- The GS(o) detects the MES(o)'s round-trip differential Doppler $2\varepsilon[dF_{U1} - dF_{01}]$ relative to the originating beam centre, and passes this value to the MES(o) via the AGCH channel of the originating beam as FREQUENCY OFFSET. This message shall have the same range and format as those described in clause 4.4.2.

- The MES(o) uses downlink BCCH frequency F_{B1} as reference, switches its Tx/Rx frequencies to the allocated TtG channel, offsets its TCH transmission by the FREQUENCY OFFSET (approximately $2\epsilon[dF_{U1} - dF_{O1}]$), and starts signalling exchange with the GSC(t1) of the GS(t). At this point, the MES(o) is known as synchronized with the GS(t) in frequency using information obtained from GS(o).
- Sometime later, the GSC(t2) of the GS(t) starts to page the MES(t). The MES(t) performs a similar RACH procedure and receives a FREQUENCY OFFSET (approximately $2\epsilon \cdot [dF_{U2} - dF_{O2}]$) from the GSC(t2) via the AGCH channel of the terminating spot beam.
- The MES(t) uses downlink BCCH frequency F_{B2} as reference, switches its TX/RX frequencies to the allocated TtG channel, offsets its TCH transmission by the FREQUENCY OFFSET, and starts signalling exchange with the GSC(t2) of the GS(t).
- At this point, both MES(o) and MES(t) are known as synchronized with the GS(t) in frequency. On the satellite reference point, signal frequencies transmitted to both MESs are all nominal, signal frequencies received from both MESs are also nominal.

8.2.2.2 Basic requirement

After the RACH process, the MES shall adjust its transmission frequency to the accuracy better than 17,6 Hz 1-sigma (with 12,6 Hz RACH detection error and 5 Hz quantization error) relative to nominal frequency. This accuracy shall be met under the channel conditions specified in GMR-1 05.005 [5].

8.2.3 TtG channel synchronization

As was shown in figure 8.3, there are two TtG channels at signalling message transmission stage. One is between MES(o) and GSC(t1), the other is between MES(t) and GSC(t2).

Frequency synchronization scheme in the signalling stage is similar to that of normal TtG call. In case of any frequency drift due to a change of MES-satellite relative velocity or MES master oscillator drift, both MESs shall compensate their receivers by tracking the TCH signals received from the network. In the uplink, transmission frequency is corrected by FC messages received from the network. For MES(o), the FC message comes from GSC(t1). For MES(t), the FC message comes from GSC(t2). To perform smooth transition from TtG channel to TtT channel, a FC message shall be passed from the network to each MES before the L-to-L connection is activated.

8.2.3.1 Basic requirement

The MES tracking loop shall be implemented to accommodate the worst case frequency drift shown in clause 4.3.2. Meanwhile, the TCH channel based observation shall be used as frequency reference for transmission. In the signalling stage, frequency synchronization requires the same accuracy as that required for normal TtG call. The Frequency Correction message shall have the same range and format as those described in clause 6.4.2.

8.2.4 Transition from TtG-to-TtT channel

After the signalling stage, both MESs switch from their corresponding TtG channels to the allocated TtT channels. Again, from frequency synchronization point of view, the transition stage has two major tasks: one is to set up a TtT link between the two MESs, the other is to set up a TTCH link for each MES. For MES(o), the TTCH in use is from GS(o). For MES(t), the TTCH in use is from GS(t). This has been shown in figure 8.4.

8.2.4.1 Synchronization procedure

- A Frequency Correction message shall be provided from the network to the MES via GtT channel. For MES(o), the FC factor is provided by the GSC(t1). For MES(t), the FC factor is provided by the GSC(t2).
- Both MES receivers shall use their downlink GtT channel as frequency reference, switch to the allocated TtT channel and start their TtT message reception in the downlink.
- Both MES transmitters shall use their current TtG channel downlink frequency as reference, switch to the allocated TtT channels, use the received FC factors as precorrection, and start TtT message transmissions on the new channels.

8.2.4.2 Basic requirement

After the L-to-L cross link is activated, each of the two MES receivers is required to receive two signals, one is TCH signal, the other is TTCH signal. But the MES transmitter only transmits signals to the other MES. MES transmission frequency error shall be better than 15 Hz 1-sigma relative to nominal frequency, under channel conditions specified in GMR-1 05.005 [5]. The Frequency Correction message shall have the same range and format as those described in clause 6.4.2.

8.2.5 TtT channel synchronization

During a TtT call, the two terminals follow the same synchronization procedure. Various transmission paths have been shown in figure 8.5.

8.2.5.1 Synchronization procedure

In general, the MES frequency reference is established using TTCH-based frequency observation. This frequency reference shall be used as TTCH reception and TCH signal transmission. A separate tracking loop shall be used to track the frequency offset between TTCH signal and downlink TCH signal. In addition, any frequency drift of terminal transmitter shall be corrected by Frequency Correction (FC) messages received from the TTCH channel. The frequency synchronization procedure during a TtT call is outlined below.

- Within each MES, a frequency reference shall be established through TTCH channel observation. The MES keeps monitoring the frequency of TTCH burst arrival, the derived TTCH frequency shall be used to update the terminal's internal frequency reference. This reference shall be used by the MES for both TTCH signal receive and TCH signal transmission.
- For MES(o), the TTCH frequency received from GS(o) shall be taken as its frequency reference. For MES(t), the TTCH frequency received from GS(t) shall be taken as its frequency reference.
- To synchronize MES receiver with downlink TCH signal, a separate tracking loop shall be provided for downlink TCH signal observation. The TCH burst arrival is monitored and the derived frequency shall be used to update the TCH frequency offset relative to the TTCH-based frequency reference.
- For transmission frequency synchronization purpose, the terminal uplink signal is monitored by the network. In figure 8.5, the MES(o) transmission signal is monitored by GSC(t1), the MES(t) transmission signal is monitored by GSC(t2).

On the network, the actual frequency of TCH burst arrival is monitored. If the frequency error is found to be over a predefined threshold 40 Hz, this error shall be passed to the MES as a FC factor through its corresponding TTCH channel. MES(o) receives the FC factor from the TTCH transmitted from the GS(o), MES(t) receives the FC factor from the TTCH transmitted from the GS(t).

- After receiving the FC factor, the MES shall adjust its burst transmission by FC Hz and start transmission according to the new frequency within 80 ms after reception of the Frequency Correction message. This frequency adjustment shall be made in the same way as that described in clause 6.5.

8.2.5.2 Basic requirement

During a TtT call, the TTCH-based frequency observation shall be used as reference for TTCH reception and TCH transmission. Transmission frequency accuracy relative to nominal frequency shall meet requirement defined in GMR-1 05.005 [5]. The downlink TCH-based frequency observation shall be used as frequency reference for TCH signal reception. The MES receiver frequency error shall be small enough so that demodulation performances specified by GMR-1 05.005 [5] can be achieved. The Frequency Correction message shall have the same range and format as those described in clause 6.4.2.

8.3 Frame synchronization

The frame number variation on the satellite L-to-L connection is given as follows: Lot is the frame number variation for signal from MES(o) to MES(t), Lto is the frame number variation for signal from MES(t) to MES(o). The value of Lot and Lto is either 0 or 1. At the beginning of the call, the MES(t) shall be informed with the value of Lot, the MES(o) shall be informed with the value of Lto.

For ciphering purpose, the frame synchronization has two different stages for each MES. In the first stage, frame synchronization is established between each MES and the GS(t), the channel in use is GtT channel. In the second stage, frame synchronization is established between the two MESs, the channel in use is TtT channel.

Originating MES Side: MES(o)

The signalling message "Cipher Mode Command" stands for the beginning of ciphering process in the GtT channel. If the "Cipher Mode Command" is received in frame N, in the uplink, ciphering process shall be started beginning from frame N+9. In the downlink, deciphering process shall be started beginning from frame N+3. If a message is transmitted in frame K, the ciphering algorithm shall use frame number K. If a message is received from frame K, the deciphering algorithm shall also use frame number K.

The signalling message "Assignment Command 2" stands for the beginning of ciphering process in the TtT channel. If the "Assignment Command 2" is received in frame M, in the uplink, ciphering process to the TtT channel shall be started beginning from frame M+9. In the downlink, deciphering process from the TtT channel shall be started beginning from frame M+3. If a message is transmitted in frame K, the ciphering algorithm shall use frame number K. If a message is received in frame K, the deciphering algorithm shall use frame number K-Lto.

Terminating Side MES(t)

The signalling message "Cipher Mode Command" stands for the beginning of ciphering process in the GtT channel. If the "Cipher Mode Command" is received in frame N, in the uplink, ciphering process shall be started beginning from frame N+9. In the downlink, deciphering process shall be started beginning from frame N+3. If a message is transmitted in frame K, the ciphering algorithm shall use frame number K. If a message is received from frame K, the deciphering algorithm shall also use frame number K.

The signalling message "Assignment Command 2" stands for the beginning of ciphering process in the TtT channel. If the "Assignment Command 2" is received in frame M, in the uplink, ciphering process to the TtT channel shall be started beginning from frame M+9. In the downlink, deciphering process from the TtT channel shall be started beginning from frame M+3. If a message is transmitted in frame K, the ciphering algorithm shall use frame number K. If a message is received in frame K, the deciphering algorithm shall use frame number K-Lot.

9 Aeronautical terminal synchronization scheme

9.1 MES special features

9.1.1 Speed

Commercial aircraft fly at speeds less than about 1 000 km/hr. This is over six times the speed of vehicular-mounted terminals. The time required for an aircraft to completely turn about is typically 1 to 2 minutes. These characteristics imply timing, Doppler, and their rate-of-change as described in the following clauses.

9.1.2 Worst-case delay and doppler features

The following assumes that nominal frequency in the mobile uplink is 1,6605 GHz. In the mobile downlink, nominal frequency is 1,5590 GHz. The maximum user velocity is 1 000 km/hr, moving directly to the satellite. The time required for an aircraft to completely turn is 1 minute.

Time Delay Features

Item	Value
Maximum timing drift rate (user contribution)	1,11 μ s/sec
Maximum timing drift rate (satellite contribution)	0,17 μ s/sec
Maximum timing drift rate (total)	1,28 μ s/sec

Doppler Features, User Contribution

Item	Value
Maximum Doppler (uplink)	1,538 kHz
Maximum Doppler (downlink)	1,444 kHz
Maximum Doppler rate of change (uplink)	51 Hz/sec
Maximum Doppler rate of change (downlink)	48 Hz/sec

9.1.3 Frequency offset

Due to the large Doppler and rate-of-change of Doppler, the method used in ground-based terminals to measure and correct Doppler shall not suffice here. Therefore, extra effort shall be made in the aircraft to combat these effects. The principal method is to incorporate a higher stability frequency reference into the aircraft terminal that can be used to derive the absolute frequency offset the air terminal is experiencing and compensate for it in the return direction. The net effect shall be an aircraft terminal that emulates a slowly moving vehicular terminal. The degree of precision required shall be better than 10^{-7} . The long-term frequency drift of the oscillator shall be adjusted based on the standard frequency control loops in the existing infrastructure.

9.2 Frequency synchronization

9.2.1 Frequency synchronization general description

Due to the MES high speed and its variation, Doppler frequency can be very large and its rate of change can be much higher than that of a ground-based terminal. In the downlink, this results in the Doppler rate of change being out of the range which a ground-based terminal tracking loop can handle. In the uplink, the large Doppler variation results in frequent message correction from the network to the MES. For this reason, upgrade from a ground-based terminal shall be done in the following two aspects. First, an aeronautical terminal shall be equipped with a high stability frequency source from which nominal frequency can be derived with high accuracy. The MES shall use this source as its frequency reference for both transmission and receive. In addition, the MES shall be able to derive absolute Doppler frequency caused by MES-satellite relative motion. This is done by comparing the derived downlink carrier frequency with its nominal value. This Doppler frequency is then applied to MES transmitter so that MES transmission signal seen from the satellite is close to nominal.

The overall frequency error caused by MES oscillator and Doppler observation all together shall be better than 0,1 ppm.

9.2.2 Idle mode frequency synchronization

9.2.2.1 Initial frequency acquisition

At initial acquisition, the MES shall tune its receiver to the BCCH nominal frequencies based on its internal frequency reference. To acquire frequency synchronization to the selected control carrier, the MES frequency search range shall cover the range of frequency offset caused by aircraft motion ($\pm 1,5$ kHz) as well as frequency offset caused by satellite motion (± 264 Hz). After frequency acquisition, the MES receiver frequency accuracy relative to the received signal shall meet demodulation performances specified by GMR-1 05.005 [5].

9.2.2.2 Paging mode

In paging mode, the MES tunes its receiver to the frequency of downlink control carrier based on its internal frequency reference and control channel frequency offset. Similar to a ground-based terminal, to maintain synchronization, the control channel frequency offset is adjusted based on the standard tracking procedure. The MES receiver frequency tracking is based on either a PCH channel or a BCCH channel.

9.2.2.3 Alerting mode

In alerting mode, the MES again tunes its receiver to the frequency of downlink control carrier based on its internal frequency reference and control channel frequency offset. To maintain synchronization, the control channel frequency offset is adjusted based on the standard tracking procedure of the FCCH channel.

In both paging and alerting mode, the MES receiver frequency tracking loop needs to handle the worst-case Doppler frequency rate of change specified in clause 9.1.2. The tracking loop shall be implemented in such a way that demodulation performances specified in GMR-1 05.005 [5] can be achieved.

9.2.3 Synchronization at initial access

9.2.3.1 Frequency compensation strategy

The RACH process for an aeronautical MES differs from that of a ground-based terminal in such a way that prior to the RACH process, the MES already knows the Doppler frequency caused by MES-satellite relative motion. To send a RACH signal, the MES simply offsets its transmission by this Doppler value, then a nominal frequency can be expected on the satellite.

On the network side, an aeronautical terminal is treated in the same way as that for a ground-based terminal. The GS measures the frequency difference between the actual burst arrival and the expected arrival, a Frequency Correction message is then passed to the MES via AGCH channel. As the MES is equipped with an accurate frequency reference, and the uplink Doppler has already been compensated, the transmission of an aeronautical terminal always behaves like that from a stationary terminal, which is located close to spot beam centre.

The above description can be symbolically expressed as follows. If nominal RACH transmission frequency is F_{RH0} , nominal BCCH carrier frequency is F_{B0} , due to the Doppler effect, receive frequency measured by the MES is F_B (therefore Doppler frequency observed by the MES is $F_B - F_{B0}$). Then the MES shall adjust its RACH transmission to frequency F_{RH} , and

$$F_{RH} = F_{RH0} - \varepsilon(F_B - F_{B0})$$

After a Frequency Correction ΔF is received from the AGCH, the MES shall adjust its transmission so that transmission frequency becomes to be:

$$F_{RH} = F_{RH0} - \varepsilon(F_B - F_{B0}) - \Delta F$$

Since the MES internal reference and Doppler observation are both accurate enough, the value of this correction ΔF is always close to zero.

9.2.3.2 Parameter description

The aeronautical terminal shall achieve the same transmission and receive performances specified for ground-based terminal. After the RACH process, the MES transmission frequency error seen from the satellite shall be smaller than 17,6 Hz 1-sigma relative to nominal frequency.

The Frequency Correction message in the AGCH channel shall have the same format and step size as those described for ground-based terminal.

9.2.4 Dedicated mode synchronization

In call, both MES transmitter and receiver shall use its internal frequency source as reference. The uplink signal shall be corrected by downlink signal-based Doppler frequency observation. In addition, residual transmission frequency error is compensated further by correction messages received from the GS.

9.2.4.1 Frequency compensation strategy

In the downlink, the frequency tracking loop of the MES receiver shall be able to accommodate the large rate of frequency change caused by the variation of MES-satellite relative speed. The maximum rate of frequency change has been given in clause 9.1.2. Through this tracking procedure, the MES receiver shall be able to maintain its frequency accuracy relative to the received signal to meet the demodulation performances specified in GMR-1 05.005 [5].

In the uplink, the MES uses its internal frequency source as reference to decide the nominal transmission frequency. This frequency is then corrected by downlink signal based frequency offset observation. Assuming nominal MES transmission frequency is F_{T0} , nominal receive frequency is F_{R0} due to the Doppler effect, downlink receive frequency measured by the MES is F_R (therefore Doppler frequency observed by the MES is $F_R - F_{R0}$). Then the MES shall adjust its transmission to frequency F_T , and

$$F_T = F_{T0} - \varepsilon(F_R - F_{R0}).$$

During the call, downlink signal frequency is constantly monitored by the MES. If the frequency of the received signal changes from F_R to $F_R + \Delta F$, this change shall be immediately applied to its transmission, so that transmission frequency becomes to be:

$$F_T = F_{T0} - \varepsilon(F_R + \Delta F - F_{R0}).$$

Due to this adjustment, the MES shall achieve the same transmission performances specified for a ground-based terminal. As a result, from the network, the aeronautical terminal looks like a normal ground-based terminal in terms of its transmission frequency.

If the MES receiver frequency tracking loop cannot completely follow the frequency change of the downlink signal without any error, a frequency error shall be introduced to the uplink transmission signal. This remaining transmission frequency error shall be detected on the GS. A Frequency Correction message is then passed to the MES in the same way as that used for ground-based terminal. The MES shall use this message to update its voice or DKAB transmission frequency.

When the GS instructs an MES to switch from one channel to another (i.e., from SDCCH to TCH), a Frequency Correction message shall be provided to the MES. The MES then shall switch to the new channel and apply the received value to both of its transmitter and receiver.

9.2.4.2 Parameter description

In terms of frequency accuracy, an aeronautical terminal shall achieve the same transmission and receive performances specified for a ground-based terminal. The Frequency Correction message in the FACCH (TCH3) or SACCH (TCH6/TCH9) channel shall have the same format and step size as those described for a ground-based terminal.

9.3 Timing synchronization

9.3.1 Timing synchronization general description

Timing synchronization of an aeronautical terminal differs from that of a ground-based terminal in two different ways. First, due to the large timing drift rate caused by the aircraft motion, it is crucial to use Doppler frequency to estimate the timing drift rate. This timing drift rate shall be used to adjust both receive and transmission timing. In addition, due to the large timing drift rate, relative motion between uplink and downlink bursts at the reference point of an aeronautical MES is much faster than that of a ground-based terminal. This makes it very difficult to separate the RX/TX burst timing and to maintain enough guard time for all users throughout the call, especially for TCH6 and TCH9 calls. As a result, an aeronautical terminal shall be equipped with a duplexer, which allows simultaneous transmit and receive.

The MES shall calculate the current timing drift rate R based on the following if ΔF is the one-way Doppler frequency measured in the unit of Hz, F is the downlink signal nominal frequency measured in the unit of GHz. Then R shall be calculated as:

$$R = \frac{\Delta F}{F} (ns / sec)$$

For an aeronautical terminal moving with a speed up to 1 000 km/hr, the range of R can be up to $\pm 0,926 \mu s/sec$. The Doppler frequency shall be always calculated from the downlink signal based observation, i.e., the difference between downlink signal frequency measurement and nominal receive frequency. In idle mode (paging or alerting mode), the downlink signal refers to BCCH signal. During a call, the downlink signal refers to the voice signal.

The rest of the synchronization scheme is similar to that of a ground-based terminal. In idle mode, BCCH timing is used as MES timing reference, i.e., this timing is used to update MES internal time base. During a call, derived timing from the downlink signal (voice or DKAB) is used as reference for its transmission. In addition, to maintain synchronization, the MES transmission timing shall be corrected by the correction message received from the GS. RACH timing is still set up by messages provided over the BCCH. TCH or SDCCH timing is corrected by corrective messages given over the AGCH. In a call, timing the corrections is provided by FACCH (TCH3) or SACCH (TCH6/TCH9).

9.3.2 Idle mode timing synchronization

9.3.2.1 Initial timing acquisition

Same as ground-based terminal.

9.3.2.2 Paging mode

Same as ground-based terminal.

9.3.2.3 Alerting mode

Same as ground-based terminal.

In both paging and alerting mode, the downlink signal-based Doppler frequency observation shall be used to calculate MES timing drift rate. This timing drift rate is then used by the MES to adjust its internal time base in order to compensate MES-satellite relative motion. The timing drift rate shall be proportionally applied to the adjustment, once every T seconds. Then ΔT , the value of the adjustment each time is $\Delta T = T \cdot R$ ns.

9.3.3 Synchronization at initial access

At initial access, an aeronautical terminal uses the same RACH procedure as that described for ground-based terminal.

9.3.4 Dedicated mode synchronization

9.3.4.1 Doppler-based timing adjustment

In a call, both MES-receive and MES-transmission timing are adjusted by the Doppler based timing drift rate R . Each time the MES shall apply a fraction of R to the adjustment, the adjustment shall be made once every T seconds.

To align MES receiver with downlink signal in time, the MES internal timing reference shall be incremented by ΔT ns once every T seconds. Notice ΔT can be either position or negative; therefore, the adjustment can be made in both directions. Each time a change of frequency measurement of the received signal results in an update of the timing drift rate R . The new value of R (and therefore new value of ΔT) shall be applied to the MES timing reference in the next update period immediately following this change.

Since the MES transmission timing uses the received timing as reference, the transmission timing drift rate is doubled compared with the receive direction. To correct MES transmission timing, the adjustment shall be applied to the parameter ΔT_{OF} , the offset between uplink frame $N+7$ and downlink frame N , which has been defined before. If the MES RX timing reference is adjusted by ΔT ns once every T seconds, then ΔT_{OF} shall be adjusted by $2 \times \Delta T$ ns in the opposite direction, with T seconds as adjustment interval. This can be expressed as:

$$\Delta T_{OF} = \Delta T_{OF} - 2 \times \Delta T$$

9.3.4.2 Standard timing synchronization procedure

Through the Doppler-based timing adjustment procedure, the MES itself shall be able to compensate most of the timing drift without any correction received from the network. However, if the application of timing drift rate is still not enough to compensate all timing error (due to Doppler measurement error), the GS shall be able to correct the remaining timing error by providing a Timing Correction message through FACCH (TCH3) or SACCH (TCH6/TCH9) channel. This procedure is the same as that described for a ground-based terminal.

9.3.4.3 Parameter description

In terms of timing accuracy, an aeronautical terminal shall achieve the same transmission and receive performances specified for a ground-based terminal. The Timing Correction message in the FACCH (TCH3) or SACCH (TCH6/TCH9) channel shall have the same format and step size as those described for a ground-based terminal.

Annex A (informative): Worst-case delay and doppler features

In calculating the worst case delay and Doppler features, the following assumptions are taken into account:

The maximum satellite inclination angle is 6,7 degrees. Both time delay and satellite motion are approximately sinusoidal with a period of 24 hours. The worst-case user has an elevation of 20 degree when the satellite is on equator.

The maximum user velocity is 160 km/hr, moving directly to the satellite. For accelerating user, its velocity is increased from 0 to 160 km/hr in 10 seconds.

In the mobile uplink, nominal frequency is 1,6605 GHz. In the mobile downlink, nominal frequency is 1,5590 GHz.

Table A.1: Time delay features

Item	Value
Minimum Delay	129,66 ms
Maximum Delay	134,33 ms
Maximum Rate of Delay Change (satellite contribution)	0,1696 μ s/sec
Maximum rate of delay change (user contribution)	0,1482 μ s/sec
Maximum rate of delay change (overall value)	0,3178 μ s/sec

Table A.2: Doppler features, satellite contribution

Item	Value
Maximum Doppler (uplink)	282 Hz
Maximum Doppler (downlink)	264 Hz
Maximum Doppler rate of change (uplink)	0,0204 Hz/sec
Maximum Doppler rate of change (downlink)	0,0192 Hz/sec

Table A.3: Doppler features, user contribution

Item	Value
Maximum Doppler (uplink)	246 Hz
Maximum Doppler (downlink)	231 Hz
Maximum Doppler rate of change (uplink)	24,6 Hz/sec
Max. Doppler rate of change (Downlink)	23,1 Hz/sec

Table A.4: Doppler features, overall values

Item	Value
Maximum Doppler (uplink)	528 Hz
Maximum Doppler (downlink)	495 Hz
Maximum Doppler rate of change (uplink)	24,6 Hz/sec
Maximum Doppler rate of change (downlink)	23,1 Hz/sec

Annex B (informative): Range of timing correction factor

The maximum round-trip differential delay relative to beam centre $2[T_U - T_0]$ is calculated for 0,7 degree nominal beam angle and 50% beam angle extension. Calculation results are given in figure B.1 under various elevation angles seen from the furthest corner of the spot beam. From this graph, the value of $2[T_U - T_0]$ varies from 0 to 9,73 ms.

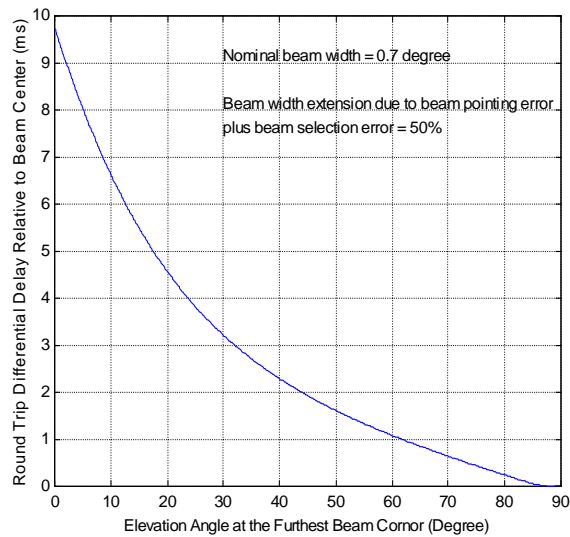

Figure B.1: Maximum round-trip differential delay within spot beams

Annex C (informative): Differential doppler frequency

The maximum beam differential Doppler frequency relative to beam centre for a stationary MES located on the beam edge is calculated for various spot beam elevation angles, result is given in figure C.1. From this graph, the differential Doppler is less than ± 11 Hz worst case.

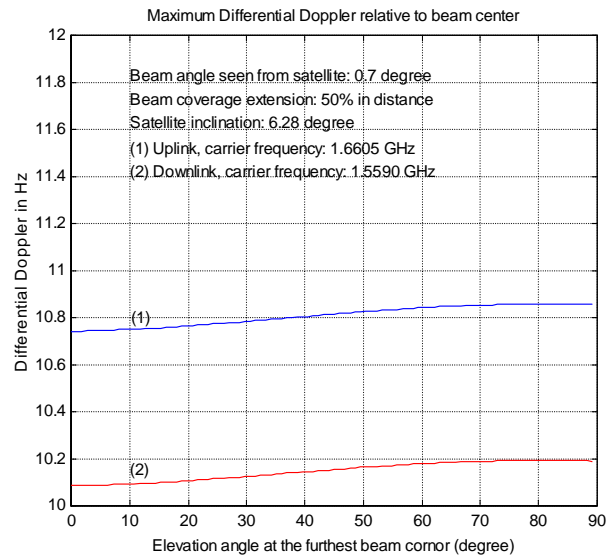

Figure C.1: Maximum differential doppler, stationary MES on beam edge

Annex D (informative): SACCH message synchronization, TtG/GtT call

Baseline design: The MES uses a fixed SACCH message transmission frame offset relative to the frame number of the received SACCH message. One SACCH frame offset shall be applicable to all users in the system.

D.1 SACCH message synchronization scenario

With a single frame offset, the available MES processing time between message receive and transmission depends on MES position and burst position. Two extremes are considered: The smallest processing time and the largest processing time.

The smallest processing time: MES with the lowest elevation, forward link burst in position 23, 0, 1, return link burst position in 0, 1, 2. For minimum processing time = 120 ms, first TX frame = N+11. See figure D.1.

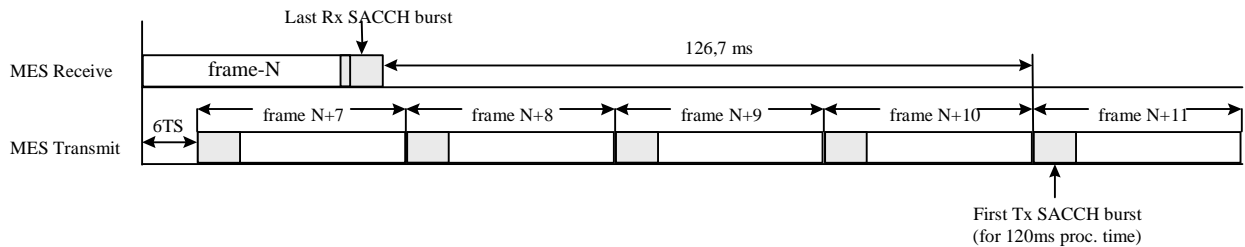

Figure D.1: The Worst-case available at processing time, MES with the lowest elevation, for SACCH message

The largest processing time: MES on subsatellite point, forward link burst in position 0, 1, 2, return link burst position in 23, 0, 1. For minimum processing time = 120 ms, TX frame number = N+11, there is a maximum 240 ms processing interval. This is the penalty of the SACCH transmission algorithm. See figure D.2.

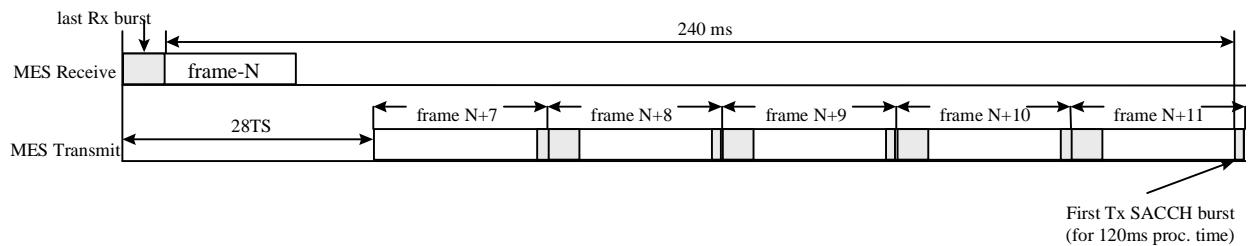

Figure D.2: The longest available MES processing time, MES on subsatellite point, for SACCH message

D.2 SACCH message-round trip delay

The round-trip SACCH message delay is defined to be the interval from the beginning of the first SACCH message burst transmitted from the network to the arrival of the last response burst received from the MES. See figure D.3.

T_N : feeder link delay; T_U : service link delay, dT : interval between the last received frame (frame N) and the first transmitted frame (frame N+11) at the position of MES.

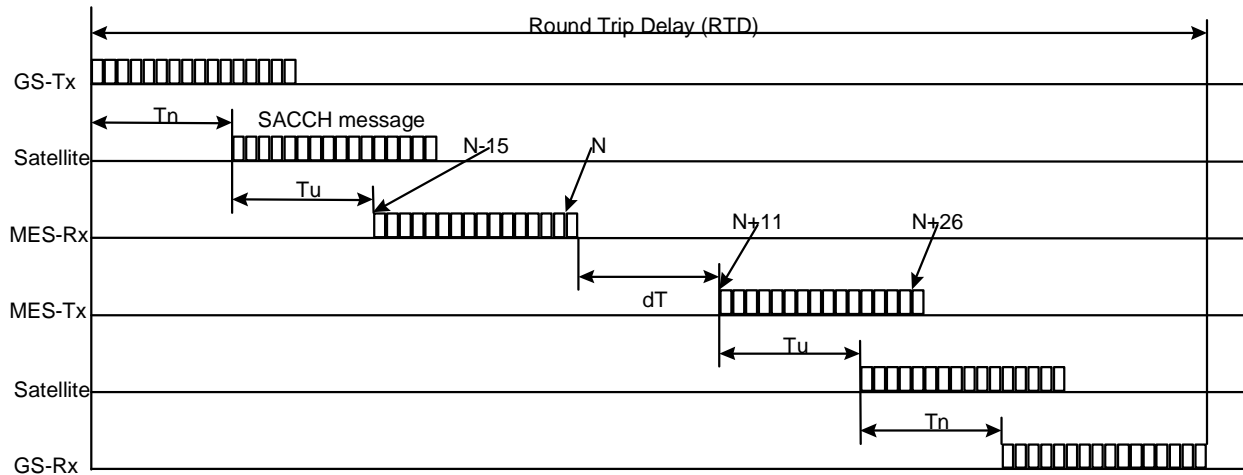

Figure D.3: Timing relationship for SACCH message round-trip transmission

Interval dT :

$$dT = 10T_F - 2T_U$$

RTD calculation, assuming satellite delay is zero:

$$\begin{aligned} RTD &= 32T_F + 2T_N + 2T_U + dT - K_D T_S - (T_F - K_U T_S - T_{CH}) \\ &= 41T_F + 2T_N + (K_U - K_D + X)T_S \end{aligned}$$

For TCH6, X = 6. For TCH9, X = 9. Let

$$W = 2T_N + (K_U - K_D)T_S$$

then

$$RTD = 41T_F + W + X \cdot T_S$$

and

$$\begin{aligned} W_{\min} &\leq W \leq W_{\max} \\ W_{\min} &= 2T_{N \min} - 23T_S \\ W_{\max} &= 2T_{N \max} + 23T_S \end{aligned}$$

The RTD is calculated as a function of W, results are given in figure D.4.

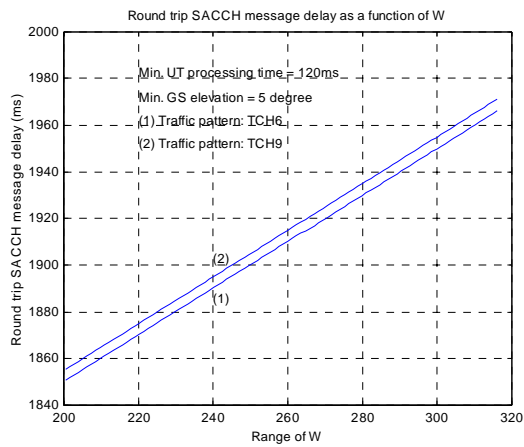

Figure D.4: Round-trip SACCH message transmission delay (ms)

From this graph, the earliest response message takes about 1 850 ms to arrive at the GS, the latest response message takes about 1 970 ms to arrive at the GS. This is shown in figure D.5.

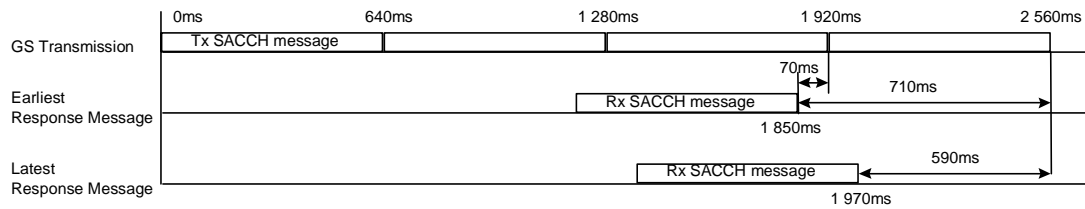

Figure D.5: SACCH message transmission/reception at the GS

History

Document history		
V1.1.1	March 2001	Publication