

# ETSI TS 101 376-4-7 V3.2.1 (2011-02)

---

*Technical Specification*

**GEO-Mobile Radio Interface Specifications (Release 3);  
Third Generation Satellite Packet Radio Service;  
Part 4: Radio interface protocol specifications;  
Sub-part 7: Mobile Radio Interface Signalling Layer 3  
General Aspects;  
GMR-1 3G 24.007**

---



---

Reference

RTS/SES-00315-4-7

---

Keywords

GMPRS, GMR, GPRS, GSM, GSO, interface,  
layer3, MES, mobile, MSS, radio, satellite,  
signalling, S-PCN

**ETSI**

650 Route des Lucioles  
F-06921 Sophia Antipolis Cedex - FRANCE

Tel.: +33 4 92 94 42 00 Fax: +33 4 93 65 47 16

Siret N° 348 623 562 00017 - NAF 742 C  
Association à but non lucratif enregistrée à la  
Sous-Préfecture de Grasse (06) N° 7803/88

---

**Important notice**

Individual copies of the present document can be downloaded from:

<http://www.etsi.org>

The present document may be made available in more than one electronic version or in print. In any case of existing or perceived difference in contents between such versions, the reference version is the Portable Document Format (PDF). In case of dispute, the reference shall be the printing on ETSI printers of the PDF version kept on a specific network drive within ETSI Secretariat.

Users of the present document should be aware that the document may be subject to revision or change of status. Information on the current status of this and other ETSI documents is available at

<http://portal.etsi.org/tb/status/status.asp>

If you find errors in the present document, please send your comment to one of the following services:

[http://portal.etsi.org/chaicor/ETSI\\_support.asp](http://portal.etsi.org/chaicor/ETSI_support.asp)

---

**Copyright Notification**

No part may be reproduced except as authorized by written permission.  
The copyright and the foregoing restriction extend to reproduction in all media.

© European Telecommunications Standards Institute 2011.  
All rights reserved.

**DECT™**, **PLUGTESTS™**, **UMTS™**, **TIPHON™**, the TIPHON logo and the ETSI logo are Trade Marks of ETSI registered for the benefit of its Members.

**3GPP™** is a Trade Mark of ETSI registered for the benefit of its Members and of the 3GPP Organizational Partners.

**LTE™** is a Trade Mark of ETSI currently being registered

for the benefit of its Members and of the 3GPP Organizational Partners.

**GSM®** and the GSM logo are Trade Marks registered and owned by the GSM Association.

# Contents

Intellectual Property Rights .....	5
Foreword.....	5
Introduction .....	6
1 Scope .....	8
2 References .....	8
2.1 Normative references .....	8
2.2 Informative references.....	9
3 Definitions and abbreviations.....	9
3.1 Definitions .....	9
3.2 Abbreviations .....	9
4 Introduction .....	9
4.1 General .....	9
4.2 Applicability of functional blocks .....	10
4.3 Technique of description .....	10
4.3.1 Service description.....	10
4.3.2 Abstract service primitives .....	10
4.3.3 Protocols and peer-to-peer communication .....	10
4.3.4 Contents of layer 3 related Technical Specifications .....	10
5 Structure of layer 3 functions .....	10
5.1 Basic groups of functions .....	10
5.2 Protocol architecture.....	11
6 Services provided by signalling layer 3 at the MS side.....	11
6.1 Registration services.....	12
6.2 Call Control services .....	12
6.3 Call-independent supplementary services support .....	12
6.4 Short Message Services support.....	12
6.5 MN-RR state services support.....	12
6.6 Position information support .....	12
6.7 DTMF digits transmission and reception service .....	12
6.8 Session Management Services for GMPRS-Services.....	12
6.9 Registration Services for GMPRS-Services .....	12
6.10 Services provided to SMDCP entities by GMPRS Logical Link Control services .....	12
6.11 Dark-beam information support .....	12
7 Services provided by signalling layer 3 on the Network side .....	13
7.1 Call Control services .....	13
7.2 Call-independent supplementary services support .....	13
7.3 Short Message Services support.....	13
7.4 Services provided to SMDCP and SMS entities by GMPRS Logical Link Control services .....	13
7.5 Session Management services for GMPRS-1 .....	13
8 Services assumed from signalling layers 1 and 2.....	13
9 Interlayer service interfaces on the MMS side .....	13
9.1 Services provided by the Radio Resource management entity .....	13
9.1.1 Service state diagram.....	13
9.1.2 Service primitives .....	13
9.2 Services provided by the Mobility Management entity.....	13
9.2.1 Service state diagram.....	14
9.2.2 Service primitives .....	14
9.3 Services provided by radio resource management entity for GMPRS services .....	14
9.3.1 Service primitives for GRR-SAP (A/Gb mode only) .....	14
9.3.2 Service primitives for GMMRR-SAP (A/Gb mode only) .....	14

9.3.3	Service primitives for RABMAS-SAP (Iu mode only) .....	14
9.3.4	Service primitives for GMMAS-SAP (Iu mode only) .....	14
9.4	Services provided by LLC entity for GMPRS services (A/Gb mode only).....	14
9.5	Registration Services provided for GMPRS services .....	14
9.5.1	Service primitives for GMMSM-SAP .....	14
9.5.2	Void .....	14
9.5.3	Service primitives for GMMSMS-SAP .....	14
9.5.4	Service primitives for PMMSMS-SAP (Iu mode only).....	14
9.5.5	Service primitives for GMMRABM-SAP (Iu mode only).....	15
10	Interlayer service interfaces on the Network side .....	15
11	Standard layer 3 messages.....	15
11.1	Components of a standard layer 3 message.....	15
11.2	Imperative part of a standard layer 3 message.....	15
11.2.1	Protocol discriminator.....	15
11.2.2	Skip Indicator.....	15
11.2.3	Transaction identifier.....	15
11.2.4	Message type .....	15
11.2.5	Further information elements of the imperative part .....	15
11.3	Non-imperative part of a standard layer 3 message.....	15
11.4	Presence requirements of information elements.....	15
11.5	Handling of superfluous information .....	16
11.5.1	Information elements that are unnecessary in a message.....	16
<b>Annex A (informative):</b>	<b>MN-Services arrow diagram.....</b>	<b>17</b>
<b>Annex B (informative):</b>	<b>Description of CSN.1 .....</b>	<b>18</b>
<b>Annex C (informative):</b>	<b>GPRS-Services sequence diagram.....</b>	<b>19</b>
History .....		20

---

# Intellectual Property Rights

IPRs essential or potentially essential to the present document may have been declared to ETSI. The information pertaining to these essential IPRs, if any, is publicly available for **ETSI members and non-members**, and can be found in ETSI SR 000 314: *"Intellectual Property Rights (IPRs); Essential, or potentially Essential, IPRs notified to ETSI in respect of ETSI standards"*, which is available from the ETSI Secretariat. Latest updates are available on the ETSI Web server (<http://webapp.etsi.org/IPR/home.asp>).

Pursuant to the ETSI IPR Policy, no investigation, including IPR searches, has been carried out by ETSI. No guarantee can be given as to the existence of other IPRs not referenced in ETSI SR 000 314 (or the updates on the ETSI Web server) which are, or may be, or may become, essential to the present document.

---

## Foreword

This Technical Specification (TS) has been produced by ETSI Technical Committee Satellite Earth Stations and Systems (SES).

The contents of the present document are subject to continuing work within TC-SES and may change following formal TC-SES approval. Should TC-SES modify the contents of the present document it will then be republished by ETSI with an identifying change of release date and an increase in version number as follows:

Version 3.m.n

where:

- the third digit (n) is incremented when editorial only changes have been incorporated in the specification;
- the second digit (m) is incremented for all other types of changes, i.e. technical enhancements, corrections, updates, etc.

The present document is part 4, sub-part 7 of a multi-part deliverable covering the GEO-Mobile Radio Interface Specifications (Release 3) Third Generation Satellite Packet Radio Service, as identified below:

Part 1: "General specifications";

Part 2: "Service specifications";

Part 3: "Network specifications";

**Part 4: "Radio interface protocol specifications":**

Sub-part 1: "Mobile Earth Station-Gateway Station System (MES-GSS) Interface";

Sub-part 2: "GMR-1 Satellite Network Access Reference Configuration";

Sub-part 3: "Channel Structures and Access Capabilities";

Sub-part 4: "Layer 1 General Requirements";

Sub-part 5: "Data Link Layer General Aspects";

Sub-part 6: "Mobile earth Station-Gateway Station Interface Data Link Layer Specifications";

**Sub-part 7: "Mobile Radio Interface Signalling Layer 3 General Aspects";**

Sub-part 8: "Mobile Radio Interface Layer 3 Specifications";

Sub-part 9: "Performance Requirements on the Mobile Radio Interface";

Sub-part 10: "Rate Adaptation on the Access Terminal-Gateway Station Subsystem (MES-GSS) Interface";

Sub-part 11: "Radio Link Protocol (RLP) for Data Services";

- Sub-part 12: "Mobile Earth Station (MES) - Base Station System (BSS) interface; Radio Link Control/Medium Access Control (RLC/MAC) protocol";
- Sub-part 13: "Radio Resource Control (RRC) protocol; Iu Mode";
- Sub-part 14: "Mobile Earth Station (MES) - Base Station System (BSS) interface; Radio Link Control/Medium Access Control (RLC/MAC) protocol; Iu Mode";
- Part 5: "Radio interface physical layer specifications";
- Part 6: "Speech coding specifications";
- Part 7: "Terminal adaptor specifications".

---

## Introduction

GMR stands for GEO (Geostationary Earth Orbit) Mobile Radio interface, which is used for Mobile Satellite Services (MSS) utilizing geostationary satellite(s). GMR is derived from the terrestrial digital cellular standard GSM and supports access to GSM core networks.

The present document is part of the GMR Release 3 specifications. Release 3 specifications are identified in the title and can also be identified by the version number:

- Release 1 specifications have a GMR 1 prefix in the title and a version number starting with "1" (V1.x.x).
- Release 2 specifications have a GMPRS 1 prefix in the title and a version number starting with "2" (V2.x.x).
- Release 3 specifications have a GMR-1 3G prefix in the title and a version number starting with "3" (V3.x.x).

The GMR release 1 specifications introduce the GEO Mobile Radio interface specifications for circuit mode Mobile Satellite Services (MSS) utilizing geostationary satellite(s). GMR release 1 is derived from the terrestrial digital cellular standard GSM (phase 2) and it supports access to GSM core networks.

The GMR release 2 specifications add packet mode services to GMR release 1. The GMR release 2 specifications introduce the GEO Mobile Packet Radio Service (GMPRS). GMPRS is derived from the terrestrial digital cellular standard GPRS (included in GSM Phase 2+) and it supports access to GSM/GPRS core networks.

The GMR release 3 specifications evolve packet mode services of GMR release 2 to 3rd generation UMTS compatible services. The GMR release 3 specifications introduce the GEO-Mobile Radio Third Generation (GMR-1 3G) service. Where applicable, GMR-1 3G is derived from the terrestrial digital cellular standard 3GPP and it supports access to 3GPP core networks.

Due to the differences between terrestrial and satellite channels, some modifications to the GSM or 3GPP standard are necessary. Some GSM and 3GPP specifications are directly applicable, whereas others are applicable with modifications. Similarly, some GSM and 3GPP specifications do not apply, while some GMR specifications have no corresponding GSM or 3GPP specification.

Since GMR is derived from GSM and 3GPP, the organization of the GMR specifications closely follows that of GSM or 3GPP as appropriate. The GMR numbers have been designed to correspond to the GSM and 3GPP numbering system. All GMR specifications are allocated a unique GMR number. This GMR number has a different prefix for Release 2 and Release 3 specifications as follows:

- Release 1: GMR n xx.zyy.
- Release 2: GMPRS n xx.zyy.
- Release 3: GMR-1 3G xx.zyy.

where:

xx.0yy (z = 0) is used for GMR specifications that have a corresponding GSM or 3GPP specification. In this case, the numbers xx and yy correspond to the GSM or 3GPP numbering scheme.

xx.2yy ( $z = 2$ ) is used for GMR specifications that do not correspond to a GSM or 3GPP specification. In this case, only the number xx corresponds to the GSM or 3GPP numbering scheme and the number yy is allocated by GMR.

n denotes the first ( $n = 1$ ) or second ( $n = 2$ ) family of GMR specifications.

A GMR system is defined by the combination of a family of GMR specifications and GSM and 3GPP specifications as follows:

- If a GMR specification exists it takes precedence over the corresponding GSM or 3GPP specification (if any). This precedence rule applies to any references in the corresponding GSM or 3GPP specifications.

NOTE: Any references to GSM or 3GPP specifications within the GMR or 3GPP specifications are not subject to this precedence rule. For example, a GMR or 3GPP specification may contain specific references to the corresponding GSM or 3GPP specification.

- If a GMR specification does not exist, the corresponding GSM or 3GPP specification may or may not apply. The applicability of the GSM or 3GPP specifications is defined in GMR-1 3G 1 41.201 [2].

The clause numbering and the table numbering and figure numbering in the present document are aligned to the corresponding numbering of GMR-1 04.007 [4] as far as possible.

---

# 1 Scope

The present document defines the architecture of Layer 3 and its sublayers on the GeoMobile (GMR-1) Air Interface. Most of the procedures defined for Layer 3 are similar to those defined in 3GPP system as defined in 3GPP TS 24.007 [5]. Only significant differences are described here.

---

# 2 References

References are either specific (identified by date of publication and/or edition number or version number) or non-specific. For specific references, only the cited version applies. For non-specific references, the latest version of the reference document (including any amendments) applies.

Referenced documents which are not found to be publicly available in the expected location might be found at <http://docbox.etsi.org/Reference>.

NOTE: While any hyperlinks included in this clause were valid at the time of publication ETSI cannot guarantee their long term validity.

## 2.1 Normative references

The following referenced documents are necessary for the application of the present document.

In the case of a reference to a 3GPP document (including a GSM document), a non-specific reference implicitly refers to the latest version of that document *in the same Release as the present document*.

- [1] GMPRS-1 01.004 (ETSI TS 101 376-1-1): "GEO-Mobile Radio Interface Specifications (Release 2); General Packet Radio Service; Part 1: General specifications; Sub-part 1: Abbreviations and acronyms".

NOTE: This is a reference to a GMR-1 Release 2 specification. See the introduction for more details.

- [2] GMR-1 3G 41.201 (ETSI TS 101 376-1-2): "GEO-Mobile Radio Interface Specifications (Release 3) Third Generation Satellite Packet Radio Service; Part 1: General specifications; Sub-part 2: Introduction to the GMR-1 family".

- [3] GMPRS-1 04.007 (ETSI TS 101 376-4-7): "GEO-Mobile Radio Interface Specifications (Release 2) General Packet Radio Service (GMPRS); Part 4: Radio interface protocol specifications; Sub-part 7: Mobile Radio Interface Signalling Layer 3 General Aspects".

NOTE: This is a reference to a GMR-1 Release 2 specification. See the introduction for more details.

- [4] GMR-1 3G 44.008 (ETSI TS 101 376-4-8): "GEO-Mobile Radio Interface Specifications (Release 3); Third Generation Satellite Packet Radio Service; Part 4: Radio interface protocol specifications; Sub-part 8: Mobile Radio Interface Layer 3 Specifications".

- [5] 3GPP TS 24.007 (ETSI TS 124 007): "3<sup>rd</sup> Generation Partnership Project; Technical Specification Group Core Network and Terminals; Mobile radio interface signalling layer 3; General aspects".

- [6] 3GPP TS 24.008 (ETSI TS 124 008): "3<sup>rd</sup> Generation Partnership Project; Technical Specification Group Core Network and Terminals; Mobile radio interface Layer 3 specification Core Network Protocols-Stage 3".

- [7] 3GPP TS 24.010 (ETSI TS 124 010): "3<sup>rd</sup> Generation Partnership Project; Technical Specification Group Core Network and Terminals; Mobile radio interface Layer 3; Supplementary services specification; General aspects".

- [8] 3GPP TS 24.011 (ETSI TS 124 011): "3<sup>rd</sup> Generation Partnership Project; Technical Specification Group Core Network and Terminals; Point-to-Point (PP) Short Message Service (SMS) support on mobile radio interface".



- [9] 3GPP TS 24.080 (ETSI TS 124 080): "3<sup>rd</sup> Generation Partnership Project; Technical Specification Group Core Network and Terminals; Mobile radio Layer 3 supplementary services specification; Formats and coding".
- [10] 3GPP TS 24.081 (ETSI TS 124 081): "3<sup>rd</sup> Generation Partnership Project; Technical Specification Group Core Network and Terminals; Line identification supplementary services; Stage 3".
- [11] 3GPP TS 24.082 (ETSI TS 124 082): "3<sup>rd</sup> Generation Partnership Project; Technical Specification Group Core Network and Terminals; Call Forwarding (CF) supplementary services - Stage 3".
- [12] 3GPP TS 24.083 (ETSI TS 124 083): "3<sup>rd</sup> Generation Partnership Project; Technical Specification Group Core Network and Terminals; Call Waiting (CW) and Call Hold (HOLD) supplementary services; Stage 3".
- [13] 3GPP TS 24.084 (ETSI TS 124 084): "3<sup>rd</sup> Generation Partnership Project; Technical Specification Group Core Network and Terminals; MultiParty (MPTY) supplementary services; Stage 3".
- [14] 3GPP TS 24.085 (ETSI TS 124 085): "3<sup>rd</sup> Generation Partnership Project; Technical Specification Group Core Network and Terminals; Closed User Group (CUG) supplementary services; Stage 3".
- [15] 3GPP TS 24.086 (ETSI TS 124 086): "3<sup>rd</sup> Generation Partnership Project; Technical Specification Group Core Network and Terminals; Advice of Charge (AoC) supplementary services; Stage 3".
- [16] 3GPP TS 24.088 (ETSI TS 124 088): "3<sup>rd</sup> Generation Partnership Project; Technical Specification Group Core Network and Terminals; Call Barring (CB) supplementary services; Stage 3".
- [17] 3GPP TS 24.090 (ETSI TS 124 090): "3<sup>rd</sup> Generation Partnership Project; Technical Specification Group Core Network and Terminals; Unstructured Supplementary Service Data (USSD) - Stage 3".
- [18] 3GPP TS 24.030 (ETSI TS 124 030): "3<sup>rd</sup> Generation Partnership Project; Technical Specification Group Core Network and Terminals; Location Services (LCS); Supplementary service operations - Stage 3".

## 2.2 Informative references

The following referenced documents are not necessary for the application of the present document but they assist the user with regard to a particular subject area.

Not applicable.

---

## 3 Definitions and abbreviations

### 3.1 Definitions

For the purposes of the present document, the terms and definitions given in GMR-1 3G 41.201 [2] apply.

### 3.2 Abbreviations

For the purposes of the present document, the abbreviations given in GMPRS-1 01.004 [1] apply.

---

## 4 Introduction

### 4.1 General

Same as clause 4.1 of GMPRS-1 04.007 [3].

## 4.2 Applicability of functional blocks

Same as clause 4.2 of GMPRS-1 04.007 [3].

## 4.3 Technique of description

Same as clause 4.3 of GMPRS-1 04.007 [3].

### 4.3.1 Service description

Same as clause 4.3.1 of GMPRS-1 04.007 [3].

### 4.3.2 Abstract service primitives

Same as clause 4.3.2 of GMPRS-1 04.007 [3].

### 4.3.3 Protocols and peer-to-peer communication

Same as clause 4.3.3 of GMPRS-1 04.007 [3].

### 4.3.4 Contents of layer 3 related Technical Specifications

- The Radio Resource (RR) management protocol is defined in GMR-1 3G 44.008 [4];
- the Mobility Management (MM) protocol is defined in 3GPP TS 24.008 [6];
- the Session Management (SM) protocol is defined in 3GPP TS 24.008 [6];
- the Call Control (CC) protocol is defined in 3GPP TS 24.008 [6];
- the Supplementary Services (SS) protocol is defined in 3GPP TS 24.010 [7], 3GPP TS 24.080 [9]; 3GPP TS 24.081 [10], 3GPP TS 24.082 [11], 3GPP TS 24.083 [12], 3GPP TS 24.084 [13], 3GPP TS 24.085 [14], 3GPP TS 24.086 [15], 3GPP TS 24.088 [16], 3GPP TS 24.090 [17] and 3GPP TS 24.030 [18];
- the Short Message Service (SMS) protocol is defined in 3GPP TS 24.011 [8].

---

## 5 Structure of layer 3 functions

### 5.1 Basic groups of functions

Same as clause 5.1 of GMPRS-1 04.007 [3].

## 5.2 Protocol architecture

Same as clause 5.1 of GMPRS-1 04.007 [3] with the following additional text:

Figure 5.5 shows the protocol architecture for a MES supporting the PS mode of operation UMTS service.

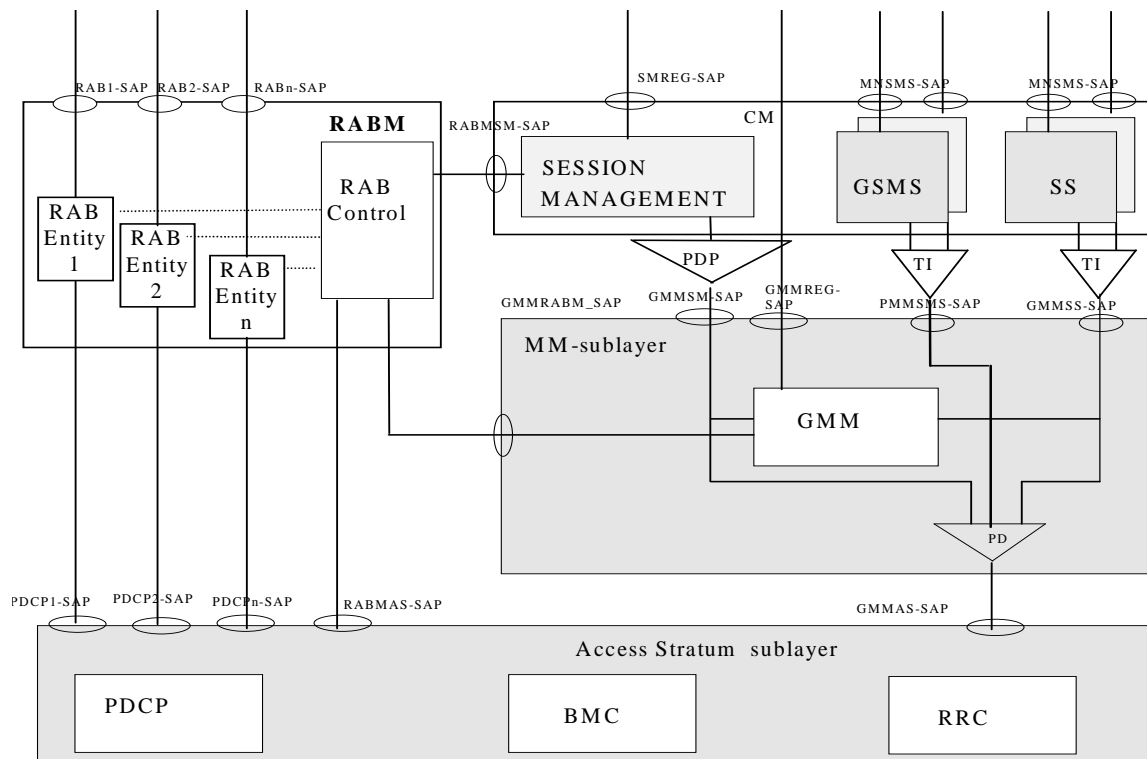

**Figure 5.5: Protocol architecture of Non Access Stratum supporting PS mode of operation MESs, MES-side**

Figure 5.5 defines three sublayers for UMTS PS domain services supporting PS mode of operation:

- the Access Stratum (AS) sublayer provides services to the MM sublayer and the RAB Manager (RABM) entity;
- the MM sublayer provides services to the SM, SS and GSMS entities of the CM. The MM sublayer includes one GMM entity;
- the CM sublayer includes the SM, SS and GSMS entities. The SM entity provides services to the RABM entity and uses services of the MM sublayer. The GSMS entity is identical to the SMS entity for GPRS services in GSM except it uses the services from the GMM sublayer. The SS entity is identical to the one for non-GPRS services except it uses the services from the LLC or PS signalling connection;
- the RABM hides the concepts of RABs that can be activated/released while a PDP context is active. If UL data in the terminal is to be sent on a RAB (NSAPI) that has been released the RABM will trigger a service request procedure in GMM.

## 6 Services provided by signalling layer 3 at the MS side

Same as clause 6 of GMPRS-1 04.007 [3].

## 6.1 Registration services

Same as clause 6.1 of GMPRS-1 04.007 [3].

## 6.2 Call Control services

Same as clause 6.2 of GMPRS-1 04.007 [3].

## 6.3 Call-independent supplementary services support

Same as clause 6.3 of GMPRS-1 04.007 [3].

## 6.4 Short Message Services support

Same as clause 6.4 of GMPRS-1 04.007 [3].

## 6.5 MN-RR state services support

Same as clause 6.5 of GMPRS-1 04.007 [3].

## 6.6 Position information support

Same as clause 6.6 of GMPRS-1 04.007 [3].

## 6.7 DTMF digits transmission and reception service

Same as clause 6.7 of GMPRS-1 04.007 [3].

## 6.8 Session Management Services for GMPRS-Services

Same as clause 6.5 of 3GPP TS 24.007 [5].

## 6.9 Registration Services for GMPRS-Services

Same as clause 6.9 of GMPRS-1 04.007 [3].

## 6.10 Services provided to SNDCP entities by GMPRS Logical Link Control services

Same as clause 6.10 of GMPRS-1 04.007 [3].

## 6.11 Dark-beam information support

Same as clause 6.11 of GMPRS-1 04.007 [3].

---

## 7 Services provided by signalling layer 3 on the Network side

### 7.1 Call Control services

Same as clause 7.1 of GMPRS-1 04.007 [3].

### 7.2 Call-independent supplementary services support

Same as clause 7.2 of GMPRS-1 04.007 [3].

### 7.3 Short Message Services support

Same as clause 7.3 of GMPRS-1 04.007 [3].

### 7.4 Services provided to SMDCP and SMS entities by GMPRS Logical Link Control services

Same as clause 7.4 of GMPRS-1 04.007 [3].

### 7.5 Session Management services for GMPRS-1

Same as clause 7.5 of 3GPP TS 24.007 [5].

---

## 8 Services assumed from signalling layers 1 and 2

Same as clause 8 of GMPRS-1 04.007 [3].

---

## 9 Interlayer service interfaces on the MES side

### 9.1 Services provided by the Radio Resource management entity

Same as clause 9.1 of GMPRS-1 04.007 [3].

#### 9.1.1 Service state diagram

Same as clause 9.1.1 of GMPRS-1 04.007 [3].

#### 9.1.2 Service primitives

Same as clause 9.1.2 of GMPRS-1 04.007 [3].

### 9.2 Services provided by the Mobility Management entity

Same as clause 9.2 of GMPRS-1 04.007 [3].

### 9.2.1 Service state diagram

Same as clause 9.2.1 of GMPRS-1 04.007 [3].

### 9.2.2 Service primitives

Same as clause 9.2.2 of GMPRS-1 04.007 [3].

## 9.3 Services provided by radio resource management entity for GMPRS services

Same as clause 9.3 of GMPRS-1 04.007 [3].

### 9.3.1 Service primitives for GRR-SAP (A/Gb mode only)

Same as clause 9.3.1 of GMPRS-1 04.007 [3].

### 9.3.2 Service primitives for GMMRR-SAP (A/Gb mode only)

Same as clause 9.3.2 of GMPRS-1 04.007 [3].

### 9.3.3 Service primitives for RABMAS-SAP (Iu mode only)

Same as clause 9.3.3. of 3GPP TS 24.007 [5].

### 9.3.4 Service primitives for GMMAS-SAP (Iu mode only)

Same as clause 9.3.4. of 3GPP TS 24.007 [5].

## 9.4 Services provided by LLC entity for GMPRS services (A/Gb mode only)

Same as clause 9.4 of GMPRS-1 04.007 [3].

## 9.5 Registration Services provided for GMPRS services

### 9.5.1 Service primitives for GMMSM-SAP

Same as clause 9.5.1 of GMPRS-1 04.007 [3].

### 9.5.2 Void

### 9.5.3 Service primitives for GMMSMS-SAP

Same as clause 9.5.3 of GMPRS-1 04.007 [3].

### 9.5.4 Service primitives for PMMSMS-SAP (Iu mode only)

Same as clause 9.5.4 of 3GPP TS 24.007 [5].

### 9.5.5 Service primitives for GMMRABM-SAP (lu mode only)

Same as clause 9.5.5 of 3GPP TS 24.007 [5].

---

## 10 Interlayer service interfaces on the Network side

Same as clause 10 of GMPRS-1 04.007 [3].

---

## 11 Standard layer 3 messages

Same as clause 11 of GMPRS-1 04.007 [3].

### 11.1 Components of a standard layer 3 message

Same as clause 11.1 of GMPRS-1 04.007 [3].

### 11.2 Imperative part of a standard layer 3 message

Same as clause 11.2 of GMPRS-1 04.007 [3].

#### 11.2.1 Protocol discriminator

Same as clause 11.2.1 of GMPRS-1 04.007 [3].

#### 11.2.2 Skip Indicator

Same as clause 11.2.2 of GMPRS-1 04.007 [3].

#### 11.2.3 Transaction identifier

Same as clause 11.2.3 of GMPRS-1 04.007 [3].

#### 11.2.4 Message type

Same as clause 11.2.4 of GMPRS-1 04.007 [3].

#### 11.2.5 Further information elements of the imperative part

Same as clause 11.2.5 of GMPRS-1 04.007 [3].

### 11.3 Non-imperative part of a standard layer 3 message

Same as clause 11.3 of GMPRS-1 04.007 [3].

### 11.4 Presence requirements of information elements

Same as clause 11.4 of GMPRS-1 04.007 [3].

## 11.5 Handling of superfluous information

Same as clause 11.5 of GMPRS-1 04.007 [3].

### 11.5.1 Information elements that are unnecessary in a message

Same as clause 11.5.1 of GMPRS-1 04.007 [3].



---

## Annex A (informative): MN-Service arrow diagram

Same as annex A of GMPRS-1 04.007 [3].

---

## Annex B (informative): Description of CSN.1

Same as annex B of GMPRS-1 04.007 [3].

---

## Annex C (informative): GPRS-Services sequence diagram

Same as annex C of GMPRS-1 04.007 [3].

---

## History

<b>Document history</b>		
V3.2.1	February 2011	Publication