

# ETSI TS 101 376-4-2 V1.1.1 (2001-03)

---

*Technical Specification*

**GEO-Mobile Radio Interface Specifications;  
Part 4: Radio interface protocol specifications;  
Sub-part 2: GMR-1 Satellite Network Access  
Reference Configuration;  
GMR-1 04.002**

---



---

**Reference**

DTS/SES-001-04002

---

**Keywords**

GMR, MSS, MES, satellite, GSO, GSM, S-PCN,  
access, configuration, interface, mobile, network,  
radio

**ETSI**

650 Route des Lucioles  
F-06921 Sophia Antipolis Cedex - FRANCE

Tel.: +33 4 92 94 42 00 Fax: +33 4 93 65 47 16

Siret N° 348 623 562 00017 - NAF 742 C  
Association à but non lucratif enregistrée à la  
Sous-Préfecture de Grasse (06) N° 7803/88

---

**Important notice**

Individual copies of the present document can be downloaded from:

<http://www.etsi.org>

The present document may be made available in more than one electronic version or in print. In any case of existing or perceived difference in contents between such versions, the reference version is the Portable Document Format (PDF). In case of dispute, the reference shall be the printing on ETSI printers of the PDF version kept on a specific network drive within ETSI Secretariat.

Users of the present document should be aware that the document may be subject to revision or change of status. Information on the current status of this and other ETSI documents is available at <http://www.etsi.org/tb/status/>

If you find errors in the present document, send your comment to:  
editor@etsi.fr

---

**Copyright Notification**

No part may be reproduced except as authorized by written permission.  
The copyright and the foregoing restriction extend to reproduction in all media.

© European Telecommunications Standards Institute 2001.  
All rights reserved.

---

# Contents

Intellectual Property Rights .....	4
Foreword .....	6
Introduction .....	7
1 Scope .....	8
2 References .....	8
3 Terminology and abbreviations .....	9
3.1 Terminology .....	9
3.2 Abbreviations .....	9
4 General definitions .....	9
4.1 Reference configurations .....	9
4.2 Functional groups .....	9
4.3 Reference points .....	9
4.4 GMR-1 interface points .....	9
5 GMR-1 reference configuration .....	10
5.1 Mobile Earth Station-Mobile Termination (MES-MT) .....	10
5.2 Gateway Station + MSC (GS/MSC) .....	10
6 Physical realization .....	11
<b>Annex A (informative): Bibliography .....</b>	<b>12</b>
History .....	14

## Intellectual Property Rights

The information pertaining to essential IPRs is publicly available for **ETSI members and non-members**, and can be found in ETSI SR 000 314: "*Intellectual Property Rights (IPRs); Essential, or potentially Essential, IPRs notified to ETSI in respect of ETSI standards*", which is available from the ETSI Secretariat. Latest updates are available on the ETSI Web server (<http://www.etsi.org/ipr>).

The attention of ETSI has been drawn to the Intellectual Property Rights (IPRs) listed below which are, or may be, or may become, Essential to the present document. The IPR owner has undertaken to grant irrevocable licences, on fair, reasonable and non-discriminatory terms and conditions under these IPRs pursuant to the ETSI IPR Policy. Further details pertaining to these IPRs can be obtained directly from the IPR owner.

The present IPR information has been submitted to ETSI and pursuant to the ETSI IPR Policy, no investigation, including IPR searches, has been carried out by ETSI. No guarantee can be given as to the existence of other IPRs not referenced in ETSI SR 000 314 (or the updates on the ETSI Web server) which are, or may be, or may become, essential to the present document.

### IPRs:

Project	Company	Title	Country of Origin	Patent n°	Countries Applicable
TS 101 376 V1.1.1	Digital Voice Systems Inc		US	US 5,226,084	US
TS 101 376 V1.1.1	Digital Voice Systems Inc		US	US 5,715,365	US
TS 101 376 V1.1.1	Digital Voice Systems Inc		US	US 5,826,222	US
TS 101 376 V1.1.1	Digital Voice Systems Inc		US	US 5,754,974	US
TS 101 376 V1.1.1	Digital Voice Systems Inc		US	US 5,701,390	US

IPR Owner: Digital Voice Systems Inc  
One Van de Graaff Drive Burlington,  
MA 01803  
USA

Contact: John C. Hardwick  
Tel.: +1 781-270-1030  
Fax: +1 781-270-0166

Project	Company	Title	Country of Origin	Patent n°	Countries Applicable
TS 101 376 V1.1.1	Ericsson Mobile Communication	Improvements in, or in relation to, equalisers	GB	GB 2 215 567	GB
TS 101 376 V1.1.1	Ericsson Mobile Communication	Power Booster	GB	GB 2 251 768	GB
TS 101 376 V1.1.1	Ericsson Mobile Communication	Receiver Gain	GB	GB 2 233 846	GB
TS 101 376 V1.1.1	Ericsson Mobile Communication	Transmitter Power Control for Radio Telephone System	GB	GB 2 233 517	GB

IPR Owner: Ericsson Mobile Communications (UK) Limited  
The Keytech Centre, Ashwood Way  
Basingstoke  
Hampshire RG23 8BG  
United Kingdom

Contact: John Watson  
Tel.: +44 1256 864821

Project	Company	Title	Country of Origin	Patent n°	Countries Applicable
TS 101 376 V1.1.1	Hughes Network Systems		US	Pending	US

IPR Owner: Hughes Network Systems  
11717 Exploration Lane  
Germantown, Maryland 20876  
USA

Contact: John T. Whelan  
Tel: +1 301-428-7172  
Fax: +1 301-428-2802

Project	Company	Title	Country of Origin	Patent n°	Countries Applicable
TS 101 376 V1.1.1	Lockheed Martin Global Telecommunic. Inc	2.4-to-3 KBPS Rate Adaptation Apparatus for Use in Narrowband Data and Facsimile Communication Systems	US	US 6,108,348	US
TS 101 376 V1.1.1	Lockheed Martin Global Telecommunic. Inc	Cellular Spacecraft TDMA Communications System with Call Interrupt Coding System for Maximizing Traffic Throughput	US	US 5,717,686	US
TS 101 376 V1.1.1	Lockheed Martin Global Telecommunic. Inc	Enhanced Access Burst for Random Access Channels in TDMA Mobile Satellite System	US	US 5,875,182	
TS 101 376 V1.1.1	Lockheed Martin Global Telecommunic. Inc	Spacecraft Cellular Communication System	US	US 5,974,314	US
TS 101 376 V1.1.1	Lockheed Martin Global Telecommunic. Inc	Spacecraft Cellular Communication System	US	US 5,974,315	US
TS 101 376 V1.1.1	Lockheed Martin Global Telecommunic. Inc	Spacecraft Cellular Communication System with Mutual Offset High-margin Forward Control Signals	US	US 6,072,985	US
TS 101 376 V1.1.1	Lockheed Martin Global Telecommunic. Inc	Spacecraft Cellular Communication System with Spot Beam Pairing for Reduced Updates	US	US 6,118,998	US

IPR Owner: Lockheed Martin Global Telecommunications, Inc.  
900 Forge Road  
Norrstown, PA. 19403  
USA

Contact: R.F. Franciose  
Tel.: +1 610.354.2535  
Fax: +1 610.354.7244

---

# Foreword

This Technical Specification (TS) has been produced by ETSI Technical Committee Satellite Earth Stations and Systems (SES).

The contents of the present document are subject to continuing work within TC-SES and may change following formal TC-SES approval. Should TC-SES modify the contents of the present document, it will then be republished by ETSI with an identifying change of release date and an increase in version number as follows:

Version 1.m.n

where:

- the third digit (n) is incremented when editorial only changes have been incorporated in the specification;
- the second digit (m) is incremented for all other types of changes, i.e. technical enhancements, corrections, updates, etc.

The present document is part 4, sub-part 2 of a multi-part deliverable covering the GEO-Mobile Radio Interface Specifications, as identified below:

Part 1: "General specifications";

Part 2: "Service specifications";

Part 3: "Network specifications";

**Part 4: "Radio interface protocol specifications";**

Sub-part 1: "Mobile Earth Station-Gateway Station System (MES-GSS) Interface; GMR-1 04.001";

**Sub-part 2: "GMR-1 Satellite Network Access Reference Configuration; GMR-1 04.002";**

Sub-part 3: "Channel Structures and Access Capabilities; GMR-1 04.003";

Sub-part 4: "Layer 1 General Requirements; GMR-1 04.004";

Sub-part 5: "Data Link Layer General Aspects; GMR-1 04.005";

Sub-part 6: "Mobile earth Station-Gateway Station Interface Data Link Layer Specifications; GMR-1 04.006";

Sub-part 7: "Mobile Radio Interface Signalling Layer 3 General Aspects; GMR-1 04.007";

Sub-part 8: "Mobile Radio Interface Layer 3 Specifications; GMR-1 04.008";

Sub-part 9: "Performance Requirements on the Mobile Radio Interface; GMR-1 04.013";

Sub-part 10: "Rate Adaptation on the Access Terminal-Gateway Station Subsystem (MES-GSS) Interface; GMR-1 04.021";

Sub-part 11: "Radio Link Protocol (RLP) for Data Services; GMR-1 04.022";

Part 5: "Radio interface physical layer specifications";

Part 6: "Speech coding specifications";

Part 7: "Terminal adaptor specifications".

---

## Introduction

GMR stands for GEO (Geostationary Earth Orbit) Mobile Radio interface, which is used for mobile satellite services (MSS) utilizing geostationary satellite(s). GMR is derived from the terrestrial digital cellular standard GSM and supports access to GSM core networks.

Due to the differences between terrestrial and satellite channels, some modifications to the GSM standard are necessary. Some GSM specifications are directly applicable, whereas others are applicable with modifications. Similarly, some GSM specifications do not apply, while some GMR specifications have no corresponding GSM specification.

Since GMR is derived from GSM, the organization of the GMR specifications closely follows that of GSM. The GMR numbers have been designed to correspond to the GSM numbering system. All GMR specifications are allocated a unique GMR number as follows:

GMR-n xx.zyy

where:

- xx.0yy ( $z = 0$ ) is used for GMR specifications that have a corresponding GSM specification. In this case, the numbers xx and yy correspond to the GSM numbering scheme.
- xx.2yy ( $z = 2$ ) is used for GMR specifications that do not correspond to a GSM specification. In this case, only the number xx corresponds to the GSM numbering scheme and the number yy is allocated by GMR.
- n denotes the first ( $n = 1$ ) or second ( $n = 2$ ) family of GMR specifications.

A GMR system is defined by the combination of a family of GMR specifications and GSM specifications as follows:

- If a GMR specification exists it takes precedence over the corresponding GSM specification (if any). This precedence rule applies to any references in the corresponding GSM specifications.

NOTE: Any references to GSM specifications within the GMR specifications are not subject to this precedence rule. For example, a GMR specification may contain specific references to the corresponding GSM specification.

- If a GMR specification does not exist, the corresponding GSM specification may or may not apply. The applicability of the GSM specifications is defined in GMR-1 01.201 [2].

---

# 1 Scope

The present document describes the reference configuration for access to a GMR-1 Satellite Network.

A user accesses a GMR-1 Satellite Network via a number of interfaces, including the MES-GSS interface. The purpose of the present document is to indicate the possible access arrangements that may be used in conjunction with the MES-GSS interface.

The present document is based on GSM 04.02 [6].

---

# 2 References

The following documents contain provisions which, through reference in this text, constitute provisions of the present document.

- References are either specific (identified by date of publication and/or edition number or version number) or non-specific.
- For a specific reference, subsequent revisions do not apply.
- For a non-specific reference, the latest version applies.

- [1] GMR-1 01.004 (ETSI TS 101 376-1-1): "GEO-Mobile Radio Interface Specifications; Part 1: General specifications; Sub-part 1: Abbreviations and acronyms; GMR-1 01.004".
- [2] GMR-1 01.201 (ETSI TS 101 376-1-2): "GEO-Mobile Radio Interface Specifications; Part 1: General specifications; Sub-part 2: Introduction to the GMR-1 Family; GMR-1 01.201".
- [3] GMR-1 07.001 (ETSI TS 101 376-7-1): "GEO-Mobile Radio Interface Specifications; Part 7: Terminal adaptor specifications; Sub-part 1: General on Terminal Adaptation Functions (TAF) for Mobile Earth Stations (MES); GMR-1 07.001".
- [4] GMR-1 07.002 (ETSI TS 101 376-7-2): "GEO-Mobile Radio Interface Specifications; Part 7: Terminal adaptor specifications; Sub-part 2: Terminal Adaptation Functions (TAF) for Services Using Asynchronous Bearer capabilities; GMR-1 07.002".
- [5] GMR-1 07.003 (ETSI TS 101 376-7-3): "GEO-Mobile Radio Interface Specifications; Part 7: Terminal adaptor specifications; Sub-part 3: Terminal Adaptation Functions (TAF) for Services Using Synchronous Bearer Capacities; GMR-1 07.003".
- [6] GSM 04.02 (ETSI ETS 300 551): "European digital cellular telecommunications system (Phase 2); GSM Public Land Mobile Network (PLMN) access reference configuration (GSM 04.02 (V4.0.4))".
- [7] ITU-T Recommendation I.420: "Basic user-network interface".



---

## 3 Terminology and abbreviations

### 3.1 Terminology

For the purposes of the present document, in the context of the GMR-1 system, the terminology changes in annex A of document GMR-1 01.004 [1] shall be applied when comparing GSM and GMR-1 functionality.

### 3.2 Abbreviations

For the purposes of the present document, the following abbreviations apply:

MES	Mobile earth station
GMR-1	GEO-Mobile Radio
GSS	Gateway station system

Also Refer to GMR-1 01.004 [1].

---

## 4 General definitions

Same as clause 2 of GSM 04.02 [6].

### 4.1 Reference configurations

Same as clause 2.1 of GSM 04.02 [6].

### 4.2 Functional groups

Same as clause 2.2 of GSM 04.02 [6].

### 4.3 Reference points

Same as clause 2.3 of GSM 04.02 [6].

### 4.4 GMR-1 interface points

GMR-1 Interface Points are reference points within a GMR-1 satellite Network at which a GMR-1 specified interface is always identified.

## 5 GMR-1 reference configuration

The reference configuration for GMR-1 Satellite Network access interfaces is shown in figure 1.

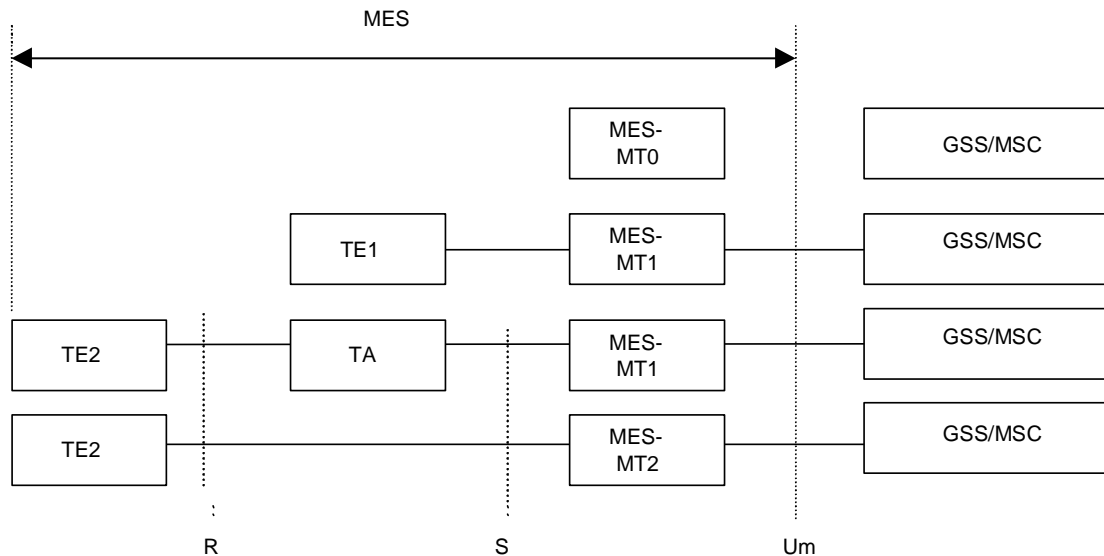

**Figure 1: GMR-1 Satellite network access reference configuration**

The terminal equipment functional groups TE1, TE2 and TA are conceptually the same functional groups as those in the ISDN. The two new functional groups are:

### 5.1 Mobile Earth Station-Mobile Termination (MES-MT)

which performs the same functions as GSM Mobile Termination (MT) described in clause 3.1 of GSM 04.02 [6].

There are three types of MES-MT:

- MES-MT0 includes functions belonging to the functional group MES-MT, with support of no terminal interfaces.
- MES-MT1 includes functions belonging to the functional group MES-MT, and with an interface that complies with the GMR-1 recommended subset of the ISDN user-network interface specifications.
- MES-MT2 includes functions belonging to the functional group MES-MT, and with an interface that complies with the GMR-1 recommended subset of the ITU-T X or V series interface recommendations.

The MES-MT plus any TE/(TE + TA) constitutes the Mobile Earth Station, MES.

### 5.2 Gateway Station + MSC (GS/MSC)

Same as clause 3.2 of GSM 04.02 [6].

## 6 Physical realization

In a GMR-1 Satellite Network, the reference point Um is a GMR-1 interface point, i.e. it is always implemented as a physical interface (according to GMR-1 Technical Specifications in the 04 and 05 series). The reference points S and R may be optionally implemented as physical interfaces. The implementation of interfaces at these reference points is according to GMR-1 07.001 [3], GMR-1 07.002 [4] and GMR-1 07.003 [5].

Figure 2 gives examples of configurations illustrating combinations of physical interfaces at reference points R and S. The examples shown are not exhaustive, but only serve to illustrate possible implementations of the respective functional blocks.

Example (a) of figure 2 illustrates a fully integrated MES including data terminal functions within the mobile earth station equipment.

Example (b) of figure 2 illustrates the connection of a TE1 in accordance with GMR-1 07.002 [4] and GMR-1 07.003 [5] (and ITU-T Recommendation I.420 [7]). In this example the speech service is offered via the TE1.

Example (c) of figure 2 illustrates the connection of a TE2 by a CCITT X or V series interface according to GMR-1 07.002 [4] and GMR-1 07.003 [5].

Example (d) of figure 2 illustrates the connection of a TE2 by means of an ISDN TA to the MES-MT equipment.

Example (e) of figure 2 illustrates the connection of a speech only MES.

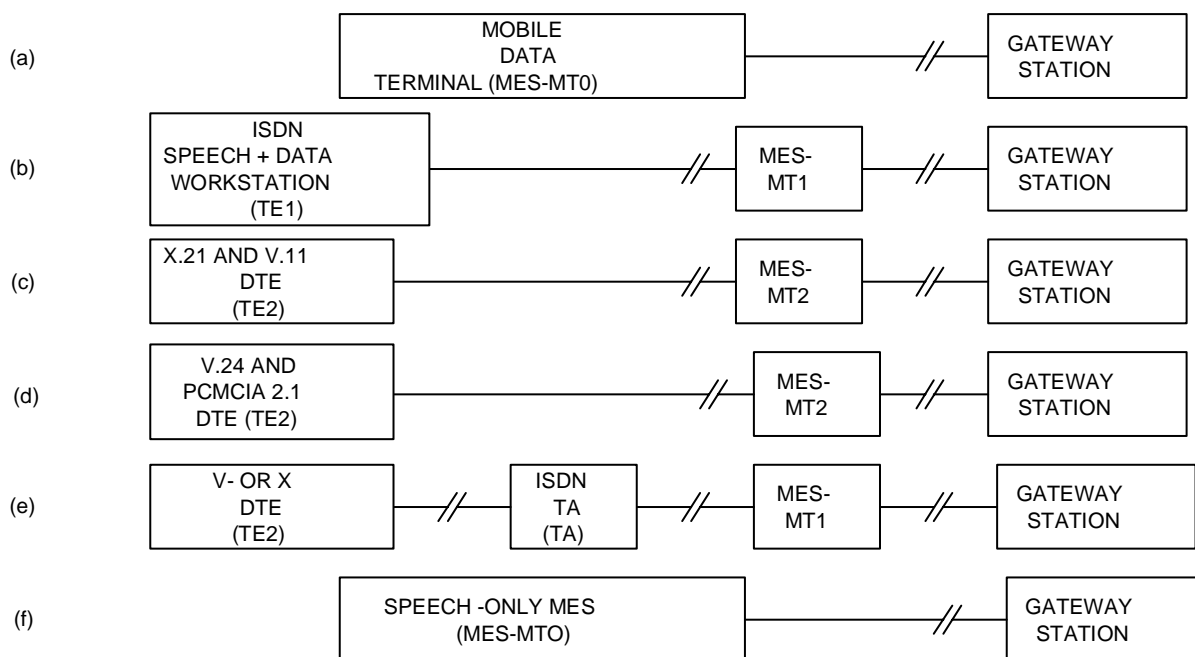

Figure 2: Examples of physical implementations

---

## Annex A (informative): Bibliography

ITU-T Series V Recommendations: "Data communication over the Telephone network".

ITU-T Series X Recommendations: "Data communication networks".

GMR-1 04.001 (ETSI TS 101 376-4-1): "GEO-Mobile Radio Interface Specifications; Part 4: Radio interface protocol specifications; Sub-part 1: Mobile Earth Station-Gateway Station System (MES-GSS) Interface; GMR-1 04.001".

GMR-1 04.003 (ETSI TS 101 376-4-3): "GEO-Mobile Radio Interface Specifications; Part 4: Radio interface protocol specifications; Sub-part 3: Channel Structures and Access Capabilities; GMR-1 04.003".

GMR-1 04.004 (ETSI TS 101 376-4-4): "GEO-Mobile Radio Interface Specifications; Part 4: Radio interface protocol specifications; Sub-part 4: Layer 1 General Requirements; GMR-1 04.004".

GMR-1 04.005 (ETSI TS 101 376-4-5): "GEO-Mobile Radio Interface Specifications; Part 4: Radio interface protocol specifications; Sub-part 5: Data Link Layer General Aspects; GMR-1 04.005".

GMR-1 04.006 (ETSI TS 101 376-4-6): "GEO-Mobile Radio Interface Specifications; Part 4: Radio interface protocol specifications; Sub-part 6: Mobile earth Station-Gateway Station Interface Data Link Layer Specifications; GMR-1 04.006".

GMR-1 04.007 (ETSI TS 101 376-4-7): "GEO-Mobile Radio Interface Specifications; Part 4: Radio interface protocol specifications; Sub-part 7: Mobile Radio Interface Signalling Layer 3 General Aspects; GMR-1 04.007".

GMR-1 04.008 (ETSI TS 101 376-4-8): "GEO-Mobile Radio Interface Specifications; Part 4: Radio interface protocol specifications; Sub-part 8: Mobile Radio Interface Layer 3 Specifications; GMR-1 04.008".

GMR-1 04.021 (ETSI TS 101 376-4-10): "GEO-Mobile Radio Interface Specifications; Part 4: Radio interface protocol specifications; Sub-part 10: Rate Adaptation on the Access Terminal-Gateway Station Subsystem (MES-GSS) Interface; GMR-1 04.021".

GMR-1 04.022 (ETSI TS 101 376-4-11): "GEO-Mobile Radio Interface Specifications; Part 4: Radio interface protocol specifications; Sub-part 11: Radio Link Protocol (RLP) for Data Services; GMR-1 04.022".

GMR-1 05.001 (ETSI TS 101 376-5-1): "GEO-Mobile Radio Interface Specifications; Part 5: Radio interface physical layer specifications; Sub-part 1: Physical Layer on the Radio Path: General Description; GMR-1 05.001".

GMR-1 05.002 (ETSI TS 101 376-5-2): "GEO-Mobile Radio Interface Specifications; Part 5: Radio interface physical layer specifications; Sub-part 2: Multiplexing and Multiple Access; Stage 2 Service Description; GMR-1 05.002".

GMR-1 05.003 (ETSI TS 101 376-5-3): "GEO-Mobile Radio Interface Specifications; Part 5: Radio interface physical layer specifications; Sub-part 3: Channel Coding; GMR-1 05.003".

GMR-1 05.004 (ETSI TS 101 376-5-4): "GEO-Mobile Radio Interface Specifications; Part 5: Radio interface physical layer specifications; Sub-part 4: Modulation; GMR-1 05.004".

GMR-1 05.005 (ETSI TS 101 376-5-5): "GEO-Mobile Radio Interface Specifications; Part 5: Radio interface physical layer specifications; Sub-part 5: Radio Transmission and Reception; GMR-1 05.005".

GMR-1 05.008 (ETSI TS 101 376-5-6): "GEO-Mobile Radio Interface Specifications; Part 5: Radio interface physical layer specifications; Sub-part 6: Radio Subsystem Link Control; GMR-1 05.008".

GMR-1 05.010 (ETSI TS 101 376-5-7): "GEO-Mobile Radio Interface Specifications; Part 5: Radio interface physical layer specifications; Sub-part 7: Radio Subsystem Synchronisation; GMR-1 05.010".

GSM 02.02 (ETSI ETS 300 501): "European digital cellular telecommunications system (Phase 2); Bearer Services (BS) supported by a GSM Public Land Mobile Network (PLMN); (GSM 02.02 (V4.2.2))".

GSM 04.10 (ETSI ETS 300 558): "Digital cellular telecommunications system (Phase 2); Mobile radio interface layer 3; Supplementary services specification; General aspects; (GSM 04.10 (V4.10.1))".

GSM 04.11 (ETSI ETS 300 559): "Digital cellular telecommunications system (Phase 2); Point-to-Point (PP) Short Message Service (SMS) support on mobile radio interface; (GSM 04.11 (V4.10.0))".

GSM 04.12 (ETSI ETS 300 560): "Digital cellular telecommunications system (Phase 2); Short Message Service Cell Broadcast (SMSCB) support on the mobile radio interface; (GSM 04.12 (V4.6.0))".

GSM 04.13 (ETSI ETS 300 561): "Digital cellular telecommunications system (Phase 2); Performance requirements on the mobile radio interface; (GSM 04.13 (V4.2.0))".

GSM 04.80 (ETSI ETS 300 564): "Digital cellular telecommunications system (Phase 2); Mobile radio interface layer 3; Supplementary services specification; Formats and coding; (GSM 04.80 (V4.11.1))".

GSM 04.81 (ETSI ETS 300 565): "European digital cellular telecommunications system (Phase 2); Line identification supplementary services; Stage 3; (GSM 04.81 (V4.4.1))".

GSM 04.82 (ETSI ETS 300 566): "Digital cellular telecommunications system (Phase 2); Call Forwarding (CF) supplementary services; Stage 3; (GSM 04.82 (V4.9.1))".

GSM 04.83 (ETSI ETS 300 567): "Digital cellular telecommunications system (Phase 2); Call Waiting (CW) and Call Hold (HOLD) supplementary services; Stage 3; (GSM 04.83 (V4.6.1))".

GSM 04.84 (ETSI ETS 300 568): "European digital cellular telecommunications system (Phase 2); Multi Party (MPTY) supplementary services; Stage 3; (GSM 04.84 (V4.3.2))".

GSM 04.85 (ETSI ETS 300 569): "Digital cellular telecommunications system (Phase 2); Closed User Group (CUG) supplementary services; Stage 3 (GSM 04.85 (V4.1.1))".

GSM 04.86 (ETSI ETS 300 570): "European digital cellular telecommunications system (Phase 2); Advice of Charge (AoC) supplementary services; Stage 3; (GSM 04.86 (V4.5.2))".

GSM 04.88 (ETSI ETS 300 571): "Digital cellular telecommunications system (Phase 2); Call Barring (CB) supplementary services; Stage 3; (GSM 04.88 (V4.7.1))".

GSM 04.90 (ETSI ETS 300 572): "European digital cellular telecommunications system (Phase 2); Unstructured Supplementary Service Data (USSD); Stage 3; (GSM 04.90 (V4.1.1))".

GSM 05.90 (ETSI ETR 108): "European digital cellular telecommunications system (Phase 2); GSM Electro Magnetic Compatibility (EMC) considerations; (GSM 05.90 (V4.3.0))".

---

## History

<b>Document history</b>		
V1.1.1	March 2001	Publication