

# ETSI TS 101 343 V6.7.1 (2000-05)

---

*Technical Specification*

**Digital cellular telecommunications system (Phase 2+);  
General Packet Radio Service (GPRS);  
Base Station System (BSS) -  
Serving GPRS Support Node (SGSN);  
BSS GPRS Protocol (BSSGP)  
(GSM 08.18 version 6.7.1 Release 1997)**

---



**GSM**®  
GLOBAL SYSTEM FOR  
MOBILE COMMUNICATIONS

**ETSI** 

---

Reference

---

RTS/SMG-020818Q6R6

Keywords

---

Digital cellular telecommunications system,  
Global System for Mobile communications (GSM)  
Service, Packet Mode, Radio, GSM,  
GSM\_Phase2\_plus, Stage 2

**ETSI**

650 Route des Lucioles  
F-06921 Sophia Antipolis Cedex - FRANCE

---

Tel.: +33 4 92 94 42 00 Fax: +33 4 93 65 47 16

Siret N° 348 623 562 00017 - NAF 742 C  
Association à but non lucratif enregistrée à la  
Sous-Préfecture de Grasse (06) N° 7803/88

***Important notice***

---

Individual copies of the present document can be downloaded from:

<http://www.etsi.org>

The present document may be made available in more than one electronic version or in print. In any case of existing or perceived difference in contents between such versions, the reference version is the Portable Document Format (PDF).

In case of dispute, the reference shall be the printing on ETSI printers of the PDF version kept on a specific network drive within ETSI Secretariat.

Users of the present document should be aware that the document may be subject to revision or change of status.

Information on the current status of this and other ETSI documents is available at <http://www.etsi.org/tb/status/>

If you find errors in the present document, send your comment to:

editor@etsi.fr

***Copyright Notification***

---

No part may be reproduced except as authorized by written permission.  
The copyright and the foregoing restriction extend to reproduction in all media.

© European Telecommunications Standards Institute 2000.  
All rights reserved.

# Contents

Intellectual Property Rights .....	7
Foreword .....	7
1 Scope .....	8
2 References .....	8
3 Abbreviations .....	9
4 Logical configuration of the Gb-interface .....	9
4.1 High-level characteristics of the Gb-interface .....	9
4.2 Position of BSSGP within the protocol stack on the Gb-interface .....	9
5 Elements for layer-to-layer communication .....	11
5.1 Definition of service model .....	11
5.2 Service primitives provided by the BSSGP at a BSS .....	12
5.2.1 RL-DL-UNITDATA.ind .....	13
5.2.2 RL-UL-UNITDATA.req .....	13
5.2.3 RL-PTM-UNITDATA.ind .....	13
5.2.4 GMM-PAGING.ind .....	13
5.2.5 GMM-RA-CAPABILITY.ind .....	13
5.2.6 GMM-RA-CAPABILITY-UPDATE.req .....	13
5.2.7 GMM-RA-CAPABILITY-UPDATE.cnf .....	14
5.2.8 GMM-RADIO-STATUS.req .....	14
5.2.9 GMM-SUSPEND.req .....	14
5.2.10 GMM-SUSPEND.cnf .....	14
5.2.11 GMM-RESUME.req .....	14
5.2.12 GMM-RESUME.cnf .....	14
5.2.13 NM-FLUSH-LL.ind .....	14
5.2.14 NM-FLUSH-LL.res .....	14
5.2.15 NM-LLC-DISCARDED.req .....	14
5.2.16 NM-FLOW-CONTROL-BVC.req .....	14
5.2.17 NM-FLOW-CONTROL-BVC.cnf .....	14
5.2.18 NM-FLOW-CONTROL-MS.req .....	14
5.2.19 NM-FLOW-CONTROL-MS.cnf .....	15
5.2.20 NM-STATUS.req .....	15
5.2.21 NM-STATUS.ind .....	15
5.2.22 NM-BVC-BLOCK.req .....	15
5.2.23 NM-BVC-BLOCK.cnf .....	15
5.2.24 NM-BVC-UNBLOCK.req .....	15
5.2.25 NM-BVC-UNBLOCK.cnf .....	15
5.2.26 NM-BVC-RESET.req .....	15
5.2.27 NM-BVC-RESET.res .....	15
5.2.28 NM-BVC-RESET.ind .....	15
5.2.29 NM-BVC-RESET.cnf .....	15
5.2.30 NM-TRACE.ind .....	15
5.3 Service primitives provided by the BSSGP at an SGSN .....	16
5.3.1 BSSGP-DL-UNITDATA.req .....	17
5.3.2 BSSGP-UL-UNITDATA.ind .....	17
5.3.3 BSSGP-PTM-UNITDATA.req .....	17
5.3.4 GMM-PAGING.req .....	17
5.3.5 GMM-RA-CAPABILITY.req .....	17
5.3.6 GMM-RA-CAPABILITY-UPDATE.ind .....	18
5.3.7 GMM-RA-CAPABILITY-UPDATE.res .....	18
5.3.8 GMM-RADIO-STATUS.ind .....	18
5.3.9 GMM-SUSPEND.ind .....	18
5.3.10 GMM-RESUME.ind .....	18
5.3.11 NM-FLUSH-LL.req .....	18

5.3.12	NM-FLUSH-LL.cnf.....	18
5.3.13	NM-LLC-DISCARDED.ind.....	18
5.3.14	NM-FLOW-CONTROL-BVC.ind.....	18
5.3.15	NM-FLOW-CONTROL-MS.ind.....	18
5.3.16	NM-STATUS.req.....	18
5.3.17	NM-STATUS.ind.....	18
5.3.18	NM-BVC-BLOCK.ind.....	19
5.3.19	NM-BVC-UNBLOCK.ind.....	19
5.3.20	NM-BVC-RESET.req.....	19
5.3.21	NM-BVC-RESET.res.....	19
5.3.22	NM-BVC-RESET.ind.....	19
5.3.23	NM-BVC-RESET.cnf.....	19
5.3.24	NM-TRACE.req.....	19
5.4	Primitive parameters.....	19
5.4.1	BSSGP Virtual Connection Identifier (BVCI).....	19
5.4.2	Link Selector Parameter (LSP).....	20
5.4.3	[functional-name] PDU.....	20
5.4.4	Network Service Entity Identifier (NSEI).....	20
6	User data and signalling procedures between RL and BSSGP SAPs.....	21
6.1	Downlink UNITDATA procedure.....	21
6.1.1	Abnormal conditions.....	22
6.2	Uplink UNITDATA procedure.....	22
6.2.1	Abnormal conditions.....	22
6.3	RA-CAPABILITY procedure.....	22
6.3.1	Abnormal conditions.....	22
7	Signalling procedures between GMM SAPs.....	23
7.1	Paging procedure.....	23
7.2	Radio Access Capability Update procedure.....	24
7.2.1	Abnormal conditions.....	24
7.3	Radio Status procedure.....	24
7.4	SUSPEND procedure.....	25
7.4.1	Abnormal conditions.....	25
7.5	RESUME procedure.....	25
7.5.1	Abnormal conditions.....	26
8	Signalling procedures between NM SAPs.....	26
8.1	FLUSH-LL (logical link) procedure.....	26
8.2	Flow Control procedure.....	27
8.2.1	General model of operation.....	27
8.2.2	Mode of operation.....	27
8.2.3	Flow Control of Traffic from an SGSN to BSS.....	27
8.2.3.1	Control of the downlink throughput by the SGSN.....	27
8.2.3.2	Flow Control Conformance Definition.....	28
8.2.3.3	Response time within the SGSN to flow control messages.....	30
8.2.3.4	Frequency of sending BVC or MS Flow Control PDUs.....	30
8.2.3.5	FLOW-CONTROL PDUs.....	30
8.2.3.6	Condition of Bmax for MS after Initial Flow-Control-BVC.....	31
8.2.4	Flow Control of Uplink Traffic from a BSS to an SGSN.....	31
8.3	BVC blocking and unblocking procedure.....	31
8.3.1	PTP BVC.....	31
8.3.2	Signalling BVC.....	32
8.3.3	Abnormal Conditions.....	32
8.4	BVC-RESET procedure.....	32
8.4.1	Signalling BVC.....	33
8.4.2	PTP BVC.....	33
8.4.3	Abnormal Conditions.....	34
8.5	Trace procedure.....	34

9	General Protocol Error Handling .....	34
10	PDU functional definitions and contents .....	35
10.1	General Structure Of A PDU .....	35
10.2	PDU functional definitions and contents at RL and BSSGP SAPs.....	35
10.2.1	DL-UNITDATA .....	35
10.2.2	UL-UNITDATA .....	36
10.2.3	RA-CAPABILITY .....	36
10.2.4	PTM-UNITDATA .....	36
10.3	PDU functional definitions and contents at GMM SAP .....	37
10.3.1	PAGING PS.....	37
10.3.2	PAGING CS .....	37
10.3.3	RA-CAPABILITY-UPDATE.....	38
10.3.4	RA-CAPABILITY-UPDATE-ACK .....	38
10.3.5	RADIO-STATUS .....	38
10.3.6	SUSPEND .....	39
10.3.7	SUSPEND-ACK.....	39
10.3.8	SUSPEND-NACK.....	39
10.3.9	RESUME.....	40
10.3.10	RESUME-ACK .....	40
10.3.11	RESUME-NACK.....	40
10.4	PDU functional definitions and contents at NM SAP.....	41
10.4.1	FLUSH-LL.....	41
10.4.2	FLUSH-LL-ACK .....	41
10.4.3	LLC-DISCARDED.....	41
10.4.4	FLOW-CONTROL-BVC .....	42
10.4.5	FLOW-CONTROL-BVC-ACK.....	42
10.4.6	FLOW-CONTROL-MS .....	42
10.4.7	FLOW-CONTROL-MS-ACK .....	43
10.4.8	BVC-BLOCK .....	43
10.4.9	BVC-BLOCK-ACK.....	43
10.4.10	BVC-UNBLOCK.....	43
10.4.11	BVC-UNBLOCK-ACK .....	44
10.4.12	BVC-RESET .....	44
10.4.13	BVC-RESET-ACK.....	44
10.4.14	STATUS .....	45
10.4.14.1	Static conditions for BVCI.....	45
10.4.15	SGSN-INVOKE-TRACE .....	45
11	General information elements coding .....	45
11.1	General structure of the information elements.....	45
11.2	Information element description.....	46
11.3	Information Element Identifier (IEI) .....	46
11.3.1	Alignment octets .....	46
11.3.2	Bmax default MS .....	47
11.3.3	BSS Area Indication .....	47
11.3.4	Bucket Leak Rate (R) .....	47
11.3.5	BVC Bucket Size.....	47
11.3.6	BVCI (BSSGP Virtual Connection Identifier).....	48
11.3.7	BVC Measurement .....	48
11.3.8	Cause .....	48
11.3.9	Cell Identifier.....	49
11.3.10	Channel needed.....	49
11.3.11	DRX Parameters .....	50
11.3.12	eMLPP-Priority.....	50
11.3.13	Flush Action.....	50
11.3.14	IMSI.....	50
11.3.15	LLC-PDU .....	51
11.3.16	LLC Frames Discarded .....	51
11.3.17	Location Area .....	51
11.3.18	Mobile Id .....	51

11.3.19 MS Bucket Size .....51  
11.3.20 MS Radio Access Capability .....52  
11.3.21 OMC Id.....52  
11.3.22 PDU In Error .....52  
11.3.23 PDU Lifetime.....52  
11.3.24 PDU Type.....53  
11.3.25 Priority .....53  
11.3.26 QoS Profile .....54  
11.3.27 Radio Cause .....54  
11.3.28 RA-Cap-UPD-Cause .....55  
11.3.29 Routeing Area .....55  
11.3.30 R\_default\_MS .....56  
11.3.31 Suspend Reference Number .....56  
11.3.32 Tag .....56  
11.3.33 Temporary logical link Identity (TLLI) .....56  
11.3.34 Temporary Mobile Subscriber Identity (TMSI).....57  
11.3.35 Trace Reference .....57  
11.3.36 Trace Type .....57  
11.3.37 TransactionId .....57  
11.3.38 Trigger Id.....57  
11.3.39 Number of octets affected .....58

12 List of system variables .....58  
12.1 General Variables .....58  
12.2 Flow control variables .....59

**Annex A (informative): Change Request History .....60**  
History .....61

---

## Intellectual Property Rights

IPRs essential or potentially essential to the present document may have been declared to ETSI. The information pertaining to these essential IPRs, if any, is publicly available for **ETSI members and non-members**, and can be found in SR 000 314: "*Intellectual Property Rights (IPRs); Essential, or potentially Essential, IPRs notified to ETSI in respect of ETSI standards*", which is available from the ETSI Secretariat. Latest updates are available on the ETSI Web server (<http://www.etsi.org/ipr>).

Pursuant to the ETSI IPR Policy, no investigation, including IPR searches, has been carried out by ETSI. No guarantee can be given as to the existence of other IPRs not referenced in SR 000 314 (or the updates on the ETSI Web server) which are, or may be, or may become, essential to the present document.

---

## Foreword

This Technical Specification (TS) has been produced by the Special Mobile Group (SMG).

The present document specifies or references procedures used on the Base Station System (BSS) to Serving GPRS Support Node (SGSN) interface for control of GSM packet data services within the digital cellular telecommunications system (Phase 2+).

The contents of the present document are subject to continuing work within SMG and may change following formal SMG approval. Should SMG modify the contents of the present document it will then be republished by ETSI with an identifying change of release date and an increase in version number as follows:

Version 6.x.y

where:

- 6 indicates release 1997 of GSM Phase 2+;
- x the second digit is incremented for all changes of substance, i.e. technical enhancements, corrections, updates, etc.
- y the third digit is incremented when editorial only changes have been incorporated in the specification.

---

# 1 Scope

The present document specifies or references procedures used on the Base Station System (BSS) to Serving GPRS Support Node (SGSN) interface for control of GSM packet data services.

The functional split between BSS and SGSN is defined in GSM 03.60 [7] which states that a BSS is responsible for local radio resource allocation. The required procedures between BSS and SGSN are defined in detail in the present document.

---

# 2 References

The following documents contain provisions which, through reference in this text, constitute provisions of the present document.

- References are either specific (identified by date of publication, edition number, version number, etc.) or non-specific.
- For a specific reference, subsequent revisions do not apply.
- For a non-specific reference, the latest version applies.
- A non-specific reference to an ETS shall also be taken to refer to later versions published as an EN with the same number.
- For this Release 1997 document, references to GSM documents are for Release 1997 versions (version 6.x.y).

- [1] GSM 01.04: "Digital cellular telecommunications system (Phase 2+); Abbreviations and acronyms".
- [2] GSM 01.61: "Digital cellular telecommunications system (Phase 2+); GPRS ciphering algorithm requirements".
- [3] GSM 02.60: "Digital cellular telecommunications system (Phase 2+); General Packet Radio Service (GPRS); Service description; Stage 1".
- [4] GSM 03.03: "Digital cellular telecommunications system (Phase 2+); Numbering, addressing and identification".
- [5] GSM 03.07: "Digital cellular telecommunications system (Phase 2+); Restoration procedures".
- [6] GSM 03.22: "Digital cellular telecommunications system (Phase 2+); Functions related to Mobile Station (MS) in idle mode and group receive mode".
- [7] GSM 03.60: "Digital cellular telecommunications system (Phase 2+); General Packet Radio Service (GPRS); Service description; Stage 2".
- [8] GSM 03.61: "Digital cellular telecommunications system (Phase 2+); General Packet Radio Service (GPRS); Point to Multipoint Multicast Service Description; Stage 2".
- [9] GSM 03.62: "Digital cellular telecommunications system (Phase 2+); General Packet Radio Service (GPRS); Point to Multipoint Group Call Service Description; Stage 2".
- [10] GSM 03.64: "Digital cellular telecommunications system (Phase 2+); Overall description of the General Packet Radio Service (GPRS) Radio interface; Stage 2".
- [11] GSM 04.08: "Digital cellular telecommunications system (Phase 2+); Mobile radio interface layer 3 specification".
- [12] GSM 04.64: "Digital cellular telecommunications system (Phase 2+), General Packet Radio Service (GPRS); Logical Link Control (LLC)".



- [13] GSM 04.65: “Digital cellular telecommunications system (Phase 2+); General Packet Radio Service (GPRS); Subnetwork Dependent Convergence Protocol (SNDCP)”.
- [14] GSM 08.08: “Digital cellular telecommunications system (Phase 2+); Mobile Switching Centre - Base Station System (MSC - BSS) interface: Layer 3 specification”.
- [15] GSM 08.14: “Digital cellular telecommunications system (Phase 2+); General Packet Radio Service (GPRS); Base Station System (BSS) - Serving GPRS Support Node (SGSN) interface; Gb Interface Layer 1”.
- [16] GSM 08.16: “Digital cellular telecommunications system (Phase 2+); General Packet Radio Service (GPRS); Base Station System (BSS) - Serving GPRS Support Node (SGSN) interface; Network Service”.
- [17] GSM 09.18: “Digital cellular telecommunications system (Phase 2+); General Packet Radio Service (GPRS); Serving GPRS Support Node (SGSN) - Visitors Location Register (VLR); Gs interface layer 3 specification”.
- [18] GSM 12.08: “Digital cellular telecommunications system (Phase 2); Subscriber and equipment trace”.
- [19] CCITT Recommendation X.200 (White Book): “Reference model of open systems interconnection for CCITT applications”.

---

## 3 Abbreviations

Unless listed below, abbreviations used in the present document are listed in GSM 01.04 [1] and in GSM 08.16 [16].

DL	Downlink
UL	Uplink
PS	Packet switched
CS	Circuit switched
NSE	Network Service Entity

---

## 4 Logical configuration of the Gb-interface

### 4.1 High-level characteristics of the Gb-interface

In contrast to the A-interface, where a single user has the sole use of a dedicated physical resource throughout the lifetime of a call irrespective of information flow, the Gb-interface allows many users to be multiplexed over a common physical resource.

GPRS signalling and user data may be sent on the same physical resources.

Access rates per user may vary from zero data to the maximum possible bandwidth (e.g. the available bit rate of an E1).

### 4.2 Position of BSSGP within the protocol stack on the Gb-interface

Across the Gb-interface the following peer protocols have been identified: the Base Station Subsystem GPRS Protocol (BSSGP) and the underlying network service (NS). The NS shall transport BSSGP PDUs between a BSS and an SGSN (refer to GSM 08.16 [16]).

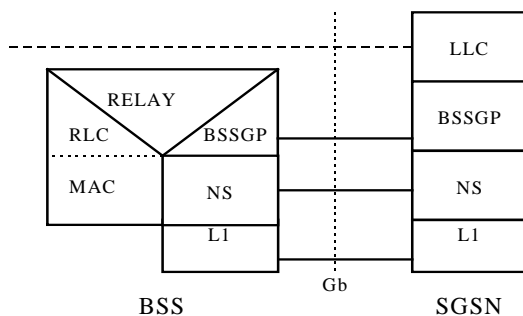

**Figure 4.1: BSSGP's position within the Gb-interface protocol stack**

NOTE: The Relay function provides buffering and parameter mapping between the RLC/MAC and the BSSGP. For example, on the uplink the RLC/MAC shall provide a TLLI. The Relay function shall then make it available to BSSGP. For a definition of the RLC/MAC function refer to GSM 03.64 [10].

The primary functions of the BSSGP include:

- in the downlink, the provision by an SGSN to a BSS of radio related information used by the RLC/MAC function;
- in the uplink, the provision by a BSS to an SGSN of radio related information derived from the RLC/MAC function; and
- the provision of functionality to enable two physically distinct nodes, an SGSN and a BSS, to operate node management control functions.

The present document describes the service model, service primitives, procedures and PDU formats of the BSSGP.

## 5 Elements for layer-to-layer communication

### 5.1 Definition of service model

In the present document, the communication between adjacent layers and the services provided by the layers are distributed by use of abstract service primitives. Only externally observable behaviour resulting from the description is normatively prescribed by the present document.

The service primitive model used in the present document is based on the concepts developed in CCITT Recommendation X.200 [19].

The service model for a BSS and an SGSN is asymmetric. The service models for a BSS and an SGSN are shown below.

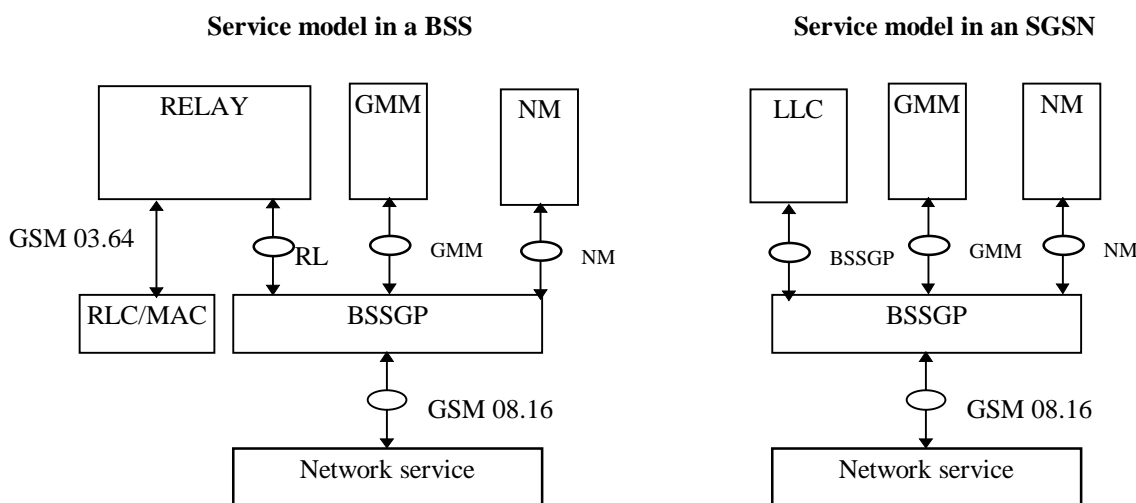

Figure 5.1: BSSGP service model

Primitives consist of commands and their respective responses associated with the services requested of another layer. The general syntax of a primitive is:

- XX - Generic name - Type (Parameters);

where XX designates the layer providing or using the service.

In the present document, XX is:

- “BSSGP” for functions controlling the transfer of LLC frames passed between an SGSN and an MS across the Gb interface;
- “RL” (relay) for functions controlling the transfer of LLC frames between the RLC/MAC function and BSSGP;
- “GMM” (GPRS mobility management) for functions associated with mobility management between an SGSN and a BSS; and
- “NM” (network management) for functions associated with Gb-interface and BSS—SGSN node management.

## 5.2 Service primitives provided by the BSSGP at a BSS

Table 5.2: Service primitives provided by BSSGP at a BSS

Generic name	Type				Parameters
	REQuest	INDication	RESponse	CoNFirm	
<b>RL ⇔ BSSGP</b>					
RL-DL-UNITDATA	-	X	-	-	BVCI, NSEI, Refer to DL-UNITDATA PDU
RL-UL-UNITDATA	X	-	-	-	BVCI, NSEI, LSP, Refer to UL- UNITDATA PDU
RL-PTM-UNITDATA	-	X	-	-	BVCI, NSEI, Refer to PTM-UNITDATA PDU
<b>GMM ⇔ BSSGP</b>					
GMM-PAGING	-	X	-	-	BVCI, NSEI, Refer to PAGING PS PDU Refer to PDU PAGING CS PDU
GMM-RA-CAPABILITY	-	X	-	-	BVCI, NSEI, Refer to RA-CAPABILITY PDU
GMM-RA-CAPABILITY- UPDATE	X	-	-	X	BVCI, NSEI, Refer to RA-CAPABILITY- UPDATE PDU, Refer to RA-CAPABILITY- UPDATE-ACK PDU
GMM-RADIO-STATUS	X	-	-	-	BVCI, NSEI, Refer to RADIO-STATUS PDU
GMM-SUSPEND	X	-	-	X	BVCI, NSEI, Refer to SUSPEND PDU Refer to SUSPEND- (N)ACK PDU
GMM-RESUME	X	-	-	X	BVCI, NSEI, Refer to RESUME PDU Refer to RESUME-(N)ACK PDU
<b>NM ⇔ BSSGP</b>					
NM-FLUSH-LL	-	X	X	-	BVCI, NSEI, Refer to FLUSH-LL PDU Refer to FLUSH-LL-ACK PDU
NM-LLC-DISCARDED	X	-	-	-	BVCI, NSEI, Refer to LLC-DISCARDED PDU
NM-FLOW-CONTROL-BVC	X	-	-	X	BVCI, NSEI, Refer to FLOW-CONTROL- BVC PDU Refer to FLOW-CONTROL- BVC ACK PDU

Generic name	Type				Parameters
	REQuest	INDication	RESponse	CoNFirm	
NM-FLOW-CONTROL-MS	X	-	-	X	BVCI, NSEI, Refer to FLOW-CONTROL-MS PDU Refer to FLOW-CONTROL-MS ACK PDU
NM-STATUS	X	X	-	-	BVCI, NSEI, Refer to STATUS PDU
NM-BVC-BLOCK	X	-	-	X	BVCI, NSEI, Refer to BVC-BLOCK PDU Refer to BVC-BLOCK-ACK PDU
NM-BVC-UNBLOCK	X	-	-	X	BVCI, NSEI, Refer to BVC-UNBLOCK PDU Refer to BVC-UNBLOCK-ACK PDU
NM-BVC-RESET	X	X	X	X	BVCI, NSEI, Refer to BVC-RESET PDU Refer to BVC-RESET-ACK PDU
NM-TRACE	-	X	-	-	BVCI, NSEI, Refer to SGSN-INVOKE-TRACE PDU

### 5.2.1 RL-DL-UNITDATA.ind

Receipt of a DL-UNITDATA PDU from an SGSN by a BSS containing an LLC-PDU and MS control information necessary for the transmission of the LLC-PDU across the radio interface.

### 5.2.2 RL-UL-UNITDATA.req

Request to send a UL-UNITDATA PDU to an SGSN from a BSS containing an LLC-PDU and radio interface derived information.

### 5.2.3 RL-PTM-UNITDATA.ind

This shall be developed in GPRS phase 2.

### 5.2.4 GMM-PAGING.ind

Receipt of a PAGING PS or PAGING CS PDU from an SGSN by a BSS containing instructions to page an MS within a given group of cells.

### 5.2.5 GMM-RA-CAPABILITY.ind

Receipt of a RA-CAPABILITY PDU from an SGSN by a BSS providing the new Radio Access capability of an MS.

### 5.2.6 GMM-RA-CAPABILITY-UPDATE.req

Request to send a RA-CAPABILITY-UPDATE PDU to an SGSN from a BSS in order to receive the current Radio Access capabilities of an MS.

### 5.2.7 GMM-RA-CAPABILITY-UPDATE.cnf

Receipt of a RA-CAPABILITY-UPDATE-ACK PDU from a SGSN by a BSS containing the current Radio Access capabilities of an MS.

### 5.2.8 GMM-RADIO-STATUS.req

Request to send a RADIO-STATUS PDU to an SGSN from a BSS to report that an exception condition occurred in the operation of the radio interface for an MS.

### 5.2.9 GMM-SUSPEND.req

Request to send a SUSPEND PDU to an SGSN from a BSS to mark an MS's GPRS service as suspended.

### 5.2.10 GMM-SUSPEND.cnf

Receipt of a SUSPEND-ACK PDU from an SGSN by a BSS confirming that an SGSN has marked an MS's GPRS service as suspended.

### 5.2.11 GMM-RESUME.req

Request to send a RESUME PDU to an SGSN from a BSS to mark an MS's GPRS service as resumed.

### 5.2.12 GMM-RESUME.cnf

Receipt of a RESUME-ACK PDU from an SGSN by a BSS confirming that an SGSN has marked an MS's GPRS service as resumed.

### 5.2.13 NM-FLUSH-LL.ind

On receipt of a FLUSH-LL PDU by a BSS from a SGSN, the BSS will either delete queued LLC-PDUs for a TLLI or move the queued LLC-PDUs from an old to a new BVC.

### 5.2.14 NM-FLUSH-LL.res

Sending of a FLUSH-LL-ACK PDU to the SGSN from a BSS to report if queued LLC-PDU(s) for an MS were deleted or transferred from the old to the new cell within the NSE.

### 5.2.15 NM-LLC-DISCARDED.req

Request to send a LLC-DISCARDED PDU to an SGSN from a BSS indicating that LLC frames pertaining to an MS have been locally discarded.

### 5.2.16 NM-FLOW-CONTROL-BVC.req

Request to send a FLOW-CONTROL PDU to an SGSN from a BSS indicating the ability of a BVC to accept a certain flow of data.

### 5.2.17 NM-FLOW-CONTROL-BVC.cnf

Confirmation that a FLOW-CONTROL PDU has been received by an SGSN for a given BVC.

### 5.2.18 NM-FLOW-CONTROL-MS.req

Request to send a FLOW-CONTROL PDU to an SGSN from a BSS indicating the ability to accept a certain flow of data for a given MS.

### 5.2.19 NM-FLOW-CONTROL-MS.cnf

Confirmation that a FLOW-CONTROL PDU has been received by an SGSN for a given MS.

### 5.2.20 NM-STATUS.req

Request to send a STATUS PDU to an SGSN from a BSS to report that an exception condition occurred within the BSS.

### 5.2.21 NM-STATUS.ind

Receipt of a STATUS PDU from an SGSN by a BSS indicating that an exception condition occurred within an SGSN.

### 5.2.22 NM-BVC-BLOCK.req

Request to send a BVC-BLOCK PDU to an SGSN from a BSS to mark a BVC as blocked.

### 5.2.23 NM-BVC-BLOCK.cnf

Receipt of a BVC-BLOCK-ACK PDU from an SGSN by a BSS confirming that an SGSN has marked a BVC as blocked.

### 5.2.24 NM-BVC-UNBLOCK.req

Request to send a BVC-UNBLOCK PDU to an SGSN from a BSS to mark a BVC as unblocked.

### 5.2.25 NM-BVC-UNBLOCK.cnf

Receipt of a BVC-UNBLOCK-ACK PDU from an SGSN by a BSS confirming that an SGSN has marked a BVC as unblocked.

### 5.2.26 NM-BVC-RESET.req

Request to send a BVC-RESET PDU to an SGSN from a BSS to reset an SGSN's GPRS BVC contexts.

### 5.2.27 NM-BVC-RESET.res

Sending of a BVC-RESET-ACK PDU to the SGSN from an BSS indicating that a GPRS BVC context has been reset in the BSS.

### 5.2.28 NM-BVC-RESET.ind

Receipt of a BVC-RESET PDU at a BSS from an SGSN indicating that GPRS BVC contexts have been reset at the SGSN.

### 5.2.29 NM-BVC-RESET.cnf

Receipt of a BVC-RESET-ACK PDU at a BSS confirming that GPRS BVC context has been reset at the SGSN.

### 5.2.30 NM-TRACE.ind

Receipt of a SGSN-INVOKE-TRACE PDU at a BSS from an SGSN indicating the need to produce a trace record on an MS.

## 5.3 Service primitives provided by the BSSGP at an SGSN

Table 5.3: Service primitives provided by BSSGP at an SGSN

Generic name	Type				Parameters
	REQuest	INDication	RESponse	CoNFirm	
<b>LL ⇄ BSSGP</b>					
BSSGP-DL-UNITDATA	X	-	-	-	BVCI, NSEI, LSP, Refer to DL-UNITDATA PDU
BSSGP-UL-UNITDATA	-	X			BVCI, NSEI, Refer to UL-UNITDATA PDU
BSSGP-PTM-UNITDATA	X	-	-	-	BVCI, NSEI, Refer to PTM-UNITDATA PDU
<b>GMM ⇄ BSSGP</b>					
GMM-PAGING	X	-	-	-	BVCI, NSEI, Refer to PAGING PS PDU Refer to PAGING CS PDU
GMM-RA-CAPABILITY	X				BVCI, NSEI, Refer to RA-CAPABILITY PDU
GMM-RA-CAPABILITY- UPDATE	-	X	X	-	BVCI, NSEI, Refer to RA-CAPABILITY- UPDATE PDU, Refer to RA-CAPABILITY- UPDATE-ACK PDU
GMM-RADIO-STATUS	-	X	-	-	BVCI, NSEI, Refer to RADIO-STATUS PDU
GMM-SUSPEND	-	X	-	-	BVCI, NSEI, Refer to SUSPEND PDU Refer to SUSPEND- (N)ACK PDU
GMM-RESUME	-	X	-	-	BVCI, NSEI, Refer to RESUME PDU Refer to RESUME-(N)ACK PDU
<b>NM ⇄ BSSGP</b>					
NM-FLUSH-LL	X	-	-	X	BVCI, NSEI, Refer to FLUSH-LL PDU Refer to FLUSH-LL-ACK PDU
NM-LLC-DISCARDED	-	X	-	-	BVCI, NSEI, Refer to LLC-DISCARDED PDU
NM-FLOW-CONTROL-BVC	-	X	-	-	BVCI, NSEI, Refer to FLOW-CONTROL- BVC PDU Refer to FLOW- CONTROL-BVC ACK PDU



Generic name	Type				Parameters
	REQuest	INDication	RESponse	CoNFirm	
NM-FLOW-CONTROL-MS	-	X	-	-	BVCI, NSEI, Refer to FLOW-CONTROL-MS PDU Refer to FLOW-CONTROL-MS ACK PDU
NM-STATUS	X	X	-	-	BVCI, NSEI, Refer to STATUS PDU
NM-BVC-BLOCK	-	X	-	-	BVCI, NSEI, Refer to BVC-BLOCK PDU Refer to BVC-BLOCK-ACK PDU
NM-BVC-UNBLOCK	-	X	-	-	BVCI, NSEI, Refer to BVC-UNBLOCK PDU Refer to BVC-UNBLOCK-ACK PDU
NM-BVC-RESET	X	X	X	X	BVCI, NSEI, Refer to BVC-RESET PDU Refer to BVC-RESET-ACK PDU
NM-TRACE	X	-	-	-	BVCI, NSEI, Refer to SGSN-INVOKE-TRACE PDU

NOTE: The parameters in the BSSGP-DL-UNITDATA and BSSGP-UL-UNITDATA primitives that are not included in the corresponding primitives in GSM 04.64 are provided or extracted by some intermediate function out of the scope of the present document.

### 5.3.1 BSSGP-DL-UNITDATA.req

Request to send a DL-UNITDATA PDU to a BSS from an SGSN containing an LLC-PDU and control information necessary for the transmission of the LLC-PDU across the radio interface.

### 5.3.2 BSSGP-UL-UNITDATA.ind

Receipt of a UL-UNITDATA PDU from a BSS by an SGSN containing an LLC-PDU and radio interface derived information.

### 5.3.3 BSSGP-PTM-UNITDATA.req

This shall be developed in GPRS phase 2.

### 5.3.4 GMM-PAGING.req

Request to send a PAGING PS or PAGING CS PDU from an SGSN to a BSS containing instructions to page an MS within a given group of cells.

### 5.3.5 GMM-RA-CAPABILITY.req

Request to send a RA-CAPABILITY PDU to the BSS from an SGSN containing the Radio Access capability of an MS.

### 5.3.6 GMM-RA-CAPABILITY-UPDATE.ind

Receipt of a RA-CAPABILITY-UPDATE PDU from a BSS by an SGSN, requesting that the SGSN sends the Radio Access capability of an MS to the BSS.

### 5.3.7 GMM-RA-CAPABILITY-UPDATE.res

Sending of a RA-CAPABILITY-UPDATE-ACK PDU to the BSS from an SGSN containing the current Radio Access capability of an MS.

### 5.3.8 GMM-RADIO-STATUS.ind

Receipt of a RADIO-STATUS PDU from a BSS by an SGSN to report that an exception condition occurred in the operation of the radio interface for an MS.

### 5.3.9 GMM-SUSPEND.ind

Receipt of a SUSPEND PDU from a BSS by an SGSN indicating that an MS wishes to suspended its GPRS service.

### 5.3.10 GMM-RESUME.ind

Receipt of a RESUME PDU from a BSS by an SGSN indicating that an MS wishes to resume its GPRS service.

### 5.3.11 NM-FLUSH-LL.req

Request to send a FLUSH-LL PDU from an SGSN to a BSS, instructing the BSS to either delete queued LLC-PDUs for a TLLI or move the queued LLC-PDUs from an old to a new BVC.

### 5.3.12 NM-FLUSH-LL.cnf

Receipt of a FLUSH-LL-ACK PDU at an SGSN informing if the queued LLC-PDU(s) for an MS were deleted or transferred from the old to the new cell within the NSE.

### 5.3.13 NM-LLC-DISCARDED.ind

Receipt of a LLC-DISCARDED PDU from a BSS by an SGSN indicating that LLC frames pertaining to an MS have been locally discarded.

### 5.3.14 NM-FLOW-CONTROL-BVC.ind

Receipt of a FLOW-CONTROL PDU from a BSS by an SGSN indicating the ability of a BVC to accept a certain flow of data.

### 5.3.15 NM-FLOW-CONTROL-MS.ind

Receipt of a FLOW-CONTROL PDU from a BSS by an SGSN indicating the ability to accept a certain flow of data for a given MS.

### 5.3.16 NM-STATUS.req

Request to send a STATUS PDU to a BSS from an SGSN to report that an exception condition occurred within an SGSN.

### 5.3.17 NM-STATUS.ind

Receipt of a STATUS PDU from a BSS by an SGSN indicating an exception condition occurred within the BSS.

### 5.3.18 NM-BVC-BLOCK.ind

Receipt of a BVC-BLOCK PDU from a BSS by an SGSN indicating that a BVC shall be marked as blocked.

### 5.3.19 NM-BVC-UNBLOCK.ind

Receipt of a BVC-UNBLOCK PDU from a BSS by an SGSN indicating that a BVC shall be marked as unblocked.

### 5.3.20 NM-BVC-RESET.req

Request to send a BVC-RESET PDU to a BSS from an SGSN to reset a BSS's GPRS BVC contexts.

### 5.3.21 NM-BVC-RESET.res

Sending of a BVC-RESET-ACK PDU to the BSS from a SGSN indicating that a GPRS BVC context has been reset in the SGSN.

### 5.3.22 NM-BVC-RESET.ind

Receipt of a BVC-RESET PDU at an SGSN from a BSS indicating that GPRS BVC contexts have been reset at the BSS.

### 5.3.23 NM-BVC-RESET.cnf

Receipt of a BVC-RESET-ACK PDU at an SGSN confirming that GPRS BVC contexts have been reset at the BSS.

### 5.3.24 NM-TRACE.req

Request to send an SGSN-INVOKE-TRACE PDU to a BSS from an SGSN to begin producing a trace record on an MS.

## 5.4 Primitive parameters

### 5.4.1 BSSGP Virtual Connection Identifier (BVCI)

BSSGP Virtual Connections (BVCs) provide communication paths between BSSGP entities. Each BVC is used in the transport of BSSGP PDUs between peer point-to-point (PTP) functional entities, peer point-to-multipoint (PTM) functional entities and peer signalling functional entities. Table 5.4 lists the mapping of the BSSGP PDU to the associated functional entity and the BVCI. The BVCI is used to enable the lower network service layer to efficiently route the BSSGP PDU to the peer entity. This parameter is not part of the BSSGP PDU across the Gb interface, but is used by the network service entity across the Gb.

Any BSSGP PDU received by the BSS or the SGSN containing a PDU type that does not fit, according to the mapping defined in table 5.4, with the functional entity identified by the BVCI provided by the network service entity, is discarded and a STATUS PDU with a cause value set to "Protocol error - unspecified" is sent.

A PTP functional entity is responsible for PTP user data transmission. There is one PTP functional entity per cell. Within GSM 08.18, a cell is identified by a BVCI unless it is explicitly stated otherwise.

A PTM functional entity is responsible for PTM user data transmission. There is one or more PTM functional entities per BSS.

A signalling functional entity is responsible for other functions e.g. paging. There is only one signalling entity per Network Service Entity (NSE). There is one or more NSEs per BSS.

Each BVC is identified by means of a BSSGP Virtual Connection Identifier (BVCI) which has end-to-end significance across the Gb interface. Each BVCI is unique between two peer Network Service Entities.

In the BSS, it shall be possible to configure BVCI statically by administrative means, or dynamically. In case of dynamic configuration, the BSSGP shall accept any BVCI passed by the underlying Network Service entity.

At the SGSN side, BVCI associated with PTP functional entities shall be dynamically configured. The BVCI associated with signalling functional entities and PTM functional entities are statically configured.

The BVCI value 0000 hex shall be used for the signalling functional entities.

The BVCI value 0001 hex shall be used for the PTM functional entities.

All other values may be used freely by the BSS and shall be accepted by the SGSN.

**Table 5.4: BSSGP PDU, BVCI and functional entity mapping**

BSSGP PDU	Mapping of BVCI to functional entity
DL-UNITDATA	PTP
UL-UNITDATA	PTP
RA-CAPABILITY	PTP
PTM-UNITDATA	PTM
PAGING-PS	PTP or SIGNALLING (NOTE 1)
PAGING-CS	PTP or SIGNALLING (NOTE 2)
RA-CAPABILITY-UPDATE / RA-CAPABILITY-UPDATE-ACK	PTP
RADIO-STATUS	PTP
SUSPEND / SUSPEND-ACK / SUSPEND-NACK	SIGNALLING
RESUME / RESUME-ACK / RESUME-NACK	SIGNALLING
FLUSH-LL / FLUSH-LL-ACK	SIGNALLING
LLC DISCARDED	SIGNALLING
FLOW-CONTROL-BVC / FLOW-CONTROL-BVC-ACK	PTP
FLOW-CONTROL-MS / FLOW-CONTROL-MS-ACK	PTP
STATUS	PTP or PTM or SIGNALLING (NOTE 3)
BVC-BLOCK / BVC-BLOCK-ACK	SIGNALLING
BVC-UNBLOCK / BVC-UNBLOCK-ACK	SIGNALLING
BVC-RESET / BVC-RESET-ACK	SIGNALLING
SGSN-INVOKE-TRACE	SIGNALLING

NOTE 1: The network may initiate paging of an MS in READY mobility management state at an indication of a lower layer failure (see GSM 04.08 subclause 4.7.9.1). In this case, the BVCI=PTP may be used.

NOTE 2: If the network initiates circuit-switched paging of a MS in READY mobility management state (e.g. a MS in class A or B mode of operation and in packet transfer mode), then the BVCI=PTP. If the MS is in STANDBY state, then the BVCI=SIGNALLING.

NOTE 3: The setting of the BVCI is dependent upon the context within which the STATUS PDU was generated.

## 5.4.2 Link Selector Parameter (LSP)

The link selector parameter is defined in GSM 08.16 [16]. At one side of the Gb interface, all BSSGP UNITDATA PDUs related to an MS shall be passed with the same LSP, e.g. the LSP is set to the MS's TLLI, to the underlying network service. The LSPs used at the BSS and SGSN for the same MS may be set to different values.

## 5.4.3 [functional-name] PDU

The parameters that make up a [functional-name] PDU are defined in PDU Functional Definitions and contents/GSM 08.18.

## 5.4.4 Network Service Entity Identifier (NSEI)

The Network Service Entity at the BSS and the SGSN provides the network management functionality required for the operation of the Gb interface. The Network Service Entity is described in GSM 08.16.

Each Network Service Entity is identified by means of a Network Service Entity Identifier (NSEI). The NSEI together with the BVCI uniquely identifies a BSGP Virtual Connection (e.g. a PTP functional entity) within an SGSN. The NSEI is used by the BSS and the SGSN to determine the NS-VCs that provides service to a BVCI.

---

## 6 User data and signalling procedures between RL and BSSGP SAPs

### 6.1 Downlink UNITDATA procedure

On the downlink, a DL-UNITDATA PDU shall contain information elements to be used by the RLC/MAC function and an LLC-PDU. There shall be only one LLC-PDU per DL-UNITDATA PDU. The LLC-PDU shall always be the last information element in the DL-UNITDATA PDU, and shall be aligned on a 32 bit boundary for efficient processing.

An SGSN provides the BSSGP with a current TLLI, identifying the MS. If an SGSN provides a second TLLI, indicating that an MS has recently changed its TLLI, this shall be considered as the "old" TLLI. A BSS uses the "old" TLLI to locate an MS's existing context. Subsequent uplink data transfers for this MS shall reference the current TLLI, and not the old TLLI.

The SGSN shall include the IMSI in the PDU. As an exception, the SGSN may omit the IMSI in the PDU if the mobile station identified by the TLLI is in MM non-DRX mode period (i.e. during a GMM procedure for *GPRS attach* or *routing area updating* defined in GSM 04.08 [11]) and the SGSN does not have a valid IMSI. If the SGSN has valid DRX Parameters for a TLLI, then the SGSN shall include them in the PDU. Nevertheless, the SGSN can omit the DRX Parameters if the MS identified with the TLLI is in MM non-DRX mode period to speed up the transmission of the LLC-PDU on the radio interface. The SGSN shall not send a DL-UNITDATA PDU without the DRX Parameters IE if the MS identified with the TLLI is not in MM non-DRX mode period.

An SGSN provides the BSSGP with MS specific information, enabling the RLC/MAC entity in a BSS to transmit an LLC-PDU to the MS in a user specific manner. The information made available to the radio interface includes:

- MS Radio Access Capability. This defines the radio capabilities of the ME. If there is valid MS Radio Access Capability information known by the SGSN for the associated MS, the SGSN shall include it in the DL-UNITDATA PDU. Otherwise, MS Radio Access Capability shall not be present;
- QoS Profile. This defines the (peak) bit rate, the type of BSSGP's SDU (signalling or data), the type of LLC frame (ACK, SACK, or not), the precedence class, and the transmission mode to be used when transmitting the LLC-PDU across the radio interface;
- PDU Lifetime. This defines the remaining time period that the PDU is considered as valid within the BSS. If the PDU is held for a period exceeding the "PDU Lifetime" time period, the PDU shall be locally discarded. The PDU Lifetime is set within the SGSN by the upper layers.

A BSS may incorporate the PDU Lifetime, the Precedence and the (peak) bit rate into its radio resource scheduler. The algorithm to do this is out of scope of the present document.

Two types of BSSGP SDU are distinguished within the QoS Profile : layer 3 signalling and data. Layer 3 signalling may be transmitted over the Um interface with higher protection.

The type of LLC frame indicates if the LLC frame type is an ACK or SACK command/response, or not (see GSM 04.64). An ACK or SACK command/response frame type may be transmitted over the Um interface with higher priority.

Two transmission modes across the radio interface are possible; acknowledged (using RLC/MAC ARQ functionality) and unacknowledged (using RLC/MAC unitdata functionality).

If Priority is present, only the priority-level field shall be regarded. The management of priority levels is implementation dependent and under operator control. The preemption capability indicator, the queuing allowed indicator and preemption vulnerability indicator shall be ignored.

In addition to constructing the DL-UNITDATA, the SGSN supplies the LSP, the BVCI and the NSEI associated with the MS to the lower layer network service, enabling network service routing to the peer entity. These parameters are not transmitted as part of the BSSGP across the Gb-interface.

### 6.1.1 Abnormal conditions

The following actions are defined in periods of congestion.

To satisfy the maximum number of service requests, the BSS may redistribute MSs among cells (i.e. network controlled cell reselection is initiated). If this occurs, the BSS may inform the SGSN through the RADIO STATUS PDU (Radio Cause value: cell reselection ordered). The BSS shall update any internal references that indicate the location of the MS. The BSS may attempt to internally re-route queued LLC frames to an MS that has been moved to a new cell. If this functionality is not supported, or if it is not possible to internally re-route LLC frames, the LLC frame shall be discarded.

It is the responsibility of the higher layer protocols in the SGSN to cope with discarded LLC frames.

## 6.2 Uplink UNITDATA procedure

On the uplink, a UL-UNITDATA PDU shall contain information elements derived from the RLC/MAC function, meaningful to higher-layer protocols in an SGSN, and an LLC-PDU. There shall be only one LLC-PDU per UL-UNITDATA PDU. The LLC-PDU shall always be the last information element in the UL-UNITDATA PDU, and shall be aligned on a 32 bit boundary for efficient processing.

The BSS shall provide the TLLI, received from the MS, to the SGSN.

The BSS shall provide a BVCI and an NSEI indicating the PTP functional entity (i.e. the cell) upon which the LLC-PDU was received. The SGSN shall obtain the BVCI and the NSEI from the underlying network service; the BVCI and the NSEI are not visible in the UL-UNITDATA PDU.

The BSS provides the SGSN with the QoS Profile used in the LLC-PDU's transmission from the mobile station across the radio interface.

- QoS Profile. This reports the (peak) bit rate, the precedence used at radio access and the transmission mode used across the radio path. The type of the BSSGP SDU, layer 3 signalling or data, and the type of LLC frame, SACK, ACK, or not, are not meaningful on the uplink and shall be ignored.

In order to support location based services, the BSS shall include the cell identifier of the cell upon which the LLC-PDU was received.

In addition to constructing the UL-UNITDATA, the BSS supplies the LSP, the NSEI and the BVCI associated with the MS to the lower layer network service, enabling network service routing to the peer entity. These parameters are not transmitted as part of the BSSGP across the Gb-interface.

### 6.2.1 Abnormal conditions

None specified.

## 6.3 RA-CAPABILITY procedure

The SGSN stores an MS's current radio access capability (which may be changed by higher layer mobility management procedures). An MS's current radio access capability, and the TLLI identifying the MS, are conveyed to a BSS in a RA-CAPABILITY PDU. The received MS's radio access capability, if valid, shall then replace any radio access capability previously associated with the MS.

### 6.3.1 Abnormal conditions

If the BSS receives an unknown Access Technology Type in the MS Radio Access Capability field, it shall ignore the fields associated with that Access Technology type.

If the BSS receives unknown fields within a known Access Technology Type in the MS Radio Access Capability field, it shall ignore the unknown fields.

---

## 7 Signalling procedures between GMM SAPs

### 7.1 Paging procedure

When an SGSN initiates the paging procedure for GPRS services as defined in GSM 04.08 [11], it shall send one or more PAGING-PS PDUs to the BSS.

When instructed by an MSC/VLR to initiate a paging procedure for non-GPRS services as defined in GSM 04.08 [11], an SGSN shall send one or more PAGING-CS PDUs to the BSS.

These paging PDUs shall contain the information elements necessary for the BSS to initiate paging for an MS within a group of cells.

The SGSN provides an indication of the cells within which the BSS shall page the MS. The levels of resolution within one BSS are: all cells within the BSS, all cells on the BSS within one location area, all cells on the BSS within one routing area, and one BVCI (i.e. cell). A routing area, a location area, or a BSS area is associated with one or more NSEIs. If the cells in which to page the MS are served by several NSEIs then one paging PDU must be sent to each of these NSEIs.

A paging PDU shall be used to generate the corresponding radio interface paging request message(s) to be transmitted at the appropriate time.

It should be noted that each paging PDU relates to only one MS and therefore a BSS may pack pages for different MSs into the relevant GSM 04.08 [11] or GSM 04.60 [3] radio interface paging request messages.

In the case of paging for non-GPRS services, the SGSN shall provide the MS's IMSI and DRX Parameters.

In the case of paging for GPRS services, the SGSN shall provide the MS's IMSI. If DRX Parameters are available, the SGSN shall also provide the DRX Parameters.

**NOTE:** The IMSI and the DRX Parameters enable the BSS to derive the paging population number. Paging without DRX parameters may require a considerable extension of the paging duration.

An SGSN provides the BSSGP with MS specific information, enabling a BSS to execute the paging procedure in an MS specific manner. This includes:

- QoS Profile. The Precedence parameter is set by the upper layers [in the SGSN]. The SGSN shall set the bit rate parameter to "best effort". The SGSN shall set the transmission mode to unacknowledged. The BSS shall ignore the received bit rate, the BSSGP SDU type, LLC type, and transmission mode parameters.

If an SGSN provides a P-TMSI in a PAGING-PS PDU, then the BSS shall use the P-TMSI to address the MS. If the SGSN does not provide the P-TMSI in the PAGING-PS PDU, then the BSS shall use the IMSI to address the MS. Therefore, the SGSN shall not provide the P-TMSI if it wants to page the MS with the IMSI.

If an SGSN provides a TLLI in a PAGING-CS PDU and a radio context identified by the TLLI exists within the BSS, then the paging request message shall be directly sent to the MS. If the SGSN does not provide the TLLI in the PAGING-CS PDU or if no radio context identified by the TLLI exists within the BSS, then the BSS shall use the TMSI, if provided in the PAGING-CS PDU, else the IMSI, to address the MS.

The PAGING-CS PDU consists of the parameters described above for a PAGING-PS PDU (except the P-TMSI and QoS profile parameters) and, optionally, some or all of the following parameters; TMSI, TLLI, Channel Needed and eMLPP-Priority. The Channel Needed and eMLPP-Priority information shall be handled transparently by the BSS.

## 7.2 Radio Access Capability Update procedure

The BSS may request an MS's current Radio Access capability by sending to an SGSN a RA-CAPABILITY-UPDATE PDU which includes the TLLI of the MS and a Tag. The allocation of the Tag is implementation specific. The BSS then starts timer T5.

The SGSN shall respond by sending a RA-CAPABILITY-UPDATE-ACK PDU which includes the TLLI of the MS, the Tag received in the corresponding RA-CAPABILITY-UPDATE PDU, and an RA-Cap-UPD-Cause field. The BSS shall stop timer T5.

If the RA-Cap-UPD-Cause is set to "OK", then a MS Radio Access Capability field shall be present. The received MS's radio access capability, if valid, shall then replace any radio access capability previously associated with the MS. If the RA-Cap-UPD-Cause is not set to "OK", then the MS Radio Access Capability shall not be present in the RA-CAPABILITY-UPDATE-ACK PDU.

### 7.2.1 Abnormal conditions

If an SGSN receives a RA-CAPABILITY-UPDATE PDU which includes an unknown TLLI, it shall answer with a RA-CAPABILITY-UPDATE-ACK PDU which includes the RA-CAP-UPD-Cause set to the value "TLLI unknown".

If an SGSN receives a RA-CAPABILITY-UPDATE PDU which includes a known TLLI, but there are no Radio Access parameters known to the SGSN for the associated MS, the SGSN shall reply to the request with a RA-CAPABILITY-UPDATE-ACK PDU in which the RA-CAP-UPD-Cause is set to: "no RA capability available".

If a BSS receives a RA-CAPABILITY-UPDATE-ACK PDU containing a Tag which is different from the last transmitted Tag by the BSS, it shall ignore the reception of this PDU.

If a BSS sends a RA-CAPABILITY-UPDATE PDU to an SGSN and the RA-CAPABILITY-UPDATE-ACK is not returned within a period T5 with the same Tag value as provided in the request, the RA-CAPABILITY-UPDATE procedure shall be repeated a maximum of RA-CAPABILITY-UPDATE-RETRIES attempts. The Tag value shall be changed by the BSS at each new retry.

## 7.3 Radio Status procedure

A BSS and an MS radio interface communication may not be successfully completed as requested because:

- 1) the MS goes out of coverage and is lost;  
This condition is signalled by setting the Radio Cause value to "Radio contact lost with MS".
- 2) the link quality is too bad to continue the communication;  
This condition is signalled by setting the Radio Cause value to "Radio link quality insufficient to continue communication".
- 3) the BSS has ordered the MS to perform a cell-reselection.  
This condition is signalled by setting the Radio Cause value to "cell-reselection ordered".

Conditions 1) and 2) indicate that attempts to communicate between an MS and an SGSN via this cell should be suspended or abandoned. An SGSN shall stop sending LLC-PDUs to the cell for the MS. The criteria for deciding whether condition 1) or 2) has occurred is not in the scope of GSM 08.18.

The conditions for resuming a suspended or abandoned communication between an MS and SGSN are defined in GSM 04.08 [11].

Condition 3) indicates that the SGSN should wait for a cell update before resuming the transmission of LLC-PDUs to the BSS.

A BSS shall signal these exception conditions to an SGSN by sending a RADIO-STATUS PDU. It shall contain a reference to the MS, either TLLI or TMSI or IMSI, and an indication of the exception condition, i.e. the Radio Cause value.



## 7.4 SUSPEND procedure

If the MS signals to the BSS that it wishes its GPRS service to be suspended, the BSS shall send a SUSPEND PDU to the SGSN and start timer T3. Actions within the SGSN while an MS is suspend are not specified, but paging is typically stopped. The SUSPEND PDU contains:

- the TLLI of the MS; and
- the Routeing Area of the MS.

For each SUSPEND PDU received by an SGSN, a SUSPEND-ACK PDU shall be returned to the BSS. Upon reception of the SUSPEND-ACK PDU, the BSS shall stop T3. The SUSPEND-ACK PDU contains:

- the TLLI of the MS;
- the Routeing Area of the MS; and
- the Suspend Reference Number.

The SGSN generates the Suspend Reference Number in a manner that it enables it to differentiate between different SUSPEND PDUs relating to the same MS.

### 7.4.1 Abnormal conditions

If a SUSPEND-ACK PDU is not received for a SUSPEND PDU within T3 seconds, then the SUSPEND PDU procedure shall be repeated a maximum of SUSPEND-RETRIES attempts. After SUSPEND-RETRIES attempts the procedure is stopped and the O&M system is informed.

If a SUSPEND-ACK PDU is received for an MS that is already marked as suspended, then the SUSPEND-ACK PDU is ignored.

If a SUSPEND PDU refers to an MS which is unknown in the SGSN, then a SUSPEND-NACK PDU is returned containing a cause value (Cause value: Unknown MS). The BSS shall stop the SUSPEND procedure.

## 7.5 RESUME procedure

When a GPRS-attached MS leaves dedicated mode, disconnecting the MS from the MSC, the BSS shall either a) instruct the MS to initiate the Routeing Area Update procedure, or b) signal to the SGSN that an MS's GPRS service shall be resumed.

If the BSS executes a), then no further action is required.

If the BSS executes b), then the BSS shall send a RESUME PDU containing the same Suspend Reference Number received in the SUSPEND-ACK PDU to the SGSN and start timer T4. The RESUME PDU contains:

- the TLLI of the MS;
- the Routeing Area of the MS; and
- the Suspend Reference Number.

For each RESUME PDU received by an SGSN, a RESUME-ACK PDU shall be returned to the BSS. Upon reception of the RESUME-ACK PDU, the BSS shall stop T4. The RESUME-ACK PDU contains:

- the TLLI of the MS; and
- the Routeing Area of the MS.

## 7.5.1 Abnormal conditions

If a RESUME-ACK PDU is not received for a RESUME PDU within T4 seconds, then the RESUME PDU procedure shall be repeated a maximum of RESUME-RETRIES attempts. After RESUME-RETRIES attempts the procedure is stopped, the O&M system is informed and the MS shall be instructed to initiate the Routing Area Update procedure.

If a RESUME-ACK PDU is received for an MS that is not suspended, then the RESUME-ACK PDU is ignored.

If a RESUME PDU refers to an MS which is unknown in the SGSN, then a RESUME-NACK PDU is returned containing a cause value (Cause value: Unknown MS). The BSS shall stop the RESUME procedure and the MS shall be instructed to initiate the Routing Area Update procedure.

---

# 8 Signalling procedures between NM SAPs

## 8.1 FLUSH-LL (logical link) procedure

When an SGSN detects a cell change of an MS from a cell update or a routing area update, the SGSN shall send a FLUSH-LL PDU to the old BVC to initiate the following procedures:

- at a cell change within one NSE (e.g. the BSS is a NSE) and within one routing area, LLC-PDU(s) for a given TLLI stored at an "old" BVC (corresponding to the old cell) are either deleted or transferred to a "new" BVC (corresponding to the new cell) with which the TLLI is currently associated; or
- at a cell change between two NSEs or between two routing areas, LLC-PDU(s) stored at the "old" BVC for the TLLI are deleted.

The SGSN provides the BSSGP with:

- a MS's TLLI identifying the MS;
- the "old" BVC identifying the cell in which to find buffered LLC-PDU(s) for the MS; and
- the "new" BVC identifying the cell to which the MS is currently associated (only when within the same NSE and within the same routing area).

If a "new" BVC is not provided, then the FLUSH-LL PDU shall be interpreted as an instruction to delete the queued LLC-PDU(s) at the old BVC.

Queued BSSGP signalling, e.g. pages, shall not be affected by this procedure.

In response to a FLUSH-LL PDU the BSS shall send a FLUSH-LL-ACK PDU to the SGSN containing:

- the TLLI received in the FLUSH-LL PDU; and
- an indication of whether the LLC-PDU(s) were "transferred" (when in the same NSE) or "deleted". In case the SDUs were "transferred" the BVC (new) IE shall be included.

On receipt of a FLUSH-LL-ACK PDU by the SGSN, indicating that the LLC-PDU(s) associated with the old BVC have been "deleted", the SGSN may choose to:

- immediately re-transmit all un-acknowledged LLC-PDU(s) (in acknowledged LLC operation) to the MS at the new BVC (ie new cell); or
- relay on LLC retransmission mechanism to transmit un-acknowledged LLC-PDU(s).

On receipt of a FLUSH-LL-ACK PDU by the SGSN, indicating that the LLC-PDU(s) associated with the old BVC have been "transferred" within the NSE, the SGSN shall not take any of the above actions.

## 8.1.1 Abnormal Conditions

If the BSS receives a FLUSH-LL PDU for an unknown BVCI or TLLI not associated with the given BVCI, then the FLUSH-LL PDU is discarded and no FLUSH-LL-ACK PDU is returned.

If the SGSN does not receive a FLUSH-LL-ACK PDU in response to a FLUSH-LL PDU, no further action is taken.

## 8.2 Flow Control procedure

### 8.2.1 General model of operation

From the perspective of the BSSGP, the flow control mechanism is based on the following model:

- there is a downlink buffer for each BVC, as identified by a BVCI, in a BSS;
- the transfer of BSSGP UNITDATA PDUs for an MS from the SGSN is controlled by the BSS; and
- only downlink BSSGP UNITDATA PDU transfer to the BSS is managed via flow control procedures. Uplink flow control is not performed.

### 8.2.2 Mode of operation

The flow control mechanism manages the transfer of BSSGP UNITDATA PDUs sent by the SGSN on the Gb interface to the BSS.

The BSS shall control the flow of BSSGP UNITDATA PDUs to its BVC buffers by indicating to the SGSN the maximum allowed throughput in total for each BVC. The BSS shall control the flow of BSSGP UNITDATA PDUs to the BVC buffer for an individual MS by indicating to the SGSN the maximum allowed throughput for a certain TLLI.

The BSS uses flow control to adjust the flow of BSSGP UNITDATA PDUs to a BVC buffer. The amount of buffered BSSGP UNITDATA PDUs in the BSS should be optimised to efficiently use the available radio resource. The volume of buffered BSSGP UNITDATA PDUs for a BVC or MS should be low. BSSGP UNITDATA PDUs queued within the BSS that are not transferred across the radio interface before the PDU Lifetime expires shall be locally deleted from the BSS. The local deletion of BSSGP UNITDATA PDUs in the BSS shall be signalled to the SGSN by the transmission of a LLC-DISCARDED PDU.

For each FLOW-CONTROL PDU received by an SGSN, a confirmation shall always be sent across the Gb interface by the SGSN. The confirmation uses the Tag that was received in the FLOW-CONTROL PDU, which was set by the BSS to associate the response with the request. When receiving no confirmation to a FLOW-CONTROL PDU, the reasons that gave rise to the triggering of a flow control message may trigger another message, or, if the condition disappears, it may not. For the repetition of non-confirmed FLOW CONTROL PDUs, the maximum repetition rate still applies in the BSS.

### 8.2.3 Flow Control of Traffic from an SGSN to BSS

#### 8.2.3.1 Control of the downlink throughput by the SGSN

The principle of the BSSGP flow control procedures is that the BSS sends to the SGSN flow control parameters which allow the SGSN to locally control its transmission output in the SGSN to BSS direction. The SGSN shall perform flow control on each BVC and on each MS. The flow control is performed on each LLC-PDU first by the MS flow control mechanism and then by the BVC flow control mechanism. If the LLC-PDU is passed by the individual MS flow control, the SGSN then applies the BVC flow control to the LLC-PDU. If an LLC-PDU is passed by both flow control mechanisms, the entire LLC-PDU is delivered to the Network Services for transmission to the BSS (see figure 8.1).

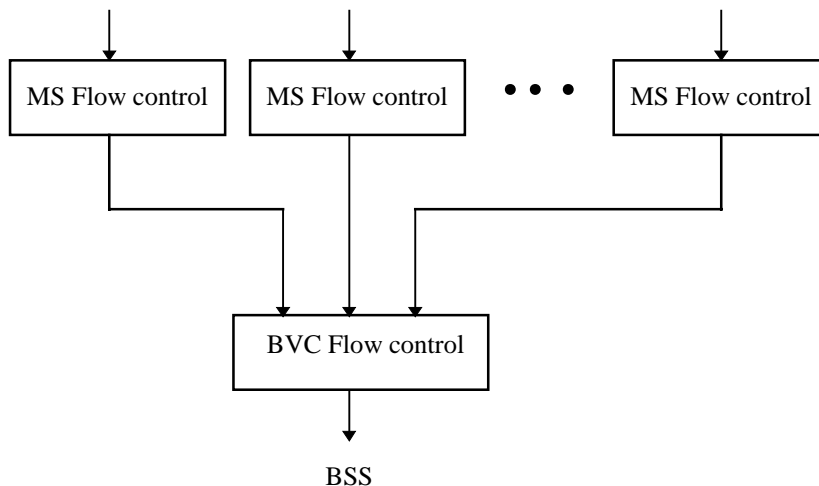

**Figure 8.1: BVC Flow control**

The flow control parameters sent by the BSS to the SGSN consist of the following information:

- the bucket size ( $B_{max}$ ) for a given BVC or MS in the downlink direction; and
- the bucket leak rate ( $R$ ) for a given BVC or MS in the downlink direction.

The SGSN shall perform flow control on an individual MS using SGSN determined values of  $B_{max}$  and  $R$  unless it receives a FLOW-CONTROL-MS message from the BSS regarding that MS. The SGSN shall continue to perform flow control for a particular MS using the  $B_{max}$  and  $R$  values received from the BSS for at least  $T_h$  seconds after receiving a FLOW-CONTROL-MS message from the BSS regarding that MS. When timer  $T_h$  has expired or when the MS changes cells, the SGSN may reinitialise the SGSN internal flow control variables for that MS and begin to use SGSN generated values for  $B_{max}$  and  $R$ .

The BSSGP flow control model is the algorithm shown in figure 8.2. The model of the algorithm is that an LLC-PDU is passed by the algorithm as long as the bucket counter ( $B$ ) plus the length of the LLC-PDU does not exceed the bucket size  $B_{max}$ . When the LLC-PDU is passed, the LLC-PDU length is added to  $B$ . Any PDU not transmitted is delayed until  $B$  plus the LLC-PDU length is less than  $B_{max}$ .

### 8.2.3.2 Flow Control Conformance Definition

A BSSGP flow control algorithm shall be implemented in the SGSN. The BSSGP flow control conformance algorithm is defined in figure 8.2.

The conformance definition is used to decide which LLC-PDUs are conforming to the flow to an MS or in a BSSGP virtual connection (BVC) over the Gb interface. The conformance definition should not be interpreted as the required implementation algorithm, as the SGSN manufacturer may use any algorithm as long as the operation of the BSSGP flow control does not violate the objectives of compliant BVCs or MSs. That is, the SGSN shall never transmit more data than can be accommodated within the BSS buffer for a BVC or individual MS.

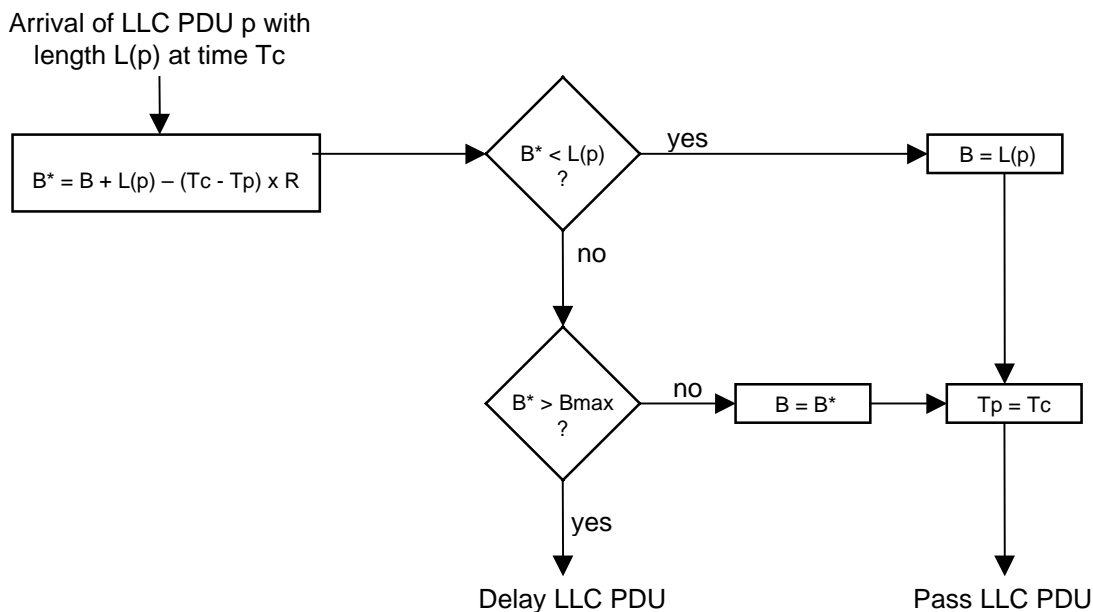

**Figure 8.2: Conformance Definition Algorithm for BSSGP Flow Control**

The variables used by the algorithm are:

- Bmax Bucket Size. Set by the BSS for each cell and each mobile station. Bmax shall be large enough to accommodate at least one LLC-PDU;
- R leak rate of the bucket;
- B bucket counter;
- B\* predicted value of the bucket counter;
- L(p) length of LLC-PDU p;
- Tp the time that the last LLC-PDU p was transferred; and
- Tc arrival time of LLC-PDU p.

The initial conditions of these variables in the SGSN are:

- Bmax = 0. For BVCs, this value is valid until Bmax is received in the Flow Control-BVC. For MSs, this value is valid until Bmax\_default\_MS is received in the Flow-Control-BVC message. Thereafter, subclause “Condition of Bmax for MS after Initial Flow-Control-BVC”, shall apply;
- R = 0. For a BVC, this value is valid until a Flow-Control-BVC message is received. For an MS, this value is valid until a Flow-Control-BVC message is received. Thereafter, subclause “Condition of Bmax for MS after Initial Flow-Control-BVC”, shall apply;
- B = 0 (the bucket is empty); and  $\tilde{T}_p$  = the current time for the first LLC-PDU.

The SGSN shall not transmit a LLC-PDU on a BVC until a Flow-Control-BVC message is received from the BSS for that BVC.

When a LLC-PDU p arrives at current time Tc, the variable B\* is set to the predicted bucket size if the LLC-PDU were to be transferred to the BSS. This is given by the previous bucket size plus the new LLC-PDU size,  $B^* = B + L(p)$ , less the amount that the bucket will have leaked away since the last compliant LLC-PDU,  $R * (Tc - Tp)$ . If this is less than L(p) then the LLC-PDU is compliant and the bucket size B is reset to L(p) and the LLC-PDU is passed. When a compliant LLC-PDU is passed the last LLC-PDU transfer time is set to the current time,  $T_p = T_c$ .

If the bucket has not completely leaked away then the bucket has to be checked to see if the limit  $B_{max}$  is going to be exceeded,  $B^* > B_{max}$ . If the limit is exceeded then the LLC-PDU is non compliant and is delayed for some time period, and no updates are done on the variables. If the bucket limit  $B_{max}$  is not exceeded then the LLC-PDU is compliant and the bucket counter ( $B$ ) is set equal to the value of  $B^*$ . When a conforming LLC-PDU is passed then the last LLC-PDU transfer time is set to the current time,  $T_p = T_c$ .

On receipt of a FLUSH-LL-ACK PDU by the SGSN, indicating that the LLC-PDU(s) associated with the old BVC have been “deleted”, the SGSN should update the value of the bucket counter ( $B$ ) for the MS and for the old BVC,  $B = \max(B - N, 0)$ .  $N$  is provided by FLUSH-LL-ACK PDU, indicating the number of octets deleted by the BSS.

On receipt of a FLUSH-LL-ACK PDU by the SGSN, indicating that the LLC-PDU(s) associated with the old BVC have been “transferred” within the NSE, the SGSN should update the value of the bucket counter ( $B$ ) for the old BVC,  $B = \max(B - N, 0)$ . The value of  $B$  for the new BVC should also be updated,  $B = \min(B + N, B_{max})$ .  $N$  is provided by FLUSH-LL-ACK PDU, indicating the number of octets transferred by the BSS.

On receipt of a LLC-DISCARDED PDU by the SGSN, indicating that the LLC-PDU(s) associated with the MS have been locally deleted by the BSS, the SGSN should update the value of the bucket counter ( $B$ ) for the MS and for the BVC,  $B = \max(B - N, 0)$ .  $N$  is provided by LLC-DISCARDED PDU, indicating the number of octets deleted by the BSS.

The BSS may update the values of  $B_{max}$  and  $R$  within the SGSN at any time by transmitting a new Flow Control PDU containing the new  $B_{max}$  and  $R$  values. The variables  $B$ ,  $B^*$ ,  $T_p$  and  $T_c$  are local to the SGSN and are not affected by the reception of a Flow-Control-BVC or Flow Control-MS PDU.

### 8.2.3.3 Response time within the SGSN to flow control messages

Upon reception of flow control requests from a BSS, the SGSN shall modify its downlink transmission as instructed within 100 ms.

### 8.2.3.4 Frequency of sending BVC or MS Flow Control PDUs

The rate at which the BSS is allowed to send flow control messages for a given BVC or MS is limited and defined by the following rule: the BSS may send a new Flow Control PDU every  $C$  seconds, where  $C$  is a value which is pre-defined and common to the BSS and SGSN.

If the BSS detects a missing FLOW-CONTROL-ACK from the SGSN and the condition which causes the sending of a FLOW-CONTROL PDU still remains, the FLOW-CONTROL PDU may be retransmitted immediately. In this case the BSS may violate the repetition rate defined by the  $C$  value.

### 8.2.3.5 FLOW-CONTROL PDUs

Based on the criteria for flow control, a BSS shall send to an SGSN a FLOW-CONTROL PDU containing a list of IEs.

For BVC Flow Control, the following information is sent:

- the maximum bucket size ( $B_{max}$ ) for the BVC on the Gb Interface;
- the leak rate parameter ( $R$ ) to be applied to the bucket;
- the default MS bucket size ( $B_{max\_default\_MS}$ );
- the default MS leak rate ( $R\_default\_MS$ ); and
- the optional measurement of the delay for PDU delivery inside that BVC.

For MS Flow Control, the following information is sent:

- the TLLI identifying the MS;
- the maximum bucket size ( $B_{max}$ ) for this MS on the Gb interface; and
- the leak rate parameter ( $R$ ) to be applied to the bucket.

### 8.2.3.6 Condition of Bmax for MS after Initial Flow-Control-BVC

The SGSN may use the following (informative) equation to generate an initial bucket size, Bmax, for an MS.

$$B_{\max} \text{ (bits)} = \min \left( R_{\text{default\_MS for 1 sec}}, 72000, \text{max MS throughput for 1 sec}, \frac{\text{(max MS throughput for 1 sec + current throughput of all other MSs in the cell for 1 sec)}}{\text{number of MSs in the cell}} \right)$$

where, the number of MSs in the cell includes the MS being added.

Under no circumstance shall the SGSN use a value of Bmax greater than Bmax\_default\_MS for an MS unless it receives a Flow-Control-MS message from the BSS for that MS.

The SGSN shall not use a leak rate (R) for an MS greater than R\_default\_MS unless it receives a Flow-Control-MS message from the BSS for that MS.

## 8.2.4 Flow Control of Uplink Traffic from a BSS to an SGSN

No flow control procedures are defined between the BSS and the SGSN in uplink direction.

## 8.3 BVC blocking and unblocking procedure

### 8.3.1 PTP BVC

The following statement applies only for PTP BVC.

The BVC blocking and unblocking procedures are initiated by the BSS to remove from use, or bring in to use, a BVC.

A BSS may block one BVC because of:

- Operation and Maintenance intervention for a cell;
- equipment failure at the BSS;
- cell equipment failure at the BSS; or
- other causes not regarded in phase 1 of the implementation of GPRS (Cause Value: "reserved for future use").

When a BSS wishes to block a BVC, the BSS shall mark that BVC as blocked, thereafter discarding any traffic sent to the BVC in the uplink direction. The cell associated with the BVC should not accept data in the downlink direction. The BSS shall send a BVC-BLOCK PDU to the SGSN and start timer T1. The BVC-BLOCK PDU contains:

- the BVCI of the BVC to be blocked; and
- a Cause element indicating the reason for blocking (typical cause values: O&M intervention, Equipment failure).

On receipt of a BVC-BLOCK PDU, the SGSN shall mark the indicated BVC as blocked and stop transmitting traffic addressed to this BVC. The SGSN shall then acknowledge the blocking of the BVC by sending a BVC-BLOCK-ACK PDU to the BSS.

The BVC-BLOCK-ACK PDU contains the BVCI received in the BVC-BLOCK PDU.

On receipt of the BVC-BLOCK-ACK PDU the BSS shall stop timer T1.

The BVC shall be seen as blocked by an SGSN until a BVC-UNBLOCK PDU is received indicating that the BVC's status has changed.

During the BVC blocking procedure, traffic in transit to or from a cell is in an indetermined state and may be lost. When unblocking a BVC both the BSS and SGSN shall be in an operational state, i.e. the underlying network service and the BVC shall be available for use.

If a BSS wishes to unblock a blocked BVC it shall send a BVC-UNBLOCK PDU, and start timer T1.

The BVC-UNBLOCK PDU contains:

- the BVCI of the BVC to be unblocked.

If a BVC-UNBLOCK PDU is received by an SGSN for a blocked BVC, the BVC shall be marked as unblocked and a BVC-UNBLOCK-ACK PDU shall be returned to the BSS, containing the BVCI received in the BVC-UNBLOCK PDU.

The BSS shall stop timer T1 on receipt of the BVC-UNBLOCK-ACK PDU and mark the BVC as unblocked.

### 8.3.2 Signalling BVC

The blocking and unblocking procedure is not applicable for the signalling BVC. The signalling BVC shall never be blocked.

### 8.3.3 Abnormal Conditions

The following statements apply only for a signalling BVC.

If a BVC-BLOCK PDU is received by an SGSN for the signalling BVC, the PDU is ignored.

If a BVC-BLOCK-ACK PDU is received by a BSS for the signalling BVC, the PDU is ignored.

If BVC-UNBLOCK PDU is received by an SGSN for the signalling BVC, the PDU is ignored.

If BVC-UNBLOCK-ACK PDU is received by an BSS for the signalling BVC, the PDU is ignored.

The following statements apply only for PTP BVC.

If a BVC-BLOCK-ACK PDU is not received for a BVC-BLOCK PDU within T1 seconds, then the BVC-BLOCK PDU procedure shall be repeated a maximum of BVC-BLOCK-RETRIES attempts. After BVC-BLOCK-RETRIES attempts the BVC remains blocked, the procedure is stopped and the O&M system is informed.

If a BVC-UNBLOCK-ACK PDU is not received for a BVC-UNBLOCK PDU within T1 seconds, then the BVC-UNBLOCK PDU procedure shall be repeated a maximum of BVC-UNBLOCK-RETRIES attempts. After BVC-UNBLOCK-RETRIES attempts the status of the BVC remains blocked, the procedure is stopped and the O&M system is informed.

If traffic is received on a BVC that is marked at a BSS or at an SGSN as blocked, and no BVC-Unblocking procedure is pending, the received PDU shall not be accepted and a STATUS PDU (Cause value: BVC blocked) shall be sent to the peer entity on the signalling BVC. The STATUS PDU shall indicate the BVCI of the BVC upon which the error was detected.

If a BVC-BLOCK PDU is received by an SGSN for a blocked BVC, a BVC-BLOCK-ACK PDU shall be returned.

If a BVC-UNBLOCK PDU is received by an SGSN for an unblocked BVC, a BVC-UNBLOCK-ACK PDU shall be returned.

If an unexpected BVC-BLOCK-ACK PDU is received by a BSS, and it is related to a BVC that is locally blocked, the BVC-BLOCK-ACK PDU is discarded. If the BVC-BLOCK-ACK PDU is related to a BVC that is not locally blocked, then a BVC unblock procedure shall be performed.

If an unexpected BVC-UNBLOCK-ACK PDU is received by a BSS and it is related to a BVC that is locally not blocked, the BVC-UNBLOCK-ACK PDU is discarded. If the BVC-UNBLOCK-ACK PDU is related to a BVC that is locally blocked, then a BVC block procedure shall be performed.

## 8.4 BVC-RESET procedure

The purpose of the BVC-RESET procedure is to synchronise the initialisation of GPRS BVC related contexts at a BSS and SGSN. This enables the BSS and SGSN to begin communication in known states. A BVC-RESET procedure is performed because of recovery procedures related to:

- a system failure in the SGSN or BSS that affects GPRS BVC functionality (e.g. processor recovery);



- an underlying network service system failure; or
- a change in the transmission capability of the underlying network service, where the “change” is from zero kbps to greater-than-zero kbps;
- a change in mapping between the BVCI and cell identifier.

The BSS may also send BVC-RESET as a means to create the initial mapping between BVCI and cell identifications.

After any of the possible events stated above, the status of the affected BVCs may be inconsistent at the SGSN and the BSS. After performing the BVC Reset procedure all affected BVCs are assumed to be unblocked at the SGSN. The reset procedure forces a consistent state upon SGSN and BSS by requiring that after the completion of the BVC-Reset procedure the BSS initiates the block procedure for all affected BVCs that are marked as blocked at the BSS.

Before a BSS (or SGSN) sends a BVC-RESET PDU, the operational status of the associated network service shall be obtained by the BSS (or SGSN).

If the associated network service is operational, the BSS (or SGSN) shall send a BVC-RESET PDU to its peer entity and start timer T2. The BSS (or SGSN) may receive BVC related signalling and UNITDATA PDUs before the procedure is acknowledged, but shall not transmit PDUs.

If the associated network service is not operational, the BVC-RESET procedure is postponed until internal periodic status checks indicate that it is operational.

The BVC-RESET PDU contains:

- the BVCI of the reset BVC;
- a cause element indicating the reason for reset;
- the cell identifier, when the reset is for a PTP BVC and BSS is initiator of the reset.

After the SGSN (or BSS) has initialised all affected GPRS related contexts, a BVC-RESET-ACK PDU is returned.

The BVC-RESET-ACK PDU contains:

- the BVCI of the reset BVC;
- the cell identifier, when the reset is for a PTP BVC and SGSN is initiator of the reset.

Upon reception by a BSS (or SGSN) of the BVC-RESET-ACK PDU the timer T2 is stopped.

### 8.4.1 Signalling BVC

After any failure affecting the NSE, the party (BSS or SGSN) where the failure resided shall reset the signalling BVC. After sending or receiving a BVC-RESET PDU for the signalling BVC, the BSS shall stop all traffic and initiate the BVC-RESET procedure for all BVCs corresponding to PTP functional entities of the underlying network service entity. The BSS must complete the BVC-RESET procedure for signalling BVC before starting PTP BVC-RESET procedures.

After sending or receiving a BVC-RESET PDU for the signalling BVC, the SGSN shall stop all traffic in the PTP BVCs of the corresponding NSE.

### 8.4.2 PTP BVC

After any failure affecting only part of the BVC functionality not including the signalling BVC the party where the failure resided shall reset only the affected BVCs.

If the BSS was the initiator of the BVC-RESET procedure, the BSS may initiate the blocking procedure without waiting for a BVC-RESET-ACK PDU. If the SGSN was the initiator of the BVC-RESET procedure, the BSS shall initiate the BVC-Blocking procedure after returning the BVC-RESET-ACK PDU to the SGSN.

Upon reception of a BVC-RESET PDU, the SGSN (or BSS) shall discard UNITDATA PDUs addressed to the reset BVC.

After reset of a PTP BVC, UNITDATA PDUs addressed to the BVC may then be received and transmitted, unless it is blocked.

### 8.4.3 Abnormal Conditions

The following statements are valid for both signalling and PTP BVC.

If a BSS (or SGSN) sends a BVC-RESET PDU to an SGSN (or BSS) and the BVC-RESET-ACK PDU is not returned within a period T2, the BVC-RESET procedure shall be repeated a maximum of BVC-RESET-RETRIES attempts. After BVC-RESET-RETRIES attempts the procedure is stopped and the O&M system is informed. In case of PTP BVC, the status of all affected BVCs at the BSS (or SGSN) shall be blocked as a consequence.

If the BSS receives a BVC-RESET PDU for a BVCI which is unknown in the BSS then the BSS shall return a STATUS PDU towards the SGSN including the BVCI and the cause value 'BVCI unknown'.

If the BSS (or SGSN) has sent a BVC-RESET PDU for a BVCI to the SGSN (or BSS) and is awaiting a BVC-RESET-ACK PDU in response, but instead receives a BVC-RESET PDU indicating the same BVCI, then this shall be interpreted as an BVC-RESET ACK PDU and the T2 timer shall be stopped.

The BVC\_RESET for signalling BVC overrides all pending procedures for PTP BVC, i.e. other pending procedures are stopped and corresponding running timers are stopped.

If the BSS (or SGSN) receives an unexpected BVC-RESET ACK PDU, this shall be ignored.

## 8.5 Trace procedure

The purpose of the trace invocation procedure is to inform the receiving entity that it should begin producing a trace record on an MS. The trace is invoked by an SGSN by sending an SGSN-INVOKE-TRACE PDU to the peer entity. The SGSN-INVOKE-TRACE PDU is not acknowledged.

The events and parameters to be recorded are indicated in the "Trace type" information element are defined in GSM 12.08 [19].

The remaining elements, when received, are to be passed transparently to the OMC receiving the trace record.

The element "OMCId", if present, indicates the OMC to which the record is destined.

The PDU includes a trace reference which is allocated by the entity which triggered the trace.

The element "TriggerId", if present, indicates the entity which triggered the trace.

The Trace Reference and TriggerId IEs are used to tag the trace record to allow simpler construction of the total record by the entity which combines trace records.

---

## 9 General Protocol Error Handling

Refer to General Protocol Error Handling/GSM 08.16 [16]. In addition:

- any type of BSSGP PDU received without an expected conditional IE is discarded and a STATUS PDU (cause "Missing conditional IE") is sent;
- any type of BSSGP PDU received without a mandatory IE is discarded and a STATUS PDU (cause "Missing mandatory IE") is sent;
- any type of BSSGP PDU received with a syntactical error in an expected conditional IE is discarded and a STATUS PDU (cause "Conditional IE error") is sent;
- any type of BSSGP PDU received with a syntactical error in a mandatory IE is discarded and a STATUS PDU (cause "Invalid mandatory information") is sent.

Some BSSGP PDU shall contain one and only one conditional IE amongst a defined list of possible conditional IE (e.g. PAGING-PS PDU). If such a BSSGP PDU is received with more than one conditional IE amongst the defined list of possible conditional IE, as defined in section 10, the PDU is discarded and a STATUS PDU (cause “Unexpected conditional IE”) is sent.

## 10 PDU functional definitions and contents

### 10.1 General Structure Of A PDU

Refer to General Structure Of A PDU/GSM 08.16 [16].

### 10.2 PDU functional definitions and contents at RL and BSSGP SAPs

#### 10.2.1 DL-UNITDATA

This PDU is sent to the BSS to transfer an LLC-PDU across the radio interface to an MS.

PDU type: DL-UNITDATA

Direction: SGSN to BSS

**Table 10.1: DL-UNITDATA PDU contents**

Information element	Type / Reference	Presence	Format	Length
PDU type	PDU type/11.3.24	M	V	1
TLLI (current)	TLLI/11.3.33	M	V	4
QoS Profile	QoS Profile/11.3.26	M	V	3
PDU Lifetime	PDU Lifetime/11.3.23	M	TLV	4
MS Radio Access Capability a)	MS Radio Access Capability/11.3.20	O	TLV	7-15
Priority	Priority/11.3.25	O	TLV	3
DRX Parameters	DRX Parameters/11.3.11	O	TLV	4
IMSI	IMSI/11.3.14	O	TLV	5 -10
TLLI (old)	TLLI/11.3.33	O	TLV	6
Alignment octets	Alignment octets/11.3.1	O	TLV	2-5
LLC-PDU	LLC-PDU/11.3.15	M	TLV	3-?

- a) The field shall be present if there is valid MS Radio Access Capability information known by the SGSN ; the field shall not be present otherwise.

## 10.2.2 UL-UNITDATA

This PDU transfers an MS's LLC-PDU and its associated radio interface information across the Gb-interface.

PDU type: UL-UNITDATA

Direction: BSS to SGSN

**Table 10.2: UL-UNITDATA PDU content**

Information element	Type / Reference	Presence	Format	Length
PDU type	PDU type/11.3.24	M	V	1
TLLI	TLLI/11.3.33	M	V	4
QoS Profile	QoS Profile/11.3.26	M	V	3
Cell Identifier	Cell Identifier/11.3.9	M	TLV	10
Alignment octets	Alignment octets/11.3.1	O	TLV	2-5
LLC-PDU	LLC-PDU/11.3.15	M	TLV	3-?

## 10.2.3 RA-CAPABILITY

This PDU informs the BSS of the new Radio Access Capability of an MS.

PDU type: RA-CAPABILITY

Direction: SGSN to BSS

**Table 10.3: RA-CAPABILITY PDU content**

Information element	Type / Reference	Presence	Format	Length
PDU type	PDU type/11.3.24	M	V	1
TLLI	TLLI/11.3.33	M	TLV	6
MS Radio Access Capability	MS Radio Access Capability/11.3.20	M	TLV	7-15

## 10.2.4 PTM-UNITDATA

This shall be developed in GPRS phase 2.

## 10.3 PDU functional definitions and contents at GMM SAP

### 10.3.1 PAGING PS

This PDU indicates that a BSS shall initiate the packet paging procedure for an MS within a group of cells.

PDU type: PAGING PS

Direction: SGSN to BSS

**Table 10.4: PAGING PS PDU content**

Information elements	Type / Reference	Presence	Format	Length
PDU type	PDU type/11.3.24	M	V	1
IMSI	IMSI/11.3.14	M	TLV	5 -10
DRX Parameters	DRX Parameters/11.3.11	O	TLV	4
BVCI a)	BVCI/11.3.6	C	TLV	4
Location Area a)	Location Area/11.3.17	C	TLV	7
Routeing Area a)	Routeing Area/11.3.29	C	TLV	8
BSS Area Indication a)	BSS Area Indication/11.3.3	C	TLV	3
QoS Profile	QoS Profile/11.3.26	M	TLV	5
P-TMSI	TMSI/11.3.34	O	TLV	6

- a) One and only one of the conditional IEs shall be present. No repeated instances of the conditional IEs are permissible (e.g. one and only one Location Area shall be present).

### 10.3.2 PAGING CS

This PDU indicates that a BSS shall initiate a circuit-switched paging procedure for an MS within a group of cells.

PDU type: PAGING CS

Direction: SGSN to BSS

**Table 10.5: PAGING CS PDU content**

Information elements	Type / Reference	Presence	Format	Length
PDU type	PDU type/11.3.24	M	V	1
IMSI	IMSI/11.3.14	M	TLV	5 -10
DRX Parameters	DRX Parameters/11.3.11	M	TLV	4
BVCI a)	BVCI/11.3.6	C	TLV	4
Location Area a)	Location Area/11.3.17	C	TLV	7
Routeing Area a)	Routeing Area/11.3.29	C	TLV	8
BSS Area Indication a)	BSS Area Indication/11.3.3	C	TLV	3
TLLI	TLLI/11.3.33	O	TLV	6
Channel needed †	Channel needed/11.3.10	O	TLV	3
eMLPP-Priority †	eMLPP-Priority/11.3.12	O	TLV	3
TMSI †	TMSI/11.3.34	O	TLV	6

- a) One and only one of the conditional IEs shall be present. No repeated instances of the conditional IEs are permissible (e.g. one and only one Location Area shall be present).

NOTE: These fields are provided by the MSC via the Gs-Interface.

### 10.3.3 RA-CAPABILITY-UPDATE

This PDU requests that the SGSN sends an MS's current Radio Access capability to the BSS.

PDU type : RA-CAPABILITY-UPDATE

Direction : BSS to SGSN

**Table 10.6: RA-CAPABILITY-UPDATE PDU content**

Information element	Type / Reference	Presence	Format	Length
PDU type	PDU type/11.3.24	M	V	1
TLLI	TLLI/11.3.33	M	TLV	6
Tag	Tag/11.3.32	M	TLV	3

### 10.3.4 RA-CAPABILITY-UPDATE-ACK

This PDU provides the BSS with an MS's current Radio Access capability.

PDU type : RA-CAPABILITY-UPDATE-ACK

Direction : SGSN to BSS

**Table 10.7: RA-CAPABILITY-UPDATE-ACK PDU content**

Information element	Type / Reference	Presence	Format	Length
PDU type	PDU type/11.3.24	M	V	1
TLLI	TLLI/11.3.33	M	TLV	6
Tag	Tag/11.3.32	M	TLV	3
IMSI a)	IMSI/11.3.14	□	TLV	5-10
RA-Cap-UPD-CAUSE	RA-Cap-UPD-CAUSE/11.3.28	M	TLV	3
MS Radio Access Capability	MS Radio Access Capability/11.3.20	C	TLV	7-15

- a) If RA-Cap-UPD-CAUSE indicates failure of the RA-CAPABILITY-UPDATE procedure due to TLLI unknown in SGSN the IMSI IE will not be present.

### 10.3.5 RADIO-STATUS

This PDU indicates that an exception condition related to the radio interface has occurred.

PDU type: RADIO-STATUS

Direction: BSS to SGSN

**Table 10.8: RADIO STATUS PDU content**

Information elements	Type / Reference	Presence	Format	Length
PDU type	PDU type/11.3.24	M	V	1
TLLI a)	TLLI/11.3.33	C	TLV	6
TMSI a)	TMSI/11.3.34	C	TLV	6
IMSI a)	IMSI/11.3.14	C	TLV	5-10
Radio Cause	Radio Cause/11.3.27	M	TLV	3

- a) One and only one of the conditional IEs shall be present.

## 10.3.6 SUSPEND

This PDU indicates that an MS wishes to suspend its GPRS service.

PDU type: SUSPEND

Direction: BSS to SGSN

**Table 10.9: SUSPEND PDU content**

Information elements	Type / Reference	Presence	Format	Length
PDU type	PDU type/11.3.24	M	V	1
TLLI	TLLI/11.3.33	M	TLV	6
Routeing Area	Routeing Area/11.3.29	M	TLV	8

## 10.3.7 SUSPEND-ACK

This PDU positively acknowledges the reception of a SUSPEND PDU for an MS.

PDU type: SUSPEND-ACK

Direction: SGSN to BSS

**Table 10.10: SUSPEND-ACK PDU content**

Information elements	Type / Reference	Presence	Format	Length
PDU type	PDU type/11.3.24	M	V	1
TLLI	TLLI/11.3.33	M	TLV	6
Routeing Area	Routeing Area/11.3.29	M	TLV	8
Suspend Reference Number	Suspend Reference Number/11.3.31	M	TLV	3

## 10.3.8 SUSPEND-NACK

This PDU negatively acknowledges the reception of a SUSPEND PDU for an MS.

PDU type: SUSPEND-NACK

Direction: SGSN to BSS

**Table 10.11: SUSPEND-NACK PDU content**

Information elements	Type / Reference	Presence	Format	Length
PDU type	PDU type/11.3.24	M	V	1
TLLI	TLLI/11.3.33	M	TLV	6
Routeing Area	Routeing Area/11.3.29	M	TLV	8
Cause	Cause/11.3.8	O	TLV	3

### 10.3.9 RESUME

This PDU indicates that an MS wishes to RESUME its GPRS service.

PDU type: RESUME

Direction: BSS to SGSN

**Table 10.12: RESUME PDU content**

Information elements	Type / Reference	Presence	Format	Length
PDU type	PDU type/11.3.24	M	V	1
TLLI	TLLI/11.3.33	M	TLV	6
Routeing Area	Routeing Area/11.3.29	M	TLV	8
Suspend Reference Number	Suspend Reference Number/11.3.31	M	TLV	3

### 10.3.10 RESUME-ACK

This PDU positively acknowledges the reception of a RESUME PDU for an MS.

PDU type: RESUME-ACK

Direction: SGSN to BSS

**Table 10.13: RESUME-ACK PDU content**

Information elements	Type / Reference	Presence	Format	Length
PDU type	PDU type/11.3.24	M	V	1
TLLI	TLLI/11.3.33	M	TLV	6
Routeing Area	Routeing Area/11.3.29	M	TLV	8

### 10.3.11 RESUME-NACK

This PDU negatively acknowledges the reception of a RESUME PDU for an MS.

PDU type: RESUME-NACK

Direction: SGSN to BSS

**Table 10.14: RESUME-NACK PDU content**

Information elements	Type / Reference	Presence	Format	Length
PDU type	PDU type/11.3.24	M	V	1
TLLI	TLLI/11.3.33	M	TLV	6
Routeing Area	Routeing Area/11.3.29	M	TLV	8
Cause	Cause/11.3.8	O	TLV	3



## 10.4 PDU functional definitions and contents at NM SAP

### 10.4.1 FLUSH-LL

This PDU informs a BSS that an MS has moved from one cell to another.

PDU type: FLUSH-LL  
 Direction: SGSN to BSS

**Table 10.15: FLUSH LL PDU content**

Information elements	Type / Reference	Presence	Format	Length
PDU type	PDU type/11.3.24	M	V	1
TLLI	TLLI/11.3.33	M	TLV	6
BVCI (old)	BVCI/11.3.6	M	TLV	4
BVCI (new)	BVCI/11.3.6	O	TLV	4

### 10.4.2 FLUSH-LL-ACK

This PDU indicates that LLC-PDU(s) buffered for an MS in the old cell have been either deleted or transferred to the new cell within the NSE.

PDU type: FLUSH-LL-ACK  
 Direction: BSS to SGSN

**Table 10.16: FLUSH LL ACK PDU content**

Information elements	Type / Reference	Presence	Format	Length
PDU type	PDU type/11.3.24	M	V	1
TLLI	TLLI/11.3.33	M	TLV	6
Flush Action	Flush Action/11.3.13	M	TLV	3
BVCI (new)	BVCI/11.3.13	C 1)	TLV	4
Number of octets affected	Number of octets affected/11.3.39	M	TLV	5

1) BVCI (new) is included only if Flush action indicated that LLC-PDUs are transferred.

### 10.4.3 LLC-DISCARDED

This PDU indicates that a number of buffered LLC-PDUs in a cell for an MS have been deleted inside the BSS (because of PDU Lifetime expiration or Cell-reselection for example).

PDU type: LLC-DISCARDED  
 Direction: BSS to SGSN

**Table 10.17: LLC DISCARDED PDU content**

Information elements	Type / Reference	Presence	Format	Length
PDU type	PDU type/11.3.24	M	V	1
TLLI	TLLI/11.3.33	M	TLV	6
LLC Frames Discarded	LLC Frames Discarded/11.3.16	M	TLV	3
BVCI	BVCI/11.3.6	M	TLV	4
Number of octets deleted	Number of octets affected/11.3.39	M	TLV	5

## 10.4.4 FLOW-CONTROL-BVC

This PDU informs the flow control mechanism at an SGSN of the status of a BVC's maximum acceptable SGSN to BSS throughput on the Gb interface.

PDU type: FLOW-CONTROL-BVC

Direction: BSS to SGSN

**Table 10.18: FLOW-CONTROL-BVC PDU content**

Information elements	Type / Reference	Presence	Format	Length
PDU type	PDU type/11.3.24	M	V	1
Tag	Tag/11.3.32	M	TLV	3
BVC Bucket Size	BVC Bucket Size/11.3.5	M	TLV	4
Bucket Leak Rate	Bucket Leak Rate/11.3.4	M	TLV	4
Bmax default MS	Bmax default MS/11.3.2	M	TLV	4
R_default_MS	R_default_MS/11.3.30	M	TLV	4
BVC Measurement	BVC Measurement/11.3.7	O	TLV	4

## 10.4.5 FLOW-CONTROL-BVC-ACK

This PDU informs the flow control mechanism at the BSS that the SGSN has received the FLOW-CONTROL-BVC PDU indicated by the Tag.

PDU type: FLOW-CONTROL-BVC-ACK

Direction: SGSN to BSS

**Table 10.19: FLOW-CONTROL-BVC-ACK PDU content**

Information elements	Type / Reference	Presence	Format	Length
PDU type	PDU type/11.3.24	M	V	1
Tag	Tag/11.3.32	M	TLV	3

## 10.4.6 FLOW-CONTROL-MS

This PDU informs the flow control mechanism at an SGSN of the status of an MS's maximum acceptable SGSN to BSS throughput on the Gb interface.

PDU type: FLOW-CONTROL-MS

Direction: BSS to SGSN

**Table 10.20: FLOW-CONTROL-MS PDU content**

Information elements	Type / Reference	Presence	Format	Length
PDU type	PDU type/11.3.24	M	V	1
TLLI	TLLI/11.3.33	M	TLV	6
Tag	Tag/11.3.32	M	TLV	3
MS Bucket Size	MS Bucket Size/11.3.19	M	TLV	4
Bucket Leak rate	Bucket Leak rate/11.3.4	M	TLV	4

## 10.4.7 FLOW-CONTROL-MS-ACK

This PDU informs the flow control mechanism at the BSS that the SGSN has received the FLOW-CONTROL-MS PDU indicated by the TLLI and the Tag.

PDU type: FLOW-CONTROL-MS-ACK

Direction: SGSN to BSS

**Table 10.21: FLOW-CONTROL-MS-ACK PDU content**

Information elements	Type / Reference	Presence	Format	Length
PDU type	PDU type/11.3.24	M	V	1
TLLI	TLLI/11.3.33	M	TLV	6
Tag	Tag/11.3.32	M	TLV	3

## 10.4.8 BVC-BLOCK

This PDU indicates that the contained BVC shall be blocked at the recipient entity.

PDU type: BVC-BLOCK

Direction: BSS to SGSN

**Table 10.22: BVC-BLOCK PDU content**

Information elements	Type / Reference	Presence	Format	Length
PDU type	PDU type/11.3.24	M	V	1
BVCI	BVCI/11.3.6	M	TLV	4
Cause	Cause/11.3.8	M	TLV	3

## 10.4.9 BVC-BLOCK-ACK

This PDU acknowledges that a BVC has been blocked.

PDU type: BVC-BLOCK-ACK

Direction: SGSN to BSS

**Table 10.23: BVC-BLOCK-ACK PDU content**

Information elements	Type / Reference	Presence	Format	Length
PDU type	PDU type/11.3.24	M	V	1
BVCI	BVCI/11.3.6	M	TLV	4

## 10.4.10 BVC-UNBLOCK

This PDU indicates that the identified BVC shall be unblocked at the recipient entity.

PDU type: BVC-UNBLOCK

Direction: BSS to SGSN

**Table 10.24: BVC-UNBLOCK PDU content**

Information elements	Type / Reference	Presence	Format	Length
PDU type	PDU type/11.3.24	M	V	1
BVCI	BVCI/11.3.6	M	TLV	4

### 10.4.11 BVC-UNBLOCK-ACK

This PDU acknowledges that a BVC has been unblocked.

PDU type: BVC-UNBLOCK-ACK

Direction: SGSN to BSS

**Table 10.25: BVC-UNBLOCK-ACK PDU content**

Information elements	Type / Reference	Presence	Format	Length
PDU type	PDU type/11.3.24	M	V	1
BVCI	BVCI/11.3.6	M	TLV	4

### 10.4.12 BVC-RESET

This PDU indicates that BVC initialisation is required, e.g. because of a BVC failure.

PDU type: BVC-RESET

Direction: SGSN to BSS, BSS to SGSN

**Table 10.26: BVC-RESET PDU content**

Information elements	Type / Reference	Presence	Format	Length
PDU type	PDU type/11.3.24	M	V	1
BVCI	BVCI/11.3.6	M	TLV	4
Cause	Cause/11.3.8	M	TLV	3
Cell Identifier		C	TLV	10

The Cell Identifier IE is mandatory in the BVC-RESET PDU sent from BSS to SGSN in order to reset a BVC corresponding to a PTP functional entity. The Cell Identifier IE shall not be used in any other BVC-RESET PDU.

### 10.4.13 BVC-RESET-ACK

This PDU indicates that BVC initialisation has been executed.

PDU type: BVC-RESET-ACK

Direction: BSS to SGSN, SGSN to BSS

**Table 10.27: BVC-RESET-ACK PDU content**

Information elements	Type / Reference	Presence	Format	Length
PDU type	PDU type/11.3.24	M	V	1
BVCI	BVCI/11.3.6	M	TLV	4
Cell Identifier		C	TLV	10

The Cell Identifier IE is mandatory in the BVC-RESET-ACK PDU sent from BSS to SGSN in response to reset a BVC corresponding to a PTP functional entity. The Cell Identifier IE shall not be used in any other BVC-RESET-ACK PDU.

## 10.4.14 STATUS

This PDU indicates that an exception condition occurred.

PDU type: STATUS

Direction: SGSN to BSS, BSS to SGSN

**Table 10.28: STATUS PDU content**

Information elements	Type / Reference	Presence	Format	Length
PDU type	PDU type/11.3.24	M	V	1
Cause	Cause/11.3.8	M	TLV	3
BVCI	BVCI/11.3.6	C	TLV	4
PDU In Error a)	PDU In Error/11.3.22	O	TLV	3-?

- a) This is the whole PDU (starting with the [PDU type]) within which an error was detected. This PDU may be truncated if it exceeds the information carrying capacity of the underlying network service.

### 10.4.14.1 Static conditions for BVCI

The "BVCI" IE shall be included when the "Cause" IE is set to one of the following values:

- a) "BVCI blocked";

and shall not be included otherwise.

## 10.4.15 SGSN-INVOKE-TRACE

This PDU indicates that the BSS shall begin the production of a trace record for an MS.

PDU type: SGSN-INVOKE-TRACE

Direction: SGSN to BSS

**Table 10.29: SGSN-INVOKE-TRACE PDU content**

Information elements	Type / Reference	Presence	Format	Length
PDU type	PDU type/11.3.24	M	V	1
Trace Type	Trace Type/11.3.36	M	TLV	3
Trace Reference	Trace Reference/11.3.35	M	TLV	4
Trigger Id	Trigger Id/11.3.38	O	TLV	4-24
Mobile Id	Mobile Id/11.3.18	O	TLV	3-10
OMC Id	OMC Id/11.3.21	O	TLV	4-24
TransactionId	TransactionId/11.3.37	O	TLV	4

---

# 11 General information elements coding

The figures and text in this section describe the Information Elements contents.

## 11.1 General structure of the information elements

Refer to General Structure Of The Information Elements/GSM 08.16 [16].

## 11.2 Information element description

Refer to Information Element Description/GSM 08.16 [16].

## 11.3 Information Element Identifier (IEI)

An Information Element Identifier (IEI) is identified by the same coding in all BSSGP PDUs.

**Table 11.1: IEI types**

IEI coding (hexadecimal)	IEI Types
x00	Alignment Octets
x01	Bmax default MS
x02	BSS Area Indication
x03	Bucket Leak Rate
x04	BVCI
x05	BVC Bucket Size
x06	BVC Measurement
x07	Cause
x08	Cell Identifier
x09	Channel needed
x0a	DRX Parameters
x0b	eMLPP-Priority
x0c	Flush Action
x0d	IMSI
x0e	LLC-PDU
x0f	LLC Frames Discarded
x10	Location Area
x11	Mobile Id
x12	MS Bucket Size
x13	MS Radio Access Capability
x14	OMC Id
x15	PDU In Error
x16	PDU Lifetime
x17	Priority
x18	QoS Profile
x19	Radio Cause
x1a	RA-Cap-UPD-Cause
x1b	Routeing Area
x1c	R_default_MS
x1d	Suspend Reference Number
x1e	Tag
x1f	TLLI
x20	TMSI
x21	Trace Reference
x22	Trace Type
x23	TransactionId
x24	Trigger Id
x25	Number of octets affected
RESERVED	All values not explicitly shown are reserved for future use and shall be treated by the recipient as an unknown IEI

### 11.3.1 Alignment octets

The Alignment Octets are used to align a subsequent IEI onto a 32 bit boundary. The element coding is:

**Table 11.2: Alignment octets IE**

	8	7	6	5	4	3	2	1
<b>octet 1</b>	IEI							
<b>octet 2,2a</b>	Length Indicator a)							
<b>octet 3-5</b>	spare octet							

a) The Length Indicator may indicate that from 0 to 3 spare octets are present.

### 11.3.2 Bmax default MS

This information element indicates the default bucket size (Bmax) in octets for an MS. The element coding is:

**Table 11.3: Bmax default MS IE**

	8	7	6	5	4	3	2	1
<b>octet 1</b>	IEI							
<b>octet 2,2a</b>	Length Indicator							
<b>octet 3-4</b>	Bmax							

The Bmax field is coded as in section GSM 08.18 BVC Bucket Size/Bmax.

### 11.3.3 BSS Area Indication

This element is used to indicate that the paging shall be done in all the cells within the BSS. The element coding is:

**Table 11.4: BSS Area Indication IE**

	8	7	6	5	4	3	2	1
<b>octet 1</b>	IEI							
<b>octet 2,2a</b>	Length Indicator							
<b>octet 3</b>	BSS indicator							

The coding of octet 2 is a binary number indicating the Length of the remaining element.

The coding of octet 3 shall not be specified. The recipient shall ignore the value of this octet.

### 11.3.4 Bucket Leak Rate (R)

This information element indicates the leak rate (R) to be applied to a flow control bucket. The element coding is:

**Table 11.5: Bucket Leak Rate IE**

	8	7	6	5	4	3	2	1
<b>octet 1</b>	IEI							
<b>octet 2,2a</b>	Length Indicator							
<b>octet 3</b>	R Value (MSB)							
<b>octet 4</b>	R Value (LSB)							

The R field is the binary encoding of the rate information expressed in 100 bits/sec increments, starting from 0 x 100 bits/sec until 65535 x 100 bits/sec (6 Mbps).

### 11.3.5 BVC Bucket Size

This information element indicates the maximum bucket size (Bmax) in octets for a BVC. The element coding is:

**Table 11.6: BVC Bucket Size IE**

	8	7	6	5	4	3	2	1
<b>octet 1</b>	IEI							
<b>octet 2,2a</b>	Length Indicator							
<b>octet 3</b>	Bmax (MSB)							
<b>octet 4</b>	Bmax (LSB)							

The Bmax field is the binary encoding of the bucket-size information expressed in 100 octet increments, starting from 0 x 100 octets until 65535 x 100 octets (6 Mbytes).

### 11.3.6 BVC I (BSSGP Virtual Connection Identifier)

The BVC I identifies a BVC. The element coding is:

**Table 11.7: BVC I IE**

	8	7	6	5	4	3	2	1
<b>octet 1</b>	IEI							
<b>octet 2,2a</b>	Length Indicator							
<b>octet 3-4</b>	Unstructured value							

### 11.3.7 BVC Measurement

This information element describes average queuing delay for a BVC. The element coding is:

**Table 11.8: BVC Measurement IE**

	8	7	6	5	4	3	2	1
<b>octet 1</b>	IEI							
<b>octet 2,2a</b>	Length Indicator							
<b>octet 3,4</b>	Delay Value (in centi-seconds)							

The Delay Value field is coded as a 16-bit integer value in units of centi-seconds (one hundredth of a second). This coding provides a range of over 10 minutes in increments of 10 msec. As a special case, the hexadecimal value 0xFFFF (decimal 65535) shall be interpreted as “infinite delay”.

### 11.3.8 Cause

The Cause information element indicates the reason for an exception condition. The element coding is:

**Table 11.9: Cause IE**

	8	7	6	5	4	3	2	1
<b>octet 1</b>	IEI							
<b>octet 2,2a</b>	Length Indicator							
<b>octet 3</b>	Cause value							



**Table 11.10: Cause coding**

Cause value (hexadecimal)	semantics of coding
x00	Processor overload
x01	Equipment failure
x02	Transit network service failure
x03	Network service transmission capacity modified from zero kbps to greater than zero kbps
x04	Unknown MS
x05	BVCI unknown
x06	cell traffic congestion
x07	SGSN congestion
x08	O & M intervention
x09	BVCI-blocked
x20	Semantically incorrect PDU
x21	Invalid mandatory information
x22	Missing mandatory IE
x23	Missing conditional IE
x24	Unexpected conditional IE
x25	Conditional IE error
x26	PDU not compatible with the protocol state
x27	Protocol error – unspecified
NOTE: All values not listed shall be treated as “protocol error - unspecified”	

### 11.3.9 Cell Identifier

This information element uniquely identifies one cell. The element coding is:

**Table 11.11: Cell Identifier IE**

	8	7	6	5	4	3	2	1
<b>octet 1</b>	IEI							
<b>octet 2,2a</b>	Length Indicator							
<b>octets 3-8</b>	Octets 3 to 8 contain the value part (starting with octet 2) of the <i>Routing Area Identification IE</i> defined in GSM 04.08 [11], not including GSM 04.08 IEI							
<b>octets 9-10</b>	Octets 9 and 10 contain the value part (starting with octet 2) of the <i>Cell Identity IE</i> defined in GSM 04.08 [11], not including GSM 04.08 IEI							

### 11.3.10 Channel needed

This information element is coded as defined in GSM 09.18. It is relevant to circuit-switched paging requests. The element coding is:

**Table 11.12: Channel needed IE**

	8	7	6	5	4	3	2	1
<b>octet 1</b>	IEI							
<b>octet 2,2a</b>	Length Indicator							
<b>octet 3</b>	Rest of element coded as the value part of the Channel Needed PDU defined in GSM 09.18, not including GSM 09.18 IEI and GSM 09.18 length indicator							

### 11.3.11 DRX Parameters

This information element contains MS specific DRX information. The element coding is:

**Table 11.13: DRX Parameters IE**

	8	7	6	5	4	3	2	1
<b>octet 1</b>	IEI							
<b>octet 2,2a</b>	Length Indicator							
<b>octet 3-n</b>	Rest of element coded as the value part defined in GSM 04.08, not including GSM 04.08 IEI and GSM 04.08 octet length indicator							

### 11.3.12 eMLPP-Priority

This element indicates the eMLPP-Priority of a PDU. The element coding is:

**Table 11.14: eMLPP-Priority IE**

	8	7	6	5	4	3	2	1
<b>octet 1</b>	IEI							
<b>octet 2,2a</b>	Length Indicator							
<b>octet 3</b>	Rest of element coded as the value part of the eMLPP-Priority IE defined in GSM 08.08, not including GSM 08.08 IEI and GSM 08.08 length indicator							

### 11.3.13 Flush Action

The Flush action information element indicates to the SGSN the action taken by the BSS in response to the flush request. The element coding is:

**Table 11.15: Flush Action IE**

	8	7	6	5	4	3	2	1
<b>octet 1</b>	IEI							
<b>octet 2,2a</b>	Length Indicator							
<b>octet 3</b>	Action value							

**Table 11.16: Action coding**

Action value (hexadecimal)	semantics of coding
x00	LLC-PDU(s) deleted
x01	LLC-PDU(s) transferred
All values not explicitly shown are reserved for future use	

### 11.3.14 IMSI

This information element contains the International Mobile Subscriber Identity. The element coding is:

**Table 11.17: IMSI IE**

	8	7	6	5	4	3	2	1
<b>octet 1</b>	IEI							
<b>octet 2,2a</b>	Length Indicator							
<b>octet 3-n</b>	Octets 3-n contain an IMSI coded as the value part (starting with octet 3) of the <i>Mobile Identity IE</i> defined in GSM 04.08, not including GSM 04.08 IEI and GSM 04.08 length indicator							

### 11.3.15 LLC-PDU

This information element contains an LLC-PDU. The element coding is:

**Table 11.18: LLC-PDU IE**

	8	7	6	5	4	3	2	1
octet 1	IEI							
octet 2,2a	Length Indicator							
octet 3	LLC-PDU (first part)							
octet n	LLC-PDU (last part)							

### 11.3.16 LLC Frames Discarded

This element describes the number of LLC frames that have been discarded inside a BSS. The element coding is:

**Table 11.19: LLC Frames Discarded IE**

	8	7	6	5	4	3	2	1
octet 1	IEI							
octet 2,2a	Length Indicator							
octet 3	Number of frames discarded (in hexadecimal)							

### 11.3.17 Location Area

This element uniquely identifies one Location Area. The element coding is:

**Table 11.20: Location Area IE**

	8	7	6	5	4	3	2	1
octet 1	IEI							
octet 2,2a	Length Indicator							
Octets 3-7	Octets 3 to 7 contain the value part (starting with octet 2) of the <i>Location Area Identification IE</i> defined in GSM 04.08 [11], not including GSM 04.08 IEI							

The coding of octet 2 is a binary number indicating the Length of the remaining element.

### 11.3.18 Mobile Id

The element coding is:

**Table 11.21: Mobile Id IE**

	8	7	6	5	4	3	2	1
octet 1	IEI							
octet 2,2a	Length Indicator							
octet 3-n	Octets 3-n contain either the IMSI, IMEISV or IMEI coded as the value part (starting with octet 3) of the <i>Mobile Identity IE</i> defined in GSM 04.08, not including GSM 04.08 IEI and GSM 04.08 length indicator							

### 11.3.19 MS Bucket Size

This information element indicates an MS's bucket size (Bmax). The element coding is:

**Table 11.22: MS Bucket Size IE**

	8	7	6	5	4	3	2	1
<b>octet 1</b>	IEI							
<b>octet 2,2a</b>	Length Indicator							
<b>octet 3-4</b>	Bmax							

The Bmax field is coded as in section GSM 08.18 BVC Bucket Size/Bmax.

### 11.3.20 MS Radio Access Capability

This information element contains the capabilities of the ME. The element coding is:

**Table 11.23: MS Radio Access Capability IE**

	8	7	6	5	4	3	2	1
<b>octet 1</b>	IEI							
<b>octet 2,2a</b>	Length Indicator							
<b>octet 3-n</b>	Rest of element coded as the value part defined in GSM 04.08, not including GSM 04.08 IEI and GSM 04.08 octet length indicator.							

### 11.3.21 OMC Id

The element coding is:

**Table 11.24: OMC Id IE**

	8	7	6	5	4	3	2	1
<b>octet 1</b>	IEI							
<b>octet 2,2a</b>	Length Indicator							
<b>octet 3-22</b>	For the OMC identity, see TS 12.20							

### 11.3.22 PDU In Error

The element coding is:

**Table 11.25: PDU In Error IE**

	8	7	6	5	4	3	2	1
<b>octet 1</b>	IEI							
<b>octet 2,2a</b>	Length Indicator							
<b>octet 3-?</b>	Erroneous BSSGP PDU							

### 11.3.23 PDU Lifetime

This information element describes the PDU Lifetime for a PDU inside the BSS. The element coding is:

**Table 11.26: PDU Lifetime IE**

	8	7	6	5	4	3	2	1
<b>octet 1</b>	IEI							
<b>octet 2,2a</b>	Length Indicator							
<b>octet 3-4</b>	Delay Value							

The Delay Value field is coded as in section GSM 08.18 BVC Measurement/Delay Value.

### 11.3.24 PDU Type

The first octet of a BSSGP PDU shall contain the PDU type IE. The PDU type IE is one octet long.

**Table 11.27: PDU Types**

PDU type coding	PDU Types
(Hexadecimal)	
	PDU types between RL and BSSGP SAPs
x00	- DL-UNITDATA
x01	- UL-UNITDATA
x02	- RA-CAPABILITY
x03	- PTM-UNITDATA
	PDU types between GMM SAPs
x06	- PAGING PS
x07	- PAGING CS
x08	- RA-CAPABILITY-UPDATE
x09	- RA-CAPABILITY-UPDATE-ACK
x0a	- RADIO-STATUS
x0b	- SUSPEND
x0c	- SUSPEND-ACK
x0d	- SUSPEND-NACK
x0e	- RESUME
x0f	- RESUME-ACK
x10	- RESUME-NACK
	PDU types between NM SAPs
x20	- BVC-BLOCK
x21	- BVC-BLOCK-ACK
x22	- BVC-RESET
x23	- BVC-RESET-ACK
x24	- BVC-UNBLOCK
x25	- BVC-UNBLOCK-ACK
x26	- FLOW-CONTROL-BVC
x27	- FLOW-CONTROL-BVC-ACK
x28	- FLOW-CONTROL-MS
x29	- FLOW-CONTROL-MS-ACK
x2a	- FLUSH-LL
x2b	- FLUSH-LL-ACK
x2c	- LLC-DISCARDED
x40	- SGSN-INVOKE-TRACE
x41	- STATUS
RESERVED	all values not explicitly shown are reserved for future use

### 11.3.25 Priority

This element indicates the priority of a PDU. The element coding is:

**Table 11.28: Priority IE**

	8	7	6	5	4	3	2	1
octet 1	IEI							
octet 2,2a	Length Indicator							
octet 3	Rest of element coded as the value part of the Priority IE defined in GSM 08.08, not including GSM 08.08 IEI and GSM 08.08 length indicator							

### 11.3.26 QoS Profile

This information element describes the QoS Profile associated with a PDU. The element coding is:

**Table 11.29: QoS Profile IE**

	8	7	6	5	4	3	2	1
<b>octet 1</b>	IEI							
<b>octet 2,2a</b>	Length Indicator							
<b>octet 3-4</b>	Peak bit rate provided by the network, coded as the value part in Bucket Leak Rate/R IE/ GSM 08.18 a)							
<b>octet 5</b>	SPARE		C/R	T	A	Precedence		

a) The bit rate 0 (zero) shall mean “best effort” in this IE.

“Precedence” is coded as shown below (complying with GSM 03.60).

**Table 11.30: Precedence coding**

coding	semantic	
	DL-UNITDATA	UL-UNITDATA
000	High priority	Radio priority 1
001	Normal priority	Radio priority 2
010	Low priority	Radio priority 3
011	Reserved	Radio priority 4
100	Reserved	Radio Priority Unknown

All values not allocated are reserved. All reserved values shall be interpreted as value 010.

“A-bit” is coded as shown below.

**Table 11.31: “A bit” coding**

coding	semantic
0	Radio interface uses RLC/MAC ARQ functionality
1	Radio interface uses RLC/MAC-UNITDATA functionality

“T-bit” is coded as shown below.

**Table 11.32: “T bit” coding**

coding	semantic
0	The SDU contains signalling (e.g. related to GMM)
1	The SDU contains data

“C/R-bit” is coded as shown below.

**Table 11.47: “C/R bit” coding**

coding	semantic
0	The SDU contains a LLC ACK or SACK command/response frame type
1	The SDU does not contain a LLC ACK or SACK command/response frame type

### 11.3.27 Radio Cause

This information element indicates the reason for an exception condition on the radio interface. The element coding is:

**Table 11.33: Radio Cause IE**

	8	7	6	5	4	3	2	1
<b>octet 1</b>	IEI							
<b>octet 2,2a</b>	Length Indicator							
<b>octet 3</b>	Radio Cause value							

**Table 11.34: Radio Cause value**

radio cause value	semantics of coding
(Hexadecimal)	
x00	Radio contact lost with the MS
x01	Radio link quality insufficient to continue communication
x02	cell-reselection ordered
	All values not explicitly listed are reserved. If received, they shall be handled as "radio contact lost with the MS".

### 11.3.28 RA-Cap-UPD-Cause

The RA-Cap-UPD-Cause indicates the success of the RA-CAPABILITY-UPDATE procedure or the reason of the failure. The element coding is:

**Table 11.35: RA-Cap-UPD-Cause IE**

	8	7	6	5	4	3	2	1
<b>octet 1</b>	IEI							
<b>octet 2,2a</b>	Length Indicator							
<b>octet 3</b>	RA-Cap-UPD Cause value							

**Table 11.36: RA-Cap-UPD Cause value**

RA-Cap-UPD cause value	semantics of coding
(Hexadecimal)	
x00	OK, RA capability IE present
x01	TLLI unknown in SGSN
x02	no RA Capabilities available for this MS
	All values not explicitly listed are reserved. If received, they shall be handled as "TLLI unknown in SGSN".

### 11.3.29 Routeing Area

This element uniquely identifies one routeing area. The element coding is:

**Table 11.37: Routeing Area IE**

	8	7	6	5	4	3	2	1
<b>octet 1</b>	IEI							
<b>octet 2,2a</b>	Length Indicator							
<b>Octets 3-8</b>	Octets 3 to 8 contain the value part (starting with octet 2) of the <i>Routeing Area Identification IE</i> defined in GSM 04.08 [11], not including GSM 04.08 IEI							

The coding of octet 2 is a binary number indicating the Length of the remaining element.

### 11.3.30 R\_default\_MS

This information element indicates the default bucket leak rate (R) to be applied to a flow control bucket for an MS. The element coding is:

**Table 11.38: R\_default\_MS IE**

	8	7	6	5	4	3	2	1
<b>octet 1</b>	IEI							
<b>octet 2,2a</b>	Length Indicator							
<b>octet 3-4</b>	R_default_MS value							

The R\_default\_MS field is coded as in section GSM 08.18 Bucket Leak Rate /R Value.

### 11.3.31 Suspend Reference Number

The Suspend Reference Number information element contains an un-formatted reference number for each suspend/resume transaction. The element coding is:

**Table 11.39: Suspend Reference Number IE**

	8	7	6	5	4	3	2	1
<b>octet 1</b>	IEI							
<b>octet 2,2a</b>	Length Indicator							
<b>octet 3</b>	Suspend Reference Number							

The Suspend Reference Number is an un-formatted 8 bit field.

### 11.3.32 Tag

This information element is used to correlate request and response PDUs. The element coding is:

**Table 11.40: Tag IE**

	8	7	6	5	4	3	2	1
<b>octet 1</b>	IEI							
<b>octet 2,2a</b>	Length Indicator							
<b>octet 3</b>	Unstructured value							

### 11.3.33 Temporary logical link Identity (TLLI)

The element coding is:

**Table 11.41: TLLI IE**

	8	7	6	5	4	3	2	1
<b>octet 1</b>	IEI							
<b>octet 2,2a</b>	Length Indicator							
<b>octet 3-6</b>	Rest of element coded as the value part of the TLLI information element in GSM 04.08, not including GSM 04.08 IEI.							



### 11.3.34 Temporary Mobile Subscriber Identity (TMSI)

The element coding is:

**Table 11.42: TMSI IE**

	8	7	6	5	4	3	2	1
<b>octet 1</b>	IEI							
<b>octet 2,2a</b>	Length Indicator							
<b>octet 3-6</b>	Rest of element coded as the value part of the TMSI/P-TMSI information element in GSM 04.08, not including GSM 04.08 IEI.							

### 11.3.35 Trace Reference

This element provides a trace reference number allocated by the triggering entity. The element coding is:

**Table 11.43: Trace Reference IE**

	8	7	6	5	4	3	2	1
<b>octet 1</b>	IEI							
<b>octet 2,2a</b>	Length Indicator							
<b>octet 3-4</b>	Trace Reference							

### 11.3.36 Trace Type

This element provides the type of trace information to be recorded. The element coding is:

**Table 11.44: Trace Type IE**

	8	7	6	5	4	3	2	1
<b>octet 1</b>	IEI							
<b>octet 2,2a</b>	Length Indicator							
<b>octet 3</b>	This is coded as specified in Technical Specification GSM 12.08.							

### 11.3.37 TransactionId

This element indicates a particular transaction within a trace. The element coding is:

**Table 11.45: Transaction Id IE**

	8	7	6	5	4	3	2	1
<b>octet 1</b>	IEI							
<b>octet 2,2a</b>	Length Indicator							
<b>octet 3-4</b>	Transaction Id							

### 11.3.38 Trigger Id

This element provides the identity of the entity which initiated the trace. The element coding is:

**Table 11.46: Trigger Id IE**

	8	7	6	5	4	3	2	1
<b>octet 1</b>	IEI							
<b>octet 2,2a</b>	Length Indicator							
<b>octet 3-22</b>	Entity Identity ( typically an OMC identity)							

### 11.3.39 Number of octets affected

This information element indicates, for an MS, the number of octets transferred or deleted by BSS. The element coding is:

**Table 11.24: Number of octets affected IE**

	8	7	6	5	4	3	2	1
<b>octet 1</b>	IEI							
<b>octet 2,2a</b>	Length Indicator							
<b>octet 3-5</b>	number of octets transferred or deleted							

The number of octets transferred or deleted by the BSS may be higher than the maximum Bmax value (6553500). SGSN shall handle any value higher than 6553500 as the value 6553500.

## 12 List of system variables

### 12.1 General Variables

**Table 12.1: Procedure timers**

timer mnemonic	value range	notes	relation to other timers
T1	1s<T1<30s	Guards the (un)blocking procedures	none
T2	1s<T2<120s	Guards the reset procedure	none
T3	0.1s<T3<10s	Guards the suspend procedure	none
T4	0.1s<T4<10s	Guards the resume procedure	none
T5	1s<T5<30s	Guards the RA-CAPABILITY-UPDATE procedure	none

**Table 12.2: Procedure retry counters**

retry mnemonic	retry value	notes
BVC-BLOCK-RETRIES	3	none
BVC-UNBLOCK-RETRIES	3	none
BVC-RESET-RETRIES	3	none
SUSPEND-RETRIES	3	none
RESUME-RETRIES	3	none
RA-CAPABILITY-UPDATE-RETRIES	3	none

## 12.2 Flow control variables

**Table 12.3: Flow control variables**

<b>variable mnemonic</b>	<b>value range</b>	<b>notes</b>	<b>relation to other variables</b>
Th	$5s < Th < 6000s$	Interval after Flow-Control-MS before SGSN may use SGSN generated Bmax and R	none
C	$1s < C < 10s$	Minimum interval between sending of subsequent Flow Control PDUs for a given BVC or MS	$C < Th$

## Annex A (informative): Change Request History

Document history		
5.0.0	December 1997	Approved at SMG#24.
6.0.0	March 1998	Included SMG#25 approved change requests A002, A003, A004, A005, A006 and A008.
6.1.0	June 1998	Includes SMG#26 approved change requests: A001r3, A07r5, A009r2, A010, A011r2, A012r3, A018, A019 and A020r2. Sent to PT12 for formatting.
6.2.0	October 1998	Includes SMG#27 approved change requests: A022r1, A23, A024, A025r2, A026, A030r1, and A031.
6.3.0	March 1999	Includes SMG#28 approved change requests: CR A036 A037r1 A038r1 A039 A044 A045 A047r1 A049 A050r1 A051r1 A052 A056r1
6.4.0	July 1999	Includes SMG#29 approved change requests: CR A042r2 Clarification on mapping of BVCI to functional entities CR A058 Encoding of the information elements IMSI, TLLI, TMSI and Mobile Id CR A059 Correction of RA-CAPABILITY-UPDATE-ACK PDU at failed RA-CAPABILITY-UPDATE procedure. CR A060r2 Clarification to Paging Procedure CR A062 Correction of PAGING PS message CR A064 Length of MS Radio Access Capability IE
6.5.0	November 1999	CR A069r1 Corrections to BSSGP CR A071 Downlink data transfer
6.6.0	December 1999	CR A067r2 BSSGP error handling CR A081 FLUSH-LL: Transfer of LLC-PDU(s) to new routing area

CRs agreed at SMG#31:

08.18	A093	1	R97	6.6.0	Length of V part of MS Radio Access Capability	F	6.7.0
08.18	A096		R97	6.4.0	DL-UNITDATA PDU without DRX parameters IE	F	6.5.0

Version 0818-671: Tables have been editorially updated, disturbing page breaks have been removed, and the CR history for SMG#31 have been added.

---

# History

<b>Document history</b>		
V6.1.0	July 1998	Publication
V6.2.0	October 1998	Publication
V6.3.0	March 1999	Publication
V6.4.0	July 1999	Publication
V6.5.0	November 1999	Publication
V6.6.0	December 1999	Publication
V6.7.1	May 2000	Publication