

Digital Video Broadcasting (DVB); DVB mega-frame for Single Frequency Network (SFN) synchronization

European Broadcasting Union



Union Européenne de Radio-Télévision



Reference

RTS/JTC-DVB-164

Keywords

broadcasting, digital, DVB, TV, video

ETSI

650 Route des Lucioles
F-06921 Sophia Antipolis Cedex - FRANCE

Tel.: +33 4 92 94 42 00 Fax: +33 4 93 65 47 16

Siret N° 348 623 562 00017 - NAF 742 C
Association à but non lucratif enregistrée à la
Sous-Préfecture de Grasse (06) N° 7803/88

Important notice

Individual copies of the present document can be downloaded from:

<http://www.etsi.org>

The present document may be made available in more than one electronic version or in print. In any case of existing or perceived difference in contents between such versions, the reference version is the Portable Document Format (PDF). In case of dispute, the reference shall be the printing on ETSI printers of the PDF version kept on a specific network drive within ETSI Secretariat.

Users of the present document should be aware that the document may be subject to revision or change of status. Information on the current status of this and other ETSI documents is available at

<http://portal.etsi.org/tb/status/status.asp>

If you find errors in the present document, send your comment to:

editor@etsi.org

Copyright Notification

No part may be reproduced except as authorized by written permission.
The copyright and the foregoing restriction extend to reproduction in all media.

© European Telecommunications Standards Institute 2004.

© European Broadcasting Union 2004.

All rights reserved.

DECT™, **PLUGTESTS™** and **UMTS™** are Trade Marks of ETSI registered for the benefit of its Members.
TIPHON™ and the **TIPHON logo** are Trade Marks currently being registered by ETSI for the benefit of its Members.
3GPP™ is a Trade Mark of ETSI registered for the benefit of its Members and of the 3GPP Organizational Partners.

Contents

Intellectual Property Rights	4
Foreword.....	4
1 Scope	5
2 References	5
3 Definitions and abbreviations.....	5
3.1 Definitions	5
3.2 Abbreviations	5
4 General description.....	6
5 Mega-frame definition.....	8
6 Mega-frame Initialization Packet (MIP)	9
6.1 Functions	12
6.1.1 Transmitter time offset function	12
6.1.2 Transmitter frequency offset function.....	12
6.1.3 Transmitter power function.....	13
6.1.4 Private data function	13
6.1.5 Cell id function	13
6.1.6 Enable function.....	14
6.1.7 Bandwidth function.....	14
Annex A (normative): CRC decoder model.....	15
Annex B (normative): Functional description of SFN synchronization.....	16
Annex C (normative): Reconfiguration of DVB-T modulator parameters by using the MIP	17
History	18

Intellectual Property Rights

IPRs essential or potentially essential to the present document may have been declared to ETSI. The information pertaining to these essential IPRs, if any, is publicly available for **ETSI members and non-members**, and can be found in ETSI SR 000 314: "*Intellectual Property Rights (IPRs); Essential, or potentially Essential, IPRs notified to ETSI in respect of ETSI standards*", which is available from the ETSI Secretariat. Latest updates are available on the ETSI Web server (<http://webapp.etsi.org/IPR/home.asp>).

Pursuant to the ETSI IPR Policy, no investigation, including IPR searches, has been carried out by ETSI. No guarantee can be given as to the existence of other IPRs not referenced in ETSI SR 000 314 (or the updates on the ETSI Web server) which are, or may be, or may become, essential to the present document.

Foreword

This Technical Specification (TS) has been produced by Joint Technical Committee (JTC) Broadcast of the European Broadcasting Union (EBU), Comité Européen de Normalisation ELECTrotechnique (CENELEC) and the European Telecommunications Standards Institute (ETSI).

NOTE: The EBU/ETSI JTC Broadcast was established in 1990 to co-ordinate the drafting of standards in the specific field of broadcasting and related fields. Since 1995 the JTC Broadcast became a tripartite body by including in the Memorandum of Understanding also CENELEC, which is responsible for the standardization of radio and television receivers. The EBU is a professional association of broadcasting organizations whose work includes the co-ordination of its members' activities in the technical, legal, programme-making and programme-exchange domains. The EBU has active members in about 60 countries in the European broadcasting area; its headquarters is in Geneva.

European Broadcasting Union
CH-1218 GRAND SACONNEX (Geneva)
Switzerland
Tel: +41 22 717 21 11
Fax: +41 22 717 24 81

Founded in September 1993, the DVB Project is a market-led consortium of public and private sector organizations in the television industry. Its aim is to establish the framework for the introduction of MPEG-2 based digital television services. Now comprising over 200 organizations from more than 25 countries around the world, DVB fosters market-led systems, which meet the real needs, and economic circumstances, of the consumer electronics and the broadcast industry.

1 Scope

The present document specifies a mega-frame, including a Mega-frame Initialization Packet (MIP), which may be used for synchronization of Single Frequency Networks (SFN) as well as for the optional control of other important parameters in an SFN.

2 References

The following documents contain provisions which, through reference in this text, constitute provisions of the present document.

- References are either specific (identified by date of publication and/or edition number or version number) or non-specific.
- For a specific reference, subsequent revisions do not apply.
- For a non-specific reference, the latest version applies.

Referenced documents which are not found to be publicly available in the expected location might be found at <http://docbox.etsi.org/Reference>.

- | | |
|-----|---|
| [1] | ISO/IEC 13818-1 (1994): "Information technology - Generic coding of moving pictures and associated audio - Part 1: Systems". |
| [2] | ETSI EN 300 744: "Digital Video Broadcasting (DVB); framing structure, channel coding and modulation for digital terrestrial television". |
| [3] | ETSI EN 300 468: "Digital Video Broadcasting (DVB); Specification for Service Information (SI) in DVB systems". |

3 Definitions and abbreviations

3.1 Definitions

For the purposes of the present document, the following terms and definitions apply:

cell: See EN 300 468 [3], clause 3.1.

DVB-T frame: See EN 300 744 [2], clause 4.4.

DVB-T super-frame: See EN 300 744 [2], clause 4.4.

3.2 Abbreviations

For the purposes of the present document, the following abbreviations apply:

CRC	Cyclic Redundancy Check
DVB	Digital Video Broadcasting
DVB-T	DVB-Terrestrial
ERP	Effective Radiated Power
GPS	Global Positioning System
HP	High Priority
LP	Low Priority
MFN	Multi Frequency Network
MIP	Mega-frame Initialization Packet
MPEG	Moving Pictures Expert Group

MSB	Most Significant Bit
PID	Packet Identifier
pps	pulse per second
RF	Radio Frequency
RS	Reed-Solomon
RX	Receiver
SFN	Single Frequency Network
SI	Service Information
STS	Synchronization Time Stamp
SYNC	SYNChronization
TPH	Transport Packet Header
TPS	Transport Parameter Signalling
TS	Transport Stream
TX	Transmitter

4 General description

Figure 1 shows a block diagram of a complete SFN system.

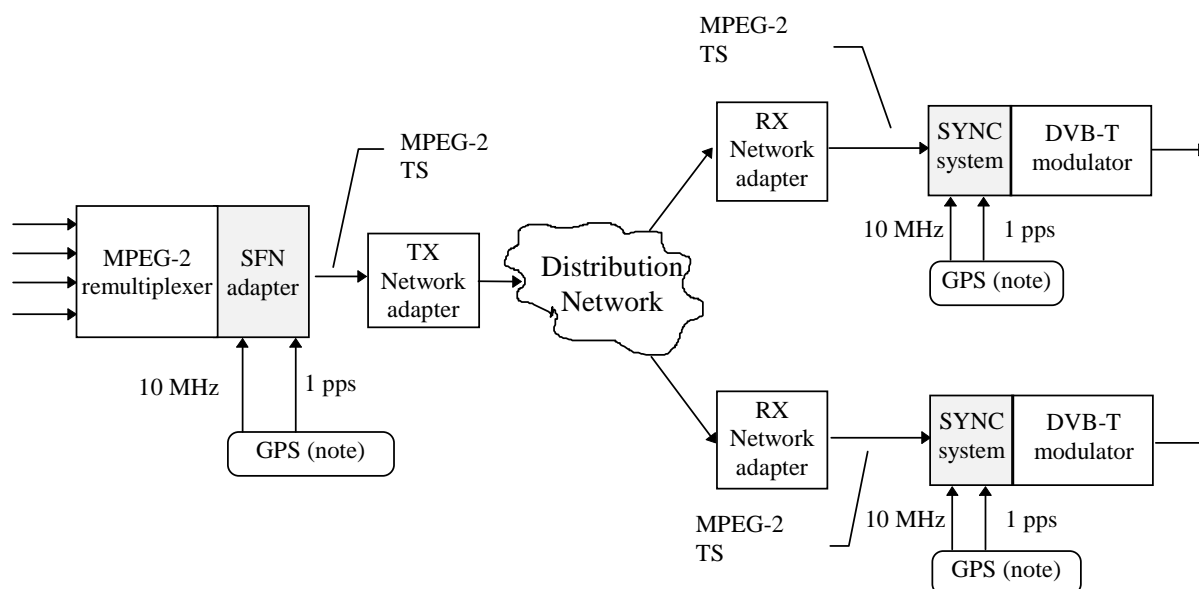

NOTE: Could be any common available frequency reference.

Figure 1: DVB-T primary distribution with SFN adaptation

The SFN functionality is an extension to the DVB system. The blocks associated with SFN functionality are the grey boxes in figure 1. These blocks could be implemented either as separate equipment or integrated in the multiplexer and/or the DVB-T modulator.

SFN system blocks

MPEG-2 re-multiplexer

The MPEG-2 re-multiplexer re-multiplexes the programmes from various input channels, updates the SI and provides an MPEG-2 TS, which, after SFN adaptation, is transmitted via the DVB-T modulators in the SFN.

SFN adapter

The SFN adapter forms a mega-frame, consisting of n TS-packets corresponding to 8 DVB-T frames in the 8K mode or 32 frames in the 2K mode, and inserts a Mega-frame Initialization Packet (MIP) with a dedicated PID value. Inserted anywhere within a mega-frame of index M , the MIP of that mega-frame, MIP_M , allows to uniquely identify the starting point (i.e. the first packet) of the mega-frame $M+1$. This is accomplished by using a pointer carried by the MIP_M itself to indicate its position with regards to the start of the mega-frame $M+1$.

The time difference between the latest pulse of the "one-pulse-per-second" reference, derived e.g. from GPS, that precedes the start of the mega-frame $M+1$ and the actual start (i.e. first bit of first packet) of this mega-frame $M+1$ is copied into the MIP_M . This parameter is called Synchronization Time Stamp (STS).

The time duration of a mega-frame is only dependent on the channel bandwidth and the guard interval proportion, i.e. the mega-frame duration is independent of the duration T_U , constellation and code rate of the DVB-T signal. The mega-frame durations are provided below for all combinations of channel bandwidth and guard interval proportion provided by EN 300 744 [2] (exact values, except where otherwise stated):

Table 1a: Mega-frame duration for all combinations of channel bandwidth and guard interval proportions

Guard Interval	Channel bandwidth			
	8 MHz	7 MHz	6 MHz	5 MHz
$\Delta / T_U = 1/32$	0,5026560 s	0,5744640 s	0,6702080 s	0,8042496 s
$\Delta / T_U = 1/16$	0,5178880 s	0,5918720 s	<i>0,6905173 s</i>	0,8286208 s
$\Delta / T_U = 1/8$	0,5483520 s	0,6266880 s	0,7311360 s	0,8773632 s
$\Delta / T_U = 1/4$	0,6092800 s	0,6963200 s	<i>0,8123733 s</i>	0,9748480 s
NOTE: Approximate values in <i>Italics</i> .				

The output of the SFN adapter shall be fully DVB/MPEG-2 TS compliant.

Transmitter/Receiver network adapter

The network adapters shall provide a transparent link for the MPEG-2 TS from the central to the local units. The maximum network delay - caused by the different paths of the transmission network - the SYNC system can handle is 1 s.

SYNC system

The SYNC system will provide a propagation time compensation by comparing the inserted STS with the local time reference and calculate the extra delay needed for SFN synchronization. See annex B for an example of the synchronization process.

DVB-T modulator

The modulator should provide a fixed delay from the input to the air interface. The information inserted in the MIP could be used for the direct control of the modulator modes or control of other transmitter parameters. The modulator clocks at the different sites have to be synchronized. Since it is a requirement of an SFN that all transmitted signals be identical, the MPEG-2 TS inputs to the various DVB-T modulators have to be bit identical.

Global Positioning System (GPS)

GPS is one among many possible time references but it is the only one available globally. GPS receivers are available which provide both a 10 MHz frequency reference and a 1 pulse per second (1 pps) time reference. The 1 pps time reference, used in SFN synchronization, is divided into 100 ns steps of the 10 MHz clock. The 10 MHz system clock is assumed to be available at all nodes in the network.

The functional blocks "SFN adapter" and "SYNC system" are additional elements for SFN use, and not necessary in MFN applications.

5 Mega-frame definition

The output of the SFN adapter shall be a valid MPEG-2 TS, where the individual packets are organized in groups, which constitute a mega-frame. Each mega-frame consists of n packets, where n is an integer number, which depends on the number of RS-packets per super-frame in the DVB-T mode that will be used for DVB-T emission of the MPEG-2 TS (see EN 300 744 [2], clause 4.7). In the 8K mode n is (the number of RS-packets per super-frame) \times 2. In the 4K mode n is (the number of RS-packets per super-frame) \times 4. In the 2K mode n is (the number of RS-packets per super-frame) \times 8.

Each mega-frame contains exactly one Mega-frame Initialization Packet (MIP). The actual position may vary in an arbitrary way from mega-frame to mega-frame. The pointer value in the MIP is used to indicate the start of the following mega-frame. In figure 2 the overall structure of the mega-frame, including the positioning of the MIP, is given. The exact definition of the MIP format is given in clause 6.

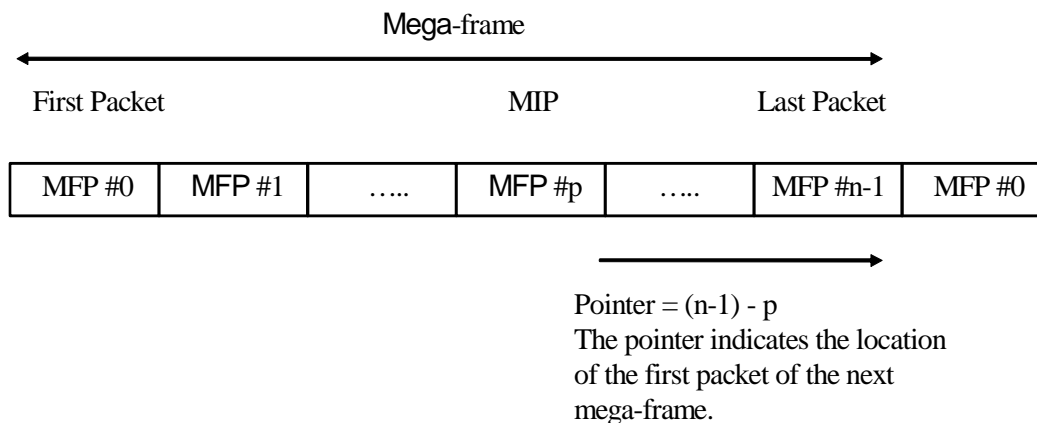

Figure 2: Overall mega-frame structure

The start of a mega-frame in the DVB-T signal is in the present document defined to coincide with the beginning of a DVB-T super-frame and the start of an inverted sync byte, being part of transport multiplex adaptation.

The use of a mega-frame and the insertion of a MIP are additional elements for SFN use, and not necessary in MFN applications.

6 Mega-frame Initialization Packet (MIP)

The MIP is an MPEG-2 compliant Transport Stream (TS) packet, made up of a 4-byte header and a 184-byte data field. The organization of the MIP is shown in table 1b.

Table 1b: Mega-frame Initialization Packet (MIP)

Syntax	Number of bits	Identifier
<code>mega-frame_initialization_packet(){</code>		
<code>transport_packet_header</code>	32	bslbf
<code>synchronization_id</code>	8	uimsbf
<code>section_length</code>	8	uimsbf
<code>pointer</code>	16	uimsbf
<code>periodic_flag</code>	1	bslbf
<code>future_use</code>	15	bslbf
<code>synchronization_time_stamp</code>	24	uimsbf
<code>maximum_delay</code>	24	uimsbf
<code>tps_mip</code>	32	bslbf
<code>individual_addressing_length</code>	8	uimsbf
<i>for (i=0;i<N;i++){</i> <i> tx_identifier</i> <i> function_loop_length</i> <i> for(i=0;i<N;i++){</i> <i> function()</i> <i> }</i> <i>}</i>	16 8	<i>uimsbf</i> <i>uimsbf</i>
<code>crc_32</code>	32	rpchof
<i>for (i=0, i<N,i++){</i> <i> stuffing_byte</i> <i>}</i> <i>}</i>	8	uimsbf
NOTE 1: Optional parameters are shown in italic.		
NOTE 2: All parameter values in the MIPM apply to mega-frame M+1, i.e. to the mega-frame pointed out by the pointer, except for the tps_mip which describes the parameters of mega-frame M+2. See annex C for details.		
NOTE 3: For the definition of the CRC decoder model, see annex A.		
NOTE 4: The length of a MIP shall always be 188 bytes.		

transport_packet_header: The transport_packet_header shall comply with ISO/IEC 13818-1 [1], clause 2.4.3.2, tables 3 and 4.

The PID value for the Mega-frame initialization Packet (MIP) shall be 0×15 .

The payload_unit_start_indicator is not used by the SFN synchronization function and shall be set to 1.

The transport_priority value is not used by the SFN synchronization function and shall be set to 1.

The transport_scrambling_control value shall be set to 00 (not scrambled).

The adaptation_field_control value shall be set to 01 (payload only).

All other parameters are according to ISO/IEC 13818-1 [1], clause 2.4.3.2.

The Transport Packet Header (TPH) is mandatory.

Mandatory SFN parameters

synchronization_id: The synchronization_id is used to identify the synchronization scheme used (see table 2).

Table 2: Signalling format for the synchronization_id

synchronization_id	Function
0x00	SFN synchronization
0x01 to 0xFF	Future use

section_length: The section_length specifies the number of bytes following immediately after the section_length field until, and including, the last byte of the crc_32 but not including any stuffing_byte. The section_length shall not exceed 182 bytes.

pointer: The pointer is a 2-byte binary integer indicating the number of transport packets between the MIP and the first packet of the succeeding mega-frame.

The range of the pointer depends on the DVB-T mode used for emission.

periodic_flag: Indicates if a periodic or an aperiodic insertion of the MIP is performed. Periodic insertion means that the value of the pointer is not time varying. A "0" indicates aperiodic mode and a "1" indicates periodic mode. All SFN "SYNC systems" shall be able to handle both aperiodic and periodic mode.

future_use: Reserved for future use.

synchronization_time_stamp: The synchronization_time_stamp of MIP_M contains the time difference, expressed as a number of 100 ns steps, between the latest pulse of the "one-pulse-per-second" reference (derived e.g. from GPS) that precedes the start of the mega-frame M+1 and the actual start (i.e. beginning of first bit of first packet) of this mega-frame M+1.

maximum_delay: The maximum_delay contains the time difference between the time of emission of the start of mega-frame M+1 of the DVB-T signal from the transmitting antenna and the start of mega-frame M+1 at the SFN adapter, as expressed by the value of its synchronization_time_stamp in the MIP_M . The value of maximum_delay shall be larger than the sum of the longest delay in the primary distribution network and the delays in modulators, power transmitters and antenna feeders. The unit is 100 ns and the range of maximum_delay is 0x000000 to 0x98967F, this equals a maximum delay of 1 s.

tps_mip: The tps_mip consists of 32 bits, P_0 to P_{31} . The relationship between the TPS as defined in EN 300 744 [2] and tps_mip as defined in the present document is described in table 3.

Table 3: Relationship between TPS (as defined in EN 300 744 [2]) and tps_mip (as defined in the present document)

Bit number (TPS)	Format	Purpose/Content	Bit number (tps_mip)
S ₀	see TPS definition in EN 300 744 [2]	Initialization	Not used
S ₁ to S ₁₆	see TPS definition in EN 300 744 [2]	Synchronization word	Not used
S ₁₇ to S ₂₂	see TPS definition in EN 300 744 [2]	Length indicator	Not used
S ₂₃ , S ₂₄	see TPS definition in EN 300 744 [2]	Frame number	Not used
S ₂₅ , S ₂₆	see TPS definition in EN 300 744 [2]	Constellation	P ₀ , P ₁
S ₂₇ , S ₂₈ , S ₂₉	see TPS definition in EN 300 744 [2]	Hierarchy & Interleaving information	P ₂ , P ₃ , P ₄
S ₃₀ , S ₃₁ , S ₃₂	see TPS definition in EN 300 744 [2]	Code rate, HP stream	P ₅ , P ₆ , P ₇
S ₃₃ , S ₃₄ , S ₃₅	see TPS definition in EN 300 744 [2]	Code rate, LP stream	P ₅ , P ₆ , P ₇
S ₃₆ , S ₃₇	see TPS definition in EN 300 744 [2]	Guard interval	P ₈ , P ₉
S ₃₈ , S ₃₉	see TPS definition in EN 300 744 [2]	Transmission mode	P ₁₀ , P ₁₁
S ₄₀ to S ₄₇	see TPS definition in EN 300 744 [2]	Cell identifier	Not used
S ₄₈ to S ₄₉	see TPS definition in EN 300 744 [2]	DVB-H signalling	P ₁₅ , P ₁₆
S ₅₀ to S ₅₃	all set to "0"	Reserved for future use	P ₁₇ to P ₃₁
S ₅₄ to S ₆₇	BCH code	Error protection	Not used
-	see table 4: "Signalling format for the bandwidth"	Bandwidth of the RF channel	P ₁₂ , P ₁₃
-	see table 5: "Signalling format for the bit stream priority"	The priority of the transport stream	P ₁₄

NOTE: There are 15 bits allocated for future use in tps_mip, whereas there are 4 bits allocated in the TPS of EN 300 744 [2].

Table 4: Signalling format for the bandwidth

Bits P ₁₂ , P ₁₃	Bandwidth
00	7 MHz
01	8 MHz
10	6 MHz
11	Other bandwidths than above optionally signalled via bandwidth_function, see clause 6.1.7

Table 5: Signalling format for the bit stream priority

Bit P ₁₄	Transmission mode
0	Low Priority TS
1	Non-hierarchical or High Priority TS

P₀ to P₁₃: In case of inconsistent values of P₀ to P₁₃ for the High Priority and Low Priority Transport Streams, the HP value is valid. In case of change of DVB-T mode, see annex C for the time relationship between P₀-P₁₃ and the TPS data of the DVB-T signal.

individual_addressing_length: The individual_addressing_length field gives the total length of the individual addressing field in bytes. If individual addressing of transmitters is not performed the field value is 0x00, indicating that the crc_32 immediately follows the individual_addressing_length.

crc_32: This 32 bit crc_32 field contains the CRC value that gives a zero output of the registers in the decoder defined in annex A of the present document, after processing all of the bytes in the MIP, excluding the stuffing bytes.

stuffing_byte: Every stuffing_byte has the value 0xFF.

Optional MIP section parameters

tx_identifier: The tx_identifier is a 16 bit word used to address an individual transmitter. The tx_identifier value 0x0000 is used as a broadcast address to address all transmitters in the network.

function_loop_length: The function_loop_length field gives the total length of the function loop field in bytes.

function: The functions are described in clause 6.1.

6.1 Functions

Parameters common to all functions:

function_tag: The function_tag specifies the function identification.

function_length: The function_length field gives the total length of the function field in bytes.

Table 6 gives the function_tag value for the functions defined in the present document. All functions are optional and similar commands could be sent via a separate management network.

Table 6: Tag value of functions

Function	function_tag value
tx_time_offset_function	0x00
tx_frequency_offset_function	0x01
tx_power_function	0x02
private_data_function	0x03
cell_id_function	0x04
enable_function	0x05
bandwidth_function	0x06
Future_use	0x07 to 0xFF

6.1.1 Transmitter time offset function

The tx_time_offset_function is used to apply a deliberate offset in time of the transmitted DVB-T signal, relative to the reference transmission time (STS+maximum_delay) modulo 10^7 .

Table 7: Function transmitter time offset

Syntax	Number of bits	Identifier
tx_time_offset_function(){		
function_tag	8	uimsbf
function_length	8	uimsbf
time_offset	16	tcimsbf
}		

time_offset: The deliberate time offset of the mega-frames. The unit is 100 ns. The range is $[-32\ 768, 32\ 767] \times 100$ ns.

NOTE: The use of the complete range is not foreseen.

6.1.2 Transmitter frequency offset function

The tx_frequency_offset_function is used to apply a deliberate frequency offset of the centre frequency of the emitted DVB-T signal relative to the centre frequency of the RF channel.

Table 8: Function transmitter frequency offset

Syntax	Number of bits	Identifier
tx_frequency_offset_function(){		
function_tag	8	uimsbf
function_length	8	uimsbf
frequency_offset	24	tcimsbf
}		

frequency_offset: The deliberate frequency offset relative to the centre frequency of the RF channel in use. The unit is 1 Hz. The range is $[-8\ 388\ 608, 8\ 388\ 607] \times 1$ Hz.

NOTE: The use of the complete range is not foreseen.

6.1.3 Transmitter power function

The tx_power_function can be used to configure the transmitter ERP.

Table 9: Function transmitter power

Syntax	Number of bits	Identifier
tx_power_function (){		
function_tag	8	uimsbf
function_length	8	uimsbf
tx_power	16	uimsbf
}		

tx_power: The power of the transmitter is defined as the ERP. The unit is 0,1 dB. The range is $([0,65535] \times 0,1)$ dBm.

NOTE: The use of the complete range is not foreseen.

6.1.4 Private data function

The private_data_function is used to send private data to the transmitters via the MIP.

Table 10: Function private data

Syntax	Number of bits	Identifier
private_data_function(){		
function_tag	8	uimsbf
function_length	8	uimsbf
for (i=0;i<N;i++){		
private_data	8	bsb1f
}		
}		

private_data: The private data can be used for proprietary functions.

6.1.5 Cell id function

The cell_id_function can be used to configure the cell identifier of the transmitter.

Table 11: Function cell id

Syntax	Number of bits	Identifier
cell_id_function(){		
function_tag	8	uimsbf
function_length	8	uimsbf
cell_id	16	uimsbf
wait_for_enable_flag	1	bsb1f
reserved_future_use	7	bsb1f
}		

cell_id: The cell_id (EN 300 468 [3]) is used to uniquely identify the cell to which the transmitter belongs to.

wait_for_enable_flag: If this flag is set to "0" then the cell_id within the cell_id_function has to be inserted immediately. If this flag is set to "1" then the cell_id within the cell_id_function has to be inserted immediately after having received the corresponding enable_function.

6.1.6 Enable function

The `enable_function` can be used to execute the change of parameters provided by means of other MIP functions before.

Table 12: Function enable

Syntax	Number of bits	Identifier
<code>enable_function(){</code>		
<code>function_tag</code>	8	uimsbf
<code>function_length</code>	8	uimsbf
<code>for (i=0;i<N;i++){</code>		
<code>enabled_function_tag</code>	8	bsbf
<code>}</code>		
<code>}</code>		

enabled_function_tag: This 8-bit field indicates the function that is enabled by means of the `enable_function`. The coding is according to table 6.

6.1.7 Bandwidth function

The bandwidth function can optionally be used to signal the DVB-T channel bandwidth, when this bandwidth has a value different from 6 MHz, 7 MHz or 8 MHz.

Table 13: Function bandwidth

Syntax	Number of bits	Identifier
<code>bandwidth_function(){</code>		
<code>function_tag</code>	8	uimsbf
<code>function_length</code>	8	uimsbf
<code>ch_bandwidth</code>	7	uimsbf
<code>wait_for_enable_flag</code>	1	bsbf
<code>}</code>		

ch_bandwidth: This 8-bit field indicates the DVB-T channel bandwidth. The coding is according to table 14.

Table 14: Coding of channel bandwidth

bandwidth	Channel bandwidth
0	5 MHz
1 to 127	Reserved for future use

wait_for_enable_flag: If this flag is set to "0" then the bandwidth shall be implemented immediately. If this flag is set to "1" then the bandwidth shall be implemented immediately after having received the corresponding `enable_function`.

Annex A (normative): CRC decoder model

The 32-bit CRC decoder is specified in figure A.1.

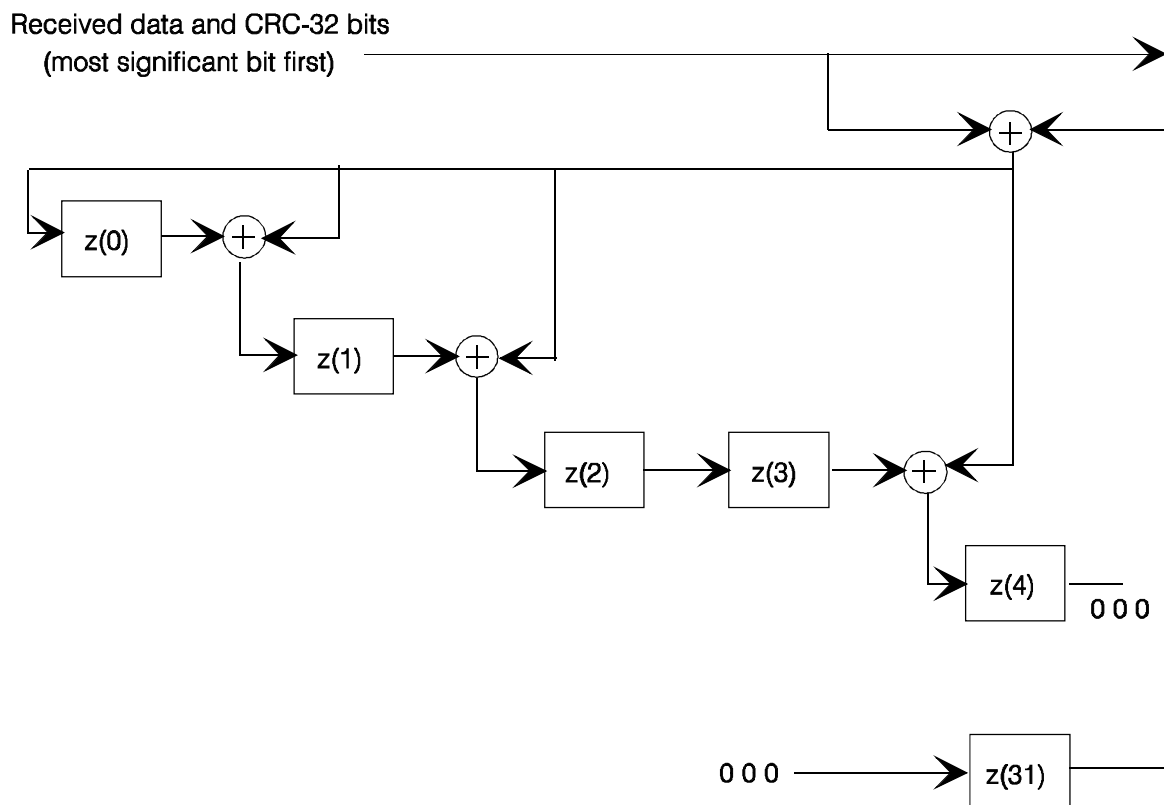

Figure A.1: 32-bit CRC decoder model

The 32 bit CRC decoder operates at bit level and consists of 14 adders + and 32 delay elements $z(i)$. The input of the CRC decoder is added to the output of $z(31)$, and the result is provided to the input $z(0)$ and to one of the inputs of each remaining adder. The other input of each remaining adder is the output of $z(i)$, while the output of each remaining adder is connected to the input of $z(i+1)$, with $i = 0, 1, 3, 4, 6, 7, 9, 10, 11, 15, 21, 22, \text{ and } 25$ (see figure A.1).

This is the CRC calculated with the polynomial:

$$x^{32} + x^{26} + x^{23} + x^{22} + x^{16} + x^{12} + x^{11} + x^{10} + x^8 + x^7 + x^5 + x^4 + x^2 + x + 1$$

Before the CRC processing of the data of a MIP the output of each delay element $z(i)$ is set to its initial value "1". After this initialization, each byte of the MIP is provided to the input of the CRC decoder, including the four `crc_32` bytes, but excluding any stuffing byte. Each byte is shifted into the CRC decoder one bit at a time, with the Most Significant Bit (MSB) first, i.e. from the TS packet sync byte 0x47 (0100 0111) first a "0" enter the CRC decoder, followed by a "1". After shifting the last bit of the last `crc_32` byte into the decoder, i.e. into $z(0)$ after the addition with the output of $z(31)$, the output of all delay elements $z(i)$ is read. In case of no errors, each of the outputs of $z(i)$ has to be zero. At the CRC encoder the `crc_32` field is encoded with such value that this is ensured.

Annex B (normative): Functional description of SFN synchronization

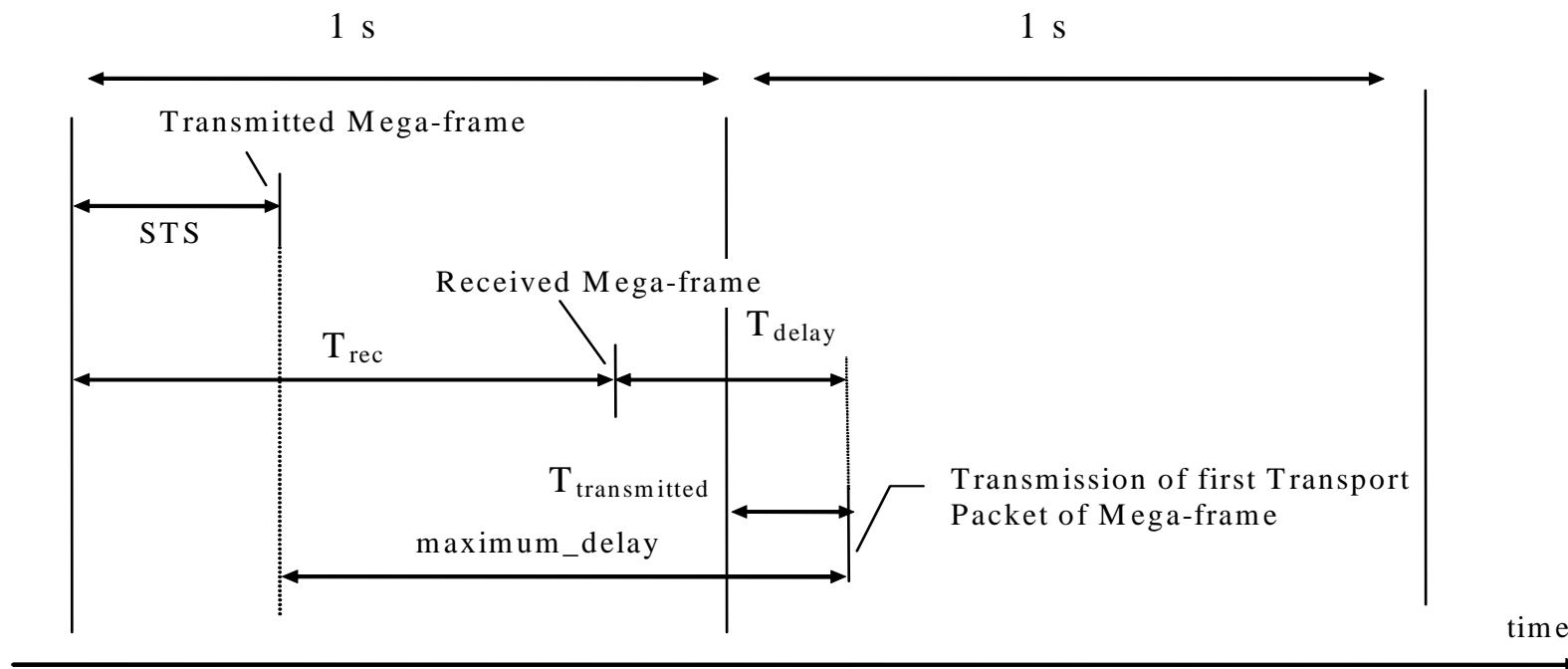

All values are in 100 ns (10 MHz clock)

$$T_{transmitted} = (STS + maximum_delay) \text{ modulo } 10^7 \text{ (from transmitter).}$$

$$T_{delay} = (STS + maximum_delay - T_{rec}) \text{ modulo } 10^7.$$

Figure B.1

Annex C (normative): Reconfiguration of DVB-T modulator parameters by using the MIP

The tps_mip bits P_0 to P_{14} , inserted in the MIP at the multiplexer, are used to reconfigure the parameters of the DVB-T modulator. The bits P_0 to P_{11} are also transmitted as the TPS bits s_{25} to s_{39} of the DVB-T signal, as information to the receiver. In EN 300 744 [2], it is stated that the TPS information transmitted in super-frame m' bits s_{25} to s_{39} always apply to super-frame $m'+1$, whereas all other bits refer to super-frame m' . In order to define a non-ambiguous switch time the following shall apply: Inserted in the MIP being sent in mega-frame 1, the tps_mip describes the parameters of mega-frame 3. The DVB-T modulator will thus be able:

- first to update the data carried by its TPS carriers at the start of the last (i.e. the second in the 8K mode, and the 8th in the 2K mode) super frame of mega-frame 2;
- then to update its new configuration at the start of mega-frame 3.

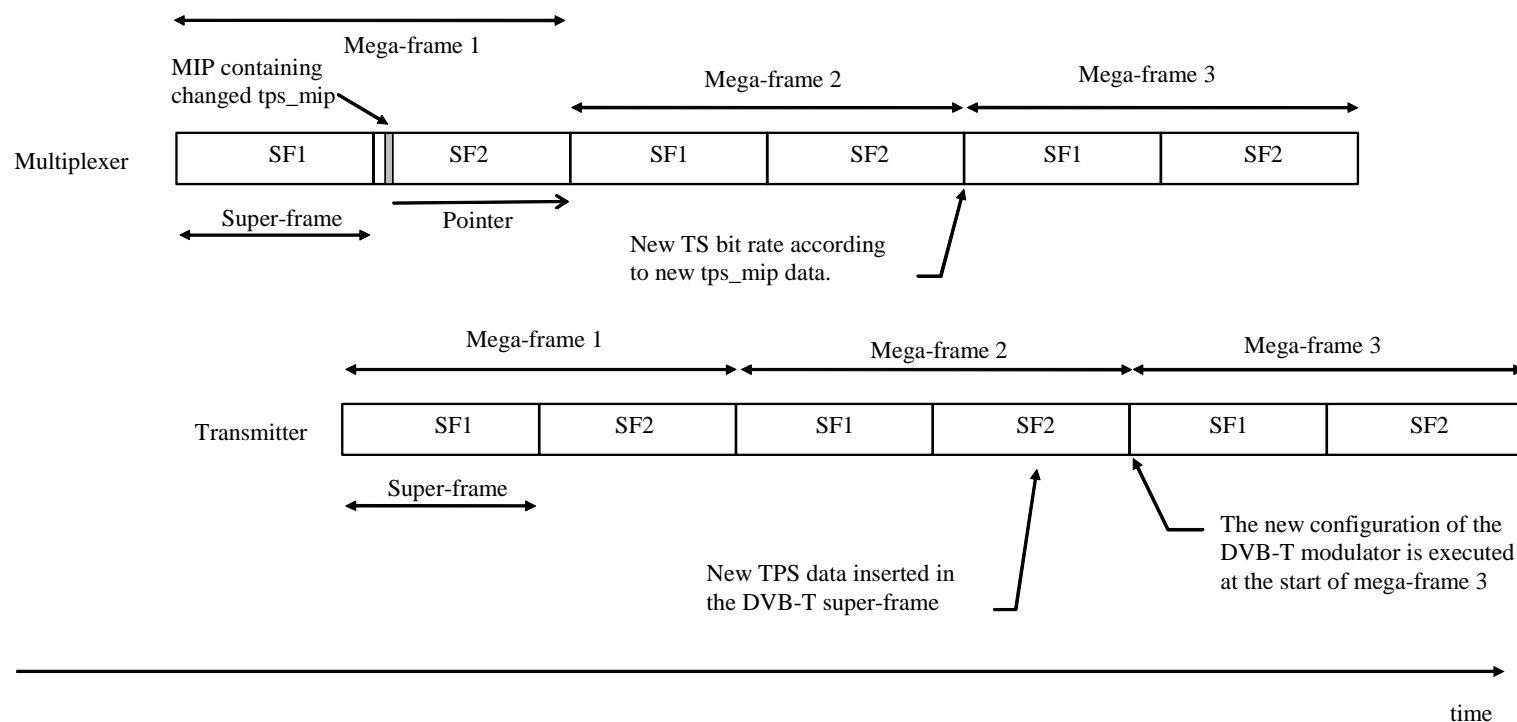

Figure C.1: Reconfiguration of DVB-T modulator parameters by using the MIP

History

Document history		
V1.1.1	April 1997	Publication (Withdrawn)
V1.2.1	April 1998	Publication
V1.3.1	January 2001	Publication
V1.4.1	June 2004	Publication