

ETSI TS 100 930 V7.4.0 (2001-04)

Technical Specification

**Digital cellular telecommunications system (Phase 2+);
Functions related to Mobile Station (MS)
in idle mode and group receive mode
(3GPP TS 03.22 version 7.4.0 Release 1998)**



GLOBAL SYSTEM FOR
MOBILE COMMUNICATIONS



ReferenceRTS/TSGG-020322Q7R3

KeywordsGSM

ETSI

650 Route des Lucioles
F-06921 Sophia Antipolis Cedex - FRANCE

Tel.: +33 4 92 94 42 00 Fax: +33 4 93 65 47 16

Siret N° 348 623 562 00017 - NAF 742 C
Association à but non lucratif enregistrée à la
Sous-Préfecture de Grasse (06) N° 7803/88

Important notice

Individual copies of the present document can be downloaded from:

<http://www.etsi.org>

The present document may be made available in more than one electronic version or in print. In any case of existing or perceived difference in contents between such versions, the reference version is the Portable Document Format (PDF). In case of dispute, the reference shall be the printing on ETSI printers of the PDF version kept on a specific network drive within ETSI Secretariat.

Users of the present document should be aware that the document may be subject to revision or change of status. Information on the current status of this and other ETSI documents is available at <http://www.etsi.org/tb/status/>

If you find errors in the present document, send your comment to:
editor@etsi.fr

Copyright Notification

No part may be reproduced except as authorized by written permission.
The copyright and the foregoing restriction extend to reproduction in all media.

© European Telecommunications Standards Institute 2001.

All rights reserved.

Intellectual Property Rights

IPRs essential or potentially essential to the present document may have been declared to ETSI. The information pertaining to these essential IPRs, if any, is publicly available for **ETSI members and non-members**, and can be found in ETSI SR 000 314: "*Intellectual Property Rights (IPRs); Essential, or potentially Essential, IPRs notified to ETSI in respect of ETSI standards*", which is available from the ETSI Secretariat. Latest updates are available on the ETSI Web server (<http://www.etsi.org/ipr>).

Pursuant to the ETSI IPR Policy, no investigation, including IPR searches, has been carried out by ETSI. No guarantee can be given as to the existence of other IPRs not referenced in ETSI SR 000 314 (or the updates on the ETSI Web server) which are, or may be, or may become, essential to the present document.

Foreword

This Technical Specification (TS) has been produced by the ETSI 3rd Generation Partnership Project (3GPP).

The present document may refer to technical specifications or reports using their 3GPP identities, UMTS identities or GSM identities. These should be interpreted as being references to the corresponding ETSI deliverables.

The cross reference between GSM, UMTS, 3GPP and ETSI identities can be found under www.etsi.org/key.

Contents

| | |
|---|----|
| Foreword | 5 |
| 1 Scope..... | 6 |
| 1.1 References | 6 |
| 1.2 Definitions and abbreviations..... | 8 |
| 2 General description of idle mode..... | 9 |
| 3 Requirements and technical solutions..... | 10 |
| 3.1 PLMN selection and roaming..... | 10 |
| 3.2 Camping on a cell..... | 10 |
| 3.2.1 Normal camping | 10 |
| 3.2.2 "Camp on any cell" | 11 |
| 3.3 Regional provision of service | 11 |
| 3.4 Borders between registration areas..... | 12 |
| 3.5 Barred cells and access control..... | 12 |
| 3.5.1 Barred cells | 12 |
| 3.5.2 Prioritizing cells..... | 12 |
| 3.5.2.1 For cell selection..... | 12 |
| 3.5.2.2 For cell reselection..... | 12 |
| 3.5.3 Access control..... | 12 |
| 3.5.4 Forbidden LA for regional provision of service | 13 |
| 3.6 Radio constraints | 13 |
| 3.7 No suitable cell (limited service state)..... | 14 |
| 3.8 CTS fixed part selection | 14 |
| 4 Overall process structure | 14 |
| 4.1 Process goal..... | 14 |
| 4.2 States description..... | 15 |
| 4.3 List of states..... | 15 |
| 4.3.1 List of states for the PLMN selection process | 15 |
| 4.3.1.1 List of states for automatic mode (figure 2a)..... | 15 |
| 4.3.1.2 List of states for manual mode (figure 2b)..... | 15 |
| 4.3.2 List of States for the cell selection process (figure 3)..... | 15 |
| 4.3.3 List of states for location updating (figure 4) | 16 |
| 4.3.4 List of states for location registration (figure 4) | 16 |
| 4.4 PLMN selection process..... | 17 |
| 4.4.1 Introduction..... | 17 |
| 4.4.2 Registration on a PLMN | 17 |
| 4.4.3 PLMN selection | 18 |
| 4.4.3.1 At switch-on or recovery from lack of coverage | 18 |
| 4.4.3.2 User reselection | 19 |
| 4.4.3.3 In VPLMN of home country..... | 20 |
| 4.4.4 Abnormal cases..... | 20 |
| 4.4.5 Roaming not allowed in this LA | 21 |
| 4.5 Cell selection process | 24 |
| 4.6 Location registration process..... | 27 |
| 4.6.1 General..... | 27 |
| 4.6.2 Initiation of Location Registration..... | 27 |
| 4.6.3 Periodic Location Registration | 29 |
| 4.6.4 IMSI attach/detach operation..... | 29 |
| 4.7 Service indication | 30 |
| 4.8 BCCH allocation broadcasting and storage..... | 31 |
| 4.9 Pageability of the mobile subscriber | 31 |
| 4.10 MM Restart Procedure..... | 32 |
| 5 Group receive mode..... | 32 |
| 5.1 General description..... | 32 |
| 5.2 Requirements and technical solutions | 32 |

5.2.1 Network provisions..... 32
5.2.2 Group receive mode cell monitoring 33
5.2.3 Group receive mode cell change..... 34
5.2.4 Uplink access in group calls 34

Annex A (normative): HPLMN Matching Criteria..... 35

Annex B (informative): Change history 39

Foreword

This Technical Specification has been produced by the 3rd Generation Partnership Project (3GPP).

The contents of the present document are subject to continuing work within the TSG and may change following formal TSG approval. Should the TSG modify the contents of the present document, it will be re-released by the TSG with an identifying change of release date and an increase in version number as follows:

Version x.y.z

where:

- x the first digit:
 - 1 presented to TSG for information;
 - 2 presented to TSG for approval;
 - 3 or greater indicates TSG approved document under change control.
- y the second digit is incremented for all changes of substance, i.e. technical enhancements, corrections, updates, etc.
- z the third digit is incremented when editorial only changes have been incorporated in the document.

1 Scope

The present document gives an overview of the tasks undertaken by a GSM Mobile Station (MS) when in idle mode, that is, switched on but not having a dedicated channel allocated, e.g. not making or receiving a call, or when in group receive mode, that is, receiving a group call or broadcast call but not having a dedicated connection. It also describes the corresponding network functions. The idle mode functions are also performed by a GPRS MS as long as no dedicated channel is allocated to the MS. The idle mode functions are also performed by a CTS MS as long as the CTS MS is in manual mode GSM only or in automatic mode under PLMN coverage.

NOTE: The term GSM MS is used for any type of MS supporting one, or combinations, of the frequency bands specified in GSM 05.05 (e.g. GSM 900, DCS 1800 and PCS 1900).

The present document outlines how the requirements of the GSM 02 series Technical Specifications (especially GSM 02.11) on idle mode operation shall be implemented. Further details are given in GSM 04.08 and GSM 05.08.

Clause 2 of the present document gives a general description of the idle mode process. Clause 3 outlines the main requirements and technical solutions of those requirements. Clause 4 describes the processes used in idle mode. There is inevitably some overlap between these clauses. Clause 5 describes the cell change procedures for a MS in group receive mode.

1.1 References

The following documents contain provisions which, through reference in this text, constitute provisions of the present document.

- References are either specific (identified by date of publication, edition number, version number, etc.) or non-specific.
- For a specific reference, subsequent revisions do not apply.
- For a non-specific reference, the latest version applies. In the case of a reference to a 3GPP document (including a GSM document), a non-specific reference implicitly refers to the latest version of that document *in the same Release as the present document*.

- [1] GSM 01.04: "Digital cellular telecommunications system (Phase 2+); Abbreviations and acronyms".
- [2] GSM 02.01: "Digital cellular telecommunications system (Phase 2+); Principles of telecommunications services supported by a GSM Public Land Mobile Network (PLMN)".
- [3] GSM 02.02: "Digital cellular telecommunication system (Phase 2+); Bearer Services (BS) supported by a GSM Public Land Mobile Network (PLMN)".
- [4] GSM 02.03: "Digital cellular telecommunications system (Phase 2+); Teleservices supported by a GSM Public Land Mobile Network (PLMN)".
- [5] GSM 02.04: "Digital cellular telecommunications system (Phase 2+); General on supplementary services".
- [6] GSM 02.06: "Digital cellular telecommunications system (Phase 2+); Types of Mobile Stations (MS)".
- [7] GSM 02.07: "Digital cellular telecommunications system (Phase 2+); Mobile Station (MS) features".
- [8] GSM 02.09: "Digital cellular telecommunications system (Phase 2+); Security aspects".
- [9] GSM 02.11: "Digital cellular telecommunications system (Phase 2+); Service accessibility".
- [10] GSM 02.16: "Digital cellular telecommunications system (Phase 2+); International Mobile station Equipment Identities (IMEI)".

- [11] GSM 02.17: "Digital cellular telecommunications system (Phase 2+); Subscriber identity modules Functional characteristics".
- [12] GSM 02.24: "Digital cellular telecommunications system (Phase 2+); Description of Charge Advice Information (CAI)".
- [13] GSM 02.30: "Digital cellular telecommunications system (Phase 2+); Man-Machine Interface (MMI) of the Mobile Station (MS)".
- [14] GSM 02.40: "Digital cellular telecommunications system (Phase 2+); Procedures for call progress indications".
- [15] GSM 02.41: "Digital cellular telecommunications system (Phase 2+); Operator determined barring".
- [16] GSM 02.81: "Digital cellular telecommunications system (Phase 2+); Line identification supplementary services - Stage 1".
- [17] GSM 02.82: "Digital cellular telecommunications system (Phase 2+); Call Forwarding (CF) supplementary services - Stage 1".
- [18] GSM 02.83: "Digital cellular telecommunications system (Phase 2+); Call Waiting (CW) and Call Hold (HOLD) supplementary services - Stage 1".
- [19] GSM 02.84: "Digital cellular telecommunications system (Phase 2+); MultiParty (MPTY) supplementary services - Stage 1".
- [20] GSM 02.85: "Digital cellular telecommunications system (Phase 2+); Closed User Group (CUG) supplementary services - Stage 1".
- [21] GSM 02.86: "Digital cellular telecommunications system (Phase 2+); Advice of Charge (AoC) supplementary services - Stage 1".
- [22] GSM 02.88: "Digital cellular telecommunications system (Phase 2+); Call Barring (CB) supplementary services - Stage 1".
- [23] GSM 04.08: "Digital cellular telecommunications system (Phase 2+); Mobile radio interface layer 3 specification".
- [24] GSM 05.02: "Digital cellular telecommunications system (Phase 2+); Multiplexing and multiple access on the radio path".
- [25] GSM 05.08: "Digital cellular telecommunications system (Phase 2+); Radio subsystem link control".
- [26] GSM 02.60: "Digital cellular telecommunications system (Phase 2+); General Packet Radio Service (GPRS); Service description Stage 1".
- [27] GSM 03.60: "Digital cellular telecommunications system (Phase 2+); General Packet Radio Service (GPRS); Service description Stage 2".
- [28] GSM 03.64: "Digital cellular telecommunications system (Phase 2+); General Packet Radio Service (GPRS); Overall description of the GPRS Radio Interface; Stage 2".
- [29] GSM 02.56: "Digital cellular telecommunications system (Phase 2+); GSM Cordless Telephony System (CTS); Service Description; Stage 1
- [30] GSM 03.56: "Digital cellular telecommunications system (Phase 2+); GSM Cordless Telephony System (CTS); CTS Architecture Description; Stage 2

1.2 Definitions and abbreviations

Abbreviations used in the present document are listed in GSM 01.04.

| | |
|-------------------------------------|--|
| Home PLMN | This is a PLMN where the MCC and MNC of the PLMN identity match the MCC and MNC of the IMSI. Matching criteria are defined in Annex A. |
| Selected PLMN | This is the PLMN that has been selected according to subclause 3.1, either manually or automatically. |
| Available PLMN | This is a PLMN where the MS has found a cell that satisfies conditions (ii) and (iv) of subclause 3.2.1. |
| Registered PLMN (RPLMN) | This is the PLMN on which certain LR outcomes have occurred (see table 1). |
| Allowable PLMN | In the case of a MS operating in MS operation mode A or B, this is a PLMN which is not in the list of forbidden PLMNs in the MS. In the case of a MS operating in MS operation mode C, this is a PLMN which is not in the list of forbidden PLMNs or in the list of "forbidden PLMNs for GPRS service" in the MS. |
| Visited PLMN of home country | This is a PLMN, different from the home PLMN, where the MCC part of the PLMN identity is the same as the MCC of the IMSI. |
| Registration | This is the process of camping on a cell of the PLMN and doing any necessary LRs. |
| Camped on a cell | The MS (ME if there is no SIM) has completed the cell selection/reselection process and has chosen a cell from which it plans to receive all available services. Note that the services may be limited, and that the PLMN may not be aware of the existence of the MS (ME) within the chosen cell. |
| Current serving cell | This is the cell on which the MS is camped. |
| Suitable Cell | This is a cell on which an MS may camp. It must satisfy criteria (i) to (v) of subclause 3.2.1. For an MS in group receive mode, the suitable cell is determined by the criteria defined in subclause 5.2.3. |
| Acceptable Cell | This is a cell that the MS may camp on to make emergency calls. It must satisfy criteria (ii) and (iv) of subclause 3.2.1. |
| Group call | A communication in which several MSs can receive, but at most one may be allowed to transmit on a radio channel. Examples of group calls are those established for the voice group call service (VGCS, see GSM 03.68). |
| Broadcast call | A communication in which several MSs can receive, but only the originator of the call is allowed to transmit on the radio channel. Examples of the broadcast call are those established for the voice broadcast service (VBS, see GSM 03.69). |
| Group receive mode | State of the MS when it is engaged in a group or broadcast call as a listener. |
| GPRS MS | An MS capable of GPRS services is a GPRS MS. |
| MS operation mode | See GSM 03.60[27]. |
| CTS MS | An MS capable of CTS services is a CTS MS. |
| Location Registration (LR) | An MS which is IMSI attached to non-GPRS services only performs location registration by the Location Updating procedure. A GPRS MS which is IMSI attached to GPRS services or to GPRS and non-GPRS services performs location registration by the Routing Area Update procedure only when in a network of network operation mode I. Both procedures are performed independently by the GPRS MS when it is IMSI attached to GPRS and non-GPRS services in a network of network operation mode II or III (see GSM 03.60). |
| Localised Service Area (LSA) | A localised service area consists of a cell or a number of cells. The cells constituting a LSA may not necessarily provide contiguous coverage. |
| SoLSA exclusive access | Cells on which normal camping is allowed only for MS with Localised Service Area (LSA) subscription. |

Registration Area A registration area is an area in which mobile stations may roam without a need to perform location registration. The registration area corresponds to location area (LA) for performing location updating procedure and it corresponds to routing area for performing the routing area update procedure.

The PLMN to which a cell belongs (PLMN identity) is given in the system information transmitted on the BCCH (MCC + MNC part of LAI).

2 General description of idle mode

When an MS is switched on, it attempts to make contact with a GSM public land mobile network (PLMN). The particular PLMN to be contacted may be selected either automatically or manually. The MS looks for a suitable cell of the chosen PLMN and chooses that cell to provide available services, and tunes to its control channel. This choosing is known as "camping on the cell". The MS will then register its presence in the registration area of the chosen cell if necessary, by means of a location registration (LR), GPRS attach or IMSI attach procedure. If the MS loses coverage of a cell, it reselects onto the most suitable alternative cell of the selected PLMN and camps on that cell. If the new cell is in a different registration area, an LR request is performed. If the MS loses coverage of a PLMN, either a new PLMN is selected automatically, or an indication of which PLMNs are available is given to the user, so that a manual selection can be made.

Registration is not performed by MSs only capable of services which need no registration for example GPRS services PTM-M or PTP anonymous access.

The purpose of camping on a cell in idle mode is threefold:

- a) It enables the MS to receive system information from the PLMN.
- b) If the MS wishes to initiate a call, it can do this by initially accessing the network on the control channel of the cell on which it is camped (with the exceptions defined in subclauses 3.5.3 and 3.5.4).
- c) If the PLMN receives a call for the MS, it knows (in most cases) the registration area of the cell in which the MS is camped. It can then send a "paging" message for the MS on control channels of all the cells in the registration area. The MS will then receive the paging message because it is tuned to the control channel of a cell in that registration area, and the MS can respond on that control channel.

If the MS is unable to find a suitable cell to camp on, or the SIM is not inserted, or if it receives certain responses to an LR request (e.g., "illegal MS"), it attempts to camp on a cell irrespective of the PLMN identity, and enters a "limited service" state in which it can only attempt to make emergency calls.

If the CTS MS is in CTS mode only or in automatic mode with CTS preferred, it will start by attempting to find a CTS fixed part on which it is enrolled

The idle mode tasks can be subdivided into 4 processes:

- PLMN selection;
- Cell selection and reselection;
- Location registration;
- CTS fixed part selection.

To make this initial CTS fixed part selection, the MS shall be enrolled on at least one fixed part.

The relationship between these processes is illustrated in figure 1. The states and state transitions within each process are shown in figures 2 to 4.

3 Requirements and technical solutions

The following subclauses list the main requirements of idle mode operation and give an outline of the technical solution.

3.1 PLMN selection and roaming

The MS normally operates on its home PLMN (HPLMN). However a visited PLMN (VPLMN) may be selected, e.g., if the MS loses coverage. There are two modes for PLMN selection:

- i) Automatic mode - This mode utilizes a list of PLMNs in priority order. The highest priority PLMN which is available and allowable is selected.
- ii) Manual mode - Here the MS indicates to the user which PLMNs are available. Only when the user makes a manual selection does the MS try to obtain normal service on the VPLMN.

There are two cases:

- International Roaming - This is where the MS receives service on a PLMN of a different country than that of the HPLMN.
- National Roaming - This is where the MS receives service from a PLMN of the same country as that of the HPLMN, either anywhere or on a regional basis. The MS makes a periodic search for the HPLMN while national roaming.

To prevent repeated attempts to have roaming service on a not allowed LA, when the MS is informed that an LA is forbidden, the LA is added to a list of "forbidden LAs for roaming" which is stored in the MS. This list is deleted when the MS is switched off or when the SIM is removed. Such area restrictions are always valid for complete location areas independent of possible subdivision into GPRS routing areas. The structure of the routing area identifier (GSM 03.03) supports area restriction on LA basis.

If a "PLMN not allowed" message is received by an MS in response to an LR request from a VPLMN, that VPLMN is added to a list of "forbidden PLMNs" in the SIM and thereafter that VPLMN will not be accessed by the MS when in automatic mode. A PLMN is removed from the "forbidden" list if, after a subsequent manual selection of that PLMN, there is a successful LR. This list is retained when the MS is switched off or the SIM is removed. The HPLMN shall not be stored on the list of "forbidden PLMNs".

A ME not supporting SoLSA may consider a cell with the escape PLMN code (see GSM 03.73) to be a part of a PLMN belonging to the list of "forbidden PLMNs".

Optionally the ME may store in its memory an extension of the forbidden PLMN list. The contents of the extension of the list shall be deleted when the MS is switched off or the SIM is removed.

If a "GPRS services not allowed in this PLMN" message is received by an MS in response to an GPRS attach, GPRS detach or routing area update request from a VPLMN, that VPLMN is added to a list of "forbidden PLMNs for GPRS service" which is stored in the MS and thereafter that VPLMN will not be accessed by the MS for GPRS service when in automatic mode. This list is deleted when the MS is switched off or when the SIM is removed. A PLMN is removed from the list of "forbidden PLMNs for GPRS service" if, after a subsequent manual selection of that PLMN, there is a successful GPRS attach. The maximum number of possible entries in this list is implementation dependant, but must be at least one entry. The HPLMN shall not be stored on the list of "forbidden PLMNs for GPRS service".

3.2 Camping on a cell

3.2.1 Normal camping

For normal service, the MS has to camp on a suitable cell, tune to that cell's control channel(s), and possibly register within the PLMN so that the MS can:

- a) Receive system information from the PLMN, e.g., the cell options on the BCCH;
- b) Receive paging messages from the PLMN, e.g., when there is an incoming call for the MS;

- c) Initiate call setup for outgoing calls or other actions from the MS (where possible, see subclauses 3.5.3 and 3.5.4).

The choice of such a suitable cell for the purpose of receiving normal service is referred to as "normal camping". There are various requirements that a cell must satisfy before an MS can perform normal camping on it:

- i) It should be a cell of the selected PLMN;
- ii) It should not be "barred" (see subclause 3.5.1);
- iii) It should not be in an LA which is in the list of "forbidden LAs for roaming";
- iv) The radio path loss between MS and BTS must be below a threshold set by the PLMN operator. This is estimated as shown in subclause 3.6;
- v) It should not be a SoLSA exclusive cell to which MS does not subscribe. This requirement is only valid for MSs supporting SoLSA.

Initially, the MS looks for a cell which satisfies these 5 constraints ("suitable cell") by checking cells in descending order of received signal strength. If a suitable cell is found, the MS camps on it and performs any registration necessary. Cells can have two levels of priority, suitable cells which are of low priority are only camped on if there are no other suitable cells of normal priority. (This is called "cell selection").

When camped on a cell the MS regularly looks to see if there is a better cell in terms of a cell re-selection criterion, and if there is, the better cell is selected. Also if one of the other criteria changes, (e.g., the current serving cell becomes barred), or there is a downlink signalling failure (see subclause 3.6), a new cell is selected. (This is called "cell reselection").

In order to speed up these processes, a list of the RF channels containing BCCH carriers of the same PLMN is broadcast on the BCCH, see subclause 4.8. Also, the MS does not need to search all possible RF channels to find a suitable cell. If, after searching the number of RF channels, given for each frequency band below, with the strongest received signal level, a BCCH carrier has been found but no suitable cell of the selected PLMN has been found, the MS can stop the attempt to find a suitable cell of the selected PLMN.

The number of channels to be searched are 30 for GSM 900 and 40 for DCS 1800 and PCS 1900.

3.2.2 "Camp on any cell"

If the MS cannot find a suitable cell, it attempts to camp on any acceptable cell and enter a "limited service state", as defined in subclause 3.7.

3.3 Regional provision of service

An MS may have a "regionally restricted service" where it can only obtain service on certain LAs. If such an MS attempts to camp on a cell of an LA for which it does not have service entitlement, when it does an LR request, it will receive an "LA not allowed" message. In this case:

- The MS stores the forbidden LA identity (LAI) in a list of "forbidden LAIs for regional provision of service", to prevent repeated access attempts on a cell of the forbidden LA. This list is deleted when the MS is switched off or the SIM is removed. If the MS cannot find a suitable cell, the MS performs the PLMN selection procedure starting at subclause 4.4.3.1 A or B.

The MS may also have Localised Service Area cells which are preferred for camping. The MS shall then use the SoLSA cell selection algorithms (see GSM 05.08).

A cell may be reserved for SoLSA exclusive access (see GSM 04.08 and 04.60). An MS is only allowed to camp normally on such a cell if it has a Localised Service Area subscription to the cell. Other MS may camp for limited service.

- NOTE: In a SoLSA exclusive cell the MCC+MNC code is replaced by a unique escape PLMN code (see GSM 03.73), not assigned to any PLMN, in SI3 and SI4. An MS not supporting SoLSA may request for location update to an exclusive access cell. In this case the location attempt is rejected with the cause "PLMN not allowed" and the escape PLMN code is added to the list of the "forbidden PLMNs".

3.4 Borders between registration areas

If the MS is moving in a border area between registration areas, it might repeatedly change between cells of different registration areas. Each change of registration area would require an LR, which would cause a heavy signalling load and increase the risk of a paging message being lost. To prevent this, a "CELL_RESELECT_HYSTERESIS" (CRH) parameter is used. A cell in a different registration area is only selected if it is "better", in terms of the path loss criterion (see subclause 3.6), than all the cells in the current registration area by at least the value of CRH. The CRH parameter is broadcast as system information. As the value of CRH broadcast may be different on different cells, the CRH parameter to be used is that broadcast on the current serving cell. There is also a lower limit on the time interval between reselection of cells on different registration areas. Instead of CRH a GPRS MS uses a "GPRS_CELL_RESELECT_HYSTERESIS" if provided.

3.5 Barred cells and access control

3.5.1 Barred cells

The PLMN operator may decide not to allow MSs to camp on certain cells. (These cells may, for example, only be used for hand over traffic, i.e. calls which need to be handed over to other cells). Barred cell information is broadcast as system information to instruct MSs not to camp on these cells. The barred cell status may in fact change dynamically; hence the MS needs to regularly check the system information for this parameter.

The barred status of a cell depends both on CELL_BAR_ACCESS and on the cell's priority indicated by CELL_BAR_QUALIFY. The effect of these two parameters is further described in GSM 05.08.

If a cell is barred this applies both for cell selection and reselection.

3.5.2 Prioritizing cells

In general, cell prioritization is a means of encouraging MSs to select some suitable cells in preference to others. Since the priority comparison is only between suitable cells, prioritization does not affect coverage. Operators may prefer a certain type of cell not to be selected unless it is the only suitable type. For example, umbrella cells due to their large frequency reuse distance, or microcells because the MS could be travelling too fast for them.

3.5.2.1 For cell selection

During cell selection (see subclause 3.2.1), a cell with low priority indication will only be selected if a suitable cell of normal priority cannot be found.

3.5.2.2 For cell reselection

Cell prioritization can also be achieved during cell reselection by the use of the reselection parameters optionally broadcast. Cells are reselected on the basis of a parameter called C2 and the C2 value for each cell is given a positive or negative offset to encourage or discourage MSs to reselect that cell. A full range of positive and negative offsets is provided to allow the incorporation of this feature into already operational networks. Instead of C2 a GPRS MS uses the GPRS cell reselection parameter if provided.

An MS supporting SoLSA with SoLSA subscription shall use the SoLSA cell re-selection parameters.

3.5.3 Access control

Due to problems in certain areas, Network Operators may decide to restrict access from some MSs (e.g., in case of congestion on the AGCH), and for this reason the access control mechanism is provided.

At subscription one or more access control classes are allocated to the subscriber and stored in the SIM. The information providing all authorized classes is broadcast as system information (together with a bit indicating whether emergency calls may be made). This information is modified dynamically and therefore the MS has to check the system information before each attempt to access.

The MS ignores the Access Control information when selecting a cell to camp on, i.e. it shall not reject a cell for camping on because access on that cell is not allowed.

3.5.4 Forbidden LA for regional provision of service

When the MS is camped on a cell, the LA of which belongs to the list of forbidden LA for regional provision of service, the MS is not allowed to initiate establishment of a CM connection except for an emergency call; it may respond to paging. Also, the MS is not allowed to request GPRS services when camped on a cell of a LA of which belongs to the list of forbidden LA.

If the MS has received the cause "LA not allowed", it shall ignore this fact when selecting a cell to camp on, i.e. it shall not reject a cell for camping on because that cell is part of a LA where this cause has been received.

3.6 Radio constraints

The MS uses a "path loss criterion" parameter C1 to determine whether a cell is suitable to camp on. C1 depends on 4 parameters:

- i) The received signal level (suitably averaged);
- ii) The parameter RXLEV_ACCESS_MIN, which is broadcast as system information, and is related to the minimum signal that the operator wants the network to receive when being initially accessed by an MS;
- iii) The parameter MS_TXPWR_MAX_CCH, which is also broadcast as system information, and is the maximum power that an MS may use when initially accessing the network;
- iv) The maximum power of the MS.

The formula for determining C1 is given in GSM 05.08.

Use of the parameter C1 enables the MS to determine whether communication is possible with the network in the absence of interference. However because of the possibility of interference degrading the communications, an additional safeguard is used. This is to monitor the success rate of the MS in decoding signalling blocks of the paging subchannel. If there is a downlink signalling failure, i.e. the success rate drops too low, this indicates probable interference on the downlink, and the MS attempts to find another suitable cell. Downlink signalling failure monitoring is specified in GSM 05.08.

In order to optimize cell reselection, additional cell reselection parameters can be broadcast as system information of each cell. The cell reselection process employs a parameter C2 which depends on these parameters.

The parameters used to calculate C2 are as follows:

- i) CELL_RESELECT_OFFSET (see subclause 3.5.2.2);
- ii) PENALTY_TIME;

When the MS places the cell on the list of the strongest carriers as specified in GSM 05.08, it starts a timer which expires after the PENALTY_TIME. This timer will be reset when the cell is taken off the list. For the duration of this timer, C2 is given a negative offset. This will tend to prevent fast moving MSs from selecting the cell.

- iii) TEMPORARY_OFFSET;

This is the amount of the negative offset described in (ii) above. An infinite value can be applied, but a number of finite values are also possible.

The permitted values of these parameters and the way in which they are combined to calculate C2 are defined in GSM 05.08.

Instead of the parameter C2, a GPRS MS applies the corresponding GPRS parameter if provided.

An MS supporting SoLSA with SoLSA subscription shall use the SoLSA cell re-selection parameters.

3.7 No suitable cell (limited service state)

There are a number of situations in which the MS is unable to obtain normal service from a PLMN. These include:

- a) Failure to find a suitable cell of the selected PLMN;
- b) No SIM in the MS;
- c) A "PLMN not allowed" response to an LR;
- d) An "illegal MS", "illegal ME" or "IMSI unknown in HLR" response to an LR (any SIM in the ME is then considered "invalid");
- e) A "GPRS not allowed" response to an LR of a GPRS MS operating in MS operation mode C (the cell selection state of GPRS MSs attached to GPRS and non-GPRS depends on the outcome of the location updating);
- f) A "GPRS services not allowed in this PLMN" response to an LR of a GPRS MS operating in MS operation mode C.

(In automatic PLMN selection mode, events (a), (c) and (e) would normally cause a new PLMN selection, but even here, the situation may arise when no PLMNs are available and allowable for use).

Under any of these conditions, the MS attempts to camp on an acceptable cell, irrespective of its PLMN identity, so that emergency calls can be made if necessary. When in the limited service state with a valid SIM, the MS shall search for available and allowable PLMNs in the manner described in subclause 4.4.3.1. To minimize the time taken to find new available PLMNs while maintaining battery life, discontinuous search schemes may be used, see GSM 02.11. No LR requests are made until a valid SIM is present and either a suitable cell is found or a manual network reselection is performed. In the limited service state the presence of the MS need not be known to the PLMN on whose cell it has camped. Cell reselection takes place as normal, except that a zero dB value of CRH will be used.

There are also other conditions under which only emergency calls may be made. These are shown in table 2.

3.8 CTS fixed part selection

In CTS mode only or in automatic mode with CTS preferred, the CTS MS normally operates on a CTS fixed part on which the mobile station is already enrolled. If the CTS MS loses CTS coverage in these modes, it shall attempt periodically to select again a CTS fixed part.

To select a CTS fixed part, the CTS MS shall listen to the CTSBCH frequencies of all the fixed parts on which the MS is currently enrolled.

If the CTS MS is moving in a border area between one area with CTS coverage and one without it, it might repeatedly require CTS attachments and LU on the PLMN. To prevent this, the criteria C1_CTS and C2_CTS (defined in GSM 05.08 subclause 11.1) are used. To attach to a CTS FP, the C1_CTS criterion shall be greater than zero. When the C2_CTS criterion falls below zero, the CTS MS shall consider itself to be no more under CTS coverage.

4 Overall process structure

4.1 Process goal

The aim of the idle mode processes is to achieve the following conditions ("normal service state"):

- a) The registered PLMN is the selected PLMN;
- b) The MS is camped on a suitable cell of the registration area on which the last successful LR was performed, and that cell has the highest value of C2 for any unbarred cell in that registration area;
- c) The value of C2 for the MS is not lower than the value of C2 for any suitable cell in another registration area of the selected PLMN by more than the hysteresis value CRH.

Instead of the parameter C2, a GPRS MS applies the corresponding GPRS parameter if provided.

An MS supporting SoLSA with SoLSA subscription shall use the SoLSA cell re-selection parameters.

Registration is not performed by MSs only capable of services which need no registration for example GPRS services PTM-M or PTP anonymous access.

There may be temporary conditions under which not all these are fully satisfied, e.g., during cell selection on a PLMN or while in the process of reselecting another cell. However, if the above cannot be satisfied for a certain period of time, the MS will normally enter a "limited service state" in which it will try to camp on an acceptable cell. In this state, only emergency calls are possible.

4.2 States description

Each of the processes of PLMN selection, cell selection and location registration can be described by a set of states. The overall state of the mobile is thus a composite of the states of the three processes. In some cases, an event which causes a change of state in one process may trigger a change of state in another process, e.g., camping on a cell in a new registration area triggers an LR request. The relationship between the processes is illustrated in figure 1.

The states in which the MS may be, for each of the processes, are described below and illustrated in figures 2 to 4. For many of the states, a fuller description can be found in other GSM Technical Specifications, and a reference to the GSM Technical Specification and the relevant section within it, are given after the state description.

In the event of any conflict between the diagrams and the text in the present document, the text takes precedence.

4.3 List of states

4.3.1 List of states for the PLMN selection process

4.3.1.1 List of states for automatic mode (figure 2a)

- A1 Trying RPLMN - The MS is trying to perform a Location Registration on the registered PLMN.
- A2 On PLMN - The MS has successfully registered on a PLMN.
- A3 Trying PLMN - The MS is trying to register on a PLMN in the ordered list of PLMNs.
- A4 Wait for PLMNs to appear - There are no allowable and available PLMNs at present and the MS is waiting for one to appear.
- A5 HPLMN search in progress - The MS is trying to find if the HPLMN is available.
- A6 No SIM - There is no SIM in the MS, or certain LR responses have been received.

4.3.1.2 List of states for manual mode (figure 2b)

- M1 Trying registered PLMN - The MS is trying to perform a Location Registration on the registered PLMN.
- M2 On PLMN - The MS has successfully registered on a PLMN.
- M3 Not on PLMN - The MS has failed to register on the selected PLMN.
- M4 Trying PLMN - The MS is trying to register on a user selected PLMN.
- M5 No SIM - There is no SIM in the MS, or certain LR responses have been received.

4.3.2 List of States for the cell selection process (figure 3)

- C1 Normal Cell Selection - This is the process of initial cell selection, searching all RF channels.
- C2 Stored List Cell Selection - This is the process of initial cell selection where BCCH carrier information (e.g. a BA list) for the selected PLMN is stored in the MS.

- C3 Camped Normally - This is where the MS is camped on a cell of the selected PLMN and may be able to make and receive calls. (Whether or not the MS can make and receive calls depends on the state within the location registration process). The MS monitors received level and the system information and checks whether cell reselection is needed.
- C4 Normal Cell Reselection - This is where the MS has determined that cell reselection is needed and an attempt is being made to reselect a new cell.
- C5 Choose Cell - This is where the MS has returned to idle mode from "connected mode" and is choosing a suitable cell to camp on.
- C6 Any Cell Selection - This is where the MS is unable to camp normally on any cell of the selected PLMN, or cannot obtain service because of certain responses to a location registration (LR) attempt. It is searching for a cell of any PLMN to camp on (so that emergency calls can be made).
- C7 Camped on any Cell - This is where the MS has camped on a cell irrespective of its PLMN identity, so that emergency calls can be made.
- C8 Any Cell Reselection - This is where the MS is attempting to reselect a cell, irrespective of PLMN identity.
- C9 Choose Any Cell - This is where the MS is returning to idle mode, after having entered "connected mode" from the "camped on any cell" state to make an emergency call. It is attempting to find an acceptable cell to camp on.

For detailed description of the behaviour in the above states see GSM 05.08.

4.3.3 List of states for location updating (figure 4)

The states are entered depending on responses to location update (LU) requests.

4.3.4 List of states for location registration (figure 4)

The states are entered depending on responses to location registration (LR) requests. Independent update states exist for GPRS and for non-GPRS operation in MSs capable of GPRS and non-GPRS services.

- L1 Updated - The MS enters this state if an LR request is accepted. The update status is set to "updated". The GPRS and the non-GPRS update state of a MS may enter "updated" as a result of combined signalling or as a result of individual signalling depending on the capabilities of the network.
- L2 Idle, No IMSI - The MS enters this state if an LR request is rejected with cause:
- a) IMSI unknown in HLR;
 - b) illegal ME;
 - c) illegal MS;
 - d) GPRS not allowed;
- or if there is no SIM. All update states of a MS enter this state regardless whether received by individual or combined signalling for events b) and c). Event a) results in "Roaming not allowed" for the non-GPRS update state only. Event a) has no influence on the GPRS update state. Event d) results in "Roaming not allowed" for the GPRS update state only. Event d) has no influence on the non-GPRS update state.
- If a SIM is present, the non-GPRS update status of the SIM is set to "Roaming not allowed" for events a), b) and c).

- L3 Roaming not allowed - The MS enters this state if it receives an LU reject message with the cause:
- a) PLMN not allowed;
 - b) Location area not allowed;
 - c) Roaming not allowed in this location area;
 - d) GPRS services not allowed in this PLMN.

Except from event d) all update states of the MS are set to "Roaming not allowed" regardless whether received by individual or combined signalling. Event d) results in "Roaming not allowed" for the GPRS update state only. Event d) has no influence on the non-GPRS update state. The behaviour of the MS in the roaming not allowed state is dependent on the LR reject cause as shown in table 2. Additionally:

- in automatic mode, "PLMN not allowed" and "roaming not allowed in this location area" cause the Automatic Network Selection procedure of subclause 4.4.3.1A to be started; it is also caused by "GPRS services not allowed in this PLMN" when received by a GPRS MS operating in MS operation mode C;
- in manual mode, "PLMN not allowed" and "roaming not allowed in this location area" cause the Manual Network Selection procedure of subclause 4.4.3.1B to be started; it is also caused by "GPRS services not allowed in this PLMN" when received by a GPRS MS operating in MS operation mode C.

- L4 Not updated - The MS enters this state if any LR failure not specified for states L2 or L3 occurs, in which cases the MS is not certain whether or not the network has received and accepted the LR attempt. The non-GPRS update status on the SIM and/or the GPRS update status are set to "not updated" depending on the specific location registration procedure and their outcome.

4.4 PLMN selection process

4.4.1 Introduction

There are two modes for PLMN selection, automatic and manual. These are described in subclauses 4.4.3 below and illustrated in figures 2a to 2b.

4.4.2 Registration on a PLMN

The MS shall perform registration on the PLMN if the MS is capable of services which require registration. In both automatic and manual modes, the concept of registration on a PLMN is used. An MS successfully registers on a PLMN if:

- a) The MS has found a suitable cell of the PLMN to camp on; and
- b) An LR request from the MS has been accepted in the registration area of the cell on which the MS is camped (see table 1).

Table 1: Effect of LR Outcomes on PLMN Registration

| Location Registration Task State | Registration Status | Registered PLMN is |
|-----------------------------------|---------------------|--|
| Updated | Successful | Indicated in the stored registration area identity |
| Idle, No IMSI | Unsuccessful | No registered PLMN (3) |
| Roaming not allowed: | | |
| a) PLMN not allowed | Unsuccessful | No registered PLMN |
| b) LA not allowed | Indeterminate(1) | No registered PLMN |
| c) Roaming not allowed in this LA | Indeterminate (2) | No registered PLMN |
| Not updated | Unsuccessful | No registered PLMN |

- 1) The MS will eventually either enter a different state when the registration status will be determined, or fail to be able to camp on a cell, when registration will be unsuccessful.
- 2) The MS will select the HPLMN if in automatic mode and will enter Automatic Network Selection Mode Procedure of subclause 4.4.3.1. If in manual mode, the MS will display the list of available PLMNs and follow the Manual Network Selection Mode Procedure of subclause 4.4.3.1. If the appropriate process does not result in registration, the MS will eventually enter the limited service state.
- 3) A MS may have different update states for GPRS and non-GPRS. A PLMN is registered when at least one of both update states is updated.

NOTE 1: MSs capable of GPRS and non-GPRS services may have different registration status for GPRS and for non-GPRS.

NOTE 2: The registered PLMN is determined by looking at the stored registration area identity and stored location registration status.

It should be noted that if registration is unsuccessful because no suitable cell could be found, the MS will have had to search at least the number, given in subclause 3.2.1, of the strongest RF channels (see subclause 3.2) and therefore all the available PLMNs will potentially have been detected. If registration is unsuccessful because of an LR failure or an LR rejection, the MS need not necessarily have already searched the number, given in subclause 3.2.1, of the strongest RF channels, and would need to do so before being in a position to display to the user all available PLMNs (see below).

4.4.3 PLMN selection

The registration on the selected PLMN and the location registration are only necessary if the MS is capable of services which require registration. Otherwise, the PLMN selection procedures are performed without registration.

4.4.3.1 At switch-on or recovery from lack of coverage

At switch on, the MS selects and attempts to perform a Location Registration on the registered PLMN, if it exists. On recovery from lack of coverage, the MS selects the registered PLMN (if it exists) and, if necessary (see subclause 4.6.2) attempts to perform a Location Registration.

If successful registration is achieved, the MS indicates the selected PLMN.

If there is no registered PLMN, or if registration is not possible due to the PLMN being unavailable or registration failure, the MS follows one of the following two procedures depending on its operating mode.

EXCEPTION: If registration is not possible on recovery from lack of coverage due to the registered PLMN being unavailable, a MS attached to GPRS services may, optionally, continue looking for the registered PLMN for an implementation dependent time.

NOTE: A MS attached to GPRS services should use the above exception only if one or more PDP contexts are currently active.

A) Automatic Network Selection Mode Procedure

The MS selects and attempts registration on other PLMNs, if available and allowable, in all of its bands of operation in the following order:

- i) HPLMN (if not previously selected);

- ii) each PLMN in the "PLMN Selector" data field in the SIM (in priority order);
- iii) other PLMNs with received signal level above -85 dBm in random order;
- iv) all other PLMNs in order of decreasing signal strength.

If successful registration is achieved, the MS indicates the selected PLMN.

If registration cannot be achieved because no PLMNs are available and allowable, the MS indicates "no service" to the user, waits until a new PLMN is available and allowable and then repeats the procedure.

If there were one or more PLMNs which were available and allowable, but an LR failure made registration on those PLMNs unsuccessful or an entry in a forbidden LAI list prevented a registration attempt, the MS selects the first such PLMN again and enters a limited service state.

B) Manual Network Selection Mode Procedure

The MS indicates whether there are any PLMNs, in all of its bands of operation, which are available. This includes "Forbidden PLMNs". Any PLMN shall only be presented once.

If displayed, PLMNs meeting the criteria above are presented in the following order:

- i) HPLMN;
- ii) PLMNs contained in the "PLMN Selector" data field in the SIM (in priority order);
- iii) other PLMNs with received signal level above -85 dBm in random order;
- iv) all other PLMNs in order of decreasing signal strength.

The user may select his desired PLMN and the MS then initiates registration on this PLMN. (This may take place at any time during the presentation of PLMNs). For such a registration, the MS shall ignore the contents of the forbidden LAI lists, "forbidden PLMNs for GPRS service" lists and forbidden PLMN lists.

If the user does not select a PLMN, the selected PLMN shall be the one that was selected before the PLMN selection procedure started. If no such PLMN was selected or that PLMN is no longer available, then the MS shall attempt to camp on any acceptable cell and enter the limited service state.

4.4.3.2 User reselection

At any time the user may request the MS to initiate reselection and registration onto an available PLMN, according to the following procedures, dependent upon the operating mode.

A) Automatic Network Selection Mode

The MS selects and attempts registration on PLMNs, if available and allowable, in all of its bands of operation in accordance with the following order:

- i) HPLMN;
- ii) PLMNs contained in the "PLMN Selector" data field in the SIM (in priority order) excluding the previously selected PLMN;
- iii) Other PLMNs with the received signal level above -85 dBm in random order excluding the previously selected PLMN;
- iv) Any other PLMNs, excluding the previously selected PLMN in order of decreasing signal strength or, alternatively, the previously selected PLMN may be chosen ignoring its signal strength;
- v) The previously selected PLMN.

The previously selected PLMN is the PLMN which the MS has selected prior to the start of the user reselection procedure

B) Manual Network Selection Mode

The Manual Network Selection Mode Procedure of subclause 4.4.3.1 is followed.

4.4.3.3 In VPLMN of home country

The MS shall periodically attempt to obtain service on its HPLMN. For this purpose, a value T minutes may be stored in the SIM, T is either in the range 6 minutes to 8 hours in 6 minute steps or it indicates that no periodic attempts shall be made. If no value is stored in the SIM, a default value of 30 minutes is used.

The attempts to access the HPLMN shall be as specified below:

- a) The periodic attempts shall only be performed in automatic mode when the MS is roaming in its home country;
- b) After switch on, a period of at least 2 minutes and at most T minutes shall elapse before the first attempt is made;
- c) The MS shall make an attempt if the MS is on the VPLMN at time T after the last attempt;
- d) Periodic attempts shall only be performed by the MS while in idle mode;
- e) If the HPLMN is not found, the MS shall remain on the VPLMN.

4.4.4 Abnormal cases

If there is no SIM in the MS, if there is an authentication failure, or if the MS receives an "IMSI unknown in HLR", "illegal ME" or "illegal MS" response to an LR request, then effectively there is no selected PLMN ("No SIM" state). In these cases, the states of the cell selection process are such that no PLMN selection information is used. No further attempts at registration on any PLMN are made until the MS is switched off and on again, or a SIM is inserted.

When in Automatic Network Selection mode and the MS is in the "not updated" state with one or more suitable cells to camp on; then after the maximum allowed unsuccessful LR requests (controlled by the specific attempt counters) the MS may continue (or start if it is not running) the user reselection procedure of 4.4.3.2 A.

4.4.5 Roaming not allowed in this LA

If in either PLMN selection mode the LR response "Roaming not allowed in this LA" is received:

- The PLMN Automatic or Manual Mode Selection Procedure of subclause 4.4.3.1 are followed, depending on whether the MS is in automatic or manual mode. (This requirement applies to all MSs).

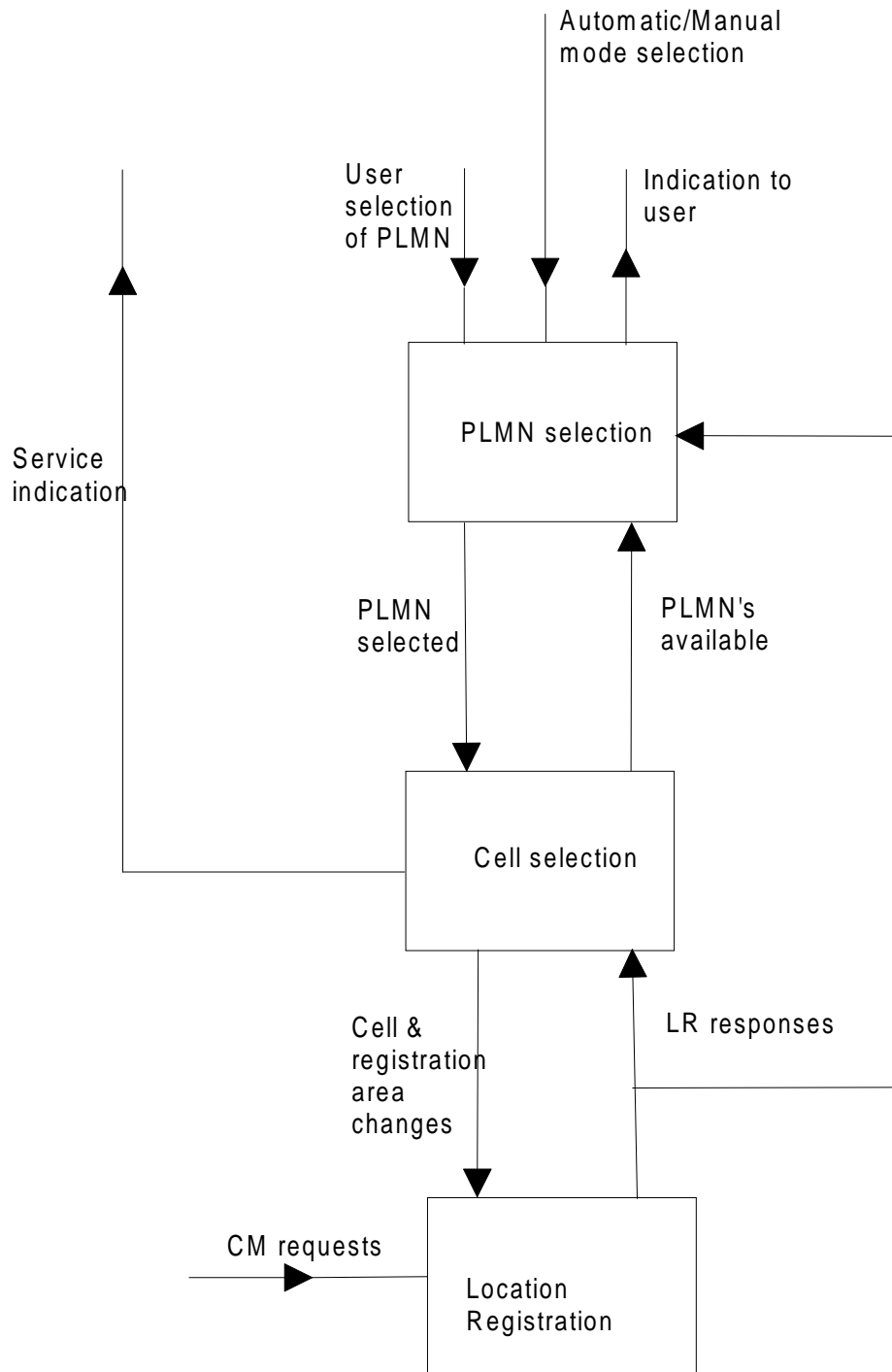
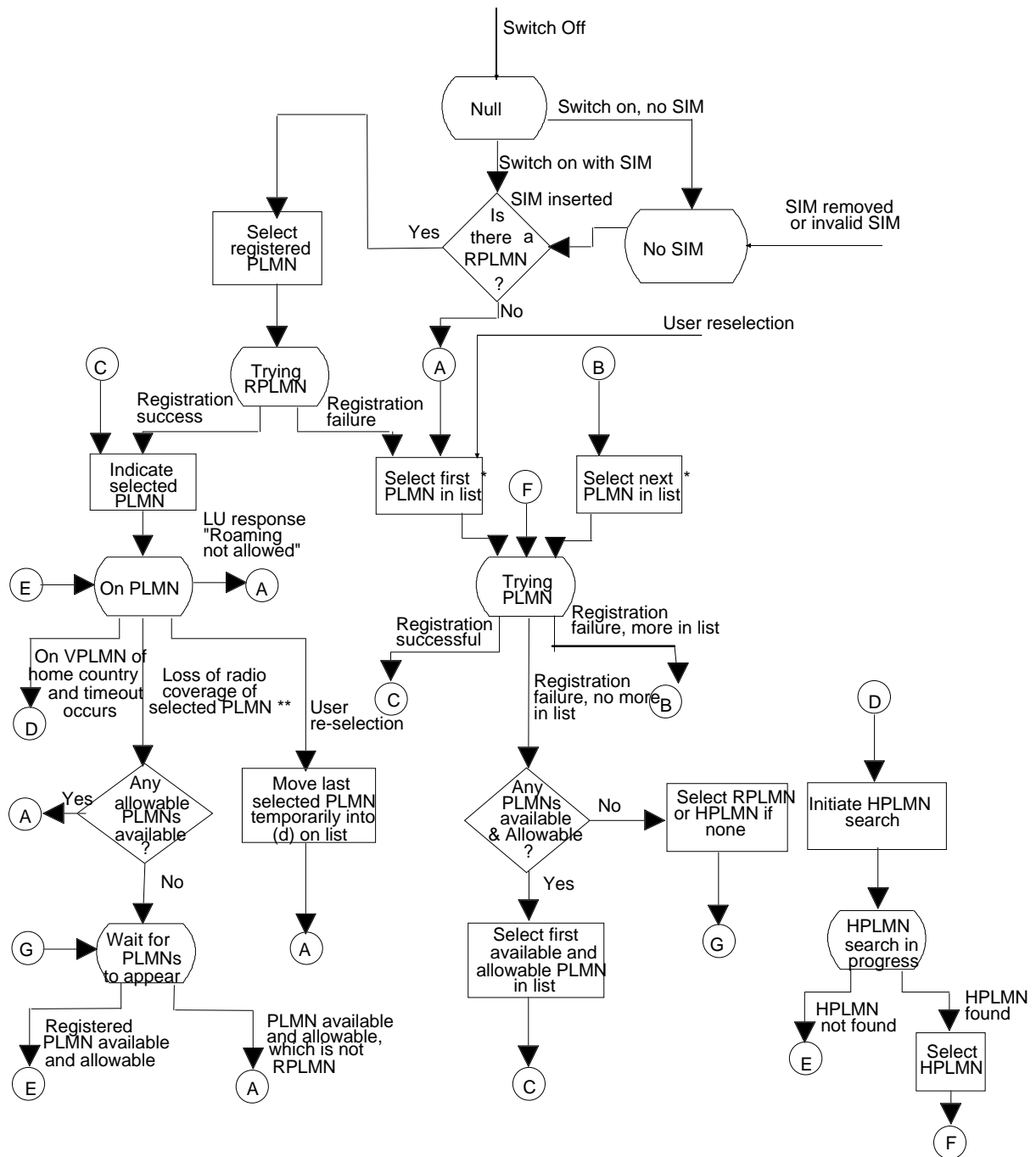

Figure 1: Overall Idle Mode process



* "List" consists of (in order)

- a) HPLMN
 - b) Each PLMN in SIM list in priority order
 - c) All other PLMNs above -85 dBm in random order
 - d) Other PLMNs in decreasing order of signal strength
-) Provided they are "available" and "allowable"

** Includes effective loss of coverage due to LAs being forbidden in all potentially suitable cells

Figure 2a: PLMN Selection State diagram (automatic mode)

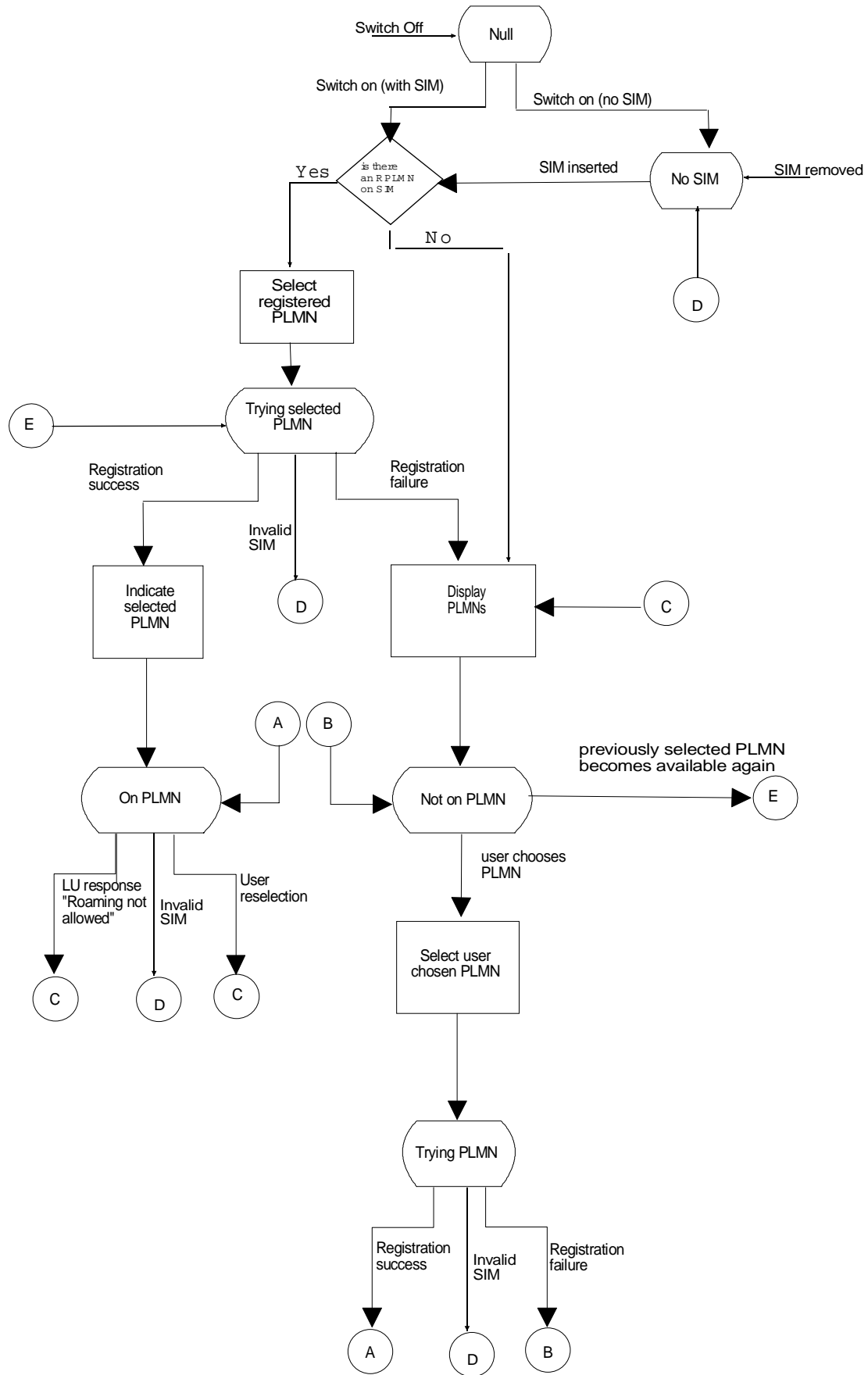

Figure 2b: PLMN Selection State diagram (manual mode)

4.5 Cell selection process

Whenever a PLMN is selected, the MS attempts to find a suitable cell of that PLMN to camp on. Two methods of searching for a suitable cell are possible:

- a) Normal cell selection ("Normal cell selection" state) - Here the MS has no prior knowledge of which RF channels are BCCH carriers. It searches at least the number, given in subclause 3.2.1, of the strongest RF channels in descending order of received signal level to see which are BCCH carriers. (If no BCCH carriers have yet been found, searching will continue until at least one BCCH carrier is found.). The first BCCH carrier found which is from a suitable cell and on which there is a normal priority indication is taken and that cell is camped on. If at least the number, given in subclause 3.2.1, of the strongest RF channels have been tried and the only suitable cells found have low priority indication the MS shall camp on the strongest of these cells.
- b) Stored list cell selection (optional) ("Stored list cell selection" state) - Here the MS has a list of the BCCH carriers used by the PLMN. (This list may be derived by the MS from information gathered during previous selections of the PLMN). The BCCH carriers in the list are searched in descending order of received signal level, and the first BCCH carrier found which is from a suitable cell and on which there is a normal priority indication is taken, and that cell is camped on. If an MS decodes BCCH data from a cell of the selected PLMN but is unable to camp on that cell, the BA of that cell shall be examined and any BCCH carriers in the BA which are not in the list of BCCH carriers to be searched shall be added to the list. If all these BCCH carriers have been tried and the only suitable cells found have low priority indication, the MS shall camp on the strongest of these cells.

If no suitable cell is found using method b), method a) is then tried.

While camped on a cell of the selected PLMN ("camped normally"), the MS may need to select a different cell ("normal cell reselection" state). The following events trigger a cell reselection:

- i) The path loss criterion parameter C1 (see subclause 3.6) indicates that the path loss to the cell has become too high;
- ii) There is a downlink signalling failure (subclause 3.6);
- iii) The cell camped on (current serving cell) has become barred;
- iv) There is a better cell (in terms of the path loss criterion C2) in the same registration area, or a much better cell in another registration area of the selected PLMN (using the CRH parameter, subclause 3.4);
- v) A random access attempt is still unsuccessful after "Max retrans" repetitions; "Max retrans" being a parameter broadcast on control channel.

A GPRS MS in Ready state applies the READY_STATE CELL RESELECTION HYSTERESIS together with the path loss criterion when reselecting the cell within the registration area. The GPRS MS in Ready state shall inform the network about cell reselection within the registration area by the cell update procedure. The network may control cell reselection of a GPRS MS in Ready state (GSM 03.64).

Instead of the parameter C2, a GPRS MS applies the corresponding GPRS parameter if provided. If this GPRS parameter is provided the cell shall also broadcast a list BA(GPRS) indicating BCCH carriers to be monitored by GPRS MSs for cell re-selection purpose.

An MS supporting SoLSA with SoLSA subscription shall use the SoLSA cell re-selection parameters.

The MS will then reselect a new cell in order to fulfil the process goal (see subclause 4.1).

Before camping on the cell after re-selection, the MS shall attempt to decode the full set of system information. The MS shall check that the parameters affecting cell re-selection are unchanged. If a change is detected the MS shall check if the cell re-selection criterion is still valid using the changed parameters. If the cell selection criteria are still valid, the MS shall camp on the cell. If they are not still valid, the MS shall repeat this process for the cell with the next highest value of C2 or corresponding GPRS parameter or SoLSA parameters, respectively.

Once the MS has re-tuned to the chosen cell, it shall monitor its paging subgroup (if known) for that cell. If the MS and the cell support group or broadcast calls, it shall also monitor the notification channel. A GPRS MS shall monitor the relevant GPRS control channel(s). If the MS receives a page before having decoded the relevant system information for the new cell, the MS shall store the page and respond, if permitted, once the relevant system information has been decoded. If not permitted, no page response shall be made.

When the MS leaves idle mode and enters "connected mode" (e.g., to make a call), on return to idle mode at the end of the call, a cell must be chosen ("choose cell" state) as soon as possible e.g., to allow a new call to be made as soon as possible. The chosen cell will not necessarily be the same cell as the MS was camped on when the call started e.g., if the MS moved a significant distance while the call was in progress. Two cases are distinguished in GSM 05.08, for which the algorithm is slightly different:

- a) Normal case - The call is terminated, either because the user (or network) has terminated the call, or because a radio link failure has occurred and call re-establishment is not being attempted.
- b) Call re-establishment - A radio link failure has occurred and a call re-establishment is being attempted. (The MS returns to idle mode to start the call re-establishment attempt and needs to select a new cell on which to make the attempt as soon as possible in order to minimize the interruption to the call).

If no suitable cell is found by either the stored list cell selection, normal cell reselection, or choose cell tasks (all of which use a limited search), the normal cell selection task (which searches all RF channels for a suitable cell) is entered.

If no suitable cell is found by the normal cell selection task, or if there is no SIM in the MS, the MS attempts to find an "acceptable cell" on which it may camp so that emergency calls may be made ("any cell selection" state). The MS ignores the PLMN information when selecting an acceptable cell, and no attempt at location registration is made. This task is also entered if an LR reject is received with one of the following cause values:

- "IMSI unknown in HLR" (only for non-GPRS MS as this impacts only the non-GPRS update state, MSs capable of GPRS and non-GPRS services take a cell selection state according to the outcome of the routing area update);
- "Illegal MS";
- "illegal ME";
- "PLMN not allowed" (However, this will trigger a new PLMN selection if the MS is in automatic mode);
- "GPRS services not allowed in this PLMN" (only for GPRS MS operating in MS operation mode C, where this will trigger a new PLMN selection if the MS is in automatic mode; a GPRS MSs operating in MS operation mode A or B take a cell selection state according to the outcome of location updating as "GPRS services not allowed in this PLMN" has only impact on the GPRS update status).

If an acceptable cell is found, the MS camps on it ("Camped on any cell" state). If one of the cell reselection trigger events (i) to (v) above occurs, the MS attempts to find a new acceptable cell to camp on ("any cell reselection" state) but using a zero dB value of CRH. If no acceptable cell can be found, the "any cell selection" task is re-entered.

If while camped on an acceptable cell, an emergency call origination is made, the MS enters a connected mode and at the end of the call, chooses an acceptable cell ("choose any cell" state) so that it is ready for the next emergency call origination.

In all cases, if a new PLMN is selected, the MS searches for a suitable cell of that PLMN. However, if the MS has recently searched the strongest RF channels while a previous PLMN was selected, it may already have information about other PLMNs.

The user may request a search of RF channels to determine which PLMNs are available. This search shall be done in such a way as to minimize interruptions to the MS's monitoring of its paging subchannel.

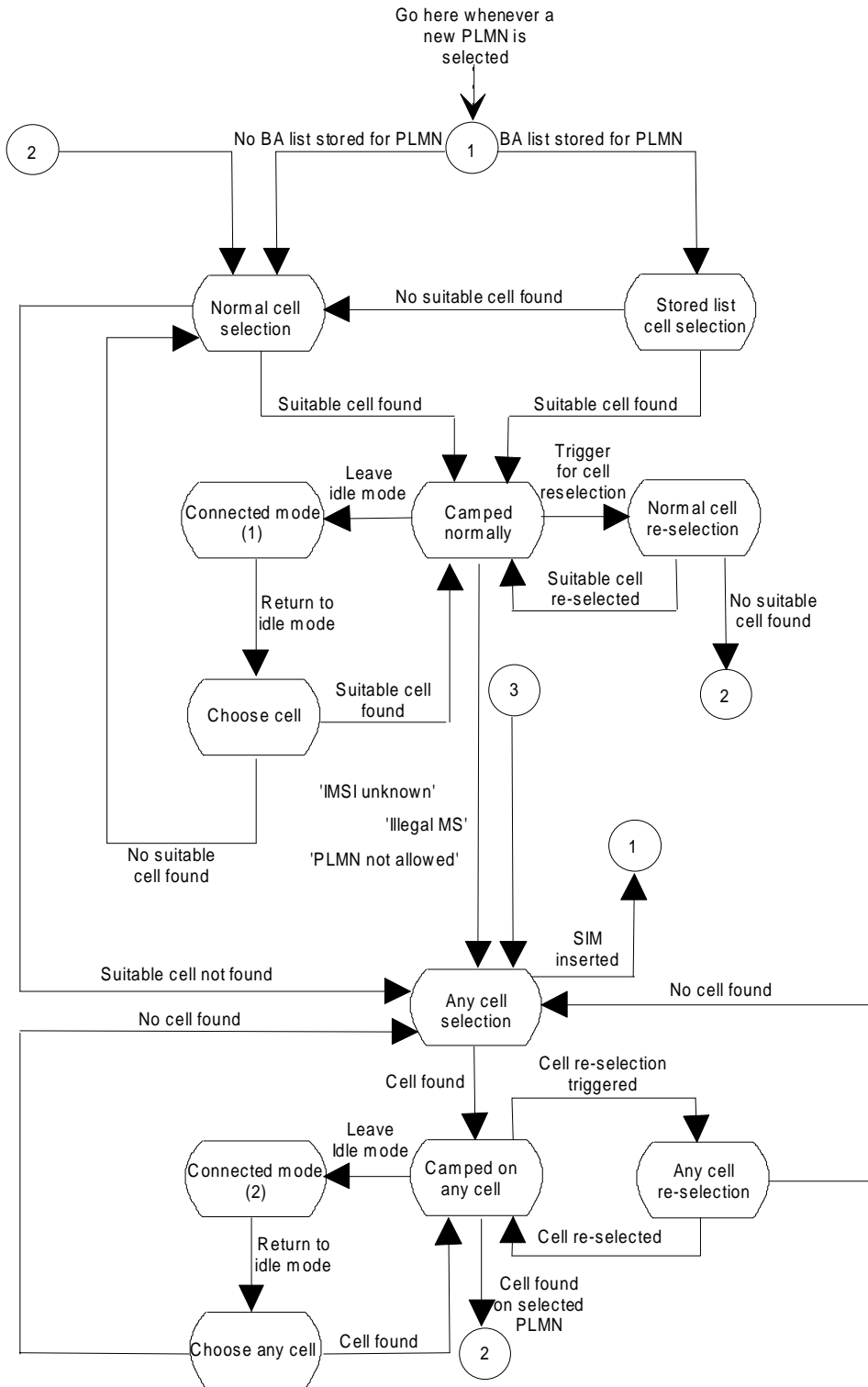

NOTE 1: To make or receive call.
 NOTE 2: To make an emergency call;
 In any state, a new PLMN selection causes an exit to 1;
 Go to 3 if no SIM in MS.

Figure 3: Cell Selection State diagram

4.6 Location registration process

4.6.1 General

When the MS is switched on and capable of services requiring registration, the action taken by the location registration process is as follows:

- a) SIM present and no LR needed (because of the status of the stored registration area identity and "attach" flag):
The MS is in the update state UPDATED;
- b) SIM present and LR needed: A LR request is made;
- c) No SIM present: The MS enters the update state Idle, NO IMSI.

In case b) above, and subsequently whenever a LR request is made, the MS enters a state depending on the outcome of the LR request, as listed in subclause 4.3.3 above. In case c) the GPRS and the non-GPRS update state enters "IDLE, NO IMSI".

Whenever the MS goes to connected mode and then returns to idle mode again, the MS selects the appropriate state.

4.6.2 Initiation of Location Registration

An LR request indicating Normal Updating is made when, in idle mode,

- the MS changes cell while being in the update state NOT UPDATED; (for MS capable of GPRS and non-GPRS services when at least one of both update states is NOT UPDATED)
- the MS detects that it has entered a new registration area, i.e., when the received registration area identity differs from the one stored in the MS, and the LAI or the PLMN identity is not contained in a list of forbidden LAIs, "forbidden PLMNs for GPRS service" or forbidden PLMN identities respectively, while being in one of the following update states:
 - UPDATED;
 - NOT UPDATED;
 - ROAMING NOT ALLOWED.
- the Periodic Location Updating Timer expires while being in the non-GPRS update state NOT UPDATED (triggers Location Updating);
- the Periodic Routing Area Update timer expires while being in the GPRS update state NOT UPDATED (triggers Routing Area Update);
- a manual network reselection has been performed, an acceptable cell of the selected PLMN is present, and the MS is not in the UPDATED state on the selected PLMN.

An LR request indicating Periodic Location Updating is made when, in idle mode, the Periodic Location Updating timer expires while being in the non-GPRS update state UPDATED.

An LR request indicating Periodic Routing Area Update is made when the Periodic Routing Area Update timer expires while being in the GPRS update state UPDATED.

An LR request indicating IMSI attach is made when the MS is activated in the same location area in which it was deactivated while being in the non-GPRS update state UPDATED, and the system information indicates that IMSI attach/detach shall be used.

A GPRS attach is made by a GPRS MS when activated and capable of services which require registration. A GPRS attach may only be performed if the selected PLMN is not contained in the list of "forbidden PLMNs for GPRS service". Depending on system information about GPRS network operation mode MSs operating in MS operation mode A or B perform combined or non-combined location registration procedures. When the combined routing area update or GPRS attach is accepted with indication "MSC not reachable" or is not answered the MS performs also the corresponding location updating procedure or falls back to a GPRS only MS. When the combined routing area update or GPRS attach

is rejected with cause "GPRS not allowed" the GPRS update state is "IDLE, NO IMSI" and the MS performs the corresponding location updating procedure.

Furthermore, an LR request indicating Normal Location Updating is also made when the response to an outgoing request shows that the MS is unknown in the VLR or SGSN, respectively.

Table 2 summarizes the events in each state that trigger a new LR request. The actions that may be taken while being in the various states are also outlined in table 2.

Table 2: LR Process States and Allowed Actions

| Location registration task state | New LR request when | | | | Normal Calls Supported (1) | Paging responded to |
|--|---------------------|----------------------------------|------------------|---------|-------------------------------|---------------------------|
| | Changing Cell | Changing registration area | Changing PLMN | Other | | |
| Null (4) | No | Yes | Yes | No | No | No |
| Updated, (5) | No | Yes | Yes | (2) | Yes | Yes |
| Idle, No IMSI (7) | No | No | No | No | No | No |
| Roaming not allowed: a) Idle, PLMN not allowed | No | No | Yes | No | No | Optional if with IMSI |
| b) Idle, LA not allowed | No | Yes(6) | Yes | No | No | Optional if with IMSI |
| c) Idle, Roaming not allowed in this LA | No | Yes(6) | Yes | No | No | Optional if with IMSI |
| Not updated | Yes | Yes | Yes | (2)&(3) | (3) | Yes if with IMSI |

- 1): Emergency calls may always be made, subject to access control permitting it.
- 2): A new LR is made when the periodic registration timer expires.
- 3): If a normal call request is made, an LR request is made. If successful the updated state is entered and the call may be made.
- 4): The MS is in the null state from switch on until it has camped on a cell and either made an LR attempt or decided that no LR attempt is needed.
- 5): In this state, IMSI detach is performed if the MS is deactivated and the BCCH indicates that IMSI attach/detach shall be used. An LR request indicating IMSI attach is performed if the MS is activated in the same registration area in which it was deactivated while being in this state.
- 6): A GPRS MS shall not perform a new LR when the new routing area is part of a LA contained in a list of forbidden LA.
- 7): The GPRS registration status "Idle, no IMSI" is entered when LR is rejected with cause "GPRS not allowed". The non-GPRS registration status „Idle, no IMSI" is entered when the cause "IMSI unknown in HLR" is received.

A GPRS MS which is both IMSI attached for GPRS and non-GPRS services and which is capable of simultaneous operation of GPRS and non-GPRS services shall perform Routing Area Update in connected mode when it has entered a new routing area which is not part of a LA contained in the list of forbidden LAIs.

4.6.3 Periodic Location Registration

A Periodic Location Updating timer (for non-GPRS operation) and a Periodic Routing Area Update timer (for GPRS operation) with the following characteristics shall be implemented in the MS (MS capable of GPRS and non-GPRS operation shall implement both timers):

- i) Upon switch on of the MS or when the system information indicates that periodic location registration shall be applied, and the timer is not running, the timer shall be loaded with a random value between 0 and the broadcast or signalled time-out value and started.
- ii) The time-out value for the Periodic Location Updating timer shall be within the range of 1 deci-hour to 255 deci-hours with a granularity of 1 deci-hour.
- iii) When the timer reaches its expiry value, it shall be initiated with respect to the relevant time-out value, and the MS shall initiate the Periodic Location Registration corresponding to the expired timer.
- iv) The Periodic Location Updating timer shall be prevented from triggering Periodic Location Updating during connected mode. When the MS returns to idle mode, the Periodic Location Updating timer shall be initiated with respect to the broadcast time-out value, then started. Thereafter, the procedure in iii) shall be followed.
- v) The Periodic Routing Area Update timer shall be prevented from triggering the Periodic Routing Area Update during Ready state. At transition from Ready to Standby state the Periodic Routing Area Update timer shall be initiated with respect to its time-out value, then started. Thereafter, the procedure in iii) shall be followed.
- vi) If the MS performs a successful combined Routing Area Update the Periodic Location Updating timer shall be prevented from triggering the Periodic Location Updating until the MS starts using Location Updating procedure, for example because of a changed network operation mode or the MS uses non-GPRS services only.
- vii) When a change in the time-out value occurs (at a change of serving cell or a change in the broadcast time-out value or a change in the signalled time-out value), the related timer shall be reloaded so that the new time to expiry will be: "old time to expiry" modulo "new time-out value".

4.6.4 IMSI attach/detach operation

The system information will contain an indicator indicating whether or not IMSI attach/detach operation is mandatory to use in the cell. The MS shall operate in accordance with the received value of the indicator.

A GPRS MS shall perform GPRS attach/detach procedures independent of the value of the IMSI attach/detach indicator. When a GPRS MS has to perform IMSI attach/detach independent of GPRS procedures (for example GPRS network operation mode 2) the handling described in the paragraph above applies.

When IMSI attach/detach operation applies, a MS shall send the IMSI detach message to the network when the MS is powered down or the SIM is removed while being in the update state UPDATED. The IMSI detach message will not be acknowledged by the network.

When the MS returns to the active state, the MS shall perform an LR request indicating IMSI attach, provided that the MS still is in the same registration area. If the registration area has changed, an LR request indicating Normal Location Updating according to subclause 4.6.2 shall be performed.

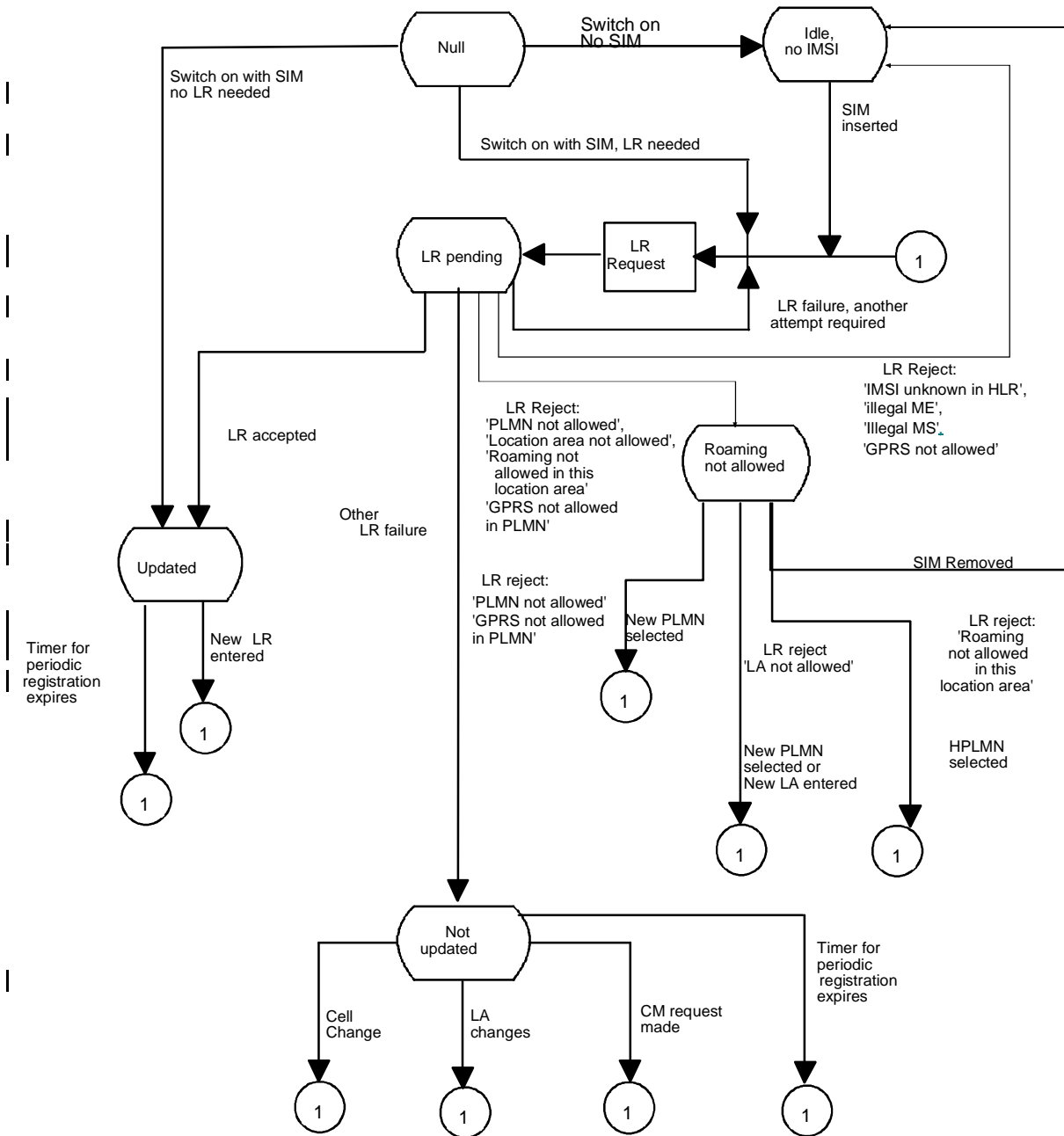

NOTE: Whenever the MS goes to connected mode and then returns to idle mode again the MS selects appropriate state.
 A MS capable of GPRS and non-GPRS services has two Task State machines one for GPRS and one for non-GPRS operation.

Figure 4: Location Registration Task State diagram

4.7 Service indication

This is an indication to the user that service or CTS service is available.

The service indication should be set if the following conditions are all satisfied:

- Cell Selection: Camped on a suitable cell and in updated state, or in connected mode having been camped on a suitable cell.
- Location registration: In updated state, for MSs capable of services requiring registration.

A specific CTS service indication should be set when the CTS MS is attached to a CTS FP.

However due to the fact that there may be some transitory changes of state, the service indication is permitted to continue to be set for up to 10 seconds after the above conditions cease to be met. Also the service indication is permitted to take up to 1 second to be set after the above conditions are met.

4.8 BCCH allocation broadcasting and storage

The BCCH allocation is the list of BCCH carriers in use by a given PLMN in a given geographical area. (It indicates the RF channels that the MS is required to monitor while camped on a cell of that PLMN.) It is broadcast in the system information messages on the BCCH, and is referred to as the BA(BCCH).

When the MS is first switched on in a PLMN, and has no knowledge of which RF channels are BCCH carriers of that PLMN it has to search the strongest RF channels in order to find which are BCCH carriers. It then has to determine which BCCH carriers belong to the selected PLMN. Once it has found a BCCH carrier of the selected PLMN, it can read the BA(BCCH). It then knows which RF channels to monitor for cell selection and reselection purposes.

Cells supporting GPRS may broadcast a list BA(GPRS) as system information. It indicates the BCCH carriers to be monitored by a GPRS MS for cell re-selection.

Whilst switched on in the PLMN, the MS can gain knowledge of the preferable carriers to use in subsequent cell selections in that PLMN. This knowledge may come from previously decoded BA(BCCH)s and from transmitted information from the network.

When the MS switches off, it has the option of storing the last known BA(BCCH) in a non volatile store so that on a subsequent switch on in that PLMN, it does not need to search to find the BA(BCCH), and so can camp on a cell more quickly. If the BA(BCCH) is stored in the SIM, it shall be stored in the format specified in GSM 11.11. Any other information used by the MS in cell selection shall be stored in a non volatile store on the ME.

The BA(BCCH) may or may not be the total list of BCCH carriers in use throughout the PLMN coverage area. For example there may be differences in different geographical areas, and there may be "umbrella cells" which are only used for hand over traffic and hence are not to be camped on.

NOTE: The PLMN operator cannot expect the ME to store the BCCH carrier frequency of the serving cell in the SIM unless the BA(BCCH) includes the BCCH carrier frequency on which it is broadcast.

A stored BA(BCCH) is not necessarily valid when the MS is switched on again e.g., if the system operator has made a change in BA(BCCH) or if the MS is switched on in a different geographical area. In these cases, the MS may not find a suitable cell for camping on using the stored BA(BCCH). However, the MS may use other stored information to find a suitable cell before searching all the strongest RF channels to find a suitable cell of the selected PLMN.

It should also be noted that the BA(BCCH) only applies to the PLMN on which it was received. If a new PLMN is selected, only a BA(BCCH) previously obtained from that PLMN should be used.

There is another BCCH carrier list, called BA(SACCH), which is sent on the SACCH when in connected mode. This contains the list of BCCH carriers to be monitored by the MS for hand over purposes. The BA(BCCH) and BA(SACCH) need not necessarily be the same. For example, the BA(SACCH) might contain umbrella cells, or the BCCH carrier of the serving cell might be omitted.

If the MS stores a BA list in the SIM, and there is a valid stored LAI, the BA list must be of the PLMN indicated by the stored LAI.

4.9 Pageability of the mobile subscriber

An MS is required to listen to all paging messages that could address it (see GSM 05.02), when the following conditions are all satisfied:

- A SIM is inserted.
- The MS is camped on a cell.
- The MS is not in state "Idle, No IMSI".
- The MS is not performing the task to search for available PLMNs. (Whenever possible during this task, the MS should listen for paging.). However, when the MS is camped on a cell, is registered in a PLMN and is

performing its regular search for the HPLMN, as specified in GSM 02.11, then it shall listen to all paging messages that could address it.

NOTE 1: During cell reselection there is a certain period when the MS is no longer camped on the old cell but must decode the full BCCH before camping on the new cell. This leads to a period of slightly more than 8 51 frame multiframe when the MS will not necessarily be pageable.

4.10 MM Restart Procedure

In some cases, e.g. on change of SIM data, there is a need for the MM to be restarted without the need for user intervention.

To perform the procedure the MS shall behave as if the SIM is removed and afterwards a new SIM is inserted.

5 Group receive mode

5.1 General description

The purpose of the group receive mode process is for a MS to determine the most suitable cell while listening to a group or broadcast call.

There are various requirements that a cell must satisfy before an MS can perform group receive mode on it:

- i) The radio path loss between MS and BTS must be below a threshold set by the PLMN operator. This is estimated as shown in subclause 3.6. That means that the cell is suitable for transmission and reception.
- ii) It should not be "barred" (see subclause 3.5.1);
- iii) The NCC of the PLMN should be permitted;

The choice of a cell is based on the C2 criterion, as defined in GSM 05.08. . When in group receive mode on a cell the MS regularly looks to see if there is a better cell in terms of the cell reselection criterion C2, as defined in GSM 05.08. C2 is determined by the MS from reception measurements on the BCCH frequency on the cell and reselection parameters relative to the cell. The reselection parameters are the same as those used in idle mode.

If there is a better cell which is suitable, the better cell is selected. (This is called "cell reselection in group receive mode").

The switching from idle or dedicated or group transmit mode to group receive mode is controlled by the Radio Interface Layer 3 protocols, see GSM 04.08.

If no suitable cell can be found the MS immediately returns to idle mode by choosing a cell like releasing a dedicated channel (see 05.08 subclause 6.7.1).

5.2 Requirements and technical solutions

5.2.1 Network provisions

For group and broadcast calls, the network provides a BA list in the SI TYPE 5, 5bis or 5ter message on the SACCH of the channel used for the group or broadcast call. The BA list indicates the BCCH carriers of the surrounding cells that MSs engaged in the call should monitor. The list shall include the cell on which it is sent. The cells in the list may belong to different PLMNs.

The network also provides the SI TYPE 6 message including an NCC permitted information element on the SACCH of the channel used for the group or broadcast call.

5.2.2 Group receive mode cell monitoring

A MS in group receive mode shall perform synchronization, identification and receive signal strength measurements of the BCCH carriers in the BA(SACCH) list of BCCH frequencies which was provided by the network in the serving cell. The regularity for performing synchronization and identification of the BCCH carriers shall be performed with a regularity as specified in GSM 05.08 for a MS in dedicated mode. The regularity of performing receive signal strength measurements of the BCCH carriers shall be as specified in GSM 05.08 for a MS in idle mode.

As long as no BA(SACCH) list is available on the SACCH, the last received BA(BCCH) list of the current cell shall be used instead if available.

The MS does not have to monitor cells for which NCC is not permitted. The NCC permitted information is provided on the SACCH of the current cell. As long as no NCC permitted information is available on the SACCH, the last received NCC permitted information on the BCCH of the current cell shall be used instead if available.

The MS must also read the parameters affecting cell reselection of the surrounding cells from their respective BCCHs. These parameters are:

- MS txpwr max cch;
- rxlev access min;
- cell reselect offset;
- temporary offset;
- penalty time;
- location identity.

The MS shall attempt to decode this information within 15s after there are less than six stronger suitable cells and the MS is allowed to discard up to 6 speech frames during this period. The MS shall attempt to update the information at least every five minutes. Before selecting a cell in group receive mode the MS must have read the information which is presented in SI TYPE 1 and 3.

On this basis, the MS determines which of the cells in the list are suitable and computes their reselection criterion, and decides on its own whether one of the surrounding cells should be selected instead of the current one, as described in the next subclause.

The procedures above do not consider whether the cell supports the call or not.

To perform cell change, the MS shall at least have performed measurements on cells of the BA-list received and read the corresponding BSIC.

5.2.3 Group receive mode cell change

Either of the following events trigger a cell change by a MS in group receive mode:

- (i) The path loss parameter C1 indicates that the path loss to the serving cell has become too high.
- (ii) There is a radio link time-out.
- (iii) There is a better cell (in terms of the criterion C2) in the same LA, or a much better cell in another LA (using CRH parameter, subclause 3.4) and with NCC permitted.

After cell change, the MS either

- leaves the group receive mode and goes to idle mode in order to establish a dedicated connection with the network to perform a location update if the cell belongs to a new LA
- detects that the selected cell belongs to another PLMN and therefore leaves the group receive mode and goes to idle mode;
- detects that no NCH is present and therefore leaves the group receive mode and goes to idle mode;
- reads the NCH but does not receive any notification message for the current group or broadcast call and therefore leaves the group receive mode and goes to idle mode;
- reads the NCH and receives a notification message for the current group or broadcast call with the related channel position. If the channel is found, the MS changes to it and stays in group receive mode;
- reads the NCH and receives a notification message for the current group or broadcast call without information on the related channel position. The MS leaves the group receive mode and goes to idle mode in order to establish a dedicated connection with the network to become informed on the related channel position.

During these procedures, the MS may not be able to listen to the group or broadcast call, in which case it should mute the downlink.

For all procedures, which require that the MS leaves group receive mode, the MS goes to idle mode by choosing a cell like releasing a dedicated channel (see GSM 05.08 subclause 6.7.1).

5.2.4 Uplink access in group calls

A MS assigned the uplink for the user to talk switches to group transmit mode.

It thus performs synchronisation, identification and measurements of the BCCH carriers according to the BA(SACCH) list as well as radio link measurements and reporting and is subject to hand over control from the network as for dedicated mode.

Annex A (normative): HPLMN Matching Criteria

With the introduction of PCS1900 with the regulatory mandate to allocate 3-digit MNC codes, additional functionality is required to identify the HPLMN.

Assumptions

An MNC code shall consist of 2 or 3 decimal digits. In NA PCS1900, all SIMs shall store 3 digit MNCs.

Any network using a 2 digit MNC code shall broadcast the hexadecimal code "F" in place of the 3rd digit.

For PCS1900 for North America, regulations mandate that a 3-digit MNC shall be used; however during a transition period, a 2 digit MNC may be broadcast by the Network and, in this case, the 3rd digit of the SIM is stored as 0 (this is the 0 suffix rule).

With the exception of North America during the transition period:

- a) Within a single country (or area identified by a MCC) all networks shall broadcast a 2 digit MNC code, or all networks shall broadcast a 3 digit MNC code. A mixture of broadcast 2 and 3 digit MNC codes is not permitted within a single country (or area identified by a MCC).
- b) A network which broadcasts a 2 digit MNC code, will issue SIMs with a 2 digit MNC code in the IMSI on the SIM. A network which broadcasts a 3 digit MNC code, will issue SIMs with a 3 digit MNC code in the IMSI on the SIM.

Definitions and abbreviations

| | |
|-----------------|--|
| BCCH-MCC | The MCC part of the LAI read from System Information type 3 messages broadcast on the BCCH by the network. |
| BCCH-MNC | The MNC part of the LAI read from System Information type 3 messages broadcast on the BCCH by the network. |
| SIM-MCC | The MCC part of the IMSI read from the SIM. |
| SIM-MNC | The MNC part of the IMSI read from the SIM. |

HPLMN Matching Criteria in mobiles which don't support PCS1900 for NA:

Figure A.1 illustrates the logic flow described below. The text below is normative. The Figure A.1 is informative.

- (1) The MS shall compare using all 3 digits of the SIM-MCC with the BCCH-MCC. If the values do not match, then the HPLMN match fails.

NOTE: If the MCC codes match, then the number of digits used for the SIM-MNC must be the same as the number of digits used for the BCCH-MNC.

- (2) The MS shall read the 3rd digit of the BCCH-MNC. If the 3rd digit is Hex F, then proceed to step (4).
- (3) The MS shall compare using all 3 digits of the SIM-MNC with the BCCH-MNC. If the values match, then the HPLMN match succeeds, otherwise the HPLMN match fails.
- (4) The MS shall compare using just the 1st 2 digits the SIM-MNC with the BCCH-MNC. If the values match, then the HPLMN match succeeds, otherwise the HPLMN match fails.

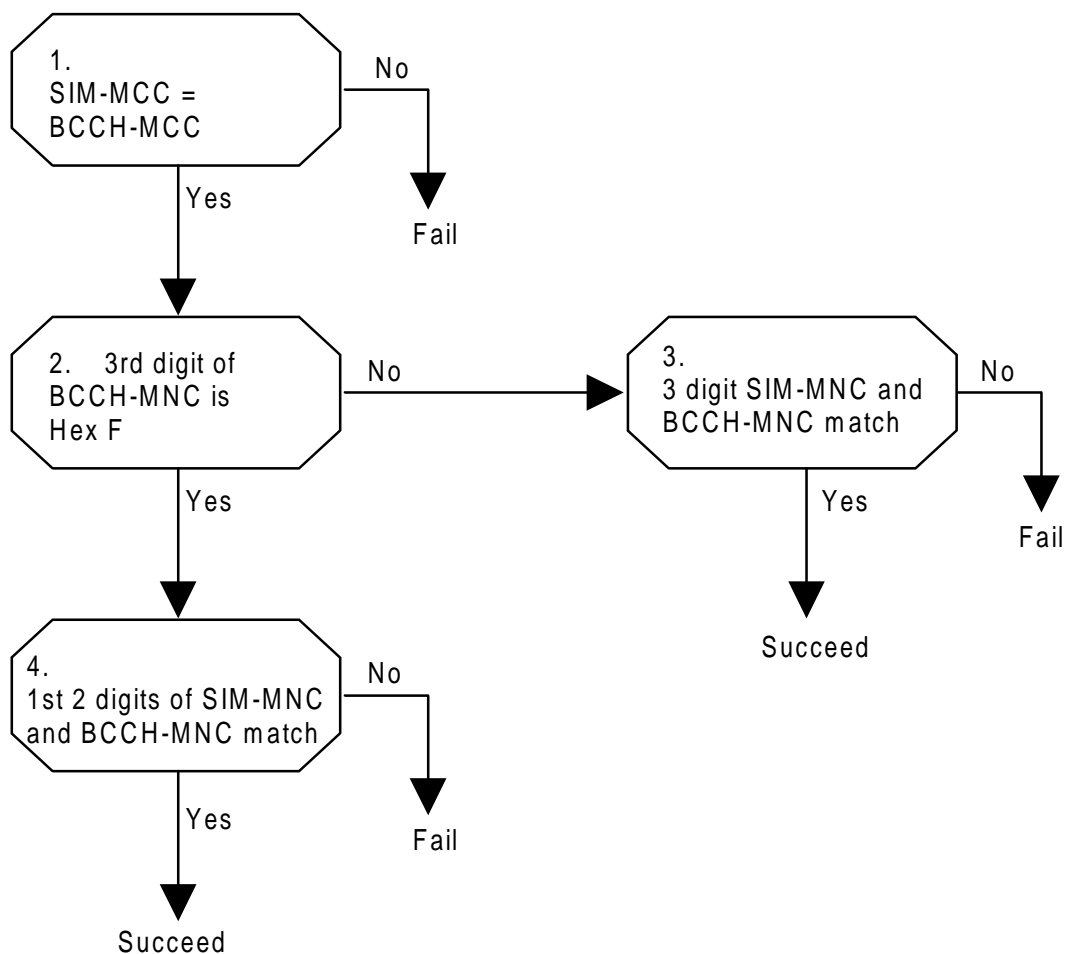

Figure A.1: HPLMN Matching Criteria Logic Flow for mobiles which support GSM and DCS1800 (informative)

HPLMN Matching Criteria for mobiles which support PCS1900 for NA:

Figure A.2 illustrates the logic flow described below. The text below is normative. The Figure A.2 is informative.

- (1) The MS shall compare using all 3 digits the SIM-MCC with the BCCH-MCC. If the values do not match, then the HPLMN match fails.
- (2) The MS shall read the 3rd digit of the BCCH-MNC. If the 3rd digit is Hex F, then proceed to step (4).
- (3) The MS shall compare using all 3 digits the SIM-MNC with the BCCH-MNC. If the values match, then the HPLMN match succeeds, otherwise the HPLMN match fails.

NOTE: These rules (1) – (3) are the same as for mobiles which don't support PCS1900 for NA, except step (4) is different.

- (4) The MS shall determine if the BCCH-MCC lies in the range 310-316 (i.e., whether this network is a PCS1900 for NA network). If the BCCH-MCC lies outside the range 310-316, then proceed to step (6).

- (5) The MS shall compare the 3rd digit of the SIM-MNC with '0'. If the 3rd digit is not '0' then the HPLMN match fails.

NOTE: This is the '0' suffix rule.

- (6) The MS shall compare using just the 1st 2 digits of the SIM-MNC with the BCCH-MNC. If the values match, then the HPLMN match succeeds, otherwise the HPLMN match fails.

NOTE: When PCS1900 for NA switches over to broadcasting 3 digit MNCs in **all** networks, then the additional requirements for PCS1900 for NA can be deleted.

Guidance for Networks in PCS1900 for NA

There may be some problems in the transition period from broadcasting 2 MNC digits to broadcasting 3 MNC digits. Here are some guidelines to avoid these problems.

- (1) Existing network codes. Operators who currently use a 2 digit BCCH-MNC **xy** should use the new code **xy0**.
- (2) New operators allocated 3 digit MNC codes with the same 1st 2 digits as an existing operator shall not use a 3rd digit of 0.

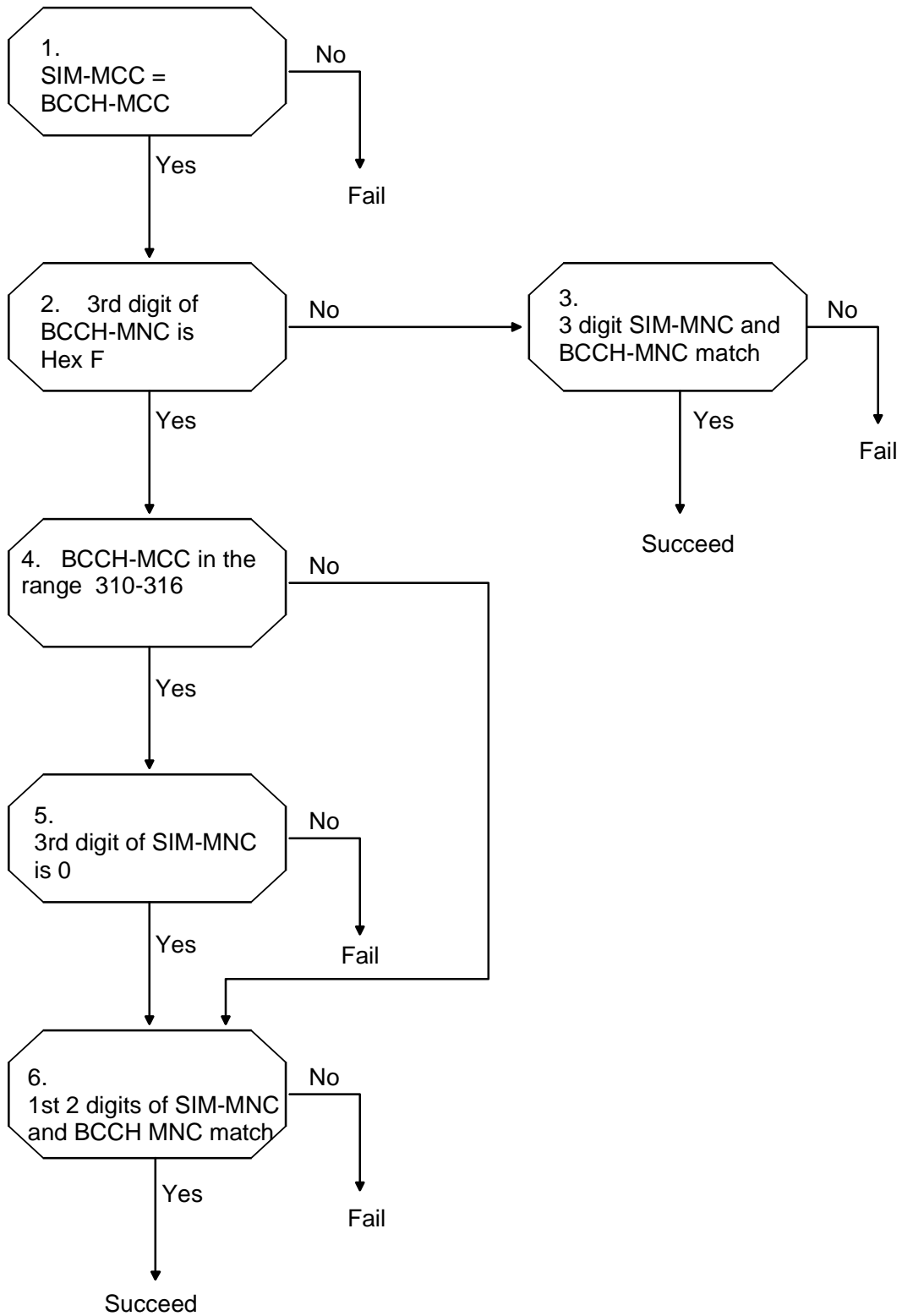

Figure A.2: HPLMN Matching Criteria Logic Flow for mobiles which support PCS1900 for NA (informative)

Annex B (informative): Change history

| SMG# | SPEC | PHASE | VERS | NEW_VERS | CR | SUBJECT |
|------|-------|-------|-------|----------|--------|--|
| s28 | 03.22 | R98 | 6.0.1 | 7.0.0 | A024r1 | HPLMN Determination with 2 or 3 digit MNC |
| s28 | 03.22 | R98 | 6.0.1 | 7.0.0 | A025r1 | Addition of CTS features |
| s28 | 03.22 | R98 | 6.0.1 | 7.0.0 | A027r2 | GSM/PCS Harmonization inclusion of PCS 1900 for NA. |
| s29 | 03.22 | R98 | 6.1.0 | 6.2.0 | A034r3 | EFIMSI changes via Data Download or SIM Toolkit applications |
| s29 | 03.22 | R98 | 7.0.0 | 7.1.0 | A032r6 | Addition of SoLSA functionality |
| S30 | 03.22 | R98 | 7.1.0 | 7.2.0 | A040 | Clarification of SoLSA exclusive cells |
| S30 | 03.22 | R98 | 7.1.0 | 7.2.0 | A044r1 | Clarification of SoLSA exclusive cells |
| CN#6 | 03.22 | R98 | 7.2.0 | 7.3.0 | A039r1 | Correction of Figure A.2 in Annex A |

| Change history | | | | | | | |
|----------------|---------|-----------|------|-----|---------------------------------------|-------|-------|
| Date | TSG CN# | TSG Doc. | CR | Rev | Subject/Comment | Old | New |
| 2001-04 | 11 | NP-010147 | A053 | 2 | Roaming restrictions for GPRS service | 7.3.0 | 7.4.0 |
| | | | | | | | |
| | | | | | | | |
| | | | | | | | |
| | | | | | | | |

History

| Document history | | |
|-------------------------|---------------|-------------|
| V7.1.0 | July 1999 | Publication |
| V7.2.0 | November 1999 | Publication |
| V7.3.0 | December 1999 | Publication |
| V7.4.0 | April 2001 | Publication |
| | | |