

# ETSI TS 100 392-2 V2.4.1 (2003-10)

---

*Technical Specification*

## **Terrestrial Trunked Radio (TETRA); Voice plus Data (V+D); Part 2: Air Interface (AI)**

---



---

Reference

RTS/TETRA-03105

---

Keywords

radio, TETRA, V+D

**ETSI**

650 Route des Lucioles  
F-06921 Sophia Antipolis Cedex - FRANCE

Tel.: +33 4 92 94 42 00 Fax: +33 4 93 65 47 16

Siret N° 348 623 562 00017 - NAF 742 C  
Association à but non lucratif enregistrée à la  
Sous-Préfecture de Grasse (06) N° 7803/88

---

**Important notice**

Individual copies of the present document can be downloaded from:

<http://www.etsi.org>

The present document may be made available in more than one electronic version or in print. In any case of existing or perceived difference in contents between such versions, the reference version is the Portable Document Format (PDF). In case of dispute, the reference shall be the printing on ETSI printers of the PDF version kept on a specific network drive within ETSI Secretariat.

Users of the present document should be aware that the document may be subject to revision or change of status. Information on the current status of this and other ETSI documents is available at

<http://portal.etsi.org/tb/status/status.asp>

If you find errors in the present document, send your comment to:

[editor@etsi.org](mailto:editor@etsi.org)

---

**Copyright Notification**

No part may be reproduced except as authorized by written permission.  
The copyright and the foregoing restriction extend to reproduction in all media.

© European Telecommunications Standards Institute 2003.  
All rights reserved.

**DECT™**, **PLUGTESTS™** and **UMTS™** are Trade Marks of ETSI registered for the benefit of its Members.  
**TIPHON™** and the **TIPHON logo** are Trade Marks currently being registered by ETSI for the benefit of its Members.  
**3GPP™** is a Trade Mark of ETSI registered for the benefit of its Members and of the 3GPP Organizational Partners.

# Contents

Intellectual Property Rights .....	29
Foreword.....	29
1 Scope .....	30
2 References .....	31
3 Definitions and abbreviations.....	33
3.1 Definitions .....	33
3.2 Abbreviations .....	38
4 Radio aspects.....	41
4.1 Introduction .....	41
4.2 Set of logical channels.....	41
4.3 Reference configuration .....	41
4.4 Error control schemes.....	41
4.5 Multiple access and time slot structure.....	42
4.5.1 Hyperframes, multiframe and frames.....	42
4.5.2 Time slots and bursts .....	42
4.5.3 Mapping of logical channels onto physical channels.....	43
4.6 Coding, interleaving and scrambling.....	43
4.7 Modulation .....	43
4.8 Transmission and reception .....	43
4.9 Other radio-related functions.....	43
4.10 Performance .....	44
4.11 TETRA modes of operation .....	44
4.11.1 Transmission modes .....	44
4.11.1.1 D-CT mode .....	44
4.11.1.2 D-CTT mode.....	44
4.11.1.3 D-MCCTT mode.....	44
4.11.1.4 U-MST mode .....	45
4.11.2 Control modes.....	45
4.11.2.1 NCM .....	45
4.11.2.2 MC mode .....	45
5 Modulation .....	45
5.1 Introduction .....	45
5.2 Modulation type .....	45
5.3 Modulation rate .....	45
5.4 Modulation symbol definition.....	45
5.5 Modulated signal definition.....	46
5.6 Modulation filter definition .....	47
5.7 Modulation block diagram .....	47
6 Radio transmission and reception.....	47
6.1 Introduction .....	47
6.2 Frequency bands and channel arrangement.....	47
6.3 Reference test planes .....	48
6.4 Transmitter characteristics.....	48
6.4.1 Output power .....	48
6.4.1.1 Base Station (BS).....	49
6.4.1.2 Mobile Station (MS) .....	49
6.4.2 Unwanted conducted emissions .....	49
6.4.2.1 Definitions.....	49
6.4.2.2 Unwanted emissions close to the carrier .....	50
6.4.2.2.1 Emission during the useful part of the burst .....	50
6.4.2.2.2 Emission during the switching transients .....	51
6.4.2.3 Unwanted emissions far from the carrier .....	51
6.4.2.4 Unwanted emissions during the CLCH and BLCH .....	52

6.4.2.5	Unwanted emissions in the non-transmit state .....	52
6.4.3	Unwanted radiated emissions .....	52
6.4.4	RF tolerance.....	52
6.4.5	RF Output power time mask .....	52
6.4.5.1	BS.....	53
6.4.5.2	MS.....	53
6.4.6	Transmitter intermodulation attenuation.....	53
6.4.6.1	Definition .....	53
6.4.6.2	BS.....	54
6.4.6.3	MS.....	54
6.4.7	Intra-BS intermodulation requirements .....	54
6.5	Receiver characteristics .....	54
6.5.1	Blocking characteristics .....	54
6.5.1.1	Definition .....	54
6.5.1.2	Specification.....	55
6.5.2	Spurious response rejection .....	55
6.5.2.1	Definition .....	55
6.5.2.2	Specification.....	55
6.5.3	Intermodulation response rejection.....	56
6.5.3.1	Definition .....	56
6.5.3.2	Specification.....	56
6.5.4	Unwanted conducted emissions .....	56
6.5.4.1	Definition .....	56
6.5.4.2	Specification.....	56
6.5.5	Unwanted radiated emissions .....	56
6.6	Transmitter/receiver performance .....	56
6.6.1	Modulation accuracy.....	57
6.6.1.1	Ideal case.....	57
6.6.1.2	Vector error magnitude requirement at symbol time .....	57
6.6.2	Receiver performance .....	58
6.6.2.1	Nominal error rates .....	58
6.6.2.2	Dynamic reference sensitivity performance.....	59
6.6.2.2.1	BS receiver performance .....	59
6.6.2.2.2	MS receiver performance .....	59
6.6.2.3	Receiver performance at reference interference ratios .....	60
6.6.2.3.1	BS receiver performance .....	60
6.6.2.3.2	MS receiver performance .....	61
6.6.2.4	Static reference sensitivity performance .....	61
6.6.2.4.1	BS receiver performance .....	61
6.6.2.4.2	MS receiver performance .....	62
6.6.2.5	MS receiver performance for synchronization burst acquisition.....	62
6.6.3	Propagation conditions .....	62
6.6.3.1	Propagation conditions - introduction .....	62
6.6.3.2	Tap-gain process types.....	63
6.6.3.3	Propagation models.....	63
7	Radio sub-system synchronization .....	64
7.1	Introduction .....	64
7.2	General description of synchronization system.....	64
7.3	Timebase counters .....	65
7.3.1	Timing counters .....	65
7.3.2	Values of the counters.....	65
7.4	Timing of transmitted signals.....	65
7.5	BS requirements for synchronization .....	66
7.6	MS requirements for synchronization .....	66
8	Channel coding and scrambling .....	66
8.1	Introduction .....	66
8.2	General .....	67
8.2.1	Interfaces in the error control structure.....	67
8.2.2	Notation .....	68
8.2.3	Definition of error control codes.....	68

8.2.3.1	16-state Rate-Compatible Punctured Convolutional (RCPC) codes .....	68
8.2.3.1.1	Encoding by the 16-state mother code of rate $\frac{1}{4}$ .....	68
8.2.3.1.2	Puncturing of the mother code.....	69
8.2.3.1.3	Puncturing scheme of the RCPC code of rate $\frac{2}{3}$ .....	69
8.2.3.1.4	Puncturing scheme of the RCPC code of rate $\frac{1}{3}$ .....	69
8.2.3.1.5	Puncturing scheme of the RCPC code of rate $\frac{292}{432}$ .....	69
8.2.3.1.6	Puncturing scheme of the RCPC code of rate $\frac{148}{432}$ .....	69
8.2.3.2	Shortened (30,14) Reed-Muller (RM) code .....	70
8.2.3.3	$(K_I + 16, K_I)$ block code .....	70
8.2.4	Definition of interleaving schemes .....	71
8.2.4.1	Block interleaving .....	71
8.2.4.2	Interleaving over $N$ blocks .....	71
8.2.5	Definition of scrambling .....	71
8.2.5.1	Scrambling method .....	71
8.2.5.2	Scrambling sequence.....	71
8.3	Error control schemes.....	72
8.3.1	Access Assignment Channel (AACH).....	73
8.3.2	Broadcast Synchronization Channel (BSCH) .....	73
8.3.3	Traffic channels in circuit switched mode .....	74
8.3.3.1	Traffic CHannel, net rate = 4,8 kbit/s (TCH/4,8).....	74
8.3.3.2	Traffic CHannel, net rate = 2,4 kbit/s (TCH/2,4).....	75
8.3.3.3	Traffic CHannel, net rate = 7,2 kbit/s (TCH/7,2).....	75
8.3.3.4	Speech Traffic Channel, full slot (TCH/S).....	76
8.3.3.5	Speech Traffic Channel, half slot (TCH/S) .....	76
8.3.4	Signalling channels for signalling and packet mode data .....	76
8.3.4.1	Signalling CHannel for mapping onto Half-bursts on the Downlink (SCH/HD), Broadcast Network CHannel (BNCH), and STealing CHannel (STCH).....	76
8.3.4.2	Signalling CHannel for mapping onto Half-bursts on the Uplink (SCH/HU).....	77
8.3.4.3	Signalling CHannel for mapping onto Full bursts (SCH/F) .....	77
9	Channel multiplexing for V+D.....	78
9.1	Introduction .....	78
9.2	Logical channels.....	78
9.2.1	Logical channels hierarchy .....	78
9.2.2	Traffic channels .....	78
9.2.3	Control CHannels (CCH).....	78
9.2.3.1	General .....	78
9.2.3.2	BCCH.....	79
9.2.3.3	LCH.....	79
9.2.3.4	SCH.....	79
9.2.3.5	AACH .....	79
9.2.3.6	STCH .....	79
9.3	The physical resource .....	80
9.3.1	General.....	80
9.3.2	RF channels .....	80
9.3.3	Timeslots .....	81
9.3.4	TDMA frame .....	81
9.3.5	Timeslot numbering .....	81
9.3.6	Subslot .....	81
9.3.7	Multiframe .....	81
9.3.8	Hyperframe .....	81
9.3.9	Frame alignment .....	81
9.4	Physical channels .....	81
9.4.1	General.....	81
9.4.2	Types of physical channels .....	82
9.4.2.1	CP channel .....	82
9.4.2.2	TP channel.....	82
9.4.2.3	UP channel .....	82
9.4.3	Bursts .....	82
9.4.3.1	General .....	82
9.4.3.2	Modulation symbol numbering .....	82
9.4.3.3	Modulation bit numbering.....	83

9.4.3.4	Burst timing.....	83
9.4.4	Type of bursts .....	83
9.4.4.1	General .....	83
9.4.4.2	Modulation bits allocation.....	85
9.4.4.2.1	Control uplink Burst (CB).....	85
9.4.4.2.2	Linearization uplink Burst (LB).....	85
9.4.4.2.3	Linearization downlink burst.....	85
9.4.4.2.4	Normal Uplink Burst (NUB).....	86
9.4.4.2.5	Normal continuous downlink burst .....	86
9.4.4.2.6	Synchronization continuous downlink burst.....	86
9.4.4.2.7	Normal discontinuous downlink burst.....	86
9.4.4.2.8	Synchronization discontinuous downlink burst.....	87
9.4.4.3	Burst fields .....	87
9.4.4.3.1	Frequency correction field.....	87
9.4.4.3.2	Normal training sequence.....	88
9.4.4.3.3	Extended training sequence.....	88
9.4.4.3.4	Synchronization training sequence.....	88
9.4.4.3.5	Tail bits.....	88
9.4.4.3.6	Phase adjustment bits .....	89
9.4.5	Transmission modes .....	89
9.4.5.1	BS continuous transmission .....	89
9.4.5.2	BS timesharing transmission.....	90
9.4.5.3	MS multiple slot transmission.....	90
9.5	Mapping of logical channels into physical channels .....	91
9.5.1	General mapping of logical channels.....	91
9.5.2	Mapping of BCCH and CLCH .....	92
9.5.3	Mapping of SCH.....	93
9.5.4	Mapping of TCH and STCH.....	93
9.5.5	Mapping of AACH .....	93
9.6	Monitoring pattern for transmitting MSs.....	93
9.7	BS timesharing transmission .....	94
9.7.1	Carrier sharing .....	94
9.7.2	MCCH sharing.....	94
9.8	Modes of control .....	94
9.8.1	NCM.....	94
9.8.2	MCM .....	95
10	Radio subsystem link control .....	95
10.1	Introduction .....	95
10.2	RF power control.....	96
10.3	Radio link measurements .....	96
10.3.1	Received signal strength .....	96
10.3.1.1	Sample duration for signal strength measurement .....	96
10.3.2	Signal quality .....	96
10.3.3	Round-trip MS-BS path delay .....	96
11	Call Control (CC) service description .....	96
11.1	Introduction .....	96
11.2	Services offered.....	96
11.3	CC service .....	97
11.3.1	CC primitives exchanged through the TNCC-SAP .....	97
11.3.2	Service primitives at the TNCC-SAP .....	97
11.3.3	Primitive description.....	98
11.3.3.1	TNCC-ALERT primitive .....	98
11.3.3.2	TNCC-COMplete primitive .....	99
11.3.3.3	TNCC-DTMF primitive .....	99
11.3.3.4	TNCC-MODIFY primitive .....	100
11.3.3.5	TNCC-NOTIFY primitive .....	100
11.3.3.6	TNCC-PROCEED primitive.....	101
11.3.3.7	TNCC-RELEASE primitive.....	101
11.3.3.8	TNCC-SETUP primitive .....	101
11.3.3.9	TNCC-TX primitive.....	102

11.3.4	Parameter description .....	103
11.4	States for CC SAP .....	110
12	Supplementary Service (SS) service description.....	110
12.1	Introduction .....	110
12.2	Services offered.....	111
12.3	SS service .....	111
12.3.1	Primitives exchanged through TNSS-SAP .....	111
12.3.2	Parameter description .....	111
13	Short Data Service (SDS) service description.....	112
13.1	Introduction .....	112
13.2	Services offered.....	112
13.3	SDS .....	112
13.3.1	SDS primitives exchanged through the TNSDS-SAP .....	112
13.3.2	Service primitives at the TNSDS-SAP .....	113
13.3.2.1	TNSDS-STATUS primitive .....	113
13.3.2.2	TNSDS-REPORT primitive.....	114
13.3.2.3	TNSDS-UNITDATA primitive.....	114
13.3.2.4	TNSDS-CANCEL primitive .....	115
13.3.3	Parameter description .....	115
13.3.4	State description.....	117
13.3.4.1	NULL state.....	117
13.3.4.2	SHORT DATA INITIATED state .....	117
13.3.5	Service state diagram for the TNSDS-SAP .....	118
14	CMCE protocol .....	118
14.1	Introduction .....	118
14.2	Overview of CMCE.....	118
14.2.1	Communication routes of the CMCE model.....	119
14.2.2	Protocol structure and protocol stack.....	120
14.2.3	Addressing rules .....	122
14.2.4	CC, SS and SDS sub-entities .....	122
14.2.4.1	CC sub-entity .....	122
14.2.4.2	SS sub-entity .....	123
14.2.4.3	SDS sub-entity .....	123
14.2.5	PC sub-entity .....	123
14.2.6	Internal routes .....	124
14.2.7	Intra-CMCE primitive summary.....	126
14.2.7.1	Down link CC PDU parameters .....	126
14.2.7.2	Uplink CC PDU parameters.....	126
14.2.7.3	Downlink SS PDU parameters.....	127
14.2.7.4	Uplink SS PDU parameters.....	127
14.2.7.5	Down link SDS PDU parameters .....	127
14.2.7.6	Uplink SDS PDU parameters.....	127
14.2.7.7	CMCE management primitives.....	127
14.2.7.7.0	ACTIVITY request.....	127
14.2.7.7.1	BREAK indication.....	127
14.2.7.7.1a	BUSY indication .....	127
14.2.7.7.2	CANCEL request.....	128
14.2.7.7.3	CLOSE indication .....	128
14.2.7.7.4	CONFIGURE indication .....	128
14.2.7.7.5	CONFIGURE request.....	128
14.2.7.7.6	IDENTITIES request.....	128
14.2.7.7.6a	IDLE indication .....	128
14.2.7.7.6b	INFO indication.....	129
14.2.7.7.7	OPEN indication.....	129
14.2.7.7.8	REOPEN indication.....	129
14.2.7.7.9	REPORT indication.....	129
14.2.7.7.10	RESUME indication .....	129
14.3	Overview of services required by the CMCE.....	129
14.4	CMCE protocol states .....	129
14.4.1	States for PC .....	130

14.4.1.1	CLOSED .....	130
14.4.1.2	OPEN .....	130
14.4.2	States for CC .....	131
14.4.2.1	IDLE .....	133
14.4.2.2	MO-CALL-SETUP .....	133
14.4.2.3	MT-CALL-SETUP .....	133
14.4.2.4	CALL ACTIVE .....	134
14.4.2.5	CALL DISCONNECT .....	134
14.4.2.6	WAIT .....	134
14.4.3	States for SS .....	134
14.4.4	States for SDS .....	135
14.5	Procedures .....	135
14.5.1	Individual CC procedures .....	135
14.5.1.1	Call set-up procedures .....	136
14.5.1.1.1	Incoming call .....	137
14.5.1.1.2	Outgoing call .....	138
14.5.1.1.3	Colliding calls .....	139
14.5.1.1.4	Unsuccessful call set-up .....	140
14.5.1.1.5	Call rejection .....	140
14.5.1.2	Call maintenance procedures .....	140
14.5.1.2.1	Transmission control procedures .....	141
14.5.1.2.2	Call status information procedures .....	145
14.5.1.2.3	Call modification procedures .....	146
14.5.1.2.4	Call restoration procedures .....	147
14.5.1.2.5	DTMF procedures .....	149
14.5.1.2.6	Calls to and from external subscribers .....	150
14.5.1.3	Call disconnection procedures .....	151
14.5.1.3.1	User initiated disconnection .....	151
14.5.1.3.2	Network initiated disconnection .....	152
14.5.1.3.3	Reception of disconnection request .....	152
14.5.1.3.4	Expiry of timers .....	152
14.5.1.3.5	Colliding disconnection .....	153
14.5.1.4	U-Plane switching .....	153
14.5.1.4.1	End of call set-up phase .....	154
14.5.1.4.2	During call maintenance phase .....	154
14.5.1.4.3	Call disconnection phase .....	155
14.5.2	Group CC procedures .....	155
14.5.2.1	Call set-up procedures .....	155
14.5.2.1.1	Incoming call .....	156
14.5.2.1.2	Outgoing call .....	157
14.5.2.1.3	Colliding calls .....	158
14.5.2.1.4	Unsuccessful call set-up .....	158
14.5.2.1.5	Call rejection .....	158
14.5.2.2	Call maintenance procedures .....	159
14.5.2.2.1	Transmission control procedures .....	159
14.5.2.2.2	Call status information procedures .....	163
14.5.2.2.3	Call modification procedures .....	164
14.5.2.2.4	Call restoration procedures .....	165
14.5.2.2.5	DTMF procedures .....	167
14.5.2.2.6	Temporary address handling procedures .....	167
14.5.2.2.7	Calls to and from external subscribers .....	168
14.5.2.3	Call disconnection procedures .....	168
14.5.2.3.1	User initiated disconnection .....	169
14.5.2.3.2	Network initiated disconnection .....	169
14.5.2.3.3	Reception of disconnection request .....	170
14.5.2.3.4	Colliding disconnection .....	170
14.5.2.3.5	Expiry of timers .....	170
14.5.2.4	U-Plane switching .....	171
14.5.2.4.1	End of call set-up phase .....	171
14.5.2.4.2	During call maintenance phase .....	171
14.5.2.4.3	Call disconnection phase .....	172
14.5.2.5	Void .....	172



14.5.2.6	Acknowledged group call procedures .....	172
14.5.2.7	Call ownership .....	173
14.5.3	Traffic channel assignment procedures.....	174
14.5.3.1	SwMI related procedures .....	174
14.5.3.2	MS related procedures.....	175
14.5.3.2.1	General procedures .....	175
14.5.3.2.2	Procedures for acceptance of individually-addressed channel allocation.....	176
14.5.3.2.3	Procedures for acceptance of group-addressed channel allocation.....	176
14.5.4	SS procedures .....	178
14.5.5	SDS procedures .....	178
14.5.5.1	Incoming short data message .....	178
14.5.5.2	Outgoing short data messages .....	178
14.5.6	PC procedures.....	179
14.5.6.1	Access to the communication resources.....	179
14.5.6.2	Access priority handling .....	179
14.5.6.2.1	Cancel.....	180
14.5.6.3	CMCE PDU exchange .....	180
14.5.6.3.1	Choice of layer 2 service .....	180
14.5.6.4	Control information exchange.....	180
14.5.6.5	PC protocol error conditions .....	181
14.5.6.5.1	PDU type error .....	181
14.5.6.5.2	Invalid call identifier .....	181
14.5.6.5.3	MS busy.....	181
14.5.7	Subscriber class .....	181
14.5.8	Activity handling .....	181
14.6	Protocol timers .....	182
14.7	PDU descriptions.....	183
14.7.1	PDU description tables - downlink .....	183
14.7.1.1	D-ALERT.....	183
14.7.1.2	D-CALL PROCEEDING.....	184
14.7.1.3	D-CALL RESTORE .....	184
14.7.1.4	D-CONNECT.....	185
14.7.1.5	D-CONNECT ACKNOWLEDGE.....	185
14.7.1.6	D-DISCONNECT .....	186
14.7.1.7	D-FACILITY .....	186
14.7.1.8	D-INFO .....	186
14.7.1.9	D-RELEASE.....	187
14.7.1.10	D-SDS-DATA.....	187
14.7.1.11	D-STATUS .....	188
14.7.1.12	D-SETUP .....	188
14.7.1.13	D-TX CEASED.....	189
14.7.1.14	D-TX CONTINUE.....	189
14.7.1.15	D-TX GRANTED .....	190
14.7.1.16	D-TX INTERRUPT .....	190
14.7.1.17	D-TX WAIT.....	191
14.7.2	PDU description tables - uplink .....	191
14.7.2.1	U-ALERT.....	191
14.7.2.2	U-CALL RESTORE .....	192
14.7.2.3	U-CONNECT.....	192
14.7.2.4	U-DISCONNECT .....	193
14.7.2.5	U-FACILITY .....	193
14.7.2.6	U-INFO .....	193
14.7.2.7	U-STATUS .....	194
14.7.2.8	U-SDS-DATA.....	194
14.7.2.9	U-RELEASE.....	195
14.7.2.10	U-SETUP .....	196
14.7.2.11	U-TX CEASED.....	196
14.7.2.12	U-TX DEMAND.....	197
14.7.3	PDU description tables - downlink and uplink .....	197
14.7.3.1	General rules for function not supported.....	197
14.7.3.2	CMCE FUNCTION NOT SUPPORTED .....	197
14.8	Information elements coding .....	198

14.8.1	Area Selection.....	198
14.8.2	Basic service information .....	199
14.8.3	Call identifier .....	199
14.8.3a	Call identifier present.....	199
14.8.4	Call ownership .....	199
14.8.5	Called party type identifier .....	200
14.8.6	Called party SNA.....	200
14.8.7	Called party extension .....	200
14.8.8	Called party SSI.....	200
14.8.9	Calling party type identifier.....	200
14.8.10	Calling party extension .....	201
14.8.11	Calling party SSI.....	201
14.8.12	Call priority.....	201
14.8.13	Call status .....	202
14.8.14	Call queued .....	202
14.8.15	Continue.....	202
14.8.16	Call time-out .....	203
14.8.17	Call time-out, set-up phase .....	203
14.8.17a	Circuit mode type .....	204
14.8.17b	CLIR control.....	204
14.8.17c	Communication type.....	204
14.8.18	Disconnect cause .....	205
14.8.18a	DM-MS address.....	205
14.8.19	DTMF .....	205
14.8.19a	DTMF digit.....	206
14.8.19b	DTMF type .....	206
14.8.20	External subscriber number .....	207
14.8.21	Encryption control .....	207
14.8.21a	Encryption flag .....	207
14.8.22	Facility .....	208
14.8.23	Hook method selection .....	208
14.8.24	Length indicator.....	208
14.8.25	New call identifier .....	208
14.8.26	Modify .....	208
14.8.27	Notification indicator.....	209
14.8.27a	Other party type identifier.....	209
14.8.27b	Other party SNA.....	209
14.8.27c	Other party extension.....	209
14.8.27d	Other party SSI .....	209
14.8.28	PDU type .....	210
14.8.29	Poll request .....	210
14.8.30	Poll response.....	210
14.8.31	Poll response addresses.....	211
14.8.32	Poll response number.....	211
14.8.33	Poll response percentage.....	211
14.8.34	Pre-coded status .....	212
14.8.35	Proprietary .....	212
14.8.36	Request to transmit/send data .....	212
14.8.37	Reset call time-out timer (T310).....	212
14.8.38	Short data type identifier.....	213
14.8.39	Simplex/duplex selection.....	213
14.8.39a	Slots per frame.....	213
14.8.40	Speech service .....	213
14.8.41	Temporary address.....	213
14.8.42	Transmission grant.....	214
14.8.43	Transmission request permission.....	214
14.8.44	Transmitting party type identifier .....	214
14.8.45	Transmitting party extension .....	214
14.8.46	Transmitting party SSI.....	215
14.8.47	TX demand priority .....	215
14.8.48	Type 3 element identifier.....	215
14.8.49	User defined data-1 .....	215

14.8.50	User defined data-2 .....	216
14.8.51	User defined data-3 .....	216
14.8.52	User defined data-4 .....	216
15	Mobility Management (MM) service description .....	216
15.1	Introduction .....	216
15.2	Services offered .....	216
15.3	Primitive description .....	217
15.3.1	Service state model for the MS .....	217
15.3.2	Service primitives at the TNMM-SAP, MS/LS side .....	218
15.3.3	Primitive description .....	218
15.3.3.1	TNMM-ATTACH DETACH GROUP IDENTITY primitive .....	218
15.3.3.2	TNMM-DEREGISTRATION primitive .....	219
15.3.3.3	TNMM-DISABLING primitive .....	219
15.3.3.4	TNMM-ENABLING primitive .....	219
15.3.3.5	TNMM-ENERGY SAVING primitive .....	219
15.3.3.6	TNMM-REPORT primitive .....	220
15.3.3.7	TNMM-REGISTRATION primitive .....	220
15.3.3.8	TNMM-SERVICE primitive .....	221
15.3.3.9	TNMM-STATUS primitive .....	221
15.3.4	Parameters description .....	221
15.3.5	State description for the MS .....	225
15.3.5.1	Not updated .....	225
15.3.5.2	Wait updating .....	225
15.3.5.3	Updated .....	225
15.3.5.4	Temporary disabled .....	225
15.3.5.5	Permanently disabled .....	225
15.3.6	Service state diagram for the TNMM-SAP .....	226
16	MM protocol .....	229
16.1	Introduction .....	229
16.2	MM procedures .....	230
16.2.1	General .....	230
16.2.2	Services provided by the protocol .....	230
16.2.3	Underlying services assumed by the protocol .....	231
16.2.4	Services assumed from the local environment .....	231
16.3	Protocol functions .....	231
16.3.1	Activation and control of underlying MLE Service .....	233
16.3.1.1	Activation procedure .....	233
16.3.1.2	Deactivation procedure .....	233
16.3.1.3	Maintenance procedures .....	234
16.3.1.3.1	Report and cancel handling .....	234
16.3.1.3.2	Stealing permission and stealing repeats flag handling .....	234
16.3.1.3.3	Busy handling .....	234
16.3.1.3.4	Activity handling .....	234
16.4	Registration procedure .....	234
16.4.1	MLE initiated registration procedure .....	235
16.4.1.1	Normal registration .....	235
16.4.1.2	Forward registration .....	240
16.4.2	User application initiated registration procedure .....	242
16.4.3	Infrastructure initiated registration procedure .....	246
16.4.4	Colliding registrations .....	248
16.4.5	Expiry of timer T351 .....	248
16.4.6	Expiry of LA timers .....	248
16.4.7	Lifetime of ASSI/(V)ASSI .....	249
16.4.7.1	ASSI/(V)ASSI validity at migration .....	249
16.4.7.2	ASSI/(V)ASSI validity by MS initiative .....	249
16.4.7.3	ASSI/(V)ASSI validity at registration rejection .....	249
16.4.8	Temporary registration .....	249
16.4.9	Subscriber class procedures .....	250
16.4.10	Frequency band capability procedures .....	250
16.4.11	Air to ground reporting procedure .....	251

16.5	Enable and disable procedures .....	251
16.6	De-registration procedure .....	252
16.6.1	Trunking mode de-registration .....	252
16.6.2	Direct mode related de-registration .....	252
16.7	Energy economy .....	253
16.7.1	Energy economy mode procedure .....	253
16.7.2	Procedures for requesting Direct Mode dual watch operation .....	254
16.7.2.1	Introduction .....	254
16.7.2.2	MS requesting to start, modify or resume dual watch mode .....	255
16.7.2.3	MS terminating dual watch mode .....	257
16.7.2.4	SwMI modifying or terminating dual watch mode .....	257
16.7.2.5	Changing between modes .....	258
16.7.2.6	General dual watch procedures .....	258
16.7.2.7	Idle dual watch without informing SwMI .....	259
16.7.3	Expiry of timer T352 .....	259
16.8	Attachment/detachment of group identities and group reporting procedures .....	259
16.8.1	Infrastructure initiated attachment/detachment of group identities procedure .....	260
16.8.2	MS initiated attachment/detachment of group identities procedure .....	261
16.8.3	SwMI initiated group report procedure .....	262
16.8.4	MS initiated group report procedure .....	263
16.8.5	Expiry of timer T353 .....	264
16.8.6	Colliding requests for group attachment/detachment and group reporting .....	264
16.8.7	Group Identity Address Type (GIAT) usage in group identity downlink/uplink .....	265
16.8.8	PDU or function not supported .....	266
16.9	MM PDU structures and contents .....	266
16.9.1	MM PDU general description .....	266
16.9.2	MM PDU description tables - downlink .....	266
16.9.2.1	D-ATTACH/DETACH GROUP IDENTITY .....	266
16.9.2.2	D-ATTACH/DETACH GROUP IDENTITY ACKNOWLEDGEMENT .....	267
16.9.2.3	D-DISABLE (Void) .....	267
16.9.2.4	D-ENABLE (Void) .....	267
16.9.2.5	D-MM STATUS .....	267
16.9.2.5.1	D-MM STATUS generic structure .....	267
16.9.2.5.2	D-CHANGE OF ENERGY SAVING MODE REQUEST .....	268
16.9.2.5.3	D-CHANGE OF ENERGY SAVING MODE RESPONSE .....	268
16.9.2.5.4	D-DUAL WATCH MODE RESPONSE .....	269
16.9.2.5.5	D-TERMINATING DUAL WATCH MODE RESPONSE .....	269
16.9.2.5.6	D-CHANGE OF DUAL WATCH MODE REQUEST .....	270
16.9.2.5.7	Direct mode gateway related D-MM STATUS .....	270
16.9.2.5.8	D-MS FREQUENCY BANDS REQUEST .....	270
16.9.2.5.9	DISTANCE REPORTING REQUEST .....	271
16.9.2.6	D-STATUS (Void) .....	271
16.9.2.7	D-LOCATION UPDATE ACCEPT .....	271
16.9.2.8	D-LOCATION UPDATE COMMAND .....	272
16.9.2.9	D-LOCATION UPDATE REJECT .....	272
16.9.2.10	D-LOCATION UPDATE PROCEEDING .....	272
16.9.3	MM PDU descriptions - uplink .....	273
16.9.3.1	U-ATTACH/DETACH GROUP IDENTITY .....	273
16.9.3.2	U-ATTACH/DETACH GROUP IDENTITY ACKNOWLEDGEMENT .....	273
16.9.3.3	U-ITSI DETACH .....	274
16.9.3.4	U-LOCATION UPDATE DEMAND .....	274
16.9.3.5	U-MM STATUS .....	275
16.9.3.5.1	U-MM STATUS generic construction .....	275
16.9.3.5.2	U-CHANGE OF ENERGY SAVING MODE REQUEST .....	275
16.9.3.5.3	U-CHANGE OF ENERGY SAVING MODE RESPONSE .....	276
16.9.3.5.4	U-DUAL WATCH MODE REQUEST .....	276
16.9.3.5.5	U-TERMINATING DUAL WATCH MODE REQUEST .....	277
16.9.3.5.6	U-CHANGE OF DUAL WATCH MODE RESPONSE .....	277
16.9.3.5.7	U-START OF DIRECT MODE OPERATION .....	278
16.9.3.5.8	Direct mode gateway related U-MM STATUS .....	278
16.9.3.5.9	U-MS FREQUENCY BANDS INFORMATION .....	278
16.9.4	PDU description tables - downlink and uplink .....	279

16.9.4.1	MM FUNCTION NOT SUPPORTED .....	279
16.10	MM information elements coding .....	279
16.10.1	Address extension .....	279
16.10.2	Cipher control .....	279
16.10.3	Cipher parameters .....	280
16.10.4	Cipher key type (Void) .....	280
16.10.5	Class of MS .....	280
16.10.6	Class of usage .....	281
16.10.7	Disabling type .....	282
16.10.7a	Default group attachment lifetime .....	282
16.10.7b	Distance reporting timer .....	282
16.10.7c	Distance reporting validity .....	282
16.10.8	Distribution on 18th frame .....	282
16.10.8a	DMO carrier .....	283
16.10.8b	Dual watch mode .....	283
16.10.9	Energy saving mode .....	284
16.10.10	Energy saving information .....	284
16.10.11	Frame Number .....	284
16.10.11a	Frequency band definition .....	285
16.10.12	Group identity accept/reject .....	285
16.10.13	Group identity acknowledgement request .....	285
16.10.14	Group identity acknowledgement type .....	285
16.10.15	Group identity address type .....	286
16.10.16	Group identity attachment lifetime .....	286
16.10.17	Group identity attach/detach mode .....	286
16.10.18	Group identity attach/detach type identifier .....	286
16.10.19	Group identity attachment .....	286
16.10.20	Group identity detachment downlink .....	287
16.10.21	Group identity detachment uplink .....	287
16.10.22	Group identity downlink .....	287
16.10.23	Group identity location accept .....	288
16.10.24	Group identity location demand .....	288
16.10.25	Group identity location demand ack (void) .....	288
16.10.26	Group identity report .....	288
16.10.27	Group identity uplink .....	289
16.10.27a	Group report response .....	289
16.10.28	Group Short Subscriber Identity (GSSI) .....	289
16.10.29	KSG number .....	289
16.10.30	LA .....	290
16.10.31	LACC .....	290
16.10.32	LANC .....	290
16.10.33	LA timer .....	290
16.10.34	LA information .....	291
16.10.34a	Length of the copied PDU .....	291
16.10.35	Location update type .....	291
16.10.35a	Location update accept type .....	292
16.10.36	Mobile Country Code (MCC) .....	292
16.10.37	Mobile Network Code (MNC) .....	292
16.10.37a	Mode change information .....	292
16.10.37b	MS operating with type 2 repeater .....	293
16.10.38	Multiframe Number (MN) .....	293
16.10.38a	Not-supported PDU type .....	293
16.10.38b	Number of frequency band definitions .....	293
16.10.39	PDU type .....	294
16.10.40	New registered area .....	294
16.10.41	Proprietary .....	294
16.10.41a	Reason for dual watch change by SwMI .....	295
16.10.42	Reject cause .....	295
16.10.43	Request to append LA .....	295
16.10.43a	Re-send interval .....	296
16.10.43b	Result of dual watch request .....	296
16.10.44	SSI .....	296

16.10.45	SCCH information .....	297
16.10.46	SCCH information and distribution on 18th frame .....	297
16.10.47	SCK number .....	297
16.10.47a	Start of direct mode operation cause .....	297
16.10.48	Status downlink .....	298
16.10.48a	Status uplink .....	298
16.10.49	Subscriber class .....	299
16.10.50	TEI (void) .....	299
16.10.51	Type 3/4 element identifier .....	299
16.10.52	(V)GSSI .....	299
16.10.53	Zero bit .....	300
16.11	Parameters .....	300
16.11.1	Timers .....	300
16.11.1.1	Timer T351: Registration response time .....	300
16.11.1.2	Timer T352: Energy mode response time .....	300
16.11.1.3	Timer T353: Attach/Detach response time .....	300
17	MLE service description .....	300
17.1	Introduction .....	300
17.2	Summary of services offered by MLE protocol .....	301
17.3	Service descriptions .....	302
17.3.1	Service state diagram for the LMM-SAP .....	302
17.3.2	Service primitives for the LMM-SAP .....	304
17.3.3	Service state diagram for the LCMC-SAP .....	306
17.3.4	Service primitives for LCMC-SAP .....	307
17.3.5	Service state diagram for the LTPD-SAP .....	308
17.3.6	Service primitives for LTPD-SAP .....	310
17.3.7	(Void) .....	311
17.3.8	(Void) .....	312
17.3.9	Parameter summary .....	312
18	MLE protocol .....	317
18.1	Introduction .....	317
18.2	Overview of the sub-layer .....	317
18.2.1	Protocol environment .....	317
18.2.2	Services and primitives offered by the MLE to the MM entity .....	318
18.2.3	Services and primitives offered by the MLE to the CMCE entities .....	319
18.2.4	Services and primitives offered by the MLE to the SNDCP entity .....	320
18.2.5	(Void) .....	321
18.2.6	Services and primitives offered by layer 2 to MLE .....	321
18.2.7	Services and primitives between the MLE and the LLME .....	321
18.2.8	Protocol sequences .....	322
18.3	MLE functions .....	326
18.3.1	Overview .....	326
18.3.2	Access to the communication resources and activation of the MLE .....	327
18.3.3	Deactivation of the MLE .....	327
18.3.4	Attachment management sub-entity .....	327
18.3.4.1	Scanning of cells .....	328
18.3.4.2	Monitoring of neighbour cells .....	328
18.3.4.3	Surveillance of the serving cell .....	329
18.3.4.4	Ranking of neighbour cells .....	329
18.3.4.4.1	Ranking of monitored cells .....	330
18.3.4.4.2	Ranking of scanned cells .....	330
18.3.4.5	Criteria used during cell reselection .....	330
18.3.4.5.1	Criterion for starting the monitoring process .....	330
18.3.4.5.2	Criterion for starting scanning .....	330
18.3.4.5.3	Criterion for radio link failure .....	330
18.3.4.5.4	Criterion for radio relinquishable cell .....	331
18.3.4.5.5	Criterion for radio improvable cell .....	331
18.3.4.5.6	Criterion for radio usable cell .....	331
18.3.4.5.7	Criteria for initiating the cell reselection procedures .....	331
18.3.4.6	Initial cell selection .....	333

18.3.4.7	Cell reselection.....	334
18.3.4.7.1	Determination of which type of reselection to apply.....	336
18.3.4.7.2	Undeclared cell reselection.....	337
18.3.4.7.3	Unannounced cell reselection.....	339
18.3.4.7.4	Announced cell reselection - type 3.....	341
18.3.4.7.5	Announced cell reselection - type 2.....	344
18.3.4.7.6	Announced cell reselection - type 1.....	348
18.3.4.8	Change of broadcast parameters by the SwMI.....	352
18.3.5	Data transfer sub-entity.....	353
18.3.5.1	Address handling.....	353
18.3.5.1.1	Link addressing.....	353
18.3.5.1.2	Link addresses to be placed in layer 2.....	353
18.3.5.1.3	Layer 2 end point identifier.....	354
18.3.5.1.4	Subscriber class.....	354
18.3.5.2	MLE connection handling.....	354
18.3.5.2.1	Data transfer states.....	354
18.3.5.3	Selection of LLC services.....	354
18.3.5.3.1	Selection of LLC services via TLA-SAP.....	354
18.3.5.3.2	Selection of LLC services via TLB-SAP.....	358
18.3.5.3.3	Selection of LLC services via TLC-SAP.....	358
18.3.5.4	Routing of local control information.....	360
18.3.6	Network broadcast sub-entity.....	360
18.3.6.1	Summary.....	360
18.3.6.2	System information.....	361
18.3.6.3	Message formats for system information.....	361
18.3.6.4	Network broadcast procedures.....	361
18.3.6.5	Neighbour cell enquiry procedure.....	361
18.3.7	Management sub-entity.....	362
18.4	PDU descriptions.....	362
18.4.1	Data transfer PDUs at the TLA-SAP.....	362
18.4.1.1	Protocol discriminator.....	362
18.4.1.2	PDU type.....	363
18.4.1.3	MLE service user PDUs.....	363
18.4.1.4	MLE protocol PDUs.....	363
18.4.1.4.1	D-NWRK-BROADCAST.....	363
18.4.1.4.2	D-NEW-CELL.....	364
18.4.1.4.3	D-PREPARE-FAIL.....	364
18.4.1.4.4	D-RESTORE-ACK.....	364
18.4.1.4.5	D-RESTORE-FAIL.....	365
18.4.1.4.6	U-PREPARE.....	365
18.4.1.4.7	U-RESTORE.....	365
18.4.2	Broadcast PDUs at the TLB-SAP.....	366
18.4.2.1	D-MLE-SYNC.....	366
18.4.2.2	D-MLE-SYSINFO.....	366
18.5	Information elements coding.....	367
18.5.1	Cell reselection types supported.....	367
18.5.2	BS service details.....	367
18.5.3	Cell identifier.....	368
18.5.4	Cell re-select parameters.....	368
18.5.5	Cell service level.....	368
18.5.6	Channel command valid.....	369
18.5.7	Fail cause.....	369
18.5.8	Late entry supported.....	369
18.5.9	Location Area (LA).....	369
18.5.10	Main carrier number.....	370
18.5.11	Main carrier number extension.....	370
18.5.12	Minimum Rx access level.....	370
18.5.13	Maximum MS transmit power.....	371
18.5.14	MCC.....	371
18.5.15	MNC.....	371
18.5.16	Neighbour cell broadcast.....	371
18.5.17	Neighbour cell information.....	372

18.5.18	Neighbour cell synchronised.....	372
18.5.19	Number of neighbour cells .....	373
18.5.20	PDU type .....	373
18.5.21	Protocol discriminator.....	373
18.5.22	Subscriber class .....	374
18.5.23	TDMA frame offset .....	374
18.5.24	TETRA network time .....	375
18.5.25	Timeshare cell and AI encryption information .....	375
18.6	Timers .....	376
18.6.1	Timer related actions .....	376
18.6.2	Timer T370 - cell reselection preparation response time .....	376
19	Layer 2 overview .....	376
19.1	Introduction .....	376
19.2	Layer 2 architecture .....	376
19.2.1	Access to the DLL .....	377
19.2.2	Information flow inside the DLL .....	378
19.2.2.1	Basic link .....	379
19.2.2.2	Advanced link .....	380
19.2.2.3	Segmentation and fragmentation.....	380
19.2.3	Sub-layers .....	381
19.2.3.1	LLC sub-layer .....	382
19.2.3.2	MAC sub-layer.....	382
19.2.4	Logical channels .....	383
19.2.4.1	Logical channels at the LLC-SAP.....	383
19.2.4.2	Logical channels at the MAC-SAP .....	383
19.2.4.3	MAC internal logical channels.....	383
19.2.4.4	Logical channels at the lower MAC.....	384
19.2.5	Lower layer management at the DLL .....	386
19.3	System modes of operation .....	386
19.3.1	Normal mode .....	386
19.3.2	Extended mode .....	386
19.3.3	Minimum mode .....	387
19.3.4	Discontinuous transmission mode .....	387
19.3.5	Time sharing mode .....	387
19.3.5.1	Carrier sharing mode.....	387
19.3.5.2	MCCCH sharing mode .....	387
19.4	MS modes of operation .....	387
19.4.1	Idle mode .....	387
19.4.2	Signalling and packet mode .....	387
19.4.2.1	Common control channel .....	387
19.4.2.2	Secondary control channels.....	387
19.4.2.3	Associated Control Channel (ACCH) .....	388
19.4.2.4	Full and half slot signalling.....	388
19.4.3	Traffic mode .....	390
19.4.3.1	Normal operation .....	390
19.4.3.2	Stealing mechanism .....	391
19.4.4	Selection of the mode of operation .....	391
19.4.5	Energy economy mode .....	392
19.4.6	Support of concurrent calls .....	392
19.4.7	Support of air-interface encryption.....	392
19.5	Scenarios for primitives and PDU transfer on the air interface .....	392
20	Layer 2 service description.....	397
20.1	Introduction .....	397
20.2	Layer 2 service description.....	397
20.2.1	LLC SAPs.....	397
20.2.2	MAC SAPs .....	398
20.2.3	Generic primitive types.....	398
20.2.4	Parameters definition for LLC and MAC service primitives.....	398
20.2.4.1	Address type.....	398
20.2.4.2	Advanced link service .....	398



20.2.4.3	Call release .....	398
20.2.4.4	Channel .....	398
20.2.4.5	Channel change accepted .....	399
20.2.4.6	Channel change handle .....	399
20.2.4.7	Channel change response required .....	399
20.2.4.8	CSS endpoint identifier .....	399
20.2.4.9	Distribution on the 18th frame .....	399
20.2.4.10	Dual watch energy economy group .....	399
20.2.4.11	Dual watch startpoint .....	399
20.2.4.12	Encryption, air interface .....	399
20.2.4.13	Endpoint identifier .....	399
20.2.4.14	Energy economy group .....	399
20.2.4.15	Energy economy startpoint .....	400
20.2.4.16	FCS flag .....	400
20.2.4.17	Half slot condition .....	400
20.2.4.18	Half slot content .....	400
20.2.4.19	Half slot importance .....	400
20.2.4.20	Half slot position .....	400
20.2.4.21	Half slot synchronization .....	400
20.2.4.22	Handle to the request .....	400
20.2.4.22a	Lower layer resource availability .....	400
20.2.4.23	Main address .....	401
20.2.4.24	MLE activity indicator .....	401
20.2.4.25	New endpoint identifier .....	401
20.2.4.26	Number of timeslots .....	401
20.2.4.27	Operating mode .....	401
20.2.4.28	Path loss .....	401
20.2.4.29	PDU priority .....	401
20.2.4.29a	Periodic reporting timer .....	402
20.2.4.30	Quality indication .....	402
20.2.4.31	Quality of Service (QoS) .....	402
20.2.4.32	Reconnection result .....	403
20.2.4.33	Report .....	403
20.2.4.34	Scanning measurement method .....	403
20.2.4.35	SCCH information .....	404
20.2.4.36	Scrambling code .....	404
20.2.4.37	Set-up report .....	404
20.2.4.38	Stealing permission .....	404
20.2.4.39	Stealing repeats flag .....	404
20.2.4.40	Stolen indication .....	404
20.2.4.41	Subscriber class .....	404
20.2.4.42	Threshold level .....	405
20.2.4.43	Threshold values .....	405
20.2.4.44	TL-SDU .....	405
20.2.4.45	TL-SDU length .....	405
20.2.4.46	TM-SDU .....	405
20.2.4.47	TM-SDU length .....	405
20.2.4.47a	User device .....	405
20.2.4.48	Valid addresses .....	405
20.3	Services provided by LLC .....	405
20.3.1	Services at the TLA-SAP .....	405
20.3.2	Services at the TLB-SAP .....	406
20.3.3	Services at the TLC-SAP .....	406
20.3.4	LLC service primitives .....	407
20.3.5	Service primitive descriptions .....	407
20.3.5.1	Primitives at the TLA-SAP (MLE-LLC) .....	408
20.3.5.1.1	TL-CANCEL primitive .....	408
20.3.5.1.2	TL-CONNECT primitive .....	408
20.3.5.1.3	TL-DATA primitive for the advanced link .....	409
20.3.5.1.4	TL-DATA primitive for the basic link .....	409
20.3.5.1.5	TL-DISCONNECT primitive .....	410
20.3.5.1.5a	TL-RECEIVE primitive (TLA-SAP) .....	411

20.3.5.1.6	TL-RECONNECT primitive .....	411
20.3.5.1.7	TL-RELEASE primitive.....	411
20.3.5.1.8	TL-REPORT primitive (TLA-SAP) .....	412
20.3.5.1.9	TL-UNITDATA primitive.....	412
20.3.5.2	Signals at the TLA-SAP (MLE-LLC).....	413
20.3.5.3	Primitives at the TLB-SAP (MLE-LLC).....	413
20.3.5.3.1	TL-SYNC primitive.....	414
20.3.5.3.2	TL-SYSINFO primitive.....	414
20.3.5.4	Primitives at the TLC-SAP (MLE-LLC).....	414
20.3.5.4.1	TL-CONFIGURE primitive .....	415
20.3.5.4.2	TL-MEASUREMENT primitive.....	415
20.3.5.4.3	TL-MONITOR primitive.....	415
20.3.5.4.4	TL-MONITOR-LIST primitive.....	416
20.3.5.4.5	TL-REPORT primitive (TLC-SAP) .....	416
20.3.5.4.6	TL-SCAN primitive.....	416
20.3.5.4.7	TL-SCAN-REPORT primitive.....	416
20.3.5.4.8	TL-SELECT primitive.....	417
20.3.6	State diagram for the basic link .....	417
20.3.7	State diagram for advanced link .....	418
20.4	Services provided by the MAC .....	418
20.4.1	Services at the TMA-SAP.....	419
20.4.1.1	Service primitives at the TMA-SAP .....	419
20.4.1.1.1	TMA-CANCEL primitive .....	419
20.4.1.1.2	TMA-RELEASE primitive.....	419
20.4.1.1.3	TMA-REPORT primitive .....	420
20.4.1.1.4	TMA-UNITDATA primitive.....	420
20.4.1.2	Signals at the TMA-SAP.....	420
20.4.1.3	Mapping of the service primitives between LLC and MAC under the TxA-SAP.....	422
20.4.2	Service provided at the TMB-SAP .....	422
20.4.3	Service provided at the TMC-SAP .....	423
20.4.4	Service provided at the TMD-SAP .....	423
20.4.4.1	Service primitives and parameters at the TMD-SAP .....	424
20.4.4.1.1	TMD-REPORT primitive .....	424
20.4.4.1.2	TMD-UNITDATA primitive.....	424
21	Layer 2 PDU description.....	424
21.1	DLL PDU structure .....	425
21.1.1	DLL overhead.....	425
21.1.2	LLC PDUs structure .....	425
21.1.2.1	LLC header .....	425
21.1.2.2	Format of LLC header.....	425
21.1.2.3	LLC FCS.....	425
21.1.3	MAC PDUs structure.....	426
21.1.3.1	MAC overhead.....	426
21.1.3.2	Format of the MAC header .....	426
21.1.3.2.1	MAC type .....	426
21.1.3.2.2	MAC information .....	426
21.1.3.2.3	MAC address .....	426
21.1.4	DLL PDU building .....	427
21.1.4.1	Basic link illustration .....	427
21.1.4.2	Advanced link illustration .....	427
21.1.5	PDU description format.....	428
21.2	Logical Link Control (LLC) PDUs description.....	428
21.2.1	LLC PDU types .....	428
21.2.2	Basic link PDU definitions .....	429
21.2.2.1	BL-ACK.....	429
21.2.2.2	BL-ADATA .....	430
21.2.2.3	BL-DATA .....	430
21.2.2.4	BL-UDATA .....	431
21.2.3	Advanced link PDU definitions .....	431
21.2.3.1	AL-ACK, AL-RNR.....	432
21.2.3.2	AL-FINAL, AL-FINAL-AR .....	434

21.2.3.3	AL-DATA, AL-DATA-AR .....	434
21.2.3.4	AL-DISC .....	435
21.2.3.4a	AL-RECONNECT .....	436
21.2.3.5	AL-SETUP .....	436
21.2.3.6	AL-UDATA .....	438
21.2.3.7	AL-UFINAL .....	439
21.3	LLC elements .....	439
21.3.1	FCS .....	439
21.3.2	TL-SDU size .....	439
21.4	MAC PDU description .....	440
21.4.1	MAC PDU types .....	440
21.4.2	TMA-SAP: MAC PDU structure for the uplink .....	441
21.4.2.1	MAC-ACCESS .....	441
21.4.2.2	MAC-END-HU .....	443
21.4.2.3	MAC-DATA .....	444
21.4.2.4	MAC-FRAG (uplink) .....	445
21.4.2.5	MAC-END (uplink) .....	446
21.4.3	TMA-SAP: MAC PDU structure for the downlink .....	446
21.4.3.1	MAC-RESOURCE .....	447
21.4.3.2	MAC-FRAG (downlink) .....	448
21.4.3.3	MAC-END (downlink) .....	449
21.4.4	TMB-SAP: MAC PDU structure for broadcast .....	450
21.4.4.1	SYSINFO .....	451
21.4.4.2	SYNC .....	454
21.4.4.3	ACCESS-DEFINE .....	456
21.4.5	TMD-SAP: MAC PDU structure for U-plane signalling .....	457
21.4.6	TMD-SAP: MAC PDU structure for U-plane traffic .....	457
21.4.7	MAC PDU structure for access assignment broadcast .....	458
21.5	MAC elements .....	459
21.5.1	Access field .....	459
21.5.2	Channel allocation .....	460
21.5.3	Power control .....	461
21.5.4	Reservation requirement .....	462
21.5.5	TS_COMMON_FRAMES .....	462
21.5.6	Slot granting .....	463
22	LLC protocol .....	463
22.1	Overview of LLC .....	463
22.1.1	LLC protocol .....	463
22.1.2	Communication routes of the LLC model .....	464
22.2	Scenarios on LLC procedures .....	467
22.2.1	Basic link mode .....	467
22.2.1.1	Acknowledged PDU transfer (BL-DATA + BL-ACK) .....	467
22.2.1.2	Unacknowledged data transfer (BL-UDATA PDU) .....	470
22.2.1.3	Unacknowledged data transfer with presence indication (BL-DATA + BL-ACK PDU) .....	471
22.2.2	Advanced link .....	472
22.2.2.1	Setting up the connection mode (AL-SETUP PDU) .....	472
22.2.2.2	Setting up the unacknowledged transfer mode (AL-SETUP PDU) .....	474
22.2.2.3	Data exchange in the connection mode (AL-DATA PDU) .....	475
22.2.2.4	Data exchange in the unacknowledged transfer mode (AL-UDATA PDU) .....	478
22.2.2.5	Window mechanism .....	479
22.2.2.6	Selective re-transmission of segments (AL-ACK) .....	480
22.2.2.7	Flow control .....	481
22.2.2.8	Connection reset .....	482
22.2.2.8a	Reconnecting the advanced link (AL-RECONNECT PDU) .....	482
22.2.2.9	Releasing the acknowledged advanced link (AL-DISC PDU) .....	483
22.2.2.10	Releasing the unacknowledged advanced link (AL-DISC PDU) .....	483
22.3	LLC procedures .....	484
22.3.1	Common procedures for all services .....	484
22.3.1.1	End-point identifiers and handle to the request .....	484
22.3.1.2	Addressing .....	485
22.3.1.3	User data buffering .....	485

22.3.1.4	Cancelling SDU transmission .....	485
22.3.1.5	Extended error protection.....	486
22.3.1.6	Timers and counters .....	486
22.3.1.7	Formatter protocol.....	486
22.3.1.7.1	MS formatter receiving entity.....	486
22.3.1.7.2	MS formatter sending entity .....	486
22.3.2	Basic link procedures.....	487
22.3.2.1	Establishment of information transfer in basic link .....	487
22.3.2.2	Quality of service selection .....	487
22.3.2.3	Acknowledged data transmission in basic link .....	488
22.3.2.4	Unacknowledged data transfer in the basic link.....	491
22.3.2.4.1	Actions on TL-UNITDATA request (sending entity) .....	491
22.3.2.4.2	Actions on BL-UDATA PDU (receiving entity).....	492
22.3.3	Advanced link procedures for the acknowledged service.....	492
22.3.3.1	Advanced link establishment for the acknowledged service.....	493
22.3.3.1.1	Actions on TL-CONNECT request (set-up phase sending entity) .....	493
22.3.3.1.2	Actions on AL-SETUP PDU reception (set-up phase receiving entity).....	494
22.3.3.1.3	Actions on AL-SETUP PDU reception (data transfer state).....	495
22.3.3.2	Acknowledged data transfer.....	495
22.3.3.2.1	Segmentation and sequencing .....	495
22.3.3.2.2	Re-assembly .....	496
22.3.3.2.3	Acknowledgement and segment re-transmission mechanisms.....	496
22.3.3.2.4	TL-SDU re-transmission .....	497
22.3.3.2.5	Flow control .....	497
22.3.3.2.6	Actions on TL-DATA request (sending entity) .....	498
22.3.3.2.7	Data reception from the peer entity (receiving entity).....	499
22.3.3.3	Release of acknowledged service advanced link.....	500
22.3.3.3.1	Actions on TL-DISCONNECT request (MS sending entity) .....	500
22.3.3.3.2	Actions on AL-DISC PDU reception (MS receiving entity).....	501
22.3.3.4	Abnormal release of advanced link .....	501
22.3.3.5	Reconnection of acknowledged service advanced link .....	502
22.3.4	Advanced link procedures for unacknowledged service.....	502
22.3.4.1	Advanced link unacknowledged service establishment .....	502
22.3.4.2	Reception of unacknowledged service data .....	503
22.3.4.3	Sliding SDU window in unacknowledged service .....	503
22.3.4.4	Disconnection of unacknowledged data transfer.....	503
22.3.5	Channel change request handling .....	504
23	MAC protocol .....	504
23.1	MAC services.....	505
23.1.1	Functions of MAC .....	505
23.1.2	Service primitives .....	505
23.1.2.1	Services at the TMA-SAP.....	506
23.1.2.1.1	Reports.....	506
23.1.2.1.2	Buffering mechanism .....	507
23.1.2.1.3	Usage of signals.....	507
23.1.2.1.4	Priority and subscriber class .....	509
23.1.2.2	Services at the TMB-SAP .....	509
23.1.2.3	Services at the TMC-SAP .....	509
23.1.2.4	Services at the TMD-SAP .....	509
23.1.2.5	Use of endpoint identifiers .....	510
23.1.3	MS capabilities .....	510
23.1.3.1	Frequency half duplex operation.....	510
23.1.3.1.1	Frequency half duplex capability.....	510
23.1.3.1.2	Fast switching capability .....	511
23.1.3.2	Frequency full duplex operation .....	511
23.1.3.3	Basic capabilities of the physical layer .....	512
23.2	Services provided by the lower MAC .....	512
23.2.1	Services at the TMV-SAP.....	512
23.2.2	PDU mapping of the logical channels at the TMV-SAP .....	514
23.3	Control channel usage .....	514
23.3.1	Control channel types .....	514

23.3.1.1	MCCH.....	514
23.3.1.2	SCCH.....	515
23.3.1.2.1	Common SCCH.....	515
23.3.1.2.2	Assigned SCCH.....	516
23.3.1.3	ACCH.....	517
23.3.1.4	Monitoring pattern during multi-timeslot traffic operation.....	518
23.3.2	Discontinuous transmission.....	519
23.3.2.1	Carrier sharing operation.....	519
23.3.2.2	MCCH sharing operation.....	519
23.3.2.3	Traffic carrier sharing operation.....	520
23.3.3	Minimum mode operation.....	520
23.3.3.1	Beginning of minimum mode.....	520
23.3.3.2	MS operation during frames 1 to 17.....	521
23.3.3.3	MS operation during frame 18.....	521
23.3.3.4	MS operation in energy economy or dual watch mode.....	521
23.3.3.5	End of minimum mode.....	522
23.3.3.6	Restrictions on usage of minimum mode.....	522
23.3.4	Independent allocation of uplink and downlink.....	522
23.3.5	Usage of a multi-slot channel.....	523
23.4	General MAC procedures.....	523
23.4.1	PDU header analysis for signalling messages.....	523
23.4.1.1	MAC PDU types.....	523
23.4.1.2	Addressing at the TMA-SAP.....	523
23.4.1.2.1	Downlink message.....	524
23.4.1.2.2	Uplink message.....	525
23.4.1.2.3	Event labels.....	525
23.4.1.2.4	Usage of SMI.....	528
23.4.1.2.5	Usage of USSI.....	528
23.4.1.3	Addressing at the TMB-SAP.....	529
23.4.1.4	Addressing at the TMD-SAP.....	529
23.4.2	PDU composition for signalling messages.....	529
23.4.2.1	Fragmentation (TMA-SAP only).....	530
23.4.2.1.1	Fragmentation of downlink TM-SDU.....	530
23.4.2.1.2	Fragmentation of uplink TM-SDU.....	531
23.4.2.1.3	Fragmentation in minimum mode.....	533
23.4.2.1.4	Fragmentation on time-shared control channel.....	534
23.4.2.1.5	Fragmentation on assigned channel if downlink is in SACCH.....	534
23.4.2.1.6	Fragmentation on assigned channel if downlink is in FACCH or assigned SCCH.....	535
23.4.2.1.7	Fragmentation on stealing channel.....	536
23.4.2.2	Fill bit addition.....	536
23.4.2.3	PDU association.....	536
23.4.3	PDU decomposition for signalling messages.....	538
23.4.3.1	Reconstruction (TMA-SAP only).....	538
23.4.3.1.1	Reconstruction of downlink TM-SDU.....	538
23.4.3.1.2	Reconstruction of uplink TM-SDU.....	538
23.4.3.1.3	Reconstruction in minimum mode.....	540
23.4.3.1.4	Reconstruction on time-shared control channel.....	540
23.4.3.1.5	Reconstruction on assigned channel if downlink is in SACCH.....	541
23.4.3.1.6	Reconstruction on assigned channel if downlink is in FACCH or assigned SCCH.....	542
23.4.3.1.7	Reconstruction on stealing channel.....	543
23.4.3.2	Fill bit deletion.....	543
23.4.3.3	PDU dissociation.....	543
23.4.3.4	PDU error detection.....	544
23.4.4	Power control.....	544
23.4.4.1	Overall process.....	544
23.4.4.2	MS open loop power control.....	545
23.4.4.3	MS closed loop power control.....	545
23.4.5	MS linearization.....	546
23.4.6	BS synchronization.....	547
23.5	PDU transfer for signalling messages (TMA-SAP).....	547
23.5.1	Random access protocol.....	547
23.5.1.1	Introduction.....	547

23.5.1.2	Overview .....	547
23.5.1.3	Access control facilities for BS .....	549
23.5.1.3.1	Transmission of ACCESS-DEFINE and ACCESS-ASSIGN PDU .....	550
23.5.1.3.2	BS response to access request .....	550
23.5.1.3.3	Reserving subslots on uplink .....	551
23.5.1.4	MS-MAC random access protocol.....	551
23.5.1.4.1	Reception of ACCESS-DEFINE PDU .....	551
23.5.1.4.2	Reception of ACCESS-ASSIGN PDU .....	552
23.5.1.4.3	Initiating a random access .....	552
23.5.1.4.4	Checking for appropriate access code .....	553
23.5.1.4.5	First try procedure .....	554
23.5.1.4.6	Choosing from a new access frame .....	554
23.5.1.4.7	Counting subslots in an access frame .....	554
23.5.1.4.8	Re-try procedure .....	555
23.5.1.4.9	Abandoning random access attempt .....	556
23.5.1.4.10	Random access operation after acquiring main carrier .....	556
23.5.1.4.11	Random access operation on a new channel.....	557
23.5.1.4.12	Random access operation on ACCH .....	557
23.5.1.4.13	Random access operation in minimum mode .....	557
23.5.1.4.14	Random access operation on time-shared control channel .....	558
23.5.1.4.15	Random access operation on CSS channel .....	558
23.5.1.4.16	Random access operation with extended random access channel .....	559
23.5.2	Reserved access .....	560
23.5.2.1	Reservation requirement .....	560
23.5.2.2	Slot granting .....	561
23.5.2.2.1	Slot granting in normal mode .....	562
23.5.2.2.2	Slot granting in minimum mode .....	562
23.5.2.2.3	Slot granting on time-shared control channel .....	563
23.5.2.2.4	BS slot granting operation .....	563
23.5.2.3	Use of reserved slots .....	564
23.5.2.3.1	Individual address or event label .....	564
23.5.2.3.2	Group address.....	565
23.5.2.4	Reverting to random access.....	565
23.5.2.5	Example of reservation process.....	565
23.5.3	Cancel request.....	566
23.5.4	Channel allocation .....	566
23.5.4.1	Transmission of channel allocation .....	566
23.5.4.2	Reception of channel allocation .....	567
23.5.4.2.1	Channel allocation types.....	567
23.5.4.2.2	Reception of channel allocation on MCCH or common SCCH .....	569
23.5.4.2.3	Reception of channel allocation on assigned channel.....	571
23.5.4.2.4	Reception of channel allocation on CSS channel .....	573
23.5.4.3	Channel change .....	575
23.5.4.3.1	Timing of channel change .....	575
23.5.4.3.2	Use of "timeslot assigned" .....	578
23.5.4.3.3	Use of "up/downlink assigned" .....	578
23.5.4.3.4	CLCH permission .....	579
23.5.4.3.5	Monitoring pattern information .....	579
23.5.5	Usage marker assignment .....	580
23.5.6	Maintenance of assigned channel .....	581
23.5.6.1	Criteria for leaving assigned channel .....	581
23.5.6.1.1	Checking of AACH .....	581
23.5.6.1.2	Inactivity time-out .....	582
23.5.6.2	Criteria for leaving carrier specific signalling channel .....	583
23.5.6.3	Traffic on downlink for other users.....	584
23.6	PDU transfer for broadcast messages (TMB-SAP) .....	585
23.6.1	Broadcast channels .....	585
23.6.2	Acquiring cell synchronization .....	585
23.6.3	Acquiring network information .....	586
23.7	Layer management communication (TMC-SAP).....	586
23.7.1	Path loss calculation.....	586
23.7.1.1	Path loss parameter C1 .....	586

23.7.1.2	Path loss parameter C2.....	587
23.7.2	Cell selection .....	587
23.7.3	Serving cell measurement.....	588
23.7.3.1	Downlink measurements.....	588
23.7.3.2	Uplink measurements.....	589
23.7.4	Monitoring .....	589
23.7.4.1	Monitoring scenario .....	590
23.7.4.2	Monitoring measurements.....	590
23.7.4.3	Signal strength measurement .....	590
23.7.5	Scanning .....	591
23.7.5.1	Scanning scenario .....	591
23.7.5.2	Scanning measurement.....	592
23.7.5.2.1	Foreground scanning .....	592
23.7.5.2.2	Background scanning .....	592
23.7.5.2.3	Interrupting scanning.....	593
23.7.6	Selection of energy economy mode.....	593
23.7.7	Selection of dual watch mode with energy economy group .....	595
23.8	PDU transfer for traffic (TMD-SAP) .....	597
23.8.1	Introduction.....	597
23.8.2	Criteria for transmission and reception of traffic .....	598
23.8.2.1	Use of TMC-CONFIGURE primitive .....	598
23.8.2.2	Timing of change of mode .....	599
23.8.2.3	AACH mechanisms.....	601
23.8.2.3.1	MS transmitting traffic .....	601
23.8.2.3.2	MS receiving traffic.....	603
23.8.2.3.3	Multi-slot interleaving with interruption .....	605
23.8.3	Exchange of information at the TMD-SAP .....	605
23.8.3.1	Interface at transmitting MS.....	607
23.8.3.2	Interface at receiving MS .....	608
23.8.4	Stealing from circuit mode capacity .....	609
23.8.4.1	Uplink stealing .....	609
23.8.4.1.1	Transmission on uplink STCH .....	609
23.8.4.1.2	Criteria for uplink stealing.....	610
23.8.4.1.3	Stealing repeats mechanism.....	611
23.8.4.1.4	Reception on uplink STCH.....	611
23.8.4.2	Downlink stealing .....	612
23.8.4.2.1	Transmission on downlink STCH .....	612
23.8.4.2.2	Reception on downlink STCH.....	613
23.8.5	BS operation .....	614
24	(Void) .....	614
25	(Void) .....	614
26	(Void) .....	615
27	(Void) .....	615
28	TETRA Packet Data Protocol .....	615
28.1	Subnetwork Dependent Convergence Protocol (SNDCP) overview .....	618
28.2	SNDCP service description .....	619
28.2.1	Introduction.....	619
28.2.2	Services offered .....	619
28.2.3	Service Primitives.....	619
28.2.3.1	Primitive descriptions.....	620
28.2.3.2	Parameter descriptions .....	622
28.2.4	Definition of SNDCP states and state transitions .....	624
28.2.4.1	CLOSED .....	625
28.2.4.2	IDLE .....	625
28.2.4.3	IDLE-temporary break.....	625
28.2.4.4	STANDBY.....	625
28.2.4.5	STANDBY-temporary break .....	626
28.2.4.6	RESPONSE-WAITING.....	626
28.2.4.7	READY .....	627

28.2.4.8	READY-temporary break .....	629
28.2.5	State transitions and functions .....	629
28.2.5a	Other MLE primitives .....	634
28.2.6	STANDBY, READY and RESPONSE_WAIT timer functions .....	634
28.2.6.1	STANDBY timer function .....	634
28.2.6.2	READY timer function .....	635
28.2.6.3	RESPONSE_WAIT Timer Function .....	636
28.3	SNDCP Procedures .....	636
28.3.1	Services provided by the protocol .....	636
28.3.2	Underlying services assumed by the protocol .....	638
28.3.3	Context activation and deactivation procedures .....	638
28.3.3.1	Internet Protocol addressing support .....	639
28.3.3.1.1	IPv4 - Static and dynamic IP addresses .....	639
28.3.3.1.2	Mobile IPv4 .....	639
28.3.3.1.3	IPv6 .....	640
28.3.3.2	NSAPI usage .....	641
28.3.3.3	SNDCP network endpoint identifier .....	641
28.3.3.4	Definition of Packet data MS Types .....	642
28.3.3.4.1	Type A - Parallel .....	642
28.3.3.4.2	Type B - Alternating .....	643
28.3.3.4.3	Type C - IP single mode .....	643
28.3.3.4.4	Type D - Restricted IP single mode .....	643
28.3.3.5	PDP Context Activation Procedure .....	643
28.3.3.6	PDP context deactivation procedure .....	645
28.3.3.6.1	MS originated PDP context deactivation procedure .....	645
28.3.3.6.2	SwMI originated context deactivation procedure .....	647
28.3.4	Packet Data Channel (PDCH) handling procedures .....	647
28.3.4.1	Logical link handling .....	648
28.3.4.2	Logical link setup .....	648
28.3.4.3	Logical Link disconnection .....	655
28.3.4.4	Advanced link reconnection .....	656
28.3.4.5	Releasing the advanced link .....	660
28.3.4.6	Physical channel handling .....	660
28.3.5	Packet Data transmission and reception procedures .....	661
28.3.5.1	Acknowledged data service .....	661
28.3.5.2	Unacknowledged data service .....	667
28.3.5.2a	Usage of Resource request .....	669
28.3.5.3	Protocol header compression .....	670
28.3.5.3.1	Header compression types .....	670
28.3.5.3.2	TCP/IP header compression .....	670
28.3.5.3.3	IP header compression .....	671
28.3.5.4	Data compression .....	671
28.3.5.4.1	Support of multiple compression types .....	672
28.3.5.4.2	Management of V.42bis data compression .....	672
28.3.5.4.3	Management of BSD data compression .....	673
28.3.5.4.4	Management of Predictor data compression .....	673
28.3.6	Packet data paging mechanism .....	674
28.3.7	TETRA IP user authentication .....	675
28.3.8	TETRA Packet data over the air provisioning .....	676
28.4	SN-PDU formats .....	677
28.4.1	PDU priority .....	677
28.4.2	Maximum N-PDU size .....	678
28.4.3	PDU not supported .....	678
28.4.4	SN PDU description tables .....	678
28.4.4.1	SN-ACTIVATE PDP CONTEXT ACCEPT .....	678
28.4.4.2	SN-ACTIVATE PDP CONTEXT DEMAND .....	679
28.4.4.3	SN-ACTIVATE PDP CONTEXT REJECT .....	680
28.4.4.4	SN-DATA .....	681
28.4.4.5	SN-DATA TRANSMIT REQUEST .....	681
28.4.4.6	SN-DATA TRANSMIT RESPONSE .....	682
28.4.4.7	SN-DEACTIVATE PDP CONTEXT DEMAND .....	682
28.4.4.8	SN-DEACTIVATE PDP CONTEXT ACCEPT .....	683



28.4.4.9	SN-END OF DATA .....	683
28.4.4.10	SN-NOT SUPPORTED .....	683
28.4.4.11	SN-PAGE REQUEST .....	684
28.4.4.12	SN-PAGE RESPONSE .....	684
28.4.4.13	SN-RECONNECT .....	685
28.4.4.14	SN-UNITDATA .....	685
28.4.5	SNDCP information elements coding .....	685
28.4.5.1	Accept/Reject .....	685
28.4.5.2	Access point name index .....	686
28.4.5.3	Activation reject cause .....	686
28.4.5.4	Address Type Identifier in Demand .....	686
28.4.5.5	BSD data compression parameters .....	687
28.4.5.6	BSD compression version .....	687
28.4.5.7	BSD dictionary size .....	687
28.4.5.8	Data to send .....	687
28.4.5.9	DCOMP .....	688
28.4.5.10	DCOMP negotiation .....	688
28.4.5.11	Deactivation type .....	688
28.4.5.12	Enhanced service .....	688
28.4.5.13	Immediate service change .....	689
28.4.5.14	IP address Ipv4 .....	689
28.4.5.15	Largest header size in octets that may be compressed .....	689
28.4.5.16	Logical link status .....	689
28.4.5.17	Maximum interval between full headers .....	689
28.4.5.18	Maximum time interval between full headers .....	690
28.4.5.19	Maximum transmission unit .....	690
28.4.5.20	Not supported SN PDU type .....	690
28.4.5.21	N-PDU .....	691
28.4.5.22	NSAPI .....	691
28.4.5.23	Number of compression state slots, TCP .....	691
28.4.5.24	Number of compression state slots, non-TCP .....	691
28.4.5.25	Number of VJ compression state slots .....	691
28.4.5.26	Packet data MS Type .....	692
28.4.5.27	PCOMP .....	692
28.4.5.28	PCOMP negotiation .....	693
28.4.5.29	PD service status .....	693
28.4.5.30	PDU priority max .....	693
28.4.5.31	Protocol configuration options .....	694
28.4.5.32	READY timer .....	694
28.4.5.33	Reply requested .....	695
28.4.5.34	Resource request .....	695
28.4.5.35	RESPONSE_WAIT timer .....	696
28.4.5.36	SNDCP version .....	696
28.4.5.37	SNDCP network endpoint identifier .....	696
28.4.5.38	SN PDU type .....	697
28.4.5.39	STANDBY timer .....	697
28.4.5.40	SwMI IPv6 Information .....	697
28.4.5.41	SwMI Mobile IPv4 Information .....	698
28.4.5.42	Transmit response reject cause .....	698
28.4.5.43	Type identifier in accept .....	698
28.4.5.44	Type 3 element identifier .....	699
28.4.5.45	V.42bis compression request, P <sub>0</sub> .....	699
28.4.5.46	V.42bis data compression parameters .....	699
28.4.5.47	V.42bis maximum string length, P <sub>2</sub> .....	699
28.4.5.48	V.42bis number of codewords, P <sub>1</sub> .....	700
28.5	Timers and constants .....	700
28.5.1	Timers .....	700
28.5.1.1	PDP_ACTIVATE_WAIT .....	700
28.5.1.2	PDP_DEACTIVATE_WAIT .....	700
28.5.1.3	READY .....	700
28.5.1.4	STANDBY .....	700

28.5.1.5	Void.....	700
28.5.1.6	RESPONSE_WAIT .....	700
28.5.1.7	SERVICE_CHANGE .....	700
28.5.2	Constants .....	700
29	SDS-TL service and protocol.....	701
29.1	Overview of SDS-TL .....	702
29.1.1	Protocol architecture .....	702
29.1.2	Addressing .....	703
29.1.3	SDS-TL Requirement to SDS and STATUS services .....	703
29.1.3.1	Requirements to MS/LS .....	703
29.1.3.2	Requirements to the SwMI.....	703
29.2	SDS-TL Service Descriptions .....	703
29.2.1	Services available at the SDS-TL-SAP.....	703
29.2.2	Service primitives at the SDS-TL-SAP .....	704
29.2.3	SDS-TL primitives' parameters.....	709
29.2.4	State description.....	710
29.3	Protocol description.....	710
29.3.1	Addressing mechanism .....	710
29.3.2	Description of protocol elements .....	714
29.3.2.1	Protocol identifier .....	714
29.3.2.2	End-to-end acknowledgement types .....	715
29.3.2.3	Service selection/short form report .....	717
29.3.2.4	Storage .....	717
29.3.2.5	Message reference.....	717
29.3.2.6	Validity period .....	718
29.3.2.7	Forward address .....	718
29.3.2.8	Data coding scheme .....	718
29.3.2.9	Time stamp.....	718
29.3.2.10	User data length .....	719
29.3.3	Procedures.....	719
29.3.3.1	General description .....	719
29.3.3.2	MS sending a message .....	722
29.3.3.3	MS receiving a message.....	723
29.3.3.4	Sending an acknowledgement from the destination MS/LS .....	723
29.3.3.4.1	General .....	723
29.3.3.4.2	Positive acknowledgement from an MS/LS .....	724
29.3.3.4.3	Negative acknowledgement from an MS/LS.....	725
29.3.3.4.4	Short form acknowledge.....	725
29.3.3.5	Sending an acknowledgement from the source MS/LS .....	725
29.3.3.6	Sending an acknowledgement from the SwMI .....	726
29.3.3.6.1	General .....	726
29.3.3.6.2	Positive acknowledgement from the SwMI.....	727
29.3.3.6.3	Negative acknowledgement from the SwMI .....	727
29.3.3.6.4	Temporary negative acknowledgement from the SwMI .....	727
29.3.3.7	Sending an acknowledgement from the SwMI to destination MS/LS .....	727
29.3.3.8	Using SDS-TL for system broadcast messages.....	728
29.3.3.8.1	General .....	728
29.3.3.8.2	Sending a broadcast message .....	728
29.3.3.8.3	Receiving a broadcast message .....	728
29.4	Coding requirements .....	729
29.4.1	PDU general structure.....	729
29.4.2	PDU Descriptions .....	729
29.4.2.1	SDS-ACK .....	729
29.4.2.2	SDS-REPORT.....	730
29.4.2.3	SDS-SHORT REPORT.....	731
29.4.2.4	SDS-TRANSFER.....	731
29.4.3	Information elements coding .....	732
29.4.3.1	Acknowledgement required .....	732
29.4.3.2	Delivery status.....	733
29.4.3.3	Delivery report request.....	734
29.4.3.4	Dummy digit .....	735

29.4.3.5	Forward address type .....	735
29.4.3.6	Forward address .....	735
29.4.3.7	Message reference .....	735
29.4.3.8	Message type.....	736
29.4.3.9	Protocol identifier .....	736
29.4.3.10	Service selection/short form report .....	738
29.4.3.11	Short report type.....	738
29.4.3.12	Storage .....	738
29.4.3.13	User data .....	738
29.4.3.14	Validity period .....	739
29.5	Protocol specific definitions .....	739
29.5.1	Standardized protocols using SDS Type 4 without SDS-TL .....	739
29.5.1.1	Protocol sequences .....	739
29.5.1.2	PDU Description tables.....	739
29.5.2	Simple text messaging .....	740
29.5.2.1	Protocol sequences.....	740
29.5.2.2	PDU description tables.....	740
29.5.2.3	Simple text messaging.....	740
29.5.3	Text messaging using SDS-TL .....	740
29.5.3.1	Protocol sequences .....	741
29.5.3.2	PDU description tables.....	741
29.5.3.3	Text message transfer SDU.....	741
29.5.3.4	Text message short form acknowledgement .....	741
29.5.4	Text messaging information elements .....	741
29.5.4.1	Text coding scheme.....	741
29.5.4.2	Character packing .....	742
29.5.4.3	7-bit alphabet table.....	745
29.5.4.4	Time stamp.....	746
29.5.4.5	Timestamp used .....	746
29.5.5	Simple GPS.....	746
29.5.5.1	Protocol sequences .....	746
29.5.5.2	PDU description tables.....	746
29.5.5.3	Simple GPS unitdata .....	746
29.5.6	GPS using SDS-TL data transfer services .....	747
29.5.6.1	Protocol sequences .....	747
29.5.6.2	PDU description tables.....	747
29.5.6.3	GPS transfer SDU .....	747
29.5.7	GPS coding scheme .....	747
29.5.8	Wireless Application Protocol (WAP).....	748
29.5.8.1	Protocol sequences .....	748
29.5.8.2	PDU description tables.....	748
<b>Annex A (normative): LLC timers and constants.....</b>		<b>749</b>
A.1	LLC timers .....	749
A.2	LLC constants .....	750
<b>Annex B (normative): MAC timers and constants.....</b>		<b>752</b>
B.1	MAC timers.....	752
B.2	MAC constants.....	753
<b>Annex C (normative): Mathematical definition of Frame Check Sequence (FCS).....</b>		<b>754</b>
<b>Annex D (informative): MAC scenarios for use of traffic channel .....</b>		<b>755</b>
<b>Annex E (normative): PDU encoding rules and examples .....</b>		<b>765</b>
E.1	PDU encoding rules for CMCE, MM and SNDCP PDUs .....	765
E.1.1	General PDU encoding rules for CMCE, MM and SNDCP PDUs .....	765
E.1.2	PDU encoding examples for CMCE PDUs.....	770
E.1.3	PDU encoding examples for MM PDUs .....	772

E.2	PDU encoding rules for MLE PDUs .....	775
E.2.1	General PDU encoding rules for MLE PDUs.....	775
E.2.2	PDU encoding examples for MLE PDUs.....	777
<b>Annex F (normative):</b>	<b>TETRA frequency bands, duplex spacings and channel numbering .....</b>	<b>782</b>
<b>Annex G (normative):</b>	<b>TETRA group management scenarios.....</b>	<b>783</b>
G.1	General requirements .....	783
G.2	MS-INITIATED GROUP ATTACHMENT/DETACHMENT .....	785
G.2.1	SCENARIO 1 .....	785
G.2.2	SCENARIO 2 .....	786
G.2.3	SCENARIO 3 .....	786
G.2.4	SCENARIO 4 .....	787
G.2.5	SCENARIO 5 .....	787
G.2.6	SCENARIO 6 .....	788
G.2.7	SCENARIO 7 .....	789
G.2.8	SCENARIO 8 .....	791
G.2.9	SCENARIO 9 .....	791
G.2.10	SCENARIO 10 .....	793
G.2.11	SCENARIO 11 .....	794
G.2.12	SCENARIO 12 .....	795
G.2.13	SCENARIO 13 .....	796
G.3	SwMI-INITIATED GROUP ATTACHMENT/DETACHMENT .....	797
<b>Annex H (normative):</b>	<b>TETRA proprietary information element owner .....</b>	<b>799</b>
H.1	Proprietary information element .....	799
H.2	Application for the proprietary element owner value.....	799
<b>Annex I (normative):</b>	<b>Void .....</b>	<b>802</b>
<b>Annex J (normative):</b>	<b>TETRA SDS-TL protocol identifier information element owner .....</b>	<b>803</b>
J.1	Protocol identifier information element .....	803
J.2	Application for the protocol identifier value .....	803
<b>Annex K (informative):</b>	<b>TETRA Mobile Country Code information element values .....</b>	<b>806</b>
K.1	Management of TETRA Mobile Country Codes .....	806
K.2	TETRA Mobile Country Code information element values .....	806
<b>Annex L (informative):</b>	<b>Bibliography.....</b>	<b>810</b>
<b>Annex M (Informative):</b>	<b>Change Requests .....</b>	<b>811</b>
History	.....	813

---

## Intellectual Property Rights

IPRs essential or potentially essential to the present document may have been declared to ETSI. The information pertaining to these essential IPRs, if any, is publicly available for **ETSI members and non-members**, and can be found in ETSI SR 000 314: "*Intellectual Property Rights (IPRs); Essential, or potentially Essential, IPRs notified to ETSI in respect of ETSI standards*", which is available from the ETSI Secretariat. Latest updates are available on the ETSI Web server (<http://webapp.etsi.org/IPR/home.asp>).

Pursuant to the ETSI IPR Policy, no investigation, including IPR searches, has been carried out by ETSI. No guarantee can be given as to the existence of other IPRs not referenced in ETSI SR 000 314 (or the updates on the ETSI Web server) which are, or may be, or may become, essential to the present document.

---

## Foreword

This Technical Specification (TS) has been produced by ETSI Project Terrestrial Trunked Radio (TETRA).

The present document is part 2 of a multipart deliverable covering the Terrestrial Trunked Radio (TETRA); Voice plus Data (V+D), as identified below:

- EN 300 392-1: "General network design";
- EN 300 392-2: "Air Interface (AI)";**
- EN 300 392-3: "Interworking at the Inter-System Interface (ISI)";
- ETS 300 392-4: "Gateways basic operation";
- EN 300 392-5: "Peripheral Equipment Interface (PEI)";
- EN 300 392-7: "Security";
- EN 300 392-9: "General requirements for supplementary services";
- EN 300 392-10: "Supplementary services stage 1";
- EN 300 392-11: "Supplementary services stage 2";
- EN 300 392-12: "Supplementary services stage 3";
- ETS 300 392-13 "SDL model of the Air Interface (AI)";
- ETS 300 392-14 " Protocol Implementation Conformance Statement (PICS) proforma specification";
- TS 100 392-15: "TETRA frequency bands, duplex spacings and channel numbering";
- TS 100 392-16: "Network Performance Metrics";
- TS 100 392-17: "TETRA V+D and DMO Release 1.1 specifications".

NOTE: Part 13 (SDL) and part 14 (PICS) of this multipart deliverable are of status "historic" and will not be updated according this version of the standard.

---

# 1 Scope

The present document defines the Terrestrial Trunked Radio (TETRA) system supporting Voice plus Data (V+D). It specifies the air interface, the interworking between TETRA systems and to other systems via gateways, the Terminal Equipment (TE) interface on the Mobile Station (MS), the connection of Line Stations (LSs) to the infrastructure, the security aspects in TETRA networks, the management services offered to the operator, the performance objectives, and the supplementary services that come in addition to the basic and teleservices.

This part applies to the TETRA V+D Air Interface (AI) and contains the specifications of the physical layer, the data link layer and the network layer according to the ISO model.

First, it establishes the TETRA radio aspects (layer 1):

- it defines and specifies the modulation;
- it defines and specifies the radio transmission and reception;
- it defines and specifies the synchronization;
- it defines and specifies the channel coding;
- it defines and specifies the channel multiplexing;
- it defines and specifies the control over the radio link.

Secondly, it establishes the services, messages and protocols used for voice and circuit mode data transfer, starting with the upper layers:

- it defines and specifies the protocol used by the Circuit Mode Control Entity (CMCE) to communicate across the air interface in order to offer the services of the Call Control (CC), Supplementary Service (SS) and Short Data Service (SDS) sub-entities;
- it defines and specifies the services provided by the CC sub-entity;
- it defines and specifies the services provided by the SS sub-entity;
- it defines and specifies the services provided by the SDS sub-entity;
- it defines and specifies the services and protocol used for the management of the users' mobility inside and across TETRA networks, namely the ones of the Mobility Management (MM) entity and the MLE;
- it defines and specifies the services and protocol used in the data link layer subdivided in two sub-entities, the Logical Link Control (LLC) and the Medium Access Control (MAC) entities.

Thirdly, it establishes the services, messages and protocols used for packet data transfer:

- it defines and specifies the services provided by the Sub-Network Specific Data Control Protocol (SNDCP) sub-entity;
- it defines and specifies the protocol used by Sub-Network Specific Data Control Protocol (SNDCP).

The normative annexes mainly specify the parameter values used in the protocol.

The informative annexes refer mainly to the description of more general layer 3 to layer 1 mechanism.

---

## 2 References

The following documents contain provisions which, through reference in this text, constitute provisions of the present document.

- References are either specific (identified by date of publication and/or edition number or version number) or non-specific.
- For a specific reference, subsequent revisions do not apply.
- For a non-specific reference, the latest version applies.

Referenced documents which are not found to be publicly available in the expected location might be found at <http://docbox.etsi.org/Reference>.

- [1] ITU-T Recommendation X.25: "Interface between Data Terminal Equipment (DTE) and Data Circuit-terminating Equipment (DCE) for terminals operating in the packet mode and connected to public data networks by dedicated circuit".
- [2] ISO/IEC 13239: "Information technology - Telecommunications and information exchange between systems - High-level data link control (HDLC) procedures - Frame structure".
- [3] ETSI TS 100 900: "Digital cellular telecommunications system (Phase 2+) (GSM); Alphabets and language-specific information (GSM 03.38 version 7.2.0 Release 1998)".
- [4] ISO/IEC 8348: "Information technology - Open Systems Interconnection - Network Service Definition".
- [5] Void.
- [6] Void.
- [7] Void.
- [8] ETSI EN 300 113-1: "Radio Equipment and Systems (RES); Land mobile service; Technical characteristics and test conditions for radio equipment intended for the transmission of data (and speech) and having an antenna connector; Part 1: Technical characteristics and methods of measurement".
- [9] ETSI EN 300 392-1: "Terrestrial Trunked Radio (TETRA); Voice plus Data (V+D); Part 1: General network design".
- [10] ETSI ETS 300 125: "Integrated Services Digital Network (ISDN); User-network interface data link layer specification; Application of CCITT Recommendations Q.920/I.440 and Q.921/I.441".
- [11] ETSI EN 300 392-7: "Terrestrial Trunked Radio (TETRA); Voice plus Data (V+D); Part 7: Security".
- [12] ETSI EN 300 392-9: "Terrestrial Trunked Radio (TETRA); Voice plus Data (V+D); Part 9: General requirements for supplementary services".
- [13] ETSI EN/ETS 300 392-12 (all subparts): "Terrestrial Trunked Radio (TETRA); Voice plus Data (V+D); Part 12: Supplementary services stage 3".
- [14] ETSI ETS 300 396-5: "Terrestrial Trunked Radio (TETRA); Technical requirements for Direct Mode Operation (DMO); Part 5: Gateway air interface".
- [15] Void
- [16] ETSI EN 300 392-12-1: "Terrestrial Trunked Radio (TETRA); Voice plus Data (V+D); Part 12: Supplementary services stage 3; Call Identification (CI)".
- [17] ETSI EN 300 392-12-3: "Terrestrial Trunked Radio (TETRA); Voice plus Data (V+D); Part 12: Supplementary services stage 3; Sub-part 3: Talking Party Identification (TPI)".

- [18] IETF RFC 1144: "Compressing TCP/IP headers for low-speed serial links".
- [19] ITU-T Recommendation V.42bis: "Data compression procedures for data circuit-terminating equipment (DCE) using error correcting procedures".
- [20] ETSI EN 300 396-10: "Terrestrial Trunked Radio (TETRA); Technical requirements for Direct Mode Operation (DMO); Part 10: Managed Direct Mode Operation (M-DMO)".
- [21] IETF RFC 1661: "The Point-to-Point Protocol (PPP)".
- [22] IETF RFC 1994: "PPP Challenge Handshake Authentication Protocol (CHAP)".
- [23] IETF RFC 2865: "Remote Authentication Dial In User Service (RADIUS)".
- [24] IETF RFC 3232: "Assigned Numbers".
- [25] Void.
- [26] Void.
- [27] ISO/IEC 8859 (all parts): "Information technology - 8-bit single-byte coded graphic character sets".
- [28] ISO/IEC 10646-1: "Information technology - Universal Multiple-Octet Coded Character Set (UCS) - Part 1: Architecture and Basic Multilingual Plane".
- [29] National Marine Electronics Association: "NMEA 0183 Interface Standard".
- [30] Radio Technical Commission for Maritime Services: "RCTM SpecialCommittee104 on GLobal Navigation Satellite Systems (GNSS) Service".
- [31] ETSI EN 300 392-3-5: "Terrestrial Trunked Radio (TETRA); Voice plus Data (V+D); Part 3: Interworking at the Inter-System Interface (ISI); Sub-part 5: Additional Network Feature for Mobility Management (ANF-ISIMM)".
- [32] ETSI EN 300 392-10-8: "Terrestrial Trunked Radio (TETRA); Voice plus Data (V+D); Part 10: Supplementary services stage 1; Sub-part 8: Area selection (AS)".
- [33] ETSI EN 300 392-11-8: "Terrestrial Trunked Radio (TETRA); Voice plus Data (V+D); Part 11: Supplementary services stage 2; Sub-part 8: Area Selection (AS)".
- [34] ETSI EN 300 392-12-8: "Terrestrial Trunked Radio (TETRA); Voice plus Data (V+D); Part 12: Supplementary services stage 3; Sub-part 8: Area Selection (AS)".
- [35] ETSI ETS 300 396-3: "Terrestrial Trunked Radio (TETRA); Technical requirements for Direct Mode Operation (DMO); Part 3: Mobile Station to Mobile Station (MS-MS) Air Interface (AI) protocol".
- [36] ETSI EN 300 396-4: "Terrestrial Trunked Radio (TETRA); Technical requirements for Direct Mode Operation (DMO); Part 4: Type 1 repeater air interface".
- [37] ETSI EN 300 396-6: "Terrestrial Trunked Radio (TETRA); Direct Mode Operation (DMO); Part 6: Security".
- [38] ETSI EN 300 396-7: "Terrestrial Trunked Radio (TETRA); Technical requirements for Direct Mode Operation (DMO); Part 7: Type 2 repeater air interface".
- [39] WAP Forum WAP-100: "Wireless Application Protocol Architecture Specification".
- [40] ETSI ETS 300 395-2: "Terrestrial Trunked Radio (TETRA); Speech codec for full-rate traffic channel; Part 2: TETRA codec".
- [41] Void.
- [42] ETSI ETS 300 392-10-7: "Terrestrial Trunked Radio (TETRA); Voice plus Data (V+D); Part 10: Supplementary services stage 1; Sub-part 7: Short number addressing".



- [43] ETSI EN 300 392-12-10: "Terrestrial Trunked Radio (TETRA); Voice plus Data (V+D); Part 12: Supplementary services stage 3; Sub-part 10: Priority Call (PC)".
- [44] ETSI EN 300 392-12-16: "Terrestrial Trunked Radio (TETRA); Voice plus Data (V+D); Part 12: Supplementary services stage 3; Sub-part 16: Pre-emptive Priority Call (PPC)".
- [45] ETSI ETS 300 392-12-7: "Terrestrial Trunked Radio (TETRA); Voice plus Data (V+D); Part 12: Supplementary services stage 3; Sub-part 7: Short Number Addressing (SNA)".
- [46] ETSI EN 300 392-12-22: "Terrestrial Trunked Radio (TETRA); Voice plus Data (V+D); Part 12: Supplementary services stage 3; Sub-part 22: Dynamic Group Number Assignment (DGNA)".
- [47] ETSI EN 300 392-5: "Terrestrial Trunked Radio (TETRA); Voice plus Data (V+D); Part 5: Peripheral Equipment Interface (PEI)".
- [48] IETF RFC 3220: "IP Mobility Support for IPv4".
- [49] ETSI TS 100 392-15: "Terrestrial Trunked Radio (TETRA) Voice plus DATA (V+D) Part 15: TETRA frequency bands, duplex spacings and channel numbering".
- [50] ETSI ETR 300-5: "Terrestrial Trunked Radio (TETRA); Voice plus Data (V+D); Designers' guide; Part 5: Guidance on Numbering and addressing".
- [51] IETF RFC 2507: "IP Header Compression".
- [52] IETF RFC 2508: "Compressing IP/UDP/RTP Headers for Low-Speed Serial Links".
- [53] IETF RFC 1977: "PPP BSD Compression Protocol".
- [54] IETF RFC 1978: "PPP Predictor Compression Protocol".
- [55] IETF RFC 1662: "PPP in HDLC-like Framing".
- [56] ETSI ES 202 109: "Terrestrial Trunked Radio (TETRA); Security; Synchronization mechanism for end-to-end encryption".

---

## 3 Definitions and abbreviations

### 3.1 Definitions

For the purposes of the present document, the following terms and definitions apply:

**access code:** subdivision of mobiles for random access opportunities

**acknowledged data transfer:** service provided by the layer below which gives an acknowledgement back over the air interface from the lower layer peer entity

NOTE: This service is used by the layer 3 entities to get a secure transmission including retransmissions.

**advanced link:** bidirectional connection oriented path between one MS and a BS with provision of acknowledged and unacknowledged services, windowing, segmentation, extended error protection and choice among several throughputs

NOTE: The advance link requires a set-up phase.

**announced cell reselection:** cell reselection where MS-MLC informs the SwMI both in the old cell (leaving cell) and in the new cell (arriving cell) that cell change is performed

NOTE: There can be three types of announced cell reselection:

- type 1: the MS-MLE knows the new cell and the traffic channel allocations on the cell before deciding to leave its serving cell;
- type 2: the MS-MLE knows the new cell before changing to it, but does not know the channel allocation on the new cell in advance;
- type 3: the MS-MLE needs not to know the new cell before changing to it. The old cell is only informed by the MS-MLE that it wants to change cell.

TETRA V+D may support all three types of announced cell reselection.

**assigned channel:** channel allocated by the infrastructure to certain MSs using channel allocation command(s) addressed to those MSs

NOTE: An assigned channel may be allocated for secondary control purposes or for a circuit mode call.

**Associated Control Channel (ACCH):** dedicated signalling channel associated with a channel that has been assigned for circuit mode traffic

NOTE: It comprises the Fast Associated Control Channel (FACCH) which uses frames 1 to 18 when there is no traffic in a given direction or the Slow Associated Control Channel (SACCH) which is always available in frame 18 when there is traffic.

**attached:** MS is said to be attached to a cell when the MS is camped and registered on the cell

NOTE: The MS may be in idle mode (i.e. not actively processing a transaction) or in active mode (i.e. actively processing a transaction in reception and/or in transmission). It is the MM which decides when a MS is said to be attached.

**background measurement:** measurements performed by the lower layers while maintaining current service toward the service users, i.e. MS-MLE

**basic link:** bidirectional connectionless path between one or several MS and a BS, with a provision of both unacknowledged and acknowledged services on a single message basis

**Bit Error Ratio (BER):** limit ratio of the bits wrongly received to all bits received in a given logical channel

**broadcast:** unidirectional point to multi-point mode of transmission

**call-related service:** service requested from call set-up initiation until call disconnection and related to that call

NOTE: The call-related service can also be valid a certain short time after disconnection but before next call set-up is initiated.

**call unrelated service:** service either requested outside a call or inside a call but not referring to that call

**called user application:** user application which receives an incoming call

**calling user application:** user application which initiates an outgoing call

**camped:** MS is said to be camped on a cell when the MS is synchronized on the cell BS and has decoded the Broadcast Network Channel (BNCH) of the cell

NOTE: The synchronization procedure is performed by the MAC and the interpretation of the network information from the BNCH is performed by a procedure in the MLE. It is the MLE which decides when a MS is said to be camped on a cell.

**carrier specific signalling:** additional common signalling channel allocated in conjunction with a traffic channel specific to the carrier

**cell reselection:** act of changing the serving cell from an old cell to a new cell

NOTE: The cell reselection is performed by procedures located in the MLE and in the MAC. When the reselection is made and possible registration is performed, the MS is said to be attached to the cell.

**cell-id:** the channel number of the main carrier on the cell

NOTE: The cell-id as defined here has only a local validity. In TETRA context cell-id may also be another cell naming method used in a TETRA network to identify a specific cell independently of the channel number of the main carrier.

**common control channels:** control channels transmitted by the infrastructure to control the MS population

NOTE: The common control channels comprise the Main Control Channel (MCCH) and common Secondary Control Channels (SCCH).

**confirmed service:** service provided by the layer below which ensures that a message is responded to by the peer entity before new messages are allowed

NOTE: The service may be used for synchronization of peer entities or for provision of sequential behaviour.

**current serving BS:** BS on one of whose channels the MS is currently operating

**data/speech item:** all of the functions associated with a complete unidirectional transmission of information during a circuit mode call

NOTE: A call can be made up of one or more call transactions. In a half-duplex call these data/speech items are sequential and unidirectional on one user's point of view.

**direct set-up signalling:** signalling procedure where immediate communication can take place between the calling and the called users without the alerting process and without an explicit response from the called user that he has answered

**dummy call identity:** call identity used by MS or LS before the SwMI has allocated a valid call identity

NOTE: In TETRA the value of the dummy call identity is zero.

**duplex frequency spacing:** fixed frequency spacing between up and downlink frequencies directions

NOTE: The duplex spacing is defined in clause 6 and in TS 100 392-15 [49].

**foreground measurement:** measurements performed by the lower layers while employing the whole capacity, e.g. no concurrent service is maintained

**group home SwMI:** SwMI which owns the MCC and the MNC of the group identity

**Group TETRA Subscriber Identity (GTSI):** an identity used to set up and receive group calls and messages

NOTE: A TETRA user may have multiple GTSIs associated to its ITSI. Multiple users may have the same GTSI as a valid reception address.

**half duplex operation:** each MS asks for permission to transmit for each transaction

NOTE: In TETRA trunked mode operation half duplex means two-frequency simplex operation.

**Individual TETRA Subscriber Identity (ITSI):** identity used to specify an individual TETRA user

NOTE: An ITSI cannot be shared by multiple users.

**initial cell selection:** act of choosing a first serving cell to register in

NOTE: The initial cell selection is performed by procedures located in the MLE and in the MAC. When the cell selection is made and possible registration is performed, the MS is said to be attached to the cell.

**interrupted measurement:** measurements performed by the lower layers interrupting current services

**LLC frame:** generic name given to one LLC data message, regardless the type of link (basic or advanced) used

NOTE: An LLC frame comprises of a TL-SDU and LLC headers and a frame check sequence if applied. An LLC frame may be segmented for transmission.

**logical channel:** generic term for any distinct data path

NOTE: Logical channels are considered to operate between logical endpoints.

**MAC block:** unit of information transferred between the upper MAC and lower MAC for a particular logical channel

NOTE: Logical channels are e.g. SCH/F, SCH/HD or SCH/HU. The lower MAC performs channel coding for insertion into the appropriate physical slot, half slot or subslot.

**Main Control Channel (MCCH):** principal common control channel transmitted by the infrastructure to control the MSs in a cell

NOTE: The frequency of the main carrier for the cell is broadcast by the infrastructure, and the MCCH is located on timeslot 1 of the main carrier.

**Message Erasure Rate (MER):** limit ratio of the messages detected as wrong by the receiver to all messages received in a given logical channel

**message trunking:** traffic channel is permanently allocated for the complete duration of the call

NOTE: The call may include several separate call transactions (several pressel activations by separate terminals). The channel is only de-allocated if the call is (explicitly) released or if a time-out expires.

**minimum mode:** mode of operation in which the infrastructure allocates all four timeslots of the main carrier for traffic or assigned control purposes

NOTE: In this mode, only frame 18 can be used for common control without disturbing the established services.

**monitoring:** act of measuring the power of neighbour cells and calculate the path loss parameter C2 based upon information on neighbour cells broadcasted by the serving cell

**MS timing offset:** delay of the received signal relative to the expected signal from an MS at zero distance under static channel conditions

**normal mode:** mode of operation in which the MCCH is present in timeslot 1 of all frames 1 to 18

**on/off hook signalling:** signalling procedure which includes an alerting process to the called user

NOTE: An explicit response from the called user that he has answered is waited before the call can be set-up.

**piggy-backing:** method of sending a layer 3 message concatenated with a layer 2 acknowledgement in the same air interface transmission

**Probability Of Undetected Erroneous Message (PUEM):** limit ratio of the erroneous messages detected as right by the receiver to all messages received in a given logical channel

**protocol entity instance:** instance of a protocol entity refers to one independent process related to the protocol defined by that entity

NOTE: There may be multiple protocol entity instances e.g. circuit mode calls running simultaneously but independently from each other.

**quarter symbol number:** timing of quarter symbol duration 125/9  $\mu$ s within a timeslot

NOTE: In future releases of TETRA air interface standard the quarter symbol number may be valid only for features defined in the present document.

**quasi transmission trunking:** traffic channel is allocated for each call transaction (while the pressel is activated) and in addition the channel de-allocation is delayed for a short period at the end of the transaction (after the pressel release)

NOTE: During this "channel hang-time" the channel allocation may be re-used for a new call transaction that is part of the same call. A delayed channel de-allocation procedure applies at the end of each transaction.

**random access attempt:** period from the initiation of the random access procedure until the MS receives a response from the BS or abandons the procedure

NOTE: The random access is abandoned e.g. after sending the maximum permitted number of retries.

**ranking:** procedural method of listing cells in descending order from the most suitable for communication to the least suitable for communication

NOTE: As inputs to the ranking procedure are:

- outputs from the monitor process (e.g. C2 parameters);
- outputs from the scanning process (e.g. C1 parameters);
- network parameters received in the MLE broadcast.

**received SDU number:** received SDU number  $N(R)$  is the number of the received data TL-SDU

**received segment sequence number:** number of the currently received segment

**scanning:** act of measuring the power of neighbour cells and calculate the path loss parameter C1 based upon the information on the neighbour cells broadcasted by the neighbour cells themselves

**SDU number:** number on the advanced link to keep TL-SDUs in order

**Secondary Control Channel (SCCH):** control channel other than the MCCH and SCCH

NOTE: There are two types of SCCH:

- a common SCCH, which has the same functionality as the MCCH but is used only by a subset of the MS population; and
- an assigned SCCH, which may be allocated to certain MSs after an initial random access or paging message.

**segment:** LLC segment is the advanced link unit of transmission and re-transmission

NOTE: A segment is the numbered piece of a TL-SDU fitting into one MAC layer PDU (MAC block).

**sent SDU number (N(S)):** the number of the current TL-SDU

**sent segment sequence number (S(S)):** the number of the currently sent segment

**serving cell:** cell that is currently providing service to the MS

**simplex:** half-duplex operation

NOTE: Mainly used in TETRA standardization to differentiate half-duplex from (full) duplex communication.

**subscriber class:** a subdivision of the subscriber population

NOTE: The operator may define the values and meaning of each class.

**surveillance:** process of monitoring the quality of the radio link to the serving cell

**Time Division Multiple Access (TDMA) frame number:** timing of TDMA frames within a multiframe

**timebase:** device which determines the timing state of signals transmitted by a BS or MS

**timeslot number:** timing of timeslots within a TDMA frame

**TLA:** layer 2 SAP (TLA-SAP)

**TLB:** layer 2 SAP (TLB-SAP)

**TLC:** layer 2 SAP (TLC-SAP)

**TLC-SAP:** management Service Access Point (SAP)

NOTE: The TLC-SAP is a way of modelling layer-to-layer communication for management and control purpose.

**TL-SDU:** SDU from the service user (i.e. MLE)

**TM-SDU:** SDU from the layer above MAC (i.e. LLC)

**transmission trunking:** traffic channel is individually allocated for each call transaction (for each activation of the channel)

NOTE: The channel is immediately de-allocated at the end of the call transaction (subject to unavoidable protocol delays).

**unacknowledged data transfer:** service provided by the layer below which does not give any acknowledgement back to over the air interface from the lower layer peer entity

**unannounced cell reselection:** cell reselection where the MS-MLE does not inform the old cell (leaving cell) that it intends to change to a new cell

NOTE: Only the new cell (arriving cell) is informed about the cell reselection.

**unconfirmed service:** service provided by the layer below which does not ensure response from peer entities before allowing new messages

NOTE: This implies that messages to be transported may arrive in a different order at the peer entity since the sequence cannot be ensured.

**undeclared cell reselection:** cell reselection where the MS-MLE does not inform the old cell (leaving cell) nor the new cell (arriving cell) that cell change is performed

**useful part of a burst:** modulation symbol times SN0 to SNmax of a burst

NOTE: The useful part of the burst is defined in clause 9.

**visited SwMI:** SwMI which is broadcasting an MCC and/or MNC which is different than the MCC and MNC of the related TETRA identity

NOTE: This definition is for the purposes of the air interface. In the inter system interface standard EN 300 392-3-5 [31] the visited SwMI is referring to the data base actions and not directly to the MCC or MNC of the MS and SwMI.

## 3.2 Abbreviations

For the purposes of the present document, the following abbreviations apply:

AAA	Authentication, Authorization, Accounting
AACH	Access Assignment CHannel
ACCH	Associated Control CHannel
ACK	First Acknowledgement
ASSI	Alias Short Subscriber Identity
ATID	Address Type Identifier in Demand
BBK	Broadcast BloCk
BCC	Base station Colour Code
BCCH	Broadcast Control CHannel
BER	Bit Error Rate
BLCH	Base station Linearization CHannel
BN	Bit Number
BNCH	Broadcast Network CHannel
BS	Base Station
BSCH	Broadcast Synchronization CHannel
CB	Control uplink Burst
CC	Call Control
CCH	Control CHannel
CCK	Common Cipher Key
CHAP	Challenge Handshake Authentication Protocol
CLCH	Common Linearization CHannel
CMCE	Circuit Mode Control Entity
CoU	Class of Usage
CP	Control Physical channel
CPTI	Calling Party Type Identifier
CRC	Cyclic Redundancy Check
CSS	Carrier Specific Signalling
DCOMP	Data COMpression Protocol

D-CT	Downlink-Continuous Transmission
D-CTT	Downlink-Carrier Timesharing Transmission
DL	DownLink
DLL	Data Link Layer
D-MCCTT	Downlink Main Control Channel Timesharing Transmission
DMO	Direct Mode Operation
DQPSK	Differential Quaternary Phase Shift Keying
DTMF	Dual Tone Multiple Frequency
ECCH	Extended Control CHannel
FACCH	Fast Associated Control CHannel
FCS	Frame Check Sequence
FEC	Forward Error Correction
FN	Frame Number
FN	Frame Number
GIAT	Group Identity Address Type
GITI	Group Identify Type Identifier
GSSI	Group Short Subscriber Identity
GTSI	Group TETRA Subscriber Identity
HLR	Home Location Register
IMM	Immediate access parameter
IP	Internet Protocol
ISO	International Organization for Standardization
ISSI	Individual Short Subscriber Identity
ITSI	Individual TETRA Subscriber Identity
LA	Location Area
LB	Linearization Burst
LCH	Linearization CHannel
LCMC-SAP	Link entity Circuit Mode Control entity Service Access Point
LCP	Link Control Protocol
LLC	Logical Link control
LLME	Lower Layer Management Entity
LMM-SAP	Link entity Mobility Management-Service Access Point
LS	Line Station
LSB	Least Significant Bit
LTPD-SAP	Link entity TETRA Product Data - Service Access Point
MAC	Medium Access Control
MCC	Mobile Country Code
MCCH	Main Control CHannel
MCM	Minimum Control Mode
MER	Message Erasure Rate
MLE	Mobile Link Entity
MM	Mobility Management
MN	Multiframe Number
MN	Multiframe Number
MNC	Mobile Network Code
MNI	Mobile Network Identity
MO	Mobile station Originating
mod	modulo (base for counting)
MPN	Monitoring Pattern Number
MS	Mobile Station
MS-ISDN	Mobile Station-ISDN number
MST	Multiple Slot Transmission
MT	Mobile station Terminating
N(R)	Received SDU (TL-SDU) Number
N(S)	Sent SDU (TL-SDU) Number
NCM	Normal Control Mode
NDB	Normal Downlink Burst
NRA	National Regulatory Adminsitration
NSAPI	Network Service Access Point Identifier
NUB	Normal Uplink Burst
PACQ	Probability of synchronization burst acquisition
PAP	Password Authentication Protocol

PC	Protocol Control
PCOMP	Protocol COMpression Protocol
PDCH	Packet Data CHannel
PDF	Probability Density Function
PDP	Packet Data Protocol
PDS	Power Density Spectrum
PDU	Protocol Data Unit
PL	Physical Layer
PMR	Private Mobile Radio
PPP	Point-to-Point Protocol
PUEM	Probability of Undetected Erroneous Message
QN	Quarter symbol Number
QoS	Quality of Service
RA	Registered Area
RADIUS	Remote Authentication Dial In User Service
RCPC	Rate Compatible Punctured Convolutional
RF	Radio Frequency
RFC	Request For Comments
RM	Reed-Muller
RMS	Root Mean Square
S(R)	Received segment Sequence number
S(S)	Sent segment Sequence number
SACCH	Slow Associated Control CHannel
SAP	Service Access Point
SB	Synchronization downlink Burst
SCCH	Secondary Control CHannel
SCH	Signalling CHannel
SCLNS	Specific Connectionless Network Service
SD	Sample Duration
SDS	Short Data Service
SDTI	Short Date Type Identifier
SDU	Service Data Unit
SF	Slot Flag
SMI	Short Management Identity
SN	Symbol Number
SNA	Short Subscriber Identity
SNDCP	SubNetwork Dependent Convergence Protocol
SNEI	SNDCP Network Endpoint Identifier
SN-PDU	Symbol Number - Protocol Data Unit
SS	Supplementary Service
SSN	SubSlot Number
STCH	Stealing CHannel
SwMI	Switching and Management Infrastructure
TCH	Traffic CHannel
TDMA	Time Division Multiple Access
TE	Terminal Equipment
TIA	Type Identifier on Accept
TLP	TETRA Locator Protocol
TN	Timeslot Number
TNCC-SAP	TETRA Network layer Call Control-Service Access Point
TNSDS-SAP	TETRA Network layer Short Data Service-Service Access Point
TNSS-SAP	TETRA Network layer Supplementary Services Service Access Point
TP	Traffic Physical channel
TPTI	Transmitting party Type Identifier
TSI	TETRA Subscriber Identity
UL	UpLink
UP	Unallocated Physical channel
USSI	Unexchanged Short Subscriber Identity
WAP	Wireless Application Protocol
WT	Waiting Time



## 4 Radio aspects

### 4.1 Introduction

This clause is an introduction to the radio aspects of the TETRA V+D standard. It consists of a general description of the organization of the radio-related functions with reference to the clauses where each part is specified in details. Furthermore, it introduces the reference configuration that will be used throughout the present document.

### 4.2 Set of logical channels

The radio subsystem provides a certain number of logical channels as defined in clause 9. The logical channels represent the interface between the protocol and the radio.

### 4.3 Reference configuration

For the purpose of elaborating the specification of the radio-related functions, a reference configuration of the transmission chain is used as shown in figure 1.

NOTE: Only the transmission part is specified, the receiver being specified via overall performance requirements.

With reference to this configuration, the radio clauses address the following functional units:

- clause 5: differential encoding and modulation;
- clause 6: characteristics of transmitter and receiver;
- clause 8: coding, re-ordering and interleaving, and scrambling;
- clause 9: burst building and logical channel multiplexing.

This reference configuration also defines a number of points of vocabulary in relation to the names of bits at different levels in the configuration.

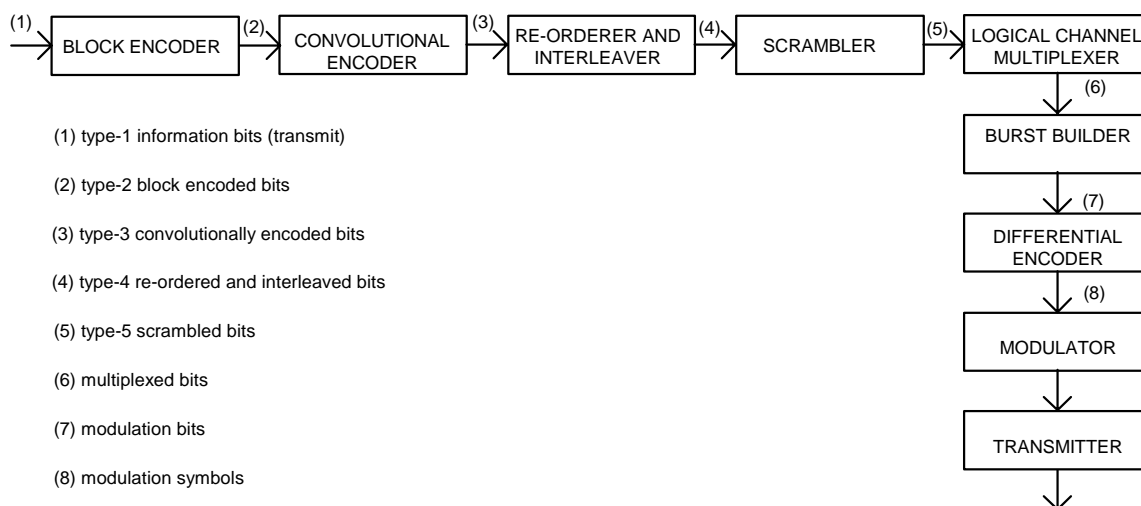


Figure 1: Reference configuration

### 4.4 Error control schemes

The different error control schemes are described in detail in clause 8.

## 4.5 Multiple access and time slot structure

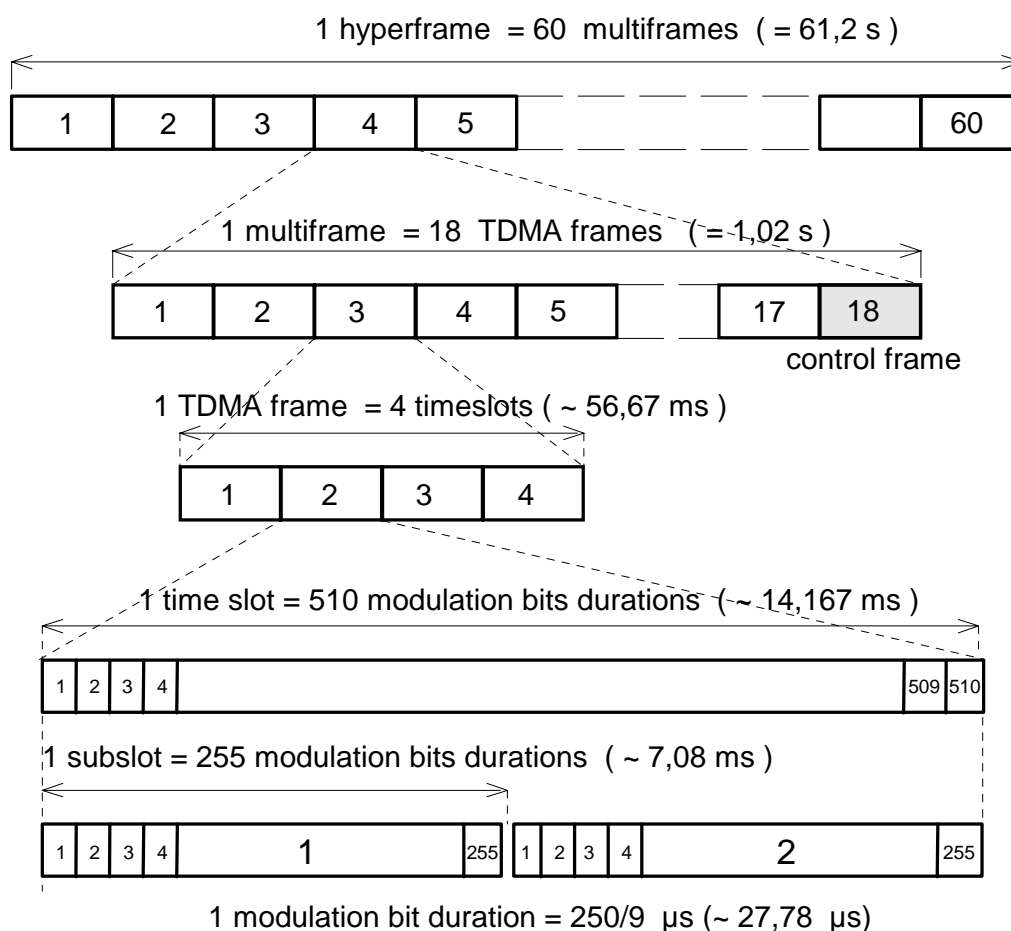
The access scheme is TDMA with 4 physical channels per carrier. The carrier separation is 25 kHz.

The basic radio resource is a timeslot lasting 14,167 ms ( $8\frac{5}{6}$  ms) transmitting information at a modulation rate of 36 kbit/s. This means that the time slot duration, including guard and ramping times, is 510 bit (255 symbol) durations.

The following clauses briefly introduces the structures of hyperframe, multiframe, frame, timeslot, and burst, as well as the mapping of the logical channels onto the physical channels. The appropriate specifications are found in clause 9.

### 4.5.1 Hyperframes, multiframes and frames

A diagrammatic representation of the TDMA structure is shown in figure 2.



**Figure 2: V+D TDMA structure**

The hyperframe level defines the top-level frame hierarchy. One hyperframe is subdivided into 60 multiframes, and lasts 61,2 s.

One multiframe is subdivided in 18 frames, and has a duration of 1,02 s. The eighteenth frame in a multiframe is a control frame.

One frame is subdivided into 4 time slots, and has a duration of  $170/3$  ms  $\approx 56,67$  ms.

### 4.5.2 Time slots and bursts

The time slot is a time interval of  $8\frac{5}{6}$  ms  $\approx 14,167$  ms, which corresponds to 255 symbol durations. The up-link timeslots may be subdivided into 2 subslots.

The physical contents of a time slot is carried by a burst. There are seven different types of bursts, as defined in clause 9.

### 4.5.3 Mapping of logical channels onto physical channels

Two types of physical channels are defined:

- the Traffic Physical channel (TP) carrying mainly traffic channels; and
- the Control Physical channel (CP) carrying exclusively the control channel. One CP channel is defined as the MCCH, the others are called Extended Control Channel (ECCH). The Radio Frequency (RF) carrier containing the MCCH is called the main carrier.

The mapping of the logical channels onto the physical channels, according to the mode of operation, is defined in clause 9.

## 4.6 Coding, interleaving and scrambling

The coding, interleaving and scrambling schemes associated with each logical channel shall be as specified in clause 8.

## 4.7 Modulation

The modulation scheme is  $\pi/4$ -shifted Differential Quaternary Phase Shift Keying ( $\pi/4$ -DQPSK) with root-raised cosine modulation filter and a roll-off factor of 0,35. The modulation rate is 36 kbit/s. This scheme is specified in detail in clause 5.

## 4.8 Transmission and reception

The modulated stream is transmitted on a RF carrier.

The specific RF channels, together with the requirements on the transmitter and the receiver characteristics are specified in clause 6.

For Base Stations (BSs) and MSs, power classes are defined in clause 6.

## 4.9 Other radio-related functions

Transmission involves other functions. These functions, which may necessitate the handling of specific protocols between BS and MS, are the radio subsystem synchronization, and the radio subsystem link control.

The synchronization incorporates:

- frequency and time acquisition by the receiver;
- adjustment of the timebase of the MSs.

The requirements on synchronization are specified in clause 7.

The radio link control adaptive power control:

- this function adjusts the RF transmit power, in order to ensure that the required quality of transmission is achieved with the least possible radiated power.

This function is managed by the MS during the initial access, and by the MS or BS during operational use.

This function is provided for battery saving and reduction of interference levels.

## 4.10 Performance

Under typical urban fading conditions (i.e. multipath delays no greater than 5  $\mu$ s), the quality threshold for full-rate speech is reached at a  $C/I_c$  (co-channel interference) value of 19 dB, and the dynamic reference sensitivity level is -106 dBm for BSs and -103 dBm for mobile equipment. Details of performance requirements in various channel conditions are given in clause 6.

## 4.11 TETRA modes of operation

The TETRA modes of operation which are supported by the present document and which impact on the radio descriptions are:

- transmission modes:
  - Downlink-Continuous Transmission (D-CT) mode:
    - the D-CT mode is mandatory for MSs, i.e. such equipment shall be able to interwork with a TETRA BS that would be in the D-CT mode.
  - Downlink-Carrier Timesharing Transmission (D-CTT) mode;
  - Downlink-Main Control Channel Timesharing Transmission (D-MCCTT) mode;
  - Multiple Slot Transmission (MST) mode.
- control modes:
  - Normal Control Mode (NCM):
    - the NC mode is mandatory for all TETRA equipment.
  - Minimum Control Mode (MCM):
    - the MC mode is mandatory only for the MSs.

In the following clauses, each of the above modes of operations are defined.

### 4.11.1 Transmission modes

#### 4.11.1.1 D-CT mode

In the D-CT mode, the BS always uses the continuous downlink bursts. The transmission is continuous on the main carrier. On the other carriers discontinuous transmission is allowed but is transparent for the MSs.

#### 4.11.1.2 D-CTT mode

In the D-CTT mode, a carrier frequency may be shared by several cells, each of its 4 physical channels being allocated independently to these cells. The BS uses the discontinuous downlink bursts.

#### 4.11.1.3 D-MCCTT mode

In the D-MCCTT mode, the MCCH is shared by several cells, each of its frames being allocated independently to these cells. The BS uses the discontinuous downlink burst.

#### 4.11.1.4 U-MST mode

In the MST mode, two to four physical channels are used for the same communication. This is used, for example, to increase the data transmission rate or to mix voice and data.

### 4.11.2 Control modes

#### 4.11.2.1 NCM

The NCM provides the TETRA services with full performance. It requires the assignment of one MCCH.

#### 4.11.2.2 MC mode

The MC mode provides the TETRA services with reduced performance. In the MC mode, all physical channels of each RF carrier should be devoted to traffic.

## 5 Modulation

### 5.1 Introduction

The following clauses apply to the baseband part of the transmitter.

### 5.2 Modulation type

The modulation used shall be  $\pi/4$ -shifted Differential Quaternary Phase Shift Keying ( $\pi/4$ -DQPSK).

### 5.3 Modulation rate

The modulation rate shall be 36 kbit/s.

### 5.4 Modulation symbol definition

$B(m)$  denotes the modulation bit of a sequence to be transmitted, where  $m$  is the bit number. The sequence of modulation bits shall be mapped onto a sequence of modulation symbols  $S(k)$ , where  $k$  is the corresponding symbol number.

The modulation symbol  $S(k)$  shall result from a differential encoding. This means that  $S(k)$  shall be obtained by applying a phase transition  $D\phi(k)$  to the previous modulation symbol  $S(k-1)$ , hence, in complex notation:

$$S(k) = S(k-1) \exp(jD\phi(k))$$

$$S(0) = 1 \tag{1}$$

The above expression for  $S(k)$  corresponds to the continuous transmission of modulation symbols carried by an arbitrary number of bursts. The symbol  $S(0)$  is the symbol before the first symbol of the first burst and shall be transmitted as a phase reference.

The phase transition  $D\phi(k)$  shall be related to the modulation bits as shown in table 1 and figure 3.

Table 1: Phase transitions

$B(2k-1)$	$B(2k)$	$D\phi(k)$
1	1	$-3\pi/4$
0	1	$+3\pi/4$
0	0	$+\pi/4$
1	0	$-\pi/4$

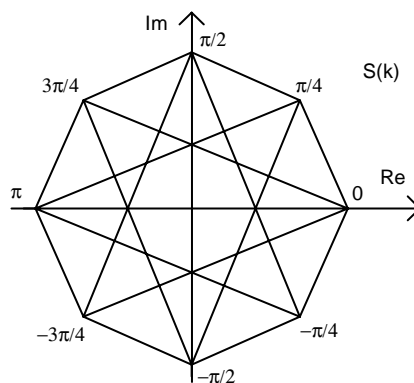


Figure 3: Modulation symbol constellation and possible transitions

The complex modulation symbol  $S(k)$  shall take one of the eight values  $\exp(j n \pi/4)$ , where  $n = 2, 4, 6, 8$  for even  $k$  and  $n = 1, 3, 5, 7$  for odd  $k$ . The constellation of the modulation symbols and the possible transitions between them are as shown in figure 3.

## 5.5 Modulated signal definition

The modulated signal, at carrier frequency  $f_c$ , shall be given by:

$$M(t) = \text{Re}\{s(t) \exp(j(2\pi f_c t + \phi_0))\} \quad (2)$$

Where:

- $\phi_0$  is an arbitrary phase;
- $s(t)$  is the complex envelope of the modulated signal defined as:

$$s(t) = \sum_{k=0}^K S(k)g(t - t_k) \quad (3)$$

Where:

- $K$  is the maximum number of symbols;
- $T$  is the symbol duration;
- $t_k = kT$  is the symbol time corresponding to modulation symbol  $S(k)$ ;
- $g(t)$  is the ideal symbol waveform, obtained by the inverse Fourier transform of a square root raised cosine spectrum  $G(f)$ , defined as follows:

$$G(f) = 1 \quad \text{for} \quad |f| \leq (1 - \alpha)/2T$$

$$G(f) = \sqrt{0.5(1 - \sin(\pi(2|f|T - 1)/2\alpha))} \quad \text{for} \quad (1 - \alpha)/2T \leq |f| \leq (1 + \alpha)/2T$$

$$G(f) = 0 \quad \text{for} \quad |f| \geq (1 + \alpha)/2T \quad (4)$$

Where  $\alpha$  is the roll-off factor, which determines the width of the transmission band at a given symbol rate. The value of  $\alpha$  shall be 0,35. For practical implementation, a time limited windowed version of  $g(t)$ , designed under the constraints given by the specified modulation accuracy and adjacent channel attenuation may be applied.

## 5.6 Modulation filter definition

The ideal modulation filter shall be a linear phase filter which is defined by the magnitude of its frequency response  $|H(f)| = G(f)$ .

## 5.7 Modulation block diagram

A block diagram of the modulation process is shown on figure 4. This diagram is for explanatory purposes and does not prescribe a specific implementation. The modulation filter excited by the complex Dirac impulse function  $S(k)\delta(t-t_k)$  ideally has an impulse response  $g(t)$ .

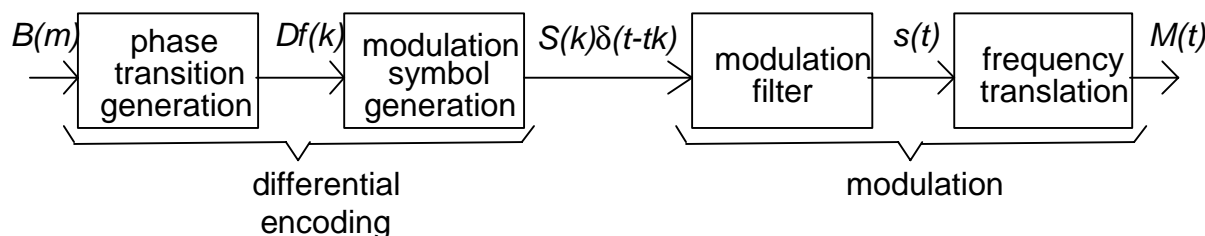


Figure 4: Block diagram of the modulation process

# 6 Radio transmission and reception

## 6.1 Introduction

This clause defines the requirements for the MS and the BS transceiver of the TETRA V+D system. This clause is applicable to TETRA systems operating at radio frequencies of 300 MHz to 1 GHz.

NOTE: The values specified in this clause are based on calculations, simulations, or existing standards. It is, therefore, essential that these values are confirmed during the validation phase. The values for the carrier number are defined in clause 21.

## 6.2 Frequency bands and channel arrangement

When used in dedicated TETRA frequency bands, TETRA MSs shall transmit in the TETRA uplink frequency band, and TETRA BSs shall transmit in the TETRA downlink frequency band. The uplink and downlink frequency bands are of equal width. Their edges shall be as follows:

- $F_{up, min} - F_{up, max}$  (MHz): mobile transmit, base receive;
- $F_{dw, min} - F_{dw, max}$  (MHz): base transmit, mobile receive.

The TETRA RF carrier separation shall be 25 kHz. In order to ensure compliance with the radio regulations outside the band, a guard band may be needed at each side of both uplink and downlink bands.

The centre frequencies of downlink RF carriers,  $F_{down,c}$  shall be given by the value of downlink carrier frequency defined in clause 21, the corresponding centre frequency of uplink RF carriers,  $F_{up,c}$ , shall be given by:

$$F_{up,c} = F_{down,c} - D \quad (6)$$

When a TETRA system is operated in frequency bands used for analogue Private Mobile Radio (PMR), the uplink and downlink transmit and receive centre frequencies and the duplex spacing ( $D$ ) will be allocated by the National Regulatory Administration (NRA).

In all frequency bands, the TETRA stations shall use a fixed duplex spacing  $D$ .

## 6.3 Reference test planes

For the purposes of testing, all TETRA stations shall have at least one antenna connector as specified by the manufacturer.

The base station equipment may include, at the discretion of the manufacturer, some or all of the optional items shown in figure 5 if they are necessary to meet the requirements of the present document, with the antenna connection(s) at Points 1T, 1R or 2. The equipment must comply with the present document at the antenna connector(s) specified.

In the case of equipment comprising several transmitters, only one transmitter shall be transmitting during all measurements, except for measuring intermodulation attenuation.

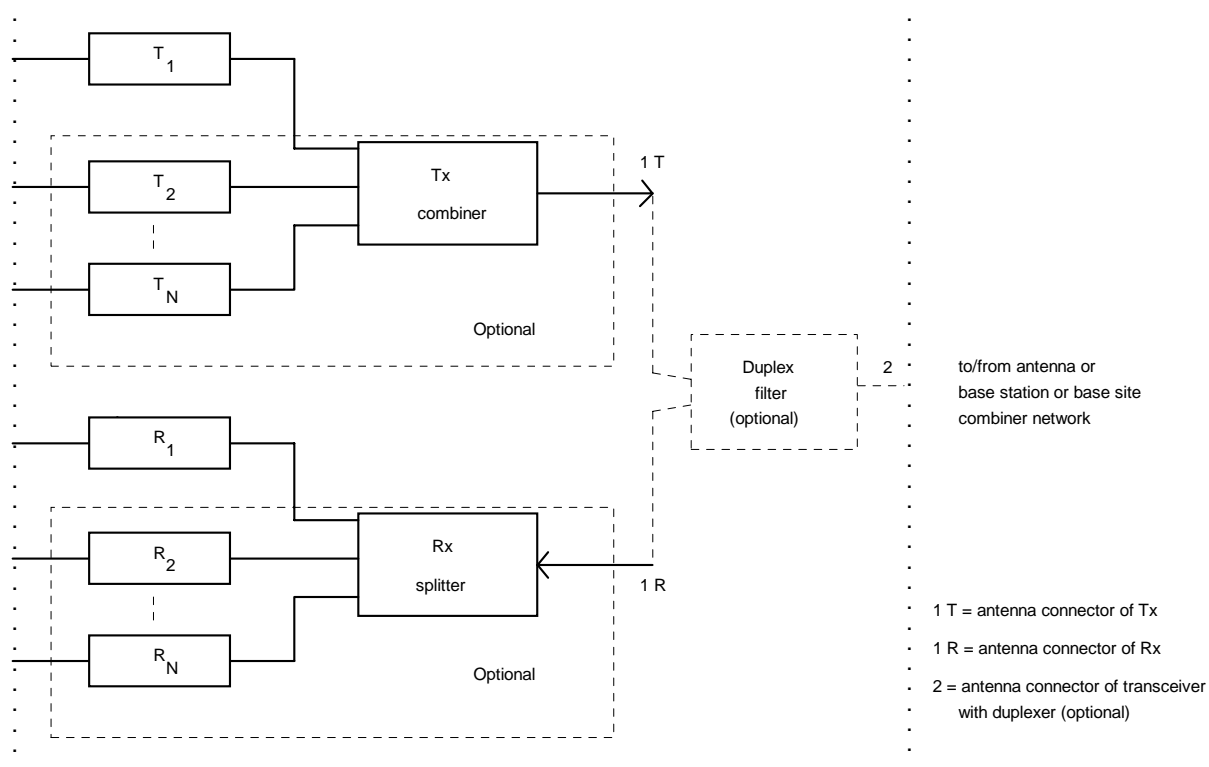


Figure 5: Reference interconnection of transmitters and receivers at BS

## 6.4 Transmitter characteristics

### 6.4.1 Output power

In the following clauses, power is defined as the average power, measured through the square root raised cosine filter defined in clause 5 over the useful part of the burst as defined in clause 9.

The power at which MSs or BSs may operate are specified in the following clauses.



### 6.4.1.1 Base Station (BS)

The BS transmitter nominal power shall be as defined in table 2 according to its power class.

**Table 2: Nominal power of BS transmitters**

Power class	Nominal power per carrier
1 (40 W)	46 dBm
2 (25 W)	44 dBm
3 (15 W)	42 dBm
4 (10 W)	40 dBm
5 (6,3 W)	38 dBm
6 (4 W)	36 dBm
7 (2,5 W)	34 dBm
8 (1,6 W)	32 dBm
9 (1 W)	30 dBm
10 (0,6 W)	28 dBm

### 6.4.1.2 Mobile Station (MS)

The MS nominal power shall be as defined in table 3 according to its power class.

**Table 3: Nominal power of MS transmitters**

Power class	Nominal power
1 (30 W)	45 dBm
1L ( 17,5 W)	42,5 dBm
2 (10 W)	40 dBm
2L (5,6 W)	37,5 dBm
3 (3 W)	35 dBm
3L (1,8 W)	32,5 dBm
4 (1 W)	30 dBm
4L (0,56 W)	27,5 dBm

The different power levels needed for adaptive power control (see clause 10) shall have the values as defined in table 4, starting from the minimum power control level of 15 dBm (step level 7) up to the nominal power level corresponding to the class of the particular MS as stated in table 3.

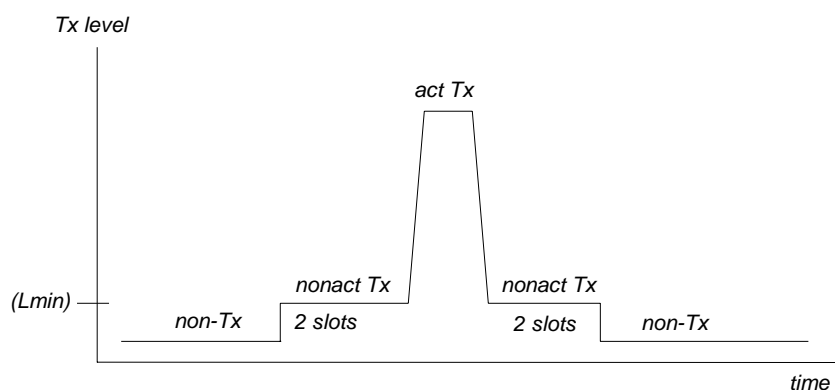
**Table 4: Nominal MS power control levels**

Step level	Power
1	45 dBm
2	40 dBm
3	35 dBm
4	30 dBm
5	25 dBm
6	20 dBm
7	15 dBm

## 6.4.2 Unwanted conducted emissions

### 6.4.2.1 Definitions

Unwanted emissions are defined as conducted emissions at frequencies or time intervals outside the allocated channel. The specified limits shall be met under realistic conditions, for instance under varying antenna mismatch. Unless otherwise stated, unwanted emissions are specified for an equipment in the active transmit (act Tx) state, i.e. whenever this equipment transmits bursts, or whenever it ramps-up/linearizes or ramps-down. The non-active transmit (nonact Tx) state is a state occurring during two timeslot durations (approximately 28 ms) before and after any active transmit state.



**Figure 6: Schematic presentation of transmitter states**

An equipment is said to be in the non-transmit (non-Tx) state whenever it is not in the active or non-active transmit state (refer to figure 6).

#### 6.4.2.2 Unwanted emissions close to the carrier

The emissions in the following clauses shall be measured through the square root raised cosine filter with a roll-off factor of 0,35, as defined in clause 5.

Measurements shall be done at the nominal centre frequency and at the frequency offsets specified in table 5. When applicable, relative measurements (dBc) shall refer to the level measured at the nominal centre frequency.

##### 6.4.2.2.1 Emission during the useful part of the burst

The levels given in tables 5a and 5b shall not be exceeded at the listed frequency offsets from the nominal carrier frequency.

**Table 5a: Maximum adjacent power levels for frequencies below 700 MHz**

Frequency offset	Maximum level for MS power classes 4 and 4L	Maximum level for other power classes
25 kHz	-55 dBc	-60 dBc
50 kHz	-70 dBc	-70 dBc
75 kHz	-70 dBc	-70 dBc

In any case, no requirement in excess of -36 dBm shall apply.

**Table 5b: Maximum adjacent power levels for frequencies above 700 MHz**

Frequency offset	Maximum level
25 kHz	-55 dBc
50 kHz	-65 dBc
75 kHz	-65 dBc (see note)
NOTE: A level of -70 dBc shall apply for BS Power Classes 1, 2 and 3 and for MS Power Classes 1 and 1L.	

In any case, no requirement in excess of -36 dBm shall apply.

The specifications assume that the centre frequency is at the above listed frequency offsets from the nominal carrier frequency. The measured values shall be averaged over the useful part of the burst (see clause 9). The scrambled bits shall have a pseudo-random distribution from burst to burst.

### 6.4.2.2 Emission during the switching transients

At the frequency offset from the nominal carrier frequency given below, peak power measurements shall be done, covering at least the ramp-up period and the ramp-down period (figure 7, periods  $t_1$  and  $t_3$ ) (see clause 6.4.5 for definition of  $t_1$  and  $t_3$ ).

The maximum hold level of -45 dBc for MS Power Classes 4 and 4L and -50 dBc for other Power Classes at a frequency offset of 25 kHz shall not be exceeded. This requirement does not apply to linearization channels.

In any case no requirement in excess of -36 dBm shall apply.

### 6.4.2.3 Unwanted emissions far from the carrier

These unwanted emissions are emissions (discrete, wideband noise, modulated or un-modulated) occurring at offsets of equal to, or greater than, 100 kHz from the carrier frequency, measured in the frequency range 9 kHz to 4 GHz.

a) Discrete spurious:

- the maximum allowed power for each spurious emission shall be less than -36 dBm measured in 100 kHz bandwidth in the frequency range 9 kHz to 1 GHz and -30 dBm measured in 1 MHz bandwidth in the frequency range 1 GHz to 4 GHz (1 GHz to 12,75 GHz for equipment capable of operating at frequencies above 470 MHz). Specific measurement methods are required both when measuring within  $\pm f_{rb}$  of carrier frequency, due to the presence of wideband noise, and in the lower part of the spectrum.

b) Wideband noise:

- the wideband noise levels, measured through the modulation filter defined in clause 5.6 should not exceed the limits shown in tables 6a and 6b, for the nominal power levels as stated, and at the listed offsets from the nominal carrier frequency. The requirements apply symmetrically to both sides of the transmitter band.

**Table 6a: Wideband noise limits for frequencies below 700 MHz**

Frequency offset	Maximum wideband noise level		
	MS nominal power level $\leq 1$ W (class 4)	MS nominal power level = 1,8 W or 3 W (class 3L or 3)	MS nominal power level $\geq 5,6$ W (class 2L) BS all classes
100 kHz to 250 kHz	-75 dBc	-78 dBc	-80 dBc
250 kHz to 500 kHz	-80 dBc	-83 dBc	-85 dBc
500 kHz - $f_{rb}$	-80 dBc	-85 dBc	-90 dBc
$> f_{rb}$	-100 dBc	-100 dBc	-100 dBc
NOTE: $f_{rb}$ denotes the frequency offset corresponding to the near edge of the receive band or 5 MHz (10 MHz for frequencies above 520 MHz) whichever is greater.			

**Table 6b: Wideband noise limits for frequencies above 700 MHz**

Frequency offset	Maximum wideband noise level		
	MS nominal power level $\leq 1$ W (class 4)	MS nominal power levels from 1,8 W to 10 W and BS Nominal power levels $\leq 10$ W	MS and BS nominal power levels from 15 W to 40 W
100 kHz to 250 kHz	-74 dBc	-74 dBc	-80 dBc
250 kHz to 500 kHz	-80 dBc	-80 dBc	-85 dBc
500 kHz - $f_{rb}$	-80 dBc	-85 dBc	-90 dBc
$> f_{rb}$	-100 dBc	-100 dBc	-100 dBc
NOTE: $f_{rb}$ denotes the frequency offset corresponding to the near edge of the received band or 10 MHz whichever is greater.			

All levels in tables 6a and 6b are expressed in dBc relative to the actual transmitted power level, and in any case no limit tighter than -55 dBm for offsets  $< f_{rb}$  or -70 dBm for offsets  $> f_{rb}$  shall apply.

#### 6.4.2.4 Unwanted emissions during the CLCH and BLCH

The following emissions shall be measured through a square root raised cosine filter with a roll-off factor of 0,35 as defined in clause 5.

The sum of the time periods during which the peak power, at a frequency offset of  $\pm 25$  kHz during the BLCH/CLCH, is above -45 dBc shall not exceed 1ms. This peak power shall never exceed -30 dBc.

NOTE: 0 dBc refers to the transmit power during normal operation after the CLCH or BLCH.

#### 6.4.2.5 Unwanted emissions in the non-transmit state

The specifications of clause 6.5.4.2 apply.

### 6.4.3 Unwanted radiated emissions

Unwanted radiated emissions are emissions (whether modulated or un-modulated) radiated by the cabinet and structure of the equipment (MS or BS). This is also known as cabinet radiation.

The limits given in clause 6.4.2.3 shall apply for frequencies between 30 MHz and 4 GHz only.

### 6.4.4 RF tolerance

The RF tolerance for BSs and MSs is defined in clause 7.

### 6.4.5 RF Output power time mask

The transmit level versus time mask for TETRA station transmission is shown in figure 7. For the time mask the power level of 0 dBc refers to the output power level of the TETRA station under consideration.

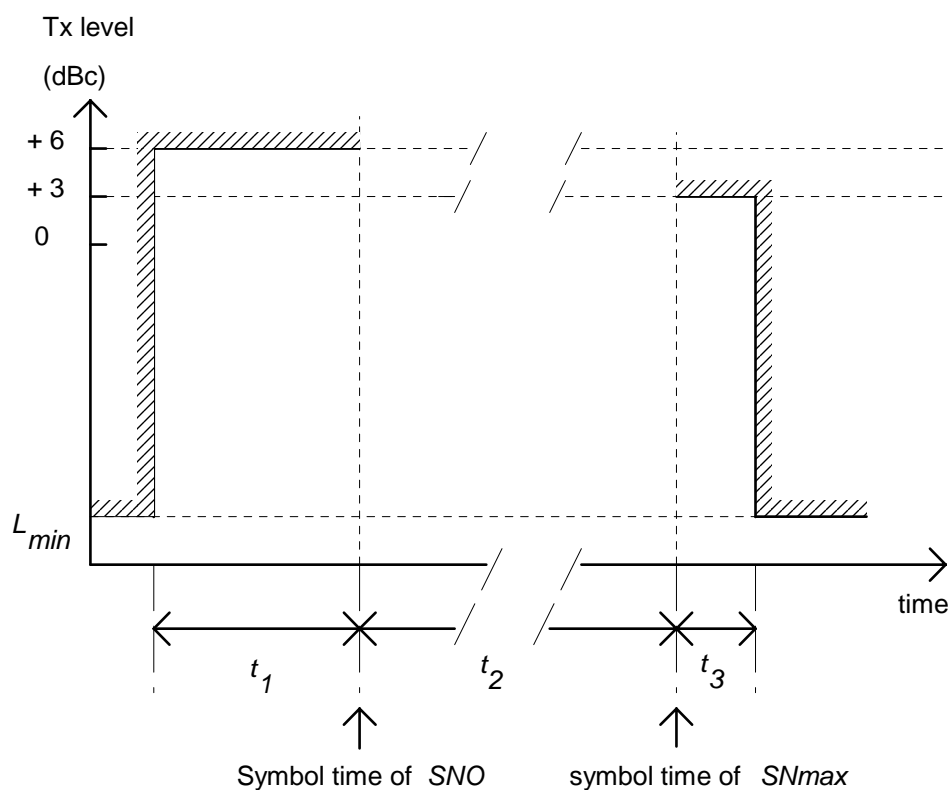


Figure 7: Transmit level versus time mask

**Table 7: Transmit level versus time mask symbol durations (re figure 7)**

Burst Type	$t_1$	$t_2$	$t_3$
Control uplink	16	103	15
Linearization uplink	119	0	15
Linearization downlink	107	0	0
Normal uplink	16	231 (see note)	15
Discontinuous downlink	7	246 (see note)	7
Continuous downlink	Unspecified	Unspecified	Unspecified
NOTE: In the case of single slot transmission.			

Whenever bursts are consecutively transmitted by the same TETRA station on the same frequency, the transmit level versus time mask applies at the beginning of the transmission of the first burst and at the end of the transmission of the last burst.

The symbol numbers referred to as  $SNO$  and  $SNmax$  are defined in clause 9. The timing of the transmitted bursts is specified in clause 7. The time periods  $t_1$ ,  $t_2$  and  $t_3$ , whose durations are stated in table 7, are defined in the following way:

- the time  $t_1$  starts at the beginning of the ramp-up of the first burst, and expires just before the symbol time of  $SNO$ ;
- the time  $t_2$  starts at the symbol time of  $SNO$  of the first burst and finishes at the symbol time of  $SNmax$  of the last burst;
- the time  $t_3$  starts just after the symbol time of  $SNmax$  of the last burst and finishes at the end of the ramp-down.

In this clause, the specifications of clauses 6.4.1 and 6.6.1 shall apply during the time  $t_2$ . The output power shall be measured through the square root raised cosine filter with a roll off factor of 0,35 as defined in clause 5.

#### 6.4.5.1 BS

The BS output power shall be at the nominal level, as specified in clause 6.4.1.1. Power control shall not be applied to the downlink transmissions.

In the non-active transmit state the specification  $L_{min} = -40$  dBc shall apply.

The peak transmit power during BLCH shall not exceed +6 dBc.

#### 6.4.5.2 MS

The MS output power shall be able to be reduced to levels defined in table 4, down to a minimum level of 15 dBm. The power levels that can be achieved, according to the class of the MS, are detailed in clause 6.4.1.2.

During the non-active transmit state the specification  $L_{min} = -70$  dBc or  $L_{min} = -36$  dBm, whichever is greater, shall apply.

### 6.4.6 Transmitter intermodulation attenuation

#### 6.4.6.1 Definition

The intermodulation attenuation is the ratio of the power level of the wanted signal to the power level of an intermodulation component. It is a measure of the capability of the transmitter to inhibit the generation of signals in its non-linear elements caused by the presence of the useful carrier and an interfering signal reaching the transmitter via its antenna.

### 6.4.6.2 BS

The intermodulation attenuation of the BS equipment shall be at least 70 dB for any intermodulation component when measured in a 30 kHz bandwidth. The interfering signal shall be unmodulated and have a frequency offset of at least 500 kHz from the carrier frequency. The power level of the interfering signal shall be 30 dB below the power level of the modulated output signal from the transmitter under test. If the intermodulation attenuation is achieved by additional, internal or external, isolating devices they shall be included in the measurements.

However, in the case of BS equipment with only one transmitter and which is not intended to be collocated with other radio equipment operating in the same frequency band, an intermodulation attenuation of at least 40 dB shall be sufficient.

In any case no requirement more stringent than -36 dBm shall apply to intermodulation components.

All power levels stated in the cases above refer to the antenna connector of the BS described in clause 6.3.

### 6.4.6.3 MS

In an MS, intermodulation may be caused when operating transmitters in the close vicinity of each other.

For an MS transmitter operating at the nominal power defined by its class, the intermodulation attenuation shall be at least 60 dB for any intermodulation component when measured in 30 kHz bandwidth. The interfering signal shall be unmodulated and have a frequency offset of at least 500 kHz from the carrier frequency. The power level of the interfering signal shall be 50 dB below the power level of the modulated output signal from the transmitter under test.

## 6.4.7 Intra-BS intermodulation requirements

In a BS, intermodulation may be caused by combining several transmitters and carriers to feed a single antenna.

For all transmitters of a single TETRA BS, the power of any intermodulation components, when measured in a 30 kHz bandwidth, shall not exceed -60 dBc in the relevant downlink frequency band. In any case no requirement in excess of -36 dBm shall apply.

NOTE: The value of -60 dBc refers to the carrier power of the transmitter with the highest output power measured at the antenna connector of the BS described in clause 6.3.

In the case where the performance is achieved by additional internal or external isolating devices (such as circulators) they shall be supplied at the time of conformance testing and shall be used for measurements.

## 6.5 Receiver characteristics

In this clause, the levels of the test signals are given in terms of power levels (dBm) at the antenna connector of the receiver. For the definition of power level refer to clause 6.4.1.

Sources of test signals shall be connected in such a way that the impedance presented to the receiver input is a 50  $\Omega$  non-reactive impedance.

This requirement shall be met irrespective of whether one or more signals using a combining network are applied to the receiver simultaneously.

Static propagation conditions are assumed in all cases, for both wanted and unwanted signals.

### 6.5.1 Blocking characteristics

#### 6.5.1.1 Definition

Blocking is a measure of the capability of the receiver to receive a modulated wanted input signal in the presence of an unwanted unmodulated input signal on frequencies other than those of the spurious responses or the adjacent channels, without this unwanted input signal causing a degradation of the performance of the receiver beyond a specified limit.

### 6.5.1.2 Specification

The blocking performance specification given in table 8 shall apply at all frequencies except those at which spurious responses occur (see clause 6.5.2).

**Table 8: Blocking levels of the receiver**

Offset from nominal Rx freq.	Level of interfering signal
50 kHz to 100 kHz	-40 dBm
100 kHz to 200 kHz	-35 dBm
200 kHz to 500 kHz	-30 dBm
> 500 kHz	-25 dBm

The static reference sensitivity performance as specified in clause 6.6.2.4 shall be met when the following signals are simultaneously input to the receiver:

- a wanted signal at the nominal receive frequency  $f_o$ , 3 dB above the static reference sensitivity level as specified in clause 6.6.2.4;
- a continuous sine wave signal at a frequency offset from  $f_o$  and level as defined in table 8.

## 6.5.2 Spurious response rejection

### 6.5.2.1 Definition

Spurious response rejection is a measure of the capability of a receiver to receive a wanted modulated signal without exceeding a given degradation due to the presence of an unwanted un-modulated signal at any other frequency at which a response is obtained, i.e. for which the blocking limit is not met.

### 6.5.2.2 Specification

- The static reference sensitivity performance as specified in clause 6.6.2.4 shall be met when the following signals are simultaneously applied to the receiver:
  - a wanted signal at nominal receive frequency  $f_o$ , 3 dB above the static reference sensitivity level as specified in clause 6.6.2.4;
  - a continuous sine wave signal with any offset from nominal Rx frequency  $\geq 50$  kHz at a level of -45 dBm.
- The number of frequencies within a limited frequency range, defined below, at which the blocking specification of clause 6.5.1.2 is not met shall not exceed 0,05 x (number of frequency channels in the limited frequency range).

The limited frequency range is defined as the frequency of the local oscillator signal  $f_{lo}$  applied to the first mixer of the receiver plus or minus the sum of the intermediate frequencies ( $f_{i1}, \dots, f_{in}$ ) and a half of the switching range ( $sr$ ) of the receiver.

Hence the frequency  $f_l$  of the limited frequency range is:

$$f_{lo} - \sum_{j=1}^n f_{ij} - \frac{sr}{2} \leq f_l \leq f_{lo} + \sum_{j=1}^n f_{ij} + \frac{sr}{2} \quad (7)$$

Where receiver switching range ( $sr$ ) is the maximum frequency range over which the receiver can be operated without reprogramming or realignment as declared by the manufacturer.

## 6.5.3 Intermodulation response rejection

### 6.5.3.1 Definition

Intermodulation response rejection is a measure of the capability of the receiver to receive a wanted modulated signal without exceeding a given degradation due to the presence of two or more unwanted signals with a specific frequency relationship to the wanted signal frequency as defined in EN 300 113-1 [8].

### 6.5.3.2 Specification

The static reference sensitivity performance as specified in clause 6.6.2.4 shall be met when the following signals are simultaneously input to the receiver:

- a wanted signal at the nominal receive frequency  $f_o$ , 3 dB above the static reference sensitivity level;
- a continuous sine wave signal at frequency  $f_1$  and with a level of -47 dBm;
- a pseudo-random sequence TETRA modulating a signal at frequency  $f_2$ , with a level of -47 dBm, such that  $f_o = 2 f_1 - f_2$  and  $|f_2 - f_1| = 200$  kHz.

## 6.5.4 Unwanted conducted emissions

### 6.5.4.1 Definition

Unwanted emissions from the equipment when in reception are defined as conducted emissions at any frequency, when the equipment is in the non-transmit state.

### 6.5.4.2 Specification

The peak power emitted by the equipment shall not exceed -57 dBm at frequencies between 9 kHz and 1 GHz, as measured in a bandwidth of 100 kHz.

For equipment only capable of operating below 470 MHz the power emitted by the equipment shall not exceed -47 dBm from 1 GHz to 4 GHz, as measured in a bandwidth of 1 MHz.

For equipment capable of operating above 470 MHz the power emitted by the equipment shall not exceed -47 dBm from 1 GHz to 12,75 GHz, as measured in a bandwidth of 1 MHz.

## 6.5.5 Unwanted radiated emissions

Unwanted radiated emissions are emissions radiated by the cabinet and structure of the equipment (MS or BS) in the non-TX state. This is also known as cabinet radiation.

The limits given in clause 6.5.4.2 shall apply for frequencies between 30 MHz and 4 GHz only.

## 6.6 Transmitter/receiver performance

Clause 6.6.1 specifies the modulation accuracy requirement, by setting limits on the Root Mean Square (RMS) error between the actual transmitted signal waveform and the ideal signal waveform. Clause 6.6.2 specifies the receiver performance, assuming that transmit errors do not occur. Clause 6.6.3 specifies all the propagation models that are defined in the present document.



## 6.6.1 Modulation accuracy

The specified requirement is vector error magnitude; this does not only take into account modulation filtering linear distortion (amplitude and phase) or modulator impairments (quadrature offset, phase and linear amplitude errors in the modulation symbol constellation) but is a measure of the whole transmitter quality. It also takes into account local oscillator phase noise, filter distortion, and non-linearity of amplifiers. Vector error magnitude shall be specified at symbol time (see clause 6.6.1.2) and the vector error magnitude requirement shall be fulfilled by the TETRA equipment with maximum and with minimum power levels (as defined in clause 6.4.1).

### 6.6.1.1 Ideal case

The modulation symbol  $s(t)$  transmitted by an ideal transmitter having a filter impulse response  $g(t)$  is defined in clause 5.

$$g^*(-t)|_{t=t_k}$$

Let  $Z(k)$  denote the output of an ideal receive filter with impulse response  $g^*(-t)|_{t=t_k}$ . The ideal transmit and receive filters in cascade form a raised cosine Nyquist filter, having a symbol waveform going through zero at symbol duration intervals, so there is no inter-symbol interference at any instant  $t = t_k$ , where  $t_k$  is the symbol time corresponding to the  $k$ -th symbol (as defined in clause 5).

In this case, the output of an ideal receive filter at any instant  $t_k$ , stimulated by an ideal transmitter, will be equal to the  $k$ -th modulation symbol  $S(k)$ :

$$Z(k) = s(t) * g^*(-t)|_{t=t_k} = S(k) \quad (8)$$

In this clause, the numbering of the modulation symbols used is the one defined in clause 9.

### 6.6.1.2 Vector error magnitude requirement at symbol time

Let  $Z(k)$  be the output produced by observing the real transmitter through the ideal receive filter at symbol time  $t_k$ .  $Z(k)$  is modelled as:

$$Z(k) = \{C_0 + [S(k) + E(k)]\} C_1 W(k) \quad (9)$$

Where:

- $E(k)$  is the vector error of modulation symbol  $S(k)$ ;
- $W(k) = \exp(jk\Theta)$  accounts for a frequency offset giving  $\Theta$  radians per symbol phase rotation due to transmitter frequency inaccuracy (see clause 7). The possible amplitude variations shall be integrated in the vector error;
- $C_0$  is a complex constant characterizing the residual carrier;
- $C_1$  is a complex constant representing the output amplitude and initial phase of the transmitter.

The magnitude of  $C_0$  shall be less than 5 % of the magnitude of  $S(k)$ . The task of the test receiver is then to:

- estimate the symbol time for processing the receive part;
- estimate the values of  $C_0$ ,  $C_1$  and  $\Theta$ . The resulting estimates shall be denoted by  $C_0'$ ,  $C_1'$  and  $\Theta'$  respectively;
- perform a normalization of the modulation symbol  $Z(k)$  accordingly. The modulation symbol that results from this normalization shall be denoted by  $Z'(k)$ :

$$Z'(k) = \left[ Z(k) \exp(-jk\Theta') / C_1' \right] - C_0' \quad (10)$$

With the above notations, the Sum Square Vector Error (SSVE) is defined as:

$$SSVE = \sum_{k=1}^{SNmax} |Z'(k) - S(k)|^2 \quad (11)$$

Where  $SNmax$  is the number of symbols in the burst.

The RMS vector error is then computed as the square root of the sum-square vector error divided by the number of symbols in the burst:

$$RMSVE = \sqrt{SSVE / SNmax} \quad (12)$$

The RMS vector error in any burst shall be less than 0,1.

The peak vector error magnitude  $|Z'(k)-S(k)|$  shall be less than 0,3 for any symbol.

## 6.6.2 Receiver performance

This clause specifies the minimum required receiver performance in terms of Bit Error Ratio (BER), Message Erasure Rate (MER) or Probability of Undetected Erroneous Message (PUEM) (whichever is appropriate), taking into account that transmitter errors do not occur, and that the transmitter shall be tested separately (see clause 6.6.1).

In this clause, the levels of the test signals are given in terms of power levels (dBm) at the antenna connector of the receiver. For the definition of power level refer to clause 6.4.1.

Three equipment classes are specified, distinguishing their intended operating environments and testing conditions. The classes have preferred operating conditions, as follows:

- **Class B:** equipment is optimized for use in built-up and urban areas. The present document guarantees good performance at the reference sensitivity and interference level in static and TU50 conditions, but not in extreme propagation conditions (hilly terrain);
- **Class A:** equipment is optimized for use in urban areas and in areas with hilly or mountainous terrain. It is resilient to extreme propagation conditions (hilly terrain) and is specified in static, TU50 and HT200 conditions;
- **Class E:** equipment comprises an equalizer and is specified in static, TU50, HT200 (PACQ only) and EQ200 conditions. It is not applicable to BS equipment.

### 6.6.2.1 Nominal error rates

This clause describes the transmission requirements in terms of error ratios in nominal conditions i.e. without interference and with an input level of -85 dBm. The relevant propagation conditions are given in clause 6.6.3.

Under the following propagation conditions, the BER of the non-protected bits, equivalent to the TCH/7,2 shall have the limits given in table 9.

**Table 9: Nominal error rates**

Propagation model	BER	Equipment class
STATIC	0,01 %	A, B, E
TU50	0,40 %	A, B, E
HT200	3,00 %	A
EQ200	2,00 %	E

This performance shall be maintained up to -40 dBm input level for the static conditions, and multipath conditions. Furthermore, for static conditions, a BER of < 0,1 % shall be maintained up to -20 dBm.

### 6.6.2.2 Dynamic reference sensitivity performance

The minimum required dynamic reference sensitivity performance is specified according to the logical channel, the propagation condition and the receiver class at the dynamic reference sensitivity level. The dynamic reference sensitivity level shall be:

- for MS: -103 dBm;
- for BS: -106 dBm.

Tables 10 and 11 give the maximum permissible receiver MER or BER at dynamic reference sensitivity performance for TU50, HT200 or EQ200 propagation conditions. For BSCH, SCH/HD, SCH/HU, SCH/F and BNCH, a PUEM < 0,001 % shall be achieved at the dynamic reference sensitivity level. For AACH, a PUEM < 0,01 % shall be achieved at the dynamic reference sensitivity level.

#### 6.6.2.2.1 BS receiver performance

**Table 10: Maximum permissible BS receiver MER or BER at dynamic reference sensitivity level**

Logical channel	Error count type	Class A		Class B
		Propagation condition		Propagation condition
		TU50	HT200	TU50
SCH/HU	MER	8 %	9.5 %	8 %
SCH/F	MER	11 %	11 %	8 %
TCH/7,2	BER	2,5 %	4 %	2,2 %
TCH/4,8 N = 1	BER	4 %	4 %	2 %
TCH/4,8 N = 4	BER	1,2 %	4 %	0,4 %
TCH/4,8 N = 8	BER	0,4 %	4 %	0,06 %
TCH/2,4 N = 1	BER	1,2 %	1,3 %	0,35 %
TCH/2,4 N = 4	BER	0,02 %	0,3 %	0,01 %
TCH/2,4 N = 8	BER	0,01 %	0,15 %	0,01 %
STCH	MER	9 %	11 %	8 %

NOTE: N gives the interleaving depth in number of blocks (see clause 8).

#### 6.6.2.2.2 MS receiver performance

**Table 11: Maximum permissible MS receiver MER or BER at dynamic reference sensitivity level**

Logical channel	Error count type	Continuous downlink mode			Discontinuous downlink mode		Propagation condition
		Propagation condition			Propagation condition		
		TU50	HT200	EQ200	TU50	HT200	TU50
		Class A, E	Class A	Class E	Class A	Class A	Class B
AACH	MER	10 %	17 %	16 %	10 %	17 %	11 %
BSCH	MER	8 %	11 %	22 %	8 %	11 %	8 %
SCH/HD	MER	8 %	11 %	21 %	9 %	11 %	8 %
BNCH	MER	8 %	11 %	21 %	9 %	11 %	8 %
SCH/F	MER	8 %	11 %	22 %	11 %	11 %	8 %
TCH/7,2	BER	2,5 %	4 %	4,5 %	2,5 %	4 %	2,2 %
TCH/4,8 N = 1	BER	2 %	4 %	6,4 %	4 %	4 %	2 %
TCH/4,8 N = 4	BER	0,4 %	3,3 %	2,7 %	1,2 %	4 %	0,4 %
TCH/4,8 N = 8	BER	0,06 %	3 %	1,5 %	0,4 %	4 %	0,06 %
TCH/2,4 N = 1	BER	0,35 %	1,1 %	0,82 %	1,2 %	1,3 %	0,35 %
TCH/2,4 N = 4	BER	0,01 %	0,4 %	0,017 %	0,02 %	0,4 %	0,01 %
TCH/2,4 N = 8	BER	0,01 %	0,13 %	0,01 %	0,01 %	0,2 %	0,01 %
STCH	MER	8 %	11 %	21 %	9 %	11 %	8 %

NOTE 1: N gives the interleaving depth in number of blocks (see clause 8).  
NOTE 2: Class B receiver performance are for both Continuous and Discontinuous downlink mode.

### 6.6.2.3 Receiver performance at reference interference ratios

The minimum required reference interference performance (for co-channel,  $C/I_c$ , or adjacent channel,  $C/I_a$ ) is specified according to the logical channel, the propagation condition and the receiver class at the reference interference ratio. The reference interference ratio shall be, for BS and all types of MS:

- for co-channel interference:  $C/I_c = 19$  dB;
- for adjacent channel interference below 700MHz  $C/I_a = -40$  dB for MS and  $C/I_a = -45$  dB for BS;
- for adjacent channel interference above 700MHz  $C/I_a = -40$  dB.

In case of co-channel interference these specifications apply for a wanted input signal level of -85 dBm, and in case of adjacent channel interference for a wanted input signal level 3 dB above the dynamic reference sensitivity level. In the case of co-channel interference the interference shall be a continuous TETRA random modulated signal subjected to an independent realization of the same propagation condition as the wanted signal. In the case of adjacent channel interference the interference shall be a continuous TETRA random modulated signal subjected to static propagation conditions.

In tables 12 and 13 the performance for TU50, HT200 or EQ200 propagation conditions is given for the reference interference level. For BSCH, SCH/HD, SCH/HU, SCH/F, BNCH, a PUEM  $< 10^{-5}$  shall be achieved at the reference interference level. For AACH a PUEM  $< 10^{-4}$  shall be achieved at the reference interference level.

#### 6.6.2.3.1 BS receiver performance

**Table 12: Maximum permissible BS receiver MER or BER at reference interference level**

Logical channel	Error count type	Class A		Class B
		Propagation condition		Propagation condition
		TU50	HT200	TU50
SCH/HU	MER	6,5 %	9,5 %	6,5 %
SCH/F	MER	6 %	9,2 %	6 %
TCH/7,2	BER	2 %	3,7 %	2 %
TCH/4,8 N= 1	BER	4 %	4 %	2 %
TCH/4,8 N= 4	BER	1,2 %	4 %	0,4 %
TCH/4,8 N= 8	BER	0,4 %	4 %	0,06 %
TCH/2,4 N= 1	BER	1,2 %	1,3 %	0,35 %
TCH/2,4 N= 4	BER	0,02 %	0,3 %	0,01 %
TCH/2,4 N= 8	BER	0,01 %	0,15 %	0,01 %
STCH	MER	7 %	9,2 %	7 %

NOTE: N gives the interleaving depth in number of blocks (see clause 8).

## 6.6.2.3.2 MS receiver performance

Table 13: Maximum permissible MS receiver MER or BER at reference interference level

Logical channel	Error count type	Continuous downlink mode			Discontinuous downlink mode		Prop. Cond.
		Propagation condition			Propagation condition		
		TU50	HT200	EQ200	TU50	HT200	
		Class A, E	Class A	Class E	Class A	Class A	Class B
AACH	MER	9 %	16 %	14 %	9 %	16 %	9 %
BSCH	MER	6 %	10 %	20 %	6 %	10 %	6 %
SCH/HD	MER	7 %	9,2 %	20 %	7 %	9,2 %	7 %
BNCH	MER	7 %	9,2 %	20 %	7 %	9,2 %	7 %
SCH/F	MER	6,5 %	9,2 %	20 %	6,5 %	7,5 %	6,5 %
TCH/7,2	BER	2 %	3,8 %	4,2 %	2 %	3,8 %	2 %
TCH/4,8 N= 1	BER	2 %	4 %	6,2 %	4 %	4 %	2 %
TCH/4,8 N= 4	BER	0,4 %	3,3 %	2,5 %	1,2 %	4 %	0,4 %
TCH/4,8 N= 8	BER	0,06 %	3 %	1,2 %	0,4 %	4 %	0,06 %
TCH/2,4 N= 1	BER	0,35 %	1,1 %	0,84 %	1,2 %	1,3 %	0,35 %
TCH/2,4 N= 4	BER	0,01 %	0,4 %	0,01 %	0,02 %	0,4 %	0,01 %
TCH/2,4 N= 8	BER	0,01 %	0,13 %	0,01 %	0,01 %	0,2 %	0,01 %
STCH	MER	7 %	9,2 %	20 %	7 %	9,2 %	7 %

NOTE 1: N gives the interleaving depth in number of blocks (see clause 8).  
NOTE 2: Class B receiver performance are for both Continuous and Discontinuous downlink mode.

## 6.6.2.4 Static reference sensitivity performance

The minimum required static reference sensitivity performance is specified according to the logical channel and the receiver class at the static reference sensitivity level. The static reference sensitivity level shall be:

- for MS: -112 dBm;
- for BS: -115 dBm.

Table 14 and table 15 give the minimum required reference sensitivity performance. For BSCH, SCH/HD, SCH/HU, SCH/F, BNCH, a PUEM < 0,001 % shall be achieved at the static reference sensitivity level. For AACH a PUEM < 0,01 % shall be achieved at the static reference sensitivity level.

## 6.6.2.4.1 BS receiver performance

Table 14: Maximum permissible BS receiver MER or BER at static reference sensitivity level

Logical channel	Error count type	Class A	Class B
SCH/HU	MER	3 %	3 %
SCH/F	MER	10 %	10 %
TCH/7,2	BER	3 %	4 %
TCH/4,8 N= 1	BER	3,3 %	0,3 %
TCH/4,8 N= 4	BER	1 %	0,2 %
TCH/4,8 N= 8	BER	0,4 %	0,2 %
TCH/2,4 N= 1	BER	0,2 %	0,01 %
TCH/2,4 N= 4	BER	0,01 %	0,01 %
TCH/2,4 N= 8	BER	0,01 %	0,01 %
STCH	MER	8 %	5 %

NOTE: N gives the interleaving depth in number of blocks (see clause 8).

## 6.6.2.4.2 MS receiver performance

**Table 15: Maximum permissible MS receiver MER or BER at static reference sensitivity level**

Logical channel	Error count type	Continuous downlink mode	Discontinuous downlink mode	Class B
		Class A,E	Class A	
AACH	MER	28 %	28 %	38 %
BSCH	MER	3 %	3 %	3 %
SCH/HD	MER	2,5 %	8 %	5 %
BNCH	MER	2,5 %	8 %	5 %
SCH/F	MER	4,5 %	9 %	9 %
TCH/7,2	BER	3,5 %	3,5 %	4 %
TCH/4,8 N = 1	BER	0,3 %	2 %	0,3 %
TCH/4,8 N = 4	BER	0,2 %	0,8 %	0,2 %
TCH/4,8 N = 8	BER	0,15 %	0,4 %	0,15 %
TCH/2,4 N = 1	BER	0,01 %	0,01 %	0,01 %
TCH/2,4 N = 4	BER	0,01 %	0,01 %	0,01 %
TCH/2,4 N = 8	BER	0,01 %	0,01 %	0,01 %
STCH	MER	2,5 %	8 %	5 %

NOTE 1: N gives the interleaving depth in number of blocks (see clause 8).  
NOTE 2: Class B receiver performance are for both Continuous and Discontinuous downlink mode.

## 6.6.2.5 MS receiver performance for synchronization burst acquisition

This clause specifies reference sensitivity performance of a MS receiver for the acquisition of the Synchronization (sub) Burst (SB). The performance is defined in terms of the probability PACQ of detecting a single transmitted SB and correctly decoding its BSCH information for the condition where the MS is listening on the frequency while the SB is transmitted and where the MS is already frequency synchronized but not synchronized in terms of time slots.

**Table 16: MS receiver performance for synchronization burst acquisition**

Propagation condition/eq. class	TU50/class B	HT200/class A, E
PACQ	0,8	0,8

NOTE: This specification applies for continuous and discontinuous downlink mode.

## 6.6.3 Propagation conditions

The following clauses contains all necessary information on the propagation models that are referred to in the present document.

## 6.6.3.1 Propagation conditions - introduction

Radio wave propagation in the mobile radio environment is described by dispersive multipath caused by reflection, diffraction and scattering. Different paths may exist between a BS and a MS due to large distant reflectors and/or scatterers and due to scattering in the vicinity of the mobile, giving rise to a number of partial waves arriving with different amplitudes and delays. Since the mobile will be moving, a Doppler shift is associated with each partial wave, depending on the mobile's velocity and the angle of incidence. The delayed and Doppler shifted partial waves interfere at the receiver causing frequency and time selective fading on the transmitted signal.

When system bandwidth and propagation path lengths are sufficiently small (which is the case for TETRA), the resulting frequency and time selective fading process may be simulated by a simplified propagation model. Such a model exhibits only a few discrete paths which are independently fading. For practical channel simulation, stationary Gaussian processes with a power density spectrum equal to the classical Doppler spectrum are commonly assumed.

Based on extensive investigations (Digital Land Mobile Radiocommunications, M. Failli (Ed.), Final Report 14.3.1984-13.9.1988, published by European Commission, Directorate of General Telecommunication, Information Industries and Innovation. Luxembourg. ISBN 92-825-9946-9. (1989)) some tapped delay line models which are typical for urban, rural, or hilly area propagation conditions or for quasi-synchronous operation were derived. These models are defined in the following terms (see also table 17):

- number of discrete taps;
- relative delay of each tap;
- average relative power of the complex tap-gain process of each tap;
- type of the complex tap-gain process of each tap.

All stochastic tap-gain processes are mutually statistically independent.

### 6.6.3.2 Tap-gain process types

This clause defines the statistical properties of the stationary complex tap-gain processes, to be applied for the propagation models, in terms of a Probability Density Function (PDF) and a Power Density Spectrum (PDS) which models the Doppler spectrum. The complex tap-gain processes, desee noted by  $a(t)$  and defined hereunder, are normalized to unity power.

CLASS is the tap-gain process having a PDS equal to the classical Doppler spectrum. The real and imaginary parts of  $a(t)$  exhibit an identical Gaussian PDF, an identical PDS and are mutually statistically independent. Hence  $|a(t)|$  is Rayleigh distributed. The PDS of  $a(t)$  is defined by:

$$S(f) = S_{CLASS}(f, f_d) = \frac{1}{\pi f_d \sqrt{1 - (f/f_d)^2}} \quad \text{for } -f_d < f < f_d; \text{ and}$$

$$S(f) = 0 \quad \text{elsewhere} \quad (13)$$

Where the parameter  $f_d$  represents the maximum Doppler shift (in Hz), defined as  $f_d = v/\lambda$  with the vehicle speed  $v$  (in m/s) and the wavelength  $\lambda$  (in m).

STATIC( $f_s$ ) is a tap-gain process with a constant magnitude  $|a(t)| = 1$ . The PDS of  $a(t)$  is defined by:

$$S(f) = S_{STATIC}(f, f_s) = \delta(f - f_s) \quad (14)$$

Where  $\delta(\cdot)$  represents the Dirac delta function and  $f_s$  the Doppler shift (in Hz).

RICE is a tap-gain process which is the sum process of the two processes CLASS and STATIC( $f_s$ ), with  $f_s = 0,7 f_d$ , each contributing half of the total power. Hence  $|a(t)|$  is Rician distributed and the PDS is:

$$S(f) = S_{RICE}(f, f_d) = 0,5 S_{CLASS}(f, f_d) + 0,5 S_{STATIC}(f, 0,7 f_d) \quad (15)$$

### 6.6.3.3 Propagation models

In this clause, the propagation models that are referred to in the present document are defined. Three models are used TU50, HT200 and EQ200. The vehicle speed  $x$  (in km/h), which affects  $f_d$  (see clause 6.6.3.2), is attributed to the model designation in the frequency range 380 MHz to 520 MHz (e.g. HT200 means Hilly Terrain for 200 km/h in the 380 MHz to 520 MHz frequency range).

To keep the Doppler shift constant relative to 430 MHz, for frequencies outside the 380 MHz to 520 MHz range, for testing purposes only, the vehicle speed in the model is adjusted according the formula:

- $v = 20 \text{ [Hz]} \times \lambda \text{ [m]}$ , when TU50 is specified;
- $v = 80 \text{ [Hz]} \times \lambda \text{ [m]}$ , when HT200 and EQ200 are specified.

NOTE:  $x = v \times 3,6$ .

**Table 17: Propagation models**

Propagation model	Tap number	Relative delay ( $\mu\text{s}$ )	Average relative power (dB)	Tap-gain process
Static	1	0	0	STATIC(0)
Rural Area (RAx)	1	0	0	RICE
Typical Urban (TUx)	1	0	0	CLASS
	2	5	-22,3	CLASS
Bad Urban (BUx)	1	0	0	CLASS
	2	5	-3,0	CLASS
Hilly Terrain (HTx)	1	0	0	CLASS
	2	15	-8,6	CLASS
Equalizer Test (EQx)	1	0	0	CLASS
	2	11,6	0	CLASS
	3	73,2	-10,2	CLASS
	4	99,3	-16	CLASS

---

## 7 Radio sub-system synchronization

### 7.1 Introduction

This clause defines the requirements for synchronization on the TETRA V+D radio sub-system, for carrier frequencies of between 300 MHz and 1 GHz. It does not define the synchronization algorithms to be used in the BS and MS. These are up to the manufacturer to specify.

### 7.2 General description of synchronization system

This clause gives a general description of the synchronization system. Detailed requirements are given in the subsequent clauses.

The BS sends signals on the BSCH to enable the MS to synchronize itself to the BS and if necessary correct its frequency standard to be in line with that of the BS. The signals sent by the BS for these purposes are frequency correction signals and synchronization signals.

The timings of timeslots, TDMA frames and multiframes are all related to a common set of counters which run continuously whether the MS and BS are transmitting or not (see clause 7.3). Thus, once the MS has determined the correct setting of these counters, all its processes are synchronized to the current serving BS.

The MS has to time its transmissions to the BS in line with those received from the BS. This process is called "mobile timebase adjustment".



## 7.3 Timebase counters

### 7.3.1 Timing counters

The timing state of the signals transmitted by a BS or MS shall be defined by the following counters:

- Quarter symbol Number ( $QN$ ) (1 - 1020);
- Symbol Number ( $SN$ ) (1 - 255);
- Timeslot Number ( $TN$ ) (1 - 4);
- TDMA Frame Number ( $FN$ ) (1 - 18);
- TDMA Multiframe Number ( $MN$ ) (1 - 60).

### 7.3.2 Values of the counters

The relationship between these counters shall be as follows:

- $QN$  increments every  $125/9 \mu\text{s}$  (for an MS, this holds unless otherwise required by the mobile timebase adjustment);
- $SN = \text{integer part of } (QN+3)/4$ ;
- $TN$  increments whenever  $QN$  changes from count 1 020 to 1;
- $FN$  increments whenever  $TN$  changes from count 4 to 1;
- $MN$  increments whenever  $FN$  changes from 18 to 1.

The simultaneous change of state of all counters to 1 defines the timebase reference. This timebase reference takes into account the offset required in the case of MCCH sharing ( $\pm 18$  frames).

## 7.4 Timing of transmitted signals

The timing of modulation symbols transmitted by the MS and BS is defined in clause 9.

The MS may use the timing of receipt of the synchronization burst to set-up its timebase counters. If it does, it shall do so as follows:

- $QN$  shall be set by the timing of the training sequence;
- the value of  $TN$  shall be read from the BSCH, when received. In any other case, augmentation of  $TN$  shall be given by:

$$TN: = TN \bmod (4) + 1 \quad (16)$$

- the value of  $FN$  shall be read from the BSCH, when received. In any other case, augmentation of  $FN$  shall be given by:

$$FN: = FN \bmod (18) + 1 \quad (17)$$

- the value of  $MN$  is read from the BSCH, when received. In any other case, augmentation of  $MN$  shall be given by:

$$MN: = MN \bmod (60) + 1 \quad (18)$$

When BSs that differ from the current serving BS are being monitored for call re-establishment or handover purposes, the MS may choose to store the values of  $QN$ ,  $TN$ ,  $FN$  and  $MN$  for all the BSs whose synchronization bursts have been detected relative to  $QN$ ,  $TN$ ,  $FN$  and  $MN$  for its current serving BS.

## 7.5 BS requirements for synchronization

The BS shall use a single frequency source with accuracy better than  $\pm 0,2$  ppm ( $\pm 0,1$  ppm for frequencies above 520 MHz) for both RF frequency generation and clocking the timebase. The same source shall be used for all carriers of the BS.

It is optional whether the timebase counters of different BSs are synchronized together.

The channels of different carriers transmitted by a BS shall be synchronized together, i.e. controlled by the same set of counters. The timing difference between the different carriers shall be less than  $\frac{1}{4}$  symbol duration. In case of timesharing of the same carrier by different BSs, the timing difference between the timebase references of two any such BS shall be less than  $\frac{1}{2}$  symbol duration.

## 7.6 MS requirements for synchronization

The MS shall only transmit to the BS if the requirements of items a) to c) below are met.

- a) The MS carrier frequency shall be accurate to within  $\pm 100$  Hz compared to signals received from the BS (these signals may have an apparent frequency error due to BS frequency error and Doppler shift). The signals from the BS shall be averaged by the MS over sufficient time that errors due to noise or interference are allowed for within the above  $\pm 100$  Hz figure.
- b) The MS shall adjust its internal timebase in line with that of signals received from the BS. If the MS determines that the timing difference exceeds  $\frac{1}{4}$  symbol duration, it shall adjust its timebase in steps of not greater than  $\frac{1}{4}$  symbol duration. This adjustment shall be performed at intervals of not less than 1 second and not greater than 3 s until the timing difference is less than  $\frac{1}{4}$  symbol duration.
- c) In determining the timing of signals from the BS, the timings shall be assessed in such a way that the timing assessment error is less than  $\frac{1}{8}$  symbol duration. The assessment algorithm shall be such that the requirements of (b) can be met.

The conditions under which the requirements of items a) to c) shall be met shall be 3 dB below the reference sensitivity level defined in clause 6 and 3 dB less carrier to interference ratio than the reference interference ratios defined in clause 6. Static or dynamic reference sensitivity levels shall be used depending on the applied propagation conditions.

---

# 8 Channel coding and scrambling

## 8.1 Introduction

A reference configuration of the TETRA transmission chain is given in clause 4. According to the reference configuration, this clause defines the error control process which applies to the information bits packed in MAC blocks (see definition in clause 19), and which provides multiplexed bits packed in multiplexed blocks.

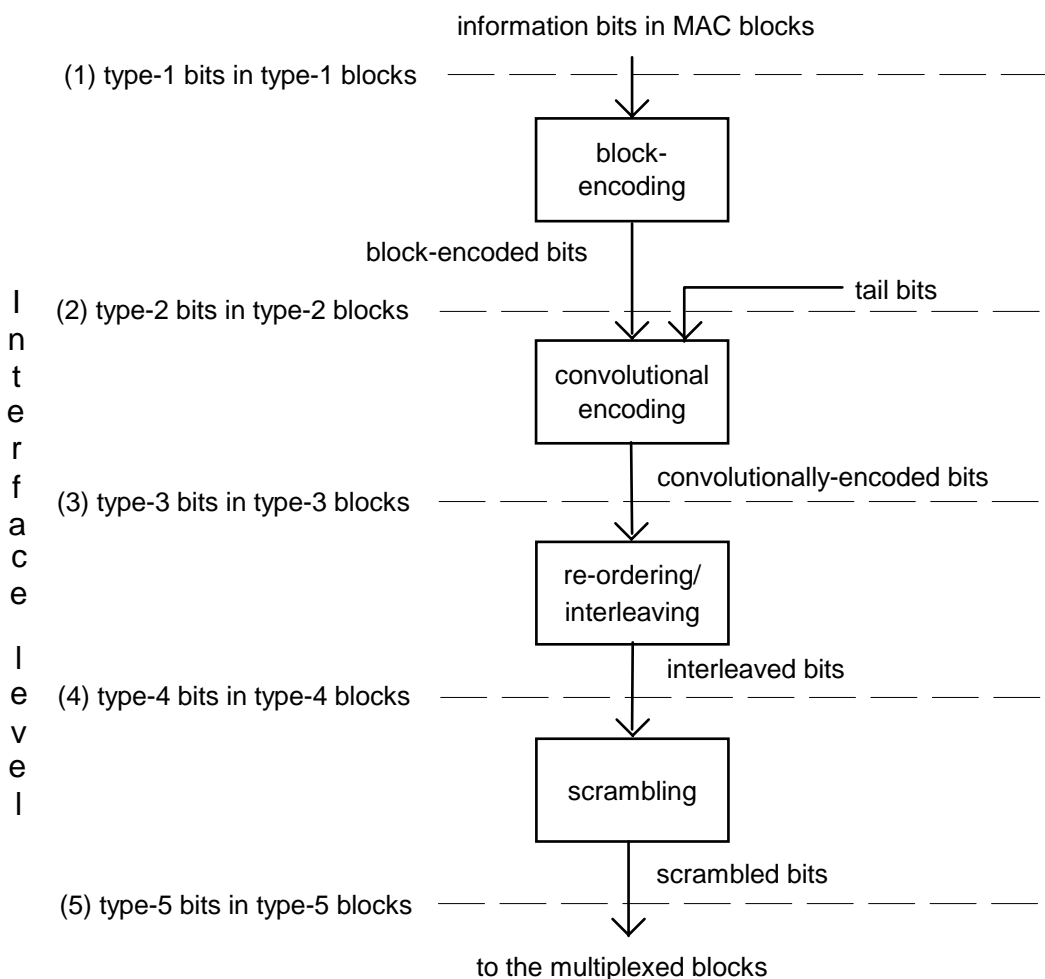
This clause applies to all logical channels, however channel coding for speech service is defined in ETS 300 395-2 [40] clause 5. The definition of logical channels is given in clause 9.

This clause includes the specification of encoding, re-ordering and interleaving, and scrambling, but does not specify any data processing on the receive part.

A definition of the error control process is provided for each kind of logical channel.

## 8.2 General

### 8.2.1 Interfaces in the error control structure



**Figure 8: Interfaces in the error control structure**

The definition of interfaces within the error control structure is given by figure 8.

Each logical channel shall have its own error control scheme. For each one, the information bits (eventually including a MAC header) are referred to as type-1 bits. The type-1 bits are packed in MAC blocks (see clause 19), which are referred to as type-1 blocks, this defines interface (1) in figure 8.

The processing in the transmit part shall be as follows:

- the type-1 bits shall be encoded by a block code, providing block-encoded bits. In some cases tail bits shall be appended to these block-encoded bits. The block-encoded bits and the tail bits (if added) are referred to as type-2 bits and shall be packed in a type-2 block, this defines interface (2);
- the type-2 bits shall be encoded by a convolutional code, which provides the convolutionally encoded bits. The convolutionally-encoded bits are referred to as type-3 bits and shall be packed in a type-3 block, this defines interface (3);
- the type-3 bits shall be reordered and interleaved, into interleaved bits: the interleaved bits are referred to as type-4 bits and shall be packed in encoded blocks (see clause 19). Encoded blocks are referred to as type-4 blocks, this defines interface (4);
- the type-4 bits shall be scrambled, into type-5 bits, which compose type-5 blocks: this defines the interface (5). These bits shall then be mapped into multiplexed blocks. A multiplexed block shall be one of 5 different kinds: control block, BBK, synchronization block, block-1 block, or block-2 block.

All these operations are made on a per type-1 block basis. The sizes of type-1 blocks and of type-5 blocks and multiplexed blocks depend on the logical channel with which they are associated.

## 8.2.2 Notation

For ease of understanding, a notation for bits and blocks is given for use throughout this clause:

- $x$  is the interface number, as defined in figure 8:  $x = 1, 2, 3, 4, 5$ ;
- $n$  is a block number;
- $Bx(n)$  is the type- $x$  block number  $n$ ;
- $Kx$  is the number of bits that are carried by one type- $x$  block;
- $k$  is a bit number;
- $bx(n,k)$  is the type- $x$  bit number  $k$  in the type- $x$  block number  $n$ ;
- alternatively  $bx(k)$  is the type- $x$  bit number  $k$  in a type- $x$  block (for ease of notation), with  $k = 1, 2, \dots, Kx$ , and  $n = 1, 2, \dots$

The bits of the multiplexed blocks shall be desee noted as:

- $cb(k)$ : bit number  $k$  in an control block;
- $bb(k)$ : bit number  $k$  in a BBK;
- $sb(k)$ : bit number  $k$  in a synchronization block;
- $bkn1(k)$ : bit number  $k$  in a block-1 block;
- $bkn2(k)$ : bit number  $k$  in a block-2 block.

## 8.2.3 Definition of error control codes

### 8.2.3.1 16-state Rate-Compatible Punctured Convolutional (RCPC) codes

The RCPC codes shall encode  $K_2$  type-2 bits  $b_2(1), b_2(2), \dots, b_2(K_2)$  into  $K_3$  type-3 bits  $b_3(1), b_3(2), \dots, b_3(K_3)$ . This encoding shall be performed in two steps:

- encoding by a 16-state mother code of rate  $\frac{1}{4}$ ;
- puncturing of the mother code so to obtain a 16-state RCPC code of rate  $K_2/K_3$ .

A general description of these two steps is given in clauses 8.2.3.1.1 and 8.2.3.1.2 respectively. The puncturing co-efficients of the 16-state RCPC codes of rates  $2/3$ ,  $1/3$ ,  $292/432$  and  $148/432$  are given in clauses 8.2.3.1.3, 8.2.3.1.4, 8.2.3.1.5 and 8.2.3.1.6 respectively.

#### 8.2.3.1.1 Encoding by the 16-state mother code of rate $\frac{1}{4}$

The input to the mother code of any type-2 bit  $b_2(k)$ ,  $k = 1, 2, \dots, K_2$ , implies the output, by the mother code, of 4 bits, desee noted by  $V(4(k-1)+i)$ ,  $i = 1, 2, 3, 4$ , which shall be calculated as follows.

Any of the 4 generator polynomials of the mother code,  $G_i(D)$ ,  $i = 1, 2, 3, 4$ , can be written as:

$$G_i(D) = \sum_{j=0}^4 g_{i,j} D^j \quad \text{for } i = 1, 2, 3, 4 \quad (19)$$

Where  $g_{i,j} = 0$  or  $1$ ,  $j = 0, 1, 2, 3, 4$ .

This means that the encoded bits are defined by:

$$V(4(k-1) + i) = \sum_{j=0}^4 b_2(k-j)g_{i,j} \quad \text{for } i = 1, 2, 3, 4, \text{ and } k = 1, 2, \dots, K_2. \quad (20)$$

Where the sum is meant modulo 2, and where  $b_2(k-j) = 0$  for  $k \leq j$ .

The generator polynomials of the mother code shall be:

$$G_1(D) = 1 + D + D^4 \quad (21)$$

$$G_2(D) = 1 + D_2 + D_3 + D_4 \quad (22)$$

$$G_3(D) = 1 + D + D^2 + D^4 \quad (23)$$

$$G_4(D) = 1 + D + D^3 + D^4 \quad (24)$$

### 8.2.3.1.2 Puncturing of the mother code

The puncturing of the mother code into a 16-state RCPC code of rate  $(K_2/K_3)$  is achieved by selecting  $K_3$  type-3 bits out of the  $(4 K_2)$  bits encoded by the mother code. This selection shall be as follows.

Denoting by  $P(1), P(2), \dots, P(t)$  the  $t$  puncturing co-efficients (each one being equal to 1, 2, 3, 4, 5, 6, 7, or 8), the type-3 bits are given by:

$$b_3(j) = V(k) \quad \text{for } j = 1, 2, \dots, K_3 \quad (25)$$

with  $k = 8((i-1) \text{ div } t) + P(i - t((i-1) \text{ div } t))$

Where  $i$  and  $t$  are defined in the following puncturing schemes.

### 8.2.3.1.3 Puncturing scheme of the RCPC code of rate 2/3

The  $t = 3$  puncturing co-efficients shall be:

$$P(1) = 1, P(2) = 2, P(3) = 5, \text{ and } i = j \quad (26)$$

### 8.2.3.1.4 Puncturing scheme of the RCPC code of rate 1/3

The  $t = 6$  puncturing co-efficients shall be:

$$P(1) = 1, P(2) = 2, P(3) = 3, P(4) = 5, P(5) = 6, P(6) = 7, \text{ and } i = j \quad (27)$$

### 8.2.3.1.5 Puncturing scheme of the RCPC code of rate 292/432

The  $t = 3$  puncturing co-efficients shall be:

$$P(1) = 1, P(2) = 2, P(3) = 5, \text{ and } i = j + (j-1) \text{ div } 65, \text{ with } j = 1, 2, \dots, 432 \quad (28)$$

### 8.2.3.1.6 Puncturing scheme of the RCPC code of rate 148/432

The  $t = 6$  puncturing co-efficients shall be:

$$P(1) = 1, P(2) = 2, P(3) = 3, P(4) = 5, P(5) = 6, P(6) = 7, \text{ and } i = j + (j-1) \text{ div } 35, \text{ with } j = 1, 2, \dots, 432 \quad (29)$$

### 8.2.3.2 Shortened (30,14) Reed-Muller (RM) code

The shortened (30,14) RM code shall encode 14 type-1 bits  $b_1(1), b_1(2), \dots, b_1(14)$  into 30 type-2 bits  $b_2(1), b_2(2), \dots, b_2(30)$ .

The vector of the 30 type-2 bits shall be derived from:

$$[b_2(1), b_2(2), \dots, b_2(30)] = [b_1(1), b_1(2), \dots, b_1(14)] \quad \mathbf{G} \quad (30)$$

Where  $\mathbf{G}$  is the generator matrix:

$$\mathbf{G} = \begin{bmatrix} \mathbf{I}_{14} & \begin{matrix} 1 & 1 & 0 & 0 & 0 & 0 & 0 & 0 & 0 & 0 & 0 & 0 & 0 & 0 \\ 1 & 1 & 1 & 0 & 0 & 0 & 0 & 0 & 0 & 0 & 1 & 1 & 1 & 1 & 0 & 0 \\ 1 & 0 & 0 & 1 & 1 & 0 & 0 & 0 & 0 & 0 & 1 & 1 & 1 & 0 & 1 & 0 \\ 0 & 1 & 0 & 1 & 0 & 1 & 0 & 0 & 0 & 0 & 1 & 1 & 0 & 1 & 1 & 0 \\ 0 & 0 & 1 & 0 & 1 & 1 & 0 & 0 & 0 & 0 & 1 & 0 & 1 & 1 & 1 & 0 \\ 1 & 1 & 1 & 1 & 1 & 1 & 1 & 1 & 1 & 1 & 0 & 1 & 1 & 1 & 1 & 1 \\ 1 & 0 & 0 & 0 & 0 & 0 & 1 & 1 & 0 & 0 & 1 & 1 & 1 & 0 & 0 & 1 \\ 0 & 1 & 0 & 0 & 0 & 0 & 1 & 0 & 1 & 0 & 1 & 1 & 0 & 1 & 0 & 1 \\ 0 & 0 & 1 & 0 & 0 & 0 & 0 & 1 & 1 & 0 & 1 & 0 & 1 & 1 & 0 & 1 \\ 0 & 0 & 0 & 1 & 0 & 0 & 1 & 0 & 0 & 1 & 1 & 1 & 0 & 0 & 1 & 1 \\ 0 & 0 & 0 & 0 & 1 & 0 & 0 & 1 & 0 & 1 & 1 & 0 & 1 & 0 & 1 & 1 \\ 0 & 0 & 0 & 0 & 0 & 1 & 0 & 0 & 1 & 1 & 1 & 0 & 0 & 1 & 1 & 1 \end{matrix} \end{bmatrix} \quad (31)$$

Where  $\mathbf{I}_{14}$  desee notes the (14 x 14) identity matrix.

### 8.2.3.3 $(K_1 + 16, K_1)$ block code

The  $(K_1 + 16, K_1)$  code shall encode  $K_1$  type-1 bits  $b_1(1), b_1(2), \dots, b_1(K_1)$  into  $(K_1 + 16)$  type-2 bits  $b_2(1), b_2(2), \dots, b_2(K_1 + 16)$ . The encoding rule shall be as follows (see ITU-T Recommendation X.25 [1]).

The type-1 bits are treated as the co-efficients of the polynomial:

$$M(X) = \sum_{k=1}^{K_1} b_1(k) X^{K_1 - k} \quad (32)$$

Let  $F(X)$  be:

$$F(X) = \left[ \left( X^{16} M(X) + X^{K_1} \sum_{i=0}^{15} X^i \right) \bmod G(X) \right] + \sum_{i=0}^{15} X^i \quad (33)$$

Where all operations are meant modulo 2, and  $G(X)$  is the generator polynomial of the code:

$$G(X) = X^{16} + X^{12} + X^5 + 1 \quad (34)$$

$F(X)$  is of degree 15, with co-efficients desee noted by  $f(0), f(1), \dots, f(15)$ :

$$F(X) = \sum_{i=0}^{15} f(i) X^i \quad (35)$$

The  $K_2$  type-2 bits, with  $K_2 = K_1 + 16$ , are then given by:

$$b_2(k) = b_1(k) \quad \text{for } k = 1, 2, \dots, K_1; \text{ and}$$

$$b_2(k) = f(K_1 + 16 - k) \quad \text{for } k = K_1 + 1, K_1 + 2, \dots, K_1 + 16. \quad (36)$$

## 8.2.4 Definition of interleaving schemes

### 8.2.4.1 Block interleaving

A  $(K, a)$  block interleaver shall re-order  $K_3$  type-3 bits  $b_3(1), b_3(2), \dots, b_3(K_3)$  into  $K_4$  type-4 bits  $b_4(1), b_4(2), \dots, b_4(K_4)$ , with  $K = K_3 = K_4$ , in the following way:

$$b_4(k) = b_3(i), \quad i = 1, 2, \dots, K \quad (37)$$

with  $k = 1 + ((a \times i) \bmod K)$

### 8.2.4.2 Interleaving over $N$ blocks

Interleaving over  $N$  blocks use two steps to interleave a sequence of  $M$  type-3 blocks  $B_3(1), B_3(2), \dots, B_3(M)$  of 432 bits each into a sequence of  $(M + N - 1)$  type-4 blocks  $B_4(1), B_4(2), \dots, B_4(M + N - 1)$  of 432 bits each, where  $M$  is an integer and  $N$  has values 1, 4, or 8. This interleaving shall be as follows.

Firstly, a diagonal interleaver interleaves the  $M$  blocks  $B_3(1), B_3(2), \dots, B_3(M)$  into  $(M + N - 1)$  blocks  $B'_3(1), B'_3(2), \dots, B'_3(M + N - 1)$ . Denoting by  $b'_3(m, k)$  the  $k$ -th bit of block  $B'_3(m)$ , with  $k = 1, 2, \dots, 432$  and  $m = 1, 2, \dots, M + N - 1$ ,

$$b'_3(m, k) = b_3(m - j, j + 1 + (i \times N)) \quad \text{for } 1 \leq m - j \leq M;$$

$$b'_3(m, k) = 0 \quad \text{otherwise; } \quad (38)$$

with  $j = (k - 1) \operatorname{div} (432/N)$ , and  $i = (k - 1) \bmod (432/N)$ .

A block interleaver then interleaves each block  $B'_3(m)$  into type-4 block  $B_4(m)$ ,  $m = 1, 2, \dots, M + N - 1$ :

$$b_4(m, i) = b'_3(m, k) \quad (39)$$

with  $k = 1, 2, \dots, 432$ , and  $i = 1 + [(103 \times k) \bmod 432]$

## 8.2.5 Definition of scrambling

### 8.2.5.1 Scrambling method

Scrambling shall transform  $K_4$  type-4 bits  $b_4(1), b_4(2), \dots, b_4(K_4)$  into  $K_5$  type-5 bits  $b_5(1), b_5(2), \dots, b_5(K_5)$ , with  $K_5 = K_4$ , as follows:

$$b_5(k) = b_4(k) + p(k) \quad \text{for } k = 1, 2, \dots, K_5 \quad (40)$$

Where the addition is meant modulo 2, and  $p(k)$  is the  $k$ -th bit of the scrambling sequence.

### 8.2.5.2 Scrambling sequence

The scrambling sequence  $\{p(k), k = 1, 2, \dots, K_5\}$  shall be generated from the 30 bits of the extended colour code  $e(1), e(2), \dots, e(30)$  (see clauses 19 and 23), except for the BSCH, by means of linear feedback registers. For the scrambling of BSCH, all bits  $e(1), e(2), \dots, e(30)$  shall be set equal to zero.

The scrambling sequence generator shall be based upon the following connection polynomial:

$$c(x) = \sum_{i=0}^{32} c_i X^i \quad (41)$$

With  $c_i = 1$  for  $i = 0, 1, 2, 4, 5, 7, 8, 10, 11, 12, 16, 22, 23, 26$  and  $32$ , and  $c_i = 0$  elsewhere and where all operations are meant modulo 2. The resultant polynomial is therefore:

$$c(x) = 1 + X + X^2 + X^4 + X^5 + X^7 + X^8 + X^{10} + X^{11} + X^{12} + X^{16} + X^{22} + X^{23} + X^{26} + X^{32} \quad (42)$$

The  $k$ -th bit of the scrambling sequence is given by:

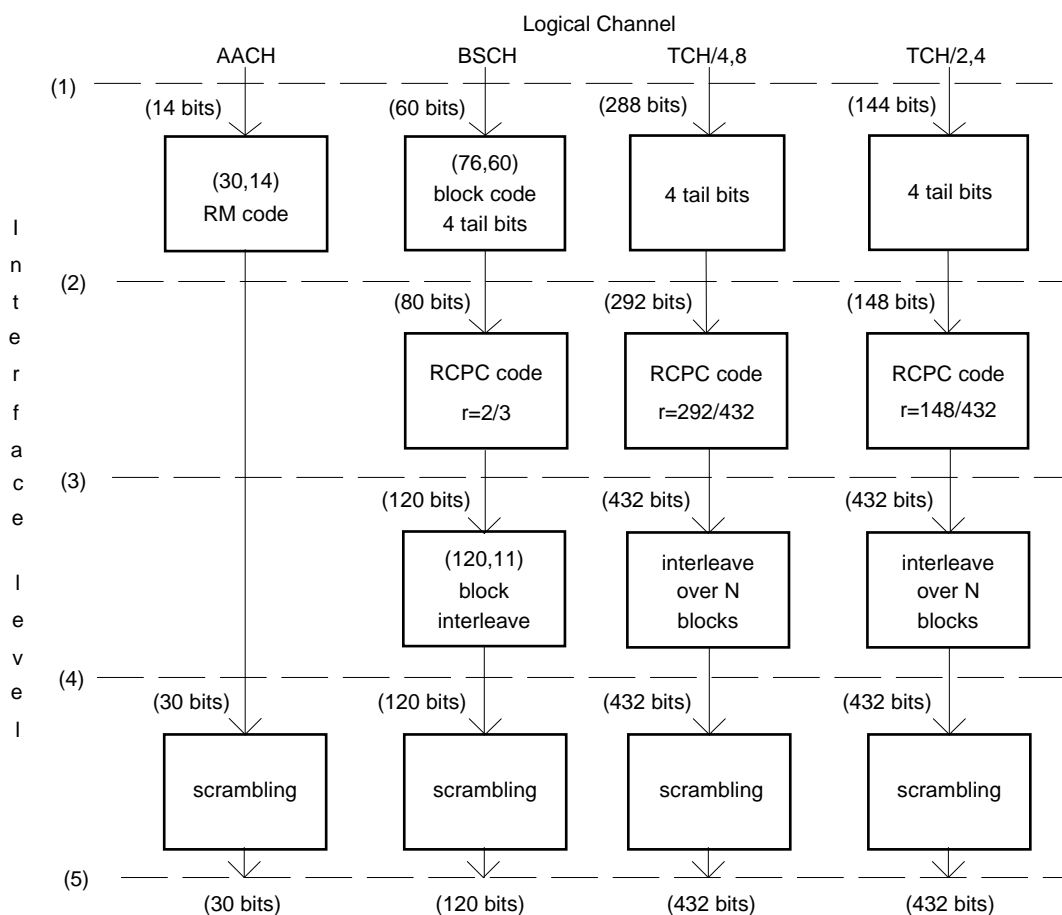
$$p(k) = \sum_{i=1}^{32} c_i p(k-i) \quad (43)$$

With the following initialization:

$$p(k) = e^{(1-k)} \text{ for } k = -29, -28, \dots, 0; \text{ and}$$

$$p(k) = 1 \text{ for } k = -31, -30 \quad (44)$$

## 8.3 Error control schemes



**Figure 9: Error control structure for V+D logical channels (part 1)**

In this clause the error control scheme associated with each logical channel is defined. Figures 9 and 10 give the error control structure.



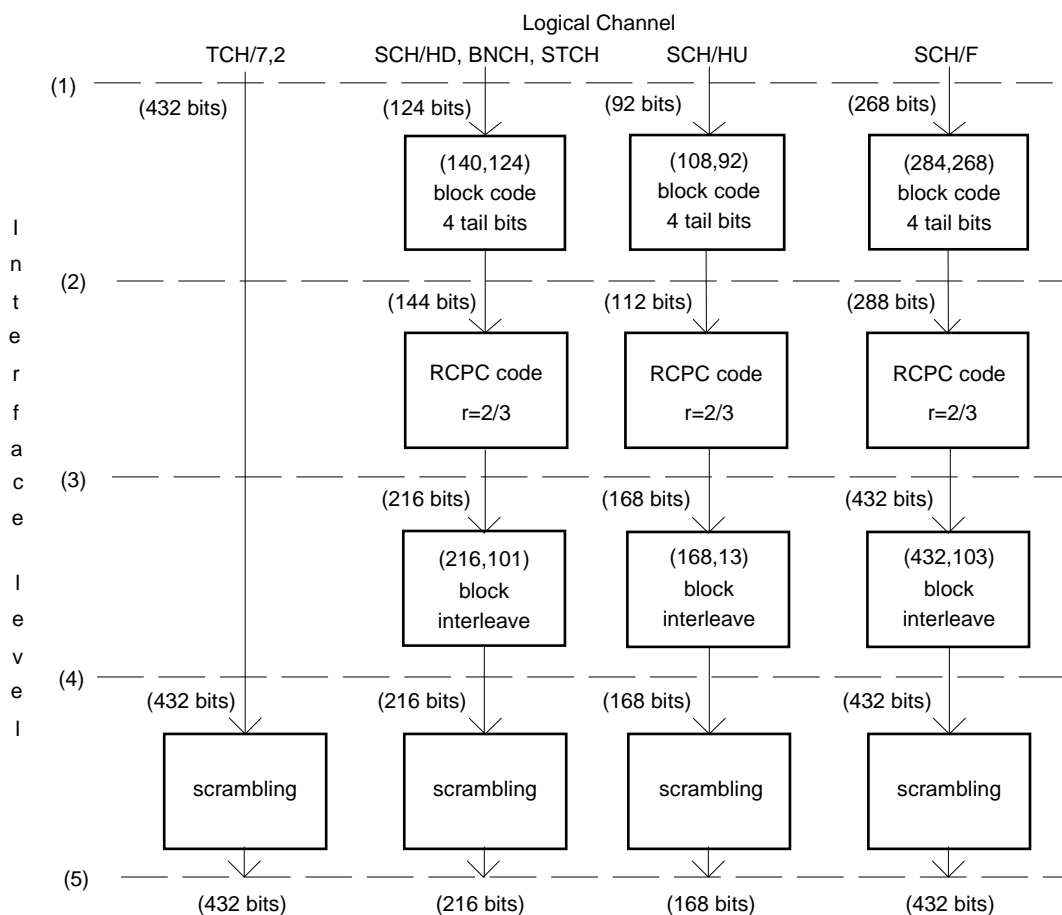


Figure 10: Error control structure for V+D logical channels (part 2)

### 8.3.1 Access Assignment Channel (AACH)

One type-1 block shall contain 14 type-1 bits  $b_1(1), b_1(2), \dots, b_1(14)$ .

A shortened (30,14) RM code (see clause 8.2.3.2) shall encode the 14 type-1 bits into 30 type-2 bits,  $b_2(1), b_2(2), \dots, b_2(30)$ .

The type-4 bits shall be the same as the type-2 bits:

$$b_4(k) = b_2(k) \quad \text{for } k = 1, 2, \dots, 30 \quad (45)$$

The 30 type-4 bits  $b_4(1), b_4(2), \dots, b_4(30)$ , compose the type-4 block for AACH. They shall be scrambled into bits  $b_5(1), b_5(2), \dots, b_5(30)$ , according to clause 8.2.5.1, with the scrambling sequence as defined in clause 8.2.5.2. The multiplexed bits of the BBK shall be defined as:

$$bb(k) = b_5(k), \quad \text{for } k = 1, 2, \dots, 30 \quad (46)$$

### 8.3.2 Broadcast Synchronization Channel (BSCH)

One type-1 block shall contain 60 type-1 bits  $b_1(1), b_1(2), \dots, b_1(60)$ .

A (76,60) block code shall encode the 60 type-1 bits into 76 block-encoded bits,  $b_2(1), b_2(2), \dots, b_2(76)$ . This code is the  $(K_I+16, K_I)$  block code as defined in clause 8.2.3.3, with  $K_I = 60$ .

Four tail bits,  $b_2(77), b_2(78), b_2(79), b_2(80)$ , all set equal to zero, shall be appended to the 76 block-encoded bits.

The resultant bits  $b_2(1), b_2(2), \dots, b_2(80)$  shall be the type-2 bits.

A 16-state RCPC code with rate 2/3 (see clause 8.2.3.1), shall encode the 80 type-2 bits into 120 type-3 bits,  $b_3(1), b_3(2), \dots, b_3(120)$ .

A (120, 11) block interleaving (see clause 8.2.4.1) shall re-order the 120 type-3 bits into 120 type-4 bits,  $b_4(1), b_4(2), \dots, b_4(120)$ .

The 120 type-4 bits,  $b_4(1), b_4(2), \dots, b_4(120)$  compose the type-4 block for BSCH. They shall be scrambled into bits  $b_5(1), b_5(2), \dots, b_5(120)$ , according to clause 8.2.5.1, with the scrambling sequence as defined in clause 8.2.5.2.

The multiplexed bits of the synchronization block shall be defined as:

$$sb(k) = b_5(k), \quad \text{for } k = 1, 2, \dots, 120 \quad (47)$$

### 8.3.3 Traffic channels in circuit switched mode

In case frame stealing is activated for one of the data traffic channels defined below the multiplexed bits either of block-1 or of block-1 and block-2 are replaced by STCH bits. This means that the bits are replaced after coding, interleaving and scrambling. The construction of STCH bits is defined in clause 8.3.4.1.

NOTE: Frame stealing on speech traffic channels modifies the type of logical channel which the speech channel encoder is using, refer to ETS 300 395-2 [40] clause 5 and see notes in clauses 8.3.3.4 and 8.3.3.5.

In the case of multi-slot transmission, up to four low bit rate traffic channels shall be multiplexed. This is further described in clause 23.

#### 8.3.3.1 Traffic CHannel, net rate = 4,8 kbit/s (TCH/4,8)

A sequence of  $M$  type-1 blocks,  $B_1(m)$ ,  $m = 1, 2, \dots, M$ , shall be transmitted, whereby  $M$  is not limited.

One type-1 block shall contain 288 type-1 bits,  $b_1(1), b_1(2), \dots, b_1(288)$ .

The  $K_2 = 292$  type-2 bits shall comprise the 288 type-1 bits mapped as follows:

$$b_2(j) = b_1(j), \quad \text{for } j = 1, 2, \dots, 288 \quad (48)$$

with the addition of four tail bits,  $b_2(289), b_2(290), b_2(291), b_2(292)$ , all set equal to zero.

A 16-state RCPC code with rate 292/432 (see clause 8.2.3.1) shall encode the 292 type-2 bits into 432 type-3 bits,  $b_3(1), b_3(2), \dots, b_3(432)$ .

An interleaving over  $N$  blocks (see clause 8.2.4.2) shall interleave bits from  $M$  type-3 blocks (of 432 bits each) into  $(M+N-1)$  type-4 blocks (of 432 bits each): the bits in one type-4 block shall be denoted by  $b_4(1), b_4(2), \dots, b_4(432)$ . The parameter  $N$  shall be pre-set at the call set-up, and may take the values 1, 4, or 8.

The 432 type-4 bits  $b_4(1), b_4(2), \dots, b_4(432)$  shall compose the type-4 block for TCH/4,8. They shall be scrambled into bits  $b_5(1), b_5(2), \dots, b_5(432)$ , according to clause 8.2.5.1, with the scrambling sequence as defined in clause 8.2.5.2.

The multiplexed bits of block-1 are defined as:

$$bkn1(k) = b_5(k), \quad \text{for } k = 1, 2, \dots, 216 \quad (49)$$

In case of frame stealing of block-1  $bkn1(1), bkn1(2), \dots, bkn1(216)$  shall be discarded, and replaced with the STCH bits as defined in 8.3.4.1 for block-1.

The multiplexed bits of block-2 are defined as:

$$bkn2(k) = b_5(k+216), \quad \text{for } k = 1, 2, \dots, 216 \quad (50)$$

In case of frame stealing of block-2,  $bkn2(1), bkn2(2), \dots, bkn2(216)$  shall be discarded, and replaced with the STCH bits as defined in clause 8.3.4.1 for block-2.

### 8.3.3.2 Traffic CHannel, net rate = 2,4 kbit/s (TCH/2,4)

A sequence of  $M$  type-1 blocks,  $B_I(m)$ ,  $m = 1, 2, \dots, M$ , shall be transmitted, whereby  $M$  is not limited.

One type-1 block shall contain 144 type-1 bits,  $b_1(1), b_1(2), \dots, b_1(144)$ .

The  $K_2 = 148$  type-2 bits shall comprise the 144 type-1 bits mapped as follows:

$$b_2(j) = b_1(j), \quad \text{for } j = 1, 2, \dots, 144 \quad (51)$$

with the addition of four tail bits,  $b_2(145), b_2(146), b_2(147), b_2(148)$ , all set equal to zero.

A 16-state RCPC code with rate 148/432 (see clause 8.2.3.1) encodes the 148 type-2 bits into 432 type-3 bits,  $b_3(1), b_3(2), \dots, b_3(432)$ .

An interleaving over  $N$  blocks (see clause 8.2.4.2) shall interleave bits from  $M$  type-3 blocks (of 432 bits each) into  $(M + N - 1)$  type-4 blocks (of 432 bits each): the bits in one type-4 block shall be denoted by  $b_4(1), b_4(2), \dots, b_4(432)$ . The parameter  $N$  shall be pre-set at the call set-up, and may take the values 1, 4 or 8.

The 432 type-4 bits  $b_4(1), b_4(2), \dots, b_4(432)$  shall compose the type-4 block for TCH/2,4. They shall be scrambled into bits  $b_5(1), b_5(2), \dots, b_5(432)$ , according to clause 8.2.5.1, with the scrambling sequence as defined in clause 8.2.5.2.

The multiplexed bits of block-1 are defined as:

$$bkn1(k) = b_5(k), \quad \text{for } k = 1, 2, \dots, 216 \quad (52)$$

In case of frame stealing of block-1  $bkn1(1), bkn1(2), \dots, bkn1(216)$  shall be discarded, and replaced with the STCH bits as defined in clause 8.3.4.1 for block-1.

The multiplexed bits of block-2 are defined as:

$$bkn2(k) = b_5(k+216), \quad \text{for } k = 1, 2, \dots, 216 \quad (53)$$

In case of frame stealing of block-2,  $bkn2(1), bkn2(2), \dots, bkn2(216)$  shall be discarded, and replaced with the STCH bits as defined in 8.3.4.1 for block-2.

### 8.3.3.3 Traffic CHannel, net rate = 7,2 kbit/s (TCH/7,2)

A sequence of  $M$  type-1 blocks,  $B_I(m)$ ,  $m = 1, 2, \dots, M$ , shall be transmitted, whereby  $M$  is not limited.

One type-1 block shall contain 432 type-1 bits,  $b_1(1), b_1(2), \dots, b_1(432)$ .

There shall be 432 type-4 bits, which are the same as the type-1 bits:

$$b_4(k) = b_1(k), \quad \text{for } k = 1, 2, \dots, 432 \quad (54)$$

The 432 type-4 bits  $b_4(1), b_4(2), \dots, b_4(432)$  shall compose the type-4 block for TCH/7,2. They shall be scrambled into bits  $b_5(1), b_5(2), \dots, b_5(432)$ , according to clause 8.2.5.1, with the scrambling sequence as defined in clause 8.2.5.2.

The multiplexed bits of block-1 shall be defined as:

$$bkn1(k) = b_5(k), \quad \text{for } k = 1, 2, \dots, 216 \quad (55)$$

In case of frame stealing of block-1  $bkn1(1), bkn1(2), \dots, bkn1(216)$  shall be discarded, and replaced with the STCH bits as defined in 8.3.4.1 for block-1.

The multiplexed bits of block-2 shall be defined as:

$$bkn2(k) = b_5(k+216), \quad \text{for } k = 1, 2, \dots, 216 \quad (56)$$

In case of frame stealing of block-2,  $bkn2(1), bkn2(2), \dots, bkn2(216)$  shall be discarded, and replaced with the STCH bits as defined in 8.3.4.1 for block-2.

### 8.3.3.4 Speech Traffic Channel, full slot (TCH/S)

ETS 300 395-2 [40] defines in clause 5.5.3 432 type-4 bits  $C_4(1), C_4(2), \dots, C_4(432)$ . For the purpose of scrambling those bits are mapped into  $b_4(k) = C_4(k)$  for  $k = 1, 2, \dots, 432$ . The  $b_4(1), b_4(2), \dots, b_4(432)$  bits shall be scrambled into bits  $b_5(1), b_5(2), \dots, b_5(432)$ , according to clause 8.2.5.1, with the scrambling sequence as defined in clause 8.2.5.2.

The multiplexed bits of block-1 shall be defined as:

$$bkn1(k) = b_5(k), \quad \text{for } k = 1, 2, \dots, 216$$

and the multiplexed bits of block-2 shall be defined as:

$$bkn2(k) = b_5(k + 216), \quad \text{for } k = 1, 2, \dots, 216$$

NOTE: It is considered that the MS is not stealing from a full slot speech channel but the MAC first informs the speech channel encoder which discards the type-1 bits of speech frame A and then uses half slot speech channel encoding for the type-1 bits of speech frame B.

### 8.3.3.5 Speech Traffic Channel, half slot (TCH/S)

ETS 300 395-2 [40] defines in clauses 5.4.3.2, 5.6.2 and 5.6.2.1 216 type-3 bits  $C_3(1), C_3(2), \dots, C_3(216)$ . For the purpose of further processing those bits are mapped into  $b_3(k) = C_3(k)$  for  $k = 1, 2, \dots, 216$ .

As specified in ETS 300 395-2 [40] clause 5.6.3, a (216, 101) block interleaver (see clause 8.2.4.1) shall re-order the 216 type-3 bits  $b_3(1), b_3(2), \dots, b_3(216)$ , into 216 type-4 bits,  $b_4(1), b_4(2), \dots, b_4(216)$ .

The 216 type-4 bits  $b_4(1), b_4(2), \dots, b_4(216)$  shall compose the type-4 block for the half slot speech channel. They shall be scrambled into bits  $b_5(1), b_5(2), \dots, b_5(216)$ , according to clause 8.2.5.1, with the scrambling sequence as defined in clause 8.2.5.2.

The multiplexed bits of block-2 shall be defined as:

$$bkn2(k) = b_5(k), \quad \text{for } k = 1, 2, \dots, 216 \quad (56A)$$

NOTE: The MAC does not use block-1 for half slot speech transmission.

## 8.3.4 Signalling channels for signalling and packet mode data

### 8.3.4.1 Signalling CHannel for mapping onto Half-bursts on the Downlink (SCH/HD), Broadcast Network CHannel (BNCH), and STealing CHannel (STCH)

One type-1 block shall contain 124 type-1 bits,  $b_1(1), b_1(2), \dots, b_1(124)$ .

A (140,124) block code shall encode the 124 type-1 bits into 140 block-encoded bits  $b_2(1), b_2(2), \dots, b_2(140)$ . This code shall be the  $(K_I+16, K_I)$  block code as defined in clause 8.2.3.3, with  $K_I = 124$ .

Four tail bits,  $b_2(141), b_2(142), b_2(143), b_2(144)$ , all set equal to zero, shall be appended to the 140 block-encoded bits.

The resultant bits  $b_2(1), b_2(2), \dots, b_2(144)$  shall be the type-2 bits.

A 16-state RCPC code with rate 2/3 (see clause 8.2.3.1) shall encode the 144 type-2 bits into 216 type-3 bits,  $b_3(1), b_3(2), \dots, b_3(216)$ .

A (216,101) block interleaver (see clause 8.2.4.1) shall re-order the 216 type-3 bits into 216 type-4 bits,  $b_4(1), b_4(2), \dots, b_4(216)$ .

The 216 type-4 bits  $b_4(1), b_4(2), \dots, b_4(216)$  shall compose the type-4 block for SCH/HD, BNCH, and STCH. They shall be scrambled into bits  $b_5(1), b_5(2), \dots, b_5(216)$ , according to clause 8.2.5.1, with the scrambling sequence as defined in clause 8.2.5.2.

The type-5 bits may be multiplexed onto block-1, in which case the multiplexed bits are defined as:

$$bkn1(k) = b_5(k), \quad \text{for } k = 1, 2, \dots, 216 \quad (57)$$

or they may be multiplexed into block-2, in which case the multiplexed bits shall be defined as:

$$bkn2(k) = b_5(k), \quad \text{for } k = 1, 2, \dots, 216 \quad (58)$$

### 8.3.4.2 Signalling CHannel for mapping onto Half-bursts on the Uplink (SCH/HU)

One type-1 block shall contain 92 type-1 bits  $b_1(1), b_1(2), \dots, b_1(92)$ .

A (108,92) block code shall encode the 92 type-1 bits into 108 block-encoded bits,  $b_2(1), b_2(2), \dots, b_2(108)$ . This code is the  $(K_I+16, K_I)$  block code as defined in clause 8.2.3.3, with  $K_I = 92$ .

Four tail bits,  $b_2(109), b_2(110), b_2(111), b_2(112)$ , all set equal to zero, shall be appended to the 108 block-encoded bits.

The resultant bits  $b_2(1), b_2(2), \dots, b_2(112)$  shall be the type-2 bits.

A 16-state RCPC code with rate 2/3 (see clause 8.2.3.1) shall encode the 112 type-2 bits into 168 type-3 bits,  $b_3(1), b_3(2), \dots, b_3(168)$ .

A (168, 13) block interleaver (see clause 8.2.4.1) shall re-order the 168 type-3 bits into 168 type-4 bits,  $b_4(1), b_4(2), \dots, b_4(168)$ .

The 168 type-4 bits  $b_4(1), b_4(2), \dots, b_4(168)$  shall compose the type-4 block for SCH/HU. They shall be scrambled into bits  $b_5(1), b_5(2), \dots, b_5(168)$ , according to clause 8.2.5.1, with the scrambling sequence as defined in clause 8.2.5.2.

The multiplexed bits of the control block (which is the type-5 block for SCH/HU) are defined as:

$$cb(k) = b_5(k), \quad \text{for } k = 1, 2, \dots, 168 \quad (59)$$

### 8.3.4.3 Signalling CHannel for mapping onto Full bursts (SCH/F)

One type-1 block shall contain 268 type-1 bits,  $b_1(1), b_1(2), \dots, b_1(268)$ .

A (284,268) block code shall encode the 268 type-1 bits into 284 block-encoded bits  $b_2(1), b_2(2), \dots, b_2(284)$ . This code shall be the  $(K_I+16, K_I)$  block code as defined in clause 8.2.3.3, with  $K_I = 268$ .

Four tail bits,  $b_2(285), b_2(286), b_2(287), b_2(288)$ , all set equal to zero, shall be appended to the 284 block-encoded bits.

The resultant bits  $b_2(1), b_2(2), \dots, b_2(288)$  shall be the type-2 bits.

A 16-state RCPC code with rate 2/3 (see clause 8.2.3.1) encodes the 288 type-2 bits into 432 type-3 bits,  $b_3(1), b_3(2), \dots, b_3(432)$ .

A (432,103) block interleaver (see clause 8.2.4.1) shall re-order the 432 type-3 bits into 432 type-4 bits,  $b_4(1), b_4(2), \dots, b_4(432)$ .

The 432 type-4 bits  $b_4(1), b_4(2), \dots, b_4(432)$  shall compose the type-4 block for SCH/F. They shall be scrambled into bits  $b_5(1), b_5(2), \dots, b_5(432)$ , according to clause 8.2.5.1, with the scrambling sequence as defined in clause 8.2.5.2.

The multiplexed bits of block-1 are defined as:

$$bkn1(k) = b_5(k), \quad \text{for } k = 1, 2, \dots, 216 \quad (60)$$

and the multiplexed bits of block 2 are defined as:

$$bkn2(k) = b_5(k+216), \quad \text{for } k = 1, 2, \dots, 216 \quad (61)$$

---

## 9 Channel multiplexing for V+D

### 9.1 Introduction

This clause defines the physical channels of the V+D radio sub-system required to support the logical channels. It includes a description of the logical channels and the definitions of TDMA frames, timeslots and bursts.

### 9.2 Logical channels

A logical channel is defined as a logical communication pathway between two or more parties. The logical channels represent the interface between the protocol and the radio subsystem.

The definition of the logical channels that are supported by the radio subsystem is given below.

#### 9.2.1 Logical channels hierarchy

The logical channels may be separated into two categories: the traffic channels carrying speech or data information in circuit switched mode and the control channels carrying signalling messages and packet data. The logical channels supported by the MAC are described here, with their hierarchical relationship.

#### 9.2.2 Traffic channels

The traffic channels shall carry user information. Different traffic channels are defined for speech or data applications and for different data message speeds:

- Speech Traffic Channel (TCH/S);
- Circuit mode traffic channels as follows:
  - 7,2 kbit/s net rate (TCH/7.2);
  - 4,8 kbit/s net rate (TCH/4.8);
  - 2,4 kbit/s net rate (TCH/2.4).

Higher net rate up to 28,8 kbit/s, 19,2 kbit/s or 9,6 kbit/s may be used. They are obtained by allocating up to 4 TP channels to the same communication.

NOTE: Three different depths of interleaving (with  $N = 1, 4, \text{ or } 8$ ) may be applied to the traffic channels TCH/4.8 and TCH/2.4 as detailed in clause 8.2.4.2.

#### 9.2.3 Control CHannels (CCH)

##### 9.2.3.1 General

The CCH shall carry signalling messages and packet data. Five categories of control channel are defined:

- Broadcast Control CHannel (BCCH);
- Linearization CHannel (LCH);
- Signalling CHannel (SCH);
- Access Assignment CHannel (AACH); and
- STealing CHannel (STCH).

### 9.2.3.2 BCCH

The BCCH shall be a uni-directional channel for common use by all MSs. It shall broadcast general information to all MSs.

Two categories of BCCHs are defined, network and synchronization:

- Broadcast Network Channel (BNCH):
  - down-link only, broadcasts network information to MSs.
- Broadcast Synchronization Channel (BSCH):
  - down-link only, broadcast information used for time and scrambling synchronization of the MSs.

### 9.2.3.3 LCH

The LCH shall be used by the base and MSs to linearize their transmitter.

Two categories of LCHs are defined, common and BS:

- Common Linearization Channel (CLCH):
  - up-link, shared by all the MSs;
- BS Linearization CHannel (BLCH):
  - downlink, used by the BS.

### 9.2.3.4 SCH

The SCH shall be shared by all MSs, but may carry messages specific to one or one group of MSs. System operation requires the establishment of at least one SCH per BS. SCH may be divided into 3 categories, depending on the size of the message:

- Full size Signalling Channel (SCH/F):
  - bidirectional channel used for full size messages.
- Half size Downlink Signalling Channel (SCH/HD):
  - downlink only, used for half size messages.
- Half size Uplink Signalling Channel (SCH/HU):
  - uplink only, used for half size messages.

### 9.2.3.5 AACH

The AACH shall be present on all transmitted downlink slots. It shall be used to indicate on each physical channel the assignment of the uplink and downlink slots. The AACH shall be internal to the MAC.

### 9.2.3.6 STCH

The STCH is a channel associated to a TCH that temporarily "steals" a part of the associated TCH capacity to transmit control messages. It may be used when fast signalling is required. In half duplex mode the STCH is unidirectional and has the same direction as the associated TCH.

## 9.3 The physical resource

### 9.3.1 General

The physical resource available to the radio sub-system is an allocation of part of the radio spectrum. This resource shall be partitioned both in frequency and time. Frequency shall be partitioned by RF channels divided into bands as defined in clause 6. Time shall be partitioned by timeslots and TDMA frames as defined in this clause.

The access scheme shall be TDMA.

The TDMA structure shall be composed of hyperframes, multiframes, frames, slots and subslots. Figure 11 repeats the representation of the TDMA structure given in figure 2.

### 9.3.2 RF channels

A RF channel is defined as a specified portion of the RF spectrum. Clause 6 defines the carrier separation which applies to TETRA channels.

The DownLink (DL) comprises RF channels used in the BS to MS direction.

The UpLink (UL) comprises RF channels used in the MS to BS direction.

One pair of radio frequencies (uplink and downlink) of the cell allocation shall be used to carry the MCCH (see clauses 9.4.2.1 and 9.5.1) and shall be known as the main carrier.

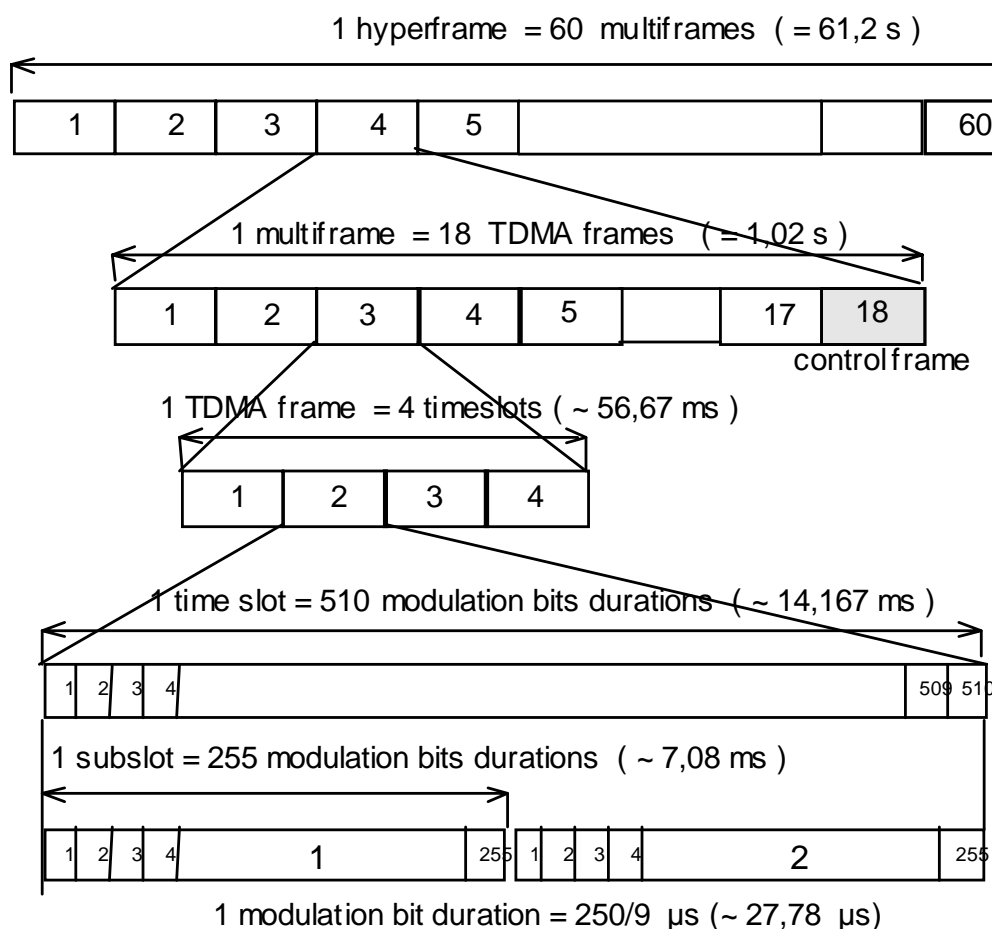


Figure 11: TDMA structure



### 9.3.3 Timeslots

The basic unit of the TDMA structure is the timeslot. A timeslot shall have a duration of  $8\frac{5}{6}$  ms (approximately 14,17 ms) which corresponds to 510 modulation bits duration.

### 9.3.4 TDMA frame

Four timeslots shall form a TDMA frame. The TDMA frame has a duration of  $170\frac{2}{3}$  ms (approximately 56,67 ms).

The TDMA frames shall be numbered by a Frame Number (FN). The FN shall be cyclically numbered from 1 to 18. The FN shall be incremented at the end of each TDMA frame.

The frame FN18 (also termed the control frame) shall be exclusively devoted to control channels.

### 9.3.5 Timeslot numbering

The timeslots within a TDMA frame shall be numbered from 1 to 4 and a particular timeslot shall be referenced by its Timeslot Number (TN).

### 9.3.6 Subslot

The uplink timeslots may be divided into 2 subslots. The subslots within a timeslot shall be numbered from 1 to 2 and a particular subslot shall be referenced by its SubSlot Number (SSN).

A subslot shall have a duration of  $85\frac{1}{2}$  ms (approximately 7,08 ms) which corresponds to 255 modulation bits duration.

### 9.3.7 Multiframe

Eighteen TDMA frames shall form a multiframe. The multiframe shall have a duration of 1,02 s.

The multiframes shall be numbered by a Multiframe Number (MN). The MN shall be cyclically numbered from 1 to 60. The MN shall be incremented whenever the TDMA FN returns to 1.

### 9.3.8 Hyperframe

The hyperframe shall be the longest recurrent time period of the TDMA structure. Sixty multiframes shall form a hyperframe. The hyperframe shall have a duration of 61,2 s.

### 9.3.9 Frame alignment

At the BS, the start of the hyperframe, multiframe and TDMA frame on the uplink shall be delayed by the fixed period of 2 timeslots from the start of the hyperframe, multiframe and TDMA frame on the downlink.

## 9.4 Physical channels

### 9.4.1 General

A physical channel is defined by a pair of radio carrier frequencies (downlink and uplink) and a TN. There shall be 4 physical channels per pair of radio frequencies.

## 9.4.2 Types of physical channels

Three types of physical channel are defined:

- the Control Physical channel (CP);
- the Traffic Physical channel (TP); and
- the Unallocated Physical channel (UP).

The type of physical channel shall be indicated in the AACH.

### 9.4.2.1 CP channel

The CP channel is a physical channel carrying exclusively CCH. Two types of CP channels are defined:

- the Main Control CHannel (MCCH); and
- the Secondary Control CHannel (SCCH).

In each cell one RF carrier shall be defined as the main carrier. Whenever a MCCH is used, the MCCH shall be located on the timeslot 1 of the main carrier.

The SCCH may be used to extend the signalling capacity of the MCCH and may only be assigned when the MCCH is used.

### 9.4.2.2 TP channel

The TP channel is a physical channel carrying TCH.

### 9.4.2.3 UP channel

The UP channel is a physical channel not allocated to one or more MS.

## 9.4.3 Bursts

### 9.4.3.1 General

A burst is a period of RF carrier that is modulated by a data stream. A burst, therefore, represents the physical content of a timeslot or subslot.

The description of a physical channel will be made in terms of timeslots and TDMA frames and not in terms of bursts. This is because there is not a one-to-one mapping between a particular physical channel and the use of a particular burst.

A given physical channel shall use the same timeslot number in every TDMA frame.

### 9.4.3.2 Modulation symbol numbering

A timeslot shall be divided into 255 modulation symbol durations, each one with a duration of 1/18 ms (approximately 55,56  $\mu$ s). A particular modulation symbol within a burst shall be referenced by a Symbol Number (*SN*), with the first modulation symbol numbered *SN<sub>I</sub>* and the last modulation symbol numbered *SN<sub>max</sub>*.

Different types of bursts are defined, having different durations.

At the beginning of the transmission of a single burst or of consecutive bursts, a supplementary symbol *SN<sub>0</sub>* is defined. It does not carry information but shall be used as phase reference for the differential modulation.

### 9.4.3.3 Modulation bit numbering

In the following clauses the content of the burst is defined in terms of modulation bits.

A particular modulation bit within a burst shall be referenced by a Bit Number ( $BN$ ), with the first modulation bit numbered  $BN1$  and the last modulation bit numbered  $BNmax$ . At the modulator the modulation bits shall be grouped in pairs of consecutive odd and even numbered bits and each pair shall be converted into one modulation symbol as described in clause 5.

### 9.4.3.4 Burst timing

The symbol time is defined as the instant at which the transmitted symbol waveform is at a maximum for the symbol of interest. The timing of a modulation symbol is determined by its symbol time.

The bits  $BN(2n-1)$  and  $BN(2n)$  shall determine the symbol  $SN(n)$  and the symbol time of the modulation symbol  $SN(n)$  shall be delayed by  $(n+d)$  modulation symbol durations with respect to the start of the slot, with:

- $n$ : integer (1 ... ( $SNmax$ ));
- $d$ : is defined as the burst delay. The burst delay represents the delay between the start of the timeslot and the symbol time of the symbol  $SN0$ . The burst delay shall be expressed in modulation symbol duration and varies with the type of burst and the SSN. The values of the burst delays are given in table 18.

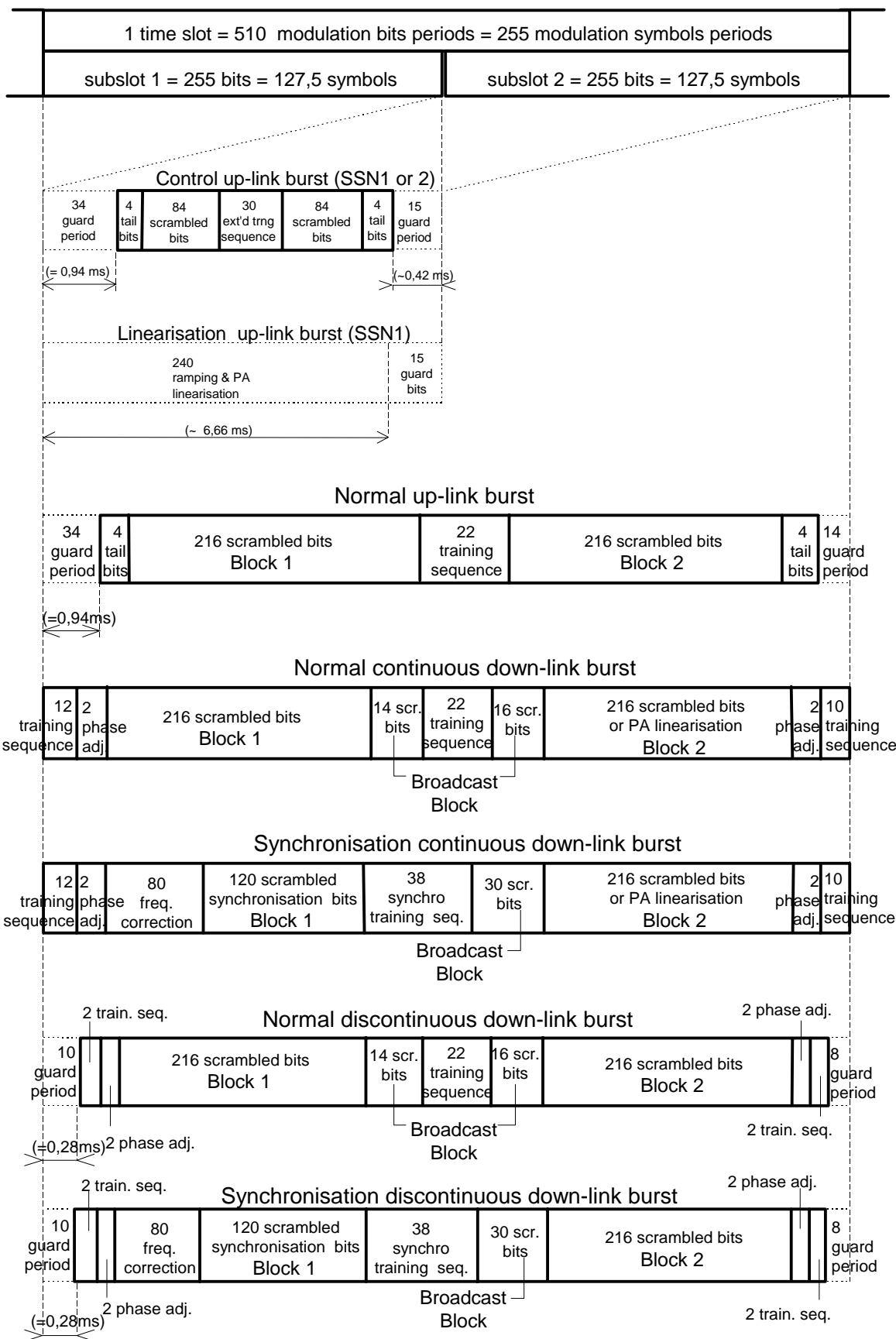
NOTE: Symbol time of the symbol  $SN0$  is same as symbol time of the symbol  $SN255$  of the previous slot.

The symbol time of the symbol  $SN0$  occurs one modulation symbol duration before the symbol time of the symbol  $SN1$  of the first burst of a transmission.

## 9.4.4 Type of bursts

### 9.4.4.1 General

Eight types of bursts shall exist in the system. Figure 12 summarizes the description of the bursts and their timing with respect to the timeslot.



**Figure 12: Types of bursts**

NOTE: The power-time mask is defined in clause 6, figure 7 and table 7. The  $t_1$  period defined in clause 6, table 7 may be used for ramping and PA linearization.

Table 18: Burst types

Burst type	SNmax	d burst delay (in symbol duration)		Bit allocation
		SSN 1	SSN 2	
control uplink	103	17	144,5	see clause 9.4.4.2.1
linearization uplink	not applicable	120	not allowed	see clause 9.4.4.2.2
linearization downlink	not applicable	not allowed	not applicable	see clause 9.4.4.2.3
normal uplink	231	17		see clause 9.4.4.2.4
normal continuous downlink	255	0		see clause 9.4.4.2.5
synchronization continuous downlink	255	0		see clause 9.4.4.2.6
normal discontinuous downlink	246	5		see clause 9.4.4.2.7
synchronization discontinuous downlink	246	5		see clause 9.4.4.2.8

The generic name for normal continuous and discontinuous downlink burst is Normal Downlink Burst (NDB). The generic name for synchronization continuous and discontinuous downlink burst is Synchronization downlink Burst (SB).

#### 9.4.4.2 Modulation bits allocation

The bursts are divided into burst fields containing contiguous modulation bits of the same type. The burst fields are described in clause 9.4.4.3.

The downlink bursts contain 3 independent blocks, called Broadcast Block (BBK), Block 1 (*BKN1*) and Block 2 (*BKN2*). The normal uplink bursts contains two independent blocks, called Block 1 (*BKN1*) and Block 2 (*BKN2*). A separate logical channel may be mapped on each block. The broadcast block shall be made of the two scrambled broadcast bits fields and shall contain 30 bits. The block 1 and block 2 shall be made of one field and shall contain 216 scrambled bits. In the case of synchronization bursts, block 1 contains 120 bits.

##### 9.4.4.2.1 Control uplink Burst (CB)

The allocation of the modulation bits in the CB shall be in accordance with table 19. The CB shall be used by MS to transmit control messages to the BS.

Table 19: Control uplink Burst (CB)

Bit Number (BN)	Field length (bits)	Field content	Field bits number	Definition
1 to 4	4	tail bits	<i>t1</i> to <i>t4</i>	see clause 9.4.4.3.5
5 to 88	84	scrambled control bits	<i>cb(1)</i> to <i>cb(84)</i>	see clause 8
89 to 118	30	extended training sequence	<i>x1</i> to <i>x30</i>	see clause 9.4.4.3.3
119 to 202	84	scrambled control bits	<i>cb(85)</i> to <i>cb(168)</i>	see clause 8
203 to 206	4	tail bits	<i>t1</i> to <i>t4</i>	see clause 9.4.4.3.5

##### 9.4.4.2.2 Linearization uplink Burst (LB)

The LB may be used by the MSs to linearize their transmitters. The LB contains no useful bits and its timing shall only be determined by the time mask (see clause 6).

##### 9.4.4.2.3 Linearization downlink burst

The linearization downlink burst replaces BKN2 of either a normal continuous downlink burst or a synchronization continuous downlink burst.

The linearization downlink burst may be used by the BS to linearize its transmitter. The linearization downlink burst contains non useful bits and its timing shall be determined only by the time mask (see clause 6).

#### 9.4.4.2.4 Normal Uplink Burst (NUB)

The allocation of the modulation bits in the NUB shall be in accordance with table 20. The NUB shall be used by MSs to transmit control or traffic messages to the BS.

**Table 20: Normal Uplink Burst (NUB)**

Bit Number (BN)	Field length (bits)	Field content	Field bits number	Definition
1 to 4	4	tail bits	<i>t1 to t4</i>	see clause 9.4.4.3.5
5 to 220	216	scrambled block 1 bits	<i>bkn1(1) to bkn1(216)</i>	see clause 8
221 to 242	22	normal training sequence	<i>n1 to n22 or p1 to p22</i>	see clause 9.4.4.3.2
243 to 458	216	scrambled block 2 bits	<i>bkn2(1) to bkn2(216)</i>	see clause 8
459 to 462	4	tail bits	<i>t1 to t4</i>	see clause 9.4.4.3.5

#### 9.4.4.2.5 Normal continuous downlink burst

The allocation of the modulation bits in the normal continuous downlink burst shall be in accordance with table 21. The normal continuous downlink burst shall be used by the BS in continuous transmission mode to transmit control or traffic messages to the MS.

**Table 21: Normal continuous downlink burst**

Bit Number (BN)	Field length (bits)	Field content	Field bits number	Definition
1 to 12	12	normal training sequence 3	<i>q11 to q22</i>	see clause 9.4.4.3.2
13 to 14	2	phase adjustment bits	<i>ha1 to ha2</i>	see clause 9.4.4.3.6
15 to 230	216	scrambled block 1 bits	<i>bkn1(1) to bkn1(216)</i>	see clause 8
231 to 244	14	scrambled broadcast bits	<i>bb(1) to bb(14)</i>	see clause 8
245 to 266	22	normal training sequence	<i>n1 to n22 or p1 to p22</i>	see clause 9.4.4.3.2
267 to 282	16	scrambled broadcast bits	<i>bb(15) to bb(30)</i>	see clause 8
283 to 498	216	scrambled block 2 bits	<i>bkn2(1) to bkn2(216)</i>	see clause 8
499 to 500	2	phase adjustment bits	<i>hb1 to hb2</i>	see clause 9.4.4.3.6
501 to 510	10	normal training sequence 3	<i>q1 to q10</i>	see clause 9.4.4.3.2

#### 9.4.4.2.6 Synchronization continuous downlink burst

The allocation of the modulation bits in the synchronization continuous downlink burst shall be in accordance with table 22. The synchronization continuous downlink burst shall be used by BSs in continuous transmission mode to broadcast synchronization messages and to transmit control messages to the MSs.

**Table 22: Synchronization continuous downlink burst**

Bit Number (BN)	Field length (bits)	Field content	Field bits number	Definition
1 to 12	12	normal training sequence 3	<i>q11 to q22</i>	see clause 9.4.4.3.2
13 to 14	2	phase adjustment bits	<i>hc1 to hc2</i>	see clause 9.4.4.3.6
15 to 94	80	frequency correction	<i>f1 to f80</i>	see clause 9.4.4.3.1
95 to 214	120	scrambled synchronization block 1 bits	<i>sb(1) to sb(120)</i>	see clause 8
215 to 252	38	synchronization training sequence	<i>y1 to y38</i>	see clause 9.4.4.3.4
253 to 282	30	scrambled broadcast bits	<i>bb(1) to bb(30)</i>	see clause 8
283 to 498	216	scrambled block 2 bits	<i>bkn2(1) to bkn2(216)</i>	see clause 8
499 to 500	2	phase adjustment bits	<i>hd1 to hd2</i>	see clause 9.4.4.3.6
501 to 510	10	normal training sequence 3	<i>q1 to q10</i>	see clause 9.4.4.3.2

#### 9.4.4.2.7 Normal discontinuous downlink burst

The allocation of the modulation bits in the normal discontinuous downlink burst shall be in accordance with table 23. The normal discontinuous downlink burst shall be used by BS in timesharing transmission mode to transmit control or traffic messages to the MS.

**Table 23: Normal discontinuous downlink burst**

Bit Number (BN)	Field length (bits)	Field content	Field bits number	Definition
1 to 2	2	normal training sequence 3	$q21$ to $q22$	see clause 9.4.4.3.2
3 to 4	2	phase adjustment bits	$hg1$ to $hg2$	see clause 9.4.4.3.6
5 to 220	216	scrambled block 1 bits	$bkn1(1)$ to $bkn1(216)$	see clause 8
221 to 234	14	scrambled broadcast bits	$bb(1)$ to $bb(14)$	see clause 8
235 to 256	22	normal training sequence	$n1$ to $n22$ or $p1$ to $p22$	see clause 9.4.4.3.2
257 to 272	16	scrambled broadcast bits	$bb(15)$ to $bb(30)$	see clause 8
273 to 488	216	scrambled block 2 bits	$bkn2(1)$ to $bkn2(216)$	see clause 8
489 to 490	2	phase adjustment bits	$hh1$ to $hh2$	see clause 9.4.4.3.6
491 to 492	2	normal training sequence 3	$q1$ to $q2$	see clause 9.4.4.3.2

#### 9.4.4.2.8 Synchronization discontinuous downlink burst

The allocation of the modulation bits in the synchronization discontinuous downlink burst shall be in accordance with table 24. The synchronization discontinuous downlink burst shall be used by the BS in timesharing transmission mode to broadcast synchronization messages and to transmit control messages to the MS.

**Table 24: Synchronization discontinuous downlink burst**

Bit Number (BN)	Field length (bits)	Field content	Field bits number	Definition
1 to 2	2	normal training sequence 3	$q21$ to $q22$	see clause 9.4.4.3.2
3 to 4	2	phase adjustment bits	$hi1$ to $hi2$	see clause 9.4.4.3.6
5 to 84	80	frequency correction	$f1$ to $f80$	see clause 9.4.4.3.1
85 to 204	120	scrambled synchronization block 1 bits	$sb(1)$ to $sb(120)$	see clause 8
205 to 242	38	synchronization training sequence	$y1$ to $y38$	see clause 9.4.4.3.4
243 to 272	30	scrambled broadcast bits	$bb(1)$ to $bb(30)$	see clause 8
273 to 488	216	scrambled block 2 bits	$bkn2(1)$ to $bkn2(216)$	see clause 8
489 to 490	2	phase adjustment bits	$hj1$ to $hj2$	see clause 9.4.4.3.6
491 to 492	2	normal training sequence 3	$q1$ to $q2$	see clause 9.4.4.3.2

#### 9.4.4.3 Burst fields

##### 9.4.4.3.1 Frequency correction field

The frequency correction field shall contain 80 bits:

$$(f1, f2, \dots, f8) = (1, 1, \dots, 1) \quad (62)$$

$$(f9, f10, \dots, f72) = (0, 0, \dots, 0) \quad (63)$$

$$(f73, f74, \dots, f80) = (1, 1, \dots, 1) \quad (64)$$

The frequency correction field generates an un-modulated carrier at 2,25 kHz above the nominal carrier frequency, preceded and followed by a short period (4 symbol durations) of un-modulated carrier at 6,75 kHz below the nominal carrier frequency.

### 9.4.4.3.2 Normal training sequence

Three 22 bit normal training sequences are defined.

The first two normal training sequences shall be used on the normal uplink and downlink bursts. The type of training sequence shall be used as a flag indicating the presence of one or two logical channels on the blocks 1 and 2 of the burst, according to table 25.

**Table 25: Training sequence mapping to logical channels**

Normal training sequence	Logical channel
1	TCH SCH/F
2	STCH + TCH STCH + STCH SCH/HD + SCH/HD SCH/HD + BNCH

The third training sequence shall be a supplementary training sequence spread over two consecutive downlink burst.

The normal training sequence 1 shall be:

$$(n1, n2, \dots, n22) = (1,1, 0,1, 0,0, 0,0, 1,1, 1,0, 1,0, 0,1, 1,1, 0,1, 0,0) \quad (65)$$

The normal training sequence 2 shall be:

$$(p1, p2, \dots, p22) = (0,1, 1,1, 1,0, 1,0, 0,1, 0,0, 0,0, 1,1, 0,1, 1,1, 1,0) \quad (66)$$

The normal training sequence 3 shall be:

$$(q1, q2, \dots, q22) = (1,0, 1,1, 0,1, 1,1, 0,0, 0,0, 0,1, 1,0, 1,0, 1,1, 0,1) \quad (67)$$

### 9.4.4.3.3 Extended training sequence

The extended training sequence shall be a 30 bit synchronization word used for the uplink control burst.

The extended training sequence shall be:

$$(x1, x2, \dots, x30) = (1,0, 0,1, 1,1, 0,1, 0,0, 0,0, 1,1, 1,0, 1,0, 0,1, 1,1, 0,1, 0,0, 0,0, 1,1) \quad (68)$$

### 9.4.4.3.4 Synchronization training sequence

The synchronization training sequence shall be a 38 bit synchronization word used for the synchronization downlink burst.

The synchronization training sequence shall be:

$$(y1, y2, \dots, y38) = (1,1, 0,0, 0,0, 0,1, 1,0, 0,1, 1,1, 0,0, 1,1, 1,0, 1,0, 0,1, 1,1, 0,0, 0,0, 0,1, 1,0, 0,1, 1,1) \quad (69)$$

### 9.4.4.3.5 Tail bits

The tail bit field shall contain 4 bits used for reducing the effect of filter transient response at the beginning and end of the bursts and for equalization purposes.

The contents of the tail bit field shall be:

$$(t1, t2, t3, t4) = (1, 1, 0, 0) \quad (70)$$



### 9.4.4.3.6 Phase adjustment bits

The phase adjustment bits shall be used on bursts defined in clauses 9.4.4.2 and 9.4.5.3 to provide a known phase relationship between the different training sequences of the burst, whatever is the content of the blocks.

The value of the pair of phase adjustment bits shall be set so that the phase shift  $D\phi$  they generate (see clause 5) is equal to:

$$D\phi = - \sum_{n=n1}^{n2} D\phi(n) \quad (71)$$

Where  $D\phi(n)$  is the phase transition generated by the bits  $(BN(2n-1), BN(2n))$ ,  $n1$  and  $n2$  are given by table 26.

**Table 26: Phase adjustment bits**

phase adjustment bits	$n1$	$n2$
$(ha1, ha2)$	8	122
$(hb1, hb2)$	123	249
$(hc1, hc2)$	8	108
$(hd1, hd2)$	109	249
$(he1, he2)$	112	230, see note
$(hf1, hf2)$	1	111
$(hg1, hg2)$	3	117
$(hh1, hh2)$	118	244
$(hi1, hi2)$	3	103
$(hj1, hj2)$	104	244
NOTE:	The $n2$ value 230 do not include the second symbol of the tail in the phase balance causing a non-zero phase change.	

## 9.4.5 Transmission modes

### 9.4.5.1 BS continuous transmission

When the BS is in continuous transmission mode normal downlink bursts or synchronization bursts shall be transmitted on all unused downlink slots of the main carrier and may be transmitted on the unallocated physical channels of the other carriers.

On the main carrier the BS shall only be allowed to ramp down and up during a BLCH. On the other carriers the BS may ramp down and up during the slots of an UP channel.

The first burst after ramp up of a D-CT shall be preceded by a start burst ( $SN_{max} = 5$ ), according to table 27.

**Table 27: Start burst**

Bit Number (BN)	Field length (bits)	Field content	Field bits number	Definition
1 to 10	10	normal training sequence 3	$q1$ to $q10$	clause 9.4.4.3.2

The last burst before ramp down of a D-CT shall be followed by a stop burst ( $SN_{max} = 6$ ), according to table 28.

**Table 28: Stop burst**

Bit Number (BN)	Field length (bits)	field content	field bits number	definition
1 to 12	12	normal training sequence 3	$q11$ to $q22$	clause 9.4.4.3.2

### 9.4.5.2 BS timesharing transmission

The BS in timesharing transmission mode need not to ramp down and up between adjacent discontinuous downlink bursts. In the case where the BS does not perform the ramping, the discontinuous burst shall be followed by 8 bits (corresponding to the guard period) according to table 29, and the subsequent burst shall be preceded by 10 bits (corresponding to the ramp up and linearization period) according to table 30.

**Table 29: Bits following the burst**

Bit number	Field length (bits)	Field content	Field bits number	Definition
1 to 8	8	normal training sequence 3	$q3$ to $q10$	clause 9.4.4.3.2

**Table 30: Bits preceding the burst**

Bit number	Field length (bits)	Field content	Field bits number	Definition
1 to 10	10	normal training sequence 3	$q11$ to $q20$	clause 9.4.4.3.2

### 9.4.5.3 MS multiple slot transmission

The MS transmitting on more than 1 physical channel need not to ramp down and up between adjacent normal uplink bursts. In the case where the MS does not perform the ramping, the burst shall be followed by 14 bits (corresponding to the guard period) defined in table 31 and the subsequent burst shall be preceded by 34 bits (corresponding to the ramp up and linearization period), according table 32.

**Table 31: Bits following the burst**

Bit number	Field length (bits)	Field content	Field bits number	Definition
1 to 2	2	phase adjustment bits	$he1$ to $he2$	clause 9.4.4.3.6
3 to 4	2	tail bits	$t1$ to $t2$	clause 9.4.4.3.5
5 to 14	10	normal training sequence 3	$q1$ to $q10$	clause 9.4.4.3.2

**Table 32: Bits preceding the burst**

Bit number	Field length (bits)	Field content	Field bits number	Definition
1 to 30	30	extended training sequence	$x1$ to $x30$	clause 9.4.4.3.3
31 to 32	2	tail bits	$t3$ to $t4$	clause 9.4.4.3.5
33 to 34	2	phase adjustment bits	$hf1$ to $hf2$	clause 9.4.4.3.6

## 9.5 Mapping of logical channels into physical channels

### 9.5.1 General mapping of logical channels

Table 33 defines the mapping in time of logical channels into physical channel types.

**Table 33: Mapping of logical channel into physical channels**

Logical channel	Direction	Burst type	SSN/Block	Physical channel	FN	TN
BSCH	DL	SB	<i>BKN1</i> <i>BKN1</i>	CP, TP UP	18 1...18	$4-(MN+1)\text{mod}4\#$ 1...4
BNCH	DL	NDB NDB SB	<i>BKN2</i> <i>BKN2</i> <i>BKN2</i>	CP,TP CP UP	18 1...18 1...18	$4-(MN+3)\text{mod}4\#$ 1...4 1...4
AACH	DL	NDB, SB	<i>BBK</i>	CP, TP, UP	1...18	1...4#
BLCH	DL	NDB,SB	<i>BKN2</i>	CP, UP TP	1...18 18	1...4 1...4
CLCH	UL	LB	<i>SSN1</i> <i>SSN1</i>	CP, TP CP, UP	18 1...18	$4-(MN+1)\text{mod}4\#$ 1...4
SCH/F	DL	NDB	<i>BKN1+BKN2</i>	CP TP	1...18 18	1...4 1...4
	UL	NUB	<i>BKN1+BKN2</i>	CP TP	1...18 18	1...4 1...4
SCH/HD	DL	NDB, SB	<i>BKN1, BKN2</i>	CP, UP TP	1...18 18	1...4 1...4
SCH/HU	UL	CB	<i>SSN1, SSN2</i>	CP TP	1...18 18	1...4 1...4
TCH	DL	NDB	<i>BKN1, BKN2</i>	TP	1...17	1...4
	UL	NUB	<i>BKN1, BKN2</i>	TP	1...17	1...4
STCH	DL	NDB	<i>BKN1, BKN2</i>	TP	1...17	1...4
	UL	NUB	<i>BKN1, BKN2</i>	TP	1...17	1...4

NOTE: # indicates a mandatory mapping.

The mapping shall be as summarized in the following tables.

**Table 34: TDMA frame mapping on TP channel**

Frame FN	DOWNLINK		UPLINK	
	Block <i>BKN1</i>	Block <i>BKN2</i>	Subslot <i>SSN1</i> or Block <i>BKN1</i>	Subslot <i>SSN2</i> or Block <i>BKN2</i>
1 to 17	TCH STCH + TCH STCH + STCH		TCH STCH + TCH STCH + STCH	
18	SCH/HD BSCH SCH/HD	SCH/HD SCH/HD BNCH	SCH/HU CLCH	SCH/HU SCH/HU

**Table 35: TDMA frame mapping on CP channel**

Frame FN	DOWNLINK		UPLINK	
	Block <i>BKN1</i>	Block <i>BKN2</i>	Subslot <i>SSN1</i> or Block <i>BKN1</i>	Subslot <i>SSN2</i> or Block <i>BKN2</i>
1 to 18	SCH/F SCH/HD SCH/HD		SCH/F SCH/HU CLCH	
18	BSCH	SCH/HD		SCH/HU SCH/HU

**Table 36: TDMA frame mapping on unallocated physical channel**

Frame <i>FN</i>	DOWNLINK		UPLINK	
	Block <i>BKN1</i>	Block <i>BKN2</i>	Subslot <i>SSN1</i>	Subslot <i>SSN2</i>
1 to 18	SCH/HD BSCH	SCH/HD BNCH	CLCH	

In all cases the AACH shall be mapped onto the broadcast block of each downlink slot. On the downlink the BLCH may replace the SCH/HD of the block *BKN2*.

## 9.5.2 Mapping of BCCH and CLCH

The BCCH and CLCH shall be mapped on the control frame of CP and TP channels.

**Table 37: Mapping of the BCCH onto the control frame**

Multiframe	Frame <i>FN18</i>	Timeslot			
		<i>TN1</i>	<i>TN2</i>	<i>TN3</i>	<i>TN4</i>
$(MN) \bmod 4 = 1$	downlink <i>BKN1</i>		BSCH		
	downlink <i>BKN2</i>				BNCH
	uplink <i>SSN1</i>		CLCH		
$(MN) \bmod 4 = 2$	downlink <i>BKN1</i>	BSCH			
	downlink <i>BKN2</i>			BNCH	
	uplink <i>SSN1</i>	CLCH			
$(MN) \bmod 4 = 3$	downlink <i>BKN1</i>				BSCH
	downlink <i>BKN2</i>		BNCH		
	uplink <i>SSN1</i>				CLCH
$(MN) \bmod 4 = 0$	downlink <i>BKN1</i>			BSCH	
	downlink <i>BKN2</i>	BNCH			
	uplink <i>SSN1</i>			CLCH	

The mapping of the BCCH and CLCH on the control frame shall be a function of the time slot and multiframe numbers and shall be obtained from the following algorithms or from table 37.

- Down-link:
  - BNCH mapped if:
    - $FN = 18$  and  $(MN + TN) \bmod 4 = 1$  (72)
  - BSCH mapped if:
    - $FN = 18$  and  $(MN + TN) \bmod 4 = 3$  (73)
- Up-link:
  - CLCH mapped if:
    - $FN = 18$  and  $(MN + TN) \bmod 4 = 3$  (74)

The BSCH shall always be transmitted on a synchronization burst.

In addition to this mapping the BS may map the CLCH onto the up-link subslot 1 and the BNCH on the downlink block 2 of a CP channel. The mapping shall be performed on a slot to slot basis. The mapping of the CLCH shall be indicated on the AACH.

A MS may linearize its transmitter at any CLCH occurrence, even from another physical channel, provided this does not violate other mapping rules. The number of MS transmitter linearizations on one carrier is limited to once per multiframe period.

The BLCH may be mapped onto block 2 of the downlink slots, when a SCH/HD or a BSCH is mapped onto block 1. The number of BLCH occurrences on one carrier shall not exceed one per 4 multiframe periods.

At initial power-on of an RF carrier, the BS may linearize its transmitter using the BLCH. In this case the BLCH is mapped on a burst similar to the downlink linearization burst, but with an unspecified duration preceding the start burst.

Slots of an unallocated physical channel may be filled up with the BCCH, the BSCH is mapped onto block 1 and BNCH onto block 2. Whenever a BCCH is mapped on the down-link, a CLCH may also be mapped into the up-link.

### 9.5.3 Mapping of SCH

On the up-link one SCH/F or two SCH/HU (one on each subslot) may be mapped, except if a CLCH is mapped on subslot 1 (formula 3) then only one SCH/HU may be mapped, onto subslot 2. On the down-link one SCH/F or two SCH/HD may be mapped on blocks 1 and 2 except on the control frame if a BNCH is mapped onto block 2, then only one SCH/HD shall be mapped onto block 1.

Whenever a normal downlink burst is transmitted on an UP channel and if no BCCH is transmitted then the SCH/HD shall be mapped onto blocks 1 and 2. The SCH/HD shall contain dummy messages (null SDU as described in clause 21).

The BS shall indicate on the AACH the type of logical channel(s) to be used on the next up-link subslot (SCH/HU or CLCH) or slot (SCH/F). This indication shall only be valid within one frame and for one physical channel.

In the case where several downlink TP channels are allocated to one single communication, the uplink and downlink SCH shall be mapped onto frame FN18 of the allocated physical channel showing the lowest timeslot number TN.

In the case where several uplink TP channels are allocated to one single communication, the uplink and downlink SCH shall be mapped onto frame FN18 of the allocated physical channel showing the highest timeslot number TN.

In the case where several downlink and uplink TP channels have been allocated simultaneously to one single communication, the uplink and downlink SCH shall be mapped onto frame FN18 of the allocated physical channel showing the lowest timeslot number TN.

### 9.5.4 Mapping of TCH and STCH

The TCH shall be mapped onto blocks 1 and 2 of the frames 1 to 17 of a TP channel.

The STCH may be mapped onto any frame allowed for traffic. The STCH steals a part or all of the TCH bits within a burst.

The presence of stolen traffic in one burst shall be indicated by the type of training sequence.

In case of stealing, the STCH shall always steal first the first half slot of the burst.

### 9.5.5 Mapping of AACH

The AACH is mapped onto the broadcast block of each downlink slot.

## 9.6 Monitoring pattern for transmitting MSs

A particular monitoring pattern shall be referenced by its Monitoring Pattern Number (MPN). The monitoring patterns shall be numbered from 1 to 3. The BS shall assign 0 to 3 patterns to each up-link TCH during the call or transaction set-up. The transmitting MS shall monitor at least all frames belonging to the assigned monitoring pattern(s). In some cases, the BS may allocate no monitoring pattern, but, as a result, the MS may not be so easily reachable.

For a given monitoring pattern, the frame sequence may be obtained with the following formula or by using table 38.

$$(MN + MPN - 1) \bmod 3 = (FN) \bmod 3 \quad (75)$$

Table 38: Monitoring patterns for transmitting MSs

Multiframe	Monitoring Patterns		
	MPN 1	MPN 2	MPN 3
$(MN) \bmod 3 = 1$	FN1, 4, 7, 10, 13, 16	FN2, 5, 8, 11, 14, 17	FN3, 6, 9, 12, 15, 18
$(MN) \bmod 3 = 2$	FN2, 5, 8, 11, 14, 17	FN3, 6, 9, 12, 15, 18	FN1, 4, 7, 10, 13, 16
$(MN) \bmod 3 = 0$	FN3, 6, 9, 12, 15, 18	FN1, 4, 7, 10, 13, 16	FN2, 5, 8, 11, 14, 17

## 9.7 BS timesharing transmission

### 9.7.1 Carrier sharing

In carrier sharing mode one carrier frequency shall be shared among up to four cells, each cell being allocated at least one physical channel. The mapping of logical channels into physical channels shall follow the general mapping rules, except that on the downlink discontinuous bursts shall be used. (see also clause 23.3.2.1).

### 9.7.2 MCCH sharing

In MCCH sharing mode, the MCCH shall be shared among several cells. The TDMA frames of the MCCH shall be divided into frames reserved to one BS (reserved frames) and frames shared by all cells (common frames). The BS shall transmit during the reserved frames and may transmit during the common frames. The transmission during the common frames should be managed by the network (see also clause 23.3.2.2).

The frames reserved for a BS shall be calculated from the TS\_RESERVED\_FRAMES parameter that indicates the number of reserved frames per two multiframes. This parameter may take one of the following values:

- 1, 2, 3, 4, 6, 9, 12, 18.

And shall be broadcast on the BSCH. Up to 36 cells may share the same MCCH. The FN of the reserved frames may be obtained from the following formula or from table 39.

- the frame  $FN$  in the multiframe  $MN$  is reserved to the BS if:

$$- FN + 18 [(MN + 1) \bmod 2] \text{ is a multiple of } 36/\text{TS\_RESERVED\_FRAMES} \quad (76)$$

For any value of TS\_RESERVED\_FRAMES, frame 18 of the even multiframes shall be reserved, in order to transmit the BCCH. The TDMA frame and multiframe numbering of all cells sharing one MCCH shall be offset in order to avoid collision of the transmitted bursts.

The allocation of the common frames shall be sent on the BNCH.

The mappings of logical channel into physical channel shall follow for the reserved and common frames the same rules as for continuous transmission, except that on the downlink the discontinuous bursts shall be used.

## 9.8 Modes of control

Two modes of control are defined:

- Normal Control Mode (NCM); and
- Minimum Control Mode (MCM).

### 9.8.1 NCM

The NCM is a mode of operation providing the TETRA services with full performance. In NCM a MCCH shall be assigned.

## 9.8.2 MCM

The MCM is a mode of operation providing the TETRA services with reduced performance. In MCM all physical channels may be TP channels.

**Table 39: Reserved frames in BS timing**

Multi-frame MN	Frame FN	RESERVED FRAMES							
		1	2	3	4	6	9	12	18
odd	1								
	2								
	3								
	4								
	5								
	6								
	7								
	8								
	9								
	10								
	11								
	12								
	13								
	14								
	15								
	16								
	17								
	18								
even	1								
	2								
	3								
	4								
	5								
	6								
	7								
	8								
	9								
	10								
	11								
	12								
	13								
	14								
	15								
	16								
	17								
	18								

**Table 40: Void**

# 10 Radio subsystem link control

## 10.1 Introduction

This clause specifies the radio subsystem link control implementation in mobile and BSs for V+D. The following aspects of radio subsystem link control are addressed:

- RF power control;
- the basis for signal strength measurement.

## 10.2 RF power control

Adaptive RF power control shall be used by the MS. By minimizing the transmit power levels, interference to co-channel and adjacent channel users is reduced and MS power consumption could be reduced. Adaptive RF power control shall not be used by the BS.

## 10.3 Radio link measurements

The radio link measurements include signal strength, signal quality and round-trip MS-BS path delay.

### 10.3.1 Received signal strength

The received signal strength shall be measured over the range from -115 dBm to -50 dBm with an absolute accuracy of  $\pm 4$  dB. The relative accuracy between two measurements on the same carrier or on different carriers shall be  $\pm 3$  dB.

#### 10.3.1.1 Sample duration for signal strength measurement

To enable correct measurement of the received signal strength, the minimum Sample Duration (SD) shall be one of the following defined values:

- SD1 = 1 ms sample duration;
- SD2 = 4 ms sample duration.

### 10.3.2 Signal quality

The quality of the radio downlink shall be estimated from the success rate of decoding the AACH (see clause 23).

### 10.3.3 Round-trip MS-BS path delay

The round-trip MS-BS path delay may be used by the BS as a criterion to relinquish a radio uplink. The path delay of the MS is a representation of the distance of the MS to the serving BS. This distance may be used to prevent MS grossly exceeding the planned cell boundaries. This information may be sent by the BS to the MS when appropriate. The allowable distance may be restricted on a cell to cell basis by the network operator, as required.

---

# 11 Call Control (CC) service description

## 11.1 Introduction

This clause describes the services offered by the CC sub-entity in the Circuit Mode Control Entity (CMCE). The CC Service Access Point (SAP) is used in conformance testing as a normative boundary in TETRA MSs and TETRA LSs.

## 11.2 Services offered

The CC services shall be provided with a CC sub-entity at the service access point TNCC-SAP. In order to cater for concurrent services there may exist multiple instances of the TNCC-SAP running at the same time.

At the TNCC-SAP one instance of the call control shall consist a set of the following calling user application and called user application services:

- basic call set-up (with attributes);
- call maintenance;
- Dual Tone Multiple Frequency (DTMF) encoding and sending;



- PTT requests/grants/information;
- call clearance;
- change of tele/bearer service within a call.

## 11.3 CC service

### 11.3.1 CC primitives exchanged through the TNCC-SAP

The flow of CC primitives shall be as illustrated in figure 13.

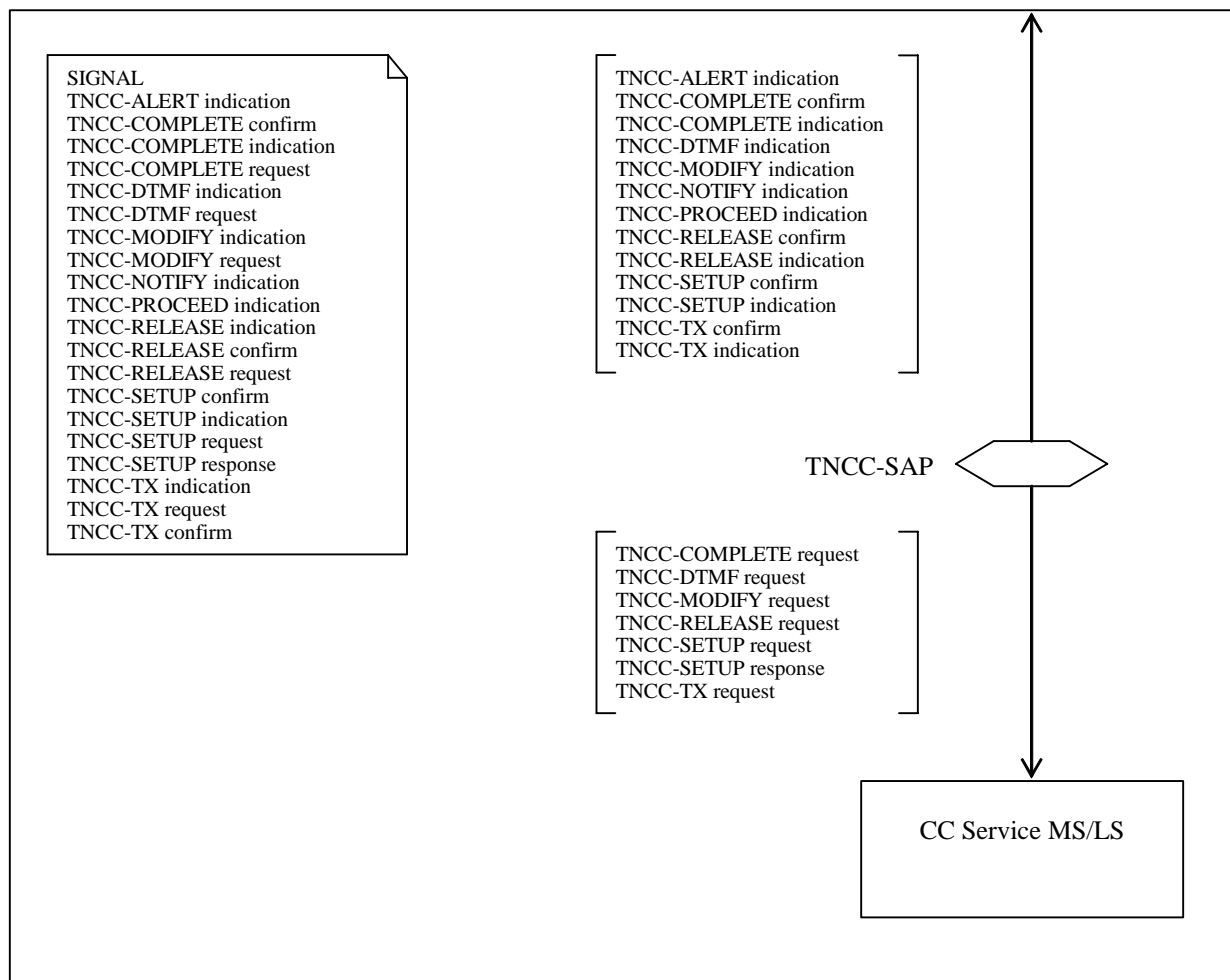


Figure 13: CC services provided at TNCC-SAP MS/LS-side

### 11.3.2 Service primitives at the TNCC-SAP

Each TNCC-SAP shall be characterized by a SAP and the set of service primitives available for each SAP shall be as specified in this clause.

**TNCC-ALERT indication:** the primitive shall be used in the call set-up phase towards the calling user application when on/off hook signalling is employed.

**TNCC-COMplete request/indication/confirm:** the primitive shall be used as a termination of the call set-up phase at the called user application.

**TNCC-DTMF request/indication:** the primitives may be used during a circuit mode call to exchange DTMF information between user applications.

**TNCC-MODIFY request/indication:** the primitives may be used during call active phase as an indication that an existing tele or bearer service has been modified.

**TNCC-NOTIFY indication:** the primitives may be used during call set-up and call active phases to notify the user application about the status of the call.

**TNCC-PROCEED indication:** the primitive may be used during call set-up phase to indicate progress of the call set-up.

**TNCC-RELEASE request/indication/confirm:** the primitives shall be used to initiate the call release phase. Further it shall be used to indicate the termination of the call release phase. The primitives may also be used during the call set-up phase to request or indicate rejection of a call.

**TNCC-SETUP request/indication/response/confirm:** the primitives shall be used to initiate the call set-up phase and shall also be used to indicate the termination of the call set-up phase.

**TNCC-TX request/indication/confirm:** the primitives shall be used during call active phase to request and indicate change in the transmission permission.

### 11.3.3 Primitive description

The information contained in the primitive description tables which follow corresponds to the following key:

- M: Mandatory;
- C: Conditional;
- O: Optional;
- -: Not used.

#### 11.3.3.1 TNCC-ALERT primitive

TNCC-ALERT indication shall be used to indicate to the calling user application, that the call has been received, and alerting at the called user application has been initiated. The called user application is using on/off hook signalling and the primitive indicates that the called user application is alerting.

The parameters are defined in table 41.

**Table 41: Parameters for the primitive TNCC-ALERT**

Parameter	Indication
Basic service information (offered):	
Circuit mode service	O
Communication type	O
Data call capacity	C (see note)
Data service	C (see note)
Encryption flag	O
Speech service	C (see note)
Call queued	O
Call time-out, set-up phase	M
Simplex/duplex	M
NOTE: Depending on the value of circuit mode service.	

### 11.3.3.2 TNCC-COMplete primitive

TNCC-COMplete request shall be used by the called user application to complete individual call set-up.

TNCC-COMplete indication shall be used as an indication to the called user application that the call set-up has been completed. The called user application shall also be informed whether the SwMI has granted transmission permission to the calling user application or whether the right to transmit has been handed over to the another user application.

TNCC-COMplete confirm shall be used to confirm to the called user application that the call set-up has been completed.

The parameters are defined in table 42.

**Table 42: Parameters for the primitive TNCC-COMplete**

Parameter	Request	Indication	Confirm
Access priority	O	-	-
Basic service information (offered):			
Circuit mode service	O	-	-
Communication type	O	-	-
Data call capacity	C (see note)	-	-
Data service	C (see note)	-	-
Encryption flag	O	-	-
Speech service	C (see note)		
Call time-out	-	M	M
Hook method	M	-	-
Simplex/duplex	M	-	-
Transmission grant	-	M	M
Transmission request permission	-	M	M
Transmission status	-	M	M
Traffic stealing	O	-	-
NOTE: Depending on the value of circuit mode service.			

### 11.3.3.3 TNCC-DTMF primitive

TNCC-DTMF request shall be used as a request from the user application to send a number of DTMF digits to another user application.

TNCC-DTMF indication shall be used as an indication to the user application that a number of DTMF digits has arrived from another user application.

The parameters are defined in table 43.

**Table 43: Parameters for the primitive TNCC-DTMF**

Parameter	Request	Indication
Access priority	O	-
DTMF tone delimiter	M	O (see note 4)
DTMF result	-	C (see note 3)
Number of DTMF digits	C (see note 1)	C (see note 2)
DTMF digits	C (see note 1)	C (see note 2)
Traffic stealing	O	-
NOTE 1: Present when the value of DTMF tone delimiter is "DTMF tone start".		
NOTE 2: Present when DTMF tone delimiter is present and set to "DTMF tone start".		
NOTE 3: Present when DTMF tone delimiter is not present.		
NOTE 4: The time difference between "DTMF tone start" and "DTMF tone end" may not correspond to the tone duration at the originator.		

### 11.3.3.4 TNCC-MODIFY primitive

TNCC-MODIFY request shall be used as a request from the user application to the SwMI to change the call attributes and/or the simplex/duplex selection.

NOTE: If a change in call attribute is requested, it cannot change from point-to-multipoint to point-to-point.

TNCC-MODIFY indication shall be used as an indication to a user application that the call attribute has changed from one tele/bearer service to another tele/bearer service. The primitive shall also be used for indicating a change in the call timer or a change in the simplex/duplex operation.

The parameters are defined in table 44.

**Table 44: Parameters for the primitive TNCC-MODIFY**

Parameter	Request	Indication
Access priority	O	-
Basic service information (new):		
Circuit mode service	O	O
Communication type	O	O
Data call capacity	C (see note)	C (see note)
Data service	C (see note)	C (see note)
Encryption flag	O	O
Speech service	C (see note)	C (see note)
Call time-out	-	O
Simplex/duplex	O	O
Traffic stealing	O	-
NOTE: Depending on the value of circuit mode service.		

### 11.3.3.5 TNCC-NOTIFY primitive

TNCC-NOTIFY indication shall provide information from the SwMI to the user application about a circuit mode call.

The parameters are defined in table 45.

**Table 45: Parameters for the primitive TNCC-NOTIFY**

Parameter	Indication
Call status	O
Call time-out in set-up phase	O
Call time-out	O
Call ownership	O
Poll response percentage	O (see note)
Poll response number	O (see note)
Poll response addresses	O (see note)
Poll request	O
NOTE: Only one of these values is applicable in a service primitive.	

### 11.3.3.6 TNCC-PROCEED primitive

TNCC-PROCEED indication shall be used as an indication to the user application that call establishment has been initiated in the SwMI. The indication may also contain information about changes in call attributes, changes in the hook method or the simplex/duplex operation.

The parameters are defined in table 46.

**Table 46: Parameters for the primitive TNCC-PROCEED**

Parameter	Indication
Basic service information (offered):	
Circuit mode service	O
Communication type	O
Data call capacity	C (see note)
Data service	C (see note)
Encryption flag	O
Speech service	C (see note)
Call status	O
Hook method	O
Simplex/duplex	O
NOTE: Depending on the value of circuit mode service.	

### 11.3.3.7 TNCC-RELEASE primitive

TNCC-RELEASE request shall be used by the user application to either leave a continuing call or request disconnection of the call. If he wants to disconnect the call the SwMI is requested to release the connection. The SwMI is also requested to release the call identifier and all connections associated with it.

TNCC-RELEASE indication shall be used as an indication to the user application, that the SwMI has released the call identifier and the corresponding connection. This primitive may also indicate a loss of resources at a lower layer.

TNCC-RELEASE confirm shall be used to indicate to the initiator of the call release, that the SwMI has released the call identifier and the connection.

The parameters are defined in table 47.

**Table 47: Parameters for the primitive TNCC-RELEASE**

Parameter	Request	Indication	Confirm
Access priority	O	-	-
Disconnect cause	M	M	M
Disconnect status	-	-	M
Disconnect type	M	-	-
Traffic stealing	O	-	-

### 11.3.3.8 TNCC-SETUP primitive

TNCC-SETUP request shall be used to initiate the call establishment of a circuit switched call by a calling user application.

TNCC-SETUP indication shall be used as an indication to a called user application that a call establishment has been initiated and a circuit switched call is in progress or has been established.

TNCC-SETUP response shall be used by the called user application to indicate that the call has been accepted and call set-up can now proceed towards the call active phase. The user application may change the attributes of the call and the simplex/duplex operation may be changed.

TNCC-SETUP confirm shall be used as a confirmation to the calling user application that the call set-up phase has now been terminated by the SwMI and an end-to-end connection has been set-up. The call shall now be considered as being in its active phase.

The parameters are defined in table 48.

**Table 48: Parameters for the primitive TNCC-SETUP**

Parameter	Request	Indication	Response	Confirm
Access priority	O	-	O	-
Area selection	O (see note 6)	-	-	-
Basic service information:				
Circuit mode service	M	M	O	M
Communication type	M	M	O	M
Data call capacity	C (see note 1)	C (see note 1)	C (see note 1)	C (see note 1)
Data service	C (see note 1)	C (see note 1)	C (see note 1)	C (see note 1)
Encryption flag	M	M	O	M
Speech service	C (see note 1)	C (see note 1)	C (see note 1)	C (see note 1)
Call priority	M	M	-	O
Call ownership	-	-	-	M
Call amalgamation	-	-	-	M
Call time-out	-	M	-	M
Called party type identifier	M	-	-	-
Called party SNA	C (see note 2)	-	-	-
Called party SSI	C (see notes 2, 3)	M	-	-
Called party extension	C (see note 2)	O (see note 4)	-	-
External subscriber number (called)	O	-	-	-
Calling party:				
Calling party SSI	-	O	-	-
Calling party extension	-	O (see note 4)	-	-
External subscriber number (calling)	-	O	-	-
CLIR control	O (see note 7)	O (see note 7)	O (see note 7)	-
Hook method selection	M	M	M	M
Request to transmit/send data	M	-	-	-
Simplex/duplex selection	M	M	M	M
Traffic stealing	O	-	O	-
Transmission grant	-	M (see note 5)	-	M (see note 5)
Transmission request permission	-	M	-	M
NOTE 1: Depending on the value of circuit mode service type.				
NOTE 2: Depending on the value of called party type identifier.				
NOTE 3: The application should ensure that individual calls (basic service) use called party ISSI, and group calls use GSSI.				
NOTE 4: If not present, the user application shall assume that the address extension is the MNI of the current network.				
NOTE 5: Transmission grant is applicable also in duplex calls.				
NOTE 6: Usage of this parameter is defined in EN 300 392-12-8 [34].				
NOTE 7: Usage of this parameter is defined in EN 300 392-12-1 [16].				

### 11.3.3.9 TNCC-TX primitive

TNCC-TX request shall be used as a request from the user application that it wants to transmit or that it has ceased its transmission. In the request for transmission the requested priority and the encryption mode shall be indicated. The user application should use a TNCC-TX request for a request to transmit only when a previous TNCC-TX indication has indicated that a request for transmission is allowed.

TNCC-TX indication shall be used as an indication to the user application concerning the transmit status of the call. The primitive shall also be used to inform the user application about whether another user has been granted transmission or ceased its transmission. The encryption state of the actual transmission is indicated in the encryption control parameter.

TNCC-TX confirm shall be used as a confirmation to the user application that the request to transmit has been granted. The encryption state of the actual transmission is indicated in the encryption control parameter.

The parameters are defined in table 49.

**Table 49: Parameters for the primitive TNCC-TX**

Parameter	Request	Indication	Confirm
Access priority	O	-	-
Encryption flag	M	M	M
Transmitting party SSI	-	O	-
Transmitting party extension	-	O (see note)	-
External subscriber number	-	O	-
Traffic stealing	O	-	-
Transmission condition	M	-	-
Transmit request permission	-	M	M
Transmission status	-	M	M
Tx demand priority	M	-	-
NOTE: If not present, the user application shall assume that the address extension is the MNI of the current network.			

**Table 50: Void**

### 11.3.4 Parameter description

Parameters shall be part of the primitives described in clause 11.3.3 and if applied the parameters shall contain the values specified in this clause. These values are selected to correspond to element values used in the air interface protocol.

- Access priority =
  - low priority;
  - high priority;
  - emergency priority.

The default value of the access priority parameter shall be "low priority", which will be applied when no access priority parameter is explicitly defined.

- Area selection =
  - area not defined;
  - area 1;
  - etc...;
  - area 14;
  - all areas in this system.

The default value of the area selection parameter shall be "area not defined", which will be applied when area selection is not used.

- Basic service information (a set of parameters) =
  - circuit mode service;
  - communication type;
  - data service;
  - data call capacity (data service only);
  - encryption flag;
  - speech service.
- Call amalgamation =

- call not amalgamated;
- call amalgamated.
- Call ownership =
  - a call owner;
  - not a call owner.
- Call priority =
  - priority not defined;
  - lowest priority;
  - etc...;
  - highest non-pre-emptive priority;
  - lowest pre-emptive priority;
  - etc...;
  - second highest pre-emptive priority;
  - emergency pre-emptive priority.
- Call queued =
  - call is not queued;
  - call is queued.
- Call status =
  - call status unknown;
  - call is progressing;
  - call is queued;
  - requested subscriber is paged;
  - call continue;
  - hang timer has expired.
- Call time-out =
  - call time-out infinite;
  - call time-out value-1;
  - call time-out value-2;
  - etc, ...;
  - call time-out value-15;
  - Refer to clause 14.2.15 for the time-out values.
- Call time-out in set-up phase =
  - call time-out pre-defined;
  - call time-out value-1;
  - call time-out value-2;



- etc...;
- call time-out value-7;
- Refer to clause 14.2.16 for the time-out values.
- Called party extension =
  - country code and network code part of TSI.
- Called party SNA =
  - Short Number Address (SNA).
- Called party SSI =
  - Short Subscriber Identity (SSI).
- Called party type identifier =
  - SNA;
  - SSI;
  - TETRA subscriber identity (TSI).
- Calling party extension =
  - Mobile Country Code (MCC) + Mobile Network Code (MNC).
- Calling party SSI =
  - Individual Short Subscriber Identity (ISSI).
- Circuit mode service =
  - data service;
  - speech service.
- CLIR control =
  - not implemented or use default mode;
  - presentation not restricted;
  - presentation restricted.
- Communication type =
  - point-to-point;
  - point-to-multipoint;
  - point-to-multipoint acknowledged;
  - broadcast.
- Data service (service per one time slot) =
  - unprotected: 7,2 kbit/s, no interleaving;
  - low protection: 4,8 kbit/s, short interleaving depth = 1;
  - low protection: 4,8 kbit/s, medium interleaving depth = 4;
  - low protection: 4,8 kbit/s, long interleaving depth = 8;

- high protection: 2,4 kbit/s, short interleaving depth = 1;
- high protection: 2,4 kbit/s, medium interleaving depth = 4;
- high protection: 2,4 kbit/s, long interleaving depth = 8.

NOTE 1: The increase in interleaving depth gives a better error protection, but also generates a longer transmission delay.

- Data call capacity =
  - one time slot;
  - two time slots;
  - three time slots;
  - four time slots.
- Disconnect cause =
  - cause not defined or unknown;
  - user requested disconnect;
  - called party busy;
  - called party not reachable;
  - called party does not support encryption;
  - congestion in infrastructure;
  - not allowed traffic case;
  - incompatible traffic case;
  - requested service not available;
  - pre-emptive use of resource;
  - invalid call identifier;
  - call rejected by the called party;
  - no idle CC entity;
  - expiry of timer;
  - SwMI requested disconnection;
  - acknowledged service not completed;
  - loss of resources;
  - usage marker failure;
  - called party requires encryption;
  - concurrent set-up not supported;
  - called party is under the same DM-GATE of the calling party.
- Disconnect status =
  - disconnection successful;
  - disconnection unsuccessful, the user is released from the call;

- disconnection unsuccessful, not the call owner, the user is released from the call;
- the user is released from the call.
- Disconnect type =
  - disconnect call;
  - leave call without disconnection;
  - leave call temporarily.
- DTMF digits =
  - Each digit shall be one of the following:
  - digit 0;
  - etc...;
  - digit 9;
  - digit \*;
  - digit #;
  - digit A;
  - digit B;
  - digit C;
  - digit D.
- DTMF result =
  - DTMF not supported;
  - DTMF not subscribed.
- DTMF tone delimiter =
  - DTMF tone start;
  - DTMF tone end.

NOTE 2: The length of the received DTMF tone may be modified by the lower layer protocol depending on the signalling capacity availability.

- Encryption flag =
  - clear end-to-end transmission;
  - encrypted end-to-end transmission.
- External subscriber number digits =
  - Up to 24 digits. Each digit shall be one of the following:
  - digit 0;
  - etc...;
  - digit 9;
  - digit \*;
  - digit #;

- digit +.
- Hook method selection =
  - no hook signalling (direct through-connect);
  - hook on/hook off signalling (individual call); and call acceptance signalling (group call).
- Number of DTMF digits =
  - 1 to 254.
- Poll request =
  - no poll answer requested;
  - poll answer requested.
- Poll response addresses =
  - TSI addresses 1-N.
- Poll result identifier =
  - poll result not known;
  - the percentage of responding group members;
  - the number of responding group members;
  - the addresses of the responding group members.
- Poll response number =
  - no poll response;
  - 1 poll response;
  - etc...;
  - 63 or more poll responses.
- Poll response percentage =
  - 0 %;
  - 1 %;
  - etc...;
  - 100 %.
- Request to transmit/send data =
  - request to transmit/send data;
  - request that other MS/LS may transmit/send data.
- Simplex/duplex selection =
  - simplex operation;
  - duplex operation.
- Speech service =
  - TETRA encoded one timeslot speech;

- proprietary encoded one timeslot speech.
- Traffic stealing =
  - do not steal traffic;
  - steal traffic.

The default value of the traffic stealing parameter shall be "do not steal traffic", which will be applied when no traffic stealing parameter is explicitly defined, not used or otherwise defined in the protocol.

- Transmission condition =
  - request to transmit;
  - transmission ceased.
- Transmission grant =
  - transmission granted;
  - transmission not granted;
  - transmission request queued;
  - transmission granted to another user.
- Transmission request permission =
  - allowed to request for transmission;
  - not allowed to request for transmission.
- Transmission status =
  - transmission ceased;
  - transmission granted;
  - transmission not granted;
  - transmission request queued;
  - transmission granted to another user;
  - transmission interrupt;
  - transmission wait;
  - transmission request failed.
- Transmitting party extension =
  - Mobile Country Code (MCC) + Mobile Network Code (MNC).
- Transmitting party SSI =
  - Individual Short Subscriber Identity (ISSI); or
  - Group Short Subscriber Identity (GSSI).
- Tx demand priority =
  - low priority;
  - high priority;
  - pre-emptive priority;

- emergency pre-emptive priority.

The default value of the TX demand priority parameter shall be "low priority", which will be applied when no TX demand priority parameter is explicitly defined.

## 11.4 States for CC SAP

The state transitions visible at the TNCC-SAP shall be as shown in figure 14.

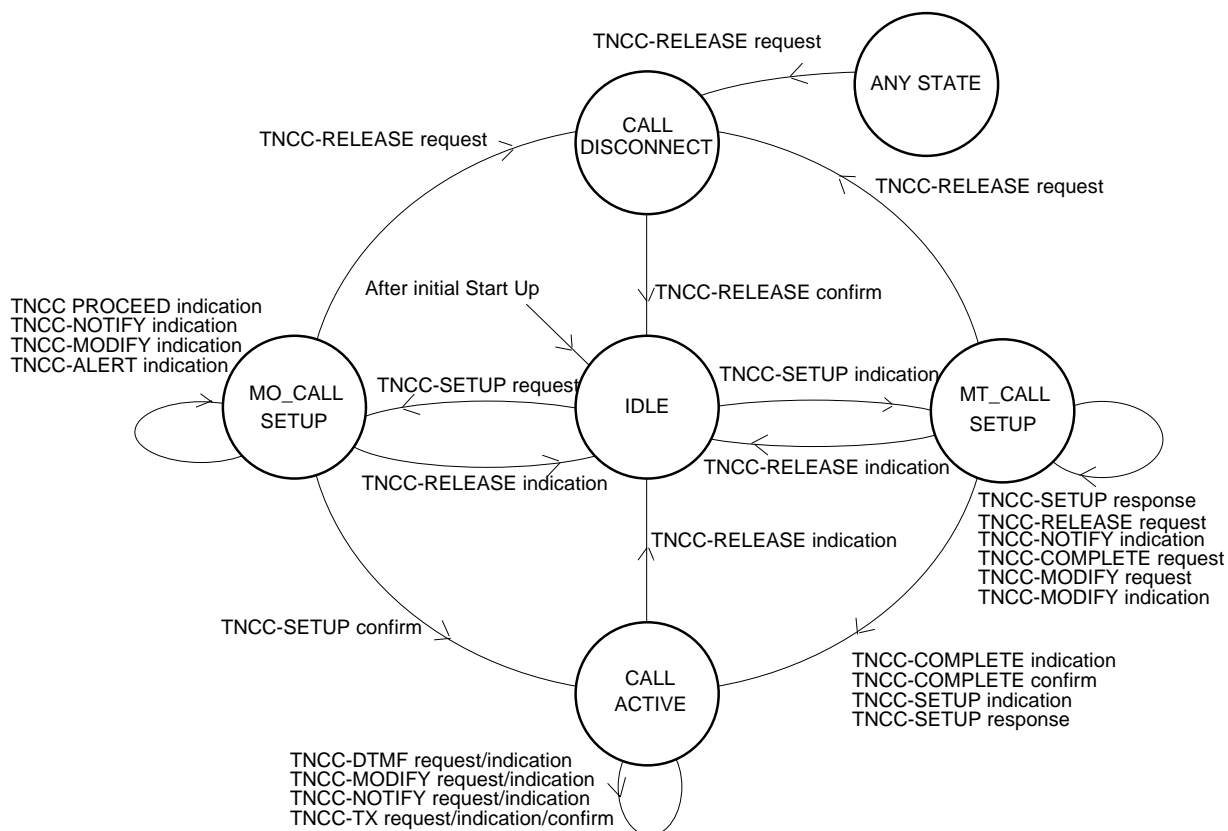


Figure 14: State transition diagram for one instance at the CC SAP

## 12 Supplementary Service (SS) service description

### 12.1 Introduction

This clause describes general services offered by the CMCE at the SS SAP of the TETRA V+D layer 3 service boundary. This SAP with the CC SAP is used in supplementary service conformance testing as a normative boundary in TETRA MSs and in TETRA LSs.

## 12.2 Services offered

The SS services are provided at the TNSS-SAP and TNCC-SAP. Refer to clause 11.3 on those supplementary services which utilize also TNCC-SAP. For call related actions the TNSS-SAP and TNCC-SAP are linked together by the call instance and, therefore, there is no "call identifier" parameter in the primitives.

The SS may consist of the following services:

- invocation of an SS;
- activation/deactivation of an SS;
- definition of an SS;
- cancellation of an SS;
- interrogation of an SS;
- registration of a user to a supplementary service;
- reception of supplementary service messages.

## 12.3 SS service

### 12.3.1 Primitives exchanged through TNSS-SAP

The SS primitives are defined in EN 300 392-9 [12] and in each supplementary service stage 3 description EN/ETS 300 392-12 [13], when available.

**Figure 15: Void**

The supplementary service primitives shall contain in addition to supplementary services specific parameters also the access priority parameter as defined in table 51.

**Table 51: Parameters for the supplementary service primitives**

Parameter	Request	Indication	Response	Confirm
Access priority	O	-	O	-
Supplementary service dependent parameters				

### 12.3.2 Parameter description

Parameters shall be part of the primitives described in clause 12.3.1 and if applied the parameters shall contain the values specified in this clause. These values are selected to correspond to element values used in the air interface protocol.

- Access priority =
  - low priority;
  - high priority;
  - emergency priority.

The default value of the access priority parameter shall be "low priority", which will be applied when no access priority parameter is explicitly defined.

Table 52: Parameters for the primitive TNS-SERVICE (Void)

---

## 13 Short Data Service (SDS) service description

### 13.1 Introduction

This clause describes the services offered by the short data service sub-entity in the CMCE at the SDS SAP of the TETRA V+D layer 3 service boundary. The SDS SAP is used in conformance testing as a normative boundary in TETRA MSs and in TETRA LSs.

### 13.2 Services offered

The SDS shall be provided by a single SDS functional entity at the TNSDS-SAP.

The short data functional entity shall consist of the following mobile originated and mobile terminated services:

- a) user defined short message reception and transmission;
  - individual message;
  - group message.
- b) pre-defined short message reception and transmission;
  - individual message;
  - group message.

### 13.3 SDS

#### 13.3.1 SDS primitives exchanged through the TNSDS-SAP

**TNSDS-CANCEL request:** primitive may be used by the user application to cancel sending of a message before it is sent at least once over the air interface.

**TNSDS-STATUS request/indication:** primitives shall be used to send or receive a pre-coded message defined by either the present document or by the network operator.

**TNSDS-REPORT indication:** primitive shall be used to indicate whether a TNSDS-UNITDATA request or a TNSDS-STATUS request has been either transmitted successfully or the transmission failure reason.

**TNSDS-UNITDATA request/indication:** primitives shall be used to send or receive a user defined message.

The flow of short data service primitives shall be as illustrated in figure 16.



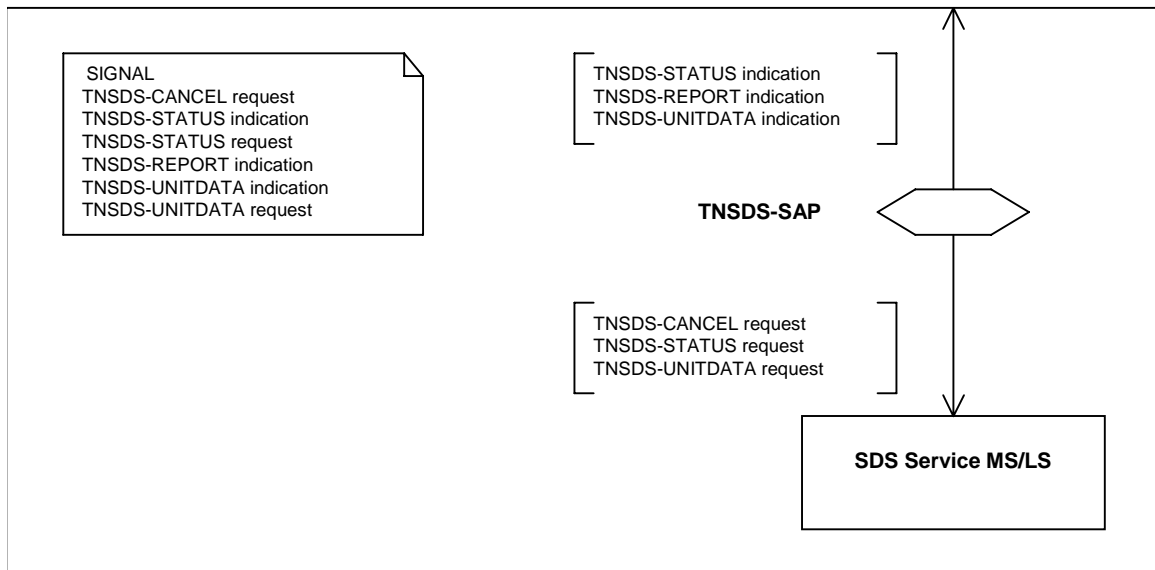


Figure 16: SDS provided at TNSDS-SAP (MS/LS-side)

### 13.3.2 Service primitives at the TNSDS-SAP

The information contained in the primitive description tables which follow corresponds to the following key:

- M: Mandatory;
- C: Conditional;
- O: Optional;
- -: Not used.

The SDS-TL protocol modifies the TNSDS primitives so that a certain range of Status number values of the TNSDS-STATUS primitives are used by the SDS-TL protocol and the User defined data-4 parameter is only available via the SDS-TL-SAP, refer to clause 29.1.1.

#### 13.3.2.1 TNSDS-STATUS primitive

TNSDS-STATUS request shall be used by the user application to send a pre-defined message to another user or users given in the address parameter.

NOTE: The status message is selected from a set of pre-coded messages and only the status number is given as a parameter.

TNSDS-STATUS indication shall indicate to the user application that a pre-coded status message from another user application has been received.

The parameters are defined in table 53.

**Table 53: Parameters for the TNSDS-STATUS primitive**

Parameter	Request	Indication
Access priority	O	-
Traffic stealing	O	-
Area selection	O (see note 3)	-
Called party type identifier	M	-
Called party SNA	C (see note 1)	-
Called party SSI	C (see note 1)	M
Called party extension	C (see note 1)	O (see note 2)
Called party address type	-	O
External subscriber number (called)	O	
Calling party SSI	-	M
Calling party extension	-	O (see note 2)
External subscriber number (calling)		O
Status number	M	M
Handle	M	-
NOTE 1: Depending on the value of called party type identifier.		
NOTE 2: If not present, the user application shall assume that the address extension is the MNI of the current network.		
NOTE 3: Usage of this parameter is defined in EN 300 392-12-8 [34].		

### 13.3.2.2 TNSDS-REPORT primitive

TNSDS-REPORT indication shall be used as an indication to the user application that the PDU belonging to a request, i.e. the TNSDS-UNITDATA request or the TNSDS-STATUS request, has been either transmitted successfully or lost.

The parameters are defined in table 54.

**Table 54: Parameters for the TNSDS-REPORT primitive**

Parameter	Indication
Transfer result	M
Handle	M

### 13.3.2.3 TNSDS-UNITDATA primitive

TNSDS-UNITDATA request shall be used by the user application to send a user defined message to another user application or applications given in the address parameter.

TNSDS-UNITDATA indication shall be used as an indication to the user that a user application defined message from another user application has been received. The message may either be a user defined individual message or a user defined group message.

The parameters are defined in table 55.

Table 55: Parameters for the TNSDS-UNITDATA primitive

Parameter	Request	Indication
Access priority	O	-
Traffic stealing	O	-
Area selection	O (see note 5)	-
Called party type identifier	M	-
Called party SNA	C (see note 1)	-
Called party SSI	C (see note 1)	M
Called party extension	C (see note 1)	O (see note 2)
Called party address type	-	O
External subscriber number (called)	O	-
Calling party:		
Calling party SSI	-	M
Calling party extension	-	O (see note 2)
External subscriber number (calling)	-	O
Short data type identifier	M	M
User defined data-1	C (see note 3)	C (see note 3)
User defined data-2	C (see note 3)	C (see note 3)
User defined data-3	C (see note 3)	C (see note 3)
User defined data-4	C (see notes 3, 4)	C (see notes 3, 4)
NOTE 1: Depending on the value of called party type identifier.		
NOTE 2: If not present, the user application shall assume that the address extension is the MNI of the current network.		
NOTE 3: Depending on the value of short data type identifier.		
NOTE 4: This parameter is modified by the SDS-TL protocol and it contains always a protocol identifier, and is available via the SDS-TL-SAP, refer to clause 29.1.1.		
NOTE 5: Usage of this parameter is defined in EN 300 392-12-8 [34].		

### 13.3.2.4 TNSDS-CANCEL primitive

TNSDS-CANCEL request may be used by the user application to cancel sending of a message before it is sent at least once over the air interface.

### 13.3.3 Parameter description

Parameters shall be part of the primitives at the TNSDS SAP. When applied the parameters shall contain the values specified in this clause.

- Access priority =
  - low priority;
  - high priority;
  - emergency priority.

The default value of the access priority parameter shall be low priority, which will be applied when no access priority parameter is used.

- Area Selection =
  - area not defined;
  - area 1;
  - etc...;
  - area 14;
  - all areas in this system.

The default value of the area selection parameter shall be "area not defined", which will be applied when area selection is not used.

- Called party address type =
  - broadcast;
  - individual;
  - group.
- Called party extension =
  - MCC + MNC.
- Called party short number address =
  - SNA.
- Called party SSI =
  - ISSI;
  - GSSI.
- Called party type identifier =
  - SNA;
  - SSI;
  - TSI.
- Calling party extension =
  - MCC + MNC.
- Calling party SSI =
  - ISSI.
- External Subscriber Number =
  - Up to 24 digits. Each digit shall be one of the following:
    - digit 0;
    - etc...;
    - digit 9;
    - digit \*;
    - digit #;
    - digit +.
- Handle =
  - a local SDU identifier.
- Status number =
  - 0 emergency call;
  - 1 to 31 743 reserved;
  - 32 768 to 65 535 available for TETRA network specific definition.

NOTE 1: Further status number definitions may be added in the maintenance of the present document as an annex.

NOTE 2: Pre-defined status values from 31 744 to 32 767 are used by SDS-TL protocol and will not be available as pre-defined status values.

- Short data type identifier =
  - user defined data-1;
  - user defined data-2;
  - user defined data-3;
  - user defined data-4.
- Traffic stealing =
  - do not steal traffic;
  - steal traffic.

The default value of the traffic stealing parameter shall be do not steal traffic, which will be applied when no traffic stealing parameter is used.

- Transfer result =
  - success;
  - failure.
- User defined data 1 =
  - 16 bit user defined data.
- User defined data 2 =
  - 32 bit user defined data.
- User defined data 3 =
  - 64 bit user defined data.
- User defined data-4 =
  - protocol identifier; and
  - user defined data bits, maximum length 2 039 bits.

### 13.3.4 State description

#### 13.3.4.1 NULL state

No short data message shall be in progress.

#### 13.3.4.2 SHORT DATA INITIATED state

Short data message sending in progress state. Waiting for the completion of a message transfer.

### 13.3.5 Service state diagram for the TNSDS-SAP

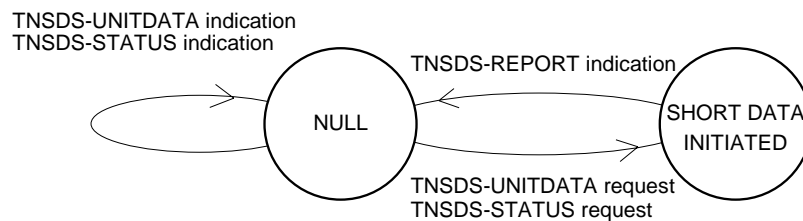


Figure 17: Service state diagram for the mobile terminated short data message

---

## 14 CMCE protocol

### 14.1 Introduction

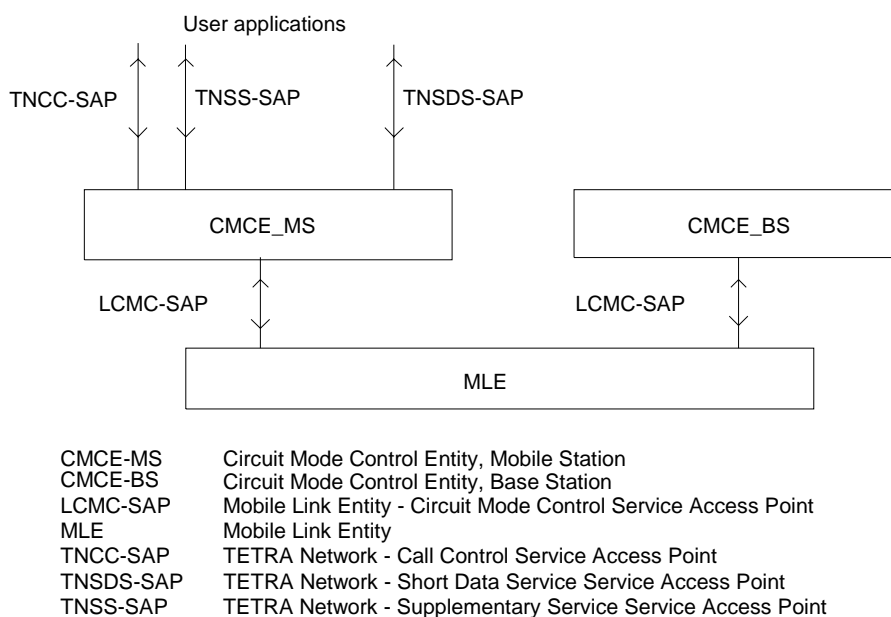
This clause defines the layer 3.2 CMCE air interface protocol for the MS and the LS. There shall be a peer-to-peer relationship between the layers on the terminal side and the SwMI side. The protocol for the SwMI side is, however, outside the scope of the present document. The CMCE protocol is the network layer protocol that shall be used to provide services to an end user application in the area of CC services, of SDS and of supplementary services.

This clause specifies:

- the functional requirements for implementations claiming conformance to the present document;
- procedures for specific transmission of:
  - control information for circuit mode services;
  - call unrelated short data messages;
  - control information for call related/call unrelated supplementary service messages.
- the encoding of the Protocol Data Units (PDUs) used for the transmission of data and control information;
- procedures for the correct interpretation of protocol control information.

### 14.2 Overview of CMCE

Figure 18 shows the position of the CMCE protocols in both the MS/LS and in the BS protocol stack. The present document does not define a BS protocol architecture or user application SAPs for the CMCE within the SwMI.



**Figure 18: System view**

### 14.2.1 Communication routes of the CMCE model

The CMCE model defines routes used for information exchange between the sub-entities as shown in figure 19.

The external routes are routes between a sub-entity of the CMCE and an entity in another layer. Each external route shall be mapped onto a SAP.

There are 4 external routes.

The ra route shall correspond to the TNCC-SAP. The primitives exchanged on that route are described in clause 11.

The rb route shall correspond to the TNSS-SAP. The primitives exchanged on that route are described in clause 12.

The rc route shall correspond to the TNSDS-SAP. The primitives exchanged on that route are described in clause 13.

The ri route shall correspond to the LCMC-SAP. The primitives exchanged on that route are described in clause 17.

The internal routes are routes between sub-entities of the CMCE.

There are 5 internal routes:

- the rd route shall be a route between the CC sub-entity and the PC sub-entity;
- the re route shall be a route between the SS sub-entity and the PC sub-entity;
- the rg route shall be a route between the SS sub-entity and the CC sub-entity;
- the rf route shall be a route between the SDS sub-entity and the PC sub-entity;
- the rh route shall be a route between the SS sub-entity and the SDS sub-entity.

## 14.2.2 Protocol structure and protocol stack

The CMCE is the layer 3 sub-layer for circuit mode CC, SS and SDS as described in clauses 11, 12 and 13 respectively. CMCE shall provide services to the user applications through service primitives defined for the following three SAPs:

- TNCC-SAP for CC services;
- TNSS-SAP for SS services;
- TNSDS-SAP for SDS.

NOTE: Although there are separate SAPs defined for CC and SS, the protocol description is based on the CC service primitives, which contain a mixture of CC and SS parameters.

CMCE shall obtain services from the underlying voice and data MLE through the LCMC-SAP.

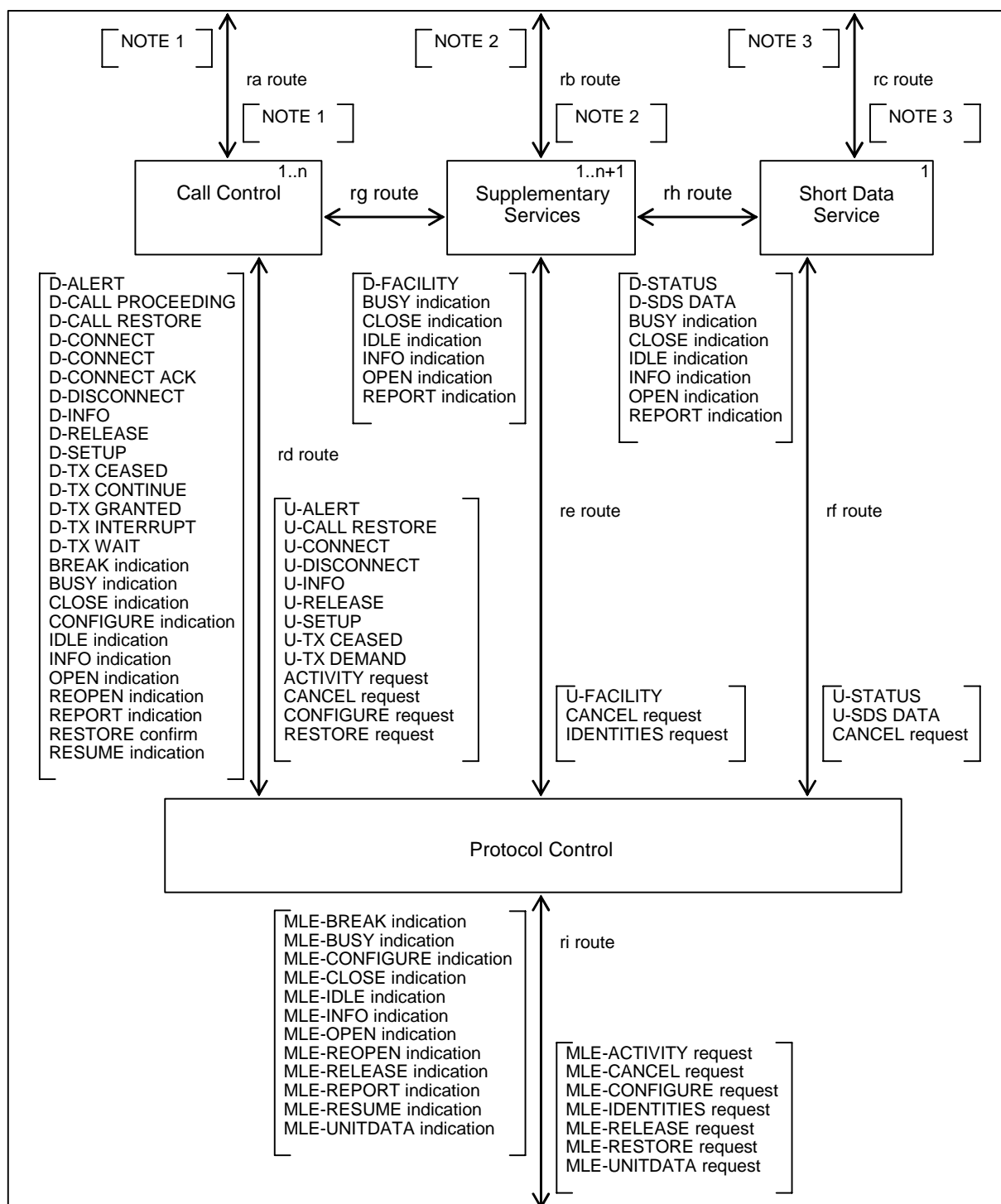
There shall be one instance of the CMCE entity per TSI family within the MS/LS.

The CMCE is internally subdivided into four different sub-entities:

- CC;
- SS;
- SDS; and
- Protocol Control (PC).

The information exchange between the CC and the SS sub-entities is defined in the supplementary service definitions. The structure is as shown in figure 19.





- NOTE 1: Service primitives for the TNCC-SAP are defined in clause 11.  
 NOTE 2: Service primitives for the TNSS-SAP are defined in clause 12.  
 NOTE 3: Service primitives for the TNSDS-SAP are defined in clause 13.

**Figure 19: Block view of CMCE-MS**

### 14.2.3 Addressing rules

In addition to the normal TSI which is used in different forms in the initial call set-up messages (ITSI, GTSI, SSI), the CMCE entity shall also use the call identifier for call handling.

The call identifier shall be used as a unique reference to a call between a call participant and the SwMI. A call identifier is allocated at call set-up time by the SwMI and the call identifier may be changed by the SwMI by allocating a new call identifier to the MS for the call. Once allocated, the call identifier shall be used in subsequent call related CMCE messages for that call.

The layer 3 air interface messages may contain only the SSI part of an address. The following rules define how the receiving entity shall, if it needs to do so, derive the MNI (i.e. convert the SSI to full ITSI or GTSI) if the MNI is not supplied over the air interface.

- The SwMI shall interpret the "Called party SSI" or "Other party SSI" on received uplink messages as belonging to the SwMI (i.e. the "missing" MNI is the MNI of the current network).
- The MS shall interpret the "Calling party address SSI" or "Transmitting party address SSI" on received downlink messages as belonging to the current SwMI (i.e. the "missing" MNI is the MNI of the current network).

NOTE 1: The MNI of the SwMI (MCC and MNC) is sent in the broadcast D-MLE-SYNC PDU, refer to clause 18.4.2.1.

NOTE 2: The first rule forces the MS to send the MNI over the air interface also when the called user address belongs to the home network of the MS and MS has migrated to a foreign network - edition 1 of the Dialling and Addressing Designer's Guide, ETR 300-5 [50], describes a different approach which is no longer valid.

NOTE 3: The second rule allows to use only SSI addressing so that all MSs in the same SwMI, independently of whether they are in their home or in a visited SwMI, will understand it in the same manner (for example group calls having participants belonging to different networks).

NOTE 4: The supplementary service related information in U/D-FACILITY PDU or in facility information element may use SSI differently, refer to supplementary service definitions.

NOTE 5: The visiting GSSI (V-GSSI) is used only as a layer 2 address in reception and also by MM in layer 3 PDUs in the group attachment/detachment procedures. V-GSSI shall not be used as "Called party SSI" or "Other party SSI" in CMCE PDUs.

NOTE 6: If a SwMI allocates a temporary address the MS will consider that the MNI of it is the one of the current SwMI.

### 14.2.4 CC, SS and SDS sub-entities

The CMCE model describes the protocol behaviour of CC, SS and SDS functional entities.

#### 14.2.4.1 CC sub-entity

The CC process is a functional sub-entity which provides a set of procedures for the establishment, maintenance and release of circuit switched services. It provides support for the TETRA basic call signalling. The CC shall manage invocation of the SS-Access Priority.

The CC process shall use the ra signalling route for communication with the user application (see clause 11) and the rd signalling route for communication with the protocol control process. The information exchange of SS related parameters needed for SS information exchange is not defined.

There can be multiple instances of CC per CMCE entity. Depending on its physical capabilities an MS may be able to support up to four active concurrent circuit mode calls at the same time.

#### 14.2.4.2 SS sub-entity

The SS process is a functional sub-entity which provides procedures for transfer of information related to SSs. The transfer of SS information is either call related or call unrelated.

The SS processes shall use the rb signalling route for communication with the user application over the TNSS-SAP (see clause 12) and the re signalling route for communication with the protocol control process. Internal communication between the CC process and the SS process is outside the scope of the present document.

SSs related to a call in progress shall have a fixed relationship with the corresponding CC entity instance and these SS instances shall cease to exist after the CC instance ceases to exist.

There shall be also a SS entity, which is not related to any calls in progress. That entity may use either a U/D-FACILITY PDU or any CC PDU, when appropriate, to exchange SS information between a MS and a SwMI. The facility field of the CC PDUs shall only be used to exchange SS information between a MS and the SwMI.

#### 14.2.4.3 SDS sub-entity

The SDS process shall be a functional sub-entity which provides procedures for transfer of short data and status messages. The SDS entity shall also manage invocation of the SS- Access Priority for the short data PDU exchange.

The SDS process shall use the rc signalling route for communication with the user application over the TNSDS-SAP (see clause 13) and the rf signalling route for communication with the protocol control process.

The SDS entity shall not be related to any call and it shall provide SDS services independently of whether the SDS message is directed to a user application involved in an active CC call, or not.

There shall only be one instance of SDS entity per CMCE entity.

#### 14.2.5 PC sub-entity

The PC sub-entity shall provide the following functionality:

- PC shall act as an upwards/downwards router by discriminating the upper sub-entities within CMCE. The analysis of the content of the various information elements in the PDUs shall be done by the sub-entity which is responsible for and owns the individual elements. Outgoing PDUs shall be routed to the MLE in primitives;
- PC shall ensure that there is only one mobile originated call set-up in progress at any one time by only allowing one CC sub-entity at a time to be actively setting up a call until SwMI allocates a call identifier to that call or the call set-up is discarded;
- MLE shall give indications of the progress of the PDU transmission to PC by MLE-REPORT indications. PC shall be responsible for handling of general error procedures for the CMCE protocol;
- PC shall use the signalling routes rd, re, rf for communication with the CC, SS and SDS sub-entities, and the ri signalling route for communication with the MLE over the LCMC-SAP;
- there shall only be one instance of PC per CMCE entity.

## 14.2.6 Internal routes

The PDUs and local primitives are grouped per each sub-entity and internal route.

From PC to CC on rd route:

- D-ALERT;
- D-CALL-PROCEEDING;
- D-CALL-RESTORE;
- D-CONNECT;
- D-CONNECT ACKNOWLEDGE;
- D-DISCONNECT;
- D-INFO;
- D-RELEASE;
- D-SETUP;
- D-TX-CEASED;
- D-TX-CONTINUE;
- D-TX-GRANTED;
- D-TX-INTERRUPT;
- D-TX-WAIT;
- BREAK indication;
- BUSY indication;
- CLOSE indication;
- CONFIGURE indication;
- IDLE indication;
- INFO indication;
- OPEN indication;
- REOPEN indication;
- REPORT indication;
- RESTORE confirm;
- RESUME indication.

From CC to PC on rd route:

- U-ALERT;
- U-CALL-RESTORE;
- U-CONNECT;
- U-DISCONNECT;
- U-INFO;

- U-RELEASE;
- U-SETUP;
- U-TX-CEASED;
- U-TX-DEMAND;
- ACTIVITY request;
- CANCEL request;
- CONFIGURE request;
- RESTORE request.

From PC to SS on re route:

- D-FACILITY;
- BUSY indication;
- CLOSE indication;
- IDLE indication;
- INFO indication;
- OPEN indication;
- REPORT indication.

From SS to PC on re route:

- U-FACILITY;
- IDENTITIES request;
- CANCEL request.

NOTE 1: U/D-FACILITY PDUs are used to transport SS information, which is not related to any ongoing call or related to a call during SS-CC retention time after the call.

NOTE 2: SS information, which relates to an ongoing call is transported either as a predefined element in a CC PDU or as a facility element in a CC or in a U/D-INFO PDU (see clause 14.7).

From PC to SDS on rf route:

- D-STATUS;
- D-SDS-DATA;
- BUSY indication;
- CLOSE indication;
- IDLE indication;
- INFO indication;
- OPEN indication;
- REPORT indication.

From SDS to PC on rf route:

- U-STATUS;
- U-SDS-DATA;
- CANCEL request.

## 14.2.7 Intra-CMCE primitive summary

The sub-entities inside CMCE shall be responsible for setting parameters in each PDU it is sending. These parameters are used in the lower layers in the transmission process. These parameters are not visible outside the MS protocol stack, but shall affect to the functions inside the protocol stack.

### 14.2.7.1 Down link CC PDU parameters

The following parameters shall accompany each PDU in addition to the PDU contents (SDU). The contents of the SDUs are defined in clause 14.7. These parameters shall be valid for rd route (see clause 17.3.4 for ri route parameters):

- received TETRA address;
- received address type;
- channel change response required.

The D-CALL RESTORE PDU should be a SDU in the RESTORE confirm primitive and the parameters used in this primitive shall be:

- SDU;
- restoration result.

### 14.2.7.2 Uplink CC PDU parameters

Each PDU shall convey following information as parameters in addition to the PDU contents. The contents of the PDUs are defined in clause 14.7. These parameters shall be valid for rd route (see clause 17.3.4 for ri route parameters):

- endpoint identifier;
- layer 2 service;
- PDU priority;
- stealing permission;
- stealing repeats flag.

The MS shall send the U-RESTORE REQUEST PDU as an SDU in the RESTORE request primitive.

The parameters used in this primitive shall be:

- SDU;
- layer 2 service;
- PDU priority;
- stealing permission;
- stealing repeats flag.

### 14.2.7.3 Downlink SS PDU parameters

Each PDU shall convey following information as parameters in addition to the PDU contents. The contents of the PDUs are defined in clause 14.7. These parameters shall be valid for re route (see clause 17.3.4 for ri route parameters):

- channel change response required;
- received TETRA address;
- received address type.

### 14.2.7.4 Uplink SS PDU parameters

Each PDU shall convey following information as parameters in addition to the PDU contents. The contents of the PDUs are defined in clause 14.7. These parameters shall be valid for re route (see clause 17.3.4 for ri route parameters):

- layer 2 service;
- PDU priority;
- stealing permission.

### 14.2.7.5 Down link SDS PDU parameters

Each PDU shall convey following information as parameters in addition to the PDU contents. The contents of the PDUs are defined in clause 14.7. These parameters shall be valid for rf route (see clause 17.3.3 for ri route parameters):

- received TETRA address;
- received address type.

### 14.2.7.6 Uplink SDS PDU parameters

Each PDU shall convey following information as parameters in addition to the PDU contents. The contents of the PDUs are defined in clause 14.7. These parameters shall be valid for rf route (see clause 17.3.4 for ri route parameters):

- layer 2 service;
- PDU priority;
- stealing permission.

### 14.2.7.7 CMCE management primitives

#### 14.2.7.7.0 ACTIVITY request

The parameter used in this primitive shall be:

- call state (see clause 17.3.9).

#### 14.2.7.7.1 BREAK indication

There are no parameters associated with this primitive.

#### 14.2.7.7.1a BUSY indication

There are no parameters associated with this primitive.

#### 14.2.7.7.2 CANCEL request

The parameter used in this primitive shall be:

- handle.

#### 14.2.7.7.3 CLOSE indication

There are no parameters associated with this primitive.

#### 14.2.7.7.4 CONFIGURE indication

The parameters used in this primitive shall be:

- endpoint identifier;
- endpoint status.

#### 14.2.7.7.5 CONFIGURE request

The parameters used in this primitive shall be:

- add temporary GSSI;
- circuit mode type (see clause 14.8.2);
- channel change accepted (see clause 17.3.9);
- leave assigned channel;
- delete temporary GSSI;
- encryption flag;
- call identifier;
- endpoint identifier;
- simplex/duplex;
- slots per frame;
- switch U-plane on/off;
- Tx grant.

#### 14.2.7.7.6 IDENTITIES request

The parameter used with this primitive shall be:

- list of attached GSSIs;
- list of detached GSSIs.

#### 14.2.7.7.6a IDLE indication

There are no parameters associated with this primitive.



#### 14.2.7.7.6b INFO indication

The parameters used with this primitive shall be:

- broadcast parameters (see clause 17.3.9);
- subscriber class match (see clause 17.3.9).

#### 14.2.7.7.7 OPEN indication

There are no parameters associated with this primitive.

#### 14.2.7.7.8 REOPEN indication

There are no parameters associate with this primitive.

#### 14.2.7.7.9 REPORT indication

The parameter used in this primitive shall be:

- transfer result.

#### 14.2.7.7.10 RESUME indication

There are no parameters associated with this primitive.

### 14.3 Overview of services required by the CMCE

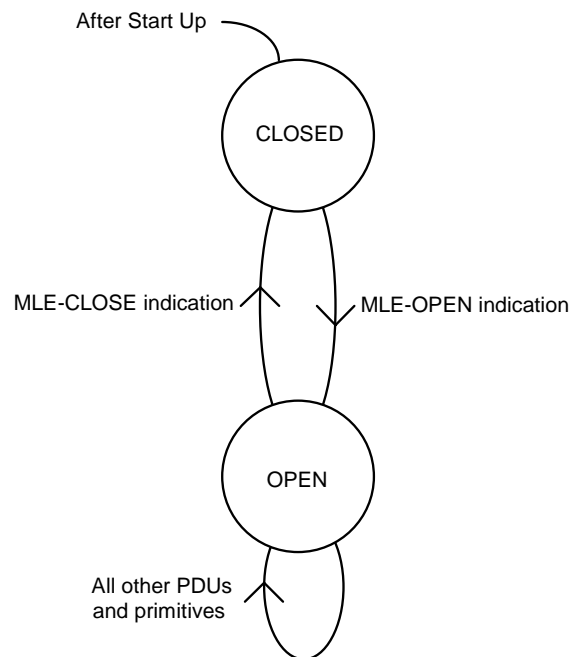
In order to transfer messages over the air interface, CMCE shall use the services of the MLE, which in turn shall rely on the service from underlying layers. The services required from MLE shall be as described in clause 17.

### 14.4 CMCE protocol states

CMCE shall comprise 4 sub-entities each of them having a separate state transition diagram as shown in figures 20, 21, 22 and 23.

Only the main states are shown.

### 14.4.1 States for PC



**Figure 20: State transition diagram for the PC sub-entity**

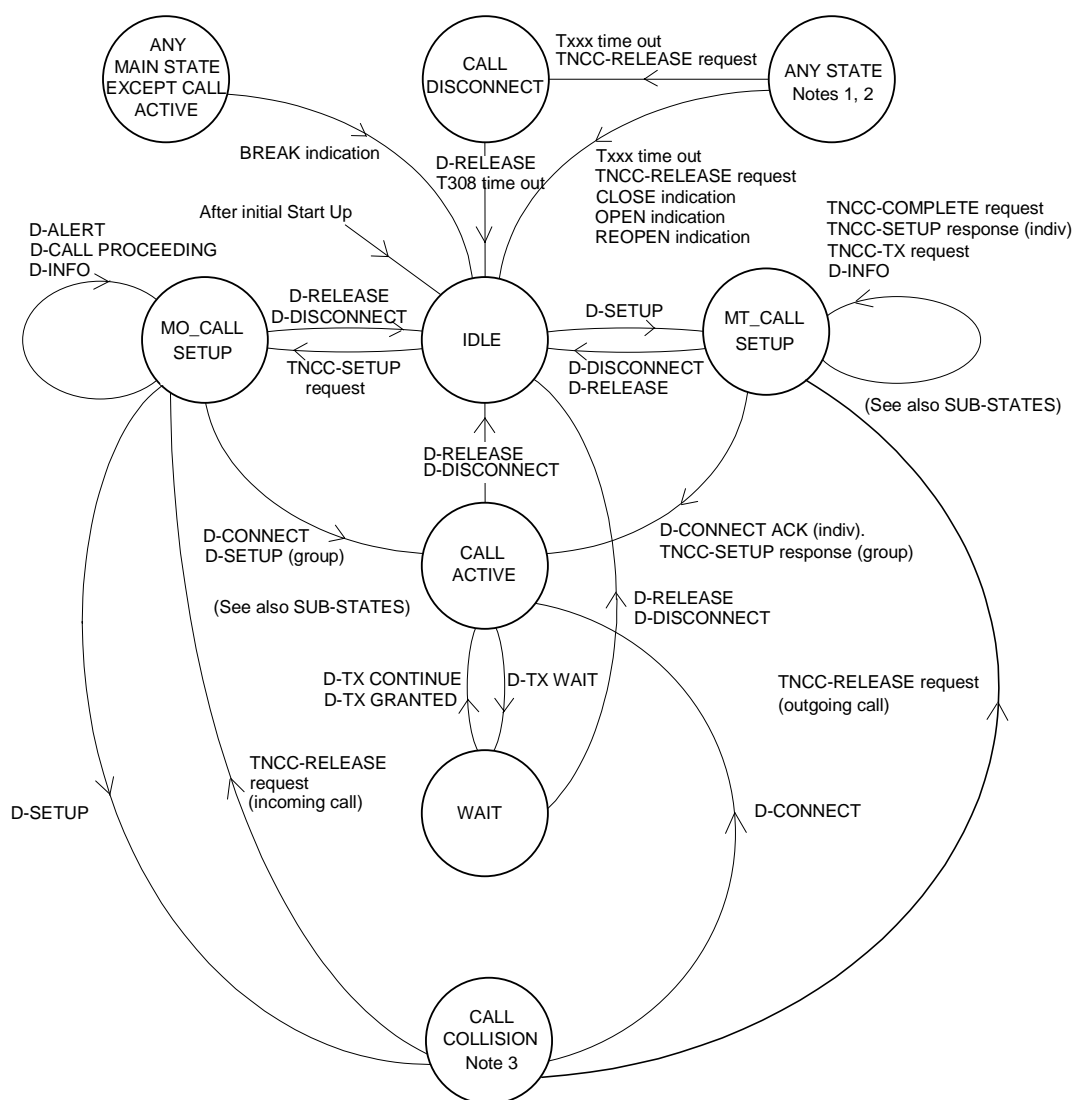
#### 14.4.1.1 CLOSED

This state exists after an MLE-CLOSE indication has been received from the MLE indicating that access to communication resources is no longer allowed and the PC sub-entity shall inform the CC, SS and SDS sub-entities with CLOSE indications. The PC sub-entity shall also enter state CLOSED after initial start up.

#### 14.4.1.2 OPEN

This is the normal state and indicates that a communication path to a peer entity is open. It is set after an MLE-OPEN indication has been received from the MLE. When PC receives a MLE-OPEN indication and goes to state OPEN, the CC, SS and SDS sub-entities shall be informed with OPEN indications.

## 14.4.2 States for CC



NOTE 1: The TNCC-RELEASE request transitions from the state "ANY STATE" are not applicable for the "CALL COLLISION" state.

NOTE 2: The selection of the TNCC-RELEASE request transition from the state "ANY STATE" is dependent on the need for sending disconnection message over the air interface, refer to clauses 14.5.1.1.3 and 14.5.2.1.3.

NOTE 3: The TNCC-RELEASE request transitions from CALL COLLISION state present interactions between two call control instances and show a simplified view, refer to clauses 14.5.1.1.3 and 14.5.2.1.3.

**Figure 21: State transition diagram for the CC sub-entity**

A further subdivision of the main states MT-CALL-SETUP and CALL-ACTIVE belonging to the CC sub-entity may be considered as detailed in figures 22 and 23.

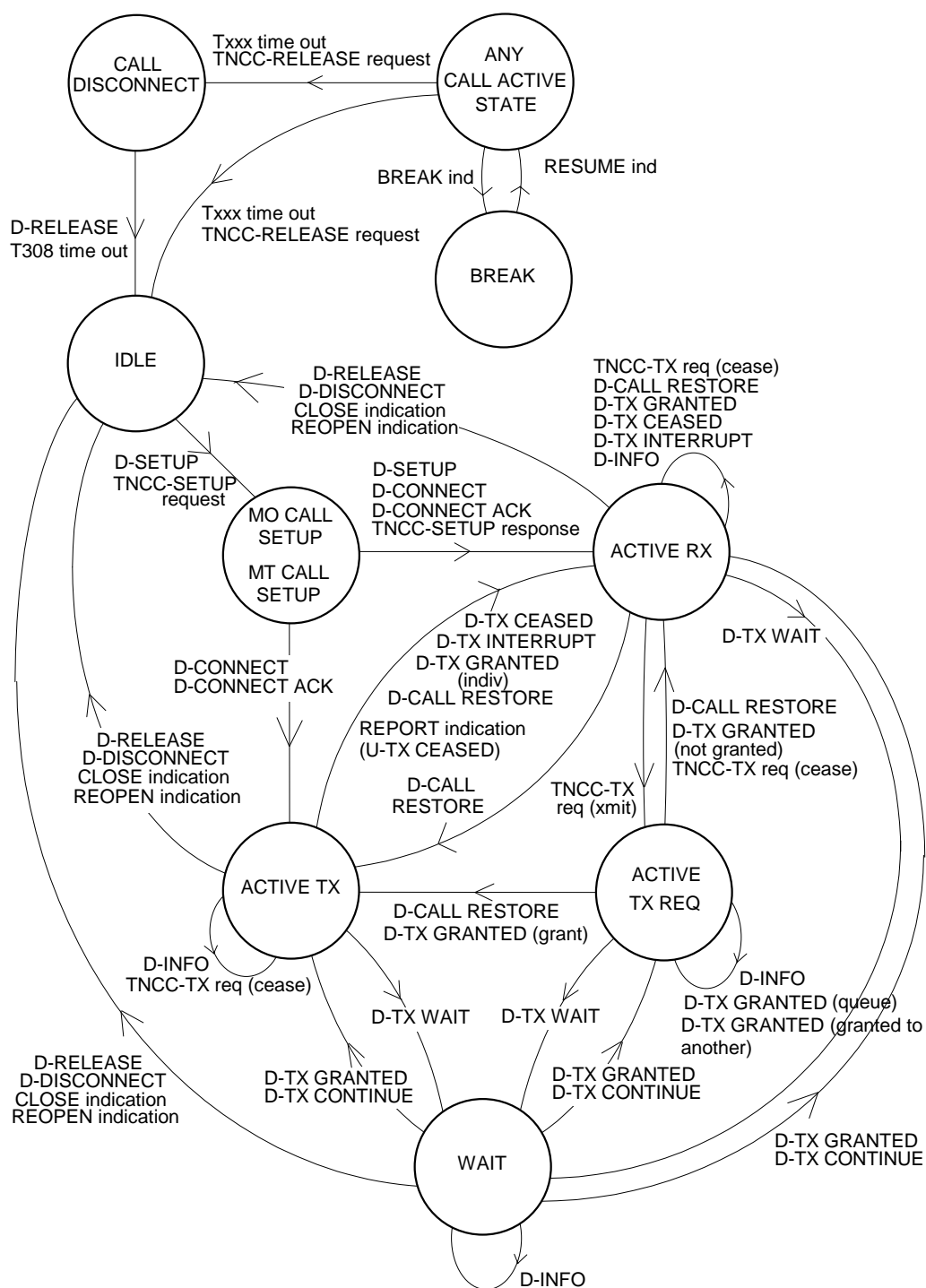
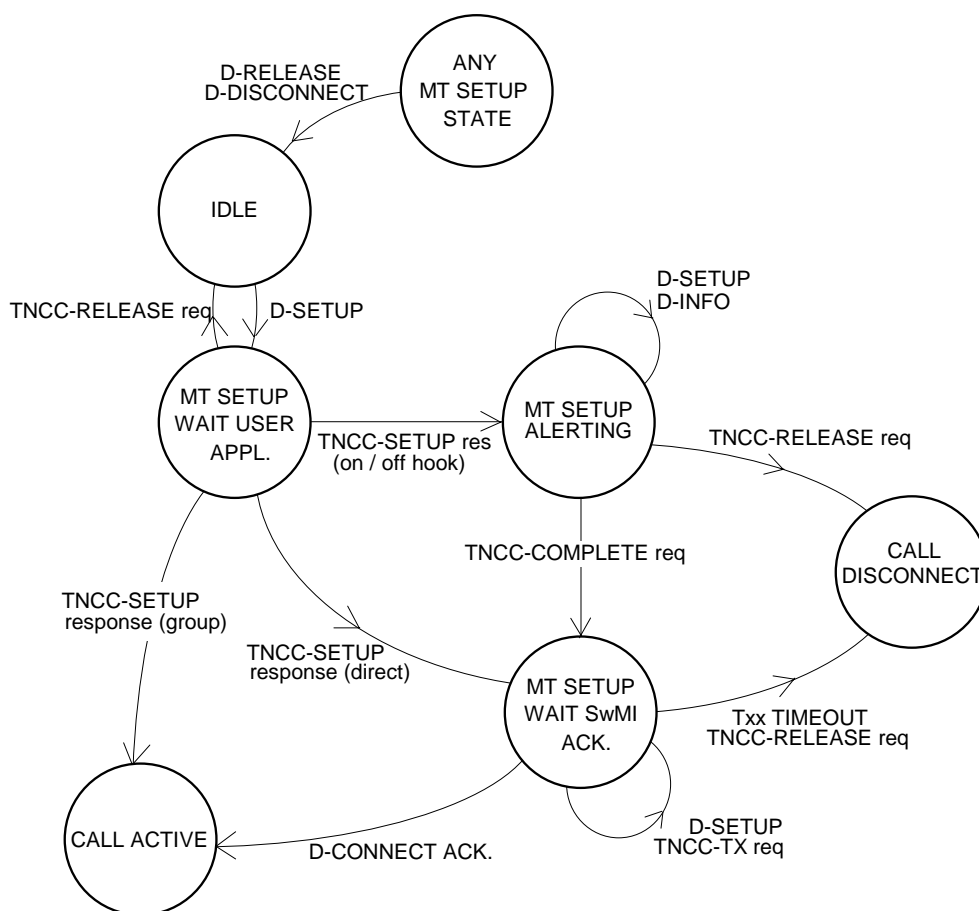


Figure 22: Sub state transition diagram for the CALL-ACTIVE state



**Figure 23: Sub state transition diagram for the MT-CALL-SETUP state**

#### 14.4.2.1 IDLE

This is the normal state when no calls exist and indicates that the CC sub-entity is available to handle a call set-up. This is the state that CC shall enter after initial start up.

**NOTE:** Any transition to or from the IDLE state should be accompanied with the generation of an **ACTIVITY** request primitive (see clause 14.2.7.7.0), containing the appropriate call state, to the PC entity.

#### 14.4.2.2 MO-CALL-SETUP

This state exists when a MS/LS originated call set-up has been initiated but the call has not been established. It exists after a U-SETUP PDU has been sent as the result of the receipt of a TNCC-SETUP request until a D-CONNECT PDU is received indicating that the call set-up is successful. If the call set-up is unsuccessful or the user application disconnects the call the CC sub-entity shall leave this state.

#### 14.4.2.3 MT-CALL-SETUP

This state exists during a call set-up where the CC sub-entity is the call terminating CC sub-entity. It exists after the receipt of a D-SETUP PDU, until the receipt of a D-CONNECT ACKNOWLEDGE PDU, for point-to-point calls only, or receipt of a TNCC-SETUP response for point-to-multipoint calls only. The MT-CALL SETUP state is also left if the call set-up is unsuccessful, or if the user application rejects the call.

#### 14.4.2.4 CALL ACTIVE

This state exists when the call has been established.

NOTE: Transitions between the ACTIVE RX and ACTIVE TX sub-states should be accompanied with the generation of an ACTIVITY request primitive (see clause 14.2.7.7.0), containing the appropriate call state, to the PC entity.

#### 14.4.2.5 CALL DISCONNECT

This state exists when an established call is in the progress of disconnecting. It exists after the receipt of a TNCC-RELEASE request from the user application, or if a timer initiated disconnection occurs, until either a D-RELEASE PDU is received, or the call disconnect timer expires.

#### 14.4.2.6 WAIT

The state exists if there is a temporary interruption to the call. The CC shall enter this state upon receipt of a D-TX-WAIT PDU and remain in this state until a D-TX-CONTINUE PDU or D-TX GRANTED PDU is received, or the call is disconnected.

### 14.4.3 States for SS

There shall only exist 2 general generic states for the SS sub-entity. Each individual service shall then have its own state transition diagrams associated with its protocol.

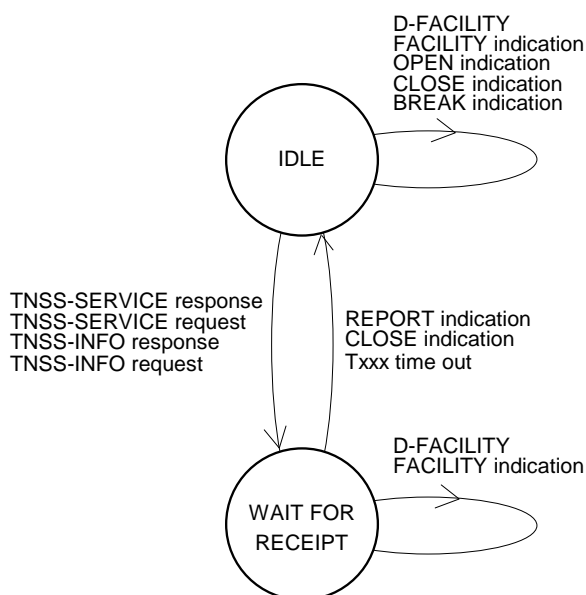
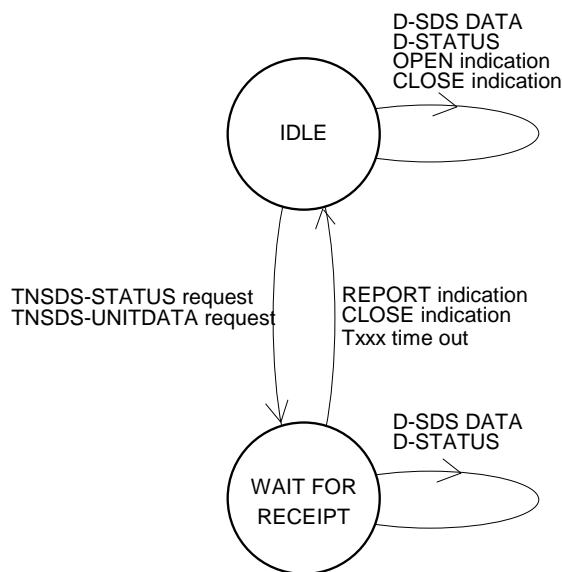


Figure 24: State transition diagram for the SS sub-entity

## 14.4.4 States for SDS

There shall only exist 2 generic states for the SDS sub-entity.



**Figure 25: State transition diagram for the SDS**

## 14.5 Procedures

In this protocol the routing of PDUs and primitives is implicit by the PDU and primitive name as defined in clause 14.2.

The timers in the following procedures are:

- started - meaning that the timer shall start to measure time as indicated in the parameter value T3xx independently of the current timer count; or
- stopped - meaning that the timer shall be stopped at the current timer count; or
- reset - meaning that the timer count shall be set to its initial value, be it zero or parameter value T3xx.

Depending on timer T3xx the starting value shall either be pre-defined or dynamically set by air interface protocol procedures.

NOTE 1: In IDLE state all timers T3xx are stopped and whenever a timer is started it will get a proper value as stored, or from a PDU as appropriate.

NOTE 2: There is no call identifier associated to a CC instance in IDLE state.

### 14.5.1 Individual CC procedures

The CC procedures handled by the CC sub-entity shall be applicable for both speech and data circuit mode calls. Individual speech and data circuit mode calls shall be set-up as point-to-point calls. The specification shall be applicable for the procedures and states that reside in the MS/LS.

14.5.1.1 Call set-up procedures

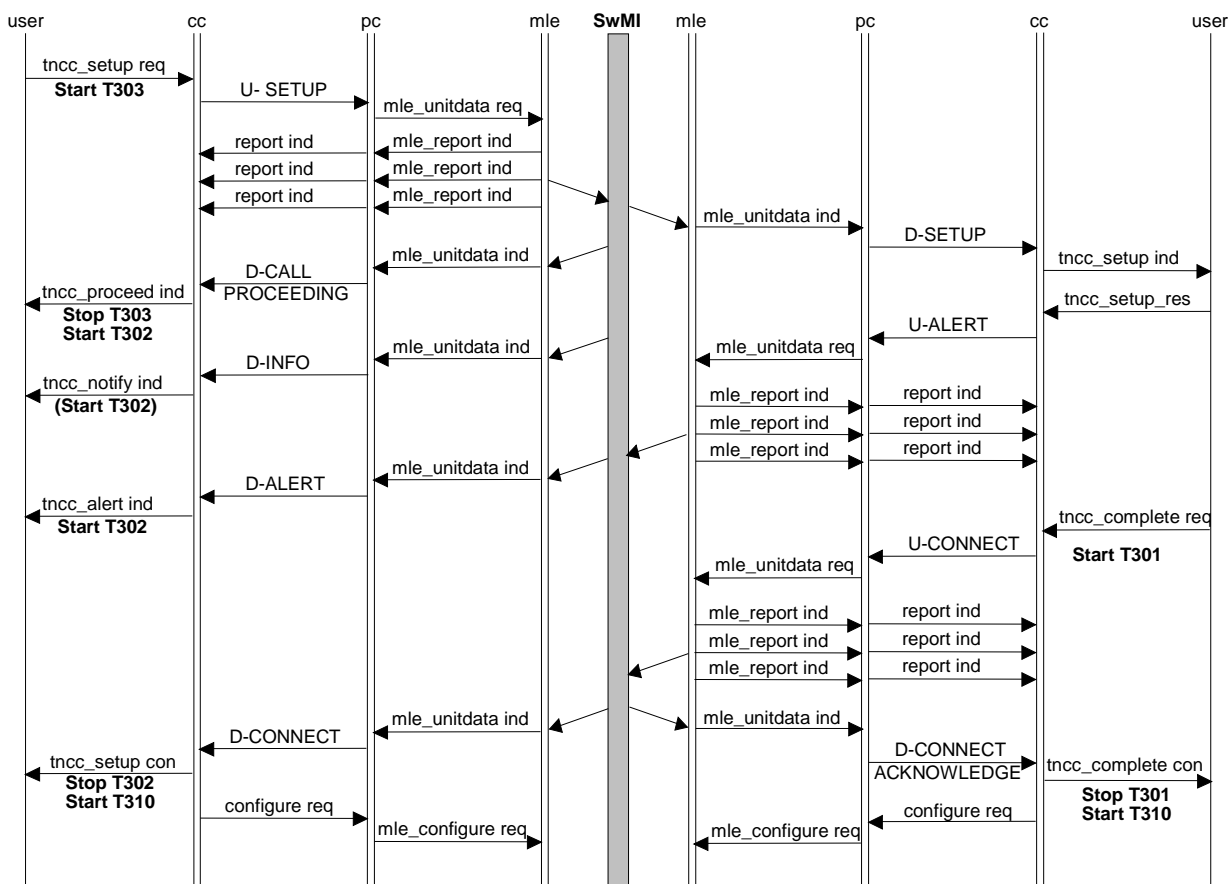


Figure 26: Individual call set-up scenario using on/off hook signalling

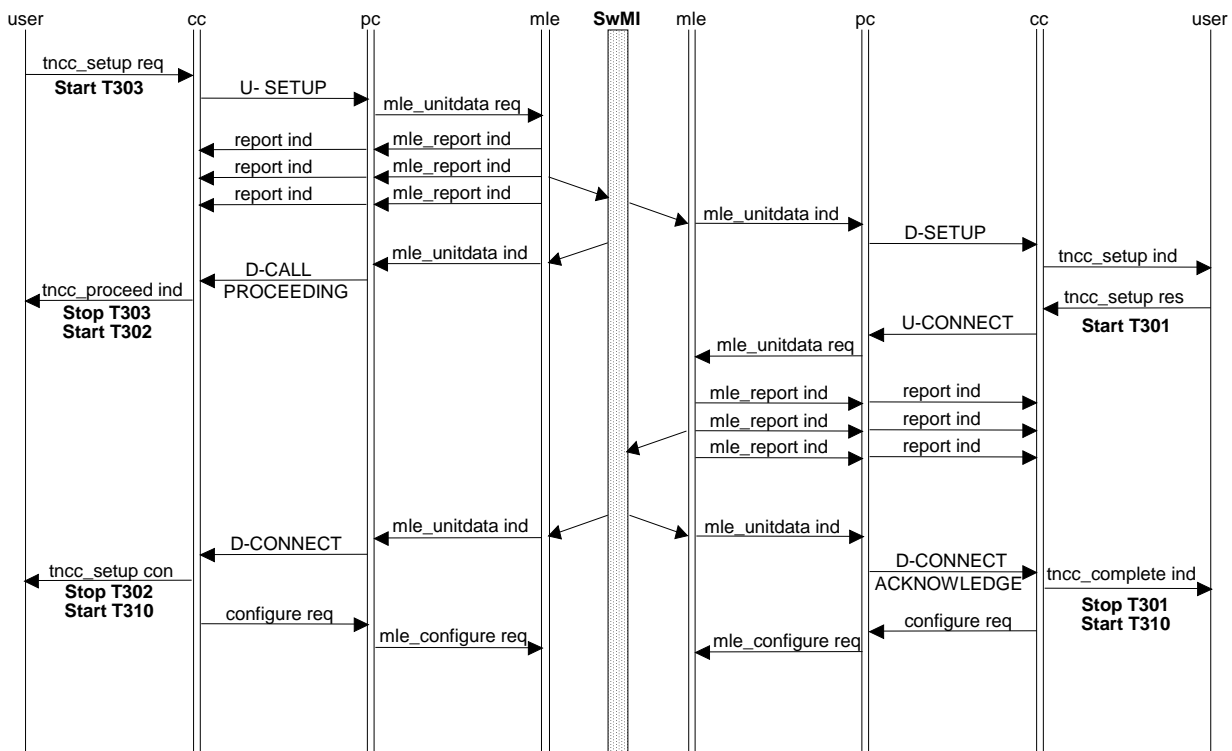


Figure 27: Individual call set-up scenario using direct set-up signalling



### 14.5.1.1.1 Incoming call

Notification of the arrival of an incoming call to the CC sub-entity shall be made by the reception of a D-SETUP PDU which shall be delivered to the user application in a TNCC-SETUP indication via the TNCC-SAP. If the user application can support the call it shall immediately return a TNCC-SETUP response otherwise it shall return a TNCC-RELEASE request (see clause 14.5.1.1.5).

On receipt of a D-SETUP PDU the CC sub-entity shall enter state MT-CALL-SETUP and take the following actions, which are dependent upon the information contained within the D-SETUP PDU:

- the call identifier shall be used as the reference to this call in subsequent PDUs during the call;
- it shall be indicated to the called MS/LS in the D-SETUP PDU if on/off hook signalling or direct set-up signalling is used for this call set-up;
- if on/off hook signalling is requested and the CC receives a TNCC-SETUP response indicating that the called user application has accepted on/off hook signalling, the CC shall send a U-ALERT PDU indicating that the called party is alerted, see figure 26 right hand side. The CC sub-entity shall remain in state MT-CALL-SETUP;
- when on/off hook signalling is used and the CC receives a TNCC-COMPLETE request indicating that the called user application has answered, the CC shall send a U-CONNECT PDU and start timer T301. The CC sub-entity shall remain in state MT-CALL-SETUP. Upon receipt of a D-CONNECT ACKNOWLEDGE PDU, the CC shall inform the user application with a TNCC-COMPLETE confirm, enter state CALL-ACTIVE, stop timer T301 and start timer T310, see figure 26 right hand side. The D-CONNECT-ACKNOWLEDGE PDU shall contain an indication as to which party is permitted to transmit. The CC sub-entity shall send a CONFIGURE request for lower layer configuration;
- in a duplex call the SwMI shall grant permission to talk in the D-CONNECT ACKNOWLEDGE PDU;
- if direct set-up signalling is used and the CC receives a TNCC-SETUP response indicating that the called user application has accepted direct call set-up signalling, the CC shall send a U-CONNECT PDU indicating that the MS/LS is ready for immediate communication, and shall start timer T301. Upon receipt of the U-CONNECT message the SwMI should send a D-CONNECT ACKNOWLEDGE PDU in return. The CC sub-entity shall then inform the user application with a TNCC-COMPLETE indication and shall enter state CALL-ACTIVE, stop timer T301 and start timer T310, see figure 27 right hand side. The D-CONNECT ACKNOWLEDGE PDU shall contain an indication as to which party is permitted to transmit. The CC sub-entity shall send a CONFIGURE request for lower layer configuration;
- if transmission is not granted but the D-CONNECT ACKNOWLEDGE PDU contains an indication that the MS/LS is allowed to request transmission permission, the CC shall follow the transmission control procedures outlined in clause 14.5.1.2.1;
- where the called MS/LS is unable to accept the request for a basic service, it may according to the rules stated below, offer a different basic service to the calling party. The offered value shall be indicated in the U-CONNECT or U-ALERT PDU. Where the called MS/LS is unable to offer a different service according to the rules below then the call shall be rejected using a U-DISCONNECT PDU as defined in clause 14.5.1.1.5, e.g. if circuit mode data is requested but the terminal cannot support data.
- for circuit mode unprotected bearer services:
  - if 28,8 kbit/s requested, 21,6 kbit/s, 14,4 kbit/s or 7,2 kbit/s may be offered;
  - if 21,6 kbit/s requested, 14,4 kbit/s or 7,2 kbit/s may be offered;
  - if 14,4 kbit/s requested, 7,2 kbit/s may be offered.
- for circuit mode protected (low) bearer services:
  - if 19,2 kbit/s requested, 14,4 kbit/s, 9,6 kbit/s or 4,8 kbit/s may be offered;
  - if 14,4 kbit/s requested, 9,6 kbit/s or 4,8 kbit/s may be offered;
  - if 9,6 kbit/s requested, 4,8 kbit/s may be offered;

- if interleaving depth  $N = 8$  requested,  $N = 4$  or  $N = 1$  may be offered;
- if interleaving depth  $N = 4$  requested,  $N = 1$  may be offered.
- for circuit mode protected (high) bearer services:
  - if 9,6 kbit/s requested, 7,2 kbit/s, 4,8 kbit/s or 2,4 kbit/s (high) may be offered;
  - if 7,2 kbit/s requested, 4,8 kbit/s or 2,4 kbit/s (high) may be offered;
  - if 4,8 kbit/s requested, 2,4 kbit/s (high) may be offered;
  - if interleaving depth  $N = 8$  requested,  $N = 4$  or  $N = 1$  may be offered;
  - if interleaving depth  $N = 4$  requested,  $N = 1$  may be offered.
- if the called MS/LS is requested to support a duplex call and is unable to do so, then it shall offer a simplex call by setting the simplex/duplex element accordingly in either the U-ALERT or U-CONNECT PDU;
- if the called MS is requested to use direct call set-up and it is unable to support this, but does support on/off hook signalling, then it shall offer this service by sending the U-ALERT PDU;
- if the called MS is requested to use on/off hook signalling and is unable to support this, but does support direct call set-up, then it shall offer this service by setting the hook method element accordingly in the U-CONNECT PDU;
- if the called user application during the call set-up cannot continue to support of the call for other reasons that those stated above the request for call set-up shall be rejected by issuing a TNCC-RELEASE request. The request to release the call set-up shall be mapped to a U-DISCONNECT PDU and follow the procedure defined in clause 14.5.1.3.

During the call set-up phase, the SwMI may send the D-INFO PDU containing a new value for T301 to prolong the call set-up time. If the CC in the called MS/LS receives an D-INFO PDU containing a Call time-out, set-up phase element the CC shall start timer T301 using the specified value.

#### 14.5.1.1.2 Outgoing call

To initiate the call establishment, the user application shall transfer a TNCC-SETUP request primitive across the TNCC SAP to the CC sub-entity. The TNCC-SETUP request shall be handled by a CC sub-entity instance that is in state IDLE.

The CC shall select a PDU priority based on the requested access priority value as defined in clause 14.5.6.2. The CC shall convert the TNCC-SETUP request into a corresponding U-SETUP PDU and send it. The CC sub-entity shall then enter the MO-CALL-SETUP state and start timer T303.

The following describes the normal call set-up procedures:

- The progress of the transmission of the U-SETUP PDU may be reported to the CC in one or more REPORT indications. If the PDU transfer has failed, the CC shall stop timer T303, inform the user application with a TNCC-RELEASE indication and return to state IDLE.
- The SwMI may respond to the receipt of the U-SETUP PDU with a D-CALL PROCEEDING PDU indicating that the SwMI has received all information concerning the call set-up necessary to effect the call establishment. On reception of the PDU, the CC shall inform the user application with a TNCC-PROCEED indication. In the case where On/Off Hook Signalling is requested or the called user application selects that method and alerting information is ready at the time when the D-CALL PROCEEDING PDU should have been sent, the SwMI may respond with a D-ALERT PDU instead of the D-CALL-PROCEEDING PDU. Also if the call through connection is ready at the time when the D-CALL PROCEEDING PDU should have been sent, the SwMI may send a D-CONNECT PDU instead. On receipt of any of the above PDUs, Timer T303 shall be stopped, see figure 26 left hand side.
- The D-CALL PROCEEDING, D-ALERT or D-CONNECT PDU shall contain a Call Identifier which shall be used as the reference to this call in subsequent PDUs for the duration of the call.
- The D-INFO PDU shall not be used to allocate a call identifier.

- On reception of the D-CALL-PROCEEDING PDU the CC shall start timer T302, see figure 26 left hand side. The CC sub-entity shall remain in state MO-CALL-SETUP.
- If on/off hook signalling is requested and the CC receives a D-ALERT PDU, the CC shall inform the user application by issuing a TNCC-ALERT indication.
- On reception of a D-ALERT PDU, the timer T302 shall be started using the specified value, see figure 26 left hand side.
- During the call set-up phase, the SwMI may send the D-INFO PDU containing a new T302 to prolong the call set-up time. Upon reception of a D-INFO PDU containing Call time out, set-up phase element, the timer T302 shall be started using the specified value.
- In a duplex call the SwMI shall grant permission to talk in the D-CONNECT PDU.
- When a D-CONNECT PDU is received, the CC shall send a CONFIGURE request for lower layer configuration and inform the user application with a TNCC-SETUP confirm and enter state CALL-ACTIVE. The timer T302 shall be stopped, and timer T310 shall be started, see figure 26 left hand side. The D-CONNECT PDU shall contain an indication which party is permitted to transmit.
- If transmission is not granted but the D-CONNECT PDU contains an indication that the MS/LS is allowed to request transmission permission it shall follow the transmission control procedures defined in clause 14.5.1.2.1;
- Where the D-CALL PROCEEDING, D-CONNECT or the D-ALERT PDU indicates that the offered service is different to the one requested, and if the service offered is acceptable to the user application, the call shall continue. If the service is not acceptable, then the user application shall disconnect the call and the CC shall enter IDLE state, refer to clause 14.5.1.3.

**EXAMPLE:** If the user application has requested a 28,8 kbit/s circuit mode data, but considers that any data rate equal to or greater than 14,4 kbit/s is acceptable, then if a data rate of 14,4 kbit/s is offered the call shall continue. If a data rate of less than 14,4 kbit/s is offered (i.e. 7,2 kbit/s) then the user application shall disconnect the call.

**NOTE:** Handling of the TNCC-SETUP request primitive may be affected by the MS being active in a MM procedure, this being indicated to CC from MLE via the MLE-BUSY indication primitive, refer to clause 18.3.5.4. The exact nature of the interaction between MM/MLE and CC is outside the scope of this part of the present document but it is recommended that CC not accept a TNCC-SETUP request while MM is busy.

#### 14.5.1.1.3 Colliding calls

Call collisions can occur when both the SwMI and the MS/LS simultaneously send a D/U-SETUP PDU. Two call set-ups are colliding when a D-SETUP PDU is received within the window where the CC waits for a Call Identifier from the SwMI after a U-SETUP PDU has been issued. If this occurs and the MS/LS cannot support more concurrent calls, the MS/LS shall behave as follows:

- if the MS wishes to keep its own call attempt then it shall respond to the incoming call with a U-DISCONNECT PDU with a disconnect cause "called party busy"; or
- if the MS wishes to accept the incoming call then the CC shall accept the call as defined in clause 14.5.1.1.1. The CC shall also send a CANCEL request to the lower layers to cancel the sending of the U-SETUP PDU. If the lower layers indicate that the PDU has already been completely sent, then the CC shall send a U-DISCONNECT PDU for its own call set-up.

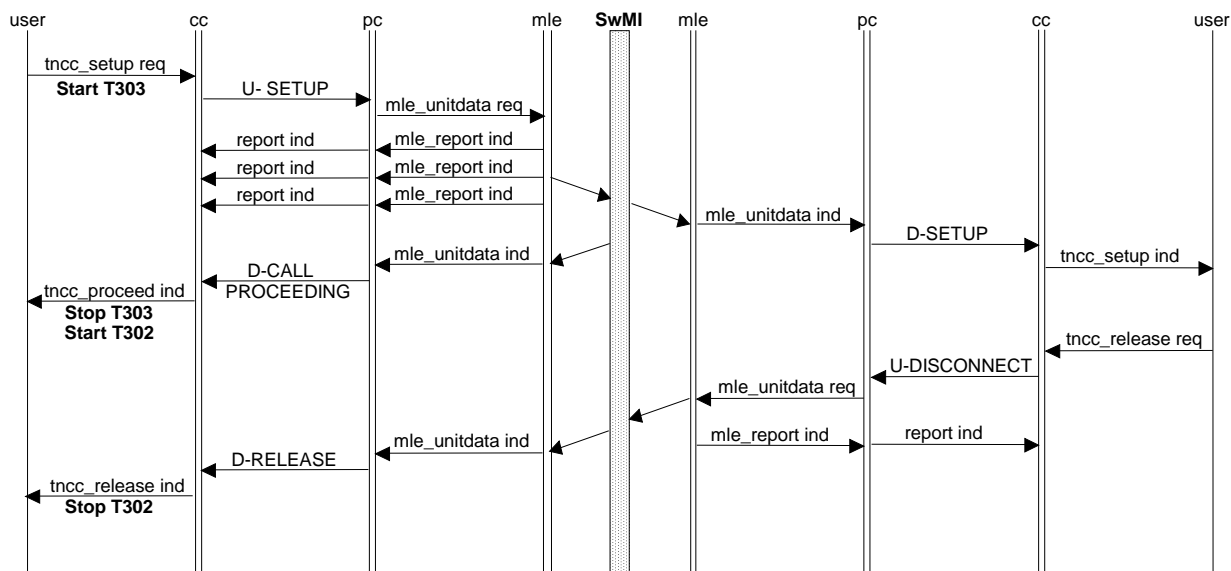
Another case of call collision may sometimes be detected and resolved by the SwMI. If the colliding calls are call set-up attempts between the same user applications and the requested basic services are the same, then the SwMI may merge the calls. The SwMI should inform both parties by a D-CONNECT PDU with an amalgamation indication that the calls are merged together, see the call ownership element. The CC should pass this information on to the application in the TNCC-SETUP confirm.

#### 14.5.1.1.4 Unsuccessful call set-up

Unsuccessful call set-up shall refer specifically to those instances where a circuit mode connection was not successfully established. It shall not refer to call disconnection or call rejection. If a PDU is not responded to prior to the expiry of the corresponding timer the procedure in clause 14.5.1.3.4. shall apply. All timers available are listed in clause 14.6.

When CC receives a REPORT indication, indicating that the lower layers have not been successful (failed transfer) in the sending of any of the call set-up PDUs, then the CC sub-entity shall return to state IDLE and shall inform the user application with a TNCC-RELEASE indication accompanied with a cause of the disconnection.

#### 14.5.1.1.5 Call rejection



**Figure 28: Individual call set-up phase - called user application rejects the call**

If the user application cannot accept an incoming call as defined in 14.5.1.1.1, it shall immediately transfer a TNCC-RELEASE request to the CC sub-entity. The CC sub-entity shall send a U-DISCONNECT PDU along with the disconnection cause "Call Rejected by the called party", see figure 28. In case the rejection results from unsupported encryption flag state the disconnect cause shall be "Called party does not support encryption" or "Called party requires encryption". The CC sub-entity shall then change to state IDLE.

**NOTE:** If the SwMI sends the D-RELEASE PDU as the first response to the calling MS, then it should contain the dummy call reference.

For the busy case refer to clause 14.5.6.5.3.

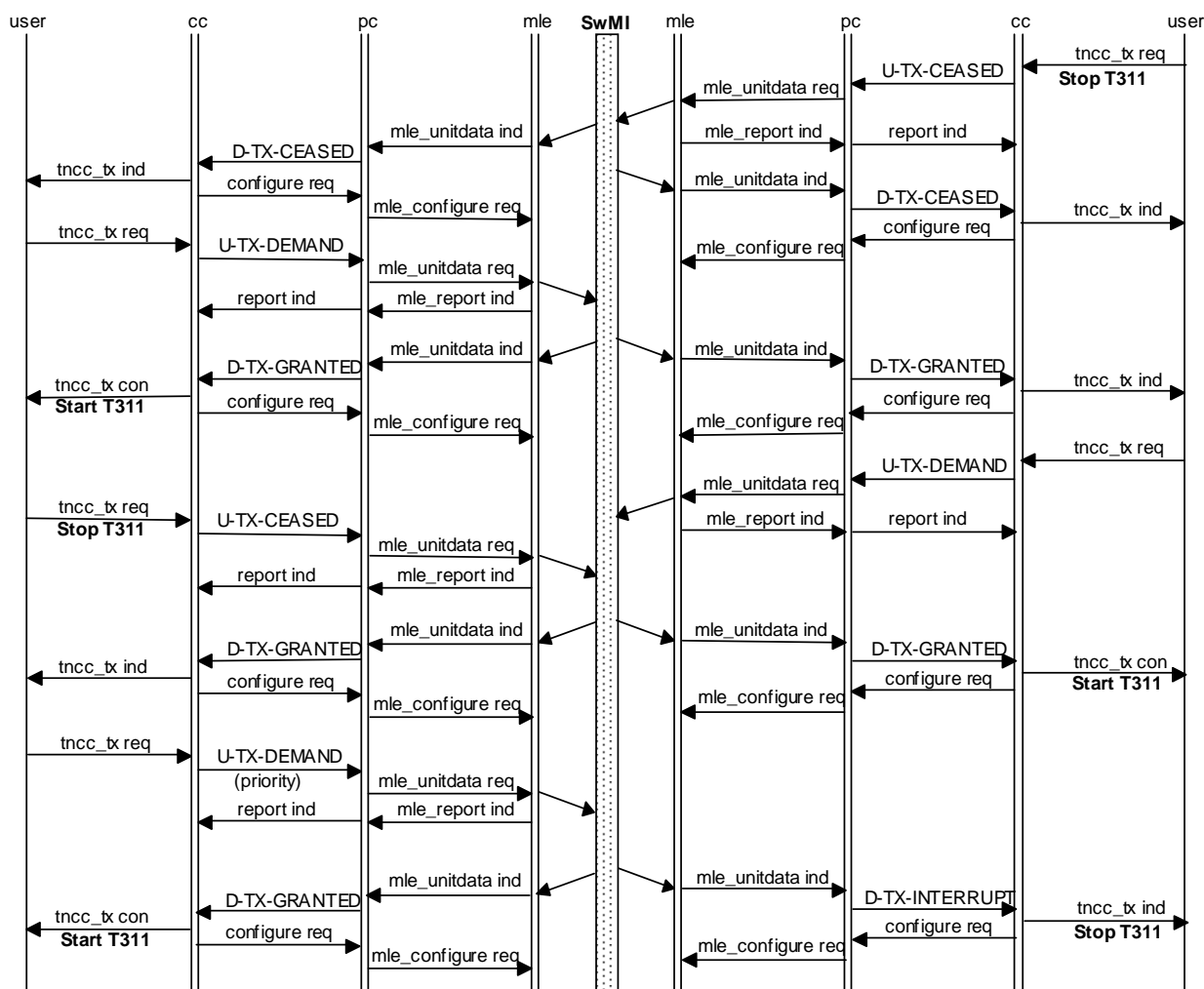
#### 14.5.1.2 Call maintenance procedures

The call maintenance procedures described in this clause may be applied when the MS/LS is in states MO-CALL SETUP, MT-CALL SETUP or CALL-ACTIVE. The main state CALL-ACTIVE can comprise several sub-states which are presented in informative figure 22.

**NOTE:** The D-INFO PDU can be used for other purposes than those defined in the protocol specifications contained in the present document.

### 14.5.1.2.1 Transmission control procedures

Only the transmission control procedures defined in clauses 14.5.1.2.1 c) and d) shall apply in duplex call. In a duplex call the SwMI shall grant permission to talk to both parties in the D-CONNECT and D-CONNECT ACKNOWLEDGE PDUs.



NOTE: for the purposes of clarity, only one instance of `mle_report` is shown.

**Figure 29: Individual call request-to-transmit**

#### a) Request-to-Transmit

The SwMI shall fully control which MS/LS is allowed to transmit. To facilitate this the MS/LS shall request permission to transmit from the SwMI and shall receive a permission to transmit before the MS/LS may begin a circuit mode U-plane transmission. If the SwMI allows, in a "transmission request permission" element, then the MS/LS may request a permission to transmit even if the other party is already transmitting. In this case the SwMI should normally wait for that party to finish the transmission before granting the other user application. Pre-emptive priority requests are dealt with in clause 14.5.1.2.1 f).

If on/off hook signalling is used, the normal mode of operation shall be that the called MS shall be given permission to transmit by setting the transmission grant element accordingly in the D-SETUP PDU. However, if desired, the calling MS can ask for permission to transmit by setting the "request to transmit" bit accordingly in the U-SETUP PDU. This is dealt with in clauses 14.5.1.1.1 and 14.5.1.1.2.

If direct set-up signalling is used, the normal mode of operation shall be that the calling MS shall be given the permission to transmit. However the calling user application may in the U-SETUP PDU allow the called user application to request the permission to transmit first by setting the "request to transmit" bit accordingly in the U-SETUP PDU.

When a user application within a call wants to transmit, a TNCC-TX request shall be sent to the CC via the TNCC-SAP. The CC shall send this request in a U-TX-DEMAND PDU, see figure 29. The TX demand priority should be set to low or high priority, unless this is a pre-emptive request, see clause 14.5.1.2.1 f).

The progress of the transmission of the U-TX DEMAND PDU shall be given locally to the CC in one or more REPORT indication primitives. If the CC receives a REPORT indication with a failed transmission indication as a response to the sending of the U-TX DEMAND PDU the CC shall inform the user application by a TNCC-TX confirm primitive.

If a user application wants to withdraw its request-to-transmit before it has been granted, a TNCC-TX request shall be issued to the TNCC-SAP. The CC shall send this request in a U-TX-CEASED PDU or the previous request should be cancelled locally if still possible. The CC shall send the U-TX CEASED PDU with the stealing permission set to "immediate stealing" and stealing repeats flag set, so that the permission to transmit will be released immediately if allocated.

#### b) Response to Request-to-Transmit

During the call set-up phase. These procedures are dealt with in clauses 14.5.1.1.1 and 14.5.1.1.2. The MS/LS given permission to transmit shall start timer T311.

During a call in progress and when SwMI has decided which MS/LS shall be given permission to transmit, the SwMI shall send a D-TX GRANTED PDU to the granted MS/LS with the transmission grant element set to "transmission granted". The CC sub-entity shall send this information further on to the user application in a TNCC-TX confirm primitive. The other MS/LS involved in the call shall also be informed with a D-TX GRANTED PDU indicating that transmission has been granted to another user. This CC sub-entity shall send this information further on to the user application in a TNCC-TX indication primitive, see figure 29.

If the SwMI rejects the transmission request this shall be indicated to the MS/LS concerned by the "transmission not granted" parameter value in the D-TX GRANTED PDU.

If the SwMI places the transmission request in a queue this shall be indicated to the MS/LS concerned by the "transmission request queued" parameter value in the D-TX-GRANTED PDU. The MS/LS can then assume that the request-to-transmit will be held in the queue until it is either granted by the SwMI or withdrawn by the MS/LS, or the MS/LS receives a D-TX GRANTED PDU containing the "transmission not granted" parameter value.

On reception of a D-TX-GRANTED PDU indicating "transmission granted" or "transmission granted to another user", the CC sub-entity shall issue a CONFIGURE request primitive. The primitive shall carry as a parameter whether the transmit permission has been granted to this MS/LS and a parameter to switch the U-Plane on. The MS/LS given permission to transmit shall start timer T311.

Though the MS shall switch to U-Plane receive if it receives a "transmission granted to another user" response to its transmission request, the MS shall require an explicit response to its transmission request: one of "transmission granted", "transmission not granted" or "transmission queued".

If the CC sends a U-TX-DEMAND PDU whilst the other MS is transmitting, then the SwMI should normally wait for that party to finish the transmission (identified by the receipt of a U-TX-CEASED message) before granting transmission to the other user application. On receipt of the U-TX DEMAND PDU, the SwMI may send a D-TX GRANTED PDU indicating whether the request-to-transmit is queued or rejected. Pre-emptive requests are dealt with under clause 14.5.1.2.1 f).

The SwMI shall not send an unsolicited D-TX GRANTED PDU but it is recognized that a race/error condition may result in the LS/MS receiving one. The CC may choose to follow an unsolicited individually addressed D-TX GRANTED PDU indicating "transmission granted" but if the CC does not want to transmit/send data then it shall use the U-TX CEASED PDU, as it does normally at the end of a speech or data item, to reject the transmission grant.

### c) Permission to Transmit withdrawn

The SwMI may decide to interrupt transmission when resources are required for another call or when the SwMI requires that the call should temporarily pause. In this case the SwMI should send a D-TX-WAIT PDU to each MS/LS (permitting or denying transmission requests according to the "transmission request permission" element). Upon receipt of the D-TX WAIT PDU, the CC sub-entity shall send a TNCC-TX indication to the user application indicating that the transmission is waiting. The CC shall stop timer T311 if activated, enter state WAIT and send a CONFIGURE request to switch the U-Plane off. The MSs shall accept any layer 2 channel assignment and await further instructions on the channel that they have been directed to.

If a request-to-transmit has been queued at the time when the D-TX WAIT PDU is received, the MS shall be allowed to withdraw its request-to-transmit by means of the U-TX-CEASED PDU as described in clause 14.5.1.2.1 e).

If the SwMI sends a D-TX WAIT PDU because it wishes to use an assigned channel for another call, it shall send a layer 2 channel assignment with the D-TX WAIT directing the MS to a signalling channel other than the assigned channel. This is to prevent the change in usage marker associated with re-allocation of the assigned channel to the other call causing the waiting MS to drop the interrupted call.

### d) Permission to Continue with withdrawn call

When the SwMI has decided that the call can continue, the SwMI should send either a D-TX-CONTINUE PDU or a D-TX GRANTED PDU to each MS/LS. When the CC sub-entity receives the notification of the continuation of the call in a D-TX-CONTINUE or D-TX GRANTED PDU it shall return to state CALL-ACTIVE.

The D-TX-CONTINUE PDU shall contain an indication (the continue element) to specify whether the same transmission permission applies as at the time of the interruption. If the continue element is set to "continue", and if the MS/LS was either transmitting or receiving traffic when it received the D-TX WAIT PDU, then the CC sub-entity shall send a CONFIGURE request to switch the U-plane on and to accept the channel change if requested. The MS/LS granted permission to transmit shall start timer T311. If the continue element is set to "not continue", or if the MS/LS was neither transmitting nor receiving traffic when it received the D-TX WAIT PDU, then the U-plane shall not be switched on and the MS/LS shall assume that any previous transmission permission no longer applies.

If the D-TX-CONTINUE PDU contains an indication that the MS/LS is allowed to request transmission permission, it may follow the transmission control procedures described in clause 14.5.1.2.1 a).

There are three cases as follows:

- 1) if no MS/LS was granted transmission at the time when the SwMI sent the D-TX WAIT PDU, or if an MS/LS was granted transmission at the time of the D-TX WAIT PDU but the SwMI does not wish that transmission to continue, then either a D-TX-CONTINUE PDU with the continue element set to "not continue" or D-TX GRANTED with transmission grant element set to "not granted" shall be sent individually to both MS/LSs in the call. The CC shall accept any layer 2 channel allocation. All CC sub-entities shall return to state CALL-ACTIVE but the U-plane shall not be switched on and the MS/LS shall assume that any previous transmission permission no longer applies. If the D-TX CONTINUE PDU or D-TX GRANTED PDU contains an indication that the MS/LS is allowed to request transmission permission, it may follow the transmission control procedures described in clause 14.5.1.2.1 a).

- 2) If there was at least one MS/LS granted transmission at the time when the SwMI sent the D-TX-WAIT PDU, and if the SwMI wishes the transmission to continue, then either a D-TX-CONTINUE PDU with the Continue element set to "continue" or D-TX GRANTED with transmission grant element set to "transmission granted" or "transmission granted to another" shall be sent individually to both MS/LSs and the CC shall accept any layer 2 channel allocation. If a D-TX-CONTINUE PDU with the Continue element set to "continue" is sent, it shall give the earlier granted MS/LS permission to continue transmission. The MS granted permission to transmit shall start timer T311. All CC sub-entities shall return to state CALL ACTIVE and shall send a CONFIGURE request to the lower layers to switch the U-plane on.
- 3) If there was one MS/LS granted transmission at the time when the SwMI sent the D-TX-WAIT PDU but the SwMI wishes to give the transmission permission to the other party or if no MS/LS was granted transmission at the time when the SwMI sent the D-TX WAIT PDU and the SwMI wishes to give the transmission permission now to another party, the SwMI may first send a D-TX-CONTINUE with the Continue element set to "not continue" individually to both MS/LSs. A D-TX GRANTED shall then be sent as an individual message to the granted MS/LS with information element transmission grant set to "transmission granted" and with information element transmission grant set to "transmission granted to another user" to not-granted MS/LS (if any). When receiving either D-TX CONTINUE or D-TX GRANTED PDU the CC sub-entity shall return to state CALL-ACTIVE. In addition when receiving D-TX GRANTED PDU CC shall send a CONFIGURE request to the lower layers to switch the U-plane on.

If the MS/LS is in state WAIT and it receives a D-TX GRANTED PDU then it shall obey the instruction in the D-TX GRANTED PDU.

#### e) End of Transmission

At the end of a transmission, the user application shall send a TNCC-TX request to the TNCC-SAP indicating ceased transmission. The CC sub-entity shall send this information in a U-TX-CEASED PDU, remain in state CALL-ACTIVE and stop timer T311. The CC shall send the U-TX CEASED PDU with the stealing permission set to "immediate stealing" and the stealing repeats flag set. Upon receipt of the U-TX-CEASED PDU, the SwMI may send a D-TX-CEASED PDU to each MS/LS informing them that the transmission has now ceased.

Upon reception of a D-TX-CEASED PDU, the CC shall send this information further on to the user application in a TNCC-TX indication (transmission ceased). The CC sub-entity shall send a CONFIGURE request to the lower layers to switch the U-Plane off.

Also, if the CC that is sending the U-TX CEASED PDU receives a REPORT indication of either successful or unsuccessful transmission of that PDU by the lower layers, then it shall behave as if it had received a D-TX CEASED PDU i.e. it shall send a TNCC-TX indication (transmission ceased) to the user application and shall send a CONFIGURE request to the lower layers to switch the U-Plane off.

If there was a request for transmission already queued in the SwMI when the U-TX-CEASED PDU was received, then the SwMI should send a D-TX GRANTED PDU to each MS/LS as described in clause 14.5.1.2.1 b), without sending an explicit D-TX-CEASED PDU. The CC sub-entity shall send a CONFIGURE request to the lower layers to indicate the change in the transmit permission.

NOTE: The End of Transmission procedure is not valid for a duplex call.

The SwMI shall not send an unsolicited D-TX CEASED PDU but it is recognized that a race/error condition may result in the LS/MS receiving one. If CC receives an unsolicited D-TX CEASED PDU it shall send this information further on to the user application in a TNCC-TX indication (transmission ceased) and shall send a CONFIGURE request to the lower layers to switch the U-Plane off.

#### f) Stop Transmission order

If, during the course of a transmission, a MS/LS wishes to interrupt the transmitting MS/LS, it shall send a U-TX-DEMAND PDU indicating the wanted level of pre-emptive priority in the TX demand priority element. If the SwMI supports transmission interruption, it shall then send a D-TX-INTERRUPT PDU to the MS that currently has the permission to transmit. Upon reception of a D-TX-INTERRUPT PDU, the CC shall stop transmission and remain in state CALL-ACTIVE, stop timer T311, send a TNCC-TX indication primitive to the user application indicating transmission interrupt and send a CONFIGURE request to lower layers to indicate the loss of transmit permission. The SwMI should then send a D-TX-GRANTED PDU to the requesting MS/LS indicating that the permission to transmit has been awarded as described in clause 14.5.1.2.1 b).



The D-TX-INTERRUPT PDU shall indicate that transmission is granted to another user and then the MS/LS shall switch to U-plane reception. Otherwise, if there is a delay before the pre-emptive priority transmission, the SwMI may indicate "transmission not granted" in the D-TX-INTERRUPT PDU. Then the MS/LS shall switch the U-plane off and wait for a D-TX-GRANTED PDU.

g) Expiry of timer T311; call transmission timer

Upon expiry of timer T311, CC shall remain in state ACTIVE, send a TNCC-TX indication primitive to the user application and a U-TX-CEASED PDU to the peer entity. The CC shall send the U-TX-CEASED PDU with the stealing permission set to "immediate stealing" and stealing repeats flag set.

#### 14.5.1.2.2 Call status information procedures

The D-INFO PDU can be used for carrying call status messages from SwMI to the MS/LS. When a D-INFO PDU is received, depending on the notification, the following actions are taken by CC:

a) Call in queue

When the SwMI has put a call into a queue it may send a D-INFO PDU. If the D-INFO PDU contains a value for the call time-out, set-up phase, the CC shall start timer T301 or T302, as appropriate, using the specified value. The CC shall send the information to the application in a TNCC-NOTIFY indication primitive. If the call is queued at call set-up time the D-INFO PDU should be preceded by a D-CALL PROCEEDING PDU.

b) Call is proceeding

This may be sent to the calling user application during the call set-up phase to indicate e.g. that the call set-up time through a gateway will be longer than for a normal call set-up time. The information that the timer value shall be changed is made available to the CC sub-entity in the D-INFO PDU. The CC shall start T302 with the indicated timer value. The CC shall send the information further on to the application in a TNCC-NOTIFY indication primitive.

c) SwMI is paging called user

When the SwMI is paging a called user, e.g. when the called user is on another network, the SwMI may send a D-INFO PDU with the call status parameter indicating this situation. If the D-INFO PDU contains a value for the call time-out, call set-up phase element, the CC shall start timer T302 using the specified value.

d) Prolonging the call time-out time

The SwMI may decide to change the call time-out time by sending a D-INFO PDU with a new T310 value. Upon reception of the D-INFO PDU containing the "call time-out" element, T310 shall be started using the defined value. If the SwMI supplies a T310 value in the D-INFO PDU, it shall set the value of the "reset call time-out timer" element of the PDU to indicate reset of T310.

The SwMI may also choose to reset the call time-out time and start it again using the current defined value. Upon reception of the D-INFO PDU with the "reset call time-out timer" element indicating that T310 shall be reset, T310 shall be started using the value defined earlier.

In either case, the Timer value shall be sent further on to the application in a TNCC-NOTIFY indication primitive.

The SwMI may also change the call timeout time during call restoration by supplying the "call time-out" element in the D-CALL RESTORE PDU, refer to clause 14.5.1.2.4. If the SwMI supplies a T310 value in the D-CALL RESTORE PDU, it shall set the value of the "reset call time-out timer" element of the PDU to indicate reset of T310.

NOTE: This procedure is applicable both in semi-duplex and full-duplex calls.

### 14.5.1.2.3 Call modification procedures

The MS/LS service user may modify the service of an existing call. To initiate a modification the user application shall issue a TNCC-MODIFY request primitive and the CC sub-entity shall send a U-INFO PDU and wait for a D-INFO PDU from the SwMI before changing any of the current service parameters. The SwMI should not send D-INFO to modify a service while an ongoing U-plane transmission is in progress.

When a service has been changed by the SwMI, e.g. when a point-to-point call has been changed to a point-to-multipoint call, the SwMI should indicate this to the calling and called parties by sending a D-INFO PDU. Upon reception of a D-INFO PDU the CC sub-entity shall send it to the application in a TNCC-MODIFY indication primitive. Finally the CC shall send a CONFIGURE request primitive for lower layer configuration.

If the SwMI is unable to provide the requested service, it should either send a D-INFO PDU to the requesting party containing the current service (unchanged), or send a D-INFO PDU to the calling and called parties containing an alternative service. For example, if a user application requests an increase from a 1-slot per frame call to a 4-slots per frame call, and the SwMI is unable to allocate more than 2 slots to the call, it may offer a 2-slots per frame call in the D-INFO PDUs.

If the call has changed from point-to-point to point-to-multipoint, a temporary group address and a group call reference number (call identifier) shall be given. The new group call reference number can be the current call identifier of the including party.

The service may be changed between any combination of one or more of the following:

- duplex operation may be changed to simplex operation; or
- simplex operation may be changed to duplex operation;
- a point-to-point call may be changed to a point-to-multipoint call;
- a clear call may be changed to an encrypted call; or
- an encrypted call may be changed to a clear call;
- a 4-slots per frame call may be changed to a 1-slot, 2-slot or 3-slot call;
- a 3-slot call may be changed to a 1-slot, 2-slot or 4-slot call;
- a 2-slot call may be changed to a 1-slot, 3-slot or 4-slot call;
- a 1-slot call may be changed to a 2-slot, 3-slot or 4-slot call;
- a circuit mode type (TCH/S, TCH/7.2, TCH/4.8 or TCH/2.4) may be changed to a different circuit mode type (with the requested interleaving depth in the case of TCH/4.8 or TCH/2.4);
- a protected circuit mode data type (TCH/4.8 or TCH/2.4) may be changed to a different interleaving depth from the set of permissible values ( $N = 1, 4$  or  $8$ ).

NOTE: The clear and encrypted calls refer to the end-to-end clear and encrypted calls. The end-to-end encryption control is independent of the air interface encryption control.

It is also possible to change between the circuit mode speech teleservices.

The encryption state of each transmission, defined using D-TX GRANTED, can be set independently by the encryption control element in the U-TX-DEMAND PDU. The SwMI should not change the requested encryption state in the responding D-TX-GRANTED PDU from that requested in the U-TX-DEMAND PDU.

If the MS/LS cannot support a new service combination, indicated by D-INFO, D-TX GRANTED or D-TX INTERRUPT, the user application or the CC, as appropriate, shall disconnect the call (see clause 14.5.1.3.1). The U-DISCONNECT PDU shall contain disconnection cause "requested service not available" or in case of incompatible encryption control, the disconnect cause shall be "Called party does not support encryption" or "Called party requires encryption".

## 14.5.1.2.4 Call restoration procedures

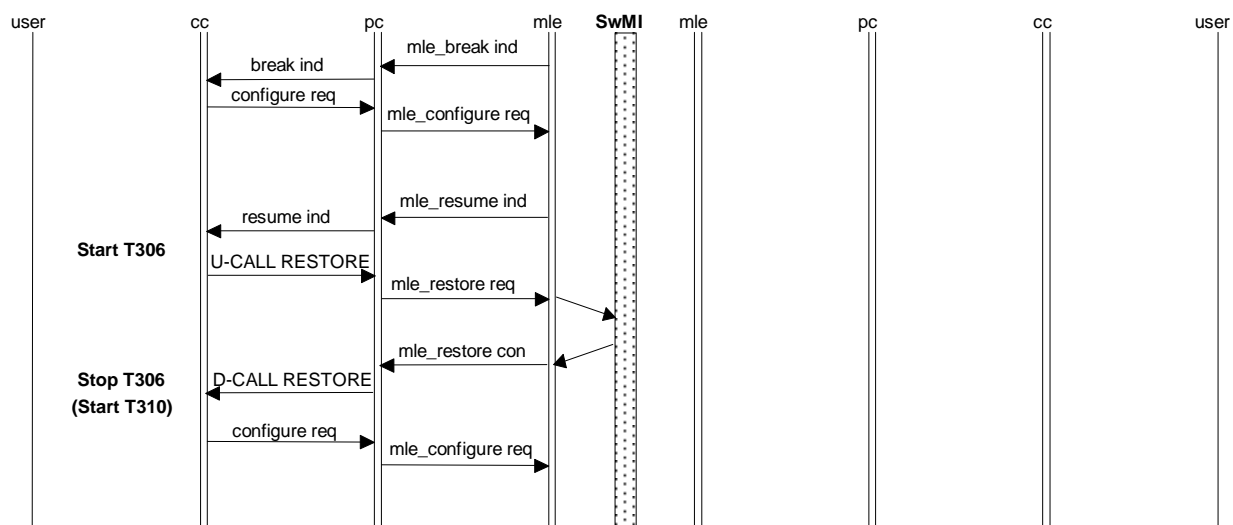


Figure 30: Individual call - successful call restoration

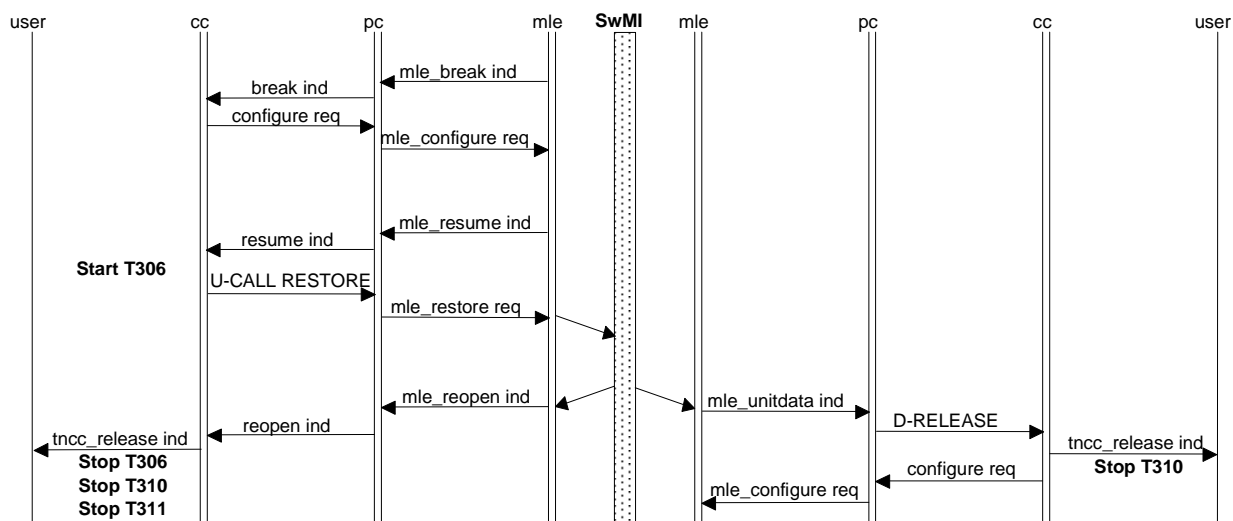


Figure 31: Individual call - unsuccessful call restoration

The responsibility of the procedure shall be to restore the call when the temporary break condition has been resolved by lower layers.

When the CC receives a BREAK indication, then the CC sub-entity shall try to restore the call as described in this clause:

- when the CC receives a BREAK indication, the CC shall send a CONFIGURE request to switch the U-plane off as described in clause 14.5.1.4 and remain in state CALL-ACTIVE. If the CC had permission to transmit/send data at that time the CC shall assume that the permission is now ended as if the CC had sent a U-TX CEASED PDU or SwMI had withdrawn permission to talk. If the MS is in state WAIT when it receives a BREAK indication then it shall behave as if it had received a D-TX CONTINUE PDU with the continue element set to "not continue". It shall then obey the instructions in the D-CALL RESTORE PDU;

- if the CC receives a RESUME indication indicating that the C-plane may now be used again, it shall issue a U-CALL RESTORE PDU in a RESTORE request primitive containing the SSI, TSI or SNA of the other party in the individual call and the call identifier of the call which CC wants to restore. If the other party address is not available, then the dummy address (all zeroes) shall be used. If the CC wishes to continue transmission in the new cell, or keep a queued transmission request valid in the new cell, it shall indicate so in the request to transmit/send data information element in the U-CALL RESTORE PDU. A MS which has requested for transmit permission on a previous cell and has received a "transmission request queued" response or no response at all on that cell, may either refresh the transmission request by requesting for transmit permission in the U-CALL RESTORE on the new cell, or withdraw the transmission request by requesting for receive permission in the U-CALL RESTORE on the new cell. A MS which attempts call restoration having received a "transmission request queued" indication on a previous cell can assume that its transmission request is still held in the SwMI's queue unless the MS receives a "transmission not granted" indication within the call restoration signalling. After sending a U-CALL RESTORE PDU, CC shall start timer T306 and wait for a D-CALL-RESTORE PDU;
- when the CC receives a D-CALL-RESTORE PDU in a RESTORE indication primitive, timer T306 shall be stopped, and the call shall be resumed with the new parameters, see figure 30. The CC shall obey the transmission granting in the transmission grant information element for both semi-duplex and full-duplex calls, refer to clause 14.5.1.2.1. Timer T310 shall be reset and started only if the "Reset call timeout" information element value is 1 (Reset call time-out timer T310); the T310 value shall be taken from the D-CALL RESTORE PDU call timeout information element and, if not present in the PDU, from the previous value (provided in D-CONNECT, D-CONNECT ACKNOWLEDGE or D-INFO). If appropriate the CC shall issue a CONFIGURE request using the procedure in clause 14.5.1.4;
- if a MS restores to a cell without requesting for transmit permission and receives a D-CALL RESTORE with "Call status" element having value "Call is queued" (indicating that the cell has no available traffic resources), the value of the "Transmission grant" element in the D-CALL RESTORE shall be "Transmission not granted". If the call subsequently proceeds to traffic (it may be cleared while queued), the MS shall expect to receive one of the following PDUs; the MS shall then expect no further signalling for the call restoration:
  - simplex call: D-TX GRANTED, containing a layer 2 channel allocation, with "Transmission grant" element having value "Transmission granted to another user". The MS shall switch the U-plane on; the MS is authorized to receive traffic;
  - simplex call: D-TX GRANTED, containing a layer 2 channel allocation, with "Transmission grant" element having value "Transmission not granted". The MS shall retain its current U-plane state (and shall perform the channel change);
  - duplex call: not applicable - the MS shall request for permission to transmit when restoring to a duplex call;
- if a MS restores to a cell, requests for transmit permission, and receives a D-CALL RESTORE with "Call status" element having value "Call is queued" (indicating that the cell has no available traffic resources), the value of the "Transmission grant" element in the D-CALL RESTORE shall be either "Transmission request queued" (MS shall wait for further signalling to indicate the result of its request to transmit) or "Transmission not granted" (MS's request to transmit is rejected - this is not a valid response for a duplex call; MS behaviour if it receives such a response is outside the scope of the present document). If the call subsequently proceeds to traffic (it may be cleared while queued), the MS shall expect to receive one of the following PDUs:
  - simplex call: D-TX GRANTED, containing a layer 2 channel allocation, with "Transmission grant" element having value "Transmission granted to another user". The MS shall switch the U-plane on; the MS is authorized to receive traffic; the MS shall, if its request to transmit was not rejected by the "Call is queued" D-CALL RESTORE, wait for further signalling to indicate the result of its request to transmit;
  - simplex call: D-TX GRANTED, containing a layer 2 channel allocation, with "Transmission grant" element having value "Transmission not granted". The MS shall retain its current U-plane state (and shall perform the channel change); the MS's request to transmit, if still outstanding following receipt of the "Call is queued" D-CALL RESTORE, is rejected;

- simplex call: D-TX GRANTED, containing a layer 2 channel allocation, with "Transmission grant" element having value "Transmission request queued". The MS shall not switch the U-plane on (but shall perform the channel change); the MS shall wait for further signalling to indicate the result of its request to transmit. The SwMI shall not use this value of the "Transmission grant" element if the "Call is queued" D-CALL RESTORE rejected the MS's request to transmit; MS behaviour if it receives such a response in this context is outside the scope of the present document;
- simplex call: D-TX GRANTED, containing a layer 2 channel allocation, with "Transmission grant" element having value "Transmission granted". The MS shall switch the U-plane on; the MS is authorized to transmit. The SwMI shall not use this value of the "Transmission grant" element if the "Call is queued" D-CALL RESTORE rejected the MS's request to transmit; MS behaviour if it receives such a response is described in clause 14.5.1.2.1 b) (refer to text describing handling of unsolicited transmission grant);
- duplex call: D-TX GRANTED, containing a channel allocation, with "Transmission grant" element having value "Transmission granted". The MS shall switch the U-plane on; the MS is authorized to transmit and receive.

On expiry of Timer T306, the procedure defined in clause 14.5.1.3.4 shall apply.

The call length timer T310 shall continue running during the call restoration and on expiry of T310, the procedure defined in clause 14.5.1.3.4 shall apply.

If the call cannot be resumed the CC should receive a REOPEN indication primitive indicating that the call is lost. The CC shall then stop Timer T306 and return to state IDLE, and it shall send a TNCC-RELEASE indication to the user application with the cause of disconnection, see figure 31.

If the SwMI provides a new call identifier with the D-CALL RESTORE PDU, CC shall use it in all subsequent signalling relating to that call. After a cell change, the MS shall not send any other call related signalling than U-CALL RESTORE until it has received a D-CALL RESTORE PDU (and possible new call identifier) from the SwMI.

A MS which is queueing for a traffic channel during restoration and which has an outstanding transmission request, may cancel that transmission request by sending a U-TX CEASED PDU. A MS which is queueing for a traffic channel during restoration and which does not have an outstanding transmission request, may make a transmission request by sending a U-TX DEMAND PDU, providing the SwMI has not disallowed transmission requests (via the "transmission request permission" element).

If there is more than one circuit mode call active at the time when the MLE-BREAK indication was received, each call shall be restored separately and hence U-CALL RESTORE and D-CALL RESTORE PDUs shall be exchanged one by one for each call.

#### 14.5.1.2.5 DTMF procedures

When a user application requires to transfer DTMF digits to another user application during a circuit mode call, it shall issue a TNCC-DTMF request primitive (DTMF tone delimiter = "DTMF tone start") to the CC entity, followed by a TNCC-DTMF request primitive (DTMF tone delimiter = "DTMF tone end") to the CC entity. The duration of time between the "start" and "end" primitives, and the number of digits contained in the start primitive, shall be application-dependent, though normally generation of the start primitive will correspond with a DTMF key press, generation of the end primitive will correspond with the release of that key and the start primitive will contain the digit corresponding to the key press.

CC shall generate U-INFO PDUs corresponding to the TNCC-DTMF request primitives (see clauses 14.8.19, 14.8.19a and 14.8.19b), the only restriction being that CC shall not send a "DTMF tone end" U-INFO PDU if layer 2 has not indicated successful transmission of the preceding "DTMF tone start" U-INFO PDU.

On the reception of a D-INFO "DTMF tone start" PDU the CC shall forward the DTMF digits contained in the PDU to the user application in a "start" TNCC-DTMF indication. On the reception of a D-INFO "DTMF tone end" PDU the CC shall send an "end" TNCC-DTMF indication to the user application. If CC receives two identical "start" PDUs (i.e. containing the same DTMF digits) without an intervening "end" PDU it shall ignore the second "start" PDU. If CC receives two "end" PDUs without an intervening "start" PDU it shall ignore the second "end" PDU. If CC receives two different "start" PDUs without an intervening "end" PDU it shall forward the digits contained in both PDUs to the user application.

A SwMI may choose to filter repeated "start" and "end" DTMF U-INFO PDUs in the manner described in the previous clause before forwarding DTMF digits to a MS/LS (in a D-INFO PDU) or gateway (see below).

A receiving MS/LS or gateway which does not support or subscribe to DTMF signalling may respond to a DTMF D-INFO PDU with a U-INFO PDU, the DTMF type element (refer clause 14.8.19b) having value "DTMF not supported" or "DTMF not subscribed". The SwMI should forward this response to the addressed MS/LS (i.e. the MS/LS which initiated the DTMF signalling) in a D-INFO PDU.

A receiving SwMI which does not support or subscribe to DTMF signalling may respond to a DTMF U-INFO PDU with a D-INFO PDU, the DTMF type element (refer clause 14.8.19b) having value "DTMF not supported" or "DTMF not subscribed".

On the reception of a D-INFO "DTMF not supported" or "DTMF not subscribed" PDU (refer clause 14.8.19b), CC shall forward the failure to the user application in a TNCC-DTMF indication containing a "DTMF result" parameter specifying the nature of the failure (refer clause 11.3.3.3). Note that a user application should receive such an indication only after having generated DTMF digits itself. It is outside the scope of the present document how the user application should handle the rejection of DTMF signalling.

The U-INFO PDU may be routed to a gateway. In this case, the receiving user application can be for example, either an external network subscriber application or an exchange of the external network that uses two stage dialling to set-up calls in the external network. The gateway shall convert the DTMF digits into dual tone multi-frequency signals towards the external network. The gateway shall support the filtering of repeated "start" and "end" DTMF U-INFO PDUs described above.

A receiving entity (i.e. MS/LS or gateway) shall start generation of one or more DTMF tones at the first reception of a "start" PDU. The receiving entity shall ignore any repeated "start" PDUs. It is outside the scope of the present document how DTMF tones are generated if the receiving entity receives two or more different "start" PDUs without an intervening "end" PDU.

The "end" PDU shall stop the generation of tone or tones after the minimum period of tone/no-tone sequence or sequences as defined for the application e.g. PSTN gateway. When the reception of the "end" PDU is delayed longer than the minimum tone period of the single or last digit in the "start" PDU the tone generating application may continue to generate tone for a predefined time; the generation time is outside the scope of the present document. The receiving entity shall ignore any repeated "end" PDUs.

The next "start" PDU after an "end" PDU shall start generation of the DTMF tone only after a valid no-tone period as defined for the application.

The minimum length of tone generated by the tone generating application, e.g. a gateway, should be suitable for potential applications in analog telecommunication networks.

NOTE 1: The DTMF signalling can be used only after either a D-CONNECT or D-CONNECT ACK PDU has been received and the TETRA call is established.

NOTE 2: DTMF signalling may not function correctly during a circuit mode data call (a data modem signal will seriously disturb and be disturbed by DTMF signalling). The support of DTMF signalling during data calls is outside the scope of the present document.

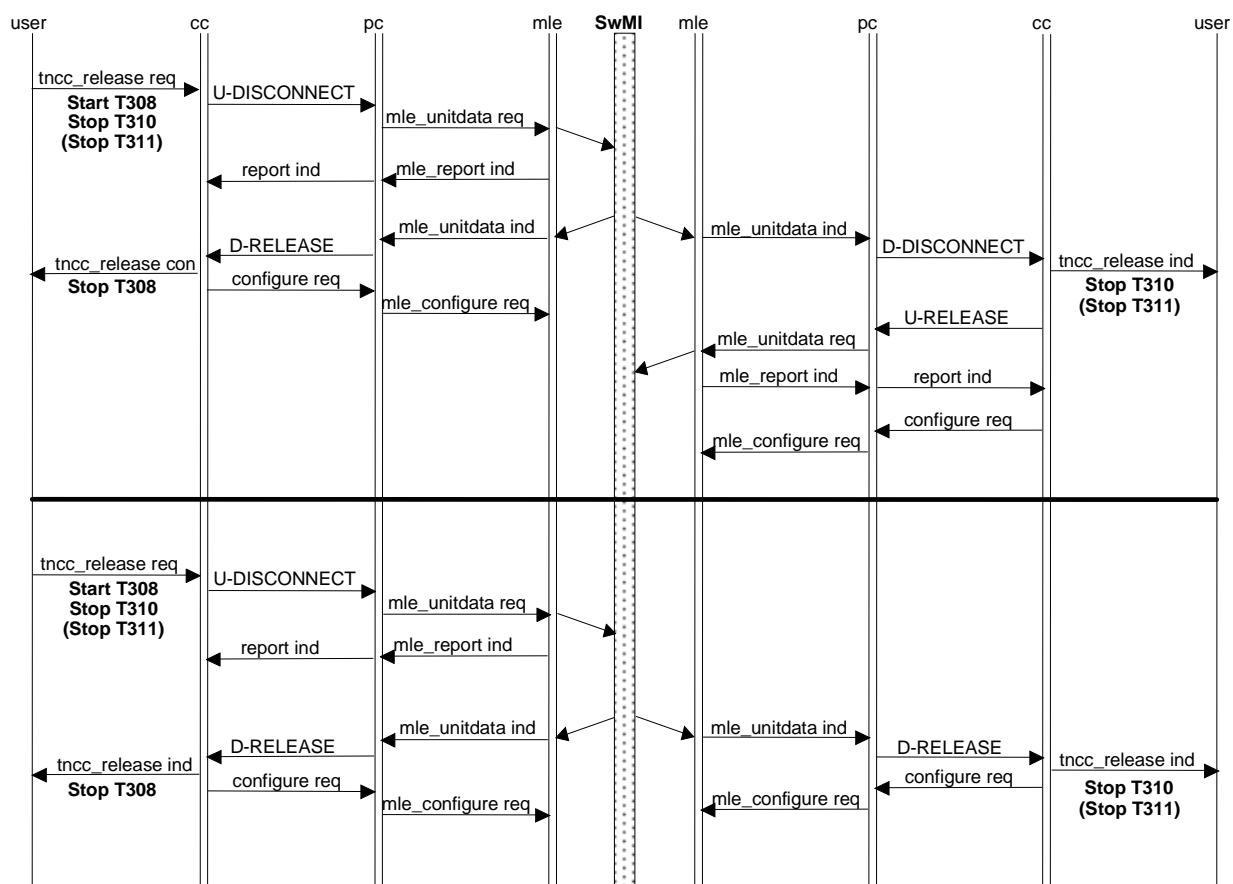
#### 14.5.1.2.6 Calls to and from external subscribers

An MS/LS can make a call to a subscriber in an external network using a gateway. The call set-up message shall address the gateway using a particular SSI as the called party address and the U-SETUP PDU shall contain the external network subscriber number in the corresponding element. The gateway shall then set-up the call to the external network subscriber using that number without further call set-up messages from the calling MS/LS.

NOTE 1: The particular SSI address or addresses which identify the gateway or gateways are not defined by this part of the present document.

NOTE 2: Calls from external network subscribers to TETRA subscribers are supported in the air interface including presentation of the external user number, if available. This part of the present document does not describe gateway functions, which are independent of the air interface protocol.

### 14.5.1.3 Call disconnection procedures



NOTE: For the purposes of clarity, only 1 instance of mle\_report has been shown.

**Figure 32: Individual call request-to-disconnect**

#### 14.5.1.3.1 User initiated disconnection

Either the calling or called user application may initiate a call disconnection at any state of a call. This shall be done by sending a TNCC-RELEASE request to the CC sub-entity.

- During call set-up phase until the U-SETUP PDU has been transmitted to the SwMI, a disconnection can be handled locally using a CANCEL request. Information regarding the local progress of the transmission of a PDU is received in REPORT indications. After a local cancellation the CC sub-entity shall stop timer T303 and return to state IDLE.
- On receipt of a TNCC-RELEASE request the CC sub-entity shall enter state CALL-DISCONNECT, send a U-DISCONNECT PDU, start timer T308 and stop all other T3xx timers. The progress of the disconnection PDU sending shall be reported back to CC with REPORT indications.
- Should the user application disconnect the call during the window between transmission of a U-SETUP and reception of a D-CALL PROCEEDING, D-ALERT or D-CONNECT (i.e. before the MS/LS has received a call identifier for the call), it shall use the dummy call identifier (all zeroes).

- After sending a U-DISCONNECT PDU the CC shall wait for a D-RELEASE PDU. When a D-RELEASE PDU or a REPORT indication with reason PDU transfer failed is received, or timer T308 expires, the CC sub-entity shall clear the call identifier and shall return to state IDLE, issuing a TNCC-RELEASE confirm to the user application, see figure 32. The CC sub-entity shall send a CONFIGURE request to the lower layers to switch the U-Plane off, reject any pending channel change response request for that call (refer to clause 14.5.3.2), and leave the assigned channel (if the MS is on an assigned channel when the CONFIGURE request is sent). If a channel change response is required for the D-RELEASE PDU, CC shall accept that channel change (refer to clause 14.5.3.2).

The SwMI should inform the other MS in the call of the call clearance either by a D-DISCONNECT PDU or by a D-RELEASE PDU, see clause 14.5.1.3.3.

#### 14.5.1.3.2 Network initiated disconnection

In the case where the SwMI cannot support a request for a call from the calling MS/LS, the SwMI should send a D-RELEASE PDU, containing the reason for disconnection, to the calling MS/LS.

In the case where the SwMI can no longer support an established call, it should send D-RELEASE PDUs to the calling and called MS/LSs containing the reason for disconnection, and should subsequently release the call.

Refer to clause 14.5.1.3.3 for the MS/LS actions.

#### 14.5.1.3.3 Reception of disconnection request

The BS may send a disconnection request at any phase of the call and the MS/LS shall react as follows:

- when the CC sub-entity receives a D-DISCONNECT PDU the CC shall respond by sending a U-RELEASE PDU;
- when the CC sub-entity receives a D-RELEASE PDU the CC shall not send any response;
- in both cases the CC shall inform the user application with a TNCC-RELEASE indication, clear the call identifier, stop all T3xx timers and enter state IDLE, see figure 32. The CC sub-entity shall send a CONFIGURE request informing the lower layers to switch the U-Plane off, reject any pending channel change response request for that call (refer to clause 14.5.3.2), and leave the assigned channel (if the MS is on an assigned channel when the CONFIGURE request is sent). If a channel change response is required for the D-RELEASE PDU or D-DISCONNECT PDU, CC shall accept that channel change (refer to clause 14.5.3.2).

#### 14.5.1.3.4 Expiry of timers

##### a) Timer T301; call set-up timer for called MS/LS

Upon expiry of timer T301, CC shall send a TNCC-RELEASE indication primitive to the user application, send a U-DISCONNECT PDU and follow the procedures in clause 14.5.1.3.1. The value of the disconnect cause element shall be set to "expiry of timer".

##### b) Timer T302; call set-up timer for calling MS/LS

Upon expiry of timer T302, CC shall send a TNCC-RELEASE indication primitive to the user application, send a U-DISCONNECT PDU and follow the procedures in clause 14.5.1.3.1. The value of the disconnect cause element shall be set to "expiry of timer".

##### c) Timer T303; call initiated timer for calling MS/LS

Upon expiry of timer T303, CC shall send a TNCC-RELEASE indication primitive to the user application, send a U-DISCONNECT PDU and follow the procedures in clause 14.5.1.3.1. The value of the Disconnect Cause element shall be set to "expiry of timer".

##### d) Timer T306; call restoration timer for point-to-point calls

Upon expiry of timer T306, CC shall return to state IDLE, and send a TNCC-RELEASE indication primitive to the user application. The value of the disconnect cause element shall be set to "expiry of timer".



e) Timer T308; call disconnect timer

Upon expiry of timer T308, CC shall return to state IDLE, send a TNCC-RELEASE confirm primitive to the user application and shall send a CANCEL request to the lower layers to cancel the sending of the U-DISCONNECT PDU. The CC sub-entity shall send a CONFIGURE request to the lower layer to switch the U-Plane off, reject any pending channel change response request for that call (refer to clause 14.5.3.2), and leave the assigned channel (if the MS is on an assigned channel when the CONFIGURE request is sent).

f) Timer T310; call length timer

Upon expiry of timer T310, CC shall send a TNCC-RELEASE indication primitive to the user application, send a U-DISCONNECT PDU and follow the procedures in clause 14.5.1.3.1. The value of the disconnect cause element shall be set to "expiry of timer".

g) Timer T311; call transmission timer

Refer to 14.5.1.2.1 g).

#### 14.5.1.3.5 Colliding disconnection

Disconnection collision can occur when both sides simultaneously send DISCONNECT PDUs specifying the same call identifier value. If a CC sub-entity receives a D-DISCONNECT PDU when CC has just issued a U-DISCONNECT PDU, the CC sub-entity shall discard the outgoing disconnection request and respond to the incoming D-DISCONNECT PDU as defined in clause 14.5.1.3.3.

If the U-DISCONNECT PDU collides with a D-RELEASE PDU, the CC sub-entity shall release the call immediately as defined in clause 14.5.1.3.3.

In either case the CC shall send a CANCEL request to the lower layers to cancel the sending of the U-DISCONNECT PDU.

#### 14.5.1.4 U-Plane switching

The U-Plane switching procedure ensures that traffic/signalling synchronization between CMCE and MAC is maintained during the lifetime of a call. The CC informs the MAC when it has permission to transmit traffic (i.e. TCH or STCH) and when to stop. The CC also informs the MAC when it may process received traffic (and when to stop). The latter procedure also assists the MAC to interpret when the received bit-stream on the assigned channel is TCH/STCH and when it is SCH.

The CC changes the U-plane operation in the MAC by issuing the CONFIGURE request primitive, indicating "Switch U-plane = On" or "Switch U-plane = Off", "Tx grant = true" or "Tx grant = false" and "simplex/duplex = simplex" or "simplex/duplex = duplex". There shall be only four valid combinations:

- 1) Switch U-plane = On, Tx grant = true, simplex/duplex = simplex:
  - MS/LS is authorized to transmit traffic.
- 2) Switch U-plane = On, Tx grant = false, simplex/duplex = simplex:
  - MS/LS is authorized to receive traffic.
- 3) Switch U-plane = On, Tx grant = true, simplex/duplex = duplex:
  - MS/LS is authorized to transmit and receive traffic.
- 4) Switch U-plane = Off:
  - withdraws previous authorization to transmit and/or receive traffic.

#### 14.5.1.4.1 End of call set-up phase

When the CC in a MO call receives a D-CONNECT PDU, or when the CC in a MT call receives a D-CONNECT ACKNOWLEDGE PDU, it shall issue a CONFIGURE request primitive to the lower layers containing information about the call e.g. the type of traffic, the interleaving depth, the call identifier and whether the call is end-to-end encrypted.

If the transmission grant element in the PDU is set to "transmission granted" then the CONFIGURE request shall contain the parameter value "Switch U-Plane = On" and "Tx grant = true" to indicate that the MAC has permission to transmit traffic. If the transmission grant element is set to "transmission granted to another user" then the CONFIGURE request shall contain the parameter value "Switch U-Plane = On" but shall contain "Tx grant = false" to indicate that the MAC should receive traffic.

For the other values of the transmission grant element, the U-plane shall not be switched on.

#### 14.5.1.4.2 During call maintenance phase

##### a) Transmission grant control

When the CC receives a D-TX-GRANTED PDU, and if the transmission grant element is set to "transmission granted" or "transmission granted to another user", then the CC shall issue a CONFIGURE request containing the parameter value "Switch U-Plane = On" and indicating whether the MAC has permission to transmit traffic ("Tx grant = true" or "Tx grant = false" respectively). For the other values of the transmission grant element, the U-plane state shall not be changed.

NOTE: Sometimes consecutive CONFIGURE requests issued to the lower layers will both contain the instruction to "Switch U-plane On" but will change the traffic transmit permission.

##### b) Transmission ceased

When CC receives a D-TX-CEASED PDU, or on receipt of a REPORT indication of either successful or unsuccessful transmission of a U-TX CEASED PDU, the CC shall issue a CONFIGURE request containing the parameter value "Switch U-Plane = Off".

##### c) Temporary pause

When the CC receives a D-TX WAIT PDU, and if the U-plane is currently switched on for either transmission or reception, the CC shall issue a CONFIGURE request containing the parameter value "Switch U-plane = Off".

When the CC receives a D-TX CONTINUE PDU, and if the Continue element is set to "continue" and the U-plane was switched on at the time of receipt of the D-TX WAIT PDU, then the CC shall issue a CONFIGURE request containing the same parameter values as before the temporary interruption. Otherwise, the U-plane shall not be switched on.

##### d) Interruption

When the CC receives a D-TX INTERRUPT PDU, and if the transmission grant element is set to "transmission granted to another user", the CC shall issue a CONFIGURE request containing the parameter value "Switch U-Plane = On" but shall contain "Tx grant = false" to indicate that the MAC should receive traffic (and no longer has permission to transmit traffic). For the other values of the transmission grant element, the CC shall issue a CONFIGURE request containing the parameter value "Switch U-Plane = Off".

##### e) Call restoration

When CC receives a BREAK indication indicating that a temporary break in the radio link has occurred, the CC shall issue a CONFIGURE request containing the parameter value "Switch U-Plane = Off".

When CC receives a D-CALL-RESTORE PDU indicating that the call has now been restored after a temporary break in the radio link, and if the transmission grant element is set to "transmission granted" or "transmission granted to another user", then the CC shall issue a CONFIGURE request containing the parameter value "Switch U-Plane = On" and indicating whether the MS has permission to transmit traffic ("Tx grant = true" or "Tx grant = false" respectively). For the other values of the transmission grant element, the U-plane shall not be switched on.

### 14.5.1.4.3 Call disconnection phase

When CC receives a D-RELEASE PDU or a D-DISCONNECT PDU, or on receipt of a REPORT indication of either successful or unsuccessful transmission of a U-DISCONNECT PDU, the CC shall issue a CONFIGURE request to the lower layers containing the parameter value "Switch U-Plane = Off".

## 14.5.2 Group CC procedures

The CC procedures handled by CC shall be applicable for circuit mode calls for both speech and data. The circuit mode speech and data group calls shall be set-up as point-to-multipoint calls. The specification below shall be applicable for the procedures that reside in the MS/LS.

### 14.5.2.1 Call set-up procedures

#### a) Normal group call

The normal group call procedures provide support for one type of call set-up, where the MS is placed immediately into the call upon receipt of the D-SETUP PDU if the called user application can support the call and with immediate action being taken by the called user application.

The set-up signalling procedures shall allow immediate communication to take place between the calling and called user applications without the possibility of having an alerting process and without an explicit response from the called user application stating that the user has answered. The call priority may affect whether the user application accepts the call or not.

NOTE: The behaviour of the user application between the reception of the incoming set-up signalling and the acceptance/reject of the call is outside the scope of the present document.

The MS does not signal that acceptance or rejection to the BS.

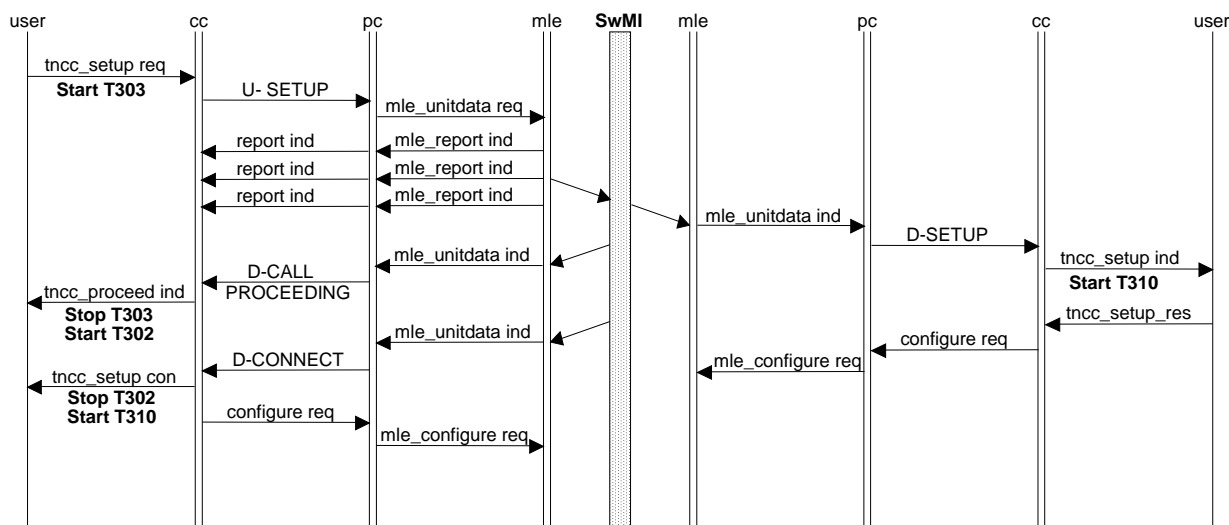
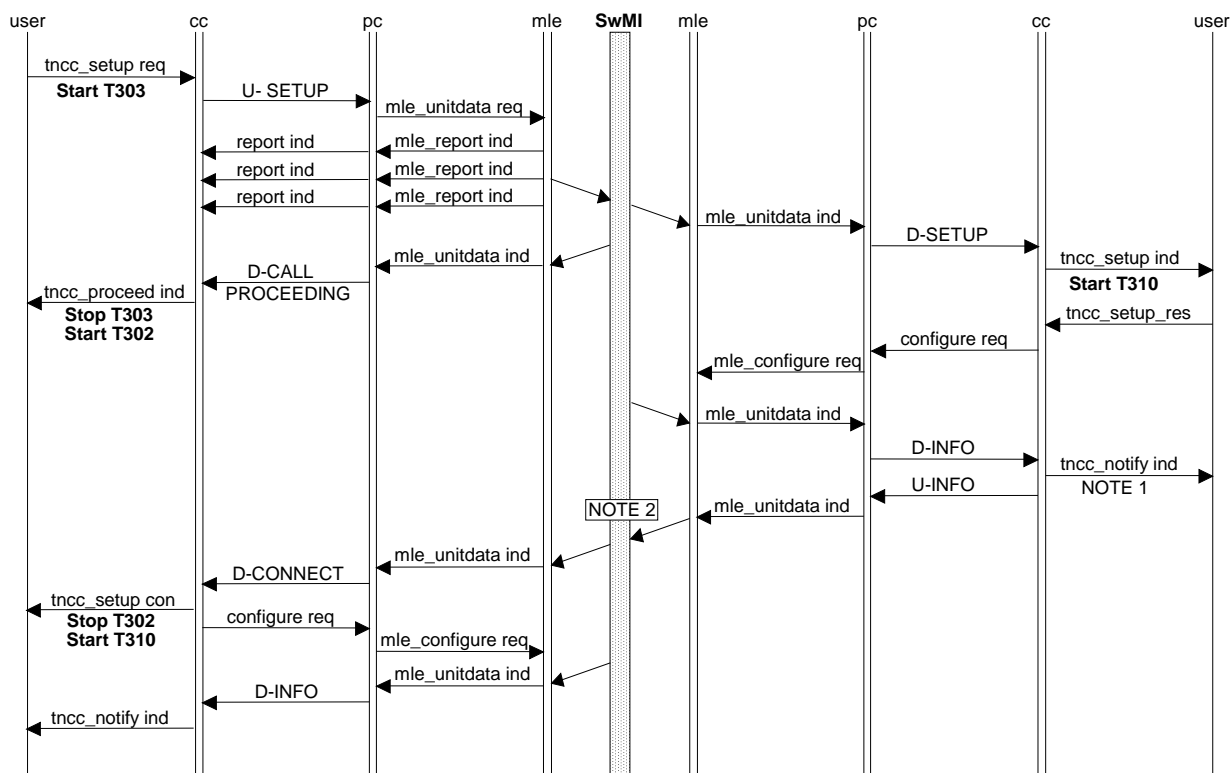


Figure 33: Group call - set-up phase

## b) Acknowledged group call

An acknowledged group call allows the SwMI to poll members of the called group during the call. The call may be through connected to the calling MS either before polling or after polling has taken place (see clause 14.5.2.6).



NOTE 1: The Poll request may also be presented to the user for information only.

NOTE 2: As an option, the call may not be allowed to proceed until certain criteria have been met.

**Figure 34: Acknowledged group call - set-up phase**

## c) Broadcast call

The call set-up procedure for broadcast call shall be the same as that for group call as shown in figure 33. However, in this case the called MSs shall not be allowed to subsequently request transmit permission.

## 14.5.2.1.1 Incoming call

Notification of the arrival of an incoming call to the CC sub-entity shall be made by the reception of a D-SETUP PDU which shall be delivered to the user application in a TNCC-SETUP indication via the TNCC-SAP. The CC shall enter state MT-CALL-SETUP. If the user application can support the call, it shall immediately return a TNCC-SETUP response.

On reception of a TNCC-SETUP response the CC sub-entity shall enter state CALL ACTIVE and take the following actions, which are dependent upon the information contained within the PDU elements, see figure 33, right hand side:

- the call identifier shall be used as the reference to this call in subsequent PDUs for the duration of the call;
- when CC receives TNCC-SETUP response indicating that the called user application has accepted the incoming call, the CC sub-entity shall enter state CALL ACTIVE and start timer T310. The D-SETUP PDU shall contain an indication in the transmission grant element whether the MS/LS should switch to U-plane reception. If the D-SETUP PDU contains an indication that the MS/LS is allowed to request transmission permission it may follow the transmission control procedures described in clause 14.5.2.2.1 a). The CC sub-entity shall send a CONFIGURE request for lower layer configuration accepting the channel change;

- where the called user application is unable to accept the request for a certain target service, the call shall be rejected locally by issuing a TNCC-RELEASE request via the TNCC-SAP and the CC shall enter state IDLE. No negotiation with the BS shall be possible. The CC sub-entity shall send a CONFIGURE request for lower layer configuration rejecting the channel change.

#### 14.5.2.1.2 Outgoing call

A user application initiates call establishment by transferring a TNCC-SETUP request across the TNCC-SAP to the CC sub-entity. The TNCC-SETUP request shall be handled by a CC sub-entity that is in state IDLE. The CC shall select a PDU priority based on the requested access priority value as defined in clause 14.5.6.2. The CC shall convert this request into a U-SETUP PDU and send it. The CC sub-entity shall then enter the MO-CALL-SETUP state and start timer T303, see figure 33 - left hand side.

The following text describes the normal call set-up procedures:

- to indicate the progress of the transmission of the U-SETUP PDU the CC may receive one or more REPORT indications. If the CC receives a REPORT indication informing that the PDU transmission has failed, timer T303 shall be stopped, and the CC sub-entity shall inform the user application with a TNCC-RELEASE indication and return to state IDLE;
- the SwMI may respond to the reception of the U-SETUP PDU with a D-CALL PROCEEDING PDU. Upon reception of the D-CALL-PROCEEDING PDU, the CC shall inform the user application by issuing a TNCC-PROCEED indication, stop timer T303, and start timer T302;
- the D-CALL-PROCEEDING PDU shall contain a call identifier which shall be used as the reference to this call in subsequent PDUs for the duration of the call;
- the D-INFO PDU shall not be used to allocate a call identifier;
- on reception of a D-INFO PDU after reception of D-CALL PROCEEDING but before the call set-up is completed, the CC shall start timer T302 from the value indicated in the call time out, set-up phase element if that element is present;
- if the call through connection is ready at the time when the D-CALL PROCEEDING PDU should have been sent, a D-CONNECT PDU should be sent instead. In this instance the D-CONNECT PDU shall allocate the call identifier;
- on receipt of a D-CONNECT PDU, the CC shall enter state CALL ACTIVE, and inform the user application with a TNCC-SETUP confirm, and stop timer T302 or T303 and start timer T310. The D-CONNECT PDU shall contain an indication as to whether the CC has been given permission to transmit. If transmission is not granted and the D-CONNECT PDU contains an indication that the MS/LS is allowed to request transmission permission it may follow the transmission control procedures defined in clause 14.5.2.2.1. The CC sub-entity shall send a CONFIGURE request for lower layer configuration accepting the channel change. If the CC has been given permission to transmit then it shall start timer T311;
- where the D-CONNECT or D-CALL PROCEEDING PDU indicates that the offered service is different to the one requested, and if the service offered is acceptable to the CC sub-entity according to the selected lowest service in the TNCC-SETUP request primitive, then the call shall continue. If it is not acceptable, then the CC shall disconnect the call using the procedures in clause 14.5.2.3.1;
- the network may support other signalling from the calling MS to the SwMI and vice versa during the call set-up phase using U-INFO and D-INFO PDUs, for example, for the purpose of showing the progress of a call set-up.

- on reception of a group addressed D-SETUP after reception of D-CALL PROCEEDING (and optionally D-INFO), if the call identifier in the D-SETUP is the same as the call identifier in the D-CALL PROCEEDING and the calling party address in the D-SETUP does not contain the LS/MS's own address, the CC sub-entity shall enter state CALL ACTIVE, stop timer T302 and start timer T310. The D-SETUP PDU shall contain an indication in the transmission grant element whether the MS/LS should switch to U-plane reception. If the D-SETUP PDU contains an indication that the MS/LS is allowed to request transmission permission it may follow the transmission control procedures described in clause 14.5.2.2.1 a). The CC sub-entity shall send a CONFIGURE request for lower layer configuration accepting the channel change. CC shall ignore the D-SETUP if the calling party address is the same as the LS/MS's own address and shall send a CONFIGURE request for lower layer configuration ignoring the channel change. A MS/LS following a group addressed D-SETUP in the manner described in this clause shall cancel its request to transmit if it requested to transmit in the U-SETUP.

NOTE 1: The SwMI should either send the D-CONNECT granting transmit permission first or supply the calling party address in the D-SETUP (or both) to prevent the MS/LS that is about to be granted transmit permission following the group addressed D-SETUP.

NOTE 2: Handling of the TNCC-SETUP request primitive may be affected by the MS being active in a MM procedure, this being indicated to CC from MLE via the MLE-BUSY indication primitive, refer to clause 18.3.5.4. The exact nature of the interaction between MM/MLE and CC is outside the scope of this part of the present document but it is recommended that CC not accept a TNCC-SETUP request while MM is busy.

#### 14.5.2.1.3 Colliding calls

Call collisions can occur when both the SwMI and the MS/LS simultaneously send a D-SETUP PDU and a U-SETUP PDU. Two call set-ups are colliding when a D-SETUP PDU is received within the window where the CC waits for a call identifier from the SwMI after a U-SETUP PDU has been issued. The MS/LS shall be able to handle two types of call collision:

- if the colliding calls are call set-up attempts for the same group and the requested basic services are compatible and the calling MS/LS is a member of that group and layer 2 has not indicated successful transmission of the U-SETUP PDU, then the MS CC shall attempt to discard the outgoing call set-up attempt by sending a CANCEL request to the lower layers to cancel sending of the U-SETUP PDU. If cancellation is successful, the MS shall accept the incoming call. If cancellation is unsuccessful or if layer 2 has indicated successful transmission of the U-SETUP PDU, the MS shall continue its own call set-up and wait for a D-CALL PROCEEDING and/or D-CONNECT PDU (and/or D-RELEASE PDU);
- if the call set-up attempts are not to the same group, then the MS shall either keep its call attempt or accept the incoming call as defined in clause 14.5.2.1.1. In the latter case the MS shall first cancel its call set-up locally, if still possible, or otherwise send a U-DISCONNECT PDU for its own call set-up, refer clause 14.5.2.3.1. If MAC requested a response with the parameter channel change response required value set to "true" with the CC message the CC shall select the proper radio resource by issuing MLE-CONFIGURE request primitive with value "reject" in the first case or "accept" in the latter case. Refer to clause 14.5.3.2.

#### 14.5.2.1.4 Unsuccessful call set-up

Unsuccessful call set-up shall refer specifically to those instances where a circuit mode connection was not successfully established. It shall not refer to call disconnection or call rejection. If a PDU is not responded to prior to the expiry of the corresponding timer, the procedure in clause 14.5.2.3.5 shall apply. All timers available are listed in clause 14.6.

When CC receives a REPORT indication indicating that the lower layers have not been successful (failed transfer) in the sending of any of the call set-up PDUs, then the CC sub-entity shall return to state IDLE and inform the user application with a TNCC-RELEASE indication accompanied with a cause of the disconnection.

#### 14.5.2.1.5 Call rejection

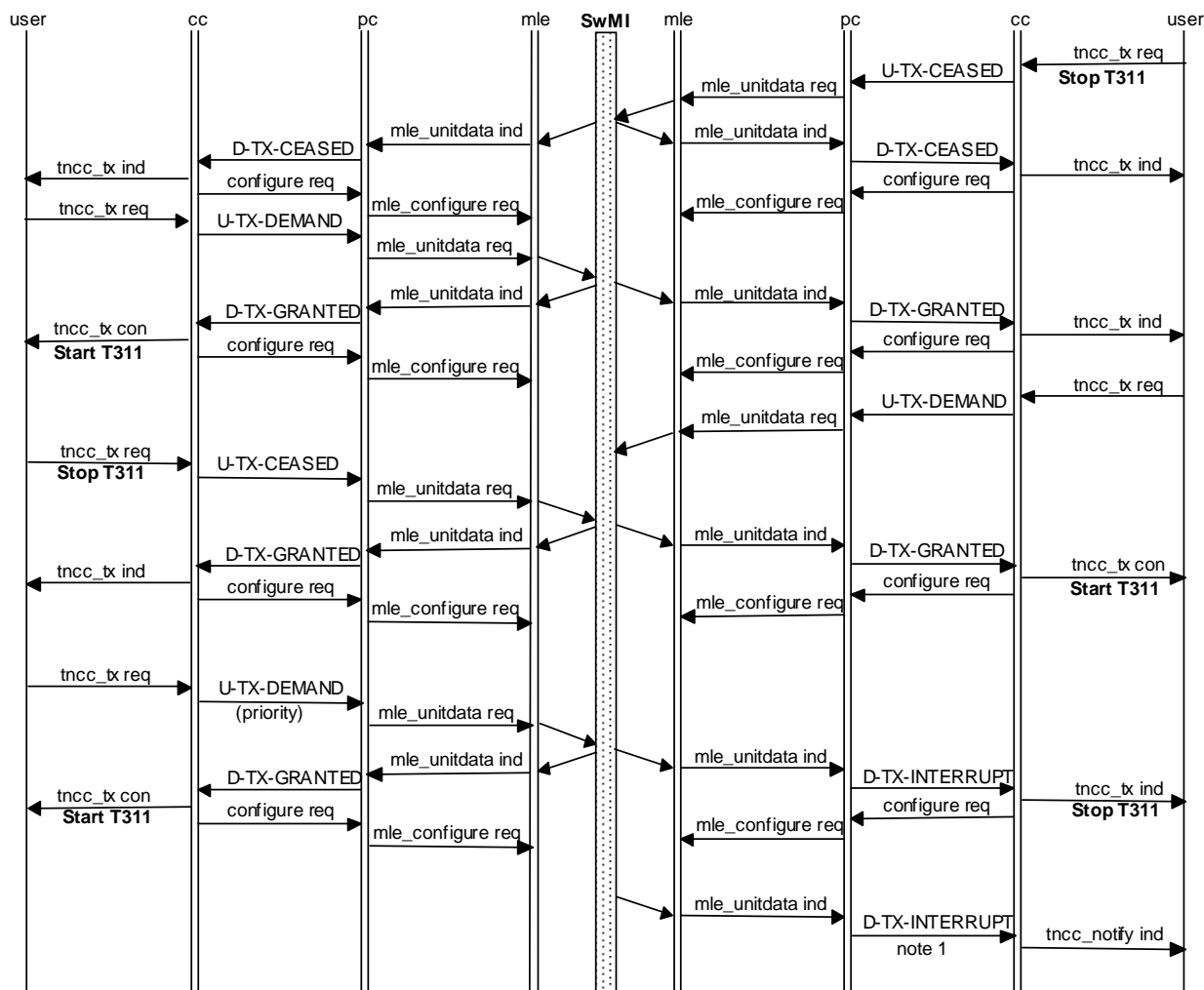
If the user application decides to reject the incoming call set-up request as defined in clause 14.5.2.1.1, it shall immediately transfer a TNCC-RELEASE request to the CC sub-entity. This request shall locally clear the call identifier. The CC sub-entity shall then change to state IDLE.

### 14.5.2.2 Call maintenance procedures

The call maintenance procedures described in this clause may be applied when the MS/LS is in states MO-CALL SETUP, MT-CALL SETUP or CALL-ACTIVE. The main state CALL-ACTIVE can comprise several sub-states.

NOTE: The D-INFO PDU can be used for other purposes than those defined in the protocol specifications contained in the present document.

#### 14.5.2.2.1 Transmission control procedures



NOTE 1: D-TX INTERRUPT is sent to the remaining members of the group upon permission award to the MS shown on the left hand side of this figure.

NOTE 2: For the purposes of clarity, instances of mle\_report are not shown.

**Figure 35: Group call - request-to-transmit**

#### a) Request-to-transmit

The SwMI shall fully control which MS/LS is allowed to transmit. To facilitate this, the MS/LS shall request permission to transmit, and permission shall be granted before the MS can begin circuit mode traffic permission. MS/LSs may request permission to transmit, if the SwMI allows it by a "transmission request permission" element even if another party is transmitting. In this case the SwMI should normally wait for that party to finish the transmission before granting the other user application. Pre-emptive priority requests are dealt with in clause 14.5.2.2.1 f).

The SwMI normally gives the first permission to transmit to the calling MS/LS when a new call has been set-up. However, the calling user application may allow the called users to request permission to transmit first. The calling CC shall in that case set the "request to transmit" bit accordingly in the U-SETUP PDU.

When a user within a call wants to transmit, a TNCC-TX request shall be sent to CC via the TNCC-SAP. The CC shall send this request in a U-TX-DEMAND PDU. The TX-DEMAND Priority level should be set to low or high priority, unless this is a pre-emptive priority request, see clause 14.5.2.2.1 f), see figure 35.

The progress of the transmission of the U-TX DEMAND PDU shall be given locally to the CC in one or more REPORT indication primitives. If the CC receives a REPORT indication as a response to the sending of the U-TX DEMAND PDU informing that the PDU transmission has failed, the CC shall inform the user application by a TNCC-TX confirm primitive.

If a user application wants to withdraw his request-to-transmit before it has been granted, a TNCC-TX request shall be sent from the user application to the TNCC-SAP. The CC shall send this request in a U-TX-CEASED PDU. The CC shall send the U-TX CEASED PDU with the stealing permission set to "immediate stealing" and stealing repeats flag set so that the permission to transmit will be released immediately if allocated. No CC protocol response shall be received from the SwMI for this message.

#### b) Response to request-to-transmit

During a call in progress and when the SwMI has decided which MS/LS shall be given permission to transmit, the SwMI shall send a D-TX GRANTED PDU as an individual message to the granted MS/LS. Upon reception of a D-TX GRANTED PDU indicating "transmission granted", the CC sub-entity shall send this information to the user application in a TNCC-TX confirm. The other MS/LSs involved in the call shall be informed with a D-TX GRANTED PDU addressed with the group address. That D-TX-GRANTED PDU shall indicate that permission to transmit has been granted to another user. The CC shall send this information to the user application in a TNCC-TX indication and shall remain in state CALL-ACTIVE, see figure 35.

If the SwMI places the transmission request in a queue this shall be indicated to the MS/LS concerned using the "transmission request queued" parameter value in the D-TX-GRANTED PDU. If the SwMI rejects the transmission request this may be indicated to the MS/LS concerned using the "transmission not granted" parameter value in the D-TX GRANTED PDU. In either case, the MS/LSs concerned shall remain in state CALL-ACTIVE.

Upon reception of a D-TX-GRANTED PDU indicating "transmission granted" or "transmission granted to another user", the CC sub-entity shall issue a CONFIGURE request primitive. The primitive shall carry as a parameter whether the transmit permission has been granted to this CC sub-entity or to another CC sub-entity, and to switch the U-Plane on. The MS/LS given permission to transmit shall start timer T311. If the D-TX GRANTED PDU indicates "transmission granted to another user" and contains the LS/MS's own address as the transmitting party address then that MS/LS should not switch to U-plane reception. However it shall not switch to U-plane transmission until it receives a D-TX GRANTED PDU indicating "transmission granted".

Though the MS shall switch to U-Plane receive if it receives a "transmission granted to another user" response to its transmission request and the transmitting party address in the D-TX GRANTED PDU is not the LS/MS's own address, the LS/MS shall require an explicit response to its transmission request: one of "transmission granted", "transmission not granted" or "transmission queued".

NOTE 1: The SwMI should either send the individually addressed D-TX GRANTED ("transmission granted") first or supply the transmitting party address in the group addressed D-TX GRANTED ("transmission granted to another user") to prevent the LS/MS that is about to be granted transmit permission switching to U-plane receive. As defined in ETS 300 396-5 [14], clause 9, this is mandatory for the SwMI when granting transmit permission to a Direct Mode MS which is operating through a Direct Mode gateway. (This mandatory requirement applies only if the SwMI has accepted a request from the gateway to operate as a Direct Mode gateway.)

Upon reception of a D-TX GRANTED PDU indicating "transmission granted to another user", and if the CC sub-entity has issued a U-TX DEMAND PDU to the lower layers and has not yet received a REPORT indication indicating successful or unsuccessful transmission, then the CC sub-entity shall send a CANCEL request primitive to the lower layers to cancel transmission (and retransmissions) of that PDU.

NOTE 2: The above procedure may sometimes stop retransmissions by the awarded MS/LS as well as retransmissions by any other MS/LSs that are requesting transmit permission.



NOTE 3: If the SwMI queues any other transmission requests that it received then it should, at a convenient time, send D-TX GRANTED PDUs containing the "transmit request queued" parameter value to the MS/LSs concerned. For transmission requests that are neither granted nor queued, and if the user application still wishes to transmit, then it has to send another TNCC-TX request to the CC.

After reception of a D-TX GRANTED PDU indicating "transmission granted", and while it still has permission to transmit, the CC shall ignore any group addressed D-TX GRANTED or D-TX INTERRUPT PDUs it may receive (and any layer 2 channel assignment received with those PDUs by issuing an MLE-CONFIGURE request ignoring the channel change, if requested).

If the CC sends a U-TX-DEMAND PDU whilst another MS is transmitting, the SwMI should normally wait for that party to finish the transmission (identified by the receipt of a U-TX-CEASED PDU), before granting transmission permission to the other user application. On receipt of the U-TX DEMAND PDU, the SwMI may send a D-TX GRANTED PDU indicating whether the request-to-transmit is queued or rejected. Pre-emptive priority requests are dealt with in clause 14.5.2.2.1 f).

The SwMI shall not send an unsolicited D-TX GRANTED PDU but it is recognized that a race/error condition may result in the LS/MS receiving one. The CC may choose to follow an unsolicited individually addressed D-TX GRANTED PDU indicating "transmission granted" but if the CC does not want to transmit/send data then it shall use the U-TX CEASED PDU, as it does normally at the end of a speech or data item, to reject the transmission grant.

#### c) Permission to transmit withdrawn

The SwMI may decide to interrupt transmission when resources are required for another call or when the SwMI requires that the call should temporarily pause. In this case the SwMI should send a D-TX-WAIT PDU to all MS/LSs in that call (permitting or denying transmission requests according to the "transmission request permission" element). On reception of the D-TX-WAIT PDU the CC sub-entity shall send a TNCC-TX indication to the user application indicating that the transmission is waiting. The CC shall stop timer T311, if activated, enter state WAIT, and send a CONFIGURE to switch the U-Plane off. The CC shall accept any layer 2 channel allocation and await further instructions on the channel that they have been directed to.

If a request-to-transmit has been queued at the time when the D-TX WAIT PDU is received, the MS shall be allowed to withdraw its request-to-transmit by means of the U-TX-CEASED PDU as described in clause 14.5.2.2.1 e).

A group-addressed D-TX WAIT PDU shall apply to all the MS/LSs in the call (including the transmitting MS/LS). Optionally, the D-TX WAIT PDU may also be sent individually addressed to the transmitting MS/LS enabling the SwMI to obtain a layer 2 acknowledgement from that MS/LS.

If the SwMI sends a D-TX WAIT PDU because it wishes to use an assigned channel for another call, it shall send a layer 2 channel allocation with the D-TX WAIT directing the MS to a signalling channel other than the assigned channel. This is to prevent the change in usage marker associated with re-allocation of the assigned channel to the other call causing the waiting MS to drop the interrupted call.

#### d) Permission to continue with withdrawn call

There are three cases as follows:

- 1) If no MS/LS was granted transmission at the time when the SwMI sent the D-TX WAIT PDU, or if an MS/LS was granted transmission at the time of the D-TX WAIT PDU but the SwMI does not wish that transmission to continue, then either a D-TX-CONTINUE PDU with the continue element set to "not continue", or a D-TX GRANTED PDU with the transmission grant element set to "transmission not granted", shall be sent as a group message to all MS/LSs in the group. The CC shall accept any layer 2 channel allocation. All CC sub-entities shall return to state CALL-ACTIVE but the U-plane shall not be switched on and the MS/LS shall assume that any previous transmission permission no longer applies. If the D-TX CONTINUE PDU contains an indication that the MS/LS is allowed to request transmission permission, it may follow the transmission control procedures described in clause 14.5.2.2.1 a).

- 2) If there was one MS/LS granted transmission at the time when the SwMI sent the D-TX-WAIT PDU, and if the SwMI wishes that transmission to continue, then either a D-TX-CONTINUE PDU with the Continue element set to "continue" shall be sent as a group message to the group, or a D-TX GRANTED PDU with the transmission grant element set to "transmission granted" shall be sent to the granted MS/LS and a D-TX GRANTED PDU with the transmission grant element set to "transmission granted to another" shall be sent as a group message to the group. The CC shall accept any layer 2 channel allocation. If a D-TX-CONTINUE PDU with the Continue element set to "continue" is sent, it shall give the earlier granted MS/LS permission to continue transmission. The MS granted permission to transmit shall start timer T311. All CC sub-entities shall return to state CALL ACTIVE and shall send a CONFIGURE request to the lower layers to switch the U-plane on.

A group-addressed D-TX CONTINUE PDU shall apply to all the MS/LSs in the call (including the awarded MS/LS). Optionally, the D-TX CONTINUE PDU may also be sent individually addressed to the awarded MS/LS enabling the SwMI to obtain a layer 2 acknowledgement from that MS/LS.

- 3) If there was one MS/LS granted transmission at the time when the SwMI sent the D-TX-WAIT PDU but the SwMI wishes to give the transmission permission to the other party or if no MS/LS was granted transmission at the time when the SwMI sent the D-TX WAIT PDU and the SwMI wishes to give the transmission permission now to one party, the SwMI may first send a D-TX-CONTINUE. If a MS/LS has requested permission to transmit during the period when the transmission was withdrawn, the SwMI should first send a D-TX-CONTINUE as a group message with the Continue element set to "not continue". A D-TX GRANTED should then be sent as an individual message to the granted MS/LS with information element transmission grant set to "transmission granted" and as a group message to the rest of the group with information element transmission grant set to "transmission granted to another user". When receiving either D-TX CONTINUE or D-TX GRANTED PDU the CC sub-entity shall return to state CALL-ACTIVE. In addition when receiving D-TX GRANTED PDU CC shall send a CONFIGURE request to the lower layers to switch the U-plane on.

If the MS/LS is in state WAIT and it receives a D-TX GRANTED PDU, it shall return to state CALL-ACTIVE and obey the instruction in the D-TX GRANTED PDU.

#### e) End of Transmission

At the end of a transmission the user application shall send a TNCC-TX request to the TNCC-SAP indicating ceased transmission. The CC sub-entity shall send this information in a U-TX-CEASED PDU and stop timer T311. The CC shall send the U-TX CEASED PDU with the stealing permission set to "immediate stealing" and the stealing repeats flag set. Upon reception of the U-TX-CEASED PDU, the SwMI normally sends a D-TX-CEASED PDU to the group informing the group members that the transmission has now ceased.

Upon reception of a D-TX-CEASED PDU the CC shall send this information to the user application in a TNCC-TX indication (transmission ceased) and the CC shall send a CONFIGURE request to the lower layers to switch the U-Plane off, see figure 35.

Also, if the CC that is sending the U-TX CEASED PDU receives a REPORT indication of either successful or unsuccessful transmission of that PDU by the lower layers, then it shall behave as if it had received a D-TX CEASED PDU i.e. it shall send a TNCC-TX indication (transmission ceased) to the user application and shall send a CONFIGURE request to the lower layers to switch the U-Plane off. If a D-TX CEASED PDU is received but no REPORT indication of successful transmission of the U-TX CEASED PDU then the CC shall send a CANCEL request primitive to the lower layers to stop retransmissions of the U-TX CEASED PDU.

NOTE 4: The requirement for the CC to cancel retransmissions may apply if the SwMI sends only a group-addressed D-TX CEASED PDU and the transmitting MS/LS does not receive a layer 2 acknowledgement.

If there was a request for transmission already queued in the SwMI when the U-TX CEASED PDU was received, the SwMI may send a D-TX GRANTED PDU as an individual message to the granted MS/LS and another D-TX GRANTED PDU as a group message to the rest of the group as described in clause 14.5.2.2.1. b), without sending an explicit D-TX CEASED PDU. However, the SwMI should first send at least a layer 2 acknowledgement to the MS/LS that sent the U-TX CEASED PDU so that the MS/LS can stop its U-plane transmission and start accepting group addressed D-TX GRANTED PDUs.

The SwMI shall not send an unsolicited, individually addressed D-TX CEASED PDU but it is recognized that a race/error condition may result in the LS/MS receiving one. If CC receives an unsolicited, individually addressed D-TX CEASED PDU it shall send this information further on to the user application in a TNCC-TX indication (transmission ceased) and shall send a CONFIGURE request to the lower layers to switch the U-Plane off.

#### f) Stop-transmission order

If a MS/LS wishes to interrupt the transmitting MS with a pre-emptive priority request, it shall send a U-TX-DEMAND indicating the level of priority in the "TX demand priority" element. If the SwMI supports transmission interruption, it shall send a D-TX-INTERRUPT PDU to the MS/LS which currently has permission to transmit. Upon reception of an individually addressed D-TX-INTERRUPT PDU the CC sub-entity shall remain in state CALL-ACTIVE, and shall stop timer T311. The CC shall send information to the user application in a TNCC-TX indication primitive indicating transmission interrupt and the CC sub-entity shall send a CONFIGURE request to the lower layers to switch the U-Plane accordingly (see clause 14.5.2.4).

The SwMI should send a D-TX-INTERRUPT PDU as a group message to the rest of the group indicating that the permission to transmit has been (or will be) allocated to another user, see figure 35. Upon reception of the D-TX-INTERRUPT PDU the CC sub-entity shall remain in state CALL ACTIVE and shall send a TNCC-TX indication primitive to the user application indicating transmission interrupt. The SwMI should then send a D-TX GRANTED PDU as an individual message to the MS/LS that requested the priority transmission.

The D-TX-INTERRUPT PDU shall indicate that transmission is granted to another user and then the MS/LS shall switch to (or remain in) U-plane reception. Otherwise, if there is a delay before the pre-emptive priority transmission, the SwMI may indicate "transmission not granted" in the D-TX-INTERRUPT PDU. Then the MS/LS shall switch the U-plane off and wait for a D-TX-GRANTED PDU.

#### g) Expiry of timer T311: call transmission timer.

Upon expiry of timer T311, CC shall remain in state ACTIVE, shall send a TNCC-TX indication primitive to the user application and a U-TX-CEASED PDU to the peer entity.

### 14.5.2.2.2 Call status information procedures

The D-INFO PDU can be used for carrying call status messages from SwMI to the MS/LS. When a D-INFO PDU is received, depending on the notification, the following actions shall be taken by CC:

- a) call in queue:
  - when the SwMI has put a call into a queue, if the D-INFO PDU contains a value for the call time-out, set-up phase, the CC shall start timer T302 using that value. The CC shall send the information further on to the application in a TNCC-NOTIFY indication primitive. If the call is queued at call set-up time the D-INFO PDU should be preceded by a D-CALL-PROCEEDING PDU;
- b) call is proceeding:
  - this may be sent to the calling user application during the call set-up phase to indicate that the call set-up time will be longer than for a normal call set-up. The information that the call time-out, set-up phase value shall be changed is made available to the CC sub-entity in the D-INFO PDU. The CC shall start T302 using the new timer value. The CC shall send the information further on to the application in a TNCC-NOTIFY indication primitive;
- c) prolonging the call time-out time:
  - the SwMI may decide to change the call time-out time by sending a D-INFO PDU with a new T310 value. Upon reception of the D-INFO PDU containing the "call time-out" element, T310 shall be started using the defined value. If the SwMI supplies a T310 value in the D-INFO PDU, it shall set the value of the "reset call time-out timer" element of the PDU to indicate reset of T310;

- the SwMI may also choose to reset the call time-out time and start it again using the current defined value. Upon reception of the D-INFO PDU with the "reset call time-out timer" element indicating that T310 shall be reset, T310 shall be started using the value defined earlier;
- in either case, the Timer value shall be sent further on to the application in a TNCC-NOTIFY indication primitive;
- the SwMI may also change the call timeout time during call restoration by supplying the "call time-out" element in the D-CALL RESTORE PDU, refer to clause 14.5.2.2.4. If the SwMI supplies a T310 value in the D-CALL RESTORE PDU, it shall set the value of the "reset call time-out timer" element of the PDU to indicate reset of T310.

### 14.5.2.2.3 Call modification procedures

The MS/LS service user may modify the service of an existing call. To initiate a modification the user application shall issue a TNCC-MODIFY request primitive and the CC sub-entity shall send a U-INFO PDU and wait for a D-INFO PDU from the SwMI before changing any of the current service parameters. The SwMI should not send D-INFO to modify a service while an ongoing U-Plane transmission is in progress.

When a service has been changed by the SwMI, the SwMI should indicate this to all parties by issuing the D-INFO PDU. Upon reception of a D-INFO PDU indicating an acceptable service modification the CC sub-entity shall send it to the application in a TNCC-MODIFY indication primitive, and the CC sub-entity shall send a CONFIGURE request primitive for lower layer configuration.

If the SwMI is unable to provide the requested service, it should either send a D-INFO PDU to the requesting party containing the current service (unchanged), or send a D-INFO PDU to all parties containing an alternative service. For example, if a user application requests an increase from a 1-slot per frame call to a 4-slots per frame call, and the SwMI is unable to allocate more than 2 slots to the call, it may offer a 2-slots per frame call in the D-INFO PDUs.

The service may be changed between any combination of one or more of the following:

- a clear call may be changed to an encrypted call; or
- an encrypted call may be changed to a clear call;
- a 4-slots-per-frame call may be changed to a 1-slot, 2-slot or 3-slot call;
- a 3-slot call may be changed to a 1-slot, 2-slot or 4-slot call;
- a 2-slot call may be changed to a 1-slot, 3-slot or 4-slot call;
- a 1-slot call may be changed to a 2-slot, 3-slot or 4-slot call;
- a circuit mode type (TCH/S, TCH/7.2, TCH/4.8 or TCH/2.4) may be changed to a different circuit mode type (with the requested interleaving depth in the case of TCH/4.8 or TCH/2.4);
- a protected circuit mode data type (TCH/4.8 or TCH/2.4) may be changed to a different interleaving depth from the set of permissible values ( $N = 1, 4$  or  $8$ ).

NOTE: The clear and encrypted calls refer to the end-to-end clear and encrypted calls. The end-to-end encryption control is independent of the air interface encryption control.

It is also possible to change between the circuit mode speech teleservice and a circuit mode unprotected (speech, encrypted) bearer service.

The encryption state of each transmission, defined using D-TX GRANTED, can be set independently by the encryption control element in the U-TX-DEMAND PDU. The SwMI should not change the requested encryption state in the responding D-TX-GRANTED PDU from that requested in the U-TX DEMAND PDU.

If the MS/LS cannot support a new service combination indicated by D-INFO, D-TX GRANTED or D-TX-INTERRUPT, the user application or the CC as appropriate shall disconnect or leave the call, refer to clause 14.5.2.3. The U-DISCONNECT PDU shall contain disconnection cause "requested service not available". In case the rejection results from unsupported encryption flag state the disconnect cause shall be "Called party does not support encryption" or "Called party requires encryption".

## 14.5.2.2.4 Call restoration procedures

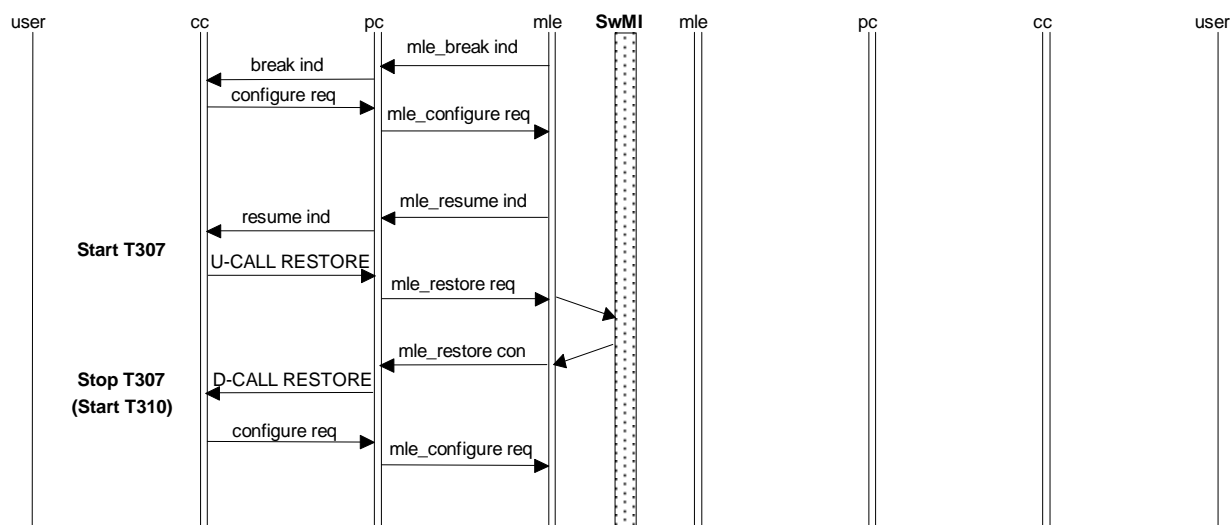


Figure 36: Group call - successful call restoration

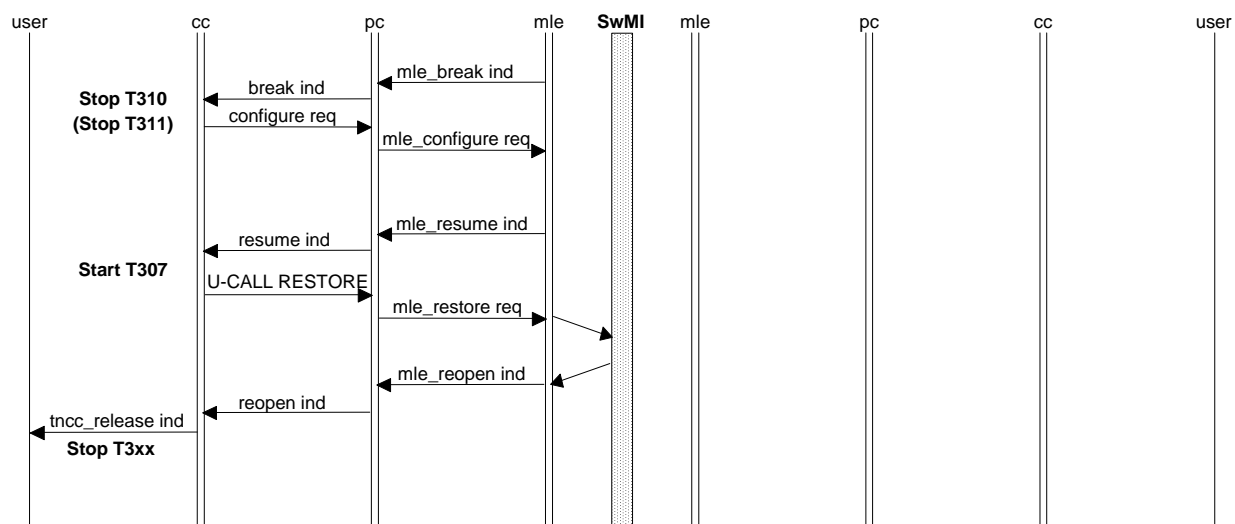


Figure 37: Group call - unsuccessful call restoration

Call restoration of a group call shall only take place in the CC sub-entity when the CC has entered state CALL-ACTIVE. The CC sub-entity should keep information on whether it is active in a group call or an individual call.

When the CC receives a BREAK indication, the CC shall switch the U-Plane off as described in clause 14.5.2.4 and shall remain in state CALL-ACTIVE. If the CC had permission to transmit/send data at that time the CC shall assume that the permission is now ended as if the CC had sent a U-TX CEASED PDU. If the MS is in state WAIT when it receives a BREAK indication then it shall behave as if it had received a D-TX CONTINUE PDU with the continue element set to "not continue". It shall then obey the instructions in the D-CALL RESTORE PDU.

If the CC receives a RESUME indication indicating that the C-Plane may now be used again, it shall issue a U-CALL-RESTORE PDU containing the GSSI or GTSI and the call identifier of the call which CC wants to restore. If a temporary address is used in the call then it shall be used as the GSSI. If the MS is participating in a call within a group that does not belong to current network (e.g. the MS has migrated and the group belongs to its home network) the CC shall use the full GTSI of the group in the U-CALL-RESTORE PDU. If the CC wishes to continue transmission in the new cell, or keep a queued transmission request valid in the new cell, it shall indicate so in the request to transmit/send data information element in the U-CALL RESTORE PDU. A MS which has requested for transmit permission on a previous cell and has received a "transmission request queued" response or no response at all on that cell, may either refresh the transmission request by requesting for transmit permission in the U-CALL RESTORE on the new cell, or withdraw the transmission request by requesting for receive permission in the U-CALL RESTORE on the new cell. A MS which attempts call restoration having received a "transmission request queued" indication on a previous cell can assume that its transmission request is still held in the SwMI's queue unless the MS receives a "transmission not granted" indication within the call restoration signalling. After sending a U-CALL RESTORE PDU, the CC shall start Timer T307 and wait for a D-CALL-RESTORE PDU.

When the CC receives a D-CALL-RESTORE PDU, timer T307 shall be stopped and the call shall be resumed with the new parameters, see figure 36. The CC shall obey the transmission granting in the transmission grant information element, refer to clause 14.5.2.2.1. Timer T310 shall be reset and started only if the "Reset call timeout" information element value is 1 (Reset call time-out timer T310); the T310 value shall be taken from the D-CALL RESTORE PDU call timeout information element and, if not present in the PDU, from the previous value (provided in D-CONNECT, D-CONNECT ACKNOWLEDGE, D-SETUP or D-INFO). If appropriate the CC shall issue a CONFIGURE request to switch the U-Plane on using the procedure in clause 14.5.2.4.

If a MS restores to a cell without requesting for transmit permission and receives an individually addressed D-CALL RESTORE with "Call status" element having value "Call is queued" (indicating that the cell has no available traffic resources), the value of the "Transmission grant" element in the D-CALL RESTORE shall be "Transmission not granted". If the call subsequently proceeds to traffic (it may be cleared while queued), the MS shall expect to receive one of the following PDUs; the MS shall then expect no further signalling for the call restoration:

- group or individually addressed D-TX GRANTED, containing a layer 2 channel allocation, with "Transmission grant" element having value "Transmission granted to another user". The MS shall switch the U-plane on; the MS is authorized to receive traffic;
- group or individually addressed D-TX GRANTED, containing a layer 2 channel allocation, with "Transmission grant" element having value "Transmission not granted". The MS shall retain its current U-plane state (and shall perform the channel change).

If a MS restores to a cell, requests for transmit permission, and receives an individually addressed D-CALL RESTORE with "Call status" element having value "Call is queued" (indicating that the cell has no available traffic resources), the value of the "Transmission grant" element in the D-CALL RESTORE shall be either "Transmission request queued" (MS shall wait for further signalling to indicate the result of its request to transmit) or "Transmission not granted" (MS's request to transmit is rejected). If the call subsequently proceeds to traffic (it may be cleared while queued), the MS shall expect to receive one of the following PDUs:

- group or individually addressed D-TX GRANTED, containing a layer 2 channel allocation, with "Transmission grant" element having value "Transmission granted to another user". The MS shall switch the U-plane on; the MS is authorized to receive traffic; the MS shall, if its request to transmit was not rejected by the "Call is queued" D-CALL RESTORE, wait for further signalling to indicate the result of its request to transmit;
- group or individually addressed D-TX GRANTED, containing a layer 2 channel allocation, with "Transmission grant" element having value "Transmission not granted". The MS shall retain its current U-plane state (and shall perform the channel change); the MS's request to transmit, if still outstanding following receipt of the "Call is queued" D-CALL RESTORE, is rejected;
- individually addressed D-TX GRANTED, containing a layer 2 channel allocation, with "Transmission grant" element having value "Transmission request queued". The MS shall not switch the U-plane on (but shall perform the channel change); the MS shall wait for further signalling to indicate the result of its request to transmit. The SwMI shall not use this value of the "Transmission grant" element if the "Call is queued" D-CALL RESTORE rejected the MS's request to transmit; MS behaviour if it receives such a response in this context is outside the scope of the present document;

- individually addressed D-TX GRANTED, containing a layer 2 channel allocation, with "Transmission grant" element having value "Transmission granted". The MS shall switch the U-plane on; the MS is authorized to transmit. The SwMI shall not use this value of the "Transmission grant" element if the "Call is queued" D-CALL RESTORE rejected the MS's request to transmit; MS behaviour if it receives such a response is described in clause 14.5.2.2.1 b) (refer to text describing handling of unsolicited transmission grant).

The call length timer T310 shall continue running during the call restoration and on expiry of T310, the procedure defined in clause 14.5.2.3.4 shall apply.

If the call cannot be restored the CC shall receive a REOPEN indication primitive indicating that the call is lost.

Upon reception of REOPEN indication or on expiry of timer T307, the CC shall then stop all T3xx timers, clear the call identifier and temporary group address if applicable, and return to state IDLE and it shall send a TNCC-RELEASE indication to the user application with the cause for disconnection, see figure 37.

If the SwMI provides a new call identifier with the D-CALL RESTORE PDU, CC shall use it in all subsequent signalling relating to that call. The MS shall not send any other call related signalling than U-CALL RESTORE, after a cell change, before it has received a D-CALL RESTORE PDU (and possible new call identifier) from the SwMI.

A MS which is queueing for a traffic channel during restoration and which has an outstanding transmission request, may cancel that transmission request by sending a U-TX CEASED PDU. A MS which is queueing for a traffic channel during restoration and which does not have an outstanding transmission request, may make a transmission request by sending a U-TX DEMAND PDU, providing the SwMI has not disallowed transmission requests (via the "transmission request permission" element).

If there is more than one circuit mode call active at the time when the MLE-BREAK indication was received, each call shall be restored separately and hence U-CALL RESTORE and D-CALL RESTORE PDUs shall be exchanged one by one for each call.

#### 14.5.2.2.5 DTMF procedures

When a user application requires to transfer DTMF digits to other user applications during a circuit mode call, it shall issue a TNCC-DTMF request primitive to the CC entity. The DTMF protocol to be used is specified in clause 14.5.1.2.5.

NOTE 1: The DTMF signalling can be used only after either a D-CONNECT or D-SETUP PDU has been received and the TETRA call is established.

NOTE 2: DTMF signalling may not function correctly during a group call (group addressed basic link LLC-acknowledged service is required). The support of DTMF signalling during group calls is outside the scope of the present document.

#### 14.5.2.2.6 Temporary address handling procedures

The SwMI may allocate a temporary group address for a group call in a D-CONNECT, D-SETUP, D-CALL RESTORE or D-INFO PDU. The temporary address shall be a valid layer 2 address in the MS for reception of group addressed messages for the duration of the call.

In addition, if the MS calls a group that is not attached in the MS (i.e. the group address is not a valid layer 2 address) when it is registered in the home SwMI of that group, and if the D-CONNECT PDU does not contain the temporary address element, then the MS shall implicitly assume temporary membership of the called group address for the duration of the call. This temporary membership shall apply only after receipt of the D-CONNECT PDU. However, if the D-CONNECT PDU contains the basic service information element with the communication type sub-element indicating "point to point" then the MS shall not adopt the called address as a temporary address. If the call was set up using a SNA, the calling MS shall not implicitly assume temporary membership of the called group address to which the SNA corresponds; this restriction is imposed because the MS may not know the called group address to which the SNA corresponds, in which case it cannot assume temporary membership of the group.

NOTE 1: If the SwMI is unsure whether the group address for the call is a valid layer 2 address for the calling MS, the SwMI should allocate the group address as a temporary address to the calling MS; this recommendation is made because if the group address for the call is not a valid layer 2 address, and the SwMI doesn't allocate the group address for the call as a temporary address, the MS will participate in the call but will ignore all group addressed call maintenance signalling.

NOTE: 2 In this procedure, if the MS calls a group that it is not a member of (when it is registered in the home SwMI of that group) then it may assume temporary membership of the called group address without having received a temporary address element in the D-CONNECT PDU. If the calling user has made an erroneous selection of communication type then this could result in the calling MS adopting another MS's individual address as a temporary group address. Therefore the SwMI should check that the called address in a requested group call is actually a group address; if it is not then the SwMI should either disconnect the call or correct the communication type to "point to point" when sending the D-CONNECT PDU (the SwMI may also choose to correct the communication type to "point to point" in a D-CALL PROCEEDING, D-INFO or D-ALERT PDU).

The CC sub-entity shall send a CONFIGURE request informing the lower layers of the new temporary address and if required the change of basic service from individual to group call.

When the call is then released, the CC sub-entity shall send a CONFIGURE request informing the lower layers that the temporary group address is not longer valid (see clause 14.5.2.3).

14.5.2.2.7 Calls to and from external subscribers

An external subscriber can call TETRA group numbers. The signalling needed between an external subscriber and a gateway is outside the scope of the present document. The signalling between the SwMI and the called group is the same as that for a mobile originated group call.

14.5.2.3 Call disconnection procedures

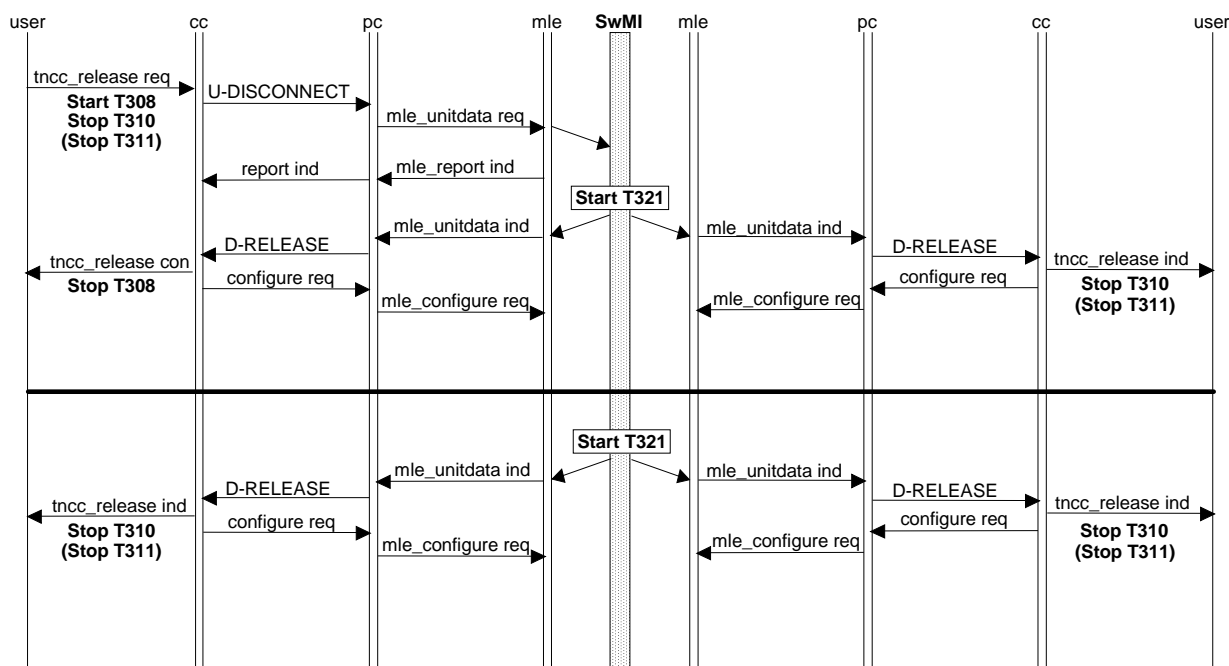


Figure 38: Group call - request-to-disconnect

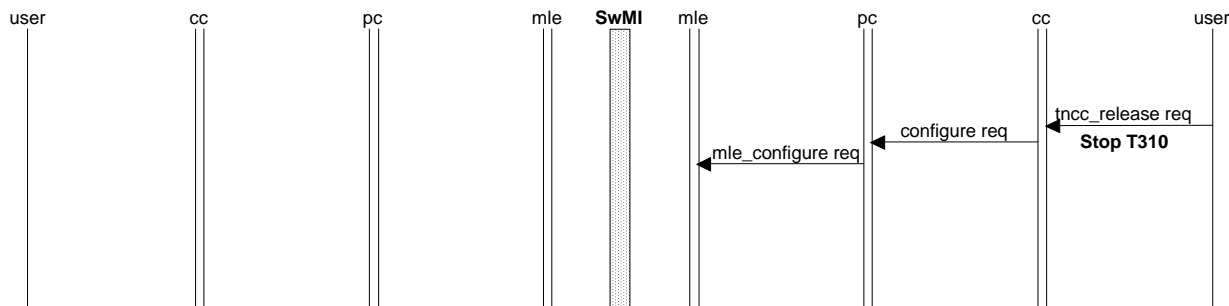


Figure 39: Group call - group member leaves ongoing group call



### 14.5.2.3.1 User initiated disconnection

A user application may initiate call disconnection at any state of a call by sending a TNCC-RELEASE request to the CC sub-entity. A call owner shall signal call disconnection to the SwMI by sending a U-DISCONNECT PDU. A non-call owner shall leave a call without disconnecting it. In that case there shall not be any disconnection related signalling from the MS to the SwMI. The disconnect type parameter in the TNCC-RELEASE request indicates whether the CC should disconnect the call or leave the call without disconnection. Refer to clause 14.5.2.7 for the definition of call ownership.

The following procedures shall apply to the user application that is designated as the call owner, figure 38 refers:

- during call set-up phase until U-SETUP PDU has been transmitted to the SwMI, a disconnection can be handled locally using a CANCEL request. Information regarding the local progress of the transmission of a PDU is received in REPORT indications. After a local cancellation the CC sub-entity shall stop timer T303 and shall return to state IDLE;
- on receipt of a TNCC-RELEASE request in the CC sub-entity from the user application requesting call disconnection, the CC shall send a U-DISCONNECT PDU, start timer T308 and enter state CALL-DISCONNECT. All other T3xx Timers shall be stopped. The progress of the disconnection shall be reported to the CC with REPORT indication;
- Should the user application disconnect the call during the window between transmission of a U-SETUP and reception of a D-CALL PROCEEDING or D-CONNECT (i.e. before the MS/LS has received a call identifier for the call), it shall use the dummy call identifier (all zeroes);
- if a U-DISCONNECT is issued, CC shall await a D-RELEASE PDU. When a D-RELEASE PDU or a REPORT indication with reason PDU transfer failed is received, or timer T308 expires, the CC sub-entity shall clear the call identifier, stop timer T308 and return to state IDLE, issuing a TNCC-RELEASE confirm to the user application. The CC sub-entity shall send a CONFIGURE request to the lower layers to clear the temporary group address (if the temporary address is applicable to the call), switch the U-Plane off, reject any pending channel change response request for that call (refer to clause 14.5.3.2), and leave the assigned channel (if the MS is on an assigned channel when the CONFIGURE request is sent). If a channel change response is required for the D-RELEASE PDU, CC shall accept that channel change (refer to clause 14.5.3.2). The SwMI may also choose to send only a group address D-RELEASE PDU and the CC shall behave as if it had received it individually addressed.

The SwMI should inform the other MS/LSs in the call of the call clearance using a D-RELEASE PDU (see clause 14.5.2.3.3 for MS/LS actions).

If a group participant wishes to leave the group call, without disconnecting the call, the user application shall issue a TNCC-RELEASE request with disconnect type parameter equal to "leave call without disconnection":

- if the user leaves the call without disconnection, the CC sub-entity shall clear the call identifier, stop all T3xx Timers and return to state IDLE, see figure 39. The CC sub-entity shall send a CONFIGURE request to the lower layers to clear the temporary group address (if the temporary address is applicable to the call), switch the U-Plane off, reject any pending channel change response request for that call (refer to clause 14.5.3.2), and leave the assigned channel (if the MS is on an assigned channel when the CONFIGURE request is sent).

### 14.5.2.3.2 Network initiated disconnection

In the case where the SwMI cannot support a request for a call from the calling MS/LS, the SwMI shall send a D-RELEASE PDU containing the reason for disconnection, to the calling MS/LS.

In the case where the SwMI can no longer support an established call, the SwMI should send a D-RELEASE PDU to all the MS/LSs in the group containing the reason for disconnection, and subsequently release the call.

The MS/LS actions are defined in clause 14.5.2.3.3.

### 14.5.2.3.3 Reception of disconnection request

The BS may send a disconnection request at any phase of the call and the MS/LS shall react as follows:

- when the CC sub-entity receives a D-RELEASE PDU the CC shall not send any response;
- the CC shall inform the user application with a TNCC-RELEASE indication, clear the call identifier, stop all T3xx timers and enter state IDLE, refer figure 38. The CC sub-entity shall send a CONFIGURE request to the lower layer to clear the temporary group address (if the temporary address is applicable to the call), switch the U-Plane off, reject any pending channel change response request for that call (refer to clause 14.5.3.2), and leave the assigned channel (if the MS is on an assigned channel when the CONFIGURE request is sent). If a channel change response is required for the D-RELEASE PDU, CC shall accept that channel change (refer to clause 14.5.3.2).

### 14.5.2.3.4 Colliding disconnection

If the CC entity receives a D-RELEASE PDU when CC has just sent a U-DISCONNECT PDU, the CC sub-entity shall release the call immediately as defined in 14.5.2.3.3. In addition, the CC shall issue a CANCEL request to the lower layers to cancel any ongoing re-transmission of the U-DISCONNECT PDU.

### 14.5.2.3.5 Expiry of timers

#### a) Timer T302: call set-up timer for calling MS/LS

Upon expiry of timer T302, CC shall send a TNCC-RELEASE indication primitive to the user application, send a U-DISCONNECT PDU, and follow the procedures in clause 14.5.2.3.1. The value of the disconnect cause element shall be set to "expiry of timer".

#### b) Timer T303: call initiated timer for calling MS/LS

Upon expiry of timer T303, CC shall send a TNCC-RELEASE indication primitive to the user application, send a U-DISCONNECT PDU, and follow the procedures in clause 14.5.2.3.1. The value of the disconnect cause element shall be set to "expiry of timer".

#### c) Timer T307: call restoration timer for point-to-multipoint calls

Upon expiry of timer T307, CC shall apply procedures described in clause 14.5.2.2.4. The value of the disconnect cause element shall be set to "expiry of timer".

#### d) Timer T308: call disconnect timer

Upon expiry of timer T308, CC shall return to state IDLE, send a TNCC-RELEASE confirm primitive to the user application and shall send a CANCEL request to the lower layers to cancel the sending of the U-DISCONNECT PDU. The CC sub-entity shall send a CONFIGURE request to the lower layers to clear the temporary group address (if the temporary address is applicable to the call), switch the U-Plane off, reject any pending channel change response request for that call (refer to clause 14.5.3.2), and leave the assigned channel (if the MS is on an assigned channel when the CONFIGURE request is sent).

#### e) Timer T310: call length timer

Upon expiry of timer T310, if the MS/LS is the call owner, the CC shall send a TNCC-RELEASE indication primitive to the user application, send a U-DISCONNECT PDU and follow the procedures in clause 14.5.2.3.1. The value of the disconnect cause element shall be set to "expiry of timer".

If the MS/LS is not the call owner, CC shall return to state IDLE, and shall send a TNCC-RELEASE indication primitive to the user application and a CONFIGURE request to the lower layers. The value of the disconnect cause element shall be set to "expiry of timer".

#### f) Timer T311: call transmission timer

Refer to clause 14.5.2.2.1 g).

## g) Timer T330: call set-up delay timer

Upon expiry of timer T330 CC can no longer accept the corresponding channel change.

#### 14.5.2.4 U-Plane switching

The U-Plane switching procedure ensures that traffic/signalling synchronization between the CMCE and the MAC shall be maintained during the lifetime of a call. The CC informs the MAC when it has permission to transmit traffic (i.e. TCH or STCH) and when to stop. The CC also informs the MAC when it may process received traffic (and when to stop). The latter procedure also assists the MAC to interpret when the received bit-stream on the assigned channel is TCH/STCH and when it is SCH.

The CC changes the U-plane operation in the MAC by issuing the CONFIGURE request primitive, indicating "Switch U-plane = On" or "Switch U-plane = Off", "Tx grant = true" or "Tx grant = false" and "Simplex/duplex = simplex". There shall be only three valid combinations.

- 1) Switch U-plane = On, Tx grant = true, Simplex/duplex = simplex:
  - MS/LS is authorized to transmit traffic.
- 2) Switch U-plane = On, Tx grant = false, Simplex/duplex = simplex:
  - MS/LS is authorized to receive traffic.
- 3) Switch U-plane = Off:
  - withdraws previous authorization to transmit and/or receive traffic.

##### 14.5.2.4.1 End of call set-up phase

When the CC in a MO call receives a D-CONNECT PDU or when the CC in a MT call receives a D-SETUP PDU, it shall issue a CONFIGURE request primitive to the lower layers containing information about the call e.g. the type of traffic, the interleaving depth, the call identifier and whether the call is end-to-end encrypted.

If the transmission grant element in the D-CONNECT PDU is set to "transmission granted" then the CONFIGURE request shall contain the parameter value "Switch U-Plane = On" and "Tx grant = true" to indicate that the MAC has permission to transmit traffic. If the transmission grant element is set to "transmission granted to another user" then the CONFIGURE request shall contain the parameter value "Switch U-Plane = On" but shall contain "Tx grant = false" to indicate that the MAC should receive traffic. For the other values of the transmission grant element, the U-plane shall not be switched on.

If the transmission grant element in the D-SETUP PDU is set to "transmission granted to another user" then the CONFIGURE request shall contain the parameter value "Switch U-Plane = On" but shall contain "Tx grant = false" to indicate that the MAC should receive traffic. For the other values of the transmission grant element, the U-plane shall not be switched on.

The only valid values of the transmission grant element in a group-addressed PDU shall be "transmission granted to another user" and "transmission not granted".

##### 14.5.2.4.2 During call maintenance phase

###### a) Transmission grant control

When the CC does not have permission to transmit, and if it receives a D-TX GRANTED PDU with the transmission grant element set to "transmission granted" or "transmission granted to another user", then the CC shall send a CONFIGURE request containing the parameter "Switch U-Plane = On" and indicating whether the MAC has permission to transmit traffic ("Tx grant = true" or "Tx grant = false" respectively). For the other values of the transmission grant element, the U-plane state shall not be changed.

While the CC has permission to transmit, it shall ignore group addressed D-TX GRANTED PDUs (see clause 14.5.2.2.1 b)).

#### b) Transmission ceased

When the CC receives a D-TX CEASED PDU or on receipt of a REPORT indication of either successful or unsuccessful transmission of a U-TX CEASED PDU, the CC shall issue a CONFIGURE request containing the parameter value "Switch U-Plane = Off".

#### c) Temporary pause.

When the CC receives a D-TX WAIT PDU, and if the U-plane is currently switched on for either transmission or reception, the CC shall issue a CONFIGURE request containing the parameter value "Switch U-plane = Off".

When the CC receives a D-TX CONTINUE PDU then:

- if the continue element is set to "continue" and the MS/LS had permission to transmit traffic at the time of receipt of the D-TX WAIT PDU, then the CC shall issue a CONFIGURE request containing the parameter values "Switch U-Plane = On" and "Tx grant = true";
- if the continue element is set to "continue" and the MS/LS did not have permission to transmit traffic at the time of receipt of the D-TX WAIT PDU, then the CC shall issue a CONFIGURE request containing the parameter value "Switch U-Plane = On" but containing "Tx grant = false".

If the Continue element is set to "not continue" then the U-plane shall not be switched on.

#### d) Interruption

When the CC receives a D-TX INTERRUPT PDU, and if the transmission grant element is set to "transmission granted to another user", then the CC shall issue a CONFIGURE request containing the parameter value "Switch U-Plane = On" but containing "Tx grant = false" to indicate that the MAC should receive traffic. For the other values of the transmission grant element, the CC shall issue a CONFIGURE request containing the parameter value "Switch U-Plane = Off".

While the CC has permission to transmit, it shall ignore group addressed D-TX INTERRUPT PDUs.

#### e) Call restoration

When CC receives a BREAK indication indicating that a temporary break in the radio link has occurred, the CC shall issue a CONFIGURE request containing the parameter value "Switch U-Plane = Off".

When CC receives a D-CALL-RESTORE PDU indicating that the call has now been restored after a temporary break in the radio link, and if the transmission grant element is set to "transmission granted" or "transmission granted to another user", then the CC shall issue a CONFIGURE request containing the parameter value "Switch U-Plane = On" and indicating whether the MS has permission to transmit traffic ("Tx grant = true" or "Tx grant = false" respectively). For the other values of the transmission grant element, the U-plane shall not be switched on.

#### 14.5.2.4.3 Call disconnection phase

When the CC receives a D-RELEASE PDU, or if it receives a REPORT indication of either successful or unsuccessful transmission of a U-DISCONNECT PDU, or if it receives a TNCC-RELEASE request primitive from the user application indicating that the user wishes to leave the call (without disconnecting the call), then the CC shall issue a CONFIGURE request to the lower layers containing the parameter value "Switch U-Plane = Off".

#### 14.5.2.5 Void

#### 14.5.2.6 Acknowledged group call procedures

The MS/LS procedures for handling of an acknowledged group call shall be in accordance with the procedures described for a normal group call in clauses 14.5.2.1 to 14.5.2.4 with the following additions, which for the SwMI side are informative.

The SwMI should poll the individuals within the called group on the traffic channel after call set-up.

It is an operator option defined in the SwMI if the call should proceed immediately by giving the calling user permission to transmit before, during or after the called members of the group have been polled on the traffic channel.

The SwMI may optionally use one of the following criteria for giving the calling user permission to transmit:

- the D-SETUP PDU has been sent to the called users and the polling will take place in parallel with the ongoing call;
- a certain number of users have responded to the poll;
- all users have been polled.

As a poll request, all MS/LS shall be prepared to receive a D-INFO PDU during the call from the SwMI.

Upon reception of a D-INFO PDU indicating a poll request the CC entity shall send this information further on to the user in a TNCC-NOTIFY and send a U-INFO PDU to the SwMI. The U-INFO shall be sent immediately by the CC on receipt of the poll request, see figure 34.

As an operator option the SwMI may disconnect the call after a certain time if insufficient number of members are present, before the permission to transmit is given.

It is a SwMI option how and when to inform the calling user or any other user the result of the polling. An MS/LS shall, during the call set-up phase or during an ongoing call, be prepared to receive one or more D-INFO PDU with the following alternative poll results:

- percentage of responding number of group members;
- number of responding group members;
- list of identities of the responding group members.

The CC shall send the poll result in the D-INFO PDU to the user application in a TNCC NOTIFY indication.

#### 14.5.2.7 Call ownership

The CC states and state transitions described in this clause are defined in clause 14.4.2.

Upon entry to the MO-CALL-SETUP state from the IDLE state, the MS shall assume it is a call owner.

Upon entry to the MT-CALL-SETUP state from the IDLE state, the MS shall assume it is not a call owner.

Upon entry to the CALL ACTIVE state from the MO-CALL-SETUP state or MT-CALL-SETUP state, the MS shall assume it is not a call owner unless it transitioned to the CALL ACTIVE state as a result of receiving a D-CONNECT PDU with the "Call ownership" element set to "A call owner".

In any non-IDLE state, if a MS which is a call owner receives an individually addressed or group addressed D-INFO PDU with the "Call ownership" element set to "Not a call owner", the MS shall no longer be a call owner. In any non-IDLE state, if a MS which is not a call owner receives an individually addressed or group addressed D-INFO PDU with the "Call ownership" element set to "A call owner", the MS shall become a call owner.

## 14.5.3 Traffic channel assignment procedures

### 14.5.3.1 SwMI related procedures

This clause describes procedures which shall be applicable only to the SwMI. Depending on the traffic case, alternative methods for traffic channel assignment can be used as presented in table 56.

**Table 56: Traffic channel assignment**

TRAFFIC CASE	Early traffic channel assignment	Medium traffic channel assignment	Late traffic channel assignment
Message trunked system; Individual call; On/Off hook signalling;	Yes	Yes	Yes
Message trunked system; Individual call; Direct set-up signalling;	Yes	No	Yes
Transmission trunked system; Individual call; On/Off hook signalling;	No	No	Yes
Transmission trunked system; Individual call; Direct set-up signalling;	No	No	Yes
Quasi-transmission trunked system; Individual call; On/Off hook signalling;	No	No	Yes
Quasi-transmission trunked system; Individual call; Direct set-up signalling;	No	No	Yes
Message trunked system; Group call;	Yes	No	Yes
Transmission trunked system; Group call;	No	No	Yes
Quasi-transmission trunked system; Group call;	No	No	Yes

For the called MSs/LSs in a group call, the traffic channel assignment should always be given along with the D-SETUP PDU.

The following methods are available for assigning a traffic channel to a call:

- Early assignment:
  - the traffic channels are assigned and indicated to the calling and called MS along with the D-CALL PROCEEDING and D-SETUP PDUs respectively (contained in the lower layer part of those messages). In this case the calling MS moves immediately to the traffic channel in anticipation of the call and should receive CC messages on this channel;
- Medium assignment:
  - the traffic channels are assigned and indicated to the calling MS along with the D-ALERT PDU and are indicated to the called MS in a layer 2 acknowledgement to the called MS U-ALERT PDU. In this case the calling MS moves to the traffic channel in anticipation of the call and should receive CC messages on this channel;
- Late assignment individual call:
  - the traffic channels are not assigned until the called MS sends a U-CONNECT PDU. Upon reception of this PDU the traffic channels may be indicated to the calling and called MS along with the D-CONNECT and D-CONNECT ACKNOWLEDGE PDUs respectively. In this case the calling MS shall remain listening on the control channel until it is told to move to the traffic channel;

- Late assignment group call:
  - the traffic channels are not assigned until appropriate conditions are met. These conditions may be as a result of the finite time required to locate group members, or as a result of the call being acknowledged. The traffic channel may be indicated to the calling MS along with the D-CONNECT PDU.

NOTE 1: When a MS is said to be sent to a traffic channel in the text above, it means that the MS is ordered to go to an assigned channel. For early and medium assignment, the assigned channel starts as a FACCH until the MS is instructed to switch the U-plane on. For late assignment, the MS may be instructed to switch the U-plane on when it moves to the assigned channel.

NOTE 2: In this edition of the present document, the implications for the MS-related traffic channel assignment procedures (refer to clause 14.5.3.2) of the traffic channel assignment type used by the SwMI have not been fully considered for the "early" and "medium" channel assignment types.

### 14.5.3.2 MS related procedures

#### 14.5.3.2.1 General procedures

The MAC layer manages radio channel changes as described in clause 23.5.4. It is possible that the MAC layer may receive conflicting channel allocations when the MS is already involved in a service and receives a new service indication. Also, the SwMI may re-allocate radio resources so that concurrent services a MS is using are no longer utilizing resources which are within the capabilities of the MS e.g. sharing the same radio channel. In those situations, the MAC layer needs to ask from the higher layers which channel allocation it will follow so that the preferred service continues or replaces the current service.

The CMCE may receive a "channel change response required" request with any of the following primitives:

##### a) MLE-UNITDATA indication

For this primitive, the channel assignment is associated with a CC PDU; the primitive is derived from a layer 2 TL-DATA indication or TL-UNITDATA indication, refer to clauses 18.3.5.3.1, 20.3.5.1.4, 20.3.5.1.9, 22.2.1.1 and 22.2.1.2.

##### b) MLE-REPORT indication

For this primitive, the channel assignment is associated with a layer 2 acknowledgement; the primitive is derived from a layer 2 TL-DATA confirm, refer to clauses 18.3.5.3.1, 20.3.5.1.4 and 22.2.1.1.

##### c) MLE-CONFIGURE indication

For this primitive, the channel assignment is associated with neither a CC PDU nor a layer 2 acknowledgement; the primitive is derived from a layer 2 TL-REPORT indication, refer to clauses 18.3.5.4, 20.3.5.1.9 and 22.3.5.

NOTE 0: Though the SwMI does not have to send a CC PDU with a traffic channel assignment, it is recommended that the SwMI sends a CC PDU with any channel assignment not sent with a layer 2 acknowledgement in order to facilitate routing of the channel assignment to the correct CC instance. It is recommended that the SwMI use the D-INFO PDU if it sends a CC PDU solely for the purpose of associating a channel assignment with a call.

If a channel change response is required the CMCE shall send a MLE-CONFIGURE request primitive with the "channel change accepted" parameter set to one of the following values (refer to clause 17.3.9):

- accept;
- reject;
- ignore.

NOTE 1: "ignore" is reserved for specific call situations and is not available for other purposes, refer to clause 14.5.3.2.3.

The CC will normally immediately return "accept" when it accepts the service, and "reject" when it does not accept the offered service. The CC may need to return "ignore" in response to a group addressed channel allocation, in which case the response will be immediate, refer to clause 14.5.3.2.3 for a description of those scenarios in which "ignore" is used. In group call case the MS may also delay the sending of the MLE-CONFIGURE request for up to time T330. For late traffic channel assignment, CC shall not reject the channel allocation whilst accepting the service.

NOTE 2: How CMCE or CC entity knows which of the offered or existing services it will accept/select or how it negotiates with other network layers or user application to find out the preferred service is outside the scope of this part of the present document.

NOTE 3: The MAC actions for "reject" and "ignore" are generally the same except for specific situations, see clauses 23.5.4.2.3 and 23.5.4.2.4 for details.

NOTE 4: Handling of channel allocations may also be affected by the MS being active in a MM procedure, this being indicated to CC from MLE via the MLE-BUSY indication primitive, refer to clause 18.3.5.4. The exact nature of the interaction between MM/MLC and CC is outside the scope of this part of the present document but it is recommended that CC not accept a channel allocation while MM is busy.

#### 14.5.3.2.2 Procedures for acceptance of individually-addressed channel allocation

As described in clauses 14.5.1.1.1, 14.5.1.1.3 and 14.5.6.5.3, it is optional whether the MS accepts an incoming individual call. Therefore, when the MAC receives a channel allocation addressed to it, it refers to the higher layers for instruction about whether to accept the channel allocation.

The lower layers indicate that instruction is required by setting the "channel change response required" parameter to "true". This parameter is passed (via LLC, MLE and PC) to CC along with the PDU. If the CC decides to accept the channel allocation then it shall return a CONFIGURE request primitive with the parameter "channel change accepted" set to "accept". The CC may also decide to reject a channel allocation in which case CC shall use "channel change accepted" parameter value "reject". The CC shall decide whether to accept or reject a channel allocation by applying the following rules:

- if the PDU relates to an ongoing call (i.e. if the call identifier in the received PDU is the call identifier of any current call that the MS is active in) and if the CC obeys the received PDU then the CC shall accept the channel change;
- if the PDU relates to an ongoing call and if the CC does not obey the received PDU then the CC shall reject the channel change;
- if the PDU relates to a new service and if the CC obeys the received PDU then the CC shall accept the channel change;
- if the PDU relates to a new service and if the CC does not obey the received PDU then the CC shall reject the channel change.

NOTE: The "ignore" value is not used as a response to any individually addressed channel allocation.

#### 14.5.3.2.3 Procedures for acceptance of group-addressed channel allocation

As described in clause 14.5.2.1.1, it is optional whether the MS accepts an incoming group call. Therefore, when the MAC receives a channel allocation addressed to a group that the MS belongs to, it refers to the higher layers for instruction about whether to accept the channel allocation.

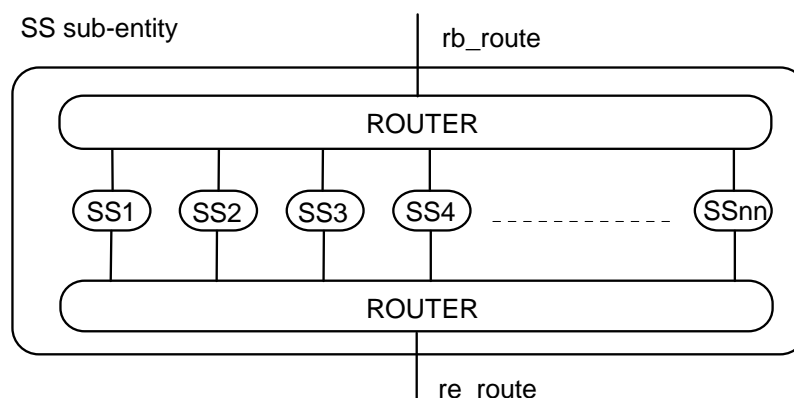
The lower layers indicate that instruction is required by setting the "channel change response required" parameter to "true". This parameter is passed (via LLC, MLE and PC) to CC along with the PDU. If the CC decides to accept the channel allocation then it shall return a CONFIGURE request primitive with the parameter "channel change accepted" set to "accept". The CC may also decide to reject a channel allocation in which case CC shall use "channel change accepted" parameter value "reject". The CC shall decide whether to accept, reject or in specific cases ignore a channel allocation by applying the following rules:

- if the PDU is a group addressed D-SETUP PDU then:
  - if the MS is not currently attempting to call this group then the CC shall accept the channel change if the user application accepts the incoming call using TNCC-SETUP response, refer to clause 14.5.2.1.1 and 14.5.2.1.3 for other actions;



- if the MS is not currently attempting to call this group then the CC shall reject the channel change if the user application rejects the incoming call using TNCC-RELEASE request;
- if the MS is currently attempting to call this group, and has not received a REPORT indication of successful transmission of the U-SETUP PDU from the lower layers, then:
  - if it is requesting a "basic service information" compatible with that in the D-SETUP PDU then it shall send a CANCEL request primitive to the lower layers to stop transmission of the U-SETUP PDU then:
    - if cancellation is successful, the MS shall accept the channel change;
    - if cancellation is unsuccessful, the MS shall ignore the channel change and shall wait on the current channel for further signalling: a D-CALL PROCEEDING and/or D-CONNECT PDU (and/or D-RELEASE PDU).
  - if it is requesting a "basic service information" not compatible with that in the D-SETUP PDU then it shall accept the channel change if the user application accepts the incoming call using TNCC-SETUP response, refer to clause 14.5.2.1.3 for other actions;
  - if it is requesting a "basic service information" not compatible with that in the D-SETUP PDU then it shall reject the channel change if the user application rejects the incoming call using TNCC-RELEASE request.
- if the MS is attempting to call this group and has received a REPORT indication of successful transmission of the U-SETUP PDU by the LLC but not yet received a call identifier then it shall ignore the channel change and shall wait on the current channel for further signalling: a D-CALL PROCEEDING and/or D-CONNECT PDU (and/or D-RELEASE PDU);
- if the MS is attempting to call this group and has received D-CALL PROCEEDING PDU and the call identifier in the D-SETUP PDU is the same as the call identifier in the D-CALL PROCEEDING PDU and the calling party address in the D-SETUP PDU does not contain the MS's own address then the CC shall accept the channel change;
- if the MS is attempting to call this group and has received D-CALL PROCEEDING PDU and the call identifier in the D-SETUP PDU is the same as the call identifier in the D-CALL PROCEEDING PDU and the calling party address in the D-SETUP PDU contains the MS's own address then the CC shall ignore the channel change.
- if the PDU relates to an ongoing call (i.e. if the call identifier in the received PDU is the call identifier of any current call that the MS is active in) and if the CC obeys the received PDU then the CC shall accept the channel change;
- if the PDU relates to an ongoing call and if the CC does not obey the received PDU then:
  - if the MS is transmitting traffic and the PDU is a group addressed D-TX GRANTED or D-TX INTERRUPT PDU then the CC shall ignore the channel change;
  - in all other cases the CC shall reject the channel change.

## 14.5.4 SS procedures



**Figure 40: Internal view of SS sub-entity**

Figure 40 shows the internal architecture of the SS sub-entity. The user application shall communicate with SS entities via the rb-route, when the information of the requested service is not incorporated into TNCC-SAP service primitives, see clauses 11 and 12. All messages to and from PC shall be communicated over the re-route. When a SS message is received from the peer entity, it shall be passed via the SS router to the appropriate SS entity.

Each individual SS entity shall receive and send call related SS messages as facility elements in CC PDUs, or if no other call related PDU is available, in a U/D-INFO PDU. The call identifier element shall link the SS facility element to the related call.

If the SS message is not related to any existing call, it shall be conveyed as a facility element in a U/D-FACILITY PDU.

Some SS messages may be sent or received at any stage of a call, after the call during SS-CC retention time and when no call exists.

## 14.5.5 SDS procedures

The SDS procedures handled by the SDS sub-entity shall be applicable for the MS/LS side. The procedures relating to the SwMI are outside the scope of the present document.

In the SDS protocol there is no relationship defined between SDS messages using different transmission directions and the SDS sub-entity shall be able to handle colliding messages, e.g. shall receive messages to be sent to the peer entity and shall deliver received messages from the peer entity at the same time.

### 14.5.5.1 Incoming short data message

On reception of D-STATUS or D-SDS-DATA PDUs the SDS sub-entity shall inform the user application with a TNSDS-STATUS indication primitive containing the pre-coded status or with a TNSDS-UNITDATA indication primitive containing user defined data, respectively.

### 14.5.5.2 Outgoing short data messages

A user application initiates the SDS message transfer by issuing either a TNSDS-STATUS request primitive or a TNSDS-UNITDATA request primitive. The SDS sub-entity shall select an appropriate PDU priority based on the requested access priority value as described in clause 14.5.6.2.

Upon reception of a TNSDS-STATUS or a TNSDS-UNITDATA request primitive the SDS sub-entity shall send the corresponding U-STATUS or U-SDS-DATA PDU respectively.

The SDS sub-entity shall not accept further short data request primitives from the user application before a REPORT indication indicating successful transmission of the PDU has been received. The received report shall be forwarded to the user application in a TNSDS-REPORT indication.

If the SDS entity receives a REPORT indication informing that the PDU transmission was unsuccessful, the SDS sub-entity shall inform the user application using a TNSDS-REPORT indication with parameter "failure" and the SDS sub-entity may continue to accept new SDS service requests.

## 14.5.6 PC procedures

This clause contains various protocol elements which are common to one or more sub-entities within the CMCE. The description does not define or limit implementations to be inside the PC sub-entity.

### 14.5.6.1 Access to the communication resources

When the MS or LS is powered up all the CMCE sub-entities except the PC sub-entity shall start in state IDLE. The PC sub-entity shall start in state CLOSED. When the PC sub-entity receives a MLE-OPEN indication, the PC sub-entity shall change state to OPEN and inform other sub-entities with an OPEN indication. When the PC is in state CLOSED the other sub-entities shall not send any PDUs. When the PC receives a MLE-CLOSE indication, the PC sub-entity shall change state to CLOSED and shall inform the other sub-entities with a CLOSE indication primitive.

Primitives MLE-BREAK indication, REOPEN indication, RESTORE confirm and RESUME indication shall not change the state of the PC, but PC shall pass those to other sub-entities as defined in clause 14.2.6.

### 14.5.6.2 Access priority handling

When any CMCE sub-entity receives an access priority value in a TNCC, TNSS or TNSDS primitive, the sub-entity shall set the PDU priority value according to the access priority value. If the corresponding PDU priority is not defined by other means, then the sub-entity shall use default values as defined in table 57.

**Table 57: Low/high/emergency PDU priority default values**

PDU	PDU priority	Remark
U-ALERT	2/4/7	Stealing repeats flag not set
U-CALL-RESTORE	5	Stealing repeats flag not set
U-CONNECT	2/4/7	Stealing repeats flag not set
U-DISCONNECT	6	Immediate stealing and Stealing repeats flag set
U-INFO	2/4/7	Stealing repeats flag not set
U-RELEASE	6	Stealing repeats flag not set
U-SETUP	0/4/7	Stealing repeats flag not set
U-STATUS	1/4/7	Stealing repeats flag not set
U-SDS DATA	1/4/7	Stealing repeats flag not set
U-TX-CEASED	6	Immediate stealing and Stealing repeats flag set
U-TX-DEMAND	2/4/7	Stealing repeats flag not set

For PDUs other than U-TX CEASED and U-DISCONNECT, the CC sub-entity shall set the stealing permission parameter according to the following rules:

- if "traffic stealing = steal traffic" and "access priority = emergency" in the service access primitive, the stealing permission parameter shall be set to "steal immediately";
- if "traffic stealing = steal traffic" and access priority is not equal to "emergency" in the service access primitive, the stealing permission parameter shall be set to "steal when convenient";
- otherwise the stealing permission parameter shall be set to "stealing not required".

#### 14.5.6.2.1 Cancel

The cancel procedures may be implemented in an MS and if used the following shall apply:

- the MLE-CANCEL request can minimize the risk of adding extra load to the air interface, e.g. when a user application requests a call set-up and the request is buffered by the lower layers waiting for allowance to make a random access attempt, which in the case of a low priority call and high system load can take a considerable amount of time. If the user application, during this waiting period, changes its decision and wants to disconnect the call, the application shall send a TNCC-RELEASE request to the CC sub-entity. The CC sub-entity shall know the status of the transmission from the REPORT indications received from the lower layers;
- when any sub-entity wishes to stop transmission of a PDU it may use cancel procedure with the limitations defined below. The cancel process shall be controlled by REPORT indications from lower layers;
- incoming MLE-REPORT indications should indicate the following events:
  - a PDU has been stored by the DLL ready for transmission. At this stage the transmission may be cancelled using a CANCEL request and no information will be sent over the air interface;
  - the first transmission of whole PDU. The BS may have received the PDU, but MS has not yet received an acknowledgement. At this stage the layer 2 process may be stopped using a CANCEL request, but the sending sub-entity cannot rely on the cancellation and may receive a response to the sent PDU;
  - the transfer of a PDU has failed in layer 2. Cancellation is no longer possible, but the BS may have received the PDU correctly and the sending sub-entity may receive a response to the sent PDU;
  - a PDU has been successfully transmitted by layer 2. Cancellation is no longer possible.

#### 14.5.6.3 CMCE PDU exchange

The PC shall forward PDUs from the other CMCE sub-entities to MLE using a MLE-UNITDATA request primitive without modifying any parameters supplied with the PDU. However the U-CALL RESTORE PDU shall use a MLE-RESTORE request instead of the MLE-UNITDATA request.

The PC shall forward the SDU contained in a received MLE-UNITDATA indication primitive to the corresponding sub-entity as defined by the PDU type element without modifying any parameters. The D-CALL RESTORE PDU should be received in a MLE-RESTORE confirm primitive instead of the MLE-UNITDATA indication.

##### 14.5.6.3.1 Choice of layer 2 service

When sending the following PDUs, the layer 2 service parameter shall be set to "acknowledged response":

- U-ALERT PDU;
- U-CONNECT PDU for direct call set-up;
- U-DISCONNECT PDU when sent as a response to a D-SETUP PDU;
- U-RELEASE.

For other uplink PDUs, the PC should set the layer 2 service parameter to "acknowledged request".

#### 14.5.6.4 Control information exchange

CMCE sub-entities exchange local control information with the PC using service primitives.

The PC shall forward service primitives from other CMCE sub-entities to the MLE using MLE service primitives as defined in clause 17.3.4 without any modification of the parameters.

The PC shall forward service primitives from MLE, as defined in clause 17.3.4 to the relevant sub-entity or sub-entities without any modification of parameters.

The primitive names and parameters between the PC and the other sub-entities are same as the primitive names at the MLE-SAP except that the "MLE-" is not present.

The CC protocol cannot support overlapping call set-up signalling within the window where the CC awaits a call identifier from the SwMI after a U-SETUP PDU is issued. A method to prevent concurrent call set-up attempt during the window is described as follows:

- when a CC instance initiates a call set-up, it shall inform PC that a call set-up has been initiated, and the PC shall inform other CC instances that currently no more call set-up attempts are possible;
- when the CC instance either receives a call identifier for the new call or discards the call set-up, it shall inform completion of call set-up to the PC, and the PC shall forward that information to the other CC instances.

This method enables correct mapping between the call identifier and the appropriate CC instance.

## 14.5.6.5 PC protocol error conditions

### 14.5.6.5.1 PDU type error

When a PDU is received with a PDU type not recognizable, the MS may, if the PDU is individually addressed, send a CMCE FUNCTION NOT SUPPORTED PDU, refer to clause 14.7.3.2. The MS shall ignore the unrecognizable PDU.

If the MS receives an individually addressed CMCE PDU with a valid PDU type but some unrecognized element or element values prevent the MS from interpreting the PDU correctly, the MS may send a CMCE FUNCTION NOT SUPPORTED PDU.

The behaviour of the requesting party when receiving a CMCE FUNCTION NOT SUPPORTED PDU is outside the scope of the present document.

### 14.5.6.5.2 Invalid call identifier

If a MS receives any individually addressed down link PDU except D-SETUP and D-RELEASE specifying a call identifier element which is not recognized as relating to a call for which a call identifier exists, the PC shall send a U-DISCONNECT PDU with the received invalid call identifier and with the cause "Invalid call identifier".

In all other cases, no action shall be taken by PC.

### 14.5.6.5.3 MS busy

If the MS is engaged in another service or services e.g. circuit mode call or packet data service, and cannot support more concurrent calls and the user application, when it receives an individually addressed D-SETUP PDU, does not release any calls and does not reject the incoming call (refer to clause 14.5.1.1.5), the MS shall send a U-DISCONNECT PDU back to the SwMI with cause "Called party busy".

## 14.5.7 Subscriber class

Where the CMCE receives a MLE-INFO indication which indicates that the subscriber class associated with the ITSI is not valid on a cell the CMCE shall filter service requests until the subscriber class becomes valid, or a new cell is selected where the subscriber class is valid, this being indicated from MLE to CMCE via the MLE-INFO indication primitive. In addition, the CMCE shall only generate PDUs which relate to existing circuit mode calls. The CMCE shall not generate PDUs relating to new calls, unless they have a message priority of 7, indicating an emergency call. If an MS subscriber class is not supported by the current serving cell, the MS shall only be allowed to register on that cell, initiate emergency calls or signalling, and receive incoming calls/signalling on that cell.

## 14.5.8 Activity handling

PC shall send an MLE-ACTIVITY request primitive to the MLE when it receives an ACTIVITY request from a CC entity.

## 14.6 Protocol timers

Table 58 lists the protocol timers and the information associated with them.

**Table 58: Timers**

Timer No.	Timer value	Call state	Cause for start	Normally terminated	Action when timer expires	I/C side	O/G side
T301 see note 1	Maximum 30 s	MT-CALL- Set-up	On the sending of U- Connect, On receipt of D-INFO	On receipt of D-Connect Ack, D-Disconnect, D-Release, Report (failed) ind	Disconnect as specified in clause 14.5.1.3.4 a)	M	-
T302 see note 2	Max. 60 s	MO-CALL- Set-up	On receipt of D-Call Proceeding, D-Alert or D-INFO	On receipt of D-Connect, D-Set-up, D-Disconnect, D-Release, Report (failed) ind	Disconnect as specified in clauses 14.5.1.3.4 b) and 14.5.2.3.5 a)	-	M
T303	60 s	MO-CALL- Set-up	On the sending of U- SETUP	On receipt of D-Call Proceeding, D-Alert, D-Connect, D-Release, Report (failed) ind On transmission of U-Disconnect	Disconnect as specified in clauses 14.5.1.3.4 c) and 14.5.2.3.5 b)	-	M
T306	Min 4 sec Max 6 sec	Break	On sending of U-CALL-Restore (Pt - Pt calls only)	On receipt of D-Call-Restore, Reopen ind	Disconnect as specified in clause 14.5.1.3.4 e)	M	M
T307	Min 2 sec Max 8 sec	Break	On sending of U- CALL-Restore (Pt - MtPt calls only)	Receipt of D-Call-Restore, Reopen ind	Disconnect as specified in clause 14.5.2.3.5 c)	M	M
T308 see note 3	Max. 10 sec	Any State	On transmission of U-Disconnect	Receipt of D-Release, Report (failed) ind	Disconnect as specified in clauses 14.5.1.3.4 f) and 14.5.2.3.5 d)	M	M
T310 see note 4	Min 5 sec No Max. See note	Call Active	On receipt of D-Connect, D-Connect- Acknowledge, D-TX-Continue, D-SETUP (Pt to MtPt calls only), D-INFO, D-Call-Restore	On receipt of D-Release, D-TX-Wait, Report (failed) ind On transmission of U-Disconnect, U-Release	Disconnect as specified in clauses 14.5.1.3.4 g) and 14.5.2.3.5 e)	M	M
T311	Max. 300 sec	Call Active TX	On receipt of D-TX-Granted (transmit), D-TX-Continue (continue) see note 5, D-Connect (transmit), D-Connect Ack (transmit)	On transmission of U-TX Ceased, U-Disconnect On receipt of D-TX Interrupt, D-Release, D-TX-Wait, D-TX-Continue (not continue), Report (failed) ind	Forced Ceased Transmission. Transmission of U-TX Ceased	M	M

Timer No.	Timer value	Call state	Cause for start	Normally terminated	Action when timer expires	I/C side	O/G side
T330	10 sec	MT-CALL-Set-up	On receipt of a channel change response required set to "yes"	On sending corresponding channel change accepted set to any value	CC can no longer accept the channel change	M	-
<p>NOTE 1: This timer is started with a fixed duration of 30 s on the sending of U-Connect; the timer may be started again on receipt of D-INFO (with the duration specified in the D-INFO).</p> <p>NOTE 2: This timer may be started again during the call on receipt of D-INFO.</p> <p>NOTE 3: This timer may have 0 (zero) duration in which case the MS does not wait for D-RELEASE after having sent U-DISCONNECT..</p> <p>NOTE 4: This timer may be started again during the call on receipt of D-INFO or D-Call Restore.</p> <p>NOTE 5: The timer is started as a result of receiving D-TX-Continue (continue) only if the MS had transmit permission when it received D-TX-Wait.</p>							

## 14.7 PDU descriptions

The PDUs detailed within this clause shall be visible at the Um reference point.

Refer to annex E for PDU encoding rules and examples.

**Table 59: Void**

Various supplementary services use the notification information element in some PDUs, refer to EN 300 392-9 [12].

The information contained in the following PDU description tables corresponds to the following key:

- Length: length of the element in bits;
- Type: element type (1, 2, or 3) as defined above;
- Owner: sub-entity responsible for (or owner of) the element data;
- C/O/M: conditional/optional/mandatory information in the PDU;
- Remark: comment.

### 14.7.1 PDU description tables - downlink

#### 14.7.1.1 D-ALERT

- Message: D-ALERT
- Response to: U-SETUP
- Response expected: -
- Short description: This PDU shall be an information to the originating MS/LS that the call is proceeding and the connecting party has been alerted.

**Table 60: D-ALERT PDU contents**

Information element	Length	Type	Owner	C/O/M	Remark
PDU Type	5	1	CC	M	
Call identifier	14	1	CC	M	
Call time-out, set-up phase	3	1	CC	M	
Reserved	1	1	CC	M	see note 1
Simplex/duplex selection	1	1	CC	M	
Call queued	1	1	CC	M	
Basic service information	8	2	CC	O	see note 2
Notification indicator	6	2	SS	O	
Facility		3	SS	O	
Proprietary		3	-	O	
NOTE 1: This information element is not used in this edition of the present document and its value shall be set to "1" (equivalent to "Hook on/Hook off signalling" for backwards compatibility with edition 1 of the present document - refer to table 110).					
NOTE 2: If different from requested.					

### 14.7.1.2 D-CALL PROCEEDING

- Message: D-CALL PROCEEDING
- Response to: U-SETUP
- Response expected: -
- Short description: This PDU shall be the acknowledgement from the infrastructure to call set-up request indicating that the call is proceeding.

**Table 61: D-CALL PROCEEDING PDU contents**

Information element	Length	Type	Owner	C/O/M	Remark
PDU Type	5	1	CC	M	
Call identifier	14	1	CC	M	
Call time-out, set-up phase	3	1	CC	M	
Hook method selection	1	1	CC	M	
Simplex/duplex selection	1	1	CC	M	
Basic service information	8	2	CC	O	see note
Call status	3	2	CC	O	
Notification indicator	6	2	SS	O	
Facility		3	SS	O	
Proprietary		3	-	O	
NOTE: If different from requested.					

### 14.7.1.3 D-CALL RESTORE

- Message: D-CALL RESTORE
- Response to: U-CALL RESTORE
- Response expected: -
- Short description: This PDU shall indicate to the MS/LS that a call has been restored after a temporary break of the call.



Table 62: D-CALL RESTORE PDU contents

Information element	Length	Type	Owner	C/O/M	Remark
PDU Type	5	1	CC	M	
Call identifier	14	1	CC	M	
Transmission grant	2	1	CC	M	
Transmission request permission	1	1	CC	M	
Reset call time-out timer (T310)	1	1	CC	M	
New call identifier	14	2	CC	O	
Call time-out	4	2	CC	O	
Call status	3	2	CC	O	
Modify	9	2	CC	O	
Notification indicator	6	2	SS	O	
Facility		3	SS	O	
Temporary address		3	CC	O	
DM-MS address		3	CC	O	
Proprietary		3	-	O	

#### 14.7.1.4 D-CONNECT

- Message: D-CONNECT
- Response to: U-SETUP
- Response expected: -
- Short description: This PDU shall be the order to the calling MS/LS to through-connect.

Table 63: D-CONNECT PDU contents

Information element	Length	Type	Owner	C/O/M	Remark
PDU Type	5	1	CC	M	
Call identifier	14	1	CC	M	
Call time-out	4	1	CC	M	
Hook method selection	1	1	CC	M	
Simplex/duplex selection	1	1	CC	M	
Transmission grant	2	1	CC	M	
Transmission request permission	1	1	CC	M	
Call ownership	1	1	CC	M	
Call priority	4	2	CC	O	
Basic service information	8	2	CC	O	see note
Temporary address	24	2	CC	O	
Notification indicator	6	2	SS	O	
Facility		3	SS	O	
Proprietary		3	-	O	
NOTE: If different from requested.					

#### 14.7.1.5 D-CONNECT ACKNOWLEDGE

- Message: D-CONNECT ACKNOWLEDGE
- Response to: U-CONNECT
- Response expected: -
- Short description: This PDU shall be the order to the called MS/LS to through-connect.

**Table 64: D-CONNECT ACKNOWLEDGE PDU contents**

Information element	Length	Type	Owner	C/O/M	Remark
PDU Type	5	1	CC	M	
Call identifier	14	1	CC	M	
Call time-out	4	1	CC	M	
Transmission grant	2	1	CC	M	
Transmission request permission	1	1	CC	M	
Notification indicator	6	2	SS	O	
Facility		3	SS	O	
Proprietary		3	-	O	

#### 14.7.1.6 D-DISCONNECT

- Message: D-DISCONNECT
- Response to: -
- Response expected: U-RELEASE
- Short description: This PDU shall be the disconnect request message sent from the infrastructure to the MS/LS.

**Table 65: D-DISCONNECT PDU contents**

Information element	Length	Type	Owner	C/O/M	Remark
PDU Type	5	1	CC	M	
Call identifier	14	1	CC	M	
Disconnect cause	5	1	CC	M	
Notification indicator	6	2	SS	O	
Facility		3	SS	O	
Proprietary		3	-	O	

#### 14.7.1.7 D-FACILITY

- Message: D-FACILITY
- Response to: -
- Response expected: -
- Short description: This PDU shall be used to send call unrelated SS information.

**Table 66: D-FACILITY PDU contents**

Information element	Length	Type	Owner	C/O/M	Remark
PDU Type	5	1	SS	M	see note

NOTE: Contents of this PDU shall be defined by SS protocols.

#### 14.7.1.8 D-INFO

- Message: D-INFO
- Response to: -
- Response expected: -
- Short description: This PDU shall be the general information message to the MS/LS.

Table 67: D-INFO PDU contents

Information element	Length	Type	Owner	C/O/M	Remark
PDU Type	5	1	CC	M	
Call identifier	14	1	CC	M	see note 1
Reset call time-out timer (T310)	1	1	CC	M	
Poll request	1	1	CC	M	see note 2
New call identifier	14	2	CC	O	
Call time-out	4	2	CC	O	
Call time-out set-up phase (T301, T302)	3	2	CC	O	
Call ownership	1	2	CC	O	
Modify	9	2	CC	O	
Call status	3	2	CC	O	
Temporary address	24	2	CC	O	
Notification indicator	6	2	SS	O	
Poll response percentage	6	2	CC	O	see note 3
Poll response number	6	2	CC	O	see note 3
DTMF		3	CC	O	
Facility		3	SS	O	
Poll response addresses		3	CC	O	see note 3
Proprietary		3	-	O	

NOTE 1: If the message is sent connectionless the call identifier shall be the dummy call identifier.  
NOTE 2: Shall be valid for acknowledged group call only. For other types of calls it shall be set = 0.  
NOTE 3: Shall be valid for acknowledged group call only.

#### 14.7.1.9 D-RELEASE

- Message: D-RELEASE
- Response to: -/U-DISCONNECT
- Response expected: -
- Short description: This PDU shall be a message from the infrastructure to the MS/LS to inform that the connection has been released.

Table 68: D-RELEASE PDU contents

Information element	Length	Type	Owner	C/O/M	Remark
PDU Type	5	1	CC	M	
Call identifier	14	1	CC	M	
Disconnect cause	5	1	CC	M	
Notification indicator	6	2	SS	O	
Facility		3	SS	O	
Proprietary		3	-	O	

#### 14.7.1.10 D-SDS-DATA

- Message: D-SDS-DATA
- Response to: -
- Response expected: -
- Short description: This PDU shall be for receiving user defined SDS data.

Table 69: D-SDS-DATA PDU contents

Information element	Length	Type	Owner	C/O/M	Remark
PDU Type	5	1	SDS	M	
Calling party type identifier	2	1	SDS	M	
Calling party address SSI	24		SDS	C	see note 1
Calling party extension	24		SDS	C	see note 1
Short data type identifier	2	1	SDS	M	
User defined data-1	16		SDS	C	see note 2
User defined data-2	32		SDS	C	see note 2
User defined data-3	64		SDS	C	see note 2
Length indicator	11		SDS	C	see note 2
User defined data-4			SDS	C	see note 2
External subscriber number		3	SDS	O	
DM-MS address		3	CC	O	
NOTE 1: Shall be conditional on the value of Calling Party Type Identifier (CPTI): - CPTI = 1; Calling Party SSI; - CPTI = 2; Calling Party SSI + Calling Party Extension.					
NOTE 2: Shall be conditional on the value of Short Data Type Identifier (SDTI): - SDTI = 0; User Defined Data-1; - SDTI = 1; User Defined Data-2; - SDTI = 2; User Defined Data-3; - SDTI = 3; Length Indicator + User Defined Data-4.					

#### 14.7.1.11 D-STATUS

- Message: D-STATUS
- Response to: -
- Response expected: -
- Short description: This PDU shall be the PDU for receiving a pre-coded status message.

Table 70: D-STATUS PDU contents

Information element	Length	Type	Owner	C/O/M	Remark
PDU Type	5	1	SDS	M	
Calling party type identifier	2	1	SDS	M	
Calling party address SSI	24		SDS	C	see note
Calling party extension	24		SDS	C	see note
Pre-coded status	16	1	SDS	M	
External subscriber number		3	SDS	O	
DM-MS address		3	CC	O	
NOTE: Shall be conditional on the value of Calling Party Type Identifier (CPTI): - CPTI = 1; Calling Party SSI; - CPTI = 2; Calling Party SSI + Calling Party Extension.					

#### 14.7.1.12 D-SETUP

- Message: D-SETUP
- Response to: -
- Response expected: U-ALERT/U-CONNECT/-
- Short description: This PDU shall be the call set-up message sent to the called MS/LS.

Table 71: D-SETUP PDU contents

Information element	Length	Type	Owner	C/O/M	Remark
PDU Type	5	1	CC	M	
Call identifier	14	1	CC	M	
Call time-out	4	1	CC	M	
Hook method selection	1	1	CC	M	
Simplex/duplex selection	1	1	CC	M	
Basic service information	8	1	CC	M	
Transmission grant	2	1	CC	M	
Transmission request permission	1	1	CC	M	
Call priority	4	1	SS	M	see note 1
Notification indicator	6	2	SS	O	
Temporary address	24	2	CC	O	
Calling party type identifier	2	2	CC	O	see note 2
Calling party address SSI	24		CC	C	see note 3
Calling party extension	24		CC	C	see note 3
External subscriber number		3	CC	O	
Facility		3	SS	O	
DM-MS address		3	CC	O	
Proprietary		3	-	O	
NOTE 1: This information element is used by SS-PC, refer to EN 300 392-12-10 [43] and SS-PPC and EN 300 392-12-16 [44]					
NOTE 2: For resolution of possible Facility (Talking Party Identifier) / Calling party identifier conflicts, refer to EN 300 392-12-3 [17] clause 5.2.1.5 and EN 300 392-12-1 [16] clause 4.3.5.					
NOTE 3: Shall be conditional on the value of Calling Party Type Identifier (CPTI): - CPTI = 1; Calling Party SSI; - CPTI = 2; Calling Party SSI + Calling Party Extension.					

#### 14.7.1.13 D-TX CEASED

- Message: D-TX CEASED
- Response to: U-TX CEASED
- Response expected: -
- Short description: This PDU shall be the PDU from the SwMI to all MS/LS within a call that a transmission has ceased.

Table 72: D-TX CEASED PDU contents

Information element	Length	Type	Owner	C/O/M	Remark
PDU Type	5	1	CC	M	
Call identifier	14	1	CC	M	
Transmission request permission	1	1	CC	M	
Notification indicator	6	2	SS	O	
Facility		3	SS	O	
DM-MS address		3	CC	O	
Proprietary		3	-	O	

#### 14.7.1.14 D-TX CONTINUE

- Message: D-TX CONTINUE
- Response to: -
- Response expected: -
- Short description: This PDU shall be the information from the SwMI to the MS/LS that the interruption of the call has ceased.

Table 73: D-TX CONTINUE PDU contents

Information element	Length	Type	Owner	C/O/M	Remark
PDU Type	5	1	CC	M	
Call identifier	14	1	CC	M	
Continue	1	1	CC	M	
Transmission request permission	1	1	CC	M	
Notification indicator	6	2	SS	O	
Facility		3	SS	O	
DM-MS address		3	CC	O	
Proprietary		3	-	O	

#### 14.7.1.15 D-TX GRANTED

- Message: D-TX GRANTED
- Response to: U-TX DEMAND
- Response expected: -
- Short description: This PDU shall inform the MS/LS concerned with a call that permission to transmit has been granted by the SwMI to a MS/LS, and to inform that MS/LS that it has been granted permission to transmit. This PDU shall also inform a MS/LS that its request to transmit has been rejected or queued.

Table 74: D-TX GRANTED PDU contents

Information element	Length	Type	Owner	C/O/M	Remark
PDU Type	5	1	CC	M	
Call identifier	14	1	CC	M	
Transmission grant	2	1	CC	M	
Transmission request permission	1	1	CC	M	
Encryption control	1	1	CC	M	
Reserved	1	1	CC	M	see note 1
Notification indicator	6	2	SS	O	
Transmitting party type identifier	2	2	CC	O	
Transmitting party address SSI	24		CC	C	see note 2
Transmitting party extension	24		CC	C	see note 2
External subscriber number		3	CC	O	
Facility		3	SS	O	
DM-MS address		3	CC	O	
Proprietary		3	-	O	

NOTE 1: This information element is not used in this version of the present document and its value shall be set to "0".

NOTE 2: Shall be conditional on the value of Transmitting Party Type Identifier (TPTI):  
- TPTI = 1; Transmitting Party SSI;  
- TPTI = 2; Transmitting Party SSI + Transmitting Party Extension.

#### 14.7.1.16 D-TX INTERRUPT

- Message: D-TX INTERRUPT
- Response to: -
- Response expected: -
- Short description: This PDU shall be a message from the SwMI indicating that a permission to transmit has been withdrawn.

**Table 75: D-TX INTERRUPT PDU contents**

Information element	Length	Type	Owner	C/O/M	Remark
PDU Type	5	1	CC	M	
Call identifier	14	1	CC	M	
Transmission grant	2	1	CC	M	
Transmission request permission	1	1	CC	M	
Encryption control	1	1	CC	M	
Reserved	1	1	CC	M	see note 1
Notification indicator	6	2	SS	O	
Transmitting party type identifier	2	2	CC	O	
Transmitting party address SSI	24		CC	C	see note 2
Transmitting party extension	24		CC	C	see note 2
External subscriber number		3	CC	O	
Facility		3	SS	O	
DM-MS address		3	CC	O	
Proprietary		3	-	O	
NOTE 1: This information element is not used in this version of the present document and its value shall be set to "0".					
NOTE 2: Shall be conditional on the value of Transmitting Party Type Identifier (TPTI): TPTI = 1; Transmitting Party SSI; TPTI = 2; Transmitting Party SSI + Transmitting Party Extension.					

#### 14.7.1.17 D-TX WAIT

- Message: D-TX WAIT
- Response to: U-TX DEMAND
- Response expected: -
- Short description: This PDU shall be a message from the SwMI that the call is being interrupted.

**Table 76: D-TX WAIT PDU contents**

Information element	Length	Type	Owner	C/O/M	Remark
PDU Type	5	1	CC	M	
Call identifier	14	1	CC	M	
Transmission request permission	1	1	CC	M	
Notification indicator	6	2	SS	O	
Facility		3	SS	O	
DM-MS address		3	CC	O	
Proprietary		3	-	O	

### 14.7.2 PDU description tables - uplink

#### 14.7.2.1 U-ALERT

- Message: U-ALERT
- Response to: D-SETUP
- Response expected: -
- Short description: This PDU shall be a acknowledgement from the called MS/LS that the called user has been alerted.

**Table 77: U-ALERT PDU contents**

Information element	Length	Type	Owner	C/O/M	Remark
PDU Type	5	1	CC	M	
Call identifier	14	1	CC	M	
Reserved	1	1	CC	M	see note
Simplex/duplex selection	1	1	CC	M	
Basic service information	8	2	CC	O	
Facility		3	SS	O	
Proprietary		3	-	O	
NOTE: This information element is not used in this edition of the present document and its value shall be set to "1" (equivalent to "Hook on/Hook off signalling" for backwards compatibility with edition 1 of the present document - refer to table 110).					

### 14.7.2.2 U-CALL RESTORE

- Message: U-CALL RESTORE
- Response to: -
- Response expected: D-CALL RESTORE
- Short description: This PDU shall be the order from the MS/LS for restoration of a specific call after a temporary break of the call.

**Table 78: U-CALL RESTORE PDU contents**

Information element	Length	Type	Owner	C/O/M	Remark
PDU Type	5	1	CC	M	
Call identifier	14	1	CC	M	
Request to transmit/send data	1	1	CC	M	
Other party type identifier	2	1	CC	M	
Other party short number address	8		CC	C	see notes 1 and 2
Other party SSI	24		CC	C	see note 1
Other party extension	24		CC	C	see note 1
Basic service information	8	2	CC	M	see note 3
Facility		3	SS	O	
DM-MS address		3	CC	O	
Proprietary		3	-	O	
NOTE 1: Shall be conditional on the value of Called Party Type Identifier (CPTI): - CPTI = 0; Called Party SNA; - CPTI = 1; Called Party SSI; - CPTI = 2; Called Party SSI + Called Party Extension.					
NOTE 2: A use of SNA in call restoration is strongly discouraged as all other call maintenance signalling uses SSI and the SS-SNA may not be supported in all networks.					
NOTE 3: Although the coding of this information element is of type 2 the element is mandatory. The information element informs the new cell of the basic service of the current call in progress.					

### 14.7.2.3 U-CONNECT

- Message: U-CONNECT
- Response to: D-SETUP
- Response expected: D-CONNECT ACKNOWLEDGE
- Short description: This PDU shall be the acknowledgement to the SwMI that the called MS/LS is ready for through-connection.



**Table 79: U-CONNECT PDU contents**

Information element	Length	Type	Owner	C/O/M	Remark
PDU Type	5	1	CC	M	
Call identifier	14	1	CC	M	
Hook method selection	1	1	CC	M	
Simplex/duplex selection	1	1	CC	M	
Basic service information	8	2	CC	O	
Facility		3	SS	O	
Proprietary		3	-	O	

#### 14.7.2.4 U-DISCONNECT

- Message: U-DISCONNECT
- Response to: -
- Response expected: D-DISCONNECT/D-RELEASE
- Short description: This PDU shall be the MS/LS request to the SwMI to disconnect a call.

**Table 80: U-DISCONNECT PDU contents**

Information element	Length	Type	Owner	C/O/M	Remark
PDU Type	5	1	CC	M	
Call identifier	14	1	CC	M	
Disconnect cause	5	1	CC	M	
Facility		3	SS	O	
Proprietary		3	-	O	

#### 14.7.2.5 U-FACILITY

- Message: U-FACILITY
- Response to: -
- Response expected: -
- Short description: This PDU shall be used to send call unrelated SS information.

**Table 81: U-FACILITY PDU contents**

Information element	Length	Type	Owner	C/O/M	Remark
PDU Type	5	1	SS	M	see note
NOTE: Contents of this PDU shall be defined by SS protocols.					

#### 14.7.2.6 U-INFO

- Message: U-INFO
- Response to: -
- Response expected: -
- Short description: This PDU shall be the general information message from the MS/LS.

**Table 82: U-INFO PDU contents**

Information element	Length	Type	Owner	C/O/M	Remark
PDU Type	5	1	CC	M	
Call identifier	14	1	CC	M	see note 1
Poll response	1	1	CC	M	see note 2
Modify	9	2	CC	O	
DTMF		3	CC	O	
Facility		3	SS	O	
Proprietary		3	-	O	

NOTE 1: If the message is sent connectionless then the call identifier shall be equal to the dummy call identifier.  
NOTE 2: Shall be valid for acknowledged group call only. For other types of call it shall be set equal to zero.

### 14.7.2.7 U-STATUS

- Message: U-STATUS
- Response to: -
- Response expected: -
- Short description: This PDU shall be used for sending a pre-coded status message.

**Table 83: U-STATUS PDU contents**

Information element	Length	Type	Owner	C/O/M	Remark
PDU Type	5	1	SDS	M	
Area selection	4	1	SS	M	see note 1
Called party type identifier	2	1	SDS	M	Short/SSI/TSI
Called party short number address	8		SDS	C	see note 2
Called party SSI	24		SDS	C	see note 2
Called party extension	24		SDS	C	see note 2
Pre-coded status	16	1	SDS	M	
External subscriber number		3	SDS	O	
DM-MS address		3	CC	O	

NOTE 1: This information element is used by SS-AS, refer to EN 300 392-12-8 [34].  
NOTE 2: Shall be conditional on the value of Called Party Type Identifier (CPTI):  
- CPTI = 0; Called Party SNA; refer to ETS 300 392-10-7 [42]  
- CPTI = 1; Called Party SSI;  
- CPTI = 2; Called Party SSI + Called Party Extension.

### 14.7.2.8 U-SDS-DATA

- Message: U-SDS-DATA
- Response to: -
- Response expected: -
- Short description: This PDU shall be for sending user defined SDS data.

Table 84: U-SDS-DATA PDU contents

Information element	Length	Type	Owner	C/O/M	Remark
PDU Type	5	1	SDS	M	
Area selection	4	1	SS	M	see note 1
Called party type identifier	2	1	SDS	M	Short/SSI/TSI
Called party short number address	8		SDS	C	see note 2
Called party SSI	24		SDS	C	see note 2
Called party extension	24		SDS	C	see note 2
Short data type identifier	2	1	SDS	M	see note 4
User defined data-1	16		SDS	C	see notes 3 and 4
User defined data-2	32		SDS	C	see notes 3 and 4
User defined data-3	64		SDS	C	see notes 3 and 4
Length indicator	11		SDS	C	see note 3
User defined data-4			SDS	C	see notes 3 and 5
External subscriber number		3	SDS	O	
DM-MS address		3	CC	O	

NOTE 1: This information element is used by SS-AS, refer to EN 300 392-12-8 [34].

NOTE 2: Shall be conditional on the value of Called Party Type Identifier (CPTI):

- CPTI = 0; Called Party SNA; refer to ETS 300 392-10-7 [42] ;
- CPTI = 1; Called Party SSI;
- CPTI = 2; Called Party SSI + Called Party Extension.

NOTE 3: Shall be conditional on the value of Short Data Type Identifier (SDTI):

- SDTI = 0; User Defined Data-1;
- SDTI = 1; User Defined Data-2;
- SDTI = 2; User Defined Data-3;
- SDTI = 3; Length indicator + User Defined Data-4.

NOTE 4 Any combination of address and user defined data type is allowed. However, the intention is to fit TNSDS-UNITDATA request into one subslot when possible. It is recommended that always the shortest appropriate user defined data type is used. One subslot signalling is possible by using one of the following combinations:

- Short Number Address and User Defined Data 1 or 2;
- Short Subscriber Identity and User Defined Data 1.

NOTE 5 The length of user defined data 4 is between 0 and 2 047 bits. However, if the basic link is to be used, then the longest recommended length of the user defined data 4 is 1 017 bits while using Short Subscriber Identity and FCS (See clause 23.4.2.1, see note 2).

#### 14.7.2.9 U-RELEASE

- Message: U-RELEASE
- Response to: D-DISCONNECT
- Response expected: -
- Short description: This PDU shall be the acknowledgement to a disconnection.

Table 85: U-RELEASE PDU contents

Information element	Length	Type	Owner	C/O/M	Remark
PDU Type	5	1	CC	M	
Call identifier	14	1	CC	M	
Disconnect cause	5	1	CC	M	
Facility		3	SS	O	
Proprietary		3	-	O	

## 14.7.2.10 U-SETUP

- Message: U-SETUP
- Response to: -
- Response expected: D-CALL PROCEEDING/D-ALERT/D-CONNECT
- Short description: This PDU shall be the request for a call set-up from a MS/LS.

Table 86: U-SETUP PDU contents

Information element	Length	Type	Owner	C/O/M	Remark
PDU Type	5	1	CC	M	
Area selection	4	1	SS	M	see note 1
Hook method selection	1	1	CC	M	
Simplex/duplex selection	1	1	CC	M	
Basic service information	8	1	CC	M	
Request to transmit/send data	1	1	CC	M	
Call priority	4	1	SS	M	see note 2
CLIR control	2	1	SS	M	see note 3
Called party type identifier	2	1	CC	M	Short/SSI/TSI
Called party short number address	8		CC	C	see note 4
Called party SSI	24		CC	C	see note 4
Called party extension	24		CC	C	see note 4
External subscriber number		3	CC	O	
Facility		3	SS	O	
DM-MS address		3	CC	O	
Proprietary		3	-	O	
NOTE 1: This information element is used by SS-AS, refer to EN 300 392-12-8 [34].					
NOTE 2: This information element is used by SS-PC, refer to EN 300 392-12-10 [43] and SS-PPC, refer to EN 300 392-12-16 [44].					
NOTE 3: Refer to EN 300 392-12-1 [16].					
NOTE 4: Shall be conditional on the value of Called Party Type Identifier (CPTI):					
- CPTI = 0; Called Party SNA; refer to ETS 300 392-10-7 [42] ;					
- CPTI = 1; Called Party SSI;					
- CPTI = 2; Called Party SSI + Called Party Extension.					

## 14.7.2.11 U-TX CEASED

- Message: U-TX CEASED
- Response to: -
- Response expected: D-TX CEASED/D-TX GRANTED/D-TX WAIT
- Short description: This PDU shall be the message to the SwMI that a transmission has ceased.

Table 87: U-TX CEASED PDU contents

Information element	Length	Type	Owner	C/O/M	Remark
PDU Type	5	1	CC	M	
Call identifier	14	1	CC	M	
Facility		3	SS	O	
DM-MS address		3	CC	O	
Proprietary		3	-	O	

### 14.7.2.12 U-TX DEMAND

- Message: U-TX DEMAND
- Response to: D-TX GRANTED
- Response expected: -
- Short description: This PDU shall be the message to the SwMI that a transmission is requested.

**Table 88: U-TX DEMAND PDU contents**

Information element	Length	Type	Owner	C/O/M	Remark
PDU Type	5	1	CC	M	
Call identifier	14	1	CC	M	
TX demand priority	2	1	CC	M	
Encryption control	1	1	CC	M	
Reserved	1	1	CC	M	see note
Facility		3	SS	O	
DM-MS address		3	CC	O	
Proprietary		3	-	O	
NOTE: This information element is not used in this version of the present document and its value shall be set to "0".					

## 14.7.3 PDU description tables - downlink and uplink

### 14.7.3.1 General rules for function not supported

The PDU defined in clause 14.7.3.2 may be used to indicate to the peer entity that the received PDU is not supported. Is shall be used only as a response to individually addressed PDUs.

### 14.7.3.2 CMCE FUNCTION NOT SUPPORTED

- Message: CMCE FUNCTION NOT SUPPORTED
- Response to: Any individually addressed CMCE PDU
- Response expected: -
- Short description: This PDU may be sent by the MS/LS or SwMI to indicate that the received PDU is not supported.

**Table 88a: CMCE FUNCTION NOT SUPPORTED PDU contents**

Information element	Length	Type	Owner	C/O/M	Remark
PDU type	5	1	CC	M	see note 1
Not-supported PDU type	5	1	CC	M	see note 2
Call identifier present	1	1	CC	M	
Call identifier	14		CC	C	see note 3
Function-not-supported pointer	8	1	CC	M	see note 4
Length of received PDU extract	8		CC	C	see note 5
Received PDU extract	Variable		CC	C	see notes 5 and 6
NOTE 1: This information element shall have value "CMCE FUNCTION NOT SUPPORTED" as specified in clause 14.8.28.					
NOTE 2: This information element shall identify the PDU which contains the function which cannot be supported. The element shall have one of the values specified in clause 14.8.28.					
NOTE 3: This information element shall be present if the value of the Call identifier present information element is "1"; this information element shall not be present if the value of the Call identifier present information element is "0" (zero).					
NOTE 4: Element can have any value from 0 to 255 <sub>10</sub> ; if non-zero, shall point to the first bit of the element in the received PDU which indicates the function that cannot be supported by the receiving entity. If zero, shall indicate that the PDU type itself (and hence the entire PDU specified by the "Not-supported PDU type" element) cannot be supported.					
NOTE 5: Shall be conditional on the value of Function-not-supported pointer: if Function-not-supported pointer is non-zero, this element shall be present; if Function-not-supported pointer is zero, this element shall not be present.					
NOTE 6: The total length of this element should be not less than the value of Function-not-supported pointer plus enough bits to identify the element in the received PDU which indicates the function that cannot be supported. This element shall not contain the PDU Type element of the received PDU because this is already specified by the "Not-supported PDU type" element (see note 2).					

## 14.8 Information elements coding

Any of the following elements can be coded as Type 1, 2 or 3 depending on the PDU (see clause 14.7).

### 14.8.1 Area Selection

The area selection information element shall indicate to the SwMI the distribution of the call as defined in table 89. The SS-AS uses this information element, refer to EN 300 392-12-8 [34].

**Table 89: Area selection information element contents**

Information element	Length	Value	Remark
Area Selection	4	0000 <sub>2</sub>	Area not defined using this information element
		0001 <sub>2</sub>	Refer to EN 300 392-12-8 [34]
		...etc.	...etc.
		1111 <sub>2</sub>	Refer to EN 300 392-12-8 [34]

## 14.8.2 Basic service information

The basic service information element shall inform the other communication party what basic service is requested as defined in table 90. The total element length shall be 8 bits.

**Table 90: Basic service information element contents**

Information sub-element	Length	Type	C/O/M	Remark
Circuit mode type	3	1	M	
Encryption flag	1	1	M	
Communication type	2	1	M	
Slots per frame	2		C	see note
Speech service	2		C	see note
NOTE: Shall be conditional on the value of Circuit mode type:				
- Circuit mode type = $000_2$ (Speech); Speech service;				
- Circuit mode type = any other value; Slots per frame.				

## 14.8.3 Call identifier

The call identifier information element shall uniquely identify a specific call as defined in table 91.

**Table 91: Call identifier information element contents**

Information element	Length	Value	Remark
Call identifier	14	0	Dummy call identifier
		$1_{10} - 16\ 383_{10}$	Identifies call uniquely

### 14.8.3a Call identifier present

The call identifier present information element shall indicate presence or otherwise of the call identifier element, as defined in table 91a.

**Table 91a: Call identifier present information element contents**

Information element	Length	Value	Remark
Call identifier present	1	0	Call identifier element not present
		1	Call identifier element present

## 14.8.4 Call ownership

The call ownership information element in a group call shall indicate to the MS whether it is capable to disconnect the call or not as defined in table 92. In individual call it indicates to both parties if it is a normal call set-up or if it is amalgamated call.

**Table 92: Call ownership information element contents**

Information element	Length	Value	Remark
Call ownership	1	0	Not a call owner (Group call); Normal call set-up (Individual call)
		1	A call owner (Group call); Amalgamated call (Individual call)

## 14.8.5 Called party type identifier

The called party type identifier information element shall indicate the type of address which shall follow in the PDU as defined in table 93.

**Table 93: Called party type identifier information element contents**

Information element	Length	Value	Remark
Called party type identifier	2	00 <sub>2</sub>	Short Number Address (SNA)
		01 <sub>2</sub>	Short Subscriber Identity (SSI)
		10 <sub>2</sub>	TETRA Subscriber Identity (TSI)
		11 <sub>2</sub>	Reserved

## 14.8.6 Called party SNA

The called party SNA element shall indicate to the SwMI the SNA of the called user as defined in table 94.

**Table 94: Called party SNA information element contents**

Information element	Length	Value	Remark
Called party Short Number Address	8	0 - 255 <sub>10</sub>	See ETS 300 392-12-7 [45]

## 14.8.7 Called party extension

The called party extension information element shall be to indicate to the SwMI the extended part of the TSI address of the called user as defined in table 95.

**Table 95: Called party extension information element contents**

Information sub-element	Length	Value	Remark
Country Code	10		See EN 300 392-1 [9], clause 7
Network Code	14		See EN 300 392-1 [9], clause 7

## 14.8.8 Called party SSI

The Called party SSI information element shall indicate to the SwMI the SSI address of the called user as defined in table 96.

**Table 96: Called party SSI information element contents**

Information element	Length	Value	Remark
Short Subscriber Identity (SSI)	24		See EN 300 392-1 [9], clause 7

## 14.8.9 Calling party type identifier

The calling party type identifier information element shall indicate the type of address which shall follow in the PDU as defined in table 97.



**Table 97: Calling party type identifier information element contents**

Information element	Length	Value	Remark
Calling Party Type Identifier	2	00 <sub>2</sub>	Reserved
		01 <sub>2</sub>	Short Subscriber Identity (SSI)
		10 <sub>2</sub>	TETRA Subscriber Identity (TSI)
		11 <sub>2</sub>	Reserved

### 14.8.10 Calling party extension

The calling party extension information element shall indicate the extended part of the TSI address of the calling user as defined in table 98.

**Table 98: Calling party extension information element contents**

Information sub-element	Length	Value	Remark
Country Code	10		See EN 300 392-1 [9] clause 7
Network Code	14		See EN 300 392-1 [9] clause 7

### 14.8.11 Calling party SSI

The Calling party SSI information element shall indicate the SSI address of the calling user as defined in table 99.

**Table 99: Calling party SSI information element contents**

Information element	Length	Value	Remark
Short Subscriber Identity (SSI)	24		See EN 300 392-1 [9] clause 7

### 14.8.12 Call priority

The call priority information element shall inform the SwMI or the MS/LS about the call priority as defined in table 100. The SS-PC and SS-PPC use this element, refer to EN 300 392-12-10 [43] and EN 300 392-12-16 [44].

**Table 100: Call priority information element contents**

Information element	Length	Value	Remark
Call priority	4	0000 <sub>2</sub>	Priority not defined
		0001 <sub>2</sub>	Priority 1 (Lowest Priority)
		0010 <sub>2</sub>	Priority 2
		...etc.	...etc.
		1011 <sub>2</sub>	Priority 11
		1100 <sub>2</sub>	Pre-emptive priority 1
		1101 <sub>2</sub>	Pre-emptive priority 2
		1110 <sub>2</sub>	Pre-emptive priority 3
1111 <sub>2</sub>	Pre-emptive priority 4 (Emergency)		

### 14.8.13 Call status

The call status information element shall inform the MS/LS about the status of the call as defined in table 101.

**Table 101: Call status information element contents**

Information element	Length	Value	Remark
Call status	3	000 <sub>2</sub>	Call is proceeding
		001 <sub>2</sub>	Call is queued
		010 <sub>2</sub>	Requested subscriber is paged
		011 <sub>2</sub>	Call continue
		100 <sub>2</sub>	Hang time expired
		101 <sub>2</sub>	Reserved
		110 <sub>2</sub>	Reserved
		111 <sub>2</sub>	Reserved

### 14.8.14 Call queued

The call queued information element shall inform the calling MS/LS that the call has been put in queue as defined in table 102.

**Table 102: Call queued information element contents**

Information element	Length	Value	Remark
Call queued	1	0	Call is not queued
		1	Call is queued

### 14.8.15 Continue

The continue information element shall inform the MS/LS if it shall continue after a pause in the same state as before the pause as defined in table 103.

**Table 103: Continue information element contents**

Information element	Length	Value	Remark
Continue	1	0	Not continue
		1	Continue

### 14.8.16 Call time-out

The call time-out information element shall set the maximum call time (T310) as defined in table 104.

**Table 104: Call time-out information element contents**

Information element	Length	Value	Remark
Call time-out	4	0000 <sub>2</sub>	Infinite Time
		0001 <sub>2</sub>	30 s
		0010 <sub>2</sub>	45 s
		0011 <sub>2</sub>	60 s
		0100 <sub>2</sub>	2 min
		0101 <sub>2</sub>	3 min
		0110 <sub>2</sub>	4 min
		0111 <sub>2</sub>	5 min
		1000 <sub>2</sub>	6 min
		1001 <sub>2</sub>	8 min
		1010 <sub>2</sub>	10 min
		1011 <sub>2</sub>	12 min
		1100 <sub>2</sub>	15 min
		1101 <sub>2</sub>	20 min
		1110 <sub>2</sub>	30 min
1111 <sub>2</sub>	Reserved		

### 14.8.17 Call time-out, set-up phase

The call time-out, set-up phase information element (T301 and T302) shall set the maximum set-up time valid for the call set-up phase as defined in table 105.

**Table 105: Call time-out, set-up phase information element contents**

Information element	Length	Value	Remark
Call time-out, set-up phase	3	000 <sub>2</sub>	Use predefined value, see note
		001 <sub>2</sub>	1 second
		010 <sub>2</sub>	2 s
		011 <sub>2</sub>	5 s
		100 <sub>2</sub>	10 s
		101 <sub>2</sub>	20 s
		110 <sub>2</sub>	30 s
		111 <sub>2</sub>	60 s

NOTE: This value shall indicate that the MS/LS shall use a predefined value for the timer.

### 14.8.17a Circuit mode type

The circuit mode type information element shall indicate the TCH type and the interleaving depth N as defined in table 105a (see clause 8).

**Table 105a: Circuit mode type information element contents**

Information element	Length	Value	Remark
Circuit mode type	3	000 <sub>2</sub>	Speech: TCH/S
		001 <sub>2</sub>	Unprotected: TCH/7,2
		010 <sub>2</sub>	Low Protection: TCH/4,8, N = 1
		011 <sub>2</sub>	Low Protection: TCH/4,8, N = 4
		100 <sub>2</sub>	Low Protection: TCH/4,8, N = 8
		101 <sub>2</sub>	High Protection: TCH/2,4, N = 1
		110 <sub>2</sub>	High Protection: TCH/2,4, N = 4
		111 <sub>2</sub>	High Protection: TCH/2,4, N = 8

### 14.8.17b CLIR control

The CLIR control information element shall define whether the calling user invokes or overrides calling user identity presentation restriction as defined in table 105b, refer to EN 300 392-12-1 [16].

**Table 105b: CLIR control information element contents**

Information element	Length	Value	Remark
CLIR control	2	00 <sub>2</sub>	Not implemented or use default mode
		01 <sub>2</sub>	Reserved
		10 <sub>2</sub>	Presentation not restricted
		11 <sub>2</sub>	Presentation restricted

### 14.8.17c Communication type

The communication type information element shall inform the other communication party which type of communication service is requested as defined in table 105c.

**Table 105c: Communication type information element contents**

Information sub-element	Length	Value	Remark
Communication type	2	00 <sub>2</sub>	Point-to-point
		01 <sub>2</sub>	Point-to-multipoint
		10 <sub>2</sub>	Point-to-multipoint Acknowledged
		11 <sub>2</sub>	Broadcast

## 14.8.18 Disconnect cause

The disconnect cause information element shall inform the MS/LS or the infrastructure of the reason for the release/disconnection as defined in table 106.

**Table 106: Disconnect cause information element contents**

Information element	Length	Value	Remark
Disconnect cause	5	00000 <sub>2</sub>	Cause not defined or unknown
		00001 <sub>2</sub>	User requested disconnect
		00010 <sub>2</sub>	Called party busy
		00011 <sub>2</sub>	Called party not reachable
		00100 <sub>2</sub>	Called party does not support encryption
		00101 <sub>2</sub>	Congestion in infrastructure
		00110 <sub>2</sub>	Not allowed traffic case
		00111 <sub>2</sub>	Incompatible traffic case
		01000 <sub>2</sub>	Requested service not available
		01001 <sub>2</sub>	Pre-emptive use of resource
		01010 <sub>2</sub>	Invalid call identifier
		01011 <sub>2</sub>	Call rejected by the called party
		01100 <sub>2</sub>	No idle CC entity
		01101 <sub>2</sub>	Expiry of timer
		01110 <sub>2</sub>	SwMI requested disconnection
		01111 <sub>2</sub>	Acknowledged service not completed
		10000 <sub>2</sub>	Unknown TETRA identity
		10001 <sub>2</sub>	SS-specific disconnection
		10010 <sub>2</sub>	Unknown external subscriber identity
		10011 <sub>2</sub>	Call restoration of the other user failed
		10100 <sub>2</sub>	Called party requires encryption
		10101 <sub>2</sub>	Concurrent set-up not supported
		10110 <sub>2</sub>	Called party is under the same DM-GATE of the calling party
10111 <sub>2</sub>	Reserved		
...etc.	...etc.		
11111 <sub>2</sub>	Reserved		

## 14.8.18a DM-MS address

For the definition of the DM-MS address information element refer to ETS 300 396-5 [14].

## 14.8.19 DTMF

The DTMF information element shall transfer DTMF digits (n digits where n shall be less than or equal to 254) to another user application as defined in table 107.

**Table 107: DTMF information element contents**

Information element	Length	Type	C/O/M	Remark
DTMF type	3	1	M	
DTMF digit	4		C	see notes 1 and 2
NOTE 1: Shall be conditional on the value of DTMF type: - DTMF type = 000 <sub>2</sub> (DTMF tone start); DTMF digit(s) present; - DTMF type = any other value; DTMF digit information element not present.				
NOTE 2: This element, if present, shall be repeated for each digit in the DTMF number. The number of DTMF digits in the DTMF number information element is: (the length of the DTMF information element - 3)/4.				

### 14.8.19a DTMF digit

The DTMF digit information element shall define the numerical values for DTMF digits as defined in table 107a.

**Table 107a: DTMF digit information element contents**

Information element	Length	Value	Remark
DTMF digit	4	0000 <sub>2</sub>	Digit "0"
		0001 <sub>2</sub>	Digit "1"
		0010 <sub>2</sub>	Digit "2"
		0011 <sub>2</sub>	Digit "3"
		0100 <sub>2</sub>	Digit "4"
		0101 <sub>2</sub>	Digit "5"
		0110 <sub>2</sub>	Digit "6"
		0111 <sub>2</sub>	Digit "7"
		1000 <sub>2</sub>	Digit "8"
		1001 <sub>2</sub>	Digit "9"
		1010 <sub>2</sub>	Digit "*"
		1011 <sub>2</sub>	Digit "#"
		1100 <sub>2</sub>	Digit "A"
		1101 <sub>2</sub>	Digit "B"
		1110 <sub>2</sub>	Digit "C"
1111 <sub>2</sub>	Digit "D"		

### 14.8.19b DTMF type

The DTMF type information element shall define DTMF tone characteristics as defined in table 107b.

NOTE: The length of this information element is chosen so that a receiving application can differentiate between the DTMF signalling mechanisms used in edition 1 and this version of the present document based on the total length of the DTMF information element (length is exactly divisible by 4 for the edition 1 mechanism and not exactly divisible by 4 for this version).

**Table 107b: DTMF type information element contents**

Information element	Length	Value	Remark
DTMF type	3	000 <sub>2</sub>	DTMF tone start
		001 <sub>2</sub>	DTMF tone end
		010 <sub>2</sub>	DTMF not supported
		011 <sub>2</sub>	DTMF not subscribed
		100 <sub>2</sub>	Reserved
		...etc.	...etc.
		111 <sub>2</sub>	Reserved

## 14.8.20 External subscriber number

The external subscriber number information element shall transfer a subscriber number from a TETRA subscriber to a gateway or from a gateway to a TETRA subscriber as defined in table 108. The external subscriber number can consist of n digits where n shall be less than or equal to 24. The number of digits is indicated by the preceding type 3 element length divided by four.

The digits of the external subscriber number shall be in descending order (as normally dialled in man machine interface) in the information element. Each digit in the external subscriber number information element shall be encoded as defined in table 108.

**Table 108: Encoding of the digits in the external subscriber number information element**

Information element	Length	Value	Remark
External subscriber number digit	4	0000 <sub>2</sub>	Digit "0"
		0001 <sub>2</sub>	Digit "1"
		0010 <sub>2</sub>	Digit "2"
		0011 <sub>2</sub>	Digit "3"
		0100 <sub>2</sub>	Digit "4"
		0101 <sub>2</sub>	Digit "5"
		0110 <sub>2</sub>	Digit "6"
		0111 <sub>2</sub>	Digit "7"
		1000 <sub>2</sub>	Digit "8"
		1001 <sub>2</sub>	Digit "9"
		1010 <sub>2</sub>	Digit "*"
		1011 <sub>2</sub>	Digit "#"
		1100 <sub>2</sub>	Digit "+"
		1101 <sub>2</sub>	Reserved
		1110 <sub>2</sub>	Reserved
1111 <sub>2</sub>	Reserved		

## 14.8.21 Encryption control

The encryption control information element shall enable an MS/LS to request for encryption/clear mode and then be informed about the granting result of this request as defined in table 109.

**Table 109: Encryption control information element contents**

Information element	Length	Value	Remark
Encryption control	1	0	Clear
		1	End-to-end encrypted

## 14.8.21a Encryption flag

The encryption flag information element shall indicate whether the circuit mode speech or data is end-to-end encrypted as defined in table 109a.

**Table 109a: Encryption flag information element contents**

Information sub-element	Length	Value	Remark
Encryption flag	1	0	Clear Mode
		1	TETRA end-to-end encryption

### 14.8.22 Facility

The facility information element shall be an optional variable length element and shall be used to send and receive SS information appended to the PDUs which can carry the facility element.

The size and the structure of the facility information element shall be dependent on each individual SS and shall be further detailed in the SS protocol clauses, refer to EN/ETS 300 392-12 [13].

There can be multiple facility information elements in the same PDU although a single facility information element can carry multiple supplementary services, refer to EN 300 392-9 [12].

### 14.8.23 Hook method selection

The hook method selection information element shall inform the infrastructure and the called user(s) of the preferred hook method as defined in table 110.

**Table 110: Hook method selection information element contents**

Information element	Length	Value	Remark
Hook method selection	1	0	No hook signalling (direct through-connect)
		1	Hook on/Hook off signalling

### 14.8.24 Length indicator

The length Indicator information element shall define the length of the user defined data-4 as defined in table 111.

**Table 111: Length indicator information element contents**

Information element	Length	Value	Remark
Length indicator	11	0	0 bits
		1	1 bit
		...etc.	...etc.
		( $2^{11}-1$ )	2 047 bits

### 14.8.25 New call identifier

The new call identifier information element coding shall be the same as for the call identifier element.

### 14.8.26 Modify

The modify information element shall change an ongoing call either to a new basic service or the behaviour from simplex to duplex or reverse as defined in table 112.

**Table 112: Modify information element contents**

Information sub-element	Length	Value	Remark
Simplex/duplex selection	1		See description of "Simplex/duplex selection" element
Basic service information	8		See description of "Basic service information" element



## 14.8.27 Notification indicator

The notification indicator information element shall be used in SSs by the SwMI to inform a MS/LS of various events as defined in table 113.

**Table 113: Notification indicator information element contents**

Information element	Length	Value	Remark
Notification indicator	6	0 to 63 <sub>10</sub>	Refer to EN 300 392-9 [12] clause 7.2.2

### 14.8.27a Other party type identifier

The other party type identifier information element coding shall be the same as for the called party type identifier element, refer to clause 14.8.5.

### 14.8.27b Other party SNA

The other party SNA information element coding shall be the same as for the called party SNA element, refer to clause 14.8.6.

### 14.8.27c Other party extension

The other party extension information element coding shall be the same as for the called party extension element, refer to clause 14.8.7.

### 14.8.27d Other party SSI

The other party SSI information element coding shall be the same as for the called party SSI element, refer to clause 14.8.8.

### 14.8.28 PDU type

The PDU type information element shall identify the type of CMCE PDU sent over the air interface. The PDU type information element shall have separate definitions in the uplink and downlink directions as defined in table 114.

**Table 114: PDU type information element contents**

Information element	Length	Value	Remark	
			Downlink	Uplink
PDU Type	5	00000 <sub>2</sub>	D-ALERT	U-ALERT
		00001 <sub>2</sub>	D-CALL-PROCEEDING	Reserved
		00010 <sub>2</sub>	D-CONNECT	U-CONNECT
		00011 <sub>2</sub>	D-CONNECT ACKNOWLEDGE	Reserved
		00100 <sub>2</sub>	D-DISCONNECT	U-DISCONNECT
		00101 <sub>2</sub>	D-INFO	U-INFO
		00110 <sub>2</sub>	D-RELEASE	U-RELEASE
		00111 <sub>2</sub>	D-SETUP	U-SETUP
		01000 <sub>2</sub>	D-STATUS	U-STATUS
		01001 <sub>2</sub>	D-TX CEASED	U-TX CEASED
		01010 <sub>2</sub>	D-TX CONTINUE	U-TX DEMAND
		01011 <sub>2</sub>	D-TX GRANTED	Reserved
		01100 <sub>2</sub>	D-TX WAIT	Reserved
		01101 <sub>2</sub>	D-TX INTERRUPT	Reserved
		01110 <sub>2</sub>	D-CALL-RESTORE	U-CALL-RESTORE
		01111 <sub>2</sub>	D-SDS-DATA	U-SDS-DATA
		10000 <sub>2</sub>	D-FACILITY	U-FACILITY
		10001 <sub>2</sub>	Reserved	Reserved
		10010 <sub>2</sub>	Reserved	Reserved
		...etc.	...etc.	...etc.
11111 <sub>2</sub>	CMCE FUNCTION NOT SUPPORTED	CMCE FUNCTION NOT SUPPORTED		

### 14.8.29 Poll request

This poll request information element shall be used by the SwMI to request a poll response back from the MS/LS when an acknowledged group call has been initiated as defined in table 115.

**Table 115: Poll request information element contents**

Information element	Length	Value	Remark
Poll request	1	0	No poll answer requested
		1	Poll answer requested

### 14.8.30 Poll response

This poll response information element shall be used by the MS/LS to respond to a poll request in an acknowledged group call from the SwMI as defined in table 116.

**Table 116: Poll response information element contents**

Information element	Length	Value	Remark
Poll response	1	0	No poll response
		1	Poll response

### 14.8.31 Poll response addresses

The poll response addresses information element shall provide the addresses on responding group members in an acknowledged group call as defined in table 117.

**Table 117: Poll response addresses information element contents**

Information element	Length	Value	Remark
1st TSI address	48		See EN 300 392-1 [9], clause 7
2nd TSI address	48		
...etc.	...etc.		
nth TSI address	48		

### 14.8.32 Poll response number

The poll response number information element shall provide the number of responding group members in an acknowledged group call as defined in table 118.

**Table 118: Poll response number information element contents**

Information element	Length	Value	Remark
Number of responding group members	6	0 to 63 <sub>10</sub>	

### 14.8.33 Poll response percentage

The poll response percentage information element shall provide the percentage of responding group members in an acknowledged group call as defined in table 119.

**Table 119: Poll response percentage information element contents**

Information element	Length	Value	Remark
Percentage of responding number of group members	6	0	0 %
		1	2 %
		...etc.	...etc.
		50 <sub>10</sub>	100 %
		51 <sub>10</sub>	Reserved
		...etc.	...etc.
		63 <sub>10</sub>	Reserved

### 14.8.34 Pre-coded status

The pre-coded status information element shall define general purpose status messages known to all TETRA systems as defined in table 120 and shall provide support for the SDS-TL "short reporting" protocol.

**Table 120: Pre-coded status information element contents**

Information element	Length	Value	Remark
Pre-coded status	16	0	Emergency
		1	Reserved
		...etc.	...etc.
		31 743 <sub>10</sub>	Reserved
		31 744 <sub>10</sub>	Refer to SDS-TL in clause 29
		...etc.	...etc.
		32 767 <sub>10</sub>	Refer to SDS-TL in clause 29
		32 768 <sub>10</sub>	Available for TETRA network and user specific definitions
		...etc.	...etc.
		65 535 <sub>10</sub>	Available for TETRA network and user specific definitions

### 14.8.35 Proprietary

Proprietary is an optional, variable length information element and shall be used to send and receive proprietary defined information appended to the PDUs as defined in table 120a. The proprietary element is terminated in CMCE.

The use, the size and the structure of the proprietary element is outside the scope of the present document.

**Table 120a: Proprietary information element contents**

Information element	Length	Value	Remark
Proprietary element owner	8	Varies	Refer to annex H
Proprietary information	varies	Varies	Contents is outside the scope of the present document

### 14.8.36 Request to transmit/send data

The request to transmit/send data information element shall inform the infrastructure about immediate request to transmit or data transmission at through-connection as defined in table 121.

**Table 121: Request to transmit/send data information element contents**

Information element	Length	Value	Remark
Request to transmit/send data	1	0	Request to transmit/send data
		1	Request that other MS/LS may transmit/send data

### 14.8.37 Reset call time-out timer (T310)

The reset call time-out timer information element shall reset and start the overall call length timer T310 in the MS/LS as defined in table 122.

**Table 122: Reset call time-out timer information element contents**

Information element	Length	Value	Remark
Reset call time-out value	1	0	No reset of call time-out timer T310
		1	Reset call time-out timer T310

### 14.8.38 Short data type identifier

The short data type identifier information element shall identify the length of the user defined data sent to or received from the SwMI as defined in table 123.

**Table 123: Short data type identifier information element contents**

Information element	Length	Value	Remark
Short data type identifier	2	00 <sub>2</sub>	User Defined Data 1 element is 16 bits long
		01 <sub>2</sub>	User Defined Data 2 element is 32 bits long
		10 <sub>2</sub>	User Defined Data 3 element is 64 bits long
		11 <sub>2</sub>	User Defined Data 4 element is 0 to 2 047 bits long (variable length)

### 14.8.39 Simplex/duplex selection

The simplex/duplex selection information element shall be to inform the infrastructure the preferred mode of operation as defined in table 124.

**Table 124: Simplex/duplex selection information element contents**

Information element	Length	Value	Remark
Simplex/duplex selection	1	0	Simplex requested
		1	Duplex requested

### 14.8.39a Slots per frame

The slots per frame information element shall indicate the required bit rate for a circuit mode data call as defined in table 124a. For TCH/7,2, TCH/4,8 and TCH/2,4 the resulting bit rate is the TCH bit rate multiplied by the number of slots per frame. (e.g. TCH/7,2 in four time slots per frame gives a circuit mode data rate of 28,8 kbit/s).

**Table 124a: Slots per frame information element contents**

Information sub-element	Length	Value	Remark
Slots per frame	2	00 <sub>2</sub>	One slot
		01 <sub>2</sub>	Two slots
		10 <sub>2</sub>	Three slots
		11 <sub>2</sub>	Four slots

### 14.8.40 Speech service

The speech service information element shall indicate the required speech and channel encoding as defined in table 125.

**Table 125: Speech service information element contents**

Information element	Length	Value	Remark
Speech service	2	00 <sub>2</sub>	TETRA encoded speech
		01 <sub>2</sub>	Reserved
		10 <sub>2</sub>	Reserved
		11 <sub>2</sub>	Proprietary encoded speech

### 14.8.41 Temporary address

The temporary address information element coding shall be the same as for the SSI element.

### 14.8.42 Transmission grant

The transmission grant information element shall inform the MS/LS about permission to transmit as defined in table 126.

**Table 126: Transmission grant information element contents**

Information element	Length	Value	Remark
Transmission grant	2	00 <sub>2</sub>	Transmission granted
		01 <sub>2</sub>	Transmission not granted
		10 <sub>2</sub>	Transmission request queued
		11 <sub>2</sub>	Transmission granted to another user

### 14.8.43 Transmission request permission

The transmission request permission information element shall inform the MS/LS if it is allowed to request for transmit permission as defined in table 127.

**Table 127: Transmission request permission information element contents**

Information element	Length	Value	Remark
Transmission request permission	1	0	Allowed to request for transmission
		1	Not allowed to request for transmission

### 14.8.44 Transmitting party type identifier

The transmitting party type identifier information element coding shall indicate the type of address which shall follow in the PDU as defined in table 128.

**Table 128: Transmitting party type identifier information element contents**

Information element	Length	Value	Remark
Transmitting party type identifier	2	00 <sub>2</sub>	Reserved
		01 <sub>2</sub>	Short Subscriber Identity (SSI)
		10 <sub>2</sub>	TETRA Subscriber Identity (TSI)
		11 <sub>2</sub>	Reserved

### 14.8.45 Transmitting party extension

The transmitting party extension information element shall indicate the extended part of the TSI address of the transmitting user as defined in table 129.

**Table 129: Transmitting party extension information element contents**

Information sub-element	Length	Value	Remark
Country Code	10		See EN 300 392-1 [9], clause 7
Network Code	14		See EN 300 392-1 [9], clause 7

### 14.8.46 Transmitting party SSI

The transmitting party SSI information element shall indicate the SSI address of the transmitting user as defined in table 130.

**Table 130: Transmitting party SSI information element contents**

Information element	Length	Value	Remark
Short Subscriber Identity (SSI)	24		See EN 300 392-1 [9], clause 7

### 14.8.47 TX demand priority

The TX demand priority information element shall inform the SwMI about the importance of a TX-Demand as defined in table 131.

**Table 131: Tx demand priority information element contents**

Information element	Length	Value	Remark
TX demand priority	2	00 <sub>2</sub>	Low priority level
		01 <sub>2</sub>	High priority level
		10 <sub>2</sub>	Pre-emptive priority level
		11 <sub>2</sub>	Emergency pre-emptive priority level

### 14.8.48 Type 3 element identifier

The type 3 element identifier information element shall indicate the type of the following type 3 element in the PDU as defined in table 132.

**Table 132: Type 3 element identifier information element contents**

Information element	Length	Value	Remark
Type 3 element identifier	4	0000 <sub>2</sub>	Reserved
		0001 <sub>2</sub>	DTMF
		0010 <sub>2</sub>	External subscriber number
		0011 <sub>2</sub>	Facility
		0100 <sub>2</sub>	Poll response addresses
		0101 <sub>2</sub>	Temporary address
		0110 <sub>2</sub>	DM-MS address
		0111 <sub>2</sub>	Reserved for any future specified Type 3 element
		...etc.	...etc.
		1111 <sub>2</sub>	Proprietary

### 14.8.49 User defined data-1

The User Defined Data-1 information element shall enable the user applications to determine their own interpretation of the SDS message as defined in table 133.

**Table 133: User Defined Data-1 information element contents**

Information element	Length	Value	Remark
User Defined Data-1	16	0 to (2 <sup>16</sup> - 1)	All values available for the user application

### 14.8.50 User defined data-2

The User Defined Data-2 information element shall enable the user applications to determine their own interpretation of the SDS message as defined in table 134.

**Table 134: User Defined Data-2 information element contents**

Information element	Length	Value	Remark
User Defined Data-2	32	0 to $(2^{32} - 1)$	All values available for the user application

### 14.8.51 User defined data-3

The User Defined Data-3 information element shall enable the user applications to determine their own interpretation of the SDS message as defined in table 135.

**Table 135: User Defined Data-3 information element contents**

Information element	Length	Value	Remark
User Defined Data-3	64	0 to $(2^{64} - 1)$	All values available for the user application

### 14.8.52 User defined data-4

The User Defined Data-4 information element shall enable the user applications to determine their own interpretation of the SDS message as defined in table 136. The first 8 bits of the user defined data-4 element shall contain a protocol identifier as defined in clause 29.

**Table 136: User Defined Data-4 information element contents**

Information element	Length	Value	Remark
Protocol identifier	8	varies	Refer to clause 29
Protocol dependent User Defined Data-4	varies (0 to 2 039 bits)	varies	Refer to clause 29

---

## 15 Mobility Management (MM) service description

### 15.1 Introduction

This clause describes the services offered by the MM entity (see EN 300 392-1 [9], clause 6) for the V+D TETRA layer 3 air interface. The MM SAP is used in conformance testing as a normative boundary in TETRA MSs and in TETRA LSs.

### 15.2 Services offered

The MM shall be a service provider for mobility service users on the layer 3 MS air interface. The services shall be made available through a TETRA Network Mobility Management Service Access Point (TNMM-SAP) (see EN 300 392-1 [9], clause 6) which is shown in figure 41. The protocol description is defined in clause 16.

The services offered by MM are:

- registration (mandatory), this service shall allow a user to register manually to the network, the user shall be then informed of the result of the registration. When a MS roams or migrates the user application shall be also informed that the MS is ready for use or that registration was not possible (see EN 300 392-1 [9], clause 9);



- de-registration (detach) (optional), this service allows a user to request cancellation of the registration;
- change of energy saving mode (optional), this service shall allow the user to ask for changing the energy saving mode with confirmation or to receive and to respond to an energy saving mode allocation;
- change of dual watch mode (optional), this service allows the user to ask for dual watch operation with an appropriate energy economy group or to end dual watch operation;
- attachment/detachment of group identities (optional), this service shall allow the user application to either activate or deactivate already defined group identities in the MS/LS. The service shall also inform the user applications of the result of the attachment/detachment of the group identities both when the user application initiates the attachment/detachment or when the SwMI initiates the attachment/detachment;
- information concerning state of the mobile (optional).

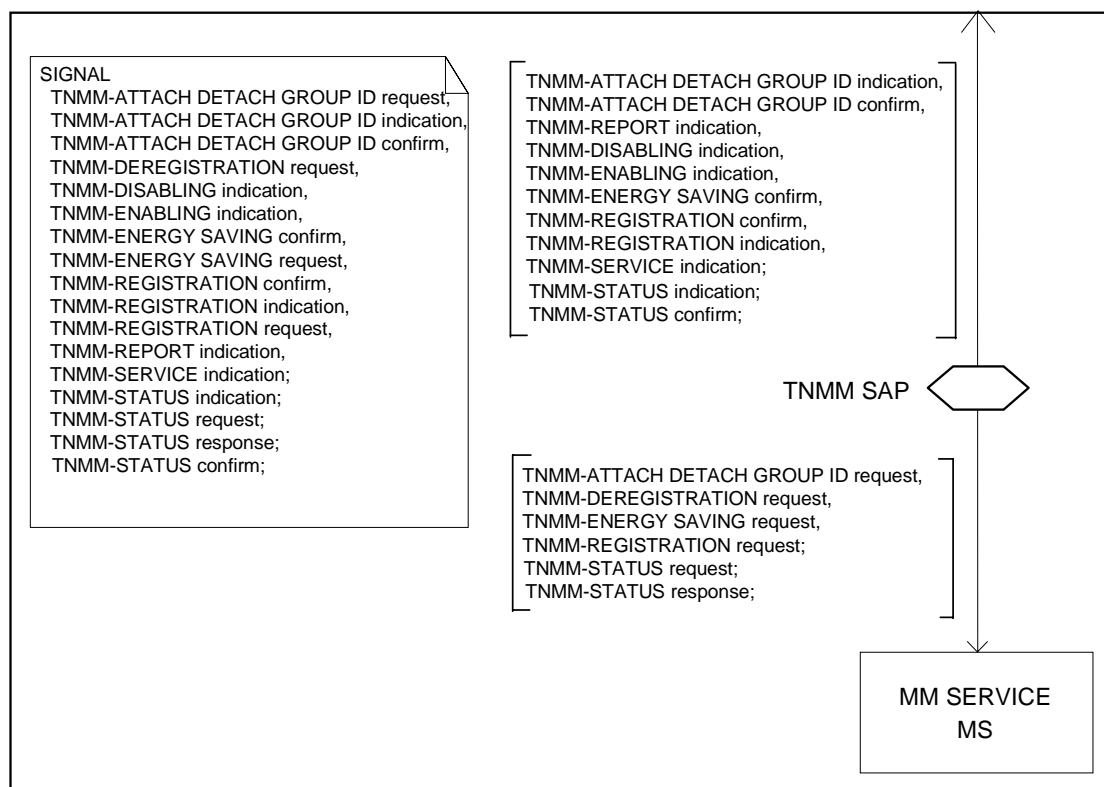
NOTE: Enable, disable service is defined in EN 300 392-7 [11], this service allows a user to be aware of the temporary or permanent disabling asked by the network. The user application is also made aware of the cessation of a temporary disable.

## 15.3 Primitive description

The services shall be provided through primitives at the TNMM-SAP. This clause describes the primitives and their parameters.

### 15.3.1 Service state model for the MS

The primitives provided at the TNMM-SAP are illustrated in figure 41.



NOTE: TNMM-DISABLING and TNMM-ENABLING primitives are defined in EN 300 392-7 [11].

Figure 41: Services provided at TNMM-SAP/MS-side

## 15.3.2 Service primitives at the TNMM-SAP, MS/LS side

The set of MM primitives that are available to provide the specified service to the user application shall be:

- TNMM-ATTACH DETACH GROUP IDENTITY request/indication/confirm: the primitives shall be used to handle activation and deactivation of defined GTSIs in the MS/LS or to request group report from SwMI;
- TNMM-DEREGISTRATION request: the primitive shall be used to handle detachment of attached ITSIs;
- TNMM-ENERGY SAVING indication /request/confirm: the primitives shall be used to exchange energy saving mode of operation to the SwMI;
- TNMM-REGISTRATION request/indication/confirm: the primitives shall be used to handle attachment of ITSIs and can as well be used for activation/de-activation of GSSIs;
- TNMM-REPORT indication: the primitive shall be used to inform the user application of a successful or unsuccessful transmission of U-ITSI DETACH;
- TNMM-SERVICE indication: the primitive shall be used as an indication to the user application to reflect the service state of the MS, i.e. whether it shall be possible to initiate or receive communication using the current network;
- TNMM-STATUS request/indication/response/confirm: the primitives shall be used for various mobility management services.

## 15.3.3 Primitive description

The information contained in the primitive description tables which follow corresponds to the following key:

- M: Mandatory;
- C: Conditional;
- O: Optional;
- -: Not used.

### 15.3.3.1 TNMM-ATTACH DETACH GROUP IDENTITY primitive

TNMM-ATTACH DETACH GROUP IDENTITY request primitive shall be used by the user application to activate or deactivate one or more defined group identities in the MS/LS or ask for group report.

TNMM-ATTACH DETACH GROUP IDENTITY indication primitive shall be used as an indication to the user application when the SwMI has activated or de-activated one or more defined group identities in the MS/LS.

TNMM-ATTACH DETACH GROUP IDENTITY confirm primitive shall be used as an indication to the user, that the requested activation or de-activation of group identities is negotiated between the MS/LS and the SwMI.

The parameters shall be as defined in table 137.

**Table 137: Parameters for the primitive TNMM-ATTACH DETACH GROUP IDENTITY**

Parameter	Request	Indication	Confirm
Group identity attach detach mode	M	-	M
Group identity request	M	-	-
Group identity report	O	-	O
Group identities	-	M	M

### 15.3.3.2 TNMM-DEREGISTRATION primitive

TNMM-DEREGISTRATION request: shall be used to request to cancel the registration, stimulated either by removing the "ITSI identity" or a "log-off" application or automatically in the power off phase.

The parameters shall be as defined in table 138.

**Table 138: Parameters for the primitive TNMM-DEREGISTRATION**

Parameter	Request
ISSI	○
MCC	○
MNC	○
NOTE: In case all the attached ITSIs are detached, the parameters need not to be present.	

### 15.3.3.3 TNMM-DISABLING primitive

Refer to EN 300 392-7 [11], clause 5.

**Table 139: Parameters for the primitive TNMM-DISABLING (Void)**

### 15.3.3.4 TNMM-ENABLING primitive

Refer to EN 300 392-7 [11], clause 5.

**Table 140: Parameters for the primitive TNMM-ENABLING (Void)**

### 15.3.3.5 TNMM-ENERGY SAVING primitive

NOTE: This primitive is present at the TNMM-SAP in a LS but need not be used since a LS is normally not battery powered.

TNMM-ENERGY SAVING indication primitive shall be used to indicate to the user application a start or change of energy economy mode the SwMI wants to use.

TNMM-ENERGY SAVING request primitive shall be used by the user application to change or re-state to the SwMI what energy economy mode the MS wants to use.

TNMM-ENERGY SAVING confirm primitive shall be used as a confirmation to the user application that the changed or re-stated energy economy mode has been reported to the SwMI.

The parameters shall be as defined in table 141.

**Table 141: Parameters for the primitive TNMM-ENERGY SAVING**

Parameter	Request	Confirm	Indication
Energy economy mode	M	M	○
Energy economy mode status	-	M	○

### 15.3.3.6 TNMM-REPORT primitive

TNMM-REPORT indication shall be used to inform the user application of a successful or unsuccessful transmission of U-ITSI DETACH.

The parameters shall be as defined in table 142.

**Table 142: Parameters for the TNMM-REPORT primitive**

Parameter	Indication
Transfer result	M

### 15.3.3.7 TNMM-REGISTRATION primitive

TNMM-REGISTRATION request primitive shall be used by the user application to initiate attachment and registration of the terminal.

TNMM-REGISTRATION indication primitive shall be used as an indication to the user application that the LS/MS has carried out registration procedure (either successfully or unsuccessfully) or that LA registration is expired.

TNMM-REGISTRATION confirm primitive shall be used to inform the user application that registration is confirmed. The primitive may be used to inform the user that the MS/LS is ready for use.

The parameters shall be as defined in table 143.

**Table 143: Parameters for the primitive TNMM-REGISTRATION**

Parameter	Request	Indication	Confirm
Registration status	-	M	M
Registration reject cause (see note 1)	-	C	C
LA (where registered)	-	M	M
MCC (where registered)	-	M	M
MNC (where registered)	-	M	M
Registration type	M	-	-
Preferred LA list (see note 2)	O	-	-
Preferred MCC list (see note 3)	O	-	-
Preferred MNC list (see note 3)	O	-	-
ISSI	M	-	-
MCC (of the ISSI)	M	-	-
MNC (of the ISSI)	M	-	-
Energy economy mode	O	O	O
Energy economy mode status	-	O	O
Group identities	-	O	O
Group identity request	O	-	-
Group identity attach/detach mode	O	O	O
NOTE 1: Shall be present if Registration Status = "failure".			
NOTE 2: Shall be present if Registration Type = "No new ITSI - forward registration".			
NOTE 3: Shall be present if Registration Type = "New ITSI"; or Registration Type = "No new ITSI - forward registration".			
NOTE 4: Shall be used when the registration status indicates "LA registration is expired".			

### 15.3.3.8 TNMM-SERVICE primitive

TNMM-SERVICE indication primitive shall be used as an indication to the user application to reflect the service state of the MS, i.e. whether it shall be possible to initiate or receive communication using the current network.

The parameters shall be as defined in table 144.

**Table 144: Parameters for the primitive TNMM-SERVICE**

Parameter	Indication
Service status	M
Disable status	M

### 15.3.3.9 TNMM-STATUS primitive

TNMM-STATUS request primitive shall be used to request various mobility management services.

TNMM-STATUS indication primitive shall indicate to the user application a mobility management service or action request.

TNMM-STATUS confirm primitive shall indicate to the user application the result of a request.

The parameters shall be as defined in table 144a.

NOTE: The energy economy mode is also managed by this primitive.

**Table 144a: Parameters for the primitive TNMM-STATUS**

Parameter	Request	Indication	Confirm
Service status		M	
Disable status		M	
Direct mode	O	-	-
Dual watch	O	O	O
Energy economy mode, see note	O	O	O
NOTE: This parameter is applicable with the dual watch parameter.			

## 15.3.4 Parameters description

Parameters shall be part of the primitives described in clause 15.3.3 and if applied the parameters shall contain the values specified in this clause.

- Class of usage =
  - Class of Usage 1;
  - Class of Usage 2;
  - Class of Usage 3;
  - Class of Usage 4;
  - Class of Usage 5;
  - Class of Usage 6;
  - Class of Usage 7;
  - Class of Usage 8.

- Disable status =
  - enabled;
  - temporary disabled;
  - permanently disabled.
- Dual watch =
  - starting dual watch mode;
  - modify or resume dual watch mode;
  - dual watch mode accepted;
  - dual watch mode rejected;
  - dual watch mode not supported;
  - terminating dual watch mode;
  - terminating dual watch mode response;
  - dual watch energy economy group changed by SwMI;
  - dual watch mode terminated by SwMI.
- Direct mode =
  - start of direct mode operation.

NOTE: A return to trunking mode is a normal registration.

- Energy economy mode =
  - stay alive;
  - energy economy mode 1;
  - energy economy mode 2;
  - energy economy mode 3;
  - energy economy mode 4;
  - energy economy mode 5;
  - energy economy mode 6;
  - energy economy mode 7.
- Energy economy mode status =
  - accepted;
  - rejected.
- Group identities =

**Table 145: Group identities parameter**

Parameter	C/O/M	Remark
GTSI	M	
Group Identity Attach/detach Type Identifier	M	
Group Identity Lifetime	C	see note
Class of Usage	C	see note
Group Identity Detachment Reason	C	see note
NOTE: Shall be conditional on the value of Group Identity Type Identifier (GITI). - GITI = Attachment; Group Identity Lifetime + Class of Usage; - GITI = Detachment; Group Identity Detachment Reason.		

- Group identity attach/detach mode =
  - amendment;
  - detach the currently active group identities.
- Group identity request =

**Table 146: Group identity request parameter**

Parameter	C/O/M	Remark
GTSI	M	
Group Identity Attach/detach Type Identifier	M	
Class of Usage	C	see note
Group Identity Detachment Request	C	see note
NOTE: Shall be conditional on the value of Group Identity Type Identifier (GITI). - GITI = Attachment; Class of Usage; - GITI = Detachment; Group Identity Detachment.		

- Group identity Attach/detach type identifier =
  - attachment;
  - detachment.
- Group identity lifetime =
  - permanent, attachment not needed;
  - attachment needed for next ITSI-Attach;
  - attachment not allowed after next ITSI-Attach;
  - attachment needed for next location update.
- Group identity detachment =
  - permanently detached;
  - temporary 1 detached;
  - temporary 2 detached;
  - unknown group identity.
- Group identity detachment request =
  - user initiated detachment.
- Group identity report =
  - report requested;

- report not requested.
- GTSI =
  - Group TETRA Subscriber Identity.
- ISSI =
  - Individual Short Subscriber Identity.
- LA =
  - location area.
- MCC =
  - Mobile Country Code (see EN 300 392-1 [9], clause 7).
- MNC =
  - MNC (see EN 300 392-1 [9], clause 7).
- Preferred LA list =
  - list of LA identities.
- Preferred MCC list =
  - list of MCC identities.
- Preferred MNC list =
  - list of MNC identities.
- Registration reject cause =
  - ITSI unknown;
  - illegal MS;
  - LA not allowed;
  - LA unknown;
  - network failure;
  - congestion;
  - forward registration failure;
  - service not subscribed;
  - mandatory element error;
  - message consistency error;
  - roaming not supported;
  - migration not supported;
  - no cipher KSG;
  - identified cipher KSG not supported;
  - requested cipher key type not available;
  - identified cipher key not available;



- ciphering required;
- authentication failure.
- Registration status =
  - success;
  - failure;
  - LA registration expired;
  - no preferred cell found.
- Registration type =
  - periodic registration;
  - registration to indicated cell.
- Service status =
  - in service;
  - in service waiting for registration;
  - out of service;
  - MM busy;
  - MM idle.
- Transfer result =
  - transfer successful done;
  - transfer fail.

### 15.3.5 State description for the MS

The following clauses define the status of the different states used within the SDL description given in clause 15.3.6.

#### 15.3.5.1 Not updated

This state shall be used when the MS is ready for a registration request.

#### 15.3.5.2 Wait updating

This shall be an intermediate state while the network is processing the registration request.

#### 15.3.5.3 Updated

This shall be the state that is used while registered. The MS shall be ready for transactions.

#### 15.3.5.4 Temporary disabled

This state shall be used after receiving a <disable> message with parameter "temporary". The only way out of the state shall be a <enable> message.

#### 15.3.5.5 Permanently disabled

This state shall be used after receiving a <disable> message with parameter "permanently". There shall be no way out of the state using the air interface protocol as defined in the present document.

### 15.3.6 Service state diagram for the TNMM-SAP

The service state diagram for the TNMM-SAP shall be as shown in figure 42.

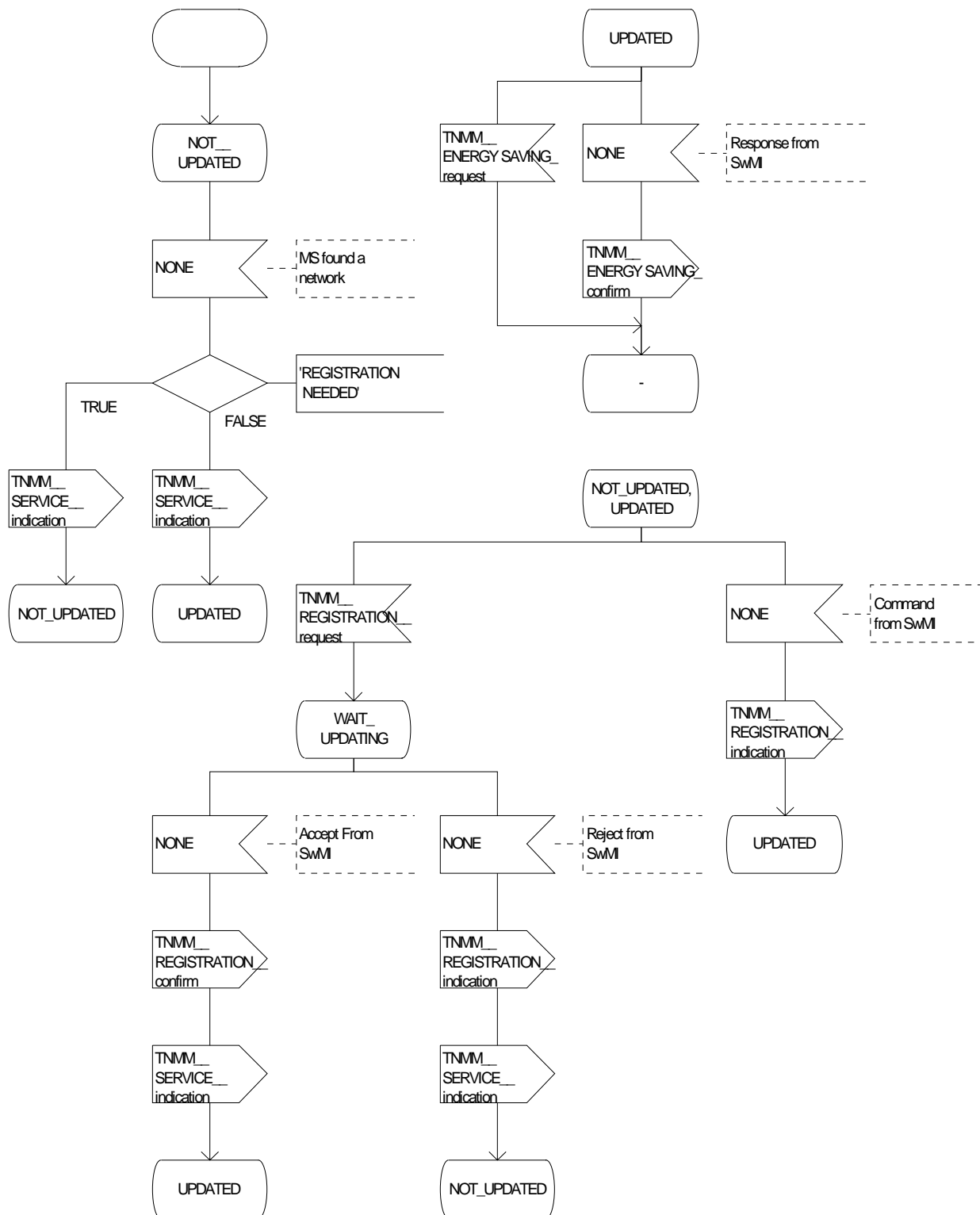


Figure 42: MM service state diagram (sheet 1 of 4)

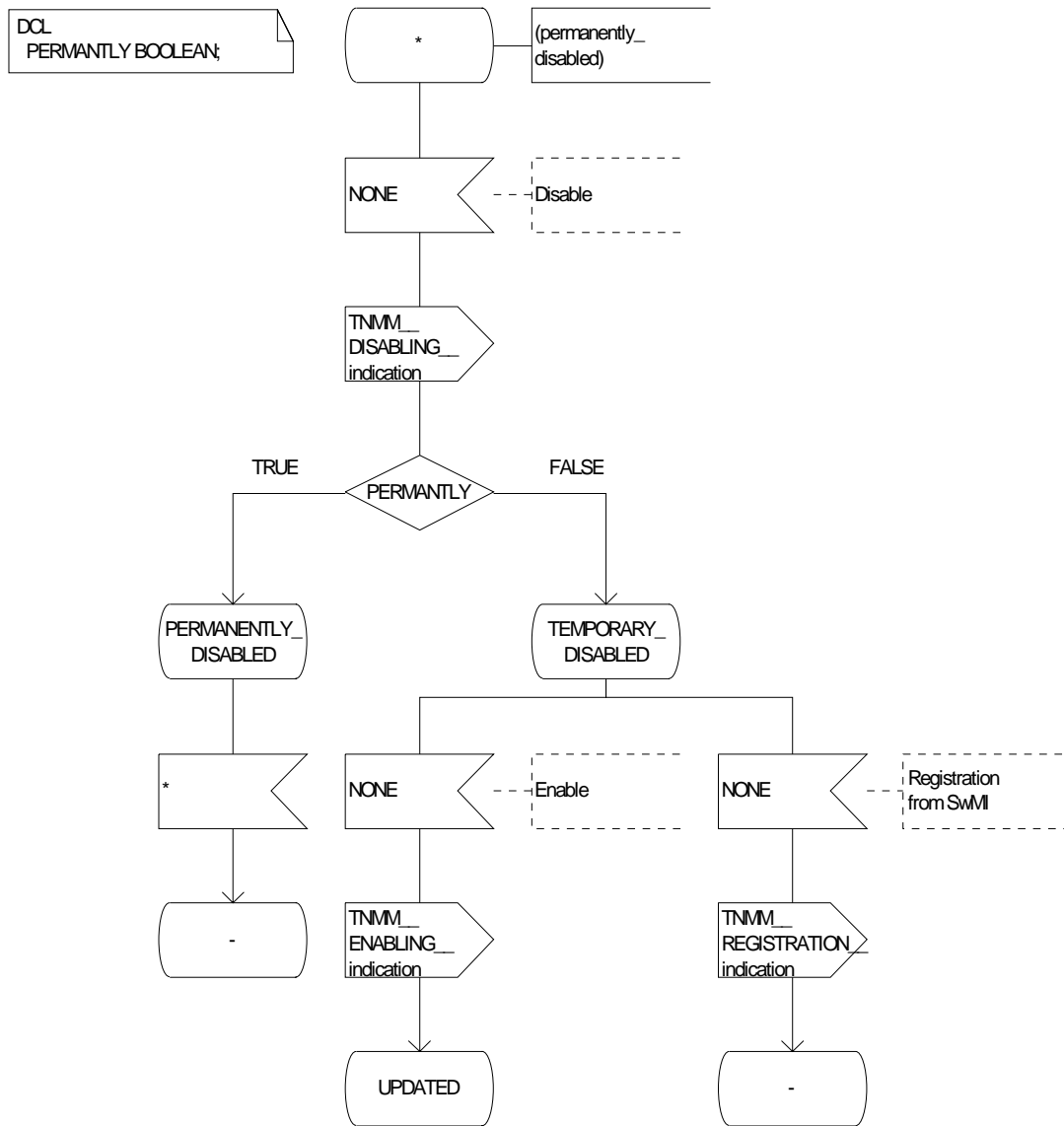


Figure 42: MM service state diagram (sheet 2 of 4)

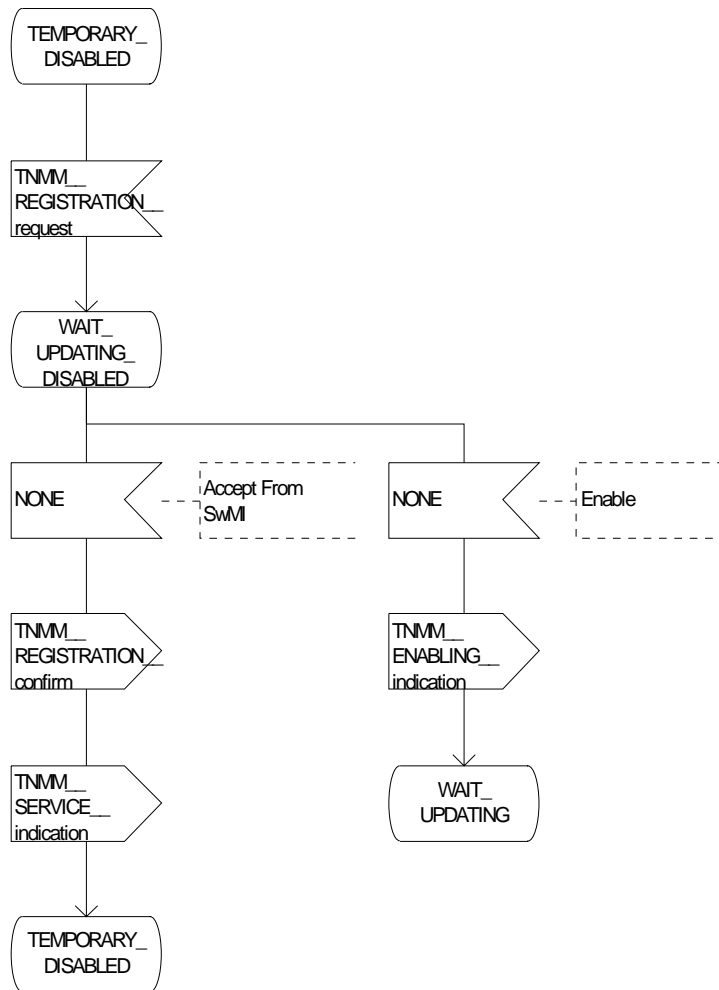


Figure 42: MM service state diagram (sheet 3 of 4)

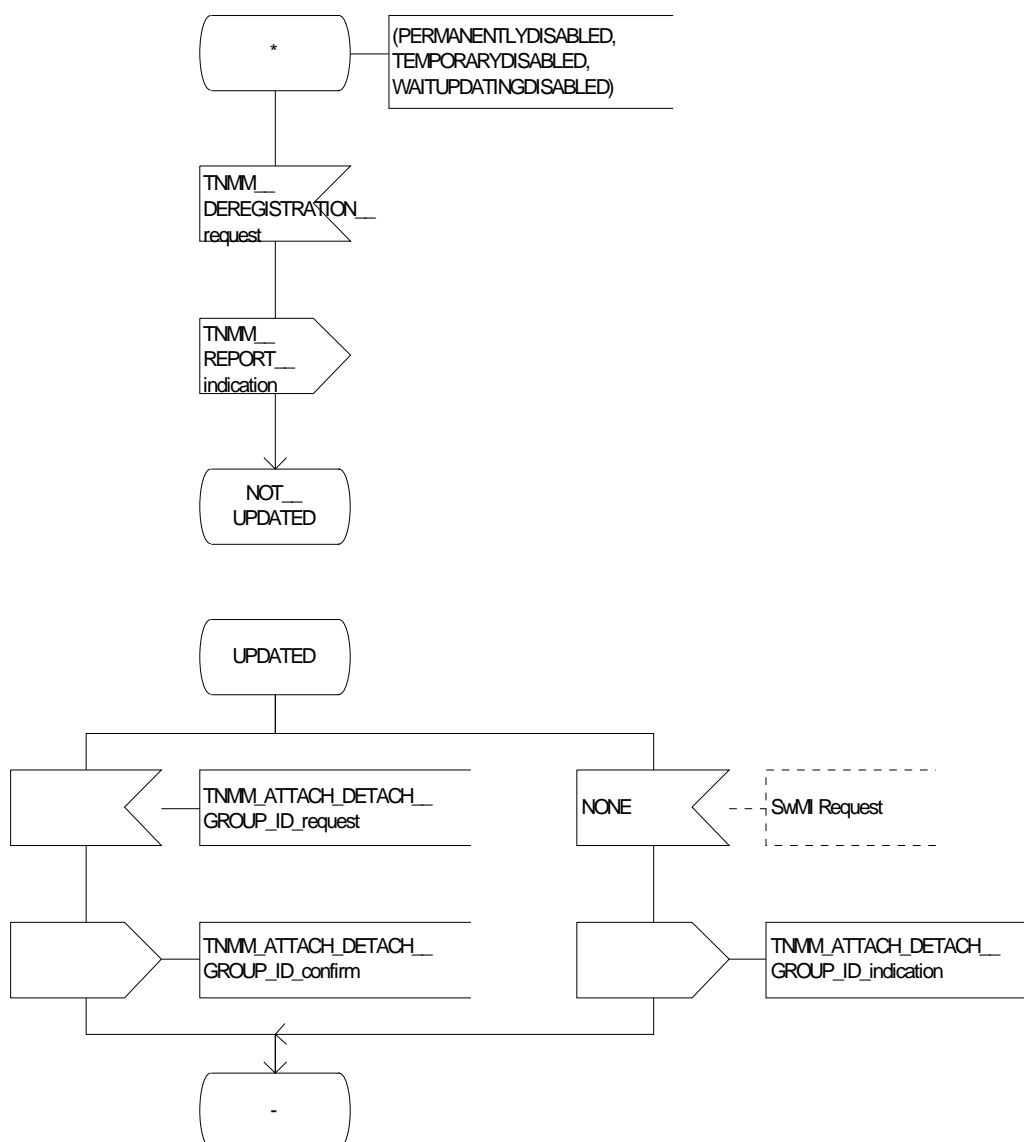


Figure 42: MM service state diagram (sheet 4 of 4)

Figure 43: Void

Figure 44: Void

Figure 45: Void

## 16 MM protocol

### 16.1 Introduction

This clause defines for the MS the TETRA MM protocol. This is the network layer protocol that shall be used to provide the MM service (see clause 15). This clause defines the protocol functions required for operation as an end system (i.e. providing service to an end user).

This clause specifies:

- procedures for registration and de-registration of a MS;
- procedures for negotiating the energy saving scheme to be used;

- procedures for moving to direct mode and returning to trunking mode operation;
- procedures for requesting direct mode dual watch operation; and
- procedures for attachment/detachment of group identities.

In addition to this clause EN 300 392-7 [11] specifies security related parts of the MM protocol and ETS 300 396-5 [14] specifies direct mode gateway related parts of the MM protocol.

The procedures are defined in terms of:

- interactions among peer network entities through the exchange of PDUs;
- interactions between a network entity and a network service user through the exchange of network service primitives;
- interaction between a network entity and an underlying service provider through the exchange of service primitives.

The timer actions in the following procedures are defined:

- start: the timer shall be reset and started to measure time as indicated in the timer parameter value (independently of the current timer count); and
- stop: the timer shall be stopped and no further actions shall be taken against that timer any more before next starting of the timer.

NOTE: This clause does not use any timer re-start where the timer is halted for a period of time and then counting continues without resetting the timer.

## 16.2 MM procedures

### 16.2.1 General

The internal organization of the network layer including the MM entity is described in the V+D protocol architectures (see EN 300 392-1 [9], clause 6).

The underlying services offered are those of the MLE, refer to clause 17 and EN 300 392-1 [9], clause 14.

### 16.2.2 Services provided by the protocol

The following services offered have been described in clause 15:

- registration on user demand;
- registration initiated by MLE (caused by roaming or migration);
- registration requested by SwMI;
- de-registration due to user request;
- energy saving mode change to user request;
- moving to direct mode and returning to trunking mode operation to user request;
- direct mode dual watch operation to user request; and
- attachment/detachment of group identities by user request;
- attachment/detachment of group identities by SwMI request.

In addition to this clause EN 300 392-7 [11] specifies security related MM services and ETS 300 396-5 [14] specifies direct mode gateway related MM services.

### 16.2.3 Underlying services assumed by the protocol

On the air interface the protocol shall use the MLE as defined in clause 17. The data transferring type when sending MLE-UNITDATA request shall be type "acknowledged" if not defined otherwise in this clause.

### 16.2.4 Services assumed from the local environment

No specific service shall be assumed from the Lower Layer Management Entity (LLME).

## 16.3 Protocol functions

The basic functions of the protocol defined in the present document for the MS are:

- to initiate PDU composition and decomposition;
- to initiate header error detection;
- to initiate activation of the selection of a cell sent to the MLE through an MLE-ACTIVATE request primitive at power up;
- to initiate a network code check from the information passed by the MLE using an MLE-LINK indication primitive. If a LA is a new LA, then registration may be required to be initiated by the MM through sending a U-LOCATION UPDATE DEMAND PDU to the infrastructure. If a network code is a new one then registration shall be initiated by the MM. The network may accept or reject the registration and the MM shall be informed by receiving a D-LOCATION UPDATE ACCEPT/REJECT;
- to update the MLE with a new registered area through an MLE-UPDATE request primitive;
- to initiate handling of exceptional procedures reported by the MLE (failures to requests);
- to supply or update the SSI (ASSI or ISSI) to be used to the MLE through MLE-IDENTITIES request primitive. This information may be either in the D-LOCATION PROCEEDING or in the D-LOCATION UPDATE ACCEPT PDU received by the MM;
- to supply or update the complete list of GSSIs to be used to the MLE through MLE-IDENTITIES request primitive. This information shall be either in the D-LOCATION UPDATE ACCEPT, D-ATTACH/DETACH GROUP IDENTITY or D-ATTACH/DETACH GROUP IDENTITY ACKNOWLEDGEMENT PDU received by the MM;
- to send and receive PDUs to and/or from the sub-layer MLE through MLE-UNITDATA request and indication primitive. The received PDUs can be handled locally by the MM or routed to the user application;
- to send and receive PDUs to and/or from the sub-layer MLE through MLE-PREPARE request and indication;
- to initiate the update criteria with the monitoring of other possible cells using an MLE-UPDATE request primitive following an infrastructure request;
- to initiate detach handling through a TNMM DEREGISTRATION request from the user, the MM shall then send a message to the infrastructure;
- to initiate energy saving mode handling following a change requested by the user, the new value may be negotiated by the MM through transmitting it to the network in a energy saving mode information element.
- to allow the MLE to indicate to other layer 3 entities that MM is involved in an individually addressed signalling exchange with the SwMI by sending (to the MLE) an MLE-BUSY request;
- to allow the MLE to indicate to other layer 3 entities that MM is no longer busy by sending an MLE-IDLE at the conclusion of such an exchange;
- to allow the MLE to remove access to communication resources for the other layer 3 entities by sending MLE-CLOSE;

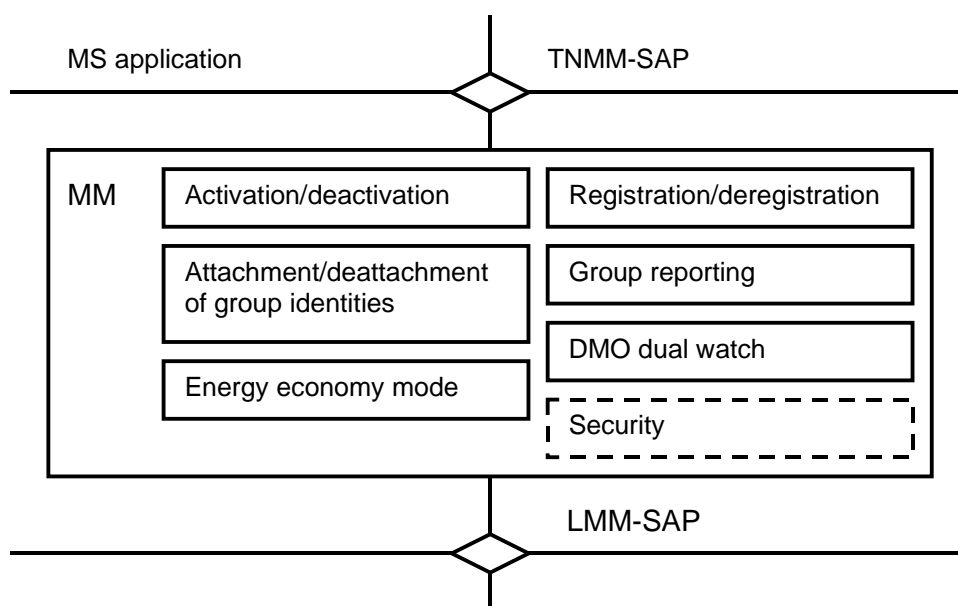
- to allow the MLE to provide access to communication resources for other layer 3 entities after successful registration by sending MLE-OPEN.

On the infrastructure side, the MM functions should be symmetrical, except activation of the selection of a cell which does not exist. Figure 46 summarises the MM functions.

The different protocol procedures are shown in the present document by the primitive sequences and PDU exchanges. The scenarios outlined are:

- de-registration;
- energy saving mode change;
- user request registration;
- network request registration;
- MLE initiated registration;
- user request attachment/detachment of group identities;
- network request attachment/detachment of group identities;
- moving to direct mode and returning to trunking mode operation; and
- requesting direct mode dual watch operation.

Figure 46 indicates the main functions of the MM.



NOTE: Security functions are defined in EN 300 392-7 [11].

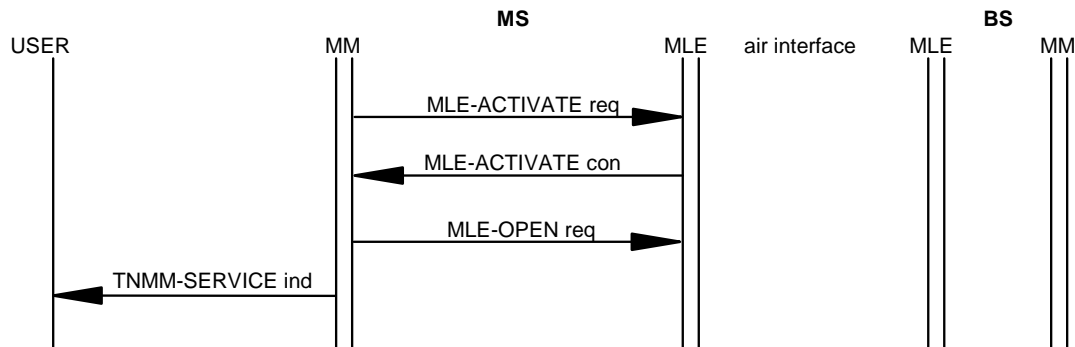
**Figure 46: MM main functions on the MS**



## 16.3.1 Activation and control of underlying MLE Service

### 16.3.1.1 Activation procedure

If the MS has its ITSI or TEI or both been permanently disabled the MS shall remain disabled at power up and shall not activate any of the protocol entities, refer to EN 300 392-7 [11]. The following describes the procedure for MSs that have not been permanently disabled.



**Figure 47: MM Activation procedure, successful cell selection**

At power up, or similar start up such as a change of SIM card, the MM shall issue an MLE-ACTIVATE request primitive. The MLE-ACTIVATE request primitive shall contain a list of valid mobile network identities.

When the MS performs initial cell selection (see clause 18.3.4.6), MM shall wait for the reception of either a MLE-ACTIVATE confirm or MLE-ACTIVATE indication primitive.

Upon receipt of an MLE-ACTIVATE indication primitive, the MM entity may issue a new MLE-ACTIVATE request primitive with a revised list of cell selection parameters. If no new parameters for a cell selection are available MM shall then inform the user application with a TNMM-SERVICE indication primitive issuing that the MS is "out of service".

Upon receipt of an MLE-ACTIVATE confirm primitive, the MM entity shall check whether the selected cell requires registration as follows:

- a) registration mandatory:
  - the MM shall inform the user application with TNMM-SERVICE indication issuing that the MS is "in service waiting for registration".
- b) registration is not required:
  - the MM shall open the communication resources to the other higher layer entities by issuing an MLE-OPEN request primitive to MLE which shall pass it to other entities. This MLE-OPEN request primitive shall be accompanied by a list of currently valid subscriber identities (ITSI, GTSI) in an MLE-IDENTITIES request primitive. The MM shall inform the user application with TNMM-SERVICE indication indicating that the MS is "in service". The MLE-OPEN request shall not be issued if the MS has previously been temporarily disabled and not subsequently enabled by the infrastructure.

### 16.3.1.2 Deactivation procedure

This procedure shall be invoked at power down or if the ITSI is detached from the MS. The MM shall issue an MLE-CLOSE request to MLE to indicate that access to the communication resources has been closed to the other higher layer entities; SNDP and CMCE. MM shall then issue an MLE-DEACTIVATE request primitive.

### 16.3.1.3 Maintenance procedures

#### 16.3.1.3.1 Report and cancel handling

The cancel and report procedure may be implemented in the MS and if used the following shall apply.

Incoming MLE-REPORT indications should indicate the following events:

- a PDU has been stored by the DLL ready for transmission. At this stage the transmission may be cancelled using a MLE-CANCEL request and no information will be sent over the air interface;
- the first transmission of whole PDU. The BS may have received the PDU, but MS has not yet received an acknowledgement. At this stage the layer 2 process may be stopped using a MLE-CANCEL request, but MM cannot rely on the cancellation and may receive a response to the sent PDU;
- a PDU has not been successfully transmitted by layer 2 Cancellation is no longer possible, but the BS may have received the PDU correctly and MM cannot rely on the cancellation and may receive a response to the sent PDU;
- a PDU has been successfully transmitted by layer 2. Cancellation is no longer possible.

The MLE-CANCEL request can minimise the risk of adding extra load to the air interface, e.g. when a user application initiated registration request is buffered by the lower layers waiting for allowance to make random access attempt, which can take a considerable amount of time. If the user application during this waiting period changes its decision and wants to de-register, the application shall send a TNMM-DEREGISTRATION request which will be converted to a MLE-CANCEL request depending on the status of the transmission as stated above.

#### 16.3.1.3.2 Stealing permission and stealing repeats flag handling

For each PDU sent by MM, stealing permission and stealing repeats flag are set to some value. The values used are outside of the scope of the present document.

#### 16.3.1.3.3 Busy handling

An MLE-BUSY request shall be sent to the MLE by the MM when it initiates an individually addressed signalling exchange with the SwMI, e.g. registration, authentication, group management etc., and an MLE-IDLE request shall be sent to the MLE when the MM has completed any such signalling. This allows the MLE to indicate to other entities that MM is currently busy. MM shall also inform the state to the user application by sending TNMM-SERVICE indication primitive with "MM busy" or "MM idle" indication. The behaviour of the user application is outside the scope of the present document. However it is recommended that the user application does not initiate new signalling exchange (e.g. group attachment) while the MM is busy in another action.

#### 16.3.1.3.4 Activity handling

An MLE-ACTIVITY request with indication "stay alive" shall be sent to the MLE by the MM when it initiates an signalling exchange with the SwMI for which it waits for layer 3 response. An MLE-ACTIVITY request with indication "sleeping permitted" shall be sent to the MLE when the MM has completed any such signalling. This allows the MLE to temporarily withdraw the energy economy mode when MM is waiting for a response from the SwMI.

## 16.4 Registration procedure

The registration procedures are illustrated in figure 48 to figure 51 respectively. Registration can be initiated by the MLE, by the user application or it can be requested by the infrastructure.

Security related information elements and their usage are defined in EN 300 392-7 [11].

A MS in the temporarily disabled state shall set the location update type information element to "Disabled MS updating" in all registration cases. The MS shall remain in the temporarily disabled state (i.e. access to the communication resources shall only remain open for the MM entity). The temporarily disabled state is defined in EN 300 392-7 [11].

MS shall assume at the start of registration to be unregistered except for forward and periodic registration, refer to clause 16.4.1.2. If there is no response to the registration the MS shall assume its previous state to be valid. In case the MS has to perform cell reselection before receiving acknowledgement to registration request, the MS shall consider itself unregistered and shall send a registration request on the new cell. The location update element type applied shall be the same as for the interrupted registration, except in case when MS was performing periodic registration; then Ms shall use either value "roaming location updating" or "call restoration roaming location updating" depending whether there is an active circuit mode call.

The behaviour of an MS in case it has to perform cell reselection before receiving acknowledgement to other requests related to MM procedures (e.g. group attachment/detachment), is outside the scope of the present document.

## 16.4.1 MLE initiated registration procedure

The MLE shall initiate normal or forward registration when cell reselection into a location area outside of the current registered area is indicated and the new cell requires registration. In addition, if the MS selects a cell that indicates in the BS service details that "System-wide services temporarily not supported" the MLE shall indicate a need for normal registration in case the new cell belongs to the registered area of the MS and the new cell requires registration.

Cell reselection into a new cell shall be notified to MM by the receipt of an MLE-LINK indication primitive. The MLE-LINK indication shall supply the MNC, MCC and the LA of the new cell.

The registration type can be either normal, forward or periodic registration indicated by registration type parameter received in the MLE-LINK indication from the MLE. The normal registration is described in clause 16.4.1.1, the forward registration in clause 16.4.1.2 and periodic registration in clause 16.4.2. Forward registration shall be applied only in case there is a circuit mode call active and the MS is attempting announced type 1 cell reselection.

When BS service details change to "System-wide services supported" and the MS is temporary registered, see clause 16.4.8, the MLE shall indicate a need for periodic registration.

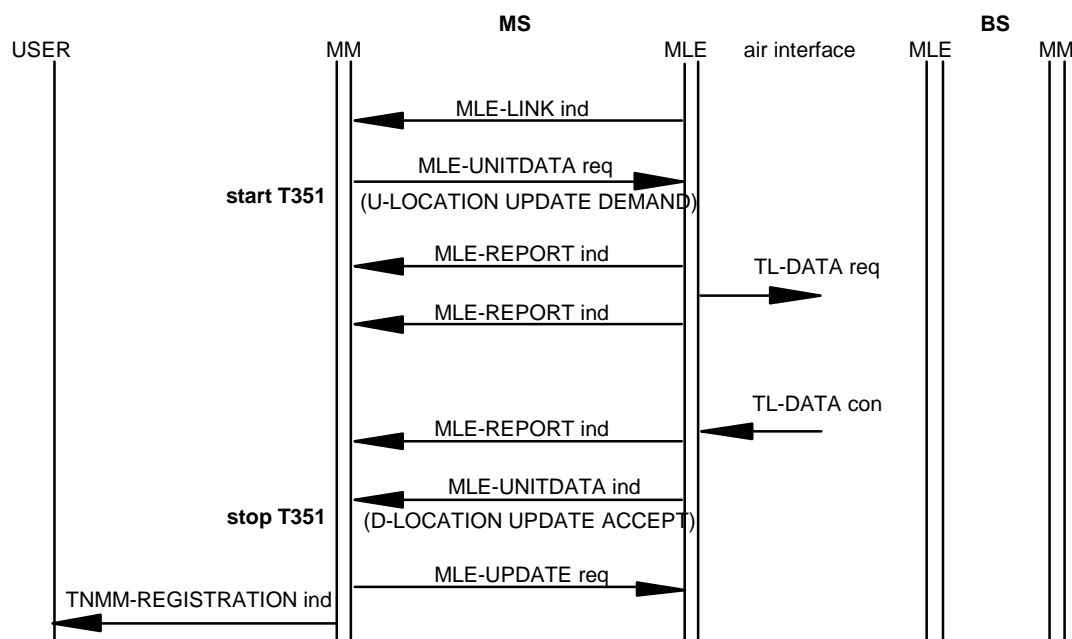
### 16.4.1.1 Normal registration

The registration procedure can be carried out with, or without, identity exchange (see EN 300 392-1 [9], clause 9). Identity exchange shall be required where the MS migrates to a new TETRA network other than the home network.

Normal registration case a) "roaming" shall be applied when the MS with the same ITSI has already successfully registered to the network, refer to figure 48.

Normal registration case b) "migrating; MS migrates to other than its home network" shall be applied when the MNC or MCC of the ITSI differ from the LANC and LACC of the new cell to which the MS now registers (visited SwMI) and there is no valid registration of the ITSI to the new network).

Normal registration case c) "migrating; MS migrates back to its home network" shall be applied when the MNC and MCC of the ITSI are the same as the LANC and LACC of the new cell to which the MS now registers (home SwMI and there is no valid registration of the ITSI to the new network), refer to figure 48. Normal registration case d) "temporarily disabled MS" shall always be applied if the TEI or ITSI of the MS has been temporarily disabled, refer to figure 48.



NOTE: MLE-REPORT shown in this figure applies to all scenarios where MM sends a PDU.

**Figure 48: MLE initiated registration in cases a), b) and d)**

For all cases a) to d) the information element "Group report response" shall not be present in these registration PDUs.

a) roaming:

- The MM entity shall send a U-LOCATION UPDATE DEMAND PDU to the MLE with an MLE-UNITDATA request primitive. The location update type information element in the PDU shall be set either to "roaming location updating", or if there was a circuit mode call active, to "call restoration roaming location updating". If "roaming location updating" PDU priority is set to 3 and if "call restoration roaming location updating" PDU priority is set to 5. Upon sending the U-LOCATION UPDATE DEMAND PDU the MM shall assume that group identities with parameter value "Attachment for next location update required" are no longer attached. If MS wishes to receive signalling on those group identities either the U-LOCATION UPDATE DEMAND PDU may include a request for attachment/detachment of those group identities in the group identity location demand information element or MM may later attach the groups using attach mechanism, see clause 16.8.2. The PDU may contain the SSI (or SSI + address extension) information elements. If present, they shall contain the ISSI of the MS and MNI of the MS, respectively. The PDU may contain characteristics of the MS terminal in class of MS information element. The PDU may also contain energy economy mode information in the energy saving mode information element, if so the timer T352 shall be started. The MS may also request to append the new LA into the current RA in the request to append LA information element. The information element LA information shall not be present in the PDU because this is not a forward registration. The MLE-UNITDATA request primitive parameters shall indicate that the identity to be used shall be the ASSI/(V)ASSI, if one has been issued, or the ISSI in the case where an ASSI/(V)ASSI has not been issued. Timer T351 shall be started.

NOTE 1: If ASSI or (V)ASSI is available at layer 2, it is recommended that the MS does not reveal its true identity by sending ISSI in layer 3.

## b) Migrating; MS migrates to other than its home network:

- The MM entity shall send a U-LOCATION UPDATE DEMAND PDU to the MLE with an MLE-UNITDATA request primitive. The location update type information element in the PDU shall be set either to "migrating location updating", or if there was a circuit mode call active, to "call restoration migrating location updating". If "migrating location updating" PDU priority shall be set to 3 and if "call restoration migrating location updating" PDU priority shall be set to 5, the PDU shall include the MNI of the MS in the address extension information element and may include the ISSI of the MS in the SSI information element. This first U-LOCATION UPDATE DEMAND PDU shall not include optional information elements class of MS, energy saving mode and group identity location demand. The information element LA information shall not be present in the PDU because this is not a forward registration. The primitive parameters shall indicate to the lower layers that the USSI of the MS shall be used. Timer T351 shall be started.

NOTE 2: The use of the SSI information element in the U-LOCATION UPDATE DEMAND PDU is not recommended as it will result in fragmentation in MAC layer.

- If SwMI is ready to reject the registration at this stage it shall send D-LOCATION UPDATE REJECT PDU which shall include the MNI of the MS. The SSI in the layer 2 shall be the USSI. Otherwise SwMI shall send D-LOCATION UPDATE PROCEEDING PDU allocating (V)ASSI.
- Upon receipt of the D-LOCATION UPDATE PROCEEDING, the MM shall check whether the MCC and MNC, included in the address extension information element, correspond to those values held in the MS. If the MNC or MCC do not correspond to the transmitted values, no further action shall be taken against that PDU. If the MNC and MCC do correspond to the transmitted values, the MM shall extract the (V)ASSI from the SSI field and send this to the MLE by using MLE-IDENTITIES request primitive. Timer T351 shall be stopped. The MS shall immediately change to use the (V)ASSI in all subsequent signalling except for the layer 2 acknowledgement for the received D-LOCATION UPDATE PROCEEDING PDU, where the USSI shall be used.
- The MM entity shall send a second U-LOCATION UPDATE DEMAND PDU to the MLE with an MLE-UNITDATA request primitive. This shall have PDU priority 6. The PDU shall contain the MNI of the MS in the address extension information element and the ISSI of the MS in the SSI information element. The PDU shall contain characteristics of the MS terminal in the class of MS information element. The PDU may contain energy economy mode information in the energy saving mode information element, if so the timer T352 shall be started. Upon sending the U-LOCATION UPDATE DEMAND PDU the MM shall assume that the group identities are no more attached. If MS wishes to receive signalling on those group identities either the U-LOCATION UPDATE DEMAND PDU may include a request for attachment/detachment of those group identities in the group identity location demand information element or MM may later attach the groups using attach mechanism, see clause 16.8.2. The MM shall not request to append the new LA into the current RA in the request to append LA information element. The information element LA information shall not be present in the PDU because this is not a forward registration. The location update type information element in the PDU shall be set to demand location updating. The primitive parameters shall indicate that the identity to be used shall be the SSI ((V)ASSI). Timer T351 shall be started.

## c) Migrating; MS migrates back to its home network:

- The MM entity shall send a U-LOCATION UPDATE DEMAND PDU to the MLE with an MLE-UNITDATA request primitive. The location update type information element in the PDU shall be set either to "migrating location updating", or if there was a circuit mode call active, to "call restoration migrating location updating". If "migrating location updating" PDU priority shall be set to 3 and if "call restoration migrating location updating" PDU priority shall be set to 5. The PDU shall include the MNI of the MS in the address extension information element and may include the ISSI of the MS in the SSI information element. The PDU shall contain characteristics of the MS terminal in the class of MS information element. The PDU may contain energy economy mode information in the energy saving mode information element, if so the timer T352 shall be started. Upon sending the U-LOCATION UPDATE DEMAND PDU the MM may assume that the group identities which have earlier been attached in the home network with parameter value "Attachment not needed" are attached and shall assume that all other group identities with other parameter values are no more attached. If MS wishes to receive signalling on those unattached group identities either the U-LOCATION UPDATE DEMAND PDU may include request for attachment/detachment of group identities in the group identity location demand information element or MM may later attach the groups using attach mechanism, see clause 16.8.2. The MM should not try to attach the group identities with parameter values "Attachment not allowed for next ITSI attach" or which have been permanently detached in the home network. The MS shall not request to append the new LA into the current RA in the request to append LA information element. The information element LA information shall not present in the PDU because this is not a forward registration. The primitive parameters shall indicate to the lower layers that the address to be appended shall be the ISSI. Timer T351 shall be started.

## d) Temporarily disabled MS:

- a), b) or c) shall apply with the location update type information element set to "Disabled MS updating". The MS shall remain in the temporarily disabled state (i.e. access to the communication resources shall only remain open for the MM entity). The temporarily disabled state is defined in EN 300 392-7 [11]. In the temporary disabled state the group attachments are not allowed and call restoration is not applicable.

If SwMI accepts the registration it shall send a D-LOCATION UPDATE ACCEPT PDU.

For cases a), b), c) and d) :upon receipt of the D-LOCATION UPDATE ACCEPT PDU received with an MLE-UNITDATA indication primitive, MM shall if present, extract the MNI from the address extension information element and check that it is the same as MNI of the MS ITSI and, if that is the case or the MNI is not present, then the MM shall:

NOTE 3: The address extension information element cannot act as complete safe guard because there is no information element for the ISSI in the PDU.

- If present, extract the ASSI or (V)ASSI from the SSI field.
- If the U-LOCATION UPDATE DEMAND contained a request for attachment/detachment of group identities, the MM shall inspect the group identity location accept information element to find out if the SwMI accepted them. In case the group identity location accept information element is not present in the D-LOCATION UPDATE ACCEPT PDU, the MS shall assume the group attachment/detachment failed. The MS shall treat the failure as equivalent to T353 timer expiry. If the group attachment acknowledgement does not contain explicit group lifetime, then the applied lifetime is outside the scope of the present document.
- The MM shall inform the MLE of ASSI or (V)ASSI and the accepted and thus attached group identities with related (V)GSSIs when applicable and shall command MLE to remove detached group identities with an MLE-IDENTITIES request primitive, see clause 16.8. The MS shall immediately change to use the ASSI or (V)ASSI in layer 2 in all subsequent signalling except for the layer 2 acknowledgement for the received D-LOCATION UPDATE ACCEPT PDU, where the SSI used shall be the same as the layer 2 address used to transfer the D-LOCATION UPDATE ACCEPT PDU.
- Timer T351 shall be stopped.
- MM shall, if information elements are present, extract from the PDU the information concerning SCCHs and minimum mode (18<sup>th</sup> frame) monitoring, energy saving information, subscriber class and new registered area information, and inform these to the lower layers in an MLE-INFO request primitive, refer to clauses 16.7.1 and 16.4.9.

- If the new registered area information element is not present in the PDU, the MS shall consider the current RA to include only the current LA the MS just registered on with no registration timeout.
- If the new registered area information element is present, then the new RA is that defined by the LAs in the New Registered Area information element and the LA timer associated with each LA shall be started. SwMI shall include the LA into which the registration was made in the New registered area information element. Refer to clause 16.4.6 for LA time-out.
- The MS MM shall issue an MLE-UPDATE request primitive indicating a registration result of "Success" or "Temporary registration" and the LAs in the RA. MM shall inform the user application that the MS is ready for use by issuing a TNMM-REGISTRATION indication primitive containing registration and group attachment/detachment information.
- Where an energy economy mode has been requested and the MS is not informed of the outcome of this request in the D-LOCATION UPDATE ACCEPT PDU, the information shall be conveyed in a separate D-MM STATUS PDU as described in clause 16.7.1.
- For subscriber class procedures, see clause 16.4.

For cases b) and c) (MS migration to other than its home network, or MS migrates back to its home network), the optional Default group attachment lifetime information element may be present in the D-LOCATION UPDATE ACCEPT PDU. If the element is not present, the MS shall assume the lifetime "Attachment for next ITSI-Attach required" to be the default lifetime.

If SwMI rejects the registration it shall send a D-LOCATION UPDATE REJECT PDU. Upon receipt of a D-LOCATION UPDATE REJECT PDU MM shall if present, extract the MNI from the address extension information element and check that it is the same as MNI of the MS ITSI and, if that is either the case or the MNI is not present, then the MM shall:

NOTE 4: The address extension information element cannot act as complete safe guard because there is no information element for the ISSI in the PDU.

- stop timers T351 and T352, if started;
- inform the user application about registration failure by issuing a TNMM-REGISTRATION indication primitive containing "failure" and the reject cause;
- analyse the reject cause:
  - in the event that a Congestion or Network failure is reported, MM may re-try registration after a suitable time or issue an MLE-UPDATE request primitive with a registration result of "cell rejection" in order that the MLE initiates cell reselection procedures as defined in clause 18.3.4.7;
  - in the event that "LA not allowed", "Service not subscribed" or "Roaming not supported" is reported, MM shall issue an MLE-UPDATE request primitive with a registration result of "LA rejection" in order that the MLE initiates cell reselection procedures as defined in clause 18.3.4.7;
  - in the event that a ITSI/ATSI unknown is reported, if the MAC header contains ASSI or (V)ASSI, the MS shall re-try registration using the USSI or ISSI in layer 2 depending whether the MS is registering to its home network. In case MS is registering to its home network, it shall perform registration as defined in clause 16.4.2 case b) new ITSI. In case MS is registering to foreign network, it shall perform registration as defined in clause 16.4.1.1 case b) migrating; MS migrates to other than its home network. If the MAC header contains ISSI or USSI, MM shall issue an MLE-UPDATE request primitive with a registration result of "System rejection" in order that the MLE initiates cell reselection procedures as defined in clause 18.3.4.7;
  - in the event of a Mandatory element error or Message inconsistency error is reported, the MS shall be allowed at least one registration re-try;
  - in the event of an Illegal MS or Migration not supported is reported, MM shall issue an MLE-UPDATE request primitive with a registration result of "System rejection" in order that the MLE initiates cell reselection procedures as defined in clause 18.3.4.7;
  - the reject cause Forward registration failure shall not applicable to normal registration;

- all other reject causes are outside the scope of this clause of the present document, refer also to EN 300 392-7 [11];
- in the event that the serving cell was the only cell available MM shall issue an MLE-CLOSE request to the MLE and TNMM-SERVICE indication to the TNMM-SAP indicating that the MS is "out of service". The MM shall consider the MS to be de-registered and hence apply the activation procedure as defined in clause 16.3 in order to get into service again.

NOTE 5: When to apply the activation procedure, after no service is obtained, is outside the scope of the present document.

### 16.4.1.2 Forward registration

Forward registration shall be applied in case there is a circuit mode call active and the MS is attempting announced type 1 cell reselection and the MS with the same ITSI has already successfully registered to the network and the cell to which it now registers does not belong to its current RA (home and visited SwMI).

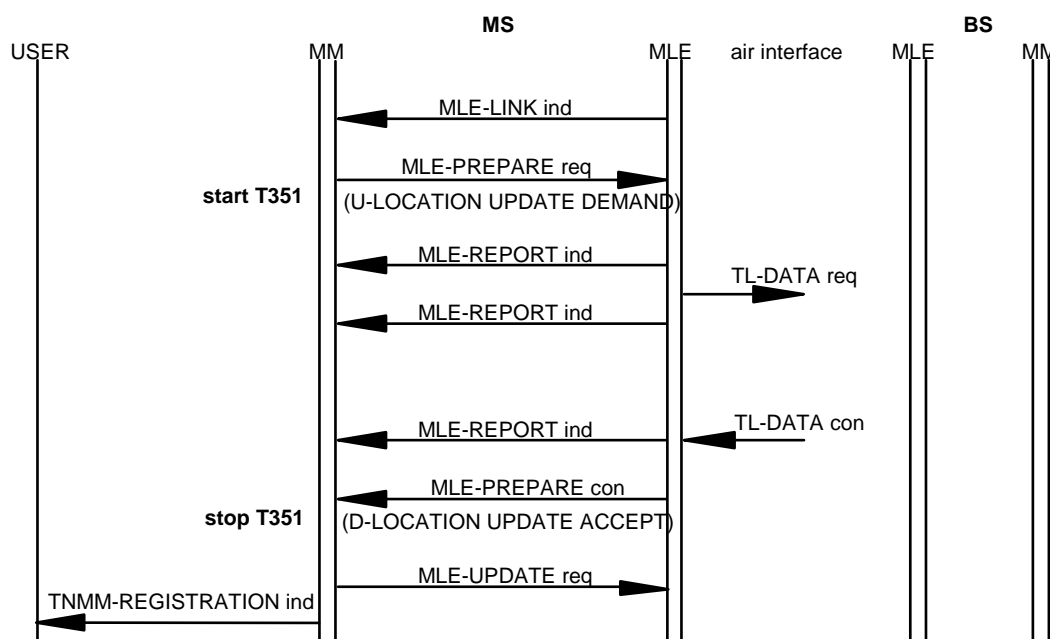


Figure 49: MLE initiated forward registration

The location update type information element in the U-LOCATION UPDATE DEMAND PDU shall be set to "call restoration location updating". The U-LOCATION UPDATE DEMAND PDU may contain energy economy mode information in the energy saving mode information element, if so the timer T352 shall be started. The PDU may contain the SSI and address extension information elements, if present, the information elements shall contain the ISSI of the MS an MNI of the MS, respectively. The PDU may also contain characteristics of the MS terminal in class of MS information element. The MS may also request to append the new LA into the current RA in the request to append LA information element. The PDU shall contain the location area identification of the new cell, where to the MS is forward registering, in the LA information element. Upon sending the U-LOCATION UPDATE DEMAND PDU the MM shall assume that group identities with parameter value "Attachment for next location update required" are not attached on the new LA. If MS wishes to receive signalling on those group identities the U-LOCATION UPDATE DEMAND PDU shall include a request for attachment/detachment of those group identities in the group identity location demand information element or MM may later attach the groups using attach mechanism, see clause 16.8.2. The MLE-UNITDATA request primitive parameters shall indicate that the identity to be used shall be the ASSI/(V)ASSI, if one has been issued, or the ISSI in the case where an ASSI/(V)ASSI has not been issued. Timer T351 shall be started.

NOTE 1: If ASSI or (V)ASSI is available at layer 2, it is recommended that the MS does not reveal its true identity by sending ISSI in layer 3.

"Group report response" shall not be present in forward registration PDUs.

If the SwMI accepts the registration it shall send a D-LOCATION UPDATE ACCEPT PDU in an MLE D-NEW CELL PDU as defined in clause 18.3.4.



Upon receipt of the D-LOCATION UPDATE ACCEPT by the MLE-PREPARE confirm the MM shall if present, extract the MNI from the address extension information element and check that it is the same as MNI of the MS ITSI and, if that is either the case or the MNI is not present, then the MM shall:

- Extract the ASSI or (V)ASSI from the SSI field. The MS shall immediately change to use the ASSI/(V)ASSI in layer 2 in all subsequent signalling except for the layer 2 acknowledgement for the received D-LOCATION UPDATE ACCEPT PDU, where the same SSI shall be used as was used in layer 2 in the D-LOCATION UPDATE ACCEPT PDU. MM shall, if present, extract the MNI of the MS from the address extension information element. If the U-LOCATION UPDATE DEMAND contained request for attachment/detachment of group identities, the MM shall inspect the group identity location accept information element to find out if the SwMI accepted them. In case the group identity location accept information element is not present in the D-LOCATION UPDATE ACCEPT PDU, the MS shall assume the group attachment/detachment failed. The MS shall treat the failure as equivalent to T353 timer expiry. If the group attachment acknowledgement does not contain explicit group lifetime, then the applied lifetime is outside the scope of the present document. MM shall inform the MLE of ASSI or (V)ASSI and accepted and thus attached group identities and related (V)GSSI, when applicable with an MLE-IDENTITIES request primitive. MM shall, if information element is present, extract from the PDU the information concerning new registered area information, and inform these to the lower layers in an MLE-INFO request primitive.

NOTE 2: The address extension information element cannot act as complete safe guard because there is no information element for the ISSI in the PDU.

- If the new registered area information element is not present in the PDU, the MS shall consider the current RA to include only the current LA the MS just registered on with no registration timeout.
- If the new registered area information element is present, then the new RA is that defined by the LA's in the New registered area information element and the LA timer associated with each new LA shall be started.

NOTE 3: The LA from which the MS is roaming is not part of the new RA unless that LA is included in the New registered area information element.

- Timer T351 shall be stopped. MM shall, if information elements are present, extract from the PDU the information concerning SCCH, energy saving information (economy mode, and minimum mode (18th frame) monitoring), subscriber class, if present, and inform these to the lower layers in an MLE-INFO request primitive, refer to clauses 16.7.1 and 16.4.9.
- For subscriber class procedures see clause 16.4.

The MS MM shall issue an MLE-UPDATE request primitive indicating a registration result of "Success" or "Temporary registration" and the LAs in the RA. MM shall inform the user application that the MS is ready for use by issuing a TNMM-REGISTRATION indication primitive containing registration and group attachment/detachment information. Where an energy economy mode has been requested and the MS is not informed of the outcome of this request in the D-LOCATION UPDATE ACCEPT PDU, the information shall be conveyed in a separate D-MM STATUS PDU as described in clause 16.7.1.

If the SwMI rejects the registration it shall send a D-LOCATION UPDATE REJECT PDU. Upon receipt of a D-LOCATION UPDATE REJECT, MM shall if present, extract the MNI from the address extension information element and check that it is the same as MNI of the MS ITSI and, if that is the case or the MNI is not present, then the MM shall:

NOTE 4: The address extension information element cannot act as complete safe guard because there is no information element for the ISSI in the PDU.

- stop timers T351 and T352, if started;
- inform the user application about registration failure by issuing a TNMM-REGISTRATION indication primitive containing "failure" and the reject cause;
- remain registered in the current cell with previous ASSI, (V)ASSI, GSSIs and (V)GSSIs as appropriate.

- analyse the reject cause:
  - in the event that a "forward registration failure" is reported, MM shall issue an MLE-UPDATE request primitive with a registration result of "forward registration failure", refer to clause 17.3.9, in order that the MLE initiates cell reselection procedures as defined in clause 18.3.4.7.
  - in the event that a LA unknown, MM shall issue an MLE-UPDATE request primitive with a registration result of "LA rejection" in order that the MLE initiates cell reselection procedures as defined in clause 18.3.4.7.
  - all other reject causes are analysed and acted similarly as with normal registration (clause 16.4.1.1).

In the temporary disabled state the CMCE is closed and consequently call restoration and forward registration are not applicable.

## 16.4.2 User application initiated registration procedure

User application initiated registration shall be available whenever the MS is camped on a cell, i.e. has received TNMM-SERVICE indication stating that the MS is "in service waiting for registration" or "in service". It shall be applied whenever an identity is attached to the MS. The user application initiated registration can be used at power up and at any time provided that an ITSI is available either within the MS, and shall be supplied with the TNMM-REGISTRATION request primitive, see figure 50.

In case the status of the BS changes from "system wide services temporarily not supported" to "normal mode" and the MS has a temporary registration to the cell, the MLE shall indicate a need for periodic registration to MM by sending an MLE-LINK indication. In such a case or if a LA timer expires and the LA is the current LA, the MM shall inform user application by sending a TNMM-REGISTRATION indication with registration parameter set to "LA registration expired" and LA parameter to the current LA so that the application could initiate registration in a suitable time e.g. after completing on-going call.

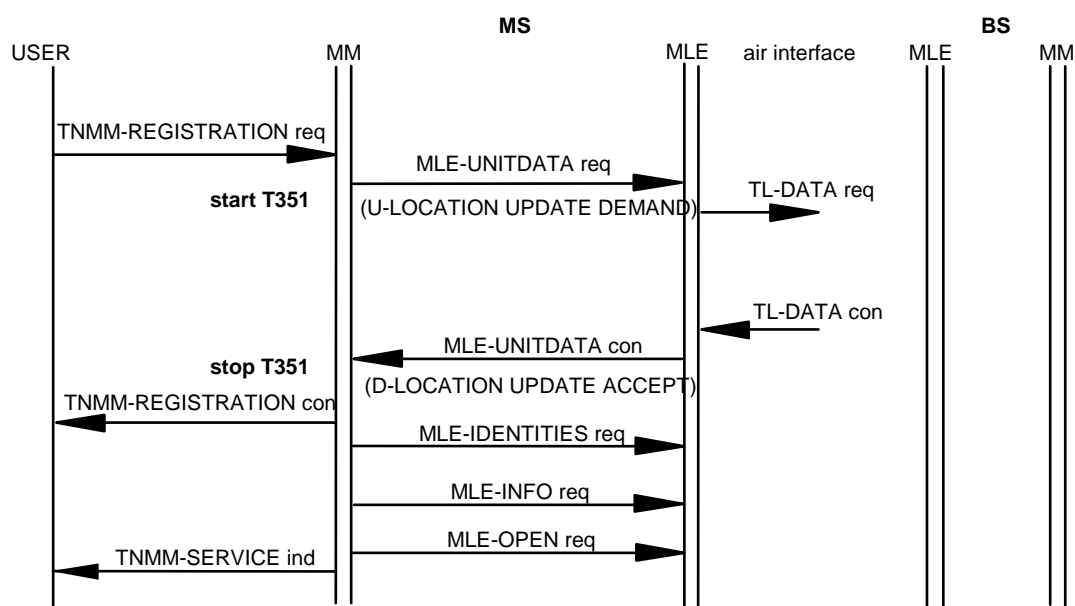


Figure 50: User application initiated registration in cases a) and b)

MM shall check whether the TNMM-REGISTRATION request primitive contains a request to perform a periodic registration or to select a specified MCC and MNC and possible LA. In case the TNMM-REGISTRATION request is not a periodic registration request, MM shall send the preferred network / LA list in an MLE-LINK request to MLE and shall wait for MLE-LINK indication. If MM receives MLE-ACTIVATE indication from MLE because MLE is not able to select the requested MCC, MNC or LA, MM shall inform the user application by issuing a TNMM-REGISTRATION confirm primitive indicating "no preferred cell found". The user application may then provide new MCC, MNC and/or LA information to MM using a TNMM-REGISTRATION request primitive.

If the MS is in state "in service" and the user application was not requesting periodic registration, MM shall wait for an MLE-LINK indication from the MLE and perform registration as specified in clause 16.4.1.

If the MS is in state "in service waiting for registration", MM shall send an MLE-LINK request to MLE and wait for MLE-LINK indication. For a periodic registration request or after receiving an MLE-LINK indication from the MLE, MM shall ascertain whether there is a new ITSI being attached as follows:

- case a) "no new ITSI" shall be applied when the MS with the same ITSI has already successfully registered to the network (home and visited SwMI);
- case b) "new ITSI" shall be applied at power up registration or when there is no valid registration of the ITSI to the network and the MNC and MCC of the ITSI are the same as the LANC and LACC of the cell the MS is camped on (home SwMI);
- case c) "new un-exchanged ITSI" shall be applied at power up registration or when there is no valid registration of the ITSI to the network and the MNC or MCC of the ITSI differ from the LANC or LACC of the cell the MS is camped on (visited SwMI).

In addition a temporary disabled MS shall follow case d).

a) no new ITSI:

- MM shall send a U-LOCATION UPDATE DEMAND PDU to the MLE with an MLE-UNITDATA request primitive. This shall have PDU priority 3.
- The location update type information element in the PDU shall be set to "periodic location updating".
- The PDU may contain the SSI and address extension information elements, if present, the information elements shall contain the ISSI of the MS and MNI of the MS, respectively. The PDU may also contain the class of MS information element and energy saving mode information element, if so the timer T352 shall be started. Upon sending the U-LOCATION UPDATE DEMAND PDU the MM shall assume that group identities with parameter value "Attachment for next location update required" are no more attached. If MS wishes to receive signalling on those group identities either the U-LOCATION UPDATE DEMAND PDU may include request for attachment of those group identities in the group identity location demand information element or MM may later attach the groups using attach mechanism, see clause 16.8.2. The MLE-UNITDATA request primitive parameters shall indicate that the identity to be used shall be the ASSI/(V)ASSI, if one has been issued, or the ISSI in the case where an ASSI/(V)ASSI has not been issued. Timer T351 shall be started.

NOTE 1: If ASSI or (V)ASSI is available at layer 2, it is recommended that the MS does not reveal its true identity by sending ISSI in layer 3.

b) new ITSI:

- in this case at the beginning the communication resources are closed. The MM shall register with the home network using ISSI. MM shall send a U-LOCATION UPDATE DEMAND PDU to the MLE with an MLE-UNITDATA request primitive. This shall have PDU priority 6. The location update type information element in the PDU shall be set to "ITSI attach". The PDU shall also contain the characteristics of the MS terminal in the class of MS information element. The PDU may contain the SSI and address extension information elements, if present, the information elements shall contain the ISSI of the MS and MNI of the MS, respectively. The PDU may also contain energy economy mode information in the energy saving mode information element, if so the timer T352 shall be started. Upon sending the U-LOCATION UPDATE DEMAND PDU the MM may assume that group identities which have earlier been attached in the home network with parameter value "Attachment not needed" are attached and shall assume that all other group identities are no more attached. If MS wishes to receive signalling on the unattached group identities either the U-LOCATION UPDATE DEMAND PDU may include request for attachment/detachment of those group identities in the group identity location demand information element or MM may later attach the groups using attach mechanism, see clause 16.8.2. The MM should not try to attach the group identities with parameter values "Attachment not allowed for next ITSI attach" or which have been permanently detached in the home network. The MS shall not request to append the new LA into the current RA in the request to append LA information element. The information element LA information is not present in the PDU because this is not a forward registration. The primitive parameters shall indicate that the identity to be appended by the MAC shall be the SSI (ISSI). Timer T351 shall be started;

## c) new un-exchanged ITSI:

- in this case at the beginning the communication resources are closed. The MM shall register on a visited network using identity exchange. The MM entity shall send a U-LOCATION UPDATE DEMAND PDU with PDU priority 3 to the MLE with an MLE-UNITDATA request primitive and issue an MLE-BUSY request primitive to the MLE. The location update type information element in the PDU shall be set to "migrating location updating". The PDU shall include the MNI of the MS in the address extension information element and may include the ISSI of the MS in the SSI information element. There shall be no optional information elements class of MS, energy saving mode and group identity location demand in the PDU because they shall be present in the second U-LOCATION UPDATE DEMAND PDU, if needed. The information element LA information shall not present in the PDU because this is not a forward registration. The primitive parameters shall indicate to the lower layers that the USSI of the MS shall be used. Timer T351 shall be started;

NOTE 3: The use of the SSI information element in the U-LOCATION UPDATE DEMAND PDU is not recommended as it will result in fragmentation in MAC layer.

- if SwMI is ready to reject the registration at this stage it shall send D-LOCATION UPDATE REJECT PDU which shall include the MNI of the MS. The SSI in the layer 2 shall be the USSI. Otherwise SwMI shall send D-LOCATION UPDATE PROCEEDING PDU allocating (V)ASSI;
- upon receipt of the D-LOCATION UPDATE PROCEEDING PDU, the MM shall if present, extract the MNI from the address extension information element and check that it is the same as MNI of the MS ITSI and, if that is either the case or the MNI is not present, then MM shall:
  - extract the (V)ASSI from the SSI field and send this to the MLE by using MLE-IDENTITIES request primitive. The MS shall immediately change to use the (V)ASSI in all subsequent signalling except for the layer 2 acknowledgement for the received D-LOCATION UPDATE PROCEEDING PDU, where the USSI shall be used;
  - stop timer T351;
  - as the message is a response to a request made using the USSI, MM shall check that the MCC and the MNC included in the address extension information element, correspond to the MNI of the MS. This shall be used to ensure that if two mobiles request registrations using the same USSI that MM can distinguish between them:
    - if the MNIs do not match no action shall be taken;
    - if the MCC and the MNC do correspond the transmitted values, the MM entity shall reply with a second U-LOCATION UPDATE DEMAND PDU containing the MNI of the MS in the address extension information element and ISSI of the MS in the SSI information element, thus comprising the full ITSI to the MLE with an MLE-UNITDATA request primitive. The PDU shall also contain the class of MS information element. The PDU may also contain economy mode information in the energy saving mode information element, if so the timer T352 shall be started. Upon sending the U-LOCATION UPDATE DEMAND PDU the MM shall assume that all group identities are no more attached. If MS wishes to receive signalling on those unattached group identities either the U-LOCATION UPDATE DEMAND PDU may include request for attachment/detachment of group identities in the group identity location demand information element or MM may later attach the groups using attach mechanism, see clause 16.8.2. The MS shall not request to append the new LA into the current RA in the request to append LA information element. The information element LA information is not present in the PDU because this is not a forward registration. This shall have PDU priority 6. The location update type information element in the PDU shall be set to "demand location updating". The primitive parameters shall indicate that the address to be appended by the MAC shall be the SSI ((V)ASSI). Timer T351 shall be started.

## d) Temporarily disabled MS:

- a), b) or c) shall apply with the location update type set to "Disabled MS updating" but there shall be no group attachment or reporting signalling. The MS shall remain in the temporarily disabled state (i.e. access to the communication resources shall only remain open for the MM entity). The temporarily disabled state is defined in EN 300 392-7 [11].

If SwMI accepts the registration it shall send a D-LOCATION UPDATE ACCEPT PDU.

For cases a), b), c) and d) upon receipt of the D-LOCATION UPDATE ACCEPT PDU, which shall be received with an MLE-UNITDATA indication primitive, MM shall, if present, extract the MNI of the MS from the address extension information element and check that it is the same as MNI of the MS ITSI and, if that is the case or the MNI is not present, then the MM shall:

NOTE 4: The address extension information element cannot act as safe guard because there is no information element for the ISSI in the PDU.

- stop timer T351;
- extract any ASSI or (V)ASSI from the SSI field. If the U-LOCATION UPDATE DEMAND contained request for attachment/detachment of group identities, the MM shall inspect the group identity location accept information element to find out if the SwMI accepted them. In case the group identity location accept information element is not present in the D-LOCATION UPDATE ACCEPT PDU, the MS shall assume the group attachment/detachment failed. The MS shall treat the failure as equivalent to T353 timer expiry. If the group attachment acknowledgement does not contain explicit group lifetime, then the applied lifetime is outside the scope of the present document. MM shall inform the MLE of ASSI or V(ASSI) and attached group identities with related (V)GSSIs when applicable with an MLE-IDENTITIES request primitive, see clause 16.8. The MS shall immediately change to use the ASSI or (V)ASSI in layer 2 in all subsequent signalling except for the layer 2 acknowledgement for the received D-LOCATION UPDATE ACCEPT PDU, where the SSI used shall be the same as the layer 2 address used to transfer the D-LOCATION UPDATE ACCEPT PDU;
- extract from the PDU, if information elements are present, the information concerning SCCHs and minimum mode (18<sup>th</sup> frame) monitoring, energy saving information, subscriber class and new registered area and pass these to the lower layers in an MLE-INFO request primitive, refer to clauses 16.7.1 and 16.4.9. If the new registered area information element is not present in the PDU, the MS shall consider the current RA to include only the current LA the MS just registered on with no registration timeout. If the new registered area information element is present, then the new RA is that defined by the LAs in the New registered area information element and the LA timer associated with each new LA shall be started (if applicable; i.e. if the LA Timer value is not 111<sub>2</sub>). SwMI shall include the LA into which registration was made in the New registered area information element. The MS MM shall issue an MLE-UPDATE request primitive indicating a registration result of "Success" or "Temporary registration" and the LAs in the RA. MM shall inform the user application that the MS is ready for use by issuing a TNMM-REGISTRATION confirm primitive indicating "success" and containing registration and group attachment/detachment information. Where an energy economy mode has been requested and the MS is not informed of the outcome of this request in the D-LOCATION UPDATE ACCEPT PDU, the information shall be conveyed in a separate D-MM STATUS PDU as described in clause 16.7.1;
- if registration is successful and communication resources were closed, then the MM shall open the communication resources to the other higher layer entities by issuing an MLE-OPEN request primitive. The MLE-OPEN request shall not be issued if the MS has previously been temporarily disabled and not subsequently enabled by the infrastructure. The MM shall inform the user application with TNMM-SERVICE indication issuing that the MS is in service.

In cases b) (new ITSI) and c) (new unexchanged ITSI) the D-LOCATION UPDATE ACCEPT may contain the optional Default group attachment lifetime information element. If the element is not present, the MS shall assume the lifetime "Attachment for next ITSI-Attach required" to be the default lifetime. If the SwMI rejects the registration it shall send a D-LOCATION UPDATE REJECT PDU.

Upon receipt of the D-LOCATION UPDATE REJECT, MM shall, if present, extract the MNI from the address extension information element and check that it is the same as MNI of the MS ITSI and, if that is either the case or the MNI is not present, then MM shall:

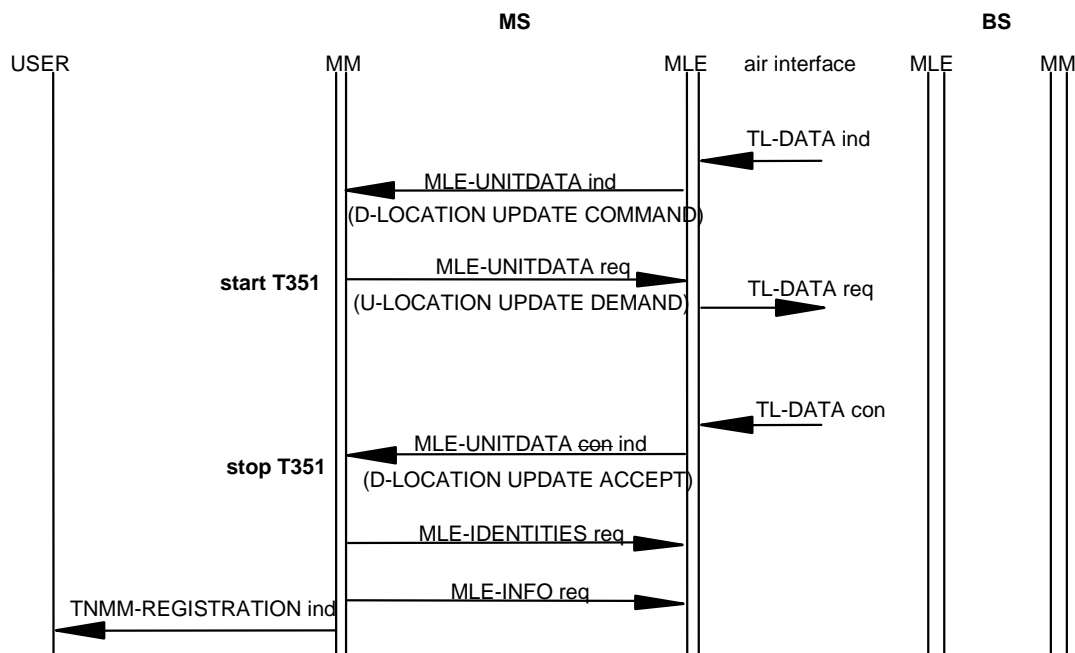
NOTE 5: The address extension information element cannot act as complete safe guard because there is no information element for the ISSI in the PDU.

- stop timers T351 and T352, if started;
- inform the user application about registration failure by issuing a TNMM-REGISTRATION indication primitive containing "failure" and the reject cause;

- analyse the reject cause and act similarly as in normal registration, see clause 16.4.1.1.
- further registration requests can be made in response to the receipt of further TNMM-REGISTRATION requests from the user application, once a new cell has been selected. In the event that the serving cell was the only cell available, MM shall issue an MLE-CLOSE request to the MLE and TNMM-SERVICE indication to the TNMM-SAP indicating that the MS is "out of service". The MM shall consider the MS to be de-registered and hence apply the activation procedure as defined in clause 16.3 in order to get into service again.

NOTE 6: When to apply the activation procedure, after no service is obtained is outside the scope of the present document.

### 16.4.3 Infrastructure initiated registration procedure



NOTE: Infrastructure initiated registration is carried out following information given by the MLE through an MLE-UNITDATA indication.

**Figure 51: Infrastructure initiated registration**

**Figure 52: Void**

**Figure 53: Void**

The SwMI may initiate registration at any time by sending a D-LOCATION UPDATE COMMAND PDU, which may contain a group report request.

Upon receipt of the D-LOCATION UPDATE COMMAND PDU, the MM shall if present, extract the MNI from the address extension information element and check that it is the same as MNI of the MS ITSI and, if that is either the case or the MNI is not present, then MM shall:

- send a U-LOCATION UPDATE DEMAND PDU which shall contain the MNI of the MS in the address extension information element and the ISSI of the MS in the SSI information element, thus providing the true ITSI. This shall have PDU priority 6. The location update type information element in the PDU shall be set to "demand location updating" or "disabled MS updating" depending whether the MS is enabled or disabled. The MLE-UNITDATA request primitive parameters shall indicate that the identity to be used shall be the ASSI/(V)ASSI, if one has been issued, or the ISSI in the case where an ASSI/(V)ASSI has not been issued;

- upon receipt of the D-LOCATION UPDATE COMMAND PDU including a group report request from the MLE, the MM shall regard all the group identities no more attached. If the MS wishes to receive signalling on those group identities, the MM may include group attachments to the U-LOCATION UPDATE DEMAND PDU or re-attach all the groups using U-ATTACH/DETACH GROUP IDENTITY PDUs. If the MS has no groups to attach, it shall send U-LOCATION UPDATE DEMAND PDU containing a group report response information element indicating "group report complete". When sending the first group attachment, either in U-LOCATION UPDATE DEMAND PDU or U-ATTACH/DETACH GROUP IDENTITY PDU, the group identity attach/detach mode information element shall be set to "detach all currently attached group identities and attach group identities defined in the group identity.." and the group identity report information element to "not report request". If all the reported groups are sent in this one PDU it shall contain a group report response information element indicating "group report complete", or otherwise not include this information element. The PDU priority shall be set to 3. Timer T353 shall be started. For further discussion of the use of the U-ATTACH/DETACH GROUP IDENTITY PDU in this context see clause 16.8.3;
- upon receipt of the D-LOCATION UPDATE COMMAND PDU without a group report request, the MM shall assume that group identities with parameter value "Attachment for next location update required" are no more attached. If MS wishes to receive signalling on those group identities either the U-LOCATION UPDATE DEMAND PDU may include request for attachment of those group identities in the group identity location demand information element or MM may later attach the groups using attach mechanism, see clause 16.8.2;
- the U-LOCATION UPDATE DEMAND PDU shall contain the class of MS element;
- the U-LOCATION UPDATE DEMAND PDU shall contain economy mode information in the energy saving mode information element if energy saving is activated, if so timer T352 shall be started;
- the MS shall not request to append the new LA into the current RA in the request to append LA information element. The information element LA information shall not be present in the PDU because this is not a forward registration;
- timer T351 shall be started.

Upon receipt of the D-LOCATION UPDATE ACCEPT PDU MM shall, if present, extract the MNI from the address extension information element and check that it is the same as MNI of the MS ITSI and, if that is either the case or the MNI is not present, then MM shall:

- extract any ASSI or (V)ASSI from the SSI field. The MS shall immediately change to use the ASSI/(V)ASSI in layer 2 in all subsequent signalling except for the layer 2 acknowledgement for the received D-LOCATION UPDATE ACCEPT PDU, where the same SSI shall be used as was used in layer 2 in the D-LOCATION UPDATE ACCEPT PDU;
- if the U-LOCATION UPDATE DEMAND contained request for attachment/detachment of group identities, the MM shall inspect the group identity location accept information element to find out if the SwMI accepted them. In case the group identity location accept information element is not present in the D-LOCATION UPDATE ACCEPT PDU, the MS shall assume the group attachment/detachment failed. The MS shall treat the failure as equivalent to T353 timer expiry. If the group attachment acknowledgement does not contain explicit group lifetime, then the applied lifetime is outside the scope of the present document. MM shall inform the MLE of ASSI or V(ASSI) and accepted and thus attached group identities and related (V)GSSIs with an MLE-IDENTITIES request primitive, see clause 16.8. The MS shall immediately change to use the ASSI or (V)ASSI in all subsequent signalling except for the layer 2 acknowledgement for the received D-LOCATION UPDATE ACCEPT PDU, where the SSI used shall be the same as in D-LOCATION UPDATE ACCEPT PDU;
- stop timer T351;
- MM shall, if information elements are present, extract from the PDU the information concerning SCCHs and minimum mode (18th frame) monitoring, energy saving information, subscriber class and new registered area information and inform these to the lower layers in an MLE-INFO request primitive, refer to clause 16.7.1 and 16.4.9. If the new registered area information element is not present in the PDU, the MS shall consider the current RA to include only the current LA the MS just registered on with no registration timeout. If the new registered area information element is present, then the new RA is that defined by the LAs in the New registered area information element and the LA timer associated with each LA shall be started. The LA into which the registration was made shall be included in the New registered area information element;

- the MS MM shall issue an MLE-UPDATE request primitive indicating a registration result of "Success" or "Temporary registration" and the LAs in the RA. MM shall inform the user application about infrastructure initiated registration by issuing a TNMM-REGISTRATION indication primitive containing registration and group attachment/detachment information.
- If the SwMI rejects the registration it shall send a D-LOCATION UPDATE REJECT PDU.

Upon receipt of a D-LOCATION UPDATE REJECT, MM shall, if present, extract the MNI from the address extension information element and check that it is the same as MNI of the MS ITSI and, if that is either the case or the MNI is not present, then MM shall:

NOTE 1: The address extension information element cannot act as complete safe guard because there is no information element for the ISSI in the PDU.

- stop and reset timer T351 and T352, if started;
- inform the user application about registration failure by issuing a TNMM-REGISTRATION indication primitive containing "failure" and the reject cause;
- analyse the reject cause and act similarly as in normal registration, see clause 16.4.1.1;
- in the event that the serving cell was the only cell available, MM shall issue an MLE-CLOSE request to the MLE and TNMM-SERVICE indication to the TNMM-SAP indicating that the MS is "out of service". The MM shall consider the MS to be de-registered and hence apply the activation procedure as defined in clause 16.3 in order to get into service again.

NOTE 2: When to apply the activation procedure after no service is obtained is outside the scope of the present document.

#### 16.4.4 Colliding registrations

In the event that the MS MM requests registration at the same time that the infrastructure demands that the MS MM registers, the MS MM should respond to the D-LOCATION UPDATE COMMAND PDU using the procedure defined in clause 16.4.3. On successful outcome, MM shall inform the user application with a TNMM-REGISTRATION indication containing registration and group attachment/detachment information.

#### 16.4.5 Expiry of timer T351

This timer is intended to control how often an MS may try to register to a BS. On the expiry of timer T351, if it is still possible to solely cancel the outstanding PDU according to clause 16.3.1.3, MM shall issue an MLE-CANCEL request with the handle of the transmission request it corresponds to.

If it is no longer possible to solely cancel the outstanding PDU according to clause 16.3.1.3, MM may issue a U-ITSI DETACH PDU using the de-registration procedures described in clause 16.6 or resend the U-LOCATION UPDATE DEMAND PDU using the procedures described in clauses 16.4.1 and 16.4.2. The MS may wish to select a new serving cell before further registration attempts should be made.

#### 16.4.6 Expiry of LA timers

The LA timer is intended to clear out LAs from the current RA. LA timer shall be mandatory for MS. If SwMI utilises optional LA timer and it expires in the SwMI it may no more page the MS on that LA. The optional LA timer in SwMI should have a longer timeout value than the value attached to the MS. If a LA timer expires and the LA is not the current LA, then the LA shall be removed from the current RA in the MS and the MM shall issue an MLE-UPDATE request primitive to the MLE containing the valid LAs of the RA. If a LA timer expires and the LA is the current LA, MM shall inform user application by sending a TNMM-REGISTRATION indication with registration parameter set to "LA registration expired" and LA parameter to the current LA so that the application could initiate registration in a suitable time e.g. after completing on-going call as defined in clause 16.4.2 a).



## 16.4.7 Lifetime of ASSI/(V)ASSI

Only one alias SSI (ASSI or (V)ASSI) shall be valid per ITSI at one time. When the SwMI allocates a new ASSI or VASSI to MS (ITSI), the previous ASSI or (V)ASSI becomes invalid.

If SwMI allocates ISSI of the MS as ASSI, the previous ASSI, if any, becomes invalid.

Once ASSI or (V)ASSI has been allocated, MS shall use it as defined in clause 23.4.1.2.1 and 23.4.1.2.2. Even if ASSI has been allocated, SwMI may send PDUs using ISSI in home network (refer to clause 23.4.1.2.1, note 4) in which case the layer 2 acknowledgement sent by MS shall contain ISSI.

### 16.4.7.1 ASSI/(V)ASSI validity at migration

The ASSI/(V)ASSI is valid only within the SwMI which allocated it. When MS migrates (i.e. MS sends location update with type "migrating location updating" or "call restoration migrating location updating") the previous ASSI/(V)ASSI becomes invalid and the migrated to SwMI shall allocate a new (V)ASSI or may allocate an ASSI as appropriate.

### 16.4.7.2 ASSI/(V)ASSI validity by MS initiative

Whenever MS makes an "ITSI Attach" registration attempt (either successful or unsuccessful), the current ASSI, if any, becomes invalid. Whenever MS makes de-registration (sends U-ITSI DETACH PDU), the current ASSI/(V)ASSI, if any, becomes invalid.

### 16.4.7.3 ASSI/(V)ASSI validity at registration rejection

If SwMI rejects the registration attempt either with reason "Migration not supported", "ITSI/ATSI unknown" or "Illegal MS", the current ASSI/(V)ASSI, if any, shall become invalid. With any other reject reason the ASSI/(V)ASSI remains valid.

NOTE 1: It is useful not to withdraw the ASSI / (V)ASSI in every case when registration is rejected. For example in case the SwMI rejects the registration attempt because the LA is not allowed for the MS, the MS may send next registration (to some other LA) using the ASSI/(V)ASSI and thus not revealing its own identity (ISSI). However, in case SwMI wants to reject visiting MS permanently the (V)ASSI shall be withdrawn.

NOTE 2: There are no means for SwMI to withdraw the ASSI explicitly within registration rejection because D-LOCATION UPDATE REJECT PDU does not contain ASSI/(V)ASSI information element.

## 16.4.8 Temporary registration

In case the status of the BS changes from "normal mode" to "system wide services temporarily not supported " the MSs which have already registered there stay normally registered (no action needed).

In case MS registers to a BS which is in state "system wide services temporarily not supported" and gets a registration accepted response with status "Temporary registration", the MS shall consider its registration to be temporarily accepted in the system. The MM shall pass this "Temporary registration" information to MLE within "Registration status" parameter in MLE-UPDATE request.

NOTE 1: In "system wide services temporarily not supported " state, the SwMI may either accept the registration normally or use the "temporary registration" acknowledgement.

In case the status of the BS changes from "system wide services temporarily not supported " to "normal mode" the MSs which have received a "Temporary registration" response have to register again (with type "periodic location updating"). The MLE shall detect the change to normal mode and shall indicate the need for periodic registration to MM by sending MLE-LINK indication. Those MSs that have received a normal registration accept acknowledgement shall not register again.

In case MS, which has received a "Temporary registration" acknowledgement, makes a cell reselection it has to register to the new cell even if the cell belongs to the Registered area of the MS. In this case MLE shall indicate the need for registration to MM by sending MLE-LINK indication.

NOTE 2: SwMI should use the "Temporary registration" acknowledge only in case the BS is in state "system wide services temporarily not supported ".

## 16.4.9 Subscriber class procedures

Upon reception of a D-LOCATION UPDATE ACCEPT PDU which contains the subscriber class information element the MM shall:

- if a network provides a subscriber class profile in the subscriber class information element, this overrides any previous subscriber class information previously supplied for this network (at subscription or earlier registration) and the MS will inform this to MLE in an MLE-INFO request primitive as defined registration protocols;
- if the home network provides no subscriber class information in a subscriber class information element, the MS will use the subscriber class profile allocated at subscription;
- if a visited network provides no subscriber class information in a subscriber class information element, the MS shall assume that all subscriber classes are valid.

NOTE: A subscriber class profile is valid only within the network which allocated it.

Upon receiving MLE-INFO indication indicating no match between the subscriber class being broadcast by the SwMI and the subscriber class of the MS, the MM shall respond to all SwMI initiated procedures normally but shall restrict the MS initiated requests so that only the next procedures are allowed:

- location updating;
- de-registration;
- security related procedures described in EN 300 392-7 [11].

All the other MS initiated procedures are rejected and MM shall send a failure report to the SAP and the user application should assume that the requested service has failed.

## 16.4.10 Frequency band capability procedures

After reception of a D-LOCATION UPDATE ACCEPT PDU the MS may send a U-MM STATUS PDU carrying a U-MS FREQUENCY BANDS INFORMATION PDU to inform which frequency bands it supports.

The SwMI may at any time send a D-MM STATUS PDU carrying a D-MS FREQUENCY BANDS REQUEST PDU. When receiving this PDU the MS should respond with sending a U-MM STATUS PDU carrying a U-MS FREQUENCY BANDS INFORMATION PDU to inform which frequency bands it supports. In addition MS should re-send the U-MS FREQUENCY BANDS INFORMATION at the occasions specified in the "Re-send interval" element of the D-MS FREQUENCY BANDS REQUEST PDU.

The frequency of the lower and upper edge carrier shall be defined by the following information elements:

- lower/upper edge carrier;
- lower/upper edge frequency band;
- duplex spacing;
- reverse operation.

The upper/lower edge frequency band field shall map to a specific frequency which shall map to a defined base frequency (in MHz) for the carrier numbering scheme. The lower/upper edge carrier field shall indicate the carrier frequency relative to the base frequency defined by the corresponding frequency band field. The frequency so defined shall be the approximate downlink frequency of the lower/upper carrier. This calculation shall be summarized by the following equation:

- $\text{downlink lower/upper edge carrier frequency} = \text{base frequency} + (\text{upper/lower edge carrier} * 25 \text{ kHz}).$

The uplink frequency of the lower/upper edge carrier shall be determined using the duplex spacing and reverse operation fields. The duplex spacing field shall map to a defined duplex spacing (in MHz) for the carrier numbering scheme. The duplex spacing shall be dependent on the frequency band element. The reverse operation field shall indicate whether to add or subtract the duplex spacing to arrive at the uplink frequency of the main carrier. If normal operation, the duplex spacing shall be subtracted. If reverse operation, the duplex spacing shall be added. This calculation is summarized by the following equations:

- normal operation:
  - uplink upper/lower edge carrier frequency = downlink main carrier frequency - duplex spacing.
- reverse operation:
  - uplink upper/lower edge carrier frequency = downlink main carrier frequency + duplex spacing.

The mapping of the frequency band field values to actual base frequencies and the duplex spacing field values to actual duplex frequency spacing are defined in annex F.

NOTE 1: These rules for calculation of uplink and downlink carrier frequency are also used for calculation of the carrier frequency in clause 21 with an exception of the offset.

NOTE 2: An MS may support a frequency range which may be larger or smaller than the actual frequency allocation defines in each country.

SwMI actions due to this information are outside the scope of the present document.

### 16.4.11 Air to ground reporting procedure

The SwMI may at any time send a D-MM STATUS PDU carrying a D-DISTANCE REPORTING REQUEST PDU. If the MS supports this optional procedure it shall upon reception of the D-DISTANCE REPORTING REQUEST PDU start the reporting timer with value defined by the Distance reporting timer information element. If the value is "No reporting / stop reporting" the MS shall not start or continue reporting.

While the MS is starting transmission for any reason it shall stop the reporting timer and upon ceasing the transmission MS shall start the reporting timer, refer to clause 16.4.

Upon expiry of the reporting timer the MS shall send a Null PDU unless there is something else already waiting for sending.

After each location update the MS shall check, whether the reporting is to be continued based on the distance reporting validity.

NOTE 1: The protocol model supports various implementation possibilities:

- the MM sends null PDUs to the lower layers at reporting intervals and the MAC layer may send the null PDUs without taking into account any other transmissions or the MAC may discard sending of the Null PDU when it has some else to be sent at the time the Null PDU is due to sending. In those options a usage of the MLE-CONFIGURE request primitive is not needed;
- the MM informs the MAC layer by the MLE-CONFIGURE request primitive the periodic reporting timer value and the MAC layer manages the sending of the Null PDUs. In that case the MM need not send Null PDUs.

If the MS does not support this procedure it should response to the D-DISTANCE REPORTING REQUEST PDU by a U- MM PDU/FUNCTION NOT SUPPORTED PDU as defined in clause 16.8.8.

NOTE 2: There is no MM protocol confirmation that the MS has accepted the distance reporting request.

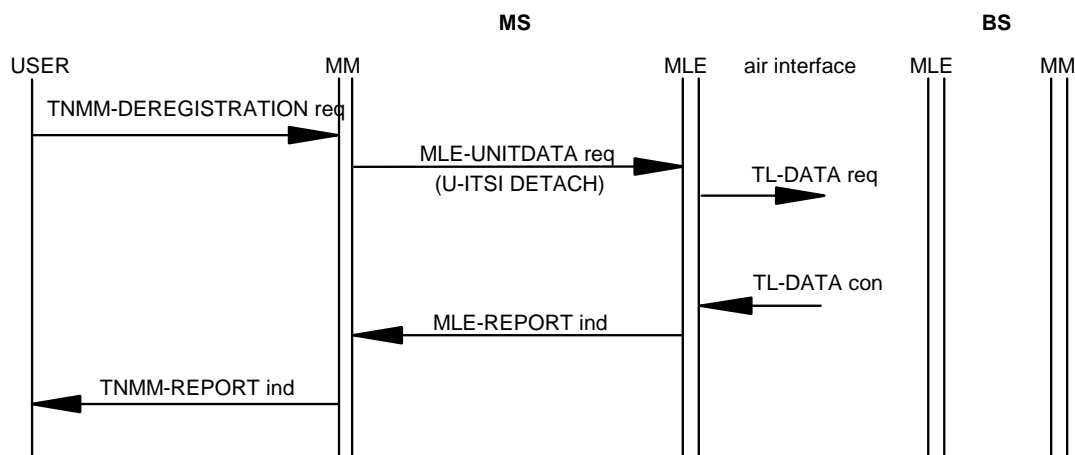
## 16.5 Enable and disable procedures

MS enable and disable utilises MM procedures, refer to EN 300 392-7 [11] clause 5.

## 16.6 De-registration procedure

### 16.6.1 Trunking mode de-registration

The de-registration procedure need not be applied. Examples of where the user application may request de-registration can be at power down, or if the user specific information, including the ITSI, is removed from the TE.



**Figure 54: De registration of MS (detach)**

Upon receipt of a TNMM-DEREGISTRATION request primitive from the user application the MS MM shall send a U-ITSI DETACH PDU to the MLE with an MLE-UNITDATA request primitive. This shall have PDU priority 3. MM may include the MNI of the MS in the address extension information element the U-ITSI DETACH PDU.

**NOTE:** The address extension information element cannot act as complete safe guard because there is no information element for the ISSI in the PDU

Upon receipt of the MLE-REPORT indication indicating that the U-ITSI DETACH PDU has been successfully or unsuccessfully transmitted by the DLL, MM shall inform the user application of this by issuing a TNMM-REPORT indication primitive.

A MS in the temporarily disabled state shall remain in this state after de-registration. The temporarily disabled state is defined in EN 300 392-7 [11].

### 16.6.2 Direct mode related de-registration

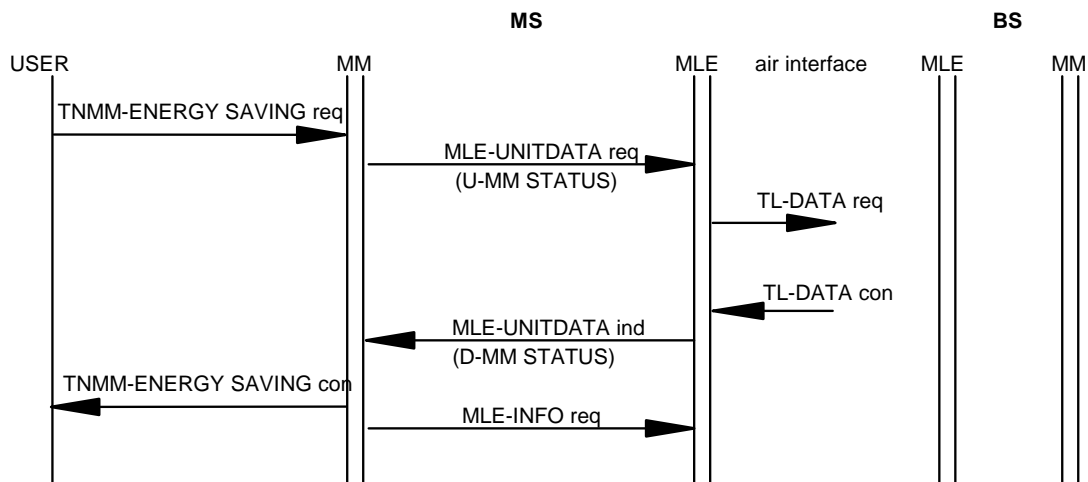
MS station may optionally inform SwMI that it leaves trunking mode and goes to direct mode operation without dual watch operation and in effect will be no more reachable in the trunking mode.

Upon reception TNMM-STATUS request primitive with value "Start of direct mode operation" MS shall inform SwMI that it is leaving to direct mode operation by sending a U-MM STATUS PDU with status "Start of direct mode operation" in a MLE-UNITDATA request PDU. The information element DMO carrier may indicate the DMO RF channel to which MS is moving for direct mode operation and the information elements start of direct mode operation cause and mode change information may provide further information. The PDU shall use PDU priority 3. MM should wait for a MLE-REPORT indication before leaving trunking mode.

Return to trunking mode operation shall use appropriate registration such as user application initiated periodic registration or MLE initiated registration in case the MS has camped on a new cell outside the current RA.

## 16.7 Energy economy

### 16.7.1 Energy economy mode procedure



**Figure 55: Change energy economy mode**

MS shall initiate this procedure upon receipt of a TNMM-ENERGY SAVING request primitive and the MS MM shall issue an MLE-UNITDATA request primitive with a U-MM STATUS PDU carrying U-CHANGE OF ENERGY SAVING MODE REQUEST sub-PDU to the infrastructure to request a specific energy economy mode. This PDU shall have PDU priority 1. Timer T352 shall be started. The MS shall inform MAC that no energy economy mode is applicable by sending an MLE-INFO request primitive with value "stay alive".

The energy economy mode may also be requested at registration using U-LOCATION UPDATE DEMAND PDU as defined in clauses 16.4.1.1, 16.4.1.2, 16.4.2 and 16.4.3. The BS may respond to this by either normal registration PDU or after registration by a D-MM STATUS PDU carrying a D-CHANGE OF ENERGY SAVING MODE RESPONSE sub-PDU.

Upon receipt of a D-MM STATUS PDU carrying a D-CHANGE OF ENERGY SAVING MODE RESPONSE sub-PDU or a D-LOCATION UPDATE ACCEPT PDU containing an energy saving information element, timer T352 shall be stopped and MM shall:

- if the received information element energy saving mode has another value than "stay alive" MM shall inform the lower layers of the energy economy parameters in an MLE-INFO request primitive. The energy economy parameters are in the energy economy mode configuration parameter, which shall contain the energy saving mode and energy economy start point, the latter shall define the absolute frame and multiframe number of the start point. MM shall inform the user application the start of the energy saving mode and its value with a TNMM-ENERGY SAVING confirm primitive;

NOTE 1: The BS may allocate a different energy saving mode than requested and the BS assumes that the allocated value will be used.

- if the received information element energy saving mode has value "stay alive" MM shall inform the user application with a TNMM-ENERGY SAVING confirm primitive by setting the energy economy mode status parameter value to "rejected" (except in the case of a request to stay alive) and the energy economy mode parameter value to "stay alive".

NOTE 2: If the BS rejected the energy saving mode the MS may try to invoke energy saving mode upon next registration.

BS may change (i.e. modify or stop) or allocate an energy saving mode of an MS at any time by sending a D-MM STATUS PDU carrying a D-CHANGE OF ENERGY SAVING MODE REQUEST sub-PDU.

Upon reception of the D-MM STATUS PDU carrying the D-CHANGE OF ENERGY SAVING MODE REQUEST sub-PDU the MS shall respond to the allocation by sending a U-CHANGE OF ENERGY SAVING MODE RESPONSE PDU. In the response the MS shall use the same energy saving mode value as in the D-CHANGE OF ENERGY SAVING MODE REQUEST sub-PDU or reject the allocation by using energy saving mode value "stay alive". The MM shall inform the user application the start or a change of the energy saving mode and its value with a TNMM-ENERGY SAVING indication primitive. Energy economy mode may be applicable to a MS in the temporarily disabled state.

MM shall assume that the energy economy mode is lost when RA is changed, and the MS will then need to re-request an energy economy mode if it wishes to apply energy saving.

## 16.7.2 Procedures for requesting Direct Mode dual watch operation

### 16.7.2.1 Introduction

Dual watch may be performed by an MS that is capable of both V+D and TETRA Direct Mode operation (see ETS 300 396-3 [35]). A full dual watch MS is capable of periodically receiving the V+D common control channel while in a Direct Mode call, a Direct Mode RF carrier while in a V+D call and, when idle, it periodically receives both the Direct Mode RF carrier and the V+D common control channel. In order for the MS to periodically receive the V+D common control channel while in a Direct Mode call, the MS needs to negotiate with the SwMI to use a periodic reception procedure similar to energy economy mode with an appropriate energy economy group.

An MS supporting idle dual watch is capable of periodically receiving both the Direct Mode RF carrier and the V+D common control channel when idle. The MS may not be capable of receiving the V+D common control channel while in a Direct Mode call or a Direct Mode RF carrier while in a V+D call. An MS may be forced to operate in idle dual watch mode in the case that the MS cannot negotiate a satisfactory energy economy mode with the SwMI or it may be totally dependent on the capabilities of the MS. When requesting idle dual watch mode, the MS may negotiate with the SwMI to use a periodic reception procedure similar to energy economy mode. When the MS requests direct mode dual watch operation, it indicates whether it is requesting full dual watch or idle dual watch by using the "dual watch mode" information element of the U-DUAL WATCH MODE REQUEST sub-PDU.

**NOTE:** SwMI designers should see note that also a full dual watching MS will not always be able to receive in the V+D slots corresponding to the agreed energy economy group and, even if the MS receives a V+D message, it may not always be able to send a layer 3 response e.g. if it is currently in a Direct Mode call. Also, the MS sometimes may not be able to send even a layer 2 response e.g. if it is currently in an emergency Direct Mode call. Therefore, if a dual watching MS does not respond to any V+D messages, the SwMI should not assume that the MS has left the V+D network unless the MS fails to transmit or respond to V+D messages over a long period of time. This time may be longer for an MS that is using idle dual watch mode.

The MS shall inform the SwMI when it wishes to start or resume full dual watch operation with an appropriate energy economy group, when it wishes to change the energy economy group associated with its full dual watch operation and when it wishes to stop full dual watch operation. The MS may inform the SwMI when it wishes to start or resume idle dual watch operation and shall inform the SwMI when it wishes to change the energy economy group associated with its dual watch operation; also, if the MS informed the SwMI when it started or resumed idle dual watch operation then it shall inform the SwMI when it wishes to stop idle dual watch operation. The procedures defined in the remainder of this clause, and in clauses 16.7.2.2 to 16.7.2.6, relate to the full dual watching procedure; they relate also to the idle dual watching procedure in the case when the MS informs the SwMI that it is performing idle dual watch. Clause 16.7.2.7 describes the idle dual watching procedure in the case when the MS does not inform the SwMI that it is performing idle dual watch.

When the MS wishes to start or resume full or idle dual watch operation with an appropriate energy economy group, or when it wishes to start or resume idle dual watch operation without using an energy economy group, or when it wishes to change the energy economy group associated with its dual watch operation, it uses a U-MM STATUS PDU carrying a U-DUAL WATCH MODE REQUEST sub-PDU (see clause 16.7.2.2). When the MS wishes to stop dual watch operation, it uses a U-MM STATUS PDU carrying a U-TERMINATING DUAL WATCH MODE REQUEST sub-PDU (see clause 16.7.2.3).

When the MS is in dual watch mode, the SwMI may at any time change the energy economy group associated with the MS's dual watch operation or withdraw its acceptance of the MS's dual watch request by sending a D-MM STATUS PDU carrying a D-CHANGE OF DUAL WATCH MODE REQUEST sub-PDU (see clause 16.7.2.4).

### 16.7.2.2 MS requesting to start, modify or resume dual watch mode

Upon receipt of a TNMM-STATUS request primitive with the "dual watch" parameter value set to "starting dual watch mode" or "modify or resume dual watch mode", the MS MM shall issue an MLE-UNITDATA request primitive with a U-MM STATUS PDU carrying a U-DUAL WATCH MODE REQUEST sub-PDU. If the MS is requesting full dual watch mode, the MM shall set the "energy saving mode" information element to request an appropriate energy economy group. If the MS is requesting idle dual watch mode, it may include a request for an energy economy group in the PDU; alternatively it may set the "energy saving mode" information element to "stay alive". MM shall set the "dual watch mode" information element according to the MS capabilities.

The U-DUAL WATCH MODE REQUEST sub-PDU shall have PDU priority 3. When MM sends the PDU, timer T352 shall be started and MM shall instruct the MAC to "stay alive" by issuing an MLE-INFO request primitive.

On receiving a D-MM STATUS PDU carrying a D-DUAL WATCH MODE RESPONSE sub-PDU, timer T352 shall be stopped and MM shall perform the following procedure a), b), c) or d) as appropriate:

- a) If the MS requested for full dual watch and the "result of dual watch request" information element indicates "Request accepted ..." and the received information element "energy saving mode" has a value appropriate for full dual watch, MM shall inform the lower layers of the dual watch parameters in an MLE-INFO request primitive. The dual watch parameters are in the "dual watch mode configuration" parameter, which shall contain the energy saving mode and the starting frame and multiframe. The energy saving mode shall define the dual watch energy economy group and the frame number and multiframe number shall define the dual watch start point. The D-DUAL WATCH MODE RESPONSE sub-PDU may contain the "SCCH information and distribution on 18th frame" information element, in which case MM shall include the information concerning SCCHs and minimum mode configuration in the MLE-INFO request primitive. MM shall inform the user application of the acceptance of the dual watch and the value of the energy saving mode with a TNMM-STATUS confirm primitive.

NOTE 1: The SwMI may allocate a different energy saving mode than requested and the SwMI assumes that the allocated value will be used. However, the SwMI should not allocate a value of energy saving mode that is not appropriate for full dual watch operation (as defined in ETS 300 396-3 [35], EN 300 396-4 [36] and EN 300 396-7 [38]).

NOTE 2: For a dual watch activation:

- the SwMI should assign a starting point to a full dual watching MS such that the MS's reception cycle includes V+D frame 18;
- the SwMI may need to include the "SCCH information and distribution on 18th frame" information element in the D-MM STATUS PDU because it should assign the same common control channel to all full dual watching MSs on the same direct mode RF carrier on a cell.

This allows MSs to maintain V+D synchronization and enables compatible cycles for all full dual watching MSs on a Direct Mode RF carrier.

- b) If the MS requested for full dual watch and the "result of dual watch request" information element indicates "Request accepted ..." but the received information element "energy saving mode" has a value not appropriate for full dual watch, MM may either convert to idle dual watch procedures or abandon the dual watch mode completely.

If the MS converts to idle dual watch mode, MM shall inform the lower layers of the dual watch parameters in an MLE-INFO request primitive. The dual watch parameters are in the "dual watch mode configuration" parameter, which shall contain the energy saving mode and the starting frame and multiframe. The energy saving mode shall define the dual watch energy economy group and the frame number and multiframe number shall define the dual watch start point. The D-DUAL WATCH MODE RESPONSE sub-PDU may contain the "SCCH information and distribution on 18th frame" information element, in which case MM shall include the information concerning SCCHs and minimum mode configuration in the MLE-INFO request primitive. MM shall inform the user application of the offered idle dual watch and the value of the energy saving mode with a TNMM-STATUS confirm primitive.

NOTE 3: If the SwMI cannot support an energy saving mode appropriate for full dual watch mode, the SwMI should not reject the dual watch request but offer a different energy saving mode or no energy saving mode ("stay alive") to the MS. This allows the MS to perform idle dual watch procedures. If the SwMI allocates a value of energy saving mode that is not appropriate for full dual watch operation, the SwMI should assume that the MS is only capable of the idle dual watch procedure.

If the user application abandons the offered idle dual watch mode it may either stay in V+D mode or go totally to direct mode. If the MS wishes to stay in V+D mode, the MM shall send a U-MM STATUS PDU carrying a U-TERMINATING DUAL WATCH MODE REQUEST sub-PDU (see clause 16.7.2.3). If MS wants to go to the direct mode, the MM may send a U-MM STATUS PDU carrying a U-START OF DIRECT MODE OPERATION sub-PDU (see clause 16.6.2).

- c) If the MS requested for idle dual watch and the "result of dual watch request" information element indicates "Request accepted ...", MM shall inform the lower layers of the dual watch parameters in an MLE-INFO request primitive. The dual watch parameters are in the "dual watch mode configuration" parameter, which shall contain the energy saving mode and the starting frame and multiframe. The energy saving mode shall define the dual watch energy economy group and the frame number and multiframe number shall define the dual watch start point. The D-DUAL WATCH MODE RESPONSE sub-PDU may contain the "SCCH information and distribution on 18th frame" information element, in which case MM shall include the information concerning SCCHs and minimum mode configuration in the MLE-INFO request primitive. MM shall inform the user application of the acceptance of the idle dual watch and the value of the energy saving mode with a TNMM-STATUS confirm primitive.

NOTE 4: The SwMI may allocate a different energy saving mode than requested and the SwMI assumes that the allocated value will be used.

NOTE 5: If the SwMI cannot support the requested energy saving mode, the SwMI should not reject the dual watch request but offer a different energy saving mode or no energy saving mode ("stay alive") to the MS. An MS is able to perform idle dual watch procedures with a different energy saving mode or with no energy saving mode.

- d) If the "result of dual watch request" information element indicates "Request rejected for undefined reason" or "Dual watch not supported", MM shall inform the user application of the rejection of the dual watch request with a TNMM-STATUS confirm primitive with the "dual watch" parameter value set appropriately and the "energy economy mode" parameter value set according to received "energy saving information" information element.

If the SwMI rejects the dual watch request then the user application may choose to leave V+D operation and go to Direct Mode operation, or remain in V+D operation, or use the idle dual watching procedure described in clause 16.7.2.7. If the MS leaves V+D operation and goes to Direct Mode operation then the MM may send a U-MM STATUS PDU carrying a U-START OF DIRECT MODE OPERATION sub-PDU (see clause 16.6.2). If the MS remains in V+D operation then the user application may choose to request normal energy economy mode, as defined in clause 16.7.1. The MS may try to request dual watch again after its next registration.



### 16.7.2.3 MS terminating dual watch mode

Upon receipt of a TNMM-STATUS request primitive with the "dual watch" parameter value set to "terminating dual watch mode", the MS MM shall issue an MLE-UNITDATA request primitive with a U-MM STATUS PDU carrying a U-TERMINATING DUAL WATCH MODE REQUEST sub-PDU containing the "energy saving mode" information element set to "stay alive". This PDU shall have PDU priority 3. Timer T352 shall be started. MM shall instruct the MAC to "stay alive" by issuing an MLE-INFO request primitive.

On receiving a D-MM STATUS PDU carrying a D-TERMINATING DUAL WATCH MODE RESPONSE sub-PDU, timer T352 shall be stopped and MM shall inform the user application with a TNMM-STATUS confirm primitive with the "dual watch" parameter value set to "terminating dual watch mode response" and the "energy economy mode" parameter value set to "stay alive".

NOTE: The procedure if the MS wishes to start normal energy economy mode when it terminates dual watch mode is described in clause 16.7.2.5 b).

### 16.7.2.4 SwMI modifying or terminating dual watch mode

If an MS in dual watch mode receives a D-MM STATUS PDU carrying a D-CHANGE OF DUAL WATCH MODE REQUEST sub-PDU, the MS MM shall respond to the PDU by sending a U-MM STATUS PDU carrying a U-CHANGE OF DUAL WATCH MODE RESPONSE sub-PDU. In the response the MS shall use the same "energy saving mode" value as in the D-CHANGE OF DUAL WATCH MODE REQUEST sub-PDU.

If the "reason for dual watch change by SwMI" information element contains value "change of dual watch energy economy group" then the MS shall perform procedure a) or b) as appropriate:

- a) If the MS performs full dual watch and the received "energy saving information" information element contains a value appropriate for full dual watch, or the MS performs idle dual watch, MM shall inform the lower layers of the modified dual watch parameters in an MLE-INFO request primitive. MM shall inform the user application of the modified value of the energy saving mode with a TNMM-STATUS indication primitive.
- b) If the MS performs full dual watch and the received "energy saving information" information element contains a value not appropriate for full dual watch, MM may either convert to idle dual watch procedures or abandon the dual watch mode completely.

If the MS converts to idle dual watch mode, MM shall inform the lower layers of the modified dual watch parameters in an MLE-INFO request primitive. MM shall inform the user application of the change to idle dual watch and the modified value of the energy saving mode with a TNMM-STATUS primitive.

If the user application abandons the offered idle dual watch mode it may either stay in V+D mode or go totally to direct mode. If the MS wishes to stay in V+D mode, the MM shall send a U-MM STATUS PDU carrying a U-TERMINATING DUAL WATCH MODE REQUEST sub-PDU (see clause 16.7.2.3). If MS wants to go to the direct mode, the MM may send a U-MM STATUS PDU carrying a U-START OF DIRECT MODE OPERATION sub-PDU (see clause 16.6.2).

NOTE 1: If the SwMI allocates a value of energy saving mode that is not appropriate for full dual watch operation, the SwMI should assume that the MS is only capable of the idle dual watch procedure.

NOTE 2: In the case that the user application abandons the offered idle dual watch mode, the MM is not allowed to respond to the D-CHANGE OF DUAL WATCH MODE REQUEST PDU by sending a U-TERMINATING DUAL WATCH MODE REQUEST sub-PDU or U-START OF DIRECT MODE OPERATION sub-PDU without first sending U-CHANGE OF DUAL WATCH MODE RESPONSE sub-PDU.

If the "reason for dual watch change by SwMI" information element contains value "dual watch terminated for undefined reason" then MM shall inform the user application of the termination of dual watch mode by issuing a TNMM-STATUS indication primitive and shall instruct the MAC to "stay alive" by issuing an MLE-INFO request primitive. The user application may choose to leave V+D operation and go to Direct Mode operation, or remain in V+D operation, or use the idle dual watching procedure described in clause 16.7.2.7. If the MS leaves V+D operation and goes to Direct Mode operation then the MM may send a U-MM STATUS PDU carrying a U-START OF DIRECT MODE OPERATION sub-PDU (see clause 16.6.2). If the MS remains in V+D operation then the user application may choose to request normal energy economy mode, as defined in clause 16.7.1. The MS may try to request dual watch again after its next registration.

If an MS not in dual watch mode receives a D-MM STATUS PDU carrying a D-CHANGE OF DUAL WATCH MODE REQUEST sub-PDU, the MS MM shall respond to the PDU by sending a U-MM STATUS PDU carrying a U-CHANGE OF DUAL WATCH MODE RESPONSE sub-PDU with the "energy saving mode" value set to "stay alive". This requirement applies only for an MS capable of dual watch operation.

### 16.7.2.5 Changing between modes

An MS cannot operate in both normal energy economy mode and dual watch mode at one time. If the MS wishes to change from one mode to the other mode, it shall perform procedure a) or b) as appropriate:

- a) If an MS in energy economy mode receives a TNMM-STATUS request primitive with the "dual watch" parameter value set to "starting dual watch mode" then it needs to send only a U-MM STATUS PDU carrying a U-DUAL WATCH MODE REQUEST sub-PDU requesting to start dual watch mode (without first sending a PDU requesting to end energy economy mode). The procedure shall be as defined in clause 16.7.2.2.
- b) If an MS in dual watch mode receives a TNMM-ENERGY SAVING request primitive indicating a request to start energy economy mode then it shall send a U-MM STATUS PDU carrying a U-TERMINATING DUAL WATCH MODE REQUEST sub-PDU containing the "energy saving mode" information element set to the value requested for the energy economy mode. This PDU shall have PDU priority 3. Timer T352 shall be started. The procedure on receiving a D-MM STATUS PDU carrying a D-TERMINATING DUAL WATCH MODE RESPONSE sub-PDU shall then be as defined in clause 16.7.1 for receipt of a D-MM STATUS PDU carrying a D-CHANGE OF ENERGY SAVING MODE RESPONSE sub-PDU.

At the time of sending the PDU requesting the new mode, MM shall instruct the MAC to end the old reception cycle by issuing an MLE-INFO request primitive for the old mode indicating "stay alive". Then, if it receives a PDU accepting its request, MM shall inform the MAC of the new parameters by issuing an MLE-INFO request primitive for the new mode.

### 16.7.2.6 General dual watch procedures

Dual watch mode may be applicable to an MS in the temporarily disabled state.

NOTE 1: An enable or disable applied to a subscription or an equipment in V+D will also apply in Direct Mode and vice versa (see EN 300 392-7 [11] and EN 300 396-6 [37]).

Thus, if a dual watching MS receives a disable message on either V+D or Direct Mode then that disable message applies to both V+D and Direct Mode. In the case of a temporary disablement, the MS should then continue to receive both the V+D control channel and the Direct Mode RF carrier, looking for an enable message i.e. an appropriate V+D MM message or Direct Mode SDS message (if supported); during this time, the MS may continue to use the dual watch periodic reception procedure on the V+D control channel. If the MS receives an enable message on either V+D or Direct Mode then that enable message applies to both V+D and Direct Mode.

MM shall assume that the dual watch mode is lost when the RA is changed or if the MS needs to re-register for any reason other than for a periodic registration. Having successfully re-registered, the MS then needs to send again the U-MM STATUS PDU carrying a U-DUAL WATCH MODE REQUEST sub-PDU if it wishes to resume dual watch operation.

NOTE 2: Unlike normal energy economy mode (see clause 16.7.1), the MS cannot use the U-LOCATION UPDATE DEMAND PDU to request dual watch operation.

Both in full and idle dual watch mode the MS may not be able to receive the V+D common control channel while in a Direct Mode call, see clause 23.7.7. It is assumed that in both modes, when the MS is participating in a V+D call or packet data transfer, it shall receive all the required V+D slots.

An idle dual watching MS shall obey the normal criteria for registration as if it had been receiving the V+D common control channel throughout Direct Mode calls in which it participates. So, at the end of a Direct Mode call, the MS is not required to re-register unless the RA has changed or the LA timer has expired (or the MS has received a D-LOCATION UPDATE COMMAND PDU from the SwMI). This applies also to a full dual watching MS.

### 16.7.2.7 Idle dual watch without informing SwMI

The procedures defined in clauses 16.7.2.2 to 16.7.2.6 relate to the full dual watching procedure. They relate also to the idle dual watching procedure, but only in the case when the MS informs the SwMI that it is performing idle dual watch.

Alternatively, upon receipt of a TNMM-STATUS request primitive with the "dual watch" parameter value set to "starting dual watch mode", the MS may perform the idle dual watching procedure without informing the SwMI that it is performing idle dual watch. As in normal idle dual watch, an MS using this form of idle dual watch:

- is capable of periodically receiving both the Direct Mode RF carrier and the V+D common control channel when idle; and
- may not be capable of receiving the V+D common control channel while it is in a Direct Mode call or a Direct Mode RF carrier while it is in a V+D call.

It is assumed that, when the MS is participating in a V+D call or packet data transfer, it shall receive all the required V+D slots.

When performing this form of idle dual watch, the MS shall obey the normal V+D procedures except that it is not required to receive the V+D common control channel while it is in a Direct Mode call.

An MS using this form of idle dual watch shall obey the normal criteria for registration as if it had been receiving the V+D common control channel throughout Direct Mode calls in which it participates. So, at the end of a Direct Mode call, the MS is not required to re-register unless the RA has changed or the LA timer has expired (or the MS has received a D-LOCATION UPDATE COMMAND PDU from the SwMI).

An MS using this form of idle dual watch may choose to request normal energy economy mode, as defined in clause 16.7.1.

This form of idle dual watch mode may be applicable to an MS in the temporarily disabled state. The description in clause 16.7.2.6, see note 1 applies also to this form of idle dual watch.

### 16.7.3 Expiry of timer T352

On the expiry of timer T352, if it is still possible to solely cancel the outstanding PDU according to clause 16.3.1.3, MM shall issue an MLE-CANCEL request with the handle of the transmission request it corresponds to. If it is no longer possible to solely cancel the outstanding PDU according to clause 16.3.1.3, MM shall return a TNMM-ENERGY SAVING or TNMM-STATUS confirm primitive with energy saving mode value "stay alive" and a failure report to the SAP and the user application should assume that the requested service has failed.

## 16.8 Attachment/detachment of group identities and group reporting procedures

The attachment/detachment of group identities procedures are illustrated in figures 56 and 57. Group reporting procedures are illustrated in figures 58 and 59. Attachment/detachment of group identities and group reporting can be initiated by the user application or it can be requested by the infrastructure.

The attached group identities, used as valid layer 2 group addresses, shall be defined as follows:

- 1) attached by the SwMI, by using D-ATTACH/DETACH GROUP IDENTITY PDU and accepted by the MS using the corresponding U-ATTACH/DETACH GROUP IDENTITY ACKNOWLEDGEMENT PDU;
- 2) previously attached group identities if the attachment/detachment mode in the D-ATTACH/DETACH GROUP IDENTITY PDU were an "amendment";
- 3) previously attached group identities which were not detached by the SwMI in the D-ATTACH/DETACH GROUP IDENTITY PDU;
- 4) attachment requested by the MS by using U-ATTACH/DETACH GROUP IDENTITY or U-LOCATION UPDATE DEMAND PDU, and accepted by the SwMI in the corresponding D-ATTACH/DETACH GROUP IDENTITY ACKNOWLEDGEMENT or D-LOCATION UPDATE ACCEPT PDU;
- 5) previously attached group identities if the attachment/detachment mode in the U-ATTACH/DETACH GROUP IDENTITY PDU or U-LOCATION UPDATE DEMAND PDU were an "amendment";
- 6) previously attached group identities which were not detached by the MS by using U-ATTACH/DETACH GROUP IDENTITY or U-LOCATION UPDATE DEMAND PDU;
- 7) defined with the attachment mode "attachment is not needed". This may be defined either by using group identity attachment lifetime information element in the attachment/detachment PDUs or by using other means outside of the scope of the present document;
- 8) defined to be temporary group address, active during a call (see CMCE protocol in clause 14);
- 9) defined and attached by SS-DGNA, refer to EN 300 392-12-22 [46] and not detached by any of the previous actions;
- 10) previously attached group identities whose group identity attachment lifetime is still valid.

The MS shall always use a (V)GSSI as lower layer receiving address instead of the GSSI when the (V)GSSI is assigned for the MS in the currently registered SwMI. GSSI shall not be used as an active group identity if the currently registered network MCC and MNC is not the same as the MCC and MNC related to the GSSI.

In case the MS has been temporarily disabled and then enabled by the SwMI, the MS may assume that the groups that were attached at the time when the temporary disabling was done are still attached if not otherwise defined by the attachment lifetime. However, after enabling the MS shall re-attach the groups having lifetime "Attachment for next location update required" if the MS wishes the groups to remain attached. MS may also re-attach any groups.

Examples of group attachment/detachment message flows are in annex G.

### 16.8.1 Infrastructure initiated attachment/detachment of group identities procedure

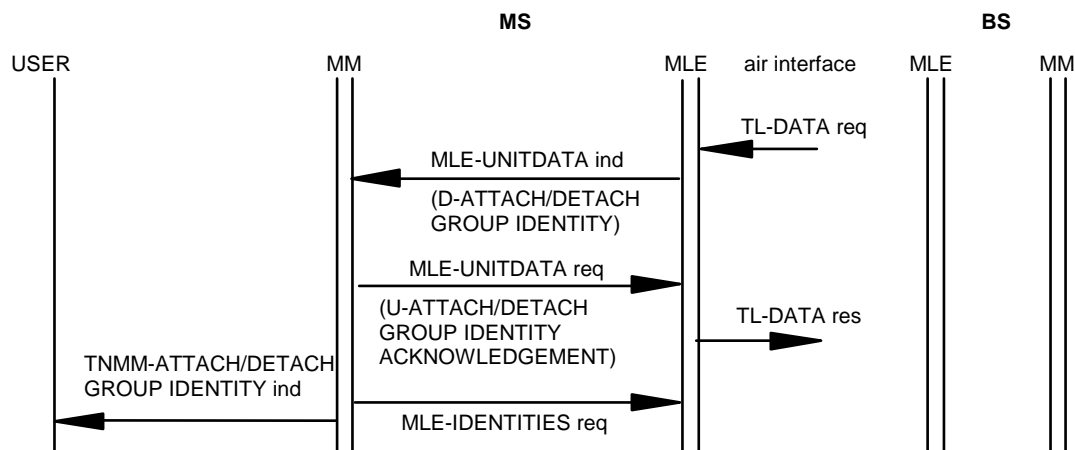


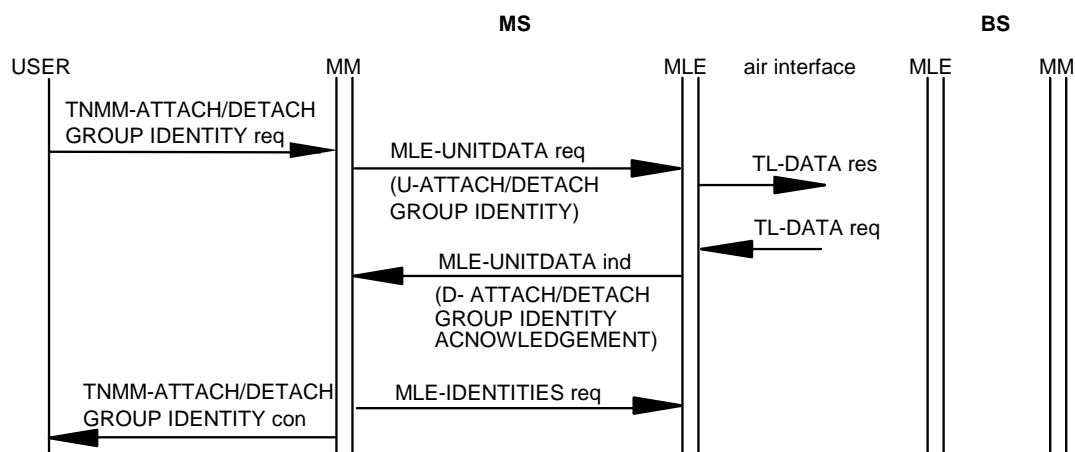
Figure 56: SwMI initiated attachment/detachment of group identities

When SwMI initiates group attachment/detachment by sending a D-ATTACH/DETACH GROUP IDENTITY PDU it shall set the group identity report to "not report request" and the group report response information element shall not be included into the PDU. If SwMI wishes to add to or remove some of the group identities attached in the MS it shall set the group identity attach/detach mode information element to "amendment". If SwMI wishes to detach all attached group identities from the MS and replace the attached group identities by new ones it shall set the group identity attach/detach mode information element to "detach all currently attached group identities and attach group identities defined in the group identity".

Upon receipt the D-ATTACH/DETACH GROUP IDENTITY PDU, MM shall inspect the attachment/detachment requests for group identities from the PDU. MM shall send valid group identities and related (V)GSSIs with an MLE-IDENTITIES request primitive to the MLE. If the group identity acknowledgement request field is set to acknowledgement requested, then the MM shall send a U-ATTACH/DETACH GROUP IDENTITY ACKNOWLEDGEMENT PDU to the MLE in an MLE-UNITDATA request. The U-ATTACH/DETACH GROUP IDENTITY ACKNOWLEDGEMENT PDU shall contain rejected attachments and may contain accepted attachments and detachments, refer to annex F. Those group identities which were in the D-ATTACH/DETACH GROUP IDENTITY PDU but are not contained in the U-ATTACH/DETACH GROUP IDENTITY ACKNOWLEDGEMENT PDU are accepted. PDU priority shall be set to 6. Finally the MM shall inform the user application about changes in attached/detached group identities by issuing a TNMM-ATTACH/DETACH GROUP IDENTITY indication. The MM shall inform the user application using only the GTSIs while the (V)GSSIs is not known by the user application.

Infrastructure initiated attachment/detachment of group identities is not applicable to a MS in the temporarily disabled state and MS shall not send U-ATTACH/DETACH GROUP IDENTITY ACKNOWLEDGEMENT PDU or modify group information.

## 16.8.2 MS initiated attachment/detachment of group identities procedure



**Figure 57: MS initiated attachment/detachment of group identities, acknowledgement requested**

Upon receipt of a TNMM-ATTACH/DETACH GROUP IDENTITY request primitive from the user application the MM shall send a U-ATTACH/DETACH GROUP IDENTITY PDU to the MLE in an MLE-UNITDATA request primitive using parameters defined in the TNMM-ATTACH/DETACH GROUP IDENTITY request primitive (see clause 17). MM shall set the group identity report to "not report request" and the group report response information element shall not be included into the PDU. If MS wishes to add to or remove some of the group identities attached in the MS it shall set the group identity attach/detach mode information element to "amendment". If MS wishes to detach all attached group identities from the MS and replace the attached group identities by new ones it shall set the group identity attach/detach mode information element to "detach all currently attached group identities and attach group identities defined in the group identity". PDU priority shall be set to 3. Timer T353 shall be started.

The MM should not try to attach those group identities which have been permanently detached by the current network. In addition the MM should not try to attach those group identities which have earlier been attached in the current network with parameter values "Attachment not allowed for next ITSI attach" if the group is not already attached.

**NOTE:** Independently of the attachment lifetime the MS is allowed to re-attach a group which is currently attached, when the user application within MS for example changes the class of usage value of the group.

Upon receipt of a D-ATTACH/DETACH GROUP IDENTITY ACKNOWLEDGEMENT PDU, timer T353 shall be stopped. The D-ATTACH/DETACH GROUP IDENTITY ACKNOWLEDGEMENT PDU shall indicate those group identities which were not accepted with a rejection reason in the group identity detachment downlink information element, refer to clause 16.10.20, and it may contain also accepted group identities. The SwMI may reject group identity detachment by adding the group attachment into the D-ATTACH/DETACH GROUP IDENTITY ACKNOWLEDGEMENT PDU.

If the MS requested attachment/detachment of group identities, the MM shall examine whether the attachments and/or detachments requested were accepted by the SwMI. The MM shall send the attached group identities and related (V)GSSIs with MLE-IDENTITIES request to the MLE.

If the group identity downlink information element does not explicitly contain the group attachment lifetime information element, then the applied lifetime is outside the scope of the present document.

Finally the MM shall inform the user application by issuing a TNMM-ATTACH/DETACH GROUP IDENTITY confirm. The MM shall inform the user application using only the GTSIs since the (V)GSSIs is not known by the user application.

MS initiated attachment/detachment of group identities is not applicable to a MS in the temporarily disabled state. In the temporary disabled state upon receipt of a TNMM-ATTACH/DETACH GROUP IDENTITY request primitive MM shall not send a U- ATTACH/DETACH GROUP IDENTITY PDU and may issue a TNMM-DISABLING indication service primitive to the user application.

### 16.8.3 SwMI initiated group report procedure

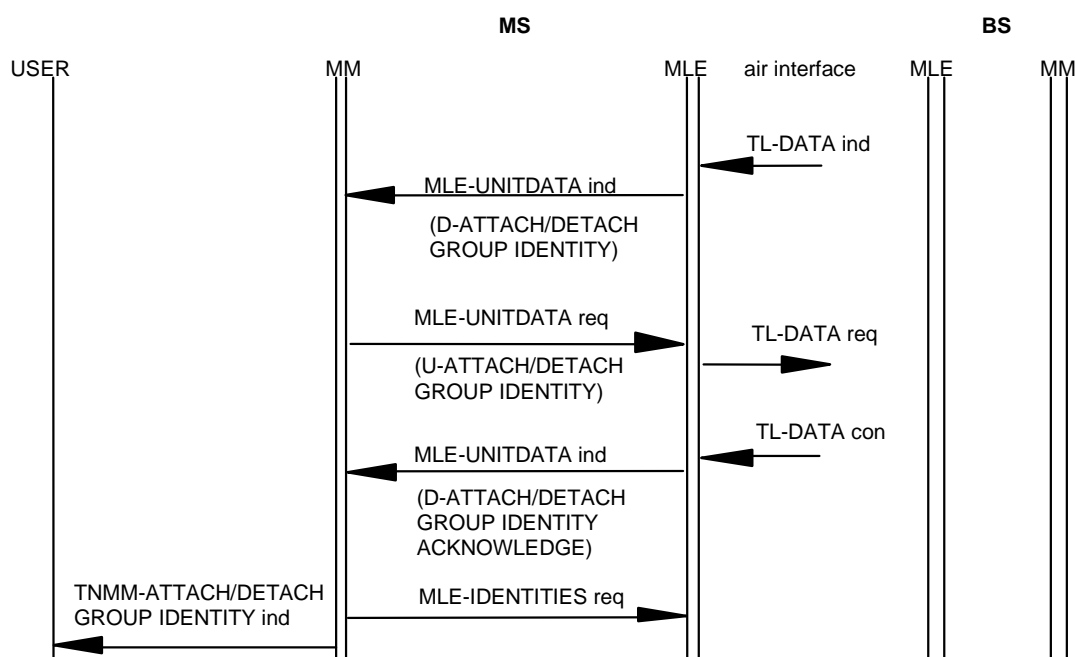


Figure 58: SwMI initiated group report

In the SwMI initiated group report procedure, the SwMI requests the MS to start group attachment and the MS shall re-attach those groups it wishes to remain valid, including group identities with lifetime parameter value "Attachment not needed". When receiving the group report request, the MM shall regard all the group identities no more attached. If the MS wishes to receive signalling on those group identities, the MM has to re-attach them. The MM should not try to attach those group identities which have been permanently detached by the current network. In addition the MM should not try to attach those group identities which have earlier been attached in the current network with parameter values "Attachment not allowed for next ITSI attach" if the group is not already attached. The attachment request may also contain group identities which were temporarily detached or indicated as unknown by the SwMI, refer to clause 16.10.20.

Upon receipt of the D-ATTACH/DETACH GROUP IDENTITY PDU from the MLE, MM shall check that the group identity report information element indicates that a "group report" is requested. The group identity acknowledgement request information element value shall be "acknowledgement not requested", MS shall ignore the value of the group identity attach/detach mode information element and group identity downlink information elements shall not be present in the PDU. As the response MM shall send a U-ATTACH/DETACH GROUP IDENTITY PDU containing the reported groups, the group identity attach/detach mode information element shall be set to "detach all currently attached group identities and attach group identities defined in the group identity" and the group identity report information element to "not report request" and if all the reported groups do fit into one U-ATTACH/DETACH GROUP IDENTITY PDU it shall contain a group report response information element indicating "group report complete". The PDU priority shall be set to 3. Timer T353 shall be started. If the reported groups do not fit in one U-ATTACH/DETACH GROUP IDENTITY PDU, the group report response information element shall not be included and subsequent groups shall be reported using U-ATTACH/DETACH GROUP IDENTITY PDUs as presented above except that the group identity attach/detach mode information element shall be set to "Amendment". The PDU priority shall be set to 3. Timer T353 shall be started. MM shall expect that each U-ATTACH/DETACH GROUP IDENTITY PDU is acknowledged individually before sending next U-ATTACH/DETACH GROUP IDENTITY PDU by the corresponding D-ATTACH/DETACH GROUP IDENTITY ACKNOWLEDGEMENT PDU.

Upon receipt of each D-ATTACH/DETACH GROUP IDENTITY ACKNOWLEDGEMENT PDU, timer T353 shall be stopped. MM shall send the accepted and thus attached group identities and related (V)GSSIs with the MLE-IDENTITIES request to the MLE.

In the last U-ATTACH/DETACH GROUP IDENTITY PDU containing the last reported group, the Group report response information element shall be present and set to "Group report complete".

If the MS has no groups to report, the Group report response information element shall be present and set to "Group report complete", the Group identity uplink information element shall not be present and the Group identity attach/detach mode shall be set to "detach all currently attached group identities and attach group identities defined in the group identity".

Infrastructure initiated group reporting is not applicable to a MS in the temporarily disabled state and MS shall not send U-ATTACH/DETACH GROUP IDENTITY PDU or modify group information.

#### 16.8.4 MS initiated group report procedure

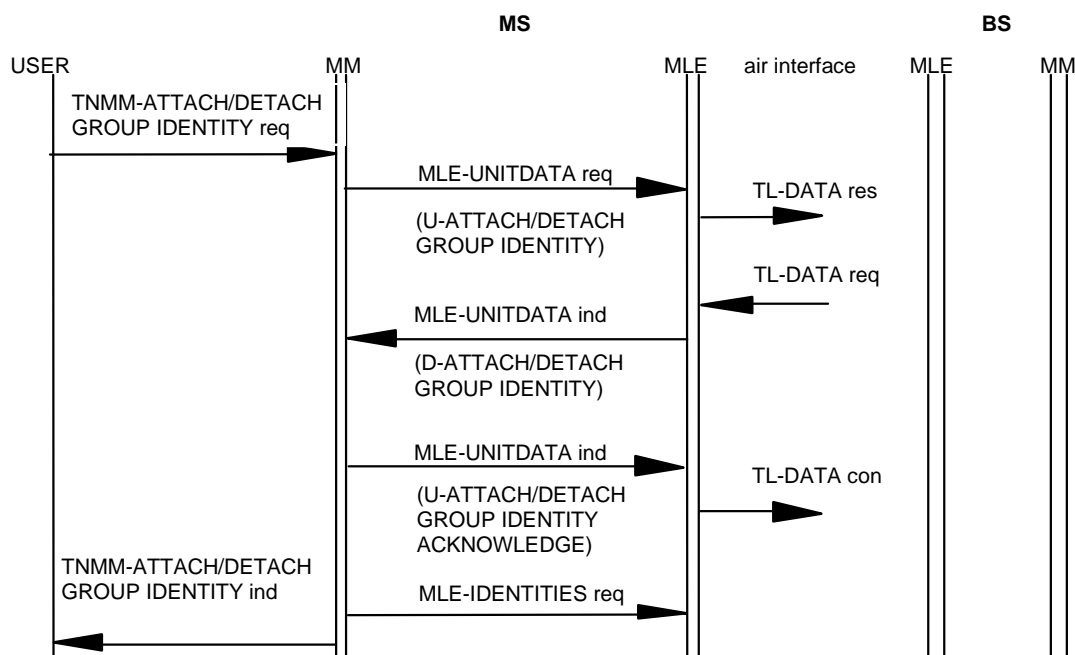


Figure 59a: MS initiated group report

In the MS initiated group report procedure MS requests SwMI to start group attachment and the SwMI shall re-attach those groups it wishes to be attached in the MS and thus be valid downlink identities.

Upon receipt of a TNMM-ATTACH/DETACH GROUP IDENTITY request primitive containing group report request from the user application the MM shall send a U-ATTACH/DETACH GROUP IDENTITY PDU containing the value "report request" in the group identity report information element. The group identity attach/detach mode information element value shall be "amendment", and group identity uplink information elements shall not be present in the PDU. The PDU priority shall be set to 3. Timer T353 shall be started.

If the SwMI accepts the group report request it shall send a D-ATTACH/DETACH GROUP IDENTITY PDU containing the group identity attach/detach mode information element set to "detach all currently attached group identities and attach group identities defined in the group identity.." and the group identity acknowledgement request information element set either to "acknowledgement requested" or "acknowledgement not requested" and if all reported groups fit into one D-ATTACH/DETACH GROUP IDENTITY PDU, the "Group report response" information element shall be included and indicate "group report complete".

If the Group identity downlink information element is not present and the Group report response information element indicates "group report complete", then the SwMI has no groups to report.

If the reported groups do not fit in one D-ATTACH/DETACH GROUP IDENTITY PDU, the Group report response information element shall not be included and subsequent groups shall be reported using D-ATTACH/DETACH GROUP IDENTITY PDUs as presented above except that the group identity attach/detach mode information element shall be set to "Amendment".

In the last D-ATTACH/DETACH GROUP IDENTITY PDU the Group report response information element shall be included and indicate "group report complete".

Upon receipt of each D-ATTACH/DETACH GROUP IDENTITY PDU, T353 shall be stopped, if running. The MS shall check that the Group identity attach/detach mode element is "detach all currently attached group identities and attach group identities defined in the group identity..". The MM shall send the attached group identities and related (V)GSSIs with MLE-IDENTITIES request to the MLE. When the Group report response element indicates that the group report is complete MS knows that it has received the whole group information. If the group identity acknowledgement request information element was set to "acknowledgement requested", MM shall individually acknowledge each D-ATTACH/DETACH GROUP IDENTITY PDU by sending the corresponding U-ATTACH/DETACH GROUP IDENTITY ACKNOWLEDGEMENT PDU. PDU priority shall be set to 6.

If the MS initiated group reporting collides with a SwMI initiated group attachment the MS can detect it when the attach/detach mode is "amendment" and the MS shall assume that the actual report will follow later and shall not send the corresponding U-ATTACH/DETACH GROUP IDENTITY ACKNOWLEDGEMENT PDU as long as the timer T353 is running.

MS initiated group reporting is not applicable to a MS in the temporarily disabled state. In the temporary disabled state upon receipt of a TNMM-ATTACH/DETACH GROUP IDENTITY request primitive MM shall not send a U-ATTACH/DETACH GROUP IDENTITY PDU and may issue a TNMM-DISABLING indication service primitive to the user application.

### 16.8.5 Expiry of timer T353

On the expiry of timer T353, if it is still possible to solely cancel the outstanding PDU according to clause 16.3.1.3, MM shall issue an MLE-CANCEL request with the handle of the transmission request it corresponds to. If it is no longer possible to solely cancel the outstanding PDU according to clause 16.3.1.3, MM shall return a failure report to the SAP and the user application should assume that the requested service has failed.

### 16.8.6 Colliding requests for group attachment/detachment and group reporting

In the event that one party (MS / SwMI) sends attachment / detachment requests by its own initiative at the same time as the other party is requesting group report, the report request shall override the other requests. Therefore MS/SwMI must respond to the report request and abandon its own attachment / detachment request.

In case MS is attempting registration or SwMI is initiating registration at the same time as the other party is sending group report request or attachment / detachment requests, the registration shall override the other requests.



## 16.8.7 Group Identity Address Type (GIAT) usage in group identity downlink/uplink

The Group Identity Address Type (GIAT) shall be used in the Group identity downlink and Group identity uplink information elements to signify the group address information present for each group.

The group address information present in the Group identity uplink information element shall be as follows:

- if MS attaches/acknowledges groups belonging to its home network, i.e. MNI of the group is the same as MNI of the home network of MS:
  - if the MS is registered to its home system, the GSSI information element shall be present (GIAT shall be set to 0);
  - if the MS is registered to a foreign system and the SwMI has not previously allocated a (V)GSSI to the group, the GSSI and address extension information elements shall be present (GIAT shall be set to 1);
  - if the MS is registered to a foreign system and the SwMI has previously allocated (V)GSSI, the (V)GSSI information element shall be present (GIAT shall be set to 2).
- if the MS is registered to a foreign network and attaches/acknowledges groups belonging to the current network, i.e. MNI of the group is the same as MNI of the foreign network MS is registered to:
  - the GSSI information element shall be present (GIAT shall be set to 0); or
  - the GSSI and address extension information elements shall be present (GIAT shall be set to 1).

The group address information present in the Group identity downlink information element shall be as follows:

- if SwMI attaches/acknowledges groups belonging to the home network of MS, i.e. MNI of the group is the same as MNI of the home network of MS:
  - if the MS is registered to its home system, the GSSI information element shall be present (GIAT shall be set to 0);
  - if the MS is registered to a foreign network, the GSSI and address extension information elements were present in the Group Identity uplink and the SwMI rejected the attachment then the GSSI and address extension information elements shall be present (GIAT shall be set to 1);
  - if the MS is registered to a foreign network and the (V)GSSI was present in the Group Identity uplink, the (V)GSSI information element (which shall be the same (V)GSSI as present in the Group Identity uplink) shall be present (GIAT shall be set to 2);
  - if the MS is registered to a foreign network and the SwMI is initiating a group attachment/detachment and a (V)GSSI has not yet been allocated to the group, the GSSI, address extension and (V)GSSI information elements shall be present (GIAT shall be set to 3);
  - if the MS is registered to a foreign network and the SwMI is initiating a group attachment/detachment, and a (V)GSSI has already been allocated to the group, then either the (V)GSSI information element shall be present (GIAT shall be set to 2) or the GSSI, address extension and (V)GSSI information elements shall be present (GIAT shall be set to 3);
  - if the MS is registered to a foreign network, the GSSI and address extension information elements were present in the Group Identity Uplink and the SwMI accepted the attachment then the GSSI, address extension and (V)GSSI information elements shall be present (GIAT shall be set to 3);
  - if the MS is registered to a foreign network and the SwMI requires to allocate a new (V)GSSI to a GTSI which has previously been allocated a (V)GSSI (i.e. the new (V)GSSI replaces the existing (V)GSSI) then the GSSI, address extension and (V)GSSI information elements shall be present (GIAT shall be set to 3);
  - if the MS is registered to a foreign network and the MS has initiated a group report for a GTSI and the SwMI has previously allocated a (V)GSSI for the GTSI, then the GSSI, address extension and (V)GSSI information elements shall be present (GIAT shall be set to 3).

- if the MS is registered to a foreign network and SwMI attaches/acknowledges groups belonging to the current network, i.e. MNI of the group is the same as MNI of the current network MS is registered to:
  - the GSSI information element shall be present (GIAT shall be set to 0); or
  - the GSSI and address extension information elements shall be present (GIAT shall be set to 1).

### 16.8.8 PDU or function not supported

In case MS/SwMI receives an individually addressed unknown MM PDU or a request for a MM function which is not supported, the receiving entity may send MM PDU/FUNCTION NOT SUPPORTED PDU. The behaviour of the requesting party when receiving MM PDU/FUNCTION NOT SUPPORTED PDU is outside the scope of the present document.

NOTE: The same PDU may be used for several functions, e.g. by sending U-LOCATION UPDATE DEMAND PDU the MS may request either group attachment/detachment or group report and D-LOCATION UPDATE COMMAND may also include a group report request in addition to the registration request.

## 16.9 MM PDU structures and contents

### 16.9.1 MM PDU general description

Refer to annex E for PDU encoding rules and examples. The usage of security related information elements is presented in EN 300 392-7 [11] and the usage of DMO gateway related information elements is presented in ETS 300 396-5 [14].

**Table 147: PDU layout (void)**

The information contained in the PDU description tables which follow corresponds to the following key:

- Length: length of the information element in bits;
- Type: information element type (1, 2, or 3) as defined below;
- C/O/M: conditional/optional/mandatory information in the PDU;
- Remark: comment.

### 16.9.2 MM PDU description tables - downlink

#### 16.9.2.1 D-ATTACH/DETACH GROUP IDENTITY

- Message: D-ATTACH/DETACH GROUP IDENTITY
- Response to: -U-ATTACH/DETACH GROUP IDENTITY (report request)
- Response expected: -/U-ATTACH/DETACH GROUP IDENTITY ACKNOWLEDGEMENT
- Short description: The infrastructure sends this message to the MS to indicate attachment/detachment of group identities for the MS or to initiate a group report request or give a group report response.

**Table 148: D-ATTACH/DETACH GROUP IDENTITY PDU contents**

Information element	Length	Type	C/O/M	Remark
PDU type	4	1	M	
Group identity report	1	1	M	
Group identity acknowledgement request	1	1	M	
Group identity attach/detach mode	1	1	M	
Proprietary		3	O	
Group report response		3	O	
Group identity downlink		4	O	

### 16.9.2.2 D-ATTACH/DETACH GROUP IDENTITY ACKNOWLEDGEMENT

- Message: D-ATTACH/DETACH GROUP IDENTITY ACKNOWLEDGEMENT
- Response to: U-ATTACH/DETACH GROUP IDENTITY
- Response expected: -
- Short description: The infrastructure sends this message to the MS to acknowledge MS initiated attachment/detachment of group identities.

**Table 149: D-ATTACH/DETACH GROUP IDENTITY ACKNOWLEDGEMENT PDU contents**

Information element	Length	Type	C/O/M	Remark
PDU type	4	1	M	
Group identity accept/reject	1	1	M	
Reserved	1	1	M	
Proprietary		3	O	
Group identity downlink		4	O	

### 16.9.2.3 D-DISABLE (Void)

**Table 150: D-DISABLE contents (Void)**

### 16.9.2.4 D-ENABLE (Void)

**Table 151: D-ENABLE contents (Void)**

### 16.9.2.5 D-MM STATUS

#### 16.9.2.5.1 D-MM STATUS generic structure

- Message: D-MM STATUS
- Response to: -/U-MM STATUS,
- Response expected: -/U-MM STATUS
- Short description: The infrastructure sends this message to the MS to request or indicate/reject a change of an operation mode.

**Table 152: D-MM STATUS PDU generic contents**

Information element	Length	Type	C/O/M	Remark
PDU type	4	1	M	
Status downlink	6	1	M	see notes 1 and 3
Status downlink dependant information	Varies			see note 2
NOTE 1: This information element shall indicate the requested service or a response to a request and the sub-type of the D-MM STATUS PDU.				
NOTE 2: This information element or set of information elements shall be as defined by the status downlink information element, refer to clauses 16.9.2.5.1 to 16.9.2.5.7.				
NOTE 3: This Status downlink element is indicating which sub-PDU this D-MM STATUS PDU contains. In case the receiving party does not support indicated function but is able to recognise this PDU structure, it should set the received value of Status downlink element to Not-supported sub PDU type element.				

### 16.9.2.5.2 D-CHANGE OF ENERGY SAVING MODE REQUEST

The status downlink information element value "Change of energy saving mode request" defines the D-CHANGE OF ENERGY SAVING MODE REQUEST PDU and the D-MM STATUS PDU shall contain information elements as defined in table 152a.

- Message: D-CHANGE OF ENERGY SAVING MODE REQUEST
- Response to: -
- Response expected: U-CHANGE OF ENERGY SAVING MODE RESPONSE
- Short description: The infrastructure sends this message to the MS to modify or stop a current energy economy mode, or allocate an energy economy mode.

**Table 152a: D-CHANGE OF ENERGY SAVING MODE REQUEST PDU contents**

Information element	Length	Type	C/O/M	Remark
PDU type	4	1	M	
Status downlink	6	1	M	
Energy saving information	14	1	M	
Proprietary	Variable	3	O	

### 16.9.2.5.3 D-CHANGE OF ENERGY SAVING MODE RESPONSE

The status downlink information element value "Change of energy saving mode response" defines the D-CHANGE OF ENERGY SAVING MODE RESPONSE PDU and the D-MM STATUS PDU shall contain information elements as defined in table 152B.

- Message: D-CHANGE OF ENERGY SAVING MODE RESPONSE
- Response to: U-CHANGE OF ENERGY SAVING MODE REQUEST
- Response expected: -
- Short description: The infrastructure sends this message to the MS to indicate the start point of an accepted energy economy mode or to reject a request for energy economy mode.

**Table 152B: D-CHANGE OF ENERGY SAVING MODE RESPONSE PDU contents**

Information element	Length	Type	C/O/M	Remark
PDU type	4	1	M	
Status downlink	6	1	M	
Energy saving information	14	1	M	
Proprietary	Variable	3	O	

#### 16.9.2.5.4 D-DUAL WATCH MODE RESPONSE

The status downlink information element value "Dual watch mode response" defines the D-DUAL WATCH MODE RESPONSE PDU and the D-MM STATUS PDU shall contain information elements as defined in table 152C.

- Message: D-DUAL WATCH MODE RESPONSE
- Response to: U-DUAL WATCH MODE REQUEST
- Response expected: -
- Short description: The infrastructure sends this message to the MS to indicate the start point of an accepted dual watch energy economy mode or to reject a request for dual watch mode.

**Table 152C: D-DUAL WATCH MODE RESPONSE PDU contents**

Information element	Length	Type	C/O/M	Remark
PDU type	4	1	M	
Status downlink	6	1	M	
Energy saving information	14	1	M	
Result of dual watch request	3	1	M	
Reserved	8	1	M	Default value = 00000000 <sub>2</sub>
SCCH information and distribution on 18th frame	6	2	O	
Proprietary		3	O	

#### 16.9.2.5.5 D-TERMINATING DUAL WATCH MODE RESPONSE

The status downlink information element value "Terminating dual watch mode response" defines the D-TERMINATING DUAL WATCH MODE RESPONSE PDU and the D-MM STATUS PDU shall contain information elements as defined in table 152D.

- Message: D-TERMINATING DUAL WATCH MODE RESPONSE
- Response to: U-TERMINATING DUAL WATCH MODE REQUEST
- Response expected: -
- Short description: The infrastructure sends this message to the MS to accept a request to terminate dual watch and may optionally indicate the start point of an accepted energy economy mode after dual watch operation.

**Table 152D: D-TERMINATING DUAL WATCH MODE RESPONSE PDU contents**

Information element	Length	Type	C/O/M	Remark
PDU type	4	1	M	
Status downlink	6	1	M	
Reserved	8	1	M	Default value = 00000000 <sub>2</sub>
Energy saving information	14	2	O	
SCCH information and distribution on 18th frame	6	2	O	
Proprietary		3	O	

### 16.9.2.5.6 D-CHANGE OF DUAL WATCH MODE REQUEST

The status downlink information element value "Change of dual watch mode request" defines the D-CHANGE OF DUAL WATCH MODE REQUEST PDU and the D-MM STATUS PDU shall contain information elements as defined in table 152E.

- Message: D-CHANGE OF DUAL WATCH MODE REQUEST
- Response to: -
- Response expected: U-CHANGE OF DUAL WATCH MODE RESPONSE
- Short description: The infrastructure sends this message to the MS to change the energy economy group associated with the MS's dual watch operation or to withdraw its previous acceptance of the MS's dual watch request.

**Table 152E: D-CHANGE OF DUAL WATCH MODE REQUEST PDU contents**

Information element	Length	Type	C/O/M	Remark
PDU type	4	1	M	
Status downlink	6	1	M	
Energy saving information	14	1	M	
Reason for dual watch change by SwMI	3	1	M	
Reserved	8	1	M	Default value = 00000000 <sub>2</sub>
SCCH information and distribution on 18th frame	6	2	O	
Proprietary		3	O	

### 16.9.2.5.7 Direct mode gateway related D-MM STATUS

The status downlink information element the values in the range 010000<sub>2</sub> to 011111<sub>2</sub> indicate a DMO gateway function and the D-MM STATUS PDU shall contain information elements as defined in ETS 300 396-5 [14] annex B.

### 16.9.2.5.8 D-MS FREQUENCY BANDS REQUEST

The status downlink information element value "MS frequency bands request" defines the D-FREQUENCY BANDS REQUEST PDU and the D-MM STATUS PDU shall contain information elements as defined in table 152F.

- Message: D-MS FREQUENCY BANDS REQUEST
- Response to: -
- Response expected: U-MS FREQUENCY BANDS INFORMATION
- Short description: The infrastructure sends this message to the MS to interrogate the frequency bands that are supported by the MS.

**Table 152F: D- MS FREQUENCY BANDS REQUEST PDU contents**

Information element	Length	Type	C/O/M	Remark
PDU type	4	1	M	
Status downlink	6	1	M	
Proprietary	Variable	3	O	

## 16.9.2.5.9 DISTANCE REPORTING REQUEST

The status downlink information element value "Distance reporting request" defines the D-DISTANCE REPORTING REQUEST PDU and the D-MM STATUS PDU shall contain information elements as defined in table 152G.

- Message: D-DISTANCE REPORTING REQUEST
- Response to: -
- Response expected: -
- Short description: The infrastructure sends this message request that the MS shall send a Null PDU, if the timer has elapsed. The Null PDU will be used to measure the path delay for that MS.

Table 152G: D-DISTANCE REPORTING REQUEST PDU contents

Information element	Length	Type	C/O/M	Remark
PDU type	4	1	M	
Status downlink	6	1	M	
Distance reporting timer	7	1	M	
Distance reporting validity	1	1	M	
Proprietary		3	O	

## 16.9.2.6 D-STATUS (Void)

Table 153: D-STATUS PDU contents (Void)

## 16.9.2.7 D-LOCATION UPDATE ACCEPT

- Message: D-LOCATION UPDATE ACCEPT
- Response to: U-LOCATION UPDATE DEMAND
- Response expected: -
- Short description: The infrastructure sends this message to the MS to indicate that updating in the network has been completed.

Table 154: D-LOCATION UPDATE ACCEPT contents

Information element	Length	Type	C/O/M	Remark
PDU type	4	1	M	
Location update accept type	3	1	M	
SSI	24	2	O	ASSI/(V)ASSI of MS
Address extension	24	2	O	MNI of MS
Subscriber class	16	2	O	
Energy saving information	14	2	O	
SCCH information and distribution on 18 <sup>th</sup> frame	6	2	O	
New registered area		4	O	
Group identity location accept		3	O	
Default group attachment lifetime		3	O	
Authentication downlink		3	O	See EN 300 392-7 [11].
Proprietary		3	O	

### 16.9.2.8 D-LOCATION UPDATE COMMAND

- Message: D-LOCATION UPDATE COMMAND
- Response to: -
- Response expected: U-LOCATION UPDATE DEMAND
- Short description: The infrastructure sends this message to the MS to initiate a location update demand in the MS.

**Table 155: D-LOCATION UPDATE COMMAND contents**

Information element	Length	Type	C/O/M	Remark
PDU type	4	1	M	
Group identity report	1	1	M	
Cipher control	1	1	M	
Ciphering parameters	10		C	see note
Address extension	24	2	O	MNI of the MS
Proprietary		3	O	
NOTE: Information element "Ciphering parameters" is not present if "Cipher control" is set to "0", "ciphering off". Information element "ciphering parameters" is present if "Cipher control" is set to "1", "ciphering on".				

### 16.9.2.9 D-LOCATION UPDATE REJECT

- Message: D-LOCATION UPDATE REJECT
- Response to: U-LOCATION UPDATE DEMAND
- Response expected: -
- Short description: The infrastructure sends this message to the MS to indicate that updating in the network is not accepted.

**Table 156: D-LOCATION UPDATE REJECT contents**

Information element	Length	Type	C/O/M	Remark
PDU type	4	1	M	
Location update type	3	1	M	
Reject cause	5	1	M	
Cipher control	1	1	M	
Ciphering parameters	10		C	see note
Address extension	24	2	O	MNI of the MS
Proprietary		3	O	
NOTE: Information element "Ciphering parameters" is not present if "Cipher control" is set to "0", "ciphering off". Information element "Ciphering parameters" is present if "Cipher control" is set to "1", "ciphering on".				

### 16.9.2.10 D-LOCATION UPDATE PROCEEDING

- Message: D-LOCATION UPDATE PROCEEDING
- Response to: U-LOCATION UPDATE DEMAND
- Response expected: -
- Short description: The infrastructure sends this message to the MS on registration at accepted migration to assign a (V) ASSI.



**Table 157: D-LOCATION UPDATE PROCEEDING contents**

Information element	Length	Type	C/O/M	Remark
PDU type	4	1	M	
SSI	24	1	M	(V)ASSI of the MS
Address extension	24	1	M	MNI of the MS
Proprietary		3	O	

### 16.9.3 MM PDU descriptions - uplink

#### 16.9.3.1 U-ATTACH/DETACH GROUP IDENTITY

- Message: U-ATTACH/DETACH GROUP IDENTITY
- Response to: -/D-ATTACH/DETACH GROUP IDENTITY (report request)
- Response expected: D-ATTACH/DETACH GROUP IDENTITY ACKNOWLEDGEMENT
- Short description: The MS sends this message to the infrastructure to indicate attachment/detachment of group identities in the MS or to initiate a group report request or give a group report response.

**Table 158: U-ATTACH/DETACH GROUP IDENTITY contents**

Information element	Length	Type	C/O/M	Remark
PDU type	4	1	M	
Group identity report	1	1	M	
Group identity attach/detach mode	1	1	M	
Group report response		3	O	
Group identity uplink		4	O	
Proprietary		3	O	

#### 16.9.3.2 U-ATTACH/DETACH GROUP IDENTITY ACKNOWLEDGEMENT

- Message: U-ATTACH/DETACH GROUP IDENTITY ACKNOWLEDGEMENT
- Response to: D-ATTACH/DETACH GROUP IDENTITY
- Response expected: -
- Short description: The MS sends this message to the infrastructure to acknowledge SwMI initiated attachment/detachment of group identities.

**Table 159: U-ATTACH/DETACH GROUP IDENTITY ACKNOWLEDGEMENT contents**

Information element	Length	Type	C/O/M	Remark
PDU type	4	1	M	
Group identity acknowledgement type	1	1	M	
Group identity uplink		4	O	
Proprietary		3	O	

### 16.9.3.3 U-ITSI DETACH

- Message: U-ITSI DETACH
- Response to: -
- Response expected: -/D-MM STATUS
- Short description: The MS sends this message to the infrastructure to announce that the MS will be de-activated.

**Table 160: U-ITSI DETACH contents**

Information element	Length	Type	C/O/M	Remark
PDU type	4	1	M	
Address extension	24	2	O	MNI of the MS
Proprietary		3	O	

### 16.9.3.4 U-LOCATION UPDATE DEMAND

- Message: U-LOCATION UPDATE DEMAND
- Response to: -/D-LOCATION UPDATE COMMAND
- Response expected: D-LOCATION UPDATE ACCEPT/D-LOCATION UPDATE REJECT
- Short description: The MS sends this message to the infrastructure to request update of its location registration.

**Table 161: U-LOCATION UPDATE DEMAND contents**

Information element	Length	Type	C/O/M	Remark
PDU type	4	1	M	
Location update type	3	1	M	
Request to append LA	1	1	M	
Cipher control	1	1	M	
Ciphering parameters	10		C	see note
Class of MS	24	2	O	
Energy saving mode	3	2	O	
LA information		2	O	
SSI	24	2	O	ISSI of the MS
Address extension	24	2	O	MNI of the MS
Group identity location demand		3	O	
Group report response		3	O	
Authentication uplink		3	O	See EN 300 392-7 [11].
Proprietary		3	O	
NOTE: Information element "Ciphering parameters" is not present if "Cipher control" is set to "0", "ciphering off". Information element "ciphering parameters" is present if "Cipher control" is set to "1", "ciphering on".				

### 16.9.3.5 U-MM STATUS

#### 16.9.3.5.1 U-MM STATUS generic construction

- Message: U-MM STATUS
- Response to: -/D-MM STATUS
- Response expected: -/D-MM STATUS
- Short description: The MS sends this message to the infrastructure to request or respond to a mode change.

**Table 162: U-MM STATUS PDU generic contents**

Information element	Length	Type	C/O/M	Remark
PDU type	4	1	M	
Status uplink	6	1	M	see notes 1 and 3
Status uplink dependent information	Variable			see note 2
NOTE 1: This information element shall indicate the requested service or a response to a request and the sub-type of the U-MM STATUS PDU.				
NOTE 2: This information element or set of information elements shall be as defined by the status uplink information element, refer to clauses 16.9.3.5.1 to 16.9.3.5.8.				
NOTE 3: This Status uplink element is indicating which sub-PDU this U-MM STATUS PDU contains. In case the receiving party does not support indicated function but is able to recognise this PDU structure, it should set the received value of Status uplink element to Not-supported sub PDU type element.				

#### 16.9.3.5.2 U-CHANGE OF ENERGY SAVING MODE REQUEST

The status uplink information element value "Change of energy saving mode request" indicates the U-CHANGE OF ENERGY SAVING MODE REQUEST PDU and the U-MM STATUS PDU shall contain information elements as defined in table 162a.

- Message: U-CHANGE OF ENERGY SAVING MODE REQUEST
- Response to: -
- Response expected: D-CHANGE OF ENERGY SAVING MODE RESPONSE
- Short description: The MS sends this message to the infrastructure to change its energy economy mode i.e. to start or end energy economy operation or to change the energy economy group.

**Table 162a: U-CHANGE OF ENERGY SAVING MODE REQUEST PDU contents**

Information element	Length	Type	C/O/M	Remark
PDU type	4	1	M	
Status uplink	6	1	M	
Energy saving mode	3	1	M	
Proprietary	Variable	3	O	

### 16.9.3.5.3 U-CHANGE OF ENERGY SAVING MODE RESPONSE

The status uplink information element value "Change of energy saving mode response" indicates the U-CHANGE OF ENERGY SAVING MODE RESPONSE PDU and the U-MM STATUS PDU shall contain information elements as defined in table 162B.

- Message: U-CHANGE OF ENERGY SAVING MODE RESPONSE
- Response to: D-CHANGE OF ENERGY SAVING MODE REQUEST
- Response expected: -
- Short description: The MS sends this message to the infrastructure to accept or reject a change of its energy economy mode.

**Table 162B: U-CHANGE OF ENERGY SAVING MODE RESPONSE PDU contents**

Information element	Length	Type	C/O/M	Remark
PDU type	4	1	M	
Status uplink	6	1	M	
Energy saving mode	3	1	M	
Proprietary	Variable	3	O	

### 16.9.3.5.4 U-DUAL WATCH MODE REQUEST

The status uplink information element value "Dual watch mode request" indicates the U-DUAL WATCH MODE REQUEST PDU and the U-MM STATUS PDU shall contain information elements as defined in table 162C.

- Message: U-DUAL WATCH MODE REQUEST
- Response to: -
- Response expected: D-DUAL WATCH MODE RESPONSE
- Short description: The MS sends this message to the infrastructure to request start of dual watch operation with an appropriate energy economy group or to change the energy economy group associated with its dual watch operation or to re-request dual watch operation after a re-registration.

**Table 162C: U-DUAL WATCH MODE REQUEST PDU contents**

Information element	Length	Type	C/O/M	Remark
PDU type	4	1	M	
Status uplink	6	1	M	
Energy saving mode	3	1	M	
MS operating with type 2 repeater	1	1	M	
Dual watch mode	1	1	M	
DMO carrier	13/25	2	O	
Start of Direct Mode Operation cause	3	2	O	
Mode change information	6	2	O	
Proprietary		3	O	

### 16.9.3.5.5 U-TERMINATING DUAL WATCH MODE REQUEST

The status uplink information element value "Terminating dual watch mode request" indicates the U-TERMINATING DUAL WATCH MODE REQUEST PDU and the U-MM STATUS PDU shall contain information elements as defined in table 162D.

- Message: U-TERMINATING DUAL WATCH MODE REQUEST
- Response to: -
- Response expected: D-TERMINATING DUAL WATCH MODE RESPONSE
- Short description: The MS sends this message to the infrastructure to indicate an end of dual watch mode and, optionally, requesting energy economy operation.

**Table 162D: U-TERMINATING DUAL WATCH MODE REQUEST PDU contents**

Information element	Length	Type	C/O/M	Remark
PDU type	4	1	M	
Status uplink	6	1	M	
Reserved	8	1	M	Default value = 00000000 <sub>2</sub>
Energy saving mode	3	2	O	
Proprietary		3	O	

### 16.9.3.5.6 U-CHANGE OF DUAL WATCH MODE RESPONSE

The status uplink information element value "Change of dual watch mode response" indicates the U-CHANGE OF DUAL WATCH MODE RESPONSE PDU and the U-MM STATUS PDU shall contain information elements as defined in table 162E.

- Message: U-CHANGE OF DUAL WATCH MODE RESPONSE
- Response to: D-CHANGE OF DUAL WATCH MODE REQUEST
- Response expected: -
- Short description: The MS sends this message to the infrastructure to accept a change to its dual watch operation (or to reject the change if it is not currently operating in dual watch).

**Table 162E: U-CHANGE OF DUAL WATCH MODE RESPONSE PDU contents**

Information element	Length	Type	C/O/M	Remark
PDU type	4	1	M	
Status uplink	6	1	M	
Energy saving mode	3	1	M	
Reserved	8	1	M	Default value = 00000000 <sub>2</sub>
Proprietary		3	O	

### 16.9.3.5.7 U-START OF DIRECT MODE OPERATION

The status uplink information element value "Start of direct mode operation" indicates the U-START OF DIRECT MODE OPERATION PDU and the U-MM STATUS PDU shall contain information elements as defined in table 162Fa.

- Message: U-START OF DIRECT MODE OPERATION
- Response to: -
- Response expected: -
- Short description: The MS sends this message to the infrastructure to indicate a start of direct mode operation without dual watch.

**Table 162Fa: U-START OF DIRECT MODE OPERATION PDU contents**

Information element	Length	Type	C/O/M	Remark
PDU type	4	1	M	
Status uplink	6	1	M	
Reserved	5	1	M	Default value = 00000 <sub>2</sub>
DMO carrier	13/25	2	O	
Start of direct mode operation cause	3	2	O	
Mode change information	6	2	O	
Proprietary		3	O	

### 16.9.3.5.8 Direct mode gateway related U-MM STATUS

For the status uplink information element the values in the range 010000<sub>2</sub> to 011111<sub>2</sub> indicate a DMO gateway function and the U-MM STATUS PDU shall contain information elements as defined in ETS 300 396-5 [14] annex B.

### 16.9.3.5.9 U-MS FREQUENCY BANDS INFORMATION

The status uplink information element value "MS frequency bands information" defines the U-MS FREQUENCY BANDS INFORMATION PDU and the U-MM STATUS PDU shall contain information elements as defined in table 162Fb.

- Message: U-MS FREQUENCY BANDS INFORMATION
- Response to: -/ D-MS FREQUENCY BANDS REQUEST
- Response expected: -
- Short description: The MS sends this message to the infrastructure to indicate which frequency bands it supports.

**Table 162Fb: U-MS FREQUENCY BANDS PDU contents**

Information element	Length	Type	C/O/M	Remark
PDU type	4	1	M	
Status uplink	6	1	M	
Number of frequency band definitions	3	1	M	
Frequency band definition	37		C	see note
Proprietary		3	O	
NOTE: This information element shall be present as many times as defined by the number of frequency band definitions information element. If the element has value 0, the Frequency band definition element is not present.				

## 16.9.4 PDU description tables - downlink and uplink

### 16.9.4.1 MM FUNCTION NOT SUPPORTED

- Message: MM FUNCTION NOT SUPPORTED
- Response to: Any individually addressed MM PDU
- Response expected: -
- Short description: This PDU may be sent by the MS/LS or SwMI to indicate that the received MM PDU or the function indicated in the PDU is not supported.

**Table 162G: MM FUNCTION NOT SUPPORTED PDU contents**

Information element	Length	Type	Owner	C/O/M	Remark
PDU type	4	1	MM	M	
Not-supported PDU type	4	1	MM	M	see note 1
Not-supported sub PDU type	varies	2	MM	O	see note 2
Length of the copied PDU	8	2	MM	O	
Received PDU contents	Variable		MM	C	see notes 3 and 4
NOTE 1: This information element shall identify the received PDU which contains the function which cannot be supported.					
NOTE 2: In case the receiving party recognises the PDU and the PDU contains a sub-PDU field (like in U/M-MM STATUS PDU, U/D-OTAR, U/D-ENABLE etc.) this element contains the element indicating which sub-PDU this is.					
NOTE 3: The length of this element is indicated by the Length of the copied PDU element. This element is not present if the Length of the copied PDU element is not present.					
NOTE 4: This element contains the received PDU beginning from and excluding the PDU type element.					

## 16.10 MM information elements coding

### 16.10.1 Address extension

The address extension information element shall indicate the extended part of TSI address as defined in table 163.

**Table 163: Address extension information element contents**

Information sub-element	Length	Type	C/O/M	Remark
Mobile Country Code (MCC)	10	1	M	
Mobile Network Code (MNC)	14	1	M	

### 16.10.2 Cipher control

The cipher control information element shall indicate whether ciphering is on or off as defined in table 164.

**Table 164: Cipher control information element contents**

Information element	Length	Value	Remark
Cipher Control	1	0	Ciphering off
		1	Refer to EN 300 392-7 [11]

### 16.10.3 Cipher parameters

For the cipher parameters information element refer to EN 300 392-7 [11].

**Table 165: (void)**

### 16.10.4 Cipher key type (Void)

**Table 166: (void)**

### 16.10.5 Class of MS

The class of MS information element shall indicate to the infrastructure the characteristics of the MS terminal, both hardware and software. The total information element length is 24 bits and the values can be given both as a bit map and as values. The decoding shall be as defined in table 167.

**Table 167: Class of MS information element contents**

Information sub-element	Length	Value	Remark
Frequency simplex/duplex	1	0	Frequency simplex supported
		1	Frequency duplex and simplex supported
Single/multislot	1	0	Single slot supported
		1	Multislot and single slot supported
Concurrent multicarrier operation	1	0	Single carrier operation supported
		1	Multi and single carrier operation supported
Voice	1	0	No voice calls supported
		1	Voice calls supported
End-to-end encryption	1	0	End-to-end encryption supported
		1	End-to-end encryption not supported
Circuit mode data	1	0	No circuit mode data supported
		1	Circuit mode data supported
TETRA packet data	1	0	TETRA packet data not supported
		1	TETRA packet data supported
Fast switching	1	0	Fast switching not supported
		1	Fast switching supported
DCK air interface encryption	1	0	DCK air interface encryption not supported
		1	DCK air interface encryption supported
CLCH needed on carrier change	1	0	No CLCH needed on carrier change
		1	CLCH needed on carrier change
Concurrent circuit mode services (see Note)	1	0	Concurrent circuit mode services not supported
		1	Concurrent circuit mode services supported
Advanced link	1	0	Advanced link not supported
		1	Advanced link supported
Minimum mode	1	0	Minimum mode not supported
		1	Minimum mode supported
Carrier specific signalling channel	1	0	Carrier specific signalling channel not supported
		1	Carrier specific signalling channel supported
Authentication	1	0	Authentication not supported
		1	Authentication supported
SCK air interface encryption	1	0	SCK air interface encryption not supported
		1	SCK air interface encryption supported



Information sub-element	Length	Value	Remark
TETRA air interface standard version number	3	000 <sub>2</sub>	ETS 300 392-2 edition 1, no security functions
		001 <sub>2</sub>	ETS 300 392-2 edition 1 and EN 300 392-7 [11] V2.1.1 or later
		010 <sub>2</sub>	EN 300 392-2 V2.3.2 and EN 300 392-7 [11] V2.1.1
		011 <sub>2</sub>	Reserved
		...etc.	...etc.
		111 <sub>2</sub>	Reserved
Common SCCH	1	0	Common SCCH not supported
		1	Common SCCH supported
Reserved	1	0	Default value
		1	Reserved for future expansion
Reserved	1	0	Default value
		1	Reserved for future expansion
Reserved	1	0	Default value
		1	Reserved for future expansion
Reserved	1	0	Default value
		1	Reserved for future expansion

NOTE: If concurrent circuit mode services are supported it is implicit that concurrent channels are supported. If concurrent circuit mode services are not supported concurrent channels are implicitly supported if the Packet Data MS type is of type "A" see clause 28.3.3.4.1

### 16.10.6 Class of usage

The class of usage information element shall define priority of the group identity as defined in table 168. The class of usage has meaning only for the user application.

**Table 168: Class of Usage information element contents**

Information element	Length	Value	Remark
Class of usage	3	000 <sub>2</sub>	Class of usage 1
		001 <sub>2</sub>	Class of usage 2
		010 <sub>2</sub>	Class of usage 3
		011 <sub>2</sub>	Class of usage 4
		100 <sub>2</sub>	Class of usage 5
		101 <sub>2</sub>	Class of usage 6
		110 <sub>2</sub>	Class of usage 7
		111 <sub>2</sub>	Class of usage 8

## 16.10.7 Disabling type

For the disabling type information element refer to EN 300 392-7 [11].

**Table 169: Disabling type information element contents (void)**

### 16.10.7a Default group attachment lifetime

The default group attachment lifetime information element shall indicate the default lifetime of the attachment of all group identities attached by the infrastructure for a MS as defined in table 169a.

**Table 169a: Default group attachment lifetime information element contents**

Information element	Length	Value	Remark
Default group attachment lifetime	2	00 <sub>2</sub>	Attachment not needed
		01 <sub>2</sub>	Attachment for next ITSI attach required
		10 <sub>2</sub>	Attachment not allowed for next ITSI attach
		11 <sub>2</sub>	Attachment for next location update required

### 16.10.7b Distance reporting timer

The distance reporting timer information element shall indicate the maximum timer between MS transmissions as defined in table 169B.

**Table 169B: Distance reporting timer information element contents**

Information element	Length	Value	Remark
Distance reporting timer	7	0	No reporting / stop reporting
		1	15 s
		2	30 s
		...etc.	...etc.
		127	31 min 45 s

### 16.10.7c Distance reporting validity

The distance reporting validity information element shall indicate the reporting validity as defined in table 169C.

**Table 169C: Distance reporting validity information element contents**

Information element	Length	Value	Remark
Distance reporting validity	1	0	Report until next location update
		1	Report until next ITSI attach or migration

## 16.10.8 Distribution on 18th frame

The distribution on 18th frame information element shall indicate on which of the 4 time slots the MS shall monitor down link information in the case of minimum mode as defined in table 170.

**Table 170: Distribution on 18th frame information element contents**

Information element	Length	Value	Remark
Distribution on 18th frame	2	00 <sub>2</sub>	Time slot 1
		01 <sub>2</sub>	Time slot 2
		10 <sub>2</sub>	Time slot 3
		11 <sub>2</sub>	Time slot 4

## 16.10.8a DMO carrier

The DMO carrier information element shall indicate the DMO radio channel as defined in table 170A.

**Table 170A: DMO carrier**

Information sub-element	Length	Type	C/O/M	Value	Remark
Carrier number	12	1	M		Carrier frequency number (see note 1)
Extended carrier numbering flag	1	1	M	0	No extended carrier numbering
				1	Extended carrier numbering
Frequency band	4		C		Provision for different frequency bands (see notes 1 and 2)
Offset	2		C		Provision for different offsets, (see notes 2 and 3)
Duplex spacing	3		C		Provision for different duplex spacing (see notes 1, 2 and 4)
DMO normal/reverse operation	1		C	0	DMO uplink frequency = DMO downlink frequency + duplex spacing (see notes 2 and 4)
				1	DMO uplink frequency = DMO downlink frequency - duplex spacing (see notes 2 and 4)
Reserved	2		C	00 <sub>2</sub>	Default value = 00 <sub>2</sub> (see note 2)
<p>NOTE 1: Refer to annex F for meaning of the values.</p> <p>NOTE 2: These information elements shall be present only when the extended carrier numbering flag has value "extended carrier numbering".</p> <p>NOTE 3: Refer to clause 21.4.4.1, table 333 for the meaning of the offset values.</p> <p>NOTE 4: When an MS requesting dual watch mode or indicating start of Direct Mode operation transmits the DMO carrier information element, it shall set the carrier number to indicate the Direct Mode RF carrier where it intends to receive. If using extended carrier numbering, the MS shall set the duplex spacing information element to indicate 0,0 MHz duplex value unless the MS expects to use a two-frequency Direct Mode repeater during its dual watch operation in which case it may set the duplex spacing information element with the DMO normal/reverse operation information element to indicate the uplink Direct Mode RF carrier. When a Direct Mode gateway transmits the DMO carrier information element (see ETS 300 396-5 [14]), it shall indicate the Direct Mode RF carrier where it intends to transmit. In the case of a two-frequency combined repeater/gateway, the repeater/gateway shall set the duplex spacing information element with the DMO normal/reverse operation information element to indicate the uplink Direct Mode RF carrier.</p>					

## 16.10.8b Dual watch mode

The dual watch mode information element shall indicate whether the MS is requesting to use full dual watch or idle dual watch as defined in table 170B.

**Table 170B: Dual watch mode information element contents**

Information element	Length	Value	Remark
Dual watch mode	1	0	Full dual watch
		1	Idle dual watch

## 16.10.9 Energy saving mode

The energy saving mode information element shall indicate which energy saving or dual watch scheme is requested (if any) as defined in table 171, refer to clause 23.7.6 for the meaning of the values.

**Table 171: Energy saving mode information element contents**

Information element	Length	Value	Remark
Energy saving mode	3	000 <sub>2</sub>	Stay Alive
		001 <sub>2</sub>	Economy mode 1 (EG1)
		010 <sub>2</sub>	Economy mode 2 (EG2)
		011 <sub>2</sub>	Economy mode 3 (EG3)
		100 <sub>2</sub>	Economy mode 4 (EG4)
		101 <sub>2</sub>	Economy mode 5 (EG5)
		110 <sub>2</sub>	Economy mode 6 (EG6)
		111 <sub>2</sub>	Economy mode 7 (EG7)

## 16.10.10 Energy saving information

The energy saving information element shall indicate which energy saving or dual watch scheme is allocated (if any) and starting point of the energy economy mode as defined in table 172.

**Table 172: Energy saving information element contents**

Information sub-element	Length	Type	C/O/M	Remark
Energy saving mode	3	1	M	
Frame Number	5	1	M	see note 1
Multiframe Number	6	1	M	see note 2
NOTE 1: When the Energy saving mode information element value is "Stay alive" this information element has no meaning and it shall be set to "00000 <sub>2</sub> ".				
NOTE 2: When the Energy saving mode information element value is "Stay alive" this information element has no meaning and it shall be set to "000000 <sub>2</sub> ".				

## 16.10.11 Frame Number

The frame number (FN) information element shall indicate TDMA frame number as defined in table 173.

**Table 173: Frame number information element contents**

Information element	Length	Value	Remark
Frame Number	5	00000 <sub>2</sub>	Reserved
		00001 <sub>2</sub>	FN1
		00010 <sub>2</sub>	FN2
		...etc.	...etc.
		10010 <sub>2</sub>	FN18
		10011 <sub>2</sub>	Reserved
		...etc.	...etc.
		11111 <sub>2</sub>	Reserved

## 16.10.11a Frequency band definition

The frequency band definition information element shall indicate the frequency capabilities of the MS as defined in table 173a.

**Table 173a: Frequency band definition information element contents**

Information element	Length	Type	C/O/M	Value	Remark
Lower edge carrier	12	1	M		see notes 1 and 2
Lower edge frequency band	4	1	M		see note 1
Upper edge carrier	12	1	M		see notes 1 and 2
Upper edge frequency band	4	1	M		see note 1
Duplex spacing	3	1	M		see note 1
Reverse operation types	2	1	M	00 <sub>2</sub>	Reserved
				01 <sub>2</sub>	Reverse operation only
				10 <sub>2</sub>	Normal operation only
				11 <sub>2</sub>	Both normal and reverse operation

NOTE 1: Refer to TS 100 392-15 [49].  
NOTE 2: The frequency band shall be defined as the BS transmitter frequency range.

## 16.10.12 Group identity accept/reject

The group identity accept/reject information element shall indicate the infrastructure response type to the MS initiated attachment/detachment of group identities as defined in table 174.

**Table 174: Group identity accept/reject information element contents**

Information element	Length	Value	Remark
Group identity accept/reject	1	0	All attachment/detachments accepted
		1	At least one attachment/detachment rejected

## 16.10.13 Group identity acknowledgement request

The group identity acknowledgement request information element shall indicate the MS response to the infrastructure initiated attachment/detachment of group identities as defined in table 175.

**Table 175: Group identity acknowledgement request information element contents**

Information element	Length	Value	Remark
Group identity acknowledgement request	1	0	Acknowledgement not requested
		1	Acknowledgement requested

## 16.10.14 Group identity acknowledgement type

The group identity acknowledgement type information element shall indicate the MS response type to the infrastructure initiated attachment/detachment of group identities as defined in table 176.

**Table 176: Group identity acknowledgement type information element contents**

Information element	Length	Value	Remark
Group identity acknowledgement type	1	0	All attachment/detachments accepted
		1	At least one attachment rejected

### 16.10.15 Group identity address type

The group identity address type information element shall indicate type of group identity address type in the attachment/detachment of group identities as defined in table 177.

**Table 177: Group identity address type information element contents**

Information element	Length	Value	Remark
Group identity address type	2	00 <sub>2</sub>	GSSI
		01 <sub>2</sub>	GTSI
		10 <sub>2</sub>	(V)GSSI
		11 <sub>2</sub>	GTSI+(V)GSSI

### 16.10.16 Group identity attachment lifetime

The group identity attachment lifetime information element shall indicate a lifetime of the attachment of the group identity defined by the infrastructure for a MS as defined in table 178.

**Table 178: Group identity attachment lifetime information element contents**

Information element	Length	Value	Remark
Group identity attachment lifetime	2	00 <sub>2</sub>	Attachment not needed
		01 <sub>2</sub>	Attachment for next ITSI attach required
		10 <sub>2</sub>	Attachment not allowed for next ITSI attach
		11 <sub>2</sub>	Attachment for next location update required

### 16.10.17 Group identity attach/detach mode

The group identity attach/detach mode information element shall indicate a mode of the attachment/detachment of group identities as defined in table 179.

**Table 179: Group identity attach/detach mode information element contents**

Information element	Length	Value	Remark
Group identity attach/detach mode	1	0	Amendment
		1	Detach all currently attached group identities and attach group identities defined in the group identity (downlink/uplink) element (if any)

### 16.10.18 Group identity attach/detach type identifier

The group identity attach/detach type identifier information element shall indicate the whether a group identity is attached or detached as defined in table 180.

**Table 180: Group identity attach/detach type identifier information element contents**

Information element	Length	Value	Remark
Group identity attach/detach type identifier	1	0	Attachment
		1	Detachment

### 16.10.19 Group identity attachment

The group identity attachment information element shall be a collection of sub elements and defined in table 181.

**Table 181: Group identity attachment information element contents**

Information sub-element	Length	Type	C/O/M	Remark
Group identity attachment lifetime	2	1	M	
Class of Usage	3	1	M	

### 16.10.20 Group identity detachment downlink

The group identity detachment downlink information element shall indicate the infrastructure detachment reasons as defined in table 182.

**Table 182: Group identity detachment downlink information element contents**

Information element	Length	Value	Remark
Group identity detachment downlink	2	00 <sub>2</sub>	Unknown group identity
		01 <sub>2</sub>	Temporary 1 detachment (see note)
		10 <sub>2</sub>	Temporary 2 detachment (see note)
		11 <sub>2</sub>	Permanent detachment
NOTE: These values are network dependent.			

### 16.10.21 Group identity detachment uplink

The group identity detachment uplink information element shall indicate the MS detachment reasons as defined in table 183.

**Table 183: Group identity detachment uplink information element contents**

Information element	Length	Value	Remark
Group identity detachment uplink	2	00 <sub>2</sub>	Unknown group identity
		01 <sub>2</sub>	No valid encryption key (end-to-end)
		10 <sub>2</sub>	User initiated
		11 <sub>2</sub>	Capacity exceeded

### 16.10.22 Group identity downlink

The group identity downlink information element shall be a collection of sub elements and defined in table 184.

**Table 184: Group identity downlink information element contents**

Information sub-element	Length	Type	C/O/M	Remark
Group identity attach/detach type identifier	1	1	M	
Group identity attachment	5		C	see note 1
Group identity detachment downlink	2		C	see note 1
Group identity address type	2	1	M	
GSSI	24		C	see note 2
Address EXTENSION	24		C	see note 2
(V) GSSI	24		C	see note 2
NOTE 1: Shall be conditional on the value of Group Identity Attach/Detach Type Identifier (GIADTI):				
- GIADTI = 0; Group Identity Attachment;				
- GIADTI = 1; Group Identity Detachment Downlink.				
NOTE 2: Shall be conditional on the value of Group Identity Address Type (GIAT):				
- GIAT = 0; GSSI;				
- GIAT = 1; GSSI + Address Extension (GTSI);				
- GIAT = 2; Visitor Group Short Subscriber Identity ((V)GSSI);				
- GIAT = 3; GSSI + Extension + Visitor Group Short Subscriber Identity (GTSI-V(GSSI)).				

### 16.10.23 Group identity location accept

The group identity location accept information element shall be a collection of sub elements and defined in table 185.

**Table 185: Group identity location accept information element contents**

Information sub-element	Length	Type	C/O/M	Remark
Group identity accept/reject	1	1	M	see note
Reserved	1	1	M	
Group identity downlink		4	O	
NOTE: Accept/reject has meaning only when acknowledging MS group identity attachment/detachment.				

### 16.10.24 Group identity location demand

The group identity location demand information element shall be a collection of sub elements and defined in table 186.

**Table 186: Group identity location demand information element contents**

Information sub-element	Length	Type	C/O/M	Remark
Reserved	1	1	M	
Group identity attach/detach mode	1	1	M	
Group identity uplink		4	O	

### 16.10.25 Group identity location demand ack (void)

**Table 187: Group Identity Location Demand Ack information element contents (void)**

### 16.10.26 Group identity report

The group identity report information element shall indicate that all MS's active group identities must be reported as defined in table 188.

**Table 188: Group identity report information element contents**

Information element	Length	Value	Remark
Group identity report	1	0	Not report request
		1	Report request



## 16.10.27 Group identity uplink

The group identity uplink information element shall be a collection of sub elements and defined in table 189.

**Table 189: Group identity uplink information element contents**

Information sub-element	Length	Type	C/O/M	Remark
Group identity attach/detach type identifier	1	1	M	
Class of usage	3		C	see note 1
Group identity detachment uplink	2		C	see note 1
Group identity address type	2	1	M	
GSSI	24		C	see note 2
Address extension	24		C	see note 2
(V) GSSI	24		C	see note 2
NOTE 1: Shall be conditional on the value of Group Identity Attach/Detach Type Identifier (GIADTI): - GIADTI = 0; Class of Usage; - GIADTI = 1; Group Identity Detachment uplink.				
NOTE 2: Shall be conditional on the value of Group Identity Address Type (GIAT): - GIAT = 0; GSSI; - GIAT = 1; GSSI + Address Extension (GTSI); - GIAT = 2; Visitor Group Short Subscriber Identity ((V)GSSI); - GIAT = 3; Reserved.				

## 16.10.27a Group report response

The group report response information element shall indicate that the group report is complete as defined in table 189a.

**Table 189a: Group report response information element contents**

Information element	Length	Value	Remark
Group report response	1	0	Group report complete
		1	Reserved

## 16.10.28 Group Short Subscriber Identity (GSSI)

The GSSI information element shall indicate the GSSI or (V)GSSI that the MS shall use in subsequent contacts with the SwMI. It is also used during attachment/detachment to explicitly inform the full GTSI when used in conjunction with the extension element as defined in table 190.

**Table 190: GSSI information element contents**

Information element	Length	Value	Remark
GSSI	24		See EN 300 392-1 [9] clause 7

## 16.10.29 KSG number

For the KSG number information element refer to EN 300 392-7 [11].

**Table 191: KSG number information element contents (void)****16.10.30 LA**

The LA information element shall indicate the area in which a cell is located, either the serving cell or a neighbour cell as defined in table 192.

**Table 192: LA information element contents**

Information element	Length	Value	Remark
LA	14		

**16.10.31 LACC**

The LACC information element shall indicate which LACC the MS wants to use as defined in table 193. The element shall only be signalled if it is different from the country code used in the network, i.e. the MS is migrating.

**Table 193: Location Area Country Code information element contents**

Information element	Length	Value	Remark
Location Area Country Code	10		See EN 300 392-1 [9], clause 7 (MCC)

**16.10.32 LANC**

The LANC information element shall indicate which LANC the MS wants to use as defined in table 194. The element is only signalled if it is different from the network code used in the network, i.e. the MS is roaming.

**Table 194: LANC information element contents**

Information element	Length	Value	Remark
Location Area Network Code	14		See EN 300 392-1 [9] clause 7 (MNC)

**16.10.33 LA timer**

The LA timer information element shall indicate the time a LA is valid as defined in table 195.

**Table 195: LA timer information element contents**

Information element	Length	Value	Remark
LA timer	3	000 <sub>2</sub>	10 min
		001 <sub>2</sub>	30 min
		010 <sub>2</sub>	1 hour
		011 <sub>2</sub>	2 hours
		100 <sub>2</sub>	4 hours
		101 <sub>2</sub>	8 hours
		110 <sub>2</sub>	24 hours
		111 <sub>2</sub>	no timing

### 16.10.34 LA information

The LA information element shall be a collection of information elements as defined in table 196.

**Table 196: LA information element contents**

Information sub-element	Length	Type	C/O/M	Remark
Location Area (LA)	14	1	M	
Zero bit	1	1	M	

### 16.10.34a Length of the copied PDU

The Length of the copied PDU information element shall indicate the length of the Received PDU contents information element as defined in table 196A.

**Table 196A: Length of the copied PDU information element contents**

Information sub-element	Length	Value	Remark
Length of the copied PDU	8	00000000 <sub>2</sub>	0 bits
		00000001 <sub>2</sub>	1 bit
		00000010 <sub>2</sub>	2 bits
		...	etc.
		11111111 <sub>2</sub>	255 bits

### 16.10.35 Location update type

The purpose of the location updating type Information element shall indicate what type of registration is wanted as defined in table 197.

**Table 197: Location update type information element contents**

Information element	Length	Value	Remark
Location update type	3	000 <sub>2</sub>	Roaming location updating
		001 <sub>2</sub>	Migrating location updating
		010 <sub>2</sub>	Periodic location updating
		011 <sub>2</sub>	ITSI attach
		100 <sub>2</sub>	Call restoration roaming location updating
		101 <sub>2</sub>	Call restoration migrating location updating
		110 <sub>2</sub>	Demand location updating (D-Location Update command received)
		111 <sub>2</sub>	Disabled MS updating

### 16.10.35a Location update accept type

The location update accept type information element shall indicate the type of registration in the D-LOCATION UPDATE ACCEPT PDU as defined in table 197a.

**Table 197a: Location update accept type information element contents**

Information element	Length	Value	Remark
Location update type	3	000 <sub>2</sub>	Roaming location updating
		001 <sub>2</sub>	Temporary registration
		010 <sub>2</sub>	Periodic location updating
		011 <sub>2</sub>	ITSI attach
		100 <sub>2</sub>	Call restoration roaming location updating
		101 <sub>2</sub>	Migrating or call restoration migrating location updating
		110 <sub>2</sub>	Demand location updating (D-Location Update command received)
		111 <sub>2</sub>	Disabled MS updating

### 16.10.36 Mobile Country Code (MCC)

The MCC information element shall indicate to which MCC the MS is subscribed as defined in table 198.

**Table 198: MCC information element contents**

Information element	Length	Value	Remark
MCC	10		See EN 300 392-1 [9], clause 7 (MCC)

### 16.10.37 Mobile Network Code (MNC)

The MNC information element shall indicate to which MNC the MS is subscribed as defined in table 199.

**Table 199: MNC information element contents**

Information element	Length	Value	Remark
MNC	14		See EN 300 392-1 [9], clause 7 (MNC)

### 16.10.37a Mode change information

Mode change information element shall indicate additional information related to a direct mode or dual watch invocation as defined in table 199a.

**Table 199a: Mode change information element contents**

Information element	Length	Value	Remark
Mode change information	6	000000 <sub>2</sub>	Reserved
		...etc.	...etc.
		111111 <sub>2</sub>	Reserved

### 16.10.37b MS operating with type 2 repeater

The MS operating with type 2 repeater information element shall indicate whether the MS expects to use a type 2 Direct Mode repeater during its dual watch operation, as defined in table 199B. This may affect the appropriate energy economy groups (see EN 300 396-7 [38]).

**Table 199B: MS operating with type 2 repeater information element contents**

Information element	Length	Value	Remark
MS operating with type 2 repeater	1	0	MS does not expect to use a type 2 Direct Mode repeater
		1	MS expects to use a type 2 Direct Mode repeater

### 16.10.38 Multiframe Number (MN)

The Multiframe Number (MN) information element shall indicate TDMA multiframe number as defined in table 200.

**Table 200: Multiframe number information element contents**

Information element	Length	Value	Remark
Multiframe Number (MN)	6	000000 <sub>2</sub>	Reserved
		000001 <sub>2</sub>	MN1
		000010 <sub>2</sub>	MN2
		...etc.	...etc.
		111100 <sub>2</sub>	MN60
		111101 <sub>2</sub>	Reserved
		...etc.	...etc.
		111111 <sub>2</sub>	Reserved

### 16.10.38a Not-supported PDU type

See clause 16.10.39 PDU type element.

### 16.10.38b Number of frequency band definitions

The Number of the frequency band definitions information element shall indicate the how many frequency band definitions the PDU contains as defined in table 200A.

**Table 200A: Number of the frequency band definitions information element contents**

Information sub-element	Length	Value	Remark
Number of the frequency band definitions	3	000 <sub>2</sub>	0
		001 <sub>2</sub>	1
		010 <sub>2</sub>	2
		...etc.	etc.
		111 <sub>2</sub>	7

## 16.10.39 PDU type

The PDU type information element shall identify an up-link and down-link message. The PDU type information element shall have a separate definition in the uplink and downlink directions as defined in table 201.

**Table 201: PDU type information element contents**

Information element	Length	Value	Remark	
			Downlink	Uplink
PDU type	4	0000 <sub>2</sub>	D-OTAR, see EN 300 392-7 [11].	U-AUTHENTICATION, see EN 300 392-7 [11]
		0001 <sub>2</sub>	D-AUTHENTICATION, see EN 300 392-7 [11]	U-ITSI DETACH
		0010 <sub>2</sub>	D-CK CHANGE DEMAND, see EN 300 392-7 [11]	U-LOCATION UPDATE DEMAND
		0011 <sub>2</sub>	D-DISABLE, see EN 300 392-7 [11]	U-MM STATUS
		0100 <sub>2</sub>	D-ENABLE, see EN 300 392-7 [11]	U-CK CHANGE RESULT, see EN 300 392-7 [11]
		0101 <sub>2</sub>	D-LOCATION UPDATE ACCEPT	U-OTAR, see EN 300 392-7 [11]
		0110 <sub>2</sub>	D-LOCATION UPDATE COMMAND	Reserved
		0111 <sub>2</sub>	D-LOCATION UPDATE REJECT	U-ATTACH/DETACH GROUP IDENTITY
		1000 <sub>2</sub>	Reserved	U-ATTACH/DETACH GROUP IDENTITY ACK
		1001 <sub>2</sub>	D-LOCATION UPDATE PROCEEDING	U-TEI PROVIDE, see EN 300 392-7 [11]
		1010 <sub>2</sub>	D-ATTACH/DETACH GROUP IDENTITY	Reserved
		1011 <sub>2</sub>	D-ATTACH/DETACH GROUP IDENTITY ACK	U-DISABLE STATUS, see EN 300 392-7 [11]
		1100 <sub>2</sub>	D-MM STATUS	Reserved
		1101 <sub>2</sub>	Reserved	Reserved
		1110 <sub>2</sub>	Reserved	Reserved
1111 <sub>2</sub>	MM PDU/FUNCTION NOT SUPPORTED	MM PDU/FUNCTION NOT SUPPORTED		

## 16.10.40 New registered area

The new registered area information element shall be a collection of information elements as defined in table 202.

**Table 202: New registered area information element contents**

Information sub-element	Length	Type	C/O/M	Remark
LA timer	3	1	M	
LA	14	1	M	
LACC	10	2	O	see note
LANC	14	2	O	see note
NOTE: Not used in this version of the present document.				

## 16.10.41 Proprietary

Proprietary is an optional, variable length information element and shall be used to send and receive proprietary defined information appended to the PDUs.

The use, the size and the structure of the proprietary information element is outside the scope of the present document expect the first octet which shall indicate the owner of the proprietary information element as defined in annex H.

### 16.10.41a Reason for dual watch change by SwMI

The reason for dual watch change by SwMI information element shall inform the MS of the reason why the SwMI is changing the MS's dual watch operation, as defined in table 202a.

**Table 202a: Reason for dual watch change by SwMI information element contents**

Information element	Length	Value	Remark
Reason for dual watch change by SwMI	3	000 <sub>2</sub>	Dual watch terminated for undefined reason
		001 <sub>2</sub>	Change of dual watch energy economy group
		010 <sub>2</sub>	Reserved
		...etc.	...etc.
		111 <sub>2</sub>	Reserved

### 16.10.42 Reject cause

The reject cause information element shall indicate what type of rejection has been detected as defined in table 203.

**Table 203: Reject cause information element contents**

Information element	Length	Value	Remark
Reject cause	5	00000 <sub>2</sub>	Reserved
		00001 <sub>2</sub>	ITSI/ATSI unknown (system rejection)
		00010 <sub>2</sub>	Illegal MS (system rejection)
		00011 <sub>2</sub>	LA not allowed (LA rejection)
		00100 <sub>2</sub>	LA unknown (LA rejection)
		00101 <sub>2</sub>	Network failure (cell rejection)
		00110 <sub>2</sub>	Congestion (cell rejection)
		00111 <sub>2</sub>	Forward registration failure (cell rejection)
		01000 <sub>2</sub>	Service not subscribed (LA rejection)
		01001 <sub>2</sub>	Mandatory element error
		01010 <sub>2</sub>	Message consistency error
		01011 <sub>2</sub>	Roaming not supported (LA rejection)
		01100 <sub>2</sub>	Migration not supported (system rejection)
		01101 <sub>2</sub>	No cipher KSG
		01110 <sub>2</sub>	Identified cipher KSG not supported
		01111 <sub>2</sub>	Requested cipher key type not available
		10000 <sub>2</sub>	Identified cipher key not available
		10001 <sub>2</sub>	Reserved
		10010 <sub>2</sub>	Ciphering required
		10011 <sub>2</sub>	Authentication failure
		10100 <sub>2</sub>	Reserved
		...etc.	...etc.
		11111 <sub>2</sub>	Reserved

### 16.10.43 Request to append LA

The request to append LA information element shall indicate whether the MS user wants to append the new LA into the current registered area or not as defined in table 204.

**Table 204: Request to Append LA information element contents**

Information element	Length	Value	Remark
Request to append LA	1	0	No request to append LA to registered area (i.e. Registered area to include only this new LA)
		1	Request to append LA to registered area

### 16.10.43a Re-send interval

The re-send interval information element shall indicate the occasion when the MS should re-send the U-MS FREQUENCY BANDS INFORMATION PDU as defined in table 204a.

**Table 204a: Re-send interval information element contents**

Information element	Length	Value	Remark
Re-send interval	2	00 <sub>2</sub>	Re-sending not needed
		01 <sub>2</sub>	Re-send after each ITSI-Attach location update
		10 <sub>2</sub>	Re-send after each location update
		11 <sub>2</sub>	Reserved

### 16.10.43b Result of dual watch request

The result of dual watch request information element shall inform the MS of the result of its dual watch request as defined in table 204B.

**Table 204B: Result of dual watch request information element contents**

Information element	Length	Value	Remark
Result of dual watch request	3	000 <sub>2</sub>	Request rejected for undefined reason
		001 <sub>2</sub>	Dual watch not supported
		010 <sub>2</sub>	Request accepted with the dual watch energy economy group given in the "energy saving information" information element
		011 <sub>2</sub>	Reserved
		...etc.	...etc.
		111 <sub>2</sub>	Reserved

### 16.10.44 SSI

The SSI information element shall indicate the ASSI or (V)ASSI that the MS shall use in subsequent contacts with the SwMI as defined in table 205. It can also be used during registration to explicitly inform the SwMI of the full ITSI when used in conjunction with the MCC and MNC.

**Table 205: SSI information element content**

Information element	Length	Value	Remark
Short Subscriber Identity (SSI)	24		See EN 300 392-1 [9], clause 7



### 16.10.45 SCCH information

The SCCH information element shall assign parameters used by the MAC to calculate which CCCH to use when common SCCHs are in operation as defined in table 206.

**Table 206: SCCH information element contents**

Information element	Length	Value	Remark
SCCH information	4	0000 <sub>2</sub>	MS SCCH allocation 0
		0001 <sub>2</sub>	MS SCCH allocation 1
		...etc.	...etc.
		1011 <sub>2</sub>	MS SCCH allocation 11
		1100 <sub>2</sub>	Reserved
		...etc.	...etc.
		1111 <sub>2</sub>	Reserved

### 16.10.46 SCCH information and distribution on 18th frame

The SCCH information and distribution on 18th frame information element shall inform the MS of any SCCH information and on which of the 4 time slots the MS shall monitor down link information in the case of minimum mode as defined in table 207.

**Table 207: SCCH information and distribution on 18th frame information element contents**

Information sub-element	Length	Type	C/O/M	Remark
SCCH information	4	1	M	
Distribution on 18th frame	2	1	M	

### 16.10.47 SCK number

For the SCK number information element refer to EN 300 392-7 [11].

**Table 208: SCK number information element contents (void)**

### 16.10.47a Start of direct mode operation cause

Start of direct mode operation cause information element shall indicate the reason for entering direct mode operation as defined in table 208a.

**Table 208a: Start of direct mode operation cause information element contents**

Information element	Length	Value	Remark
Start of direct mode operation cause	3	000 <sub>2</sub>	User initiated mode change
		001 <sub>2</sub>	MS initiated mode change due to a potential loss of SwMI coverage
		010 <sub>2</sub>	MS initiated mode change due to SwMI load
		011 <sub>2</sub>	Reserved
		...etc.	...etc.
		111 <sub>2</sub>	Reserved

## 16.10.48 Status downlink

The status downlink information element shall indicate the requested service or a response to a request, and the sub-type of the D-MM STATUS PDU as defined in table 209.

**Table 209: Status downlink information element content**

Information element	Length	Value	Remark
Status downlink	6	000000 <sub>2</sub>	Reserved
		000001 <sub>2</sub>	Change of energy saving mode request
		000010 <sub>2</sub>	Change of energy saving mode response
		000011 <sub>2</sub>	Dual watch mode response
		000100 <sub>2</sub>	Terminating dual watch mode response
		000101 <sub>2</sub>	Change of dual watch mode request
		000110 <sub>2</sub>	Reserved (for an energy saving or dual watch purpose)
		000111 <sub>2</sub>	MS frequency bands request
		...etc.	...etc.
		001111 <sub>2</sub>	Reserved
		010000 <sub>2</sub>	Refer to ETS 300 396-5 [14]
		...etc.	...etc.
		011111 <sub>2</sub>	Refer to ETS 300 396-5 [14]
		100000 <sub>2</sub>	Available for TETRA network and user specific definitions
		...etc.	...etc.
		101111 <sub>2</sub>	Available for TETRA network and user specific definitions
		110000 <sub>2</sub>	Reserved
		...etc.	...etc.
111111 <sub>2</sub>	Reserved		

## 16.10.48a Status uplink

Status uplink information element shall indicate the requested service or a response to a request and the sub-type of the U-MM STATUS PDU as defined in table 209a.

**Table 209a: Status uplink information element content**

Information element	Length	Value	Remark
Status uplink	6	000000 <sub>2</sub>	Reserved
		000001 <sub>2</sub>	Change of energy saving mode request
		000010 <sub>2</sub>	Change of energy saving mode response
		000011 <sub>2</sub>	Dual watch mode request
		000100 <sub>2</sub>	Terminating dual watch mode request
		000101 <sub>2</sub>	Change of dual watch mode response
		000110 <sub>2</sub>	Start of direct mode operation
		000111 <sub>2</sub>	MS frequency bands information
		001000 <sub>2</sub>	Reserved
		...etc.	...etc.
		001111 <sub>2</sub>	Reserved
		010000 <sub>2</sub>	Refer to ETS 300 396-5 [14]
		...etc.	...etc.
		011111 <sub>2</sub>	Refer to ETS 300 396-5 [14]
		100000 <sub>2</sub>	Available for TETRA network and user specific definitions
		...etc.	...etc.
		101111 <sub>2</sub>	Available for TETRA network and user specific definitions
		110000 <sub>2</sub>	Reserved
...etc.	...etc.		
111111 <sub>2</sub>	Reserved		

## 16.10.49 Subscriber class

The subscriber class information element shall subdivide the MS population in up to 16 classes (see definition) represented as a bit map as defined in table 210.

**Table 210: Subscriber class information element**

Information element	Length	Value	Remark
Class 1	1	0	Not a member of class 1
		1	Member of class 1
Class 2	1	0	Not a member of class 2
		1	Member of class 2
...etc.	1	0	...etc.
		1	...etc.
Class 16	1	0	Not a member of class 16
		1	Member of class 16

## 16.10.50 TEI (void)

**Table 211: TEI information element content (void)**

## 16.10.51 Type 3/4 element identifier

The Type 3/4 element identifier information element shall indicate the type of the following Type 3/4 element in the PDU as defined in table 212.

**Table 212: Type 3/4 element identifier information element contents**

Information element	Length	Value	Remark
Type 3/4 element identifier	4	0000 <sub>2</sub>	Reserved
		0001 <sub>2</sub>	Default group attachment lifetime
		0010 <sub>2</sub>	New registered area
		0011 <sub>2</sub>	Group identity location demand
		0100 <sub>2</sub>	Group report response
		0101 <sub>2</sub>	Group identity location accept
		0110 <sub>2</sub>	DM-MS address, see ETS 300 396-5 [14] and EN 300 392-7 [11]
		0111 <sub>2</sub>	Group identity downlink
		1000 <sub>2</sub>	Group identity uplink
		1001 <sub>2</sub>	Authentication uplink, see EN 300 392-7 [11]
		1010 <sub>2</sub>	Authentication downlink, see EN 300 392-7 [11].
		1011 <sub>2</sub>	Reserved for any future specified Type 3/4 element
		...etc.	...etc.
		1110 <sub>2</sub>	Reserved for any future specified Type 3/4 element
1111 <sub>2</sub>	Proprietary		

## 16.10.52 (V)GSSI

The (V)GSSI information element shall indicate the (V)GSSI that the MS shall use in subsequent contacts with the SwMI as defined in table 213.

**Table 213: (V)GSSI information element contents**

Information element	Length	Value	Remark
Visitor Group Short Subscriber Identity	24		See EN 300 392-1 [9], clause 7

## 16.10.53 Zero bit

The Zero bit information element shall be as defined in table 213a.

**Table 213a: Zero bit information element contents**

Information element	Length	Value	Remark
Zero bit	1	0	This guarantees the backward compatibility to edition 1

## 16.11 Parameters

### 16.11.1 Timers

#### 16.11.1.1 Timer T351: Registration response time

This shall be the maximum time MM is waiting for a response for a registration request. The timer T351 value shall be 10 s.

#### 16.11.1.2 Timer T352: Energy mode response time

This shall be the maximum time MM is waiting for a response for an energy saving or dual watch mode request. The timer T352 value shall be 30 s.

#### 16.11.1.3 Timer T353: Attach/Detach response time

This shall be the maximum time MM is waiting for a response for a U-Attach/Detach Group Identity PDU. The timer T353 value shall be 30 s.

---

## 17 MLE service description

### 17.1 Introduction

This clause describes the services offered by the MLE.

The assumed underlying protocol is a MLE protocol, which is assumed to be positioned in the lowest sub-layer of layer 3 of the air interface stack.

The MLE services are provided through a set of SAPs, with each SAP corresponding to one type of service user (one upper layer 3 protocol).

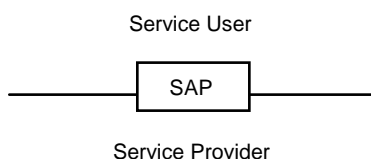
The MLE protocol has been designed to hide most of the radio aspects of the air interface, and the resulting MLE services are intended to be comparable to non-radio (line) layer 2 protocols.

**NOTE:** Identical service definitions should also be used for LSs to allow the use of identical upper layer 3 protocols in LSs.

The MLE service boundary is an internal sub-layer boundary that is defined to clarify the description of the air interface layer 3. It is not intended to be a testable boundary. Conformance to this service should be achieved by providing conformance to one of the assumed MLE protocols.

## 17.2 Summary of services offered by MLE protocol

The MLE provides services to MLE service users. These services should be made available through SAPs. This relationship is shown in figure 59B.



**Figure 59B: Relationship between a service user and a service provider**

The entities listed below shall be permitted to use MLE services:

- Mobility Management (MM) entity (see clause 16);
- Circuit Mode Control Entity (CMCE) (see clause 14);
- Subnetwork Dependent Convergence Protocol (SNDCP) entity (see clause 28).

All of the permitted MLE service users need not be present. However, in order that the MLE services may be requested, at least some of the permitted MLE service users should be present. For example, a V+D MS may choose not to implement the SNDCP entity. The MLE shall not be required to support the MLE service users which are not present.

The MLE services are represented by the set of MLE service primitives which are available via the various SAPs listed in table 214.

**Table 214: MLE SAPs**

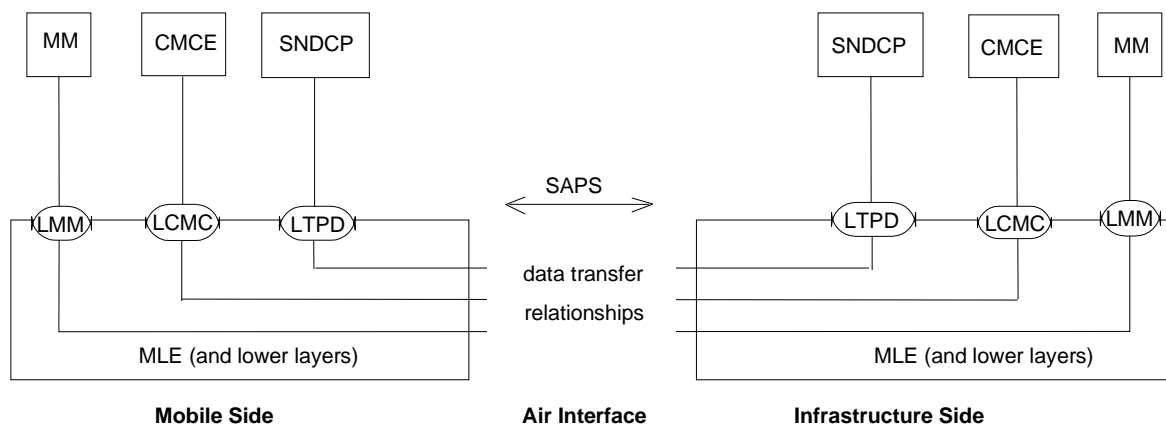
SAP name	Upper layer 3 protocol (service user)	Reference
LMM-SAP	Mobility Management (MM)	clauses 17.3.1 and 17.3.2
LCMC-SAP	Circuit Mode Control Entity (CMCE)	clauses 17.3.3 and 17.3.4
LTPD-SAP	Subnetwork Dependent Convergence Protocol (SNDCP)	clauses 17.3.5 and 17.3.6

With the exception of the LMM-SAP, the services offered at each SAP should be independent of each other, and the service at each of the other SAPs should operate using an independent set of primitives. The LMM-SAP can act as a "master SAP", enabling and disabling service provision at the other SAPs.

The LTPD-SAP may support multiple independent instances of higher protocol (multiple instances of SNDCP, each with an independent set of primitives) but each instance must be associated with a different TSI family. All TSI families associated with SNDCP within 1 MS/LS shall be associated with a single instance of MM protocol.

NOTE: Multiple TSI families are the normal situation on the TETRA infrastructure side. Most MSs contain only one TSI family, but multiple TSI families may co-exist in one MS (see EN 300 392-1 [9], clause 7).

Figure 60 shows the service relationships relating to the MLE services.



**Figure 60: Services relationships offered by the MLE in the air interface**

## 17.3 Service descriptions

The following service descriptions describe the MLE services provided to the higher layers in the MS protocol stack. The services are described for the protocol model purposes and present no testable requirements.

### 17.3.1 Service state diagram for the LMM-SAP

The primitives provided by the MLE to the MM entity shall be as shown in table 215.

**Table 215: Primitives and parameters at the LMM-SAP**

Primitives generic name	Specific name	Parameters
MLE-ACTIVATE	request	List of MCC List of MNC
	confirm	Registration required LA
	indication	-
MLE-ACTIVITY	request	Sleep mode
MLE-BUSY	request	-
MLE-CANCEL	request	Handle
MLE-CONFIGURE	request	Periodic reporting timer

Primitives generic name	Specific name	Parameters
MLE-CLOSE	request	-
MLE-DEACTIVATE	request	-
MLE-IDENTITIES	request	ISSI ASSI Attached GSSIs Detached GSSIs
MLE-IDLE	request	-
MLE-INFO	request	Subscriber class SCCH configuration Energy economy mode configuration Minimum mode configuration Dual watch mode configuration
	indication	Broadcast parameters Subscriber class match
MLE-LINK	request	MCC MNC List of LA
	indication	MCC MNC LA Registration type Security parameters
MLE-OPEN	request	-
MLE-PREPARE	request	SDU Handle layer 2 service PDU priority Stealing permission Stealing repeats flag
	confirm	SDU Handle
MLE-REPORT	indication	Handle Transfer result
MLE-UNITDATA	request	SDU Handle Address type Address layer 2 service PDU priority Stealing permission Stealing repeats flag Encryption flag Null PDU, see note
	indication	SDU Handle Received address Received address type
MLE-UPDATE	request	MCC MNC RA Registration result
NOTE: When a null PDU is indicated then the PDU priority shall be the lowest value and stealing shall not be permitted. The other parameters are not applicable with a null PDU.		

The transactions between the states shall be as shown in figure 61.

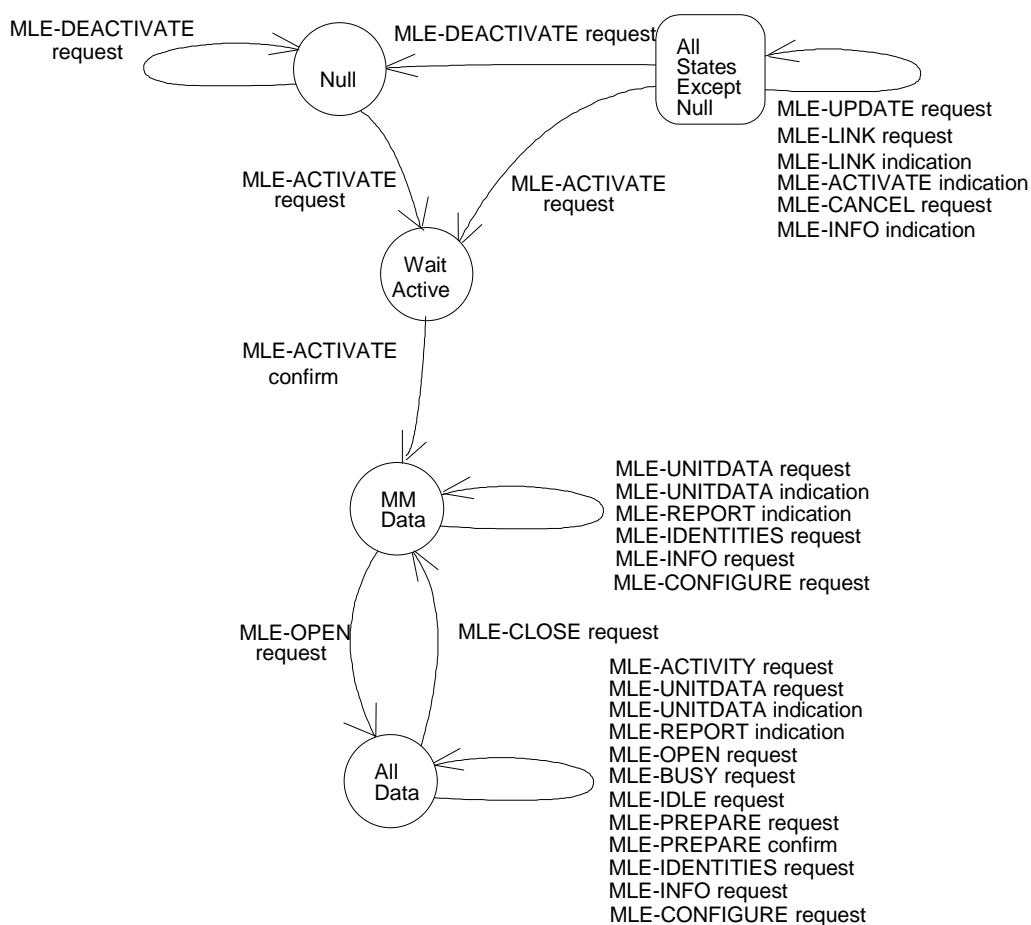


Figure 61: LMM-SAP state transition diagram

### 17.3.2 Service primitives for the LMM-SAP

**MLE-ACTIVATE request:** this shall be used as a request to initiate the selection of a cell for communications. The request shall always be made after power on and may be made at any time thereafter.

**MLE-ACTIVATE confirm:** this shall be used as a confirmation to the MM entity that a cell has been selected with the required characteristics.

**MLE-ACTIVATE indication:** this shall be used as an invitation to the MM to react as no suitable cell is available.

**MLE-ACTIVITY request:** this shall be used by the MM entity to inform the MLE that the MS must "stay alive" or if sleeping is permitted. It is used during a signalling exchange with the SwMI, which requires a layer 3 response.

**MLE-BUSY request:** this shall be used by the MM entity to indicate to MLE that a MM protocol exchange is in progress.

**MLE-CANCEL request:** this may be used by the MM to delete a previous request issued but not yet transmitted. The ability to cancel shall be removed when the MLE-REPORT indication is received, indicating transmission of the MM PDU.

**MLE-CLOSE request:** this shall be used by the MM entity to instruct the MLE to remove access to communication resources for the other layer 3 entities, but keeping access to the communication resources for the MM entity.

**MLE-CONFIGURE request:** this primitive shall be used by the MM entity to pass inter layer management information relating to mobility management.



**MLE-DEACTIVATE request:** this shall be used by the MM entity to request the de-activation of all MLE procedures and to return to the NULL state. No communication resources are available for use after this primitive has been issued.

**MLE-IDENTITIES request:** this primitive shall be used to transfer the identities that have been received from the SwMI to the MLE, and layer 2.

**MLE-IDLE request:** this shall be used by the MM entity to indicate to MLE that a MM protocol exchange has completed.

**MLE-INFO request:** this primitive shall be used to transfer control parameters received from the SwMI to the MLE and layer 2. These control parameters include information on energy economy modes, control channel configurations and subscriber class.

**MLE-INFO indication:** this primitive shall be used by MLE to inform the MM of a change in system broadcast parameters or to indicate whether there is any match between the subscriber class being broadcast by the SwMI and the subscriber class of the MS.

**MLE-LINK request:** this shall be used by the MM entity to request that MLE select a specified MCC, MNC and possible LA.

**MLE-LINK indication:** this shall be used by the MLE to indicate to the MM entity that the MS has selected or is about to select a cell and registration is needed on the new cell, or the MS is required to re-register on the current cell.

**MLE-OPEN request:** this shall be used by the MM entity to instruct the MLE to provide access to communication resources for other layer 3 entities after successful registration.

**MLE-PREPARE request:** this shall be used by the MM entity to instruct the MLE to forward register during announced type 1 cell reselection.

**MLE-PREPARE confirm:** this shall be used by the MLE to confirm forward registration during announced type 1 cell reselection.

**MLE-REPORT indication:** this shall be used by the MLE to report on the completion of an MLE-UNITDATA request procedure. The result of the transfer attempt is passed as a parameter. Errors detected during the MLE-UNITDATA request procedure are indicated using this primitive.

**MLE-UNITDATA request:** this shall be used by the MM entity to request a data transmission A parameter indicates which layer 2 service is required.

**MLE-UNITDATA indication:** this shall be used by the MLE to pass to the MM entity data which has been received from the SwMI.

**MLE-UPDATE request:** this shall be used by the MM entity to inform the MLE about new criteria concerned with the monitoring of other possible cells.

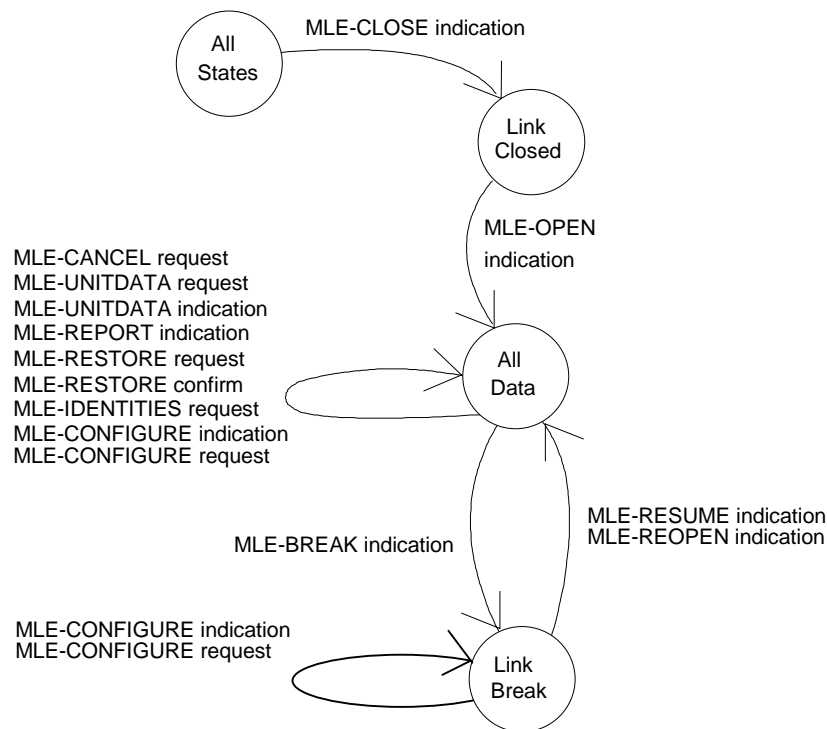
### 17.3.3 Service state diagram for the LCMC-SAP

The primitives provided by the MLE to the CMCE shall be as shown in table 216.

**Table 216: Primitives and parameters at the LCMC-SAP**

Generic name	Specific name	Parameters
MLE-ACTIVITY	request	Call state
MLE-BREAK	indication	-
MLE-BUSY	indication	-
MLE-CANCEL	request	Handle
MLE-CLOSE	indication	-
MLE-CONFIGURE	request	Endpoint identifier Channel change accepted Channel change handle Call release Encryption flag Circuit mode type Simplex/duplex Add temporary GSSI Delete temporary GSSI Tx grant Switch U Plane
MLE-CONFIGURE	indication	Endpoint identifier Channel change response required Channel change handle Reason for configuration indication Conflicting endpoint identifier
MLE-IDENTITIES	request	List of GSSIs
MLE-IDLE	indication	-
MLE-INFO	indication	Broadcast parameters Subscriber class match
MLE-OPEN	indication	MCC (current network) MNC (current network)
MLE-REOPEN	indication	-
MLE-REPORT	indication	Handle Transfer result Channel change response required Channel change handle
MLE-RESTORE	request	SDU Handle layer 2 service PDU priority Stealing permission Stealing repeats flag
	confirm	SDU Handle
MLE-RESUME	indication	MCC (current network) MNC (current network)
MLE-UNITDATA	request	SDU Handle Endpoint identifier layer 2 service PDU priority Quality of Service Stealing permission Stealing repeats flag
	indication	SDU Handle Endpoint identifier Received TETRA address (ITSI/GTSI) Received address type Channel change response required Channel change handle

The state transitions visible at this SAP shall be as shown in figure 62.



**Figure 62: State transition diagram of LCMC-SAP**

### 17.3.4 Service primitives for LCMC-SAP

**MLE-ACTIVITY request:** this primitive shall be used by the CMCE to inform the MLE of the state of any circuit mode call(s).

**MLE-BREAK indication:** this primitive shall be used by the MLE to inform the CMCE that access to the communication resources is temporarily unavailable and that the data transfer service cannot be used.

**MLE-BUSY indication:** this shall be used by the MLE to inform the CMCE that a MM protocol exchange is in progress.

**MLE-CANCEL request:** this primitive shall be used by the CMCE to delete a previous request issued but not yet transmitted. The ability to cancel shall be removed when the MLE-REPORT indication is received, indicating successful or first complete transmission of the CMCE PDU.

**MLE-CLOSE indication:** this primitive shall be used by the MLE to indicate to the CMCE that access to the communications resources has been removed and that data transfer service cannot be used.

**MLE-CONFIGURE request:** this primitive shall be used to pass inter layer management information relating to circuit mode calls, e.g. whether Tx grant has been given, type of traffic etc.

**MLE-CONFIGURE indication:** this primitive shall be used to pass inter layer management information relating to circuit mode calls and packet data conflicts.

**MLE-IDENTITIES request:** this primitive shall be used by the CMCE to inform the MLE and layer 2 of a change to the list of group identities.

**MLE-IDLE indication:** this shall be used by the MLE to inform the CMCE that a MM protocol exchange has completed.

**MLE-INFO indication:** this primitive shall be used by MLE to inform the CMCE of a change in system broadcast parameters or to indicate whether there is any match between the subscriber class being broadcast by the SwMI and the subscriber class of the MS.

**MLE-OPEN indication:** this primitive shall be used by the MLE to inform the CMCE that it has access to the communication resources and that the data transfer service can be used.

**MLE-REOPEN indication:** this primitive shall be used by the MLE to inform the CMCE that access to the communication resources is once again available. MLE-REOPEN indication indicates the failure of current call restoration to CMCE but does not prevent CMCE from restoring other circuit-mode calls. The data transfer service can now be used.

**MLE-REPORT indication:** this shall be used by the MLE to report on the completion of an MLE-UNITDATA request procedure. The result of the transfer attempt shall be passed as a parameter.

**MLE-RESTORE request:** this primitive shall be used by the CMCE to restore a call after a successful cell reselection.

**MLE-RESTORE confirm:** this primitive indicates the success or failure of call restoration to the CMCE as a result of a previously issued MLE-RESTORE request.

**MLE-RESUME indication:** this primitive shall be used by the MLE to inform the CMCE that access to the communication resources is once again available. The data transfer service can now be used and the CMCE may attempt to restore any circuit mode calls.

**MLE-UNITDATA request:** this primitive shall be used by the CMCE to send unconfirmed data to a peer entity on the TETRA infrastructure side. Parameter indicates which layer 2 service is required.

**MLE-UNITDATA indication:** this primitive shall be used by the MLE to pass to the CMCE entity data which has been received from a peer entity on the TETRA infrastructure side.

### 17.3.5 Service state diagram for the LTPD-SAP

The primitives provided by the MLE to the SNDCP entities shall be as shown in table 217.

**Table 217: Primitives and parameters at the LTPD-SAP**

Generic name	Specific name	Parameters
MLE-ACTIVITY	request	Sleep mode
MLE-BREAK	indication	-
MLE-BUSY	indication	-
MLE-CLOSE	indication	-
MLE-CONFIGURE	request	Channel change accepted Channel change handle Call release Endpoint identifier Encryption flag
MLE-CONFIGURE	indication	Endpoint identifier Channel change response required Channel change handle Reason for configuration indication Conflicting endpoint identifier
MLE-CONNECT	request	Address Endpoint identifier Resource request PDU priority Quality of Service Encryption flag Setup report
	indication	Address Endpoint identifier New endpoint identifier Quality of Service Encryption flag Channel change response required Channel change handle Setup report

Generic name	Specific name	Parameters
	response	Address Endpoint identifier PDU priority Stealing permission Quality of Service Encryption flag Setup report
	confirm	Address Endpoint identifier Quality of Service Encryption flag Channel change response required Channel change handle Setup report
MLE-DISCONNECT	request	Endpoint identifier PDU priority Encryption flag Report
	indication	Endpoint identifier New endpoint identifier Encryption flag Channel change response required Channel change handle Report
MLE-INFO	indication	Broadcast parameters Subscriber class match
MLE-IDLE	indication	-
MLE-OPEN	indication	MCC (current network) MNC (current network)
MLE-RECEIVE	indication	Endpoint identifier Received TETRA address (ITSI/GTSI) Received address type
MLE-RECONNECT	request	Endpoint identifier Resource request PDU priority Encryption flag Stealing permission
	confirm	Endpoint identifier; New endpoint identifier; Encryption flag; Report; Reconnection result
	indication	Endpoint identifier; New endpoint identifier; Encryption flag; Report; Reconnection result
MLE-RELEASE	request	Endpoint identifier
MLE-REPORT	indication	Handle Transfer result
	confirm	Quality of Service
MLE-RESUME	indication	MCC (current network) MNC (current network)
MLE-UNITDATA	request	SDU Handlelayer 2 service PDU priority Quality of Service Endpoint identifier Stealing permission Stealing repeats flag
	indication	SDU Endpoint identifier Received TETRA address (ITSI/GTSI) Received address type Channel change response required Channel change handle

The state transitions visible at the LTPD-SAP should be as shown in figure 63.

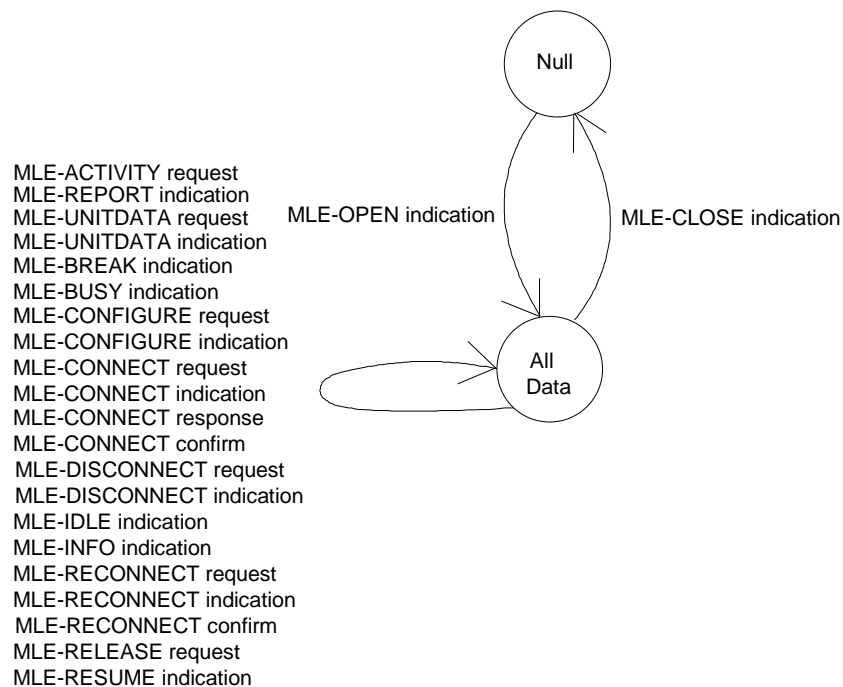


Figure 63: State transition diagram of LTPD-SAP

### 17.3.6 Service primitives for LTPD-SAP

The service primitives at the LTPD-SAP shall be the following:

**MLE-ACTIVITY request:** this primitive shall be used by the SNDTCP to inform the MLE that the MS must "stay alive" or if "sleeping is permitted". It is used during MS initiated signalling exchanges with the SwMI.

**MLE-BREAK indication:** this shall be used by the MLE to inform the SNDTCP entity that the resources needed for communication are temporarily not available. This can be due to a lower layer failure, or due to a MLE controlled cell change.

**MLE-BUSY indication:** this shall be used by the MLE to inform the SNDTCP entity that a MM protocol exchange is in progress.

**MLE-CLOSE indication:** this shall be used by the MLE to indicate to the SNDTCP entity that access to the communications resources has been removed and the SNDTCP entity is not permitted to communicate with its peer entity.

**MLE-CONFIGURE request:** this primitive shall be used by the SNDTCP entity to pass inter layer management information relating to packet data.

**MLE-CONFIGURE indication:** this primitive shall be used to pass inter layer management information relating to circuit mode calls and packet data conflicts.

**MLE-CONNECT request:** this primitive shall be used by the SNDTCP entity to convey QoS parameters used in the advanced link set-up. It also shall be used to trigger the MLE to reset the advanced link. It also applies as a cancel request which deletes previous requests issued and not yet transmitted.

**MLE-CONNECT indication:** this primitive shall be used by the MLE entity to inform the SNDTCP entity that the establishment of an advanced link with a certain quality of service or the reset of the current advanced link has been requested.

**MLE-CONNECT response:** this primitive may be used by the SNDTCP entity to accept the establishment or reset of the advanced link with a certain quality of service. According to the available resources, the value of the service parameters may be modified (lower grade of service) in the response. In such a case the advanced link characteristics will match these new features.

**MLE-CONNECT confirm:** this primitive shall be used by the MLE entity to inform the SNDCP entity that the establishment or reset of the advanced link has been completed with a certain quality of service as indicated in the confirm primitive.

**MLE-DISCONNECT request:** this primitive shall be used by the SNDCP entity to trigger MLE to disconnect the advanced link. It also applies as a CANCEL Request which deletes previous requests issued and not yet transmitted

**MLE-DISCONNECT indication:** this primitive shall be used by the MLE entity to inform the SNDCP entity on advanced link disconnection for any reason.

**MLE-IDLE indication:** this shall be used by the MLE to inform the SNDCP entity that a MM protocol exchange has completed.

**MLE-INFO indication:** this primitive shall be used by MLE to inform the SNDCP of a change in system broadcast parameters or to indicate whether there is any match between the subscriber class being broadcast by the SwMI and the subscriber class of the MS.

**MLE-OPEN indication:** this primitive shall be used by the MLE to inform the SNDCP that it has access to the communication resources and that the data transfer service can be used.

**MLE-RECEIVE indication:** this primitive shall be used by the MLE entity to inform the SNDCP entity that the reception of data from the peer entity on the LLC has started or is ongoing. This primitive is valid for SwMI only.

**MLE-RECONNECT request:** this primitive shall be used by the MS SNDCP entity after cell reselection to request the reconnection of the advanced link.

**MLE-RECONNECT confirm:** this primitive shall be used by the MS MLE entity to inform the SNDCP entity of the success or failure of an attempt to reconnect the advanced link.

**MLE-RECONNECT indication:** this primitive shall be used by the SwMI MLE entity to inform the SNDCP entity of the success or failure of an attempt by a MS to reconnect an advanced link.

**MLE-RELEASE request:** this primitive shall be used by the MS SNDCP entity to request the local disconnection of an advanced link.

**MLE-REPORT indication:** this shall be used by the MLE to report on the completion of a MLE-UNITDATA request procedure. The result of the transfer attempt shall be passed as a parameter. Errors detected during the MLE-UNITDATA request procedure shall be indicated using this primitive.

**MLE-RESUME indication:** this shall be used to indicate that a temporary break in access to the communications resources has been recovered. All previous MLE associations between peer MLE entity have been successfully recovered.

**MLE-UNITDATA request:** this shall be used by the SNDCP entity to send data to a peer entity. Parameters indicate whether layer 2 acknowledged or unacknowledged service is required.

**MLE-UNITDATA indication:** this shall be used by the MLE to pass to the SNDCP entity data which has been received from a peer entity.

### 17.3.7 (Void)

**Table 218: (Void)**

**Table 219: Void**

**Figure 64: (Void)**

## 17.3.8 (Void)

## 17.3.9 Parameter summary

The following list summarises the parameters used in the primitives described in this clause.

- Add temporary GSSI =
  - GSSI.
- Address =
  - TETRA address (ISSI,ASSI or USSI).
- Address type =
  - individual short subscriber identity (ISSI);
  - aliased short subscriber identity (ASSI);
  - unexchanged short subscriber identity (USSI).
- ASSI =
  - TETRA address.
- Attached GSSIs =
  - TETRA address.
- Broadcast parameters =
  - Broadcast information extracted from SYSINFO PDU. Refer to clauses 18.4.2.2 and 21.4.4.1.
- Call release =
  - true;
  - false.
- Call state =
  - idle;
  - group call with transmit permission;
  - group call without transmit permission;
  - individual call with transmit permission;
  - individual call without transmit permission.
- Channel change accepted =
  - accept;
  - reject;
  - ignore.
- Channel change handle =
  - an identifier of a "channel change response required" request.



- Channel change response required =
  - true;
  - false.
- Circuit mode type =
  - speech (TCH/S);
  - unprotected data (TCH/7,2);
  - low protection data (TCH/4,8), N = 1 ;
  - low protection data (TCH/4,8), N = 4 ;
  - low protection data (TCH/4,8), N = 8 ;
  - high protection data (TCH/2,4), N = 1 ;
  - high protection data (TCH/2,4), N = 4 ;
  - high protection data (TCH/2,4), N = 8 .
- Conflicting endpoint identifier =
  - conflicting radio resource identifier.
- Delete temporary GSSI =
  - GSSI.
- Detached GSSIs =
  - TETRA address(es).
- Dual watch mode configuration =
  - a set of group (0 to 7), start frame (1 to 18) and start multiframe (1 to 60).
- Encryption flag =
  - on;
  - off.
- Endpoint identifier =
  - radio resource identifier.
- Energy economy mode configuration =
  - a set of group (0 to 7), start frame (1 to 18) and start multiframe (1 to 60).
- Handle
  - a local SDU identifier.
- ISSI =
  - TETRA address.

- layer 2 service =
  - acknowledged request;
  - acknowledged response;
  - unacknowledged.
- List of GSSIs =
  - TETRA address(es).
- List of LA.
- LA.
- Minimum mode configuration =
  - frame 18 slot (1 to 4).
- MCC (see EN 300 392-1 [9], clause 7).
- MNC (see EN 300 392-1 [9], clause 7).
- New endpoint identifier:
  - a new endpoint identifier shall refer to a new resource allocation (typically in addition to an existing resource allocation).
- Null PDU =
  - a null PDU is due to sending;
  - an SDU is due to sending.
- PDU priority =
  - eight possible values, 0...7.
- Periodic reporting timer =
  - no reporting / stop reporting;
  - values 15 s to 31 min 45 s.
- Quality of Service (QoS) =
  - throughput.
- RA =
  - a set of one or more LAs.
- Reason for configuration indication =
  - reception stopped;
  - transmission stopped;
  - usage marker mismatch;
  - loss of radio resources;
  - recovery of radio resources.
- Received TETRA address =
  - TETRA address (ITSI or GTSI).

- Received address type =
  - individual allocated identity (ITSI);
  - individual un-exchanged identity (ITSI);
  - group (GTSI).

NOTE 1: The individual un-exchanged identity is valid only in some migration PDUs, refer to clause 23.4.1.2.5.

- Reconnection result =
  - success;
  - reject.
- Registration type =
  - normal;
  - forward;
  - periodic.
- Registration required =
  - true;
  - false.
- Registration Result =
  - success;
  - Cell rejection;
  - LA rejection;
  - system rejection;
  - forward registration failure;
  - temporary registration.
- Resource request =
  - amount of data available for sending, refer to clause 28.3.4.2 a).
- Report
  - report shall generally indicate the progress of information transfer. Refer to clause 20.2.4.33.
- Set-up report =
  - this shall be used to report on the setup phase of an advanced link.
- SCCH configuration =
  - 0 - 11.
- SDU.
- Security parameters =
  - Security related broadcast information extracted from SYSINFO PDU. Refer to see EN 300 392-7 [11].

- Simplex/duplex =
  - simplex;
  - duplex.
- Sleep mode =
  - stay alive;
  - sleep permitted.
- Stealing permission =
  - steal immediately;
  - steal when convenient;
  - stealing not required.
- Stealing repeats flag =
  - set;
  - not set.
- Subscriber class
  - a set of classes 1 to 16.
- Subscriber class match =
  - true;
  - false.
- Switch U-plane =
  - on;
  - off.
- Transfer result =
  - success, more data in the LLC buffer;
  - success, LLC buffer empty;
  - failure, data item removed from LLC buffer;
  - transfer rejected due to an emergency call.
- Tx-grant =
  - true;
  - false.

---

## 18 MLE protocol

### 18.1 Introduction

This clause defines the protocol for the V+D MLE. This shall be the lowest sub-layer of the network layer as described in EN 300 392-1 [9]. It may be used to provide sub-network services to higher network layer entities at the air interface according to the MLE service description (see clause 17). This clause defines the MLE protocol functions required for MS operation.

This clause specifies:

- the protocol procedures;
- the protocol services;
- the PDUs and associated elements.

See clause 17 for the MLE service description (SAPs, services and primitives).

### 18.2 Overview of the sub-layer

The MLE protocol should be used to mask mobility and radio resources from the higher entities.

It shall provide a sub-network dependent protocol (convergence) and a sub-network access protocol to the V+D layer 2 (see clause 20).

#### 18.2.1 Protocol environment

The V+D MLE shall be the layer 3, sub-layer 3.1 which provides services to the layer 3, sub-layer 3.2, as shown in figure 65. This protocol shall provide services to the following higher entities:

- MM entity (see clause 16);
- CMCE entity (see clause 14);
- SNDCCP entity (see clause 28).

The MLE services shall be represented by the MLE service primitives which shall apply to the following SAPs:

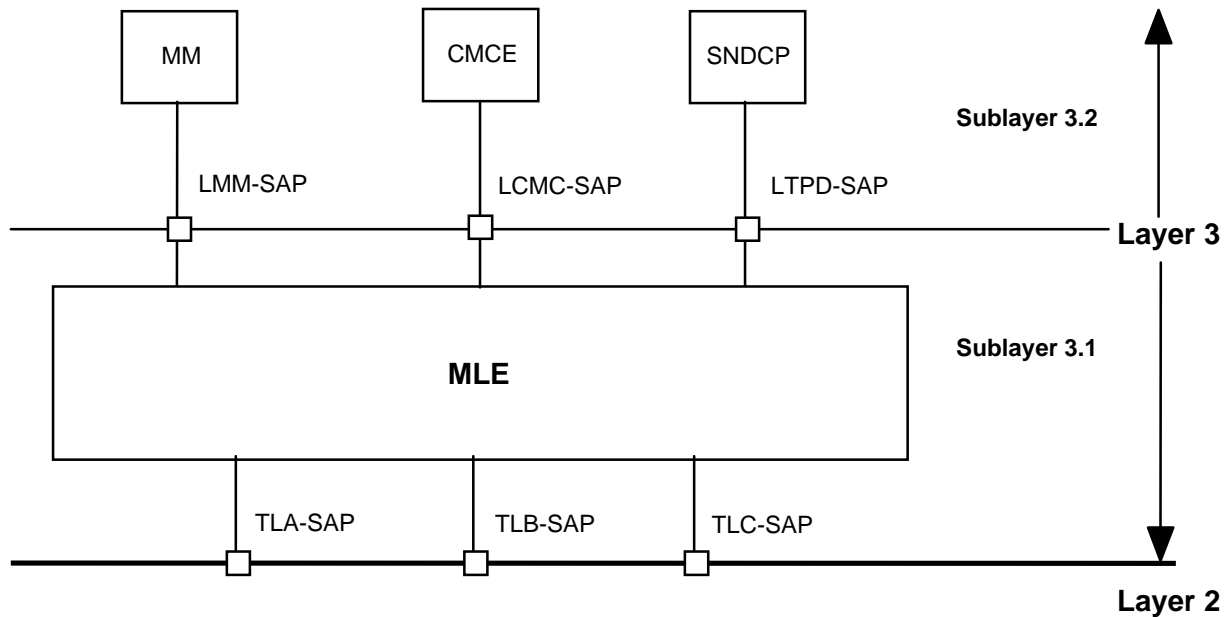
- LCMC-SAP for CMCE;
- LTPD-SAP for SNDCCP; and
- LMM-SAP for MM.

The services offered at the MM SAP may interact with the services offered at the CMCE and SNDCCP SAPs.

The underlying protocol should be the V+D layer 2 (see clauses 22 and 23).

The MLE protocol may also interface to the Lower Layer Management Entity (LLME) and the interface is defined by the C-SAP. However, the exact implementation of the interface is outside the scope of the present document.

The protocol architecture can be similar on the BS side of the air interface.



**Figure 65: The MLE (sub-layer 3.1) in the MS protocol stack**

The MS-MLE shall establish the basis for communication with a cell (BS) by camping on the cell and the MS-MLE shall check the quality using the information received from the layer 2. Once the cell has been found suitable by the MS-MLE, the MM entity may intervene in order to register the MS. When the cell has been registered, the MS is said to be attached and the MLE can now offer data transfer services to the CMCE and SNDCP entities as well. Data transfer shall be regulated by the MM entity which may allow access for MM only or for all entities.

The MLE shall perform surveillance of the quality of the radio communication path. It may report any break or loss of the path and, when necessary it should try to re-establish the communication with the same or another BS in either the same or a different LA.

## 18.2.2 Services and primitives offered by the MLE to the MM entity

The services and primitives offered to the MM entity are described in clause 17.

The services offered shall be:

- a) activation of MLE procedures:
  - MLE-ACTIVATE request/confirm/indication.
- b) opening of link access to other layer 3 entities:
  - MLE-OPEN request.
- c) data transfer:
  - MLE-UNITDATA request/indication;
  - MLE-REPORT indication.
- d) closing the access to other entities:
  - MLE-CLOSE request.
- e) deactivation of the MLE procedures:
  - MLE-DEACTIVATE request.

- f) information on a network, cell or LA:
  - MLE-LINK request/indication.
- g) updating current registered area:
  - MLE-UPDATE request.
- h) cancellation of issued primitive requests:
  - MLE-CANCEL request.
- i) informing MLE that MM signalling exchange is in progress:
  - MLE-BUSY request.
- j) informing MLE that MM signalling exchange has completed:
  - MLE-IDLE request.
- k) performing forward registration during cell reselection:
  - MLE-PREPARE request/confirm.
- l) exchange of information between layers:
  - MLE-IDENTITIES request;
  - MLE-INFO request/indication.

### 18.2.3 Services and primitives offered by the MLE to the CMCE entities

The services and primitives offered to the CMCE entity are described in clause 17.

The services offered shall be:

- a) indication that access to resources is enabled:
  - MLE-OPEN indication.
- b) indication that access to resources is disabled:
  - MLE-CLOSE indication.
- c) indicating a temporary break in the access to the communication resources:
  - MLE-BREAK indication.
- d) indicating resumption (or reopening) in the access to the communication resources:
  - MLE-RESUME indication;
  - MLE-REOPEN indication.
- e) restoration of circuit mode calls after cell reselection:
  - MLE-RESTORE request/confirm.
- f) data transfer:
  - MLE-UNITDATA request/indication;
  - MLE-REPORT indication.
- g) cancellation of issued primitive requests:
  - MLE-CANCEL request.

- h) exchange of information between layers:
  - MLE-CONFIGURE request;
  - MLE-CONFIGURE indication;
  - MLE-IDENTITIES request;
  - MLE-INFO indication.
- i) indicating that MM signalling exchange is in progress:
  - MLE-BUSY indication.
- j) indicating that MM signalling exchange has completed:
  - MLE-IDLE indication.

## 18.2.4 Services and primitives offered by the MLE to the SNDTCP entity

The services and primitives offered to the SNDTCP entity are described in clause 17.

The service offered shall be:

- a) indication that access to resources is enabled:
  - MLE-OPEN indication.
- b) indication that access to resources is disabled:
  - MLE-CLOSE indication.
- c) indicating a temporary break in the access to the communication resources:
  - MLE-BREAK indication.
- d) indicating resumption in the access to the communication resources:
  - MLE-RESUME indication.
- e) advanced link setup/ advanced link reset:
  - MLE-CONNECT request/indication/response/confirm.
- f) advanced link disconnection:
  - MLE-DISCONNECT request/indication;
  - MLE-RELEASE request.
- g) data transfer:
  - MLE-UNITDATA request/indication;
  - MLE-RECEIVE indication;
  - MLE-REPORT indication.
- h) exchange of information between layers:
  - MLE-CONFIGURE request;
  - MLE-CONFIGURE indication;
  - MLE-INFO indication.



- i) advanced link reconnection:
  - MLE-RECONNECT request/indication/confirm.
- j) indicating that MM signalling exchange is in progress:
  - MLE-BUSY indication.
- k) indicating that MM signalling exchange has completed:
  - MLE-IDLE indication.

### 18.2.5 (Void)

### 18.2.6 Services and primitives offered by layer 2 to MLE

Layer 2 shall provide the MLE with different services, which enable the MLE to provide the services requested by its services users. The following primitives are defined for that purpose.

On the TLA-SAP the following services and primitives should be available (see clause 20 for service definitions):

- a) establishing a data link connection by using the LLC advanced link mechanism:
  - TL-CONNECT request/indication/response/confirm.
- b) transfer of data using a layer 2 acknowledged service:
  - TL-DATA request/indication/response/confirm.
- c) disconnection of an established data link connection, i.e. an LLC advanced link:
  - TL-DISCONNECT request/indication/confirm.
- d) transfer of data using a layer 2 unacknowledged service:
  - TL-UNITDATA request/indication.
- e) receive report information on the progress of issued request primitives and unrecoverable transmission errors detected in the data link:
  - TL-REPORT indication.
- f) cancellation of issued request primitives:
  - TL-CANCEL request.
- g) release or loss of radio resources:
  - TL-RELEASE request;
  - TL-RELEASE indication.

On the TLB-SAP the following services and primitives should be available, see clause 20 for service definitions:

- a) reception of layer 3 information in the synchronization broadcast and system information broadcast. The broadcast shall be recognised by layer 2 and forwarded to layer 3 as SDU elements inside primitives:
  - TL-SYNC indication;
  - TL-SYSINFO indication.

### 18.2.7 Services and primitives between the MLE and the LLME

The LLME may be used for exchanging layer-to-layer information. In the protocol stack (see figure 65) the access to the LLME is modelled in the TLC-SAP.

The following primitives should be defined for this SAP:

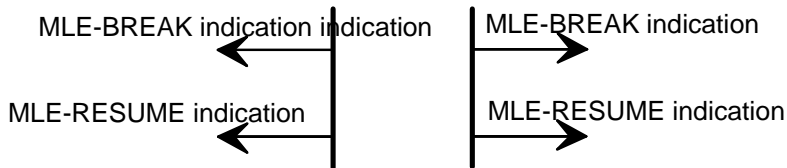
- a) control of scanning (MS side only):
  - TL-SCAN request/confirm;
  - TL-SCAN-REPORT indication.
- b) selecting cell for attachment (MS side only):
  - TL-SELECT request/indication/confirm.
- c) control of monitoring (MS side only):
  - TL-MONITOR-LIST request;
  - TL-MONITOR indication.
- d) receive quality information on the serving cell (MS side only):
  - TL-MEASUREMENT indication.
- e) receive path loss information (MS side only):
  - TL-REPORT indication.
- f) set-up and configure layer 2 according to commands from service SAP users (MS side only):
  - TL-CONFIGURE request/confirm.
- g) layer 2 configuration information to service SAP users (MS side only):
  - TL-CONFIGURE indication.

## 18.2.8 Protocol sequences

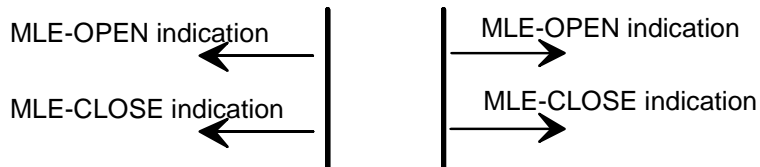
The basic protocol primitive sequences are shown in figures 66 to 68. The operation of the protocol should be modelled as a finite state automaton governed by a state variable. A transition of the automaton should be prompted by the occurrence of an event at one of three interfaces:

- a) the interface to any of the service users (MM, CMCE, Sndcp);
- b) the interface to the underlying service which is the V+D layer 2;
- c) the interface to the LLME.

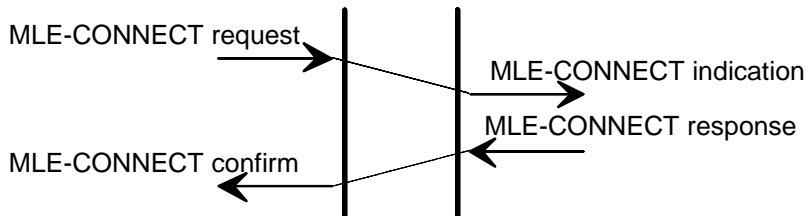
**Break and resume communication on a MLE connection**



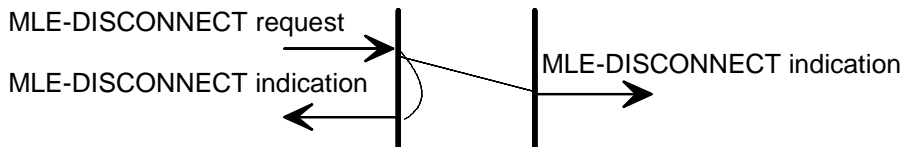
**Opening or closing of network access**



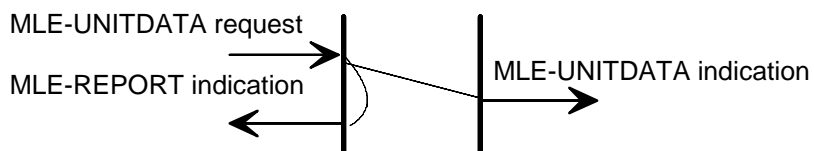
**Setup of advanced Link or Reset of advanced link**



**Disconnection of advanced link**



**Data transfer**



**Figure 66: Primitive time sequence at the LTPD-SAP**

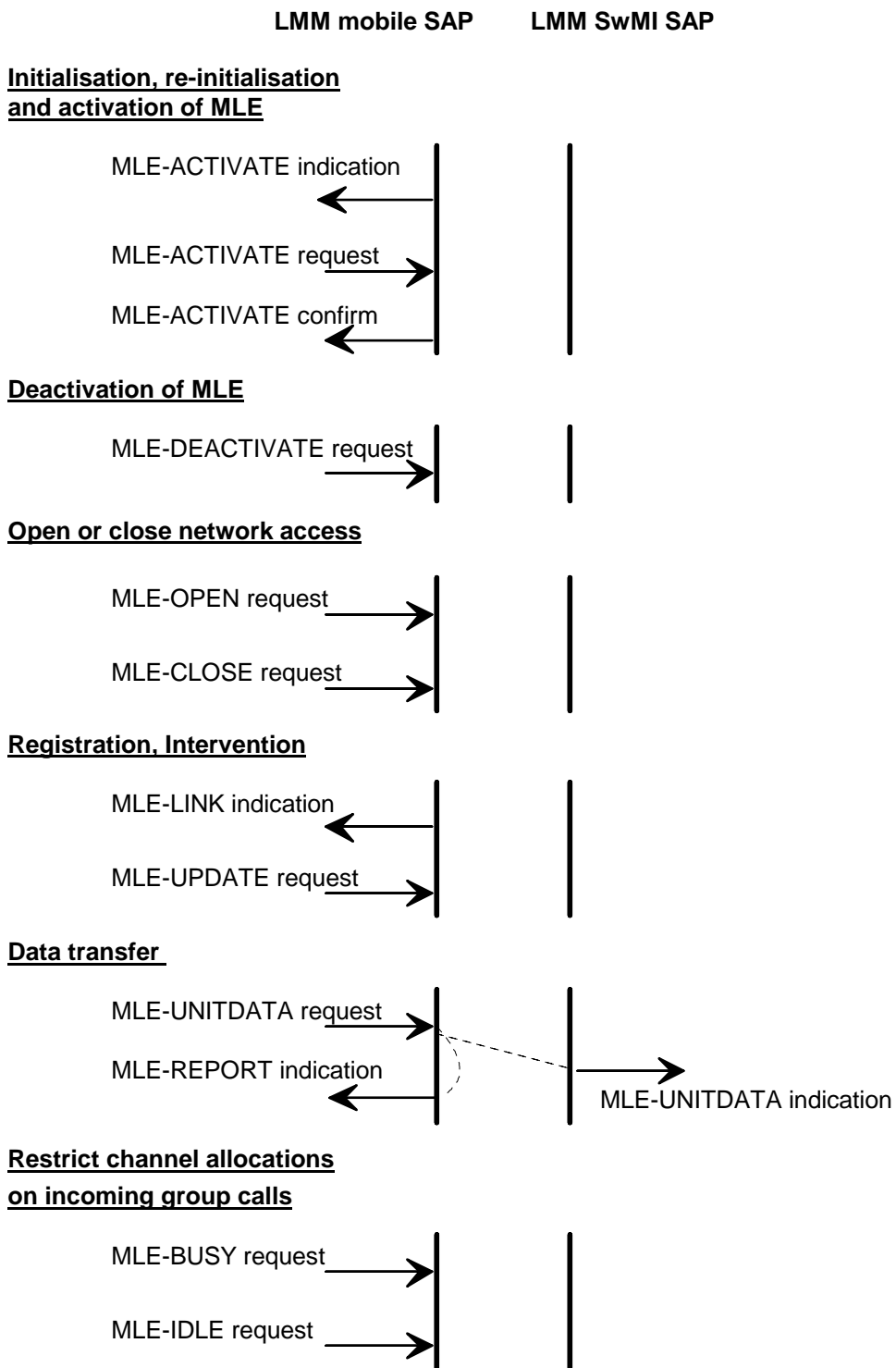
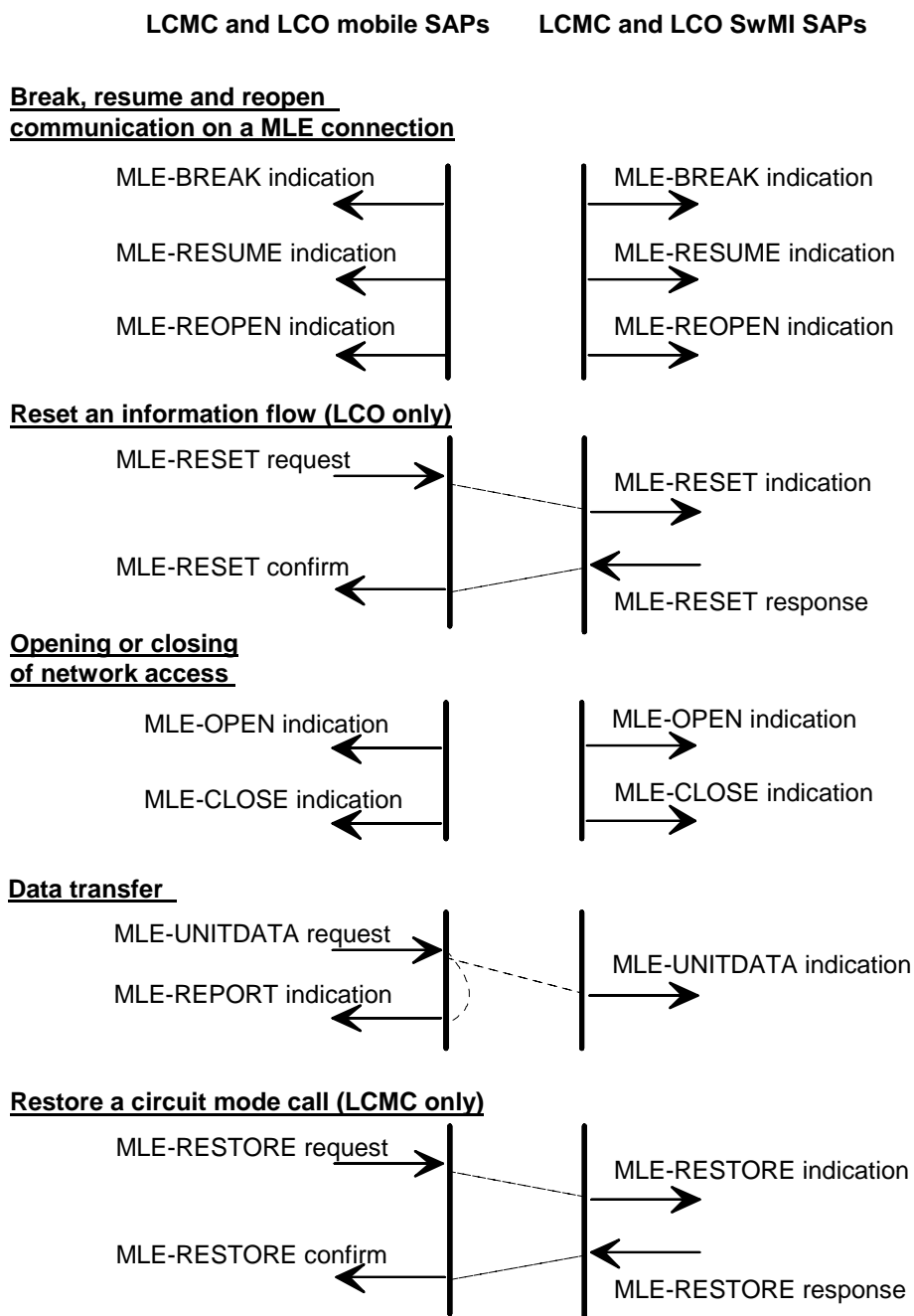


Figure 67: Primitive time sequence at the LMM-SAP



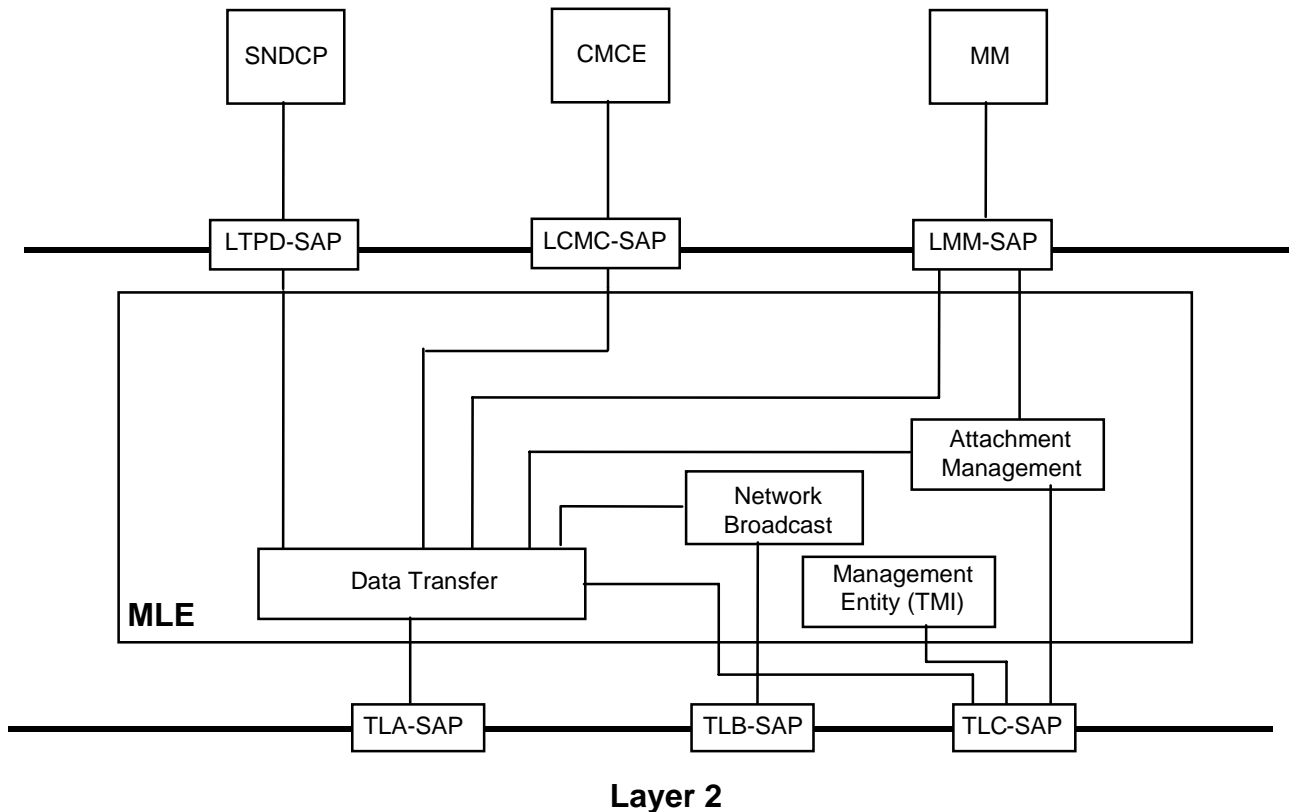
NOTE: References to LCO should be removed from figure 68; also CMCE only.

**Figure 68: Primitive time sequence at the LCMC-SAP**

## 18.3 MLE functions

### 18.3.1 Overview

The MLE functional groups are shown in figure 69.



**Figure 69: MLE functional model**

The MLE functional entities are:

- a) attachment management:
  - management of monitoring and scanning procedures;
  - surveillance of the serving cell quality;
  - management of the ranking procedure;
  - management of the cell relinquishable, improvable and usable radio criteria;
  - management of the roaming announcements and declarations;
  - informing upper entities CMCE and SNDCP of broken and restored MLE connections via the data transfer sub-entity.
- b) data transfer:
  - selection of underlying LLC service;
  - address handling (ISSI, GSSI and TMI);
  - informing the upper entities CMCE and SNDCP of enabled and disabled access to the communication resources;
  - routing and multiplexing to layer 2 service end points (including addition/removal of MLE protocol control information);

- routing and multiplexing to MLE SAPs and other MLE functional entities;
  - quality of service mapping (e.g. PDU priority, throughput, transfer service).
- c) network broadcast:
- formatting and broadcasting of the network information (SwMI);
  - reception and analysis of network information (MS/LS);
  - configuring of MAC layer 2 with synchronisation and system information broadcast.
- d) management:
- handling network management procedures, e.g. addressed to the TETRA Management Identity (TMI);
  - handling local management information from the management entity to the lower layers.

### 18.3.2 Access to the communication resources and activation of the MLE

Access to all communication resources is controlled by the MLE, according to requests received from the MM entity.

At power on, or other start-up, there is no requirement that the MLE shall have any prior knowledge of the suitability of any cell. In order that the MS can communicate, the MLE shall select a suitable cell. A suitable cell should be one in which the MS can reliably decode downlink data, which has a high probability of uplink communication and that the MS may request and obtain service.

The procedures defined in the following clauses describe methods by which the MS can select a cell.

The MLE cell selection procedure is initiated by the MM entity defining the cell selection criteria (e.g. mobile network identity) in an MLE-ACTIVATE request primitive. When a suitable cell has been found the MLE issues an MLE-ACTIVATE confirm primitive to the MM to report the cell details. Initially the radio communications link may only be used for MM data transfer until the MM issues an MLE-OPEN request primitive thereby instructing the MLE to open access to the layer 3 entities. The MM entity issues the MLE-OPEN request after completion of any MM procedures (e.g. registration). An MLE-OPEN request is received by both the attachment management and the data transfer sub-entities within the MLE. The opening of link access is reported to the CMCE and SNDTCP with an MLE-OPEN indication primitive.

NOTE: If no MM procedures are required, the MM may issue the MLE-OPEN request immediately after the MLE-ACTIVATE confirm is received.

The MLE on the MS side can take the decision to change cell from measurement processing and threshold comparisons. MM shall be informed with an MLE-LINK indication in the event that the cell reselection results in the selection of a cell in a LA that is not in the current registration area. The parameters associated with the MLE-LINK indication inform the MM of the LA, MNC and MCC of the new cell.

### 18.3.3 Deactivation of the MLE

Upon receipt of an MLE-DEACTIVATE request the MLE shall cease all functions. The MLE-DEACTIVATE should be preceded by an MLE-CLOSE request to the data transfer sub-entity.

### 18.3.4 Attachment management sub-entity

The attachment management sub-entity shall be responsible for the initial cell selection and cell reselection procedures. The initial cell selection and cell reselection procedures comprise the functions listed below. These following functions shall be activated at power on:

- management of the monitoring and scanning procedures;
- surveillance of the serving cell quality;
- management of the neighbour cell ranking procedure;
- management of the cell reselection criteria;

- management of the cell reselection announcements and declarations;
- informing upper entities CMCE and SNDCP of broken and restored MLE connections via the data transfer sub-entity.

Cell selection and reselection shall only be carried out using the individual or alias subscriber identities. Cell reselection shall not be carried out using group addresses. Any cell reselection messages received on a GSSI shall be ignored.

Where the MS is engaged in more than one call, the MS shall only apply the cell reselection procedures once and not for each call in progress. Once a cell has been re-selected the CMCE may restore the calls.

#### 18.3.4.1 Scanning of cells

Scanning is where an MS is synchronised to a cell, directly measures the received power of that cell and directly obtains the broadcast and synchronization information for that cell by decoding the BNCH and BSCH. The scanning sub-function enables the MLE to directly obtain the path loss measurements from the cells. To obtain the C1 path loss parameter from layer 2, the MS-MLE shall per cell issue a TL-SCAN request primitive to the TLC-SAP along with the parameters indicating which cell is to be scanned.

The MS-MLE shall know locally which channels the MS is capable of scanning and shall not instruct the lower layers to scan any channel that the MS-MLE knows to be outside the capabilities of the equipment. When layer 2 has completed scanning of one cell, the C1 path loss shall be part of the report parameter of the TL-SCAN confirm primitive or of the TL-SCAN-REPORT indication primitive, both given by layer 2. The C1 formula is defined in clause 23. The MS-MLE can use the list of neighbour cells in the D-NWRK-BROADCAST PDU to specify which channels to be scanned.

There are three types of scanning defined in clause 23. These are:

- foreground, where scanning is the only activity;
- background, where communications with the current serving cell are maintained in parallel with the scanning, and the scanning causes no interruption to that service;
- interrupting, where communications with the current serving cell are maintained in parallel with the scanning, but the scanning causes limited interruptions to that service.

Scanning shall have been performed within the last 60 s for a scanning measurement to be considered valid.

#### 18.3.4.2 Monitoring of neighbour cells

Monitoring is where the MS calculates the path loss parameter C2 of neighbour cells using information about the neighbour cells broadcast by the serving cell. It differs from C1 in that the serving cell provides the cell selection parameters for the neighbour cell. However, the MS is still required to directly measure the received power of the neighbour cell.

In order to be able to monitor the neighbour cells the MS-MLE shall have received a D-NWRK-BROADCAST PDU containing a list of the neighbour cells. The procedures concerning network broadcast PDUs are dealt with in clause 18.3.6. Once the network broadcast information has been received, the monitoring can be started by issuing a TL-MONITOR-LIST request primitive through the TLC-SAP. The TL-MONITOR-LIST request primitive informs layer 2 of the cells to be monitored. The parameters passed down with the TL-MONITOR-LIST shall be a list of channels. The MS-MLE shall know locally which channels the MS is capable of monitoring and shall not instruct the lower layers to monitor any channel that the MS-MLE knows to be outside the capabilities of the equipment. For each channel the lower layers return a TL-MONITOR indication containing the C2 path loss parameter. C2 is defined in clause 23.

Monitoring is a background procedure and is defined in clause 23. Monitoring shall have been performed during the last 60 s for a monitoring measurement to be considered valid.

If it is required to stop the monitoring process, the MLE shall issue a TL-MONITOR-LIST with an empty list as parameter.



### 18.3.4.3 Surveillance of the serving cell

Surveillance is the procedure whereby the MS analyses the received information on the quality of the link to the serving cell. Once the MS-MLE has chosen the serving cell, the MLE shall select that cell by issuing a TL-SELECT request primitive to the TLC-SAP. Once the cell has been selected the lower layers return a TL-SELECT confirm and periodically send TL-MEASUREMENT indication primitives containing the C1 path loss parameter for the serving cell. The C1 path loss parameter is described in clause 23. Additionally the surveillance sub-function shall be responsible for the analysis of any network broadcast information received from the serving cell via the network broadcast sub-entity.

Should the MLE receive a TL-REPORT indication from the lower layers indicating that the path to the serving cell has been lost then it shall inform the upper entities SNDCP and CMCE by issuing an MLE-BREAK indication via the data transfer sub-entity. TL-REPORT indicates that the path has been lost if the uplink or downlink have failed, or, the maximum path delay has been exceeded (uplink failure and maximum path delay exceeded can only be indicated to the MS in a MAC-RESOURCE PDU from the SwMI).

Should the MLE receive a TL-REPORT indication from the lower layers indicating "usage marker failure" then a TLC-CONFIGURE request shall be generated to move the MS to the control channel and the upper entity CMCE shall be informed via a MLE-CONFIGURE indication to signal "loss of radio resource".

If the MLE receives a TL-SELECT indication via the TLC-SAP, outside of cell reselection, indicating that the MAC has been instructed to change channels and no response is required, the surveillance function shall see note the new serving cell channel.

### 18.3.4.4 Ranking of neighbour cells

The ranking sub-function can use the path loss measurements, C1 and C2, to maintain a ranked list of neighbour cells.

The ranking algorithm shall rank the neighbour cells which have been monitored or scanned in strict order of downlink radio connection quality. The results of this algorithm can be used to determine when a cell is deemed to be radio usable, radio relinquishable or radio improvable according to clause 18.3.4.7. The use of a ranking algorithm based only on C1 or C2 is essential in order to facilitate network coverage planning.

A cell shall meet the following minimum criteria in order to be included in the ranking list of neighbour cells:

- $C1 > 0$  or  $C2 > 0$ ;

NOTE: The current registration area consists of all of the LAs in which the MS is currently registered.

- if the neighbour cell has a different MCC or MNC, the neighbour cell shall support migration (which is broadcast as part of the BS service details element).

If these criteria are not satisfied, an MS shall not include that cell in the ranking list and so shall not consider that cell for cell reselection.

If the information about the LA or MCC or MNC is not broadcast by the serving cell as part of the neighbour cell information, the MS may assume that it is free to include that cell in its ranking list provided the  $C1 > 0$  or  $C2 > 0$  criterion is met.

An MS can build a valid ranking list by obtaining the cell reselection parameters for the neighbour cells from the D-NWRK-BROADCAST PDU transmitted on the serving cell. In this case, the MS shall monitor the neighbour cells specified by D-NWRK-BROADCAST and shall calculate C2 for each one using the cell reselection parameters for the neighbour cell sent in D-NWRK-BROADCAST on the serving cell. A valid ranking list can then be derived using the C2 measurements.

An MS can also build a valid ranking list by scanning the neighbour cells to obtain the cell reselection parameters directly. In this case, the MS shall calculate C1 for each of the neighbour cells and shall derive a valid ranking list using the C1 measurements.

#### 18.3.4.4.1 Ranking of monitored cells

Ranking of monitored neighbour cells shall be based upon the received path loss parameter C2 from the layer 2 monitoring process, issued in a TL-MONITOR indication primitive.

The ranking should produce a ranked cell list which can be used as a scanning list, if the scanning function is applied. This ranked cell list may be used for making the decision of whether and when to change cell, according to clause 18.3.4.7.

#### 18.3.4.4.2 Ranking of scanned cells

Ranking of scanned neighbour cells shall be based upon the received path loss parameter C1 from the layer 2 scanning process, issued in a TL-SCAN confirm primitive or a TL-SCAN-REPORT indication primitive.

The ranking should produce a ranked cell list which may be used for making the decision of whether and when to change cell, according to clause 18.3.4.7.

#### 18.3.4.5 Criteria used during cell reselection

The following clauses define the criteria which shall be used to initiate the cell reselection procedures described in clause 18.3.4.6.

##### 18.3.4.5.1 Criterion for starting the monitoring process

The monitoring process may be permanently enabled or enabled only when some criterion is met, e.g. the serving cell ceases to support the service level required by the MS, or the serving cell quality falls below a pre-determined threshold. In the latter case it is assumed that the monitoring process would be disabled when the serving cell quality rises above the threshold plus some hysteresis factor.

The exact method for the selection of the thresholds and hysteresis values is outside the scope of the present document.

Where the monitoring process is not permanently enabled and the MS-MLE receives system broadcast information informing it that the service level required by that MS is no longer supported, e.g. that the subscriber class that the MS belongs to is no longer able to access the system, the monitoring process should be started.

Where the monitoring process is not permanently enabled, but started when a threshold value is crossed, the threshold value should be chosen to be a value greater than the threshold parameters, FAST\_RESELECT\_THRESHOLD, SLOW\_RESELECT\_THRESHOLD, to allow the MS enough time to successfully select a new cell prior to the complete loss of service from the current serving cell.

##### 18.3.4.5.2 Criterion for starting scanning

The individual criteria for starting scanning in the different selection and reselection procedures are defined in clauses 18.3.4.5 and 18.3.4.6.1 to 18.3.4.6.5.

##### 18.3.4.5.3 Criterion for radio link failure

Radio link failure occurs when the quality of the uplink or downlink radio connection falls below a certain level. A radio link failure shall be declared if any of the following events occur:

- layer 2 declares C1 path loss parameter failure ( $C1 < 0$  or AACH decoding failure as described in clause 23) for the serving cell via the TL-REPORT indication primitive (downlink failure);
- an error is reported via the TL-REPORT indication primitive indicating either that the maximum path delay has been exceeded or that an uplink failure has occurred; both of these conditions can be reported to the MS MAC from the SwMI in a MAC-RESOURCE PDU.

#### 18.3.4.5.4 Criterion for radio relinquishable cell

A serving cell becomes radio relinquishable when the quality of the downlink radio connection falls below a certain level and there is a neighbour cell which has a downlink radio connection of sufficient quality. The following conditions shall be met simultaneously in order to declare the serving cell radio relinquishable:

- the serving cell path loss parameter C1 shall for a period of 5s fall below FAST\_RESELECT\_THRESHOLD;
- the path loss parameter, C1 or C2, of at least one of the neighbour cells in the ranking list shall exceed by FAST\_RESELECT\_HYSTERESIS the path loss parameter, C1, of the current serving cell for a period of 5 s;
- no successful cell reselection shall have taken place within the previous 15 s unless MM requests a cell reselection.

The MS-MLE shall check the criterion for serving cell relinquishment as often as one neighbour cell is scanned or monitored.

#### 18.3.4.5.5 Criterion for radio improvable cell

A serving cell becomes radio improvable when the quality of a neighbour cell downlink radio connection exceeds that of the serving cell by a certain amount. The following conditions shall be met simultaneously in order to declare the serving cell radio improvable:

- the serving cell path loss parameter, C1 shall, for a period of 5 s, fall below SLOW\_RESELECT\_THRESHOLD;
- the path loss parameter, C1 or C2, of at least one of the neighbour cells in the ranking list shall exceed by SLOW\_RESELECT\_HYSTERESIS the path loss parameter, C1, of the current serving cell for a period of 5 s;
- no successful cell reselection shall have taken place within the previous 15 s unless MM requests a cell reselection.

The MS-MLE shall check the criterion for improving the serving cell as often as one neighbour cell is scanned or monitored.

#### 18.3.4.5.6 Criterion for radio usable cell

A neighbour cell becomes radio usable when it has a downlink radio connection of sufficient quality. The following condition shall be met in order to declare a neighbour cell radio usable:

- the neighbour cell shall for a period of 5s have a path loss parameter, C1 or C2, which is greater than (FAST\_RESELECT\_THRESHOLD + FAST\_RESELECT\_HYSTERESIS);
- no successful cell reselection shall have taken place within the previous 15 s unless MM requests a cell reselection.

The MS-MLE shall check the criterion for a neighbour cell being usable each time the neighbour cell is scanned or monitored.

#### 18.3.4.5.7 Criteria for initiating the cell reselection procedures

Cell reselection shall be initiated by the MLE if the serving cell is declared radio improvable (as defined in clause 18.3.4.5.5) and the service criteria as defined below are the same on both the serving cell and the radio improvable neighbour cell. If the service provided by the neighbour cell is lower than that provided by the serving cell, the cell reselection may be postponed until the serving cell is declared radio relinquishable (as defined in clause 18.3.4.5.4). If the service provided by the neighbour cell is higher than that provided by the serving cell, then the cell reselection may be performed as soon as the neighbour cell is declared radio usable (as defined in clause 18.3.4.5.6).

If cell reselection is initiated by the user application, the MLE shall receive a MLE-LINK request from MM containing the MCC and MNC and possibly also the LA of the desired cell. If, within the LA(s) specified in the MLE-LINK request, the MLE is able to find a cell fulfilling the criterion where service provided by the neighbour cell is same or higher than provided by the serving cell, then the cell reselection may be performed as soon as the neighbour cell is declared radio usable (as defined in clause 18.3.4.5.6). Upon selection of the new cell, the MLE shall send a MLE-LINK indication to MM. If the MLE is unable to find a suitable cell, it shall respond to MM with a MLE-ACTIVATE indication.

The following service criteria may be used to compare the service provided by a serving cell and a neighbour cell:

- support for subscriber class (broadcast as part of D-MLE-SYSINFO PDU);
- support for system-wide services (broadcast as part of the BS service details element);
- priority cell indication (broadcast as part of the BS service details element);
- support for TETRA standard speech (broadcast as part of the BS service details element);
- support for TETRA circuit mode data (broadcast as part of the BS service details element);
- support for TETRA packet data services (broadcast as part of the BS service details element);
- support for air interface encryption (broadcast as part of the BS service details element);
- cell service level (broadcast as part of D-MLE-SYNC PDU);
- whether or not the current serving cell or LA is preferred over the neighbour cell (which may be stored in the MS at subscription);
- whether or not a circuit mode call or C-plane signalling transfer is in progress.

The BS service details element and the cell service level are broadcast in the MLE-SYSINFO PDU (transmitted on BNCH) and MLE-SYNC PDU (transmitted on BSCH) respectively for the serving cell, and in the D-NWRK-BROADCAST for the neighbour cells. BSCH and BNCH shall be transmitted on the serving cell and D-NWRK-BROADCAST may be transmitted on the serving cell.

Using the above criteria, an MS may decide whether or not a neighbour cell can be considered to offer better service than the current serving cell. The following conditions shall cause the MS to rate a neighbour cell to have better service than the current serving cell:

- the MS subscriber class is supported on the neighbour cell but not on the serving cell;
- the neighbour cell is a priority cell and the serving cell is not a priority cell;
- the neighbour cell supports a service (i.e. TETRA standard speech, circuit mode data or TETRA packet data services) which is not supported by the serving cell and the MS requires that service to be available;
- the neighbour cell supports air interface encryption which is not supported by the serving cell and the MS requires that air interface encryption is available;
- the neighbour cell supports system-wide services which are not supported by the serving cell;
- the cell service level indicates that the neighbour cell is more lightly loaded than the serving cell;
- the neighbour cell is a preferred cell (or "home cell") or belongs to a preferred LA. In these cases the MS may choose to initiate cell reselection as soon as the neighbour cell becomes radio usable as defined in clause 18.3.4.5.6. If there is more than one neighbour cell which is radio usable, the MS should choose the one which gives the highest ranking in the ranking list and which best satisfies the service requirements for the MS.

The following conditions shall cause the MS to rate a neighbour cell to have lower service than the current serving cell:

- the MS subscriber class is not supported on the neighbour cell but is supported on the serving cell;
- the serving cell is a priority cell and the neighbour cell is not a priority cell;
- the serving cell supports a service (i.e. TETRA standard speech, circuit mode data or TETRA packet data services) which is not supported by the neighbour cell and the MS requires that service to be available;
- the serving cell supports air interface encryption which is not supported by the neighbour cell and the MS requires that air interface encryption is available;
- the serving cell supports system-wide services which are not supported by the neighbour cell;
- the cell service level indicates that the serving cell is loaded more lightly than the neighbour cell;
- the serving cell is a preferred cell (or "home cell") or belongs to a preferred LA.

In these cases the MS may postpone cell reselection until the serving cell becomes radio relinquishable as defined in clause 18.3.4.5.4. If there is more than one neighbour cell which causes the serving cell to be radio relinquishable, the MS should choose the highest ranked cell in the ranking list which satisfies the service requirements for the MS.

If the neighbour cell is deemed to offer neither better service or lower service over the serving cell, the service shall be deemed to equal and the MS shall initiate the cell reselection procedures as soon as a neighbour cell becomes radio improvable over the current serving cell as defined in clause 18.3.4.5.5. A neighbour cell shall be deemed to be equal with respect to the above service criteria if the information is not available for either the serving or neighbour cell e.g. the cell service level may not be included in the D-NWRK-BROADCAST PDU causing the service to be deemed equal with respect to cell service level.

If a neighbour cell is deemed to provide equal or better service than the current serving cell, the cell reselection should be postponed if there is a circuit mode call or ongoing signalling currently in progress. In this case, the cell reselection should be postponed until the serving cell becomes radio relinquishable, even if there are neighbour cells which meet the radio improvable or radio usable criteria.

If radio link failure occurs (which can occur when there are no neighbour cells of sufficient radio connection quality to make the serving cell relinquishable), the MS may re-select any neighbour cell in the ranking list whose path loss parameter, C1 or C2, is greater than zero. If there are multiple cells in the ranking list which meet this radio criterion, the MS should choose the highest ranked cell which satisfies the service requirement for the MS. If there are no cells which meet this minimum radio criterion, the initial cell selection procedure shall be invoked.

#### 18.3.4.6 Initial cell selection

The MS shall implement the initial cell selection procedure when the MS-MLE receives an MLE-ACTIVATE request from MM e.g. when not attached to a cell, at power on, or after a previous deactivation has taken place. The exact detailed implementation of the procedure and any associated algorithms is outside the scope of the present document. The MS shall be required to fulfil certain conditions as stated below. The procedure shall be referred to as the "initial cell selection" procedure. This does not imply that the procedure shall necessarily be different from any procedures applied for cell reselection.

The initial cell selection procedure shall ensure that the MS selects a cell in which it can reliably decode downlink data and which has a high probability of uplink communication. The minimum conditions that shall have to be met are that  $C1 > 0$ . Access to the network shall be conditional on the successful selection of a cell.

The procedure shall be initiated by the receipt of the MLE-ACTIVATE request primitive from the MM entity. This primitive has parameters which include the MCC and the MNC of the particular network which the MS should select. The MS-MLE shall then use this information, and initiate the foreground scanning procedure and thus obtain the path loss parameter C1 and the network broadcast information for each cell. This information can be used to produce a list of preferred cells. These cells shall then be ranked by the MS-MLE. The ranking algorithm is outside the scope of the present document.

In the event that there are no suitable cells available when all cells in the list have been scanned, the MLE shall inform the MM entity with an MLE-ACTIVATE indication that no suitable cell has been found. The MLE shall continue the scanning of cells until a suitable cell is found, or until the MS is powered down. The exact procedures, algorithms and parameters applied for the continued scanning of cells are outside the scope of the present document.

The MS shall select a cell which has  $C1 > 0$ . The MS should choose the cell which has the highest ranking according to the initial cell selection ranking procedure.

NOTE: The initial cell selection ranking procedure is not defined by the present document.

The cell shall be selected by issuing a TL-SELECT request primitive to the TLC-SAP. The parameters of the TL-SELECT request inform the lower layers of the channel and the parameters, MS\_TXPWR\_MAX\_CELL and RXLEV\_ACCESS\_MIN for the cell. Once the cell has been selected the lower layers return a TL-SELECT confirm. The MLE shall issue an MLE-ACTIVATE confirm to the MM. If registration is required in the cell, the MM shall then register. If the registration is successful or if no registration is required, the MLE may receive an MLE-UPDATE request from MM supplying information regarding updated search areas for further monitoring.

If the registration is to a cell which has its "System wide services" parameter set to "System wide services temporarily not supported" and the registration is accepted with a Location update accept type value of "Temporary registration" then the MS shall consider itself to be temporarily registered.

If the MS has received a "Temporary registration" acknowledgement and then initiates a cell reselection, it shall register to the new cell even if the cell belongs to the Registered Area of the MS.

In the event that the initial cell selection is unsuccessful as a result of registration or authentication failure, MM shall instruct the MLE attachment management sub-entity, using an MLE-UPDATE request, to suspend the ranking of that cell. This shall result in the selection of a different cell by the MLE, unless all opportunities have been used, in which case MM shall close the MLE service.

Upon receipt of the MLE-OPEN request, the MLE shall send MLE-OPEN indication to the higher layer 3 entities, CMCE and SNDPCP and shall initiate the serving cell surveillance procedures for the new cell as defined in clause 18.3.4.3 and may also initiate monitoring or background/interrupting scanning of neighbour cells.

#### 18.3.4.7 Cell reselection

This clause defines the overall process of the cell reselection procedure.

The cell reselection procedure shall ensure that the MS selects a cell in which it can reliably decode downlink data and in which it has a high probability of uplink communication according to the criteria in clause 18.3.4.5.7. The minimum conditions which shall have to be met are that  $C1 > 0$  and, in the case of an MS in a circuit mode call that the maximum path delay is not exceeded.

NOTE: The SwMI informs the MS that maximum path delay is exceeded in a MAC-RESOURCE PDU.

If the cell reselection procedure is unsuccessful, such that the MLE is left with no usable radio channels, the MS-MLE shall indicate this to the MM using an MLE-ACTIVATE indication. MM may give further instructions, e.g. new LAs, or, if all opportunities have been used, MM shall close the MLE services (see clause 16). When the MM eventually opens up the services again, MS-MLE shall be activated and the initial cell selection procedures as specified in clause 18.3.4.5 shall apply.

Cell reselection can be performed by the MS-MLE when a MS is attached to a cell in idle or traffic mode. The procedure can handle the following categories as listed below:

- undeclared;
- unannounced;
- announced type 3;
- announced type 2;
- announced type 1.

Where an MS is idle i.e. not involved in any voice or data calls and where there is no advanced link established, then the MS MLE shall perform undeclared cell reselection. Where a MS has an advanced link established, and it is not involved in any voice or circuit mode data calls, then the MS MLE shall perform undeclared cell reselection. Where a MS is involved in a voice or circuit mode data call, then cell reselection shall be performed based on the criteria set out below and in figure 70. In the cases, where there is an advanced link established and where the MS does not support advanced link roaming, it is recommended that the MS MLE disconnects this advanced link prior to performing cell reselection.

Undeclared cell reselection is performed by the MLE when there are no calls in progress. The MS may attempt to recover SNDCP and/or advanced link connections on the new cell.

Unannounced cell reselection is used when the MS is unable to or, in the case of listening to group calls, has no need to send the announcement signalling to the serving cell prior to performing the cell reselection. The MS may attempt to recover the CMCE and SNDCP connections on the new cell.

Announced cell reselection is used when the MS informs the serving cell prior to the cell change, and attempts to restore the call(s) upon arrival at the new serving cell. This maximises the probability of restoring the CMCE and SNDCP connections on the new cell. Announced cell reselection is divided into three categories to reflect different levels of SwMI and MS functionality.

Type 3 reselection is provided for MSs which are unable to perform background scanning of a selected neighbour cell, and which must therefore break the call(s) for a period and perform foreground scanning in order to acquire broadcast and synchronization information for the new cell. Upon selecting the new cell, call restoration signalling can be used to restore the call(s).

Type 2 reselection requires that the MS is able to perform background scanning of a selected neighbour cell, and is therefore in a position to immediately switch to the new cell. In type 2 the SwMI does not direct the MS to a channel in the new cell. The MS selects the MCCH on the new cell and performs call restoration signalling and may then be allocated a traffic channel upon successful completion of this signalling.

Type 1 reselection requires that the MS is able to perform background scanning, and that the SwMI is able to direct the MS from the traffic channel on the original cell directly to the MCCH or to a traffic channel on the new cell. If the SwMI directs the MS to MCCH, the SwMI may later allocate a traffic channel; no call restoration signalling is required from the MS.

Unannounced and the three types of announced cell reselection shall apply to an MS engaged in a circuit mode call or where an advanced link is established for use by the SNDCP entity.

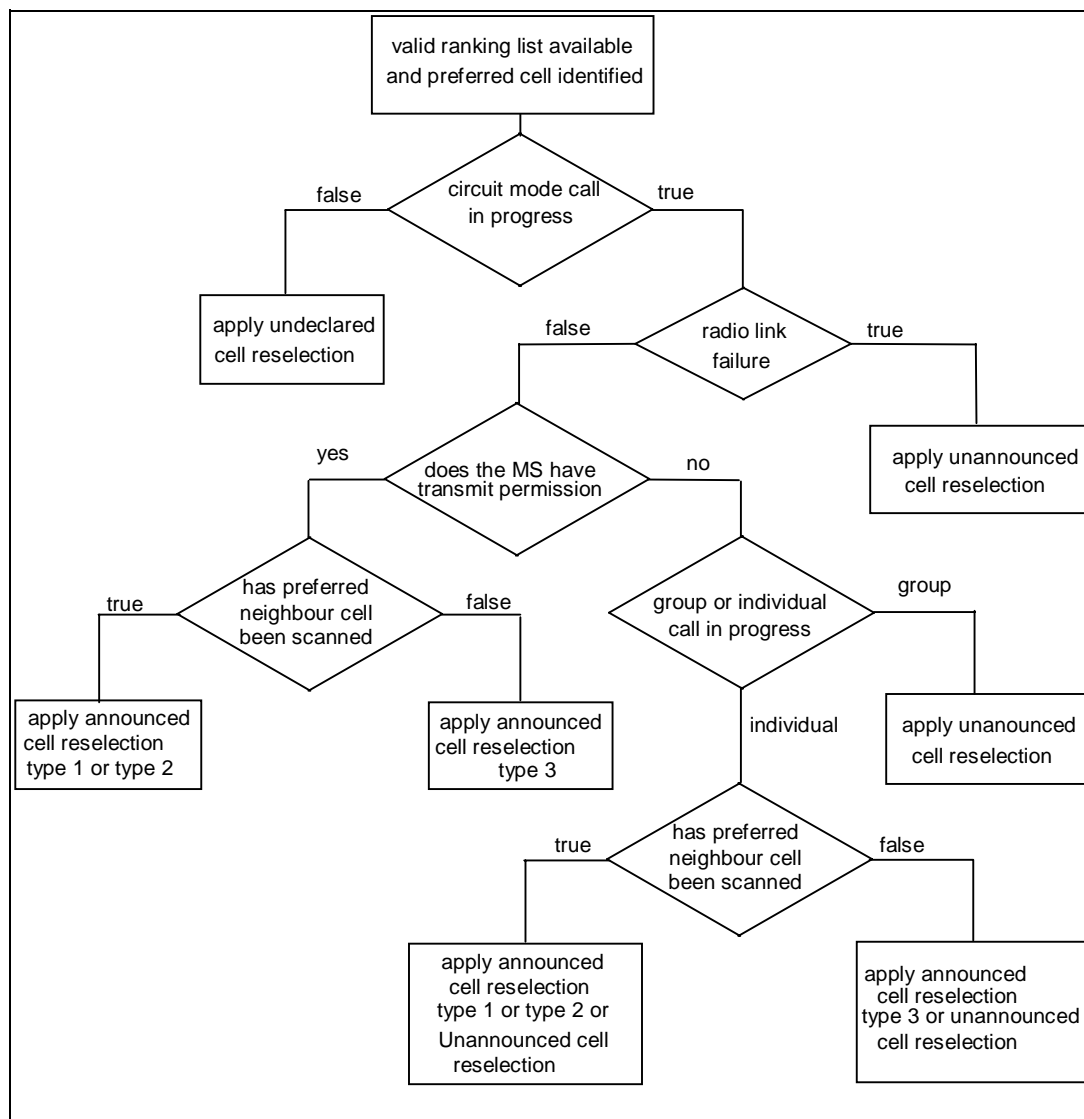
All MS-MLE shall support undeclared, unannounced and announced type 3 cell reselection. An MS-MLE may also support announced type 2 and announced type 1 cell reselection. It is not necessary for the SwMI to know which type of cell reselection procedures the MS can support in order for these procedures to work. The MS shall determine which types of reselection are supported by the SwMI from the neighbour cell information element transmitted in the D-NWRK-BROADCAST PDU.

If the SwMI does not support neighbour cell information in the D-NWRK-BROADCAST transmission (see clause 18.3.6), the SwMI shall only be able to support undeclared, unannounced and announced type 3 cell reselection.

If the SwMI supports neighbour cell information in the D-NWRK-BROADCAST transmission, the MS shall attempt announced type 1 and type 2 cell reselection only to a neighbour cell contained in the D-NWRK-BROADCAST PDU.

## 18.3.4.7.1 Determination of which type of reselection to apply

The decision tree for deciding which cell reselection type to use is shown in figure 70.



NOTE: If there is no circuit mode in progress, SNDCP applies undeclared cell reselection.

**Figure 70: Decision tree to choose reselection type**

The MS shall normally perform cell reselection as a result of building a ranking list from monitoring or scanning of neighbour cells. From the neighbour cell measurements, one of the cell reselection criteria defined in clause 18.3.4.7 may be met causing cell reselection to be initiated. The cell chosen as the one to which the MS will attempt to select is known as the preferred neighbour cell.

In the case where the MS has knowledge of the neighbour cells (e.g. from the D-NWRK-BROADCAST PDU or from scanning or pre-programmed at subscription), but has not yet built a valid ranking list, radio link failure may occur or the maximum path delay may be exceeded. If this happens, the MS shall apply undeclared cell reselection if not currently participating in a circuit mode. If the MS is participating in a call or data transfer, the MS shall apply unannounced cell reselection.

If the MS has no knowledge of neighbour cells, the MS should apply cell reselection according to initial cell selection procedures, and then on the new cell the MS shall apply undeclared cell reselection procedure if not currently participating in a circuit mode call. If the MS is participating in a call, the MS may apply either unannounced or undeclared cell reselection procedure.



The MS shall initiate cell reselection subject to the criteria specified in clause 18.3.4.7. It shall determine which type of reselection is to be applied from figure 70. The type of reselection to be employed shall depend on the following criteria:

- whether or not a circuit mode call transfer is in progress;
- whether or not an advanced link is established for use by SNDCP;
- whether the call is an individual or group call;
- whether or not transmit permission has been granted;
- whether or not the MS has scanned the preferred neighbour cell.

The cell reselection procedure shall be initiated after the MS has built a valid ranking list and one of the cell reselection criteria as defined in clause 18.3.4.7 has resulted in selection of a preferred neighbour cell. An MS shall scan the preferred neighbour cell before it can select that cell. If the MS can perform background scanning of a preferred neighbour cell, then it may attempt to use announced type 1 or 2 cell reselection. Otherwise, the MS shall use unannounced or announced type 3 cell reselection.

If the MS has performed background scanning of a preferred neighbour cell, then it is recommended that the MS uses announced type 1 or 2 cell reselection. Otherwise, the MS shall use unannounced or announced type 3 cell reselection.

The MS may choose to use type 1 or type 2 cell reselection according to the capabilities of the SwMI. If the SwMI does not support forward registration (as indicated in the serving cell information element broadcast as part of the D-NWRK-BROADCAST PDU) and registration is required on the new cell, the MS shall choose the announced type 2 cell reselection.

Where the decision tree indicates that the MS should choose type 1 or type 2 cell reselection and if the SwMI supports forward registration, the MS can choose either of them. If the MS attempts type 1 cell reselection, the SwMI may respond with a type 2 cell reselection procedure causing the MS to select the MCCH and perform call restoration on the neighbour cell instead of the SwMI directing the MS to the MCCH or to a traffic channel on the new cell, the MS therefore not being required to perform call restoration on the new cell.

#### 18.3.4.7.2 Undeclared cell reselection

Undeclared cell reselection shall be initiated by an MS if it is not currently involved in any circuit mode calls and one of the cell reselection criteria described in clause 18.3.4.7 is met causing a preferred neighbour cell to be selected. If cell reselection is initiated as a result of a radio relinquishable, radio improvable or radio usable condition, a preferred neighbour cell shall have been identified by the MS-MLE. This preferred neighbour cell may or may not have been scanned by the MS-MLE before cell reselection is initiated. If cell reselection is initiated as a result of radio link failure, a preferred neighbour cell may not yet have been identified.

Upon initiation of the undeclared cell reselection procedure, the MS-MLE shall perform the following actions:

- a) issue MLE-BREAK indication, informing the higher layer 3 entities, SNDCP and CMCE, that the radio link to the current serving cell is unavailable for C-plane signalling;
- b) if no preferred neighbour cell has been selected, initiate foreground scanning of neighbour cells to select a preferred neighbour cell;
- c) if a preferred neighbour cell has been selected and background scanning of the preferred cell has not been performed, initiate foreground scanning of the preferred cell to confirm the selection;
- d) issue TL-SELECT request via the TLC-SAP to cause the MAC to switch to the main carrier of the new cell; the MAC responds with TL-SELECT confirm once the new cell has been selected.

Registration shall be required if the following conditions are satisfied:

- the preferred neighbour cell does not belong to the same network as the current cell; or
- the preferred neighbour cell is in a LA which is outside the current registered area of the MS; and
- registration is required in the new cell as indicated in the BS service details element which is either received as part of the neighbour cell information in the D-NWRK-BROADCAST PDU or on the new cell in the D-MLE-SYSINFO PDU;
- MS has received a "temporary registration" on the serving cell i.e. MS is temporarily registered, it shall register to the new cell even if the cell belongs to the registered area of the MS;
- the preferred neighbour cell has its "System wide services" parameter set to "System wide services temporarily not supported" - the MS shall register to the new cell even if the cell belongs to the registered area of the MS.

If registration is required, MLE shall issue MLE-LINK indication to MM.MM shall indicate successful registration by issuing MLE-UPDATE request to MLE confirming the cell. If registration was successful or if no registration was necessary, MLE shall send MLE-REOPEN indication to the upper layer 3 entity CMCE, to indicate that the radio link is once again available for C-plane signalling. MLE shall send MLE-RESUME indication to SNDTCP, to indicate that the radio link is once again available for C-plane signalling.

If the registration is to a cell which has its "System wide services" parameter set to "System wide services temporarily not supported" and the registration is accepted with a Location update accept type value of "Temporary registration" then the MS shall consider itself to be temporarily registered.

If the registration result indicates "Cell Rejected", the MLE shall:

- if the rejected cell is the only cell available, the MLE shall re-apply cell reselection procedures; or
- if the rejected cell is not the only cell available, the MLE shall remove the rejected cell from the ranking list may attempt to select another cell from the ranking list and re-apply cell reselection procedures. The rejected cell may only be included again in the ranking list as a result of an attempted reselection to another cell or until the MS is next powered on.

If the registration result indicates "LA Rejected", the MLE shall remove all cells with the LA in this MNC/MCC from the ranking list. The MLE may attempt to select another cell from the ranking list and re-apply cell reselection procedures. In all registration cases, cells with the rejected LA may be included in the ranking list again when one of the following conditions apply:

- after successful location update to a cell in a different LA;
- until the MS is next powered on.

NOTE: Cells with the rejected LA may also be included in the ranking list again after a suitable time or when the LA becomes available through the use of a "denied LA list". An MS may manage such a list, for example, to avoid oscillating between two rejected cells.

If the registration result indicates "System Rejected", the MLE shall remove all cells with the rejected MNC/MCC from the ranking list. The MLE may attempt to select another cell from the ranking list and re-apply cell reselection procedures. In all registration cases, cells with the rejected MNC/MCC may be included in the ranking list again after an attempted reselection to a cell with a different MNC/MCC or until the MS is next powered on.

SNDTCP may re-establish packet data communications as described in clause 28.3.4.2, by re-establishing an advanced link on the new cell. Where the MS supports advanced link roaming, SNDTCP may attempt to reconnect the advanced link as described in clause 28.3.4.4.

### 18.3.4.7.3 Unannounced cell reselection

Unannounced cell reselection shall be initiated by an MS if one of the cell reselection criteria described in clause 18.3.4.7 is met and unannounced cell reselection is chosen according to the decision tree in figure 70. If cell reselection is initiated as a result of a radio relinquishable, radio improvable or radio usable condition, a preferred neighbour cell shall have been identified by the MS-MLE. This preferred neighbour cell may or may not have been scanned by the MS-MLE before cell reselection is initiated. If cell reselection is initiated as a result of radio link failure, a preferred neighbour cell may not yet have been identified.

Upon initiation of the unannounced cell reselection procedure, the MS-MLE shall perform the following actions:

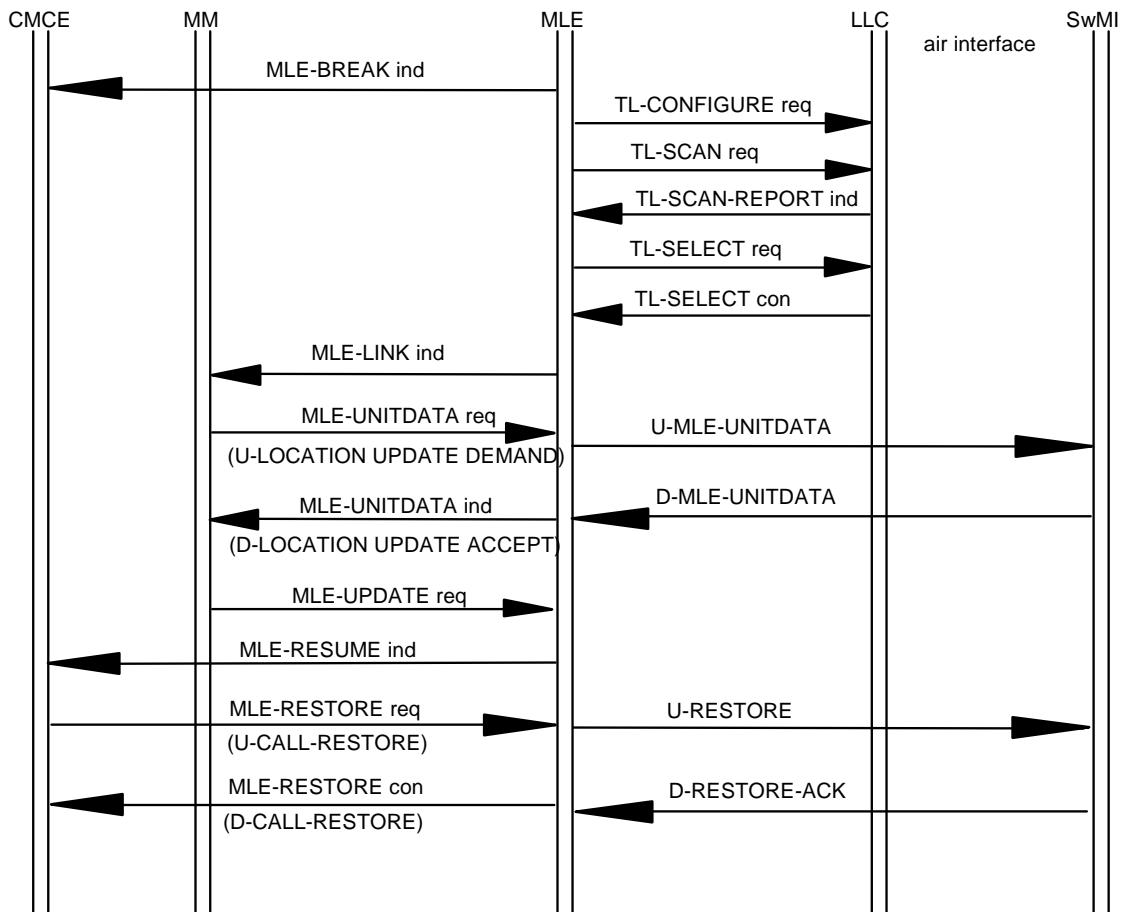
- a) issue MLE-BREAK indication, informing the higher layer 3 entities, SNDTCP and CMCE, that the radio link to the current serving cell is unavailable for C-plane signalling;
- b) where the MS does not support advanced link roaming, locally disconnect any advanced links by issuing TL-RELEASE request via the TLA-SAP to layer 2;
- c) if no preferred neighbour cell has been selected, initiate foreground scanning of neighbour cells to select a preferred neighbour cell;
- d) if a preferred neighbour cell has been selected and background scanning of the preferred cell has not been performed, initiate foreground scanning of the preferred cell to confirm the selection;
- e) issue TL-SELECT request via the TLC-SAP to cause the MAC to switch to the main carrier of the new cell; the MAC responds with TL-SELECT confirm once the new cell has been selected.

Registration shall be required if the following conditions are satisfied:

- the preferred neighbour cell does not belong to the same network as the current cell; or
- the preferred neighbour cell is in a LA which is outside the current registered area of the MS; and
- registration is required in the new cell as indicated in the BS service details element which is either received as part of the neighbour cell information in the D-NWRK-BROADCAST PDU or on the new cell in the D-MLE-SYSINFO PDU;
- MS has received a "temporary registration" on the serving cell i.e. MS is temporarily registered, it shall register to the new cell even if the cell belongs to the registered area of the MS;
- the preferred neighbour cell has its "System wide services" parameter set to "System wide services temporarily not supported" - the MS shall register to the new cell even if the cell belongs to the registered area of the MS.

If registration is required, MLE shall issue MLE-LINK indication to MM.

If the registration is to a cell which has its "System wide services" parameter set to "System wide services temporarily not supported" and the registration is accepted with a Location update accept type value of "Temporary registration" then the MS shall consider itself to be temporarily registered.



**Figure 71: Unannounced cell reselection procedure**

If the registration result indicates "Cell Rejected", the MLE shall:

- if the rejected cell is the only cell available, the MLE shall re-apply cell reselection procedures; or
- if the rejected cell is not the only cell available, the MLE shall remove the rejected cell from the ranking list may attempt to select another cell from the ranking list and re-apply cell reselection procedures. The rejected cell may only be included again in the ranking list as a result of an attempted reselection to another cell or until the MS is next powered on.

If the registration result indicates "LA Rejected", the MLE shall remove all cells with the LA in this MNC/MCC from the ranking list. The MLE may attempt to select another cell from the ranking list and re-apply cell reselection procedures. In all registration cases, cells with the rejected LA may be included in the ranking list again when one of the following conditions apply:

- after a successful location update to a cell in a different LA;
- until the MS is next powered on.

NOTE 1: Cells with the rejected LA may also be included in the ranking list again after a suitable time or when the LA becomes available through the use of a "denied LA list". An MS may manage such a list, for example, to avoid oscillating between two rejected cells.

If the registration result indicates "System Rejected", the MLE shall remove all cells with the rejected MNC/MCC from the ranking list. The MLE may attempt to select another cell from the ranking list and re-apply cell reselection procedures. In all registration cases, cells with the rejected MNC/MCC may be included in the ranking list again after an attempted reselection to a cell with a different MNC/MCC or until the MS is next powered on.

MM shall indicate successful registration by issuing MLE-UPDATE request to MLE confirming the cell. If registration was successful or if no registration was necessary, MLE shall send MLE-RESUME indication to the upper layer 3 entities, CMCE and SNDCP, to indicate that the radio link is once again available for C-plane signalling.

CMCE may attempt to restore any circuit mode calls which were in existence before the cell change. CMCE shall restore a call by responding to the MLE-RESUME indication primitive with MLE-RESTORE request, containing a CMCE call restoration PDU. MLE shall send a U-RESTORE PDU, containing the CMCE call restoration SDU using the LLC acknowledged service. The U-RESTORE PDU shall contain each of the following elements only if the value on the new cell is different from that on the old cell:

- MCC;
- MNC;
- LA.

NOTE 2: The MCC, MNC and LA refer to the old cell.

If call restoration is successful, MLE shall receive a D-RESTORE ACK PDU from the SwMI which shall contain the CMCE downlink call restoration signalling PDU. Upon receipt of the D-RESTORE ACK PDU indicating successful cell reselection, MLE shall issue MLE-RESTORE confirm to the CMCE. The MLE-RESTORE confirm primitive which is passed to CMCE shall contain the CMCE restoration signalling PDU.

NOTE 3: CMCE may attempt to restore multiple circuit mode calls using the above restoration procedure for each call. Calls shall be restored one at a time with a call restoration signalling sequence for each one.

NOTE 4: A successful call restoration, indicated by D-CALL RESTORE/D-RESTORE ACK should include a channel allocation in the MAC header if the restored call currently has a traffic channel allocation.

If the D-RESTORE FAIL PDU is received instead, it shall indicate that call restoration was unsuccessful. The "Fail cause" element of the D-RESTORE FAIL PDU shall contain value "Restoration cannot be done on cell". MLE shall then issue MLE-REOPEN indication to the CMCE to indicate that the radio path is restored, but that the calls have not been restored. The D-RESTORE FAIL PDU shall not carry an SDU for any of the higher layer 3 entities.

SNDCP may re-establish packet data communications as described in clause 28.3.4.2, by re-establishing an advanced link on the new cell. Where the MS supports advanced link roaming, SNDCP may attempt to reconnect the advanced link as described in clause 28.3.4.4.

#### 18.3.4.7.4 Announced cell reselection - type 3

Announced type 3 cell reselection shall be initiated by an MS if one of the cell reselection criteria described in clause 18.3.4.7 is met and announced type 3 cell reselection is chosen according to the decision tree in figure 70. If cell reselection is initiated as a result of a radio relinquishable, radio improvable or radio usable condition, a preferred neighbour cell shall have been identified by the MS-MLE. This preferred neighbour cell may or may not have been scanned by the MS-MLE before cell reselection is initiated. If cell reselection is initiated as a result of radio link failure, announced type 3 cell reselection shall not be attempted by the MS.

Upon initiation of the announced type 3 cell reselection procedure, the MS-MLE shall send a U-PREPARE PDU to the SwMI. The U-PREPARE PDU shall not contain the cell identifier element and the PDU shall not carry an SDU.

NOTE 1: The fact that the cell identifier element is not present in the PDU informs the SwMI that a preferred neighbour cell has not yet been selected and that the MS-MLE is attempting announced type 3 cell reselection.

MLE shall send the U-PREPARE PDU by issuing TL-DATA request to layer 2 with the primitive parameters set as follows:

- PDU priority shall be set to 6;
- stealing permission shall be set to "steal immediately";
- the stealing repeats flag shall not be set.

NOTE 2: By transmitting the U-PREPARE PDU, the MS informs the SwMI that it is about to change cell. The SwMI should also recognise the effect of the cell change on any circuit mode calls that the MS is currently involved in.

MLE shall start timer, T370, and shall await the response from the SwMI. The SwMI shall respond with D-NEW CELL with the channel command valid element set either to "Change channel immediately" or "No channel change". If set to "Change channel immediately", MLE shall reset timer T370 and initiate the cell change procedure described below. If set to "No channel change", MLE shall restart timer, T370, and wait for another D-NEW-CELL PDU from the SwMI. If, while waiting for D-NEW CELL from the SwMI, radio link failure occurs, the MS shall abandon the announcement signalling and initiate the cell change procedure immediately.

NOTE 3: The value "Follow MAC Channel Change" cannot be used for type 3 reselection, it can be used only for type 1 reselection.

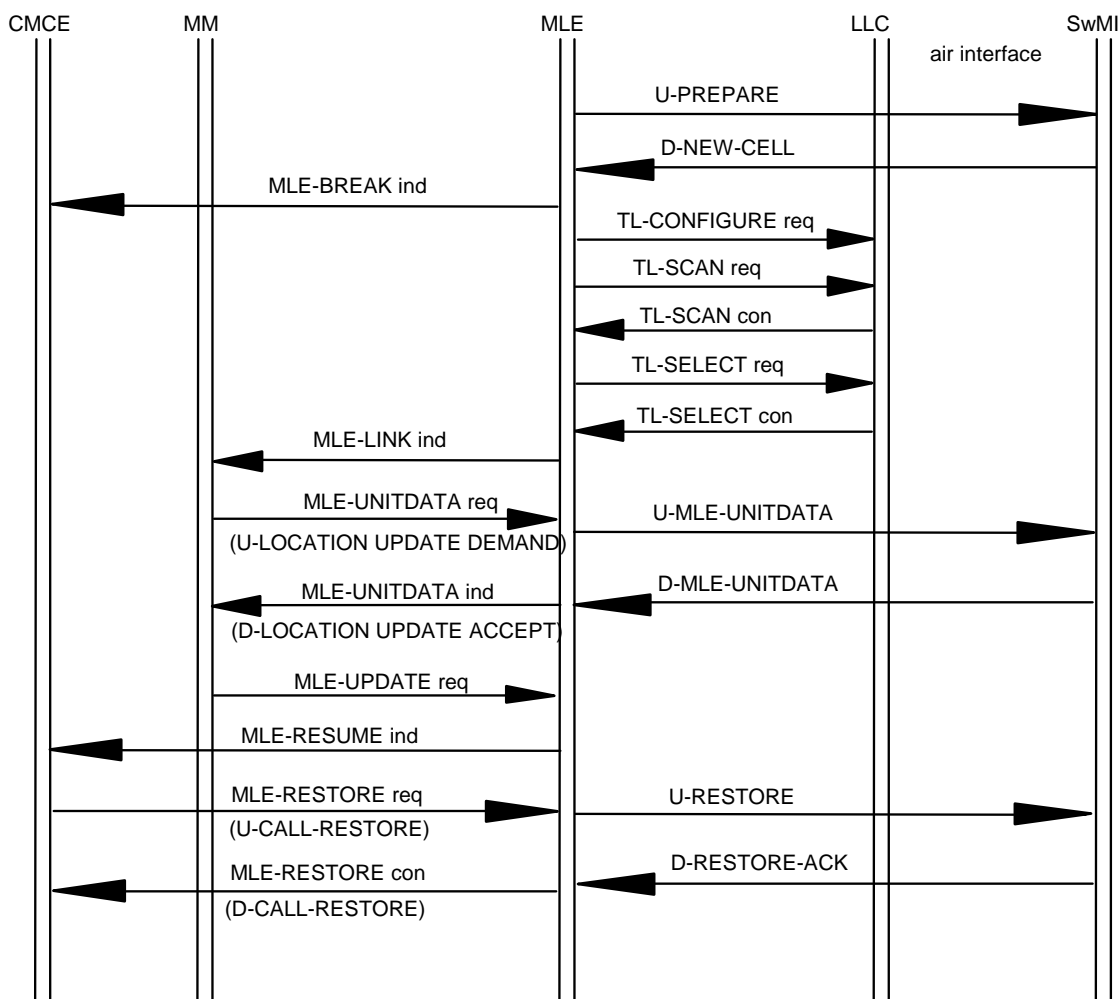


Figure 72: Announced type 3 cell reselection procedure

If timer, T370, expires, the MS shall immediately initiate the cell change procedure as described below.

The SwMI shall not respond to U-PREPARE with D-PREPARE FAIL in the case where the MS-MLE has not indicated a preferred neighbour cell in the U-PREPARE PDU. Therefore D-PREPARE FAIL shall not be a valid response for announced type 3 cell reselection.

## Initiation of the cell change procedure

Upon initiation of the cell change procedure, the MS-MLE shall:

- a) issue MLE-BREAK indication, informing the higher layer 3 entities, SNDCP and CMCE, that the radio link to the current serving cell is unavailable for C-plane signalling;
- b) where the MS does not support advanced link roaming, locally disconnect any advanced links by issuing TL-RELEASE request via the TLA-SAP to layer 2;
- c) initiate foreground scanning of the preferred neighbour cell (which has been selected as a result of monitoring and ranking) to confirm selection;
- d) issue TL-SELECT request via the TLC-SAP to cause the MAC to switch to the main carrier of the new cell; the MAC responds with TL-SELECT confirm once the new cell has been selected.

NOTE 4: If the BS receives U-PREPARE from an MS transmitting in a circuit mode call, the BS may remove the transmit permission by sending D-TX CEASED to the other MS(s) in the cell. Alternatively, the BS may allow the MS changing cell to keep the transmit permission for a period of time or until it selects a new cell and restores the call on that cell.

Registration shall be required if the following conditions are satisfied:

- the preferred neighbour cell does not belong to the same network as the current cell; or
- the preferred neighbour cell is in a LA which is outside the current registered area of the MS; and
- registration is required in the new cell as indicated in the BS service details element which is either received as part of the neighbour cell information in the D-NWRK-BROADCAST PDU or on the new cell in the D-MLE-SYSINFO PDU;
- MS has received a "temporary registration" on the serving cell i.e. MS is temporarily registered, it shall register to the new cell even if the cell belongs to the registered area of the MS;
- the preferred neighbour cell has its "System wide services" parameter set to "System wide services temporarily not supported" - the MS shall register to the new cell even if the cell belongs to the registered area of the MS.

If registration is required, MLE shall issue MLE-LINK indication to MM.

If the registration is to a cell which has its "System wide services" parameter set to "System wide services temporarily not supported" and the registration is accepted with a Location update accept type value of "Temporary registration" then the MS shall consider itself to be temporarily registered.

If the registration result indicates "Cell Rejected", the MLE shall:

- if the rejected cell is the only cell available, the MLE shall re-apply cell reselection procedures; or
- if the rejected cell is not the only cell available, the MLE shall remove the rejected cell from the ranking list may attempt to select another cell from the ranking list and re-apply cell reselection procedures. The rejected cell may only be included again in the ranking list as a result of an attempted reselection to another cell or until the MS is next powered on.

If the registration result indicates "LA Rejected", the MLE shall remove all cells with the LA in this MNC/MCC from the ranking list. The MLE may attempt to select another cell from the ranking list and re-apply cell reselection procedures. In all registration cases, cells with the rejected LA may be included in the ranking list again when one of the following conditions apply:

- after a successful location update to a cell in a different LA;
- until the MS is next powered on.

NOTE 5: Cells with the rejected LA may also be included in the ranking list again after a suitable time or when the LA becomes available through the use of a "denied LA list". An MS may manage such a list, for example, to avoid oscillating between two rejected cells.

If the registration result indicates "System Rejected", the MLE shall remove all cells with the rejected MNC/MCC from the ranking list. The MLE may attempt to select another cell from the ranking list and re-apply cell reselection procedures. In all registration cases, cells with the rejected MNC/MCC may be included in the ranking list again after an attempted reselection to a cell with a different MNC/MCC or until the MS is next powered on.

MM shall indicate successful registration by issuing MLE-UPDATE request to MLE confirming the cell. If registration was successful or if no registration was necessary, MLE shall send MLE-RESUME indication to the upper layer 3 entities, CMCE and SNDCP, to indicate that the radio link is once again available for C-plane signalling.

CMCE may attempt to restore any circuit mode calls which were in existence before the cell change. CMCE shall restore calls by responding to the MLE-RESUME indication primitive with MLE-RESTORE request, containing a CMCE call restoration PDU. MLE shall send a U-RESTORE PDU, containing the CMCE call restoration SDU using the LLC acknowledged service. The U-RESTORE PDU shall contain each of the following elements only if the value on the new cell is different from that on the old cell:

- MNC;
- MCC;
- LA.

If call restoration is successful, MLE shall receive a D-RESTORE ACK PDU from the SwMI which shall contain the CMCE downlink call restoration signalling PDU. Upon receipt of the D-RESTORE ACK PDU indicating successful cell reselection, MLE shall issue MLE-RESTORE confirm to the CMCE. The MLE-RESTORE confirm primitive which is passed to CMCE shall contain the CMCE restoration signalling PDU.

NOTE 6: CMCE may attempt to restore multiple circuit mode calls using the above restoration procedure for each call. Calls are restored one at a time with a call restoration signalling sequence for each one.

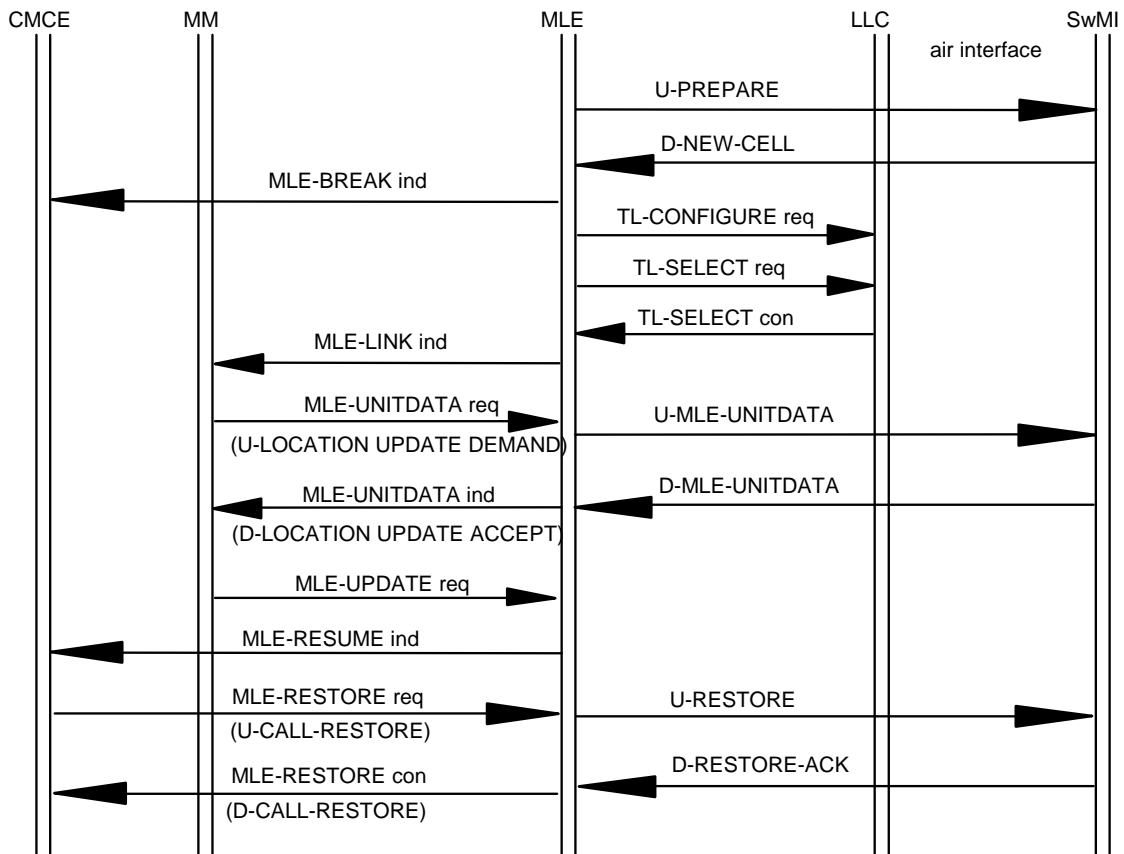
If the D-RESTORE FAIL PDU is received instead, it shall indicate that call restoration was unsuccessful. The "Fail cause" element of the D-RESTORE FAIL PDU shall contain value "Restoration cannot be done on cell". MLE shall then issue MLE-REOPEN indication to the CMCE to indicate that the radio path is restored, but that the call has not been restored. The D-RESTORE FAIL PDU shall not carry an SDU for any of the higher layer 3 entities.

SNDCP may re-establish packet data communications as described in clause 28.3.4.2, by re-establishing an advanced link on the new cell. Where the MS supports advanced link roaming, SNDCP may attempt to reconnect the advanced link as described in clause 28.3.4.4.

#### 18.3.4.7.5 Announced cell reselection - type 2

Announced type 2 cell reselection shall be initiated by an MS if one of the cell reselection criteria described in clause 18.3.4.7 is met and announced type 2 cell reselection is chosen according to the decision tree in figure 70. A preferred neighbour cell shall have been identified by the MS-MLE and shall have been scanned prior to initiating the cell reselection procedure. If cell reselection is initiated as a result of radio link failure or if the preferred neighbour cell has not yet been scanned, announced type 2 cell reselection shall not be attempted by the MS.





**Figure 73: Announced type 2 cell reselection procedure**

Upon initiation of the announced cell reselection type 2 procedure, the MS-MLE shall send a U-PREPARE PDU to the SwMI. The U-PREPARE PDU may carry only a U-OTAR CCK DEMAND SDU. The U-PREPARE PDU shall contain the cell identifier element which shall uniquely identify a cell as defined by the D-NWRK-BROADCAST.

NOTE 1: The fact that the U-PREPARE PDU contains details which identify a preferred neighbour cell informs the SwMI that the MS is attempting announced type 1 or announced type 2 cell reselection. If the MS is already registered in the preferred neighbour cell, the SwMI may direct the MS to a channel on the new cell using a MAC channel allocation thus performing announced type 1 cell reselection.

MLE shall send the U-PREPARE PDU by issuing TL-DATA request to layer 2 with the primitive parameters set as follows:

- PDU priority shall be set to 6;
- stealing permission shall be set to "steal immediately";
- the stealing repeats flag shall not be set.

NOTE 2: By transmitting the U-PREPARE PDU, the MS informs the SwMI that it is about to change cell. The SwMI should also recognise the effect of the cell change on any circuit mode calls that the MS is currently involved in.

The MS may combine an OTAR CCK request with the cell reselection by including a U-OTAR CCK DEMAND PDU within the U-PREPARE PDU as described in clause 4.5.1.3 of EN 300 392-7 [11].

MLE shall start timer, T370, and shall await the response from the SwMI. The SwMI shall respond with D-NEW CELL with the channel command valid element set either to "Change channel immediately", "No channel change" or "Follow MAC channel change".

The MS may receive OTAR CCK information from a D-OTAR CCK PROVIDE PDU within the D-NEW CELL PDU, and process it as described in clause 4.5.1.3 of EN 300 392-7 [11].

If set to "Change channel immediately", MLE shall reset T370 and initiate the cell change procedure described below.

If set to "No channel change", MLE shall restart timer, T370, and wait for another D-NEW-CELL PDU from the SwMI.

The SwMI shall only respond with "Follow MAC channel change" if the MS is already registered in the new cell. In this case, the MS shall then follow the cell change procedures for announced type 1 cell reselection.

If while waiting for D-NEW CELL from the SwMI, radio link failure occurs or timer T370 expires, the MS shall abandon the announcement signalling and shall immediately initiate the cell change procedure described below.

If the MS-MLE receives a D-PREPARE FAIL PDU from the SwMI, the MS-MLE may attempt announced cell reselection to another neighbour cell in the ranking list which meets one of the cell reselection criteria described in clause 18.3.4.7. The "Fail cause" element of the D-PREPARE FAIL PDU shall contain value "Restoration cannot be done on cell", "Temporary break in service" or "MS not allowed on cell".

If the fail cause is "MS not allowed on cell", the MS-MLE shall remove the cell from the ranking list. The rejected cell may only be included again in the ranking list as a result of an attempted reselection to another cell or when the MS is next powered on. If no other cells in the ranking list meet one of the cell reselection criteria or if announced cell reselection fails for all available cells, MLE may continue to use the current serving cell.

If the fail cause is "Restoration cannot be done on cell" (i.e. cell reselection has failed for call-related reasons), either:

- MM shall stay registered on the current serving cell and, if the rejected cell is not the only cell in the ranking list, MLE may attempt to select another cell from the list and re-apply cell reselection procedures. MLE shall not remove the rejected cell from the ranking list but if the rejected cell is chosen as the preferred neighbour cell again during this cell reselection procedure, announced or unannounced cell reselection should not be attempted to that cell; or
- MLE may, if the rejected cell is the only cell in the ranking list, force the call associated with the cell reselection to be dropped and then select the rejected cell using the undeclared cell reselection procedures defined in clause 18.3.4.7.2.

NOTE 3: If the call is dropped, the MS should send U-DISCONNECT on the old cell in case the MS is the call owner of a group call or a party in an individual call.

If the fail cause is "Temporary break in service", (i.e. cell reselection has failed for network related reasons e.g. there is no free traffic channel on the new cell) either:

- MM shall stay registered on the current serving cell and, if the rejected cell is not the only cell in the ranking list, MLE may attempt to select another cell from the list and re-apply cell reselection procedures. MLE shall not remove the rejected cell from the ranking list but if the rejected cell is chosen as the preferred neighbour cell again during this cell reselection procedure, announced cell reselection type 2 should not be attempted to that cell; or
- MLE may, if the rejected cell is the only cell in the ranking list, attempt announced type 3 or unannounced cell reselection to the rejected cell using the procedures defined in clauses 18.3.4.7.4 or 18.3.4.7.3.

#### Initiation of the cell change procedure

Upon initiation of the cell change procedure, the MS-MLE shall:

- a) issue MLE-BREAK indication, informing the higher layer 3 entities, SNDSCP and CMCE, that the radio link to the current serving cell is unavailable for C-plane signalling;
- b) where the MS does not support advanced link roaming, locally disconnect any advanced links by issuing TL-RELEASE request via the TLA-SAP to layer 2;
- c) issue TL-SELECT request via the TLC-SAP to cause the MAC to switch to the main carrier of the new cell; the MAC responds with TL-SELECT confirm once the new cell has been selected.

Registration shall be required if the following conditions are satisfied:

- the preferred neighbour cell does not belong to the same network as the current cell; or
- the preferred neighbour cell is in a LA which is outside the current registered area of the MS; and
- registration is required in the new cell as indicated in the BS service details element which is either received as part of the neighbour cell information in the D-NWRK-BROADCAST PDU or on the new cell in the D-MLE-SYSINFO PDU;
- MS has received a "temporary registration" on the serving cell i.e. MS is temporarily registered, it shall register to the new cell even if the cell belongs to the registered area of the MS;
- the preferred neighbour cell has its "System wide services" parameter set to "System wide services temporarily not supported" - the MS shall register to the new cell even if the cell belongs to the registered area of the MS.

If registration is required, MLE shall issue MLE-LINK indication to MM.

If the registration is to a cell which has its "System wide services" parameter set to "System wide services temporarily not supported" and the registration is accepted with a Location update accept type value of "Temporary registration" then the MS shall consider itself to be temporarily registered.

If the registration result indicates "Cell Rejected", the MLE shall:

- if the rejected cell is the only cell available, the MLE shall re-apply cell reselection procedures; or
- if the rejected cell is not the only cell available, the MLE shall remove the rejected cell from the ranking list may attempt to select another cell from the ranking list and re-apply cell reselection procedures. The rejected cell may only be included again in the ranking list as a result of an attempted reselection to another cell or until the MS is next powered on.

If the registration result indicates "LA Rejected", the MLE shall remove all cells with the LA in this MNC/MCC from the ranking list. The MLE may attempt to select another cell from the ranking list and re-apply cell reselection procedures. In all registration cases, cells with the rejected LA may be included in the ranking list again when one of the following conditions apply:

- after successful location update to a cell in a different LA;
- until the MS is next powered on.

NOTE 4: Cells with the rejected LA may also be included in the ranking list again after a suitable time or when the LA becomes available through the use of a "denied LA list". An MS may manage such a list, for example, to avoid oscillating between two rejected cells.

If the registration result indicates "System Rejected", the MLE shall remove all cells with the rejected MNC/MCC from the ranking list. The MLE may attempt to select another cell from the ranking list and re-apply cell reselection procedures. In all registration cases, cells with the rejected MNC/MCC may be included in the ranking list again after an attempted reselection to a cell with a different MNC/MCC or until the MS is next powered on.

MM shall indicate successful registration by issuing MLE-UPDATE request to MLE confirming the cell. If registration was successful or if no registration was necessary, MLE shall send MLE-RESUME indication to the upper layer 3 entities, CMCE and SNDCP, to indicate that the radio link is once again available for C-plane signalling.

CMCE may attempt to restore any circuit mode calls which were in existence before the cell change. CMCE shall restore calls by responding to the MLE-RESUME indication primitive with MLE-RESTORE request, containing a CMCE call restoration PDU. MLE shall send a U-RESTORE PDU, containing the CMCE call restoration SDU using the LLC acknowledged service. The U-RESTORE PDU shall contain each of the following elements only if the value on the new cell is different from that on the old cell:

- MCC;
- MNC;
- LA.

If call restoration is successful, MLE shall receive a D-RESTORE ACK PDU from the SwMI which shall contain the CMCE downlink call restoration signalling PDU. Upon receipt of the D-RESTORE ACK PDU indicating successful cell reselection, MLE shall issue MLE-RESTORE confirm to CMCE. The MLE-RESTORE confirm primitive which is passed to CMCE shall contain the CMCE restoration signalling PDU.

NOTE 5: CMCE may attempt to restore multiple circuit mode calls using the above restoration procedure for each call. Calls are restored one at a time with a call restoration signalling sequence for each one.

If the D-RESTORE FAIL PDU is received instead, it shall indicate that call restoration was unsuccessful. The "Fail cause" element of the D-RESTORE FAIL PDU shall contain value "Restoration cannot be done on cell". MLE shall then issue MLE-REOPEN indication to the CMCE to indicate that the radio path is restored, but that the call has not been restored. The D-RESTORE FAIL PDU shall not carry an SDU for any of the higher layer 3 entities.

SNDTCP may re-establish packet data communications as described in clause 28.3.4.2, by re-establishing an advanced link on the new cell. Where the MS supports advanced link roaming, SNDTCP may attempt to reconnect the advanced link as described in clause 28.3.4.4.

#### 18.3.4.7.6 Announced cell reselection - type 1

Announced type 1 cell reselection shall be initiated by an MS if one of the cell reselection criteria described in clause 18.3.4.7 is met and announced type 1 cell reselection is chosen according to the decision tree in figure 70 and announced type 1 cell reselection is supported for the preferred neighbour cell as indicated in the D-NWRK-BROADCAST PDU. A preferred neighbour cell shall have been identified by the MS-MLE and shall have been scanned prior to initiating the cell reselection procedure. If cell reselection is initiated as a result of radio link failure, if the preferred neighbour cell has not yet been scanned or if forward registration is not possible (e.g. the preferred neighbour cell is not on the same network), announced type 1 cell reselection shall not be attempted by the MS.

Upon initiation of the announced type 1 cell reselection procedure, the MS shall determine if registration is required in the new cell.

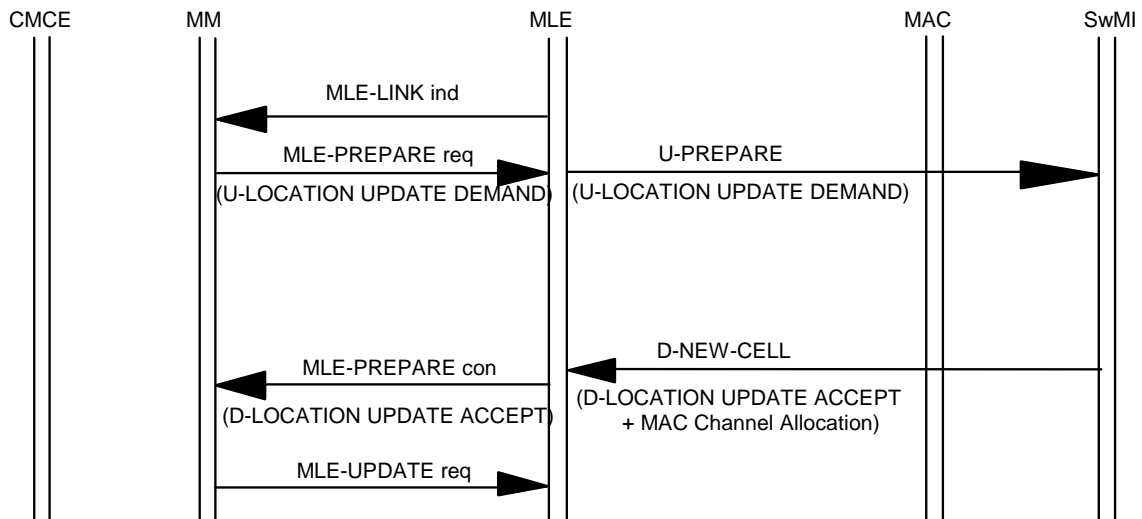
Registration shall be required if the following conditions are satisfied:

- the preferred neighbour cell is in a LA which is outside the current registered area of the MS; and
- registration is required in the new cell as indicated in the BS service details element which is either received as part of the neighbour cell information in the D-NWRK-BROADCAST PDU or on the new cell in the D-MLE-SYSINFO PDU; or
- MS has received a "temporary registration" on the serving cell i.e. MS is temporarily registered, it shall register to the new cell even if the cell belongs to the registered area of the MS;
- the preferred neighbour cell has its "System wide services" parameter set to "System wide services temporarily not supported" - the MS shall register to the new cell even if the cell belongs to the registered area of the MS.

If registration is required, MLE shall issue MLE-LINK indication to MM.

If registration is not required on the new cell, the MS-MLE shall initiate the procedure described in clause 18.3.4.7.5 for announced type 2 cell reselection.

NOTE 1: For the case where an MS is already registered on a preferred neighbour cell, type 1 and type 2 announced cell reselection procedures are initiated by the MS using identical procedures. The MS-MLE sends the U-PREPARE PDU to the SwMI. The SwMI may then decide whether to direct the MS to a TCH or the MCCH on the new cell using a MAC channel allocation (type 1) or simply to allow the MS to select the new cell (type 2).



**Figure 74: Announced type 1 cell reselection procedure**

If registration is required, MLE shall issue MLE-LINK indication to MM which shall have the following parameters:

- MCC of the preferred neighbour cell;
- MNC of the preferred neighbour cell;
- LA of the preferred neighbour cell;
- registration type shall be set to "forward" to indicate that forward registration (i.e. registration in a cell other than the current serving cell) is required.

If the MS has received a "Temporary registration" acknowledgement for the serving cell, it shall register to the new cell even if the cell belongs to the Registered Area of the MS.

The MM shall then initiate forward registration by issuing MLE-PREPARE request which shall have a registration SDU as a parameter. MLE shall then send a U-PREPARE PDU to the SwMI which shall contain the MM registration SDU. The U-PREPARE PDU shall contain the cell identifier element which shall uniquely identify a cell as defined by the D-NWRK-BROADCAST PDU. MLE shall start timer T370 and shall await the response from the SwMI. The SwMI shall respond with D-NEW CELL with the channel command valid element set to "Change channel immediately", "No channel change" or "Follow MAC channel change".

**NOTE 2:** The fact that the U-PREPARE PDU contains details which identify a preferred neighbour cell informs the SwMI that the MS is attempting announced type 2 or announced type 1 cell reselection. If the MS is already registered on the preferred neighbour cell, the SwMI may direct the MS to the MCCH or to the TCH on the new cell using a MAC channel allocation. If the PDU carries a registration SDU, this informs the SwMI that the MS is requesting a type 1 cell reselection. However, even in this case, the SwMI may decide to direct the MS to a channel on the new cell using a MAC channel allocation (type 1 reselection) or simply indicate the MS is free to select the new cell (type 2 reselection) and switch to the MCCH of that cell. The SwMI therefore ultimately controls whether type 1 or type 2 cell reselection is applied.

**NOTE 3:** By transmitting the U-PREPARE PDU, the MS informs the SwMI that it is about to change cell. The SwMI should also recognise the effect of the cell change on any circuit mode calls that the MS is currently involved in.

If cell reselection is successful, the SwMI may respond to the combined registration and cell reselection preparation in one of two ways as follows:

1) Successful type 1 cell reselection:

- the SwMI shall respond with a D-NEW CELL PDU which shall contain an MM SDU accepting registration on the new cell. The MM SDU shall be passed to MM using MLE-PREPARE confirm. MLE-UPDATE request shall then indicate successful registration to MLE;
- upon reception of D-NEW CELL, MS-MLE shall initiate the cell change procedure as follows:
  - a) issue MLE-BREAK indication, informing the higher layer 3 entity, SNDCP, that the radio link to the current serving cell is unavailable for C-plane signalling;
  - b) where the MS does not support advanced link roaming, locally disconnect any advanced links by issuing TL-RELEASE request via the TLA-SAP to layer 2.
- the "Channel command valid" element in the D-NEW-CELL PDU shall be set to "Follow MAC channel allocation" to indicate that a TCH has been allocated on the new cell to continue the circuit mode call or that the MS has to switch to the MCCH of the new cell to continue the call. The MAC shall automatically follow the channel allocation in the MAC header. The MS shall continue the call on the new cell assuming the same U-plane/C-plane mode and transmit permission as it had on the old cell unless it has been directed to the MCCH on the new cell (i.e. the MS shall not assume that U-plane mode continues on MCCH);
- the MAC indicates the channel change using TL-SELECT indication to which the MLE shall respond with TL-SELECT response containing a parameter to inform to the MAC of the main carrier frequency on the new cell. On receiving TL-SELECT indication indicating that the channel change has been completed by the MAC, the MLE shall send indication to SNDCP to indicate that the radio link is once again available for C-plane signalling.

NOTE 4: In this case, there shall be no need for the MS to send call restoration signalling on the new cell. If the SwMI directs the MS to the MCCH, the SwMI should then later complete the call restoration by directing the MS to a traffic channel.

2) Successful type 2 cell reselection:

- the SwMI may accept registration on the new cell but not direct the MS to a channel on the new cell rather the MS switches autonomously to the MCCH of the new cell. In this case the SwMI shall respond with a D-NEW CELL PDU which shall contain an MM SDU accepting registration on the new cell. The MM SDU shall be passed to MM using MLE-PREPARE confirm. MLE-UPDATE request shall indicate successful registration to MLE;
- the Channel command valid element shall be set to "Change channel immediately" which shall cause the MS to initiate the cell change procedure as follows:
  - a) issue MLE-BREAK indication, informing the higher layer 3 entities, SNDCP and CMCE, that the radio link to the current serving cell is unavailable for C-plane signalling;
  - b) where the MS does not support advanced link roaming, locally disconnect any advanced links by issuing TL-RELEASE request via the TLA-SAP to layer 2;
  - c) issue TL-SELECT request via the TLC-SAP to cause the MAC to switch to the main carrier of the new cell; the MAC responds with TL-SELECT confirm once the new cell has been selected;
  - d) issue MLE-RESUME indication to the upper layer 3 entities, CMCE and SNDCP to indicate that the radio link is once again available for C-plane signalling.

CMCE may then attempt to restore circuit mode calls by applying the same call restoration procedure as is used for announced type 2 cell reselection.

If the SwMI responds to the U-PREPARE PDU with a D-NEW CELL PDU which has the "Channel command valid" element set to "No channel change", MLE shall restart timer T370 and shall wait for a further D-NEW CELL PDU from the SwMI. The "No channel change" D-NEW CELL shall not contain a MM SDU.

Following the initial "No channel change" D-NEW CELL PDU, the SwMI may continue to refresh timer T370 by sending further "No channel change" D-NEW CELL PDUs. However, it is recommended that the total amount of time the SwMI keeps the MS waiting for a D-NEW CELL PDU with "Channel command valid" element set to "Change channel immediately" or "Follow MAC channel change" is less than the duration of timer T351 (the registration response time) - refer to clause 16.11.1.1. A "Change channel immediately" or "Follow MAC channel change" D-NEW CELL PDU received after a "No channel change" D-NEW CELL PDU shall contain a MM SDU and shall be handled as defined in:

- 1) "Successful type 1 cell reselection"; and
- 2) "Successful type 2 cell reselection" of this clause.

As a response to U-PREPARE or following the initial D-NEW CELL PDU indicating "No channel change" (and any subsequent "No channel change" D-NEW CELL PDUs), the SwMI may reject the cell reselection by sending a D-PREPARE FAIL PDU with appended MM D-LOCATION UPDATE REJECT PDU - refer to the description of unsuccessful announced type 1 cell reselection below.

If while waiting for a D-NEW CELL PDU from the SwMI, radio link failure occurs or timer T370 expires, the MS shall abandon the announcement signalling and shall immediately initiate the cell change procedure described in clause 18.3.4.7.5, after the label "Initiation of the cell change procedure".

If the registration is to a cell which has its "System wide services" parameter set to "System wide services temporarily not supported" and the registration is accepted with a Location update accept type value of "Temporary registration" then the MS shall consider itself to be temporarily registered.

#### Unsuccessful announced type 1 cell reselection

If cell reselection is not successful, the SwMI shall respond to the MS with a D-PREPARE FAIL PDU which shall carry an MM PDU rejecting registration on the new cell. The "Fail cause" element of the D-PREPARE FAIL PDU may contain any of the values specified in clause 18.5.7, "Fail cause".

If the "Fail cause" element of the D-PREPARE FAIL PDU contains value "Temporary break in service", "Cell reselection type not supported" or "Restoration cannot be done on cell", the "Reject cause" element of the D-LOCATION UPDATE REJECT PDU shall have value "Forward registration failure".

If the "Fail cause" element of the D-PREPARE FAIL PDU contains value "MS not allowed on cell" then the "Reject cause" element of the D-LOCATION UPDATE REJECT PDU shall have any value other than "Forward Registration failure".

The MM SDU shall be passed to MM using MLE-PREPARE confirm. MLE-UPDATE request shall then inform MLE that the cell reselection was not successful.

If the registration result indicates "Cell Rejected" (refer to clause 16.10.42), MM shall stay registered on the current serving cell. MLE shall remove the rejected cell from the ranking list; if, following this action, the ranking list still contains other cells, MLE may attempt to select another cell from the list and reapply cell reselection procedures, The rejected cell may only be included again in the ranking list as a result of an attempted reselection to another cell or when the MS is next powered on.

If the registration reject cause is "Forward registration failure" and the "Fail cause" element of the associated D-PREPARE FAIL PDU is "Restoration cannot be done on cell" (i.e. forward registration has failed for call-related reasons), either:

- MM shall stay registered on the current serving cell and, if the rejected cell is not the only cell in the ranking list, MLE may attempt to select another cell from the list and re-apply cell reselection procedures. MLE shall not remove the rejected cell from the ranking list but if the rejected cell is chosen as the preferred neighbour cell again during this cell reselection procedure, announced or unannounced cell reselection should not be attempted to that cell; or
- MLE may, if the rejected cell is the only cell in the ranking list, force the call associated with the forward registration to be dropped and then select the rejected cell using the undeclared cell reselection procedures defined in clause 18.3.4.7.2.

NOTE 5: If the call is dropped, the MS should send U-DISCONNECT on the old cell in case the MS is the call owner of a group call or a party in an individual call.

If the registration reject cause is "Forward registration failure" and the "Fail cause" element of the associated D-PREPARE FAIL PDU is "Temporary break in service" (i.e. forward registration has failed for network related reasons e.g. there is no free traffic channel on the new cell), either:

- MM shall stay registered on the current serving cell and, if the rejected cell is not the only cell in the ranking list, MLE may attempt to select another cell from the list and re-apply cell reselection procedures. MLE shall not remove the rejected cell from the ranking list but if the rejected cell is chosen as the preferred neighbour cell again during this cell reselection procedure, announced cell reselection type 1 should not be attempted again to that cell; or
- MLE may, if the rejected cell is the only cell in the ranking list, attempt announced type 2, type 3 or unannounced cell reselection to the rejected cell using the procedures defined in clauses 18.3.4.7.5 after the label "Initiation of the cell change procedure", 18.3.4.7.4 after the label "Initiation of the cell change procedure" or clause 18.3.4.7.3.

If the registration reject cause is "Forward registration failure" and the "Fail cause" element of the associated D-PREPARE FAIL PDU is "Cell reselection type not supported", (i.e. forward registration has failed for network related reasons), the MS-MLE shall issue a MLE-BREAK indication to inform the higher layer 3 entity CMCE that the radio link to the current serving cell is unavailable for C-plane signalling and shall then proceed with the initiation of the cell change procedure including registration and call restoration on the new cell as defined in clause 18.3.4.7.4, after the label "Initiation of the cell change procedure".

If the registration result indicates "LA Rejected", the MLE shall remove all cells with the LA in this MNC/MCC from the ranking list. The MM shall stay registered on the current serving cell. The MLE may attempt to select another cell from the ranking list and re-apply cell reselection procedures. In all registration cases, cells with the rejected LA may be included in the ranking list again when one of the following conditions apply:

- after a successful location update to a cell in a different LA;
- until the MS is next powered on.

NOTE 6: Cells with the rejected LA may also be included in the ranking list again after a suitable time or when the LA becomes available through the use of a "denied LA list". An MS may manage such a list, for example, to avoid oscillating between two rejected cells.

If the registration result indicates "System Rejected", the MLE shall remove all cells with the rejected MNC/MCC from the ranking list. The MS remains registered on the current serving cell. The MLE may attempt to select another cell from the ranking list and re-apply cell reselection procedures. In all registration cases, cells with the rejected MNC/MCC may be included in the ranking list again after an attempted reselection to a cell with a different MNC/MCC or until the MS is next powered on.

All other combinations of D-NEW CELL/D-PREPARE FAIL and MM registration PDUs shall not be sent by the SwMI during announced type 1 cell reselection.

SNDCP may re-establish packet data communications as described in clause 28.3.4.2 of the present document, by re-establishing an advanced link on the new cell. Where the MS supports advanced link roaming, SNDCP may attempt to reconnect the advanced link as described in clause 28.3.4.4 of the present document.

### 18.3.4.8 Change of broadcast parameters by the SwMI

Changes in broadcast parameters by the SwMI affects the behaviour of the MS. The broadcast parameters that affect MLE and the other layer 3 entities are obtained from the SYSINFO PDU. The parameters fall into two categories:

- information about the general services that are supported by the SwMI on a particular cell e.g. BS service details;
- information concerning the security services that are supported by the SwMI on a particular cell e.g. security information in extended services broadcast.

The behaviour of the MS is dependent upon the broadcast parameter that has changed. MLE shall determine if the parameter(s) that has changed requires the MS to re-register, whereby MLE shall issue a MLE-LINK indication to MM.

If the status of the cell changes from "System wide services temporarily not supported" to "Normal mode" and the MS is temporarily registered with the cell then the MLE shall indicate a need for periodic registration to MM.



The behaviour of the MS when there is a change in the security parameters is defined in EN 300 392-7 [11].

In addition to the above, MLE shall inform MM, CMCE and SNDCP of the change in broadcast parameter(s) via a MLE-INFO indication service primitive.

## 18.3.5 Data transfer sub-entity

The services and primitives offered by the MLE are described in clause 17.

### 18.3.5.1 Address handling

The MLE manages all of the subscriber addresses (i.e. ITSIs and GTSIs) plus the management identity (i.e. TMI). These addresses and identities are described in EN 300 392-1 [9], clause 7.

System subscriber Identities which are received or attached and detached by the MM entity should be transferred to MLE in an MLE-IDENTITIES request primitive. After being recorded locally and any lists amended, the list of currently valid short subscriber and management identities shall be transferred to the lower layers via the TLC-SAP in a TL-CONFIGURE request primitive as described in clause 18.3.5.1.2.

Active group system subscriber identities which are received by the SS sub-entity shall be transferred to MLE in an MLE-IDENTITIES request primitive. After being recorded locally and any lists amended, the list of currently valid short subscriber and management identities shall be transferred to the lower layers via the TLC-SAP in a TL-CONFIGURE request primitive as described in clause 18.3.5.1.2. The MLE-IDENTITIES request primitive from the LCMC-SAP contains request to add and/or remove group identities

Temporary group addresses allocated by SwMI or assumed by MS when setting up a group call, is informed to MLE by CMCE using the MLE-CONFIGURE request primitive. The MLE-CONFIGURE request primitive from the LCMC-SAP contains request to add and/or remove temporary group identities. The updated lists shall be transferred to the lower layers via the TLC-SAP in a TL-CONFIGURE request primitive as described in clause 18.3.5.1.2.

#### 18.3.5.1.1 Link addressing

The MLE defines the MAIN ADDRESS and the ADDRESS TYPE parameters in all TL-CONNECT, TL-DATA, TL-DISCONNECT and TL-UNITDATA primitives issued to layer 2. The MAIN ADDRESS shall comprise of a valid SSI.

For messages containing higher layer information, the MLE sets the MAIN ADDRESS SSI parameter to a valid SSI, as defined in EN 300 392-1 [9], clause 7. During migration, exchanged addresses shall be used, using the exchanged addresses issued by the MM in the MLE-IDENTITIES request primitive.

If there is no valid SSI the MLE shall use an un-exchanged SSI (USSI) as defined in EN 300 392-1 [9], clause 7. An un-exchanged SSI may only be used for MM messages, refer clause 23.4.1.2.5.

For messages from the MLE management entity, the MLE shall always add the SMI. The SMI is defined in EN 300 392-1 [9], clause 7.

The MLE shall remove the MAIN ADDRESS and the ADDRESS TYPE parameters from all primitives received from layer 2. These parameters can be used for upward routing. In the service primitives to layer 3 MLE shall use ITSIs or GTSIs as appropriate.

#### 18.3.5.1.2 Link addresses to be placed in layer 2

In order to be able to filter, in layer 2, those messages received by the MS that are not applicable, layer 2 requires to be informed of all addresses that are valid for the MS. The MLE shall inform layer 2 by means of a TL-CONFIGURE request the short subscriber and management identities that are valid for the MS.

In the event that a SSI ceases to be valid, then the MLE shall inform layer 2 by means of a TL-CONFIGURE request via the TLC-SAP.

### 18.3.5.1.3 Layer 2 end point identifier

The MLE receives the layer 2 endpoint identifier in all primitives exchanged with the layer 2. Endpoint identifier is assumed to be a local layer-to-layer matter, and is not defined in the present document.

Endpoint identifiers uniquely identify radio resources, not fixed radio channels or timeslots.

### 18.3.5.1.4 Subscriber class

The MM informs the MLE of the MS subscriber class membership for a particular ITSI using an MLE-INFO request primitive. The MLE shall then use this value to determine if there is a match between the subscriber class being broadcasted by the SwMI and the subscriber class of the MS. The subscriber class is a bit mapped field which shall indicate which subscriber classes the MS is a member of. The values are specified in clause 18.5. The subscriber class parameter may be allocated at subscription or registration. If the MS does not have a subscriber class from registration or subscription, the MS shall assume membership of all subscriber classes. The indication of whether there is a subscriber class match shall be indicated by MLE to the other layer 3 entities via the MLE-INFO indication service primitive.

## 18.3.5.2 MLE connection handling

An MLE connection is the logical association of the MLE peer entities in the MS/LS and the SwMI. The association is made by the mobile when it acquires a radio channel and camps on a cell. No explicit signalling is required in order to establish the connection.

### 18.3.5.2.1 Data transfer states

The following states shall exist in the data transfer entity.

NOTE 1: In the state machine the states themselves are provided for information, but conformance to the signalling specified for the output of the state machine is a requirement.

NOTE 2: These states are the MLE state machine states, which are different to the service states presented in clause 17.

a) Closed:

- the data transfer sub-entity shall enter state Closed after initial start up. This state shall also be entered after an MLE-CLOSE request has been received from the MM entity indicating that there shall be no access to communication resources allowed.

b) All Data:

- the data transfer sub-entity shall enter the state All Data if it has received an MLE-OPEN request and has not subsequently received an MLE-CLOSE request or MLE-BREAK indication.

c) Broken:

- the data transfer sub-entity enters this state upon receipt of an MLE-BREAK indication from the attachment management sub-entity and indicates that the connection is temporarily broken. Upon receiving an MLE-RESUME indication or an MLE-REOPEN indication the data transfer sub-entity shall return to the all data state.

## 18.3.5.3 Selection of LLC services

### 18.3.5.3.1 Selection of LLC services via TLA-SAP

Two types of data transfer are available at the layer 2 TLA-SAP:

- acknowledged PDU transfer; and
- unacknowledged PDU transfer.

The acknowledged service provides bidirectional data transfer, the unacknowledged service is unidirectional.

The required service shall be interpreted from the information contained in the primitives from the higher entities according to the procedures specified below.

The PDU priority, stealing permission and stealing repeats flag parameters shall be set by the sending higher layer 3 entity and simply passed on to layer 2 by the MLE. In addition, for TL-CONNECT and TL-DISCONNECT primitives which are issued by the MLE, the stealing permission parameter shall be set to "stealing not required" and the stealing repeats flag shall not be set. The PDU priority shall be equal to 3 for TL-CONNECT and 6 for TL-DISCONNECT.

SNDCP uses both basic and advanced link services in the layer 2. The discrimination between the link types is based on the SN-PDU type and it is defined in clause 28. The following clauses define the SNDCP data transfer functionality for basic link and advanced link separately.

#### a) Outgoing messages from MM and CMCE

All outgoing messages shall be subject to the following handshake procedure with the LLC.

MLE shall allocate a handle to all TL-DATA requests. Upon receipt of the TL-DATA request primitive the LLC may immediately acknowledge this with a TL-REPORT indication containing the same handle as in the request, refer to clause 22.3.3.2.6. The handle shall be retained locally and used for routing subsequent MLE-REPORT indication primitives. The handle remains valid until a TL-DATA confirm is received indicating that the PDU has been (successfully) transmitted, or, a TL-CANCEL request is issued when the handle is deleted. TL-CANCEL requests may be issued until the receipt of the TL-REPORT indication with reason "first complete transmission" or "failed transfer".

On receipt of TL-REPORT indication indicating successful transmission, the MLE shall issue MLE-REPORT indication to the SAP which sent the original TL-DATA request primitive to inform the higher layer 3 entity that the PDU has been successfully transmitted by layer 2.

On receipt of an MLE-UNITDATA request, the data transfer sub-entity shall append an MLE PDU header indicating the originating SAP using the protocol discriminator field. The PDU header values are defined in clause 18.4.2. The data transfer sub-entity shall determine the length of the PDU and pass that information to the LLC as a primitive parameter.

The underlying service selected shall be the basic link or advanced link and determined according to the L2 service parameter in the MLE-UNITDATA request primitive. The MLE shall set-up an advanced link when needed by MM and/or CMCE.

If the L2 service request parameter has the value "acknowledged request" then the MLE UNITDATA PDU shall be transferred to the LLC in a TL-DATA request primitive.

If the L2 service request parameter has the value "acknowledged response" then the MLE UNITDATA PDU shall be transferred to the LLC in a TL-DATA response primitive.

If the L2 service request parameter has the value "unacknowledged" then the MLE UNITDATA PDU shall be transferred to the LLC in a TL-UNITDATA request primitive.

On receipt of an MLE-CANCEL request primitive from the CMCE or MM SAP, the data transfer sub-entity shall issue a TL-CANCEL request primitive to the TLA-SAP. Once the TL-CANCEL request has been issued any references to the handle in the MLE shall be deleted.

The basic link shall be used for all MM signalling and CMCE call related signalling. The FCS flag may be set to indicate the use of the optional FCS for basic link transfer. Whether or not the optional FCS is selected for basic link transfer is not defined in the present document.

The advanced link may also be used for transfer of long SDUs. This may be required for the short data service which can send up to 2 047 bits of data or for transfer of SS information. A separate or the same advanced link can be used by MM and/or CMCE to that used by SNDCP for packet data transfer.

NOTE 1: CMCE SDS and SS information may be up-linked to the BS on an existing advanced link which was negotiated on behalf of packet data entity at some earlier time;

NOTE 2: The MLE may negotiate an advanced link specifically for the up-linking of CMCE SDS and SS signalling.

### b) Incoming messages to MM and CMCE

On receipt of a TL-UNITDATA indication, the data transfer sub-entity shall remove and analyse the MLE PDU header and address. The PDU header indicates the destination SAP. The address may indicate that this is a network broadcast message. The data contained in the TL-UNITDATA indication shall then be routed to the correct SAP or sub-entity as an MLE-UNITDATA indication primitive. Network broadcast D-NWRK-BROADCAST messages shall be routed by the data transfer sub-entity to the network broadcast sub-entity. Late entry information from the D-MLE-SYNC PDU shall be routed to the CMCE SAP.

On receipt of a TL-DATA indication, the data transfer sub-entity shall remove and analyse the MLE PDU header. The PDU header indicates the destination SAP. The data contained in the TL-DATA indication shall then be routed to the correct SAP or sub-entity as an MLE-UNITDATA-indication primitive.

On receipt of a TL-DATA confirm, the MLE shall issue an MLE-REPORT indication primitive to indicate successful transmission of the PDU transmitted as a result of the previous TL-DATA request as indicated by the "handle to the request" parameter. The data transfer sub-entity shall then remove and analyse the MLE PDU header. The PDU header indicates the destination SAP. The data contained in the TL-DATA indication shall then be routed to the correct SAP or sub-entity as an MLE-UNITDATA-indication primitive.

### c) Outgoing basic link messages from SNDPCP

The data transfer sub entity shall reject service requests when in state closed. When in the broken state, messages shall not be passed by the MLE.

All outgoing messages shall be subject to the following handshake procedure with the LLC.

MLE shall allocate a handle to all TL-DATA and TL-UNITDATA requests. Upon receipt of the TL-DATA, or TL-UNITDATA request primitive the LLC may immediately acknowledge this with a TL-REPORT indication containing the handle, refer to 22.3.3.2.6. The handle shall be retained locally and used for routing subsequent MLE-REPORT indication primitives.

Where the outgoing message has resulted in the MLE requesting an unacknowledged service from the LLC, the handle remains valid until a further TL-REPORT indication is received indicating that the PDU has been transmitted, or, a TL-CANCEL request is issued when the handle is deleted.

Where the outgoing message has resulted in the MLE requesting an acknowledged service from the LLC, the handle remains valid until a TL-DATA confirm is received indicating that the PDU has been successfully transmitted, or, a TL-CANCEL request is issued when the handle is deleted. TL-CANCEL requests may be issued until the receipt of the second TL-REPORT indication with, even though the handle remains valid in the latter case.

On receipt of a TL-DATA confirm, the MLE shall issue an MLE-REPORT indication indicating successful transmission of the PDU transmitted as a result of the previous TL-DATA request on that endpoint identifier. If the TL-DATA confirm contains an SDU, this shall then be passed to the higher layers using MLE-UNITDATA indication.

On receipt of an MLE-UNITDATA request, the data transfer sub entity shall append an MLE PDU header indicating the originating SAP using the protocol discriminator field. The protocol discriminator values are defined in clause 12.5.2.1 of the present document. The data transfer sub entity shall determine the length of the PDU and pass that information to the LLC as a primitive parameter.

If the L2 service request parameter has the value "acknowledged request" then the MLE UNITDATA PDU shall be transferred to the LLC in a TL-DATA request primitive.

If the L2 service request parameter has the value "acknowledged response" then the MLE UNITDATA PDU shall be transferred to the LLC in a TL-DATA response primitive.

If the L2 service request parameter has the value "unacknowledged" then the MLE UNITDATA PDU shall be transferred to the LLC in a TL-UNITDATA-request primitive.

Whether or not the optional FCS is selected in basic link transfer is not defined in the present document.

The SDU shall be sent to the TLA SAP in a TL-DATA request primitive unless an unacknowledged data transfer is specifically requested, in which case the SDU shall be sent in a TL-UNITDATA request primitive.

#### d) Incoming basic link messages to SNDCCP

On receipt of a TL-UNITDATA indication, the data transfer sub-entity shall remove and analyse the MLE PDU header and address. The PDU header indicates the destination SAP. The data contained in the TL-UNITDATA indication shall then be routed to the correct SAP or sub-entity as an MLE-UNITDATA indication primitive.

On receipt of a TL-DATA indication, the data transfer sub-entity shall remove and analyse the MLE PDU header. The PDU header indicates the destination SAP. The data contained in the TL-DATA indication shall then be routed to the correct SAP or sub-entity as an MLE-UNITDATA indication primitive.

On receipt of a TL-DATA confirm, the MLE shall issue an MLE-REPORT indication primitive to indicate successful transmission of the PDU transmitted as a result of the previous TL-DATA request on that endpoint identifier. The data transfer sub-entity shall then remove and analyse the MLE PDU header. The PDU header indicates the destination SAP. The data contained in the TL-DATA confirm shall then be routed to the correct SAP or sub-entity as an MLE primitive, as determined by the MLE PDU header. MLE-UNITDATA PDUs are routed to the appropriate SAP in MLE-UNITDATA indication primitives.

#### e) Outgoing advanced link messages from SNDCCP

The data transfer sub entity shall reject service requests when in state closed. When in the broken state, messages shall not be passed by the MLE.

All outgoing messages shall be subject to the following handshake procedure with the LLC.

Upon receipt of the TL-CONNECT, TL-DISCONNECT, TL-DATA, TL-RECONNECT or TL-UNITDATA request primitive the LLC will immediately acknowledge this with a TL-REPORT indication containing the handle. The handle shall be retained locally and used for routing subsequent REPORT primitives. Where the outgoing message has resulted in the MLE requesting an unacknowledged service from the LLC, the handle remains valid until a further TL-REPORT indication is received indicating that the PDU has been transmitted, or, a TL-CANCEL request is issued when the handle is deleted. Where the outgoing message has resulted in the MLE requesting an acknowledged service from the LLC, the handle remains valid until a TL-DATA confirm is received indicating that the PDU has been successfully transmitted, or, a TL-CANCEL request is issued when the handle is deleted. TL-CANCEL requests may be issued until the receipt of the second TL-REPORT indication, even though the handle remains valid in the latter case.

On receipt of a TL-DATA confirm, the MLE shall issue an MLE-REPORT indication indicating successful transmission of the PDU transmitted as a result of the previous TL-DATA request on that endpoint identifier. If the TL-DATA confirm contains an SDU, this shall then be passed to the higher layers using MLE-UNITDATA indication.

The SNDCCP shall use the advanced link to ensure reliable transmission of long packets (i.e. longer than about 3 TDMA slots worth of data). The MS shall only attempt to set up an advanced link if both the SwMI supports SNDCCP operation and if the advanced link is supported by the SwMI on this cell. This information is indicated in the BS service details element broadcast as part of the D-MLE SYSINFO PDU. If either SNDCCP or the advanced link is not supported by the SwMI on this cell then the LTPD-SAP shall be closed (MLE-Close indication issued).

The quality of service parameters passed down by SNDCCP using MLE-CONNECT request shall be used by the MS in negotiating the advanced link service during set-up. How the SNDCCP QoS parameters map onto the advanced link quality of service selection in the AL-SETUP PDU is not defined by the present document.

On receipt of a MLE-CONNECT request from SNDCCP, the data transfer subentity shall issue a TL-CONNECT request to the TLA-SAP. Upon receipt of the corresponding TL-CONNECT confirm, the data transfer subentity shall issue a MLE-CONNECT confirm to SNDCCP.

On receipt of a MLE-DISCONNECT request from SNDCCP, the data transfer subentity shall issue a TL-DISCONNECT request to the TLA-SAP. Upon receipt of the corresponding TL-DISCONNECT confirm, the data transfer subentity shall issue a MLE-DISCONNECT indication to SNDCCP.

On receipt of a MLE-RECONNECT request from SNDCCP, the data transfer subentity shall issue a TL-RECONNECT request to the TLA-SAP. Upon receipt of the corresponding TL-RECONNECT confirm, the data transfer subentity shall issue a MLE-RECONNECT indication to SNDCCP.

On receipt of an MLE-UNITDATA request, the data transfer sub entity shall append an MLE PDU header indicating the originating SAP using the protocol discriminator field. The protocol discriminator values are defined in clause 18. The data transfer sub entity shall determine the length of the PDU and pass that information to the LLC as a primitive parameter.

If the L2 service request parameter has the value "acknowledged request" then the MLE UNITDATA PDU shall be transferred to the LLC in a TL-DATA request primitive.

For messages using the advanced link, the L2 service request parameter shall not be set to "acknowledged response".

If the L2 service request parameter has the value "unacknowledged" then the MLE UNITDATA PDU shall be transferred to the LLC in a TL-UNITDATA-request primitive.

On receipt of a MLE-RELEASE request from SNDCCP, the data transfer subentity shall issue a TL-RELEASE request to the TLA-SAP. All references to the advanced link in question shall be deleted.

#### f) Incoming advanced link messages to SNDCCP

On receipt of a TL-CONNECT indication, the data transfer sub entity shall issue MLE-CONNECT indication to the SNDCCP.

On receipt of a TL-CONNECT confirm, the data transfer sub entity shall issue MLE-CONNECT confirm to the SNDCCP.

On receipt of a TL-RECONNECT confirm, the data transfer sub entity shall issue MLE-RECONNECT confirm to the SNDCCP.

On receipt of a TL-DISCONNECT indication, the data transfer sub entity shall issue MLE-DISCONNECT indication to the SNDCCP if the TL-DISCONNECT indication refers to an established advanced link. This can be established by using the endpoint identifier. If it does refer to an established advanced link, any local reference to that advanced link shall be deleted.

On receipt of a TL-DISCONNECT confirm, the data transfer sub entity shall issue MLE-DISCONNECT indication to the SNDCCP.

On receipt of a TL-UNITDATA indication, the data transfer sub entity shall remove and analyse the MLE PDU header and address. The PDU header indicates the destination SAP. The data contained in the TL-UNITDATA indication shall then be routed to the correct SAP or sub entity as an MLE-UNITDATA indication primitive.

On receipt of a TL-DATA indication, the data transfer sub entity shall remove and analyse the MLE PDU header. The PDU header indicates the destination SAP. The data contained in the TL-DATA indication shall then be routed to the correct SAP or sub entity as an MLE-UNITDATA indication primitive.

On receipt of a TL-DATA confirm, the MLE shall issue an MLE-REPORT indication primitive to indicate successful transmission of the PDU transmitted as a result of the previous TL-DATA request on that endpoint identifier. The data transfer sub entity shall then remove and analyse the MLE PDU header. The PDU header indicates the destination SAP. The data contained in the TL-DATA confirm shall then be routed to the correct SAP or sub entity as an MLE primitive, as determined by the MLE PDU header. MLE-UNITDATA PDUs are routed to the PDP-SAP in MLE-UNITDATA indication primitives.

#### 18.3.5.3.2 Selection of LLC services via TLB-SAP

There are no services available at the TLB-SAP in the MS.

Data received via the TLB-SAP is routed to the network broadcast sub-entity and is dealt with in clause 18.3.6.

#### 18.3.5.3.3 Selection of LLC services via TLC-SAP

##### a) Locally generated TL-CONFIGURE requests

The data transfer sub-entity shall supply TL-CONFIGURE requests primitives to the TLC-SAP to inform the lower layers of the state of any MM signalling or circuit mode calls in progress. The MLE-Activity indicator allows the lower layers to decide when to apply energy economy.

NOTE: It is possible to apply an energy economy scheme that has been notified to, and agreed by, the SwMI.

The TL-CONFIGURE request shall be sent with the MLE-Activity indicator parameter set when there is any explicit or implicit connection active. The TL-CONFIGURE request primitive may only be sent with the MLE-Activity indicator parameter cleared when there is no MM or circuit mode call activity.

An advanced link shall become active when one of the following occurs:

- TL-CONNECT request is sent and MLE is awaiting TL-CONNECT confirm;
- TL-CONNECT response is sent.

The advanced link shall be considered to be active until one of the following occurs:

- TL-DISCONNECT confirm is received;
- a TL-RELEASE indication is received;
- a TL-RELEASE request is sent.

A group circuit mode call remains active until it is disconnected by the MS, released by the SwMI or locally released (without any signalling with the SwMI). An individual circuit mode call remains active until it is disconnected by the MS or released by the SwMI.

#### b) Locally received TL-SELECT indications

Where the MLE receives a TL-SELECT indication via the TLC-SAP indicating that the MAC has been instructed to change channels and no response is required, this is dealt with in clause 18.3.4.3.

The only case where the MLE is required to respond to a channel change TL-SELECT indication is in the case of cell change in announced type 1 cell reselection. In this case the MLE shall respond with TL-SELECT response containing a parameter which gives the frequency of the main carrier on the new cell.

#### c) Outgoing messages from MM

These are generally routed via the attachment management sub-entity (see clause 18.3.4).

There are two exceptions to this.

The first is the MLE-IDENTITIES request primitive which contains the valid ISSI(s) and attached/detached GSSIs. The procedures for dealing with this are described in clause 18.3.5.1.

The second is the MLE-INFO request primitive which after the local recording of the subscriber class within the data transfer sub-entity is transferred further to the lower layers in a TL-CONFIGURE request primitive.

#### d) Incoming messages to MM

These are routed via the attachment management sub-entity (see clause 18.3.4).

#### e) Outgoing messages from SNDCP

On receipt of a MLE-CONFIGURE request primitive, the MLE shall pass on the information contained in its parameters to layer 2 using TL-CONFIGURE request.

#### f) Incoming messages to SNDCP

There are no messages routed from the TLC-SAP to SNDCP.

#### g) Outgoing messages from CMCE

On receipt of an MLE-CONFIGURE request primitive, MLE shall pass on the information contained in its parameters to layer 2 using TL-CONFIGURE request.

On receipt of an MLE-IDENTITIES request primitive, MLE shall pass on the information contained in its parameters to layer 2 using TL-CONFIGURE request.

#### h) Incoming messages to CMCE

There are no CMCE primitives received on the TLC-SAP.

### 18.3.5.4 Routing of local control information

On receipt of an MLE-OPEN request from the MM SAP, the data transfer sub-entity shall issue an MLE-OPEN indication to the CMCE and Sndcp SAPs. The data transfer sub-entity shall then open the SAPs and shall permit the transfer of data between layers. If the MLE-OPEN request is received whilst the data transfer sub-entity is in state closed then the data transfer sub-entity shall enter state all data. In all other states it shall remain in that state.

On receipt of an MLE-CLOSE request from the MM SAP the data transfer sub-entity shall relay this as an MLE-CLOSE indication to the CMCE and Sndcp SAPs. The data transfer sub-entity shall then close the SAPs and shall not permit the transfer of data between layers. The data transfer sub-entity shall enter state closed, and shall remain in that state until it receives an MLE-OPEN indication.

On receipt of an MLE-BREAK indication from the attachment management sub-entity, the data transfer sub-entity shall relay this MLE-BREAK indication to the CMCE and Sndcp SAPs. The data transfer sub-entity shall enter state broken. During a temporary link break data may be buffered in the data transfer sub-entity.

On receipt of an MLE-RESUME indication from the attachment management sub-entity, the data transfer sub-entity shall relay this MLE-RESUME indication to the CMCE and Sndcp SAPs. The data transfer sub-entity shall return to its previous state. Any data buffered in the data transfer sub-entity during the temporary link break should now be (re)submitted for transmission.

On receipt of an MLE-REOPEN indication from the attachment management sub-entity, the data transfer sub-entity shall relay this MLE-REOPEN indication to the CMCE SAP. The data transfer sub-entity shall enter state idle. Any data buffered in the data transfer sub-entity during the temporary link break should now be discarded.

On receipt of an MLE-BUSY request from the MM SAP, the data transfer sub-entity shall issue a MLE-BUSY indication to the CMCE and Sndcp SAPs.

On receipt of an MLE-IDLE request from the MM SAP, the data transfer sub-entity shall issue a MLE-IDLE indication to the CMCE and Sndcp SAPs.

On receipt of a TL-REPORT indication from LLC layer containing the reason "channel change", "transmission stopped", "reception stopped" the data transfer sub-entity shall relay it in an MLE-CONFIGURE indication to the entity which is using the radio resource as indicated by the endpoint identifier parameter.

NOTE: The channel change is also conveyed in MLE-DATA and MLE-UNITDATA indication primitives.

On receipt of a TL-RELEASE indication with "loss of radio resource" from lower layers the data transfer sub-entity shall relay it in an MLE-CONFIGURE indication into the service user(s) who is using this radio resource as indicated by the endpoint identifier parameter.

## 18.3.6 Network broadcast sub-entity

### 18.3.6.1 Summary

The system broadcast function broadcasts system information from the SwMI to all MSs.

There are two formats for this system information:

- immediate system information;
- network broadcast system information.

The immediate system information is supplied to layer 2 in the SwMI and broadcast on the BNCH and BSCH as defined in clause 9. The exact method by which the information is supplied to layer 2 is outside the scope of the present document. At the MS the MLE-PDU shall be received by the network broadcast sub-entity as TL-SYNC indication and TL-SYSINFO indication primitives via the TLB-SAP.

The network broadcast system information and late entry information is supplied to layer 2 in the SwMI and broadcast as requested. The exact method by which the information is supplied to layer 2 is outside the scope of the present document. At the MS the MLE-PDU shall be received by the network broadcast sub-entity as a D-NWRK-BROADCAST PDU with a TL-UNITDATA indication via the TLA-SAP and data transfer sub-entity. The MLE is able to route the network broadcast system information to the network broadcast sub-entity by virtue of the PDU header it arrives with, and the late entry information to CMCE-SAP by virtue of the PDU header it arrives with.



The SwMI shall indicate whether or not it supports transmission of the D-NWRK-BROADCAST PDU using the "neighbour cell broadcast" element which is transmitted as part of the D-MLE-SYNC PDU.

System broadcast information can be received whilst the MS is scanning or is camped on a cell. The MS-MLE shall ensure that system broadcast information received whilst scanning is applied to the correct cell.

An MS may also prompt the SwMI to transmit the neighbour cell broadcast information by using the neighbour cell enquiry service as described in clause 18.3.6.5.

### 18.3.6.2 System information

The system information is a series of messages that are broadcast at regular intervals from the SwMI to the MS MLEs.

The immediate system information contains the following information:

- MNC;
- MCC;
- LA Code (LAC);
- subscriber class;
- cell service level; and
- late entry information availability.

The network broadcast system information in the D-NWRK-BROADCAST PDUs contain a combination of the following information:

- frequencies of adjacent cells for cell selection and reselection;
- parameters for roaming (measurement levels, intervals).

This information should be used by the MSs to guide the cell selection procedures.

### 18.3.6.3 Message formats for system information

System information messages shall be constructed according to the rules described in clause 18.4. Each network broadcast system information may contain any combination of information elements.

### 18.3.6.4 Network broadcast procedures

On receiving a TL-SYNC indication primitive or a TL-SYSINFO indication primitive via the TLB-SAP, the network broadcast sub-entity shall analyse the contents. The information contained within shall either be passed to attachment management, e.g. to update cell rankings, and, in the case of a new subscriber class bit map, be passed to the data transfer sub-entity.

### 18.3.6.5 Neighbour cell enquiry procedure

An MS may prompt the SwMI to transmit the D-NWRK-BROADCAST PDU by sending a U-PREPARE PDU to the SwMI. The U-PREPARE PDU shall not contain an SDU. The U-PREPARE PDU shall contain the cell identifier element which shall be set to "00000<sub>2</sub>" and which shall indicate to the SwMI that the MS is requesting transmission of the D-NWRK-BROADCAST PDU.

**NOTE:** The MS may request transmission of the D-NWRK-BROADCAST PDU because it has yet not received the neighbour cell information and the MS needs this in order to initiate cell reselection procedures. This may occur if the current serving cell signal level is falling and the MS cannot wait for the normal D-NWRK-BROADCAST broadcast to be sent.

An MS may not receive the normal D-NWRK-BROADCAST broadcast, for example, as a result of being in energy economy and it is sleeping while the D-NWRK-BROADCAST is being transmitted by the SwMI.

MLE shall send the U-PREPARE PDU by issuing a TL-DATA request to layer 2 with the primitive parameters set as follows:

- PDU priority shall be set to 3;
- stealing permission shall be set to "steal immediately";
- the stealing repeats flag shall not be set.

MLE shall start timer, T370, and shall await the response from the SwMI. The SwMI shall respond by transmitting the D-NWRK-BROADCAST PDU which may be individually addressed to the MS using the layer 2 acknowledged service or may be sent unacknowledged to a group address or to the broadcast address ("all ones" address).

On reception of the D-NWRK-BROADCAST PDU, the MLE shall reset timer, T370. If timer, T370, expires the MS shall assume that the cell enquiry service has failed and shall wait for the SwMI to send the normal D-NWRK-BROADCAST broadcast. The SwMI may also respond to the U-PREPARE PDU with a D-PREPARE-FAIL PDU which has the "Fail cause" element set equal to "Neighbour cell enquiry not available".

The SwMI shall indicate whether or not the neighbour cell enquiry service is supported using the "neighbour cell broadcast" element which is transmitted as part of the D-MLE-SYNC PDU. If the service is not supported, the MS shall not attempt to send the U-PREPARE PDU with the cell identifier set to "00000<sub>2</sub>".

### 18.3.7 Management sub-entity

The management sub-entity shall be responsible for communication of management information between the MS and the SwMI. MLE PDUs to and from the management sub-entity shall have a protocol discriminator set to "110<sub>2</sub>". The PDUs shall be transferred between the MS and the SwMI using the TMI as the source address on the uplink and as the destination address on the downlink.

No TETRA management PDUs are defined in the present document.

## 18.4 PDU descriptions

The following PDU descriptions contain a mapping of the information elements into an MLE PDU specifying the length of the element, the type of the element and whether the element is mandatory, conditional or optional. The contents of the information elements themselves are further detailed in clause 18.5.

The information contained in the PDU description tables corresponds to the following key:

- Length: length of the element in bits;
- Type: element type 1 or 2 as defined below;
- C/O/M: conditional/optional/mandatory information in the PDU;
- Remark: comment.

### 18.4.1 Data transfer PDUs at the TLA-SAP

#### 18.4.1.1 Protocol discriminator

The contents of an MLE PDU sent and received at the TLA-SAP shall be determined by a 3 bit protocol discriminator. The discriminator shall be the first element field in the MLE PDU.

The protocol discriminator shall determine the MLE user SAP endpoint, i.e. it is used as routing information within the MLE data transfer sub-entity.

If the protocol discriminator indicates CMCE, MM, or SNDCP, then the MLE shall remove the protocol discriminator and route the SDU to the relevant upper layer 3 protocol entity.

If the protocol discriminator indicates TETRA management entity, then the MLE shall remove the protocol discriminator and route the SDU to the TETRA management functional entity within the MLE protocol entity.

If the protocol discriminator indicates MLE, then the MLE shall remove the protocol discriminator and process the remainder of the PDU according to the MLE protocol.

#### 18.4.1.2 PDU type

When the protocol discriminator indicates the MLE protocol, a "PDU type" element shall follow which shall indicate the particular MLE protocol PDU type.

#### 18.4.1.3 MLE service user PDUs

PDUs which have the protocol discriminator equal to one of the following: MM, SNDPCP, CMCE or TETRA Management Entity shall be defined as in table 220.

**Table 220: MLE service PDU layout**

Information element	Length	Value	Remark
Protocol discriminator	3		See clause 18.5.21 for element definition
SDU	Variable		MM, CMCE or Management Entity SDU

The SDUs sent/received at the LMM-SAP, LTPD-SAP, LCMC-SAP and to/from the management entity shall be transparent to the MLE. The MLE shall simply route these SDUs according to the protocol discriminator.

**Table 221: Void**

#### 18.4.1.4 MLE protocol PDUs

MLE PDUs which have the protocol discriminator MLE protocol shall comprise both cell change PDUs and network broadcast PDUs.

Refer to annex E for description of the general format of the MLE protocol PDU.

##### 18.4.1.4.1 D-NWRK-BROADCAST

- Message: D-NWRK-BROADCAST
- Response to: -/U-PREPARE
- Response expected: -
- Short description: Upon receipt from the SwMI, the message shall inform the MS-MLE about parameters for the serving cell and parameters for one or more neighbour cells.

**Table 222: D-NWRK-BROADCAST PDU**

Information element	Length	Type	C/O/M	Remark
PDU type	3	1	M	
Cell re-select parameters	16	1	M	
Cell service level	2	1	M	
TETRA network time	48	2	O	
Number of neighbour cells	3	2	O	see note 1
Neighbour cell information				see note 2
NOTE 1: If present, the element shall indicate how many "Neighbour cell information" elements follow. If not present, no neighbour cell information shall follow.				
NOTE 2: The element definition is contained in clause 18.5 which gives the type and length for each sub-element which is included in this element. The element shall be repeated as many times as indicated by the "Number of neighbour cells" element. There shall be no P-bit preceding each neighbour cell information element which is carried by this PDU.				

## 18.4.1.4.2 D-NEW-CELL

- Message: D-NEW-CELL
- Response to: U-PREPARE
- Response expected: -
- Short description: Upon receipt from the SwMI the message shall inform the MS-MLE that it can select a new cell as previously indicated in the U-PREPARE PDU.

Table 223: D-NEW-CELL PDU

Information element	Length	Type	C/O/M	Remark
PDU type	3	1	M	
Channel command valid	2	1	M	
SDU				see note
NOTE:	The SDU may carry an MM registration PDU which is used to forward register to a new cell during announced type 1 cell reselection or a D-OTAR CCK PROVIDE PDU which is used to identify the current CCK, it may also provide the future CCK for the LA which the MS has indicated in the U-OTAR CCK DEMAND and whether the CCK provided is in use in other LAs or is used throughout the SwMI. The SDU is coded according to the MM protocol description. There shall be no P-bit in the PDU coding preceding the SDU information element.			

## 18.4.1.4.3 D-PREPARE-FAIL

- Message: D-PREPARE-FAIL
- Response to: U-PREPARE
- Response expected: -
- Short description: Upon receipt from the SwMI the message shall be used by the MS-MLE as a preparation failure, while announcing cell reselection to the old cell.

Table 224: D-PREPARE-FAIL PDU

Information element	Length	Type	C/O/M	Remark
PDU type	3	1	M	
Fail cause	2	1	M	
SDU				see note
NOTE:	The SDU may carry an MM registration PDU. The SDU is coded according to the MM protocol description. There shall be no P-bit in the PDU coding preceding the SDU information element.			

## 18.4.1.4.4 D-RESTORE-ACK

- Message: D-RESTORE-ACK
- Response to: U-RESTORE
- Response expected: -
- Short description: Upon receipt from the SwMI, the message shall indicate to the MS-MLE an acknowledgement of the C-Plane restoration on the new selected cell.

**Table 225: D-RESTORE-ACK PDU**

Information element	Length	Type	C/O/M	Remark
PDU type	3	1	M	
SDU				see note
NOTE: This PDU shall carry a CMCE D-CALL RESTORE PDU which can be used to restore a call after cell reselection. The SDU is coded according to the CMCE protocol description. There shall be no P-bit in the PDU coding preceding the SDU information element.				

**18.4.1.4.5 D-RESTORE-FAIL**

- Message: D-RESTORE-FAIL
- Response to: U-RESTORE
- Response expected: -
- Short description: Upon receipt from the SwMI, the message shall indicate to the MS-MLE a failure in the restoration of the C-Plane on the new selected cell.

**Table 226: D-RESTORE-FAIL PDU**

Information element	Length	Type	C/O/M	Remark
PDU type	3	1	M	
Fail cause	2	1	M	

**18.4.1.4.6 U-PREPARE**

- Message: U-PREPARE
- Response to: -
- Response expected: D-NWRK-BROADCAST/D-PREPARE-FAIL
- Short description: The message shall be sent on the serving cell to the SwMI by the MS-MLE, when preparation of cell reselection to a neighbour cell is in progress.

**Table 227: U-PREPARE PDU**

Information element	Length	Type	C/O/M	Remark
PDU type	3	1	M	
Cell identifier	5	2	O	
SDU				see note
NOTE: The SDU may carry an MM registration PDU which is used to forward register to a new cell during announced type 1 cell reselection or a U-OTAR CCK DEMAND PDU which is used to request the Common Cipher Key (CCK) of the new cell. The SDU is coded according to the MM protocol description. There shall be no P-bit in the PDU coding preceding the SDU information element.				

**18.4.1.4.7 U-RESTORE**

- Message: U-RESTORE
- Response to: -
- Response expected: D-RESTORE-ACK/D-RESTORE-FAIL
- Short description: The message shall be sent by the MS-MLE, when restoration of the C-Plane towards a new cell is in progress.

**Table 228: U-RESTORE PDU**

Information element	Length	Type	C/O/M	Remark
PDU type	3	1	M	
MCC	10	2	O	see note 1
MNC	14	2	O	see note 1
LA	14	2	O	see note 1
SDU				see note 2
NOTE 1: The element is present in the PDU if its value on the new cell is different from that on the old cell.				
NOTE 2: This PDU shall carry a CMCE U-CALL RESTORE PDU which shall be used to restore a call after cell reselection. The SDU is coded according to the CMCE protocol. There shall be no P-bit in the PDU coding preceding the SDU information element.				

## 18.4.2 Broadcast PDUs at the TLB-SAP

PDUs at the TLB SAP shall be transported using the BNCH and BSCH logical channels. D-MLE-SYNC shall use the BSCH logical channel and D-MLE-SYSINFO shall use the BNCH logical channel.

### 18.4.2.1 D-MLE-SYNC

- Message: D-MLE-SYNC
- Response to: -
- Response expected: -
- Short description: This message shall inform the MS about information that is necessary for performing cell reselection. The message can only be recognised as a MAC to MAC message on the Broadcast Synchronization Channel (BSCH).

**Table 229: D-MLE-SYNC PDU**

Information element	Length	Type	C/O/M	Remark
MCC	10	1	M	
MNC	14	1	M	
Neighbour cell broadcast	2	1	M	
Cell service level	2	1	M	
Late entry information	1	1	M	

This PDU shall not contain an "O" bit and shall be 29 bits in length.

### 18.4.2.2 D-MLE-SYSINFO

- Message: D-MLE-SYSINFO
- Response to: -
- Response expected: -
- Short description: This message is used for informing the MS about MLE information for the serving cell. The message can only be recognised as a MAC to MAC message on the BNCH.

**Table 230: D-MLE-SYSINFO PDU**

Information element	Length	Type	C/O/M	Remark
LA	14	1	M	
Subscriber class	16	1	M	
BS service details	12	1	M	

This PDU shall not contain an "O" bit and shall be 42 bits in length.

## 18.5 Information elements coding

### 18.5.1 Cell reselection types supported

The element shall define which types of cell reselection are supported by the SwMI as defined in table 231.

**Table 231: Cell reselection types supported element**

Information element	Length	Value	Remark
Cell reselection types supported	2	00 <sub>2</sub>	Forward registration is not supported
		01 <sub>2</sub>	Forward registration is not supported
		10 <sub>2</sub>	Forward registration is supported
		11 <sub>2</sub>	Forward registration is supported

### 18.5.2 BS service details

The element shall contain information about which services are supported by the SwMI on a particular cell as defined in table 232.

**Table 232: BS Service details element**

Information element	Length	Value	Remark
Registration	1	0	Registration not required on this cell
		1	Registration mandatory on this cell
De-registration	1	0	De-registration not required on this cell
		1	De-registration mandatory on this cell
Priority cell	1	0	Cell is not a priority cell
		1	Cell is a priority cell
Minimum mode service	1	0	Cell may use minimum mode
		1	Cell never uses minimum mode
Migration	1	0	Migration is not supported by this cell
		1	Migration is supported by this cell
System wide services	1	0	System wide services temporarily not supported
		1	Normal mode
TETRA voice service	1	0	TETRA voice service is not supported on this cell
		1	TETRA voice service is supported on this cell
Circuit mode data service	1	0	Circuit mode data service is not supported on this cell
		1	Circuit mode data service is supported on this cell
Reserved	1	0	Default value
		1	Reserved for future expansion
SNDCPService	1	0	SNDCP service is not available on this cell
		1	SNDCP service is available on this cell
Air interface encryption service	1	0	Air interface encryption is not available on this cell
		1	Air interface encryption is available on this cell
Advanced link supported	1	0	Advanced link is not supported on this cell
		1	Advanced link is supported on this cell

### 18.5.3 Cell identifier

The element shall be used to identify a neighbour cell as defined in table 233. The serving cell shall attach a cell identifier to each neighbour cell whenever the serving cell broadcasts information about that neighbour cell. The cell identifier can then be used subsequently to refer to that neighbour cell. When the SwMI assigns a cell identifier, it shall then be able to map this identifier to a physical cell whenever the MS uses the cell identifier (for example, in a U-PREPARE PDU).

The cell identifier may also be set equal to "00000<sub>2</sub>" to initiate the neighbour cell enquiry procedure which prompts the SwMI to send the D-NWRK-BROADCAST PDU when the MS does not yet have the neighbour cell information.

**Table 233: Cell identifier element**

Information element	Length	Value	Remark
Cell identifier	5	00000 <sub>2</sub>	Neighbour cell enquiry
		00001 <sub>2</sub>	Valid cell identifier
		...etc.	...etc.
		11111 <sub>2</sub>	Valid cell identifier

### 18.5.4 Cell re-select parameters

The element shall define the threshold parameters for the cell reselection procedures in the MS as defined in table 234.

SLOW\_RESELECT\_THRESHOLD is the maximum level above the FAST\_RESELECT\_THRESHOLD for a radio improvable link i.e. SLOW\_RESELECT\_THRESHOLD = FAST\_RESELECT\_THRESHOLD + SLOW\_RESELECT\_THRESHOLD\_ABOVE\_FAST.

FAST\_RESELECT\_THRESHOLD is the maximum level above C1 = "0" for a radio relinquishable link.

SLOW\_RESELECT\_HYSTERESIS is the hysteresis for a radio improvable link.

FAST\_RESELECT\_HYSTERESIS is the hysteresis for a radio relinquishable link.

**Table 234: Cell re-select parameters element**

Information element	Length	Value	Remark
SLOW_RESELECT_THRESHOLD_ABOVE_FAST	4	0000 <sub>2</sub>	0 dB
		0001 <sub>2</sub>	2 dB
		...etc.	...etc.
		1111 <sub>2</sub>	30 dB
FAST_RESELECT_THRESHOLD	4	0000 <sub>2</sub>	0 dB
		0001 <sub>2</sub>	2 dB
		...etc.	...etc.
		1111 <sub>2</sub>	30 dB
SLOW_RESELECT_HYSTERESIS	4	0000 <sub>2</sub>	0 dB
		0001 <sub>2</sub>	2 dB
		...etc.	...etc.
		1111 <sub>2</sub>	30 dB
FAST_RESELECT_HYSTERESIS	4	0000 <sub>2</sub>	0 dB
		0001 <sub>2</sub>	2 dB
		...etc.	...etc.
		1111 <sub>2</sub>	30 dB

### 18.5.5 Cell service level

The element shall define the level of service a MS may receive in a cell as defined in table 235. It may relate to the traffic loading in a cell.



**Table 235: Cell service level element**

Information element	Length	Value	Remark
Cell service level	2	00 <sub>2</sub>	Cell load unknown
		01 <sub>2</sub>	Low cell load
		10 <sub>2</sub>	Medium cell load
		11 <sub>2</sub>	High cell load

### 18.5.6 Channel command valid

The element shall indicate to the MS MLE when to initiate a channel change as a result of cell reselection as defined in table 236.

**Table 236: Channel command valid element**

Information element	Length	Value	Remark
Channel command valid	2	00 <sub>2</sub>	Follow MAC channel change (follow channel allocation in MAC header)
		01 <sub>2</sub>	Change channel immediately
		10 <sub>2</sub>	No channel change - wait for next D-NEW CELL
		11 <sub>2</sub>	Reserved

### 18.5.7 Fail cause

The element shall indicate to the MS the failure cause as a result of requesting an MLE service in the SwMI as defined in table 237.

**Table 237: Fail cause element**

Information element	Length	Value	Remark
Fail cause	2	00 <sub>2</sub>	Neighbour cell enquiry not available (neighbouring cell enquiry); Temporary break in service (cell reselection);
		01 <sub>2</sub>	Cell reselection type not supported, perform registration and call restoration on the selected cell
		10 <sub>2</sub>	MS not allowed on cell
		11 <sub>2</sub>	Restoration cannot be done on cell

### 18.5.8 Late entry supported

The element shall indicate to the MS whether or not late entry can be supported by the cell as defined in table 238.

**Table 238: Late entry information element**

Information element	Length	Value	Remark
Late entry supported	1	0	Late entry not supported
		1	Late entry available

### 18.5.9 Location Area (LA)

The element shall define the LA in which a cell is located, either the serving cell or a neighbour cell as defined in table 239.

Table 239: LA element

Information element	Length	Value	Remark
LA	14		

### 18.5.10 Main carrier number

The element shall define the main carrier number for a neighbour cell as defined in table 240. See the channel allocation element in clause 21 and annex F for a full description of carrier numbering.

Table 240: Main carrier number element

Information element	Length	Value	Remark
Main carrier	12		Main carrier number of neighbour cell as defined in clause 21 and annex F

### 18.5.11 Main carrier number extension

The element shall define extended carrier numbering information as defined in table 241. See the channel allocation element in clause 21 and TS 100 392-15 [49] for a full description of carrier numbering.

Table 241: Main carrier number extension element

Information element	Length	Value	Remark
Frequency band	4		Provision for different frequency bands as defined in clause 21 and TS 100 392-15 [49]
Offset	2	00 <sub>2</sub>	No offset
		01 <sub>2</sub>	+6,25 kHz offset
		10 <sub>2</sub>	-6,25 kHz offset
		11 <sub>2</sub>	+12,5 kHz offset
Duplex spacing	3		Provision for different duplex spacing as defined in clause 21 and TS 100 392-15 [49]
Reverse operation	1	0	Normal
		1	Reverse

### 18.5.12 Minimum Rx access level

The element shall indicate the minimum received signal level required at the SwMI in a cell, either the serving cell or a neighbour cell as defined in table 242.

Table 242: Minimum Rx access level element

Information element	Length	Value	Remark
RXLEV_ACCESS_MIN_MCELL	4	0000 <sub>2</sub>	-125 dBm
		0001 <sub>2</sub>	-120 dBm
		...etc.	...etc.
		1111 <sub>2</sub>	-50 dBm (5 dB steps)

### 18.5.13 Maximum MS transmit power

The element shall indicate to the MS the maximum power that is allowed to be transmitted in a cell, either the serving cell or a neighbour cell as defined in table 243.

**Table 243: Maximum MS transmit power element**

Information element	Length	Value	Remark
MS_TXPWR_MAX_MCELL	3	000 <sub>2</sub>	Reserved
		001 <sub>2</sub>	15 dBm
		010 <sub>2</sub>	20 dBm
		011 <sub>2</sub>	25 dBm
		100 <sub>2</sub>	30 dBm
		101 <sub>2</sub>	35 dBm
		110 <sub>2</sub>	40 dBm
		111 <sub>2</sub>	45 dBm

### 18.5.14 MCC

The element shall indicate which country a cell is located in as defined in table 244. Refer to annex I for country code values.

**Table 244: MCC element**

Information element	Length	Value	Remark
MCC	10		

### 18.5.15 MNC

The element shall indicate which network a cell is located in as defined in table 245.

**Table 245: MNC element**

Information element	Length	Value	Remark
MNC	14		See EN 300 392-1 [9] clause 7.

### 18.5.16 Neighbour cell broadcast

The element shall indicate how an MS can obtain information about neighbour cells as defined in table 246. The neighbour cell information may be broadcast by the SwMI using the D-NWRK-BROADCAST PDU or the MS may use U-PREPARE to enquire for the D-NWRK-BROADCAST information.

**Table 246: Neighbour cell broadcast element**

Information element	Length	Value	Remark
D-NWRK-BROADCAST broadcast supported	1	0	Not supported
		1	Supported
D-NWRK-BROADCAST enquiry supported	1	0	Not supported
		1	Supported

## 18.5.17 Neighbour cell information

The element shall contain information about a neighbour cell as defined in table 247.

**Table 247: Neighbour cell information element**

Information element	Length	Type	C/O/M	Remark
Cell identifier	5	1	M	
Cell reselection types supported	2	1	M	
Neighbour cell synchronised	1	1	M	
Cell service level	2	1	M	
Main carrier number	12	1	M	
Main carrier number extension	10	2	O	see note 1
MCC	10	2	O	see note 2
MNC	14	2	O	see note 2
LA	14	2	O	see note 2
Maximum MS transmit power	3	2	O	see note 2
Minimum RX access level	4	2	O	see note 2
Subscriber class	16	2	O	see note 2
BS service details	12	2	O	see note 2
Timeshare cell and AI encryption information	5	2	O	see note 3
TDMA frame offset	6	2	O	see note 4
<p>NOTE 1: If not present, the "Main carrier number" element shall fully define the frequency of the neighbour cell main carrier. The neighbour cell extended carrier numbering information shall be assumed to be the same as that of the serving cell.</p> <p>NOTE 2: If not present, the neighbour cell parameter shall be assumed to be the same as that of the serving cell.</p> <p>NOTE 3: If not present, it shall be assumed that the neighbour cell is not operating in a discontinuous mode of operation and that the neighbour cell's AI encryption parameters are the same as that of the serving cell. If the element contains timeshare cell information, then AI encryption information shall not be changed in the MS. If the element contains AI encryption information, then timeshare cell information shall not be changed in the MS.</p> <p>NOTE 4: If present, the neighbour cell shall be synchronised to the serving cell and this element shall indicate the frame offset for the neighbour cell. If the cells are synchronised and this element is not present, it shall be assumed by the MS that the TDMA frame offset = 0.</p>				

For this element there shall be a P-bit for each type 2 element contained within.

## 18.5.18 Neighbour cell synchronised

The element shall indicate whether or not the neighbour cell is synchronised to the serving cell as defined in table 248.

**Table 248: Neighbour cell synchronised element**

Information element	Length	Value	Remark
Neighbour cell synchronised	1	0	Neighbour cell is not synchronised
		1	Neighbour cell is synchronised

### 18.5.19 Number of neighbour cells

The element shall indicate how many "Neighbour cell information" elements follow as defined in table 249.

**Table 249: Number of neighbour cells element**

Information element	Length	Value	Remark
Number of neighbour cells	3	000 <sub>2</sub>	No neighbour cell information available
		001 <sub>2</sub>	Number of "Neighbour cell information" elements contained in this PDU
		...etc.	...etc.
		111 <sub>2</sub>	Number of "Neighbour cell information" elements contained in this PDU

### 18.5.20 PDU type

The element shall indicate the PDU type for each of the MLE protocol PDUs. The PDU type shall have a separate definition for the uplink and downlink directions as shown in the table 250.

**Table 250: PDU type element**

Information element	Length	Value	Remark	
			DOWNLINK	UPLINK
PDU type	3	000 <sub>2</sub>	D-NEW CELL	U-PREPARE
		001 <sub>2</sub>	D-PREPARE FAIL	Reserved
		010 <sub>2</sub>	D-NWRK-BROADCAST	Reserved
		011 <sub>2</sub>	Reserved	Reserved
		100 <sub>2</sub>	D-RESTORE-ACK	U-RESTORE
		101 <sub>2</sub>	D-RESTORE-FAIL	Reserved
		110 <sub>2</sub>	Reserved	Reserved
		111 <sub>2</sub>	Reserved	Reserved

### 18.5.21 Protocol discriminator

The element shall indicate which protocol the PDU belongs to as defined in table 251. MM, CMCE and SNDCP PDUs are routed by the MLE to the relevant SAP. MLE protocol PDUs are processed by the MLE protocol entity and TETRA management entity PDUs by the TETRA management functional entity within the MLE.

**Table 251: Protocol discriminator element**

Information element	Length	Value	Remark
Protocol discriminator	3	000 <sub>2</sub>	Reserved
		001 <sub>2</sub>	MM protocol
		010 <sub>2</sub>	CMCE protocol
		011 <sub>2</sub>	Reserved
		100 <sub>2</sub>	SNDCP protocol
		101 <sub>2</sub>	MLE protocol
		110 <sub>2</sub>	TETRA management entity protocol
		111 <sub>2</sub>	Reserved for testing

## 18.5.22 Subscriber class

The subscriber class element shall be used by the SwMI to indicate which subscriber classes are allowed to use this cell as defined in table 252.

**Table 252: Subscriber class element**

Information element	Length	Value	Remark
Class 1	1	0	Subscriber class not allowed on cell
		1	Subscriber class allowed on cell
Class 2	1	0	Subscriber class not allowed on cell
		1	Subscriber class allowed on cell
Class 3	1	0	Subscriber class not allowed on cell
		1	Subscriber class allowed on cell
Class 4	1	0	Subscriber class not allowed on cell
		1	Subscriber class allowed on cell
Class 5	1	0	Subscriber class not allowed on cell
		1	Subscriber class allowed on cell
Class 6	1	0	Subscriber class not allowed on cell
		1	Subscriber class allowed on cell
Class 7	1	0	Subscriber class not allowed on cell
		1	Subscriber class allowed on cell
Class 8	1	0	Subscriber class not allowed on cell
		1	Subscriber class allowed on cell
Class 9	1	0	Subscriber class not allowed on cell
		1	Subscriber class allowed on cell
Class 10	1	0	Subscriber class not allowed on cell
		1	Subscriber class allowed on cell
Class 11	1	0	Subscriber class not allowed on cell
		1	Subscriber class allowed on cell
Class 12	1	0	Subscriber class not allowed on cell
		1	Subscriber class allowed on cell
Class 13	1	0	Subscriber class not allowed on cell
		1	Subscriber class allowed on cell
Class 14	1	0	Subscriber class not allowed on cell
		1	Subscriber class allowed on cell
Class 15	1	0	Subscriber class not allowed on cell
		1	Subscriber class allowed on cell
Class 16	1	0	Subscriber class not allowed on cell
		1	Subscriber class allowed on cell

## 18.5.23 TDMA frame offset

The element shall indicate the TDMA frame offset between the serving cell and a neighbour cell when both cells have synchronised carriers as defined in table 253. The element may be used for the time-shared mode of operation or to indicate the TDMA frame offset for synchronised cells operating in continuous mode.

**Table 253: TDMA frame offset element**

Information element	Length	Value	Remark
TDMA frame offset	6	000000 <sub>2</sub>	0 frame offset
		000001 <sub>2</sub>	1 frame offset
		...etc.	...etc.
		100011 <sub>2</sub>	35 frame offset
		100100 <sub>2</sub>	Reserved
		...etc.	...etc.
		111111 <sub>2</sub>	Reserved

If  $FN_n$  and  $FN_s$  denote the TDMA frame number of the neighbour cell and of the serving cell respectively, then:

$$FN_n = (FN_s - 1 + \text{TDMA frame offset}) \bmod 18 + 1; \quad (77)$$

where  $FN_n = 1 \dots 18$  and  $FN_s = 1 \dots 18$ .

## 18.5.24 TETRA network time

The element shall indicate the absolute TETRA network time to be used for time stamping as defined in table 254.

**Table 254: TETRA network time element**

Information element	Length	Value	Remark
Network time	24		see note 1
Local time offset sign	1		see note 2
Local time offset	6		see notes 2 and 3
Year	6		Note 4
Reserved	11		

NOTE 1: Zero time (000000<sub>16</sub>) is defined as 00:00 hours, Universal Time Co-ordinates (UTC time) on January 1st of every year.  
Each increment of this element above a value of zero shall correspond to a two second increment of the absolute network time.  
The values, F142FF<sub>16</sub> to FFFFFE<sub>16</sub>, are reserved.  
The value, FFFFFFF<sub>16</sub>, is reserved and shall be used to indicate an invalid value of time and timestamps in the event of network malfunction.

NOTE 2: The local time offset is coded as a signed integer containing information elements Local time offset sign and Local time offset. The value "0" shall indicate a positive offset and the value "1" shall indicate a negative offset. Zero offset shall be encoded with sign value "0".

NOTE 3: The Local time offset information element shall indicate the difference between the local time and the network time. The step size is 15 min, the maximum permissible offset shall be ±14 hours. The values 39<sub>16</sub> to 3E<sub>16</sub> are reserved. 3F<sub>16</sub> shall be used to indicate an invalid offset.

NOTE 4: Year is year since 2000 (e.g. year 2001 is encoded as 1). Maximum year value shall be 3E<sub>16</sub>. The value 3F<sub>16</sub> shall be used to indicate an invalid year.

NOTE 5: This field shall be set to all ones (7FF<sub>16</sub>).

## 18.5.25 Timeshare cell and AI encryption information

The Timeshare cell and AI encryption information element shall indicate the mode of discontinuous operation for a neighbour cell and the air-interface encryption as defined in table 255.

The "Discontinuous mode" field shall indicate which of the three types of discontinuous mode is in use.

If the discontinuous mode is "AI encryption" the usage of the bits comprising the "Reserved frames per two multiframes" sub-element shall be as defined in EN 300 392-7 [11].

If the mode is "MCCH sharing", the "Reserved frames" sub-element shall indicate how many frames are reserved for that neighbour cell.

If the mode is "Carrier sharing" or "Traffic carrier sharing" sharing, the "Reserved frames" sub-element shall be ignored by the MS.

Table 255: Timeshare cell information element

Information element	Length	Value	Remark
Discontinuous mode	2	00 <sub>2</sub>	AI encryption
		01 <sub>2</sub>	Carrier sharing
		10 <sub>2</sub>	MCCH sharing
		11 <sub>2</sub>	Traffic carrier sharing
Reserved frames per two multiframe (see note)	3	000 <sub>2</sub>	1 frame reserved
		001 <sub>2</sub>	2 frames reserved
		010 <sub>2</sub>	3 frames reserved
		011 <sub>2</sub>	4 frames reserved
		100 <sub>2</sub>	6 frames reserved
		101 <sub>2</sub>	9 frames reserved
		110 <sub>2</sub>	12 frames reserved
		111 <sub>2</sub>	18 frames reserved
NOTE:	If the discontinuous mode is "AI encryption" the information element name shall be as defined in EN 300 392-7 [11].		

## 18.6 Timers

### 18.6.1 Timer related actions

Timer related actions are defined in the protocols which use the timer.

### 18.6.2 Timer T370 - cell reselection preparation response time

This timer shall define the maximum time MLE shall wait for a response to U-PREPARE. The timer, T370, shall be of 5 s duration.

---

## 19 Layer 2 overview

### 19.1 Introduction

This clause gives an overview of the V+D air interface layer 2 (Data Link Layer (DLL)) which is further defined in the following four clauses. It does not imply any requirement for the testability of any of the functions described.

The descriptions in this clause do not imply a specific implementation, but are provided for the guidance of the reader in understanding the operation of layer 2.

### 19.2 Layer 2 architecture

The model of the DLL comprises two sub-layers: the LLC entity and the MAC entity. The basic functionality of these entities are as summarized in EN 300 392-1 [9], clause 6 and the services offered to the upper layer, the MLE, are explained in detail in clause 20. The error control schemes (FEC, CRC) are described in clause 8.

The following description applies to the protocol model of the DLL. The internal boundaries between the layers and sub-layers are not testable and do not imply any specific implementation, but are rather used for the description of the model. Throughout this clause the word "shall" is used for describing the SAPs for traceability reasons in the protocol model, but those SAPs are not testable.



## 19.2.1 Access to the DLL

Figure 75 shows the model of the DLL, its internal subdivision and its interaction with the upper layer (MLE) and lower layer (physical layer).

In the protocol model, the DLL shall provide services to the MLE through SAPs supporting different functions:

- TLA-SAP for all signalling messages;
- TLB-SAP for broadcasting system information; and
- TLC-SAP for layer management, status and configuration via data base access.

Internal communication between LLC and MAC shall use SAPs, namely TMA-SAP, TMB-SAP and TMC-SAP. They shall correspond to the separation between signalling, broadcast and layer management, as can be seen from the upper layer (MLE). Primitives and parameters are used for protocol description to exchange information at this internal boundary (LLC-MAC). The upper MAC layer shall contain MAC protocol functions (see clause 23).

There shall be a (virtual) SAP TMV-SAP inside the MAC layer to allow a protocol description using primitives and logical channels. The selection of a specific logical channel triggers specific channel coding at the lower MAC, which is devoted to the channel coding (see clause 8).

The SAP TP-SAP shall be used for communication between MAC and Physical Layer (PL). To exchange information at the TP-SAP, pre-formed subslots and blocks with burst type indication shall be used (see clause 9).

The TMD-SAP shall be used to support traffic in circuit mode. It shows clearly that no LLC functionality shall be expected in circuit mode. However, clause 19.4.3.2 describes how some traffic capacity may be stolen for signalling purposes in circuit mode.

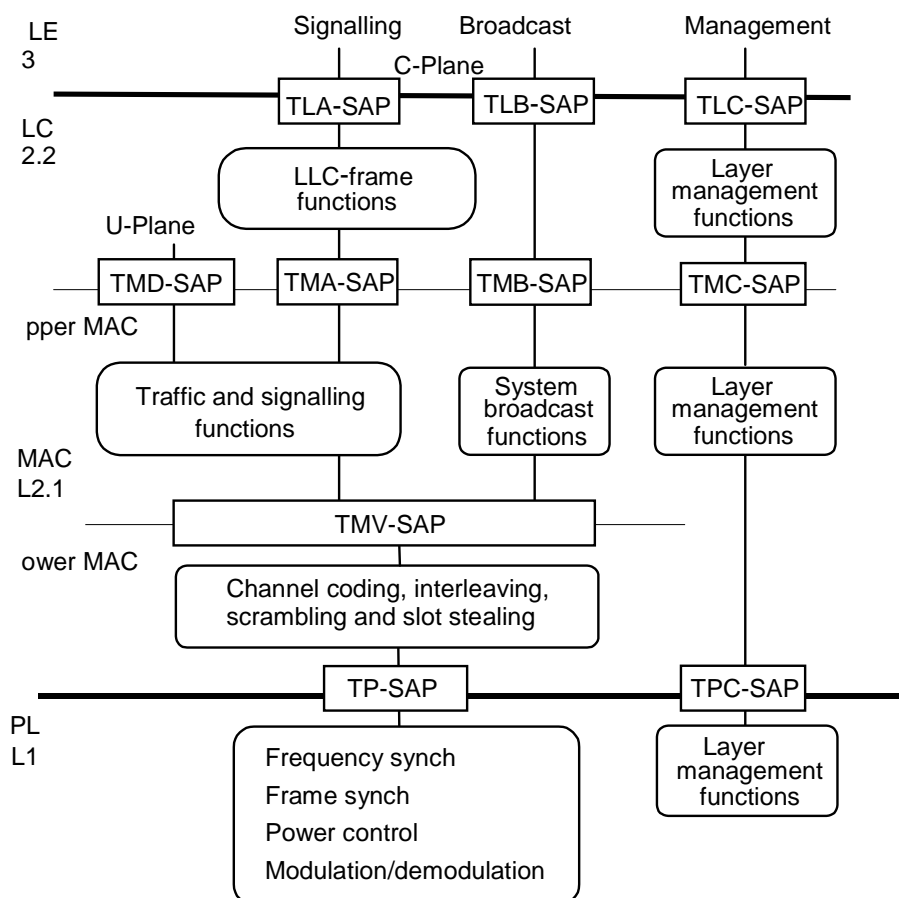


Figure 75: Layer 2 reference architecture

## 19.2.2 Information flow inside the DLL

The two types of communications links for TLA-SAP support on the DLL each have a specific quality of service. Before any communication establishment, one link shall exist whenever BS control channel monitoring is possible. This link is called the basic link and it offers a pre-defined quality of service which minimizes the LLC overhead over the air interface. A more powerful link may exist upon request. It is called the advanced link and it offers a more reliable and better service, especially for packet data transfer (see clause 22). When an advanced link is established, the basic link shall remain available. They may share the same timeslot in the multiframe structure.

Illustrations of the layer 2 functions applied to the information content present at the TLA-SAP are given on figures 76 and 77. On the left hand side, references to the relevant protocol layers are provided. The "other parameters" from the MLE may either be mapped into the LLC PDU or used by the DLL (e.g. priority).

The advanced link offers segmentation and error control using a Frame Check Sequence (FCS). The advanced link may be used for more reliable and efficient exchange of large amount of data as in, for example, packet data transfer.

It is mandatory for the MS to support the basic link, whereas it is optional for the MS to support the advanced link.

NOTE 1: The MAC scheme on figures 76 and 77 does not display the exact multiframe structure nor the random access procedure (see clause 23).

NOTE 2: The CRC is added only to the completed "MAC block" which may contain multiple TM-SDUs (MAC messages) on figure 76 and figure 77.

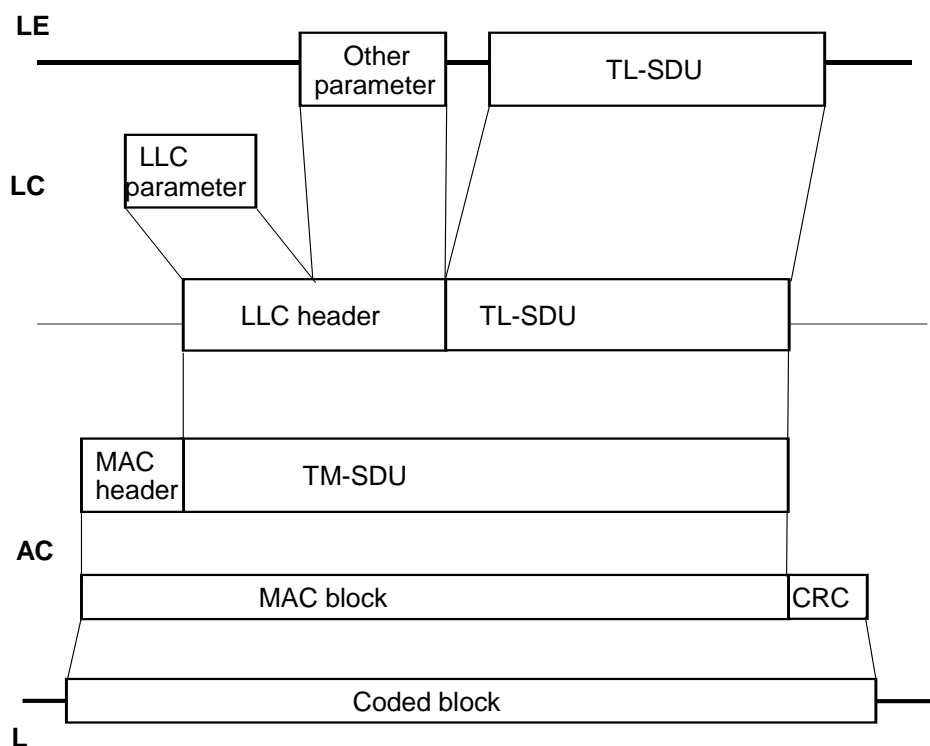


Figure 76: Layer 2 data structure for basic link (typically layer 3 signalling messages)

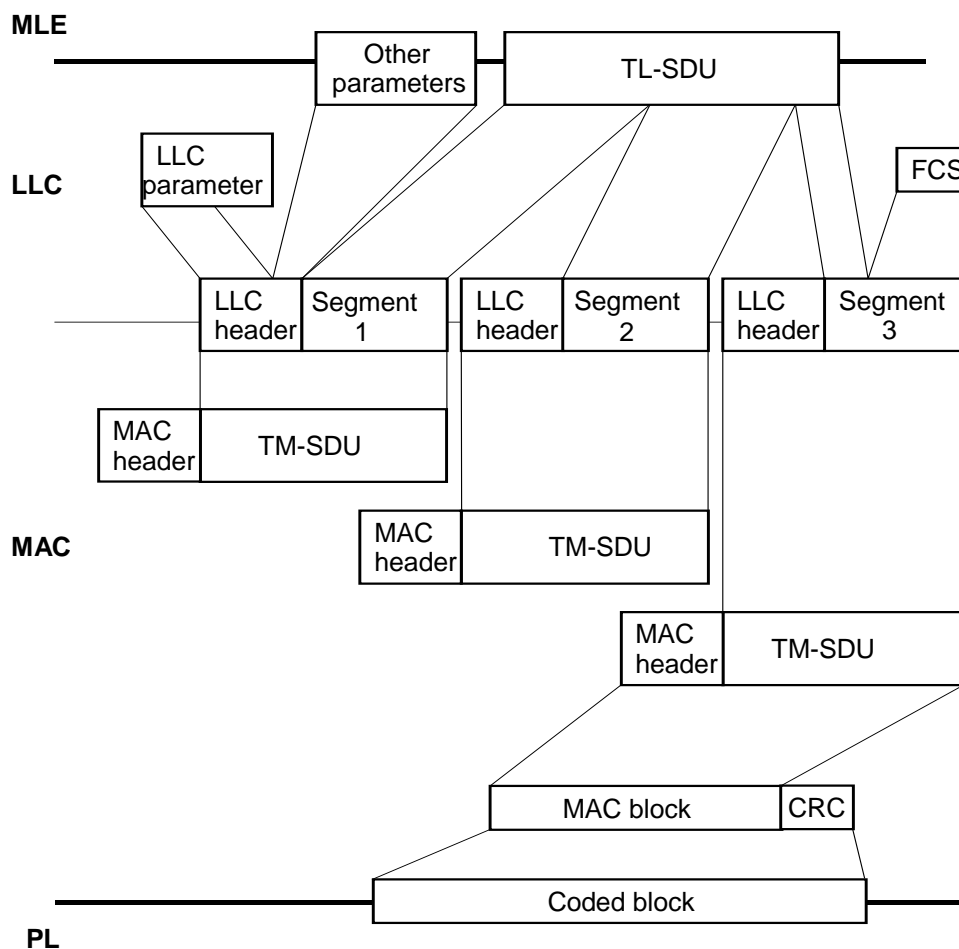


Figure 77: Layer 2 data structure for advanced link (e.g. packet data)

### 19.2.2.1 Basic link

The basic link should be used for general signalling messages (e.g. from CMCE or MM). The basic link offers the following services:

- acknowledged message transmission;
- unacknowledged message transmission;
- un-numbered fragmentation of longer messages;
- optional extended error control using an FCS (e.g. for long messages that require fragmentation).

The principal basic link data structure without fragmentation is shown in figure 76. The protocol is defined in detail in clauses 22 and 23.

### 19.2.2.2 Advanced link

An advanced link should be used if a larger amount of data is to be transferred (e.g. for packet data transmission) or if a better service is required. The service of an advanced link is negotiable at the set-up phase. The advanced link offers the following services:

- acknowledged message transmission;
- unacknowledged message transmission for point-to-multipoint transfer in the downlink;
- window mechanism;
- numbered segmentation of longer messages;
- selective re-transmission for point-to-point transfer;
- selective re-assembly for point-to-multipoint transfer;
- extended error control using a FCS.

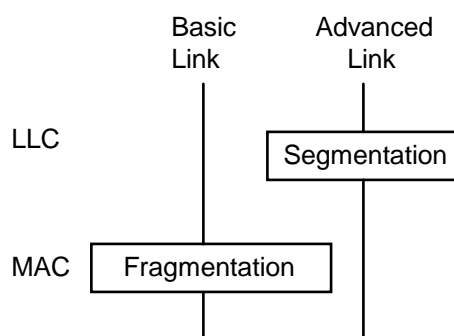
The advanced link data structure is shown in figure 77. The protocol is defined in detail in clauses 22 and 23.

### 19.2.2.3 Segmentation and fragmentation

There are two methods of sending a long TL-SDU defined in the present document: fragmentation and segmentation, which are defined in detail in clauses 23 and 22. Fragmentation may be performed in the MAC for a basic link while segmentation may be performed in the LLC for an advanced link (see figure 78).

Fragmentation shall be used for the basic link in case of an SDU exceeding the available capacity in the MAC (see figure 79). Fragments are not numbered so they shall be sent in sequence. No segmentation shall be performed by the LLC for the basic link.

For the advanced link, the LLC shall segment long data into segments (see figure 77). Each of them shall be individually recognizable by its LLC header. The segment length should match the MAC transmission unit (MAC block). As a segment is defined as the unit of re-transmission, fragmentation should not be used for advanced link messages.



**Figure 78: Segmentation and fragmentation in the DLL**

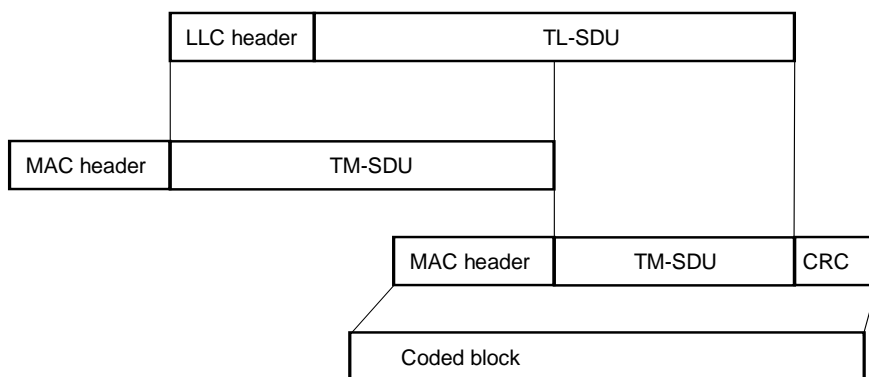


Figure 79: Fragmentation of long SDU in the MAC layer

### 19.2.3 Sub-layers

A detailed DLL illustration for peer-to-peer information exchange is presented in figure 80. The path followed by the information flow is shown from the C-plane SAPs - namely TLA and TLB. Information shall enter the MAC through the corresponding TMA and TMB SAP. The U-Plane information shall enter the MAC directly through the TMD-SAP. In either case, by using the TMV-SAP service primitive, the information shall then be placed into the appropriate logical channel and transmitted to the physical layer on the assigned timeslot in the multiframe.

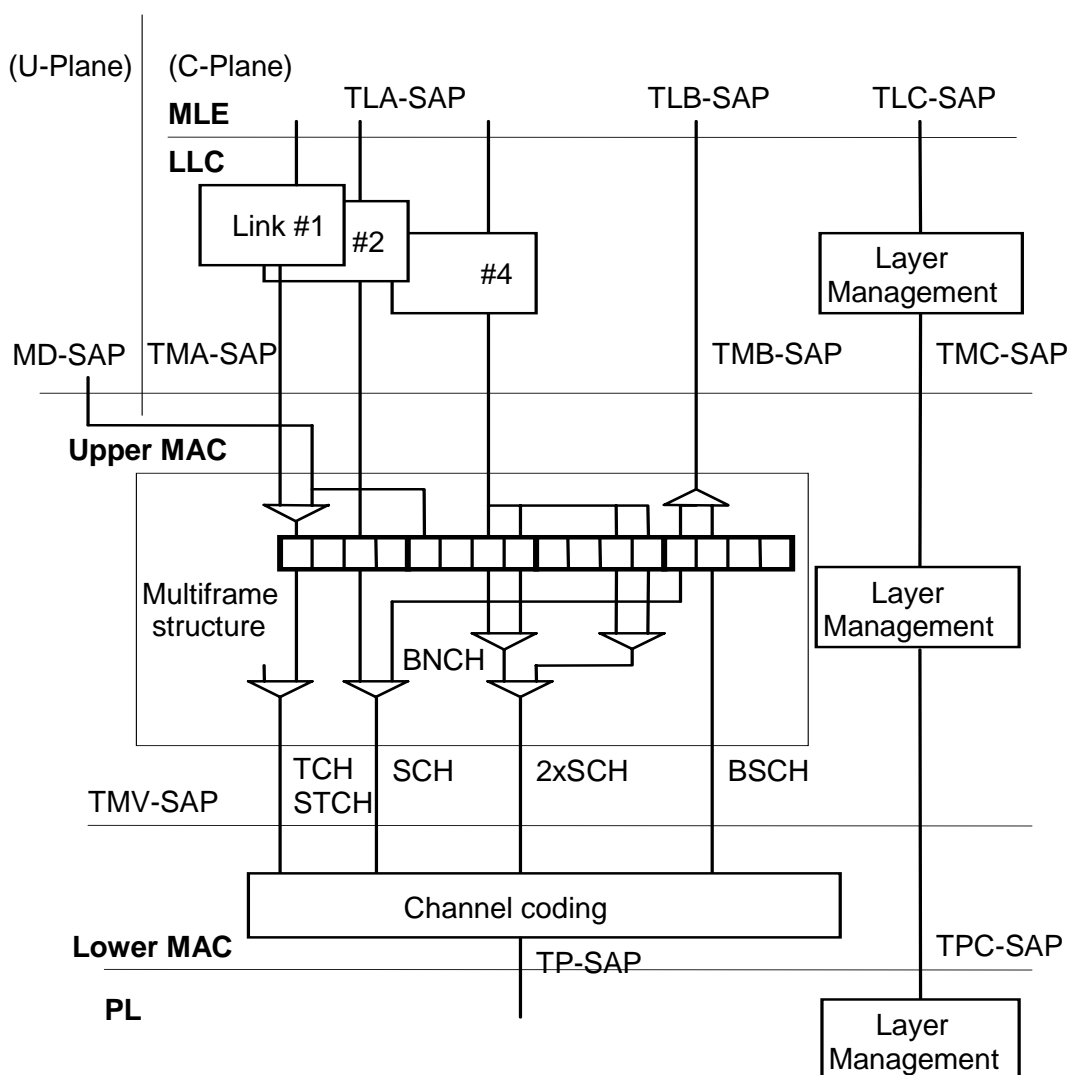


Figure 80: DLL protocol illustration for the MS side

The information for layer management flows through the TLC-SAP to the LLC and MAC and further down to the physical layer.

In figure 80 an example is shown in which some LLC links (numbered from 1 to 4) are set-up on the MS side.

NOTE: In the figure 60 three links are considered as a possible scenario, but it is not mandatory for an MS to support multiple links.

Link 1 uses the timeslot 1 in the multiframe structure in the upper MAC. Timeslot 1 is used for traffic coming from the TMD-SAP. The first occurrence of this traffic is stolen by link 1. Link 2 is used to send a signalling message in the uplink on timeslot 3 (in this example a set-up of an advanced link). After that message exchange, link 4 is the newly set-up advanced link using timeslots 3 and 4 to increase the throughput. Finally, some broadcast information are received under the TxB-SAP in timeslots 1 and 2 of the last shown frame.

The various logical channels involved in this communication exchange are shown at the TMV-SAP. At the lower MAC, a specific channel coding is applied for each of them. All information in the MAC not related to layer management shall be exchanged to/from the physical layer through the TP-SAP.

Each sub-layer should contain its own layer management.

### 19.2.3.1 LLC sub-layer

The LLC shall deal with the LLC link establishment and maintenance for the C-plane under the TLA-SAP. From the MLE point of view, there may be multiple LLC instances, each dealing with a specific quality of service and identified by a number corresponding to the end-point identifier, see figure 80. The basic link 1 shall be available when MS has synchronized to the BS. In addition to the basic link, the MLE may request a higher quality of service from the LLC, and the LLC then may set-up an advanced link or links as required depending on the capabilities of the physical layer of the MS. Each advanced link shall use a fixed resource at the MAC layer, which may be shared by a basic link.

The number of simultaneous links in an MS depends on its capability to use multiple timeslots in a frame. Up to 4 independent advanced links may be set-up in a frame. Then, up to 4 basic links may be associated with the corresponding advanced links. (Scanning a different frequency or cell in search for a control channel uses a different link).

Under the TLB-SAP, there is no LLC functionality and the MLE SDU is passed directly to/from the TMB-SAP. Therefore, peer-to-peer information exchange between LLC entities does not exist and there exists no LLC PDU for the broadcast under the TLB-SAP.

The TLC-SAP shall be used for layer management and layer-to-layer control communication.

### 19.2.3.2 MAC sub-layer

The main functionalities of the MAC are channel access control, radio resource control, data transfer and error detection. Encryption over the air interface shall be performed in the upper MAC when required.

The LLC links defined at the TLA-SAP shall enter into the MAC using the TMA-SAP. Logical channel allocation and multiplexing shall be performed internally by the MAC. From the protocol point of view, the upper MAC shall communicate with the lower MAC by means of primitives through logical channels. From the architecture point of view, the choice of the logical channels permits selecting among different means of data protection (channel coding) which are part of the lower MAC. But as far as the upper MAC protocol is concerned, this lower level functionality has no impact on the content of the message.

After the set-up of a circuit mode speech or data call, signalling messages may use the ACCH or may use the traffic channel stealing mechanism (Stealing Channel STCH).

Figure 80 illustrates how signalling from the LLC link 1 shares a timeslot with user traffic from U-plane by stealing and using the STCH logical channel. The user plane traffic uses the TCH logical channel. The broadcast information flowing via TMB-SAP may use specific BSCH logical channel or signalling logical channel SCH. The MAC layer allocates 2 timeslots ( $2 \times \text{SCH}$ ) for the LLC instance 4 using an advanced link providing a higher transfer rate. All logical channels are then encoded at the lower MAC layer as defined by the logical channel (refer to clause 8).

## 19.2.4 Logical channels

### 19.2.4.1 Logical channels at the LLC-SAP

The MLE communicates to the LLC by using the relevant SAPs. Multiple LLC instances may be seen through the TLA-SAP. The MLE may choose to send a request on any available link, taking into account the associated quality of service.

### 19.2.4.2 Logical channels at the MAC-SAP

The LLC and U-plane shall communicate with the MAC via the relevant SAPs. The TMA-SAP shall be used for signalling, the TMB-SAP shall be used for downlink broadcast, the TMC-SAP shall be used for layer management and the TMD-SAP shall be used for circuit mode traffic and user signalling.

### 19.2.4.3 MAC internal logical channels

The logical channels may be separated into two categories:

- 1) traffic channels carrying U-plane information (circuit mode data and voice) plus end-to-end user signalling information. These shall carry information which is exchanged via the TMD-SAP at the MAC boundary;
- 2) control channels carrying C-plane information (control messages and packet data). These shall carry information which is exchanged via the TMA- and TMB-SAP at the boundary between MAC and LLC.

The following logical channels are defined within the upper MAC:

- Control Channel comprising:
  - Main Control Channel (MCCH);
  - Common Secondary Control Channel (Common SCCH);
  - Assigned Secondary Control Channel (Assigned SCCH).

These channels shall carry control information appearing at the TMA-SAP addressed to MS not involved in a circuit mode call. Refer to clause 23.

- Associated Control Channel (ACCH) comprising:
  - Fast Associated Control Channel (FACCH);
  - Stealing Channel (STCH);
  - (Slow) Associated Control Channel ((S)ACCH).

These channels shall carry control information appearing at the TMA-SAP intended for MS involved in a circuit mode call.

- Broadcast Common Control Channel (BCCH) comprising:
  - Broadcast Synchronization Channel (BSCH);
  - Broadcast Network Channel (BNCH).

These channels shall carry the system broadcast information appearing at the TMB-SAP.

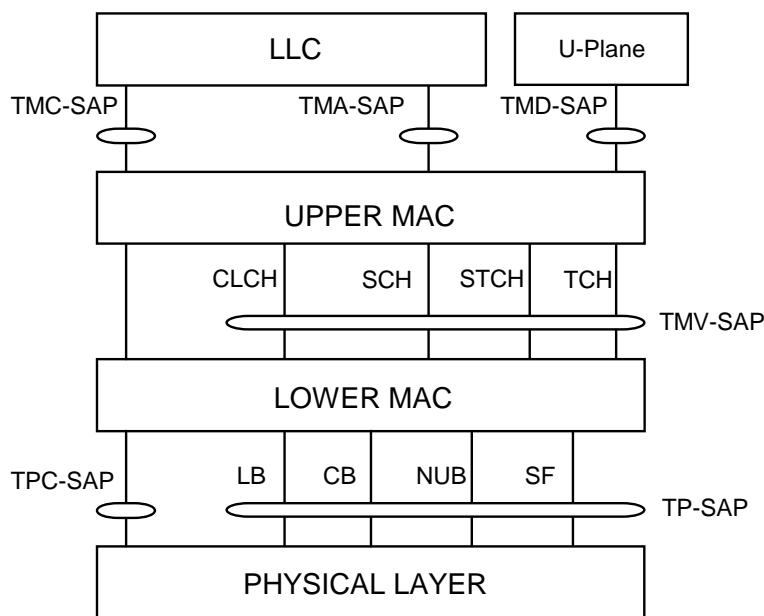
#### 19.2.4.4 Logical channels at the lower MAC

Logical channels shall offer different physical paths to the information depending on the chosen error control scheme among those defined in clause 8.

The following generic logical channels shall be available at the lower MAC boundary (see figures 81 and 82):

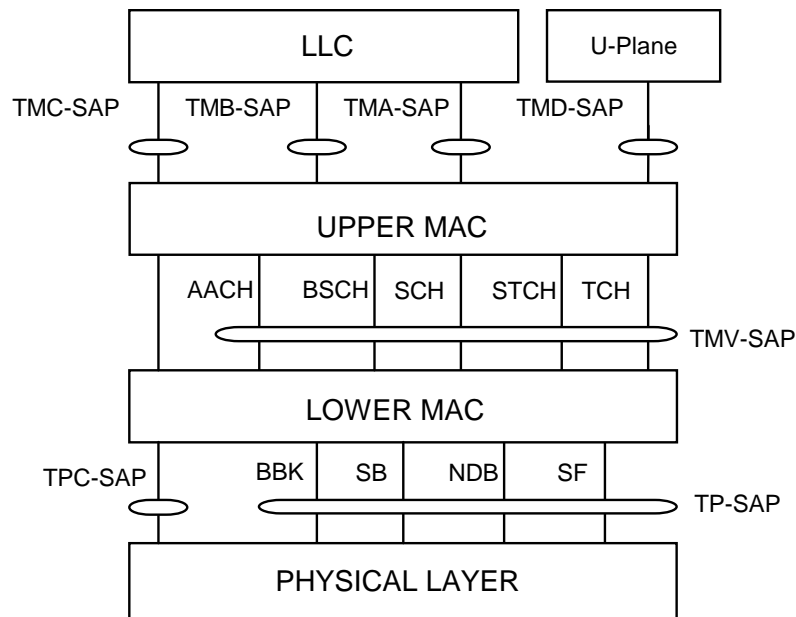
- Access Assignment Channel (AACH);
- Broadcast Synchronization Channel (BSCH);
- Signalling Channel (SCH);
- Traffic Channel (TCH);
- Stealing Channel (STCH);
- Common Linearization Channel (CLCH).

As far as possible, the present document avoids defining specific physical architectures, but proposes instead to explain operation of the MAC sub-layer in terms of the functional blocks and logical channels. This reference model architecture applies equally to MSs and BSs. MSs transmission and reception are shown in figures 81 and 82 respectively.



**Figure 81: MAC sub-layers and logical channels for MS uplink transmission**





**Figure 82: MAC sub-layers and logical channels for MS downlink reception**

Tables 256 and 257 provide a summary of the logical channels shown in the previous figures. The information mapping on these logical channels is presented starting with the MAC layer SAPs down to the physical bursts and blocks.

**Table 256: Mapping between TMx-SAP and MAC logical channels**

SAP	Definition	Logical channel in TMV-SAP	Definition
TMA	main or secondary control channel	SCH/F SCH/HD SCH/HU	signalling channel (full slot) signalling channel (1/2 slot downlink) signalling channel (1/2 slot uplink)
	fast associated control channel slow associated control channel	SCH/F SCH/HD SCH/HU	signalling channel (full slot) signalling channel (1/2 slot downlink) signalling channel (1/2 slot uplink)
	stealing channel (signalling)	STCH	stealing channel (signalling)
TMD	traffic channel (circuit mode)	TCH	traffic channel (circuit mode)
	stealing channel (user signalling)	STCH	stealing channel (user signalling)
TMB	broadcast synchronization channel	BSCH	broadcast synchronization channel
	broadcast network channel	BNCH on SCH/HD	signalling channel (1/2 slot downlink)
-	access assignment channel (generated inside the upper MAC)	AACH	access assignment channel
-	common linearization channel (generated inside the upper MAC)	CLCH	common linearization channel

**Table 257: Mapping between MAC logical channels and physical layer bursts**

Logical channel in TMV-SAP	Definition	Physical burst	Definition
SCH/F	full slot signalling channel	NDB, NUB	normal downlink burst, normal uplink burst
SCH/HD	half slot downlink signalling channel	NDB + SF BKN2 of SB	normal downlink burst and slot flag 2nd half of synchronization burst
SCH/HU	half slot uplink signalling channel	CB	control uplink burst
STCH	stealing channel	NDB + SF, NUB + SF	normal downlink burst and slot flag, normal uplink burst and slot flag
TCH	traffic channel	NDB, NUB	normal downlink burst, normal uplink burst
BSCH	broadcast synchronization channel	SB	synchronization burst
AACH	access assignment channel	BBK	broadcast block
CLCH	common linearization channel	LB	linearization burst

### 19.2.5 Lower layer management at the DLL

The TETRA protocol architecture, EN 300 392-1 [9], clause 6 shows how the lower layer management entity is incorporated into all lower layers and is accessible via SAPs TXC-SAP as shown in figures 75 and 80 for the lowest layers. Those access points enable access to information such as measured values, status, general information. The services related to the management of LLC and MAC are described in clause 20.

The DLL should have its own set of functions and measured values. These parameters shall be exchanged using a set of primitives as described in the appropriate clause, namely clauses 23 and 22.

## 19.3 System modes of operation

This clause provides an outline description of system modes of operation and their impact on layer 2.

### 19.3.1 Normal mode

In the normal mode of operation, the common control channel on the main carrier shall always be the MCCH and shall always be present in timeslot 1 of all frames 1 to 18. This common control channel shall be used for all common control signalling. All MSs shall be able to locate and listen to the downlink transmissions of the MCCH. The BS shall transmit on all downlink slots of the main carrier during normal mode.

### 19.3.2 Extended mode

A BS may have more than one control channel (common or assigned) operational at a time. The ways to operate this may be as follows:

- in addition to MCCH, BS may have from one to three common SCCH, which has the same functionality as the MCCH but may be used only by a sub-set of the user population;
- in addition to MCCH, BS may have one or several assigned SCCHs used to continue control signalling and packet mode signalling after the initial random access or paging message;
- in minimum mode (without MCCH), BS may have one or several assigned SCCHs used to continue control and packet mode signalling after the initial random access or paging message;
- in addition to MCCH, BS may have from one to three common SCCH and one or several assigned SCCHs used to continue control and packet mode signalling after the initial random access or paging message.

The MCCH and common SCCHs cannot be extended to more than one timeslot per TDMA frame.

Assigned SCCH can be from one up to four timeslots per TDMA frame.

Common SCCHs shall be in the same carrier as the MCCH. Assigned SCCHs may be allocated from any carrier.

NOTE: The extended mode does not necessarily increase the control channel capacity of an individual MS, only a multislot assigned SCCH provides a higher transfer rate.

### 19.3.3 Minimum mode

Minimum mode allows a BS to assign all four timeslots on the main carrier for traffic or dedicated control purpose. In this mode, only frame 18 can be used for common control without disturbing the established services. A BS enters minimum mode when all four downlink timeslots on the main carrier are assigned so that there is no common control channel available in timeslot 1.

### 19.3.4 Discontinuous transmission mode

A BS may transmit discontinuously on the main carrier when it operates in one of the following time sharing modes.

### 19.3.5 Time sharing mode

In the time shared mode, multiple BSs may use the same radio resource for control channel purposes in a co-ordinated manner.

#### 19.3.5.1 Carrier sharing mode

In carrier sharing mode, one carrier frequency shall be shared among up to four cells, each cell being allocated at least one timeslot of the TDMA frame (see clause 9 for more details).

#### 19.3.5.2 MCCH sharing mode

In the MCCH sharing mode, the MCCH shall be shared among several cells in a manner under the control of the infrastructure (see clause 9 for more details).

## 19.4 MS modes of operation

### 19.4.1 Idle mode

The idle mode shall be the state of the registered MS not involved in any particular transmission. It shall consist of listening to the MCCH or to any signalling channel the MS could have been told by the SwMI. The MS shall be capable of monitoring adjacent cell in this mode as described in clause 23.

### 19.4.2 Signalling and packet mode

#### 19.4.2.1 Common control channel

This channel shall support common signalling for all MSs (see clause 23). In a system, there may be in addition to the MCCH one or more SCCHs. By default, the MS shall listen to the MCCH for paging and other signalling (see clause 19.4.5 for energy economy).

#### 19.4.2.2 Secondary control channels

These channels shall be used to increase the capacity of the common control channel. They may have the same functionality as the MCCH for a subdivision of the population or they may be devoted to support only certain type of transmission, e.g. packet mode data. In that respect, they may serve as a control channel dedicated to packet data transmission (see clause 23). The BS shall command MS to use appropriate control channel by allocating additional resources or by commanding MS to go to a certain control channel (refer to clause 19.3.2). The BS shall command MS to use the appropriate control channel, either by a broadcast message indicating the number and location of common SCCHs in operation, or by commanding certain MS to go to an ASCCH.

NOTE: A BS could use an assigned SCCH for continuing signalling for circuit mode call set-up. The BS may decide to assign an SCCH for advanced link packet data transmission. There are different possible methods of usage.

EXAMPLE: a) the BS may use an assigned SCCH for only one advanced link (i.e. similar to the usage of a channel for a circuit mode call); or

b) the BS may use an assigned SCCH as a general packet data channel, supporting advanced links for many MSs, where each MS may be offering/receiving data packets at a low rate or intermittently.

MS operation is the same in both cases. The channel usage is scheduled by the BS; and MSs transmit only under BS control (by random access or reserved access). An MS remains on the channel while its advanced link is connected, even though the MS is not necessarily using the link all the time. After a pause, the MS uses random access when it wishes to continue transmission.

An advanced link can also use a common control channel or, for MSs in a circuit mode call, an ACCH. However, if common control channel, the normal control channel performance may be degraded.

### 19.4.2.3 Associated Control Channel (ACCH)

This channel shall be used for signalling in conjunction with an established circuit (traffic channel). That signalling may be independent of the call the control channel is associated with. The lower MAC should be configured as shown in figure 83. Depending on the circuit mode call type and the capabilities of MS, the ACCH may be available during timeslots in frames 1 to 18 (if they are not being used for traffic), and it is always available during the 18th frame; refer to clause 23. The first one is called Fast Associated Control Channel (FACCH) (frames 1 to 18) and the latter Slow Associated Control Channel (SACCH) (frame 18). The MS shall listen to the ACCH under control of the BS; refer to clause 19.4.4.

### 19.4.2.4 Full and half slot signalling

In figure 83 and figure 84, full ( $SF = 0$ ) or half slot ( $SF = 1$ ) downlink signalling shall be indicated by the appropriate slot flag (SF). The slot flag (SF) shall be a change between two training sequences, as described in clause 9. Downlink control messages may usually occupy a full slot, but the system Broadcast channels (BxCH) shall be all one half slot long to enable them to be transmitted in frame 18 (BSCH or SCH/HD; see clause 9).

For the MS transmission on the uplink, use of a subslot for initial access shall be indicated by a third training sequence corresponding to the logical channel SCH/HU as described in clause 9.

Uplink control messages are usually sent within a subslot using the logical channel SCH/HU. However, for packet data or when using fragmentation, the MS may need to use full slots for the transmissions subsequent to the initial access. The allocation of MS uplink timeslots shall be under the control of BS.

Once the MS has switched into traffic mode, all transmissions shall be done over an entire timeslot. Distinction between full slot for traffic and half slot to indicate that the first half slot has been stolen for signalling purposes shall be indicated by a change between the two training sequence, in a manner identical to that used for the downlink.

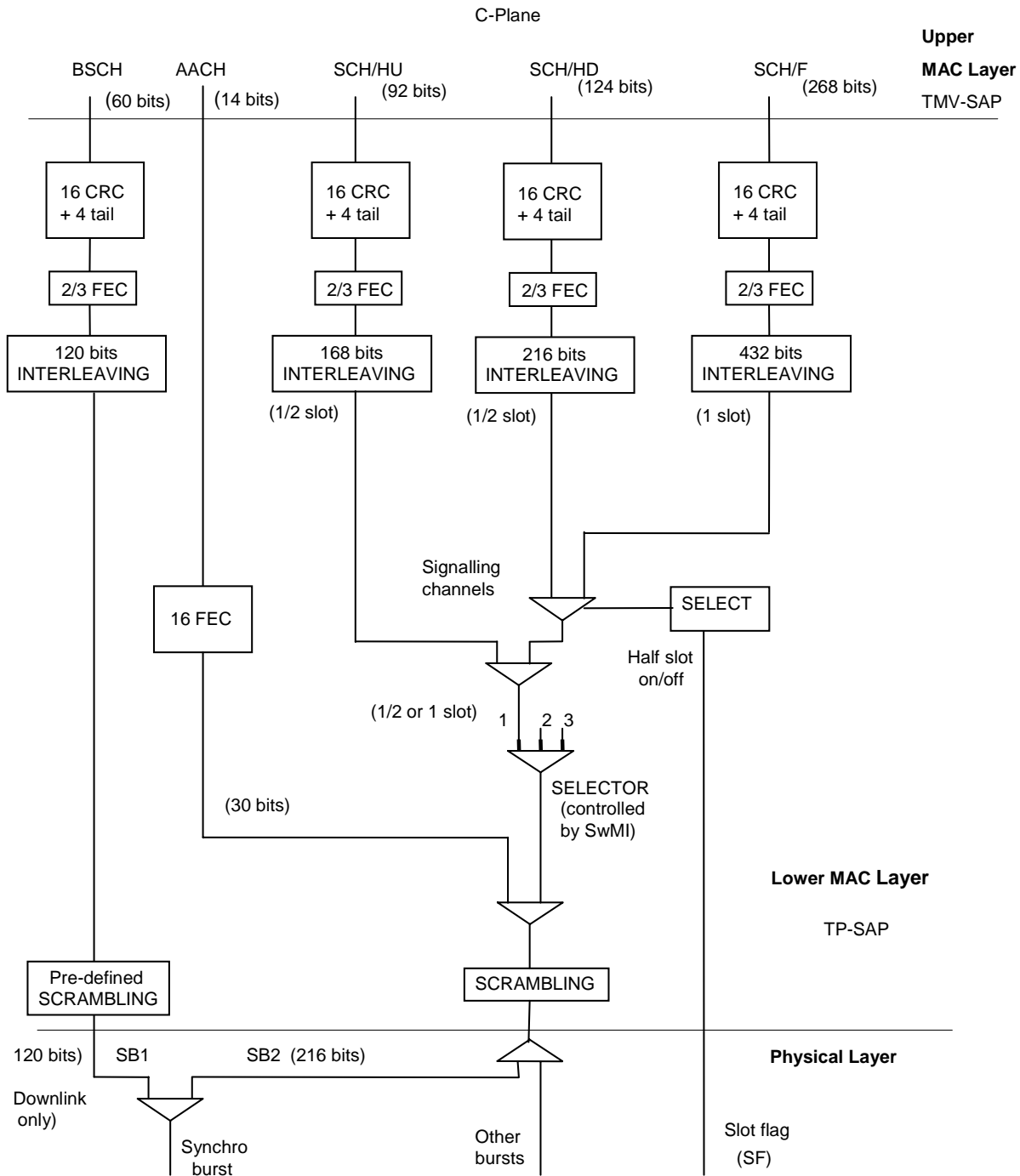


Figure 83: Configuration in signalling and packet mode

## 19.4.3 Traffic mode

### 19.4.3.1 Normal operation

The traffic mode may be either speech or data circuit operation. The logical channels in use shall be TCH (traffic channels) for frames 1 to 17. Full slots (Slot Flag = 0) shall normally be used for traffic. Frame 18 shall be used for signalling only.

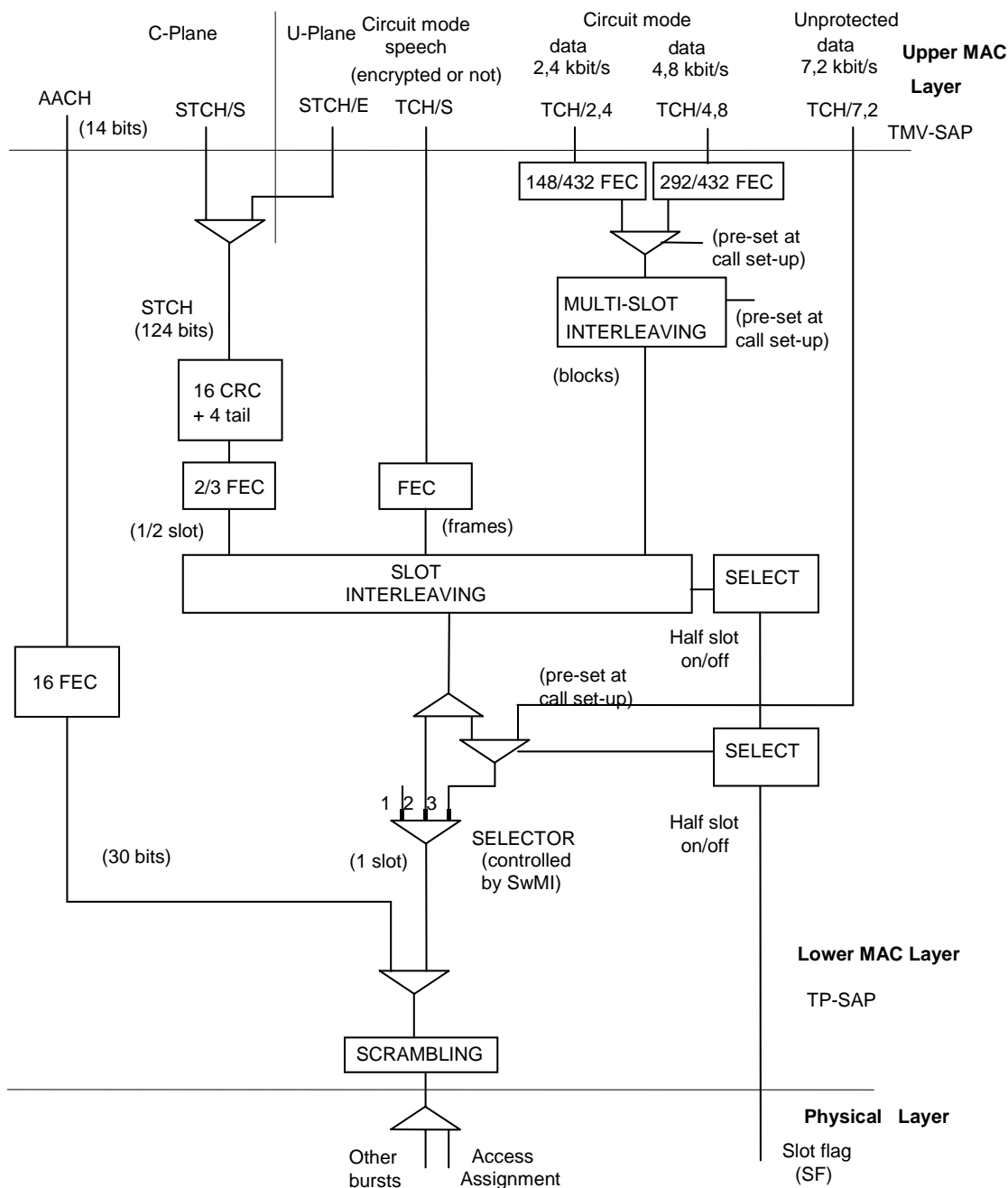


Figure 84: Configuration in traffic mode for frames 1 to 17

### 19.4.3.2 Stealing mechanism

When in traffic mode (either speech or data circuit), capacity may be stolen for signalling purposes. This shall leave the current mode of operation unchanged. The appearance of half slot ( $SF = 1$ ) in the transmission shall indicate that stealing has occurred. Half slot ( $SF = 1$ ) operation shall be indicated by a change in the appropriate training sequence as described in clause 9. The header of the first half of the slot shall indicate whether the other half has also been stolen or if it belongs to the normal traffic circuit. The header shall contain an information on the intended destination of the signalling message: either C-plane or U-plane signalling. Stealing occurrence shall be locally reported to the U-plane application at the TMD-SAP (see figure 84).

This mechanism shall apply to both BS and MS transmissions.

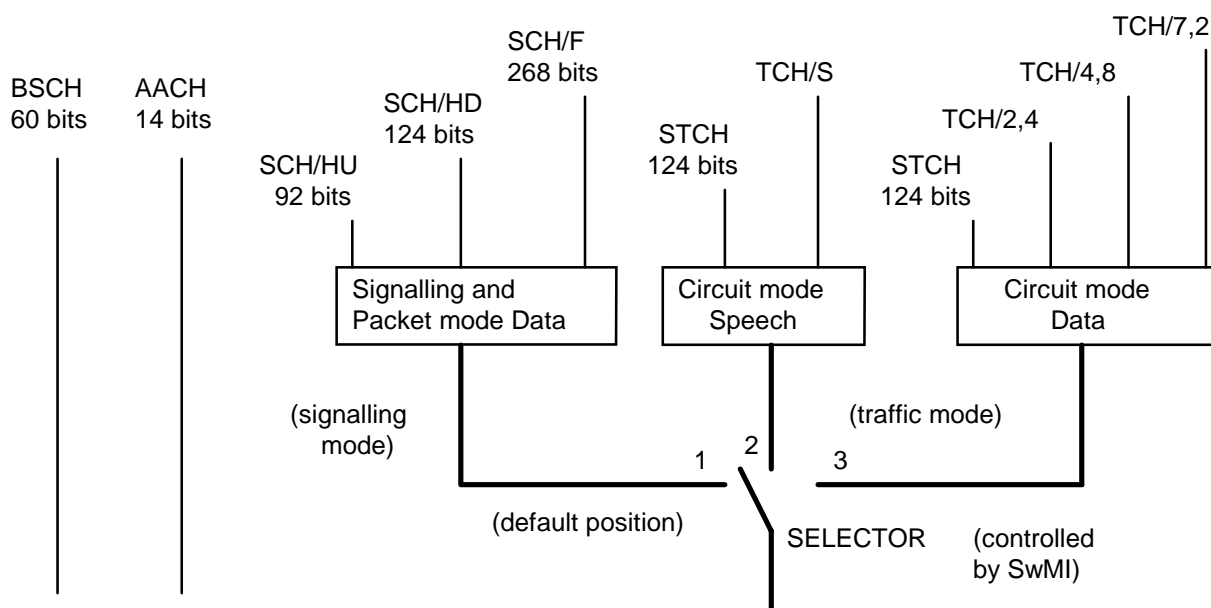
### 19.4.4 Selection of the mode of operation

During a transaction, the MAC shall be considered to be switched into one of the following modes of operation:

- signalling mode; or
- traffic mode.

The selection mechanism is presented in figure 85. The default mode of the MAC layer shall be signalling mode (selector in position 1 on figure 85). The BS shall send CC messages to change the mode of operation in the MS MAC layer. This change shall be reflected from the CC into the MAC using layer management communication internal to the MS. In case of accidental loss of the CC message, a fall-back mechanism is specified using the AACH indications.

When stealing is initiated in circuit mode operation (either by the MS or the SwMI), the logical channel shall be temporarily taken (fully or partially) on a half slot by half slot basis for signalling purposes.



**Figure 85: Selection of the configuration for the current mode of operation**

If traffic mode is selected, then the mode selector switch shall be considered to be set accordingly in the MS and in the SwMI.

In case of independent uplink and downlink assignment (e.g. to cover inter-site calls), the selector may be duplicated for uplink and downlink operation (i.e. for MS transmission and reception). Still, the selectors shall be set accordingly in the MS and SwMI.

NOTE: Traffic mode applies only to frames 1 to 17. Both MS and BS are in signalling mode on frame 18.

### 19.4.5 Energy economy mode

On the MS request, the BS MM may command the MS to energy economy mode. The start of the energy economy shall be indicated by the BS. The MS shall then follow a regular cycle of N timeslots in energy economy for 1 timeslot in reception. During energy economy mode, the MS shall remain synchronized to the BS transmission.

### 19.4.6 Support of concurrent calls

Depending on the class of the mobile, concurrent calls may be supported by LLC (see clause 22) and MAC (see clause 23) protocols.

### 19.4.7 Support of air-interface encryption

The support of encryption is optional and shall be indicated as part of the MS capabilities (i.e. in the class of MS).

If this mode is supported, the MAC shall encrypt signalling messages as instructed by the upper layers on a message basis. Encrypted messages shall be indicated in the MAC header in order to enable the receiving end to de-encrypt the message content.

The MAC may in addition encrypt the content of the half slots coming from the TMD-SAP. This may also apply to an established encrypted call. The encrypted speech shall then be encrypted once more in the MAC. In this case, encryption synchronization messages shall also be encrypted at the MAC level and decrypted before being passed through the TMD-SAP at the receiving side.

## 19.5 Scenarios for primitives and PDU transfer on the air interface

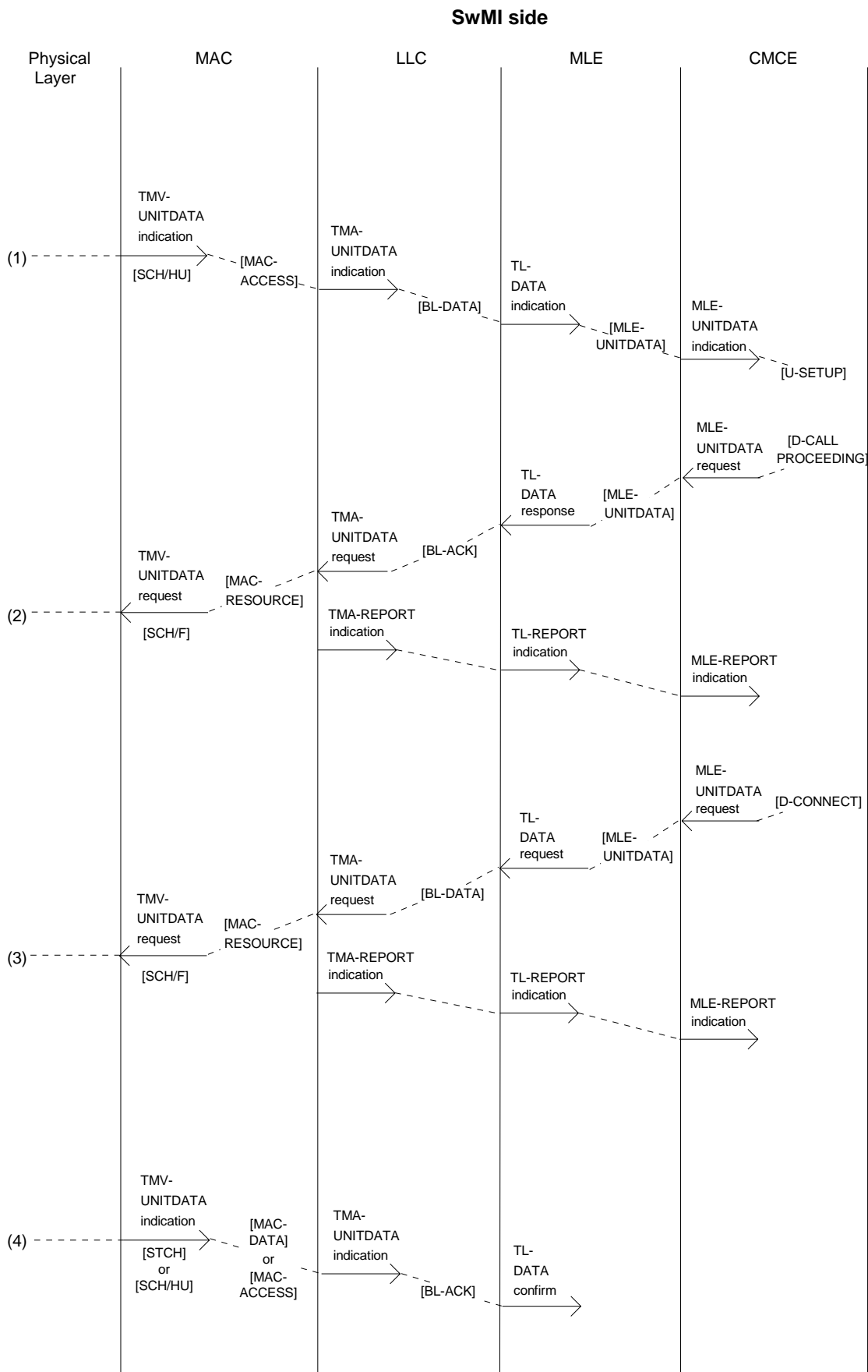
Figures 86, 87, 88 and 89 show example scenarios illustrating message exchanges for call set-up. Figures 86 and 87 show the primitives and PDUs on a calling MS air interface. Figures 88 and 89 show the primitives and PDUs on a called MS air interface.

NOTE: Some features represented here may be optional.

Refer to clauses 20 and 21 for definition of primitives and elements, and PDUs respectively. Refer to clauses 11 and 14 for the call set-up definition. The involved MLE, LLC and MAC protocols are found in clauses 18, 22 and 23, respectively.







**Figure 87: Primitives and PDUs on the calling MS air interface for an individual call with direct set-up signalling - SwMI side**

SwMI Side

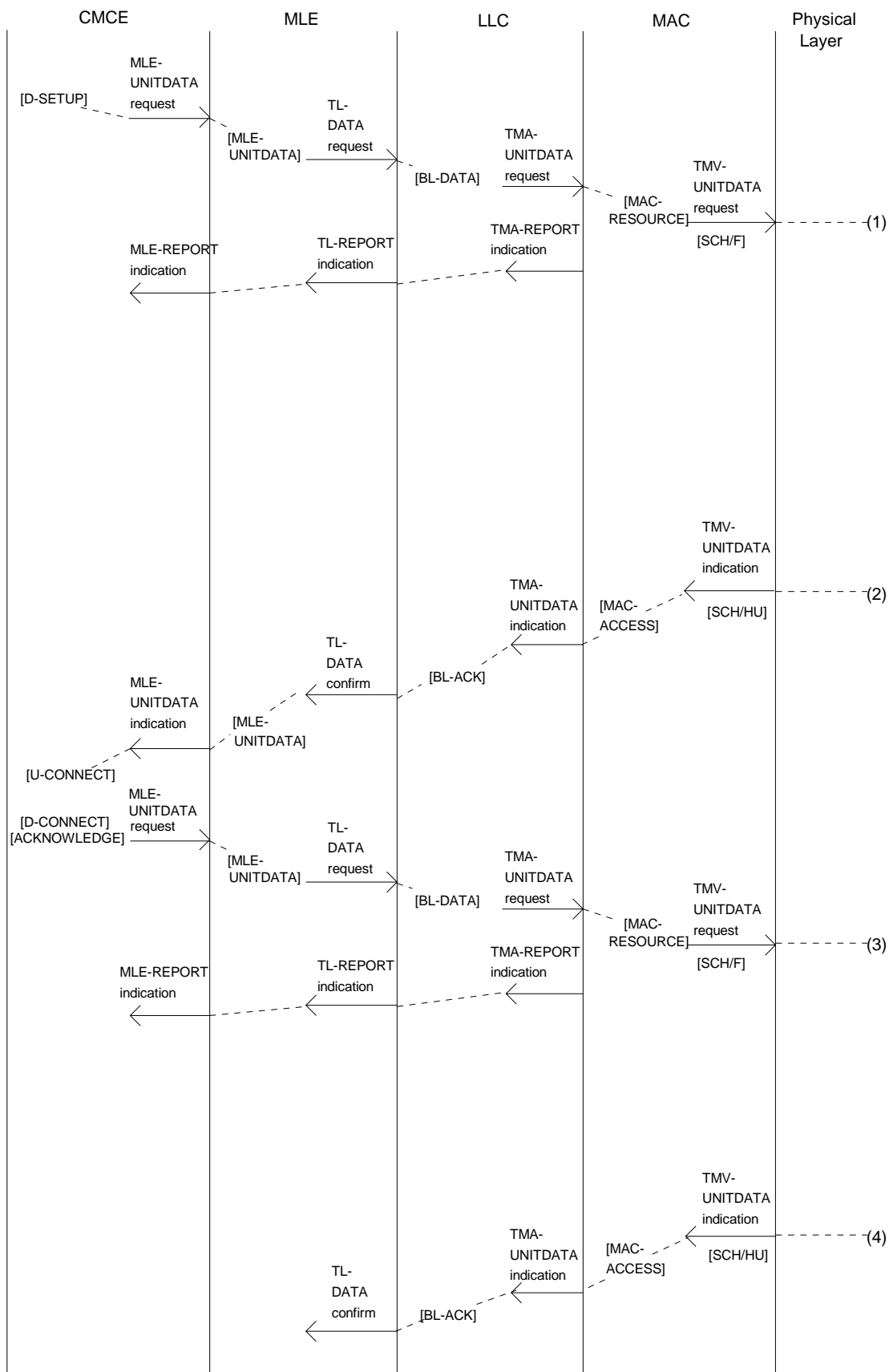
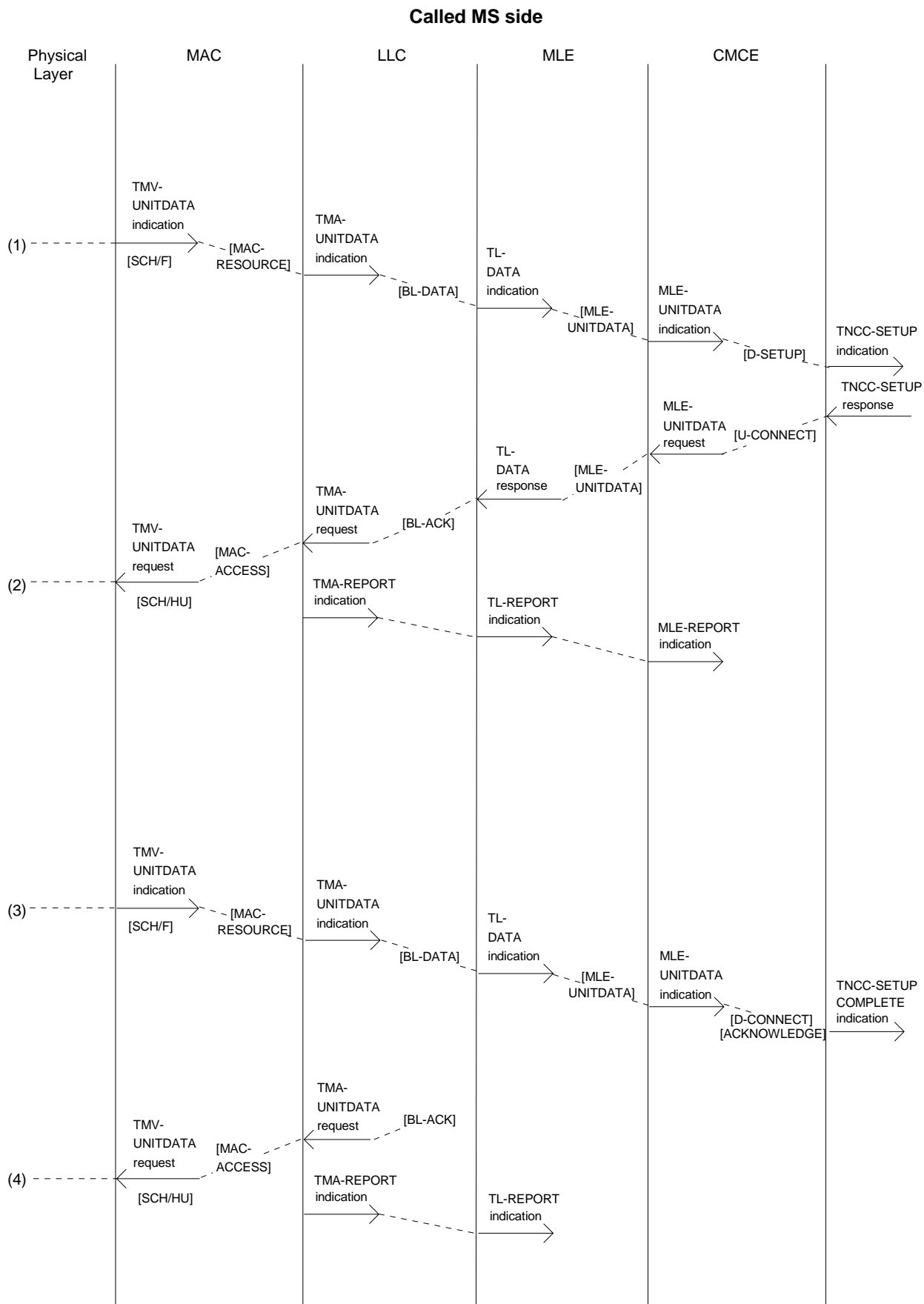


Figure 88: Primitives and PDUs on the called MS air interface for an individual call with direct set-up signalling - SwMI side



**Figure 89: Primitives and PDUs on the called MS air interface for an individual call with direct set-up signalling - Called MS side**

## 20 Layer 2 service description

### 20.1 Introduction

This clause describes the services offered by the layer 2 (see clauses 22 and 23) of the V+D TETRA air interface (see EN 300 392-1 [9], clause 6). The service description is done in terms of SAPs, primitives and their parameters. In this clause the word "shall" is used with SAPs, service primitives and parameters for traceability reasons in the protocol model, but those SAPs and primitives are not testable. As this applies inside an MS at non-specified reference points (see EN 300 392-1 [9], clauses 4 and 5), the following description does not imply any specific implementation.

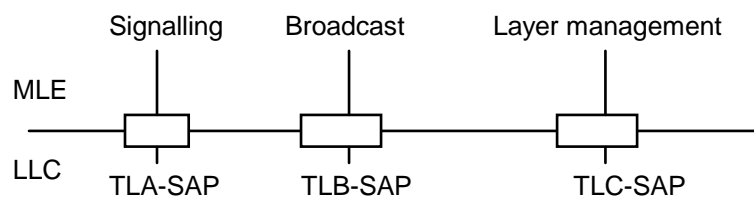
### 20.2 Layer 2 service description

#### 20.2.1 LLC SAPs

The model of the DLL comprises two sub-layers: the LLC and the MAC. The layer architecture is presented in clause 19.

Layer 2 shall provide services to the MLE through three SAPs: TLA, TLB, TLC as shown in figure 90. These services are defined in terms of primitive actions and events of the service, parameters associated with each primitive action and event, interrelationship between primitives and the valid sequences of those actions following the ISO model ISO/IEC 8348 [4].

NOTE 1: The MLE layer is also called "service user" in the layer 2 descriptions.



**Figure 90: SAPs at the MLE-LLC boundary**

The SAPs in this model are:

- TLA-SAP for signalling:
  - this SAP shall be used for data transfer and for control of the data transfer. The services are described in tables 265 and 266;
- TLB-SAP for broadcast:
  - this SAP shall be used for broadcasting purposes;
- TLC-SAP for layer management:
  - this SAP shall be used for the local control related to the cell selection/reselection in the MLE. In this model it is also used for local layer management inside one protocol stack. For example, it may be used for passing values (e.g. valid addresses, MNC, MCC) between the service user and the protocol layer 2.

NOTE 2: The peer-to-peer services provided by the TLA-SAP and the TLB-SAP correspond to services between one BS and one or several MSs. The services provided by the TLC-SAP correspond to the services within an MS.

## 20.2.2 MAC SAPs

The MAC shall provide three SAPs to the LLC: TMA-SAP, TMB-SAP and TMC-SAP. Their role is the same as the corresponding TLA-SAP, TLB-SAP and TLC-SAP.

In addition to these, the MAC shall provide an additional SAP to the U-plane application: the TMD-SAP. The services offered at this SAP are illustrated in clause 19 and described in clause 23.

## 20.2.3 Generic primitive types

Four different types of primitives are used in this protocol model as defined in ISO/IEC 8348 [4] and further explained in ETS 300 125 [10]. TETRA specific explanations are shown below in the see notes.

The REQUEST primitive type shall be used when a higher layer is requesting a service from the lower layer.

The INDICATION primitive type shall be used by a layer providing a service to notify the higher layer of any specific activity which is service related. The INDICATION primitive may be the result of an activity of the lower layer related to the primitive type REQUEST at the peer entity.

NOTE 1: Primitives at the TxC-SAP are not normally directly related to any data transfer service.

The RESPONSE primitive type shall be used by a layer to acknowledge receipt, from a lower layer, of the primitive type INDICATION.

NOTE 2: In TETRA, a RESPONSE primitive may be used with upper layer data in order to force transportation of acknowledgement and service user data (TL-SDU) in the same transmission. The TL-SDU will then be placed in the PDU containing the acknowledgement.

The CONFIRM primitive type shall be used by the layer providing the requested service to confirm that the activity has been completed.

NOTE 3: The CONFIRM primitive may be the result of an activity of the lower layer related to the primitive type RESPONSE at the peer entity and in that case it may contain service user data (TL-SDU).

## 20.2.4 Parameters definition for LLC and MAC service primitives

### 20.2.4.1 Address type

Address type shall be used by the service user to indicate to the MAC which address type will be used for transmission. It shall be used to distinguish between a user address (i.e. SSI), a management address (i.e. SMI) or an un-exchanged address (i.e. USSI).

### 20.2.4.2 Advanced link service

Advanced link service shall define which advanced link service is used:

- acknowledged; or
- unacknowledged.

### 20.2.4.3 Call release

This parameter shall indicate call release to the MS-MAC e.g. when a user within a group call wishes to leave that group call.

### 20.2.4.4 Channel

The channel parameter shall identify the frequency of the channel that the MS shall use for the requested service or that layer 2 has used for the indicated service.

#### 20.2.4.5 Channel change accepted

The channel change accepted parameter shall be used by the higher layers to indicate whether the MAC should accept or not the channel allocation indicated by the "channel change handle" parameter, see clause 20.2.4.6.

#### 20.2.4.6 Channel change handle

This parameter shall be a local identifier which acts as a reference to a particular channel allocation when the MAC requires an instruction about whether to accept that channel allocation (i.e. when the MAC sets the "channel change response required" parameter to "true"). Its implementation is outside the scope of the present document.

#### 20.2.4.7 Channel change response required

This parameter shall be used for the MAC to indicate to the higher layers that a channel allocation command was received with a particular SDU and that the MAC requires an instruction about whether to accept the channel allocation. In this case the parameter shall be set to "true"; otherwise it shall be set to "false".

#### 20.2.4.8 CSS endpoint identifier

This parameter shall be an endpoint identifier which refers to a Carrier Specific Signalling (CSS) channel that has been allocated to the MS. Alternatively, it may refer to a common channel (MCCH or common SCCH) if the MS is allocated an assigned channel on the main carrier and is permitted to use the common channel.

#### 20.2.4.9 Distribution on the 18th frame

In the case of minimum mode, this parameter shall define on which timeslot the MS shall listen to the downlink on the frame 18. It may be received by the MS at subscription or at registration.

#### 20.2.4.10 Dual watch energy economy group

This shall be one of the allowed dual watch energy economy duty cycles.

#### 20.2.4.11 Dual watch startpoint

The dual watch startpoint shall be the absolute frame and multiframe number to which the MS shall listen (if practicable) before entering the duty cycle defined by the dual watch energy economy group.

#### 20.2.4.12 Encryption, air interface

This parameter shall define whether the signalling message shall be encrypted (using air interface encryption) by the MAC or not before its transmission over the air interface. At the receiving side, it shall define whether the message has been encrypted for transmission over the air interface.

#### 20.2.4.13 Endpoint identifier

This local identifier shall be used to distinguish between multiple concurrent service instances. At the MLE-LLC boundary, the endpoint identifier indicates on which link the message shall be sent from the different basic and advanced links. At the LLC-MAC boundary, the endpoint identifier refers to which MAC resource may be used for that service. Its implementation is outside the scope of the present document.

NOTE: Refer to the handle to the request described in clause 20.2.4.22.

#### 20.2.4.14 Energy economy group

This shall be one of the eight allowed energy economy duty cycles as defined in clause 23.

#### 20.2.4.15 Energy economy startpoint

This shall be the absolute frame and multiframe number to which the MS shall listen before entering the duty cycle defined by the energy economy group.

#### 20.2.4.16 FCS flag

The FCS flag shall be used to indicate to the LLC whether extended error protection shall be applied.

#### 20.2.4.17 Half slot condition

This shall indicate whether a half traffic slot was received successfully.

#### 20.2.4.18 Half slot content

This shall define the U-plane information content that is to be carried (or was received) in a half slot in a circuit mode transmission.

#### 20.2.4.19 Half slot importance

This shall define the importance of the U-plane information that is to be carried in the circuit. It may be defined according to table 258.

**Table 258: Definition of half slot importance**

Half slot importance	Meaning
0	No importance (could be used for discontinuous TX)
1	Low
2	Medium
3	High

#### 20.2.4.20 Half slot position

This shall define the position of the U-plane information within the timeslot (i.e. first or second half slot).

#### 20.2.4.21 Half slot synchronization

This shall be a local signal provided by the MS MAC to the U-plane application so that the first half slot and second half slot parameters correspond to the first and, respectively, second half slot of the timeslot. It is provided for the purpose of this description and does not imply any particular implementation. It requires that the application keeps synchronized to the half slot in the MAC transmission.

#### 20.2.4.22 Handle to the request

This shall be a local identifier which acts as a reference to a specific service request (parent) and its children. Its implementation is outside the scope of the present document. It is considered that the handle to the request is unique over all endpoint identifiers and independent of the endpoint identifier. The handle to the request is also used on received data to link a potential acknowledgement to it.

#### 20.2.4.22a Lower layer resource availability

The lower layer resource availability shall indicate when MAC layer has lost physical resources identified by the endpoint identifier. It may be used when the physical resource is regained.



#### 20.2.4.23 Main address

The main address shall refer to the ASSI, ISSI, GSSI, SMI or USSI value as defined in EN 300 392-1 [9], clause 7. It shall consist of the MS source address for the uplink except for the low level group presence indication, for which the GSSI shall be used (refer to clause 23.5.2.3.2). It shall consist of the destination address for the downlink.

#### 20.2.4.24 MLE activity indicator

This indicates whether any of the layer 3 entities are currently active. Where the MS-MAC is capable of performing energy economy or dual watch procedure, MLE activity indicator shall be used by the MS-MAC in the management of these procedures

This indicates whether any of the layer 3 entities are currently active. It may be used by the MS-MAC in its energy economy or dual watch procedure.

#### 20.2.4.25 New endpoint identifier

This parameter shall be an endpoint identifier which refers to an additional resource allocation that has been given to the MS.

#### 20.2.4.26 Number of timeslots

The number of timeslots shall be used to define the throughput of a circuit mode service (with the selected error protection) or the maximum throughput of a packet mode service.

#### 20.2.4.27 Operating mode

The operating mode shall be used for the higher layers (i.e. CMCE) to give instructions to the MS MAC to switch between signalling and traffic mode. It may comprise the following indications:

- switch U-plane on/off;
- TX-grant flag;
- simplex/duplex flag;
- type of circuit (i.e. TCH/S, TCH/7,2, TCH/4,8, TCH/2,4);
- interleaving depth N;
- end-to-end encryption flag;
- user device;
- endpoint identifier.

#### 20.2.4.28 Path loss

Related to the cell selection/reselection mechanism and based on measurements, the path loss consists of two variables that may be calculated. Their definition and the formulas are in clause 23 together with the different procedures.

#### 20.2.4.29 PDU priority

This priority field shall be used within the LLC and MAC local to one MS. It shall not be transported to the peer entity. It may be used in the LLC to define the sending order of TL-SDUs. It shall be used in the MAC as the priority in the random access protocol. The number of supported priority levels for random access control purposes shall be eight. PDU priority ordering in a queuing process is an optional feature. The random access procedure and priorities are defined in clause 23.

### 20.2.4.29a Periodic reporting timer

The periodic reporting timer shall indicate the longest time between any transmissions from the MS to the BS, refer to 16.10.7b for definition of the values.

### 20.2.4.30 Quality indication

This quality indication may be used to indicate locally what the reception quality is.

### 20.2.4.31 Quality of Service (QoS)

The QoS parameters shall be used to facilitate the negotiation of the quality of service as defined in EN 300 392-1 [9]. The quality of service in this model is defined at the DLL as a set of TETRA specific parameters.

NOTE 1: Most of the parameters and selection of their values are either MS or network dependent.

NOTE 2: TETRA specific parameters may or may not control all aspects of each QoS parameter at the network layer SAP.

Parameter values for the throughput for constant delay services shall be as defined in table 259.

**Table 259: Throughput for constant delay services**

Parameter	Values	Remarks
Transmission rate	2 400, 4 800 or 7 200 bit/s times the Number of timeslots	TMD-SAP (negotiable)

Parameter values for the throughput for variable delay services shall be as defined in table 260.

**Table 260: Throughput for variable delay services**

Parameter	Values	Remarks
Maximum transmission rate	Number of timeslots 1 to 4	AL-SETUP PDU (negotiable)
Mean transmission rate	See clause 21 for definition	AL-SETUP PDU (negotiable)
Maximum length of TL-SDU	N.251 for basic link and N.271 for advanced link	Predefined or AL-SETUP PDU (negotiable)
TL-SDU window size	N.272	AL-SETUP PDU (negotiable)

The parameters for the residual error rate and residual error probability shall be as defined in table 261.

**Table 261: Residual error rate**

Parameter	Values	Remarks
The use of FCS	Included, not included	Local selection in the basic link services

Parameters for the transfer failure probability shall be as defined in table 262.

**Table 262: Transfer failure probability**

Parameter	Values	Remarks
Maximum number of TL-SDU retransmissions	N.252 and N.253 for basic link and N.273 and N.282 for advanced link	Predefined or AL-SETUP PDU (negotiable)
Maximum number of segment retransmissions	N.274	AL-SETUP PDU (negotiable)

Parameters for the NC Release failure probability shall be as defined in table 263.

**Table 263: NC Release failure probability**

Parameter	Values	Remarks
Number of disconnection repeats	N.263	Predefined

#### 20.2.4.32 Reconnection result

Reconnection result shall be used to indicate the result of the advanced link reconnection. The values shall be:

- success;
- random access failure;
- reconnection failure;
- reject.

#### 20.2.4.33 Report

Report shall generally indicate the progress or failure of information transfer and the cause of it.

The protocol model uses the report parameters in the protocol description at the A-SAP, C-SAP and D-SAP. The A-SAP and C-SAP reports (TLA-SAP, TLC-SAP, TMA-SAP and TMC-SAP) are defined in table 264.

**Table 264: Reports at TMA-, TMC-, TLA- and TLC-SAPs**

Report	SAP
Aborted, SDU not completely sent	TMA, TLA
Aborted, SDU sent at least once	TMA, TLA
Close	TLA
Complete transmission by stealing or by reserved access	TMA
Disconnection failure	TLA
Downlink failure	TMC, TLC
Failed transfer (e.g. maximum number of re-transmission exceeded)	TLA
First complete transmission	TLA
First complete transmission by random access	TMA
Fragmentation failure	TMA
Incoming disconnection	TLA
Layer two transmission activities continuing	TLA
Local disconnection	TLA
Maximum path delay exceeded	TMC, TLC
Random access failure	TMA, TLA
Reject	TLA
Reset	TLA
Service change	TLA
Service definition	TLA
Service not supported	TLA
Service temporarily unavailable	TLA
Set-up failure	TLA
Successful complete transmission by random access	TMA
Success, successful transfer	TLA
Usage marker mismatch	TMC, TLC
Uplink failure	TMC, TLC

NOTE: The report parameter may be used to indicate a cause or a reason and possibly position of an error.

#### 20.2.4.34 Scanning measurement method

This parameter shall specify which of the several methods of measurement the MAC shall use for the scanning process.

#### 20.2.4.35 SCCH information

This parameter shall be used in the MAC to calculate which common control channel to use when common SCCHs are in operation. It may be received by the MS at subscription or at registration.

#### 20.2.4.36 Scrambling code

This shall contain the Mobile Network Identity (MNI) as described in EN 300 392-1 [9], clause 7. It shall be given to the scrambling process in the lower MAC together with the colour code.

#### 20.2.4.37 Set-up report

This shall be used to report set-up phase with the higher layer:

- success;
- service change (proposed parameters);
- parameters acceptable; and
- parameters not acceptable.

#### 20.2.4.38 Stealing permission

This parameter shall define whether the MAC may use stealing to send this SDU. Within layer 2 it may have the following meanings:

- steal immediately;
- steal within time T.214;
- steal when convenient; or
- stealing not required.

The value "steal within time T.214" should be used for the reply to a BS message received while the MS is transmitting traffic.

#### 20.2.4.39 Stealing repeats flag

This shall be used by the higher layers in the MS to trigger a special stealing method in the MAC (see clause 23). This method should only be used for signalling at the end of an uplink traffic transmission (e.g. for U-TX-CEASED or possibly U-DISCONNECT).

#### 20.2.4.40 Stolen indication

This shall indicate whether or not the information content of a half slot is stolen for signalling purposes. At the transmitting side, this parameter may be used to force signalling mode in the MAC for either the first or both half slots within a timeslot to be transmitted. At the receiving side, this parameter shall be available to the U-plane application to enable correct handling of stolen information.

#### 20.2.4.41 Subscriber class

A subscriber class shall define a population subdivision e.g. for random access control. The operator may define the values and meaning of each class. The subscriber class information is received by the MS at subscription or at registration. If the MS receives subscriber class information at subscription, and then also is assigned subscriber class information at registration, then the information at registration shall be used.

The subscriber class parameter as supplied in primitives from layer 3 is a bit mapped field which indicates for each class whether the MS belongs to that class.

#### 20.2.4.42 Threshold level

Based on measurements as defined in clause 23, this shall be the calculated value of some global variable used in the MLE in the process of cell selection/reselection.

#### 20.2.4.43 Threshold values

The values shall be thresholds imposed in the MAC by the MLE to take a relevant action (e.g. inform MLE using suitable primitive) if some measured and/or calculated MAC parameters exceed these limits.

#### 20.2.4.44 TL-SDU

The TL-SDU is the service user data message from the MLE layer. It shall be the MLE PDU including the MLE header. It is considered here as a parameter of the service primitive.

#### 20.2.4.45 TL-SDU length

The TL-SDU length shall be the number of bits of the TL-SDU.

#### 20.2.4.46 TM-SDU

The TM-SDU is the service user data message from the LLC. It shall be the LLC PDU including the LLC header and optional FCS. It is considered here as a parameter of the service primitive.

#### 20.2.4.47 TM-SDU length

The TM-SDU length shall be the number of bits of the TM-SDU.

#### 20.2.4.47a User device

This parameter may indicate to which U-plane device the primitive is intended. The usage of user devices is outside the scope of the present document.

#### 20.2.4.48 Valid addresses

Valid addresses are the addresses that the MS MAC shall recognize as the ones attached to the MS.

### 20.3 Services provided by LLC

#### 20.3.1 Services at the TLA-SAP

The SAP may provide one or more logical channels marked by endpoint identifiers. The service user shall select the wanted service by using a service request primitive with an endpoint identifier as a parameter. The direction of the information flow can be from BS to MS, from MS to BS or both; it can also be local control information inside the MS or BS.

The TLA SAP shall be used for addressed signalling and data transfer. Table 265 shows the relationship for one LLC instance. There shall be an individual instance of LLC for each valid address.

**Table 265: Services provided at the TLA-SAP**

Service description for TLA-SAP	Address	Direction of the information flow
Point-to-point acknowledged	individual SSI	Bi-directional
Point-to-point unacknowledged	individual SSI	Bi-directional
Point-to-multipoint unacknowledged	group SSI (GSSI)	Downlink
Point-to-multipoint with presence indication	group SSI (GSSI)	Bi-directional

NOTE: In the present document only the BS may initiate the presence indication service.

Under the TLA-SAP, the LLC shall use the TMA-SAP for transferring the information down to the MAC.

The LLC may offer basic link (connectionless mode) service and advanced link (connection orientated mode) service. Within each of these services both an acknowledged and an unacknowledged data transfer is defined in the protocol. These possibilities and normal usage are shown in table 266.

**Table 266: Data transfer relationships available in the LLC**

Service offered	Acknowledged data transfer	Unacknowledged data transfer
Basic Link	Point-to-point signalling message or data transfer (short messages)	Broadcast or point-to-multipoint signalling message or data transfer (short messages downlink)
Advanced link	Point-to-point signalling or data transfer (long messages)	Point-to-multipoint signalling or data transfer (long messages downlink)

Downlink transmissions addressed to an individual MS should, in most cases, use acknowledged service. All uplink transmissions with a valid address shall use acknowledged transfer.

Normal information transfer addressed to a group of MSs shall use unacknowledged transfer on the downlink. In the case of presence indication request the BS shall use a kind of acknowledged data transfer, with reserved access for the acknowledgement, knowing that if there are multiple responses from the MSs in the group, there is a risk of collision that will make the responses un-decodeable. If the message can be decoded, the BS will know that there was at least one responding MS. If there are collisions, the BS may assume presence of MSs from the measured RSSI on the uplink. How this measurement is done is outside the scope of the present document.

The advanced link acknowledged mode may be used in all cases where an acknowledged service is required for a point-to-point data transfer. The advanced link may also be used for point-to-multipoint data transfer in unacknowledged mode. In this case data transfer normally consists of set-up phase, data transfer phase possibly with repetition and selective re-assembly of received data and disconnection phase.

### 20.3.2 Services at the TLB-SAP

The TLB-SAP shall be used for un-addressed data transfer as presented in table 267. This includes the system information broadcast messages. In the protocol model there are no LLC functions under the TLB-SAP and the LLC shall convey information directly to the MAC using the TMB-SAP.

**Table 267: Services provided at the TLB-SAP**

Service description for TLB-SAP	Address	Direction
Point-to-multipoint unacknowledged	none	Downlink

### 20.3.3 Services at the TLC-SAP

The TLC-SAP shall be used in this model for all local layer management control, such as scanning control and signal quality measurements (see table 268). TLC-SAP does not provide any data transfer service over the air interface.

**Table 268: Services provided at the TLC-SAP**

Service description for TLC-SAP	Address	Direction
Local management and control	None	Bi-directional within the MS protocol stack

## 20.3.4 LLC service primitives

The following tables summarize LLC service primitives. If the service primitive is provided or not provided in both the basic and advanced links, then yes and no are used respectively. In other cases the LLC link type is mentioned.

**Table 269: TLA-SAP service primitives**

Service primitive	request	Indication	Response	Confirm
TL-CANCEL	yes	no	no	no
TL-CONNECT	advanced link	advanced link	advanced link	advanced link
TL-DATA	yes	yes	basic link	yes
TL-DISCONNECT	advanced link	advanced link	no	advanced link
TL-RECEIVE	no	advanced link	no	no
TL-RELEASE	advanced link	yes	no	no
TL-RECONNECT	advanced link	no	no	advanced link
TL-REPORT	no	yes	no	no
TL-UNITDATA	yes	yes	no	optional

NOTE: TL-RECEIVE primitive is valid for SwMI only.

**Table 270: TLB-SAP service primitives**

Service primitive	request	Indication	Response	Confirm
TL-SYNC	yes, BS	yes, MS	no	no
TL-SYSINFO	yes, BS	yes, MS	no	no

**Table 271: TLC-SAP service primitives**

Service primitive	Request	Indication	Response	Confirm
TL-CONFIGURE	yes	yes	no	yes
TL-MEASUREMENT	no	yes	no	no
TL-MONITOR	no	yes	no	no
TL-MONITOR-LIST	yes	no	no	no
TL-REPORT	no	yes	no	no
TL-SCAN	yes	no	no	yes
TL-SCAN-REPORT	no	yes	no	no
TL-SELECT	yes	yes	yes	yes

## 20.3.5 Service primitive descriptions

In tables 272 to 290 inclusive, which define parameters for the primitives, the following keys are used:

- M: Mandatory;
- C: Conditional;
- -: Not used.

NOTE: The exact conditions of the presence for some conditional parameters are implied by the corresponding information flows and are not detailed in the service descriptions.

### 20.3.5.1 Primitives at the TLA-SAP (MLE-LLC)

#### 20.3.5.1.1 TL-CANCEL primitive

A TL-CANCEL request primitive may be used locally for an MS or BS to cancel a previous request. This primitive shall not send messages over the air interface. The parameters shall be as defined in table 272.

**Table 272: Parameters used in the TL-CANCEL primitive**

Parameter	Request
Handle to the request (see note)	M
NOTE: Not sent over the air interface.	

#### 20.3.5.1.2 TL-CONNECT primitive

The connection primitives, if required prior to a transfer, shall be used to establish a LLC advanced link. The parameters shall be as defined in table 273.

TL-CONNECT request primitive shall be used by the layer 2 service user to initiate the establishment of an advanced link with a certain quality of service. It may also reset the established link.

TL-CONNECT indication primitive shall be used by the layer 2 to inform the layer 2 service users that the establishment of an advanced link with a certain quality of service or the reset of the current advanced link has been requested.

TL-CONNECT response primitive shall be used by the layer 2 service users to accept the establishment or the reset of the advanced link with a certain quality of service. According to the available resources, the value of the service parameters may also be modified (lower grade of service) in the response. In such a case, the advanced link characteristics will match these new features.

TL-CONNECT confirm primitive shall be used by the layer 2 to inform the layer 2 service users that the establishment or re-establishment (reset) of the advanced link has been completed with a certain quality of service as indicated in the request primitive.

**Table 273: Parameters used in the TL-CONNECT primitive**

Parameter	Request	Indication	Response	Confirm
Address type	M	M	M	M
Main address	M	M	M	M
Scrambling code (see note)	M	M	M	M
Endpoint identifier (see note)	C	M	M	M
New endpoint identifier (see note)	-	C	-	C
CSS endpoint identifier (see note)	-	C	-	C
PDU priority (see note)	M	-	M	-
Stealing permission (see note)	M	-	M	-
Subscriber class (see note)	M	-	M	-
Quality of Service	M	M	M	M
Advanced link service	M	M	M	M
Encryption, air interface	M	M	M	M
Channel change response required (see note)	-	M	-	M
Channel change handle (see note)	-	C	-	C
Handle to the request (see note)	M	M	M	M
Set-up report	M	M	M	M
NOTE: Not sent over the air interface.				

NOTE: The usage of the advanced link service type indication in confirm primitive applies only to the BS side of the protocol.



### 20.3.5.1.3 TL-DATA primitive for the advanced link

Parameters in acknowledged advanced link service for the following primitives shall be as defined in table 274.

TL-DATA request primitive shall be used by the layer 2 service user to request transmission of a TL-SDU.

TL-DATA indication primitive shall be used by the layer 2 to deliver the received TL-SDU to the layer 2 service user.

TL-DATA confirm primitive shall be used by the layer 2 to inform the layer 2 service user that it has completed successfully the transmission of the requested TL-SDU.

**Table 274: Parameters used in the TL-DATA primitive for advanced link**

Parameter	Request	Indication	Confirm
Address type	M	M	M
Main address	M	M	M
Endpoint identifier (see note)	M	M	M
New endpoint identifier (see note)	-	C	C
CSS endpoint identifier (see note)	-	C	C
TL-SDU	M	C	-
TL-SDU length (see note)	M	-	-
Scrambling code	M	M	M
PDU priority (see note)	M	-	-
Stealing permission (see note)	M	-	-
Subscriber class (see note)	M	-	-
Encryption, air interface	M	M	M
Channel change response required (see note)	-	M	M
Channel change handle (see note)	-	C	C
Handle to the request (see note)	M	-	M
Report	-	-	M
NOTE:	Not sent over the air interface.		

### 20.3.5.1.4 TL-DATA primitive for the basic link

In the acknowledged basic link data transfer service the parameters for the following primitives shall be as defined in table 275.

TL-DATA request primitive shall be used by the layer 2 service user to request transmission of a TL-SDU. The TL-SDU will be acknowledged by the peer entity.

TL-DATA indication primitive shall be used by the layer 2 to deliver the received TL-SDU to the layer 2 service user.

TL-DATA response primitive shall be used by the layer 2 service user to respond to the previous TL-DATA indication. The TL-DATA response may contain a TL-SDU. That TL-SDU will be sent without an explicit acknowledgement from the peer entity.

TL-DATA confirm primitive shall be used by the layer 2 to inform the layer 2 service user that it has completed successfully the transmission of the requested TL-SDU. Depending on the availability of the response at the peer entity before transmission of the acknowledgement, the confirm may or may not carry a TL-SDU.

**Table 275: Parameters used in the TL-DATA primitive for basic link**

Parameter	Request	Indication	Response	Confirm
Address type	M	M	M	M
Main address	M	M	M	M
Endpoint identifier (see note)	C	C	C	C
New endpoint identifier (see note)	-	C	-	C
CSS endpoint identifier (see note)	-	C	-	C
TL-SDU	M	C	M	C
TL-SDU length (see note)	M	-	M	-
Scrambling code	M	M	M	M
PDU priority (see note)	M	-	M	-
Stealing permission (see note)	M	-	M	-
Subscriber class (see note)	M	-	M	-
FCS flag	M	M	M	M
Encryption, air interface	M	M	M	M
Stealing repeats flag (see note)	C	-	C	-
Channel change response required (see note)	-	M	-	M
Channel change handle (see note)	-	C	-	C
Handle to the request (see note)	M	M	M	M
Report	-	-	-	M
NOTE: Not sent over the air interface.				

### 20.3.5.1.5 TL-DISCONNECT primitive

The disconnection primitives shall be used to disconnect a LLC advanced link. The parameters shall be as defined in table 276.

**Table 276: Parameters used in the TL-DISCONNECT primitive**

Parameter	Request	Indication	Confirm
Address type	M	M	M
Main address	M	M	M
Endpoint identifier (see note)	M	M	M
New endpoint identifier (see note)	-	C	C
CSS endpoint identifier (see note)	-	C	C
Scrambling code	M	M	M
PDU priority (see note)	M	-	-
Stealing permission (see note)	M	-	-
Subscriber class (see note)	M	-	-
Advanced link service	M	M	M
Encryption, air interface	M	M	M
Channel change response required (see note)	-	M	M
Channel change handle (see note)	-	C	C
Handle to the request (see note)	M	-	M
Report	M	M	M
NOTE: Not sent over the air interface.			

NOTE 1: The only valid value for the report field in TL-DISCONNECT request primitive is "Close".

NOTE 2: The usage of the advanced link service type indication in confirm primitive applies only to the BS side of the protocol.

### 20.3.5.1.5a TL-RECEIVE primitive (TLA-SAP)

TL-RECEIVE indication primitive shall be used by the layer 2 to report to the layer 2 service user that the reception of a TL-SDU has started or is ongoing on the layer 2. This primitive is valid for SwMI only.

Parameters for this primitive shall be as defined in table 276A.

**Table 276A: Parameters used in the TL-RECEIVE primitive (TLA-SAP)**

Parameter	Indication
Address type	M
Main address	M
Endpoint identifier (see note)	M
NOTE: Not sent over the air interface.	

### 20.3.5.1.6 TL-RECONNECT primitive

The reconnection primitives shall be used to reconnect an advanced link after a cell reselection. The parameters shall be as defined in table 276A.

TL-RECONNECT request primitive shall be used by the layer 2 service user in the MS after a cell reselection to initiate the reconnection of the advanced link which was being used in the previous cell. If successful, all parameters agreed for the advanced link in the previous cell shall apply in the new cell.

TL-RECONNECT confirm primitive shall be used by the LLC to inform the layer 2 service user that the attempt to reconnect the advanced link has been successfully completed. A successful reconnection shall result in no change to the parameters which were agreed during the establishment of the advanced link in question.

**Table 276A: Parameters used in the TL-RECONNECT primitive**

Parameter	Request	Confirm
Address type	M	M
Main address	M	M
Endpoint identifier (see note)	M	M
New endpoint identifier (see note)	-	C
CSS endpoint identifier (see note)	-	C
Scrambling code	M	M
PDU priority (see note)	M	-
Stealing permission (see note)	M	-
Subscriber class (see note)	M	-
Encryption, air interface	M	M
Handle to the request (see note)	M	M
Reconnection result	-	M
NOTE: Not sent over the air interface.		

### 20.3.5.1.7 TL-RELEASE primitive

The TL-RELEASE primitive shall be used to disconnect locally an LLC advanced link, when a disconnection is recognized by the service user and LLC might no longer perform a disconnection with the peer entity.

It shall also be used when the MAC has indicated that the connection on this channel has been lost.

The parameters in this primitive shall be as defined in table 277.

**Table 277: Parameters used in the TL-RELEASE primitive**

Parameter	Request	Indication
Address type (see note)	M	M
Main address (see note)	M	M
Endpoint identifier (see note)	M	M
NOTE: Not sent over the air interface.		

### 20.3.5.1.8 TL-REPORT primitive (TLA-SAP)

TL-REPORT indication primitive shall be used by the layer 2 to report to the layer 2 service user the progress or failure of a request procedure. The progress indication shall be passed as the Report parameter. This primitive may be issued to the layer 2 service user as an indication that an unrecoverable error has occurred.

This primitive is also used to indicate that MAC has received a channel change command without an SDU and cannot decide whether it should obey the request or not as the change will affect to other concurrent services.

Parameters for this primitive shall be as defined in table 278.

NOTE: The completion of the requested service is indicated by the same primitive name with the type confirm.

**Table 278: Parameters used in the TL-REPORT primitive (TLA-SAP)**

Parameter	Indication
Handle to the request (see note 1)	C (see note 2)
Report (see note 1)	M
Channel change response required (see note 1)	C (see note 3)
Channel change handle (see note 1)	C (see note 3)
Endpoint identifier (see note 1)	C (see note 3)
NOTE 1: Not sent over the air interface.	
NOTE 2: Mandatory when data transmission is reported.	
NOTE 3: Mandatory when a channel change is reported.	

### 20.3.5.1.9 TL-UNITDATA primitive

In the unacknowledged data transfer service the parameters for the following primitives shall be as defined in table 279 for the basic link and as defined in table 280 for the advanced link.

TL-UNITDATA request shall be used by the layer 2 service user to request layer 2 to transmit a TL-SDU.

TL-UNITDATA indication shall be used to deliver the received TL-SDU to the layer 2 service user.

TL-UNITDATA confirm may be used to indicate completion of sending of the requested TL-SDU.

**Table 279: Parameters used in the TL-UNITDATA primitive in basic link**

Parameter	Request	Indication	Confirm (see note 2)
Address type	M	M	M
Main address	M	M	M
Endpoint identifier (see note 1)	C	C	C
New endpoint identifier (see note 1)	-	C	-
CSS endpoint identifier (see note 1)	-	C	-
TL-SDU	M	C	-
TL-SDU length (see note 1)	M	-	-
Scrambling code	M	M	-
PDU priority (see note 1)	M	-	-
Stealing permission (see note 1)	M	-	-
Subscriber class (see note 1)	M	-	-
FCS flag	M	M	-
Encryption, air interface	M	M	-
Channel change response required (see note 1)	-	M	-
Channel change handle (see note 1)	-	C	-
Handle to the request (see note 1)	M	-	M
Report	-	C	C
NOTE 1: Not sent over the air interface.			
NOTE 2: In this case, the confirm is a local knowledge of the sending entity.			

**Table 280: Parameters used in the TL-UNITDATA primitive in advanced link**

Parameter	Request	Indication	Confirm (see note 2)
Address type	M	M	M
Main address	M	M	M
Endpoint identifier (see note 1)	M	M	M
New endpoint identifier (see note 1)	-	C	-
CSS endpoint identifier (see note 1)	-	C	-
TL-SDU	M	M	-
TL-SDU length (see note 1)	M	-	-
Scrambling code	M	M	-
PDU priority (see note 1)	M	-	-
Stealing permission (see note 1)	M	-	-
Subscriber class (see note 1)	M	-	-
Encryption, air interface	M	M	-
Channel change response required (see note 1)	-	M	-
Channel change handle (see note 1)	-	C	-
Handle to the request (see note 1)	M	-	M
Report	-	C	C
NOTE 1: Not sent over the air interface.			
NOTE 2: In this case, the confirm is a local knowledge of the sending entity.			

### 20.3.5.2 Signals at the TLA-SAP (MLE-LLC)

The TLA-SAP signals (FLOW-READY signal and FLOW-NOT-READY signal) are used in the protocol description of the MS's message-buffering interface between the LLC service user (MLE) and LLC. As this is purely local to an MS, the following description is provided for information only.

The FLOW-READY signal shall be used by the LLC service user in the MS to indicate to the LLC when it is capable of receiving more user data TL-SDUs in TL-DATA indication primitives.

The FLOW-NOT-READY signal shall be used by the LLC service user in the MS to indicate to the LLC when it is not capable of receiving more user data TL-SDUs in TL-DATA indication primitives.

NOTE: The validity time of one FLOW-NOT-READY signal at the LLC is limited by T.271 and T.272 in the sending and receiving entities respectively.

The parameters in the flow control signal shall be:

- address type;
- main address; and
- endpoint identifier.

The endpoint identifier will not be sent over the air.

### 20.3.5.3 Primitives at the TLB-SAP (MLE-LLC)

In the present document the LLC layer does not have any TMB-SAP related functions. The requests at the TLB-SAP are directly mapped as requests at the TMB-SAP and the indications at the TMB-SAP are directly transported to TLB-SAP indications.

### 20.3.5.3.1 TL-SYNC primitive

The request primitive shall be used in the BS to broadcast synchronization information. The indication primitive shall be used in the MS to transport the received TM-SDU part of the synchronization information via LLC to MLE. The BS MAC will broadcast the information at suitable intervals. Every new request may change the content of the broadcast information. The parameters shall be as defined in table 281.

**Table 281: Parameters used in the TL-SYNC primitive**

Parameter	Request	Indication
Channel	M	M
TL-SDU	M	M
TL-SDU length	M	M
Priority (not sent over the air interface)	M	-

### 20.3.5.3.2 TL-SYSINFO primitive

The request primitive shall be used in the BS to broadcast system related information needed in the process of cell selection on the BNCH. The indication primitive shall be used in the MS to transport the received TM-SDU via LLC to MLE. The BS MAC will broadcast the information at suitable intervals. Every new request may change the content of the broadcast information. The parameters shall be as defined in table 282.

**Table 282: Parameters used in the TL-SYSINFO primitive**

Parameter	Request	Indication
Channel	M	M
TL-SDU	M	M
TL-SDU length	M	M
Priority (Not sent over the air interface)	M	-

### 20.3.5.4 Primitives at the TLC-SAP (MLE-LLC)

In the present document the LLC layer does not have any TLC-SAP related functions. The requests and responses at the TLC-SAP are directly mapped as requests and responses at the TMC-SAP and the indications and confirms at the TMC-SAP are directly transported to TLC-SAP indications and confirms.

## 20.3.5.4.1 TL-CONFIGURE primitive

**TL-CONFIGURE indication:** this primitive shall be indicate when lower layer resources are lost. It may be used to indicated when the resources are regained. The parameters shall be as defined in table 283.

**TL-CONFIGURE request, confirm:** this primitive shall be used to set up and configure the layer 2 according to the chosen cell parameters and the current state of the MS. The parameters shall be as defined in table 283.

Table 283: Parameters used in the TL-CONFIGURE primitive

Parameter	Request (see note)	Indication (see note)	Confirm (see note)
Threshold values	C	-	C
Distribution on 18th frame	C	-	C
SCCH information	C	-	C
Energy economy group	C	-	C
Energy economy startpoint	C	-	C
Dual watch energy economy group	C	-	C
Dual watch startpoint	C	-	C
MLE activity indicator	C	-	-
Channel change accepted	C	-	-
Channel change handle	C	-	-
Operating mode	C	-	C
Call release	C	-	C
Valid addresses	C	-	C
Endpoint identifier	-	M	-
Lower layer resource availability	-	M	-
Periodic reporting timer	O	-	-
NOTE: Not sent over the air interface.			

## 20.3.5.4.2 TL-MEASUREMENT primitive

**TL-MEASUREMENT indication:** this primitive shall be used to indicate to the upper layer the quality of the link of the current serving cell, based on the weighted result of the measured and acquired parameters. The parameters shall be as defined in table 284.

Table 284: Parameters used in the TL-MEASUREMENT primitive

Parameter	Indication (see note)
Channel	M
Path loss C1	M
Quality indication	C
NOTE: Not sent over the air interface.	

## 20.3.5.4.3 TL-MONITOR primitive

**TL-MONITOR indication:** this primitive shall be used at the TLC-SAP to indicate the result of the monitoring of one particular RF channel. This shall be a consequence of the action started by TL-MONITOR-LIST request. The parameters shall be as defined in table 285.

Table 285: Parameters used in the TL-MONITOR primitive

Parameter	Indication (see note)
Channel	M
Path loss C2	M
Quality indication	C
NOTE: Not sent over the air interface.	

## 20.3.5.4.4 TL-MONITOR-LIST primitive

**TL-MONITOR-LIST request:** this primitive shall be used at the TLC-SAP to start the monitoring of a list of RF channels given as parameters. The parameters shall be as defined in table 286.

**Table 286: Parameters used in the TL-MONITOR-LIST primitive**

Parameter	Request (see note 1)
Channel	M
Channel (see note 2)	C
NOTE 1: Not sent over the air interface.	
NOTE 2: May be repeated.	

## 20.3.5.4.5 TL-REPORT primitive (TLC-SAP)

**TL-REPORT indication:** this primitive shall be used to report locally to MLE about the status of an action undertaken at the reception of a request. It may also be used to report usage marker mismatch, downlink failure, uplink failure or when the maximum path delay has been exceeded. The parameters shall be as defined in table 287.

**Table 287: Parameters used in the TL-REPORT primitive (TLC-SAP)**

Parameter	Indication (see note 1)
Handle to the request	C
Report	M
Endpoint identifier	C (see note 2)
NOTE 1: Not sent over the air interface.	
NOTE 2: Used to identify concurrent services.	

## 20.3.5.4.6 TL-SCAN primitive

**TL-SCAN request, confirm:** this primitive shall be used at the TLC-SAP to start the scanning of a defined RF channel given as a parameter, together with the type of scanning (interrupting or not). The parameters shall be as defined in table 288.

**Table 288: Parameters used in the TL-SCAN primitive**

Parameter	Request (see note)	Confirm (see note)
Channel	M	M
Scanning measurement method	M	M
Threshold level	C	M
Report	-	M
NOTE: Not sent over the air interface.		

## 20.3.5.4.7 TL-SCAN-REPORT primitive

**TL-SCAN-REPORT indication:** this primitive shall be used at the TLC-SAP to report locally the updated measurement of the path loss parameter after scanning has been completed. It shall be based on the updated signal strength measurements. The parameters shall be as defined in table 289.

**Table 289: Parameters used in the TL-SCAN-REPORT primitive**

Parameter	Indication
Channel (see note)	M
Threshold level (path loss C1) (see note)	M
Report (see note)	C
NOTE: Not sent over the air interface.	



## 20.3.5.4.8 TL-SELECT primitive

**TL-SELECT request, indication, response, confirm:** this primitive shall be used at the TLC-SAP to choose the RF channel onto which the radio will have to tune. The request and confirm shall be used when the MLE instructs the MAC to change channel. The indication shall be used by the MAC to inform the MLE of a channel change under the control of the BS. The response shall be used for a cell change. The parameters shall be as defined in table 290.

Table 290: Parameters used in the TL-SELECT primitive

Parameter	Request	Indication	Response	Confirm
Channel (see note)	M	M	M	M
Threshold level (see note)	C	M	C	M
Main carrier number	C	-	C	C
Report (see note)	-	C	C	C

NOTE: Not sent over the air interface.

NOTE: The main carrier number is generally only used for announced type 1 cell reselection when a channel change directs the MS to a traffic channel on a new cell. On receiving TMC-SELECT indication, the MLE returns TMC-SELECT response indicating the main carrier of the new cell and enabling the MAC to reference the SYNC/SYSINFO information received when it previously scanned that main carrier.

## 20.3.6 State diagram for the basic link

The state transition diagram in figure 91 applies to the basic link services.

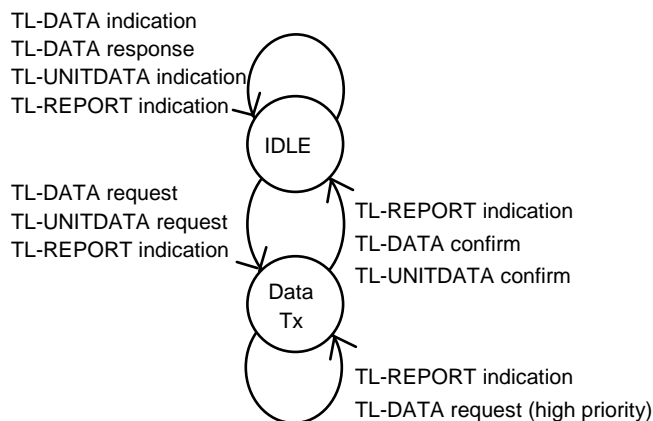


Figure 91: State transition diagram in basic link at TL-SAP

### 20.3.7 State diagram for advanced link

The state transition diagram in figure 92 applies to the advanced link.

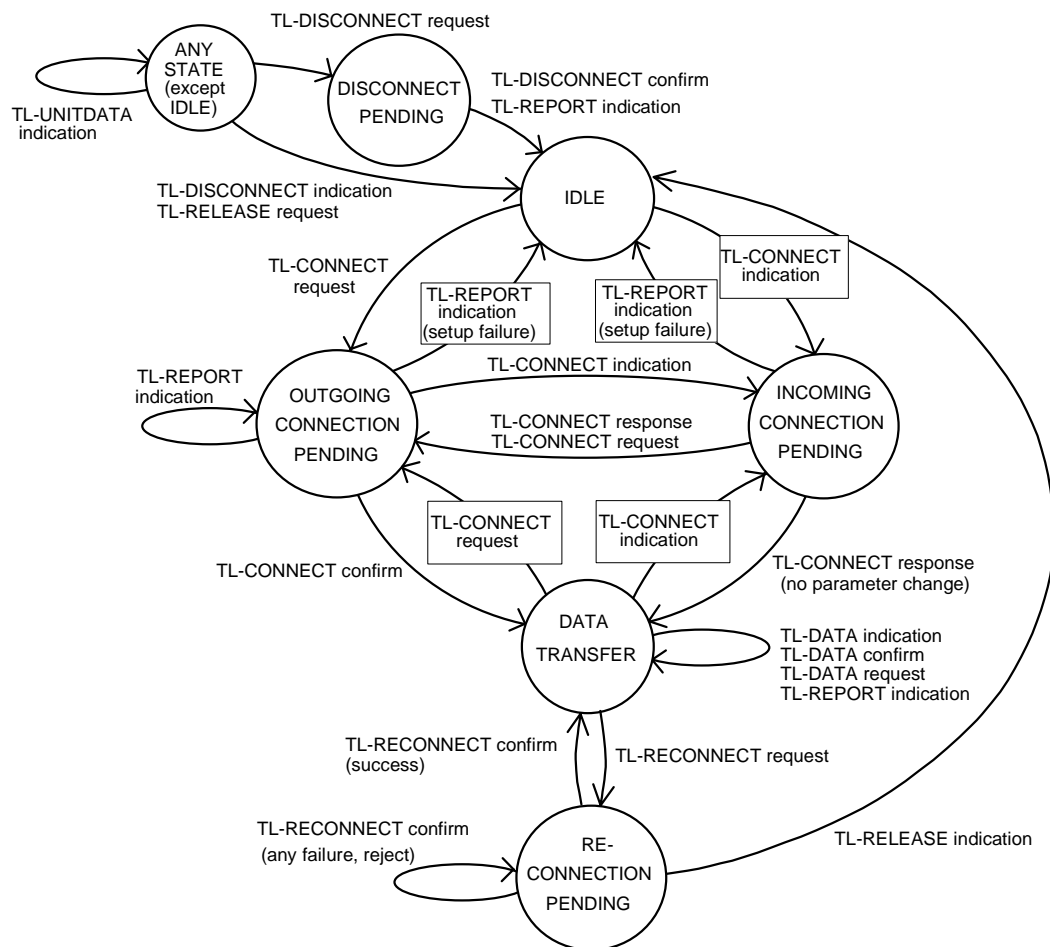


Figure 92: State transition in connection mode at MLE-LLC SAP (advanced link)

## 20.4 Services provided by the MAC

The MAC shall provide services to higher layers in the protocol architecture via four SAPs. These are TMA-SAP, TMB-SAP, TMC-SAP and TMD-SAP. The first three correspond to the TLA-SAP, TLB-SAP and TLC-SAP in the LLC. TMD-SAP shall be used for transfer of user information in circuit mode. The MAC layer service primitives shall be as listed in tables 291 to 294 inclusive.

NOTE: The following description refers to the protocol definition, but does not imply any implementation. The LLC-MAC boundary and TMD-SAP are internal layer boundaries defined to clarify the protocol description. They are not testable boundaries.

Table 291: TMA-SAP service primitives

Service primitive	Request	Indication	Response	Confirm
TMA-CANCEL	yes	no	no	no
TMA-RELEASE	no	yes	no	no
TMA-REPORT	no	yes	no	no
TMA-UNITDATA	yes	yes	no	no

**Table 292: TMB-SAP service primitives**

Service primitive	request	Indication	Response	Confirm
TMB-SYNC	yes, BS	yes, MS	no	no
TMB-SYSINFO	yes, BS	yes, MS	no	no

**Table 293: TMC-SAP service primitives**

Service primitive	request	Indication	Response	Confirm
TMC-CONFIGURE	yes	yes	no	yes
TMC-MEASUREMENT	no	yes	no	no
TMC-MONITOR	no	yes	no	no
TMC-MONITOR-LIST	yes	no	no	no
TMC-REPORT	no	yes	no	no
TMC-SCAN	yes	no	no	yes
TMC-SCAN-REPORT	no	yes	no	no
TMC-SELECT	yes	yes	yes	yes

**Table 294: TMD-SAP service primitives**

Service primitive	request	Indication	Response	Confirm
TMD-REPORT	no	yes	no	no
TMD-UNITDATA	yes	yes	no	no

## 20.4.1 Services at the TMA-SAP

The TMA-SAP shall be used for transfer of signalling and packet data information on the air interface. The TMA-SAP provides the following services to the LLC layer:

- data manipulation (PDU composition/decomposition);
- transfer of PDUs as indicated in the following clauses.

### 20.4.1.1 Service primitives at the TMA-SAP

#### 20.4.1.1.1 TMA-CANCEL primitive

**TMA-CANCEL request:** this primitive shall be used to cancel a TMA-UNITDATA request that was submitted by the LLC. The parameters shall be as defined in table 295.

**Table 295: Parameters used in the TMA-CANCEL primitive**

Parameter	Request (see note)
Handle to the request	M
NOTE: Not sent over the air interface.	

#### 20.4.1.1.2 TMA-RELEASE primitive

The release primitive may be used when the MAC leaves a channel in order to indicate that the connection on that channel is lost (e.g. to indicate local disconnection of any advanced links on that channel). The parameters in this primitive shall be as defined in table 296.

**Table 296: Parameters used in the TMA-RELEASE primitive**

Parameter	Indication
Endpoint identifier (see note)	M
NOTE: Not sent over the air interface.	

### 20.4.1.1.3 TMA-REPORT primitive

TMA-REPORT indication shall be used by the MAC to report on the progress or failure of a request procedure. The result of the transfer shall be passed as a report parameter. The parameters shall be as defined in table 297.

**Table 297: Parameters used in the TMA-REPORT primitive**

Parameter	Indication (see note)
Handle to the request	M
Report	M
NOTE: Not sent over the air interface.	

### 20.4.1.1.4 TMA-UNITDATA primitive

TMA-UNITDATA request shall be used to request the MAC to transmit a TM-SDU.

TMA-UNITDATA indication shall be used by the MAC to deliver a received TM-SDU.

TMA-UNITDATA indication may also be used with no TM-SDU if the MAC needs to inform the higher layers of a channel allocation received without an associated TM-SDU.

The parameters shall be as defined in table 298.

**Table 298: Parameters used in the TMA-UNITDATA primitive**

Parameter	Request	Indication
Handle to the request (see note 1)	M	-
TM-SDU	M	C
TM-SDU length, (see note 2)	M	-
Main address	M	M
Address Type	M	M
Scrambling code	M	M
Endpoint identifier (see note 1)	C	C
New endpoint identifier (see note 1)	-	C
CSS endpoint identifier (see note 1)	-	C
PDU priority (see note 1)	M	-
Stealing permission (see note 1)	M	-
Subscriber Class (see note 1)	M	-
Encryption, air interface	M	M
Stealing repeats flag (see note 1)	C	-
Channel change response required (see note 1)	-	M
Channel change handle (see note 1)	-	C
NOTE 1: Not sent over the air interface.		
NOTE 2: If the length indicates a Null PDU, then PDU priority shall be the lowest value and stealing shall not be permitted.		

### 20.4.1.2 Signals at the TMA-SAP

The TMA-SAP signals (DATA-IN-BUFFER signal and MAC-READY signal) are used in the protocol description of the MS's message-buffering interface between LLC and MAC. As this is purely local to an MS, the following description is provided for information only.

The DATA-IN-BUFFER signal is used by the LLC in the MS to indicate to the MAC when it has signalling messages to send, and to indicate the amount of data outstanding.

The parameters in the DATA-IN-BUFFER signal are as follows:

- a) address type;
- b) main address;
- c) amount of data in LLC buffer:
  - this is the total amount of outstanding data to be sent with this address (on the channel corresponding to the specified endpoint identifier), and not yet given to the MAC; it is the total amount of data with this address for both basic link and advanced link messages, including acknowledgements.
- d) priority of highest priority message, and highest stealing permission:
  - this is the highest PDU priority and stealing permission parameter for messages in the LLC message buffer for this address (for the specified endpoint identifier).
- e) endpoint identifier.

The MAC-READY signal is issued by the MAC in the MS to the LLC when the MAC is ready to send a MAC block. Then the LLC will usually issue a TMA-UNITDATA request primitive to the MAC, containing a TM-SDU to be sent in the MAC block.

The parameters in the MAC-READY signal are as follows:

- a) address type;
- b) main address;
- c) size of TM-SDU in this MAC block:
  - this is the maximum size of TM-SDU that can be carried in the current MAC block (i.e. the maximum size without requiring fragmentation).
- d) maximum size of TM-SDU:
  - this is the maximum size of TM-SDU that can be handled in the MAC at this time (e.g. the maximum size of fragmented TM-SDU).
- e) endpoint identifier.

### 20.4.1.3 Mapping of the service primitives between LLC and MAC under the TxA-SAP

The LLC shall control the relationships between the LLC data transfer service primitives offered to the MLE and the data transfer service primitives offered by the MAC to the LLC. Table 299 shows these relationships at the TLA-SAP (MLE-LLC) and the TMA-SAP (LLC-MAC).

**Table 299: Correspondence between MAC and LLC at the TMA-SAP and TLA-SAP**

LLC Service Primitives (TLA-SAP)	MAC Service Primitive (TMA-SAP)
TL-CONNECT request TL-CONNECT response TL-DATA request TL-DATA response TL-DISCONNECT request TL-RECONNECT request TL-UNITDATA request	TMA-UNITDATA request
TL-CONNECT indication TL-CONNECT confirm TL-DATA indication TL-DATA confirm TL-DISCONNECT indication TL-DISCONNECT confirm TL-RECONNECT confirm TL-UNITDATA indication	TMA-UNITDATA indication
TL-CANCEL request	TMA-CANCEL request
TL-RELEASE indication	TMA-RELEASE indication
TL-RELEASE request	None
TL-REPORT indication	TMA-UNITDATA indication or TMA-REPORT indication or not applicable
NOTE 1: All the service primitives at the TMA-SAP use signalling channels (SCH or STCH), except for the local primitives (CANCEL, RELEASE, REPORT).	
NOTE 2: A TL-REPORT may be generated in the LLC without a report from the lower layer.	

### 20.4.2 Service provided at the TMB-SAP

The TMB-SAP shall be used for the transfer of un-addressed system broadcast messages, which carry network or system organization information from the BS to the MS.

In the present document the LLC layer does not have any TMB-SAP related functions. The requests at the TLB-SAP are directly mapped as requests at the TMB-SAP and the indications at the TMB-SAP are directly transported to TLB-SAP indications. The service descriptions for the TLB-SAP are therefore valid for the TMB-SAP and are not repeated.

Table 300 shows these relationships at the TLB-SAP (MLE-LLC) and the TMB-SAP (LLC-MAC).

**Table 300: Correspondence between MAC and LLC at the TMB-SAP and TLB-SAP**

LLC Service Primitives (TLB-SAP)	MAC Service Primitive (TMB-SAP)	MAC Logical Channel (TMV-SAP)
TL-SYNC request, indication	TMB-SYNC request, indication	BSCH
TL-SYSINFO request, indication	TMB-SYSINFO request, indication	BNCH (SCH/HD)
NOTE: The received system synchronization and information messages in the MS are conveyed to the MLE via the LLC using the TxB-SAP. Parameters calculated when receiving broadcast information are conveyed using the TxC-SAP.		

### 20.4.3 Service provided at the TMC-SAP

The TMC-SAP shall be used for the transfer of local layer management information. It does not provide data transfer services over the air interface. The requests and responses at the TLC-SAP shall be directly mapped as requests and responses at the TMC-SAP and the indications and confirms at the TMC-SAP shall be directly transported to the TLC-SAP as indications and confirms. The service descriptions for the TLC-SAP are therefore valid for the TMC-SAP and are not repeated. The LLC also may use the TMC-CONFIGURE request primitive.

**TMC-CONFIGURE indication:** this primitive shall be used to indicate loss of lower layer resources. It may be used to indicate regain of lower layer resources. The parameters shall be as defined in table 300A.

**TMC-CONFIGURE request:** this primitive shall be used to accept or reject a channel change. The parameters shall be as defined in table 300A.

**Table 300A: Parameters used in the TMC-CONFIGURE request primitive**

Parameter	Request	Indication
Channel change handle (see note 1, see note 2)	C	-
Channel change accepted (see note 1, see note 2)	C	-
Endpoint identifier (see note 1)	-	M
Lower layer resource availability (see note 1)	-	M
NOTE 1: Not sent over the air interface.		
NOTE 2: These parameters are a subset of those TMC-CONFIGURE request parameters which are used when TL-CONFIGURE request is mapped into TMC-CONFIGURE request, refer to clause 20.3.5.4.1.		

Table 301 shows relationships at the TLC-SAP (MLE-LLC) and the TMC-SAP (LLC-MAC).

**Table 301: Correspondence between MAC and LLC at the TMC-SAP and TLC-SAP**

LLC service primitives (TLC-SAP)	MAC service primitive (TMC-SAP)
TL-CONFIGURE	TMC-CONFIGURE
TL-MEASUREMENT	TMC-MEASUREMENT
TL-MONITOR	TMC-MONITOR
TL-MONITOR-LIST	TMC-MONITOR-LIST
TL-REPORT	TMC-REPORT
TL-SCAN	TMC-SCAN
TL-SCAN-REPORT	TMC-SCAN-REPORT
TL-SELECT	TMC-SELECT

### 20.4.4 Service provided at the TMD-SAP

The TMD-SAP shall be used in the MS in circuit mode for the transfer of speech frames and/or synchronization information for end-to-end encryption purpose, and/or the transfer of data. It shall provide the interface between the MAC and the TETRA speech CODEC, and between the MAC and the other circuit mode applications.

The speech frames may contain either clear or end-to-end encrypted speech, but their actual information content (as also for data transported in circuit mode) is irrelevant to the MAC. Speech frames may be stolen by the MAC according to the parameter definition and the procedures as explained in clause 23. The same parameters may be used for circuit mode data.

Before transmission, speech frames and user data shall be coded and protected in the MAC in a way depending on whether they contain only speech or user data related information, one stolen half slot or two stolen half slots. Stolen half slots shall contain signalling information, either from C-plane or from U-plane (e.g. for end-to-end encryption synchronization).

For the purpose of the description in the rest of this clause, the unit of exchange at the TMD-SAP is always a half slot. Under normal circumstances in traffic mode, two primitive exchanges each containing the equivalent of half a slot capacity are required to fill the physical MAC block going to be transmitted over the air interface.

### 20.4.4.1 Service primitives and parameters at the TMD-SAP

#### 20.4.4.1.1 TMD-REPORT primitive

TMD-REPORT indication shall be used by the MAC to report on the progress of a request procedure. For example, it shall be used by the sending MAC to report to the U-plane application when the MAC has stolen traffic capacity.

The half slot synchronization shall be a parameter (or any local signal) that the MS MAC shall give internally to the U-plane application to enable a distinction between the first and the second half slot, i.e. a proper use of first half slot and second half parameters by the U-plane application. For the purpose of this description, a TMD-REPORT indication shall be sent before any TMD-UNITDATA request as an initial synchronization for the U-plane application.

The parameters shall be as defined in table 302.

**Table 302: Parameters used in the TMD-REPORT primitive**

Parameter	Indication (see note)
Half slot synchronization	C
TCH type and interleaving depth	C
number of slots per TDMA frame	C
end-to-end encryption flag	C
user device	C
Report	M
NOTE: Not sent over the air interface.	

#### 20.4.4.1.2 TMD-UNITDATA primitive

TMD-UNITDATA request shall be used to request the MAC to transmit one half slot.

TMD-UNITDATA indication shall be used by the MAC to deliver one half slot.

The parameters shall be as defined in table 303.

**Table 303: Parameters used in the TMD-UNITDATA primitive**

Parameter	Request	Indication
Half slot content	M	M
Half slot position (see note)	C	C
Half slot importance (see note)	M	-
Stolen indication	M	M
Half slot condition (see note)	-	M
User device (see note)	C	C
NOTE: Not sent over the air interface.		

NOTE: The half slot position may be implicit after the first synchronization phase.

The user device number shall identify the circuit which the information shall be transferred to, and from.

## 21 Layer 2 PDU description

This clause describes the PDUs for the V+D air interface at layer 2. An overview of the DLL architecture can be found in clause 19. The sub-layer interactions between MAC and LLC are described herein by the protocol elements.

This clause is intended to be read together with the MAC protocol clause 23 and LLC protocol clause 22. A detailed service description is provided in clause 20.

Binary values are indicated in this clause by a subscript 2, thus: 10110<sub>2</sub>.



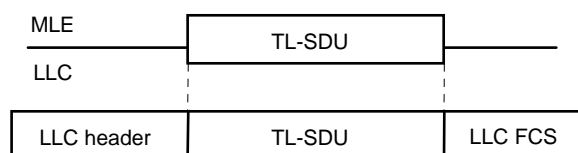
## 21.1 DLL PDU structure

### 21.1.1 DLL overhead

The DLL overhead contains independent LLC and MAC headers. Therefore, the following description distinguishes first LLC overhead and then MAC overhead. Overhead shall be added by a sub-layer independently of the overhead attached by the other sub-layer.

### 21.1.2 LLC PDUs structure

The LLC adds an LLC header to TL-SDUs to create LLC PDUs. The LLC PDU shall have the format illustrated in figure 93.



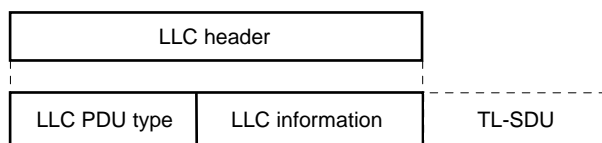
**Figure 93: Construction of an LLC PDU (shown with optional FCS)**

#### 21.1.2.1 LLC header

The LLC header discriminates between various PDUs, see table 304. The uses of the different LLC PDUs are specified in clause 22.

#### 21.1.2.2 Format of LLC header

The LLC PDU type illustrated in figure 94 is defined in clause 21.2.1. The LLC PDU type element shall have a length of 4 bits. The length of the LLC information structure depends on the PDU type.



**Figure 94: General format of an LLC header before the TL-SDU content**

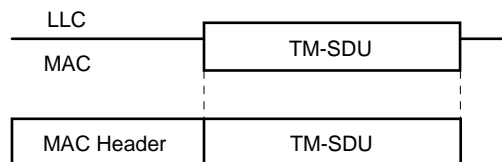
#### 21.1.2.3 LLC FCS

For the advanced link and on request for the basic link, the LLC shall calculate and add a FCS to the information being transmitted. Its size shall be 32 bits. This provides a Probability of Undetected Erroneous Message (PUEM) of about  $10^{-13}$  or better. This may be requested for packet data transmission whereas the MAC error detection mechanism (16 bits CRC) guarantees a PUEM of  $10^{-6}$  only. The LLC FCS shall be placed immediately after the end of the TL-SDU as shown in figure 93. The FCS as defined in clause 22 shall be used.

## 21.1.3 MAC PDUs structure

### 21.1.3.1 MAC overhead

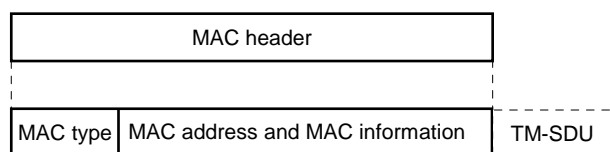
Each TM-SDU to be transmitted shall have a MAC header added as shown in figure 95.



**Figure 95: General format of the MAC PDU**

### 21.1.3.2 Format of the MAC header

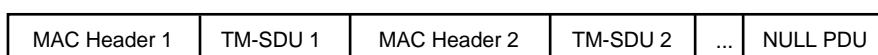
The MAC header enables the receiving MAC entity to identify the functions to be performed on the MAC PDU. The MAC type defines the structure of the MAC information. The MAC header shall have the format shown in figure 96.



**Figure 96: General format of a MAC header**

Generally, the MAC header shall contain three types of element, the MAC type, the MAC address and some MAC information. In order to keep the overhead as small as possible, continuations and the end of fragmented data (MAC-FRAG and MAC-END) shall not contain any address.

The MAC header structure enables the MAC to associate and transmit several independent MAC PDU in one MAC block. Unused bits should be filled with a NULL PDU as illustrated in figure 97, or fill bits may be used (not shown) (see clause 23).



**Figure 97: Association of several MAC PDU in one MAC block**

#### 21.1.3.2.1 MAC type

The MAC type enables to distinguish between the different PDU and the different SAP to which the receiving MAC should route the TM-SDU.

#### 21.1.3.2.2 MAC information

According to the MAC type, the location and format of MAC address and information is defined in the relevant MAC section.

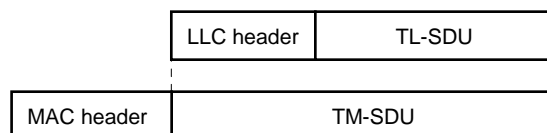
#### 21.1.3.2.3 MAC address

For the layer 2 addressing particularities, refer to EN 300 392-1 [9], clauses 7 and 23 of the present document.

## 21.1.4 DLL PDU building

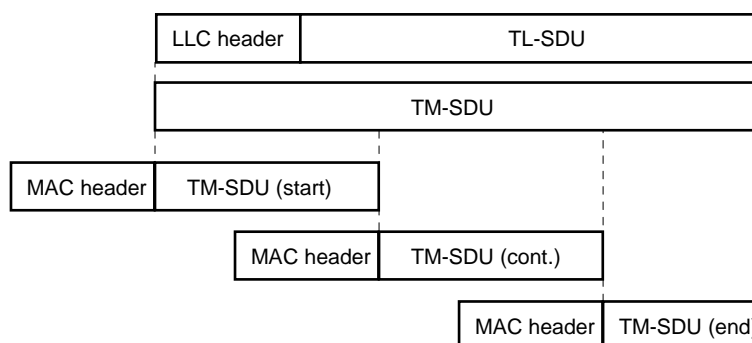
### 21.1.4.1 Basic link illustration

Figure 98 illustrates the method when a message (MAC header and TM-SDU) fits within the MAC block size.



**Figure 98: Building of DLL PDU (with no fragmentation)**

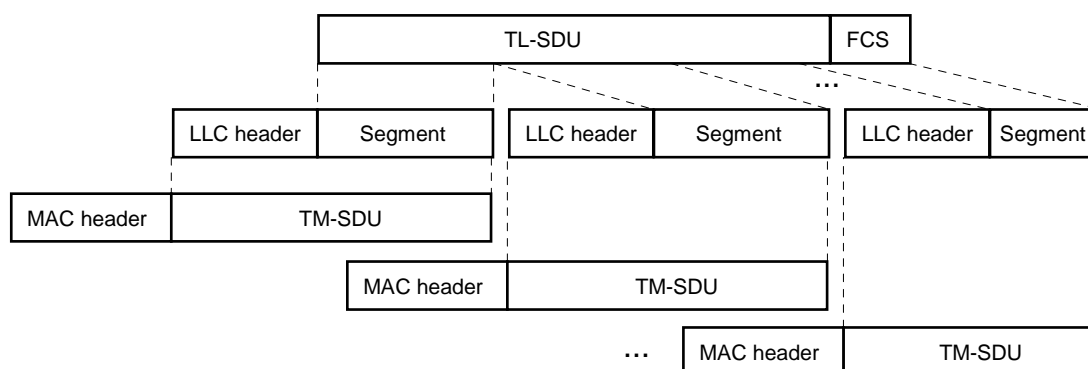
If the size of the TM-SDU exceeds the available capacity in a MAC block, MAC fragmentation shall occur as shown in figure 99.



**Figure 99: MAC fragmentation of a long TM-SDU**

Optionally, the LLC may add a FCS as part of the TM-SDU (This is not shown in figures 98 and 99, but is illustrated on figure 93). The whole TM-SDU contains only a single LLC header. Therefore, if an error occurs during transmission, the whole TM-SDU has to be re-transmitted. This is not the case for the advanced link illustrated in figure 100.

### 21.1.4.2 Advanced link illustration



**Figure 100: Segmentation provided by the advanced link**

As opposed to fragmentation performed by the MAC, LLC segmentation shall label each segment with a sent segment sequence number  $S(S)$  so that each of the segments shall be uniquely identified and used as the re-transmission unit (selective rejection applies under the advanced link, refer to clause 22). Figure 100 shows that each TM-SDU has its own LLC header in addition to the MAC header. The LLC shall add a FCS at the end of the last segment. This FCS shall be calculated over the entire TL-SDU.

## 21.1.5 PDU description format

The following clauses contain descriptions of the LLC and MAC protocol PDUs and the information elements contained in the PDUs. The structure of the PDU definitions represented by the tables is as follows:

- the information element column is the name of the element;
- the element length column defines the length of the element in bits;
- the element types (C/O/M) are:
  - Mandatory (M): this element shall always be present and shall appear in the order shown;
  - Optional (O): these elements are optional and if they are used, then they shall appear in the order shown;
  - Conditional (C): this element is conditional depending on another field before that element. If this is used, then it shall appear in the order shown.

NOTE: Unlike the layer 3 PDUs, layer 2 PDUs do not use any "O" bits or "P" bits to indicate the presence of optional fields. Whether or not optional fields are present in the PDU can be derived by context.

- the value column describe notes fixed values or a range of valid values. If this field is empty all bit combinations are valid;
- the remarks column defines meanings of the values or it may contain other information on the information element.

## 21.2 Logical Link Control (LLC) PDUs description

The information contained in the following PDU descriptions shall be read from top to bottom. The content within an information element shall start with the most significant bit (i.e. the leftmost bit shown in the information element descriptions) and shall continue until it reaches the least significant bit.

### 21.2.1 LLC PDU types

**Table 304: Definition of LLC PDU types**

LLC type	PDU associated
0000 <sub>2</sub>	BL-ADATA (without FCS)
0001 <sub>2</sub>	BL-DATA (without FCS)
0010 <sub>2</sub>	BL-UDATA (without FCS)
0011 <sub>2</sub>	BL-ACK (without FCS)
0100 <sub>2</sub>	BL-ADATA (with FCS)
0101 <sub>2</sub>	BL-DATA (with FCS)
0110 <sub>2</sub>	BL-UDATA (with FCS)
0111 <sub>2</sub>	BL-ACK (with FCS)
1000 <sub>2</sub>	AL-SETUP
1001 <sub>2</sub>	AL-DATA/AL-DATA-AR/AL-FINAL/AL-FINAL-AR
1010 <sub>2</sub>	AL-UDATA/AL-UFINAL
1011 <sub>2</sub>	AL-ACK/AL-RNR
1100 <sub>2</sub>	AL-RECONNECT
1101 <sub>2</sub>	Reserved
1110 <sub>2</sub>	Reserved
1111 <sub>2</sub>	AL-DISC

The PDU type field shall have a length of 4 bits. The PDU type values shall be according to table 304. The names reflect the functionality inside the LLC. PDUs having the same LLC type values are discriminated by additional information elements. Basic link PDUs start with prefix BL, advanced link PDUs start with prefix AL.

## 21.2.2 Basic link PDU definitions

The following 8 PDUs are defined for the basic link:

- BL-ACK without FCS for the acknowledgement of the previous transmission (BL-DATA or BL-ADATA);
- BL-ACK with FCS for the acknowledgement of the previous transmission (BL-DATA or BL-ADATA);
- BL-ADATA without FCS for acknowledgement and the transmission of acknowledged information;
- BL-ADATA with FCS for acknowledgement and the transmission of acknowledged information;
- BL-DATA without FCS for the transmission of acknowledged information;
- BL-DATA with FCS for the transmission of acknowledged information;
- BL-UDATA without FCS for the transmission of unacknowledged information;
- BL-UDATA with FCS for the transmission of unacknowledged information.

### 21.2.2.1 BL-ACK

- PDU: BL-ACK;
- service provided: acknowledgement and optional data transfer in basic link;
- response to: BL-DATA or BL-ADATA;
- response expected: none;
- short description: this PDU shall be used to acknowledge one TL-SDU. There are 2 PDUs defined, one without and another one with a FCS. The BL-ACK PDUs can carry service user data from a TL-DATA response primitive.

The elements of BL-ACK PDU without FCS shall be as defined in table 305.

The elements of BL-ACK PDU with FCS shall be as defined in table 306. This PDU shall be used only if a TL-SDU is present.

**Table 305: BL-ACK PDU without FCS contents**

Information element	Length	Type	Value	Remark
LLC PDU type	4	M	see table 304	
N(R)	1	M		Received TL-SDU number
TL-SDU	variable	O		Data from TL-DATA response primitive

**Table 306: BL-ACK PDU with FCS contents**

Information element	Length	Type	Value	Remark
LLC PDU type	4	M	see table 304	
N(R)	1	M		Received TL-SDU number
TL-SDU	variable	M		Data from TL-DATA response primitive
FCS	32	M		Frame Check Sequence

### 21.2.2.2 BL-ADATA

- PDU: BL-ADATA;
- service provided: basic link (acknowledged service in connectionless mode);
- response to: BL-DATA or BL-ADATA;
- response expected: BL-ADATA or BL-ACK.
- short description: there are two PDUs defined, one without and another one with FCS. These PDUs shall be used to acknowledge one TL-SDU and send acknowledged data.

The elements of BL-ADATA PDU without FCS shall be as defined in table 307.

The elements of BL-ADATA PDU with FCS shall be as defined in table 308.

**Table 307: BL-ADATA PDU without FCS contents**

Information element	Length	Type	Value	Remark
LLC PDU type	4	M	see table 304	
N(R)	1	M		Received TL-SDU number
N(S)	1	M		Sent TL-SDU number
TL-SDU	variable	M		Data from TL-DATA request primitive

**Table 308: BL-ADATA PDU with FCS contents**

Information element	Length	Type	Value	Remark
LLC PDU type	4	M	see table 304	
N(R)	1	M		Received TL-SDU number
N(S)	1	M		Sent TL-SDU number
TL-SDU	variable	M		Data from TL-DATA request primitive
FCS	32	M		Frame Check Sequence

### 21.2.2.3 BL-DATA

- PDU: BL-DATA;
- service provided: basic link (acknowledged service in connectionless mode);
- response to: -;
- response expected: BL-ACK or BL-ADATA;
- short description: there are two PDUs defined, one without and another one with FCS. These PDUs shall be used to send acknowledged data.

The elements of BL-DATA PDU without FCS shall be as defined in table 309.

The elements of BL-DATA PDU with FCS shall be as defined in table 310.

**Table 309: BL-DATA PDU without FCS contents**

Information element	Length	Type	Value	Remark
LLC PDU type	4	M	see table 304	
N(S)	1	M		Sent TL-SDU number
TL-SDU	variable	M		Data from TL-DATA request primitive

**Table 310: BL-DATA PDU with FCS contents**

Information element	Length	Type	Value	Remark
LLC PDU type	4	M	see table 304	
N(S)	1	M		Sent TL-SDU number
TL-SDU	variable	M		Data from TL-DATA request primitive
FCS	32	M		Frame Check Sequence

#### 21.2.2.4 BL-UDATA

- PDU: BL-UDATA;
- service provided: basic link (unacknowledged service in connectionless mode);
- response to: -;
- response expected: none;
- short description: these PDUs shall be used to send unacknowledged data. There are two separate PDU having a different LLC type to indicate whether the PDU contains the FCS or not.

The elements of BL-UDATA PDU without FCS shall be as defined in table 311.

The elements of BL-UDATA PDU with FCS shall be as defined in table 312.

**Table 311: BL-UDATA PDU without FCS contents**

Information element	Length	Type	Value	Remark
LLC PDU type	4	M	see table 304	
TL-SDU	variable	M		Data from TL-UNITDATA request primitive

**Table 312: BL-UDATA PDU with FCS contents**

Information element	Length	Type	Value	Remark
LLC PDU type	4	M	see table 304	
TL-SDU	variable	M		Data from TL-UNITDATA request primitive
FCS	32	M		Frame Check Sequence

#### 21.2.3 Advanced link PDU definitions

The advanced link uses 10 different PDUs:

- AL-ACK for an acknowledgement of received information with receive ready flow control indication;
- AL-RNR for an acknowledgement of received information with receive not ready flow control indication;
- AL-FINAL for transmission of the last segment of an acknowledged information;
- AL-FINAL-AR for transmission of the last segment of an acknowledged information with an acknowledgement request;
- AL-DATA for transmission of an acknowledged information segment;
- AL-DATA-AR for transmission of an acknowledged information segment with acknowledgement request;
- AL-DISC for disconnecting the advanced link;
- AL-SETUP for establishment or reset of the advanced link with quality of service negotiation;
- AL-RECONNECT for reconnection of an advanced link after cell reselection;

- AL-UDATA for transmission of a segment of an unacknowledged information;
- AL-UFINAL for transmission of the last segment of an unacknowledged information.

NOTE: The 11 different PDUs are presented by 6 different PDU types, see table 304.

AL-DATA or AL-DATA-AR shall never contain an entire FCS and shall not be used as the last segment of a TL-SDU, while AL-FINAL and AL-FINAL-AR shall always contain a FCS or the last part of it and shall be used as the last segment of a TL-SDU.

### 21.2.3.1 AL-ACK, AL-RNR

- PDU: AL-ACK (receiver ready with acknowledgement);
- AL-RNR (receiver not ready with acknowledgement);
- service provided: acknowledgement in advanced link (connection mode) flow control;
- response to: AL-DATA, AL-DATA-AR, AL-FINAL and AL-FINAL-AR;
- response expected: none;
- short description: these PDUs shall be used to acknowledge TL-SDUs and/or segments of TL-SDUs. They support flow control by reporting "receiver ready" or "receiver not ready" to the peer sender.

The elements of AL-ACK and AL-RNR PDUs shall be as defined in table 313.

**Table 313: AL-ACK and AL-RNR PDUs contents**

Information element	Length	Type	Value	Remark
LLC PDU type	4	M	see table 304	
Flow control	1	M	0	Receiver not ready (AL-RNR)
			1	Receiver ready (AL-ACK)
First Acknowledgement Block	variable	M		Acknowledgement of the eldest unacknowledged TL-SDU
Other Acknowledgement Blocks	variable	O		Acknowledgement of the next unacknowledged TL-SDUs, may be repeated up to window size N.272 (see note)
NOTE: When the maximum size of the TL-SDU is 4 096 octets an acknowledgement block may contain a continuation of the previous acknowledgement block, refer to note 4 in table 314.				



The acknowledgement block shall be as defined in table 314.

**Table 314: Acknowledgement block information element contents**

Information element	Length	Type	Value	Remark
N(R)	3	M		The number of the TL-SDU (see note 4)
Acknowledgement length	6	M	000000 <sub>2</sub>	SDU correctly received
			000001 <sub>2</sub>	Number of acknowledged segments
			...etc.	...etc.
			111110 <sub>2</sub>	Number of acknowledged segments
			111111 <sub>2</sub>	Repeat the entire SDU
S(R)	8 see note 1	C		Sequence number of the eldest not yet correctly received segment (see note 4)
Acknowledgement bit map	Variable see note 2 see note 3	C	0	Incorrectly or not yet received segment
			1	Correctly received segment
NOTE 1: The element is present if the acknowledgement length is in the range from 000001 <sub>2</sub> to 111110 <sub>2</sub> .				
NOTE 2: Length of the bitmap is variable, each bit is set as defined.				
NOTE 3: The element is present if the acknowledgement length is in the range from 000010 <sub>2</sub> to 111110 <sub>2</sub> . The length of the bitmap is acknowledgement length minus one.				
NOTE 4: When the maximum size of the TL-SDU is 4 096 octets an acknowledgement block may contain a continuation of the previous acknowledgement block and the N(R) shall indicate the same number of the TL-SDU as in the previous acknowledgement block and the S(R) shall indicate the sequence number of the eldest not yet correctly received segment after the segments indicated by the previous acknowledgement block.				

The correct reception of an entire TL-SDU shall be indicated by the acknowledgement length set to zero (000000<sub>2</sub>). A TL-SDU FCS failure shall be indicated by the acknowledgement length set to 111111<sub>2</sub> binary. In these cases the acknowledgement block shall not contain the fields S(R) and acknowledgement bit map.

In the other cases the total number of the acknowledged segments shall be equal to the number in the acknowledgement length field. The "total number of the acknowledgement segments" refers to the number of segments, which are incorporated into the acknowledgement PDU. In the case 000001<sub>2</sub> binary, only S(R) is present and the bitmap is empty. Because the segment indicated by S(R) is implicitly not acknowledged (not correctly received), the length of the bitmap is Acknowledgement length minus one. Acknowledgement bit map shall indicate the reception status (STATUS) of each segment starting from the next segment after the S(R) and moving forwards one segment at a time, up to the segment with the highest sequence number that has been correctly received or by the available room in the AL-ACK or AL-RNR PDU. The status of the segment shall be set to "1" if it is correctly received and to "0" if it is not correctly received. All segments prior to the one referred to by the S(R) shall be correctly received in the indicated TL-SDU except when two acknowledgement blocks refer to the same TL-SDU, see note 4 in table 314. When two acknowledgement blocks refer to the same TL-SDU in the same AL-ACK or AL-RNR PDU, there may be a range of correctly received segments between the segments indicated in the acknowledgement blocks. When the maximum size of the TL-SDU is 2 048 octets or less, then two acknowledgement blocks in the same AL-ACK or AL-RNR PDU shall not refer to the same TL-SDU.

For the sending entity the support of two acknowledgement blocks, which refer to the same TL-SDU in the same AL-ACK or AL-RNR PDU, is mandatory when it supports 4 096 octets as the maximum size of the TL-SDU.

NOTE: Instead of using two acknowledgement blocks which refer to the same TL-SDU in the same AL-ACK or AL-RNR PDU the acknowledging entity may wait for re-reception of the incorrectly received segments before including further segments into the acknowledgements.

The AL-ACK PDU may also contain acknowledgement for multiple TL-SDUs. The AL-ACK or AL-RNR PDU contains acknowledgement blocks up to the number of the SDUs in the window.

### 21.2.3.2 AL-FINAL, AL-FINAL-AR

- PDU: AL-FINAL (last data of a TL-SDU);
- AL-FINAL-AR (last data of a TL-SDU with immediate acknowledgement required);
- service provided: data transfer in advanced link (connection mode);
- response to: -;
- response expected: AL-ACK to the AL-FINAL-AR;
- short description: these PDUs shall be used to send the last segment in a TL-SDU or a whole TL-SDU. When an immediate response is required, AL-FINAL-AR shall be used.

The elements of AL-FINAL and AL-FINAL-AR PDUs shall be as defined in table 315.

**Table 315: AL-FINAL and AL-FINAL-AR PDUs contents**

Information element	Length	Type	Value	Remark
LLC PDU type	4	M	see table 304	
FINAL	1	M	1	Last segment with FCS
AR	1	M	0	No immediate response (AL-FINAL)
			1	Immediate response required (AL-FINAL-AR)
N(S)	3	M		Sent TL-SDU number
S(S)	8	M		Sent segment sequence number
The last segment of TL-DATA SDU	Variable see note 1	O		The last segment of TL-DATA SDU
FCS	32 see note 2	M		Frame Check Sequence
NOTE 1: This PDU may contain no data from the TL-DATA request primitive, see note 2.				
NOTE 2: The size shown is the upper limit of the FCS field, a part of the FCS could be in the previous AL-DATA PDU.				

### 21.2.3.3 AL-DATA, AL-DATA-AR

- PDU: AL-DATA (acknowledged information transfer);
- AL-DATA-AR (acknowledged information transfer with immediate response);
- service provided: data transfer in advanced link (connection mode);
- response to: -;
- response expected: AL-ACK to the AL-DATA-AR;
- short description: these PDUs shall be used to send all other segments than the last one of a TL-SDU. When the sending entity requests an immediate acknowledgement, AL-DATA-AR shall be used. For the transmission of the last segment see AL-FINAL/AL-FINAL-AR PDU.

The elements of AL-DATA and AL-DAT-AR PDUs shall be as defined in table 316.

**Table 316: AL-DATA and AL-DATA-AR PDUs contents**

Information element	Length	Type	Value	Remark
LLC PDU type	4	M	see table 304	
FINAL	1	M	0	Not the last segment
AR	1	M	0	No immediate response (AL-DATA)
			1	Immediate response required (AL-DATA-AR)
N(S)	3	M		Sent TL-SDU number
S(S)	8	M		Sent segment sequence number
Segment of TL-SDU	Varies	M		A segment of TL-SDU, The length depends on the MAC block used.

#### 21.2.3.4 AL-DISC

- PDU: AL-DISC (disconnection phase of the advanced link);
- service provided: disconnection of an advanced link (connection mode);
- response to: AL-DISC, see protocol definition for parameters;
- response expected: AL-DISC or none, see protocol definition for parameters;
- short description: this PDU is used to disconnect an advanced link.

The elements of AL-DISC PDU shall be as defined in table 317.

**Table 317: AL-DISC PDU contents**

Information element	Length	Type	Value	Remark
LLC PDU type	4	M	see table 304	
Advanced link service	1	M	0	Unacknowledged service
			1	Acknowledged service
Advanced link number	2	M	00 <sub>2</sub>	Advanced link number 1
			01 <sub>2</sub>	Advanced link number 2
			10 <sub>2</sub>	Advanced link number 3
			11 <sub>2</sub>	Advanced link number 4
Report	3	M	000 <sub>2</sub>	Success
			001 <sub>2</sub>	Close
			010 <sub>2</sub>	Reject
			011 <sub>2</sub>	Service not supported
			100 <sub>2</sub>	Service temporarily unavailable
			101 <sub>2</sub>	Reserved
			110 <sub>2</sub>	Reserved
111 <sub>2</sub>	Reserved			

The advanced link number is used locally between MS and BS to distinguish concurrent advanced links. The endpoint identifier in the MLE primitives is mapped against an advanced link number.

### 21.2.3.4a AL-RECONNECT

- PDU: AL-RECONNECT;
- service provided: reconnection of advanced link after cell reselection;
- response to: AL-RECONNECT, see protocol definition for parameters;
- response expected: AL-RECONNECT, see protocol definition for parameters;
- short description: this PDU is used to by the MS to request that the advanced link which was used on the previous cell is reconnected on the current cell and all the advanced link parameters are maintained.

The elements of AL-RECONNECT PDU shall be as defined in table 317a.

**Table 317a: AL-RECONNECT PDU contents**

Information element	Length	Type	Value	Remark
LLC PDU type	4	M	see table 304	
Advanced link service	1	M	0	Unacknowledged service (see note)
			1	Acknowledged service
Advanced link number N.261	2	M	00 <sub>2</sub>	Advanced link number 1
			01 <sub>2</sub>	Advanced link number 2
			10 <sub>2</sub>	Advanced link number 3
			11 <sub>2</sub>	Advanced link number 4
Reconnect report	2	M	00 <sub>2</sub>	Propose
			01 <sub>2</sub>	Reject
			10 <sub>2</sub>	Accept
			11 <sub>2</sub>	Reserved
NOTE: The present document does not support reconnection of an unacknowledged advanced link.				

### 21.2.3.5 AL-SETUP

- PDU: AL-SETUP (acknowledged or unacknowledged information containing advanced link set-up parameters);
- service provided: advanced link establishment or reset;
- response to: AL-SETUP in point-to-point case, see protocol;
- response expected: AL-SETUP or none in point-to-multipoint case, see protocol;
- short description: this PDU is used to establish the advanced link and to reset an established advanced link.

The elements of AL-SETUP PDU shall be as defined in table 318.

**Table 318: AL-SETUP PDU contents**

Information element	Length	Type	Value	Remark
LLC PDU type	4	M	see table 304	
Advanced link service	1	M	0	Unacknowledged service
			1	Acknowledged service
Advanced link number N.261	2	M	00 <sub>2</sub>	Advanced link number 1
			01 <sub>2</sub>	Advanced link number 2
			10 <sub>2</sub>	Advanced link number 3
			11 <sub>2</sub>	Advanced link number 4

Information element	Length	Type	Value	Remark
Maximum length of a TL-SDU N.271	3	M	000 <sub>2</sub>	32 octets
			001 <sub>2</sub>	64 octets
			010 <sub>2</sub>	128 octets
			011 <sub>2</sub>	256 octets
			100 <sub>2</sub>	512 octets
			101 <sub>2</sub>	1 024 octets
			110 <sub>2</sub>	2 048 octets
			111 <sub>2</sub>	4 096 octets
Connection width	1	M	0	Single slot connection
			1	Multislot connection
Advanced link symmetry	1	M	0	Symmetric advanced link
			1	Asymmetric advanced link
Number of timeslots used per TDMA frame on uplink or on uplink and downlink N.264 (see note 1)	2	C	00 <sub>2</sub>	1 timeslot
			01 <sub>2</sub>	2 timeslots
			10 <sub>2</sub>	3 timeslots
			11 <sub>2</sub>	4 timeslots
Number of timeslots used per TDMA frame on downlink N.264 (see note 2)	2	C	00 <sub>2</sub>	1 timeslot
			01 <sub>2</sub>	2 timeslots
			10 <sub>2</sub>	3 timeslots
			11 <sub>2</sub>	4 timeslots
Data transfer throughput (mean value) (see note 3)	3	M	000 <sub>2</sub>	Network dependent minimum
			001 <sub>2</sub>	1/32 of maximum
			010 <sub>2</sub>	1/16 of maximum
			011 <sub>2</sub>	1/8 of maximum
			100 <sub>2</sub>	1/4 of maximum
			101 <sub>2</sub>	1/2 of maximum
			110 <sub>2</sub>	Reserved
			111 <sub>2</sub>	Maximum
TL-SDU window size N.272 or N.281 (see note 4)	2	M	00 <sub>2</sub>	Reserved
			01 <sub>2</sub>	SDU window size = 1
			10 <sub>2</sub>	SDU window size = 2
			11 <sub>2</sub>	SDU window size = 3
Maximum number of TL-SDU retransmissions N.273 or TL-SDU repetition N.282 (see note 5)	3	M	000 <sub>22</sub>	no retransmissions
			001 <sub>2</sub>	1 re-transmission
			...etc.	...etc.
			111 <sub>2</sub>	7 retransmissions,

Information element	Length	Type	Value	Remark
Maximum number of segment retransmissions N.274	4	M	0000 <sub>2</sub>	no retransmissions
			0001 <sub>2</sub>	1 re-transmission
			...etc.	...etc.
			1111 <sub>2</sub>	15 retransmissions
Set-up report	3	M	000 <sub>2</sub>	Success
			001 <sub>2</sub>	Service definition
			010 <sub>2</sub>	Service change
			011 <sub>2</sub>	Reset
			100 <sub>2</sub>	Reserved
			101 <sub>2</sub>	Reserved
			110 <sub>2</sub>	Reserved
			111 <sub>2</sub>	Reserved
N(S) (see note 6)	8	C		Sent TL-SDU number
NOTE 1: This element shall be present only for the multislot connection (i.e. Connection width element set to "1"). In case of symmetric advanced link this element defines the number of timeslots used per TDMA frame both in uplink and downlink.				
NOTE 2: This element shall be present only for the multislot connection and asymmetric advanced link (i.e. Connection width element set to "1" and Connection symmetry element set to "1"). The usage of asymmetric advanced link is outside the scope of the present document.				
NOTE 3: The BS may use a control channel as a general packet data channel, supporting advanced links for many MSs, where each MS may be offering/receiving data packets at a low rate or intermittently. This parameter gives the BS the necessary information for planning its resource allocations.				
NOTE 4: TL-SDU window sizes N.272 and N.281 are for the acknowledged and unacknowledged services respectively.				
NOTE 5: For the acknowledged service the N.273 defines how many times the TL-SDU may be re-transmitted and for the unacknowledged (point-to-multipoint) service, N.282 means the number of times the TL-SDU will be repeated by the sender.				
NOTE 6: This element shall be present only for the unacknowledged service (i.e. advanced link service element set to "0").				

The advanced link number is used locally between MS and BS to distinguish concurrent advanced links. The endpoint identifier in the MLE primitives is mapped against an advanced link number.

The Data transfer throughput indicates how much of the total throughput of the allocated radio resources (timeslots) should be available for the advanced link. Maximum throughput will be realized when there is only one MS using the whole capacity of the radio resource allocation. The lower values indicate that the same radio resources may be used for multiple advanced links for one or more MS. The values are mean values and the usage allocation during the lifetime of an advanced link is outside of the scope of the present document.

### 21.2.3.6 AL-UDATA

- PDU: AL-UDATA (unacknowledged information transfer);
- service provided: unacknowledged data transfer in advanced link;
- response to: -;
- response expected: none;
- short description: this PDU is used to send one segment of unacknowledged TL-SDU.

The elements of AL-UDATA PDU shall be as defined in table 319.

**Table 319: AL-UDATA PDU contents**

Information element	Length	Type	Value	Remark
LLC PDU type	4	M	see table 304	
FINAL	1	M	0	Not the last segment
N(S)	8	M		Sent TL-SDU number
S(S)	8	M		Sent segment sequence number
Segment of TL-UNITDATA	Variable	M		Segment of TL-UNITDATA

### 21.2.3.7 AL-UFINAL

- PDU: AL-UFINAL (unacknowledged information transfer);
- service provided: data transfer in advanced link;
- response to: -;
- response expected: none;
- short description: this PDU is used to send the last segment of an unacknowledged TL-SDU in the advanced link in the downlink.

The elements of AL-UFINAL PDU shall be as defined in table 320.

**Table 320: AL-UFINAL PDU contents**

Information element	Length	Type	Value	Remark
LLC PDU type	4	M	see table 304	
FINAL	1	M	1	Last segment with FCS
N(S)	8	M		Sent TL-SDU number
S(S)	8	M		Sent segment sequence number
Last Segment of TL-UNITDATA	Variable see note 1	O		Last Segment of TL-UNITDATA
FCS	32 see note 2	M		FCS

NOTE 1: This PDU may contain no data from the TL-UNITDATA request primitive, see note 2.  
NOTE 2: The size shown is the upper limit of the FCS field, a part of the FCS could be in the previous AL-UDATA PDU.

## 21.3 LLC elements

### 21.3.1 FCS

This element is 32 bits long.

These bits shall be placed in decreasing order for the power of  $x$ . The co-efficient of  $x^{31}$  shall be mapped onto the most significant bit. The co-efficient of  $x^0$  shall be mapped onto the least significant bit. The FCS calculation is defined in clause 22.

### 21.3.2 TL-SDU size

In the various LLC PDU, one element often appears generally at the end of the PDU: start of TL-SDU. This indicates the beginning of the layer 3 information content which does not have a fixed length. Sometimes, this element is optional, which means that PDUs shall be exchanged even without layer 3 specific information. This is generally the case for responses, where the acknowledgement PDU is generated by the LLC and may be sent independently from the layer 3 message. On the other hand, the segments in an advanced link shall be calculated so that they fit in the MAC offered capacity.

## 21.4 MAC PDU description

The following clauses describe the information content of the MAC PDUs.

The information contained in the following PDU descriptions shall be read from left to right, starting at the top and going down. The information content shall start with the most significant bit and shall continue until it reaches the least significant bit.

A MAC PDU is composed of a MAC header and a TM-SDU which is passed to the MAC from the LLC layer. The MAC header contains information about the content of the PDU. One MAC block (either a half or full timeslot) may contain several independent MAC PDUs, each with their own header. The TM-SDU is transported by the MAC, but the MAC shall not have any visibility or knowledge of the SDU content.

### 21.4.1 MAC PDU types

These MAC PDU types as shown in table 321 shall be used for C-plane signalling messages, C-plane broadcast messages and end-to-end U-plane signalling.

**Table 321: MAC PDU types for SCH/F, SCH/HD and STCH**

Information element	Length	Type	Value	Remark
PDU type	2	M	00 <sub>2</sub>	TMA-SAP: MAC-DATA or MAC-RESOURCE
			01 <sub>2</sub>	TMA-SAP: MAC-END or MAC-FRAG
			10 <sub>2</sub>	TMB-SAP: Broadcast
			11 <sub>2</sub>	TMD-SAP: MAC-U-SIGNAL (U-plane signalling)

The PDU types shown in table 321 may be used for the transmission of signalling information in full slots on the uplink and downlink and in half slots on the downlink. Under normal operation, the MS shall use MAC-DATA for transmission on the uplink and the BS shall use MAC-RESOURCE for transmission on the downlink. MAC-FRAG and MAC-END shall be used on the uplink and downlink for transmission of continuations and end of a fragmented SDU. Three types of broadcast PDU are defined, namely SYNC, SYSINFO and ACCESS-DEFINE. These PDUs shall be used by the BS to transmit broadcast information on the downlink. MAC-U-SIGNAL shall be used by both MS and BS for the transmission of U-plane signalling information.

**Table 322: MAC PDU Types for SCH/HU**

Information element	Length	Type	Value	Remark
PDU type	1	M	0	TMA-SAP: MAC-ACCESS
			1	TMA-SAP: MAC-END-HU

The PDU types shown in table 322 may be used for the transmission of signalling information in half slots (i.e. subslots) on the uplink. The half slot signalling channel on the uplink may be recognized by a particular training sequence. The MS may transmit signalling information on the half slot uplink using the MAC-ACCESS PDU. The MS may also use the MAC-END-HU PDU for transmission of the end of a fragmented SDU.

The following clauses describe the contents of each of these uplink, downlink and broadcast PDUs.



## 21.4.2 TMA-SAP: MAC PDU structure for the uplink

The following clauses describe the MAC PDUs which may be sent on the uplink and which contain C-plane signalling information from the TMA-SAP in the MS.

### 21.4.2.1 MAC-ACCESS

This PDU may be used to send C-plane signalling data on the uplink in a subslot (SCH/HU). It shall be used for random access and may also be used for reserved access in a subslot. Its contents shall be as shown in table 323.

**Table 323: MAC-ACCESS PDU contents**

Information element	Length	Type	Value	Remark
PDU type	1	M	0	MAC-ACCESS
Fill bit indication	1	M	0	No fill bits present
			1	Fill bit(s) present
Encrypted flag	1	M	0	Not Encrypted
			1	Encrypted
Address type	2	M	00 <sub>2</sub>	SSI
			01 <sub>2</sub>	Event Label (address length 10, see note)
			10 <sub>2</sub>	USSI (migrating MS un-exchanged address)
			11 <sub>2</sub>	SMI (management address)
Address	24/10	M		SSI, USSI, SMI or Event Label according to address type
Optional field flag	1	M	0	No length indication nor capacity request
			1	Length indication or capacity request
Length indication or capacity request	1	C	0	Length indication
			1	Capacity request (i.e. fragmentation flag + reservation requirement)
Length indication	5	C	00000 <sub>2</sub>	Null PDU
			00001 <sub>2</sub>	Reserved
			00010 <sub>2</sub>	Reserved
			00011 <sub>2</sub>	Length of MAC PDU in octets
			...etc.	...etc.
			01100 <sub>2</sub>	Longest MAC-PDU
			01101 <sub>2</sub>	Reserved
			11111 <sub>2</sub>	Reserved
Fragmentation flag	1	C	0	TM-SDU not fragmented
			1	Start of fragmentation
Reservation requirement	4	C		see reservation requirement element definition
TM-SDU	varies	C		

NOTE: The address length of the other address types is 24.

The SCH/HU is distinguished by a particular training sequence. The first bit of the MAC header distinguishes between the two possible PDU types which can be sent on SCH/HU.

The fill bit indication shall indicate if there are any fill bits, which shall be added whenever the size of the TM-SDU is less than the available capacity of the SCH/HU MAC block or less than the size of the TM-SDU indicated by the length indication field. The TM-SDU length is equal to the MAC PDU length minus the MAC PDU header length.

The encrypted flag shall indicate whether or not the TM-SDU contents are encrypted. The MAC header shall not be encrypted but an alias stream may be used to encrypt the address. In the case of fragmentation, the setting of the encrypted flag in the MAC-ACCESS PDU shall apply to all fragments of that TM-SDU.

The address type field shall indicate the type of address contained in the address field. The length of the address field shall be 10 bits for an event label or 24 bits for SSI, USSI or SMI.

The optional field flag shall indicate whether any of the optional fields are present in the PDU header. If optional fields are present the next bit (length indication or capacity request) shall indicate whether the header contains a length indication field or a capacity request field. If length indication is indicated, then the next field shall be length indication. Length indication shall refer to the length of the MAC PDU (which comprises the MAC PDU header and the TM-SDU) and should be used only if association within the uplink half slot is required or for transmission of the null PDU.

The header length of a MAC-ACCESS PDU depends on the type of address in use and whether or not there is a length indication or capacity request. The header length and maximum TM-SDU length is shown in table 325 for each of the possible combinations.

The length indication field may be used to indicate a null PDU. If a null PDU is indicated, there shall be no further information in the PDU after the length indication field. The length of the null PDU, therefore, shall be 22 bits if an event label is used as an address or 36 bits if an SSI, USSI or SMI is used as an address. The null PDU, if it appears in a MAC block, shall always be the last PDU in that block. Any spare capacity after the null PDU shall be filled with fill bits.

**Table 324: Length of MAC-ACCESS PDU header and SDU**

Content of Header Fields	Header Length [bits]	Maximum TM-SDU Length [bits]
Address = Event Label No length indication nor capacity request	16	76
Address = SSI, USSI or SMI No length indication nor capacity request	30	62
Address = Event Label Length indication or capacity request	22	70
Address = SSI, USSI or SMI Length indication or capacity request	36	56

If capacity request is indicated in the length indication or capacity request bit, the next field shall be fragmentation flag followed by reservation requirement. Capacity request shall be used when the MS has further signalling to send, which may or may not be subsequent fragments of a fragmented SDU (as indicated by the fragmentation flag). The PDU may only contain either the length indication field or the capacity request field (comprising fragmentation flag and reservation requirement), but not both.

NOTE 1: An MS generally sets the "Optional field flag" to "1" only for transmission of the Null PDU or if PDU association is required within the subslot or if the MS has further signalling messages ready to be sent. Otherwise the flag is set to "0" giving a maximum TM-SDU length of 62 bits (or 76 bits if an event label is used).

NOTE 2: The "Optional field flag" is provided in the PDU in order to economize on the use of bits for the most usual cases. It is not provided in the MAC-END-HU, MAC-DATA or MAC-END PDUs, in which the size constraint is less critical.

NOTE 3: For example, the defined structure of the MAC-ACCESS PDU allows the CMCE U-SETUP PDU to be sent within a subslot, provided that:

- (a) the full TSI of the called party is not needed in the U-SETUP PDU; and
- (b) the FCS is not added by the LLC; and
- (c) the MAC does not include a capacity request so that the optional field flag = "0" (or an event label is used for addressing).

### 21.4.2.2 MAC-END-HU

This PDU shall be used to send the last fragment of fragmented C-plane signalling data on the uplink using a subslot (SCH/HU). Its contents shall be as shown in table 325.

**Table 325: MAC-END-HU PDU contents**

Information element	Length	Type	Value	Remark
PDU type	1	M	1	MAC-END-HU
Fill bit indication	1	M	0	No fill bits present
			1	Fill bit(s) present
Length indication or capacity request	1	M	0	Length indication
			1	Reservation requirement (i.e. Capacity request)
Length indication	4	C	0000 <sub>2</sub>	Reserved
			0001 <sub>2</sub>	Length of PDU in octets
			...etc.	...etc.
			1100 <sub>2</sub>	Longest PDU
			1101 <sub>2</sub>	Reserved
			1110 <sub>2</sub>	Reserved
1111 <sub>2</sub>	Reserved			
Reservation requirement	4	C		see reservation requirement element definition
TM-SDU	varies	C		

The SCH/HU is distinguished by a particular training sequence. The first bit of the MAC header distinguishes between the two possible PDU types which can be sent on SCH/HU.

The fill bit indication shall indicate if there are any fill bits, which shall be added whenever the size of the TM-SDU is less than the available capacity of the SCH/HU or less than the size of the TM-SDU indicated by the length indication field. The TM-SDU length is equal to the MAC PDU length minus the MAC PDU header length.

The length indication or capacity request field shall indicate whether the header contains a length indication field or a capacity request field. If length indication is indicated, then the next field shall be length indication. Length indication shall refer to the length of the MAC PDU which comprises the MAC PDU header and the TM-SDU. The length indicator shall be used if association within the uplink half slot is required or if the MS has no further signalling to send. If reservation requirement is indicated, the next field shall be reservation requirement which shall be used when the MS has further C-plane signalling messages ready to send. In that case the length of the TM-SDU is defined by the fill bit mechanism. The PDU may only contain either the length indication field or the reservation requirement field.

The header length of a MAC-END-HU PDU shall be equal to 7 bits. So the length of the TM-SDU shall not exceed 85 bits.

### 21.4.2.3 MAC-DATA

This PDU may be used to send C-plane signalling data on the uplink in a full slot (SCH/F). It may also be used to send C-plane signalling data in the first half of a full uplink slot using the stealing channel (STCH). If the second half of a full uplink slot is also stolen, the MAC-DATA PDU may be used to send another C-plane PDU in the second half slot. Its contents shall be as shown in table 326.

**Table 326: MAC-DATA PDU contents**

Information element	Length	Type	Value	Remark
PDU type	2	M	00 <sub>2</sub>	MAC-DATA
Fill bit indication	1	M	0	No fill bit present
			1	Fill bit(s) present
Encrypted flag	1	M	0	Not encrypted
			1	Encrypted
Address type	2	M	00 <sub>2</sub>	SSI
			01 <sub>2</sub>	Event Label (address length 10, see note)
			10 <sub>2</sub>	USSI (migrating MS un-exchanged address)
			11 <sub>2</sub>	SMI (management address)
Address	24/10	M		SSI, USSI, SMI or Event Label according to address type
Length indication or Capacity request	1	M	0	Length indication
			1	Capacity request (i.e. fragmentation flag + reservation requirement + reserved bit)
Length indication	6	C	000000 <sub>2</sub>	Null PDU
			000001 <sub>2</sub>	Reserved
			000010 <sub>2</sub>	Reserved
			000011 <sub>2</sub>	Length of MAC PDU in octets
			...etc.	...etc.
			100010 <sub>2</sub>	Longest MAC PDU
			100011 <sub>2</sub>	Reserved
			...etc.	...etc.
			111101 <sub>2</sub>	Reserved
			111110 <sub>2</sub>	Second half slot stolen on STCH
111111 <sub>2</sub>	Start of fragmentation on STCH			
Fragmentation flag	1	C	0	TM-SDU not fragmented
			1	Start of fragmentation
Reservation requirement	4	C		see reservation requirement element definition
Reserved	1	C	0	Default Value
			1	Not used in the present document
TM-SDU	varies	C		

NOTE: The address length of the other address types is 24.

The first two bits of the MAC header distinguish between the possible PDU types which can be sent on the uplink SCH/F or STCH.

The fill bit indication shall indicate if there are any fill bits, which shall be added whenever the size of the TM-SDU is less than the available capacity of the MAC block or less than the size of the TM-SDU indicated by the length indication field. The TM-SDU length is equal to the MAC PDU length minus the MAC PDU header length.

The encrypted flag shall indicate whether or not the TM-SDU contents are encrypted. The MAC header shall not be encrypted but an alias stream may be used to encrypt the address. In the case of fragmentation, the setting of the encrypted flag in the MAC-DATA PDU applies to all fragments of the TM-SDU.

The address type field shall indicate the type of address contained in the address field. The length of the address field shall be 10 bits for an event label or 24 bits for SSI, USSI or SMI.

The length indication or capacity request field shall indicate whether the header contains a length indication field or a capacity request field. If length indication is indicated, then the next field shall be length indication. Length indication shall refer to the length of the MAC PDU (which comprises the MAC PDU header and the TM-SDU) and shall be used if association is required or if the MS has no further signalling to send. If capacity request is indicated, the next field shall be fragmentation flag followed by reservation requirement and the reserved bit. Capacity request shall be used on SCH/F when the MS has further signalling to send, which may or may not be subsequent fragments of a fragmented SDU (as indicated by the fragmentation flag). The PDU may only contain either the length indication field or the capacity request field (comprising fragmentation flag, reservation requirement and the reserved bit).

The header length of a MAC-DATA PDU depends on the type of address in use. It shall be 37 bits when an SSI, USSI or SMI is used and 23 bits when an event label is used. So the length of the TM-SDU shall not exceed 231 bits and 245 bits respectively. The length indicated in the MAC PDU header shall refer to the entire MAC PDU which comprises the MAC PDU header and the TM-SDU.

The length indication field may be used to indicate a null PDU. If a null PDU is indicated, there shall be no further information in the PDU after the length indication field. The length of the null PDU, therefore, shall be 23 bits if an event label is used as an address or 37 bits if an SSI, USSI or SMI is used as an address. After a null PDU, there shall be no further PDUs in the MAC block and the remaining capacity shall contain fill bits.

This MAC-DATA PDU shall also be used for C-plane signalling using the STCH on the uplink. By default, the STCH occupies only the first half slot. The maximum length of the TM-SDU for a half slot on the uplink using the STCH shall be 87 bits when an SSI, USSI or SMI is used or 101 bits when an event label is used. The second half slot may also be stolen, either for the last fragment of a fragmented SDU or for subsequent PDUs which the MAC may have ready to send or for U-plane signalling. A length indication of "11111<sub>2</sub>" shall be used to indicate that the second half slot is stolen for the last fragment of a fragmented SDU. A length indication of "11110<sub>2</sub>" shall be used to indicate that the second half slot is stolen for subsequent C-plane signalling or U-plane signalling. The last fragment shall use the MAC-END PDU while subsequent C-plane PDUs shall use the MAC-DATA PDU and U-plane signalling shall use the MAC-U-SIGNAL PDU. It shall only be possible to fragment SDUs over the two halves of a full slot on the STCH.

#### 21.4.2.4 MAC-FRAG (uplink)

This PDU shall be used to send continuation fragments of fragmented C-plane signalling data on the uplink using a full slot (SCH/F). Its contents shall be as shown in table 327.

**Table 327: MAC-FRAG (uplink) PDU contents**

Information element	Length	Type	Value	Remark
PDU type	2	M	01 <sub>2</sub>	MAC-FRAG or MAC-END
PDU subtype	1	M	0	MAC-FRAG
Fill bit indication	1	M	0	No fill bits present
			1	Fill bit(s) present
TM-SDU	varies	M		

The first two bits of the MAC header distinguish between the possible PDU types which can be sent on the uplink using a full slot. A PDU subtype bit distinguishes between MAC-FRAG and MAC-END which share the same PDU type.

The fill bit indication shall indicate if there are any fill bits which shall be added whenever the size of the TM-SDU fragment is less than the available capacity of a full slot. Fill bits may be required for this PDU because the MAC-END header length is greater than the header length of this PDU. This means that it is possible that the last fragment of an SDU may be too large to fit into a MAC-END PDU but too small to fill the maximum TM-SDU space available in the MAC-FRAG PDU. In this case, fill bits are required in the MAC-FRAG PDU and MAC-END shall be sent with a zero-length TM-SDU.

The header length of a MAC-FRAG shall be equal to 4 bits. So the maximum length of the TM-SDU field shall be 264 bits.

### 21.4.2.5 MAC-END (uplink)

This PDU shall be used to send the last fragment of fragmented C-plane signalling data on the uplink using a full slot (SCH/F). It shall also be used to send the last fragment of fragmented C-plane signalling in the second half of a stolen full slot on the uplink. Its contents shall be as shown in table 328.

**Table 328: MAC-END (uplink) PDU contents**

Information element	Length	Type	Value	Remark
PDU type	2	M	01 <sub>2</sub>	MAC-FRAG or MAC-END
PDU subtype	1	M	1	MAC-END
Fill bit indication	1	M	0	No fill bits present
			1	Fill bit(s) present
Length indication / reservation requirement	6	M	000000 <sub>2</sub>	Reserved
			000001 <sub>2</sub>	Reserved
			000010 <sub>2</sub>	Length of MAC PDU in octets
			...etc.	...etc.
			100010 <sub>2</sub>	Longest MAC PDU
			100011 <sub>2</sub>	Reserved
			...etc.	...etc.
			101111 <sub>2</sub>	Reserved
11XXXX <sub>2</sub>	See reservation requirement element definition			
TM-SDU	varies	C		

The first two bits of the MAC header distinguish between the possible PDU types which can be sent on the uplink SCH/F or STCH. A PDU subtype bit distinguishes between MAC-FRAG and MAC-END which share the same PDU type.

The fill bit indication shall indicate if there are any fill bits, which shall be added whenever the size of the PDU is less than the available capacity of the MAC block or less than the size of the PDU indicated by the length indication field. The TM-SDU length is equal to the MAC PDU length minus the MAC PDU header length.

The next 6 bit field shall indicate length indication or a reservation requirement. A value from "000010<sub>2</sub>" to "100010<sub>2</sub>" shall indicate the length of the PDU. A value beginning with "11<sub>2</sub>" shall indicate a reservation requirement which shall be used on SCH/F when the MS has further C-plane signalling to send. The reservation requirement information is contained in the 4 least significant bits of these values, the meaning of which is given in the reservation requirement element definition.

The header length of a MAC-END PDU shall be equal to 10 bits. So the length of the TM-SDU shall not exceed 258 bits or 114 bits, when SCH/F or STCH is used respectively. The length indicated in the MAC PDU header shall refer to the MAC PDU which comprises the MAC PDU header and the TM-SDU.

### 21.4.3 TMA-SAP: MAC PDU structure for the downlink

The following clauses describe the MAC PDUs which may sent on the downlink and which contain C-plane signalling information for the TMA-SAP in the MS.

### 21.4.3.1 MAC-RESOURCE

This PDU may be used to send C-plane signalling data on the downlink in a full slot (SCH/F) or in the first or second half slot of a full slot (SCH/HD). It may also be used to send C-plane signalling data in the first half of a downlink slot using the Stealing Channel (STCH). If the second half of a downlink slot is also stolen, the MAC-RESOURCE PDU may be used to send another PDU in the second half slot.

This PDU may be sent without a TM-SDU in order to allocate uplink capacity, send a channel allocation or control mobile transmit power. Its contents shall be as shown in table 329.

**Table 329: MAC-RESOURCE PDU contents**

Information element	Length	Type	Value	Remark
PDU type	2	M	00 <sub>2</sub>	MAC-RESOURCE
Fill bit indication	1	M	0	No fill bits present
			1	Fill bit(s) present
Position of grant	1	M	0	Slot grant (if any) is on current channel
			1	Slot grant (if any) is on allocated channel
Encryption mode	2	M	00 <sub>2</sub>	Not encrypted
			01 <sub>2</sub>	See EN 300 392-7 [11]
			10 <sub>2</sub>	See EN 300 392-7 [11]
			11 <sub>2</sub>	See EN 300 392-7 [11]
Random access flag	1	M	0	Undefined
			1	Random Access Acknowledged
Length indication	6	M	000000 <sub>2</sub>	Reserved
			000001 <sub>2</sub>	Reserved
			000010 <sub>2</sub>	Length for null PDU
			000011 <sub>2</sub>	Reserved
			000100 <sub>2</sub>	Length of MAC PDU in octets
			...etc.	...etc.
			100010 <sub>2</sub>	Longest MAC PDU in octets
			100011 <sub>2</sub>	Reserved
			...etc.	...etc.
			111101 <sub>2</sub>	Reserved
			111110 <sub>2</sub>	Second half slot stolen in STCH
111111 <sub>2</sub>	Start of fragmentation			
Address type	3	M	000 <sub>2</sub>	Null PDU
			001 <sub>2</sub>	SSI
			010 <sub>2</sub>	Event Label
			011 <sub>2</sub>	USSI (migrating MS un-exchanged address)
			100 <sub>2</sub>	SMI (management address)
			101 <sub>2</sub>	SSI + Event Label (event label assignment)
			110 <sub>2</sub>	SSI + Usage Marker (usage marker assignment)
			111 <sub>2</sub>	SMI + Event Label (event label assignment)
Address	34/ 30/ 24/ 10	M		SSI/SMI + Event Label SSI + Usage Marker SSI, USSI or SMI Event Label
Power control flag	1	M	0	No power control element in PDU
			1	Power control element in PDU
Power control element	4	C		see power control element definition
Slot granting flag	1	M	0	No slot granting elements in PDU
			1	Slot granting element in PDU
Slot granting element	8	C		see slot granting element definition
Channel allocation flag	1	M	0	No channel allocation element in PDU
			1	Channel allocation element in PDU
Channel allocation element	variable	C		see channel allocation element definition
TM-SDU	variable	C		

The first two bits of the MAC header distinguish between the possible PDU types which can be sent in the downlink MAC block.

The fill bit indication shall indicate if there are any fill bits, which shall be added whenever the size of the TM-SDU is less than the available capacity of the MAC block or less than the size of the TM-SDU indicated by the length indication field. The TM-SDU length is equal to the MAC PDU length minus the MAC PDU header length.

The position of grant element indicates the channel on which the optional slot grant is valid. If there is no slot granting in this PDU, the MAC shall ignore the content of this bit.

The encrypted mode field shall indicate whether or not the TM-SDU contents are encrypted and, if so, the encryption algorithm used. Only the channel allocation element in the MAC header may be encrypted and an alias stream may be used to encrypt the address. In the case of fragmentation, the setting of the encrypted mode field in the MAC-RESOURCE PDU shall apply to all fragments of the TM-SDU.

The random access flag shall be used for the BS to acknowledge a successful random access so as to prevent the MS sending further random access requests.

The length indication field shall indicate the length of the MAC PDU which comprises the MAC PDU header and the TM-SDU. If the length indication field has value of "11111<sub>2</sub>", then this shall indicate the beginning of a fragmented signalling message.

The address type field shall indicate the type of address(es) contained in the address field. The length of the address field shall be 10 bits, 24 bits, 30 bits or 34 bits depending on the type of address information contained in it.

The power control flag shall indicate whether the optional power control element is present in this PDU. The slot granting flag shall indicate whether the optional slot granting element is present in this PDU. The channel allocation flag shall indicate whether the optional channel allocation element is present in this PDU.

The header length of a MAC-RESOURCE PDU depends on the type of address information and on which of the optional fields are present. The minimum length shall be 29 bits when an event label is used and there are no optional fields present. So the length of the TM-SDU shall not exceed 239 bits or 95 bits, when SCH/F or SCH/HD is used respectively. The length indicated in the MAC PDU header shall refer to the MAC PDU which comprises the MAC PDU header and the TM-SDU.

The address type field may be used to indicate a null PDU (address type = "000<sub>2</sub>"). If a null PDU is indicated, there shall be no further information in the PDU after the address type field. The length of the null PDU, therefore, shall be 16 bits. On STCH, the length indication field may indicate whether the second half slot is stolen. All other fields in a null PDU (i.e. Fill bit indication, Position of grant, Encryption mode, and Random access flag) may be set to any value by the BS and shall be ignored by the MS in the present document). If the null PDU is present in a MAC block, then there shall be no subsequent PDUs in that block and any spare capacity shall be filled with fill bits.

This PDU shall also be used for C-plane signalling using the STCH on the downlink. By default, the STCH occupies only the first half slot. The maximum length of the TM-SDU for a half slot on the downlink using the STCH shall be 95 bits when an event label is used. The second half slot may also be stolen, either for the last fragment of a fragmented SDU or for subsequent PDUs which the MAC may have ready to send or for U-plane signalling. A length indication of "11111<sub>2</sub>" shall be used to indicate that the second half slot is stolen for the last fragment of a fragmented SDU. A length indication of "11110<sub>2</sub>" shall be used to indicate that the second half slot is stolen for subsequent C-plane signalling or U-plane signalling. The last fragment shall use the MAC-END PDU while subsequent C-plane PDUs shall use the MAC-RESOURCE PDU and U-plane signalling shall use the MAC-U-SIGNAL PDU. It shall only be possible to fragment SDUs over the two halves of a full slot on the STCH.

### 21.4.3.2 MAC-FRAG (downlink)

This PDU shall be used to send continuation fragments of fragmented C-plane signalling data on the downlink using half slot (SCH/HD) or full slot (SCH/F) signalling. Its contents shall be as shown in table 330.



**Table 330: MAC-FRAG (downlink) PDU contents**

Information element	Length	Type	Value	Remark
PDU type	2	M	01 <sub>2</sub>	MAC-FRAG or MAC-END
PDU subtype	1	M	0	MAC-FRAG
Fill bit indication	1	M	0	No fill bits present
			1	Fill bit(s) present
TM-SDU	varies	M		

The first two bits of the MAC header distinguish between the possible PDU types which can be sent on the downlink. A PDU subtype bit distinguishes between MAC-FRAG and MAC-END which share the same PDU type.

The fill bit indication shall indicate if there are any fill bits, which shall be added whenever the size of the TM-SDU is less than the available capacity of the MAC block.

The header length of a MAC-FRAG PDU shall be equal to 4 bits. So the length of the TM-SDU shall not exceed 264 bits or 120 bits, when SCH/F or SCH/HD is used respectively.

### 21.4.3.3 MAC-END (downlink)

This PDU shall be used to send the last fragment of fragmented C-plane signalling data on the downlink in a full slot (SCH/F) or the first or second half of a full slot (SCH/HD). It shall also be used to send the last fragment of fragmented C-plane signalling in the second half of a stolen full slot on the downlink. Its contents shall be as shown in table 331.

**Table 331: MAC-END (downlink) PDU contents**

Information element	Length	Type	Value	Remark
PDU type	2	M	01 <sub>2</sub>	MAC-FRAG or MAC-END
PDU subtype	1	M	1	MAC-END
Fill bit indication	1	M	0	No fill bits present
			1	Fill bit(s) present
Position of grant	1	M	0	Slot grant is on current channel
			1	Slot grant is on allocated channel
Length indication	6	M	000000 <sub>2</sub>	Reserved
			000001 <sub>2</sub>	Reserved
			000010 <sub>2</sub>	Length of MAC PDU in octets
			...etc.	...etc.
			100010 <sub>2</sub>	Longest MAC PDU
			100011 <sub>2</sub>	Reserved
			...etc.	...etc.
Slot granting flag	1	M	0	No slot granting elements in PDU
			1	Slot granting element in PDU
Slot granting element	8	C		see slot granting element definition
Channel allocation Flag	1	M	0	No channel allocation element in PDU
			1	Channel allocation element in PDU
Channel allocation element	varies	C		see channel allocation element definition
TM-SDU	varies	C		

The first two bits of the MAC header shall distinguish between the possible PDU types which can be sent on the downlink. A PDU subtype bit distinguishes between MAC-FRAG and MAC-END which share the same PDU type.

The fill bit indication shall indicate if there are any fill bits, which shall be added whenever the size of the TM-SDU is less than the available capacity of the MAC block or less than the size of the TM-SDU indicated by the length indication field. The TM-SDU length is equal to the MAC PDU length minus the MAC PDU header length.

The position of grant element indicates the channel on which the optional slot grant is valid. If there is no slot granting in this PDU, the MAC shall ignore contents of this bit.

The length indication field shall indicate the length of the MAC PDU which comprises the MAC PDU header and the TM-SDU.

The slot granting flag shall indicate whether the slot granting element is contained in this PDU. The slot granting element may be used to allocate some uplink reserved slots for an MS.

The channel allocation flag shall indicate whether the channel allocation element is contained in this PDU. The channel allocation element may be used to direct MS to a channel at the end of a fragmented downlink message.

The minimum header length of a MAC-END PDU shall be equal to 13 bits. So the length of the TM-SDU shall not exceed 255 bits or 111 bits, when SCH/F or either SCH/HD or STCH is used. The length indicated in the MAC PDU header shall refer to the MAC PDU which comprises the MAC PDU header and the TM-SDU.

#### 21.4.4 TMB-SAP: MAC PDU structure for broadcast

Broadcast PDUs shall be used by the BS to send some broadcast information on the downlink to all MS. There shall be no addresses contained in these PDUs and all MS shall decode them as if they were addressed to each of them. The SYNC PDU shall be transmitted using the BSCH which shall be sent using the synchronization burst. There is no PDU type element in the SYNC PDU. The other broadcast PDU types shall be distinguished by a PDU type and broadcast type as shown in table 332.

**Table 332: Broadcast PDU contents**

Information element	Length	Type	Value	Remark
PDU type	2	M	10 <sub>2</sub>	Broadcast PDU
Broadcast type	2	M	00 <sub>2</sub>	SYSINFO PDU (BNCH content)
			01 <sub>2</sub>	ACCESS-DEFINE PDU
			10 <sub>2</sub>	Reserved
			11 <sub>2</sub>	Reserved
Broadcast elements				See following definitions for SYSINFO and ACCESS-DEFINE PDUs

The following clauses describe the contents of the three types of broadcast PDU.

## 21.4.4.1 SYSINFO

The SYSINFO PDU shall be transmitted using the BNCH on SCH/HD. It may also be sent using the stealing channel (STCH). Its contents shall be as shown in table 333.

Table 333: SYSINFO PDU contents

Information element	Length	Type	Value	Remark
PDU type	2	M	10 <sub>2</sub>	Broadcast PDU
Broadcast type	2	M	00 <sub>2</sub>	SYSINFO PDU
Main carrier	12	M		Frequency of the MCCH
Frequency band	4	M		Frequency band of the MCCH
Offset	2	M	00 <sub>2</sub>	0 kHz offset
			01 <sub>2</sub>	+6,25 kHz offset
			10 <sub>2</sub>	-6,25 kHz offset
			11 <sub>2</sub>	+12,5 kHz offset
Duplex spacing	3	M		Provision for different duplex spacing
Reverse operation	1	M	0	Normal
			1	Reverse
Number of common Secondary control Channels in use	2	M	00 <sub>2</sub>	None
			01 <sub>2</sub>	Timeslot 2 of main carrier
			10 <sub>2</sub>	Timeslots 2 and 3 of main carrier
			11 <sub>2</sub>	Timeslots 2, 3 and 4 of main carrier
MS_TXPWR_MAX_CELL	3	M	000 <sub>2</sub>	Reserved
			001 <sub>2</sub>	15 dBm
			...etc.	...etc.
			111 <sub>2</sub>	45 dBm (5dB steps)
RXLEV_ACCESS_MIN	4	M	0000 <sub>2</sub>	- 125 dBm
			...etc.	...etc.
			1111 <sub>2</sub>	- 50 dBm (5 dB steps)
ACCESS_PARAMETER	4	M	0000 <sub>2</sub>	- 53 dBm
			...etc.	...etc.
			1111 <sub>2</sub>	- 23 dBm (2 dB steps)
RADIO_DOWNLINK_TIMEOUT	4	M	0000 <sub>2</sub>	Disable radio downlink counter
			0001 <sub>2</sub>	144 timeslots
			0010 <sub>2</sub>	288 timeslots
			...etc.	...etc.
			1111 <sub>2</sub>	2 160 timeslots (multiples of 144)
Hyperframe / cipher key flag	1	M	0	Hyperframe number
			1	Common cipher key identifier
Hyperframe number	16	C		Cyclic count of hyperframes
CCK identifier or static cipher key version number	16	C		Common cipher key identifier or static cipher key version number, refer to EN 300 392-7 [11]
Optional field flag	2	M	00 <sub>2</sub>	Even multiframe definition for TS mode
			01 <sub>2</sub>	Odd multiframe definition for TS mode
			10 <sub>2</sub>	Default definition for access code A
			11 <sub>2</sub>	Extended services broadcast
TS_COMMON_FRAMES either for Even or Odd multiframe	20	C		Bit map of common frames for TS mode, see information element description in table 344
Default definition for access code A	20	C		See table 334
Extended services broadcast	20	C		See table 334a
TM-SDU (MLE data)	42	M		as defined in clause 18

The frequency of the main carrier shall be defined by the following information elements:

- main carrier;
- frequency band;
- offset;
- duplex spacing;
- reverse operation.

The frequency band field shall map to a specific frequency which shall map to a defined base frequency (in MHz) for the carrier numbering scheme. The main carrier field shall indicate the carrier frequency relative to the base frequency defined by the frequency band field. The main carrier field shall have step size of 25 kHz. The offset field shall then adjust the main carrier frequency by the given amount. (The offset field allows for the case where the carrier frequency is not  $N \times 25$  kHz above the base frequency.) The frequency so defined shall be the downlink frequency of the main carrier. This calculation shall be summarized by the following equation:

- downlink main carrier frequency = base frequency + (main carrier  $\times$  25 kHz) + offset kHz.

The uplink frequency of the main carrier shall be determined using the duplex spacing and reverse operation fields. The duplex spacing field shall map to a defined duplex spacing (in MHz) for the carrier numbering scheme. The duplex spacing shall be dependent on the frequency band element. The reverse operation field shall indicate whether to add or subtract the duplex spacing to arrive at the uplink frequency of the main carrier. If normal operation, the duplex spacing shall be subtracted. If reverse operation, the duplex spacing shall be added. This calculation is summarized by the following equations:

- normal operation:
  - uplink main carrier frequency = downlink main carrier frequency - duplex spacing.
- reverse operation:
  - uplink main carrier frequency = downlink main carrier frequency + duplex spacing.

The mapping of the frequency band field values to actual base frequencies and the duplex spacing field values to actual duplex frequency spacing are defined in TS 100 392-15 [49].

NOTE: These rules for calculation of uplink and downlink carrier frequency are also used for calculation of the carrier frequency in the channel allocation element.

RXLEV\_ACCESS\_MIN shall be used for cell selection and reselection. ACCESS\_PARAMETER shall be used for subsequent power adjustments.

The hyperframe/cipher key flag shall indicate whether the following information element is the hyperframe number information element or the CCK identifier or static cipher key version number information element. The usage of the CCK identifier or static cipher key version number information element is defined in EN 300 392-7 [11].

The optional field flag information element indicates which one of the optional information elements is present.

The TS\_COMMON\_FRAMES information element shall only be present if "Discontinuous TX" and "MCCH sharing" is indicated in the SYNC broadcast PDU. The optional field shall indicate whether TS\_COMMON\_FRAMES refers to odd or even multiframe definition.

If the optional field flag indicates a default access definition, then the 20-bit field corresponding to the default access code definition for access code A shall be present. Its contents shall be as defined in table 334.

**Table 334: Default definition for access code A information element contents**

Information element	Length	Type	Value	Remark
IMM (immediate)	4	M	0000 <sub>2</sub>	Always randomize
			0001 <sub>2</sub>	Randomize after IMM TDMA frames
			...etc.	...etc.
			1110 <sub>2</sub>	Randomize after IMM TDMA frames
			1111 <sub>2</sub>	Immediate access allowed
WT (waiting time)	4	M	0000 <sub>2</sub>	Reserved
			0001 <sub>2</sub>	Response within WT downlink opportunities
			...etc.	...etc.
			1111 <sub>2</sub>	Response within WT downlink opportunities
Nu (number of random access transmissions on uplink)	4	M	0000 <sub>2</sub>	No random access transmission allowed
			0001 <sub>2</sub>	1 random access transmission allowed
			...etc.	...etc.
			1111 <sub>2</sub>	15 random access transmissions allowed
Frame length factor	1	M	0	Multiply base frame length by 1
			1	Multiply base frame length by 4
Timeslot pointer	4	M	0000 <sub>2</sub>	Same as downlink slot assignment
			0001 <sub>2</sub>	Timeslot 4
			0010 <sub>2</sub>	Timeslot bit map
			...etc.	...etc.
			1110 <sub>2</sub>	Timeslot bit map
			1111 <sub>2</sub>	All four timeslots
Minimum priority	3	M	000 <sub>2</sub>	Priority 0 (lowest)
			...etc.	...etc.
			111 <sub>2</sub>	Priority 7 (highest)

If optional field flag indicates an extended service broadcast, the bits shall be used to inform the extended services provided according to table 334a.

**Table 334a: Extended services broadcast information element**

Information element	Length	M/C/O	Value	Remark
Security information	8			Refer to EN 300 392-7 [11].
SDS-TL addressing Method	2	M	00 <sub>2</sub>	Reserved
			01 <sub>2</sub>	Service centre addressing preferred (see note 1)
			10 <sub>2</sub>	Never use service centre addressing (see note 1)
			11 <sub>2</sub>	MS choice to use service centre addressing (see note 1)
GCK Supported	1	M		Refer to EN 300 392-7 [11] (see note 2)
Reserved	9	M		Reserved, value shall be set to "000000000 <sub>2</sub> "
NOTE1: Refer to clause 29 for further information.				
NOTE2: This shall be ignored by the MS when AI encryption is not available (indicated in BS Service Details).				

Each of the optional fields comprises 20 bits (including reserved bits) so that the SYSINFO PDU fully occupies all 124 bits of the MAC block in all cases.

#### 21.4.4.2 SYNC

The SYNC PDU shall be transmitted using the BSCH and so shall be distinguishable by the synchronization burst which has a special training sequence. Its contents shall be as shown in table 335.

The sharing mode field shall indicate whether the BS is using continuous transmission, carrier sharing, MCCH sharing or traffic carrier sharing. If MCCH sharing is indicated, the TS reserved frames field shall indicate which frames are reserved in this mode of operation. For the other values of sharing mode, the contents of the TS reserved frames field shall be ignored.

The frame 18 extension element shall indicate whether an MS is allowed to receive downlink information on all slots of the frame 18. If extension is allowed, only MSs which are capable of receiving consecutive slots are able to perform this function.

The U-plane DTX flag shall indicate whether discontinuous U-plane transmission is supported on traffic channels.

Table 335: SYNC PDU contents

Information element	Length	Type	Value	Remark
System code	4	M	0000 <sub>2</sub>	ETS 300 392-2 ed. 1 (no security functions)
			0001 <sub>2</sub>	ETS 300 392-2 ed. 1 and EN 300 392-7 [11] v2.1.1
			0010 <sub>2</sub>	EN 300 392-2 v2.3.2 and EN 300 392-7 [11] v2.1.1
			0XXX <sub>2</sub>	Other XXX <sub>2</sub> values V+D reserved
			100y <sub>2</sub>	Reserved
			101y <sub>2</sub>	Direct Mode Operation, see EN/ETS 300 396 (DMO)
			11zz <sub>2</sub>	Direct Mode Operation, see EN/ETS 300 396
Colour code	6	M	000000 <sub>2</sub>	Pre-defined scrambling, see note
			000001 <sub>2</sub>	Operator defined scrambling, for cell identifier and scrambling process as defined in clause 8
			...etc.	...etc.
			111111 <sub>2</sub>	Operator defined scrambling, for cell identifier and scrambling process as defined in clause 8
Timeslot number	2	M	00 <sub>2</sub>	Timeslot 1
			01 <sub>2</sub>	Timeslot 2
			10 <sub>2</sub>	Timeslot 3
			11 <sub>2</sub>	Timeslot 4
Frame number	5	M	00000 <sub>2</sub>	Reserved
			00001 <sub>2</sub>	Frame 1
			...etc.	...etc.
			10010 <sub>2</sub>	Frame 18
			Others	Reserved
Multiframe number	6	M	000000 <sub>2</sub>	Reserved
			000001 <sub>2</sub>	Multiframe 1
			...etc.	...etc.
			111100 <sub>2</sub>	Multiframe 60
			Others	Reserved
Sharing mode	2	M	00 <sub>2</sub>	Continuous transmission
			01 <sub>2</sub>	Carrier Sharing
			10 <sub>2</sub>	MCCH sharing
			11 <sub>2</sub>	Traffic carrier sharing
TS reserved frames	3	M	000 <sub>2</sub>	1 frame reserved/2 multiframe
			001 <sub>2</sub>	2 frames reserved/2 multiframe
			010 <sub>2</sub>	3 frames reserved/2 multiframe
			011 <sub>2</sub>	4 frames reserved/2 multiframe
			100 <sub>2</sub>	6 frames reserved/2 multiframe
			101 <sub>2</sub>	9 frames reserved/2 multiframe
			110 <sub>2</sub>	12 frames reserved/2 multiframe
			111 <sub>2</sub>	18 frames reserved/2 multiframe
U-plane DTX	1	M	0	Discontinuous U-plane transmission is not allowed
			1	Discontinuous U-plane transmission is allowed
Frame 18 extension	1	M	0	No frame 18 extension
			1	Frame 18 extension allowed
Reserved	1	M	0	Default value
			1	Not used in the present document
TM-SDU (MLE data)	29	M		as defined in clause 18

NOTE: The element Colour code with the value "Predefined scrambling" means that all 30 bits of the scrambling vector are zeros.

### 21.4.4.3 ACCESS-DEFINE

The ACCESS-DEFINE PDU may be sent by the BS using a half slot or full slot on the downlink (SCH/HD or SCH/F) or on downlink STCH. It defines the random access parameters for the specified access code and its contents shall be as given in table 336.

**Table 336: Access define PDU contents**

Information element	Length	Type	Value	Remark
PDU type	2	M	10 <sub>2</sub>	Broadcast PDU
Broadcast type	2	M	01 <sub>2</sub>	ACCESS-DEFINE PDU
Common or assigned control channel flag	1	M	0	ACCESS-DEFINE applies to common ch'l
			1	ACCESS-DEFINE applies to assigned ch'l
Access code	2	M	00 <sub>2</sub>	Access code A
			01 <sub>2</sub>	Access code B
			10 <sub>2</sub>	Access code C
			11 <sub>2</sub>	Access code D
IMM (immediate)	4	M	0000 <sub>2</sub>	Always randomize
			0001 <sub>2</sub>	Randomize after IMM TDMA frames
			...etc.	...etc.
			1110 <sub>2</sub>	Randomize after IMM TDMA frames
WT (waiting time)	4	M	1111 <sub>2</sub>	Immediate access allowed
			0000 <sub>2</sub>	Reserved
			0001 <sub>2</sub>	Response within WT downlink opportunities
			...etc.	...etc.
Nu (number of random access transmissions on uplink)	4	M	1111 <sub>2</sub>	Response within WT downlink opportunities
			0000 <sub>2</sub>	No random access transmission allowed
			0001 <sub>2</sub>	1 random access transmission allowed
			...etc.	...etc.
Frame length factor	1	M	1111 <sub>2</sub>	15 random access transmissions allowed
			0	Multiply base frame length by 1
Timeslot pointer	4	M	1	Multiply base frame length by 4
			0000 <sub>2</sub>	Same as downlink slot assignment
			0001 <sub>2</sub>	Timeslot 4
			0010 <sub>2</sub>	Timeslot bit map
			...etc.	...etc.
			1110 <sub>2</sub>	Timeslot bit map
Minimum priority	3	M	1111 <sub>2</sub>	All four timeslots
			000 <sub>2</sub>	Priority 0 (lowest)
			...etc.	...etc.
Optional field flag	2	M	111 <sub>2</sub>	Priority 7 (highest)
			00 <sub>2</sub>	None
			01 <sub>2</sub>	Subscriber class bit map
			10 <sub>2</sub>	GSSI
Subscriber class bitmap	16	C		Reserved, see note
GSSI	24	C		as defined in clause 18
Filler bits	3	M	100 <sub>2</sub>	Group short subscriber identity
				Reserved bits to make the PDU octet bounded

NOTE: Values 00<sub>2</sub> and 11<sub>2</sub> indicate that there is no added optional field.

The definition of the various random access parameters is as follows:

- common or assigned flag:
  - this indicates whether the ACCESS-DEFINE PDU applies to MS using the channel for common control or MS using it for assigned control;



- access code:
  - this is used in the ACCESS-ASSIGN message to control access for a subdivision of the MS population;
- IMM:
  - this is the Aloha parameter defining when the MS may use the first valid access opportunity for its first random access transmission. This time is counted in terms of TDMA frames;
- WT:
  - this is the Aloha parameter defining the waiting time before the MS decides to initiate an access re-try. This time is counted in terms of BS downlink signalling opportunities for this control channel;
- Nu:
  - this is the Aloha parameter giving the number of random access transmissions an MS may send before abandoning the random access attempt;
- frame length factor:
  - this is a multiplying factor applied to the base frame length contained in the ACCESS-ASSIGN message;
- timeslot pointer:
  - this is a pointer to where the ACCESS-ASSIGN message shall be monitored.

### 21.4.5 TMD-SAP: MAC PDU structure for U-plane signalling

The MAC-U-SIGNAL PDU shall be used on the uplink and downlink for sending U-plane signalling information. This PDU shall only be sent using the STCH in conjunction with an established circuit mode. Its contents shall be as shown in table 337.

**Table 337: MAC-U-SIGNAL PDU contents**

Information element	Length	Type	Value	Remark
PDU type	2	M	11 <sub>2</sub>	MAC-U-SIGNAL
Second half slot stolen flag	1	M	0	Second half slot not stolen
			1	Second half slot stolen
TM-SDU	121	M		

The first two bits of the MAC header shall distinguish this PDU as a MAC-U-SIGNAL PDU. The second half slot stolen flag shall indicate whether the second half of the full slot is also stolen. If the second half is stolen it may contain U-plane or C-plane signalling as indicated by the MAC header. The SDU contains the user information which is received from the U-plane for transmission in this PDU or passed to the U-plane on receipt of this PDU. It shall be the responsibility of the user application at the higher layer to specify the meaning of the contents of the TM-SDU. The TM-SDU length shall always be 121 bits. If the user application requires fewer bits, it is the responsibility of that application to insert filler bits to ensure a 121 bit TM-SDU length.

If MAC-U-SIGNAL is sent in the second half of a full slot, the second half slot stolen flag shall still be present but its content shall be ignored.

### 21.4.6 TMD-SAP: MAC PDU structure for U-plane traffic

The MAC-TRAFFIC PDU shall be used for sending U-plane traffic data on the uplink and downlink using TCH/S, TCH/7,2, TCH/4,8 or TCH/2,4. This PDU has no header and all capacity shall be devoted to traffic information passed to and from the U-plane. When the MAC is in traffic mode, this PDU type shall be assumed unless the slot flag indicates the presence of the STCH.

When stealing does not occur, the MAC-TRAFFIC PDU shall occupy the full slot. If stealing occurs, and only the first half of the slot is stolen, the MAC-TRAFFIC PDU shall occupy the second half of the slot.

## 21.4.7 MAC PDU structure for access assignment broadcast

The ACCESS-ASSIGN PDU is generated by the MAC and so shall not contain any TM-SDU from the layer above. The ACCESS-ASSIGN PDU shall use the AACH which is mapped onto the broadcast block and shall be sent by the BS on every downlink slot (refer to clause 9). This PDU shall be used to convey information about the downlink slot in which it appears and also the access rights for the corresponding (same-numbered) uplink slot. Its contents shall be dependent on whether it is being sent in frames 1 to 17 or in frame 18. The contents of this PDU shall be as shown in tables 338 and 339.

**Table 338: ACCESS-ASSIGN PDU contents for frames 1 to 17**

Information element	Length	Type	Value	Remark
Header	2	M	00 <sub>2</sub>	Downlink usage - common control Uplink access rights - common only
			01 <sub>2</sub>	Downlink usage - defined by field 1 Uplink access rights - common and assigned
			10 <sub>2</sub>	Downlink usage - defined by field 1 Uplink access rights - assigned only
			11 <sub>2</sub>	Downlink usage- defined by field 1 Uplink access rights - defined by field 2
Field 1	6	M	see note	Header 00 <sub>2</sub> : Access field 1 Header 01 <sub>2</sub> : Downlink usage marker Header 10 <sub>2</sub> : Downlink usage marker Header 11 <sub>2</sub> : Downlink usage marker
Field 2	6	M	see note	Header 00 <sub>2</sub> : Access field 2 Header 01 <sub>2</sub> : Access field Header 10 <sub>2</sub> : Access field Header 11 <sub>2</sub> : Uplink usage marker
NOTE:	Content and values of the fields 1 and 2 depends on the Header values as defined in the Remarks column.			

Possible values for downlink usage marker in the field 1:

- Reserved (see note 1)      UMr    000011<sub>2</sub>
- Common control              UMc    000010<sub>2</sub>
- Assigned control            UMa    000001<sub>2</sub>
- Unallocated                 UMx    000000<sub>2</sub>
- Traffic                        UMt    others (see note 2)

Possible values for uplink usage marker in the field 2:

- Unallocated                 UMx    000000<sub>2</sub>
- Traffic                        UMt    others (see note 2)

NOTE 1: UMr value is reserved for future standardization and is not used in the present document.

NOTE 2: The values of the UMr, UMc, UMa and UMx are excluded.

UMc, UMa and UMx are pre-set usage markers which shall not be assigned as traffic usage markers. UMt is the traffic usage marker, assigned in the MAC-RESOURCE PDU which allocated the channel.

Access field 1 shall indicate the access restrictions for the first subslot of the corresponding uplink slot. Access field 2 shall indicate the access restrictions for the second subslot of the corresponding uplink slot. Access field (with no following number) shall indicate the access restrictions for both subslots of the corresponding uplink slot. The definition of the access field contents is given in the access field element definition.

Table 339: ACCESS-ASSIGN PDU contents for frame 18

Information element	Length	Type	Value	Remark
Header	2	M	00 <sub>2</sub>	Uplink access rights: common only
			01 <sub>2</sub>	Uplink access rights: common and assigned
			10 <sub>2</sub>	Uplink access rights: assigned only
			11 <sub>2</sub>	Uplink access rights: common and assigned
Field 1	6	M	see note	Header 00 <sub>2</sub> : Access field 1 Header 01 <sub>2</sub> : Access field 1 Header 10 <sub>2</sub> : Access field 1 Header 11 <sub>2</sub> : Traffic usage marker (UMt)
Field 2	6	M	see note	Header 00 <sub>2</sub> : Access field 2 Header 01 <sub>2</sub> : Access field 2 Header 10 <sub>2</sub> : Access field 2 Header 11 <sub>2</sub> : Access field
NOTE:	Content and values of the fields 1 and 2 depends on the Header values as defined in the Remarks column.			

## 21.5 MAC elements

Clauses 21.5.1 to 21.5.6 describe the information elements which are referred to in the MAC PDU descriptions. The contents of those information elements shall as defined in tables 340 to 345.

### 21.5.1 Access field

Table 340: Access field information element contents

Information element	Length	Type	Value	Remark
Access code	2	M	00 <sub>2</sub>	Access code A
			01 <sub>2</sub>	Access code B
			10 <sub>2</sub>	Access code C
			11 <sub>2</sub>	Access code D
Base frame-length	4	M	0000 <sub>2</sub>	Reserved subslot, see note 1
			0001 <sub>2</sub>	CLCH subslot, see notes 1 and 2
			0010 <sub>2</sub>	Ongoing frame
			0011 <sub>2</sub>	1 subslot
			0100 <sub>2</sub>	2 subslots
			0101 <sub>2</sub>	3 subslots
			0110 <sub>2</sub>	4 subslots
			0111 <sub>2</sub>	5 subslots
			1000 <sub>2</sub>	6 subslots
			1001 <sub>2</sub>	8 subslots
			1010 <sub>2</sub>	10 subslots
			1011 <sub>2</sub>	12 subslots
			1100 <sub>2</sub>	16 subslots
			1101 <sub>2</sub>	20 subslots
1110 <sub>2</sub>	24 subslots			
1111 <sub>2</sub>	32 subslots			
NOTE 1:	For these values access code has no meaning.			
NOTE 2:	CLCH is permitted only in subslot 1 as specified in clause 9.5.1.			

## 21.5.2 Channel allocation

**Table 341: Channel allocation information element contents**

Information element	Length	Type	Value	Remark
Allocation type	2	M	00 <sub>2</sub>	Replace current channel with specified channel
			01 <sub>2</sub>	Additional channel allocation
			10 <sub>2</sub>	Quit current channel and go to specified channel
			11 <sub>2</sub>	Replace current channel with specified channel plus carrier specific signalling channel in slot 1
Timeslot assigned	4	M	0000 <sub>2</sub>	Go to appropriate common control channel (MCCH or common SCCH)
			0001 <sub>2</sub>	Timeslot number 4
			0010 <sub>2</sub>	Timeslot number bit map
			...etc.	...etc.
			1110 <sub>2</sub>	Timeslot bit map
Up/downlink assigned	2	M	00 <sub>2</sub>	Reserved
			01 <sub>2</sub>	Downlink only
			10 <sub>2</sub>	Uplink only
			11 <sub>2</sub>	Both uplink and downlink
CLCH permission	1	M	0	No immediate CLCH permission
			1	Immediate CLCH permission
Cell change flag	1	M	0	No cell change
			1	Cell change
Carrier number	12	M		Carrier frequency number
Extended carrier numbering flag	1	M	0	No extended carrier numbering
			1	Extended carrier numbering
Frequency band	4	C		Provision for different frequency bands
Offset	2	C		Provision for different offsets
Duplex spacing	3	C		Provision for different duplex spacing
Reverse operation	1	C	0	Normal
			1	Reverse
Monitoring pattern (see clause 9)	2	M	00 <sub>2</sub>	No monitoring pattern
			01 <sub>2</sub>	One monitoring pattern
			10 <sub>2</sub>	Two monitoring patterns
			11 <sub>2</sub>	Three monitoring patterns
Frame 18 monitoring pattern	2	C	00 <sub>2</sub>	No monitoring pattern
			01 <sub>2</sub>	One monitoring pattern
			10 <sub>2</sub>	Two monitoring patterns
			11 <sub>2</sub>	Three monitoring patterns

The CLCH permission field shall indicate to the MS whether the first sub-slot on the assigned channel shall be available for linearization purposes. The MS need not examine the AACH field in order to use CLCH if permission is given in the channel allocation field.

The carrier frequency shall be defined by the following elements:

- carrier number;
- extended carrier numbering flag;
- frequency band;
- offset;
- duplex spacing;
- reverse operation.

The extended numbering flag indicates whether the carrier frequency specification includes the frequency band, offset, duplex spacing and reverse operation fields. If this field indicates no extended numbering, then the MS shall assume the same frequency band, offset, duplex spacing and reverse operation values as contained in the SYSINFO PDU. The actual carrier frequency shall then be calculated using the same equations as defined for the main carrier frequency calculation in the SYSINFO PDU description (but with the allocated "carrier number" replacing "main carrier"), refer to TS 100 392-15 [49].

The monitoring pattern field applies to a transmitting MS on an assigned channel and it indicates which downlink slots shall be monitored while transmitting traffic. If one monitoring pattern is assigned, monitoring pattern number one as defined in clause 9 shall be used. If two monitoring patterns are assigned, monitoring pattern numbers one and two as defined in clause 9 shall be used. If three monitoring patterns are assigned, monitoring pattern numbers one, two and three as defined in clause 9 shall be used.

If no monitoring pattern is assigned, then the frame 18 monitoring pattern field shall be included to indicate which monitoring patterns shall be followed for frame 18. One, two or three monitoring patterns can be assigned for frame 18 in the same way as described before. So, for example, if one monitoring pattern is assigned, the MS shall monitor frame 18 if Multiframe Number mod 3 = 0; if two monitoring patterns are assigned, the MS shall monitor frame 18 if Multiframe Number mod 3 = 0 or 2.

### 21.5.3 Power control

**Table 342: Power control information element contents**

Information element	Length	Type	Value	Remark
Power control	4	M	0000 <sub>2</sub>	No change in power
			0001 <sub>2</sub>	Increase power by 1 step
			0010 <sub>2</sub>	Increase power by 2 steps
			0011 <sub>2</sub>	Increase power by 3 steps
			0100 <sub>2</sub>	Increase power by 4 steps
			0101 <sub>2</sub>	Increase power by 5 steps
			0110 <sub>2</sub>	Increase power by 6 steps
			0111 <sub>2</sub>	Maximum path delay exceeded
			1000 <sub>2</sub>	Revert to open loop power control
			1001 <sub>2</sub>	Decrease power by 1 step
			1010 <sub>2</sub>	Decrease power by 2 steps
			1011 <sub>2</sub>	Decrease power by 3 steps
			1100 <sub>2</sub>	Decrease power by 4 steps
			1101 <sub>2</sub>	Decrease power by 5 steps
1110 <sub>2</sub>	Decrease power by 6 steps			
1111 <sub>2</sub>	Radio uplink failure			

The power control step size is nominally 5 dB as defined in clause 6 except for power classes nL, where n is 1 to 4, refer table 3. For those power classes the step between the nominal power and the first lower power level is 2,5 db so that the control power levels of the table 4 are applicable except for the highest power. The power shall not be decreased below the minimum power control level of 15 dBm or above the nominal power of that MS class.

## 21.5.4 Reservation requirement

**Table 343: Reservation requirement information element contents**

Information element	Length	Type	Value	Remark
Reservation requirement	4	M	0000 <sub>2</sub>	1 subslot required
			0001 <sub>2</sub>	1 slot required
			0010 <sub>2</sub>	2 slots required
			0011 <sub>2</sub>	3 slots required
			0100 <sub>2</sub>	4 slots required
			0101 <sub>2</sub>	5 slots required
			0110 <sub>2</sub>	6 slots required
			0111 <sub>2</sub>	8 slots required
			1000 <sub>2</sub>	10 slots required
			1001 <sub>2</sub>	13 slots required
			1010 <sub>2</sub>	17 slots required
			1011 <sub>2</sub>	24 slots required
			1100 <sub>2</sub>	34 slots required
			1101 <sub>2</sub>	51 slots required
			1110 <sub>2</sub>	68 slots required
1111 <sub>2</sub>	More than 68 slots required			

## 21.5.5 TS\_COMMON\_FRAMES

**Table 344: TS\_COMMON\_FRAMES information element contents**

Information element	Length	Type	Value	Remark
Frame 1	1	M	0	Not a common frame
			1	Common frame
Frame 2	1	M	0	Not a common frame
			1	Common frame
...etc.	...etc.	...etc.	0	...etc.
			1	...etc.
Frame 18	1	M	0	Not a common frame
			1	Common frame
Reserved	1	M	0	Default value
			1	Not used in the present document
Reserved	1	M	0	Default value
			1	Not used in the present document

## 21.5.6 Slot granting

**Table 345: Slot granting information element contents**

Information element	Length	Type	Value	Remark
Capacity Allocation	4	M	0000 <sub>2</sub>	First subslot allocated
			0001 <sub>2</sub>	1 slot allocated
			0010 <sub>2</sub>	2 slots allocated
			0011 <sub>2</sub>	3 slots allocated
			0100 <sub>2</sub>	4 slots allocated
			0101 <sub>2</sub>	5 slots allocated
			0110 <sub>2</sub>	6 slots allocated
			0111 <sub>2</sub>	8 slots allocated
			1000 <sub>2</sub>	10 slots allocated
			1001 <sub>2</sub>	13 slots allocated
			1010 <sub>2</sub>	17 slots allocated
			1011 <sub>2</sub>	24 slots allocated
			1100 <sub>2</sub>	34 slots allocated
			1101 <sub>2</sub>	51 slots allocated
1110 <sub>2</sub>	68 slots allocated			
1111 <sub>2</sub>	Second subslot allocated			
Granting delay	4	M	0000 <sub>2</sub>	Capacity allocation at next opportunity
			0001 <sub>2</sub>	Number of opportunities delay to capacity allocation
			...etc.	...etc.
			1101 <sub>2</sub>	Number of opportunities delay to capacity allocation
			1110 <sub>2</sub>	Allocation starts at first opportunity in frame 18
			1111 <sub>2</sub>	Wait for another slot granting message

## 22 LLC protocol

This clause is intended to be read together with the MAC protocol, clause 23. This clause describes the LLC sub-layer framing functions for the V+D air interface. These sub-layer functions are closely integrated with the MAC sub-layer and together the MAC and LLC form the air interface layer 2, also called DLL. An overview of the DLL architecture can be found in clause 19.

### 22.1 Overview of LLC

See EN 300 392-1 [9], clause 6 for general architecture and functional description. See clause 19 for DLL architecture. See clause 20 for service description and SAPs. See clause 21 for PDU description.

The LLC procedures defined in the present document are applicable to the MS unless indicated to be valid for the BS. The LLC procedures used in the BS shall be compatible with the procedures described in the present document.

NOTE: In this clause the word "shall" is used with service primitives for traceability reasons in the protocol model, but the primitives are not testable.

#### 22.1.1 LLC protocol

LLC protocol for TETRA contains two entities, basic link and advanced link, both accessible via the same SAP TLA-SAP. Both the data links offer two different services, i.e. unacknowledged and acknowledged information transfer mechanisms. The basic link is available whenever the MS is synchronized to a BS. The advanced link provides a better quality of service than the basic link and uses a connection on demand. The basic link offers an option for extended FCS to minimize the number of undetected erroneous messages. The same frame check sequence is always used on the advanced link.

The MS LLC can support up to four advanced links per service, numbered from one to four. The various link services will be discriminated locally by a different end-point identifier. In the LLC itself, the distinct PDU types shall differentiate both between a basic and an advanced link and unacknowledged and acknowledged service (see clause 21). There shall be a unique correspondence between the end-point identifier and the timeslot or timeslots used in the MAC. End-point identifiers in the peer entity may be independent of these local identifiers. For a certain link number, there can exist one acknowledged service or one unacknowledged service or both. Unacknowledged and acknowledged services are set-up and disconnected independently of each other. If they coexist on the same link number, they shall use the same physical allocation (same time-slots). In this case there is only one basic link associated with both the advanced link services.

There is one basic link per each advanced link and each circuit mode service, when an ACCH is available. The number of timeslots each basic link may use, is the same as the number of timeslots of the corresponding advanced link or circuit mode service.

The transfer mode of an LLC link is independent of the modes of the other LLC links forming a network layer connection. As an example, a point-to-multipoint call from an MS to multiple MSs may use an advanced LLC link from the sending MS to the BS and the unacknowledged basic LLC link from the BS to the receiving MSs.

This LLC protocol for TETRA operates using PDUs. The PDUs are described in clause 21. The basic link LLC PDU sizes are independent of the MAC layer block sizes, because MAC can fragment an LLC PDU if needed. The advanced link LLC protocol is constrained by the segment sizes matching the available room in MAC blocks. The data link operation may use the knowledge of the multiframe structure for transmission optimization.

### 22.1.2 Communication routes of the LLC model

Figure 101 shows relations of the MS LLC layer protocols in the TETRA protocol stack. The service user selects service and signal route by selecting endpoint identifier at the TLA-SAP. There is also an LLC flow control provided between LLC peer entities on the advanced link. The flow control is accessible to the LLC service user via a MLE-LLC control route.



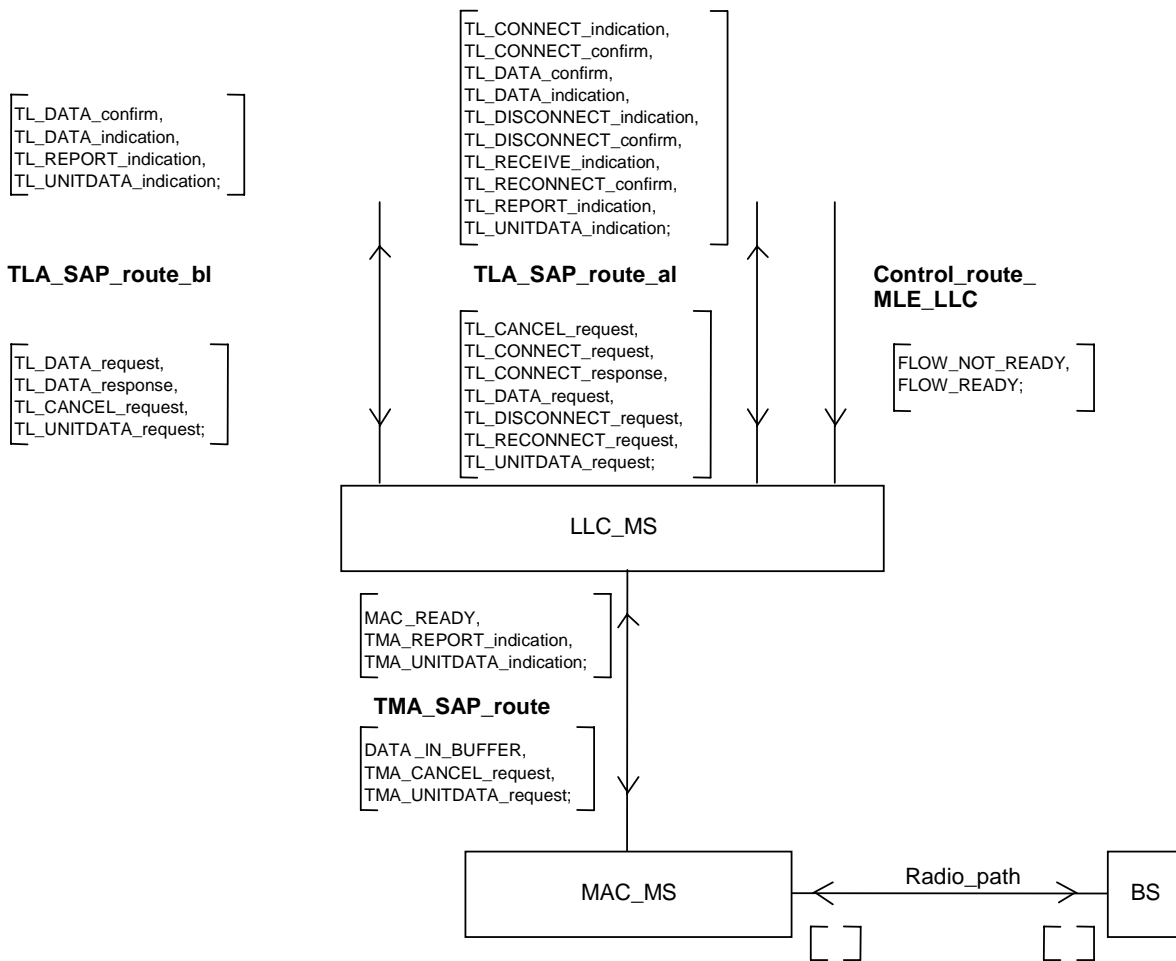


Figure 101: LLC relations

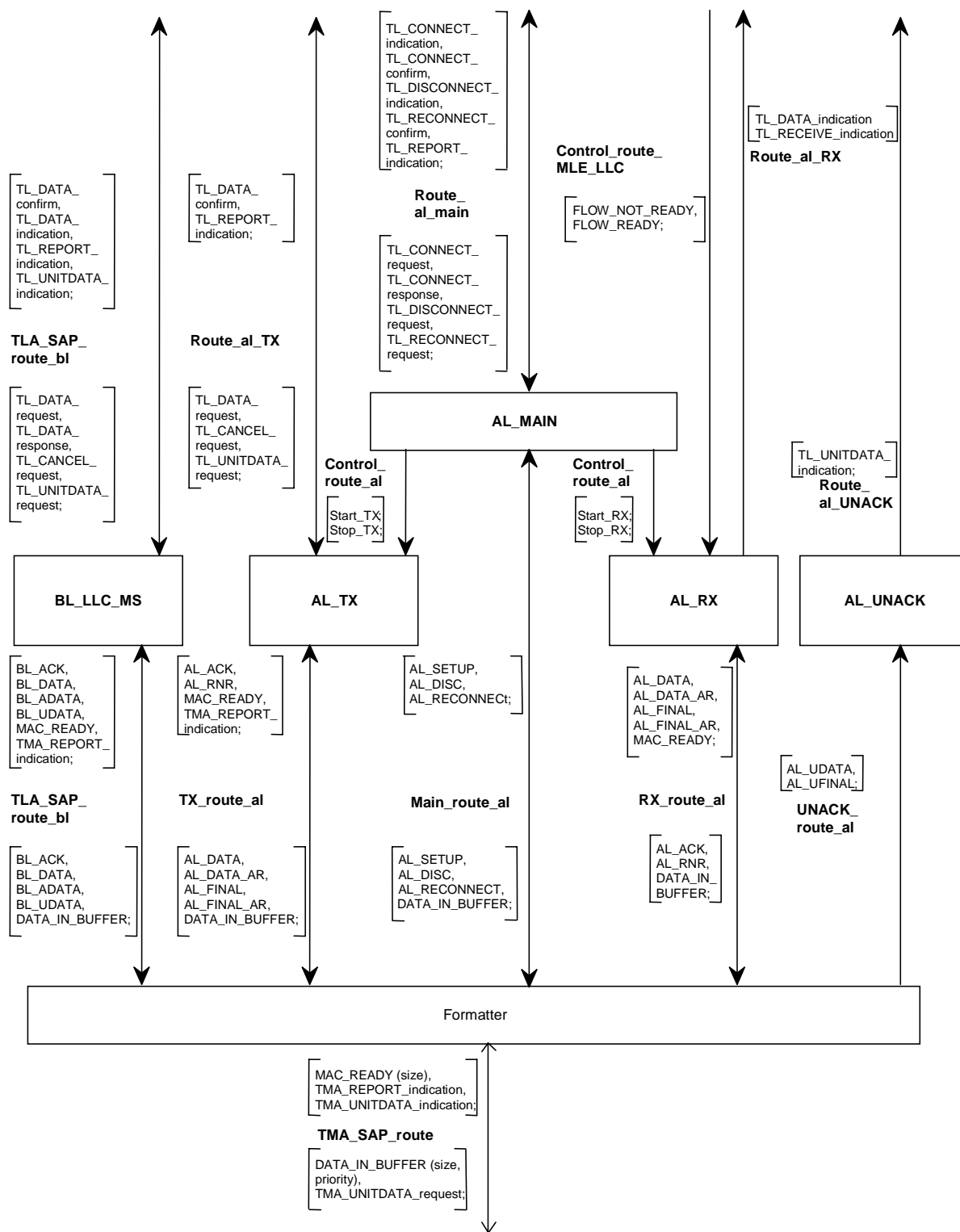


Figure 102: LLC protocol structure

Figure 102 shows the internal structure of the LLC presenting the basic and the advanced links and layer composition of various processes.

The basic link protocol uses the following routes:

- the TLA-SAP route bl corresponds to the TLA-SAP;
- the TX-RX route bl corresponds to TMA-SAP showing LLC PDUs.

The advanced link protocol uses following routes:

- the Route al main corresponds to the TLA-SAP for the connection set-up, reconnection and disconnection;
- the Route al TX corresponds to the TLA-SAP for acknowledged data transmission;
- the Route al RX corresponds to the TLA-SAP for acknowledged data reception;
- the Control Route MLE-LLC corresponds to the TLA-SAP for flow control purposes;
- the Main route al corresponds to TMA-SAP and carries LLC PDUs for connection set-up, reconnection and disconnection;
- the TX route al corresponds to TMA-SAP and carries LLC PDUs and control signals, which are used in acknowledged data transmission;
- the RX route al corresponds to TMA-SAP and carries LLC PDUs and control signals, which are used in acknowledged data reception;
- the Route al UNACK corresponds to TLA-SAP for unacknowledged service;
- the UNACK route al corresponds to TMA-SAP and carries LLC unacknowledged service PDUs;
- the Control route al carries local control of the advanced links.

Information exchange between LLC and MAC:

- the TMA-SAP route corresponds to the TMA-SAP, and carries primitives and local information exchange.

NOTE: The creation of the routes is considered to be an implementation issue and they are not shown in figure 102.

## 22.2 Scenarios on LLC procedures

This clause describes scenarios for normal TL-SDU transfer cases. For clarity many details such as TL-REPORT indications are not included into message sequence diagrams.

### 22.2.1 Basic link mode

The basic link is available for information transfer whenever the MS is synchronized to a BS. There are two data transfer modes, acknowledged and unacknowledged PDU transfer. The acknowledged data transfer can be used for point-to-point communication and the unacknowledged data transfer can be used both for point-to-multipoint and point-to-point communication.

#### 22.2.1.1 Acknowledged PDU transfer (BL-DATA + BL-ACK)

Figure 103 and figure 104 show the transfer of information when the basic link is used. This protocol supports a message pair exchange based on primitives TL-DATA request and TL-DATA indication in one direction and on primitives TL-DATA response and TL-DATA confirm in the other direction as shown in figure 103. The TL-SDU from the left hand side entity is transmitted in the BL-DATA PDU. The TL-SDU in the TL-DATA response primitive from the right hand side LLC to the left hand side LLC is transferred in the BL-ACK PDU. That TL-SDU is not acknowledged directly with an explicit transfer of an acknowledgement PDU (though the left hand side entity may retransmit its BL-DATA PDU if it does not receive the BL-ACK PDU). Each BL-DATA PDU carries a TL-SDU number N(S), which indicates the number of the present BL-DATA PDU in that direction of information flow. The peer entity acknowledges the successful reception of this BL-DATA PDU by sending the same TL-SDU number N(R) in the acknowledgement BL-ACK PDU, see figure 104 for the PDU exchange.

NOTE: This protocol uses in the acknowledgement message the same message number as in the received data message in contrary to most HDLC protocols, which typically rely on a continuous message exchange and use in the acknowledgement the next expected message number.

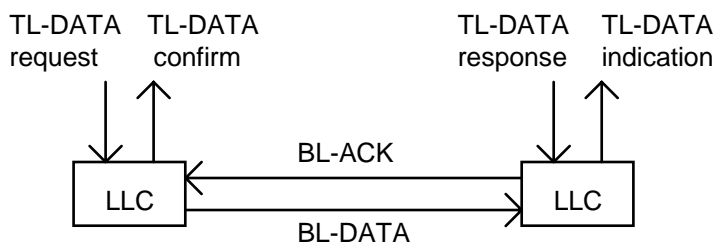
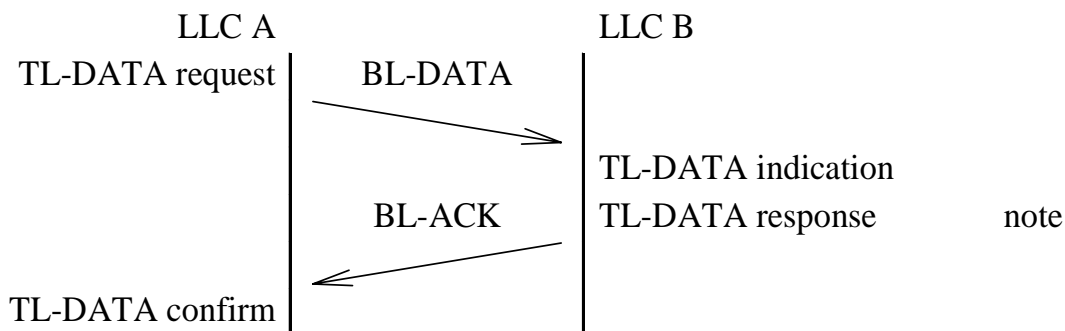


Figure 103: Basic link PDU exchange with acknowledgement carrying a layer 3 message



NOTE: BL-ACK includes the response data from the service user.

Figure 104: Basic link data transfer and acknowledgement with a layer 3 message

In the previous scenario there was a layer 3 TL-DATA response available, when the BL-ACK PDU was sent. If there is no layer 3 information available, then a short acknowledgement PDU is sent as shown in figures 105 and 106. The LLC assumes that the LLC service user will normally provide a TL-DATA response to the TL-DATA indication before the LLC and MAC has the next opportunity to send the BL-ACK PDU as shown above. If the TL-DATA response is offered to the LLC after the sending of the BL-ACK PDU, then the LLC sends it as if it were a TL-DATA request using a BL-DATA PDU, which is presented to the receiving service user as a TL-DATA indication primitive and will be confirmed, see the second set of primitives in figures 105 and 106.

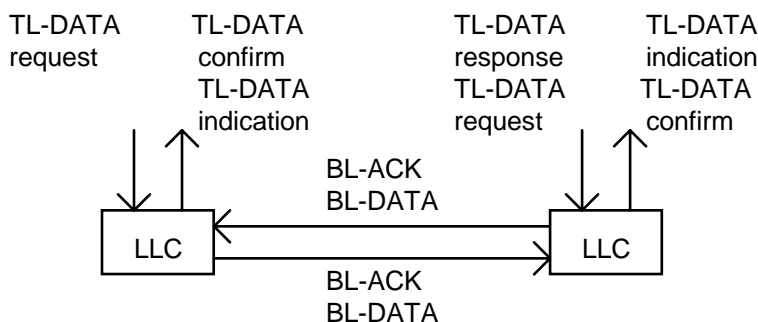
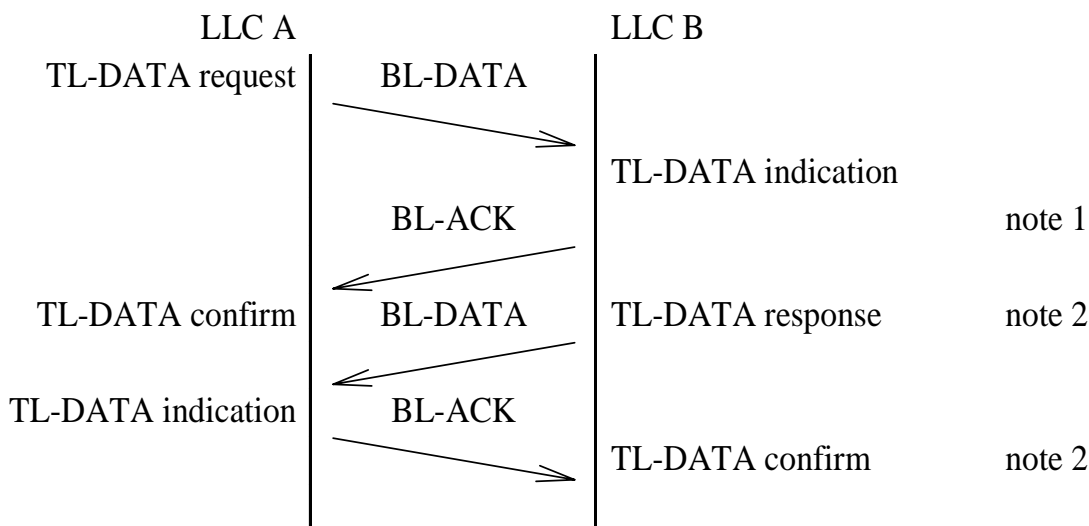


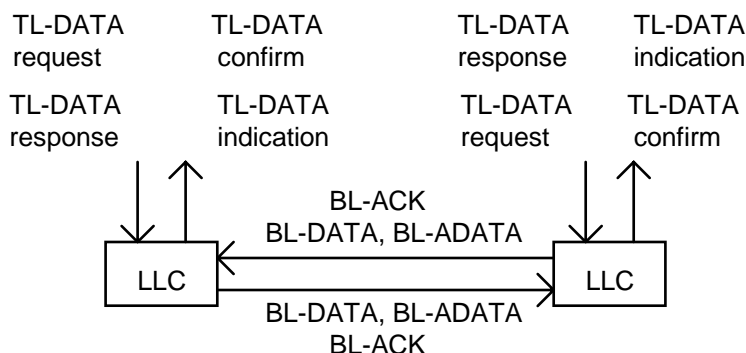
Figure 105: Basic link PDU exchange with LLC acknowledgement with a delayed response



NOTE 1: When there is no TL-DATA response available, then LLC sends an acknowledgement without data.  
 NOTE 2: The LLC transfers a delayed TL-SDU in the TL-DATA response primitive using normal acknowledged service as if it were a TL-DATA request and a successful transfer will be confirmed with a TL-DATA confirm primitive to the service user.

**Figure 106: Basic link data transfer and acknowledgement with a delayed layer 3 response**

The basic link also allows concurrent data transfer in both directions independent of each other as shown generally in figure 107 and as an example in figure 108. A TL-DATA request is sent in a BL-DATA PDU from the LLC A. The LLC B may combine the acknowledgement and the user data from a TL-DATA request into a BL-ADATA PDU. At the LLC A receiver the acknowledgement will be delivered to the service user in a TL-DATA confirm and the user data is delivered in an independent TL-DATA indication. The example continues with the second TL-DATA request and with the corresponding combined BL-ADATA PDU. To the resulting TL-DATA indication the LLC B responds with a TL-DATA response primitive and the user data is sent in a BL-ACK PDU. This is delivered to the service user in a TL-DATA confirm primitive and there is no explicit acknowledgement sent to that data. The next user data PDU from the LLC A will be a BL-DATA PDU and it is in this example acknowledged by a BL-ACK PDU without data. If the user does not want to send a response but an independent data, see figure 108, see note 1, then a TL-DATA request primitive is used and the LLC will acknowledge the received data either with a BL-ACK or with a BL-ADATA PDU. In figure 107 there are two sets of service primitives, the upper and lower are used in the information flow from left to right and from right to left respectively.



**Figure 107: Concurrent independent message exchange in both directions**



NOTE 1: Service user offers a data request instead of a response.

NOTE 2: There may be also a data response, which is carried in BL-ACK PDU and will not be acknowledged directly.

**Figure 108: Concurrent independent message exchange in both directions**

The LLC sends reports, or reports on the progress of data sending, to the service user based on information from MAC layer. Those reports will be explained in the protocol description and are not presented here.

In this protocol, a single TL-SDU, in a BL-DATA or BL-ADATA PDU, is sent and acknowledged at a time and the window size is equal to 1. There is no peer-to-peer flow control mechanism for the basic link.

### 22.2.1.2 Unacknowledged data transfer (BL-UDATA PDU)

Unacknowledged mode of operation is mainly used to address a group of MSs (point-to-multipoint) as shown in figures 109 and 110, where the BL-UDATA PDU is used to transfer information. No responses nor acknowledgements are expected to a BL-UDATA PDU. The sending LLC entity may repeat a UDATA PDU several times to increase the probability of a correct reception. The receiving protocol does not suppress received duplicates. The LLC may send a report or reports on the progress of data sending to the service user.

The BL-UDATA PDU may be used also for sending data from an MS to the base station.

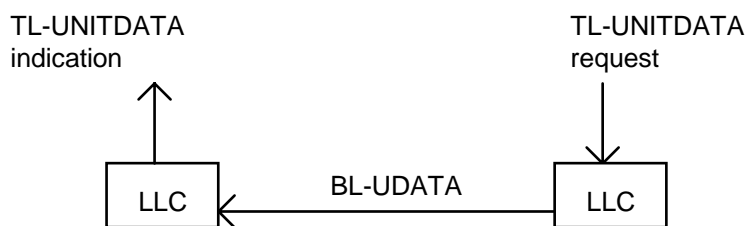


Figure 109: PDU exchange in unacknowledged mode

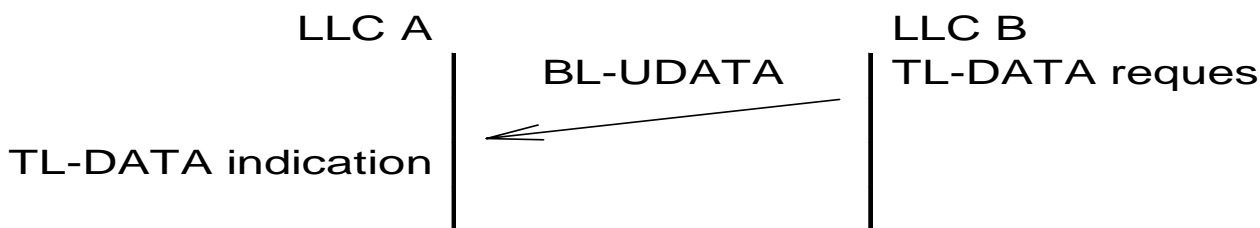


Figure 110: Basic link data transfer in unacknowledged mode

22.2.1.3 Unacknowledged data transfer with presence indication (BL-DATA + BL-ACK PDU)

This clause describes how a BS may implement presence checking in group call establishment.

This operation mode of the BS allows sending of unacknowledged data and requesting a low level presence indication from one or more recipient MS. The presence indication message carries only indication that at least one MS has received the message correctly and shall not contain a TL-SDU, see figure 111 and figure 112. In response to the TL-DATA request with a presence indication parameter the base station sends a normal BL-DATA PDU and waits for an answer from one or more MSs. The MS LLC sends a normal acknowledgement, which is detected in the BS without actually decoding it especially if many MSs have answered at the same time. The BS LLC does not re-send the BL-DATA PDU to get back a de-codeable BL-ACK PDU, but it may send BL-DATA PDU more than once for more reliable data transfer.

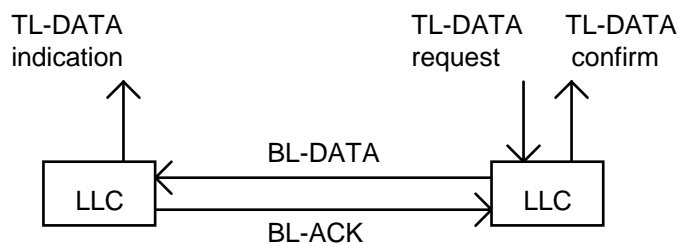


Figure 111: Basic link data transfer with presence indication

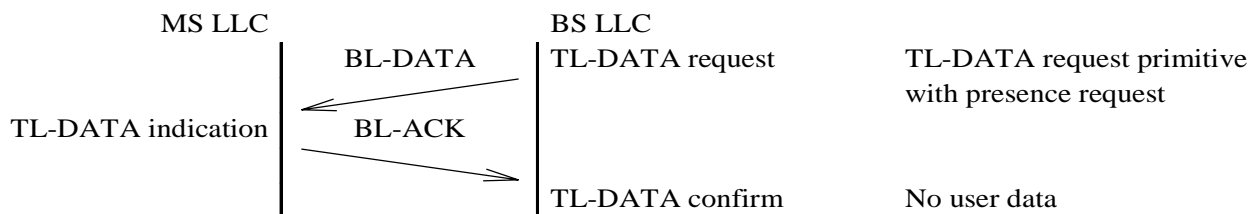


Figure 112: Basic link data transfer with presence indication

## 22.2.2 Advanced link

The advanced link provides two data transfer services, i.e. acknowledged and unacknowledged PDU transfer. The acknowledged data transfer can be used for point-to-point communication and the unacknowledged data transfer is intended to be used for point-to-multipoint communication, but may also be used for point-to-point information transfer on the downlink. Both services of the advanced link need to be set-up before they can be utilized. The life of an advanced link comprises a connection set-up, data transfer and connection release. The life time of an advanced link may be limited or unlimited. After cell reselection, depending on the capabilities of the MS and SwMI, the advanced link may be reconnected, with the same parameters (e.g. QoS, timers, counters) as were used on the previous cell.

The advanced link protocol can send multiple TL-SDUs before an acknowledgement shall be sent or is received. The transmitting station may send up to N.272 TL-SDUs before requesting and receiving a specific acknowledgement. The LLC may re-send TL-SDUs under a request from the receiving LLC entity or due to a lack of an acknowledgement.

The advanced link segments TL-SDUs which are too long to be carried in one MAC transmission unit (MAC block), and applies automatic selective re-transmission to badly received segments.

### 22.2.2.1 Setting up the connection mode (AL-SETUP PDU)

The advanced LLC link connection for acknowledged service shall be negotiated between the two LLC entities as described in figures 113 to 118 inclusive. Either the MS or BS may initiate the advanced link connection set-up. A new connection set-up during an already existing connection overrides it and performs a link reset. The resulting connection mode advanced link may coexist with an unacknowledged advanced link, refer to clause 22.2.2.2.

The connection request contains all parameters for negotiation:

- the maximum length of the TL-SDU N.271;
- the allowed number of TL-SDU retransmissions before LLC gives up N.273;
- the LLC TL-SDU window size N.272;
- the number of retransmissions of a segment N.274 before LLC reports an error to the service user;
- the number of timeslots used per a TDMA frame N.264;
- the number of advanced link N.261 and the requested mean value for the data transfer throughput, (see note 1).

The negotiation uses AL-SETUP PDUs.

NOTE 1: These constants are part of the quality of service negotiation and are transmitted to the peer side. Depending on the mobile class and base station services, the peer entity may wish to respond with a lower quality of service or even refuse the connection set-up.

The resulting connection will support two-way exchange of information between the peer LLC entities.

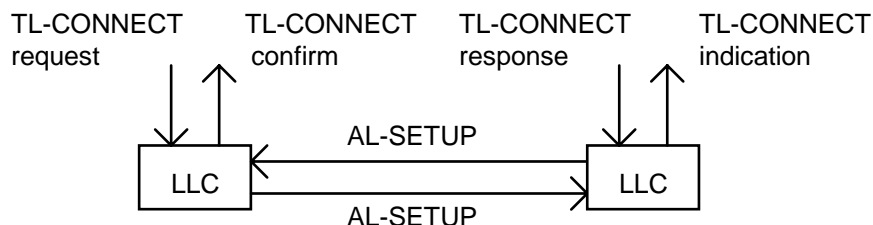


Figure 113: PDU setting up the advanced link



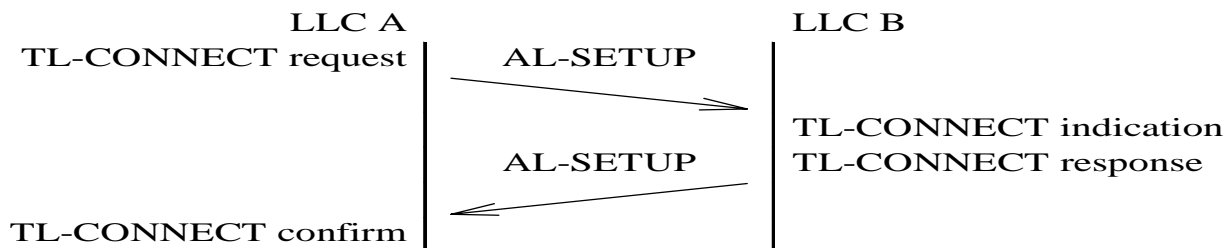
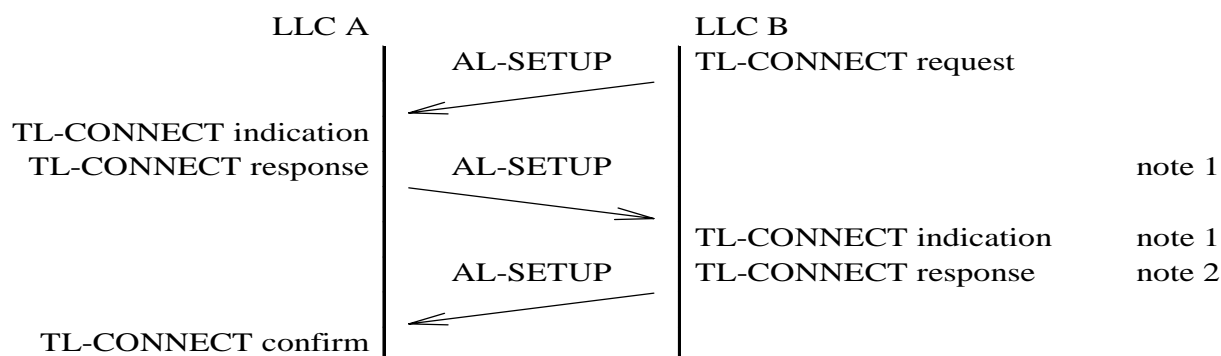


Figure 114: Advanced link set-up

NOTE 2: On establishment of an advanced link, the LLC shall prepare an AL-SETUP PDU with a setup report "service definition" if the corresponding advanced link is not already set-up. However, after advanced link reconnection, the MS LLC may think that there is already an established advanced link and therefore use a setup report value of "reset". Then the SwMI LLC entity should start normal connection establishment as if the received report were "service definition".



NOTE 1: Proposed QoS is not acceptable and a new QoS is proposed. The service negotiation may be performed as an direct negotiation between the LLC entities.

NOTE 2: The lower QoS is accepted.

Figure 115: Advanced link set-up to a lower quality of service

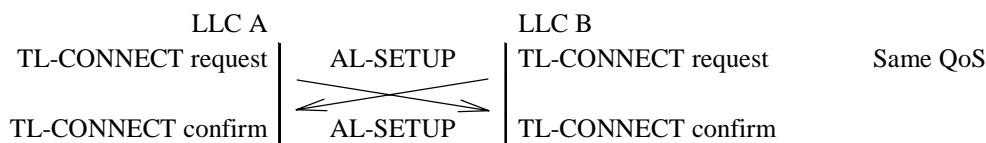
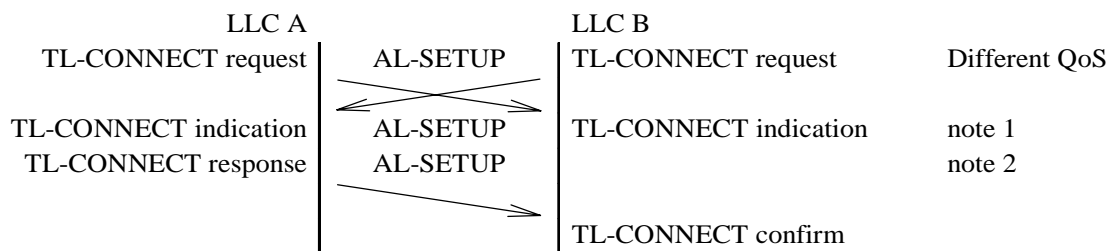


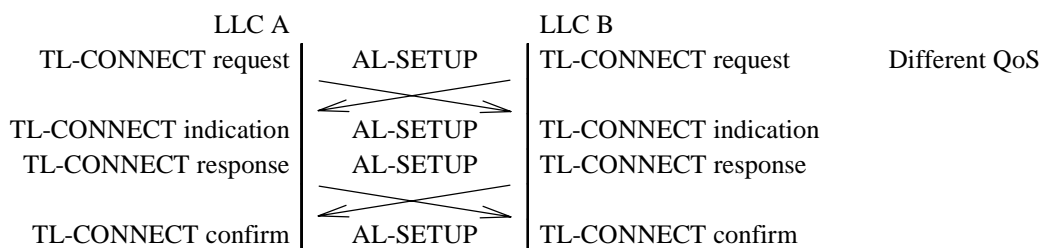
Figure 116: Simultaneous advanced link set-up



NOTE 1: TL-CONNECT primitive is shown as an indication due to differences in QoS.

NOTE 2: The LLC A confirms the lower QoS before the LLC B sends a new request.

**Figure 117: Simultaneous advanced link set-up with different QoS**



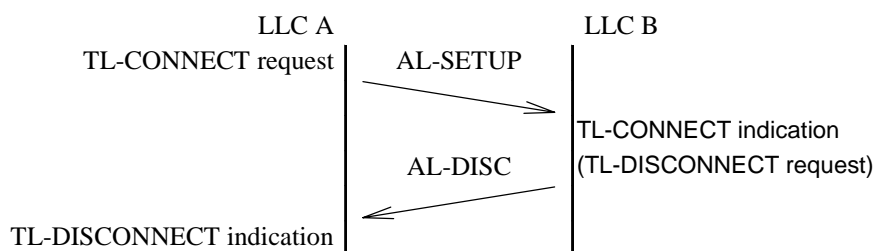
**Figure 118: Simultaneous advanced link set-up with different QoS**

Figure 114 presents a message sequence diagram for an advanced link set-up, when the LLC B accepts the quality of service proposed by the LLC A. If the receiving station replies with a lower parameter setting, the transmitting station shall confirm those lower values and use these negotiated parameters for the advanced links shown in figure 115. A receiving station shall not reply with higher parameter setting. On the other hand, the receiving station may refuse the connection by returning a TL-DISCONNECT request (AL-DISC PDU).

Figures 116 to 118 inclusive give examples of a set-up of the advanced link in special cases, when both LLC entities try to set-up a connection at the same time.

The initial connect request shall set the TL-SDU and segment counters to the default values prior to the first transmission in both information flow directions.

If the LLC cannot support the advanced link, it may send an AL-DISC PDU, see figure 119.



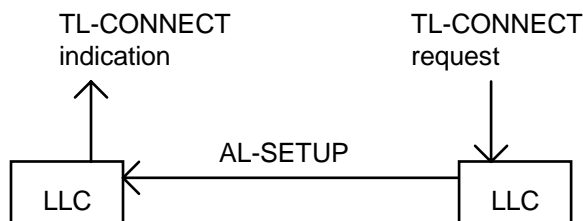
**Figure 119: Unsupported service indication**

#### 22.2.2.2 Setting up the unacknowledged transfer mode (AL-SETUP PDU)

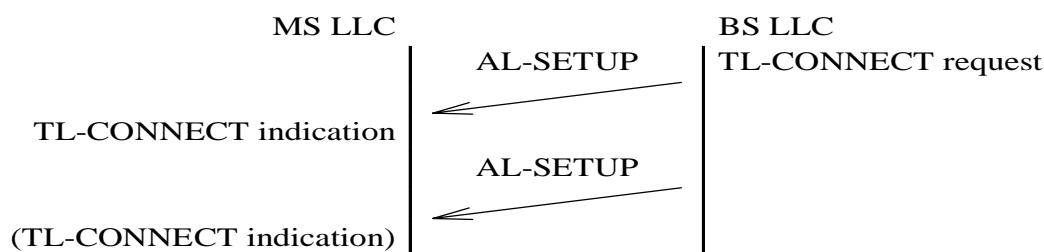
The advanced LLC link parameters shall be informed to the future participants of the unacknowledged transfer mode before the data transfer may commence successfully as described in figures 120 and 121. A new unacknowledged advanced link set-up during an already existing unacknowledged advanced link only modifies advanced link parameters without a reset functionality e.g. TL-SDU numbering shall continue without interruption. This set-up does not affect to the existing acknowledged advanced link service, if any, refer to clause 22.2.2.1.

The set-up indication contains all relevant parameters for the unacknowledged advanced link: the maximum length of the TL-SDU N.271, the maximum number of TL-SDU retransmissions N.282, the LLC TL-SDU window size N.281. The AL-SETUP PDU transmits these parameters. The AL-SETUP PDU may be sent several times (N.282+1 times) to increase the probability of correct reception. The further connection attempts for the same link are not passed to the service user unless the parameters in the following AL-SETUP PDUs changes.

The resulting unacknowledged advanced link will support one-way exchange of information from the entity which sends the set-up information to the other peer LLC entities. The receiving entity may not be capable to conform to the selected parameters and may neglect the set-up.



**Figure 120: Unacknowledged transfer mode set-up of the advanced link**



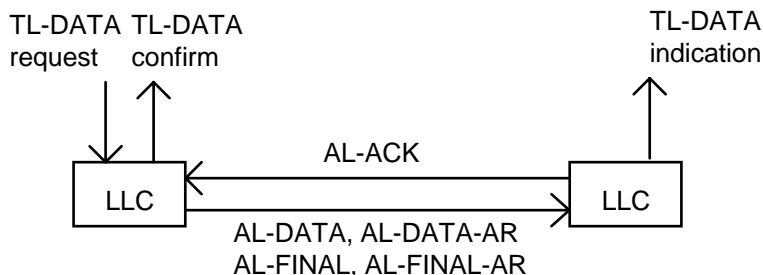
**Figure 121: Unacknowledged transfer mode set-up of the advanced link**

The unacknowledged advanced link entities shall set the TL-SDU and segments counters to the default values prior to the first transmission.

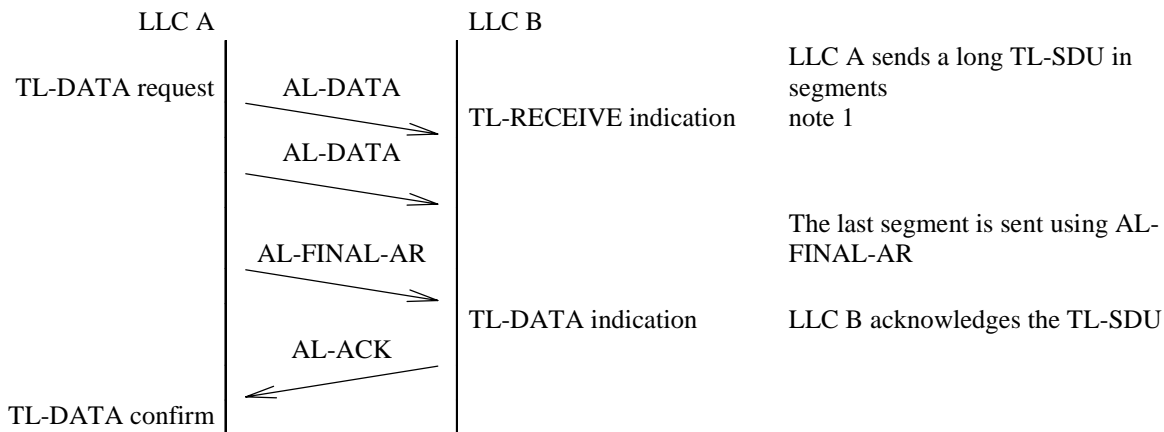
### 22.2.2.3 Data exchange in the connection mode (AL-DATA PDU)

After the connection set-up the advanced LLC link is ready for a two-way exchange of information between the two peer LLC entities although actual information flow could be unidirectional and the other direction is used only for acknowledgements. The information flows in both directions (uplink and downlink) are independent of each other. Each AL-DATA PDU contains 2 numbers, the actual TL-SDU number N(S) and the absolute position of the segment inside the TL-SDU called segment sequence number S(S). The segment sequence number is used in selective re-transmission in the AL-ACK PDU.

Data transfer in the advanced LLC link can be either unidirectional or bidirectional. In both cases data sending and data acknowledgements use same PDUs and protocol. In the first case, the transfer flow is shown in figures 122 and 123. In this example LLC A sends a segmented TL-SDU using AL-DATA PDUs and marks the last segment of the TL-SDU by using an AL-FINAL-AR PDU. In reply to the AL-FINAL-AR PDU the receiving LLC shall generate an acknowledgement using an AL-ACK PDU. The sending LLC informs the service user of the correct transfer of the layer 3 TL-DATA by issuing a TL-DATA confirm when a whole TL-SDU has been acknowledged. The receiving SwMI LLC entity informs the service user of the incoming of data by issuing a TL-RECEIVE indication primitive.



**Figure 122: PDU exchange in a unidirectional transfer**

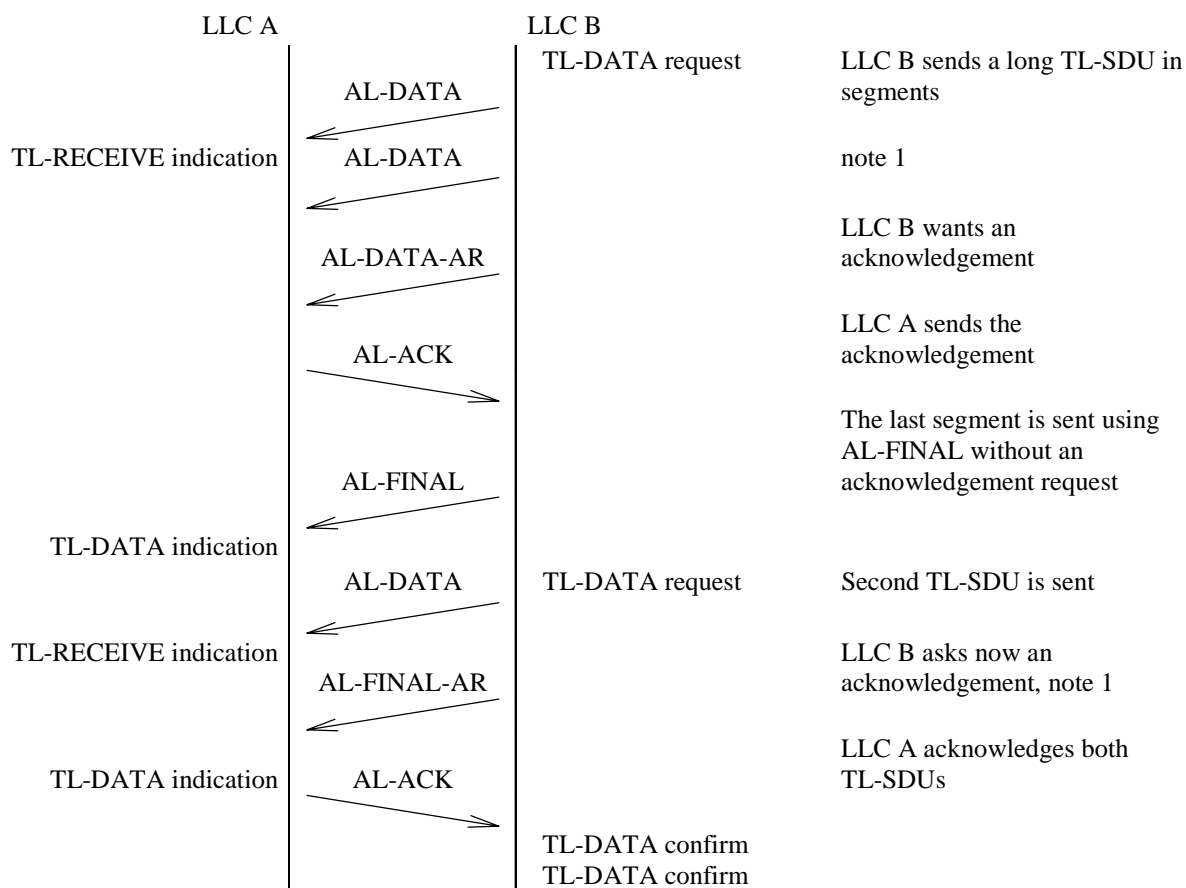


NOTE: LLC B refers to SwMI LLC entity in this figure. Exact mechanism when to send this primitive is outside the scope of the present document.

**Figure 123: PDU exchange in a unidirectional transfer**

The sending LLC entity may request an acknowledgement from the peer entity at any time by using AL-DATA-AR or AL-FINAL-AR PDUs in place of the AL-DATA and AL-FINAL PDUs respectively. The sender may continue transmission of data without waiting for the requested acknowledgements, if allowed by the SDU window size. In figure 124 the LLC B asks an acknowledgement in the middle of sending a TL-SDU and later does not request an immediate acknowledgement to the complete TL-SDU.

The receiver may send an AL-ACK PDU at any time in addition to the requested acknowledgements, see also clause 22.2.2.7.



NOTE: LLC A refers to SwMI LLC entity in this figure. Exact mechanism when to send this primitive is outside the scope of the present document.

Figure 124: A longer PDU transfer

An example of bidirectional information transfer flow is shown in figures 125 and 126. The LLC A sends a message to the LLC B and the LLC B responds with another message. The LLC A starts the sending by a segmented TL-SDU using AL-DATA PDUs and marks the last segment of the TL-SDU by using AL-FINAL-AR PDU. The LLC B delivers the received TL-SDU to the service user as a TL-DATA indication primitive. The LLC B generates an acknowledgement AL-ACK PDU as a response to the AL-FINAL PDU. The acknowledged TL-SDU shall be indicated to the sending service user by a TL-DATA confirm primitive.

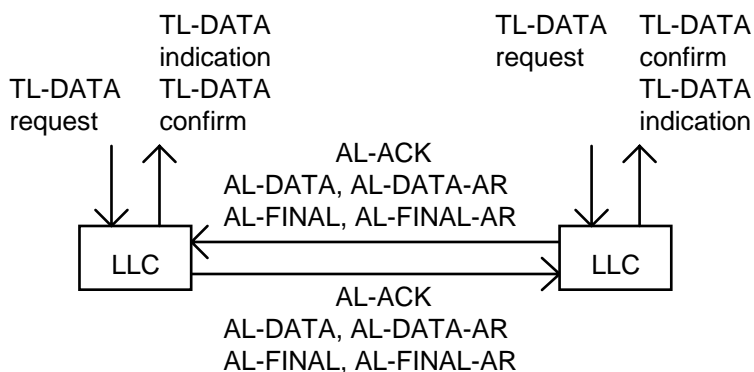
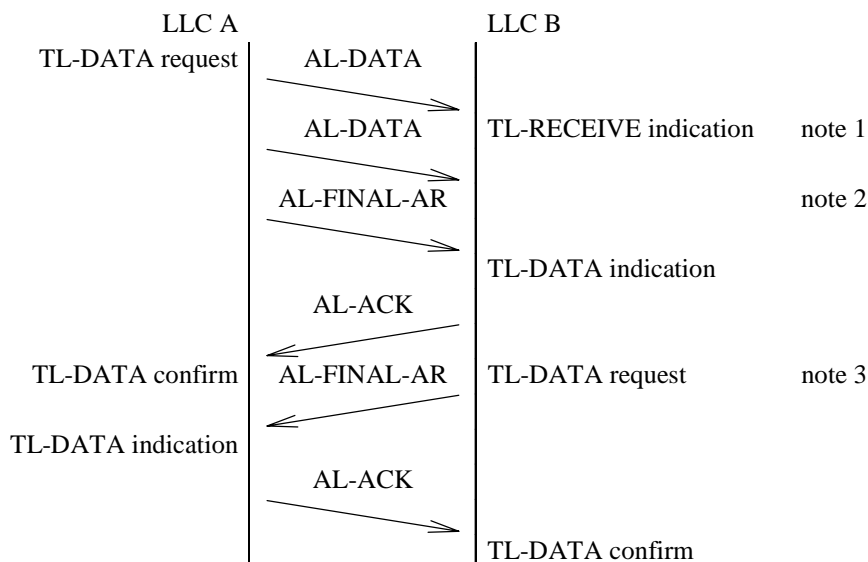


Figure 125: Bi-directional data transfer



- NOTE 1: LLC B refers to SwMI LLC entity in this figure. Exact mechanism when to send this primitive is outside the scope of the present document.
- NOTE 2: The last segment is sent using AL-FINAL-AR.
- NOTE 3: LLC B sends a responding or independent TL-SDU.

**Figure 126: Bi-directional PDU transfer**

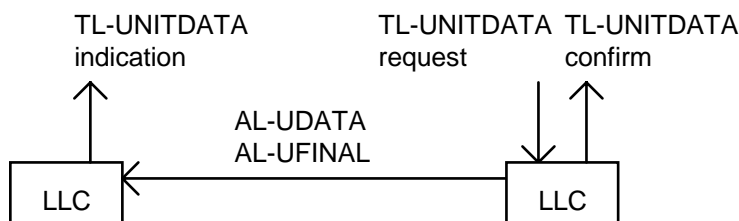
The LLC can accept more than one TL-SDU for sending before completing the transfer of the previous TL-SDU. The LLC may also modify the sending order of TL-SDUs depending on the priorities of those SDUs, but all already started transmissions needs to be completed before a new higher priority TL-SDU (non pre-emptive) may be transferred successfully. The LLC entity could also start sending of TL-SDUs at any time independently of the state of the other transfer direction.

Pre-emptive priority transmissions across an advanced link may reset the link to get fast access, This action may corrupt the ongoing lower priority transmission.

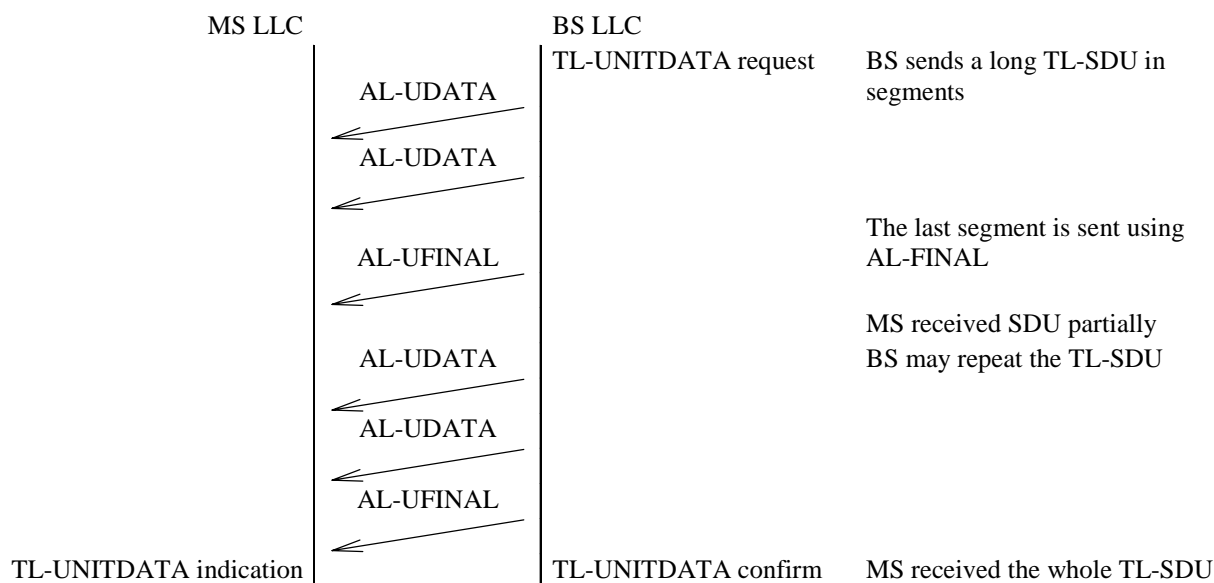
#### 22.2.2.4 Data exchange in the unacknowledged transfer mode (AL-UDATA PDU)

After the unacknowledged data transfer set-up the advanced LLC link is ready for a one-way exchange of information. The service user data is transmitted in AL-UDATA PDUs. The AL-UDATA PDU contains two numbers: the actual TL-SDU number N(S) and the absolute position of the segment inside the TL-SDU called segment sequence number S(S). The segment sequence number is used in the rebuilding of the received TL-SDU from segments. The data transfer flow is shown in figures 127 and 128. In this example BS LLC sends a segmented TL-SDU using AL-UDATA PDUs and marks the last segment of the TL-SDU by using an AL-UFINAL PDU. The BS may send TL-SDU several times up to maximum retransmissions (N.282) to increase the reception probability (and using the same segmentation for each repetition).

The receiving LLC entity delivers TL-SDU to the service user in a TL-UNITDATA indication. The sending entity may inform the completion of all repetitions to the service user using an informal TL-UNITDATA confirm primitive.



**Figure 127: PDU sending in a unidirectional transfer**



**Figure 128: PDU sending in a unidirectional transfer**

The BS LLC may send repetitions of up to N.281 TL-SDUs in any order, but the oldest TL-SDU within that SDU-window with all repetitions shall be sent before a new TL-SDU may commence. The BS LLC may also modify the sending order of TL-SDUs depending on the priorities of those SDUs, but all already started transmissions needs to be completed or advanced link needs to be reset by setting up a new unacknowledged link, before a new higher priority TL-SDU may be started.

The receiving entity may combine segments from multiple transmissions of the same TL-SDU in order to reassemble a complete TL-SDU.

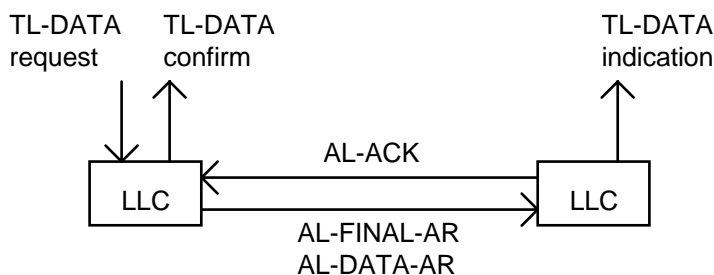
#### 22.2.2.5 Window mechanism

In the advanced link LLC protocol there is a window mechanism for TL-SDU transmissions. The window mechanism allows more than one TL-SDU and LLC data PDU respectively to be sent before required acknowledgements stop LLC transmissions. The TL-SDU window size N.272 is negotiated during the advanced link set-up, refer to clause 22.2.2.1.

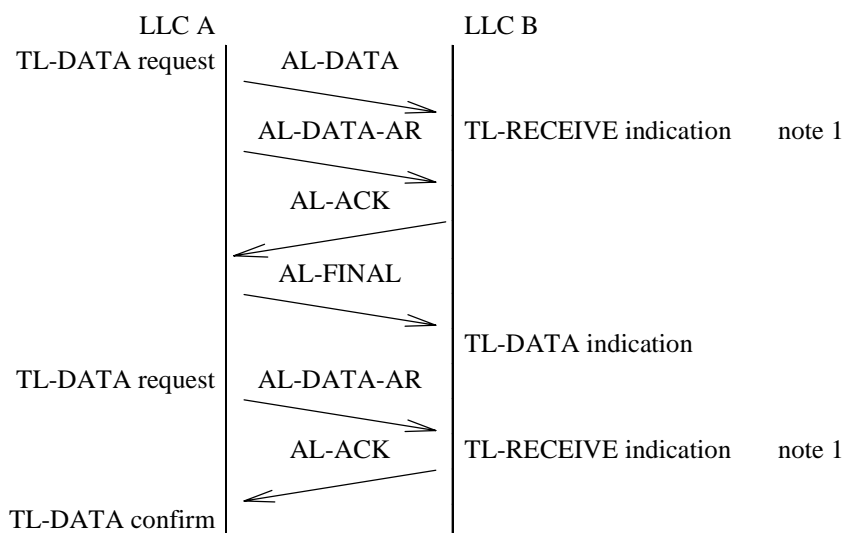
The receiving LLC entity may acknowledge each TL-SDU as soon as it is fully received, but the sending LLC entity may continue to send up to a total of N.272 TL-SDUs before receiving acknowledgements for the previous TL-SDUs. (For window size N.272 = 1, the receiving LLC entity acknowledges each TL-SDU before the sending LLC entity may continue with the next TL-SDU).

During a segment transmission the sending LLC entity may force a sending of an acknowledgement whenever it sends the last segment of a TL-SDU, which is sent as the AL-FINAL-AR PDU, refer to clause 22.2.2.3. The sending LLC entity may also request an acknowledgement at any time using an AL-DATA-AR PDU type, which also initiates an acknowledgement as soon as possible, see figures 129 and 130.

This window mechanism shall not be used for flow control purposes, refer to clause 22.2.2.7.



**Figure 129: PDU exchange for forced acknowledgement**



NOTE: LLC B refers to SwMI LLC entity in this figure. Exact mechanism when to send this primitive is outside the scope of the present document.

**Figure 130: Forced acknowledgement**

#### 22.2.2.6 Selective re-transmission of segments (AL-ACK)

The selective re-transmission is based on the segments (LLC PDUs) into which the transmitting LLC divides a TL-SDU for sending. The receiving LLC informs the transmitting LLC which segments are not received correctly, and then the transmitting LLC sends the missing segments in the later transmissions until the whole TL-SDU is received correctly as recognized by the MAC layer error detection. The whole TL-SDU may still be erroneous and the receiving entity shall ask a re-transmission, when an error in the TL-SDU is detected by the frame check sequence.

Figure 131 shows an example of a selective re-transmission sequence. Line a) of the figure shows three TL-SDUs, which the LLC divides into segments as shown in the line b). The end of each SDU is marked by "F" and the LLC sends that segment using a AL-FINAL PDU. The SDU window size is 2 in this example.

The transmitting LLC plans to send segments as shown on line b) of the figure and starts to send them in sequence using AL-DATA PDUs for all but the last one which it sends using AL-DATA-AR PDU marked by "A". The receiving LLC receives correctly segments 1, 2, 4, 5 from the first SDU as shown on line c), and sends the first acknowledgement (ACK) as requested by the sending entity. The acknowledgement contains bit maps as shown on line e) and corresponding segment numbers are shown on line f). The first part of the ACK (1/3) indicates the first segment, which is not received correctly, in this example segment number 3 in the first SDU and a bit map from that segment onwards. The acknowledgement tells that all segments before the 3rd segment of the first SDU (1/3) are received correctly and that segment 3 of the first SDU is not yet received correctly. Then the bitmap shows that segments 4 and 5 are received correctly.

The transmitting LLC then modifies its transmission and adds those segments, which were not acknowledged or sent i.e. 3 and 6 from the first SDU (1/3 and 1/6), before continuing transmission of new segments in this case from the second SDU. The last segment of the second SDU is sent as AL-FINAL-AR PDU marked "F/A". The second and third acknowledgements on line d) indicate that again segments 3 and 6 from the first SDU are not yet received correctly, but the second SDU is received totally and correctly (2/A). The transmitting LLC then re-sends segments 3 and 6 of the first SDU and cannot continue to the third SDU due to SDU window size of two in this example.

The receiving LLC misses again the segment number 3 of the first SDU as shown on line g) and the receiving LLC sends acknowledgement after receiving the 6th and final segment of the first SDU. The first acknowledgement indicates that only the third segment of the first SDU is not yet received correctly. The transmitting LLC then re-sends the missing segment of the first SDU and after receiving the second acknowledgement on the line h) can send the third SDU, which fits into the new SDU window. That SDU is received correctly as indicated by each segment CRC, but the total frame check sequence does not match and the receiving LLC sends an acknowledgement indicating a re-sending request (3/F) of the third SDU. After re-sending on line j) the third SDU is this time received correctly and acknowledged on line k) (3/A).



In this example the receiving LLC will deliver the first TL-SDU to the MLE only after receiving the second acknowledgement on the line i), which indicates that the first SDU is correctly received. The second SDU is already correctly received and acknowledged by the second acknowledgement on the line d), but the receiving LLC can not deliver it before the first SDU is received to keep SDUs in the correct sequence.

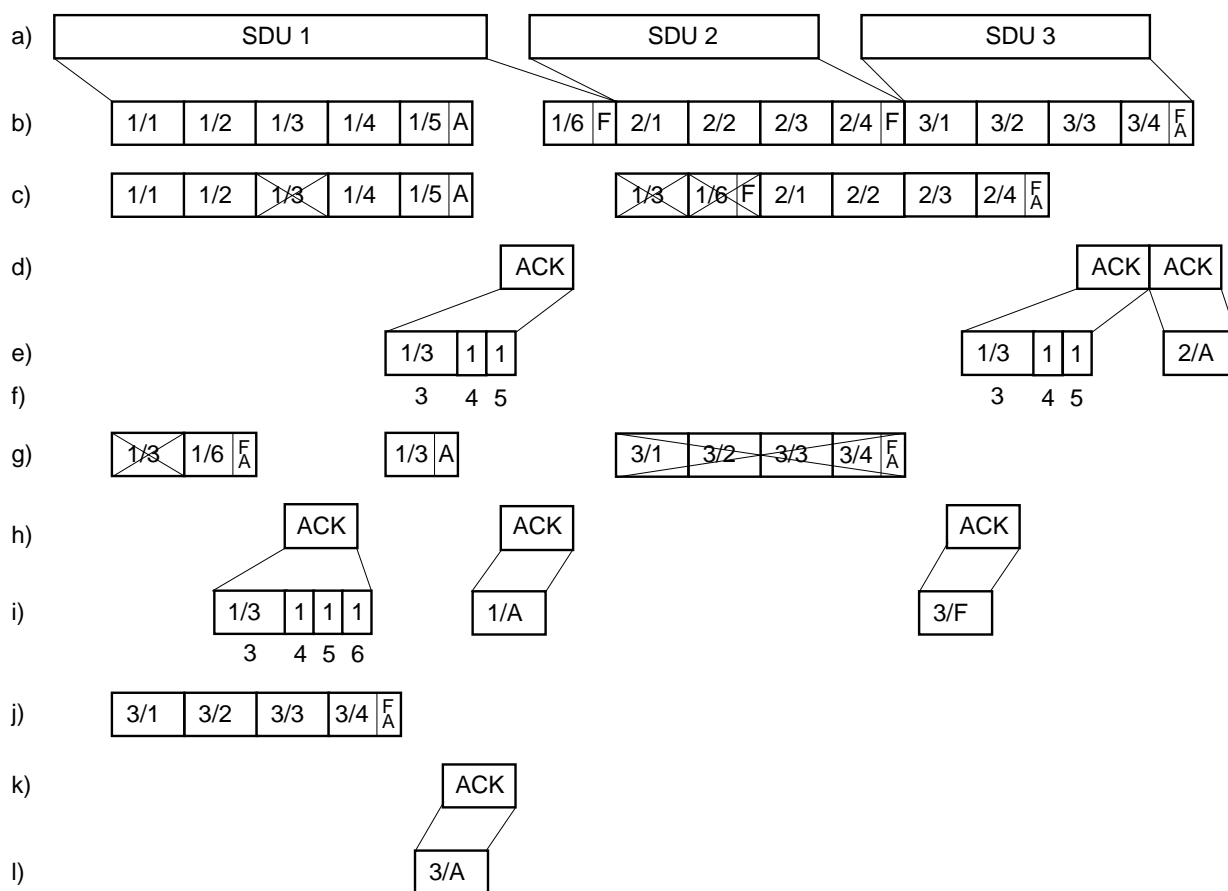


Figure 131: Selective re-transmission example

If the AL-FINAL-AR is lost and there is no more data to send or the transmission window is closed and the last acknowledgement is also lost, then the sending entity may repeat the whole last sending or only the segments which were sent with the acknowledgement request.

22.2.2.7 Flow control

The receiving advanced link entity may at any time request its peer entity to stop transmission of data PDUs by sending an AL-RNR PDU. The AL-RNR PDU replaces the AL-ACK PDU, when the receiver is not ready to receive new PDUs. The re-transmission of the segments or PDUs indicated in AL-RNR PDU shall continue. The data transmission may continue after the receiving entity has sent a AL-ACK PDU, refer to figures 132 and 133. The receiver not ready indication is valid from the last received AL-RNR PDU for the duration of T.271 s after which the transmitter may try to re-start data sending.

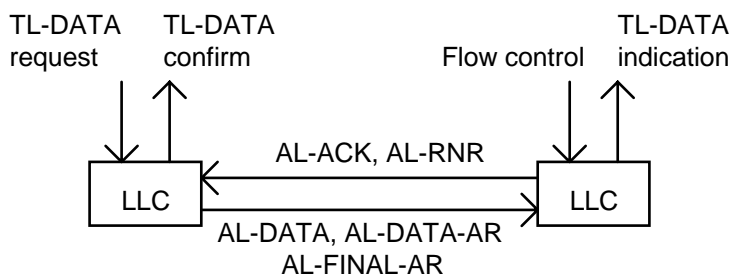
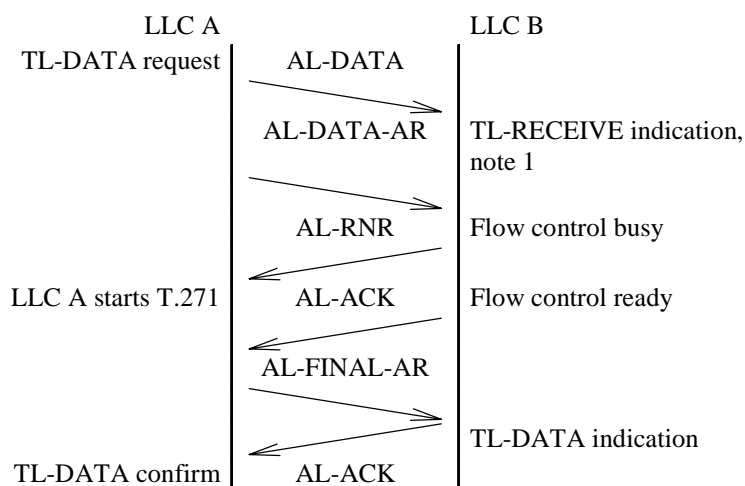


Figure 132: Flow control PDU exchange



NOTE 1: LLC B refers to SwMI LLC entity in this figure. Exact mechanism when to send this primitive is outside the scope of the present document.

**Figure 133: Flow control**

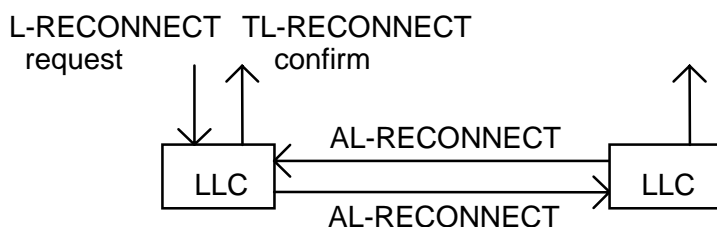
### 22.2.2.8 Connection reset

The connection reset may be performed using connection set-up procedure, refer to clause 22.2.2.1.

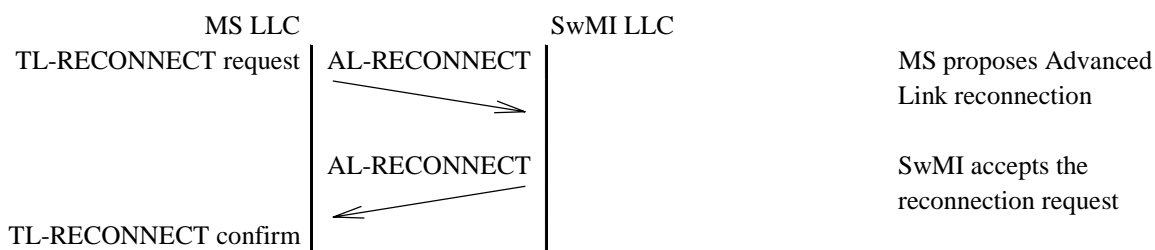
#### 22.2.2.8a Reconnecting the advanced link (AL-RECONNECT PDU)

Prior to performing a cell handover, the LLC service user may request that the advanced link is locally disconnected by using the TL-RELEASE request primitive. However, where the MS is involved in the transmission or reception of TL-SDU segments immediately prior to cell handover, the LLC service user may decide not to disconnect the advanced link but instead may request the LLC to reconnect the advanced link on the new cell by using TL-RECONNECT request primitive, when the SwMI supports or recognizes the advanced link roaming, and thus continue the transmission or reception of TL-SDU segments from where it finished on the previous cell. When the MS initiates a reconnection, see figures 133a and 133b, the timer T.265 (Reconnection waiting timer) shall be started at the TL-RECONNECT request. On reception of the AL-RECONNECT PDU, and where the reconnection has been successful as indicated by the reconnect report field value "success", the LLC shall send a TL-RECONNECT confirm to the service user to indicate the successful result of the reconnection, a TMC-CONFIGURE request to the MAC in order to accept the channel change when requested and the MS LLC may continue using the advanced link on the new cell without a reset.

On reception of the AL-RECONNECT PDU, and where the reconnection attempt has failed as indicated by the reconnect report field value "reject", or when timer T.265 has expired N.265 times (maximum number of reconnection retries), without success, then MS LLC shall consider that the reconnection of the advanced link has failed and inform the service user by a TL-RECONNECT confirm primitive with the reconnection result set to "reject" or "failed" respectively.



**Figure 133a: PDU exchange for reconnection the advanced link**

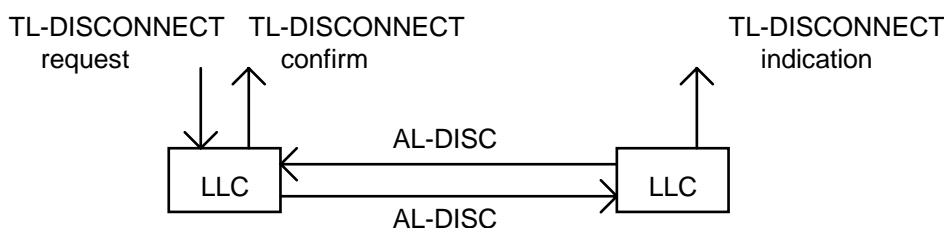


NOTE: The AL-reconnection protocol is unsymmetrical in contrast to other LLC protocol parts.

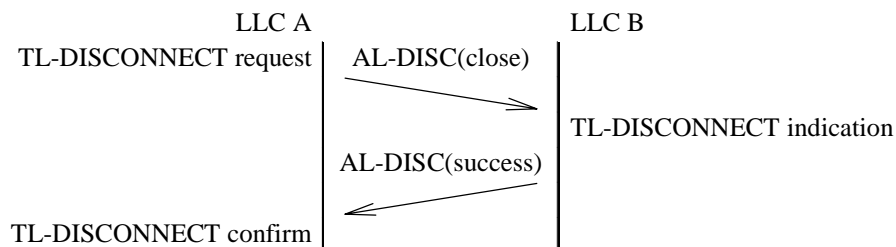
**Figure 133b: Reconnection of an advanced link**

### 22.2.2.9 Releasing the acknowledged advanced link (AL-DISC PDU)

The advanced link may be closed at any time by using the TL-DISCONNECT request primitive. Any on-going data transfer shall be stopped immediately with the possible result of data loss, refer to figures 134 and 135. When the LLC starts a disconnection, see figure 135, then the timer T.263 shall be started at the TL-DISCONNECT request. On a reception of AL-DISC or when timer T.263 has expired N.263 times without success, a TL-DISCONNECT confirm is given to the service user. The LLC shall discontinue to use the advanced link immediately at the reception of an AL-DISC PDU.



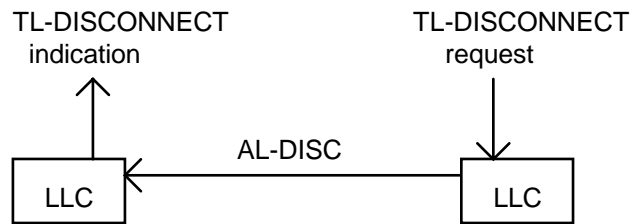
**Figure 134: PDU exchange for releasing the advanced link**



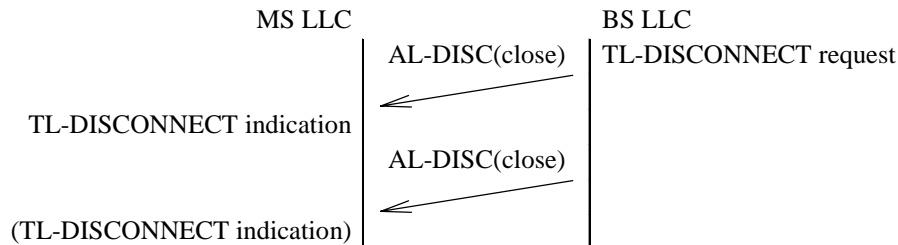
**Figure 135: Disconnection of an advanced link**

### 22.2.2.10 Releasing the unacknowledged advanced link (AL-DISC PDU)

The unacknowledged advanced link is suppressed by using the disconnect primitive, refer to figures 136 and 137. The AL-DISC PDU may be repeated to increase reception probability. The further disconnection attempts for the same link are not passed to the service user. Disconnection may occur at any time and after that instance that unacknowledged link does not support unacknowledged data transfer.



**Figure 136: PDU exchange for releasing the unacknowledged advanced link**



NOTE: AL-DISC may be repeated.

**Figure 137: Disconnection of an unacknowledged advanced link**

## 22.3 LLC procedures

In this clause the word "shall" is used with service primitives for traceability reasons in the protocol model, but the primitives are not testable and do not imply any implementation.

### 22.3.1 Common procedures for all services

This clause describes protocol procedures, which are used in all LLC services or which are common to all services.

#### 22.3.1.1 End-point identifiers and handle to the request

End-point identifiers between the service user (MLE) and LLC shall serve to distinguish between the multiple concurrent services, e.g. among several advanced links and their associated basic links. These identifiers may be local. The endpoint identifiers between LLC and MAC maintain this distinction, i.e. the LLC shall associate the service to a particular link while the MAC shall associate the link to a particular timeslot number or numbers for multislot service (offering more throughput). Acknowledgement shall use the same end-point identifier in the LLC.

When the LLC receives a service request primitive (except TL-RELEASE request) from the MLE, the primitive includes a local identifier for the service request, referred to as the "handle to the request". The handle should be retained locally and used for identifying subsequent related service primitives. It refers to all actions required in the LLC to accomplish the request. LLC shall also pass the handle to the request parameter to the MAC layer. In a similar way the MAC associates a handle to the request to each data request and the LLC shall use that handle to the request when it refers to that transmission.

The LLC shall generate a handle to the request for acknowledged data transfer service indication primitives (TL-DATA indication) and retain it for the corresponding response primitive (TL-DATA response).

The handle to the request shall cease to exist, when the requested or offered service is completed successfully or unsuccessfully.

### 22.3.1.2 Addressing

At the transmitting LLC entity, the LLC shall get the address in use as a parameter from the service user in the primitive types request and response and shall give it to the MAC as a parameter. At the receiving entity, it shall get the address in use from MAC and shall give it to the service user in the primitive types indication and confirm as a parameter. The LLC shall copy the same address parameters as in the corresponding TMA-UNITDATA indication primitive to the acknowledging TMA-UNITDATA request primitive.

NOTE: ITSIs and GTSIs in an MS are independent of each other and LLC services recognize addresses to allow concurrent basic or advanced link services. The present document does not describe how addresses affect to the LLC implementation.

If layer 3 response address is different to the address in TMA-UNITDATA indication then the layer 3 response shall not be piggybacked on the layer 2 acknowledgement.

### 22.3.1.3 User data buffering

The sending LLC entity shall buffer TL-SDUs in order to offer re-transmission until individually marked as correctly received, or the maximum number of retransmissions is exceeded or TL-SDU is cancelled by the service user or, in addition in the case of an advanced link, the link is either disconnected or re-set. When transmitting segmented TL-SDUs, the segmentation and the segments shall be preserved for further retransmissions until the TL-SDU is completely acknowledged or maximum number of retransmissions is exceeded.

The LLC sub-entities shall update their part of the DATA-IN-BUFFER signal so often, that the MAC layer can update resource requests in time to prevent unnecessary breaks and random accesses in uplink data transfer, see clause 22.3.1.7.

The amount of data that may be buffered for transmission inside LLC layer is implementation dependent. This model deletes all not yet transmitted data in the advanced link buffers, when the advanced link is reset by a new set-up.

### 22.3.1.4 Cancelling SDU transmission

This procedure is local to the MS, but affects the data transfer over the air interface.

On the basic link the service user may cancel an ongoing transmission of a TL-SDU. On the reception of a TL-CANCEL request from the service user the LLC shall delete the TL-SDU indicated by the handle to the request parameter in the TL-CANCEL request, if that TL-SDU is still in the transmission buffer and no part of it is transferred to the MAC layer, and shall indicate the cancellation to the service user in a TL-REPORT indication (aborted, TL-SDU not completely sent). Otherwise LLC shall forward cancellation request to the MAC as a TMA-CANCEL request. If the corresponding MAC TMA-REPORT indication (aborted, TM-SDU not completely sent) shows that the MAC has aborted the transmission and the TM-SDU has not been completely sent, then the LLC shall delete the corresponding TL-SDU from the sending buffer and shall indicate the cancellation to the service user in a TL-REPORT indication (aborted, TL-SDU not completely sent). If the MAC has sent the whole SDU containing the TL-SDU for which a cancellation was requested, then the MAC will indicate with a TMA-REPORT indication (aborted, TM-SDU sent at least once), that the whole TL-SDU is sent. The LLC shall then delete the corresponding TL-SDU from the sending buffer and indicate in a TL-REPORT indication (aborted, TL-SDU sent at least once) to the service user, that the DLL has aborted sending actions, but the TL-SDU has been sent at least once.

NOTE 1: If the LLC has transferred the SDU to the MAC more than once, then it is the LLC's responsibility to issue the correct TL-REPORT indication to the higher layers, taking into account also the results of the previous transmission attempts.

In the advanced link the DLL can cancel the transmission of the TL-SDU only if the first segment has not been sent at all. On the reception of a TL-CANCEL request from the service user the LLC shall delete from the transmission buffer a TL-SDU, if sending has not started and indicate in a TL-REPORT, that cancellation is completed and the TL-SDU is not sent. If the LLC has delivered only the first segment of the TL-SDU to the MAC and that segment is not yet acknowledged, then the LLC shall forward cancellation request to the MAC as a TMA-CANCEL request. If the corresponding MAC TMA-REPORT indication shows that the MAC has aborted the transmission and the TMA-SDU corresponding to the first segment has not been sent at all, then the LLC shall delete the corresponding TL-SDU from the sending buffer and shall indicate the successful cancellation (the TL-SDU is not completely sent) to the service user in a TL-REPORT indication.

If the TMA-REPORT indication shows that the MAC has sent the TMA-SDU corresponding to the first segment at least once, then the LLC shall indicate with a TL-REPORT indication (layer two transmission activities continuing) and continue TL-SDU transmission.

The advanced link service user may also stop transmission of a TL-SDU by disconnecting or resetting by a new set-up the corresponding advanced link, refer to clauses 22.3.3.3 and 22.3.3.1.

NOTE 2: The DLL always responds to a TL-CANCEL request with a TL-REPORT indication.

### 22.3.1.5 Extended error protection

An extended error detection (FCS) shall be offered as a selectable part of the service on basic link and as a mandatory part of the service on the advanced link. When appropriate the sending LLC shall calculate over the TL-SDU a FCS and shall append it to the TL-SDU.

When a FCS is appended to the TL-SDU, then the receiving LLC entity shall test the received TL-SDU against the FCS to detect whether errors have been introduced into the TL-SDU during transmission. When the receiving LLC detects errors in the received TL-SDU, the LLC shall not pass the erroneous TL-SDU to the service user, but instead the LLC shall discard the erroneous TL-SDU and enforce an SDU re-transmission if appropriate.

The FCS is defined in annex C.

### 22.3.1.6 Timers and counters

In the protocol description, timers and counters are referred either by their names or by their value symbols or both e.g. set-up waiting timer T.261. Stopping of timers and counter re-settings are shown only when implicit reasons are not obvious. This protocol does not define or restrict any implementation of timers or counters.

### 22.3.1.7 Formatter protocol

The sending formatter controls the transmission order of the LLC PDUs. It delivers LLC PDUs to the MAC conceivably according to the optional priority order of the PDUs using TMA-UNITDATA request primitives. The receiving formatter identifies LLC PDU headers in the MAC TMA-UNITDATA indication primitives and delivers the PDUs to the corresponding LLC entities.

NOTE: PDU priority is considered as an optional feature and it applies to all LLC data sending entities.

#### 22.3.1.7.1 MS formatter receiving entity

Upon reception of a TMA-UNITDATA indication primitive the formatter shall decode the PDU type. The formatter shall route the corresponding PDU according to the PDU type, endpoint identifier and address to the appropriate LLC protocol sub-entity instance. If the formatter recognizes a PDU, which is not valid for the current composition of LLC entities, then the formatter shall discard the PDU without any further actions.

#### 22.3.1.7.2 MS formatter sending entity

The LLC shall indicate to the MAC the availability of data to be transmitted with the DATA\_IN\_BUFFER signal, which specify the total amount of all outstanding data of all LLC sub-entities (including pending acknowledgements) and the highest priority and stealing permission for that data. In the case of an emergency message the formatter should deliver the corresponding DATA\_IN\_BUFFER signal to the MAC before a possible TMA-CANCEL request so that MAC could make a new resource request during the cancel process.

Upon reception of MAC-READY from MAC, the LLC shall decide which of the outstanding PDUs have to be sent, depending on the protocol needs and the size of the next MAC block. Within the same service, acknowledgements shall be sent prior to any data PDUs. Basic link PDUs shall be sent before advanced link PDUs unless the priority of the advanced link PDUs is higher than the priority of the basic link PDUs. The LLC shall deliver the PDU to the MAC using a TMA-UNITDATA request primitive containing the handle to the request parameter from the corresponding TL-service primitive for further referencing.

There may be multiple MAC-READY and TMA-UNITDATA request exchanges, if MAC is performing an association of LLC PDUs into one MAC block.

The MAC will select the relevant means to transfer the information, i.e. either by random or reserved access or frame stealing, as appropriate based on the selected priority and stealing permission parameter.

### 22.3.2 Basic link procedures

The basic link shall offer two services, acknowledged and unacknowledged data transfer. The acknowledged service supports also a data response service primitive for call set-up optimization. The data with the response primitive is transmitted using an acknowledge message without an explicit acknowledgement, see clause 22.2.1.1.

The basic link LLC protocol of the MS is modelled by two processes, BL\_LLC\_MS and Formatter, the latter being common with the advanced links, refer to figure 102.

The present document models the numbering of TL-SDUs and acknowledgements and local function indicators by local variables. Each basic link shall employ separate sets of variables, parameters and timers. At the sending side variables and main parameters are:

- N(S) TL-SDU number in the sent data PDUs;
- N(R) TL-SDU number in the received acknowledgement PDUs;
- V(S) the next TL-SDU number to be sent or to be re-sent;

and at the receiving side:

- N(S) TL-SDU number in the received data PDUs;
- N(R) TL-SDU number in the sent acknowledgement PDUs;
- V(R) the last received TL-SDU number.

Timers and constants are defined in annex A.

NOTE: This protocol description is valid for one basic link, which uses one address.

#### 22.3.2.1 Establishment of information transfer in basic link

No explicit establishment is required for the basic link. At least one basic link shall be available, when the MS is synchronized to a BS. When there is no advanced link nor circuit mode connection, then there is a single basic link on the corresponding control channel. When there are any defined advanced links or circuit mode connections, then there is one basic link per each advanced link and circuit mode connection. If an advanced link uses same physical resource allocations as a circuit mode connection, then there is only one basic link associated with the pair.

The MS shall keep all basic links that are not removed in the physical resource allocation, if the MS is capable of operation on concurrent channels, see clause 23. The BS may allocate e.g. the first advanced link and the basic link associated to a circuit mode call so that the previous basic link on the initiating control channel is released.

After power on or in the first transmission, when roaming or migrating to a new BS the MS LLC shall start TL-SDU numbering from "0" by setting local variable V(S) = 0 .

#### 22.3.2.2 Quality of service selection

The service user shall define the quality of service for each message by selecting a basic link and the primitive type either TL-DATA request or TL-UNITDATA request and by selecting the parameters in that primitive, see definition of parameters in clause 20. The undetected message error rate shall be defined by selecting the use of the FCS. The TL-PDU sending order in the selected basic link and in relation to the concurrent advanced link shall be defined by the conceivably requested priority, which may change the transmission order of TL-SDUs. The priority shall affect the transmission of a already started TL-SDU sending only if the highest priority (emergency) is used and the sending of the current TL-SDU is destroyed by cancellation.

NOTE: The maximum data transfer throughput of an associated basic link is defined by the associated advanced link or circuit mode call.

### 22.3.2.3 Acknowledged data transmission in basic link

The acknowledged data transmission is modelled by the states in the sending process:

- TX\_READY transmitter is ready to send next TL-SDU;

and in the receiving process:

- RX\_READY receiver is ready to receive data from the MAC.

Each acknowledged information transfer is identified by a TL-SDU number N(S) both in BL-DATA and BL-ADATA PDUs. The acknowledgement contains the number N(R) of the correctly received TL-SDU both in BL-ACK and BL-ADATA PDUs. In addition, the receiver has the possibility to send data in a TL-DATA response primitive together with the acknowledgement without a sequence number. The N(R) in that acknowledgement marks the TL-SDU sent using an acknowledgement BL-ACK PDU.

The LLC process may receive:

- service user service primitive:
  - a) a TL-DATA request primitive (handle to the request) and then the LLC shall:
    - i) issue an immediate TL-REPORT indication confirming the handle to the request parameter;
    - ii) calculate FCS, when requested, and append it to TL-SDU;
    - iii) place the TL-SDU into transmission buffer according to the indicated priority;
    - iv) indicate new data in the transmitting buffer to the formatter using DATA\_IN\_BUFFER signal;
    - v) in the case of a TL-DATA request with the emergency priority and if there is an ongoing lower priority TL-DATA (or TL-UNITDATA) PDU in transmission on that basic link at the MAC layer, then the LLC may deliver a TMA-CANCEL primitive via formatter to the MAC, see clause 22.3.1.4. The LLC shall not cancel a BL-ACK PDU with or without service user data. The LLC may cancel a BL-ADATA PDU and memorize the N(R) in it.
  - b) a TL-DATA response primitive to the TL-DATA indication primitive (handle to the request) before the corresponding acknowledgement is sent and then the LLC shall:
    - i) calculate FCS, when requested, and append it to TL-SDU;
    - ii) format a BL-ACK PDU ( $N(R) = V(R)$ ) with the (optional) TL-SDU from the TL-DATA response primitive;
    - iii) inform the formatter using DATA\_IN\_BUFFER signal.
  - c) a TL-DATA response primitive (handle to the request) after sending the corresponding BL-ACK or BL-ADATA PDU, then the LLC shall:
    - i) issue an immediate TL-REPORT indication confirming the handle to the request parameter (from the TL-DATA response primitive) as if it has received a TL-DATA request primitive;
    - ii) calculate FCS, when requested, and append it to TL-SDU;
    - iii) place the TL-SDU into transmission buffer according to the indicated priority;
    - iv) indicate new data in the transmitting buffer to the formatter using DATA\_IN\_BUFFER signal;
    - v) in the case of a TL-DATA response with emergency priority and if there is an ongoing lower priority TL-DATA (or TL-UNITDATA) PDU in transmission on that basic link at the MAC layer, then the LLC may deliver a TMA-CANCEL primitive via formatter to the MAC, see clause 22.3.1.4. The LLC shall not cancel a BL-ACK PDU (which in this situation should be without user data).



- local indications:
  - d) a MAC-READY indication from the formatter and then:
    - if a BL-ACK PDU is ready due to a TL-DATA response, then the LLC shall issue it to the formatter with an acknowledgement number  $N(R) = V(R)$ ;
    - if there is a waiting acknowledgement and a TL-DATA request available, then the LLC shall:
      - i) set  $N(S) = V(S)$  for the TL-SDU to be sent;
      - ii) set  $N(R) = V(R)$  for the waiting acknowledgement;
      - iii) form the corresponding BL-ADATA PDU and issue it to the formatter;
    - if the size of the TL-DATA plus the size of the BL-ADATA LLC header exceeds the size of the TM-SDU in this MAC block, then the LLC shall issue a BL-ACK PDU with an acknowledgement number  $N(R) = V(R)$  to the formatter without any service user data and send the TL-SDU using BL-DATA PDU;
    - if there is a waiting acknowledgement and neither a TL-DATA response nor a TL-DATA request available, then the LLC shall issue a BL-ACK PDU with an acknowledgement number  $N(R) = V(R)$  to the formatter without any service user data;
    - if there is no waiting acknowledgement but a TL-SDU is available, then the LLC shall set  $N(S) = V(S)$  for the TL-SDU to be sent, form the corresponding BL-DATA PDU and issue it to the formatter.
  - e) a TMA-REPORT indication (handle to the request) and if it is due to a BL-DATA or BL-ADATA PDU, then the LLC shall memorize it;
  - f) a TMA-REPORT indication (one of the complete TM-SDU transmission indications) and if it is due to a PDU which contained service user data in either a BL-DATA or BL-ADATA PDU and the PDU transmission was successful and complete transmission by random access or complete transmission by reserved access or stealing, then the LLC shall start the re-try timer T.251; and in any case, if this is the first transmission of the TL-SDU, then the LLC shall issue a TL-REPORT indication (first complete transmission) to the service user;
  - g) a TMA-REPORT indication (random access failure) and if it is due to a PDU which contained service user data, then the LLC shall inform the service user of unsuccessful transmission by TL-REPORT primitive (failed transfer), and delete the corresponding TL-SDU from the sending buffer. If the report was due to a BL-DATA or BL-ADATA PDU, the LLC shall increment  $V(S)$ ;
  - h) a TMA-REPORT indication (fragmentation failure) and:
    - if it is due to a BL-ACK PDU, then the LLC shall discard the optional TL-SDU;
    - if the report is due to a BL-DATA or BL-ADATA PDU and the number of allowed retransmissions N.252 of the corresponding TL-SDU is not exceeded, then the LLC shall keep the TL-SDU for re-transmission and inform the formatter by a DATA\_IN\_BUFFER signal; or
    - otherwise the LLC shall inform the service user of unsuccessful transmission by TL-REPORT primitive (failed transfer), increment  $V(S)$  and delete TL-SDU from the sending buffer.
  - i) re-try timer T.251 expires and
    - if the number of allowed retransmissions N.252 is not exceeded, then the LLC shall keep the TL-SDU in the sending buffer for re-transmission and inform the formatter by a DATA\_IN\_BUFFER signal; or
    - otherwise the LLC shall inform the service user of unsuccessful transmission by TL-REPORT primitive (failed transfer), increment  $V(S)$  and delete TL-SDU from the sending buffer;
- PDU from the peer entity:

- j) a BL-ACK and then:
- if there is a TL-SDU waiting for a re-transmission in the sending buffer, then:
  - if the TL-SDU number (in the BL-ACK PDU)  $N(R) = V(S)$ , then the LLC shall confirm the success of the transmission to the service user by a TL-DATA confirm (successful transfer) primitive and deliver the contained TL-SDU, if any upon condition that the FCS calculation is successful in case the optional FCS is used, increment  $V(S)$ , delete the TL-SDU waiting for a re-sending from the sending buffer and stop the re-try timer T.251; or
  - if the TL-SDU number (in the BL-ACK PDU)  $N(R)$  is not equal to  $V(S)$ , then the LLC shall deliver contained TL-SDU, if any upon condition that the FCS calculation is successful in case the optional FCS is used, using TL-DATA indication; and
  - if the number of allowed retransmissions N.252 of the TL-SDU is not exceeded, then the LLC shall keep the corresponding TL-SDU in the sending buffer for re-transmission and inform the formatter by the DATA\_IN\_BUFFER signal; or
  - if the number of allowed retransmissions N.252 of the TL-SDU is exceeded, then the LLC shall inform the service user of unsuccessful transmission by a TL-REPORT primitive (failed transfer), increment  $V(S)$ , stop re-try timer T.251 and discard the corresponding TL-SDU from the sending buffer;
  - if there is no TL-SDU waiting for a re-transmission in the sending buffer, then the LLC shall deliver contained TL-SDU, if any upon condition that the FCS calculation is successful in case the optional FCS is used, using TL-DATA indication;
- k) a BL-DATA PDU and then:
- i) the LLC shall delete the possible BL-ACK PDU from the sending buffer;
  - ii) the LLC shall:
    - if the FCS is used and it is correct or FCS is not used, then the LLC shall select a new handle to the request parameter value and deliver TL-SDU to the service user in a TL-DATA indication service primitive (handle to the request), memorize a waiting acknowledgement with number  $V(R) = N(S)$ , start to wait for TL-DATA response and inform the formatter by the DATA\_IN\_BUFFER signal;
- NOTE 1: As both MLE and LLC select handle to the request parameter values and both could select the same value a mechanism should be implemented to prevent it such as a sub-division of the value space.
- if the FCS is used and it is not correct and no other not yet acknowledged data received before the PDU with incorrect FCS was received, then no acknowledgement is sent, i.e. LLC action against the received BL-DATA with incorrect FCS is as that PDU was not received.
- l) a BL-ADATA PDU and then the LLC shall separate the acknowledgement  $N(R)$  and incoming TL-SDU including  $N(S)$  and shall continue as if LLC had received a BL-ACK PDU (without service user data) first (case j) and then a BL-DATA PDU (case k).

The LLC shall set the stealing permission parameter to "steal within time T.214" for the BL-ACK PDU in the basic link protocol in case the MAC currently has traffic transmit permission. The LLC should also set priority level = 5 (though this parameter will not normally be used by the MAC).

NOTE 2: At the reception of a new BL-DATA PDU before acknowledging the previous received BL-DATA PDU the LLC stops all acknowledgement actions of the previous TL-SDU independently of the TL-SDU number  $N(S)$ .

NOTE 3: The defined protocol and PDU numbering supports the receiving peer entity to request a TL-SDU re-sending, but it does not guarantee alone a safe mechanism for suppression of duplicate TL-SDUs.

NOTE 4: The transmission of a TL-SDU from a TL-DATA request primitive is totally independent of any data transmission in the other direction. On the other hand a TL-SDU from a TL-DATA response primitive is normally transferred in the corresponding acknowledgement of the TL-DATA indication primitive. If the TL-DATA response primitive is delayed too much, then the TL-SDU will be sent in a BL-DATA PDU and it will be acknowledged by a TL-DATA confirm primitive.

NOTE 5: The random access failure prevents further TL-SDU sending re-tries and to increase the probability to get an emergency message through the MAC will use more random access re-tries for higher priority TL-SDUs.

NOTE 6: The information "First complete transmission" by random access may be used in cancellation process in addition or in place of a request to the MAC.

### 22.3.2.4 Unacknowledged data transfer in the basic link

The procedures in an MS for unacknowledged data transfer in the basic link are described in the following clauses.

#### 22.3.2.4.1 Actions on TL-UNITDATA request (sending entity)

During sending of unacknowledged service user data the LLC may receive:

- a) a TL-UNITDATA request (handle to the request) from the service user and then:
  - the LLC may issue an immediate TL-REPORT indication containing the handle to the request parameter to the TL-UNITDATA request;
  - if requested by the service user, then the LLC shall calculate and append a FCS to the SDU;
  - the LLC shall store TL-SDU in priority order into the sending buffer for sending  $N.253 + 1$  times, and inform formatter with the DATA\_IN\_BUFFER signal.
- b) a MAC-READY from the formatter and then the LLC shall deliver the highest priority (unacknowledged service) TL-SDU as a BL-UDATA PDU to the formatter;
- c) a TMA-REPORT indication confirming the handle to the request parameter;
- d) a TMA-REPORT indication (successful complete transmission by random access), and then the LLC shall remove the TL-SDU from the transmitting buffer and deliver a TL-REPORT indication primitive (transfer completed) to the service user;
- e) a TMA-REPORT indication (complete transmission by stealing or by reserved access), and if that TL-SDU has now been completely transmitted  $N.253+1$  times, then the LLC shall remove the TL-SDU from the transmitting buffer and deliver a TL-REPORT indication primitive (transfer completed) to the service user;
- f) a TMA-REPORT indication (failure of fragmentation process) and then the LLC shall try to re-send the TL-SDU so that there shall be at maximum  $N.253+1$  failed transmissions in addition to the  $N.253+1$  complete transmissions. If there has not been  $N.253+1$  complete transmissions when the maximum number of failed transmissions  $N.253 + 1$  has been reached, then the LLC shall remove the TL-SDU from the sending buffer and issue a TL-REPORT indication primitive (failed transfer) to the service user;
- g) a TMA-REPORT indication (random access failure) and then the LLC shall remove TL-SDU from the sending buffer and issue a TL-REPORT indication (failed transfer) to the service user.

### 22.3.2.4.2 Actions on BL-UDATA PDU (receiving entity)

Upon reception of a BL-UDATA PDU from the formatter:

- i) if indicated by the received PDU, LLC shall calculate FCS and:
  - if the FCS is correct, the LLC shall inform the service user of a reception of a TL-SDU using a TL-UNITDATA indication;
  - If the FCS is not correct, the LLC shall discard the SDU.
- ii) if the received PDU does not contain FCS, then the LLC shall issue the TL-SDU to the service user using a TL-UNITDATA indication.

NOTE: The basic link protocol does not suppress received duplicates.

## 22.3.3 Advanced link procedures for the acknowledged service

The LLC advanced link protocol of the MS is modelled by processes: AL\_MAIN, AL\_TX, AL\_RX and Formatter, the latter being common also with the basic link and unacknowledged advanced link services, refer to figure 102. Refer to clause 22.3.1.7. for formatter processes.

The present document models the numbering of TL-SDUs and acknowledgements and local function indicators by local variables. Each advanced link shall employ separate sets of variables, parameters and timers.

At the sending entity:

- N(S) TL-SDU number in the sent data PDUs;
- N(R) TL-SDU number in the received acknowledgement PDUs;
- S(S) Segment number in the sent data PDU;
- S(R) Segment number in the received acknowledgement PDU.

At the receiving entity:

- N(S) TL-SDU number in the received data messages;
- N(R) TL-SDU number in the sent acknowledgement messages;
- S(S) Segment number in the received data PDU;
- S(R) Segment number in the sent acknowledgement PDU;

Timers and constants are defined in annex A.

In figure 102 the AL-MAIN controls independently the state of each advanced link.

Each advanced link set-up, data transfer, reconnection and disconnection phase is modelled by states:

- IDLE link is not ready for data transfer;
- WAIT\_IN\_CONNECT link is in the incoming set-up phase;
- WAIT\_OUT\_CONNECT link is in the outgoing set-up phase;
- WAIT\_DISCONNECT link is waiting for outgoing disconnection;
- WAIT\_RECONNECT link is waiting for reconnection;
- CONNECTED link is ready for data transfer.

The acknowledged information transfer in the CONNECTED state of each advanced link (N.261) is modelled by a single state in the sending process:

- AL\_TX\_READY transmitter is ready to send the next TL-SDU;

and respectively by a single state in the receiving process:

- AL\_RX\_READY receiver is ready to receive data from the MAC.

NOTE: It is recommended that the MS does not use fragmentation for sending advanced link PDUs.

### 22.3.3.1 Advanced link establishment for the acknowledged service

The service user shall set-up the advanced link before any data transmission may occur. The advanced link is available for data transfer until the service user or the LLC entity disconnects it. The advanced link number may be used locally as a part of the endpoint identifier related to an advanced link and its timeslot or timeslots used to send and receive the LLC PDUs. The established advanced link can be used for two-way information transfer.

There can be only one connection set-up in progress at the same time. If there are colliding set-ups from both peer entities, then those will be merged into a single set-up process.

The service user shall define the quality of service by setting up an advanced link and later by selecting that advanced link for the data transmission. The quality of service parameters applicable to the LLC layer are defined in clause 20. The set-up report parameter shall be used to indicate the progress of the connection establishment.

#### 22.3.3.1.1 Actions on TL-CONNECT request (set-up phase sending entity)

Upon reception of a TL-CONNECT request (handle to the request) in any state, the LLC:

- if the corresponding advanced link is already set-up, then the LLC shall cease both sending and reception actions, if needed cancel the relevant MAC layer SDU by a TMA-CANCEL request primitive, empty relevant data buffers and prepare an AL-SETUP PDU with a report "reset"; or  
if the corresponding advanced link is not already set-up, then the LLC shall prepare an AL-SETUP PDU with a report "service definition";
- set re-try counter to allow the maximum number of connection set-up retries N.262;
- inform formatter using DATA\_IN\_BUFFER signal and enter "WAIT\_OUT\_CONNECT" state.

NOTE: The LLC selects parameters for an AL-SETUP PDU according to the TL-CONNECT request parameters and current LLC capabilities e.g. available buffer sizes, see clause 20 for parameter definitions and clause 21 for PDU definitions. Suitable parameters for a AL-SETUP PDU depend on the quality negotiation between the service user and the DLL. The negotiation method is implementation dependent.

In the "WAIT\_OUT\_CONNECT" state the LLC may receive:

Local indication:

- a MAC-READY signal and then the LLC shall deliver the waiting AL-SETUP PDU, if any, to the formatter;
- a TMA-REPORT indication confirming the handle to the request;
- a TMA-REPORT indication (complete transmission) and if reason is "successful complete transmission by random access" or "complete transmission by reserved access or stealing", then the LLC shall start set-up waiting timer T.261;
- a TMA-REPORT indication (random access failure) and then the LLC shall inform a set-up failure to the service user by TL-REPORT indication primitive (set-up failure) and return into the "IDLE" state;
- set-up waiting time-out T.261 indication and:
  - if more retries (N.262) are available, then the LLC shall issue the previous AL-SETUP PDU into the transmission buffer and inform formatter by the DATA\_IN\_BUFFER signal;
  - if all retries (N.262) are used, then the LLC shall inform a set-up failure to the service user by TL-REPORT indication primitive (set-up failure) and return into the "IDLE" state;

PDU's from peer entity:

- f) an AL-SETUP PDU with the report "success" and then the LLC shall issue a TL-CONNECT confirm to the service user, stop set-up waiting timer T.261, prepare advanced link for data transfer in state "CONNECTED";
- g) an AL-SETUP PDU with report "service change" and then the LLC shall inform the service user by a TL-CONNECT indication. The service user shall respond with a TL-CONNECT response and the LLC shall act accordingly depending the value of "Set-up report" parameter (see clause 20.2.4.31) contained in the TL-CONNECT response primitive:
  - if the set-up report indicates that the parameters are acceptable, then the LLC shall prepare an AL-SETUP PDU with report "success" and inform formatter using DATA\_IN\_BUFFER signal. The LLC shall continue in the "WAIT\_IN\_CONNECT" state as defined in clause 22.3.3.1.2 e) to h);
  - if the set-up report indicates that the parameters are not acceptable, but there is a possibly suitable parameter set available, then the LLC shall prepare an AL-SETUP PDU with report "service change" and inform formatter using DATA\_IN\_BUFFER signal;
  - if the parameters are not acceptable and there is no suitable parameter set available, the connection establishment is rejected and then the LLC shall prepare an AL-DISC PDU with report "service not supported" and inform formatter using DATA\_IN\_BUFFER signal and deliver the AL-DISC PDU to the formatter as the response to the MAC-READY signal and then inform the service user by a TL-DISCONNECT indication "set-up failure" and return to the "IDLE" state.
- h) an AL-SETUP PDU with report "service definition" and then the LLC shall continue as described in clause 22.3.3.1.2 for the "IDLE" state;
- i) an AL-DISC PDU with report "service not supported", "service temporarily unavailable" or "reject" and then the LLC shall inform the service user by the corresponding TL-DISCONNECT indication and return to the "IDLE" state.

The MS may receive in the TMA-UNITDATA indication primitive carrying an AL-SETUP PDU the "Channel change response required" parameter set to "true", then the MS shall pass it in the corresponding TL-CONNECT primitive with the "Channel change handle" parameter to MLE.

### 22.3.3.1.2 Actions on AL-SETUP PDU reception (set-up phase receiving entity)

If the LLC is capable of supporting advanced link, then upon reception of an AL-SETUP PDU with one of the reports "service definition", "service change" or "reset" in the "IDLE" state, the LLC shall inform the service user by a TL-CONNECT indication with corresponding report and start to wait in state "WAIT\_IN\_CONNECT".

If the LLC does not for the moment support advanced link, then upon reception of an AL-SETUP PDU the LLC shall prepare an AL-DISC PDU with a report "service temporarily not available", inform formatter by DATA\_IN\_BUFFER signal and issue the AL-DISC PDU as a response to the next MAC-READY signal.

If the LLC does not at all support advanced link, then upon reception of an AL-SETUP PDU the LLC may prepare an AL-DISC PDU with a report "service not supported", inform formatter by DATA\_IN\_BUFFER signal and issue the AL-DISC PDU as a response to the next MAC-READY signal.

While waiting in state "WAIT\_IN\_CONNECT" the LLC may receive:

Service user initiated service primitives:

- a) a TL-CONNECT response primitive with the same parameters as in the TL-CONNECT indication and then the LLC shall prepare an AL-SETUP PDU with same parameters as in the received AL-SETUP PDU with a report "success" and inform the formatter by a DATA\_IN\_BUFFER signal;
- b) a TL-CONNECT response primitive with different parameters (less QoS) as in the TL-CONNECT indication and then the LLC shall prepare an AL-SETUP PDU with suitable parameters (QoS) and with a report "service change", inform the formatter by DATA\_IN\_BUFFER signal and continue in the "WAIT\_OUT\_CONNECT" state as defined in clause 22.3.3.1.1.
- c) a TL-CONNECT request primitive and then the LLC shall continue as if it had received that primitive from the service user as a sending entity, see clause 22.3.3.1.1;

- d) a TL-DISCONNECT request primitive and then the LLC shall prepare an AL-DISC PDU with a report "reject", inform formatter by DATA\_IN\_BUFFER signal and issue the AL-DISC PDU to the formatter as a response to the next MAC-READY signal and then return to the "IDLE" state.

Local indications due to the AL-SETUP PDU with the report "success" sending:

- e) a MAC-READY signal and then the LLC shall deliver the waiting AL-SETUP PDU to the formatter;
- f) a TMA-REPORT indication confirming the handle to the request;
- g) a TMA-REPORT indication (successful complete transmission by random access or complete transmission by reserved access or stealing) and then the LLC shall prepare advanced link for data transfer in state "CONNECTED";
- h) a TMA-REPORT indication (random access failure) and then the LLC may inform the service user by a TL-DISCONNECT indication primitive (set-up failure) and the LLC shall return into the "IDLE" state.

NOTE 1: The LLC entity should not normally receive an AL-SETUP PDU with a report "service change" or "reset" in the "IDLE" state, but if that happens, then the LLC should start normal connection establishment as if the received report were "service definition".

NOTE 2: The LLC entity should not normally receive an AL-SETUP PDU with a report "success" in states "IDLE" and "WAIT\_IN\_CONNECT", but if that happens, then the LLC should start normal connection establishment sending an AL-SETUP PDU with a report "service definition" as defined in clause 22.3.3.1.1.

NOTE 3: A TL-CONNECT response from the service user with a different set of parameters than in the corresponding TL-CONNECT indication primitive is taken as a new connect request and the LLC will respond to it with a TL-CONNECT confirm primitive before the data transfer may start.

The MS may receive in the TMA-UNITDATA indication primitive carrying an AL-SETUP PDU the "Channel change response required" parameter set to "true", then the LLC shall pass it in the corresponding TL-CONNECT primitive with the "Channel change handle" parameter to MLE.

### 22.3.3.1.3 Actions on AL-SETUP PDU reception (data transfer state)

Upon reception of an AL-SETUP PDU with a report "reset", "service definition" or "service change" in the "CONNECTED" state then:

- i) the LLC shall cease both sending and reception actions, empty relevant data buffers and, if needed, cancel any MAC layer sending by TMA-CANCEL request primitive; and
- ii) the LLC shall inform service user of the reset by a TL-CONNECT indication with the report "reset" and start to wait connection set-up progress in state "WAIT\_IN\_CONNECT" as defined in clause 22.3.3.1.2.

### 22.3.3.2 Acknowledged data transfer

In the advanced link, each data PDU in the acknowledged information transfer is identified by two numbers: a TL-SDU sequence number N(S) and a segment sequence number S(S). The TL-SDU sequence number is a three bit number incremented in a modulo manner with each transmitted TL-SDU. After the connection set-up or after a reset, the sending LLC entity shall start the TL-SDU numbering from "0". The segment sequence number is an absolute eight bit number indicating segments inside a TL-SDU. Those numbers are used in the segmentation and re-assembly processes and in the selective re-transmission process. The acknowledgement contains the corresponding TL-SDU sequence number N(R) and in the selective acknowledgement PDU a segment sequence number S(R). The acknowledgement cannot carry any layer 3 information.

The advanced link can be used for two-way information transfer.

#### 22.3.3.2.1 Segmentation and sequencing

The sending advanced link LLC entity shall segment a TL-SDU, if the size of it exceeds available MAC SDU size. Segments shall be sent in sequence. In order to allow a re-assembly in the selective re-transmission, the segments are numbered using a S(S) starting from "0" for each TL-SDU. The segment numbering is absolute, therefore a TL-SDU shall not comprise more than 256 segments.

The MAC sub-layer informs the next available segment size in the MAC-READY signal and the LLC should use the whole available size with possible exception of the last segment. The re-transmission of a segment shall not change the size of that segment, refer to clause 22.3.3.2.3.

The LLC shall use either AL-DATA or AL-DATA-AR PDU for a segment sending if the segment is not the last segment of a TL-SDU, and the LLC shall use either AL-FINAL or AL-FINAL-AR PDU if the segment is the last segment of a TL-SDU. The LLC shall use either AL-FINAL or AL-DATA PDUs if no acknowledgement is needed at this moment from the peer entity, and either AL-FINAL-AR or AL-DATA-AR PDU if acknowledgement is needed at this moment from the peer entity, refer to clause 22.3.3.2.3.

NOTE: The TL-SDU, as used in this definition, contains the FCS.

### 22.3.3.2.2 Re-assembly

Re-assembly is an operation opposite to segmentation. The receiving LLC entity shall re-assemble TL-SDU from the received segments. The advanced link protocol shall deliver received TL-SDUs to the service user in the TL-SDU sequence number order. At the reception of the first received segment (or every received segment) of a new SDU, the SwMI LLC entity sends a TL-RECEIVE indication to the service user indicating that data input is in progress.

### 22.3.3.2.3 Acknowledgement and segment re-transmission mechanisms

In this LLC protocol the sending entity is responsible of requesting acknowledgements from the receiving entity. The sending LLC may request an acknowledgement from the peer LLC and potentially cease data transmission by using either AL-DATA-AR or AL-FINAL-AR PDU. The sending LLC shall request an acknowledgement at latest, when it cannot continue sending due to the closing of TL-SDU window. The sending LLC should request an acknowledgement each time there is no more data for sending or there will be a pause in sending for other reasons. The LLC should minimize acknowledgement requests in good propagation situations.

In addition to the requested acknowledgements the receiver may choose to send acknowledgements at any time for its own purposes e.g. to clean up receiving buffers.

The receiving entity acknowledges both whole TL-SDUs and selectively segments of TL-SDUs by either AL-ACK or AL-RNR PDUs depending on the flow control needs, refer to clause 22.3.3.2.5. The sending entity shall re-transmit only the segments marked as bad in the last received AL-ACK or AL-RNR PDU. The re-transmission of segments shall start from the oldest segment in the oldest TL-SDU and continue until all segments for which a re-transmission is requested are transmitted. If the sending entity receives an acknowledgement for the whole TL-SDU, it informs the service user of the correct transfer of the layer 3 data by issuing a TL-DATA confirm. A segment shall keep its original sent segment number S(S), which indicates its absolute position inside the corresponding TL-SDU. The same sent TL-SDU number N(S) shall be used until all its segments have been successfully transmitted and the whole TL-SDU has been acknowledged (see clause 22.3.3.2.6) or TL-SDU transmission is failed or the advanced link is disconnected.

Upon reception of the acknowledgement request indicated by the AL-DATA-AR or AL-FINAL-AR PDU, the receiver entity shall send either the AL-ACK or the AL-RNR PDU, refer to clause 22.3.3.2.5. for flow control, with one or more acknowledgement blocks:

- i) the N(R) element shall indicate, which TL-SDU is acknowledged;
- ii) if the acknowledgement is for a whole TL-SDU, then the LLC shall set the acknowledgement length element to:
  - value 000000<sub>2</sub>, if the receiver accepts the TL-SDU;
  - value 111111<sub>2</sub>, if the receiver requests a re-sending of the TL-SDU; and
  - there shall be no other elements in that acknowledgement block.



- iii) if the receiver selectively acknowledges segments of the SDU then:
- the acknowledgement length element shall indicate the number of acknowledged segments; and
  - the S(R) element shall indicate the absolute position of the oldest not yet received segment in the TL-SDU; and
  - the bit map shall indicate the status of each segment starting from the next segment after the S(R) and moving forwards one segment at a time, up to the limit imposed by the last correctly received segment or by the available room in the AL-ACK or AL-RNR PDU; the status of the segment (STATUS) shall be set to "1" if it is correctly received and to "0" if it is not correctly received.

The receiving entity shall include an acknowledgement block for the TL-SDU corresponding to the AL-DATA-AR or AL-FINAL-AR. It should also include an acknowledgement block for any older TL-SDUs that are not yet completely received or that have not yet been acknowledged as completely received. It may include an acknowledgement block for newer TL-SDUs. If the acknowledgement blocks do not fit within one MAC block, then it may send multiple AL-ACK (or AL-RNR) PDUs.

If the data sending entity does not receive an acknowledgement message either AL-ACK or AL-RNR PDU within acknowledgement waiting time T.252, then:

- if the window size for TL-SDU N.272 is fully used, then the sending LLC shall repeat its acknowledgement request as above by using the oldest AL-DATA-AR or AL-FINAL-AR PDU as appropriate, for which there is no received acknowledgement; or
- if the SDU window size for TL-SDU N.272 is not fully used, then the sending LLC may continue its transmission by using AL-DATA(-AR) or AL-FINAL(-AR) PDU as appropriate.

NOTE: The sending entity may continue data transmission within TL-SDU window independently of the acknowledgement waiting timer.

#### 22.3.3.2.4 TL-SDU re-transmission

In the case all the segments of a TL-SDU have been received, but the FCS verification has failed, the whole TL-SDU shall be re-transmitted if within the allowed number of TL-SDU retransmissions N.273. The receiver shall indicate the FCS failure by setting value 11111<sub>2</sub> to the acknowledgement length information element in the AL-ACK or AL-RNR PDU. On the transmitter side, this TL-SDU shall be re-transmitted using the same TL-SDU discriminator and starting transmission from the first segment.

Refer to clause 22.3.3.2.6 for reasons of the sending entity to re-transmit a TL-SDU.

If the maximum number of TL-SDU re-transmission N.273 is exceeded, the sending LLC shall abandon the transmission of that TL-SDU and report an error to the service user using a TL-REPORT indication "failed transfer". The service user should stop to use the advanced link and either reset or disconnect it, refer to clauses 22.3.3.1.1 and 22.3.3.3 for protocol actions.

#### 22.3.3.2.5 Flow control

During the transmission in an advanced link, the receiving entity has the possibility to interrupt the transmitting entity from sending new TL-SDUs. The receiving entity shall use as acknowledgements either an AL-ACK or an AL-RNR PDU, if the receiver may continue to receive more data or is not capable of receiving more data respectively. The AL-RNR PDU shall also acknowledge already received PDUs and or segments of PDUs.

When an AL-ACK or AL-RNR PDU is sent over the air interface, it shall reflect the actual situation at the receiver at the transmission time of this acknowledgement.

Upon reception of an AL-RNR PDU the transmitting entity shall wait until either the peer entity sends an AL-ACK PDU or the receiver not ready validity timer for the sending entity T.271 expires (or until the link is disconnected or reset). The sender may continue sending of those TL-SDUs, which are partially acknowledged in the AL-RNR PDU or previously. The receiving entity may need to send more than one AL-RNR PDU, when there is more segments or PDUs waiting for positive or negative acknowledgement than fits into one AL-RNR PDU.

If the receiver not ready validity timer for sending entity T.271 expires, the sending entity shall try to start the sending of the TL-SDUs from the first unacknowledged PDU if there is still room in the TL-SDU sending window N.272, or from the last segment of the last already acknowledged TL-SDU, if there is no room in the TL-SDU window. If the receiving LLC cannot accept the new TL-SDU, it shall acknowledge the last already received and acknowledged TL-SDU by a AL-RNR PDU.

The receiving entity starts the receiver not ready validity timer T.272 when it sends an AL-RNR PDU over the air interface. If T.272 expires and the receiving entity is still incapable of receiving data, it may restart T.272 and send another AL-RNR PDU. T.272 is reset when the receiving entity sends an AL-ACK PDU over the air interface which indicates that the receiver is again capable of receiving data.

### 22.3.3.2.6 Actions on TL-DATA request (sending entity)

During acknowledged data transfer the LLC sending entity may receive (in state "AL\_TX\_READY") from the service user:

- a) a TL-DATA request primitive (handle to the request) and then:
  - i) the sending LLC may issue a TL-REPORT indication confirming the handle to the request parameter;
  - ii) the LLC shall calculate the FCS and append it to the TL-SDU;
  - iii) save the TL-SDU with the FCS into sending buffer and inform the MAC layer how much data is available for sending by the DATA\_IN\_BUFFER signal, see clause 22.3.1.7.2;

local indications:

- b) MAC-READY signal and then:
  - if there are no segments pending for re-transmission, the LLC shall format a new segment of the TL-SDU in the sending buffer as defined in clause 22.3.3.2.1 and issue it to the formatter and set the corresponding segment re-transmission counter;
  - if there is at least one segment pending for re-transmission and the maximum number of segment retransmissions N.274 of that segment is not exceeded, then the LLC shall select the oldest segment, for which there is a re-transmission request pending and issue the PDU to the formatter;
  - if there is at least one segment pending for re-transmission and the maximum number of the segment retransmissions N.274 of that segment is exceeded but the maximum number of TL-SDU retransmissions N.273 is not exceeded, then the LLC shall start re-sending of the complete TL-SDU and form a new starting segment of that TL-SDU and issue it to the formatter;
  - if there is at least one segment pending for re-transmission and both the maximum number of segment retransmissions N.274 of that segment and the maximum number of TL-SDU retransmissions N.273 are exceeded, then the LLC shall inform the service user about TL-SDU transmission failure by a TL-REPORT indication primitive (failed transfer);
- c) an indication, that the acknowledgement waiting timer T.252 has expired, refer to acknowledgement mechanisms in clause 22.3.3.2.3 for actions;
- d) a TMA-REPORT indication confirming the handle to the request;
- e) a TMA-REPORT indication (successful complete transmission by random access or complete transmission by reserved access or stealing) and if it is a response to either a AL-DATA-AR or AL-FINAL-AR PDU the LLC shall start acknowledgement waiting timer T.252;
- f) a TMA-REPORT indication (random access failure) and then the LLC shall inform the service user by a TL-REPORT indication primitive (failed transfer) and the LLC shall delete the TL-SDU from the sending buffer;

NOTE 1: After a failed transfer attempt (see b) and f) above) the service user should immediately either reset or disconnect the advanced link, which should be no more useable in the current state.

PDU from peer entity:

- g) an AL-ACK PDU either to acknowledge received segments and/or TL-SDUs or to indicate that the peer entity is capable to receive more data, refer to clause 22.3.3.2.3 for the actions on the acknowledgement;
- h) an AL-RNR PDU to acknowledge received TL-SDUs and/or segments and to indicate that the peer entity is currently not capable to receive more data, refer to flow control in clause 22.3.3.2.5.

NOTE 2: In this clause word segment is used instead of AL-DATA, AL-DATA-AR, AL-FINAL and AL-FINAL-AR PDUs, refer to segmentation in clause 22.3.3.2.1 and acknowledgement in clause 22.3.3.2.3 for selection of the correct PDU.

NOTE 3: The TL-SDU sending window is updated when the lowest SDU in the current window is completely acknowledged.

The MS may receive in the TMA-UNITDATA indication primitive carrying an AL-ACK or AL-RNR PDU the "Channel change response required" parameter set to "true", then the MS shall pass it in a TL-REPORT indication primitive with the "Channel change handle" parameter to MLE.

### 22.3.3.2.7 Data reception from the peer entity (receiving entity)

When advanced link LLC receiving entity is ready for receiving data (in the state "AL\_RX\_READY"), it may receive:

Local indications:

- a) MAC-READY signal and then the LLC shall send the AL-ACK or AL-RNR PDU as appropriate, see later in this clause and in clause 22.3.3.2.3 for the acknowledgement procedure;

PDU from the peer entity:

- b) AL-DATA or AL-FINAL PDU and then the LLC shall store segment into the correct position for reassembling in the corresponding TL-SDU and shall check completeness and correctness of the received TL-SDU; and
  - if the TL-SDU is completely and correctly received the LLC shall mark it received and ready for acknowledgement; and
  - if the number of the TL-SDU (N(S)) is the lowest SDU in the receiver window the LLC shall update both the lower and upper window boundary and deliver the received TL-SDU to the service user in a TL-DATA indication; or
  - if all segments of that TL-SDU are received, but the FCS calculation fails, then the LLC shall discard that SDU and mark that it needs to be re-transmitted.
- c) AL-DATA-AR or AL-FINAL-AR PDU and then the LLC shall store segment into the correct position for reassembling in the corresponding TL-SDU and shall check completeness and correctness of the received TL-SDU; and
  - if at least one new TL-SDU is completely and correctly received (FCS matches) the LLC shall mark it received and prepare either AL-ACK or AL-RNR PDU as defined in clause 22.3.3.2.5 with a possible bitmap of the unacknowledged segments in the other SDUs, inform the formatter by the DATA\_IN\_BUFFER signal and if the number of the TL-SDU (N(S)) is the lowest SDU in the receiver window the LLC shall update the lower window boundary and deliver the received TL-SDU to the service user in a TL-DATA indication;

NOTE 1: In case the SwMI LLC entity receives an AL-DATA(-AR) or AL-FINAL(-AR) PDU with a new TL-SDU number N(S), the SwMI LLC should indicate to the LLC service user that the reception of new TL-SDU has started by a TL-RECEIVE indication primitive.

- if all segments of that TL-SDU are received, but the FCS calculation fails, then the LLC shall discard that PDU and prepare either AL-ACK or AL-RNR PDU asking re-transmission of that TL-SDU, with a possible bitmap of the unacknowledged segments in the other SDUs and inform the formatter by the DATA\_IN\_BUFFER signal;

- if no TL-SDU is received correctly, then the LLC shall mark the segment received and prepare either AL-ACK or AL-RNR PDU, with a bitmap of the unacknowledged segments in this and possibly other SDUs and inform the formatter by the DATA\_IN\_BUFFER signal;

The LLC shall use priority level = 5 and allow frame stealing for a response to an AL-DATA-AR or AL-FINAL-AR PDU (though in most cases neither of these parameters will actually be used in the MAC, since AL-ACK and AL-RNR are usually sent by reserved access).

indication from the service user:

- d) a FLOW-NOT-READY signal and then the LLC shall prepare an AL-RNR PDU, with a possible bitmap of the unacknowledged segments in the received SDUs and inform the formatter by the DATA\_IN\_BUFFER signal;
- e) a FLOW-READY signal and then the LLC shall prepare an AL-ACK PDU, with a possible bitmap of the unacknowledged segments in the received SDUs and inform the formatter by the DATA\_IN\_BUFFER signal, refer to flow control in clause 22.3.3.2.5.

NOTE 2: The receiving process delivers TL-SDUs in the sequence defined by the N(S).

NOTE 3: If it receives any of the data transfer PDUs (AL-DATA, AL-DATA-AR, AL-FINAL or AL-FINAL-AR), when the corresponding advanced link is no more in "RX\_READY" state, then the PDU will be discarded in this model by the formatter without any further actions.

NOTE 4: When the LLC receiving entity has completely and correctly received a TL-SDU, and if the number of the TL-SDU is the lowest in the receiver window, then the LLC updates the lower window boundary and delivers the received TL-SDU to the service user. However, even when the LLC has sent an acknowledgement for the correctly received TL-SDU, that acknowledgement may not have been received by the sending entity. Therefore the LLC may still receive AL-DATA(-AR) and AL-FINAL(-AR) PDUs for the N.272 TL-SDUs below the current receiver window. If this occurs, the receiving LLC should discard the received segment(s) but should send an acknowledgement to indicate that the TL-SDU has been correctly received.

NOTE 5: In the LLC advanced link protocol the sending entity should retry transmission in case it does not receive an expected acknowledgement since the protocol actions taken in case of a transmission failure of an AL-ACK or AL-RNR PDU are not defined in the present document.

The MS may receive in the TMA-UNITDATA indication primitive carrying an AL-DATA(-AR) and AL-FINAL(-AR) PDU the "Channel change response required" parameter set to "true", then the MS shall pass it in a TL-REPORT indication or if available in the corresponding TL-DATA indication primitive with the "Channel change handle" parameter to MLE.

### 22.3.3.3 Release of acknowledged service advanced link

In the advanced link the end of the transfer shall be notified by AL-DISC PDU with reason "close". In the acknowledged data transfer the disconnection shall be confirmed by sending a AL-DISC PDU with reason "success". Disconnection may occur at any time. When the receiving entity recognizes a disconnect it shall delete all partially received TL-SDUs.

#### 22.3.3.3.1 Actions on TL-DISCONNECT request (MS sending entity)

Upon reception of a TL-DISCONNECT request in state WAIT\_OUT\_CONNECT or CONNECTED, the LLC shall:

- i) prepare an AL-DISC PDU with reason "Close" and inform the formatter by DATA\_IN\_BUFFER signal;
- ii) set re-try counter to allow the maximum number of connection disconnect retries N.263;
- iii) cease all sending and receiving any data and discard all TL-SDUs waiting for sending or which are partially received on this advanced link and start to wait in "WAIT\_DISCONNECT" state.

In the "WAIT\_DISCONNECT" state the LLC may receive:

Local indications:

- a) a MAC-READY signal and then the LLC shall issue the AL-DISC PDU to the formatter;
- b) a TMA-REPORT indication (successful complete transmission by random access or complete transmission by reserved access or by stealing) and then the LLC shall start the disconnection waiting timer T.263;
- c) a TMA-REPORT indication (random access failure) and then the LLC shall inform the service user by a TL-DISCONNECT confirm (random access failure) and go into the "IDLE" state;
- d) an indication of the expiry of the disconnection waiting timer T.263 and:
  - if more retries (N.263) are available, then the LLC shall issue the previous AL-DISC PDU into the transmission buffer and inform formatter by the DATA\_IN\_BUFFER signal;
  - if all retries (N.263) are used, then the LLC shall inform the service user by a TL-DISCONNECT confirm (disconnection failure) and go into the "IDLE" state.

A PDU from the peer entity:

- e) an AL-DISC PDU with reason "Success", then the LLC shall inform the service user by a TL-DISCONNECT confirm and go into "IDLE" state;
- f) an AL-DISC PDU with reason "Close", then the LLC shall deliver an AL-DISC PDU with reason "Success" to the formatter as a response to the next MAC-READY signal and go into "IDLE" state.

#### 22.3.3.3.2 Actions on AL-DISC PDU reception (MS receiving entity)

While being ready for data transfer the advanced link LLC may receive:

A PDU from the peer entity:

- a) an AL-DISC PDU with reason "Close" and then:
  - i) the LLC shall stop sending and receiving any data and discard both TL-SDUs waiting for sending and TL-SDUs, which are partially received or fully received;
  - ii) prepare an AL-DISC PDU with a reason "Success" and inform the formatter by the DATA\_IN\_BUFFER signal;
  - iii) indicate to the service user the removal of the advanced link using a TL-DISCONNECT indication primitive "incoming disconnection";

Local indications after preparing an AL-DISC PDU:

- b) a MAC-READY signal and then the LLC shall issue the AL-DISC PDU to the formatter;
- c) a TMA-REPORT indication (successful complete transmission by random access or complete transmission by reserved access or by stealing) and then the LLC shall go into "IDLE" state;
- d) a TMA-REPORT indication (random access failure) and then the LLC shall go into the "IDLE" state.

When the LLC receives in the "IDLE" state an AL-DISC PDU with reason "Close", the LLC shall deliver an AL-DISC PDU with reason "Success" to the formatter as a response to the next MAC-READY signal.

NOTE: An MS may receive an AL-DISC PDU also in other states of the LLC protocol, refer to advanced link establishment actions.

#### 22.3.3.4 Abnormal release of advanced link

While in any state the advanced link LLC may receive:

- a) a TL-RELEASE request primitive from the service user and then the LLC shall close the advanced link without any signalling with the peer entity and go to "IDLE" state;

- b) a TMA-RELEASE indication primitive and then the LLC shall close the advanced link without any signalling with the peer entity, indicate link disconnection to the service user by a TL-DISCONNECT indication with a reason "local disconnection" and go to "IDLE" state.

### 22.3.3.5 Reconnection of acknowledged service advanced link

A request to reconnect an advanced link shall be notified using the AL-RECONNECT PDU with a reconnect report "propose". A successful reconnection of the advanced link shall be confirmed by the reception of an AL-RECONNECT PDU with the reconnect report "accept" and unsuccessful reconnection by the reception of an AL-RECONNECT PDU with the reconnect report "reject".

Upon reception of a TL-RECONNECT request primitive in state "CONNECTED", the LLC shall:

- i) prepare an AL-RECONNECT PDU with reason "propose" and inform the formatter by DATA\_IN\_BUFFER signal;
- ii) set re-try counter to allow the maximum number of reconnect retries N.265;
- iii) cease all sending and receiving any data and start to wait in "WAIT\_RECONNECT" state.

In the "WAIT\_RECONNECT" state the LLC may receive:

Local indications:

- a) a MAC-READY signal and then the LLC shall issue the AL-RECONNECT PDU to the formatter;
- b) a TMA-REPORT indication (successful complete transmission by random access or complete transmission by reserved access or by stealing) and then the LLC shall start the reconnection waiting timer T.265;
- c) a TMA-REPORT indication (random access failure) and then the LLC shall inform the service user by a TL-RECONNECT confirm with the reconnection result set to "random access failure";
- d) an indication of the expiry of the reconnection waiting timer T.265 and:
  - if more retries (N.265) are available, then the LLC shall issue the previous AL-RECONNECT PDU into the transmission buffer and inform formatter by the DATA\_IN\_BUFFER signal;
  - if all retries (N.265) are used, then the LLC shall inform the service user by a TL-RECONNECT confirm with the reconnection result set to "reconnection failure".

A PDU from the peer entity:

- e) an AL-RECONNECT PDU with reason "accept", then the LLC shall inform the service user by a TL-RECONNECT confirm with the reconnection result set to "success" and go into "CONNECTED" state, accept the channel change, if any, by issuing a TMC-CONFIGURE request to MAC with the parameter channel change accepted set to "accept" and continue to transmit and receive TL-SDU segments without resetting the advanced link;
- f) an AL-RECONNECT PDU with reason "reject", then the LLC shall inform the service user by a TL-RECONNECT confirm with the reconnection result set to "reject" and accept the channel change, if any, by issuing a TMC-CONFIGURE request to MAC with the parameter channel change accepted set to "accept".

## 22.3.4 Advanced link procedures for unacknowledged service

The unacknowledged service uses the same mechanisms for sequencing, segmentation and re-assembling as the acknowledged service (see clauses 22.3.3.2.1 and 22.3.3.2.2). The window size for TL-SDU in unacknowledged service N.281 defines how many TL-SDUs may be in transit at the same time. The numbering of TL-SDUs N(S), contrary to the acknowledged service, may start at any value.

### 22.3.4.1 Advanced link unacknowledged service establishment

The BS should established the unacknowledged service before it starts to send data.

The BS should start unacknowledged data transfer by sending one or more AL-SETUP PDUs. During unacknowledged data transfer the BS may repeat the AL-SETUP PDU using current value for the TL-SDU number N(S) to re-synchronize receiving MSs. The TL-SDU numbering may start at any value to allow re-setting of an unacknowledged service without re-setting the TL-SDU window position. After the reception of a AL-SETUP PDU the TL-SDU window lower edge shall be the TL-SDU number N(S) and the upper edge shall be  $N(S) + N.281 - 1$  (Window size for TL-SDU in unacknowledged service). After sending an AL-SETUP PDU the BS should not repeat any TL-SDU or segments of those having a TL-SDU sequence number lower than the one (N(S)) indicated in the AL-SETUP PDU.

#### 22.3.4.2 Reception of unacknowledged service data

The LLC MS entity may receive at any state:

- a) an AL-SETUP PDU for unacknowledged information reception and then the LLC shall deliver an TL-CONNECT indication to the service user and shall empty possible current buffer, prepare a new buffer for data reception, inform the service user by a TL-CONNECT indication (unacknowledged service) and start to wait for data in the state "AL\_UNACK\_READY";
- b) an AL-DISC PDU and then the LLC shall discard all partially received TL-SDUs and may deliver an TL-DISCONNECT indication to the service user.

While in the "AL\_UNACK\_READY" state the MS LLC may receive an AL-UDATA PDU or an AL-UFINAL PDU; and:

- if the corresponding TL-SDU is not earlier delivered to the service user, then the LLC shall store the segment into correct position of the relevant TL-SDU as indicated by N(S) and S(S) elements respectively; and
- if a TL-SDU is now completely and correctly received, then the LLC shall deliver the TL-SDU to the service user in a TL-UNITDATA indication primitive and mark the TL-SDU as received.

NOTE 1: The MS LLC may deliver the received TL-SDUs out of sequence.

NOTE 2: The advanced link protocol allows suppression of received duplicates.

Each time the LLC receives an AL-UDATA or an AL-UFINAL PDU the LLC shall upgrade the receiving window upper edge to the received N(S) if it is higher than the current upper edge and calculate a new lower edge. The LLC shall then check if there are any partially received TL-SDUs, which have TL-SDU number outside the new receiving window and then the LLC shall discard those partially received SDUs.

NOTE 3: An AL-SETUP PDU for unacknowledged information reception (or an AL-UDATA or AL-UFINAL PDU) may be sent in a group addressed MAC PDU that contains a channel allocation. If the MS-MAC requires instruction on whether to accept the channel allocation, then it sets the "channel change response required" parameter to "true" in the TMA-UNITDATA indication primitive. If the MS decides to accept the channel allocation then the higher layers should issue a TMC-CONFIGURE request primitive to the MAC containing the "channel change handle" parameter and "channel change accepted" parameter set to "accept". However, if a channel change is not acceptable, a TMC-CONFIGURE request primitive should be issued with the "channel change parameter" set to "reject".

#### 22.3.4.3 Sliding SDU window in unacknowledged service

The BS LLC should send unacknowledged data using a TL-SDU window size of 1 to the maximum N.281. This means that the BS LLC may transmit with all repetitions up to N.281 different TL-SDUs at any time. When all repetitions of the lowest numbers TL-SDU are completed, then the BS LLC may start to send a new TL-SDU. The BS LLC informs the TL-SDU window size at the establishment of the advanced link by sending one or more AL-SETUP PDUs.

#### 22.3.4.4 Disconnection of unacknowledged data transfer

The BS may disconnect an unacknowledged service by sending one or more AL-DISC PDUs. When the MS receives an AL-DISC PDU it shall discard all partially received TL-SDUs and cease reception of all AL-UDATA PDUs.

### 22.3.5 Channel change request handling

MAC layer may issue with TMA-UNITDATA indication "channel change response required" parameter with value "true" indicating that an upper layer shall provide a response to MAC layer.

Upon reception of a "channel change response required" in a TMA-UNITDATA indication:

- if the TMA-UNITDATA indication contains a TL-SDU the LLC shall pass the request to MLE in the corresponding TL-UNITDATA indication;
- if the TMA-UNITDATA indication contains no TL-SDU LLC and the endpoint identifier refers to an advanced link service MAC resource the LLC may pass the request to MLE in a TL-REPORT indication or decide to accept or reject the request based on the other LLC services and their importance;

NOTE 1: The same endpoint identifier refers to the advanced link and to the related basic link when advanced link exists.

NOTE 2: The service importance determination at the LLC is outside the scope of the present document.

- if the TMA-UNITDATA indication contains no TM-SDU LLC and the endpoint identifier refers only to the basic link service MAC resource and there is only a single user of LLC services the LLC shall pass the request to MLE in a TL-REPORT indication;

NOTE 3: How LLC knows the number of service users is outside the scope of the present document.

- in other cases the actions are outside the scope of the present document.

MAC layer may issue TMC-CONFIGURE indication due to various resource conflicts. Upon reception of a TMC-CONFIGURE indication with reason "loss of physical resources":

- if the indication is related to an advanced link and the MS supports advanced link reconnection and there is one or more uncompleted TL-SDU in the send or reception buffer the LLC shall indicate to the MLE in a TL-CONFIGURE indication the loss of physical resources for that endpoint identifier and retain the advanced link for a potential reconnection without sending any new TM-UNITDATA requests for that advanced link;

NOTE 4: Only SNDCP layer can support advanced link reconnection, refer to clause 29, and any upper layers may disconnect locally the advanced link by a TL-RELEASE request.

- if the indication is related to an advanced link and the MS does not support advanced link reconnection or MS supports advanced link reconnection but there is no uncompleted TL-SDU in the send or reception buffer the LLC shall indicate to the MLE in a TL-CONFIGURE indication the loss of physical resources for that endpoint identifier and locally disconnect the advanced link;
- if the indication is related to a basic link the LLC shall indicate to the MLE in a TL-CONFIGURE indication the loss of physical resources for that endpoint identifier.

Upon reception of a TMC-CONFIGURE indication with reason "gain of physical resources" the LLC may continue to use the indicated MAC resource.

NOTE 5: Before LLC can use the resource for a retained advanced link the link is first reconnected by upper layer actions, refer to clause 28.

MAC layers may also issue a TMA-RELEASE indication due to loss of radio resources, when the loss is detected locally without a signalling from BS. The LLC behaviour is defined in clause 22.3.3.4.

---

## 23 MAC protocol

This clause describes the V+D air interface layer 2 MAC protocol. It defines the operation of the MAC layer in the MS and includes some corresponding rules for the operation of the BS. However, the exact rules for how the BS allocates resources to MSs are outside the scope of the present document.

See EN 300 392-1 [9], clause 6 for the general architecture and a description of all layers including the functionality of the MAC sub-layer (see clause 19 for the architecture of the DLL). MAC timers and constants are defined in annex B.



## 23.1 MAC services

### 23.1.1 Functions of MAC

In the protocol model, internal communication between the LLC and the MAC uses three SAPs TMA-SAP, TMB-SAP and TMC-SAP, corresponding to signalling, broadcast and layer management functions respectively. A fourth SAP, the TMD-SAP, supports traffic in circuit mode; this service is offered directly from the MAC to the U-plane application (e.g. the CODEC).

The MAC itself is divided into two sub-layers, i.e. the upper and lower MAC.

The lower MAC performs the channel coding, interleaving and scrambling, as described in clause 8. The upper MAC performs the other MAC protocol functions and is described in this clause. Unless specified otherwise, references to "the MAC" in this clause mean the upper MAC.

The principal functions of the upper MAC are as follows:

- frame and multiframe synchronization;
- multiplexing/de-multiplexing of the logical channels;
- radio path establishment and channel allocation (for common control channels and for assigned channels);
- address management for the layer 2 address (the source address for the uplink, the destination address for the downlink);
- fragmentation of long messages received from the LLC (subdividing the LLC message between more than one MAC block);
- association of short messages received from the LLC (enabling more than one message to be sent within one MAC block);
- management of power control;
- the random access procedure (contention control);
- granting and use of reserved slots i.e. non-contentious slots reserved by the BS for one MS to send signalling message(s);
- path loss calculation: surveillance of the serving cell, and monitoring and scanning of adjacent cells;
- energy economy operation;
- providing service to circuit mode applications (e.g. speech CODEC or circuit mode data);
- stealing from the traffic channel capacity, when required, to send signalling messages.

### 23.1.2 Service primitives

The MAC protocol is described in terms of primitives and valid sequences of actions resulting from those primitives. Refer to clause 20 for a detailed description of the service primitives.

The use of primitives in this clause refers to the protocol definition, but does not imply any specific implementation. The MAC boundary, as for other internal boundaries, is defined to clarify the protocol description. The word "shall" is used to describe the SAPs and primitives for traceability reasons in the protocol model, but those SAPs and primitives are not testable.

### 23.1.2.1 Services at the TMA-SAP

The TMA-SAP shall be used for the transmission of signalling and packet data information over the air interface. Service data units, TM-SDUs, shall be transferred to and from the LLC using the TMA-UNITDATA primitive. (The TM-SDU is the LLC PDU, including the LLC header and optional FCS.)

- The TMA-UNITDATA request from LLC to MAC shall be used when the LLC wishes to send data to the peer entity;
- The TMA-UNITDATA indication from MAC to LLC shall be used to deliver data received from the peer entity.

The MAC in the MS (MS-MAC) shall report the progress of a request procedure locally to the LLC using the TMA-REPORT indication primitive. The LLC may abort a TMA-UNITDATA request using the TMA-CANCEL request primitive.

The random access protocol is generally needed when the MS sends a message to initiate a call or transaction. However, when an MS is required to send a solicited message or when it has further signalling to send after the initial access, the BS may reserve slots for that particular MS. This enables a higher channel throughput to be achieved.

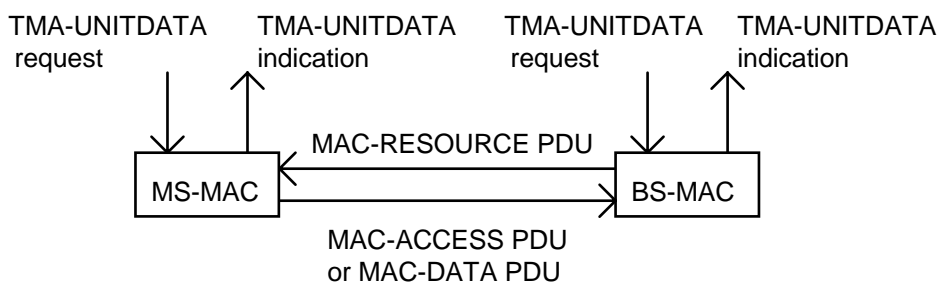
On a control channel, MSs may transmit only by random access or reserved access. Whereas, during a circuit mode call, the transmitting MS may "steal" from the traffic channel capacity to send signalling messages.

The signalling service offered by the MS-MAC to the LLC shall be an unacknowledged service in the case of non-contentious transmission (i.e. reserved access or stealing). The MAC receives a TM-SDU from the LLC, transmits the TM-SDU (in one or more MAC blocks) and then reports to the LLC when the message has been sent. Acknowledgements and retransmissions are under the control of the LLC.

However, for contentious access (i.e. random access), the MS-MAC is responsible for sending retries until it receives a MAC response from the BS indicating successful random access. The report to the LLC shall then indicate that the BS has acknowledged the random access message.

TMA-SAP signalling messages may generally be sent using the MAC-RESOURCE PDU for the downlink, or the MAC-ACCESS PDU (in a subslot) or MAC-DATA PDU (in a full slot) for the uplink. A general scenario for an exchange of two LLC messages is shown in figure 138. (Other PDUs, MAC-FRAG and MAC-END(-HU), shall be used for continuations and end of a fragmented TM-SDU.)

The uplink MAC-ACCESS and MAC-DATA PDUs shall include the layer 2 address and usually carry a TM-SDU; they can also be used to request reserved slots for signalling messages. On the downlink, the MAC-RESOURCE PDU usually includes layer 2 addressing and may contain a TM-SDU. The MAC-RESOURCE PDU may also include elements for granting reserved slots and/or for channel allocation and/or for power control. The MAC PDUs are defined in clause 21.



**Figure 138: Scenario for exchange of two LLC messages**

#### 23.1.2.1.1 Reports

When the MS-MAC receives a TMA-UNITDATA request primitive from the LLC, the primitive includes a local identifier for the service request, referred to as the "handle to the request". The handle should be retained locally and used for routing subsequent reports (TMA-REPORT indication primitive). It refers to all actions required in the MAC to accomplish the request.

The MS-MAC shall issue reports to the LLC at the following times:

- i) first transmission of complete TM-SDU by random access;
- ii) when the BS acknowledges reception of a complete TM-SDU sent by random access;
- iii) complete TM-SDU (or final fragment of a fragmented TM-SDU) has been sent by reserved access or by stealing;
- iv) random access failure;
- v) failure of fragmentation process (TM-SDU not completely sent).

Also, in the case of a TMA-CANCEL request, the MS-MAC shall report whether or not the TM-SDU has been completely sent.

After sending reports ii), iii), iv), v), or after cancellation, the MS-MAC shall regard the requested procedure as complete. The MS-MAC shall discard the TM-SDU and the handle becomes invalid.

#### 23.1.2.1.2 Buffering mechanism

When the MS-MAC receives a downlink PDU addressed to that MS, it shall immediately deliver any TM-SDU to the LLC using the TMA-UNITDATA indication (except in the case of a fragmented message, when the MS-MAC shall reconstruct the entire TM-SDU before delivering it to the LLC).

For an MS sending PDUs, there may be many messages to be sent. For the purposes of the protocol description, it is assumed that the layer 2 queue of messages is held in the LLC and that the MAC has a sending buffer only.

According to this protocol description, there shall be two related signals between MS-MAC and MS-LLC.

- i) DATA-IN-BUFFER signal from LLC to MAC.

This shall indicate the total amount of outstanding signalling data that the LLC has ready to send for a particular address on the channel corresponding to the specified endpoint identifier, and not yet given to the MAC.

It shall also indicate the maximum values of the PDU priority and stealing permission parameter for the messages in the LLC queue for that address and channel. These parameters enable the MAC to decide on the appropriate means to transfer the information before receiving the actual service request.

- ii) MAC-READY signal from MAC to LLC.

This signal shall be issued to the LLC when the MS-MAC is ready to send a MAC block.

It shall indicate the maximum size of TM-SDU that can be carried within the MAC PDU that the MS-MAC intends to send, i.e. the maximum size without requiring fragmentation.

It shall also indicate the absolute maximum size of TM-SDU that can be handled in the MAC at this time. This is normally the maximum size of fragmented TM-SDU (up to N.202 bits), but shall be reduced in the case of stealing to either the size of the MAC block or to the capacity of two half slots if two-half-slot stealing is appropriate at this time.

On receipt of the MAC-READY signal, the LLC will usually issue a TMA-UNITDATA request primitive to the MAC (see also clause 22).

NOTE: The ISSI and its associated ASSI are equivalent for the purposes of the buffering mechanism, so the MS may use the same signal for the ISSI and ASSI.

#### 23.1.2.1.3 Usage of signals

This clause describes the usage of the MAC-READY and DATA-IN-BUFFER signals. The actual MAC procedures for fragmentation, association, random access, reserved access and stealing are described later in this clause. The procedures a), b) and c) below relate to the protocol model of the interface with the LLC and do not imply any specific implementation.

### a) Random access

If the DATA-IN-BUFFER signal from the LLC indicates that there is data to send, and if the MS-MAC has neither been granted any reserved slots nor asked for reserved slots for that address on that channel, then the MS-MAC should prepare to initiate the random access procedure. The MS-MAC shall issue the MAC-READY signal to the LLC, indicating the available size of TM-SDU within the MAC-ACCESS PDU.

- i) If the LLC issues a TMA-UNITDATA request primitive containing a TM-SDU that fits within the MAC block then the MAC-ACCESS PDU shall carry that TM-SDU. If there is still space within the MAC block for another PDU by association, the MS-MAC may repeat the MAC-READY/TMA-UNITDATA exchange process as required until there is not space for another MAC header.
- ii) If the LLC issues a TMA-UNITDATA request primitive containing a TM-SDU that does not fit within the MAC-ACCESS PDU then the MAC-ACCESS PDU shall carry a first fragment of the TM-SDU, using the fragmentation procedure and including a request for reserved capacity within the MAC-ACCESS PDU.
- iii) If the LLC does not issue a TMA-UNITDATA request primitive then the MAC-ACCESS PDU shall contain a request for reserved capacity but shall not carry a TM-SDU. This case may arise if the LLC has only full-slot advanced link messages to send at this time.

NOTE 1: The maximum available size of TM-SDU in the MAC-ACCESS PDU is variable, depending on whether the MS requests reserved capacity for further signalling.

### b) Reserved access

When the MS-MAC has a reserved slot (or subslot) individually granted to it by the BS then, if it is already in the process of sending a fragmented TM-SDU, it shall send the next fragment. Or, if there is no data in the LLC buffer for that address and channel, the MS-MAC shall send the Null PDU. Otherwise, just before the transmission is due, the MS-MAC shall issue the MAC-READY signal to the LLC, announcing the maximum available size of TM-SDU in this MAC-DATA (or MAC-ACCESS) PDU.

Then procedures i), ii) and iii) above generally apply except that the appropriate PDU for a full slot is MAC-DATA, and case iii) should not occur for the first PDU in a reserved full slot.

NOTE 2: The timing of the MAC-READY signal should be as late as possible, to allow the maximum time if the layer 3 in the MS is preparing a response to a BS message.

### c) Stealing

When the MS is transmitting in a circuit mode call, and if there is data in the LLC buffer for that channel for which the stealing permission parameter indicates that stealing may be used, then the MS-MAC shall issue the MAC-READY signal to the LLC indicating:

- the size of TM-SDU in this MAC block; and
- the maximum valid size of TM-SDU, given any current stealing limitations.

The fragmentation and association mechanisms may apply as described above. If the LLC does not issue a TMA-UNITDATA request primitive, for example because the message is too long, then the MS-MAC shall not perform the stealing but may use the TMA-SAP procedures (i.e. random access and/or reserved access) to send the messages in the LLC buffer.

#### 23.1.2.1.4 Priority and subscriber class

The TMA-UNITDATA request primitive includes the layer 2 priority of the message, the stealing permission parameter and the subscriber class parameter. And the DATA-IN-BUFFER signal indicates the maximum priority and stealing permission parameter in the LLC queue. The MS-MAC shall use these parameters as follows:

- i) The MS-MAC may need to use the priority and subscriber class parameter from the TMA-UNITDATA request in the random access procedure, if the BS has announced priority or subscriber class restrictions on random access at this time.
- ii) The priority from the DATA-IN-BUFFER signal may also be used to cut short the reserved access waiting time-out if there is an emergency message in the LLC buffer, so that the MS may initiate the random access procedure.
- iii) The stealing permission parameter may be used to trigger the stealing mechanism.

There are eight possible levels of the layer 2 PDU priority, from the lowest priority 0, increasing to the highest priority 7 corresponding to an emergency message.

There are 16 possible subscriber classes, allowing a population subdivision, e.g. for random access control. The operator defines the values and meaning of each class, and the MS may belong to one or more of those classes. The subscriber class parameter, as supplied in primitives from the higher layers, is a bit mapped field which indicates, for each class, whether the MS belongs to that class.

The stealing permission parameter defines whether the MAC may use stealing to send this message, if the MS is currently transmitting traffic. It may have the following meanings:

- stealing not required;
- steal when convenient;
- steal within time T.214; or
- steal immediately.

NOTE: If the MS is not transmitting traffic, the MAC ignores the stealing permission parameter.

#### 23.1.2.2 Services at the TMB-SAP

The TMB-SAP shall be used for the transfer of un-addressed system broadcast messages. The primitives shall be TMB-SYNC and TMB-SYSINFO. The request primitive shall be used in the BS. The indication primitive shall be used in the MS to deliver the TM-SDU to the higher layers.

The corresponding PDUs shall be the SYNC and SYSINFO PDU, the content of BSCH and BNCH respectively. Both PDUs contain many MAC elements, and also include a TM-SDU used by the MLE.

#### 23.1.2.3 Services at the TMC-SAP

The TMC-SAP shall be used for the transfer of local layer management information. It provides no data transfer services over the air interface. It shall be used, for example, for the higher layers to instruct the MAC to reconfigure its parameters, for the MLE to direct monitoring and scanning procedures in the MAC and for the MAC to issue reports on progress.

#### 23.1.2.4 Services at the TMD-SAP

The TMD-SAP shall provide the interface between the MAC and the circuit mode U-plane application, e.g. the speech CODEC. It shall be used for the transfer of speech frames or circuit mode data. It shall also be used if the U-plane application steals from the traffic capacity to send encryption synchronization information and/or user-to-user signalling messages.

The TMD-UNITDATA request primitive from the U-plane application to the MAC shall be used when the U-plane application wishes to send data to the peer entity.

The TMD-UNITDATA indication primitive from the MAC to the U-plane application shall be used to deliver data from the peer entity.

There is also a TMD-REPORT indication, which shall be used by the MAC to issue reports to the U-plane application e.g. when the MAC has stolen capacity from the traffic channel.

### 23.1.2.5 Use of endpoint identifiers

The MS-MAC receives a common control channel, i.e. the MCCH or a common SCCH, unless directed by the BS to an assigned channel - assigned for a circuit mode call or for secondary control (see clause 23.3). A common control channel comprises one timeslot per TDMA frame whereas an assigned channel comprises one or more timeslots per TDMA frame. It is optional for an MS to be capable of using a multi-slot channel.

The MS may be capable of processing only one channel at a time, either a common control channel or an assigned channel.

Other MSs may be capable of processing more than one channel simultaneously, allowing concurrent MAC services to be provided. The "endpoint identifier" is a local identifier used to distinguish between multiple concurrent service instances.

At the LLC-MAC boundary, the endpoint identifier shall refer to the use of a particular MAC channel, i.e. common control channel or assigned channel. It identifies the MAC channel to which a particular TMA-UNITDATA or TMD-UNITDATA primitive (or DATA-IN-BUFFER or MAC-READY signal) applies. There shall be a unique correspondence between the endpoint identifier and the physical channel allocation used in the MAC (i.e. the timeslot for a single-slot channel or timeslots for a multi-slot channel).

NOTE 1: This correspondence is known only within the MAC. The endpoint identifier is used by the higher layers as a label to refer to a particular MAC resource, so the MAC may change (i.e. replace) the actual physical allocation without changing the endpoint identifier.

NOTE 2: A MAC channel may carry both the advanced link and basic link signalling. However, the MAC is not aware of any distinction between advanced link and basic link messages.

## 23.1.3 MS capabilities

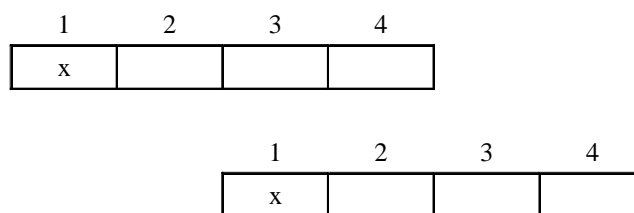
The following clauses describe the capabilities of a frequency full duplex and half duplex MS. All MSs shall provide frequency half duplex capability while an MS may also provide fast switching capability or support frequency full duplex operation.

### 23.1.3.1 Frequency half duplex operation

#### 23.1.3.1.1 Frequency half duplex capability

A frequency half duplex MS has the ability either to transmit on an uplink frequency or receive on a downlink frequency at any time. It is not able to transmit and receive at the same time. This type of MS also requires time to switch from its transmit to receive frequency. This shall be no more than a timeslot duration.

Figure 139 shows the uplink and downlink slots of a single TDMA frame, with "x" marking an example of slots which can be used by a frequency half duplex MS. Only one downlink and the corresponding (same-numbered) uplink slot can be used in a single TDMA frame. If both the uplink and downlink slot in figure 139 are used by a single MS, time division duplex operation can be realized allowing a frequency half duplex MS to support single-slot duplex call services.



**Figure 139: Frequency half duplex operation**

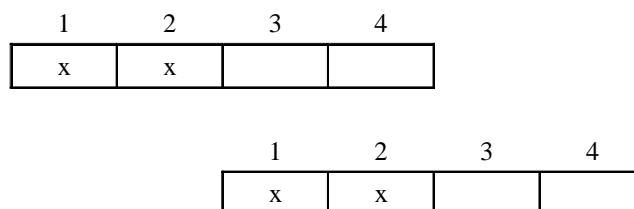
In the example shown, the MS can receive the downlink slot and also transmit in the corresponding uplink slot. It is also possible for a frequency half duplex MS to operate with a multi-slot channel. However, in this case, the BS should not send signalling messages to that MS when the MS is transmitting traffic or transmitting in reserved slots.

### 23.1.3.1.2 Fast switching capability

A frequency half duplex MS may be capable of switching from transmit to receive, and from receive to transmit, between contiguous slots (e.g. capable of transmitting in uplink slot 2 and then receiving in the immediately following downlink slot 1). This type of MS is defined as a fast switching MS. A fast switching MS may fully support e.g.:

- two concurrent single-slot channels; and/or
- a two-slot duplex call service;

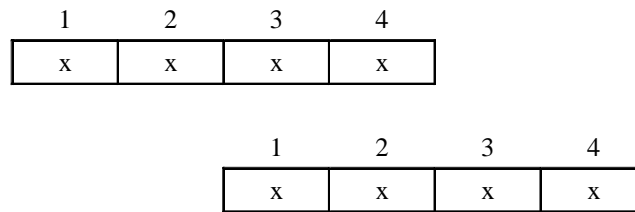
provided that the BS allocates the two slots with adjacent numbers (i.e. slots 1 and 2, or 2 and 3, or 3 and 4, or 4 and 1). Figure 139a shows the uplink and downlink slots of a single TDMA frame, with "x" marking an example of slots which can be used by a fast switching MS.



**Figure 139a: Frequency half duplex operation with fast switching capability**

### 23.1.3.2 Frequency full duplex operation

A frequency full duplex MS has the ability to transmit on an uplink frequency and receive on a downlink frequency at the same time. Therefore, this type of MS can use all timeslots in a TDMA frame. Figure 140 shows the uplink and downlink slots of a single TDMA frame, with "x" marking those slots which can be used by a frequency full duplex MS. Any combination of these slots may be used for a single call or for multiple calls.



**Figure 140: Frequency full duplex operation**

### 23.1.3.3 Basic capabilities of the physical layer

The following performance is expected from the physical layer for a TETRA MS.

An MS shall be capable of changing from one frequency to another frequency in less than 1 timeslot duration.

An MS shall be capable of changing from reception to transmission or from transmission to reception in less than 1 timeslot duration.

An MS shall be capable of a combined frequency change and changing from reception to transmission or from transmission to reception in less than 1 timeslot duration.

A fast switching MS shall be capable of changing from reception to transmission or from transmission to reception between contiguous timeslots. Fast switching capability is optional in the MS.

**NOTE:** When changing from one frequency to another frequency, or when combining a frequency change with a change from reception to transmission or from transmission to reception, a fast switching MS operates like a normal frequency half duplex MS i.e. switching in less than 1 timeslot duration.

A frequency full duplex MS shall be capable of changing reception or transmission frequency (or both) in less than 1 timeslot duration. Frequency full duplex operation is optional in the MS.

An MS should be capable of receiving and decoding the AACH in contiguous timeslots. An MS may be capable of receiving or transmitting full slots of information in contiguous timeslots.

## 23.2 Services provided by the lower MAC

### 23.2.1 Services at the TMV-SAP

In the protocol model, the MAC layer is divided into two sub-layers, i.e. upper and lower MAC, as described in clause 19. The lower MAC shall provide the following services to the upper MAC protocol:

- transfer of MAC PDUs using suitable physical layer bursts in accordance with the chosen TDMA timeslot;
- report of PDU transfer related exceptions;
- signal strength measurement (i.e. RSSI);
- channel coding and scrambling as described in clause 8:
  - Cyclic Redundancy Check (CRC) calculation;
  - Forward Error Correction (FEC) and interleaving of MAC blocks;
  - scrambling and de-scrambling of MAC blocks;
- choice of training sequence and channel coding corresponding to the slot flag value and vice versa;
- control of the transmitted power, frequency, frequency band, duplex spacing and precise time synchronization as described in clauses 6 and 10.



The lower MAC provides these services to the upper MAC via the TMV-SAP. Tables 346 and 347 show the correspondence between service primitives at the TMV-SAP and the associated parameters respectively.

**Table 346: Correspondence between the upper and lower MAC at the TMV-SAP**

Upper MAC Service Primitive	Lower MAC Service Primitive (TMV-SAP)
TMA-UNITDATA request or TMB-SYNC request (BS only) or TMB-SYSINFO request (BS only) or TMD-UNITDATA request	TMV-UNITDATA request
TMA-UNITDATA indication or TMB-SYNC indication (MS only) or TMB-SYSINFO indication (MS only) or TMD-UNITDATA indication	TMV-UNITDATA indication

**Table 347: Parameters used in the TMV-UNITDATA primitive**

Parameter	Request	Indication
MAC block	M	M
MAC block length (see note)	M	M
Logical channel (see note)	M	M
CRC pass/fail indication (see note)	-	M
Scrambling code (see note)	M	-
Report (see note)	-	C
NOTE: Not sent over the air interface.		
Key: M: Mandatory; C: Conditional; -: Not used.		

The TMV-SAP boundary is defined to clarify the protocol description and does not imply any specific MS implementation. The word "shall" is used to describe this SAP and the primitives for traceability reasons in the protocol model, but they are not testable.

Many of the parameters exchanged at the TMV-SAP are not sent over the air interface but may be deduced from the physical layer transmission or reception. For example, the scrambling code is not sent as part of the information content, but modifies the information so that reception with a wrong scrambling code will generate an erroneous CRC and so the information will be discarded. On the contrary, reception with the correct scrambling code will only be affected by the transmission medium errors.

The MAC block is the SDU from the upper MAC. The size of the MAC block shall be equal to the appropriate SDU size for the logical channel being used. For C-plane signalling, the upper MAC shall assure this size by fragmenting/associating suitably and by using the Null PDU and/or fill bits to make the MAC block up to the required size, e.g. the required size is 92 bits for SCH/HU, 268 bits for SCH/F and 124 bits for STCH. For U-plane signalling on STCH, the MAC block shall comprise a single MAC-U-SIGNAL PDU. For TCH, the MAC block shall comprise a single MAC-TRAFFIC PDU. (For TCH/S, this PDU contains one or two speech frames and, for circuit mode data, it contains data equivalent to a full slot.)

The scrambling code passed to the MAC by the MLE shall be a 24-bit field composed of the MCC and MNC as defined in EN 300 392-1 [9], clause 7. The MCC and MNC shall be part of the MLE information contained within the SYNC PDU broadcast by the BS on the BSCH. The upper MAC shall add to this a 6-bit colour code which shall be contained in the SYNC PDU. The combination of MCC, MNC and colour code shall make up the scrambling code which the upper MAC shall pass to the lower MAC via the TMV-SAP. This scrambling code shall correspond to the extended colour code used for scrambling and de-scrambling in the lower MAC as defined in clause 8. The scrambling code shall correspond to the 30-bit extended colour code  $e(1)$ ,  $e(2)$ , ...,  $e(30)$  as shown in figure 141.

10 bits Mobile Country Code (MCC) $e(1) - e(10)$ $e(1) = \text{msb of MCC}$	14 bits Mobile Network Code (MNC) $e(11) - e(24)$ $e(11) = \text{msb of MNC}$	6 bits Colour Code $e(25) - e(30)$ $e(25) = \text{msb of Colour Code}$
--	--	---

**Figure 141: Mapping of scrambling code to extended colour code**

## 23.2.2 PDU mapping of the logical channels at the TMV-SAP

Logical channel definitions are given in clause 9 and an overview of their use may be found in clause 19.

Table 348 defines the mapping of the MAC PDUs defined in clause 21 onto the various logical channels.

**Table 348: Mapping of the MAC PDU onto the logical channels**

MAC PDU	Logical channel(s)	Note
ACCESS-ASSIGN	AACH	MAC internal information
ACCESS-DEFINE	SCH/HD, SCH/F, STCH	
MAC-ACCESS	SCH/HU	TMA-SAP information
MAC-END-HU	SCH/HU	
MAC-DATA	SCH/F, STCH	
MAC-RESOURCE	SCH/HD, SCH/F, STCH	
MAC-FRAG	SCH/HD, SCH/F	
MAC-END	SCH/HD, SCH/F, STCH	
MAC-TRAFFIC	TCH	TMD-SAP information
MAC-U-SIGNAL	STCH	
SYNC	BSCH	TMB-SAP information
SYSINFO	BNCH on SCH/HD, STCH	

## 23.3 Control channel usage

### 23.3.1 Control channel types

This clause describes the MS procedures for using control channels.

#### 23.3.1.1 MCCH

In each cell, one RF carrier shall be defined as the main carrier frequency which shall be broadcast in the SYSINFO PDU on the Broadcast Network Channel (BNCH). The MCCH shall occupy slot 1 of the main carrier frequency. An MS shall locate and receive the downlink MCCH, unless the BS has allocated any common SCCHs.

The BS shall use SCH/HD, SCH/F, BNCH and BSCH for transmitting signalling and data messages on the downlink of the MCCH. An MS shall attempt to receive and decode any paging messages on the downlink MCCH addressed to that individual MS or to one of the MS's valid group addresses. An MS shall also attempt to receive and decode any broadcast signalling messages sent on the downlink of the MCCH.

**NOTE:** Energy economy or dual watch mode and the cell reselection procedures may take precedence over the requirements on the MS to attempt to receive and decode paging messages and broadcast messages on the MCCH, or on a common SCCH.

For uplink access on the MCCH, the MS shall follow the random and reserved access procedures described in clauses 23.5.1 and 23.5.2 respectively. The MS shall use SCH/HU for random access on the uplink of the MCCH and SCH/HU or SCH/F for reserved access on the uplink of the MCCH. The uplink shall occupy only a single slot per frame (i.e. slot 1) for reserved access but may use an extended uplink channel for random access purposes if indicated by the ACCESS-DEFINE or SYSINFO PDU.

The downlink of the MCCH shall not be extended to more than a single slot per frame. A BS in normal mode shall always have an MCCH. However, a BS may assign the MCCH for use as a traffic or assigned control channel in which case the BS enters minimum mode.

The AACH in frames 1 to 17 shall indicate common control in the downlink direction for an MCCH. The contents of the AACH in frames 1 to 17 for the MCCH shall contain one of the following:

- a) Header value = 00<sub>2</sub>:
  - this is the normal case for an MCCH in which both the uplink and downlink are used for common control. "Field 1" shall indicate the access parameters for subslot 1 and "field 2" the access parameters for subslot 2 of the uplink.

- b) Header value =  $01_2$  and "field 1" = UMc (000010<sub>2</sub>):
- the BS may assign the uplink of the MCCH as an assigned SCCH while still maintaining the MCCH on the downlink. In this case, the uplink may be shared between common control and assigned control. "Field 2" shall contain the access parameters for both of the uplink subslots and shall apply to both common and assigned control channels.
- c) Header value =  $10_2$  and "field 1" = UMc (000010<sub>2</sub>):
- this is the same as for case b) above except that the random access parameters in "field 2" shall apply only for MSs using the uplink for assigned control. Any MS in common control mode shall not use the uplink for random access in this case.
- d) Header value =  $11_2$  and "field 1" = UMc (000010<sub>2</sub>) and "field 2" = UMt (xxxxxx<sub>2</sub>):
- the BS may assign the uplink of the MCCH for transmission of traffic while still maintaining the MCCH on the downlink. "Field 2" shall contain the traffic usage marker for the uplink assigned channel.

The AACH for frame 18 shall only indicate the uplink access rights. During normal mode operation, it shall always be assumed that slot 1 on the downlink is for common control as part of the MCCH. Any of the possible header values may be used during frame 18 for an MCCH.

### 23.3.1.2 SCCH

The BS may designate an SCCH for use as a main control channel by a subset of the user population. Alternatively, an SCCH may be allocated to certain MSs for subsequent data transfer. These two cases will subsequently be referred to as common and assigned SCCHs respectively.

#### 23.3.1.2.1 Common SCCH

The BS may operate up to three SCCHs for the purposes of common control signalling. Common SCCHs shall each occupy only one slot capacity on the main carrier and shall be used as the main control channel by a subset of the population. Therefore, a BS may operate up to a maximum of three common SCCHs in addition to the MCCH.

The BS shall indicate the number of common SCCHs in operation on the main carrier by setting a two-bit field in the SYSINFO PDU transmitted on BNCH. This two-bit field maps to the number of common SCCHs in operation on this BS. If no common SCCHs are in operation, only the MCCH in slot 1 shall be available for common control signalling on the main carrier. If one common SCCH is indicated by the BNCH two-bit field, then slot 2 of the main carrier shall be used for this SCCH. If two SCCHs are in operation, slots 2 and 3 shall be used and if three SCCHs are in operation, slots 2, 3 and 4 shall be used.

In idle mode, an MS shall receive either the MCCH (slot 1) or one of the common SCCHs on the main carrier. Therefore, an MS shall receive one of the four downlink slots on the main carrier for common control purposes. On registration or at subscription, an MS shall receive a parameter which indicates to the MS which one of the downlink slots on the main carrier shall be used. If an MS receives this value at subscription and then also is assigned a value at registration, the value given at registration shall be used. The following rule shall then be applied by the MS:

- $N\_SCCH$  = number of common SCCHs in operation:
  - two-bit field transmitted by BS on BNCH, value = 0..3;
- $MS\_SCCH$  = MS SCCH allocation:
  - four-bit field transmitted by BS to MS at registration or received by MS at subscription, value = 0 to 11 (eleven);
- Main carrier downlink slot =  $1 + (MS\_SCCH \bmod (N\_SCCH + 1))$ :
  - value = 1 to 4;
- mod = remainder after integer division.

This rule shall enable the MS to derive the slot to be used on the main carrier from its  $MS\_SCCH$  parameter received at registration or subscription and the number of common SCCHs currently in operation as indicated by the BS on BNCH.

If the MS has not yet registered in this network and has no value from subscription, it shall use the MCCH (i.e. slot 1 on the main carrier).

NOTE: Subscription is applicable only for the MS's home network.

The BS may change the number of common SCCHs by modifying the N\_SCCH parameter. An MS shall decode the BNCH and recognize if N\_SCCH has changed. If N\_SCCH has changed the MS shall re-calculate, according to the above rule, the main carrier slot that it should use for common control signalling. When decreasing the number of common control channels the BS shall not change its SCCH configuration before first transmitting the new configuration on the BNCH. When increasing the number of common control channels the BS shall change its SCCH configuration then transmit the new configuration on the BNCH.

A common SCCH, like the MCCH, shall always occupy only 1 slot per frame on the downlink of the main carrier. The uplink shall occupy only 1 slot per frame for reserved access but may use an extended uplink channel for random access purposes if indicated by the ACCESS-DEFINE or SYSINFO PDU (see clause 23.5.1 for more detailed explanation of random access procedures).

An MS returning to the common control channel after, for example, a traffic channel assignment, shall return to the MCCH or common SCCH that it was using before the assignment unless it has received, in the meantime, a SYSINFO PDU indicating a change in the SCCH configuration. (An MS may return to the common control channel due to the MS deciding to leave the call or as a result of receiving a MAC-RESOURCE or MAC-END message with a "Timeslot assigned" value of 0000<sub>2</sub> to indicate that it should go to the MCCH or appropriate common SCCH.) In this case it shall return to the main carrier slot defined by the new configuration. When decreasing the number of common control channels the BS should transmit the BNCH in all slots of frame 18 before changing the SCCH configuration to ensure that all MSs including those on assigned channels receive the configuration change. When increasing the number of common control channels the BS should change its SCCH configuration then transmit the new configuration on the BNCH.

The AACH for a common SCCH shall contain one of the combinations of elements a) to d) as described for the MCCH during frames 1 to 17 and shall follow the same rules defined for the MCCH for frame 18.

### 23.3.1.2.2 Assigned SCCH

An SCCH may be assigned by the BS for subsequent data transfer in response to an initial random access or after an initial paging message on the MCCH or on a common SCCH. This type of SCCH is referred to as an assigned SCCH. An MS shall be directed to an assigned SCCH by a MAC-RESOURCE or MAC-END PDU (see clause 21) transmitted by the BS. The assigned SCCH may be used by a certain group of MSs for a particular signalling message or data exchange (e.g. packet data); or it may be shared between several MSs each with intermittent bursts of signalling to send.

NOTE 1: The BS may use an assigned SCCH as a general packet data channel supporting advanced links for several MSs, where each MS may be intermittently offering data packets.

An assigned SCCH may be allocated as occupying up to four slots per frame as indicated by the MAC-RESOURCE or MAC-END PDU. If both the uplink and downlink are assigned for this purpose then the uplink for reserved access shall occupy the same-numbered slots as the downlink; i.e. an assigned SCCH cannot be allocated with a different number of slots for the uplink for reserved access and downlink. (An extended uplink channel may be used for random access purposes if indicated by the ACCESS-DEFINE PDU.)

The number of slots allocated to a particular assigned SCCH by the BS may be increased or decreased by sending a MAC-RESOURCE (or MAC-END) PDU on the assigned SCCH.

An MS shall attempt to receive and decode all downlink signalling transmitted by the BS on all allocated slots of an assigned SCCH (within the constraints of the cell reselection procedures, and linearization and transmission requirements). Similarly, the MS may transmit uplink signalling on all allocated slots of the uplink of an assigned SCCH in accordance with the random and reserved access procedures defined in clauses 23.5.1 and 23.5.2 respectively.

NOTE 2: The MS may operate with multi-slot channels without the need for the MS to support frequency full duplex operation. The MS capabilities are indicated in the mobile class ("class of MS" element, see clause 16). If an MS is not frequency full duplex and is operating on a multi-slot channel, the BS should not send signalling messages to that MS when the MS is transmitting in reserved slots.

If the BS allocates an assigned SCCH on the downlink, the AACH in frames 1 to 17 shall contain a header value of  $01_2$ ,  $10_2$  or  $11_2$  and "field 1" shall be equal to UMa (000001<sub>2</sub>). If the BS allocates an assigned SCCH in the uplink direction, the AACH in frames 1 to 17 shall contain a header value of  $01_2$  or  $10_2$  depending on whether the uplink is also to be shared with common control uplink accesses. For a unidirectional assigned SCCH, any control slots in the opposite direction shall also be part of the assigned SCCH for the purposes of applying the general procedures for transmission and reception of signalling messages.

If the BS allocates an assigned SCCH in both directions, the AACH in frames 1 to 17 shall contain a header value of  $01_2$  or  $10_2$  depending on whether the uplink is also to be shared with common control uplink accesses.

The assigned slot(s) during frame 18 may be used for any combination of common or assigned control signalling on the downlink and the AACH shall indicate the uplink access restrictions.

The BS shall always transmit in the downlink slots of an assigned SCCH except during a BLCH. This applies even while there is no signalling information to send. (The BS may send broadcast PDUs (except the SYNC PDU) or Null PDUs during these times.) This is required in order for the MS to carry out correctly its channel maintenance procedures for an assigned channel.

NOTE 3: The BS should send the SYNC PDU on a common control channel or assigned channel only in the defined positions, which are in frame 18 (see clause 9). This is because the SYNC PDU is sent with the synchronization training sequence.

### 23.3.1.3 ACCH

An ACCH is a control channel associated with an assigned traffic channel. There shall be two types of ACCH dependent on the current usage of the assigned channel. When the uplink or downlink of the assigned channel are not in use for traffic, the corresponding assigned slots in frames 1-18 shall be available for control signalling. This control channel is known as a Fast Associated Control Channel (FACCH). When the assigned channel is carrying traffic either in the uplink or downlink direction, only frame 18 is available for control signalling in that direction. This control channel is known as a Slow Associated Control Channel (SACCH).

NOTE 1: A traffic channel may be allocated as bidirectional but sometimes may only carry traffic either in the uplink or downlink direction e.g. for an inter-site call. Then the opposite direction is a FACCH. In this case, therefore, a FACCH will be available in one direction and a SACCH in the other direction.

NOTE 2: When an assigned channel is carrying traffic either in the uplink or downlink direction then, in addition to the SACCH in that direction, capacity may be "stolen" from the circuit in frames 1 to 17 for signalling purposes, without changing the mode of operation (see clause 23.8). Stealing uses the STCH logical channel, whereas the FACCH and SACCH are mapped onto SCH.

An ACCH shall have the same number of slots per frame as the associated traffic channel. The uplink and downlink shall have an equal number of slots per frame (see note 3). Therefore, for a multi-slot traffic channel, the ACCH shall assume the same uplink and downlink slot allocation as assigned for the traffic channel (see note 3).

NOTE 3: The exception is that an extended uplink channel may be used for random access purposes if indicated by the ACCESS-DEFINE PDU.

A receiving MS shall monitor all of the downlink slots of an ACCH (within the constraints of the cell reselection procedures, and linearization and transmission requirements) to receive any addressed messages from the BS for that MS. An MS shall also receive any broadcast messages on the downlink ACCH.

As an option, if the BS indicates that frame 18 extension is allowed (indicated by the "frame 18 extension element" in the SYNC PDU), an MS may receive and decode PDUs on all four slots of frame 18. However, the MS should not attempt to reconstruct any fragmented PDUs on frame 18 slots other than the ACCH for that MS. This restriction applies because an MS cannot know in which slot subsequent fragments will be sent for slots other than the ACCH for that MS. The MS shall not attempt to use random access transmission on slots of frame 18 other than its own ACCH (unless permitted by the "timeslot pointer" element from its own ACCH). The application of the normal procedures for transmission and reception of signalling messages shall apply only to the ACCH (i.e. FACCH and/or SACCH) as indicated by the "timeslot assigned" element in the channel allocation.

An MS transmitting in traffic mode shall attempt to receive and decode downlink slots in frames 1 to 17 when required by the assigned monitoring pattern(s) (given with the channel allocation). This allows the BS to send signalling, for example using the STCH, to a transmitting MS. The MS shall only be expected to adhere to the assigned monitoring pattern(s) within its duplex and switching capability (see clause 23.3.1.4).

An MS transmitting in traffic mode shall attempt to receive and decode the ACCH in frame 18 when required by the assigned monitoring pattern(s). For multi-slot operation, the MS shall attempt to receive and decode at least the highest numbered downlink slot allocated for the circuit mode call in frame 18. (The MS shall also be capable of transmitting in the highest numbered uplink slot in frame 18 in case it has to respond to a paging message from the BS.) Similarly, an MS receiving in traffic mode shall attempt to receive and decode at least the lowest numbered slot allocated for the circuit mode call in frame 18 for SACCH downlink signalling (and it shall be capable of transmitting uplink signalling during the lowest numbered slot in frame 18).

NOTE 4: This means that the MS may operate with multi-slot channels without the need for the MS to support frequency full duplex operation.

When the MS switches out of traffic mode, it shall attempt to receive and decode all allocated slots for downlink ACCH signalling (within the constraints of the cell reselection procedures, and linearization and transmission requirements). Similarly, any of the allocated slots may be used for uplink signalling in accordance with the MAC random and reserved access procedures.

In the case of a downlink FACCH, the AACH in frames 1 to 17 shall contain a header value of  $01_2$ ,  $10_2$  or  $11_2$  and "field 1" shall be equal to  $UMa$  ( $000001_2$ ). In the case of an uplink FACCH, the AACH in frames 1 to 17 shall contain a header value of  $01_2$  or  $10_2$  depending on whether the uplink is also to be shared with common control uplink accesses.

In the case of a bidirectional FACCH, the AACH in frames 1 to 17 shall contain a header value of  $01_2$  or  $10_2$  depending on whether the uplink is also to be shared with common control uplink accesses.

The ACCH in frame 18 may be used for any combination of common or assigned control signalling on the downlink and the AACH shall indicate the uplink access restrictions.

The BS shall always transmit in the downlink slots of an ACCH except during a BLCH. This applies even while there is no signalling information to send. (The BS may send broadcast PDUs (except the SYNC PDU) or Null PDUs during these times.) This is required in order for the MS to carry out correctly its channel maintenance procedures for an assigned channel.

### 23.3.1.4 Monitoring pattern during multi-timeslot traffic operation

The BS may allocate a multi-slot traffic channel for circuit mode data calls. Monitoring pattern information shall be given by the BS along with the channel allocation at call set-up. A transmitting MS shall attempt to receive and decode downlink slots according to the assigned monitoring pattern(s). This allows the BS to send signalling, for example using the STCH, to a transmitting MS. The MS shall only be expected to adhere to the assigned monitoring pattern(s) within its duplex and switching capability. A BS should take this into account when attempting to transmit downlink signalling to a transmitting MS on a multi-slot channel. An MS transmitting on multiple slots per frame without a duplex or fast switching capability shall not be expected to receive signalling on the downlink in between transmitted bursts on the uplink; therefore the BS should only use frame 18 (or the lowest numbered slot in frame 1 - see note 1) for signalling to that MS during transmission.

NOTE 1: The MS will not always be able to receive the lowest numbered downlink slot in the frame 1s indicated by the assigned monitoring pattern(s) e.g. when the MS linearizes or transmits in the highest numbered uplink slot in frame 18.

The following requirements apply to reception in frames 1 to 17 by an MS with a duplex or fast switching capability:

- when an MS with frequency full duplex capability is transmitting in traffic mode on a multi-slot channel, it shall attempt to receive and decode all the downlink slots of the assigned channel, in those frames required by the monitoring pattern(s);
- when an MS with fast switching capability is transmitting in traffic mode on a multi-slot channel, it shall attempt to receive and decode any downlink slots of the assigned channel that it is capable of receiving, in those frames required by the monitoring pattern(s).

In frame 18, the MS shall attempt to receive and decode at least the highest numbered downlink slot of the assigned channel, in those frames required by the monitoring pattern(s) (see clause 23.3.1.3).

NOTE 2: Fast switching capability and frequency full duplex capability are indicated in the "class of MS" element (see clause 16).

### 23.3.2 Discontinuous transmission

In the continuous mode of operation, the BS shall transmit continuously on the main carrier except during a BLCH. (If there is no signalling information to send, the BS may send broadcast PDUs or Null PDUs.) On the other carriers, the BS may ramp down and up during slots on the unused physical channels. However, the inter-slot training sequence (i.e. normal training sequence 3) shall always be present and so this ramping down and up is transparent to the MS operation.

The BS shall indicate continuous or discontinuous operation by setting appropriately the "sharing mode" field broadcast in the SYNC PDU on the BSCH. Three modes of discontinuous transmission are defined:

- carrier sharing;
- MCCH sharing; and
- traffic carrier sharing.

These modes are described in the following clauses.

Discontinuous operation on the main carrier may be used for the purposes of sharing the channel resources between a number of cells. It may be desired to allocate different slots on the main carrier to different cells. This is known as carrier sharing operation. Alternatively, it may be desired to share slot 1 of the main carrier between a number of cells. This is known as MCCH sharing.

Discontinuous operation on carriers other than the main carrier may be used for the purposes of sharing traffic resources between a number of cells. This may apply if the BS uses either mode of discontinuous operation on the main carrier. Otherwise it may apply only to the carriers other than the main carrier. This is known as traffic carrier sharing.

It is optional for the MS to implement the methods for operating with a BS that uses any of the discontinuous modes. The MS shall not attempt to obtain service from a BS that uses a discontinuous mode unless that MS is capable of performing the appropriate procedures.

#### 23.3.2.1 Carrier sharing operation

Carrier sharing operation allows the four slots of the main carrier to be shared between up to four adjacent cells. For example, each of four cells may be allocated one of the four timeslots on the main carrier or each of two cells may be allocated two timeslots each. Interference is avoided by ensuring that all of the cells sharing the carrier do not transmit on the downlink at the same time implying that the BSs sharing the main carrier need to be synchronized in time.

If the slot allocated to a BS is for use as a common control channel (i.e. MCCH or common SCCH), the BS shall transmit on the downlink in all frames for that slot (except during a BLCH). If the slot is for use as a traffic channel or assigned SCCH, the BS need not transmit on the downlink for that slot while it is not assigned. Indeed, a slot may be shared between a number of BSs for allocation as a traffic channel or assigned SCCH.

The slot, frame and multiframe numbering may be independent between the cells sharing the main carrier. This means that all cells sharing a carrier can have a slot 1 for use as the MCCH for that cell.

Carriers other than the main carrier may also be shared between adjacent cells. Therefore the MS designer should see note that the BS may use discontinuous bursts on any of the carriers of a carrier sharing cell.

#### 23.3.2.2 MCCH sharing operation

MCCH sharing allows a number of adjacent cells to share slot 1 of the main carrier for MCCH signalling. Up to 36 cells may share the same MCCH. Each cell has a number of reserved frames during which only the BS for that cell may transmit on the downlink MCCH. The remaining frames which are not reserved by any of the BSs sharing the MCCH may be used as common frames during which any of the BSs may transmit. However the network shall schedule downlink transmissions on common frames to ensure that two BSs do not transmit during the same common frame.

If the SYNC PDU indicates "MCCH sharing", the SYNC PDU shall also indicate the number of reserved frames for this BS using the "TS reserved frames" field. The "TS reserved frames" field shall indicate the number of frames reserved over two multiframe periods as defined in clause 9. The BS shall transmit on the downlink during these reserved frames.

During this mode of operation, the BSs shall also broadcast the location of the common frames by using the "TS\_COMMON\_FRAMES" field in the SYSINFO PDU sent on the BNCH. This field shall contain a bit map of the common frames for either the even-numbered or odd-numbered multiframes as indicated by the "Optional field flag".

In order for this mode of operation to work successfully, the transmission of downlink bursts shall be synchronized in time between the BSs sharing the MCCH. In addition, slot numbering shall be synchronized between the BSs to ensure that they all have a common view of when downlink slot 1 is transmitted. However, frame and multiframe numbering shall be offset in order to avoid collision of bursts transmitted during reserved downlink slots.

The remaining slots on the main carrier may be allocated as common SCCHs in which case the rules for reserved and common frames apply not only to slot 1 but also to those slots allocated as common SCCHs. Then the remaining slots not allocated for main or common secondary control may be shared between the BSs for use as traffic or assigned SCCHs. This sharing is performed on a carrier sharing basis; the rules for reserved and common frames do not apply to assigned channels. A BS need not transmit during these slots if they are not assigned.

On a shared MCCH or common SCCH, the MS shall receive and decode the relevant slot during reserved frames for this BS and during those frames marked as common. It shall use the colour code received in the SYNC PDU on choosing a cell on which to camp in order to de-scramble the PDUs. This ensures that the MS cannot decode those transmissions during common frames on adjacent cells. In addition, the MS shall only use SYNC PDUs which contain the correct colour code for this cell since SYNC is not scrambled using the colour code meaning that an MS could receive SYNC from an adjacent cell. To prevent incorrect operation, only those with the correct colour code shall be interpreted by the MS.

Carriers other than the main carrier may be shared between adjacent cells (on a carrier sharing basis). Therefore the MS designer should see note that the BS may use discontinuous bursts on any of the carriers of an MCCH sharing cell.

### 23.3.2.3 Traffic carrier sharing operation

Traffic carrier sharing allows the four slots of carriers other than the main carrier to be shared between adjacent cells. The BS shall transmit continuously on the main carrier (except during a BLCH). However, it may use discontinuous bursts on the other carriers.

## 23.3.3 Minimum mode operation

Minimum mode operation allows a BS to allocate all four timeslots of the main carrier for traffic or assigned control purposes. Therefore, only frame 18 is available for common control. The following clauses describe the procedures for minimum mode operation which shall apply only to those MSs that are in common control mode and monitoring the MCCH. They do not apply to MSs on an assigned channel (traffic or assigned secondary control).

### 23.3.3.1 Beginning of minimum mode

In the normal mode of operation, the MS shall receive the downlink of the MCCH and shall decode the AACH information. In the normal mode of operation, the MCCH is mapped to slot 1 of the main carrier frequency. The AACH in frames 1 to 17 shall indicate that downlink slot 1 is allocated for common control signalling, with the header set to 00<sub>2</sub> or "Field 1" set to UMc (000010<sub>2</sub>).

The BS may choose to enter minimum mode by allocating slot 1 of the main carrier for some other purpose. The AACH shall indicate that downlink slot 1 is no longer allocated for common control. All MSs in idle mode and currently receiving downlink slot 1 shall recognize that the system has entered minimum mode.

Minimum mode during frame 18 shall be assumed by an MS if the AACH indicates that downlink slot 1 in frame 17 is allocated for some purpose other than common control signalling. If the AACH cannot be decoded in frame 17, then the MS shall assume that the BS is in the mode indicated by the last correctly decoded AACH message in a downlink slot 1. The BS shall not enter minimum mode in frame 18 but may only indicate the beginning of minimum mode in the AACH of frames 1 to 17.



**NOTE:** In order to ensure robust operation, a BS may choose to enter minimum mode several frames before frame 18. This would ensure that all MSs have an increased probability of correctly decoding the AACH and taking the proper action during frame 18.

The BS shall not enter minimum mode while there is future capacity already granted for reserved access on the MCCH. Thus the BS shall wait until any granted slots or subslots on the MCCH have been used (or released by the Null PDU) before entering minimum mode.

### 23.3.3.2 MS operation during frames 1 to 17

During minimum mode, an MS shall receive slot 1 in frames 2 to 17 so that the BS may send signalling to an MS using the stealing channel or fast associated control channel. An MS shall decode the full contents of the slot to check whether the information is addressed to that MS. An MS shall decode the AACH in downlink slot 1 of frames 1 to 17 so that it can detect the end of minimum mode. If the end of minimum mode is detected, the MS shall also decode the full contents of that slot to check whether the signalling message contained is addressed to that MS (except if minimum mode ends in frame 1 in which case the BS should not assume that every MS is able to receive the full contents of the slot). An MS assigned to slot 1 during frame 18 in minimum mode shall decode the full contents of slot 1 in frame 1. All other MSs need only decode the AACH during slot 1 in frame 1.

The BS should not assume that every MS is able to decode slot 1 of frame 1 since an MS assigned to slot 4 in frame 18 may not be able to decode the following slot in frame 1.

### 23.3.3.3 MS operation during frame 18

An MS shall receive one of the four downlink slots in frame 18 as allocated to that MS at registration or subscription. An MS shall be allocated a minimum mode frame 18 slot at registration or subscription and shall receive that assigned downlink slot in frame 18 if the BS has entered minimum mode. The BS, therefore, may sub-divide the MS population at registration between the frame 18 slots for minimum mode operation according to whatever criteria it chooses to apply, or the sub-division may be applied at subscription of the MS population. If an MS has been assigned a minimum mode slot at subscription and then also receives a minimum mode slot at registration, the one received at registration shall be used.

If the MS has not yet registered in this network and has no minimum mode slot from subscription then it shall use downlink slot 1 in frame 18 by default.

**NOTE 1:** Subscription is applicable only for the MS's home network.

**NOTE 2:** A BS may choose not to sub-divide the MS population in minimum mode, but instead may assign downlink slot 1 as the minimum mode frame 18 slot for all MSs.

Frame 18 slots shall be shared between idle MSs for common control channel signalling and MSs on assigned channels which use frame 18 for associated control signalling. The BS may send downlink signalling messages on a downlink slot intended either for an idle MS receiving that slot or for an MS on the assigned channel using that slot for associated signalling. The BS shall indicate the destination for signalling messages with an address in the MAC header.

**NOTE 3:** When an MS obeys a channel allocation command for an assigned channel, it may be permitted to continue to use the MCCH if it is capable of doing so (see clause 23.5.4). If the BS is in minimum mode, and if the assigned channel happens to correspond to the MS's minimum mode frame 18 slot, then there is a possible ambiguity of usage of the downlink slot in frame 18. If this occurs then the MS should not attempt concurrent random access on both the MCCH in minimum mode and the assigned channel. Also the BS should avoid sending ambiguous fragmented signalling in frame 18 or setting up advanced links for that MS on both the MCCH and the assigned channel.

Frame 18 downlink slots shall also be used for broadcast control signalling. The normal mapping of frame 18 downlink slots for BNCH and BSCH as specified in clause 9 shall apply.

### 23.3.3.4 MS operation in energy economy or dual watch mode

During minimum mode, an MS in energy economy or dual watch mode shall not modify its monitoring behaviour. An MS waking up to find that the system is in minimum mode shall not modify its monitoring behaviour. The BS may page an MS in energy economy or dual watch mode even during minimum mode by using the STCH or FACCH in the MS's "awake" frames.

**NOTE:** If an MS in energy economy or dual watch mode on the MCCH perceives that the system is in minimum mode then, when it is required by clauses 23.7.6 or 23.7.7 to receive in frame 18, it receives and decodes slot 1. This applies even if the MS' nominal minimum mode frame 18 slot (as received at subscription or registration) is not slot 1.

### 23.3.3.5 End of minimum mode

During minimum mode, an MS shall continue to receive the AACH on downlink slot 1 of frames 1 to 17. If the AACH indicates that downlink slot 1 is allocated for common control purposes once again, the MS shall recognize that the BS is no longer in minimum mode and that normal mode operation has resumed.

The BS shall not leave minimum mode while there is minimum mode capacity already granted for reserved access in slot 2, 3 or 4 of frame 18. Thus the BS shall wait until any slots or subslots granted in slot 2, 3 or 4 of frame 18 for MSs in common control mode have been used before leaving minimum mode.

### 23.3.3.6 Restrictions on usage of minimum mode

The minimum mode procedures are not applicable for a BS that uses MCCH sharing.

The minimum mode procedures may apply for a BS that uses main carrier sharing. However, in this case, the MS shall always use downlink slot 1 in frame 18 as its minimum mode frame 18 slot, irrespective of any value received at subscription or registration.

The minimum mode procedures apply only to those MSs that are in common control mode and monitoring the MCCH. They do not apply to MSs on an assigned channel. Also, they do not apply to an MS that is receiving a common SCCH. If the AACH information indicates that the downlink slot is not being used for common control purposes, the MS should remain on its common SCCH unless the "number of common secondary control channels in use" field changes in the SYSINFO PDU (BNCH).

It is optional for an MS to be capable of performing the minimum mode procedures. If the BS enters minimum mode, and the MS is not capable of performing the minimum mode procedures, then that MS will not receive service during minimum mode. The MS shall not attempt random access and need not decode slot 1 for signalling messages. The MS shall at least be able to recognize the beginning and end of minimum mode.

## 23.3.4 Independent allocation of uplink and downlink

A BS may allocate uplink and downlink channels for different purposes. This can apply to channels which are assigned for use as a traffic channel or control channel. For example, a traffic channel may be allocated in the downlink direction when there are only receiving mobiles for that cell and the corresponding uplink channel may be allocated for a call which only requires an uplink channel. Some examples are listed below:

- a) circuit mode call X on downlink channel;  
circuit mode call Y on uplink channel;
- b) circuit mode call on downlink channel;  
assigned SCCH on uplink channel;
- c) assigned SCCH on downlink channel;  
circuit mode call on uplink channel;
- d) common control on downlink MCCH (slot 1);  
uplink slot 1 of main carrier allocated for a circuit mode call;
- e) downlink slot 1 of main carrier allocated for a circuit mode call;  
uplink slot 1 of main carrier available for common control.

The allocation of uplink and downlink slots is indicated by the contents of the AACH which is broadcast by the BS on every downlink slot. All of the above examples can be accommodated with the available combinations of the header in the ACCESS-ASSIGN PDU (see clause 21 for more details). Also, when a channel is allocated, the "up/downlink assigned" element in the channel allocation shall inform the MS of any restrictions.

However, for the application of the general procedures for transmission and reception of signalling messages, each control channel (ACCH or SCCH) shall be assumed to occupy any control slots on both the uplink and downlink directions, as indicated by the "timeslot assigned" element in the channel allocation.

Therefore, for example, in case a), any ACCH in each direction shall be shared by the two unidirectional circuit mode calls. Similarly, in cases b) and c), the ACCH and SCCH shall be shared. In cases d) and e), the MSs in the circuit mode call shall share the common control channel.

NOTE: In case a), the two calls X and Y generally involve different MSs. However, it is possible that they may be concurrent calls involving the same MS.

### 23.3.5 Usage of a multi-slot channel

A "channel" or "MAC channel", as used in the MAC protocol, means a common control channel or assigned channel. A common control channel comprises one timeslot per TDMA frame on a pair of radio carrier frequencies (downlink and uplink) so it equates with a physical channel; see clause 9.4.1. An assigned channel may comprise more than one timeslot per TDMA frame on a pair of radio carrier frequencies. It then corresponds to a combination of up to four physical channels, as indicated by the "timeslot assigned" element in the MAC-RESOURCE or MAC-END PDU that sent the MS to the channel.

For the purposes of the procedures for transmission and reception of signalling messages on an assigned SCCH or an ACCH, all the slots comprising a multi-slot channel are equivalent. Downlink signalling messages (including continuation fragments and final fragments) may be sent on any downlink slot appropriate to that channel. Also, when the MS is counting slots on the channel (e.g. for the granting delay or for a reserved access allocation), all the slots appropriate to that channel shall be counted continuously.

This contrasts with the method for a multi-slot circuit mode data service with interleaving depth  $N = 4$  or  $8$ . In this case, when the assigned channel is in traffic mode, multiple single-slot data TCHs (TCH/2,4 or TCH/4,8) shall be operated in parallel in order to obtain the multi-slot TCH transmission. The  $N$ -slot interleaving shall be performed within each single-slot TCH, such that interleaved blocks are separated by three timeslots.

NOTE: The use of multiple single-slot data TCHs for the interleaving ensures that the performance of multi-slot circuit mode data is the same as that for single-slot circuit mode data with the same interleaving depth. This method applies only when the assigned channel is in traffic mode. When the channel is not being used for TCH, the channel reverts to FACCH and the normal signalling methods apply.

## 23.4 General MAC procedures

### 23.4.1 PDU header analysis for signalling messages

#### 23.4.1.1 MAC PDU types

The header of each MAC PDU enables the receiving MAC to interpret its contents correctly (see clause 21 for a full description of the PDUs).

#### 23.4.1.2 Addressing at the TMA-SAP

The TMA-SAP MAC headers generally contain an "Address" element and an element specifying the type of address. This layer 2 address is the source address for an uplink PDU, or the destination address for a downlink PDU.

Another address (when needed) may be contained within the layer 3 part of the message e.g. the called address for an uplink PDU, or the calling address for a downlink PDU. The infrastructure makes the required address conversion between the uplink and downlink PDUs as appropriate.

The usage of TETRA addresses and identities is described in EN 300 392-1 [9], clause 7.

The address in the MAC header shall be a Short Subscriber Identity (SSI/USSI), a Short Management Identity (SMI) or an event label. An SSI/USSI is a 24-bit address specific to a particular TETRA network and is part of the complete TETRA Subscriber Identity (TSI). The 24-bit SMI is part of the TETRA Management Identity (TMI). An event label is a 10-bit MAC address that may be used to replace an SSI or SMI.

The MS procedures throughout clause 23 apply to the requirements for a single TSI family. If an MS contains more than one TSI family (see EN 300 392-1 [9], clause 7), then each family shall meet the MAC protocol requirements independently of other families.

#### 23.4.1.2.1 Downlink message

When the BS transmits a downlink MAC-RESOURCE PDU, it shall use one of the following addresses as appropriate as the destination address:

- an Individual Short Subscriber Identity (ISSI);
- an Alias Short Subscriber Identity (ASSI);
- an Un-exchanged Short Subscriber Identity (USSI), used only until a migrating MS has been assigned a valid address on this network;
- a Group Short Subscriber Identity (GSSI);
- a Short Management Identity (SMI);
- a valid event label (see clause 23.4.1.2.3).

The "address type" element in the MAC header shall indicate whether the address is an SSI (ISSI/ASSI/GSSI), event label, USSI or SMI; and may be used to assign an event label (or a usage marker).

The receiving MS-MAC shall use the contents of the PDU only if it recognizes the address as one of its own valid addresses or event labels. The one exception is that the MS-MAC shall process the MAC header in all received PDUs sufficiently to deduce the length of the PDU, in order to perform dissociation of multiple PDUs sent within a MAC block.

If the MS-MAC receives a PDU with one of its valid addresses or event labels, it shall pass the TM-SDU to the LLC using the TMA-UNITDATA indication primitive. It shall indicate the received address and address type, unless the received address is an event label in which case the MS-MAC shall translate the event label into the corresponding SSI or SMI before passing the information to the LLC.

NOTE 1: The other downlink TMA-SAP PDUs are used for continuations and end of a fragmented TM-SDU, and do not contain addressing information.

NOTE 2: There is no distinction between an ISSI, ASSI or GSSI in the PDU. There is no distinction between an ISSI and an ASSI in the MAC. However, it is assumed that the MS-MAC knows which of its addresses are group addresses. The MS-MAC also knows which of its addresses is the SMI, and it knows whether an address is an USSI.

NOTE 3: The predefined broadcast group address ("all ones" address), as described in EN 300 392-1 [9], clause 7, defines a group to which all MS belong. For example, it may be used as the destination address for CMCE or packet data calls, or it may be used by the BS for sending broadcast signalling messages using the services provided at the TLA-SAP and TMA-SAP.

NOTE 4: After an ASSI has been allocated to the MS, the ISSI remains available and may still be used by the BS if required. The MS therefore continues to recognize its ISSI on the downlink. This applies only on a home network, and not in the case of migration when the MS does not have a valid ISSI for the network.

### 23.4.1.2.2 Uplink message

When the MS-MAC is required to send a C-plane message, it receives a TMA-UNITDATA request primitive from the LLC. This primitive shall contain the appropriate layer 2 address (the main address) and the address type.

The main address in the request primitive shall be one of the following:

- the MSs ISSI or ASSI for the network;
- an USSI, used only by a migrating MS for the initial registration request;
- a GSSI;
- the SMI for the MS.

When the MS-MAC forms a MAC-ACCESS or MAC-DATA PDU, it shall use the main address from the TMA-UNITDATA request primitive in the PDU "Address" element, unless an event label has been assigned for this address (see clause 23.4.1.2.3) in which case it may use the event label when appropriate. The "Address type" in the MAC header shall indicate whether the "Address" element contains an SSI (ISSI/ASSI/GSSI), event label, USSI or SMI.

NOTE 1: The other uplink TMA-SAP PDUs are used for continuations and end of a fragmented TM-SDU, and do not contain addressing information.

NOTE 2: A group address in the MAC header is used on the uplink for the low level group presence indication (see clauses 22.2.1.3 and 22.3.1.2). This is the only case for which a group address is used in the MAC header on the uplink.

NOTE 3: After an ASSI has been allocated to the MS, and while it is still valid, that ASSI should be used in uplink messages in preference to the ISSI.

### 23.4.1.2.3 Event labels

An "event label" is a temporary shortened form of address which replaces a specified SSI (ISSI, ASSI or GSSI) or a specified SMI in the MAC PDUs, and is visible only at the MAC layer. It is valid only on one MAC channel. Its usage is illustrated in figure 142.

Event label 0000000000 (all zeros) may be used by the BS for withdrawing an event label assignment (using "address type" 101<sub>2</sub> or 111<sub>2</sub>). It is not valid for normal use.

Event label 1111111111<sub>2</sub> (all ones) may be used by the BS (with "address type" 101<sub>2</sub> or 111<sub>2</sub>) to indicate that current event labels remain valid after a channel change. It is not valid for normal use.

#### 23.4.1.2.3.1 General usage of event labels

When the BS wishes to assign an event label, it shall use the MAC-RESOURCE PDU, which shall contain both the SSI (respectively SMI) and the assigned event label.

- a) If the BS includes an event label assignment in a MAC-RESOURCE PDU containing a non-fragmented message then:
  - if the BS includes a "channel allocation" element in the MAC-RESOURCE PDU then the event label shall apply on the allocated channel (see note 1);
  - otherwise the event label shall apply on the current channel.

- b) If the BS includes an event label assignment in the MAC-RESOURCE PDU of a fragmented message then the event label shall not apply until the associated MAC-END PDU has been received. Then:
- if the BS includes a "channel allocation" element in the MAC-END PDU then the event label shall apply on the allocated channel (see note 1);
  - otherwise the event label shall apply on the current channel.

If the MS discards the partially reconstructed TM-SDU (as described in clause 23.4.3.1.1) then it shall ignore the event label assignment.

NOTE 1: If the MS does not obey the channel allocation, it ignores the event label assignment.

NOTE 2: For a channel allocation with "allocation type" = 11<sub>2</sub> (Replace + CSS channel), the event label applies only on the assigned channel, not on the CSS channel. (See clause 23.5.4 for a description of the allocation types.)

The MS-MAC may then use the event label (if neither all zeros nor all ones) instead of the corresponding SSI (respectively SMI) as the source address in uplink PDUs sent on this channel; see figure 142. While the event label is valid, it may be used for both basic link and advanced link messages, and for random access, reserved access and STCH.

NOTE 3: Thus, while the event label is valid, it may replace the SSI or SMI in any uplink PDUs sent on this channel. As defined in clause 23.3.5, all the slots comprising a multi-slot assigned channel are equivalent for the purposes of the general signalling procedures. Therefore an assigned event label applies to all slots of a multi-slot assigned channel.

The BS may use the event label as the destination address in downlink PDUs (though the corresponding SSI or SMI may still be used). If the MS-MAC receives a downlink PDU containing a valid event label then it shall process the information contained in that PDU. The MS-MAC shall translate the event label into the corresponding SSI (respectively SMI) before passing the TM-SDU to the LLC.

The event label has a limited lifetime. The MS-MAC shall consider that an assigned event label is no longer valid in the following cases:

- 1) A time T.201 has elapsed since the MS last received a downlink PDU containing that event label. Then the MS-MAC shall revert to using the SSI (respectively SMI).
- 2) The MS receives another event label assignment (other than event label 11111111<sub>2</sub>) on this channel, for the same SSI (respectively SMI). Then, if the received event label is non-zero, the MS-MAC shall accept that new event label; if the received event label = 0, the MS-MAC shall revert to using the SSI (respectively SMI).
- 3) The MS moves to another channel (unless the MS is leaving the channel as a result of a channel allocation message sent with "address type" 101<sub>2</sub> or 111<sub>2</sub> and containing event label 11111111<sub>2</sub>). Then the MS-MAC shall revert to using the SSI (respectively SMI), unless a new event label was assigned with the channel allocation.

NOTE 4: In case 3), the MS discards an event label if it leaves the physical resource for which the event label was assigned i.e. the timeslot or timeslots on the appropriate carrier on this cell. The MS also discards an event label if the width of the channel (i.e. the number of timeslots allocated for the channel) is increased or decreased. As defined in clause 23.4.1.2.3.3, an exception to this definition occurs if the MS obeys a channel allocation command sent with "address type" 101<sub>2</sub> or 111<sub>2</sub> and containing event label 11111111<sub>2</sub>.

An event label is retained if a single-slot channel changes from common to assigned or from assigned to common. If the BS changes the number of common SCCHs then an event label is retained if the MS continues to use the same timeslot on the main carrier, but is discarded if the MS moves to a different timeslot.

An event label is retained when the BS enters and leaves minimum mode even if the MS's minimum mode frame 18 slot is not slot 1.

The BS is responsible for ensuring that it does not re-use an event label for another MS until the valid lifetime has expired.

NOTE 5: Event label assignment is intended primarily for when an advanced link has been set up for the appropriate address. However, its use is not precluded when there is only a basic link.

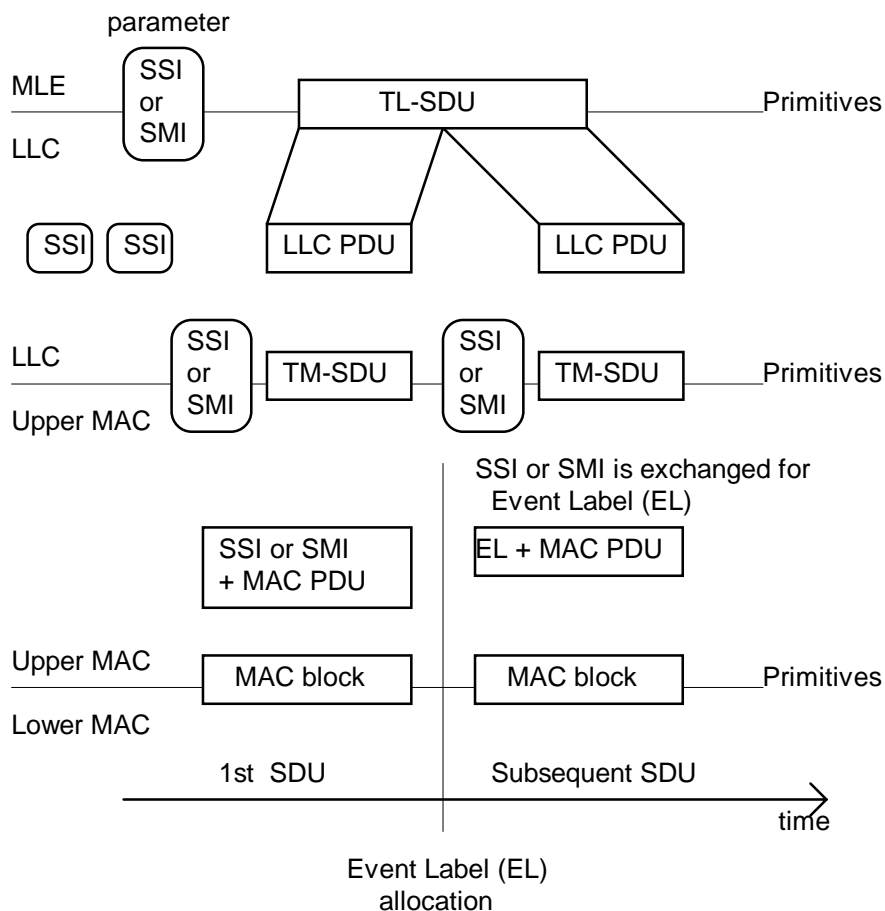


Figure 142: V+D air interface addressing

#### 23.4.1.2.3.2 Usage of event label all zeros

As defined above, the BS may use event label 0 to withdraw an event label assignment (using "address type"  $101_2$  or  $111_2$  i.e. SSI/SMI + Event Label). Event label 0 is not valid for use at other times. Thus it is not valid for use in downlink PDUs with "address type"  $010_2$  or in uplink PDUs with "address type"  $01_2$ . If an MS receives a downlink PDU with "address type"  $010_2$  and event label = 0, it shall ignore the PDU; or, if the BS receives an uplink PDU with "address type"  $01_2$  and event label = 0, it shall ignore the PDU.

#### 23.4.1.2.3.3 Usage of event label all ones

When the BS sends a channel allocation, it may use "address type"  $101_2$  or  $111_2$  (i.e. SSI/SMI + Event Label) with the event label set to  $11111111_2$  to indicate to those MS or MSs addressed by the SSI or SMI that their event labels from the current channel shall be valid on the allocated channel. For an MS addressed by the SSI/SMI, this indicates that all its event labels (for all its addresses) from the current channel shall be valid on the allocated channel - not only the event label corresponding to the SSI/SMI.

NOTE 1: For a channel allocation with "allocation type" =  $01_2$  (Add), the event labels from the current channel are then valid on both the current channel and the allocated channel.

For a channel allocation with "allocation type" =  $11_2$  (Replace + CSS channel), the retention of event labels from the current channel applies only on the assigned channel, not on the CSS channel.

NOTE 2: As an example: the BS could use "address type"  $101_2$  or  $111_2$  with event label  $111111111_2$  if it wishes to replace an assigned channel ("allocation type" =  $00_2$ ) without invalidating the current event labels. This could apply if the BS wishes to change the width of the assigned channel (e.g. for a packet data channel PDCH) or if it wishes to replace the channel for any other reason. If the BS chooses to use the predefined broadcast group address (all ones SSI) then the replacement would apply to all the MSs on the current channel and would allow all the event labels from the current channel to remain valid on the new channel.

If the BS uses "address type"  $101_2$  or  $111_2$  with event label  $111111111_2$  in a MAC-RESOURCE PDU containing a non-fragmented message then the event labels from the current channel shall apply on the channel allocated by the "channel allocation" element in the MAC-RESOURCE PDU. If the BS uses "address type"  $101_2$  or  $111_2$  with event label  $111111111_2$  in a MAC-RESOURCE PDU containing a fragmented message then the event labels from the current channel shall apply on the channel allocated by the "channel allocation" element in the associated MAC-END PDU.

If the MS either:

- does not have any event labels on the current channel; or
- does not obey the channel allocation,

then it shall ignore the event label part of the MAC-RESOURCE PDU - obeying the other procedures within clause 23 as if the PDU had been sent with "address type"  $001_2$  or  $100_2$ .

Event label  $111111111_2$  is not valid for use at other times. Thus it is not valid for use in downlink PDUs unless there is an associated channel allocation. If an MS receives a downlink PDU with "address type"  $101_2$  or  $111_2$  and event label  $111111111_2$  without receiving an associated channel allocation, it shall ignore the event label part of the PDU (obeying other procedures within clause 23 as if the PDU had been sent with "address type"  $001_2$  or  $100_2$ ). Also event label  $111111111_2$  is not valid for use in downlink PDUs with "address type"  $010_2$  or in uplink PDUs with "address type"  $01_2$ . If an MS receives a downlink PDU with "address type"  $010_2$  and event label =  $111111111_2$ , it shall ignore the PDU; or, if the BS receives an uplink PDU with "address type"  $01_2$  and event label =  $111111111_2$ , it shall ignore the PDU.

#### 23.4.1.2.4 Usage of SMI

The SMI is an address specific to a particular TETRA network and is part of the complete TMI. The management identity can be used to address a particular piece of equipment independently from the subscriber identity.

NOTE: The subscriber identities may be transferable, and may be removed from the equipment by the user.

The SMI enables management functions to be performed over the air interface. Alternatively, if the infrastructure knows the correspondence between the equipment and the SSI, it may use the SSI for the management functions, since the management messages can be recognized by the MLE (see clause 18).

The SMI may be numerically equal to an SSI attached either to that MS or to another MS. The SSI and SMI remain distinct because they can be distinguished by the address type in the MAC PDUs.

#### 23.4.1.2.5 Usage of USSI

An USSI is the SSI of an MS from a foreign ITSI. It shall only be used in case of migration, when the MS does not have a valid ISSI or ASSI for the network, and shall only be used for the registration procedure. The USSI shall be equal to the ISSI used by the MS in its home network.

When migrating into a network, the first message sent by an MS shall be a registration request, with the USSI as the layer 2 source address. The home MCC and MNC are included within the layer 3 part of the message.

The USSI is then used on the downlink, in the BS response, as the layer 2 destination address. Also, if the layer 3 reply from the BS is not sent with the MAC response, the USSI will be used again as the layer 2 address when the BS sends the layer 3 reply.

The layer 3 reply to the registration request carries an ASSI for the visiting MS; that new SSI shall then be used by the MS inside the visited network. The allocated ASSI may be (by chance) equal to the USSI, but usually is not.



Sometimes, the USSI may be numerically equal to an SSI or SMI already in use by another MS on the visited network. The signalling messages remain distinct because they can be distinguished by the address type in the MAC PDUs.

Sometimes, the USSI may be numerically equal to the USSI of another migrating MS that is trying to register at the same time. In this case, the downlink signalling messages are not distinct at layer 2. However, the layer 3 reply from the BS contains the MS's home MCC and MNC, and the MM in the MS will discard a received reply if it has incorrect MCC or MNC (see clause 16).

After the MS has received an ASSI, and has sent the LLC response if appropriate, usage of the USSI becomes invalid on this network for as long as the MS has a valid ASSI (see clause 16.4.7); the MS shall not use the USSI in uplink messages and shall not recognize the USSI in downlink messages.

### 23.4.1.3 Addressing at the TMB-SAP

The characteristic of this SAP is that the broadcast information (system information) is implicitly addressed to every MS and, in order to keep the overhead as low as possible, does not contain an address field. The MAC PDU type under the TMB-SAP is distinct from those used under the TMA-SAP (see clause 21). The LLC shall be transparent for system broadcasts. No address is reported by the MAC to the MLE.

**NOTE:** Broadcast messages under the TMB-SAP comprise only the SYNC PDU (i.e. content of BSCH), SYSINFO PDU (i.e. content of BNCH) and ACCESS-DEFINE PDU. They should not be confused with signalling messages addressed to a group of MSs in the downlink using a specific group address at the TLA-SAP and TMA-SAP. Broadcast to all MSs in a cell or wider area may use the predefined broadcast group address ("all ones" address) and the services provided at the TLA-SAP and TMA-SAP (see clause 23.4.1.2.1).

### 23.4.1.4 Addressing at the TMD-SAP

There is no addressing at the TMD-SAP. There may be multiple endpoints in the TMD-SAP which shall be associated with the corresponding CC instance and address used in the set-up phase in the user application.

If the MAC steals from the circuit mode capacity to send C-plane signalling, it shall use TMA-SAP PDUs and addressing.

## 23.4.2 PDU composition for signalling messages

This clause describes the mechanisms whereby PDUs may be transmitted in the MAC blocks in full or half-slot SCH. Three general mechanisms are provided:

- a) Fragmentation:
  - this is the subdivision procedure that shall be used by an MS-MAC or BS in the case that a TM-SDU received from the LLC exceeds the available capacity in a MAC block. The transmission of the TM-SDU is then subdivided between two or more MAC blocks.
- b) Fill bit addition:
  - the length of a MAC PDU is generally represented as a number of octets. "Fill bits" shall be used when the PDU does not fully occupy the indicated PDU length. They are used to make up the difference between the actual PDU content and the indicated length, and they also show the exact end of the TM-SDU.
- c) Association:
  - this is the procedure that may be used by an MS or BS for sending two or more PDUs within a single MAC block.

The reverse procedures (called reconstruction, fill bit deletion and dissociation respectively) are described in clause 23.4.3.

### 23.4.2.1 Fragmentation (TMA-SAP only)

Fragmentation is the procedure that shall be used by an MS-MAC or BS in the case that a TM-SDU received from the LLC exceeds the available capacity in the MAC block. The MAC subdivides the TM-SDU into a number of fragments, where each fragment is sent within one MAC PDU. The whole TM-SDU contains only a single LLC header. This procedure is illustrated in clause 21, figure 99. Fragments are not numbered, and so they shall be sent in sequence. If an error occurs during transmission then the MAC procedure fails (and the LLC has to request a re-transmission of the whole TM-SDU). From the point of view of the higher layers, the process is the same as if the TM-SDU had been transmitted in a single MAC block.

The first fragment of a TM-SDU shall be sent with a full MAC header (MAC-RESOURCE PDU on the downlink, MAC-ACCESS or MAC-DATA PDU on the uplink). Whereas continuation fragments (MAC-FRAG PDU) and the final fragment (MAC-END or MAC-END-HU PDU) shall be sent with a reduced header (see clause 21). In particular, only the full MAC header contains addressing information.

Fragmentation applies only to subdivision of the actual TM-SDU. The MAC header cannot be subdivided between MAC blocks.

On the downlink, the BS may temporarily interrupt a fragmented message to send other signalling whereas, on the uplink, the MS-MAC shall not interleave any other signalling with a fragmented TM-SDU.

NOTE 1: The fragmentation procedure is intended for use for basic link messages, if a TM-SDU exceeds the capacity of the MAC block. It is recommended that the MS/BS does not fragment advanced link messages.

NOTE 2: The fragmentation procedure is not intended for very long messages. It is recommended that fragmentation is not used for TL-SDUs exceeding approximately 133 octets (if using FCS) or 137 octets (if not using FCS) i.e. MAC-ACCESS + four full slots. And fragmentation cannot be used for TL-SDUs exceeding 324 octets (if using FCS) or 328 octets (if not using FCS). Instead, the MLE should set up an advanced link (or use an existing advanced link).

It is recommended that the MLE uses the optional FCS if it sends long messages on the basic link (but not when it sends short signalling messages).

NOTE 3: There is no MAC acknowledgement or MAC re-transmission of a fragmented TM-SDU. Acknowledgements and retransmissions are under the control of the LLC.

#### 23.4.2.1.1 Fragmentation of downlink TM-SDU

When the BS wishes to send a TM-SDU that does not require fragmentation, it shall send the entire TM-SDU within the MAC-RESOURCE PDU.

When the BS wishes to send a TM-SDU that exceeds the available capacity within a MAC block, it may subdivide the TM-SDU into fragments, which shall be sent on this control channel, in the following sequence:

- a) the first fragment shall be sent using the MAC-RESOURCE PDU;
- b) any continuation fragments shall be sent using  $n \times$  MAC-FRAG PDUs (where  $n \geq 0$ );
- c) the final fragment shall be sent using the MAC-END PDU.

Since the MAC-END PDU header is longer than the MAC-FRAG header, there may be some cases when the remainder of the TM-SDU fits within MAC-FRAG but would not fit within MAC-END. In these cases, the BS should send the remaining data within MAC-FRAG (with fill bits if necessary) and then send an empty MAC-END PDU to complete the message.

When the BS has sent one or more fragments of a fragmented message, it may temporarily interrupt the transmission if necessary to send a TMB-SAP broadcast message or a non-fragmented TMA-SAP message (but not a fragmented message). However, the MS-MAC receiving the fragmented message will discard a partially received TM-SDU if it does not receive a fragment in at least every  $N \cdot 203^{\text{th}}$  slot on this downlink control channel (see reconstruction by MS given in clause 23.4.3.1.1).

The MAC PDU structure allows only one first fragment or continuation fragment to be sent per MAC block. This shall be sent as the last PDU in the MAC block. In the MAC-RESOURCE PDU that contains the first fragment, the "Length indication" element shall be set to 111111<sub>2</sub>.

The BS may abort a fragmented transmission at any time before transmission of MAC-END by sending no more fragments of the message.

If the BS wishes to send slot granting information with a fragmented message, the grant may be included in either the MAC-RESOURCE or the MAC-END PDU.

If the BS wishes to send channel allocation information with a fragmented message, then this information shall be included within the MAC-END PDU and shall not be included within the MAC-RESOURCE PDU.

NOTE: For a multi-slot control channel, all the downlink slots comprising that control channel are equivalent. In particular, the continuation and final fragments may be transmitted on any downlink slot appropriate to that channel (as indicated by the "Timeslot Assigned" element from the MAC-RESOURCE or MAC-END PDU that allocated the channel); they are not restricted to the same timeslot number as the first fragment.

#### 23.4.2.1.2 Fragmentation of uplink TM-SDU

When the MS-MAC wishes to send a TM-SDU that does not require fragmentation, it shall send the entire TM-SDU within the MAC-ACCESS PDU or the MAC-DATA PDU. MAC-ACCESS applies if the MS-MAC is using random access or a subslot granted by the BS. MAC-DATA applies if the MS-MAC is using a full slot granted by the BS. After transmission in a granted subslot or slot, the MS-MAC shall inform the LLC that the TM-SDU has been sent (using the TMA-REPORT indication primitive).

The MS-MAC may perform fragmentation of a TM-SDU using any of the following transmission forms:

- i) MAC-ACCESS + MAC-END-HU;
- ii) MAC-ACCESS +  $n \times$  MAC-FRAG + MAC-END  $0 \leq n \leq 9$ ;
- iii) MAC-DATA + MAC-END-HU;
- iv) MAC-DATA +  $n \times$  MAC-FRAG + MAC-END  $0 \leq n \leq 9$ ;

Form i) or ii) shall apply if the MS-MAC is using random access to start the process or if the MS-MAC is granted a subslot by the BS. Form iii) or iv) shall apply if the transmission starts in a full slot granted by the BS.

When the MS-MAC wishes to send a TM-SDU, it shall first determine whether fragmentation is required and, if so, the required capacity to carry the TM-SDU.

For MAC-ACCESS, fragmentation is required for a TM-SDU exceeding 62 bits. If fragmentation is required, the MAC-ACCESS can carry a first fragment of 56 bits of TM-SDU.

For MAC-DATA, fragmentation is required for a TM-SDU exceeding 231 bits (and the MAC-DATA can carry a first fragment of 231 bits of TM-SDU).

NOTE 1: The above numbers assume that the first fragment is the only PDU within the MAC block. If association has occurred within the subslot or slot, the available size is reduced correspondingly. Fragmentation can only be used after association if the complete MAC header, plus at least one bit of TM-SDU, can be sent within the MAC block.

NOTE 2: The above numbers assume the use of an SSI or SMI in the MAC header. If an event label is used, then the available sizes are increased by 14 bits.

If the remainder of the TM-SDU does not exceed 85 bits, then the transmission can be completed with a single subslot (MAC-END-HU PDU).

Otherwise, the MS-MAC shall determine the required number ( $N = n + 1$ ) of full slots to send the remainder ( $R$  bits) of the TM-SDU:

- if  $R \leq 258$ ,  $N = 1$ ;
- if  $R > 258$ ,  $N = 2 + (R-259) \text{ DIV } 264$ ;

where DIV represents integer division, rounded down.

The MS-MAC shall use the following procedure for sending a fragmented TM-SDU:

- The MS-MAC shall send the first fragment in the MAC-ACCESS or MAC-DATA PDU, setting the "fill bit indication" to indicate that no fill bits are present and the optional elements to include the "Capacity request" indicating:
  - start of fragmentation;
  - the reservation requirement for the remainder of the TM-SDU (and for any other messages which the MS has ready to send for this address on this control channel).
- If the MS-MAC requested only a subslot then it shall send the final fragment in the first subslot or full slot granted for this address on this control channel (using MAC-END-HU or MAC-END respectively). The "fill bit indication" shall be used to indicate whether or not fill bits are used within the PDU.
- If the MS-MAC requested one or more full slots then it shall send further fragments in full slots on this control channel, using  $n$  MAC-FRAG PDUs and then one MAC-END PDU. It shall send fragments in any slots already granted for this address, and in slots as they are granted by the BS for this address (in one or more slot grants).

NOTE 3: The BS is permitted to use more than one slot grant when granting the requested slots for the further fragments, in which case the granted slots need not be continuous on this uplink control channel. However, see timer T.202 in procedure b) below.

- For the first  $n-1$  MAC-FRAG PDUs, the MS-MAC shall include fragments of 264 bits of the TM-SDU (with no fill bits). For the last MAC-FRAG, the MS-MAC shall include the next 264 bits of the TM-SDU, or the remainder of the TM-SDU if this is less than 264 bits (with the "fill bit indication" used to indicate the end of the user data).
- The MS-MAC shall include the remaining part (if any) of the TM-SDU in the MAC-END PDU. The "fill bit indication" shall be used to indicate whether or not fill bits are used within the PDU.

NOTE 4: The ISSI and its associated ASSI are equivalent for the purposes of the slot granting procedure (so the MS should use any subslot or slot(s) granted on its ISSI for a TM-SDU being sent with its ASSI, or vice versa). Similarly, an event label and its corresponding address are equivalent for the purposes of the slot granting procedure. Also, a newly assigned ASSI is equivalent to the replaced ASSI or USSI for the purposes of the slot granting procedure.

The transmission process described above shall be continued until one of the following cases a) to d) occurs:

- a) The MS-MAC sends the MAC-END-HU or MAC-END PDU.

The MS-MAC shall then inform the LLC that the TM-SDU has been sent by reserved access (using the TMA-REPORT indication primitive).

The remainder (if any) of the MAC block shall be completed either by a Null PDU (plus fill bits) or by a MAC-ACCESS or MAC-DATA PDU by association as appropriate.

If the MS has further signalling to send for this address on this control channel, then the MS-MAC shall include the reservation requirement in the MAC-END-HU/MAC-END (or in the last PDU in the MAC block if association is performed).

- b) The MS-MAC does not have any capacity granted for this address on this control channel and a time  $T_{202}$  has elapsed since:
- it last transmitted a fragment; or
  - it last received a slot granting element for this address on this control channel containing the instruction to "Wait for another Slot Grant",

whichever is the later.

The MS-MAC shall then inform the LLC that the transmission has failed (using the TMA-REPORT indication primitive), and shall discard the TM-SDU.

NOTE 5: After a fragmentation failure, the LLC is responsible for sending a re-transmission if appropriate.

- c) The MS-MAC asked for full slot reservation, and it receives a subslot grant for this address.

The MS-MAC shall then inform the LLC that the transmission has failed (using the TMA-REPORT indication primitive), and shall discard the TM-SDU. The MS-MAC may use the granted subslot to send another TM-SDU.

- d) The MS-MAC receives a TMA-CANCEL request from the LLC, cancelling transmission of this message. In this case, the MS-MAC shall discard the TM-SDU (reporting to the LLC that the message was not completely sent).

If the MS-MAC is granted any further subslots or slots, it may send another TM-SDU.

NOTE 6: Where procedures a), b) and c) use the expression "for this address", the ISSI and its associated ASSI are equivalent for the purposes of this procedure. Similarly, an event label and its corresponding address are equivalent for the purposes of this procedure. Also, a newly assigned ASSI is equivalent to the replaced ASSI or USSI for the purposes of this procedure.

### 23.4.2.1.3 Fragmentation in minimum mode

Fragmentation is possible in minimum mode. However, long delays may be introduced, particularly for fragmentation over more than two MAC blocks. Therefore, an MS or BS may choose not to perform fragmentation during minimum mode, and the BS may (as always) choose not to grant slots to an MS for continuation of a fragmented message.

When in minimum mode, the BS should not attempt fragmentation (other than within one slot on stealing channel STCH) of a message addressed to an MS that is in energy economy or dual watch mode.

#### a) Downlink TM-SDU

The general procedure for downlink fragmentation, described in clause 23.4.2.1.1, applies during minimum mode except that, when sending a fragmented message to an MS, the only MAC blocks that the BS may use for MAC-FRAG or MAC-END are those in the MS's designated minimum mode frame 18 slot. The MS-MAC receiving the fragmented message will discard a partially received TM-SDU if it does not receive a fragment in at least every  $N_{203}$ 'th frame 18.

NOTE 1: Not all MSs will receive all AACH blocks, so there is some uncertainty about exactly when a particular MS enters and leaves minimum mode. Therefore, if the BS is in process of sending a fragmented message when it enters or leaves minimum mode, it may prefer to abort the transmission.

NOTE 2: The fragmentation procedure defined above applies only when the MAC-RESOURCE PDU is sent on SCH/F or SCH/HD (in slot 1 of frames 2 to 17 if the downlink is in FACCH or assigned SCCH, or in the MS's minimum mode frame 18 slot). If the MAC-RESOURCE PDU is sent on STCH then the fragmentation procedure defined in clause 23.4.2.1.7 applies.

**b) Uplink TM-SDU**

During minimum mode, the MS-MAC shall follow the defined minimum mode rules for monitoring and decoding the downlink for signalling messages (e.g. for receiving slot grants from the BS).

The general procedure for uplink fragmentation, described in clause 23.4.2.1.2, applies (although, since time T.202 is counted in downlink signalling opportunities, in minimum mode the absolute time is 18 times its usual value).

**23.4.2.1.4 Fragmentation on time-shared control channel****a) Downlink TM-SDU**

The general procedure for downlink fragmentation, described in clause 23.4.2.1.1, applies on a time-shared MCCH except that, when sending a fragmented message to an MS, the only MAC blocks that the BS may use for MAC-FRAG or MAC-END are those in the reserved frames for this BS, not the common frames. The MS-MAC receiving the fragmented message will discard a partially received TM-SDU if it does not receive a fragment in at least every N.203<sup>th</sup> reserved frame.

**b) Uplink TM-SDU**

On a time-shared MCCH, the MS-MAC shall follow the defined rules for monitoring and decoding the downlink for signalling messages (e.g. for receiving slot grants from the BS). The normal procedure for uplink fragmentation, described in clause 23.4.2.1.2, applies (although, since time T.202 is counted in downlink signalling opportunities, on a time-shared control channel the absolute time is greater than on a non-time-shared channel).

**23.4.2.1.5 Fragmentation on assigned channel if downlink is in SACCH****a) Downlink TM-SDU**

In frames 1 to 17, fragmentation may be performed on the stealing channel within one slot (see clause 23.4.2.1.7). Fragmentation may also be performed on the SACCH in frame 18.

NOTE 1: Long delays may be introduced for fragmentation over more than two frame 18s. Also, transmission of a fragmented message on SACCH should be aborted if the BS needs to send a fragmented message on the STCH of that assigned channel. Therefore, the BS may choose not to perform fragmentation on the SACCH in frame 18.

The general procedure for downlink fragmentation, described in clause 23.4.2.1.1, applies on the SACCH in frame 18 with the following differences:

- 1) When sending a fragmented message on SACCH to an individual MS that is currently transmitting traffic on the uplink, the only MAC blocks that the BS may use for the message are those in the highest numbered downlink slot of the assigned channel, in those frame 18s that the MS is required to receive according to the assigned monitoring pattern(s). The MS-MAC receiving the fragmented message will discard a partially received TM-SDU if it does not receive a fragment in at least every N.203<sup>th</sup> frame 18 where it is required to receive.

NOTE 2: The above procedure applies only for an individually addressed message. If the BS needs to send a group addressed fragmented message when the downlink is in traffic and an MS is transmitting traffic on the uplink then the BS follows procedure 2).

NOTE 3: If the BS wishes to abort a fragmented transmission on SACCH to an individual MS that is currently transmitting traffic on the uplink, it should either wait for the appropriate number of multiframe (e.g.  $N.203 \times 3 / \text{number of monitoring patterns}$ ) before sending another fragmented message on SACCH or otherwise send a MAC-RESOURCE PDU indicating start of fragmentation in the highest numbered downlink slot of the assigned channel in a frame 18 where the MS is required to receive.

- 2) When sending a fragmented message on SACCH to other MSs, the only MAC blocks that the BS may use for MAC-FRAG or MAC-END are those in the lowest numbered downlink slot of the assigned channel in frame 18. The MS-MAC receiving the fragmented message will discard a partially received TM-SDU if it does not receive a fragment in at least every N.203<sup>th</sup> frame 18.

NOTE 4: As defined in clause 23.3.1.3, an MS receiving in traffic mode on a multi-slot channel is normally required to receive only the lowest numbered slot in frame 18. Therefore, when sending a fragmented message on SACCH to MS(s) that are receiving in traffic mode on a multi-slot channel, the BS should send the first fragment in the lowest numbered slot of the assigned channel in frame 18. Continuation and final fragments sent on SACCH to any MS that is not transmitting traffic on the uplink may be sent only in the lowest numbered slot of the assigned channel in frame 18.

NOTE 5: The BS should see note the procedures used by an MS for reconstruction if the MS switches in or out of traffic transmit mode or sees the downlink leave SACCH (see clause 23.4.3.1.5, paragraph before see note 1 and paragraph before see note 4).

NOTE 6: In case of propagation errors, there is some uncertainty about exactly when a particular MS sees the channel enter or leave SACCH. Therefore, if the BS is in process of sending a fragmented message when it enters or leaves SACCH, it may prefer to abort the transmission.

#### b) Uplink TM-SDU

In frames 1 to 17, if an MS is transmitting traffic on the uplink then it may perform fragmentation on the stealing channel within one slot (see clause 23.4.2.1.7).

Fragmentation may be performed by any MS on the uplink SACCH or FACCH. The general procedure for uplink fragmentation, described in clause 23.4.2.1.2, applies although, since time T.202 is counted in downlink signalling opportunities, the absolute time is 18 times its usual value. If a fragmentation on uplink SACCH is being performed by an MS that is transmitting traffic on the uplink then the absolute time of T.202 is also modified by the monitoring pattern(s).

NOTE 7: Time T.202 is counted in downlink signalling opportunities. However, the BS may choose to send a slot grant by stealing from the downlink TCH.

### 23.4.2.1.6 Fragmentation on assigned channel if downlink is in FACCH or assigned SCCH

#### a) Downlink TM-SDU

The general procedure for downlink fragmentation, described in clause 23.4.2.1.1, applies when an assigned channel is not in downlink traffic with the following difference:

- When sending a fragmented message to an individual MS that is currently transmitting traffic on the uplink, the only MAC blocks that the BS may use for MAC-FRAG or MAC-END are those in the downlink slots where the MS is required to look for further fragments (as defined in clause 23.4.3.1.6 procedure a). The MS-MAC receiving the fragmented message will discard a partially received TM-SDU if it does not receive a fragment in at least every N.203<sup>th</sup> slot where it is required to look for further fragments.

NOTE: The above procedure applies only for a message individually addressed to an MS that is currently transmitting traffic on the uplink. If the BS needs to send other fragmented messages when the downlink is not in traffic then the BS follows the general procedure for downlink fragmentation (so continuation and final fragments may be transmitted on any downlink slot appropriate to the assigned channel). This applies even if the uplink is in traffic.

#### b) Uplink TM-SDU

In frames 1 to 17, if an MS is transmitting traffic on the uplink then it may perform fragmentation on the stealing channel within one slot (see clause 23.4.2.1.7).

Fragmentation may be performed by any MS on the uplink SACCH or FACCH. The general procedure for uplink fragmentation, described in clause 23.4.2.1.2, applies (although, if a fragmentation on uplink SACCH is being performed by an MS that is transmitting traffic on the uplink then the absolute time of T.202 is modified by the monitoring pattern(s)).

### 23.4.2.1.7 Fragmentation on stealing channel

On the stealing channel STCH, fragmentation is only permitted within one slot. Neither the MS nor the BS shall attempt to perform fragmentation over more than one stolen slot.

The procedure for transmission on STCH (including fragmentation) is described in clause 23.8.4.

### 23.4.2.2 Fill bit addition

Fill bits shall be added when the actual size of the MAC PDU is less than the PDU length indicated in the MAC header, or less than the available capacity of the MAC block. Fill bit addition applies only to TMA-SAP PDUs.

If fill bits are added, the MAC shall set the "fill bit indication" in the MAC header to 1. In order to add fill bits within a PDU, the MAC shall:

- add a bit "1" immediately following the last bit of the TM-SDU data;
- complete as appropriate with bits set to "0":
  - if a length indication is included in the MAC header, then complete with 0 to 6 bits set to "0" until the size of the PDU corresponds to the indicated length or the available capacity of the MAC block (if that is less than the indicated length);
  - if a length indication is not included in the MAC header (or if the length indication is set to 111110<sub>2</sub>), then complete with the required number of zeros to fill the MAC block.

Fill bits inserted after a Null PDU to complete the MAC block shall be set to "0", except for the first bit after the Null PDU which shall be set to "1".

When there is not enough space to insert a Null PDU in the remainder of a MAC block, the MAC block shall be completed such that the first bit after the user data shall be set to "1" and the following bits shall be set to "0".

**NOTE:** In this procedure (i.e. when there is not enough space to insert a Null PDU), the MAC uses the normal method for indicating whether there are fill bits inserted within the last indicated PDU length. Thus, if the actual size of the last MAC PDU in the MAC block is less than the indicated PDU length then the MAC sets the "fill bit indication" to 1; if the actual size of the last MAC PDU in the MAC block is equal to the indicated PDU length then the MAC sets the "fill bit indication" to 0. In either case, the recipient discards the bits added following the end of the indicated length of the last MAC PDU.

The procedure for fill bit addition is valid for both MS and BS.

### 23.4.2.3 PDU association

PDU association may be used when several small PDUs can be fitted into a single MAC block for transfer across the air interface. The PDUs are independent. And the BS may associate PDUs addressed to different MSs within one MAC block. However, the MS shall not associate PDUs sent using different addresses within one MAC block.

**NOTE 1:** The MSs ISSI and its associated ASSI are equivalent for the purposes of PDU association by an MS (so the MS is not precluded from performing PDU association for PDUs sent using its ISSI and ASSI). Similarly, an event label and its corresponding address are equivalent for the purposes of PDU association by an MS. Also the MS is not precluded from performing PDU association of PDUs sent using a newly assigned ASSI with PDUs sent using the replaced ASSI or USSI.

However, an MS is not permitted to associate PDUs sent using its SMI with PDUs sent using an SSI within a single MAC block; also an MS is not permitted to associate PDUs from multiple TSI families within a single MAC block. These restrictions may possibly be relaxed in future editions of the present document in the case of the final slot of an MS's requested reserved capacity.

The MS is not permitted to associate PDUs sent using a GSSI with PDUs sent using another address.

The association procedure is illustrated in clause 21, figure 97.



Each PDU shall contain its own header and each TMA-SAP PDU, except possibly the last in the MAC block, shall indicate the length of the PDU as a number of octets. The header of the next PDU shall immediately follow the end of the current PDU. (Within a PDU, fill bits shall be inserted as required.) If there are no more PDUs to follow, a special message (the Null PDU) may be used if it fits within the remaining space in the MAC block. If there are unused bits, they shall follow the rules for fill bit addition.

This procedure is valid for both MS and BS.

In order to associate, the MAC shall:

- a) prepare a PDU:
  - for a TMA-SAP PDU, the MAC shall place the relevant header in front of the TM-SDU, including the PDU length in octets (except in the cases see noted below); the number of octets is rounded up to the next integer value of  $(\text{PDU size in bits})/8$ ;
  - for a TMB-SAP PDU, the size of the PDU is implicit from the MAC header;
- b) if the PDU does not completely fill the MAC block then:
  - if the size of the remainder of the MAC block  $<$  appropriate Null PDU size (see below) then the MAC shall complete the MAC block such that the first bit after the user data shall be set to "1" and the following bits shall be set to "0"; or
  - if the size of the remainder of the MAC block  $\geq$  appropriate Null PDU size (see below) then the MAC shall either:
    - repeat step a) with another PDU; or
    - use the Null PDU and complete the remainder (if any) with fill bits.

For the downlink, the Null PDU size to be used for the comparison in b) shall be 16 bits. For the uplink, the comparison in b) shall be performed using the Null PDU size that corresponds to an address length of 24 bits. This is 36 bits in a subslot, or 37 bits in a full slot or on STCH. This rule shall apply even if the MS has been assigned an event label.

Association shall not be performed if the remainder of the MAC block is less than the size of the appropriate Null PDU, even if the MAC has a PDU to send that is shorter than the Null PDU.

NOTE 2: The "Length indication" element in the MAC header refers to the size of the complete MAC PDU in octets (rounded up), not to the length of the TM-SDU. The length of the TM-SDU is then known, since the TM-SDU follows immediately after the MAC header.

The required PDU length in octets is:

- $1 + ((\text{BITS} - 1) \text{ DIV } 8)$ , where BITS is the PDU size in bits.

There will be some cases when the PDU only just fits within the MAC block so that, after rounding up, the "length indication" may indicate a value which exceeds the available capacity of the MAC block.

NOTE 3: In the present document, the only TMB-SAP PDU for which association may apply is ACCESS-DEFINE.

When a BS performs fragmentation, it shall send the first fragment and continuation fragments as the last PDU in a MAC block. Or, when an MS has further signalling to send, it shall include the reservation requirement in the MAC header of the last (non-Null) PDU in a MAC block. In both these cases, the PDU length cannot be indicated in the MAC header. Also, when an MS-MAC does not require to perform association within an uplink subslot, it should not include the "length indication" element in the MAC-ACCESS PDU except when it needs to send the Null PDU in a subslot.

In all three cases, the PDU shall be deemed to fill the remainder of the MAC block, and the length of the TM-SDU, or TM-SDU fragment, shall be indicated by use of the "fill bit indication" and any fill bits.

## 23.4.3 PDU decomposition for signalling messages

### 23.4.3.1 Reconstruction (TMA-SAP only)

This procedure is the opposite to fragmentation which is performed by the sender as described in clause 23.4.2.1.

#### 23.4.3.1.1 Reconstruction of downlink TM-SDU

The MS-MAC shall receive the downlink slots appropriate to the relevant control channel (within the constraints of the energy economy or dual watch regime and the cell reselection procedures, and linearization and transmission requirements).

On receipt of a MAC-RESOURCE PDU containing one of its valid addresses or event labels, the MS-MAC shall perform the following actions relating to the TM-SDU. Other actions may be performed relating to other elements in the MAC header.

- a) If the MAC-RESOURCE PDU contains "Length indication"  $\neq$  11111<sub>2</sub>, indicating no fragmentation, then the MS-MAC shall deliver the TM-SDU (if any) to the LLC using the TMA-UNITDATA indication primitive.
- b) If the MAC-RESOURCE PDU contains "Length indication" = 11111<sub>2</sub>, indicating the start of fragmentation, then the MS-MAC shall store the TM-SDU fragment. (The length of the first fragment is indicated only by the "fill bit indication" and any fill bits.)

The MS-MAC shall then receive all the downlink slots on this control channel, looking for continuation fragments or for the end of the fragmented data i.e. MAC-FRAG or MAC-END PDU respectively.

On receipt of a MAC-FRAG PDU, the MS-MAC shall append the TM-SDU fragment to the already received fragment(s). (The length of a continuation fragment is indicated only by the "fill bit indication" and any fill bits.) The MS-MAC shall then continue to monitor the control channel for further MAC-FRAG PDUs or for the MAC-END PDU.

On receipt of a MAC-END PDU, the MS-MAC shall append the TM-SDU fragment to the already received fragment(s). (The length of the final fragment is indicated by the combination of the "Length indication", the "fill bit indication" and any fill bits.) The MS-MAC shall then deliver the reconstructed TM-SDU to the LLC using the TMA-UNITDATA indication primitive.

NOTE: Occasionally the MAC-END PDU will contain no user data, in which case the already assembled fragments comprise the complete TM-SDU. On receipt of MAC-END, the MS-MAC delivers the TM-SDU to the LLC.

The MS-MAC shall continue this process until it receives the MAC-END PDU, or until one of the following occurs:

- i) it receives any MAC-RESOURCE PDU on this control channel containing "Length indication" = 11111<sub>2</sub> (for any address, not only one of its own addresses or event labels);
- ii) it fails to decode a SCH/HD or SCH/F MAC block on this control channel;
- iii) it has received N.203 consecutive slots on this control channel without receiving a fragment of its TM-SDU.

In all three cases, the MS-MAC shall discard the partially reconstructed TM-SDU. In case i), if the MAC-RESOURCE PDU contains one of its own addresses or event labels, the MS-MAC shall then continue to process that new PDU.

The MS shall provide adequate buffering to store a fragmented TM-SDU which may be up to N.202 bits in length. The MS-MAC does not deliver any part of the TM-SDU to the LLC until the complete TM-SDU has been received.

#### 23.4.3.1.2 Reconstruction of uplink TM-SDU

On receipt of a MAC-ACCESS or MAC-DATA PDU, the BS shall perform the following actions relating to the TM-SDU.

If the received PDU does not indicate start of fragmentation then the BS shall assume that the received TM-SDU is complete.

If the received PDU indicates start of fragmentation, and if the BS decides to grant capacity for the fragmented message, then the BS shall store the TM-SDU fragment. It shall also monitor any subslot or slots granted to the MS for this address on this control channel (either granted already or granted in subsequent MAC-RESOURCE or MAC-END PDUs), looking for further fragments of the TM-SDU.

NOTE 1: The MS ISSI and its associated ASSI are equivalent for the purposes of usage of granted slots (so the MS will use any capacity granted on its ISSI for a fragmented message being sent with its ASSI, or vice versa). Similarly, an event label and its corresponding address are equivalent for the purposes of usage of granted slots. Also, a newly assigned ASSI is equivalent to the replaced ASSI or USSI for the purposes of usage of granted slots.

- a) If the MS requested a single subslot, and the BS grants a subslot for a final fragment, then the BS shall inspect the first PDU in that subslot.

If it receives the MAC-END-HU PDU, the BS shall append the TM-SDU fragment to the first fragment, and shall assume that the received TM-SDU is complete.

If it receives the MAC-ACCESS PDU, the BS shall discard the old fragment and shall continue to process the new PDU.

If it fails to decode the uplink subslot, the BS shall discard the old fragment.

- b) If the BS grants full slots to the MS, then it shall monitor those granted slots for the MAC-FRAG or MAC-END PDU.

On receipt of a MAC-FRAG PDU, the BS shall append the TM-SDU fragment to the already received fragment(s). It shall then continue to monitor the granted slots for further MAC-FRAG PDUs or for the MAC-END PDU.

On receipt of a MAC-END PDU, the BS shall append the TM-SDU fragment to the already received fragment(s), and shall assume that the received TM-SDU is complete.

NOTE 2: Occasionally the MAC-END PDU will contain no user data, in which case the already assembled fragments comprise the complete TM-SDU.

The BS may continue this process (granting more slots if appropriate) until it receives the MAC-END PDU, or until one of the following occurs:

- i) it receives a MAC-DATA PDU in one of the granted slots;
- ii) it fails to decode a MAC block in one of the granted slots;
- iii) it has not granted slots to the MS nor sent the instruction to "Wait for another Slot Grant", and a time T.202 has elapsed since the last slot granted to the MS on this control channel (see clause 23.4.2.1.2).

In all three cases, the BS shall discard the partially reconstructed TM-SDU. In case i), the BS shall continue to process the new PDU. In case ii), the BS shall discard any MAC-FRAG or MAC-END PDUs received in any further slots granted to this MS for this address (until receipt of the next MAC-ACCESS or MAC-DATA PDU from the MS).

If, at any time, the BS receives a MAC-FRAG, MAC-END or MAC-END-HU PDU in a granted slot or subslot, without a corresponding start of fragmentation from this MS (on this control channel), the BS shall discard the PDU.

NOTE 3: After receiving a fragmented TM-SDU containing a BL-DATA or BL-ADATA message, the BS may choose to send the LLC acknowledgement more than once (for reliability).

### 23.4.3.1.3 Reconstruction in minimum mode

#### a) Downlink TM-SDU

During minimum mode, the MS-MAC shall follow the defined minimum mode rules for receiving and decoding the downlink for signalling messages in frames 1 to 17 and in frame 18.

The normal procedure for reconstruction of a downlink TM-SDU, described in clause 23.4.3.1.1, generally applies except that, after the MS-MAC receives a MAC-RESOURCE PDU addressed to itself and containing a start of fragmentation, the procedure b) of clause 23.4.3.1.1 for looking for continuation fragments (MAC-FRAG) or for the end of the fragmented data (MAC-END) shall apply only to the MS's designated minimum mode frame 18 slot.

Also, the normal criteria ii) and iii) of clause 23.4.3.1.1 for discarding a partially reconstructed TM-SDU shall be replaced by the following criteria ii) and iii):

- ii) it fails to decode a SCH/HD or SCH/F MAC block in its designated minimum mode frame 18 slot;
- iii) it has received its designated minimum mode slot in N.203 consecutive frame 18s without receiving a fragment of its TM-SDU.

On leaving minimum mode, the MS-MAC shall return to the normal method of reconstruction (i.e. looking for fragments in all downlink slots on the MCCH).

NOTE 1: The above minimum mode procedure applies only to those MSs that are in common control mode and monitoring the MCCH. It does not apply to MSs on an assigned channel.

NOTE 2: While receiving a fragmented message during minimum mode, the MS-MAC is still required to receive slot 1 of frames 2 to 17, e.g. it may be sent a non-fragmented message. As defined in criterion i) of clause 23.4.3.1.1, the MS discards the partially reconstructed message if it receives any MAC-RESOURCE PDU on this channel containing "Length indication" = 11111<sub>2</sub> (i.e. start of fragmentation).

NOTE 3: The reconstruction procedure defined above applies only when the MAC-RESOURCE PDU was sent on SCH/F or SCH/HD (in slot 1 of frames 2 to 17 if the downlink is in FACCH or assigned SCCH, or in the MS's minimum mode frame 18 slot). If the MAC-RESOURCE PDU was sent on STCH then the reconstruction procedure defined in clause 23.4.3.1.7 applies.

#### b) Uplink TM-SDU

The normal procedure for reconstruction of an uplink TM-SDU, described in clause 23.4.3.1.2, applies during minimum mode.

### 23.4.3.1.4 Reconstruction on time-shared control channel

#### a) Downlink TM-SDU

On a time-shared MCCH, the MS-MAC shall follow the defined rules for receiving and decoding the downlink for signalling messages.

The normal procedure for reconstruction of a downlink TM-SDU, described in clause 23.4.3.1.1, generally applies except that, after the MS-MAC receives a MAC-RESOURCE PDU addressed to itself and containing a start of fragmentation, the procedure b) of clause 23.4.3.1.1 for looking for continuation fragments (MAC-FRAG) or for the end of the fragmented data (MAC-END) shall apply only to slot 1 of the reserved frames for this BS, not to the common frames.

Also, the normal criteria ii) and iii) of clause 23.4.3.1.1 for discarding a partially reconstructed TM-SDU shall be replaced by the following criteria ii) and iii):

- ii) it fails to decode a SCH/HD or SCH/F MAC block in slot 1 of one of the reserved frames for this BS;
- iii) it has received slot 1 of N.203 consecutive reserved frames for this BS without receiving a fragment of its TM-SDU.

NOTE: While receiving a fragmented message, the MS-MAC is still required to monitor slot 1 of the common frames, e.g. it may be sent a non-fragmented message.

For a time-shared common SCCH, "slot 1" in the above shall be replaced by the appropriate slot number on the main carrier.

**b) Uplink TM-SDU**

The normal procedure for reconstruction of an uplink TM-SDU applies.

**23.4.3.1.5 Reconstruction on assigned channel if downlink is in SACCH**

**a) Downlink TM-SDU**

In frames 1 to 17, reconstruction of downlink STCH may apply (see clause 23.4.3.1.7).

The normal procedure for reconstruction of a downlink TM-SDU, described in clause 23.4.3.1.1, generally applies for a message sent on the SACCH in frame 18 with the following differences:

- 1) If an MS that is transmitting traffic on the uplink receives a MAC-RESOURCE PDU in frame 18 of the assigned channel, individually addressed to itself and containing a start of fragmentation, the procedure b) of clause 23.4.3.1.1 for looking for continuation fragments (MAC-FRAG) or for the end of the fragmented data (MAC-END) shall apply only to the highest numbered downlink slot of the assigned channel in those frame 18s indicated by the assigned monitoring pattern(s).

Also, the normal criteria ii) and iii) of clause 23.4.3.1.1 for discarding a partially reconstructed TM-SDU shall be replaced by the following criteria ii) and iii):

- ii) it fails to decode a SCH/HD or SCH/F MAC block in the highest numbered downlink slot of the assigned channel in a frame 18 indicated by the assigned monitoring pattern(s);
- iii) it has received the highest numbered downlink slot of the assigned channel in N.203 consecutive frame 18s indicated by the assigned monitoring pattern(s) without receiving a fragment of its TM-SDU.

If the MS switches out of traffic transmit mode, it reverts to procedure 2). Or, if the downlink leaves SACCH, the MS reverts to the procedure for reconstruction when the downlink is in FACCH.

NOTE 1: For a single-slot channel, the highest numbered downlink slot of the assigned channel is implicitly the one slot of the assigned channel, as defined by element "timeslot assigned".

NOTE 2: For a simplex call, the transmitting MS recognizes that the downlink is in SACCH by using the AACH as defined in clause 23.5.6.3. For a duplex call, the duplex traffic transmit permission included traffic receive permission and thus indicated that the downlink is in SACCH.

NOTE 3: The reconstruction procedure defined above applies only for a message individually addressed to an MS that is transmitting traffic on the uplink. If the MS receives the start of a group addressed fragmented message then it should either discard the TM-SDU fragment or continue the reconstruction using procedure 2).

- 2) If an MS that is not transmitting traffic on the uplink receives a MAC-RESOURCE PDU in frame 18 of the assigned channel, addressed to itself and containing a start of fragmentation, the procedure b) of clause 23.4.3.1.1 for looking for continuation fragments (MAC-FRAG) or for the end of the fragmented data (MAC-END) shall apply only to the lowest numbered downlink slot of the assigned channel in frame 18.

Also, the normal criteria ii) and iii) of clause 23.4.3.1.1 for discarding a partially reconstructed TM-SDU shall be replaced by the following criteria ii) and iii):

- ii) it fails to decode a SCH/HD or SCH/F MAC block in the lowest numbered downlink slot of the assigned channel in frame 18;
- iii) it has received the lowest numbered downlink slot of the assigned channel in N.203 consecutive frame 18s without receiving a fragment of its TM-SDU.

If the MS switches into traffic transmit mode, it reverts to procedure 1). Or, if the downlink leaves SACCH, the MS reverts to the procedure for reconstruction when the downlink is in FACCH.

NOTE 4: Procedure 2) applies both to MSs receiving traffic on the channel in a simplex call and to any MSs not in traffic mode. The use of only the lowest numbered downlink slot in frame 18 for MAC-FRAG and MAC-END means that an MS receiving in traffic mode on a multi-slot channel is not required to modify its reception pattern during the reconstruction.

For a single-slot channel, the lowest numbered downlink slot of the assigned channel is implicitly the one slot of the assigned channel, as defined by element "timeslot assigned".

NOTE 5: If the MS is receiving traffic on the channel then the traffic receive permission informed it that the downlink is in SACCH. If the MS is not in traffic mode on the channel then it recognizes that the downlink is in SACCH (i.e. carrying traffic for other MSs) by using the AACH as defined in clause 23.5.6.3.

NOTE 6: In procedure 1), while receiving a fragmented message on SACCH, the MS-MAC also receives in frames 1 to 17 when appropriate. In procedure 2), while receiving a fragmented message on SACCH, the MS-MAC also receives in frames 1 to 17. In either case, the MS may be sent a non-fragmented message on STCH. And, as defined in criterion i) of clause 23.4.3.1.1, the MS discards the partially reconstructed message if it receives any MAC-RESOURCE PDU on this assigned channel containing "Length indication" =  $111111_2$  (i.e. start of fragmentation).

#### b) Uplink TM-SDU

If the uplink is in traffic then, in frames 1 to 17, reconstruction of uplink STCH may apply (see clause 23.4.3.1.7).

The normal procedure for reconstruction of an uplink TM-SDU, described in clause 23.4.3.1.2, applies on uplink SACCH or FACCH.

### 23.4.3.1.6 Reconstruction on assigned channel if downlink is in FACCH or assigned SCCH

#### a) Downlink TM-SDU

The normal procedure for reconstruction of a downlink TM-SDU, described in clause 23.4.3.1.1, generally applies when an assigned channel is not in downlink traffic with the following differences for an MS that is transmitting traffic on the uplink:

- If an MS that is transmitting traffic on the uplink receives a MAC-RESOURCE PDU individually addressed to itself and containing a start of fragmentation, the procedure b) of clause 23.4.3.1.1 for looking for continuation fragments (MAC-FRAG) or for the end of the fragmented data (MAC-END) shall apply only to those slots where the MS is required to look for further fragments (as defined below).

Also, the normal criteria ii) and iii) of clause 23.4.3.1.1 for discarding a partially reconstructed TM-SDU shall be replaced by the following criteria ii) and iii):

- ii) it fails to decode a SCH/HD or SCH/F MAC block in one of the slots where it is required to look for further fragments;
- iii) it has received N.203 consecutive slots where it is required to look for further fragments without receiving a fragment of its TM-SDU.

For a single-slot channel, the "slots where the MS is required to look for further fragments" (as used above) shall comprise the downlink slot, as defined by element "timeslot assigned", in those frames indicated by the assigned monitoring pattern(s).

For a frequency half duplex MS transmitting traffic on a multi-slot channel, the "slots where the MS is required to look for further fragments" (as used above) shall comprise:

- in frames 1 to 17: no slots; and
- in frame 18: the highest numbered downlink slot of the assigned channel, in those frame 18s indicated by the assigned monitoring pattern(s).

For a frequency full duplex MS transmitting traffic on a multi-slot channel, the "slots where the MS is required to look for further fragments" (as used above) shall comprise:

- in frames 1 to 17: all slots of the downlink assigned channel, as defined by element "timeslot assigned", in those frames indicated by the assigned monitoring pattern(s); and
- in frame 18: the highest numbered downlink slot of the assigned channel, in those frame 18s indicated by the assigned monitoring pattern(s).

NOTE 1: The reconstruction procedure defined above for a frequency half duplex MS transmitting traffic on a multi-slot channel applies even if the MS has fast switching capability.

NOTE 2: The reconstruction procedure defined above applies only for a message individually addressed to an MS that is transmitting traffic on the uplink. If the MS receives the start of a group addressed fragmented message then it should either discard the TM-SDU fragment or continue the reconstruction using the normal procedure defined in clause 23.4.3.1.1 (i.e. overriding the monitoring pattern information and assuming that continuation and final fragments may be transmitted on any downlink slot appropriate to the assigned channel).

NOTE 3: The normal reconstruction procedure defined in clause 23.4.3.1.1 applies for MSs that are not currently transmitting traffic on the uplink. So continuation and final fragments may be transmitted on any downlink slot appropriate to the assigned channel.

#### b) Uplink TM-SDU

If the uplink is in traffic then, in frames 1 to 17, reconstruction of uplink STCH may apply (see clause 23.4.3.1.7).

The normal procedure for reconstruction of an uplink TM-SDU, described in clause 23.4.3.1.2, applies on uplink SACCH or FACCH.

#### 23.4.3.1.7 Reconstruction on stealing channel

On the stealing channel STCH, fragmentation is only permitted within one timeslot. The procedure for reception of STCH (including reconstruction within the two half slots of one stolen timeslot) is described in clause 23.8.4.

#### 23.4.3.2 Fill bit deletion

On receipt of a TMA-SAP PDU, the MAC shall check whether fill bits are present ("fill bit indication" set to 1 in the PDU header). If fill bits are present, the MAC shall:

- inspect the last bit of the PDU;
- if the last bit is "1", remove this bit; then the rest of the data is the true PDU content;
- if the last bit is "0", remove this bit and all preceding zeros until a bit "1" is found; remove this bit "1"; then the rest of the data is the true PDU content.

The maximum number of fill bits to remove is normally 7 bits if a specific length indication is given in the MAC header. It may be a larger number if there is no length indication or if the length indication is set to 111110<sub>2</sub>.

Fill bits used for completing a MAC block after the Null PDU, or if there is not enough space for a Null PDU, shall be discarded.

The procedure for fill bit deletion is valid for both MS and BS.

#### 23.4.3.3 PDU dissociation

PDU dissociation shall be used when several small PDUs have been fitted into a single MAC block by the association procedure.

Each TMA-SAP PDU (except possibly the last in the MAC block) indicates the length of the PDU, as a number of octets. The MAC header of the next PDU immediately follows the end of the current PDU as indicated by the "length indication" element. So separation of PDUs from each other relies on the "length indication" contained in the first MAC header, then the second, and so on. The Null PDU indicates that there is no more useful data in this MAC block; after receipt of the Null PDU, the MAC shall not look for further information in the block. If the remaining size in the MAC block is less than the length of the Null PDU, the MAC shall discard the remaining bits.

This procedure is valid for both MS and BS.

In order to dissociate, the MAC shall:

- decode the first MAC header and extract the PDU length indication (if included); if there is no length indication for a TMA-SAP PDU, the PDU size shall be deemed to be the remainder of the MAC block; for a TMB-SAP PDU, the exact size of the PDU is implicit from the MAC header;
- remove any fill bits contained in the PDU, if indicated by the "fill bit indication";
- repeat the above steps until a Null PDU is found or the remaining space in the block is less than the size of the appropriate Null PDU.

Each separate PDU shall then be further processed by the MAC.

There will be some cases when the "Length indication" will indicate a value which exceeds the available capacity of the MAC block. The recipient MAC shall regard the length of the PDU as either the available capacity of the MAC block or the indicated length, whichever is the lesser. In either case, fill bits shall be removed if the "fill bit indication" is set to 1.

NOTE: The size of the appropriate Null PDU (as used above) is 16 bits for the downlink, 36 bits for an uplink subslot, or 37 bits for an uplink full slot or uplink STCH.

#### 23.4.3.4 PDU error detection

The purpose of the CRC added to a MAC block by the lower MAC is to enable the MAC at the receiving side of the air interface to detect whether errors have been introduced into the message during transmission. Therefore, the receiving lower MAC shall extract the decoded CRC and shall calculate a CRC on the remainder of the data as in the transmitting case. The two CRCs shall be compared. If they are not identical, the CRC fail parameter in the TMV-UNITDATA indication primitive shall inform the receiving upper MAC that an error has occurred.

Upon reception of a MAC block as indicated with the CRC fail parameter in the TMV-UNITDATA indication primitive, the upper MAC shall discard the incoming data. However, the upper MAC may use the CRC fail information to update its statistics on error measurement.

Upon reception of a MAC block as indicated with the CRC pass parameter in the TMV-UNITDATA indication primitive, the upper MAC shall further check that the incoming PDU or PDUs are valid by inspecting the headers.

### 23.4.4 Power control

#### 23.4.4.1 Overall process

Adaptive RF power control shall be used by the MS. It allows the system to minimize the transmit power required by the MS whilst maintaining the quality of the radio uplink. By minimizing the transmit power levels, interference to co-channel and adjacent channel users is reduced and MS power consumption could be reduced.

Two methods of adaptive RF power control may be used. The first method, known as open loop power control, shall be implemented in the MS. Using this method, the MS shall adjust its transmit power based on the power level or equivalent signal quality being received by the MS on the downlink from the BS. The second method, known as closed loop power control, shall be supported by the MS and may be implemented in the BS. Using this method, the MS shall adjust its transmit power as instructed by the BS. The BS shall calculate the optimal MS transmit power, for example based upon the power level being received on the uplink from that MS. The exact method of measurement and calculation in the BS are outside of the scope of the present document.

These methods are described in more detail in the following clauses. Adaptive RF power control shall not be used to control the BS transmit power.



### 23.4.4.2 MS open loop power control

Open loop power control shall be implemented in the MS. The power level shall be controlled for all transmitted bursts except random access messages for which power level control is optional. An MS, when camped on a cell, shall obtain the MS\_TXPWR\_MAX\_CELL and ACCESS\_PARAMETER parameters by decoding the SYSINFO PDU broadcast by the BS on the BNCH. For any reserved access or traffic transmissions, the MS shall use the transmit power level supported by the MS that is the closest to  $P_{MS}$ , where  $P_{MS}$  is defined by:

$$P_{MS} = \text{MIN} ( \text{MS\_TXPWR\_MAX\_CELL}, \text{ACCESS\_PARAMETER} - \text{RSSI} ) \quad (78)$$

where: MS\_TXPWR\_MAX\_CELL = Maximum MS transmit power allowed in the cell;

ACCESS\_PARAMETER = Parameter for transmit power calculation;

RSSI = Averaged signal level received by the MS or an equivalent signal quality measurement.

All values are expressed in dBm. The nominal MS power control level shall not exceed the maximum MS transmit power indicated in the MS\_TXPWR\_MAX\_CELL parameter.

NOTE: ACCESS\_PARAMETER is based on BS power and configuration and on the required mean power level received at the BS.

The MS, while receiving traffic or signalling, shall update  $P_{MS}$  for the current serving cell at least every 30 s and, in case of modification, may linearize on a subslot provided for common linearization (CLCH).

The MS, while transmitting, shall update  $P_{MS}$  at least every 3 s based upon its RSSI measurements. The MS shall adjust its transmit power to the level supported by the MS that is the closest to  $P_{MS}$ , at the latest, immediately following the next CLCH opportunity.

In the case of a random access transmission the MS may increase its nominal transmit power to a level supported by the MS that does not exceed the MS\_TXPWR\_MAX\_CELL parameter for this cell in order to increase the probability of the random access transmission reaching the BS without being corrupted.

### 23.4.4.3 MS closed loop power control

Closed loop power control may be employed by a BS in order to control the power of an MS transmitting in circuit mode on a traffic channel. The MS shall obey power control messages from the BS while the MS-MAC is transmitting in U-plane mode. Such power control instructions shall be obeyed only for the duration of that U-plane transmission after which the MS shall revert to open loop power control for subsequent transmissions.

When the MS-MAC switches from C-plane to U-plane transmission mode, or at any time during the U-plane transmission, the BS may control the MS transmit power by sending a MAC-RESOURCE PDU which includes the optional power control element, to instruct the MS to increase or decrease its transmit power by the appropriate number of steps (or remain at its current power level, see note 2). A step is equal to 5 dB except that, if an MS with a power class "L" is currently transmitting at its maximum transmit power, then the first step is 2,5 dB; see clause 6.4.1.2.

NOTE 1: The step size is always 5 dB for an MS that is not using a power class "L". It is also 5 dB for an MS with a power class "L" for steps other than the first step down from its maximum transmit power. The 2,5 dB first step for an MS with a power class "L" enables the MS to step down onto one of the power control levels defined in clause 6.4.1.2, table 4.

The MS shall obey these power control instructions. If the MS is instructed to increase its power above the maximum transmit power of that MS then it shall set its power to the maximum transmit power. Similarly, if it is instructed by the BS to set its power below the minimum power control level of 15 dBm, then it shall set its power to 15 dBm. The MS shall adjust its power after receiving a power control message, at the latest, immediately following the next CLCH opportunity. This power level shall take precedence over open loop power control and shall be used for all subsequent traffic and signalling transmissions, including any transmissions in frame 18, for the duration of the U-plane transmission until one of the following events occurs:

- a) the MS ends its transmission and switches out of U-plane mode; or
- b) the MS receives a MAC-RESOURCE PDU with the power control element set to "Revert to open loop power control".

Then the MS shall revert to using the rules defined for open loop power control as defined in clause 23.4.4.2. During closed loop power control operation, the MS shall continue to maintain its RSSI estimate for the downlink so that  $P_{MS}$  is always up to date.

NOTE 2: A power control message may instruct the MS to increase or decrease its transmit power. Alternatively, a power control element set to "No change in power" (value 0000<sub>2</sub>) instructs the MS to remain at its current power level, with that power level taking precedence over open loop power control until event a) or b) occurs.

### 23.4.5 MS linearization

The ACCESS-ASSIGN PDU shall indicate those uplink subslots that are available for common use for linearization. The MS may linearize its transmitter using any subslot that is indicated as a "CLCH subslot", without regard to the access code or common/assigned designation, and even on another physical channel.

In addition, during frame 18, the MS may linearize on the first subslot of the uplink slot defined by (in accordance with clause 9):

CLCH mapped if:

$$FN = 18 \text{ and } (MN + TN) \bmod 4 = 3 \quad (79)$$

This provides a linearization opportunity at least every four multiframe periods on each of the four physical channels of a carrier. The MS may linearize during these subslots without checking the AACH contents but the BS should set the AACH appropriately to indicate a CLCH opportunity.

If the BS is using discontinuous operation then the usage of this mapping is restricted as follows:

- if the BS is using carrier sharing then the MS may linearize using this mapping without checking the AACH contents only on an assigned channel or on a common control channel that it is receiving;
- if the BS is using MCCH sharing then the MS may linearize using this mapping without checking the AACH contents only on an assigned channel, or on a common control channel that it is receiving but restricted to those frame 18s that are reserved frames for this BS;
- if the BS is using traffic carrier sharing then the MS may linearize using this mapping without checking the AACH contents only on the main carrier or on an assigned channel.

The MS shall keep adequately linearized, so that it is ready at any time to send a message on the current uplink RF carrier (for example, a response to a BS paging message) without first needing to use a CLCH subslot. This rule shall apply even while the MS is in energy economy mode.

However, an exception is in the case of a dual watching MS which sometimes may not be able to maintain adequate V+D linearization during a Direct Mode call (see ETS 300 396-3 [35], clause 8.4.7.10). Then the MS may, if necessary, use the first subslot of an individually addressed slot grant for linearization. If it does this then it shall maintain adequate V+D linearization on that carrier for at least the next 4 multiframe periods in order to be able to send a message by reserved access if required.

NOTE: If the dual watching MS uses the first subslot of an individually addressed slot grant for linearization then, for a single-slot grant, it should not transmit in the second subslot of that slot; for a grant of more than one slot, it should not transmit in the second subslot of the first granted slot but then should send a V+D message in at least the second granted slot.

## 23.4.6 BS synchronization

When an MS moves from one carrier to another within a cell, it shall assume that the old frame and slot synchronization apply also on the new carrier. For example, at call set-up, it may immediately linearize and use granted slots or subslots using the timing of the old carrier.

Therefore, the BS shall synchronize the slot, frame and multiframe timing on all its carriers within a cell.

## 23.5 PDU transfer for signalling messages (TMA-SAP)

### 23.5.1 Random access protocol

#### 23.5.1.1 Introduction

The MS-MAC layer uses the random access protocol to initiate information transfer to the BS. The random access protocol is generally used for unsolicited MS messages, whereas messages solicited by the BS are sent using reserved access.

The random access protocol is based on slotted ALOHA procedures, with a superimposed access framing structure. By a suitable choice of access parameters, it is possible for the BS to:

- control the collision of access requests from different MSs;
- minimize access delay and traffic loss for a particular traffic loading;
- maintain peak throughput for a particular traffic loading;
- avoid protocol instability;
- dynamically restrict random access to different access priorities, and to selected groups and subscriber classes;
- provide simultaneously, independent access grades of service for different groups and subscriber classes.

The random access procedures defined in this clause are suitable for use on all types of control channel.

#### 23.5.1.2 Overview

This clause provides a general overview of the random access protocol. The precise protocol definition is contained in clauses 23.5.1.3 and 23.5.1.4.

The BS may offer random access opportunities to different sets of MSs in turn by using "Access Codes". There is a maximum of four possible access codes (desee noted A, B, C and D), and the BS marks each access opportunity with the appropriate access code.

The binding of MSs to access codes is dynamic. The binding defines the minimum valid priority for an access code. It may also restrict use of the access code to a set of subscriber classes, or to a group of MSs. An MS may use a subslot designated for a particular access code only if the PDU priority (as supplied by layer 3), and the subscriber class parameter or MS identity, conform to the current binding.

For a particular access code, requests from MSs are invited within "access frames" consisting of a number of access opportunities (uplink subslots).

The random access procedures are based on two types of PDU broadcast by the BS. The PDUs are:

i) The ACCESS-DEFINE PDU

This PDU is transmitted at intervals, how often being an operator option. It contains fairly slowly changing information about the random access parameters for an access code:

- the priority and MS binding to the access code;
- a parameter (IMM) defining when immediate access is permitted for the first transmission;
- the waiting time (WT) before deciding to re-try;
- the permitted number of random access retries;
- a frame-length multiplying factor;
- the uplink random access channel configuration.

ii) The ACCESS-ASSIGN PDU

This PDU is transmitted in every downlink slot on the AACH, in the broadcast block. It conveys information about the usage of the downlink slot in which it appears, and also access rights for the corresponding (same-numbered) uplink timeslot of that TDMA frame. When the uplink is in use for control signalling, the ACCESS-ASSIGN PDU usually contains two "Access Fields" which convey independent access rights for each of the two uplink subslots in the uplink slot.

The access field defines the allowed access code for the uplink subslot. It also may include a frame-length parameter. Otherwise, it may indicate that the uplink subslot is reserved for use by one MS and is therefore not available for random access; or it may assign the subslot for common linearization.

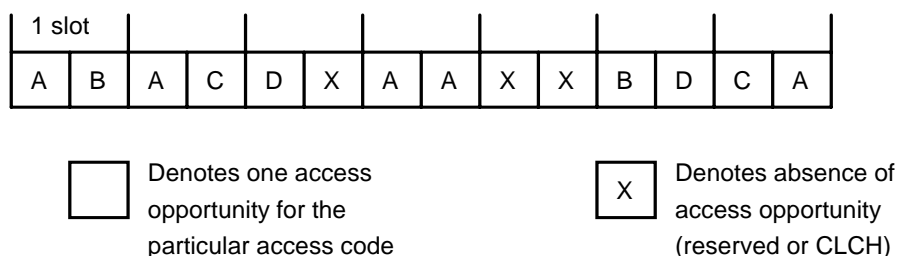
Also, the SYSINFO PDU (the content of BNCH) may include some default parameters to be assumed, for access code A, by MSs that have acquired the main carrier (until receipt of ACCESS-DEFINE PDUs). For BSs that do not need multiple access codes, the facilities provided by the SYSINFO PDU may be adequate, so that the ACCESS-DEFINE PDU is not used.

The BS may optimize the system performance by varying the access code bindings, the frame-length and the other access parameters. The choice of parameters will depend on the type of system and the traffic mix.

The basic format of the random access channel is illustrated in figures 143 to 145 inclusive.

NOTE: In these representations, the detailed TDMA frame structure (e.g. with a control timeslot and three traffic timeslots per TDMA frame) is not shown. The uplink control subslots (half timeslots) for this control channel are shown as if they were contiguous.

Figure 143 illustrates an example of designation of uplink subslots, showing multiple access codes and reserved subslots. The designation is performed using the AACH, with one ACCESS-ASSIGN PDU defining the use of the two corresponding uplink subslots.



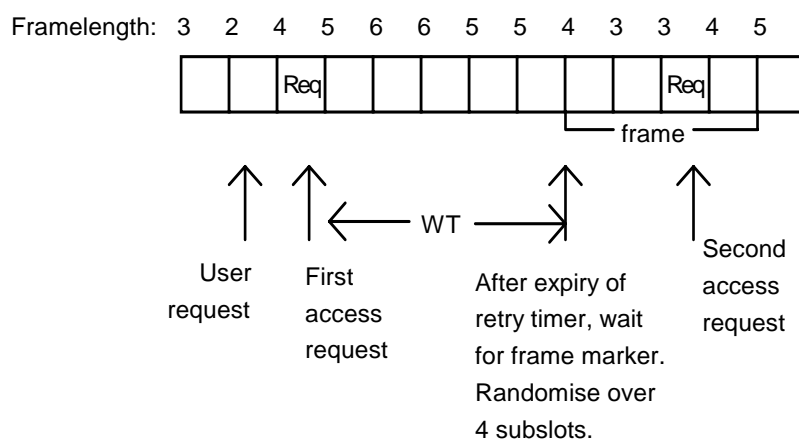
**Figure 143: Example of subslot structure**

Now consider only those subslots relevant to a particular access code. For these subslots, requests from MSs are invited within access frames. The access field in the ACCESS-ASSIGN PDU indicates the number of following uplink subslots, for this access code, that constitute an access frame. A special value ("ongoing frame") is used when the field does not mark the start of a new access frame.

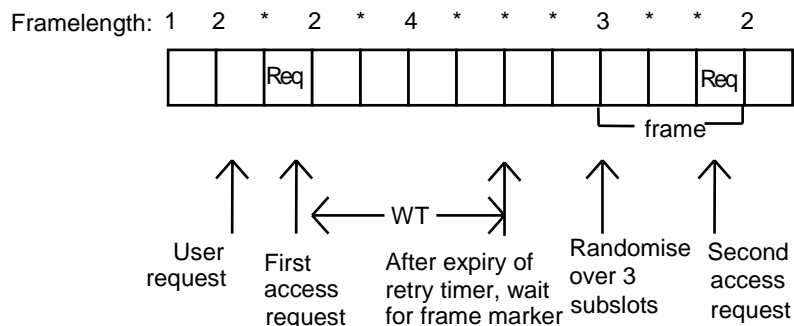
When a user request is initiated, for example valid for access code A, the MS-MAC is permitted to send a first random access request in the next access code A subslot, provided that this occurs within a designated time. Otherwise the MS-MAC waits for an ACCESS-ASSIGN PDU containing a frame marker for access code A, and then chooses a subslot randomly from this access frame for its random access request. An MS-MAC wishing to send a repeat transmission after an unsuccessful access request waits for a new frame marker before choosing another subslot randomly from that frame.

This procedure is illustrated in figures 144 and 145, in which the subslots shown are only those control subslots marked for random access by access code A. WT is the re-try time when the MS-MAC decides that its access request has failed.

In figure 144, the BS chooses to mark rolling access frames, with a new access frame marked in every subslot so that the access frames clearly overlap. In figure 145, the BS chooses to mark discrete access frames, by using the "ongoing frame" value (here desec noted by \*) to indicate continuation. The MS procedures operate independently of this BS choice.



**Figure 144: Example of random access procedure (BS using rolling access frames)**



**Figure 145: Example of random access procedure (BS using discrete access frames)**

In either case, the BS may monitor activity on the uplink channel in the subslots assigned to the access code, and may vary the frame-length to prevent excessive collision and to minimize access delays. Under normal conditions, the frame-length can be short. Then, when collision is detected, the BS may increase the frame-length dynamically according to its estimate of the backlogged traffic. This allows rapid smoothing of traffic transients.

### 23.5.1.3 Access control facilities for BS

See also the MS random access protocol (clause 23.5.1.4).

### 23.5.1.3.1 Transmission of ACCESS-DEFINE and ACCESS-ASSIGN PDU

The BS may transmit ACCESS-DEFINE PDUs at intervals decided by the operator, and shall transmit the ACCESS-ASSIGN PDU in every downlink timeslot. The formats of these PDUs are defined in clause 21. Between them, these PDUs shall indicate:

- the configuration of the random access channel for this control channel;
- the valid priorities and the MSs eligible for each uplink subslot;
- the frame-lengths to be used; and
- other ALOHA re-try parameters.

Also, the BS may include in the SYSINFO PDU some default random access parameters to be assumed by MSs, for access code A, until receipt of ACCESS-DEFINE PDUs.

The following points may be seen noted:

- a) MSs that have missed ACCESS-DEFINE PDU broadcasts will be unaware of some of the current access restrictions and will be applying the limitations of the last received ACCESS-DEFINE PDU (or SYSINFO information);
- b) MSs count subslots in access frames using only the ACCESS-ASSIGN PDUs that they receive. Therefore, in case of un-decodeable ACCESS-ASSIGN PDUs, not all MSs will count the subslots in exactly the same way;
- c) Use of the ACCESS-DEFINE PDU is not required if the facilities provided within the SYSINFO PDU are adequate for a particular BS;
- d) The "Timeslot Pointer" element in the ACCESS-DEFINE PDU (and SYSINFO) allows the BS to define those timeslots per TDMA frame that can be used for random access by MSs on this control channel, independently of the downlink channel configuration. For example, the BS may define an extended random access channel, allowing additional random access opportunities. The BS may define an extended random access channel for a common control channel (i.e. MCCH or common SCCH) or for an assigned channel;

The ACCESS-ASSIGN PDU then indicates (on a slot-by-slot basis) whether each uplink random access slot is available for common use or only for MSs on an assigned channel. This allows flexible use of the uplink e.g. in the case of an extended random access channel or in the case of minimum mode;

- e) The BS designer should see note the default assumptions for an MS when it acquires the main carrier or changes channel within the cell.

### 23.5.1.3.2 BS response to access request

After receiving an MS random access request, the BS should respond with a MAC-RESOURCE PDU indicating successful random access. The response may be sent in the corresponding downlink timeslot in the next TDMA frame (if that slot is appropriate to the downlink control channel). Alternatively the response may be delayed. The WT parameter in the ACCESS-DEFINE PDU defines the time the MS-MAC will wait before deciding to retransmit; see clause 23.5.1.4.

The BS should return the response in a timeslot on the MS's downlink control channel. In the case of a multi-slot downlink control channel, the BS may return the response in any slot of that downlink control channel.

If there is any possible ambiguity about the requesting MS's downlink configuration, the BS may return the response in more than one downlink slot.

If the BS is ready to return an LLC response or a layer 3 message (e.g. D-CALL PROCEEDING or D-CONNECT ACKNOWLEDGE) to the requesting MS at the time when it sends the MAC-RESOURCE response PDU, then it may carry a TM-SDU in the MAC-RESOURCE PDU. Otherwise it should send a dedicated MAC response PDU.

### 23.5.1.3.3 Reserving subslots on uplink

During an access frame, the BS may transmit PDUs that demand a response from a specific MS (e.g. the D-SETUP PDU). To allow the MS to respond without making a random access, the BS may reserve a subslot or slot(s) for the response. The ACCESS-ASSIGN PDU shall indicate which subslots are reserved and therefore not available for random access. The MS for which a subslot or slot(s) are reserved shall be informed in the downlink signalling channel (see clause 23.5.2).

The ACCESS-ASSIGN PDU shall also indicate subslots that are available for common use for linearization (and therefore not available for random access).

### 23.5.1.4 MS-MAC random access protocol

The general random access procedure is described in clauses 23.5.1.4.1 to 23.5.1.4.9; this procedure covers normal operation on one control channel (common, assigned or multi-slot). Then any variations in operation for different channel configurations are described in clauses 23.5.1.4.10 to 23.5.1.4.14.

#### 23.5.1.4.1 Reception of ACCESS-DEFINE PDU

The MS-MAC shall continuously receive the downlink control channel, looking for ACCESS-DEFINE PDUs (within the constraints of the energy economy or dual watch regime and the cell reselection procedures, and linearization and transmission requirements). The downlink slot(s) appropriate to this control channel are known from the SYSINFO PDU (BNCH) or from the "Timeslot Assigned" element in the MAC-RESOURCE or MAC-END PDU that sent the MS to the channel. An ACCESS-DEFINE PDU defines access restrictions and access parameters for one access code.

On receipt of an ACCESS-DEFINE PDU, the MS-MAC shall see note the minimum valid priority for the access code; also, if included, the MS-MAC shall see note the eligible subscriber classes or group address. If the ACCESS-DEFINE PDU does not include a "subscriber class bit map" element, the MS-MAC shall assume that there is no subscriber class restriction. If the ACCESS-DEFINE PDU does not include a "GSSI" element, the MS-MAC shall assume that there is no address restriction.

The MS-MAC shall see note the ALOHA parameters (IMM, WT, Nu, frame-length factor). It shall also see note from element "Timeslot Pointer" which uplink slots are potentially available for random access on this control channel i.e. the valid pattern for monitoring the AACH for access invitations. If Nu is set to 0 in the ACCESS-DEFINE PDU, this indicates that the access code is not available for use.

The MS-MAC shall comply with the received ACCESS-DEFINE parameters for random access attempts on this access code and control channel. Each parameter set shall remain valid until updated by a subsequent ACCESS-DEFINE PDU for this access code and with the same setting of the "Common or assigned control channel flag", received on this downlink control channel.

NOTE 1: A subsequent ACCESS-DEFINE PDU for this access code overwrites the previous definition even if the addressing mechanism (i.e. subscriber class bit map, GSSI or neither) is not the same.

An MS on the MCCH or on a common SCCH shall ignore any received ACCESS-DEFINE PDUs containing "Common or assigned control channel flag" = 1 (i.e. assigned). Similarly, an MS on a channel assigned for SCCH or for a circuit mode call shall ignore any received ACCESS-DEFINE PDUs containing "Common or assigned control channel flag" = 0 (i.e. common).

NOTE 2: The "Timeslot Pointer" element may give a bit map of the appropriate timeslots for the random access channel for this control channel, or it may be set to 0000<sub>2</sub> (i.e. same as downlink slot assignment). The latter means:

- slot 1 if the MS is on the MCCH;
- the appropriate slot for this MS when common SCCHs are in use; or
- the same timeslot number(s) as for the "Timeslot Assigned" element from the MAC-RESOURCE or MAC-END PDU in the case of an assigned channel.

### 23.5.1.4.2 Reception of ACCESS-ASSIGN PDU

If the MS-MAC wishes to send a random access message, and knows a valid access code for the message, it shall attempt to decode the appropriate downlink AACH which contains the ACCESS-ASSIGN PDU. The MS should look for AACH in all the slots defined by element "Timeslot Pointer" from the ACCESS-DEFINE PDU (or the default value from the SYSINFO PDU), in all frames 1 to 18.

If an ACCESS-ASSIGN PDU contains two access field elements then "Access Field 1" conveys access rights to subslot 1 in the corresponding uplink slot, i.e. the same-numbered uplink timeslot of that TDMA frame. "Access Field 2" conveys independent access rights to subslot 2 in the uplink slot.

If an ACCESS-ASSIGN PDU contains only one access field, this conveys access rights to both subslots of the corresponding uplink slot as follows:

- a) the same access code shall be assumed for both subslots;
- b) when the access field indicates "Reserved Subslot", it shall be assumed that both subslots are reserved;
- c) when the access field indicates "CLCH Subslot", it shall be assumed that subslot 1 may be used for linearization, and subslot 2 is reserved;
- d) when the access field indicates "Ongoing Frame", it shall be assumed that ongoing frame applies to both subslots;
- e) when the access field indicates a frame marker base frame-length of  $\geq 1$  subslots, it shall be assumed that the frame marker base frame-length applies to subslot 1, and that "Ongoing Frame" applies to subslot 2.

If an ACCESS-ASSIGN PDU contains no access field (i.e. traffic on uplink) then both the corresponding uplink subslots shall be regarded as reserved.

If an MS on the MCCH or on a common SCCH receives an ACCESS-ASSIGN PDU indicating that the uplink slot is designated as "Assigned only", then both the corresponding uplink subslots shall be regarded as reserved.

If an MS on an assigned channel (assigned for SCCH or for a circuit mode call) receives an ACCESS-ASSIGN PDU indicating that the uplink slot is designated as "Common only", then both the corresponding uplink subslots shall be regarded as reserved.

If an ACCESS-ASSIGN PDU is un-decodeable then both the corresponding uplink subslots shall be regarded as reserved.

**NOTE:** As defined in clause 9, the start of the TDMA frame (and multiframe and hyperframe) on the uplink is delayed by a fixed period of two timeslots from the start of the TDMA frame (or multiframe or hyperframe) on the downlink. So the ACCESS-ASSIGN PDU in a downlink slot conveys access rights to the corresponding uplink slot, which is two slots later.

### 23.5.1.4.3 Initiating a random access

The MS shall only make one random access attempt at a time, per control channel. A random access attempt refers to the period from initiation of the random access procedure until a response is received or the procedure is abandoned.

When the MS has individually addressed signalling messages to send, as indicated by the DATA-IN-BUFFER signal from the LLC, the MS-MAC may initiate the random access procedure if it:

- a) does not have a reserved subslot or slot(s) already granted for this address on this control channel; and
- b) has not already indicated to the BS that it has a signalling requirement for this address on this control channel (by asking for a reserved subslot or slot(s)).

**NOTE 1:** The ISSI and its associated ASSI are equivalent for the purposes of the slot granting procedure (so the MS should use any subslot or slot(s) granted on its ISSI for messages sent with its ASSI, or vice versa). Similarly, an event label and its corresponding address are equivalent for the purposes of the slot granting procedure. Also, a newly assigned ASSI is equivalent to the replaced ASSI or USSI for the purposes of the slot granting procedure.



Also, the MS-MAC may initiate the random access procedure if it does not have a reserved subslot or slot(s) already granted for this address, and the LLC indicates that a new emergency message has just been received from layer 3, as indicated by the priority parameter in the DATA-IN-BUFFER signal.

NOTE 2: This exception allows the MS-MAC to cut short the reserved access waiting time-out T.206 in case of emergency; see clause 23.5.2.4. The MS may then send the emergency message by random access.

If the MS-MAC was in the process of sending a fragmented message at the time when it decides to cut short the reserved access waiting time-out T.206, it should discard the partially sent TM-SDU.

The random access request shall be sent using the MAC-ACCESS PDU, fitting within a single subslot on the uplink (SCH/HU) and containing a TM-SDU or first fragment if appropriate. Any TM-SDU to be sent, or TM-SDUs if using association, are received from the LLC in the TMA-UNITDATA request primitive.

If the MS has any further signalling to send for this address on this control channel, the MS-MAC shall include a request for reserved capacity in the MAC-ACCESS PDU.

When the MS-MAC is required to initiate a random access, it shall comply with the access parameters. If the access request is not valid for any of the current access codes (as specified in clauses 23.5.1.4.1 and 23.5.1.4.4), the MS-MAC may immediately abandon the random access attempt, reporting the failure to the LLC using the TMA-REPORT indication primitive.

#### 23.5.1.4.4 Checking for appropriate access code

When the MS-MAC wishes to send a non-emergency message, it shall not use a subslot designated for a particular access code unless the following criteria are all satisfied:

- a) the PDU priority, as supplied in the TMA-UNITDATA request primitive, is equal to or higher than the minimum priority for this access code;
- b) if subscriber class is restricted for this access code: the subscriber class information, as supplied in the TMA-UNITDATA request primitive, is eligible for this access code;
- c) if address is restricted for this access code: the designated GSSI is one of the MS's valid group addresses.

For an emergency message, the same criteria shall apply for access codes B, C and D. However, the MS may use access code A for an emergency message without checking the above criteria.

For a message sent when the MS does not yet have subscriber class information for this network, criterion b) need not be checked.

NOTE 1: In criterion b), the eligibility for subscriber class requires that, for at least one class, the class is invited by the ACCESS-DEFINE PDU (i.e. there is a "1" in the appropriate position) and the MS belongs to that class.

NOTE 2: The message is an "emergency message" if the PDU priority parameter in the TMA-UNITDATA request indicated the highest priority, i.e. 7.

NOTE 3: The exemption from checking criterion b) when the MS does not yet have subscriber class information for this network applies during migration. It applies also if the MS has not yet registered and did not receive subscriber class information at subscription.

#### 23.5.1.4.5 First try procedure

There is a special procedure for the first random access transmission.

The MS-MAC shall transmit its random access request in the first uplink slot in which one or both subslots are valid access opportunities (i.e. slot corresponds to element "Timeslot Pointer" and has an appropriate common/assigned designation, and subslot has an appropriate access code and is not reserved nor assigned for linearization) if:

- a) it is an emergency message; or
- b) parameter IMM = 15; or
- c)  $1 \leq \text{IMM} \leq 14$ , and the valid access opportunity occurs within the IMM TDMA frames following the initiation of the random access procedure.

If both the subslots in the uplink slot are valid access opportunities, the MS-MAC shall choose one of the two subslots randomly. This rule applies only to this first try procedure.

If the above conditions are not met, then the MS-MAC shall choose a subslot from a new access frame (see clause 23.5.1.4.6).

If a complete TM-SDU is contained within the MAC-ACCESS PDU, then the MS-MAC shall report to the LLC when the first random access transmission has been sent using the TMA-REPORT indication primitive.

#### 23.5.1.4.6 Choosing from a new access frame

An MS-MAC that requires to select a subslot from a new access frame shall wait for a suitable access frame marker i.e. an ACCESS-ASSIGN PDU in a slot corresponding to element "Timeslot Pointer" with an access field that contains:

- a frame marker ("Base Frame-length" of  $\geq 1$  subslots); and
- an appropriate uplink slot designation (common/assigned); and
- an appropriate access code (as defined in clause 23.5.1.4.4),

with the most recently received access code parameters enforced at this time.

The MS-MAC shall then select a subslot randomly from the specified access frame. That is, it shall choose a subslot randomly between 1 and "Frame-length" using a uniform distribution, where:

```
if the "frame-length factor" for this access code = 0
then Frame-length = 1 * Base Frame-length
else Frame-length = 4 * Base Frame-length.
```

The MS-MAC shall transmit its access request in the chosen subslot, unless the random access attempt is abandoned (see clause 23.5.1.4.9).

#### 23.5.1.4.7 Counting subslots in an access frame

The uplink subslot corresponding to the frame marker access field is defined as the first subslot in the access frame.

When counting further access subslots to its chosen subslot in the access frame, the MS-MAC shall count a subslot only if:

- a) it was indicated by element "Timeslot Pointer" in the ACCESS-DEFINE PDU (or, for access code A, in the SYSINFO PDU if the default definition is still valid); and
- b) the corresponding ACCESS-ASSIGN PDU is decodeable; and
- c) the uplink slot designation (common/assigned) is appropriate for this control channel; and
- d) the subslot is marked with the appropriate access code, i.e. the access code used when choosing from the access frame; and
- e) the subslot is not designated as reserved or assigned for linearization.

NOTE: Subslots for this code designated as "ongoing frame" are counted, and also subslots starting new access frames; a new access frame marker does not alter a subslot choice already made.

#### 23.5.1.4.8 Re-try procedure

After sending an access request, the MS-MAC shall wait for a response from the BS, i.e. a MAC-RESOURCE PDU on the downlink control channel, containing the same address as in the access request and with the "random access flag" indicating successful random access. If a complete TM-SDU was contained within the MAC-ACCESS PDU, the MS-MAC shall report the success to the LLC using the TMA-REPORT indication primitive. Then, if the received MAC-RESOURCE PDU contains a TM-SDU, the MS-MAC shall deliver that TM-SDU to the LLC using the TMA-UNITDATA indication primitive.

The MS-MAC shall look for the response in all downlink slots appropriate to this downlink control channel, as indicated by the SYSINFO PDU or by the MAC-RESOURCE or MAC-END PDU that sent the MS to the channel. The first potential slot in which the response may be received is the corresponding downlink slot in the next TDMA frame, i.e. the same timeslot number as the request slot, if that slot is appropriate to the downlink control channel. This allows the MS one timeslot duration for switching from transmission to reception.

If a response is not received within the WT downlink signalling opportunities after transmission of its access request, the MS-MAC shall assume that the transmission has failed. Then it shall either:

- a) abandon its random access attempt (see clause 23.5.1.4.9 point a); or
- b) select a further subslot randomly from a new access frame, as in clause 23.5.1.4.6, and using a frame marker ACCESS-ASSIGN PDU received in or after the WT<sup>th</sup> downlink signalling opportunity following the unsuccessful access request. However, if the MS-MAC receives a response before sending a repeat message, it shall accept the response and not retransmit.

When counting slots (i.e. downlink signalling opportunities) for time-out WT, the MS-MAC shall count only one slot per TDMA frame, namely the downlink slot with the same timeslot number as the request slot or, if that slot is not appropriate to the downlink control channel, then the next slot that is appropriate to the downlink control channel.

On an assigned channel, the MS-MAC shall count the downlink slot only if it is available for control. Downlink slots in frames 1 to 17 for which the AACH (or last received AACH in frames 1 to 17) indicates downlink user traffic should not be counted in the time-out WT. However, the BS may choose to send the response by stealing from the downlink TCH.

NOTE 1: Downlink user traffic in frames 1 to 17 is indicated by Header  $\neq 00_2$  and downlink usage marker  $\geq 000100_2$ .

NOTE 2: The above procedure allows for possible cases of independent allocation of uplink and downlink.

NOTE 3: As defined above, the MS looks for a response in all downlink slots appropriate to that channel. However a maximum of one slot per TDMA frame is counted for time-out WT. This is equivalent to the method for timers T.202 and T.206, and some LLC timers. It contrasts with the method for counting uplink opportunities for the granting delay for reserved access, when all slots on a multi-slot channel are counted; and with the method for counting access subslots in an access frame, when all appropriate subslots are counted.

#### 23.5.1.4.9 Abandoning random access attempt

The MS-MAC shall cease attempting random access if it receives a response from the BS, as described in clause 23.5.1.4.8, or if any of the following occurs:

- a) The MS-MAC has sent the current maximum permitted number of random access transmissions without receiving a response; the maximum number of transmissions is  $N_u$  for a message with PDU priority 0 to 6, or  $2 \times N_u$  for a message with PDU priority 7. The failure shall be reported to the LLC using the TMA-REPORT indication primitive.
- b) A time  $T_{.205}$  has elapsed since initiation of the random access procedure. The failure shall be reported to the LLC.
- c) The MS-MAC receives a TMA-CANCEL request primitive from the LLC, cancelling transmission of this message. The MS-MAC shall abandon the random access attempt whether or not it has sent any transmissions, reporting the state of transmission to the LLC.
- d) The MS-MAC receives a MAC-RESOURCE (or MAC-END) PDU that does not indicate successful random access but grants a reserved subslot or slot(s) for this address. The MS-MAC shall send a PDU (or PDUs) in the reserved capacity, i.e. its own request and/or the message demanded by the BS. If the MS has any further signalling ready to send for this address on this control channel, the MS-MAC shall include the "reservation requirement" element in its transmission.

If a complete TM-SDU is transmitted, the MS-MAC shall report to the LLC that the message has been sent by reserved access.

Also, if the access request becomes ineligible for the current definition of the access codes, the MS-MAC may abandon the random access attempt, reporting the failure to the LLC.

If the MS-MAC abandons a random access attempt without having received a response from the BS, it shall not initiate any new random access attempt until any ongoing WT timer from the last request has expired.

#### 23.5.1.4.10 Random access operation after acquiring main carrier

The MS-MAC shall make the following assumptions about the random access parameters on first acquiring a main carrier or receiving a channel allocation for a new cell.

If the MS-MAC has received the "default definition for access code A" element in the SYSINFO PDU then it shall assume the most recently received SYSINFO parameters for access code A, and with no MAC subscriber class restriction or address restriction, until it receives an ACCESS-DEFINE PDU for access code A. Otherwise it shall not use access code A until it receives either the SYSINFO default definition for access code A or an ACCESS-DEFINE PDU for access code A.

The MS-MAC shall not use access code B, C or D until it receives the appropriate ACCESS-DEFINE PDU.

NOTE 1: These parameters apply both to the MCCH and to a common SCCH.

There is no time limit on the validity of use of the SYSINFO parameters, since some BSs may choose never to send the ACCESS-DEFINE PDU, relying solely on the SYSINFO default definition for access code A. Until receipt of a "common" ACCESS-DEFINE PDU for access code A, the MS shall assume the most recently received SYSINFO parameters. After receipt of a "common" ACCESS-DEFINE PDU for access code A, the MS shall ignore any access parameters received in SYSINFO PDUs, reverting to the procedure in clause 23.5.1.4.1.

NOTE 2: The validity of use of the SYSINFO parameters on the MCCH or a common SCCH is not affected by receipt of an ACCESS-DEFINE PDU with "Common or assigned control channel flag" = 1 (i.e. assigned). Receipt of an "assigned" ACCESS-DEFINE PDU for access code A while the MS is on the MCCH or a common SCCH does not affect the validity of the SYSINFO parameters. Receipt of an "assigned" ACCESS-DEFINE PDU for access code A while the MS is on an assigned channel over-rides the SYSINFO definition while the MS is on that assigned channel, but does not affect operation when the MS returns to the MCCH or to a common SCCH.

#### 23.5.1.4.11 Random access operation on a new channel

When an MS is sent to a new channel within the cell, it shall make the following assumptions about the random access parameters, until updated by ACCESS-DEFINE PDUs or the SYSINFO definition.

- a) When changing channel to the MCCH or to a common SCCH, the MS-MAC shall assume that all random access parameters except the "Timeslot Pointer" are equal to those used when the MS-MAC last received either the MCCH or a common SCCH (parameters as received in SYSINFO and/or ACCESS-DEFINE PDUs). This rule applies both when the BS has changed the number of common SCCHs in use and when the MS-MAC returns from an assigned channel.

The MS-MAC shall assume that the random access channel uses the same timeslot as the current downlink assignment.

- b) For an assigned channel (either for SCCH or for a circuit mode call):
- For the "Timeslot Pointer", the MS-MAC shall assume the same timeslot number(s) as for the "Timeslot Assigned" from the MAC-RESOURCE or MAC-END PDU;
  - The MS-MAC shall assume that the other parameters are equal to those on the old channel except that, for access code A, the MS-MAC shall assume "Frame-length Factor" = 0, "Minimum Priority" = 000<sub>2</sub> and no subscriber class restriction or address restriction.

The MS-MAC may continue an ongoing random access attempt on the new channel, but shall choose a subslot from a new access frame using an appropriate frame marker received on the new channel.

The random access parameters shall all be updated on receipt of an appropriate ACCESS-DEFINE PDU on that channel. If the MS is on the MCCH or a common SCCH, and is still using the SYSINFO default definition, then the MS shall update the parameters on receipt of a new SYSINFO definition on that channel. If the MS is on an assigned channel, and is still using the SYSINFO default definition on that channel, then the MS shall update the parameters on receipt of a new SYSINFO definition on that channel, except for parameters "Timeslot Pointer", "Frame-length Factor" and "Minimum Priority" for which it shall retain the values given in b) above.

#### 23.5.1.4.12 Random access operation on ACCH

If the MS-MAC wishes to send a random access message on a channel allocated for a circuit mode call, it shall obey the normal procedures but with the following differences.

If the MS is transmitting traffic in frames 1 to 17 and sends a random access request in frame 18 then, when counting downlink slots for waiting time WT, the MS shall count only those slots that it is required to monitor, according to the assigned monitoring pattern(s), and are available for control (see clause 23.5.1.4.8).

NOTE 1: As in clause 23.5.1.4.8, the MS counts a maximum of one slot per TDMA frame for waiting time WT.

NOTE 2: For a multi-slot channel, if the MS is not frequency full duplex, and if the BS assigns monitoring pattern(s) that the MS is not capable of following, then, when counting for waiting time WT, the MS counts only those downlink frames containing at least one slot that it is able to monitor and that is available for control.

For a multi-slot channel, if the MS is not frequency full duplex, and if there is currently traffic on the downlink, then the MS is not required to transmit a random access request if it would thereby miss downlink traffic. The MS may regard unsuitable uplink subslots as reserved.

Similarly, for a multi-slot channel, if the MS is not frequency full duplex, and if the MS is currently performing a reconstruction of a downlink TM-SDU, then the MS is not required to transmit a random access request if it would thereby cause the reconstruction to fail. The MS may regard unsuitable uplink subslots as reserved. This applies for any multi-slot assigned channel i.e. assigned either for SCCH or for a circuit mode call.

#### 23.5.1.4.13 Random access operation in minimum mode

During minimum mode, the MS-MAC shall follow the defined minimum mode rules for monitoring and decoding the downlink for signalling messages - in slot 1 of frames 1 to 17 and in its designated minimum mode slot in frame 18.

When an MS-MAC enters minimum mode, the most recently received access definitions shall apply. If the MS-MAC then receives ACCESS-DEFINE PDUs in the downlink slots that it is required to monitor, it shall obey the ACCESS-DEFINE definition for PDUs containing "Common or assigned control channel flag" = 0 (i.e. common); but shall ignore ACCESS-DEFINE PDUs containing "Common or assigned control channel flag" = 1 (i.e. assigned).

If an MS-MAC in minimum mode wishes to send a random access message, the valid pattern for monitoring the AACH for access invitations and for counting subslots in an access frame is:

- in frames 1 to 17: the slot(s) defined by the current setting of "timeslot pointer";
- in frame 18: all four slots.

Only those uplink slots marked in the ACCESS-ASSIGN PDU as available for common access are applicable.

The procedures defined in preceding clauses for choosing a subslot for the first and subsequent random access transmissions shall apply. When counting downlink slots for waiting time WT, the MS shall count only its designated minimum mode frame 18 slot. However, the BS may choose to send the response in slot 1 of the assigned channel during frames 2 to 17, either by stealing or within the assigned channel's FACCH (as described in clause 23.3).

NOTE: The above minimum mode procedure applies only to those MSs that are in common control mode and monitoring the MCCH. It does not apply to MSs on an assigned channel.

#### 23.5.1.4.14 Random access operation on time-shared control channel

On a time-shared MCCH, the MS-MAC shall follow the defined rules for monitoring and decoding the downlink for signalling messages.

If the MS-MAC wishes to send a random access message, it shall obey the normal procedures but with the following differences:

- The rules for monitoring the downlink for the ACCESS-ASSIGN PDU (according to element "Timeslot Pointer") shall apply only to the frames reserved for this BS and the common frames.

- For  $1 \leq IMM \leq 14$ , IMM shall be replaced by:

$$IMM \times 12 / TS-RES, \text{ for } TS-RES = 1, 2, 3, 4, 6;$$

$$IMM \times 36 / TS-RES, \text{ for } TS-RES = 9, 12, 18;$$

where TS-RES is the number of reserved frames per two multiframes for this BS.

- When counting downlink slots for waiting time WT, the MS shall count only slot 1 of the frames reserved for this BS. However, the BS may choose to send the response in slot 1 of one of the common frames.

For a time-shared common SCCH, "slot 1" in the above shall be replaced by the appropriate slot number on the main carrier.

#### 23.5.1.4.15 Random access operation on CSS channel

On a CSS channel, the MS-MAC shall generally apply the random access procedures defined in the earlier clauses within clause 23.5.1.4 as if the CSS channel were an independent single-slot assigned channel allocated by a specific MAC-RESOURCE or MAC-END PDU with "Timeslot Assigned" =  $1000_2$  (see clause 23.5.4.2.1 d)). So, for example:

- a) The ALOHA parameters (e.g. IMM, WT, Nu, frame-length factor) received on the CSS downlink channel apply to the CSS random access channel.
- b) An uplink slot has an appropriate common/assigned designation only if it is designated as "common and assigned" or "assigned only".

However, the following differences shall apply:

- 1) As defined in clause 23.5.4.2.1 d), the MS is only required to receive the CSS channel within the capabilities of that MS.
- 2) If the MS is not frequency full duplex then it is not required to transmit a random access request on the CSS channel if it would thereby miss downlink traffic on an assigned channel or cause a reconstruction on an assigned channel to fail. The MS may regard unsuitable uplink subslots on the CSS channel as reserved.
- 3) After sending a random access request on the CSS channel and not receiving a response within the waiting time WT, the MS may send a retry either on the CSS channel or alternatively on the appropriate assigned channel. Conversely, after sending a random access request on an assigned channel and not receiving a response within the waiting time WT, the MS may send a retry either on the same assigned channel or alternatively on the CSS channel. When the MS wishes to send a retry on a channel, it shall choose a subslot from a new access frame using an appropriate frame marker received on that channel.

When the MS obeys a channel allocation with "allocation type" = 11<sub>2</sub> (i.e. Replace + CSS channel) where the specified carrier is the main carrier, the MS may, if capable, use the MCCH or the appropriate common SCCH for that MS in addition to the assigned channel (see clause 23.5.4.2.1 d)). Then the same random access procedures shall apply on the MCCH or common SCCH as defined above for a CSS channel except that the MS shall regard the MCCH or common SCCH as a common control channel and therefore an uplink slot has an appropriate common/assigned designation only if it is designated as "common only" or "common and assigned".

#### 23.5.1.4.16 Random access operation with extended random access channel

When an extended random access channel has been defined by the BS, the MS-MAC shall obey the procedures defined in the earlier clauses within clause 23.5.1.4. So, for example:

- a) The ALOHA parameters (e.g. IMM, WT, Nu, frame-length factor) received on the downlink control channel apply to the extended random access channel defined by element "Timeslot Pointer";
- b) A subslot is a valid access opportunity if the slot corresponds to element "Timeslot Pointer" for this control channel and has an appropriate common/assigned designation (as defined in c)), and the subslot has an appropriate access code and is not reserved nor assigned for linearization;
- c) If the MS is on a common control channel (i.e. MCCH or common SCCH) then the slot has an appropriate common/assigned designation only if the uplink slot is designated as "common only" or "common and assigned";

If the MS is on an assigned channel then the slot has an appropriate common/assigned designation only if the uplink slot is designated as "common and assigned" or "assigned only".

NOTE 1: Thus the MS applies the same check on the common/assigned designation to all slots of the random access channel defined by element "Timeslot Pointer", irrespective of whether the same-numbered downlink slot is part of the downlink control channel.

- d) When the MS chooses a subslot from a new access frame, it may use a frame marker from any slot corresponding to element "Timeslot Pointer" for this control channel if the slot has an appropriate common/assigned designation (as defined in c)), and the subslot has an appropriate access code;
- e) When counting access subslots to its chosen slot in an access frame, the MS counts all valid access subslots (as defined in b)) i.e. it counts all subslots corresponding to element "Timeslot Pointer" if they have an appropriate common/assigned designation and access code and are not reserved nor assigned for linearization.

Thus all the access subslots corresponding to element "Timeslot Pointer" are equivalent for the purposes of the random access procedure.

When waiting for a response from the BS, the MS looks for the response in the downlink slots appropriate to the downlink control channel (as indicated by the SYSINFO PDU or by the "Timeslot Assigned" element in the MAC-RESOURCE or MAC-END PDU that sent the MS to the channel).

NOTE 2: As in clause 23.5.1.4.8, the MS counts a maximum of one slot per TDMA frame for waiting time WT. See also clauses 23.5.1.4.12, 23.5.1.4.13 and 23.5.1.4.14.

NOTE 3: In the first sentence of clause 23.5.1.4.3 (i.e. where it is specified that the MS makes only one random access attempt at a time, per control channel), the expression "per control channel" refers to the combination of the downlink control channel and the extended random access channel.

## 23.5.2 Reserved access

The random access protocol is generally needed when the MS-MAC wishes to initiate a transaction. However, when an MS-MAC is required to send a solicited message or when it has further signalling to send after the initial access, the BS may reserve slots for that particular MS.

The ACCESS-ASSIGN PDU (on the AACH) indicates which subslots are reserved and therefore not available for random access by other MSs. The MS-MAC for which a subslot or slot(s) are reserved is informed on the downlink signalling channel, using the MAC-RESOURCE or MAC-END PDU.

This clause describes the MS procedures for requesting reserved slots, and the procedures for granting and using reserved slots.

### 23.5.2.1 Reservation requirement

The MAC-ACCESS, MAC-DATA, MAC-END-HU and MAC-END PDUs on the uplink all allow the MS-MAC to indicate its reservation requirement on this control channel. The "reservation requirement" element is an optional element and shall not be included unless the MS has further signalling ready to send.

If the MS has further signalling to send for this address on this control channel, the MS-MAC shall include the "reservation requirement" element whenever it transmits an SCH/HU or SCH/F MAC block containing a MAC-ACCESS, MAC-DATA, MAC-END-HU or MAC-END PDU. If PDU association is used within the MAC block then the "reservation requirement" element shall be included in the last PDU in the MAC block.

The "reservation requirement" element shall indicate the MS's estimate of the total capacity required for any further signalling messages (basic link or advanced link) that it currently has ready to send for this individual address on this control channel. The method for the MS-MAC to calculate the required capacity for a fragmented message is described in clause 23.4.2.1.2. The required capacity for other signalling ready to send is known from the "Amount of data in LLC buffer" parameter in the DATA-IN-BUFFER signal received from the LLC.

NOTE 1: The reservation requirement indicates the total amount of C-plane signalling that the MS wishes to send for this address, irrespective of whether or not the MS has already been granted some future slots.

NOTE 2: The reservation requirement procedure applies only to signalling messages to be sent with an individual address, i.e. the MSs ISSI/ASSI, USSI, SMI or corresponding event label. The BS grants a subslot or slot(s) for the group address when it invokes a low level group presence indication, so the reservation requirement procedure does not apply to group addresses.

NOTE 3: When the MS indicates its reservation requirement, it indicates only the required capacity for the address with which the reservation requirement is sent. The ISSI and its associated ASSI are regarded as equivalent for the purposes of this procedure. Similarly, an event label and its corresponding address are regarded as equivalent for the purposes of this procedure. However, an MS is not permitted to combine any reservation requirements for its SMI with requirements for an SSI (or vice versa), and it is not permitted to combine the reservation requirements for multiple TSI families.

The MS-MAC may indicate a reservation requirement of one subslot, or one or more full slots (as shown in clause 21). The required number of slots is coded in a non-linear format. If the MS's requirement cannot be represented exactly within the defined format, the MS-MAC shall round down to the next lower valid number of slots, except possibly in the case of a MAC-ACCESS or MAC-DATA PDU containing the start of fragmentation. In the case of the start of fragmentation, the reservation requirement shall cover at least the capacity needed for the remainder of the fragmented message.

NOTE 4: The above exception is needed for fragmented messages because the MAC-FRAG PDU cannot include a "reservation requirement" element. Therefore, if the MS needs 7 slots to send the rest of the TM-SDU, it asks for 8 slots (or more if it has other signalling to send); or, if it needs 9 slots to send the rest of the TM-SDU, it asks for 10 slots (or more). In all other cases, the "rounding down" rule applies.



### 23.5.2.2 Slot granting

The BS may allocate reserved slots to an MS either:

- a) after receiving a request for reserved capacity from the MS; or
- b) when the BS sends the MS a message that requires a response.

The BS shall perform the allocation by including the "slot granting" element in a MAC-RESOURCE or MAC-END PDU sent to the MS. The "slot granting" element is an optional element, included only when required.

In case b), the "slot granting" element will generally be included in the same downlink PDU as the invoking message. For a fragmented downlink TM-SDU, the grant may be included in either the MAC-RESOURCE or the MAC-END PDU.

For the MAC-RESOURCE PDU, the slot grant shall refer to the MS addressed in the MAC header. For the MAC-END PDU, the slot grant shall refer to the MS receiving the fragmented message (addressed in the MAC-RESOURCE PDU that contained the first fragment).

The "slot granting" element shall be sent by the BS, and understood by the receiving MS-MAC, in the format shown in clause 21. It shall consist of two sub-elements:

- 1) Capacity allocation:
  - This element shall indicate the amount of reserved capacity that is granted on the uplink channel. It may indicate either a single subslot or one or more full slots.
- 2) Granting delay:
  - This element shall indicate the time of the start of the reservation. It shall have one of the following forms:
    - start in the next uplink slot on this channel (granting delay =  $0000_2$ ). For both single-slot and multi-slot channels, this shall refer to the same-numbered uplink timeslot as the slot containing the slot grant, in the same TDMA frame;
    - delay for the specified number of delay opportunities on this uplink channel (granting delay =  $0001_2$  to  $1101_2$ ). See clause 23.5.2.2.1 for the definition of delay opportunities;
    - start in the first uplink opportunity in the next frame 18 (granting delay =  $1110_2$ ). For a slot grant sent in frame 18, this shall refer to the following frame 18 (after this one);
    - wait for another slot grant (granting delay =  $1111_2$ ). This form does not actually grant slots at this time, but shall serve to restart the MS's timer T.206, thereby preventing the MS-MAC from reverting to random access.

After any granting delay, a grant for one subslot or slot shall apply to the next slot on this uplink channel. For a subslot grant, the "capacity allocation" element shall indicate whether the MS shall use the first or second subslot.

NOTE: For a grant of a first subslot or a full slot, it is the responsibility of the BS not to send a granting delay which indicates that the granted capacity is in an uplink slot in frame 18 corresponding to one of the predefined CLCH opportunities. This applies also to the first slot of a grant of more than one slot. If an MS receives a slot granting PDU that does not conform to this limitation then it should ignore the slot grant.

However, the BS may grant the second subslot for reserved access in an uplink slot in frame 18 corresponding to one of the predefined CLCH opportunities.

When several slots are granted, these shall occupy successive slots on this uplink channel (after any granting delay) except that the MS shall jump over those slots in frame 18 that contain predefined CLCH opportunities. As defined in clause 9 and clause 23.4.5, predefined CLCH opportunities in frame 18 occur when  $(MN + TN) \bmod 4 = 3$ .

If the MS-MAC receives multiple slot grants for an individual address or valid event label, it shall assume that its current allocation is the combination (i.e. union) of slot grants on this control channel.

Capacity that has been granted cannot be withdrawn by the BS. However, if the MS indicates that it has no further signalling to send (see clause 23.5.2.3.1), then the BS may re-use any remaining granted capacity for another MS.

### 23.5.2.2.1 Slot granting in normal mode

On the MCCH, the uplink for reserved access shall occupy only slot 1 of the main carrier. For a capacity allocation of more than one slot, this refers to the use of successive slot 1s except that the MS shall jump over those slots in frame 18 that contain predefined CLCH opportunities.

**EXAMPLE:** a three-slot granted allocation starting in slot 1 of frame 8 occupies also slot 1 of frames 9 and 10; a four-slot granted allocation starting in slot 1 of frame 16 of multiframe 2 occupies also slot 1 of frames 17, 1 and 2.

For a common SCCH, the same rule shall apply, except with the appropriate slot number on the main carrier.

For an assigned SCCH or for an ACCH, the uplink for reserved access shall occupy the timeslot(s) per TDMA frame indicated in the "Timeslot Assigned" element from the MAC-RESOURCE or MAC-END PDU that allocated the channel except that the MS shall jump over those slots in frame 18 that contain predefined CLCH opportunities.

**EXAMPLE:** For an assigned SCCH using timeslots 3 and 4, a four-slot granted allocation starting in slot 4 of frame 10 occupies also slots 3 and 4 of frame 11 and slot 3 of frame 12; a six-slot granted allocation starting in slot 3 of frame 17 of multiframe 3 occupies also slot 4 of frame 17, slot 3 of frame 18, slots 3 and 4 of frame 1 and slot 3 of frame 2.

The granting delay is given in terms of the number of opportunities for reserved access on this channel except that, when counting slots for the granting delay, the MS shall include those slots in frame 18 that contain predefined CLCH opportunities. So, for a single-slot channel, the granting delay indicates the delay in TDMA frames; whereas, for a multi-slot channel, there are two or more opportunities per TDMA frame.

**EXAMPLE:** For example, on the MCCH, for a slot grant sent in frame 15 with a granting delay of  $0100_2$  (i.e. 4 opportunities delay), the granted capacity starts in slot 1 of frame 1 irrespective of the multiframe number. On an assigned SCCH using timeslots 1 and 2, for a slot grant sent in slot 2 of frame 4 with a granting delay of  $0101_2$  (i.e. 5 opportunities delay), the granted capacity starts in slot 1 of frame 7.

**NOTE 1:** The width of the uplink channel for reserved access is the same as the width of the downlink channel. It is defined independently of any extension of the uplink channel for random access.

**NOTE 2:** The counting of slots for the granting delay is defined in absolute terms given the known number of timeslots per TDMA frame for this channel. The use of granted slots by the MS is defined in absolute terms given the known number of timeslots per TDMA frame for this channel and the predefined mapping of CLCH opportunities in frame 18. The MS transmits in the granted slots without needing to check the ACCESS-ASSIGN PDU.

For example, on a channel assigned for traffic, the MS should follow the normal methods for counting slots for the granting delay and for using reserved slots. It is the responsibility of the BS to avoid granting slots where another MS may be transmitting traffic. Therefore, when the uplink is in SACCH so that only frame 18 is available for reserved access, the BS should grant only one reserved subslot or slot at a time. (The BS should use either granting delay =  $0000_2$  or  $1110_2$  when sending the slot grant in downlink frame 18 since, for example, if it were to use granting delay =  $0001_2$ , the MS would regard this as an instruction to transmit in frame 1.)

The BS should not grant the first subslot or a full slot in a frame 18 slot that corresponds to one of the predefined CLCH opportunities. It is also the responsibility of the BS to avoid assigning CLCH subslots in frames 1 to 17 in positions that coincide with granted slots.

### 23.5.2.2.2 Slot granting in minimum mode

During minimum mode, if the BS sends a slot granting PDU in an MS's designated minimum mode frame 18 slot, and if that slot is slot 2, 3 or 4, then the BS shall grant only one reserved subslot or slot in that PDU. The granted subslot or slot shall be scheduled either in the corresponding uplink slot of that frame 18 (Granting delay =  $0000_2$ ) or in the corresponding uplink slot of the following frame 18 (Granting delay =  $1110_2$ ).

If an MS in minimum mode receives a slot granting PDU in slot 2, 3 or 4 of frame 18 that does not conform to the above limitations, then it shall ignore the slot grant.

NOTE 1: The above limitations apply only to those MSs that are in common control mode, having been monitoring the MCCH. They do not apply to MSs on an assigned channel that are using slot 2, 3 or 4 of frame 18 within their ACCH.

NOTE 2: The BS should not grant the first subslot or a full slot in a frame 18 slot that corresponds to one of the predefined CLCH opportunities.

For a slot grant sent in slot 1 of frames 1 to 17, or in slot 1 of frame 18, the BS may make a capacity allocation of more than one slot; this shall then refer to the use of successive uplink slot 1s except that the MS shall jump over those slots in frame 18 that contain predefined CLCH opportunities (i.e. the normal method).

### 23.5.2.2.3 Slot granting on time-shared control channel

On a time-shared MCCH, the BS may send a slot granting PDU either in one of its own reserved frames or in a common frame. It may grant single subslots, or one or more full slots.

The delay opportunities for counting the granting delay comprise the combination of:

- a) slot 1 of the reserved frames for this BS; and
- b) slot 1 of the common frames.

So the MS shall count successive slot 1s, except that it shall jump over frames that are neither reserved for this BS nor common.

The opportunities for reserved access for using a grant of more than one slot comprise the combination of:

- a) slot 1 of the reserved frames for this BS; and
- b) slot 1 of the common frames,

except that the MS shall jump over those slots in frame 18 for which  $(MN + TN) \bmod 4 = 3$ . So the MS shall use successive slot 1s, except that it shall jump over frames that are neither reserved for this BS nor common and shall jump over those slots in frame 18 for which  $(MN + TN) \bmod 4 = 3$ .

For a time-shared common SCCH, "slot 1" in the above procedure shall be replaced by the appropriate slot number on the main carrier.

NOTE: The network is responsible for co-ordinating the use of the uplink on time-sharing cells, to avoid collisions in granted slots.

### 23.5.2.2.4 BS slot granting operation

The BS may use the facilities for slot granting defined above.

After granting a subslot or slots, the BS should mark the equivalent uplink subslots as "reserved" in the ACCESS-ASSIGN PDU, thereby preventing other MS from sending random accesses. For example, after granting one slot, the BS should mark the two equivalent uplink subslots as "reserved".

If the BS does not receive a message in an individually granted subslot or slot, this may be either because the MS did not receive the downlink message or because the uplink message was corrupted during propagation. The BS may decide to send another slot granting PDU to the MS. In particular, if the BS does not receive a message in the first slot of a grant of several slots, it is recommended that the BS sends another slot granting PDU re-granting the remainder of the slots to the same MS (and further slots if appropriate).

For slot granting PDUs, as for all downlink PDUs, the BS should take account of any energy economy or dual watch operation in the MS, sending the PDU in a slot where the MS should be listening.

When the BS allocates reserved slots on a multi-slot Packet Data Channel (PDCH), it should use the information on the MS capabilities from the SMDCP's "resource request" element (see clause 28) when deciding on the amount of reserved capacity to allocate in one slot grant.

If the BS wishes to send data to a group, with a low level presence indication from recipient MSs, the BS shall include the group address and a slot grant in the MAC PDU that contains the invoking BL-DATA message. The slot grant may be for one subslot, or optionally for one or more full slots, though each MS in the group will use only one subslot; see clause 23.5.2.3.2. The methods whereby the BS detects transmission in the granted subslot (or slots) are left open for choice by system designers, e.g. measurement of received signal strength.

### 23.5.2.3 Use of reserved slots

#### 23.5.2.3.1 Individual address or event label

If an MS receives a MAC-RESOURCE PDU or MAC-END PDU containing a "slot granting" element for one of its individual addresses (i.e. its ISSI, ASSI, USSI or SMI) or for a valid individual event label for this control channel, the MS-MAC shall perform the following actions relating to the "slot granting" element. Other actions may be performed relating to other elements in the MAC header.

The MS-MAC shall inspect the "capacity allocation" and "granting delay" elements and shall record which subslot or slot(s) are allocated to it, as described in clause 23.5.2.2.

If the MS has signalling messages to send for this address on this control channel, as known from the DATA-IN-BUFFER signal, then the following procedure applies for each allocated subslot or slot:

- For an allocated subslot, the MS-MAC shall use logical channel SCH/HU; it shall send the final fragment of a fragmented TM-SDU, or otherwise a message from the LLC (or messages by association), except in the following case. If the MS has signalling to send but cannot use a subslot, e.g. if it has only full-slot advanced link messages to send, then the MS-MAC shall send a MAC-ACCESS PDU containing the "reservation requirement" element and no TM-SDU.
- For an allocated slot, the MS-MAC shall use logical channel SCH/F; it shall send the next fragment of a fragmented TM-SDU, or otherwise a message from the LLC (or messages by association).

After transmitting a complete TM-SDU, or a final fragment, the MS-MAC shall report to the LLC that the message has been sent by reserved access (using the TMA-REPORT indication primitive).

If the MS has no signalling message to send for this address on this control channel then the MS-MAC shall send the Null PDU in the allocated subslot or slot.

After sending:

- the Null PDU in an SCH/HU or SCH/F MAC block; or
- any SCH/HU MAC block that does not include a "reservation requirement" element; or
- any SCH/F MAC block that contains a MAC-DATA or MAC-END PDU, and does not include a "reservation requirement" element;

the MS shall not use any other capacity that has already been granted for this address on this control channel (whether in one slot granting PDU, or more than one). If the MS receives a further slot granting PDU, and if it still has no signalling messages to send for this address, then it shall send the Null PDU in the first allocated slot, or in the allocated subslot, and shall not use the remainder of the allocation.

NOTE 1: The ISSI and its associated ASSI are equivalent for the purposes of use of reserved slots (so the MS may use any subslot or slot(s) granted on its ISSI for messages sent with its ASSI, or vice versa). Similarly, an event label and its corresponding address are equivalent for the purposes of use of reserved slots.

Also, a newly assigned ASSI is equivalent to the replaced ASSI or USSI for the purposes of use of reserved slots. Thus, if an MS receives a slot grant on its ASSI then it may use the subslot or slot(s) for messages sent using a new ASSI which replaces that ASSI; and, if a migrating MS receives a slot grant on its USSI while that USSI is still valid then it may use the subslot or slot(s) for messages sent with its ASSI.

However, an MS is not permitted to use a subslot or slot(s) granted on an SSI for messages to be sent with its SMI, or vice versa; also, it is not permitted to use a subslot or slot(s) granted on one SSI for an SSI from another TSI family. These restrictions may possibly be relaxed in future editions of the present document in the case of the final slot of an MS's requested reserved capacity.

NOTE 2: As defined above, a migrating MS that receives a slot grant on its USSI while that USSI is still valid may use the subslot or slot(s) for messages sent with its ASSI. However, there is possible contention on capacity granted on the USSI if multiple migrating MSs with the same USSI are trying to register at the same time. Therefore, when assigning the ASSI, the BS may prefer not to allocate more than one reserved slot on the USSI. This is because any continuation or final fragments of an uplink message sent with the ASSI do not contain addressing information.

#### 23.5.2.3.2 Group address

If an MS receives a MAC-RESOURCE PDU or MAC-END PDU containing a "slot granting" element for one of its valid group addresses, the MS-MAC shall perform the following actions relating to the "slot granting" element. Other actions may be performed relating to other elements in the MAC header.

The MS-MAC shall inspect the "capacity allocation" and "granting delay" elements and shall see note which subslot or slot(s) are allocated, as described in clause 23.5.2.2. If the MS has a signalling message with this group address to send on this control channel then it shall transmit the message in an uplink subslot using the MAC-ACCESS PDU:

- a) for a subslot grant, it shall use the allocated subslot;
- b) for a grant of one or more slots (G slots), it shall choose one subslot randomly from the grant, i.e. random choice between 1G and 2G using a uniform distribution.

Otherwise, the MS shall not transmit.

NOTE: This procedure is used only for the low level group presence indication (see clauses 22.2.1.3 and 22.3.1.2).

#### 23.5.2.4 Reverting to random access

If the following criteria are all satisfied then the MS-MAC may initiate the random access procedure (see clause 23.5.1):

- a) the MS-MAC has sent a PDU (MAC-ACCESS, MAC-DATA, MAC-END-HU or MAC-END) indicating a reservation requirement for this address on this control channel; and
- b) the MS-MAC does not currently have any capacity granted for this address on this control channel; and
- c) a time T.206 has elapsed since:
  - the MS-MAC last sent a PDU on this control channel for this address (i.e. either a MAC-ACCESS or MAC-DATA PDU with this address or a MAC-FRAG, MAC-END or MAC-END-HU PDU relating to this address); or
  - the MS-MAC last received a slot granting element for this address on this control channel containing the instruction to "Wait for another Slot Grant";
 whichever is the later; and
- d) the MS still has signalling messages to send for this address on this control channel (as indicated by the DATA-IN-BUFFER signal).

The random access request shall be sent on SCH/HU using the MAC-ACCESS PDU, containing a TM-SDU if appropriate. If the MS has any further signalling ready to send for this address on this control channel, the MS-MAC shall include a request for reserved capacity ("reservation requirement" element) in the MAC-ACCESS PDU.

NOTE 1: T.206 must be greater than, or equal to, the fragmentation time-out constant T.202. Then, at the time of reverting to random access, the MS-MAC will not be in the process of an uplink fragmentation.

NOTE 2: Time T.206 is counted in downlink signalling opportunities (see annex B). So, for example, in minimum mode the absolute time is 18 times its normal value.

#### 23.5.2.5 Example of reservation process

This clause gives an example of the reservation process.

The MS-MAC has received a TMA-UNITDATA request primitive from the LLC, containing a long TM-SDU (length 512 bits). It uses a MAC-ACCESS PDU for the random access, including the first 56 bits of the TM-SDU and indicating a "reservation requirement" of two slots. The BS sends a MAC-RESOURCE PDU to acknowledge the random access request. The MAC-RESOURCE PDU also includes a "slot granting" element, granting the two required slots. The MS-MAC then sends the remainder of the TM-SDU in one MAC-FRAG PDU (264 bits of TM-SDU) and the MAC-END PDU (final 192 bits). The MS has no further signalling to send for this address, so the MAC-END PDU does not contain the "reservation requirement" element, and the MAC block is completed with the Null PDU and fill bits.

### 23.5.3 Cancel request

The LLC may use the TMA-CANCEL request primitive to stop the MAC activities relating to a particular TMA-UNITDATA request. The "handle to the request" references the service request that is to be aborted.

On reception of a TMA-CANCEL request primitive from the LLC, the MS-MAC shall cease all activities related to the service request as identified by its handle. The MS-MAC shall report to the LLC that MAC transmission activities have been aborted, indicating whether:

- a) the TM-SDU has not been completely sent; or
- b) the complete TM-SDU has been sent at least once,

using the TMA-REPORT indication primitive.

NOTE 1: This procedure can be used by the LLC to abort transmission of a message until:

- the complete TM-SDU, or final fragment of a fragmented TM-SDU, has been sent by reserved access or by stealing; or
- the complete TM-SDU has been sent and acknowledged by random access.

After a first transmission of a random access message, the TMA-CANCEL request stops the MS-MAC from sending further random access retries. However, it should be seen that the BS may have received the message.

NOTE 2: The primitive TMA-CANCEL request is used for modelling purposes only.

### 23.5.4 Channel allocation

#### 23.5.4.1 Transmission of channel allocation

The BS may send a channel allocation command either:

- a) to instruct an addressed MS (or MSs) to move from the current channel to another channel; or
- b) to allocate an additional channel for the addressed MS (or MSs). If the MS does not support concurrent MAC services (i.e. if it is not capable of operating on multiple channels) then it may either remain on the current channel and reject the new service or move from the current channel to the new channel and accept the new service.

The BS shall perform the allocation by including the "channel allocation" element in a MAC-RESOURCE or MAC-END PDU. The "channel allocation" element is an optional element, included only when required.

The channel allocation is generally sent in a MAC-RESOURCE PDU. However, if the BS wishes to send channel allocation information with a fragmented message then that information shall be included within the MAC-END PDU and shall not be included within the MAC-RESOURCE PDU.

For the MAC-RESOURCE PDU, the channel allocation shall refer to the MS or MSs addressed in the MAC header. For the MAC-END PDU, the channel allocation shall refer to the MS or MSs receiving the fragmented message (addressed in the MAC-RESOURCE PDU that contained the first fragment).

The channel allocation command may be used to allocate a different channel (timeslot or timeslots) on the current RF carrier or to change both the carrier and timeslot(s) (see clause 21).

When the BS directs the MS to an assigned channel, it shall set element "timeslot assigned" to indicate the appropriate timeslot(s), as a bit map. If the BS wishes the MS to return to a common control channel (i.e. MCCH or common SCCH), it shall set "timeslot assigned" = 0000<sub>2</sub> and indicate the main carrier number.

The channel allocation command may be used to allocate a channel on the current cell. It may also be used to allocate a channel on another cell e.g. in case of announced cell reselection type 1. The "cell change flag" shall indicate whether the channel allocation is for another cell. For a channel allocation directing an MS to another cell, the bit map in element "timeslot assigned" shall refer to the timeslot numbering on the new cell.

NOTE 1: The channel allocation method is used for directing addressed MSs to a specified channel. In addition, the broadcast message SYSINFO PDU (the content of BNCH) may cause an MS to move from one common control channel to another, e.g. when the number of common SCCHs is changed (see clause 23.3). For such a move, the same endpoint identifier applies, and the same service to the LLC is maintained for basic link and for any individual advanced link.

NOTE 2: When the BS assigns a channel for a circuit mode call, the resource allocation should correspond to that required for the network layer basic service information for the call, (see clause 14). For example, the number of slots per frame allocated by element "timeslot assigned" should match the basic service information.

NOTE 3: It is optional for the MS to be capable of using a multi-slot channel, or of supporting concurrent channels on one carrier, or of supporting concurrent multi-carrier operation. The BS should use the information on MS capabilities provided in the mobile class when allocating resources, i.e. the "class of MS" element (see clause 16).

NOTE 4: In many cases, the MS may choose whether to move to an allocated channel (see clause 23.5.4.2). This applies for both individually addressed and group addressed channel allocations. BS designers should take account of this in their BS algorithms.

## 23.5.4.2 Reception of channel allocation

### 23.5.4.2.1 Channel allocation types

The channel allocation element includes a two-bit element "allocation type", which is intended to aid interpretation of the allocation. The precise procedures are defined in clauses 23.5.4.2.2, 23.5.4.2.3 and 23.5.4.2.4.

The values for the "allocation type" are as follows:

- a) 00<sub>2</sub>: Replace current channel with specified channel.

This indicates that the allocated channel is intended to replace the current channel (i.e. the channel on which the command was received). This replacement applies only to the channel on which the command was received, not to any other concurrent channels that the MS may be using on that carrier. If the current channel is a multi-slot channel, the replacement applies to all the timeslots comprising that channel.

The "Replace" mechanism may be used to move the MS to a different resource allocation. Otherwise it may be used if the BS wishes to increase or decrease the number of slots allocated to a particular assigned channel; the BS sends a "Replace" channel allocation on the assigned channel indicating the revised slot allocation.

- b) 01<sub>2</sub>: Additional channel allocation.

This indicates the allocation of an additional independent channel for an independent service e.g. a concurrent service. It cannot be used for changing the configuration of the current channel (see above).

- c) 10<sub>2</sub>: Quit current channel and go to specified channel.

This allows the BS to replace the current channel but without maintaining full service. This means that the physical layer service is no longer available for the higher layers to use, though the higher layer service is not necessarily disconnected. Any current traffic transmit/receive authorization does not apply on the new channel (see clause 23.8.2).

- d) 11<sub>2</sub>: Replace current channel with specified channel, plus MCCH/SCCH or additional carrier specific signalling channel (CSS channel) in timeslot 1.

This indicates that the specified channel is intended to replace the current channel (i.e. the channel on which the command was received). If the specified carrier is the main carrier, it indicates that the MS may, if capable, use also the MCCH or the appropriate common SCCH for that MS. If the specified carrier is not the main carrier, it indicates that the MS may, if capable, use timeslot 1 as an additional channel (referred to as a CSS channel) to increase signalling capacity between the MS and BS. If the MS is not capable of receiving both the specified channel and the MCCH/SCCH or CSS channel then the specified channel shall take precedence.

If the specified carrier is the main carrier and the MS chooses to use the MCCH or the appropriate common SCCH then it shall regard that channel as a common control channel (in the usual way), within the capabilities of that MS.

If the specified carrier is not the main carrier and the MS chooses to use the CSS channel then it shall regard that CSS channel as an independent single-slot channel. For the purposes of the general procedures for transmission and reception of signalling messages, the MS shall apply those procedures as if the CSS channel were an assigned channel, allocated by a specific MAC-RESOURCE or MAC-END PDU with "timeslot assigned" = 1000<sub>2</sub>, i.e. allocation of timeslot 1. However, the MS is only required to receive the CSS channel within the capabilities of that MS. Also, reduced channel maintenance procedures shall apply on the CSS channel, and the CSS channel becomes invalid when the MS has no other assigned channel on that carrier (see clause 23.5.6.2).

**EXAMPLE:** The BS might decide to allocate a CSS channel to provide information to MSs on that carrier about new calls, e.g. late entry signalling, without disturbing the operation of the assigned SCCHs and traffic channels on the other timeslots. The CSS channel could also be used for other signalling purposes such as status messages or packet data.

The BS may allocate the CSS channel to all MSs using that carrier, by setting the "allocation type" to 11<sub>2</sub> in all the channel allocations. Slot 1 could also be an assigned channel for some MSs e.g. for advanced links with low data transfer throughput. The channel is then shared between the MSs.

An MS in a circuit mode call may, for example, send the U-TX-DEMAND PDU on the CSS channel, e.g. with a high priority request. However, if FACCH is available on the assigned channel, then the MS should use this in preference to the CSS channel.

If an MS has an advanced link on its assigned channel then it cannot send signalling related to that advanced link on the CSS channel.

**NOTE 2:** The MS only receives the common channel (i.e. MCCH or common SCCH) or CSS channel within the capabilities of that MS. For example, a frequency half duplex MS in a simplex circuit mode call is permitted to receive the common or CSS channel while it is receiving traffic on the assigned channel even if it is not capable of receiving the common or CSS channel while it is transmitting traffic.

In many cases, the MS may choose whether to obey a channel allocation e.g. if the channel allocation is received on the MCCH or on a common SCCH, or for an additional channel allocation. The MS-MAC refers to the higher layers for a decision. For a group addressed channel allocation, the higher layers may either make an immediate decision on whether to accept the channel allocation or may delay the decision. However, for an individually addressed channel allocation, the MS needs to make an immediate decision on whether to accept a particular channel allocation.

**NOTE 3:** For a group call, especially on a (quasi-)transmission trunked system, the MS may sometimes receive a channel allocation on the group address and sometimes on its individual address.

When the higher layers respond with their decision on whether to accept a channel allocation, they may indicate "accept" or "reject" or, in some cases, they may indicate "ignore". The MAC actions for "reject" and "ignore" are the same except when a "replace" or "replace + CSS channel" or "quit" channel allocation is received on an assigned channel or when a "quit" channel allocation is received on a CSS channel (see clauses 23.5.4.2.3 and 23.5.4.2.4).

**NOTE 4:** The "reject" instruction is used when the higher layers may choose not to accept the channel allocation. The "ignore" instruction applies only in specific protocol cases when the higher layers are required by the protocol to ignore specific PDUs and any channel allocation received with those PDUs e.g. when the MS is transmitting traffic and it receives a group addressed D-TX GRANTED or D-TX INTERRUPT PDU, or in some instances of receipt of a group addressed D-SETUP PDU when the MS is trying to make a call to that group (see clause 14.5.2).



The following procedures for reception of a channel allocation indicate the physical layer service provided by the channel to the higher layers. This applies principally to any advanced links, since signalling messages for concurrent advanced links for one address are discriminated only locally, by an endpoint identifier which corresponds to a particular MAC channel (timeslot or timeslots).

The MS-MAC generally uses the TMC-CONFIGURE indication primitive to inform the higher layers when it has lost physical resources. The use of the TMA-RELEASE indication primitive for indicating loss of the connection (as defined in clause 23.5.4.2.3 procedure a1, or if the MS leaves the channel as a result of channel maintenance procedures) should not occur except in error conditions.

#### 23.5.4.2.2 Reception of channel allocation on MCCH or common SCCH

If the MS receives a channel allocation on the MCCH or on a common SCCH for one of its valid addresses or for a corresponding event label, then the "allocation type" may be 00<sub>2</sub> (Replace current channel) or 01<sub>2</sub> (Additional channel) or 11<sub>2</sub> (Replace current channel, and add CSS channel).

If a TM-SDU was included within the PDU that allocated the channel then the MS-MAC shall set the "channel change response required" parameter to "true" in the TMA-UNITDATA indication primitive, to indicate that a response is required to instruct the MS-MAC whether it should obey the allocation. The MS-MAC shall generate a local identifier for the channel allocation, referred to as the "channel change handle", and shall include it in the TMA-UNITDATA indication primitive, enabling unique identification of the related response from the higher layers. If a TM-SDU was not included within the PDU that allocated the channel then the MS-MAC shall issue a TMA-UNITDATA indication primitive containing the "channel change response required" parameter set to "true" (and a channel change handle) and with no TM-SDU.

NOTE 1: It is optional for the MS to obey a channel allocation received on the MCCH or on a common SCCH. According to the protocol model, the MS-MAC refers to the higher layers so that, for example, for a circuit mode group call, the MS-MAC does not move to the channel if the CMCE does not accept the associated message. However, in an implementation, the MS is permitted to obey all individually addressed channel allocations in which case the primitive exchange is unnecessary in practice.

When the BS sends a channel allocation on the MCCH or on a common SCCH, it is recommended that the BS includes a higher layer message indicating the intended usage of the channel allocation. Even if only an LLC acknowledgement is included with the channel allocation, this may enable the MS to deduce the intended usage (e.g. in the case of medium channel assignment to a called MS).

If "allocation type" = 01<sub>2</sub> and the MS is capable of operating with concurrent channels and the MS is not already receiving the indicated channel then the MS-MAC shall allocate an endpoint identifier for the new channel. The MS-MAC shall include both the endpoint identifier of the current channel (i.e. the channel on which the channel allocation PDU was received) and the endpoint identifier of the newly allocated channel (parameter "new endpoint identifier") in the TMA-UNITDATA indication primitive.

NOTE 2: A new endpoint identifier will usually be required. However, for example, in the case of independent allocation of uplink and downlink for concurrent calls involving the same MS, that MS may receive independent channel allocations with the same carrier number and same element "timeslot assigned" but with a different "Up/downlink assigned" element.

NOTE 3: The new endpoint identifier enables the higher layers to make correct usage of the new channel if the MS-MAC obeys the channel allocation. For example, for an AL-SETUP PDU for a new advanced link, sent with the additional channel allocation, the new advanced link is on the allocated channel.

If "allocation type" = 11<sub>2</sub> and the MS is capable of using the common or CSS channel then the MS-MAC shall allocate an endpoint identifier for the common or CSS channel. The MS-MAC shall include both the endpoint identifier of the current channel and the endpoint identifier of the common or CSS channel (parameter "CSS endpoint identifier") in the TMA-UNITDATA indication primitive.

NOTE 4: The CSS endpoint identifier enables the higher layers to make correct usage of the common or CSS channel if the MS-MAC obeys the channel allocation.

The MS-MAC should then receive a response (TMC-CONFIGURE request primitive) from the higher layers indicating whether it should obey the allocation. For an individually addressed channel allocation, the MS-MAC should expect that the response from the higher layers will be immediate. However, for a group addressed channel allocation, the response from the higher layers may be immediate or may be delayed, in which case the MS-MAC continues to obey the normal MAC procedures on the MCCH or common SCCH in the interim time.

NOTE 5: For the purposes of the protocol description, it is assumed that, in the case of an immediate decision by the higher layers, the process of the MAC issuing the TMA-UNITDATA indication primitive and then receiving the corresponding TMC-CONFIGURE request primitive is effectively instantaneous.

If the higher layers return a TMC-CONFIGURE request primitive containing the "channel change accepted" parameter set to "reject" or "ignore" then the MS-MAC shall ignore the channel allocation corresponding to the channel change handle. The MS may use any subslot or slot(s) that are granted on the current channel but shall ignore a slot grant if element "position of grant" in the channel allocation PDU indicated the allocated channel.

If the higher layers return a TMC-CONFIGURE request primitive containing the "channel change accepted" parameter set to "accept" then the MS-MAC shall obey the channel allocation command corresponding to the channel change handle, using the appropriate procedure a) or b):

- a) If "allocation type" = 00<sub>2</sub> (Replace) or 11<sub>2</sub> (Replace + CSS channel) in the channel allocation element then the MS shall move from the current channel (i.e. the channel on which the channel allocation PDU was received) to the specified channel. It shall assume that the allocated channel will provide the same service to the LLC for this address as the current channel, corresponding to the same endpoint identifier (see note 6).

If the MS was receiving other channels on the main carrier, and it is not capable of receiving those other channels as well as the newly allocated channel, then the MS-MAC shall issue a TMC-CONFIGURE indication primitive to the higher layers for any channels that it can no longer receive in order to indicate that the physical resource on those channels is lost. Otherwise, if the MS is capable of continuing to receive its other channels, then those other channels are not affected.

If "allocation type" = 00<sub>2</sub> then the MS shall not continue to use the MCCH or common SCCH.

If "allocation type" = 11<sub>2</sub> and the assigned carrier is the main carrier then the MS may, if capable, use also the MCCH or the appropriate common SCCH for that MS. If the assigned carrier is not the main carrier then the MS may, if capable, use slot 1 of the assigned carrier as a CSS channel. If the MS is not capable of receiving both the assigned channel and the common or CSS channel then the MS shall ignore the common/CSS part of the allocation.

NOTE 6: For a "replace" or "replace + CSS channel" command within the cell, the service provided to the LLC is maintained both for the basic link and for any advanced link for that address on the current channel. This applies even if the number of allocated timeslots changes (though, in this case, the MS is not precluded from performing an LLC reset). In the case of a cell reselection, the MLE decides whether to release current advanced links or attempt reconnection. If the MLE does not attempt reconnection then any current advanced links are released when the MS obeys a channel allocation indicating a cell change.

NOTE 7: A "replace" or "replace + CSS channel" command applies only to the channel on which the message was received, and so cannot be used to simultaneously replace other concurrent channels on that carrier when allocating a channel on another carrier. However, if the channel allocation PDU includes a slot grant on the current channel with "granting delay" > 0000<sub>2</sub> then the MS does not change channel immediately (see clause 23.5.4.3.1). During the interim time, the MS should continue to receive its other concurrent channels, since the BS may also send a "replace" or "replace + CSS channel" command on one of those channels, enabling both services to be maintained on the new carrier. Then, in the timing procedure for the carrier change, the MS may use the later (or latest) of the specified times.

- b) If "allocation type" = 01<sub>2</sub> (Add) in the channel allocation element then the MS shall obey the command to receive the allocated channel.

If the MS is not capable of receiving all concurrent channels as well as the newly allocated channel, then the MS-MAC shall issue a TMC-CONFIGURE indication primitive to the higher layers for those channels that it can no longer receive in order to indicate that the physical resource on those channels is lost. Otherwise the MS shall continue to receive all concurrent channels, including the channel on which the channel allocation PDU was received, as well as the newly allocated channel.

After a channel change, the MS-MAC shall inform the MLE about the channel now in use using the TMC-SELECT indication primitive.

### 23.5.4.2.3 Reception of channel allocation on assigned channel

If the MS receives a channel allocation on an assigned channel for one of its valid addresses or for a corresponding event label, then the "allocation type" may take any of the following four values:

- 00<sub>2</sub> (Replace current channel), in which case the MS shall assume that the allocated channel will provide the current service for that address;
- 01<sub>2</sub> (Additional channel), in which case the MS shall assume that the channel is intended for the purpose indicated in the higher layer message;
- 10<sub>2</sub> (Quit current channel), in which case the MS should assume that the current service on that channel is not fully maintained. This means that the physical layer service is no longer available for the higher layers to use, though the higher layer service is not necessarily disconnected. Any current traffic transmit/receive authorization does not apply on the new channel;
- 11<sub>2</sub> (Replace current channel, and add CSS channel), in which case the MS shall assume that the allocated channel will provide the current service for that address, and that timeslot 1 (or the MCCH or common SCCH) may be used for additional signalling.

NOTE 1: For a "replace" or "replace + CSS channel" command received while the MS is in a circuit mode call, current traffic transmit and/or receive authorization may apply on the allocated channel; refer to clause 23.8.2.

The MS-MAC shall follow the appropriate procedure a), b) or c):

- a) For allocation type 00<sub>2</sub> (Replace) or 11<sub>2</sub> (Replace + CSS channel), the appropriate procedure shall apply as follows:
  - 1) If a TM-SDU was not included within the PDU that allocated the channel, and:
    - the MS does not have a concurrent assigned channel; or
    - the MS would still be able to receive any concurrent assigned channels after moving to the allocated channel,

then the MS-MAC shall decide whether to obey the channel allocation as follows:

- if the MS is capable of using the allocated channel then the MS-MAC shall obey the channel allocation. The MS shall cease to receive the current channel (unless it has a concurrent independent allocation on that channel, see note 6) and shall move to the allocated channel.
- otherwise, if the MS is not capable of using the allocated channel (i.e. the replacement channel has a larger number of slots than the current channel and the MS cannot support the wider channel) then the MS-MAC shall reject the channel allocation. The MS-MAC shall cease to receive the current channel and shall issue a TMA-RELEASE indication primitive (unless it has a concurrent independent allocation on that channel, see note 6). The MS may use any subslot or slot(s) that are granted on the current channel but shall ignore a slot grant if element "position of grant" in the channel allocation PDU indicated the allocated channel. If the MS does not have a concurrent assigned channel, it shall return to the MCCH or appropriate common SCCH.

NOTE 2: For allocation type 11<sub>2</sub>: when the above procedure refers to the MS not being capable of using the allocated channel, this refers only to the allocated channel as indicated by element "timeslot assigned", not to the CSS channel.

- 2) If a TM-SDU was included within the PDU that allocated the channel, or the MS has a concurrent assigned channel that it would be unable to receive as a result of moving to the allocated channel, then the MS-MAC shall set the "channel change response required" parameter in the TMA-UNITDATA indication primitive to "true" (and shall include a channel change handle). The MS-MAC shall then wait for a response from the higher layers:
- if the higher layers return a TMC-CONFIGURE request primitive containing the "channel change accepted" parameter set to "accept" then the MS-MAC shall obey the channel allocation corresponding to the channel change handle. The MS shall cease to receive the current channel (unless it has a concurrent independent allocation on that channel, see note 6) and shall move to the allocated channel;
  - if the higher layers return a TMC-CONFIGURE request primitive containing the "channel change accepted" parameter set to "reject" then the MS shall cease to receive the current channel (unless it has a concurrent independent allocation on that channel, see note 6). The MS may use any subslot or slot(s) that are granted on the current channel but shall ignore a slot grant if element "position of grant" in the channel allocation PDU indicated the allocated channel. If the MS does not have a concurrent assigned channel, it shall return to the MCCH or appropriate common SCCH;
  - if the higher layers return a TMC-CONFIGURE request primitive containing the "channel change accepted" parameter set to "ignore" then the MS-MAC shall ignore the channel allocation corresponding to the channel change handle and continue to use the current channel. The MS may use any subslot or slot(s) that are granted on the current channel but shall ignore a slot grant if element "position of grant" in the channel allocation PDU indicated the allocated channel;
  - if the higher layers do not return a TMC-CONFIGURE request primitive containing the "channel change accepted" parameter within a time T.216 following receipt of the channel allocation then the MS shall cease to receive the current channel (unless it has a concurrent independent allocation on that channel, see note 6). If the MS does not have a concurrent assigned channel, it shall return to the MCCH or appropriate common SCCH. If the higher layers later return a TMC-CONFIGURE request primitive containing the "channel change accepted" parameter set to "accept" then the MS should move to the allocated channel.

NOTE 3: Thus, when the higher layers wish the MS-MAC to ignore a replacement channel allocation on an assigned channel, they must return the "channel change accepted" parameter set to "ignore" within a time T.216 in order for the MS-MAC to act on it.

NOTE 4: In the case of a channel allocation with a slot grant on the current channel, when the above procedures 1) and 2) refer to the MS ceasing to receive the current channel, the MS should not leave the channel until after the end of the last uplink slot granted by that PDU (or the end of the slot containing a granted subslot). Similarly, if the current channel is a multi-slot channel, and the next immediate uplink slot following the channel allocation is part of the current channel, and the MS is transmitting traffic in that slot or was previously granted that slot (or a subslot in that slot) for reserved access, the MS should not leave until after the end of that next immediate uplink slot.

- b) For allocation type 01<sub>2</sub> (Add), the MS-MAC shall set the "channel change response required" parameter in the TMA-UNITDATA indication primitive to "true" to indicate that a response is required to instruct the MAC whether it should accept the allocation (and shall include a channel change handle). If the decision is delayed for a group addressed channel allocation then the MS-MAC may continue to use the current channel in the interim time.

If the higher layers return a TMC-CONFIGURE request primitive containing the "channel change accepted" parameter set to "accept" then the MS-MAC shall obey the channel allocation command corresponding to the channel change handle. It may also continue to use the current channel if it is capable of doing so.

If the higher layers return a TMC-CONFIGURE request primitive containing the "channel change accepted" parameter set to "reject" or "ignore" then the MS-MAC shall ignore the channel allocation corresponding to the channel change handle and continue to use the current channel. The MS may use any subslot or slot(s) that are granted on the current channel but shall ignore a slot grant if element "position of grant" in the channel allocation PDU indicated the allocated channel.

- c) For allocation type 10<sub>2</sub> (Quit), the MS-MAC shall obey the procedure defined in procedure a) above for allocation type 00<sub>2</sub> (Replace) except that, if the MS ceases to receive the current channel, the MS-MAC shall issue a TMC-CONFIGURE indication primitive for the current channel in order to indicate that the physical resource has been lost.

If the MS is already receiving the allocated channel then any advanced links on that channel are unaffected and the endpoint identifier is unchanged.

After obeying a channel allocation command then, if the MS is not capable of receiving all concurrent channels as well as the newly allocated channel, the MS-MAC shall issue a TMC-CONFIGURE indication primitive to the higher layers for those channels that it can no longer receive in order to indicate that the physical resource on those channels is lost.

After a channel change, the MS-MAC shall inform the MLE about the channel now in use using the TMC-SELECT indication primitive.

NOTE 5: For allocation type 01<sub>2</sub> (Add) or 11<sub>2</sub> (Replace + CSS channel), the MS-MAC may need to allocate additional endpoint identifiers, in a similar manner to that described in clause 23.5.4.2.2.

NOTE 6: As indicated in clause 23.3.4, it is possible that an MS may receive concurrent independent channel allocations for the uplink and downlink of the same channel. If the BS has sent channel allocations that have assigned the uplink and downlink independently to the same MS (e.g. both on the MS's individual address, or one on the MS's individual address and the other on one of the MS's valid group addresses) then the BS should include a higher layer message when it sends a "replace" or "replace + CSS channel" command on that channel, thus enabling the MS to deduce which channel allocation is being replaced. This applies also for a "quit" command.

NOTE 7: When the BS sends an additional channel allocation (allocation type 01<sub>2</sub>) on an assigned channel, it should include a higher layer message indicating the intended usage of the channel allocation; even if only an LLC acknowledgement is included with the channel allocation, this may enable the MS to deduce the intended usage.

#### 23.5.4.2.4 Reception of channel allocation on CSS channel

If the MS receives a channel allocation on a CSS channel for one of its valid addresses or for a corresponding event label, then the "allocation type" may take any of the four values.

- a) For allocation type 00<sub>2</sub> (Replace) or 11<sub>2</sub> (Replace + CSS channel), the MS-MAC shall set the "channel change response required" parameter in the TMA-UNITDATA indication primitive to "true" (and shall include a channel change handle). If the decision is delayed for a group addressed channel allocation then the MS-MAC may continue to use the CSS channel in the interim time.

If the higher layers return a TMC-CONFIGURE request primitive containing the "channel change accepted" parameter set to "reject" or "ignore" then the MS-MAC shall ignore the channel allocation and may continue to use the CSS channel. The MS may use any subslot or slot(s) that are granted on the CSS channel but shall ignore a slot grant if element "position of grant" in the channel allocation PDU indicated the allocated channel.

If the higher layers return a TMC-CONFIGURE request primitive containing the "channel change accepted" parameter set to "accept" then the MS-MAC shall obey the channel allocation command. If "allocation type" = 11<sub>2</sub> in a channel allocation indicating the current carrier then the MS may continue to use the CSS channel. However, if either:

- 1) "allocation type" = 00<sub>2</sub>; or
- 2) "allocation type" = 11<sub>2</sub> in a channel allocation directing the MS to another carrier;

then the MS shall not continue to use the CSS channel on the current carrier though, in case 2), it may use the common or CSS channel on the new carrier.

- b) For allocation type 01<sub>2</sub> (Add), the MS-MAC shall set the "channel change response required" parameter in the TMA-UNITDATA indication primitive to "true" (and shall include a channel change handle). If the decision is delayed for a group addressed channel allocation then the MS-MAC may continue to use the CSS channel in the interim time.

If the higher layers return a TMC-CONFIGURE request primitive containing the "channel change accepted" parameter set to "reject" or "ignore" then the MS-MAC shall ignore the channel allocation and may continue to use the CSS channel. The MS may use any subslot or slot(s) that are granted on the CSS channel but shall ignore a slot grant if element "position of grant" in the channel allocation PDU indicated the allocated channel.

If the higher layers return a TMC-CONFIGURE request primitive containing the "channel change accepted" parameter set to "accept" then the MS-MAC shall obey the channel allocation command. It may also continue to use the CSS channel if it is capable of doing so.

- c) For allocation type 10<sub>2</sub> (Quit), the appropriate procedure shall apply as follows:
- 1) If a TM-SDU was not included within the PDU that allocated the channel and the MS would still be able to receive its current assigned channel(s) after moving to the allocated channel and the MS is capable of using the allocated channel then the MS-MAC shall obey the channel allocation. It shall cease to receive the CSS channel using the timing for an immediate decision and shall move to the allocated channel.
  - 2) If a TM-SDU was not included within the PDU that allocated the channel, and either the MS would be unable to receive its current assigned channel(s) after moving to the allocated channel (e.g. if the channel allocation is directing the MS to the common control channel and the MS is not capable of concurrent multi-carrier operation) or the MS is not capable of using the allocated channel, then the MS-MAC shall cease to receive the CSS channel using the timing for an immediate decision but shall not move to the allocated channel.
  - 3) If a TM-SDU was included within the PDU that allocated the channel then the MS-MAC shall set the "channel change response required" parameter in the TMA-UNITDATA indication primitive to "true" (and shall include a channel change handle). The MS-MAC shall then wait for a response from the higher layers:
    - if the higher layers return a TMC-CONFIGURE request primitive containing the "channel change accepted" parameter set to "accept" then the MS-MAC shall obey the channel allocation. The MS shall cease to receive the CSS channel and shall move to the allocated channel;
    - if the higher layers return a TMC-CONFIGURE request primitive containing the "channel change accepted" parameter set to "reject" then the MS shall cease to receive the CSS channel. The MS may use any subslot or slot(s) that are granted on the CSS channel but shall ignore a slot grant if element "position of grant" in the channel allocation PDU indicated the allocated channel;
    - if the higher layers return a TMC-CONFIGURE request primitive containing the "channel change accepted" parameter set to "ignore" then the MS-MAC shall ignore the channel allocation and may continue to use the CSS channel. The MS may use any subslot or slot(s) that are granted on the CSS channel but shall ignore a slot grant if element "position of grant" in the channel allocation PDU indicated the allocated channel;
    - If the higher layers do not return a TMC-CONFIGURE request primitive containing the "channel change accepted" parameter within a time T<sub>216</sub> following receipt of the channel allocation then the MS shall cease to receive the CSS channel. If the higher layers later return a TMC-CONFIGURE request primitive containing the "channel change accepted" parameter set to "accept" then the MS should start to receive the allocated channel.

If the MS ceases to receive the CSS channel, the MS-MAC shall issue a TMC-CONFIGURE indication primitive for the CSS channel in order to indicate that the physical resource has been lost.

If the MS is already receiving the allocated channel then any advanced links on that channel are unaffected and the endpoint identifier is unchanged.

NOTE 1: In the case of a channel allocation with a slot grant on the CSS channel, when the above procedures refer to the MS ceasing to receive the CSS channel, the MS should not leave the channel until after the end of the last uplink slot granted by that PDU (or the end of the slot containing a granted subslot).

After obeying a channel allocation command then, if the MS is not capable of receiving all concurrent channels as well as the newly allocated channel, the MS-MAC shall issue a TMC-CONFIGURE indication primitive to the higher layers for those channels that it can no longer receive in order to indicate that the physical resource on those channels is lost.

After a channel change, the MS-MAC shall inform the MLE about the channel now in use using the TMC-SELECT indication primitive.

NOTE 2: For allocation type 01<sub>2</sub> (Add) or 11<sub>2</sub> (Replace + CSS channel), the MS-MAC may need to allocate additional endpoint identifiers, in a similar manner to that described in clause 23.5.4.2.2.

NOTE 3: When the BS sends a channel allocation on a CSS channel, it should include a higher layer message indicating the intended usage of the channel allocation except in some cases of allocation type 10<sub>2</sub> (Quit). Even if only an LLC acknowledgement is included with the channel allocation, this may enable the MS to deduce the intended usage.

### 23.5.4.3 Channel change

#### 23.5.4.3.1 Timing of channel change

When the MS-MAC obeys a channel allocation command, it shall inform the lower layers of any change of RF carrier and/or timeslot(s). The carrier information is contained in the "channel allocation" element (see clause 21).

For a change of carrier within the cell, the MS shall assume that the current frame and slot synchronization apply also on the new carrier.

When directed to a new cell, the MS-MAC shall assume the frame and slot synchronization from the SYNC and SYSINFO PDUs most recently received while scanning the main carrier of that cell (see clause 23.7). On receiving the TMC-SELECT indication primitive for a cell change channel allocation, the MLE returns a TMC-SELECT response primitive indicating the main carrier of the new cell, enabling the MAC to reference the correct information.

If a "slot granting" element is included in the same PDU as the channel allocation element then:

- if element "position of grant" in the PDU indicates "Current Channel", the MS shall obey the procedure for use of reserved slots (see clause 23.5.2) on the current channel;
- otherwise the MS shall assume that the slot grant is on the allocated channel.

NOTE 1: If the MS does not obey the channel allocation, it may use any subslot or slot(s) that are granted on the current channel but ignores a slot grant if element "position of grant" in the PDU indicates the allocated channel.

The timing of the move to an allocated channel shall be as follows:

- 1) If the MS obeys an individually addressed channel allocation, or if it makes an immediate decision to obey a group addressed channel allocation, then the first uplink (respectively downlink) slot on the allocated channel shall be defined relative to either:
  - a) the end of the downlink slot containing the channel allocation; or
  - b) in the case of a channel allocation with a slot grant on the current channel (with "granting delay" ≠ 1111<sub>2</sub>):
    - the end of the last uplink slot granted by that PDU (or the end of the slot containing a granted subslot); or

- c) if the current channel is a multi-slot channel, and the next immediate uplink slot following the channel allocation is part of the current channel, and the MS is transmitting traffic in that slot or was previously granted that slot (or a subslot in that slot) for reserved access:

- the end of that next immediate uplink slot;

whichever is the later. Then, after one timeslot duration, the first uplink (respectively downlink) slot on the allocated channel shall be defined as the next uplink (respectively downlink) slot that corresponds to one of the timeslots indicated by element "timeslot assigned". This timing rule shall apply both for allocation within the same cell and for a different cell.

For a slot grant on the allocated channel, granting delay = 0000<sub>2</sub> in the "slot granting" element shall refer to the use of the first uplink slot on the allocated channel. Granting delay > 0000<sub>2</sub> shall then refer to delaying by the specified number of delay opportunities on the allocated channel as defined by element "timeslot assigned".

NOTE 2: Condition c) above applies only to a frequency full duplex or fast switching MS. It assumes that the MS cannot stop transmission immediately and should not stop in the middle of a full slot. For example, if the MS is transmitting traffic and receives a channel allocation sent in downlink slot 1, the MS should continue to transmit in the immediately following uplink slot 4 (if that is a valid traffic slot), before moving to the allocated channel.

NOTE 3: The following are examples of the channel timing, for allocation within the same cell.

- i) For a channel allocation sent in slot 1, assigning timeslot 1, e.g. on another RF carrier:
  - the first uplink slot on the allocated channel is the uplink slot 1 of the same TDMA frame;
  - the first downlink slot on the allocated channel is the downlink slot 1 of the next TDMA frame.
- ii) For a channel allocation sent in slot 1, assigning timeslot 2:
  - the first uplink slot on the allocated channel is the uplink slot 2 of the same TDMA frame;
  - the first downlink slot on the allocated channel is the downlink slot 2 of the next TDMA frame.
- iii) For a channel allocation sent in slot 1, assigning timeslot 4:
  - the first downlink (respectively uplink) slot on the allocated channel is the downlink (respectively uplink) slot 4 of the same TDMA frame (i.e. frame number X where the channel allocation was sent in slot 1 of frame X).
- iv) For a channel allocation sent in slot 1, with a single subslot grant on the current channel in that TDMA frame, and assigning timeslot 2:
  - the first downlink (respectively uplink) slot on the allocated channel is the downlink (respectively uplink) slot 2 of the next TDMA frame.
- v) For a channel allocation sent in slot 1, with a single subslot grant on the current channel in that TDMA frame, and assigning timeslot 3:
  - the first uplink slot on the allocated channel is the uplink slot 3 of the same TDMA frame;
  - the first downlink slot on the allocated channel is the downlink slot 3 of the next TDMA frame.



- vi) For a channel allocation sent in slot 1, with a single subslot grant on the current channel in that TDMA frame, and assigning timeslots 1 and 4:
  - the first uplink slot on the allocated channel is the uplink slot 4 of the same TDMA frame;
  - the first downlink slot on the allocated channel is the downlink slot 1 of the next TDMA frame.
- vii) If a frequency full duplex or fast switching MS is transmitting traffic on a multi-slot channel comprising timeslots 1, 2 and 3, and receives a channel allocation sent in slot 2 of a frame in the range 1 to 17, replacing the current channel with timeslots 2, 3 and 4, then the MS continues to transmit traffic in uplink slot 1 before it switches channel. Then:
  - the first uplink slot on the allocated channel is the uplink slot 3 of the same TDMA frame;
  - the first downlink slot on the allocated channel is the downlink slot 2 of the next TDMA frame.

For allocation on a different cell, the MS still allows one timeslot duration (approximately 14,17 ms). Then the first uplink (respectively downlink) slot on the allocated channel on the new cell is the next uplink (respectively downlink) slot that corresponds to one of the timeslots indicated by element "timeslot assigned" - using the new cell synchronization. This timing applies whether the new cell is synchronized to the current cell or not. The normal rules for slot grants and CLCH permission then apply on the allocated channel.

NOTE 4: Element "position of grant" is included to allow flexibility of channel scheduling by the BS. For example, if there is already traffic on the uplink of the allocated channel, the BS may wish to grant a subslot on the current channel for a layer 2 acknowledgement from an MS that is to receive traffic, e.g. in case of independent allocation of uplink and downlink. In other cases, granting on the allocated channel may often be more appropriate.

When using the layer 2 acknowledged service, the BS should grant a subslot on the current channel for the layer 2 acknowledgement from the MS when sending a channel allocation that the MS may choose to "reject". This is because, if the BS granted a subslot on the allocated channel and the MS did not move to the allocated channel, then the MS could not use the granted subslot on the allocated channel for the layer 2 acknowledgement.

- 2) If the MS decides to obey a group addressed channel allocation after a delay then the first uplink (respectively downlink) slot on the allocated channel shall be defined either relative to the time when the MS-MAC receives the TMC-CONFIGURE request primitive accepting the channel allocation or relative to the end of the slot in which the MS-MAC received the TMC-CONFIGURE request primitive. Then, after one timeslot duration, the first uplink (respectively downlink) slot on the allocated channel shall be defined as the next uplink (respectively downlink) slot that corresponds to one of the timeslots indicated by element "timeslot assigned". This timing rule shall apply both for allocation within the same cell and for a different cell.

For a slot grant on the allocated channel, the granting delay is defined relative to the first uplink slot on the allocated channel for an immediate decision (as specified in procedure 1) above). Therefore, in the case of a delayed decision, the MS-MAC shall not use the granted capacity unless it is capable of calculating the intended time of the granted capacity based on an immediate decision and the higher layers accept the channel allocation before that time occurs. If the MS-MAC does not use the granted capacity then, since uplink messages with a group address in the MAC header are only ever sent by reserved access, the MS should discard the uplink message intended to be sent in the granted capacity.

EXAMPLE: For example, in an implementation, the MS-MAC could issue a MAC-READY signal for the group address and receive the TMA-UNITDATA request but then report failure to send the message.

Uplink messages with the group address in the MAC header are used only for the low-level group presence indication.

Slot granting is valid only on the channel on which the grant was made, except in the case of slots granted in the same PDU as a channel allocation and with element "position of grant" indicating the allocated channel. Therefore, after an MS has obeyed a channel allocation command then, if it is no longer using the channel on which the channel allocation was received, any slot grants received on the old channel before the channel allocation shall cease to be valid.

As defined in clauses 23.4.2.1 and 23.4.3.1, fragmentation and reconstruction apply to a specific control channel. Therefore, after an MS has obeyed a channel allocation command then, if it is no longer using the channel on which the channel allocation was received, it shall discontinue any ongoing uplink fragmentation on the old channel (reporting to the LLC that the transmission has failed) and shall also discard any partially reconstructed downlink TM-SDU.

#### 23.5.4.3.2 Use of "timeslot assigned"

If the "timeslot assigned" element  $\neq 0000_2$ , the MS-MAC shall see note that the channel is an assigned channel, assigned for SCCH or for a circuit mode call. If the "timeslot assigned" element =  $0000_2$ , the MS shall go to the appropriate common control channel as indicated by the last received SYSINFO PDU.

An assigned channel may comprise one or more timeslots per TDMA frame, as indicated by the bit map in element "timeslot assigned".

For "allocation type" =  $11_2$  (i.e. Replace + CSS channel), the "timeslot assigned" element shall indicate only those slots belonging to the assigned channel. Thus, if the specified carrier is not the main carrier, the first bit in the bit map shall be 0 (bit map =  $0xxx_2$ ); the use of slot 1 for the CSS channel is implicit. If the specified carrier is the main carrier, the bit corresponding to the common channel shall be 0.

**NOTE:** The designation of whether the MS-MAC regards the channel as "assigned" or "common" affects the random access and channel maintenance procedures.

If the BS assigns slot 1 of the main carrier for a circuit mode call, it should send a channel allocation command to those users. This does not cause a change of carrier or timeslot; but it is needed to change the MAC mode from "common" to "assigned", and also to define monitoring pattern information and a traffic usage marker. A similar procedure applies if the BS wishes to allow an MS that is receiving a CSS channel to use slot 1 of that carrier for a circuit mode call or as a fully assigned SCCH.

#### 23.5.4.3.3 Use of "up/downlink assigned"

The MS-MAC shall see note, from element "Up/downlink assigned", whether either or both directions on the allocated channel have been assigned exclusively for the usage required by the MS.

This information generally affects only the channel maintenance procedure.

**EXAMPLE:** For example, in the case of independent allocation of uplink and downlink for different purposes, reduced procedures shall apply; see clause 23.5.6.

However, for the application of the general procedures for transmission and reception of signalling messages, each control channel (ACCH or SCCH) shall be assumed to occupy any control slots on both the downlink and uplink directions, as indicated by element "timeslot assigned".

**EXAMPLE:** For example, the MS monitors the downlink channel according to the normal procedures for an assigned channel, even if only the uplink was allocated by element "Up/downlink assigned". Similarly, the normal procedures for random access and reserved access on an assigned channel apply, even if only the downlink was allocated by element "Up/downlink assigned".

**NOTE 1:** Element "Up/downlink assigned" is included to allow the BS to use independent allocation of uplink and downlink i.e. allocating the uplink and downlink channels for different purposes (as described in clause 23.3.4).

**NOTE 2:** For "allocation type" =  $11_2$ , the "Up/downlink assigned" designation applies only to the assigned channel. Allocation of only one direction of a CSS channel does not apply.

#### 23.5.4.3.4 CLCH permission

If the "CLCH permission" flag indicates "Immediate CLCH permission" and the MS makes an immediate decision to accept the channel allocation then the MS may use the first subslot of the first uplink slot on the allocated channel for linearization, without needing to receive the corresponding ACCESS-ASSIGN PDU. The first uplink slot on the allocated channel is as defined in procedure 1) of clause 23.5.4.3.1 i.e. as defined for an immediate decision.

Otherwise, if the MS requires to use CLCH for linearization, it shall wait for an appropriate frame 18 or for an ACCESS-ASSIGN PDU indicating a linearization subslot.

NOTE 1: The "CLCH permission" flag is included to allow for fast call set-up with a change of RF carrier while still allowing flexibility for the BS, e.g. in cases of independent allocation of uplink and downlink or repeat set-up signalling for a group call. The BS should at least give CLCH permission to any MSs that need to use CLCH for linearization and that are granted slots and/or given transmit permission on a new carrier. The CLCH permission applies to any MS that obeys the channel allocation message without delay, whether or not it has been granted slots and/or transmits permission.

NOTE 2: For "allocation type" = 11<sub>2</sub>, the CLCH permission applies only to the assigned channel, not to the CSS channel.

NOTE 3: In the case of a delayed decision to accept a group addressed channel allocation, the MS may use the CLCH permission if it is capable of calculating the time of the first uplink slot of the allocated channel based on an immediate decision and the higher layers accept the channel allocation before that time occurs.

#### 23.5.4.3.5 Monitoring pattern information

The MS shall see note the monitoring pattern information in case it is required to transmit user traffic on this channel. This requirement to store the monitoring pattern information applies to any MS that obeys the channel allocation message, whether or not it has been given permission to transmit user traffic at this time.

The monitoring pattern information indicates in which downlink frames the MS is required to receive downlink slots and attempt to decode any signalling messages (within the capabilities of that MS) while it is transmitting traffic. This enables the BS to send signalling messages to that MS during its traffic transmission. See clause 9 for the definition of the usage of the monitoring pattern numbers; see also clause 21.5.2.

In the case that no monitoring pattern is assigned, an additional field defines the multiframes in which the MS shall monitor the downlink assigned slot in frame 18 (or, for a multi-slot channel, at least the highest numbered downlink slot of the assigned channel in frame 18).

The requirements for the MS to adhere to the assigned monitoring pattern(s) are only within the capabilities of that MS. The BS should see note those capabilities when sending signalling messages to an MS that is transmitting traffic on a multi-slot channel (see clauses 23.3.1.3 and 23.3.1.4).

NOTE 1: When the BS allocates a multi-slot channel to a frequency half duplex MS, it is not precluded from assigning monitoring pattern(s) that the MS cannot observe. For example, this may be convenient if the BS assigns the monitoring pattern information in a group addressed channel allocation, where the group contains both frequency full duplex and frequency half duplex MSs. However the BS should be aware that a frequency half duplex MS without fast switching capability is not able to receive signalling on the downlink between transmitted bursts on the uplink.

NOTE 2: The monitoring pattern information refers to the requirements on an MS that is transmitting traffic to receive the downlink of the current channel. This is not the same as the "monitoring procedure" defined in clause 23.7.4, in which the MS measures the signal strength of adjacent cells and calculates C2.

NOTE 3: The BS designer should see note that the assignment of all three monitoring patterns to a frequency half duplex MS in a simplex call may reduce that MS's ability to perform cell reselection measurements on adjacent cells while it is transmitting traffic. The BS designer should also see note that the assignment of all three monitoring patterns to a frequency half duplex dual watching MS may reduce that MS's ability to perform dual watch on the Direct Mode RF carrier during V+D calls.

NOTE 4: For "allocation type" = 11<sub>2</sub>, the monitoring pattern information applies only to the assigned channel, not to the CSS channel.

### 23.5.5 Usage marker assignment

A traffic usage marker is a 6-bit MAC label used during circuit mode calls for transmitter pre-emption, for prevention of crossed calls and for channel maintenance purposes. The BS shall assign a traffic usage marker before any traffic transmission takes place on an assigned channel.

It shall assign the usage marker with a message that contains also a channel allocation command directing MS(s) to an assigned channel. The usage marker assignment shall be valid for that MS (or those MSs) only on that assigned channel. So, for example, for message trunking, one traffic usage marker generally applies for the complete call and the same usage marker should be assigned for all participants in that call on that assigned channel; whereas, for transmission trunking, the BS should assign a traffic usage marker for each "over".

NOTE 1: If the BS wishes to assign a traffic usage marker on an already assigned channel, then it may use the "replace channel" command indicating the current channel. However, when the BS uses a group addressed message to allocate a channel for a circuit mode call, it is recommended that, if possible, it assigns the traffic usage marker when it sends the channel allocation; otherwise the usage marker may not be received by those MSs that do not make an immediate decision to accept the channel allocation.

NOTE 2: For "allocation type" = 11<sub>2</sub>, the usage marker applies only to the assigned channel, not to the CSS channel.

When there is traffic (TCH or STCH) on either the uplink or the downlink, the BS shall use the appropriate traffic usage marker in the ACCESS-ASSIGN PDU sent on the AACH in frames 1 to 17 on the downlink assigned channel to confirm permission to transmit and/or receive traffic. For uplink traffic, Header 11<sub>2</sub> shall be used, with "Field 2" set to the uplink traffic usage marker. For downlink traffic, Header 01<sub>2</sub>, 10<sub>2</sub> or 11<sub>2</sub> shall be used, with "Field 1" set to the downlink traffic usage marker.

A traffic usage marker may also be sent in the ACCESS-ASSIGN PDU in frame 18, though frame 18 is never used for TCH or STCH. Then the frame 18 Header shall be set to 11<sub>2</sub> and the usage marker in "Field 1" may be set to either the uplink or downlink traffic usage marker as appropriate. This can be useful for channel maintenance purposes. And, during uplink traffic, it should be used with the traffic usage marker of the transmitting MS if the BS has not assigned a monitoring pattern for frames 1 to 17 (or, for a multi-slot channel, if the BS has assigned monitoring pattern(s) that the MS may not be capable of following in any slots in frames 2 - 17).

The procedures for channel maintenance by the MS-MAC, and the criteria for MS transmission and reception of traffic, are described in clauses 23.5.6 and 23.8.2 respectively.

When the BS wishes to assign a traffic usage marker, it shall use the MAC-RESOURCE PDU, which shall contain "Address Type" = 110<sub>2</sub> and the assigned traffic usage marker. The "channel allocation" element shall be included in that MAC-RESOURCE PDU or in the associated MAC-END PDU. If the MS-MAC receives a usage marker assignment without the corresponding channel allocation (e.g. in the case of fragmentation if the MS does not receive the MAC-END PDU), or if it does not obey the channel allocation, then it shall ignore the usage marker assignment.

A traffic usage marker shall apply for the direction(s) specified in the channel allocation, i.e. the appropriate direction for element "Up/downlink Assigned" = 01<sub>2</sub> or 10<sub>2</sub>, or both directions for element "Up/downlink Assigned" = 11<sub>2</sub>. If the BS uses independent allocation of the uplink and downlink for two circuit mode calls then the traffic usage marker should be different for the two directions.

In the case of independent allocation of the uplink and downlink of a channel for concurrent calls involving the same MS, the MS-MAC may receive independent channel allocations of uplink and downlink, each with a usage marker assignment. Each usage marker shall apply independently for the specified direction. (However, the same endpoint identifier applies for both allocations when the allocations are for the same assigned channel.)

The MS-MAC shall consider that an assigned traffic usage marker is valid until:

- i) it leaves the assigned channel (or returns to common mode on this channel); or
- ii) it receives another traffic usage marker with a channel allocation for the same direction(s) or for both directions on the same assigned channel; or
- iii) it receives a channel allocation for the same direction(s) or for both directions on the same assigned channel, but without a usage marker assignment.

The BS is responsible for deciding when a traffic usage marker may safely be re-used for a subsequent call on the same physical channel.

## 23.5.6 Maintenance of assigned channel

The MS shall receive the MCCH, or the appropriate common SCCH, unless directed by the BS to an assigned channel. An assigned channel may be intended for secondary control purposes or for a circuit mode call. The MS shall assume that the assigned channel is intended for secondary control unless it has received a traffic usage marker for use on the channel.

The ACCH is the control channel associated with an assigned traffic channel. When ACCH is present, its usage is similar to the usage of assigned SCCH, and there is no distinction in the pre-set usage marker designation in the AACH. Both types of control channel shall be regarded as assigned control channel. The traffic usage marker is generally used only while the channel is carrying user traffic TCH or STCH.

The procedures for channel maintenance defined in clause 23.5.6.1 apply on either type of assigned channel, unless specified otherwise.

The procedures for maintenance of a CSS channel are reduced compared with those for a normal assigned channel. They are defined in clause 23.5.6.2.

### 23.5.6.1 Criteria for leaving assigned channel

The MS-MAC shall continue to receive and attempt to decode signalling on the downlink assigned channel as defined by element "timeslot assigned" (within the constraints of the cell reselection procedures and monitoring pattern requirements, and linearization and transmission requirements) until one of the following occurs:

- the MS-MAC obeys a channel allocation command from the BS, directing it elsewhere (see clause 23.5.4); or
- the MS is required to leave the channel by one of the channel maintenance procedures in clauses 23.5.6.1.1 and 23.5.6.1.2; or
- the MS-MAC receives a TMC-SELECT request primitive from the higher layers instructing it to leave the assigned channel; or
- the MS-MAC receives a TMC-CONFIGURE request primitive from the higher layers indicating call release for this channel, e.g. the user wishes to leave a group call.

In the last case, the MS should not leave the channel if it has been assigned both directions of the channel in two independent allocations of uplink and downlink, and if the service on the other direction is still ongoing.

#### 23.5.6.1.1 Checking of AACH

The MS shall attempt to decode the AACH in slots appropriate to the downlink assigned channel as defined by element "timeslot assigned" (within the constraints of the cell reselection procedures and monitoring pattern requirements, and linearization and transmission requirements).

If N.208 successive ACCESS-ASSIGN PDUs received in frames 1 to 17 in the AACH of slots appropriate to the downlink assigned channel indicate that:

- a) the downlink is unallocated, i.e. Header  $\neq$  00<sub>2</sub> and downlink usage marker = UMx (000000<sub>2</sub>); or
- b) the channel has returned to exclusively common control use, i.e. Header = 00<sub>2</sub>; or
- c) the relevant direction(s) have been assigned for another purpose (see below),

then the MS shall regard the assigned channel as no longer valid for transmission or reception. Then, if the MS does not have a concurrent assigned channel, it shall return to the main carrier, i.e. to the MCCH or appropriate common SCCH. The MS-MAC shall inform the higher layers of the de-allocation using the TMA-RELEASE indication primitive and of any change of channel using the TMC-SELECT indication primitive.

For criterion c), the MS shall check as follows:

- If the downlink was assigned for this MS (element "Up/downlink Assigned" = 01<sub>2</sub> or 11<sub>2</sub>), the MS shall regard the assigned channel as no longer valid if:
  - for assigned SCCH:
 

the downlink is not in assigned control i.e. the channel is no longer valid if Header = 00<sub>2</sub> or if the downlink usage marker ≠ 000001<sub>2</sub>;
  - for a circuit mode call:
 

the downlink is not in assigned control nor in traffic with the MS's usage marker i.e. the channel is no longer valid if Header = 00<sub>2</sub> or if the downlink usage marker is neither 000001<sub>2</sub> nor the MS's downlink traffic usage marker.
- If the uplink was assigned for this MS (element "Up/downlink Assigned" = 10<sub>2</sub> or 11<sub>2</sub>), the MS shall regard the assigned channel as no longer valid if:
  - for assigned SCCH:
 

the uplink is unallocated or is being used for traffic i.e. the channel is no longer valid if Header = 11<sub>2</sub> and the uplink usage marker = 000000<sub>2</sub> or is ≥ 000100<sub>2</sub>;
  - for a circuit mode call:
 

the uplink is unallocated or is being used for traffic by other users i.e. the channel is no longer valid if Header = 11<sub>2</sub> and the uplink usage marker = 000000<sub>2</sub> or is ≥ 000100<sub>2</sub> and is not the MS's uplink traffic usage marker.

If the MS has been assigned both directions of the channel in two independent channel allocations then it shall not leave the channel on criterion c) unless both directions are no longer valid according to the above definition. Whereas, if the MS has been assigned both directions of the channel in a single channel allocation (i.e. with element "Up/downlink Assigned" = 11<sub>2</sub>) then it shall leave the channel on criterion c) if either direction is no longer valid.

NOTE 1: The MS should not react to reception of only one adverse ACCESS-ASSIGN PDU, because of the possibility of incorrectly decoding the AACH. So  $N.208 \geq 2$ .

NOTE 2: For this procedure, the MS checks only the designation of slots belonging to the downlink assigned channel (although, in the case of an extended random access channel, the MS may be decoding other ACCESS-ASSIGN PDUs).

NOTE 3: As a result of de-allocation on criterion b) or c), the MS may actually remain on the same physical channel. However, its designation has changed from "assigned" to "common".

NOTE 4: If the BS has assigned only the uplink in a channel allocation, and the downlink is not used for another purpose, the BS should mark the downlink as "assigned control" in the AACH, not "unallocated". Similarly, the BS should not use Header 00<sub>2</sub> unless the channel is entirely dedicated to common control usage.

### 23.5.6.1.2 Inactivity time-out

If the MS is on a channel assigned for SCCH, and a time T.208 elapses without either:

- transmission by the MS by reserved access; or
- receipt of a downlink message on this channel containing one of its valid addresses or event labels, other than the predefined broadcast group address (all ones);

then the MS shall regard the channel as no longer valid for transmission or reception.

If the MS is on a channel assigned for a circuit mode call, and a time T.209 elapses without either:

- transmission by the MS, for traffic (TCH or STCH) or by reserved access; or
- receipt of a downlink message on this channel containing one of its valid addresses or event labels, other than the predefined broadcast group address (all ones); or
- receipt of an ACCESS-ASSIGN PDU containing the MS's traffic usage marker (either as the downlink or the uplink usage marker in the ACCESS-ASSIGN PDU, and in any frame 1 to 18);

then the MS shall regard the channel as no longer valid for transmission or reception.

In case of time-out on either T.208 or T.209 then, if the MS does not have a concurrent assigned channel, it shall return to the main carrier, i.e. to the MCCH or appropriate common SCCH. The MS-MAC shall inform the higher layers of the de-allocation using the TMA-RELEASE indication primitive and of any change of channel using the TMC-SELECT indication primitive.

NOTE 1: In order to keep MSs on the channel during long periods of FACCH, e.g. for an open channel, the BS may send occasional slots in frames 1 to 17 containing the traffic usage marker as the uplink usage marker (with Header 11<sub>2</sub>); or it may use the traffic usage marker as the usage marker in frame 18 (frame 18 Header 11<sub>2</sub>). Also, use of the traffic usage marker as the downlink usage marker in occasional slots in frames 1 to 17 (with STCH + STCH) is not precluded though it is not recommended. Otherwise the BS could send dummy messages addressed to the MS(s) on the channel.

NOTE 2: If the MS decides to obey a group addressed channel allocation after a delay then it may choose to decrease its value of T.208 or T.209 until it has received signalling confirming that the expected service is still ongoing on the assigned channel i.e. until it has received an appropriate downlink message addressed to itself or ACCESS-ASSIGN PDU(s) containing its traffic usage marker. Similarly, in clause 23.5.6.1.1, the MS is not precluded from reducing its value of N.208 though it should not reduce N.208 to below 2.

### 23.5.6.2 Criteria for leaving carrier specific signalling channel

After assignment of a CSS channel, the MS-MAC may continue to use the CSS channel on that carrier until one of the following occurs:

- a) it obeys a channel allocation command received on that CSS channel, directing it elsewhere (see clause 23.5.4.2.4); or
- b) it has no assigned channel on that carrier, assigned either for SCCH or for a circuit mode call; or
- c) it obeys a channel allocation command allocating slot 1 of that carrier as an assigned channel.

The MS-MAC should inform the higher layers of the de-allocation of the CSS channel and of any change of channel.

EXAMPLE: For example, in criterion a), the MS leaves the CSS channel if it obeys a "replace" channel allocation received on the CSS channel, or if it obeys a "replace + CSS channel" allocation received on the CSS channel and assigning a different carrier, or if it receives and does not ignore a "quit" channel allocation received on the CSS channel.

Criterion b) requires the MS to leave the CSS channel when it no longer has an assigned channel (other than the CSS channel) on that carrier.

If criterion c) occurs, the MS remains on the same physical channel (i.e. slot 1 of the carrier). However, its usage of the physical channel has changed from CSS channel to assigned channel.

NOTE 1: Criterion a) only requires the MS to leave the CSS channel. It does not require the MS to leave the assigned channel that was allocated in the same channel allocation as the CSS channel (unless the MS is no longer capable of receiving that assigned channel as a result of obeying the channel allocation command).

NOTE 2: Criterion b) requires the MS to leave the CSS channel when it has no assigned channel on that carrier. Thus the permission to use the CSS channel is not specifically linked to the assigned channel that was allocated in the same channel allocation as the CSS channel. If the MS leaves that assigned channel then it may continue to use the CSS channel if it has another assigned channel on the carrier.

### 23.5.6.3 Traffic on downlink for other users

When the MS is receiving an assigned channel, the downlink may be used for traffic independently of any usage of the uplink for signalling or traffic. For example:

- uplink assigned for SCCH, but with downlink not dedicated to SCCH;
- inter-site circuit mode call.

An MS is specifically instructed when it may process received user traffic TCH for transfer to its U-plane application, as described in clause 23.8.2.

An MS that has not received such authorization shall interpret the downlink slots as follows.

The MS shall assume that a downlink slot in frames 1 to 17 is in traffic mode carrying traffic for other MSs if the AACH contains a downlink traffic usage marker (i.e. Header  $\neq 00_2$  and downlink usage marker  $\geq 000100_2$ ). Otherwise it shall assume that the downlink is in signalling mode. If the AACH cannot be decoded then the MS shall assume that the downlink is in the mode indicated by the last AACH received and successfully decoded in frames 1 to 17 in a slot appropriate to the downlink assigned channel. (See clause 19 for the configuration in signalling and traffic mode.)

In both signalling and traffic mode, full (SF= 0 ) or half slot (SF= 1 ) downlink transmissions may be used. The slot flag (SF) shall correspond to a change between two training sequences, as described in clause 9.

In the case of signalling mode:

- a) the MS shall interpret slots with SF = 0 as SCH/F;
- b) the MS shall interpret slots with SF = 1 as SCH/HD + SCH/HD.

In the case of traffic mode:

- a) the MS shall interpret slots with SF = 0 as TCH, and shall ignore that TCH;
- b) for SF = 1, the MS shall interpret the slot as STCH + TCH or STCH + STCH, depending on the content of the first STCH.

For STCH, the MS shall inspect the MAC header of each PDU in order to:

- discover whether the second half slot is stolen;
- perform PDU dissociation (in the case of C-plane stealing);
- process any C-plane messages addressed to itself.

See clause 23.8.4.2.2 for the method for reception of STCH.

The MS shall ignore the TM-SDU in any MAC-U-SIGNAL PDUs, and the TCH.

Slots containing the synchronization training sequence shall always be interpreted as BSCH + SCH/HD.

Traffic mode applies only to frames 1 to 17. Both MS and BS shall always be in signalling mode on frame 18.

NOTE 1: The above procedure applies to any MS that does not have authorization or "N.213 permission" (see clause 23.8.2.3.2) to receive TCH with this traffic usage marker. This includes an MS that is transmitting traffic in simplex mode, or an MS with a different traffic usage marker, or an MS on assigned SCCH.

NOTE 2: When the BS changes the designation of the downlink channel, it may choose to send a few slots using normal training sequence 2 (i.e. SF= 1 ), to allow for poor reception of AACH. MS interpretation of SCH/HD and two-half-slot STCH is very similar. At other times, use of SCH/F (with PDU association) is recommended for most C-plane signalling on the downlink, since it is generally more flexible.



## 23.6 PDU transfer for broadcast messages (TMB-SAP)

### 23.6.1 Broadcast channels

The BS shall transmit broadcast system information using the SYNC PDU transmitted on the BSCH and the SYSINFO PDU transmitted on the BNCH.

NOTE: The ACCESS-DEFINE PDU also contains broadcast information relating to random access and is described within clause 23.5.1.

On a traffic or control channel, the BSCH and BNCH shall be transmitted in frame 18. The BNCH may also be transmitted during frames 1 to 17 of a control channel and both BSCH and BNCH may be transmitted on unallocated channels. The precise rules for BSCH and BNCH transmission are described in clause 9.

BSCH and BNCH shall be received and decoded by all MSs camped on a cell. These broadcast PDUs contain essential system information required by the MS to synchronize with and use the facilities of the system. An MS, on receiving and correctly decoding broadcast information, shall remove the MAC header and shall store the parameters contained therein as the serving cell broadcast parameters. (While scanning adjacent cells, the MAC may also be required to store the broadcast parameters for those adjacent cells for use in the cell reselection procedures.) The MAC shall then pass the TM-SDU to the MLE. Upon receiving subsequent BSCH or BNCH PDUs, the MAC shall update its stored serving cell parameters before passing the MLE data contained in the TM-SDU to the LLC which shall then pass the MLE data transparently to the MLE. The appropriate MAC primitives are TMB-SYNC indication and TMB-SYSINFO indication.

The broadcast information in both of these PDUs relates to the system configuration for that cell. Therefore, the BSCH and BNCH information transmitted on all carriers belonging to a single cell shall be identical. This means that the MS may receive the system information on any carrier belonging to a cell. This includes slot, frame and multiframe number implying that all carriers belonging to a BS shall be synchronized in time.

### 23.6.2 Acquiring cell synchronization

An MS shall synchronize with a cell by first attempting to synchronize with the synchronization training sequence contained in the synchronization burst (BSCH). On acquiring synchronization, the MS shall then decode the contents of the SYNC PDU also contained in the synchronization burst. The SYNC PDU shall contain the colour code, which shall be used by the MS to de-scramble the contents of all other bursts transmitted by that BS, and the system code, which shall indicate whether the system is a TETRA V+D or PDO system (or whether this is a Direct Mode transmission). The SYNC PDU shall also contain the slot, frame and multiframe number for this downlink slot giving the MS full synchronization with this BS. The SYNC PDU shall also contain some information about the discontinuous mode of operation of the BS.

The MS may acquire cell synchronization on any downlink carrier being transmitted by the BS for that cell. The BSCH information shall be the same for all carriers within a cell and the slot, frame and multiframe synchronization shall be the same.

Having synchronized with a cell, the MS shall continue to decode subsequent SYNC PDUs transmitted by that BS but shall only use those with the correct colour code to prevent an MS from using the BSCH transmitted by an adjacent cell.

NOTE: There is no other co-channel interference protection on the BSCH.

The MS shall store the information received in the SYNC PDU and shall update this stored information on receiving subsequent SYNC PDUs.

### 23.6.3 Acquiring network information

An MS, having acquired cell synchronization by receiving and decoding the BSCH information, is able to decode all downlink bursts transmitted by the BS. First of all, the MS shall search for the BNCH in order to receive and decode the SYSINFO PDU containing system information for this cell. The SYSINFO PDU contains information about the frequency of the main carrier, the number of common secondary control channels in operation on the main carrier, information used for power control and cell (re-)selection and some random access parameters (see clause 21 for full description). The MAC shall decode the SYSINFO PDU and store the MAC parameters. On receiving subsequent SYSINFO PDUs, the MAC shall update these stored parameters accordingly.

Having decoded the SYNC and SYSINFO PDUs, the MS may locate the location of the MCCH (i.e. slot 1 of the main carrier) or the relevant common SCCH. The MS has all of the information needed to communicate with the BS and may now receive downlink PDUs and transmit uplink PDUs using the procedures defined elsewhere within the MAC protocol.

## 23.7 Layer management communication (TMC-SAP)

### 23.7.1 Path loss calculation

The MAC layer makes signal strength measurements both autonomously on the serving cell and under the control of the MLE layer on selected neighbouring cells. The signal strength measurements shall be passed to the MLE as an approximation of radio path loss using the path loss parameters, C1 and C2, which are defined in the following clauses.

#### 23.7.1.1 Path loss parameter C1

The MS shall calculate the path loss parameter, C1, according to the following formula:

$$C1 = \text{RSSI} - \text{RXLEV\_ACCESS\_MIN} - \text{Max} ( 0, \text{MS\_TXPWR\_MAX\_CELL} - P_{\text{MS}} ) \quad (80)$$

where:

- RSSI = averaged received signal level at MS or equivalent signal quality measurement;
- RXLEV\_ACCESS\_MIN = minimum permissible received level at MS in this cell;
- MS\_TXPWR\_MAX\_CELL = maximum MS transmit power permissible in this cell;
- $P_{\text{MS}}$  = maximum transmit power of the MS.

C1 is expressed in dB and all the other parameters in dBm.

C1 is calculated for the serving cell and for adjacent cells by scanning. RSSI, therefore, is defined in the relevant clauses for serving cell measurement (see clause 23.7.3) and scanning (see clause 23.7.5).

The cell selection parameters, RXLEV\_ACCESS\_MIN and MS\_TXPWR\_MAX\_CELL, shall be transmitted on all cells using the Broadcast Network Channel (BNCH) and shall be decoded by the MS for C1 calculation.

After synchronization has been acquired, the serving cell measurement procedure requires that C1 shall be calculated using the cell selection parameters transmitted on the serving cell. The scanning procedures also require a calculation of C1 on adjacent cells; in this case, the MS shall be synchronized to the adjacent cell and shall use the cell selection parameters transmitted on that adjacent cell in the above C1 calculation.

### 23.7.1.2 Path loss parameter C2

The MS shall calculate the path loss parameter, C2, according to the following formula:

$$C2(n) = \text{RSSI}(n) - \text{RXLEV\_ACCESS\_MIN\_MCELL}(n) - \text{Max} ( 0, \text{MS\_TXPWR\_MAX\_MCELL}(n) - P_{\text{MS}} ) \quad (81)$$

where:

- $\text{RSSI}(n)$  = averaged received signal level at MS or equivalent signal quality measurement;
- $\text{RXLEV\_ACCESS\_MIN\_MCELL}(n)$  = minimum permissible received level at MS;
- $\text{MS\_TXPWR\_MAX\_MCELL}(n)$  = maximum MS transmit power allowed in the cell;
- $P_{\text{MS}}$  = maximum transmit power of the MS.

C2 is expressed in dB and all the other parameters in dBm. (n) indicates the n<sup>th</sup> adjacent cell carrier.

C2 is calculated for adjacent cells by monitoring. RSSI, therefore, is defined in the relevant clause for monitoring (see clause 23.7.4).

The parameters,  $\text{RXLEV\_ACCESS\_MIN\_MCELL}(n)$  and  $\text{MS\_TXPWR\_MAX\_MCELL}(n)$ , which are the cell selection parameters for the adjacent cells, shall be transmitted in the serving cell using an MLE broadcast message on the relevant common control channel (main and/or secondary).

In the case where these parameters are not known by the serving cell or where the MS has not received them on the serving cell, the MS shall use the cell selection parameters for the serving cell as default values. These are broadcast on the serving cell BNCH.

### 23.7.2 Cell selection

The MLE may instruct the MAC to select a cell, as shown in figure 146, using the TMC-SELECT request primitive which shall contain a channel number parameter corresponding to a frequency. The MAC shall then instruct the physical layer to tune to that frequency for reception. As soon as the MS MAC has acquired synchronization on that carrier and decoded the BSCH and BNCH for that cell, it shall confirm the cell selection, by sending a TMC-SELECT confirm primitive to the MLE, and begin the serving cell measurements described in the following clause. If the TMC-SELECT request is to inform the MAC of a change to a cell which the MAC has previously been scanning, the MS MAC may already have acquired synchronization on the new cell and decoded the BSCH and BNCH contents, in which case it may respond with TMC-SELECT confirm as soon as the physical layer has changed frequency.

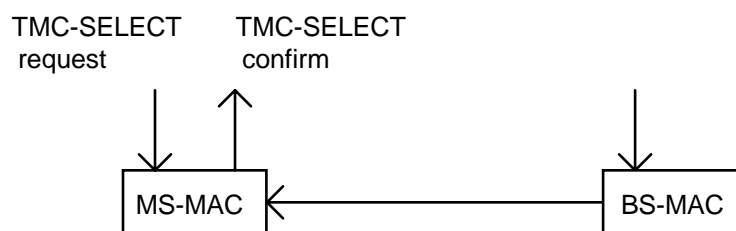


Figure 146: Cell selection

This procedure is identical in the MAC for initial cell selection and cell reselection.

### 23.7.3 Serving cell measurement

Having selected and acquired synchronization on a cell as described in the previous clause, the MAC shall begin measurement of the serving cell downlink RSSI, as defined in the following clause, and use this to calculate C1 for the serving cell (see clause 23.7.1.1). It shall then periodically report C1 to the MLE using a TMC-MEASUREMENT indication primitive as illustrated in figure 147. This measurement of the serving cell downlink RSSI and calculation of C1 is known as surveillance and shall be based upon the cell selection parameters decoded on the serving cell.

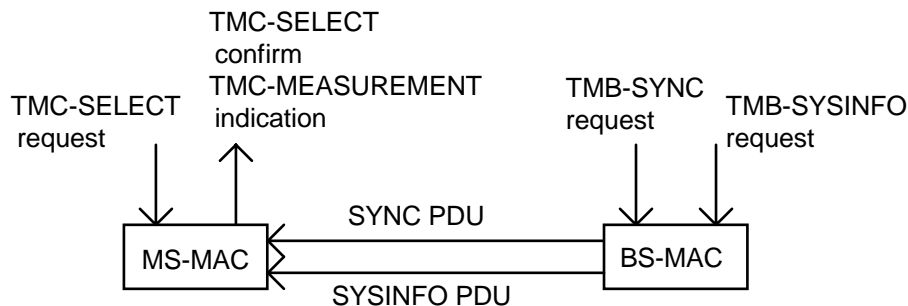


Figure 147: Cell selection and surveillance scenario

#### 23.7.3.1 Downlink measurements

The MAC shall continuously perform the measurements described in this clause on the physical channel(s) to which the MS is attached on the serving cell. Measurements shall be made on all downlink timeslots which the MAC is able to monitor within the constraints of its energy economy or dual watch mode and linearization and transmission requirements, or according to the monitoring pattern requirements for traffic transmission on an assigned channel.

The MAC shall measure the received RF signal strength or make an equivalent signal quality measurement and calculate a running average of at least 5 measurement samples.

These samples shall be taken during at least the last 5 s and at most the last 60 s. If less than 5 measurements were collected during this period, for example due to the constraints of an energy economy or dual watch mode, then the last 5 measurements may be used. The measurement sample duration shall be at least SD1 (see clause 10). If the BS operates in MCCH sharing, the measurements shall be performed only on the frames reserved for the BS, and not on the common frames (see clause 9). Based upon these measurements, the path loss parameter C1 shall be calculated by the MAC at least every 5 s for the serving cell.

The quality of the radio downlink shall be estimated from the success rate of decoding the AACH for a MS in idle mode. The MAC shall perform the following measurements to ensure the path loss to the serving cell is acceptable. The criterion for relinquishing the radio downlink is based on the Radio Downlink Counter (RDC). When the MAC first acquires cell synchronization and begins to monitor the downlink of a common control channel, RDC shall be initialized to a value equal to RADIO\_DOWNLINK\_TIMEOUT. The RADIO\_DOWNLINK\_TIMEOUT parameter is broadcast on the BNCH.

If the MAC is unable to decode an AACH message, RDC shall be decreased by  $N \times N.210$ . ( $N.210$  is a constant which defines the quality threshold for the MS.) In the case of a successful reception of an AACH message, RDC shall be increased by  $N$  but shall not be increased above the value of RADIO\_DOWNLINK\_TIMEOUT.

The parameter  $N$  is equal to the number of timeslots between successive downlink slots which the MS is attempting to receive and decode (except if the BS operates in MCCH sharing, see note 2); therefore,  $N$  is dependent on the MS mode of operation. Some examples are listed below.

- a) MS in normal mode:

In this mode, the MS is monitoring the MCCH or a common SCCH and so listens to one slot per TDMA frame. Therefore, in this case,  $N = 4$ .

- b) MS in an energy economy or dual watch mode:

In this mode, the MS is not monitoring all downlink slots of the common control channel.

**EXAMPLE:** For example, an MS operating with an energy group, EG5, may only be decoding one downlink slot per multiframe. In this case,  $N = 72$ .

c) MS receiving on an assigned channel:

In this mode, the MS is receiving one or more timeslots per TDMA frame depending upon the number of slots assigned to that channel. In this case,  $N = 4 /$  number of timeslots per TDMA frame assigned to that channel on the downlink.

d) MS transmitting traffic on a single-slot assigned channel:

In this mode, the MS is transmitting on the uplink and monitoring the downlink according to the monitoring pattern(s) given at channel assignment. In this case,  $N = 12 /$  number of monitoring patterns allocated to the MS. This applies when 1, 2 or 3 monitoring patterns are assigned.

When the mode of operation of the MS is changed, the corresponding value of  $N$  shall be calculated by the MAC and used for updating RDC. RDC is valid for the cell, whatever the RF channel on which the MS decodes the AACH.

Radio downlink failure shall be declared when the RDC falls below 0. If this happens, the MAC shall inform the MLE that radio downlink failure has occurred using a TMC-REPORT indication.

**NOTE 1:** N.210 controls the AACH message error rate threshold at which radio downlink failure occurs. For example, if  $N.210 = 4$ , the ratio 4 to 1 between failure and success counting gives a decreasing RDC when the message error rate exceeds 20 %. Therefore, a continuing message error rate greater than 20 % will cause radio downlink time-out in this case.

**NOTE 2:** If the BS operates in MCCH sharing, the MS uses only the frames reserved for the BS to update RDC (though it attempts to receive and decode the relevant slot also in the common frames). Therefore, in this case, for an MS in normal mode,  $N = 144 /$  number of reserved frames per two multiframes for the BS.

### 23.7.3.2 Uplink measurements

The criterion for determining the relinquishment of the radio uplink in the BS may be based upon uplink received signal strength measurement or an equivalent signal quality measurement and a measurement of the path delay from MS to BS derived from the time at which uplink slots are received at the BS.

The measurement of uplink received signal strength or quality may be used by the BS as a criterion to relinquish the radio link. The BS may inform the MS if this happens by sending a MAC-RESOURCE PDU which includes the optional "Power control" element with a value set to "Radio uplink failure". On receiving this, the MS MAC shall inform the MLE using a TMC-REPORT indication in order to initiate the MLE cell reselection procedures.

The measurement of uplink path delay may also be used by the BS as a criterion to relinquish the radio link. This allows the BS to limit the MS-BS distance and prevent the MS grossly exceeding the planned cell boundaries. The BS may inform the MS if this happens by sending a MAC-RESOURCE PDU which includes the optional "Power control" element with a value set to "Maximum path delay exceeded". On receiving this, the MS MAC shall inform the MLE using a TMC-REPORT indication in order to initiate the MLE cell reselection procedures.

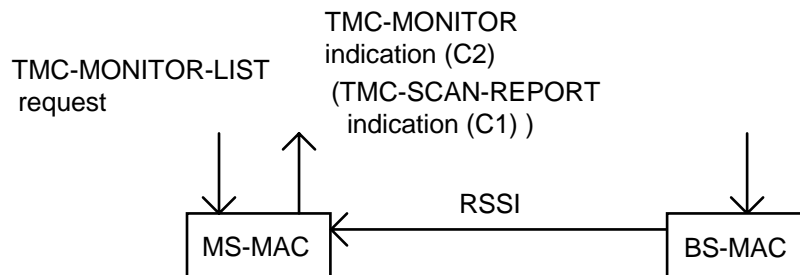
### 23.7.4 Monitoring

Monitoring is an MS function which measures the signal strength of the adjacent cells and calculates C2. The cell selection parameters for the adjacent cell are broadcast on the serving cell for the C2 calculation. Monitoring is used when the MS is not synchronized to the adjacent cells and so cannot decode the adjacent cell BNCH.

The following clause describes the monitoring procedure. The MS MAC shall perform the measurements and fulfil the requirements of providing the C2 parameter to the MLE in a way which is equivalent to or better than the method described.

### 23.7.4.1 Monitoring scenario

Figure 148 illustrates how the MLE initiates the monitoring procedure in the MAC by sending TMC-MONITOR-LIST request along with a list of channel numbers which correspond to the frequencies of the adjacent cell carriers to be monitored.



**Figure 148: Monitoring scenario**

The result of the TMC-MONITOR-LIST request shall be contained in the TMC-MONITOR indication. The MAC shall make the measurements needed to calculate C2 for each adjacent cell channel and shall periodically pass the result for each one using TMC-MONITOR indication. The MS shall use the adjacent cell parameters broadcast on the serving cell for the C2 calculation. If the MS has not received these, the MS shall use the cell selection parameters of the serving cell to calculate C2 instead.

If the MS has already acquired synchronization on an adjacent cell and it has decoded the broadcast parameters needed to calculate C1, the MAC shall report the updated value of C1 for the adjacent cell using the TMC-SCAN-REPORT indication instead of reporting C2 for that cell.

A TMC-MONITOR-LIST request with an empty channel list shall inform the MAC to cease adjacent cell monitoring.

### 23.7.4.2 Monitoring measurements

The MAC shall measure the received RF signal strength or equivalent signal quality for all channels of the monitor list.

As far as possible the same number of measurement samples shall be taken for all channels and the measurement samples shall be uniformly distributed over the averaging period.

The MAC shall measure the received RF signal strength or make an equivalent signal quality measurement for all channels of the monitor list. For each channel, it shall calculate a running average of at least 5 measurement samples. These samples shall be taken during at least the last 5 s and at most the last 60 s. If less than 5 measurements were collected during this period, for example due to the constraints of an energy economy or dual watch mode, then the last 5 measurements may be used. The measurement sample duration shall be at least SD1 (refer to clause 10). Using the average of these measurements, the MAC shall calculate the parameter C2 at least every 5 s. The MAC may in addition calculate the parameter C1 for all channels of the monitoring list with which it has already synchronized and decoded the BNCH.

### 23.7.4.3 Signal strength measurement

The RSSI measurements or equivalent signal quality measurements shall be made during the non-assigned or non-used timeslots of the physical channel(s) to which the MS is attached.

**EXAMPLE** For example: for a receiving or idle MS, during the uplink slots of the physical channel; for a transmitting MS, during the downlink slots not already assigned to serving cell monitoring as defined by the monitoring pattern(s) allocated to the MS; for an MS in full duplex, during the unused uplink slot of the control frame.

The measurements shall be made whenever possible, taking into account the mode of operation and the frequency switching capability of the MS. However, the overall frequency of measurement, taking into account all channels, need not exceed the following rate:

- MS in half duplex RX or TX mode: 6 measurements per multiframe period;
- MS in idle mode: 1 measurement per 3 downlink slots of the MCCH or common SCCH.

If the channel does not operate in timesharing mode, the measurement sample duration shall be at least SD2 as defined in clause 10.

If the channel operates in timesharing mode and if the MS has knowledge of the timesharing synchronization, the MS shall perform the measurements only during the timeslots exclusively reserved to the monitored channel. If no active timeslots can be found that coincide with the monitoring periods, the measurement shall not be performed on this channel. If some can be found, the measurement sample duration shall be at least SD1.

If the channel operates in timesharing mode and if the MS does not have knowledge of the timesharing synchronization, the measurement sample duration shall be at least SD1 and several measurements are allowed on the same channel during one monitoring period. The MS shall calculate the average of the 5 samples showing the highest RF signal strength during the preceding 10 s, these samples being separated by at least 50 ms.

## 23.7.5 Scanning

Scanning is an MS function which measures the signal strength of the adjacent cells and calculates C1 using the adjacent cell parameters broadcast on the relevant adjacent cell. It is used when the MS is synchronized to the adjacent cell and is able to decode the adjacent cell BSCH and BNCH.

The following clause describes the scanning procedure. The MS MAC shall perform the measurements and fulfil the requirements of providing the C1 parameter to the MLE in a way which is equivalent to or better than the method described.

### 23.7.5.1 Scanning scenario

Figure 149 illustrates how the MLE initiates the scanning procedure in the MAC by sending TMC-SCAN request along with a channel number which corresponds to the frequency of the adjacent cell carrier to be scanned and a scanning measurement method to indicate whether foreground, background or interrupted scanning is to be used.

The MAC shall make the measurements needed to calculate C1 for the adjacent cell channel and shall pass the result using TMC-SCAN confirm. The MS shall use the cell selection parameters broadcast on the adjacent cell for the C1 calculation.

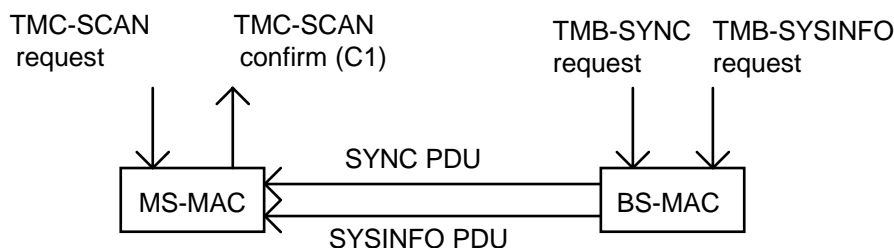


Figure 149: Scanning scenario

### 23.7.5.2 Scanning measurement

Scanning shall comprise of achieving synchronization with an adjacent cell, measuring the received signal strength or an equivalent signal quality and decoding the BSCH and BNCH broadcast on the adjacent cell. Scanning shall be performed on one channel at a time. Three different methods of scanning are defined:

- foreground, where scanning is the only activity;
- background, where communications with the current serving cell are maintained in parallel with the scanning, and the scanning causes no interruption to that service;
- interrupting, where communications with the current serving cell are maintained in parallel with the scanning, but the scanning causes limited interruptions to that service.

#### 23.7.5.2.1 Foreground scanning

Foreground scanning is used when the MS is in idle mode on the serving cell and wishes to scan an adjacent cell. The MS switches from the serving cell main carrier to the adjacent cell main carrier. The MS then acquires synchronization and makes the adjacent cell measurements before returning to the serving cell main carrier.

The MS MAC shall carry out the following in response to an MLE instruction to perform foreground scanning:

- change frequency to the channel to be scanned in the adjacent cell;
- attempt to acquire synchronization on the channel to be scanned and decode the cell selection parameters in BNCH. If the BNCH cannot be decoded within 5 s, the scanning shall be stopped;
- measure the received RF signal strength or equivalent received signal quality. These measurements shall be used for calculating C1. The averaging shall be calculated using at least 5 measurement samples, each sample having a duration of at least SD2 (as defined in clause 10). As far as possible, these samples should be evenly spread over at least 300 ms;
- calculate C1 for the scanned channel;
- return to the serving cell main carrier.

The MAC may decode the cell selection parameters at the same time as making the RSSI or equivalent measurements. Any measurements made within the 5 s before the start of scanning may also be used to calculate C1.

In the case where the BS is operating in timesharing mode, the measurements shall be made during the timeslots exclusively reserved to the scanned channel and the number of periods may be reduced to the number of active timeslots over a period of two multiframe.

#### 23.7.5.2.2 Background scanning

Background scanning is used when the MS wishes to scan an adjacent cell and maintain any current service on the serving cell, whether that is receiving the downlink control channel or transmitting or receiving as part of a call. The MS switches from the serving cell main carrier to the adjacent cell carrier in between any transmissions or receptions on the serving cell. The MS attempts to acquire synchronization on the adjacent cell during those times.

The signal strength measurements shall be identical to those performed during monitoring (see clause 23.7.4.3).

The MAC shall attempt to synchronize and read the BSCH and BNCH for the scanned channel. The MAC shall devote all its monitoring capability to these operations. The parameters decoded on the BNCH shall be used to calculate the path loss parameter C1.

The MAC shall keep the information concerning the time synchronization for the channels of the list. This information may be used to schedule the subsequent decoding of cell selection parameters and shall be used when accessing a re-selected cell.



When a new channel for which the MAC does not have synchronization has to be scanned, the MAC shall devote all its monitoring capability to synchronize on this channel and read the cell selection parameters contained in the BNCH, in priority over signal strength measurements on all other channels. If the cell selection parameters cannot be read within 15 s, a re-attempt shall not take place before  $\text{Attempt\_number} \times 15$  s after the end of the last attempt period,  $\text{Attempt\_number}$  being the number of attempts already performed.

The MAC shall attempt to read the cell selection parameters of each of the channels of the list at least every minute, to confirm that it is monitoring the same cell and update the value of these parameters. If a change of identity is detected then the channel shall be treated as a new channel in the list. If the BSCH cannot be decoded, a re-attempt shall be made at the next available opportunity.

For initial and subsequent cell selection parameters decoding, if the cell selection parameters cannot be decoded after 5 attempts, its channel shall be discarded from the list and any existing signal strength measurements shall be discarded.

The MAC shall re-calculate the parameter C1 at least every 10 s for the channels of the list based on the updated measurement done by monitoring (C2).

### 23.7.5.2.3 Interrupting scanning

Interrupting scanning is similar to foreground scanning except that the MS is participating in a call on the serving cell and temporarily suspends service in order to scan an adjacent cell.

The signal strength measurements shall be identical to those performed during monitoring (see clause 23.7.4.3).

The MAC shall attempt to synchronize, read the cell selection parameters and calculate the path loss parameter C1 for all channels as instructed by the MLE.

The MAC shall devote all its resources to these operations. If the cell selection parameters cannot be read within 5 s for a channel, all signal strength measurements on this channel shall be discarded.

The MAC shall keep the information concerning the time synchronization for the channels. This information may be used to schedule the subsequent decoding of cell selection parameters and when accessing a re-selected cell. Whenever the MAC re-calculates the parameter C2 for one of these channels, it shall re-calculate the parameter C1 for this channel. The MAC may periodically attempt to read the cell selection parameters for these channels, to confirm that it is monitoring the same cells and update the value of these parameters.

In the case where the radio link is relinquished before the link is declared relinquishable, the MAC shall first check all channels for which it has kept the time synchronization according to the indication given by the MLE. If none of the channels meets this criterion, the MAC shall perform the cell selection parameters measurement as for unprepared cell selection.

## 23.7.6 Selection of energy economy mode

An MS may enter energy economy mode by negotiating with the BS. This negotiation shall be performed by an MM message exchange (see clause 16.7.1). Once MM has negotiated a particular energy economy group, the MAC shall be informed using MLE-INFO request, TL-CONFIGURE request and TMC-CONFIGURE request primitives. These primitives shall include two parameters:

- "Energy economy group"; and
- "Energy economy start point".

"Energy economy group" shall specify how long the MS may sleep between receiving downlink slots on the control channel and shall have one of the values shown in table 349. "Energy economy start point" shall specify the frame and multiframe number at which energy economy operation shall begin.

**Table 349: Definition of the Economy Groups and duration**

Economy Group	Frames to sleep
EG1	1
EG2	2
EG3	5
EG4	8
EG5	17
EG6	71
EG7	359

An MS shall only request to enter energy economy mode while on the MCCH or a common SCCH. It shall receive and decode the relevant slot on the main carrier in all the frames up until and including the frame and multiframe given by the "Energy economy start point". The MS may then sleep for the number of frames indicated by the "Energy economy group". After this number of frames has elapsed, the MS shall then receive and decode the relevant downlink slot in the next frame. This operation (i.e. the regular cycle of sleeping for N frames and then receiving in one frame) shall continue while the MS remains in energy economy mode using this energy economy group.

An energy economy mode shall be valid in all cells within a Registered Area (RA). If an MS changes cell within the RA, it may maintain the same energy economy mode and follow the same energy economy pattern after acquiring slot and frame synchronization on the new cell (but using the frame and multiframe numbering of the new cell). All energy economy groups have a cyclic energy economy pattern within a hyperframe and so, given a start point and energy economy group, the MS may calculate the absolute frame and multiframe numbers it must monitor. Therefore, even although adjacent cells need not be synchronized, an MS may apply the same energy economy pattern on the new cell within the RA.

NOTE 1: At the time of the cell change, the MS may need to sleep for a shorter time if there is a different synchronization on the new cell. The MS then reverts to the negotiated cycle.

During energy economy mode, an MS shall temporarily suspend the sleeping cycle if:

- it obeys a channel allocation command allocating an assigned channel; or
- it becomes active in an advanced link; or
- it becomes active in a call (e.g. indicated by the MLE-ACTIVITY, TL-CONFIGURE and TMC-CONFIGURE request primitives from the higher layers); or
- it has signalling messages to send; or
- it receives a signalling message from the BS for any of its valid addresses or event labels, other than the predefined broadcast group address (all ones).

The MS shall return to the sleeping cycle when a time T.210 has elapsed since:

- it returned to the common control channel and the higher layers indicate no activity (e.g. using the MLE-ACTIVITY, TL-CONFIGURE and TMC-CONFIGURE request primitives); or
- it sent its last signalling message; or
- it last received a signalling message from the BS for one of its valid addresses or event labels, other than the predefined broadcast group address (all ones),

whichever is the most recent. During this time-out period, the MS shall continue to receive the downlink MCCH or common SCCH slot for any further signalling from the BS.

An MS shall end energy economy mode via an exchange of MM messages with the BS. MM instructs the MAC via the MLE-INFO, TL-CONFIGURE and TMC-CONFIGURE request primitives and the "Energy economy group" set to "Stay alive" to return to receiving the common control channel during all frames. The MAC shall begin this immediately and so the "Energy economy start point" parameter shall have no meaning in this case.

An MS in energy economy mode may request to change its energy economy group via an exchange of MM messages with the BS. From the perception of the MAC, this function is seen only as receiving an instruction from MM to end energy economy mode and then receiving another instruction to enter energy economy mode.

NOTE 2: Thus, as defined for ending energy economy mode, the MAC obeys the instruction to "Stay alive" immediately so the "Energy economy start point" parameter has no meaning in this case. On receiving the instruction to enter energy economy mode, the MS continues to receive the control channel in all frames up until and including the frame and multiframe given by the new "Energy economy start point". The MS may then sleep for the number of frames indicated by the new "Energy economy group". After this number of frames has elapsed, the MS then receives and decodes the relevant downlink slot in the next frame. Operation with the new sleeping cycle (i.e. the regular cycle of sleeping for N' frames and then receiving in one frame) continues while the MS remains in energy economy mode using this energy economy group.

If the MS is in energy economy mode and the MAC receives an instruction from MM to enter energy economy mode then it shall receive and decode the relevant slot on the main carrier in all frames up until and including the frame and multiframe given by the new "Energy economy start point". It shall then use the sleeping cycle defined by the new "Energy economy group".

NOTE 3: This case may occur if the BS changes the MS's energy economy parameters.

The MS shall end energy economy mode if it leaves the RA.

### 23.7.7 Selection of dual watch mode with energy economy group

An MS may enter dual watch mode by negotiating with the BS. This negotiation is performed by an MM message exchange (see clause 16.7.2). The procedures in this clause relate to dual watch mode when the MS is using an energy economy group.

NOTE 1: A full dual watch MS is capable of periodically receiving the V+D common control channel while it is in a Direct Mode call (when practicable). It is also capable of periodically receiving the Direct Mode RF carrier while it is in a V+D call and, when idle, it periodically receives both the Direct Mode RF carrier and the V+D common control channel. In order for the MS to periodically receive the V+D common control channel while in a Direct Mode call, the MS needs to request to use an appropriate energy economy group when it requests to perform the full dual watching procedure.

An MS may, alternatively, request to perform an idle dual watching procedure in which the MS may not be capable of receiving the V+D common control channel while it is in a Direct Mode call and may not be capable of receiving the Direct Mode RF carrier while it is in a V+D call. It is optional for the MS to request to use an energy economy group when it is performing the idle dual watching procedure.

The procedures defined in this clause relate to the full dual watching procedure. They apply also to the idle dual watching procedure in the case that the MS is using an energy economy group.

Once MM has negotiated dual watch mode with a particular energy economy group, the MAC shall be informed using MLE-INFO request, TL-CONFIGURE request and TMC-CONFIGURE request primitives. These primitives shall include two parameters:

- "Dual watch energy economy group"; and
- "Dual watch start point".

"Dual watch energy economy group" shall specify how long the MS may be unreachable (transmitting and/or receiving in Direct Mode, and/or sleeping) between receiving downlink slots on the V+D control channel and shall have one of the values shown in table 349. "Dual watch start point" shall specify the V+D frame and multiframe number at which dual watch mode using the agreed energy economy group shall begin.

An MS shall only request to enter dual watch mode while on the MCCH or a common SCCH. It shall receive and decode the relevant slot on the main carrier if practicable (i.e. unless Direct Mode requirements take precedence), in all the frames up until and including the frame and multiframe given by the "Dual watch start point". The MS may then be unreachable (transmitting and/or receiving in Direct Mode, and/or sleeping) for the number of frames indicated by the "Dual watch energy economy group". After this number of frames has elapsed, the MS shall then receive and decode the relevant downlink slot in the next V+D frame if practicable. This operation (i.e. the regular cycle of being unreachable for N frames and then receiving in one V+D frame when practicable) shall continue while the MS remains in dual watch mode using this energy economy group.

NOTE 2: The MS is required to receive and decode the V+D downlink slots defined in this clause only when practicable i.e. when Direct Mode requirements do not take precedence. When a full dual watching MS is a calling or called party in a Direct Mode call, Direct Mode requirements sometimes take precedence over V+D dual watch requirements (see ETS 300 396-3 [35], clause 8.4.7.10). When an idle dual watching MS is a calling or called party in a Direct Mode call, the MS may not be capable of receiving the V+D control channel for the duration of the Direct Mode call. Therefore the BS should be aware that a dual watching MS will not always be able to receive in the agreed slots. (This applies also in the case of an MS that is performing idle dual watch without an energy economy group.)

Also the BS should be aware that, even if the MS receives a V+D message, it may not always be able to send a response - even a layer 2 acknowledgement e.g. if the MS is currently in an emergency Direct Mode call or if the MS is in a non-emergency Direct Mode call and the BS does not grant a subslot or slot(s) on the current V+D channel. The BS should also be aware that, if it grants a subslot or slot(s) on the current V+D channel, the MS may sometimes need to use the first granted subslot for linearization (see clause 23.4.5). For a subslot or single-slot grant the MS should then send a response in the next granted subslot or slot (if this occurs within 4 multiframes). For a grant of more than one slot, the MS sends a response in the second granted slot.

Dual watch mode shall be valid in all cells within an RA. If an MS changes cell within the RA, it may maintain the same dual watch energy economy group and follow the same reception pattern after acquiring slot and frame synchronization on the new cell (but using the frame and multiframe numbering of the new cell). All energy economy groups have a cyclic reception pattern within a hyperframe and so, given a start point and energy economy group, the MS may calculate the absolute frame and multiframe numbers it must monitor when practicable. Therefore, even although adjacent cells need not be synchronized, an MS may apply the same reception pattern on the new cell within the RA.

NOTE 3: At the time of the cell change, the MS may need to be unreachable for a shorter time if there is a different synchronization on the new cell. The MS then reverts to the negotiated reception cycle.

A dual watching MS shall temporarily revert to receiving the V+D channel in all frames if:

- it obeys a channel allocation command allocating an assigned channel; or
- it becomes active in a V+D advanced link; or
- it becomes involved in a call (e.g. indicated by the MLE-ACTIVITY, TL-CONFIGURE and TMC-CONFIGURE request primitives from the higher layers).

NOTE 4: While on an assigned channel, or when active in a V+D advanced link or call, a full dual watching MS should still monitor the Direct Mode RF carrier if practicable, in order to look for calls addressed to itself. However, this may not always be practicable e.g. for a three-slot or four-slot V+D call or for the transmitting party in a circuit mode V+D call if the BS has assigned monitoring pattern 11<sub>2</sub> (i.e. three monitoring patterns).

While on an assigned channel, or when active in a V+D advanced link or call, an idle dual watching MS need not attempt to monitor the Direct Mode RF carrier.

If practicable (i.e. unless Direct Mode requirements take precedence), a dual watching MS shall temporarily revert to receiving the V+D channel in all frames if:

- it has V+D signalling messages to send; or
- it receives a signalling message from the BS for any of its valid addresses or event labels, other than the predefined broadcast group address (all ones).

NOTE 5: When the MS is in a Direct Mode call, it need not revert to receiving the V+D channel in all frames when it has V+D signalling messages to send or has received a signalling message from the BS (see ETS 300 396-3 [35], clause 8.4.7.10).

The MS shall return to the dual watch reception cycle when a time T.220 has elapsed since:

- it returned to the common control channel; or
- the higher layers indicated no V+D activity (e.g. using the MLE-ACTIVITY, TL-CONFIGURE and TMC-CONFIGURE request primitives); or
- it sent its last V+D signalling message; or
- it last received a signalling message from the BS for one of its valid addresses or event labels, other than the predefined broadcast group address (all ones),

whichever is the most recent. During this time-out period, the MS shall continue to receive the downlink MCCH or common SCCH slot in all frames if practicable (i.e. unless Direct Mode requirements take precedence), for any further signalling from the BS.

NOTE 6: The BS should be aware that it will not always be practicable for the MS to receive the V+D channel in all frames during the T.220 time-out period e.g. if the MS is currently in a Direct Mode call or if the MS user decides to initiate or receive a Direct Mode call.

An MS ends dual watch mode via an exchange of MM messages with the BS. MM instructs the MAC via the MLE-INFO, TL-CONFIGURE and TMC-CONFIGURE request primitives and the "Dual watch energy economy group" set to "Stay alive" to return to receiving the common control channel during all frames. The MAC shall begin this immediately and so the "Dual watch start point" parameter shall have no meaning in this case.

An MS in dual watch mode may request to change its energy economy group via an exchange of MM messages with the BS. From the perception of the MAC, this function is seen only as receiving an instruction from MM to "Stay alive" and then receiving another instruction to enter dual watch mode with the specified energy economy group.

If the MS is in dual watch mode and the MAC receives an instruction from MM to enter dual watch mode with a specified energy economy group then it shall receive and decode the relevant slot on the main carrier if practicable (i.e. unless Direct Mode requirements take precedence), in all frames up until and including the frame and multiframe given by the new "Dual watch start point". It shall then use the reception cycle defined by the new "Dual watch energy economy group".

NOTE 7: This case may occur if the BS changes the MS's dual watch energy economy group.

The MS cannot operate in both normal energy economy mode and dual watch mode at one time. An MS in energy economy mode may request to change to dual watch mode via an exchange of MM messages with the BS. Conversely, an MS in dual watch mode may request to change to energy economy mode via an exchange of MM messages with the BS. From the perception of the MAC, this function is seen only as receiving an instruction from MM to "Stay alive" and then receiving another instruction to enter the other mode with the specified energy economy group.

The MS shall end dual watch mode if it leaves the RA.

## 23.8 PDU transfer for traffic (TMD-SAP)

### 23.8.1 Introduction

For a message trunked system, a complete circuit mode call generally takes place on one assigned channel. Before any traffic transmission, the BS allocates a traffic usage marker for the call.

For a transmission trunked system, each traffic transmission (i.e. "overs") takes place on an assigned channel. Between "overs", the MS is directed to a common control channel or to an assigned SCCH. Before each traffic transmission, the BS allocates a traffic usage marker for use on the assigned channel.

For a quasi-transmission trunked system, each traffic transmission takes place on an assigned channel. At the end of an "overs", the MS(s) remain on the assigned channel for a short period (i.e. the channel hang-time). If another traffic transmission for the call is requested within the hang-time then the same channel is used for that traffic transmission. Otherwise, after the hang-time, the BS directs the MS(s) to a common control channel, or to an assigned SCCH, until the next traffic transmission is requested; the BS then assigns a channel for that traffic transmission (either the previous assigned channel or a different channel). Before any traffic transmission on an assigned channel, the BS allocates a traffic usage marker for use on that channel.

The choice between these modes is made by the BS. The MS procedures operate independently of this BS choice.

During a call, ACCH is always available in frame 18. When frames 1 to 17 are not being used for traffic, the fast ACCH is available in frames 1 - 18 (see clause 23.3.1.3). In the case of independent allocation of uplink and downlink, or for an inter-site call, the availability of FACCH at any time may be independent on uplink and downlink.

The usage of both uplink and downlink is indicated, independently, in the AACH. A traffic usage marker is used when the corresponding direction is in use for traffic (i.e. TCH or STCH). During FACCH, the uplink is controlled by the access field, and the downlink is marked with the assigned control or common control pre-set usage marker as appropriate.

In traffic mode, on frames 1 to 17, capacity may be stolen from the circuit for signalling purposes, without changing the current mode of operation. Use of normal training sequence 2 (i.e. SF= 1 ) indicates when stealing has occurred and the MAC header in the first half slot indicates whether the second half slot is also stolen. This mechanism applies to both uplink and downlink.

See clause 19 for the configuration of the lower MAC in signalling and traffic mode. The default mode is signalling mode.

**NOTE:** The STCH mechanism applies only when the channel is in traffic mode, allowing signalling messages to be sent within an "overs", and without waiting for frame 18. For example: U-plane signalling (i.e. user-to-user signalling and/or encryption synchronization) is sent on STCH; CC PDU U-TX-CEASED should normally be sent on STCH; and D-TX-CEASED may be sent on STCH. C-plane signalling messages unrelated to the call may also be sent on STCH.

Between "overs" on a message trunked (or quasi-transmission) trunked system, the assigned channel will normally return to signalling mode (FACCH). The SCH procedures then apply.

## 23.8.2 Criteria for transmission and reception of traffic

During a circuit mode call:

- a sending MS needs to be instructed when to start sending traffic (and when to stop);
- a receiving MS needs to know when to process any received TCH (and when to stop).

This process shall be performed by CC messages sent by the BS to the appropriate MS(s). The CMCE in the MS shall then instruct the MS-MAC using the TMC-CONFIGURE request primitive. There are also some back-up mechanisms using the AACH.

### 23.8.2.1 Use of TMC-CONFIGURE primitive

For the purposes of the protocol description, it is assumed that the instruction from the CMCE for changing the operating mode in the MS-MAC comprises the following sub-parameters:

- switch U-plane on/off;
- Tx-grant flag;
- simplex/duplex flag;
- type of circuit (i.e. TCH/S, TCH/2,4, TCH/4,8, TCH/7,2);
- interleaving depth N;
- end-to-end encryption flag;
- user device;
- endpoint identifier.

The possible combinations of the first three sub-parameters may be:

- a) Switch U-plane on, Tx-grant, Simplex: MS is authorized to transmit TCH;
- b) Switch U-plane on, Not Tx-grant, Simplex: MS is authorized to receive TCH;
- c) Switch U-plane on, Tx-grant, Duplex: MS is authorized to transmit and receive TCH;
- d) Switch U-plane off: Withdraws previous authorization to transmit and/or receive TCH.

The upper MAC shall inform the lower MAC of the appropriate type of TCH logical channel for transmission and/or reception, since this affects the coding/decoding method.

For the purposes of the protocol description, it is assumed that the process of the MAC issuing a TMA-UNITDATA indication primitive containing a CC message and then receiving the corresponding TMC-CONFIGURE request primitive is effectively instantaneous except in the case when the MS decides to obey a group addressed channel allocation after a delay.

If the MS decides to obey a group addressed channel allocation after a delay then the CMCE may indicate TCH receive authorization when it accepts the channel allocation. However, the MS-MAC shall not use this authorization if the decision to move to the allocated channel has been delayed by more than a time T.215 (see clause 23.8.2.2). If the decision has been delayed by more than a time T.215 then, after moving to the allocated channel, the MS shall not process received TCH until the "N.213 permission method" criterion applies (see clause 23.8.2.3.2) or until authorization by another CC message.

NOTE 1: In case a) above, the MS continues to receive the downlink in the normal manner (subject to the defined monitoring pattern(s)) and using the procedures in clause 23.5.6.3 for interpretation of the downlink. The downlink may be either in signalling or traffic mode.

NOTE 2: If the MS has independent circuit mode calls in progress on the uplink and downlink of the channel, it should use appropriate means to distinguish between the operating mode instructions from the CMCE.

NOTE 3: The MAC may receive changes to the operating mode for the same call, with consecutive changes both containing the instruction to "Switch U-plane on". For example, this may occur if the next traffic transmission has already been requested so that there is no need to return to signalling mode. The most recent instruction for the call over-writes previous instructions, e.g. case b) after case a) withdraws the TCH transmit authorization and gives TCH receive authorization; case a) after case b) withdraws the TCH receive authorization and gives TCH transmit authorization.

### 23.8.2.2 Timing of change of mode

For a switch to U-plane transmission, the MS shall use the following timings:

- If the downlink slot containing the transmit permission (or the final fragment) contained no channel change and no slot grant, then:
  - if in frames 1 to 17, the MS shall start sending traffic in the corresponding uplink slot in that TDMA frame;
  - if in frame 18, the MS shall start sending traffic in frame 1.

NOTE 1: If the MS with transmit permission has received previous slot grants on the assigned channel then that MS should assume that any granted slots in frames 1 to 17 are withdrawn whereas any granted slots in frame 18 are still valid.

- If the downlink slot containing the transmit permission (or the final fragment) contained a slot grant, either with no channel change or with a grant on the allocated channel, then the MS shall start sending traffic in the next full uplink slot on the assigned channel in frames 1 to 17, following the end of the grant. This rule applies even if the grant exceeds the MS's requirement to send signalling messages. When the MS starts sending traffic, see note 1 applies to any previous slot grants on the assigned channel.

- If the downlink slot containing the transmit permission (or the final fragment) contained a channel change and no slot grant on the allocated channel, then:
  - if CLCH permission is given then the MS shall start sending traffic in the next uplink slot on the assigned channel in frames 1 to 17; this is the next valid full uplink traffic slot following the slot containing the potential CLCH subslot, even if the MS does not need to use CLCH;
  - if CLCH permission is not given, e.g. no change of RF carrier, then the MS shall start sending traffic in the first uplink slot on the allocated channel (as defined in clause 23.5.4.3.1) if that slot is in frames 1 to 17, or else in frame 1.

In the first traffic slot, and if the DATA-IN-BUFFER signal from the LLC indicates that there is a message in the buffer for this channel with the stealing permission parameter set to "steal within time T.214" or "steal immediately", then the MS-MAC shall issue a MAC-READY signal to the LLC offering stolen capacity, e.g. for a layer 2 acknowledgement to the layer 3 transmit permission message.

NOTE 2: For the purposes of the above procedures for timing a switch to U-plane transmission, a "slot grant" refers to a grant with "granting delay"  $\neq 1111_2$ . So the MS should regard a "slot granting" element with "granting delay" =  $1111_2$  as not being a slot grant.

For a switch to U-plane reception, with no channel change:

- for a single-slot channel, or for a multi-slot channel in which the next downlink slot is not part of that channel, the MS shall switch to U-plane reception at the end of the downlink slot containing the receive permission;
- for a multi-slot channel, and if the next downlink slot is part of that channel, the MS shall delay the switch to U-plane reception by one timeslot duration.

EXAMPLE: For example: for a multi-slot channel comprising timeslots 2, 3 and 4, with a switch instruction in downlink slot 2, the MS assumes SCH for downlink slot 3 and then switches to U-plane reception for downlink slot 4. Whereas, if the switch instruction is in downlink slot 4 then the MS switches to U-plane reception for downlink slot 2 in the next frame.

For a switch to U-plane reception, with a channel change, the MS shall switch to U-plane mode when it moves to the allocated channel, for reception of the first downlink slot on the allocated channel (as defined in clause 23.5.4.3.1). The MS shall use this procedure for an individually addressed channel allocation or if the MS makes an immediate decision to obey a group addressed channel allocation. Also, the MS may use this procedure when it decides to obey a group addressed channel allocation after a delay, provided that the MS-MAC receives the TMC-CONFIGURE request primitive accepting the channel allocation within a time T.215 after receipt of the channel allocation.

In the case of a group addressed channel allocation, if the MS-MAC receives the TMC-CONFIGURE request primitive accepting the channel allocation more than a time T.215 after receipt of the channel allocation then, after moving to the allocated channel, the MS shall not process received traffic until the "N.213 permission method" criterion applies (see clause 23.8.2.3.2) or until authorization by another CC message.

For a switch out of U-plane transmission:

- for a single-slot channel, or for a multi-slot channel in which the next uplink slot is not part of that channel, the MS shall switch mode immediately, i.e. as soon as the downlink message has been processed;
- for a multi-slot channel, and if the next uplink slot is part of that channel, the MS shall delay the switch by one timeslot duration.

EXAMPLE: For example: for a multi-slot channel comprising timeslots 2, 3 and 4, with a switch instruction in downlink slot 3, e.g. in frame 10, the MS continues to transmit TCH or STCH in uplink slot 2 before switching. Whereas, if the switch instruction is in downlink slot 2 then the MS stops U-plane transmission at the end of the coinciding uplink slot 4.

For a switch out of U-plane reception:

- for a single-slot channel, or for a multi-slot channel in which the next downlink slot is not part of that channel, the MS shall switch mode at the end of the downlink slot containing the switch instruction;
- for a multi-slot channel, and if the next downlink slot is part of that channel, the MS shall delay the switch by one timeslot duration.



**EXAMPLE:** For example: for a multi-slot channel comprising timeslots 2, 3 and 4, with a switch instruction in downlink slot 2, the MS assumes TCH or STCH for downlink slot 3 and SCH for downlink slot 4.

**NOTE 3:** If the BS does not receive an expected layer 2 acknowledgement to a downlink message giving or withdrawing authorization to receive traffic on the downlink, it cannot know whether the MS actually received the message; therefore, it cannot know whether the MS is in signalling or traffic mode for reception. In either case, if the BS wishes to send a re-transmission, it is necessary that the MS is able to interpret the downlink channel correctly. At this time, it is recommended that the BS uses only normal training sequence 2, sending either STCH + STCH or SCH/HD + SCH/HD. Interpretation of these forms by MSs is very similar, provided that the BS uses only "length indication"  $111110_2$  or  $111111_2$  in the last PDU in a first half slot, even if that half slot actually contains SCH/HD.

**NOTE 4:** After being authorized to receive traffic, the MS may switch to traffic mode almost immediately. If TCH from the source is not ready at this time, the BS should send C-plane STCH + STCH on the downlink, e.g. containing Null PDUs.

**NOTE 5:** As specified above, the switch out of U-plane mode is almost immediate after the CMCE has received the command from the BS. Therefore, for a circuit mode data call with an interleaving depth of  $N = 4$  or  $8$ , the CMCE in the transmitting MS should ensure that the MS has been able to issue  $N - 1$  slots containing tail bits (zeros) to the lower MAC at the end of the required data transmission (on each allocated slot in the case of a multi-slot channel) before sending the U-TX-CEASED PDU to the BS. These tail bits are needed to complete the interleaving of the circuit mode data.

### 23.8.2.3 AACH mechanisms

The following procedures specify criteria for stopping transmitting or receiving traffic. There are also criteria for leaving an assigned traffic channel, based on received AACH. (See clause 23.5.6 for maintenance of an assigned channel.)

#### 23.8.2.3.1 MS transmitting traffic

The MS shall not transmit traffic unless it has been authorized by a CC message and has a traffic usage marker applicable to the uplink channel (i.e. assigned with element "Up/downlink Assigned" =  $10_2$  or  $11_2$ ).

During traffic transmission, the MS shall receive and attempt to decode the downlink assigned channel for at least those frames defined by the monitoring pattern information, within the capabilities of that MS.

After starting to transmit traffic, and if the BS does not allow U-plane DTX (i.e. discontinuous traffic transmission by the MS), then the MS shall transmit traffic (TCH and/or STCH) in frames 1 to 17, in successive slots on the uplink assigned channel, as defined by element "Timeslot Assigned", until any one of the following criteria a), b), c) or d) occurs.

**NOTE 1:** The "U-plane DTX" element in the SYNC PDU indicates whether or not the BS supports discontinuous traffic transmission by the MS.

After starting to transmit traffic, and if the BS allows U-plane DTX, then the MS may transmit traffic (TCH and/or STCH) in frames 1 to 17 on the uplink assigned channel, and shall transmit in at least one traffic slot every T.213 TDMA frames, until any one of the following criteria a), b), c) or d) occurs.

- a) Authorization to transmit traffic is withdrawn (either by an instruction to switch the U-plane off or by a switch from transmit to receive for this call).
- b) If one or more monitoring patterns were assigned, i.e. element "Monitoring Pattern"  $\neq 00_2$ :
  - N.211 successive ACCESS-ASSIGN PDUs received in frames 1 to 17 on the downlink assigned channel contain "Header"  $\neq 11_2$  or do not contain the correct uplink traffic usage marker.

If no monitoring pattern was assigned, i.e. element "Monitoring Pattern" =  $00_2$ :

- N.211 successive ACCESS-ASSIGN PDUs received in any frame on the downlink assigned channel contain "Header"  $\neq 11_2$  or do not contain the correct uplink traffic usage marker.

- c) If one or more monitoring patterns were assigned, i.e. element "Monitoring Pattern"  $\neq$  00<sub>2</sub>:
- a time T.211 elapses without receipt of an ACCESS-ASSIGN PDU in frames 1 to 17 on the downlink assigned channel, containing "Header" = 11<sub>2</sub> and containing the correct uplink traffic usage marker.

If no monitoring pattern was assigned, i.e. element "Monitoring Pattern" = 00<sub>2</sub>:

- a time 18 \* T.211 elapses without receipt of an ACCESS-ASSIGN PDU in any frame on the downlink assigned channel, containing "Header" = 11<sub>2</sub> and containing the correct uplink traffic usage marker (as "Field 2" in frames 1 to 17 or "Field 1" in frame 18).

- d) The MS leaves the assigned channel (see clause 23.5.6.1).

NOTE 2: For a multi-slot channel, if the MS is not frequency full duplex, and if the BS assigns monitoring pattern(s) that the MS is not capable of following in any slots in frames 2 - 17, then, in criteria b) and c), the MS should use the method specified for element "Monitoring Pattern" = 00<sub>2</sub>.

In all cases a), b), c) and d), the MS shall stop transmitting traffic (TCH and STCH) and shall revert to the normal C-plane methods of random access and reserved access in all frames 1 - 18.

In cases b) or c), the MS-MAC shall report the change of mode to the higher layers using the TMC-REPORT indication primitive.

In case d), the interruption may be only temporary. If the MS is changing channel on instruction from the BS and if:

- the "Allocation Type" = 00<sub>2</sub> or 11<sub>2</sub> ("Replace" or "Replace + CSS channel"); and
- the MS is being directed to an assigned channel (i.e. element "Timeslot Assigned"  $\neq$  0000<sub>2</sub>); and
- the uplink is assigned (i.e. element "Up/downlink Assigned" = 10<sub>2</sub> or 11<sub>2</sub>); and
- the MS receives a traffic usage marker assignment with the channel allocation; and
- the MS does not receive a CC message withdrawing authorization to transmit traffic; and
- this is an individually addressed channel allocation or, for a group addressed channel allocation, the MS decides within a time T.216 to obey the channel allocation,

then, on receipt of the channel allocation, the MS-MAC shall stop transmitting traffic on the current channel. For a single-slot channel, or for a multi-slot channel in which the next uplink slot is not part of that channel, the MS shall stop transmitting traffic immediately. For a multi-slot channel, and if the next uplink slot is part of that channel, the MS shall delay the switch by one timeslot duration. After changing channel, the MS shall continue traffic transmission as follows:

```

if the MS has a slot grant on the assigned channel
then the MS shall continue traffic transmission in the next uplink slot on the assigned
    channel (in frames 1 to 17), following the end of the slot grant
else
if "Immediate CLCH permission" is given
then the MS shall continue traffic transmission in the next full uplink slot on the
    assigned channel (in frames 1 to 17), following the slot containing the potential CLCH
    subslot
else the MS shall continue traffic transmission in the first uplink slot on the allocated
    channel (as defined in clause 23.5.4.3.1) if that slot is in frames 1 to 17 or
    otherwise in frame 1.

```

This rule shall apply both for allocation within the same cell and for a different cell (seamless handover).

For a channel change that does not conform to the above, or if the MS decides not to move to the allocated channel, the MS-MAC shall stop transmitting traffic and shall report the change of mode to the higher layers.

If, after starting to transmit traffic and at any time other than during a temporary interruption for channel change, the MS receives a slot grant addressed to itself, and granting a reserved uplink subslot or slot(s) in frames 1 to 17 (i.e. where it expected to transmit traffic), then the MS-MAC shall stop transmitting traffic, reporting the change of mode to the higher layers.

NOTE 3: The scenario above should not occur except in case of transmission errors. It is not intended for use by the BS as a normal method for ending U-plane transmission.

NOTE 4: Criterion b) refers to a check on those ACCESS-ASSIGN PDUs that are successfully decoded by the MS, irrespective of whether or not these are in successive slots on the assigned channel. Then criterion c) covers the case when the AACH is not successfully decoded during the specified time.

If no monitoring pattern is assigned, the BS should use "Header"  $11_2$  in ACCESS-ASSIGN PDUs in frame 18 on the downlink assigned channel, including the traffic usage marker of the transmitting MS. This applies also for a multi-slot channel if the BS assigns monitoring pattern(s) that the MS may not be capable of following in any slots in frames 2 to 17.

NOTE 5: The "channel replace" mechanism without withdrawal of transmit authorization may be used within the cell, for convenience of BS resource allocation, or between cells e.g. for seamless handover. Before continuing U-plane transmission, the MS may be required to transmit a C-plane reply, in a reserved slot on either the current or allocated channel, or by stealing.

Alternatively, the BS may prefer to interrupt the traffic transmission by sending the CC PDU D-TX-WAIT (temporarily withdrawing transmit permission).

### 23.8.2.3.2 MS receiving traffic

The MS should process received traffic after authorization by a CC message, except that it shall not process received TCH if it does not have a traffic usage marker applicable to the downlink channel (i.e. assigned with element "Up/downlink Assigned" =  $01_2$  or  $11_2$ ). Also, if a group addressed channel allocation was sent with the CC message and the decision to accept the channel allocation was delayed by more than time T.215 then the MS shall not process received TCH on the allocated channel until the "N.213 permission method" criterion applies or until authorization by another CC message.

The MS may process received traffic, without specific authorization, if N.213 ACCESS-ASSIGN PDUs received in frames 1 to 17 in successive slots appropriate to the downlink assigned channel contain Header  $\neq 00_2$  and contain the correct downlink traffic usage marker for this MS. The MS-MAC should report the change of mode to the higher layers using the TMC-REPORT indication primitive.

NOTE 1: If the CMCE indicates traffic receive permission when it accepts a group addressed channel allocation after a delay of more than time T.215 then the MS-MAC is not precluded from reducing its value of N.213 provided that the reduced value of N.213  $\geq 2$ . This applies also for a channel replacement without withdrawal of receive authorization if the MS accepts a group addressed channel allocation after a delay of more than time T.215 (see below). The reduced value of N.213 may apply until the MS next receives a CC message indicating authorization or withdrawal of authorization to transmit or receive traffic on the allocated channel.

The MS shall process any received traffic (TCH and STCH) in frames 1 to 17 in slots on the downlink assigned channel until any one of the following occurs:

- a) authorization to receive traffic is withdrawn (either by an instruction to switch the U-plane off or by a switch from receive to transmit for this call);
- b) N.212 successive ACCESS-ASSIGN PDUs received in frames 1 to 17 on the downlink assigned channel contain "Header" =  $00_2$  or do not contain the correct downlink traffic usage marker;
- c) a time T.212 elapses without receipt of an ACCESS-ASSIGN PDU in frames 1 to 17 on the downlink assigned channel, containing "Header"  $\neq 00_2$  and containing the correct downlink traffic usage marker;
- d) the MS leaves the assigned channel (see clause 23.5.6.1), unless the criteria described below are satisfied.

In all cases, the MS shall stop processing received traffic.

In cases b), c) or d), the MS-MAC shall report the change of mode to the higher layers using the TMC-REPORT indication primitive.

In all cases, the MS may again process received traffic either after authorization by a CC message or by using the "N.213 permission method" described above.

The exception to case d) is that, if the MS changes channel on instruction from the BS and if:

- the "Allocation Type" = 00<sub>2</sub> or 11<sub>2</sub> ("Replace" or "Replace + CSS channel"); and
- the MS is being directed to an assigned channel (i.e. element "Timeslot Assigned" ≠ 0000<sub>2</sub>); and
- the downlink is assigned (i.e. element "Up/downlink Assigned" = 01<sub>2</sub> or 11<sub>2</sub>); and
- the MS receives a traffic usage marker assignment with the channel allocation; and
- the MS does not receive a CC message withdrawing authorization to receive traffic; and
- this is an individually addressed channel allocation or, for a group addressed channel allocation, the MS decides within a time T.215 to obey the channel allocation,

then the MS-MAC shall switch out of U-plane reception at the end of the downlink slot containing the channel allocation; or, for a multi-slot channel, and if the next downlink slot is part of that channel and the MS is still on the current channel to receive that slot (see note 2), the MS shall delay the switch by one timeslot duration. The MS shall switch back to U-plane reception when it moves to the allocated channel, using the newly assigned usage marker, for reception of the first downlink slot on the allocated channel (as defined in clause 23.5.4.3.1).

This rule shall apply both for allocation within the same cell and for a different cell.

NOTE 2: For the purposes of this procedure it is assumed that, for a multi-slot channel, and if the next downlink slot is part of that channel, then the MS is "still on the current channel to receive that slot" only in the cases defined in condition b) of procedure 1) in clause 23.5.4.3.1 and, for a frequency full duplex MS, condition c) of procedure 1) in clause 23.5.4.3.1 i.e. in the cases of a channel allocation with a slot grant on the current channel and, for a frequency full duplex MS, if the next immediate uplink slot following the channel allocation is part of the current channel and the MS is transmitting traffic in that slot or was previously granted that slot (or a subslot in that slot) for reserved access. So, for the purposes of this procedure, it is assumed that the MS is not "still on the current channel to receive that slot" if the timing of the channel change is based on condition a) of procedure 1) in clause 23.5.4.3.1.

NOTE 3: Criterion b) refers to a check on those ACCESS-ASSIGN PDUs that are successfully decoded by the MS, irrespective of whether these are in successive slots on the assigned channel. Whereas the "N.213 permission method" applies only if ACCESS-ASSIGN PDUs are successfully decoded in successive traffic slots on the assigned channel.

NOTE 4: The permission method based on parameter N.213 should not be used by an MS that is transmitting in simplex mode and that has only one circuit mode call on this channel i.e. the MS should not attempt to transmit and receive simultaneously in a simplex call.

NOTE 5: The "channel replace" mechanism without withdrawal of receive authorization may be used within the cell, for convenience of BS resource allocation, or between cells e.g. for seamless handover.

If an MS that is receiving traffic is sent to a different timeslot during an end-to-end encrypted call, the BS may choose to interrupt the transmitting station with the D-TX-WAIT PDU, thereby causing the transmitting station to re-send encryption synchronization when the transmission starts again.

NOTE 6: In the case of circuit mode data, in order to avoid corrupting downlink data transmission, the BS designer may prefer (when possible) to send any channel allocation commands or D-TX-WAIT PDUs in frame 18.

NOTE 7: The MS is not permitted to maintain traffic receive authorization if it accepts a group addressed channel allocation after a delay of more than time T.215; after moving to the new channel, it cannot process received TCH until the "N.213 permission method" criterion applies (using the traffic usage marker for the new channel) or until authorization by a CC message.

### 23.8.2.3.3 Multi-slot interleaving with interruption

If a circuit mode data transmission is interrupted, either by use of the CMCE's D-TX-WAIT mechanism or by a "channel replace", as defined in the above two clauses, then the MS shall continue with the transmission or reception of the data as if the intervening time out of U-plane mode had not been present. This rule includes the interleaving/de-interleaving of the data for interleaving depth  $N = 4$  or  $8$ .

For a single-slot channel with  $N = 4$  or  $8$ , the MS shall continue to process the U-plane data after the interruption, performing interleaving/de-interleaving of the old data with the new data as traffic blocks are transmitted/received.

For a multi-slot channel with  $N = 4$  or  $8$ , multiple single-slot data TCHs are operated in parallel in order to obtain the multi-slot TCH transmission, as defined in clause 23.3.5. After an interruption, the order of presentation of the data at the receiving side shall be maintained. Therefore, across the interruption, the single-slot TCHs may be linked between different timeslot numbers according to the next occurring traffic slot.

**EXAMPLE:** For example, for a multi-slot channel comprising timeslots 1, 2 and 3, where a slot 1 is the last traffic slot before interruption and a slot 3 is the next traffic slot:

- the old interleaving process corresponding to slot 2 continues in slot 3;
- the old interleaving process corresponding to slot 3 continues in slot 1;
- the old interleaving process corresponding to slot 1 continues in slot 2.

Similarly, for a multi-slot channel comprising timeslots 1, 2 and 3, with a new channel allocation comprising timeslots 1, 3 and 4, where a slot 2 contained the last traffic on the old channel and a slot 3 contains the first traffic on the new channel:

- the old interleaving process corresponding to slot 3 continues in slot 3;
- the old interleaving process corresponding to slot 1 continues in slot 4;
- the old interleaving process corresponding to slot 2 continues in slot 1.

This second example could be caused either by use of the channel replace without withdrawal of U-plane authorization, or by use of the D-TX-WAIT mechanism with a channel replacement during the pause.

**NOTE:** The procedures defined in this clause do not apply for a group addressed channel replacement if the MS decides to obey the channel allocation after a delay.

## 23.8.3 Exchange of information at the TMD-SAP

In the protocol model, the actual user traffic is transferred between the U-plane application (e.g. the speech CODEC) and the MS-MAC via the TMD-SAP. The TMD-SAP is used for the transfer of speech frames or circuit mode data. It is also used if the U-plane application steals from the traffic capacity to send U-plane signalling.

For the purposes of the protocol description, the following services primitives are used. However, this does not imply any specific implementation. The word "shall" is used with the primitives and their parameters for traceability reasons in the protocol model, but the primitives are not testable.

- The TMD-UNITDATA request primitive shall be used when the U-plane application wishes to send information to the peer entity.
- The TMD-UNITDATA indication primitive shall be used for the MS-MAC to deliver information from the peer entity.
- The TMD-REPORT indication shall be used by the sending MAC to issue reports to the U-plane application e.g. at the start and stop of traffic transmission, and when the MS changes channel within an "over", and when the MAC has stolen from the traffic capacity. It shall also be used by the receiving MAC at the start of a call.

The parameters specific to the TMD-UNITDATA primitive are as follows (see clause 20):

a) Half slot content:

The unit of information in the TMD-UNITDATA primitive is one half slot. The U-plane application shall provide a TM-SDU of the correct size for the appropriate logical channel, so that the MS-MAC does not have to insert filler bits to complete the MAC block nor have to remove filler bits on reception.

In particular, when the U-plane application steals from the traffic capacity for U-plane signalling, the TM-SDU shall always be 121 bits. The upper MAC shall then add a 3-bit MAC header, making the MAC block up to the 124 bits required for STCH. The U-plane signalling may be for user-to-user signalling or for encryption synchronization. However, the MAC is not aware of the intended purpose of the U-plane signalling. (Any necessary discrimination shall be included within the TM-SDU.)

User traffic TCH does not have a MAC header.

b) Half slot position:

Each transferred half slot (in either direction) should be accompanied by a marker identifying it as the first or second half slot of a timeslot.

At all points in the system, half slots should be grouped in pairs, equivalent to the data transmitted over the air interface in one slot. The binding between these pairs shall remain intact and the correct timing/ordering relationships with adjacent half slots preserved, even when a half slot is stolen and the half slots are processed separately by the MAC.

c) Stolen indication:

At the transmitting side, this parameter shall indicate whether the half slot is stolen for U-plane signalling or not stolen.

At the receiving side, this parameter shall indicate whether the half slot was stolen for C-plane signalling, stolen for U-plane signalling or not stolen.

d) Half slot importance:

This parameter may be used only in the TMD-UNITDATA request primitive. It indicates the importance of the U-plane information, enabling the sending MS-MAC to decide when and whether to steal from the traffic capacity and to decide whether to use U-plane DTX (discontinuous traffic transmission). Four levels of importance may be used: no importance, and low, medium and high importance.

e) Half slot condition:

This parameter may be used only in the TMD-UNITDATA indication primitive. It indicates to the receiving U-plane application whether a half traffic slot was received successfully. It may take the following values:

- "Good" if the half slot was decodeable;
- "Bad" if a valid training sequence was detected but the CRC check failed;
- "Null" if no valid training sequence was detected.

The distinction between "Good" and "Bad" is not appropriate for TCH/7,2.

f) User device:

The user device parameter shall identify the appropriate circuit.

NOTE 1: For the purposes of the protocol description, channel encoding and decoding are performed in the lower MAC. However, this does not imply any particular implementation. If, for example, the implementers were to choose to perform the channel coding of TCH directly in the CODEC, then the descriptions of half slot transfer generally still apply (though the distinction between "Good" and "Bad" in the "half slot condition" parameter is no longer relevant).

NOTE 2: For the purposes of the protocol description, the unit of exchange at the TMD-SAP is always a half slot (corresponding to one speech frame). However, this does not imply any particular implementation. For example, implementers may prefer to use a full slot of data as the unit of exchange for circuit mode data TCH.

NOTE 3: It is assumed that the U-plane application provides valid data in the "half slot content" parameter even if the "half slot importance" is set to "no importance".

### 23.8.3.1 Interface at transmitting MS

At the start of a call (or before each "over"), or if the basic service information changes, the MS-MAC shall issue a report to the U-plane application to supply the traffic type, the interleaving depth, the number of slots per frame, a flag indicating whether end-to-end encryption applies and the user device parameter.

When the MS has been authorized to transmit TCH, and has established whether it will steal the first half slot for C-plane signalling (e.g. a layer 2 acknowledgement), the MS-MAC shall issue a report to the U-plane application. This report shall indicate the initial half slot synchronization i.e. whether the first valid U-plane half slot is a first or second half slot; that half slot may then be used either for TCH or for U-plane signalling.

A report should be issued to the U-plane application if there is any interruption (e.g. a channel change) so that, for an end-to-end encrypted call, the U-plane application can send encryption synchronization again.

A report should also be issued to the U-plane application when traffic transmission is no longer permitted.

When transmitting a slot in traffic mode, the sending MS-MAC is generally given the first half slot by the U-plane application, in a TMD-UNITDATA request primitive. That half slot may be either TCH, or U-plane signalling in the case of stealing by the U-plane application.

If the MS-MAC decides to steal the first half slot for C-plane signalling then the MAC should issue a TMD-REPORT indication, enabling the U-plane application to revise the intended use of the second half slot.

The MS-MAC is then given the second half slot in another TMD-UNITDATA request primitive. Again, if the MS-MAC decides to steal the half slot for C-plane signalling then the MAC should issue a TMD-REPORT indication.

In the case of circuit mode data with low or high protection: if the U-plane application steals the first half slot but not the second half slot then it should issue two TMD-UNITDATA request primitives for the first half slot (one containing the U-plane signalling data and the other containing TCH) and one TMD-UNITDATA request primitive for the second half slot (containing TCH). In the case of circuit mode data with interleaving depth  $N = 4$  or  $8$ : if the U-plane application steals both half slots then it should issue two TMD-UNITDATA request primitives for each half slot (one containing the U-plane signalling data and the other containing TCH).

At this time, the MS-MAC has the contents of one slot. Permitted combinations for the two half slots are as follows:

- a) Not stolen i.e. TCH / Not stolen i.e. TCH;
- b) Stolen for C-plane / Not stolen i.e. TCH;
- c) Stolen for U-plane / Not stolen i.e. TCH;
- d) Stolen for C-plane / Stolen for C-plane;
- e) Stolen for C-plane / Stolen for U-plane;
- f) Stolen for U-plane / Stolen for C-plane;
- g) Stolen for U-plane / Stolen for U-plane.

In case a), and if the BS allows U-plane DTX, the MS may decide not to transmit in the slot, based on the "half slot importance" of the two half slots. If the MS transmits in the slot then normal training sequence 1 shall be used, with a full slot of TCH (MAC-TRAFFIC PDU). In all the other cases, normal training sequence 2 shall be used and the stealing procedure described in clause 23.8.4 shall apply.

In cases b) and c), for a speech call or unprotected data, the upper MAC shall issue a half slot of STCH and a half slot of TCH to the lower MAC. In cases d), e), f) and g), for a speech call or unprotected data, the upper MAC shall issue two half slots of STCH to the lower MAC.

In cases b) and c), for a circuit mode data call with low or high protection, the upper MAC shall issue both a half slot of STCH and a full slot of TCH to the lower MAC. In cases d), e), f) and g), for a circuit mode data call with  $N = 1$ , the upper MAC shall issue two half slots of STCH to the lower MAC. In cases d), e), f) and g), for a circuit mode data call with  $N = 4$  or  $8$ , the upper MAC shall issue two half slots of STCH and also a full slot of TCH to the lower MAC.

NOTE 1: Not stolen + Stolen for C-plane is not a permitted combination.

If the MAC receives Not stolen + Stolen for U-plane from the U-plane application, it could use case e), replacing the traffic with a dummy C-plane message (containing no TM-SDU). However, this would make inefficient use of the channel. It is recommended that the U-plane application does not request this form.

NOTE 2: In an implementation, it may be preferred that (when practicable) the MAC informs the U-plane application as soon as it knows that it will perform C-plane stealing. For example, for a high priority C-plane message, the MAC may intend to steal irrespective of the U-plane half slot importance.

NOTE 3: The above procedure specifies that, for protected circuit mode data with stealing in a slot, the upper MAC may issue both the STCH and a full slot of TCH to the lower MAC. This is because, for protected circuit mode data, the lower MAC replaces traffic bits with STCH bits after normal coding and interleaving of the TCH (see clause 8). This contrasts with the method for speech, where the second half slot is half-slot interleaved if the first half slot is stolen.

### 23.8.3.2 Interface at receiving MS

At the start of a call, or if the basic service information changes, the receiving MS-MAC shall issue a report to the U-plane application to supply the traffic type, the interleaving depth, the number of slots per frame, a flag indicating whether end-to-end encryption applies and the user device parameter.

The following procedures in this clause shall apply for reception in frames 1 to 17 by an MS that is authorized to receive TCH.

TCH shall be passed to the U-plane application.

U-plane signalling shall be passed to the U-plane application after removal of the 3-bit MAC header.

C-plane STCH shall be processed by the MAC, and any suitably addressed TM-SDUs shall be passed to the LLC.

In all cases, for each half slot, the MS-MAC shall issue the TMD-UNITDATA indication primitive to the U-plane application containing any U-plane information (TCH or STCH) and indicating whether the half slot was stolen for C-plane signalling, stolen for U-plane signalling or not stolen.

For protected circuit mode data, in the case of a slot in which only the first half slot was stolen, the upper MAC should receive a half slot of STCH and a full slot of TCH from the lower MAC. The upper MAC shall issue a TMD-UNITDATA indication primitive to the U-plane application containing the U-plane signalling data (if the first half slot was stolen for U-plane signalling) and shall issue two TMD-UNITDATA indication primitives containing TCH, one for each half slot. For circuit mode data with  $N = 4$  or  $8$ , in the case that both half slots are stolen, the upper MAC should receive two half slots of STCH and a full slot of TCH from the lower MAC. The upper MAC shall issue the appropriate TMD-UNITDATA indication primitive(s) to the U-plane application containing U-plane signalling data (if either half slot was stolen for U-plane signalling) and shall issue two TMD-UNITDATA indication primitives containing TCH.

NOTE 1: For the purposes of the protocol description, in the case of U-plane stealing from circuit mode data with  $N = 1$ : when the U-plane signalling data is delivered to the U-plane application, it is associated with the same half slot as the circuit mode data delivered for that half slot. In any instances for which it is necessary to define the relative order of the two types of data associated with a half slot, it is recommended that the U-plane application considers the U-plane signalling data associated with the half slot to be available before the circuit mode data associated with that half slot.

The same principle applies to circuit mode data with  $N = 4$  or  $8$ . However, the  $N - 1$  traffic frame delay procedure for U-plane signalling also applies, as described below.

For the purposes of the protocol description (see note 3): in the case of U-plane stealing from circuit mode data with  $N = 4$  or  $8$ , the receiving upper MAC shall delay the issuing of the TMD-UNITDATA indication primitive(s) containing the U-plane signalling data by  $N - 1$  traffic frames.



NOTE 2: This procedure for delaying the delivery of signalling data for  $N = 4$  and  $8$  applies only to U-plane stealing (not to C-plane stealing).

The procedure is defined so that the U-plane signalling is delivered to the U-plane application with the same U-plane circuit mode data as when it was given by the sending U-plane application to the sending upper MAC. The need for the procedure arises because the multi-slot interleaving causes the circuit mode data to be delayed by  $N - 1$  traffic frames across a link of the air interface, whereas the U-plane signalling is not delayed.

NOTE 3: For the purposes of the protocol description, the U-plane signalling is delayed in the upper MAC. However, in an implementation, it may be preferred that the upper MAC delivers the U-plane signalling to the U-plane application as soon as it is received. In this case, the U-plane application must delay position-sensitive signalling (such as end-to-end encryption synchronization) before use.

In the case of un-decodeable TCH, the MS-MAC may pass the received data to the U-plane application, but shall set the "half slot condition" parameter appropriately in the TMD-UNITDATA indication primitive.

## 23.8.4 Stealing from circuit mode capacity

### 23.8.4.1 Uplink stealing

#### 23.8.4.1.1 Transmission on uplink STCH

Transmission on STCH shall only be used by an MS that has been authorized to transmit traffic.

The appropriate PDUs for C-plane STCH on the uplink shall be:

- MAC-DATA PDU: first or second half slot;
- MAC-END PDU: second half slot only (final fragment).

The appropriate PDU for U-plane STCH shall be:

- MAC-U-SIGNAL PDU: first or second half slot.

The MAC header of a MAC-U-SIGNAL PDU sent in a first half slot shall indicate whether the second half slot is also stolen, using the second half slot stolen flag. If the second half slot is stolen, it may contain either U-plane or C-plane signalling (as indicated by the first MAC header in the second half slot).

For C-plane stealing within the first half slot, PDU association may be used. The "Length indication" in the last MAC-DATA PDU, or in the only MAC-DATA PDU, in the first half slot shall indicate whether the second half slot is also stolen.

- i) "Length indication"  $\leq 010000_2$ : second half slot not stolen.

Then the second half slot shall contain TCH (MAC-TRAFFIC PDU).

- ii) "Length indication" =  $111110_2$ : second half slot stolen, no fragmentation.

Then the second half slot may contain either U-plane or C-plane signalling (as indicated by the first MAC header in the second half slot). For C-plane signalling, PDU association may be used within the second half slot.

- iii) "Length indication" =  $111111_2$ : second half slot stolen, start of fragmentation.

Then the final fragment shall be sent in the second half slot (except in case of cancellation), using the MAC-END PDU. If PDU association is used within the second half slot, then the fragment shall be sent as the first PDU in the MAC block.

After transmitting a C-plane TM-SDU, the MS-MAC shall report to the LLC that the message has been sent by stealing (using the TMA-REPORT indication primitive).

### 23.8.4.1.2 Criteria for uplink stealing

When an MS is authorized to transmit traffic, the MS-MAC may steal from the traffic capacity to send C-plane signalling. The MS then sends C-plane signalling instead of the data received from the U-plane application. The MS-MAC shall not move the replaced U-plane data (neither traffic nor signalling) to a different half slot or slot.

The MS-MAC should report C-plane stealing to the U-plane application, enabling the application to revise the intended use of subsequent half slots, or to retransmit any U-plane signalling that has been overwritten by the MAC.

The following procedures shall apply for the different settings of the stealing permission parameter for the C-plane message.

a) Steal immediately

The MS-MAC shall send the C-plane message at the first opportunity on the uplink assigned channel, without regard to the half slot importance. This rule shall apply to both one- and two-half-slot messages.

For this setting of the stealing permission parameter, and if the MS is authorized to transmit traffic, the MS-MAC shall use stealing in preference to using random access or reserved access on frame 18.

b) Steal within time T.214

If the MS has not been granted a reserved subslot or slot in frame 18 (i.e. in the uplink SACCH for this channel) then the MS-MAC shall send the message within the next T.214 traffic slots on the uplink assigned channel (i.e. within the next T.214 TDMA frames 1 to 17 for a single-slot channel). This rule shall apply to both one- and two-half-slot messages.

The MS-MAC should send the message in the first slot for which the half slot importance is not "high". Or, if this does not occur within T.214 - 1 slots, the MS-MAC shall send the message in the T.214<sup>th</sup> traffic slot on the uplink assigned channel, without regard to the half slot importance.

c) Steal when convenient

The MS designer should choose suitable criteria for deciding when the MS-MAC may steal, based on the priority of the C-plane message, the half slot importance and the time since the last stealing occurrence. It is recommended that the MS-MAC does not re-steal over U-plane signalling.

d) Stealing not required

The MS-MAC should not use stealing to send the message (unless the half slot importance of the traffic is set to "no importance").

The MS designer should see note that frequent stealing would degrade the quality of the circuit.

NOTE 1: The stealing permission parameter should be set to "steal immediately" for U-TX-CEASED (and U-DISCONNECT if currently transmitting traffic). The stealing permission parameter should be set to "steal within time T.214" for the reply to a BS message received while the MS is transmitting traffic, e.g. for a layer 2 acknowledgement.

NOTE 2: For "steal within time T.214", the MS-MAC may plan when to steal based on the stealing permission parameter in the DATA-IN-BUFFER signal from the LLC. The MAC should not issue the MAC-READY signal until it is actually ready to send the message, thereby allowing the maximum time if the layer 3 in the MS is preparing a response to the BS message.

### 23.8.4.1.3 Stealing repeats mechanism

When the MS-MAC has used stealing to transmit a C-plane PDU with stealing permission parameter = "steal immediately", it shall check the setting of the "stealing repeats flag" in the TMA-UNITDATA request primitive. For a message with stealing permission parameter  $\neq$  "steal immediately", or if this flag is not set, the MS-MAC shall regard the requested procedure as complete and shall discard the TM-SDU, i.e. it shall use the normal procedure.

A special procedure shall apply for a message with "steal immediately" if the stealing repeats flag is set.

Then the MS-MAC shall repeat the message on STCH, sending the message once per frame in successive traffic frames (i.e. frames 1 to 17) on the assigned uplink channel, until either:

- a) it has sent the message N.214 times (including the first transmission); or
- b) it has stopped transmitting traffic, e.g. as a result of a higher layer message or after AACH checks; or
- c) it receives a TMA-CANCEL request primitive from the higher layers instructing it to abort transmission of the message.

In cases a) and b), the MS-MAC shall regard the requested procedure as complete and shall discard the TM-SDU. In case c), the MS-MAC shall cease attempting to send the message and shall discard the TM-SDU (see also clause 23.5.3).

While the MS-MAC is performing the "stealing repeats" mechanism described above, it shall over-ride the normal monitoring pattern information, and shall attempt to receive and decode the downlink assigned channel in every frame. For a multi-slot channel, and if the MS is not frequency full duplex, the MS shall transmit only in the lowest numbered uplink slot appropriate to the assigned channel, sending its message in that slot. It shall attempt to receive and decode at least the lowest numbered downlink slot appropriate to the assigned channel in all frames 1 to 17, and all slots appropriate to the assigned channel in frame 18 (within the constraints of linearization and transmission requirements).

If the MS-MAC stops the requested procedure on criterion a) or c) above then it shall continue to use the modified rules for receiving and decoding the downlink channel for the T.251 frames following the N.214<sup>th</sup> transmission of the message.

NOTE 1: The stealing repeats flag may be used by the higher layers to trigger this special stealing method in the MAC. This method is intended for signalling at the end of an uplink traffic transmission, for U-TX-CEASED or possibly U-DISCONNECT. It provides a faster procedure for signalling the end of traffic transmission in case of propagation errors. Firstly, it allows more frequent repeats of the message. Also, the method of modifying the normal monitoring pattern and the structure of a multi-slot channel enables a faster response from the BS.

NOTE 2: This special procedure affects MAC operation only; the LLC re-transmission protocol is unchanged. The MAC should issue the TMA-REPORT indication to the LLC only after the first transmission of the message.

### 23.8.4.1.4 Reception on uplink STCH

This clause describes the procedure for BS reception on uplink slots that have been assigned for traffic.

The training sequence in each slot shall indicate whether stealing has occurred.

For normal training sequence 1 (i.e. SF = 0), the receiving BS shall assume that the slot contains only TCH.

For normal training sequence 2 (i.e. SF = 1), the first half slot shall be assumed to be STCH. Then the MAC PDU type shall indicate whether the first half slot was stolen for C-plane signalling (MAC-DATA PDU) or for U-plane signalling (MAC-U-SIGNAL PDU). The receiving BS shall inspect the MAC header(s) to discover whether the second half slot is also stolen.

- For U-plane signalling, the "second half slot stolen flag" shall indicate whether the second half slot is stolen.
- For C-plane signalling, PDU dissociation may be necessary within the first half slot.
- If the last PDU (or only PDU) in the first half slot is a MAC-DATA PDU containing "Length indication" not equal to 11110<sub>2</sub> nor 11111<sub>2</sub>, then the BS shall assume that the second half slot is not stolen.

- If the last PDU (or only PDU) in the first half slot is a MAC-DATA PDU containing "Length indication" = 111110<sub>2</sub> or 111111<sub>2</sub>, the BS shall assume that the second half slot is stolen. Also, for "Length indication" = 111111<sub>2</sub>, the BS shall assume the start of fragmentation and shall store the TM-SDU fragment.

If the second half slot is not stolen, the BS shall interpret the second half slot as TCH.

If the second half slot is stolen, the BS shall interpret the second half slot as STCH. Then the MAC PDU type shall indicate whether the second half slot was stolen for C-plane signalling (MAC-DATA or MAC-END PDU) or for U-plane signalling (MAC-U-SIGNAL PDU). For C-plane signalling, PDU dissociation may be necessary within the second half slot.

In the case of fragmentation: If the second half slot is not decodeable, or if the second half slot does not include a MAC-END PDU, then the BS should discard the first fragment. Otherwise, it shall append the fragment from the MAC-END PDU to the already received fragment and shall assume that the received TM-SDU is complete.

## 23.8.4.2 Downlink stealing

### 23.8.4.2.1 Transmission on downlink STCH

The BS may steal from a traffic circuit to send C-plane signalling messages on the downlink, either to the MS(s) receiving the traffic or to other MSs on the channel. However, the BS designer should see note that frequent stealing would degrade the quality of the circuit, especially for circuit mode data calls. Also, it is recommended that, when the BS requires to steal, it steals from TCH in preference to overwriting U-plane signalling. This recommendation applies particularly to end-to-end encrypted calls.

Valid PDUs for C-plane STCH on the downlink are:

- MAC-RESOURCE PDU: first or second half slot;
- SYSINFO PDU: first or second half slot;
- ACCESS-DEFINE PDU: first or second half slot;
- MAC-END PDU: second half slot only (final fragment).

The appropriate PDU for U-plane STCH is:

- MAC-U-SIGNAL PDU: first or second half slot.

The downlink MAC-U-SIGNAL PDU should be identical to that received from the transmitting station, except that the setting of the "second half slot stolen flag" may be changed when appropriate.

The MAC header of a MAC-U-SIGNAL PDU sent in a first half slot shall indicate whether the second half slot is also stolen, using the second half slot stolen flag. If the second half slot is stolen, it may contain either U-plane or C-plane signalling (as indicated by the first MAC header in the second half slot).

For C-plane stealing within the first half slot, PDU association may be used. The PDU type or "Length indication" in the last PDU (or only PDU) in the first half slot shall indicate whether the second half slot is also stolen.

- TMB-SAP PDU (SYSINFO or ACCESS-DEFINE): second half slot not stolen.

Then the second half slot shall contain TCH (MAC-TRAFFIC PDU).

- MAC-RESOURCE PDU with "Length indication"  $\leq$  010000<sub>2</sub>: second half slot not stolen.

Then the second half slot shall contain TCH (MAC-TRAFFIC PDU).

- MAC-RESOURCE PDU with "Length indication" = 111110<sub>2</sub>: second half slot stolen,

no fragmentation.

Then the second half slot may contain either U-plane or C-plane signalling (as indicated by the first MAC header in the second half slot). For C-plane signalling, PDU association may be used within the second half slot.

- iv) MAC-RESOURCE PDU with "Length indication" = 11111<sub>2</sub>: second half slot stolen,  
start of fragmentation.

Then the final fragment should be sent in the second half slot, using the MAC-END PDU. PDU association may be used within the second half slot.

NOTE 1: The BS may use the Null PDU as a dummy C-plane message on STCH, in either the first half slot, second half slot or both. As always, "Address type" 000<sub>2</sub> in the MAC-RESOURCE PDU indicates a downlink Null PDU. In the first half slot, the "Length indication" indicates whether or not the second half slot is stolen.

NOTE 2: The SYSINFO PDU cannot be sent in the first half slot if the second half slot is also to be stolen.

If the second half slot is to be stolen, the ACCESS-DEFINE PDU can be included in the first half slot if required, but not as the last PDU (or only PDU) in the first half slot.

#### 23.8.4.2.2 Reception on downlink STCH

This procedure shall be used by all MSs that are receiving the downlink channel.

All MSs that are receiving the channel shall check whether C-plane messages are addressed to itself and, if so, shall process the message and deliver any TM-SDU to the LLC. Only MSs that are currently permitted to process received traffic shall pass the TCH, and the TM-SDU in U-plane signalling (MAC-U-SIGNAL PDU), to the U-plane application.

The training sequence in each slot shall indicate whether stealing has occurred.

For normal training sequence 1 (i.e. SF= 0 ), the receiving MS shall assume that the slot contains only TCH.

For normal training sequence 2 (i.e. SF= 1 ), the first half slot shall be assumed to be STCH. Then the MAC PDU type shall indicate whether the first half slot was stolen for C-plane (TMA-SAP/TMB-SAP) or for U-plane (TMD-SAP) signalling. The receiving MAC shall inspect the MAC header(s) to discover whether the second half slot is also stolen.

- For U-plane signalling, the "second half slot stolen flag" shall indicate whether the second half slot is stolen.
- For C-plane signalling, PDU dissociation may be necessary within the first half slot.
- If the last PDU (or only PDU) in the first half slot is a TMB-SAP PDU, or a MAC-RESOURCE PDU (or Null PDU) containing "Length indication" not equal to 11110<sub>2</sub> nor 11111<sub>2</sub>, then the MS shall assume that the second half slot is not stolen.
- If the last PDU (or only PDU) in the first half slot is a MAC-RESOURCE PDU (or Null PDU) containing "Length indication" = 11110<sub>2</sub> or 11111<sub>2</sub>, the MS shall assume that the second half slot is stolen. Also, for "Length indication" = 11111<sub>2</sub>, the addressed MS(s) shall assume the start of fragmentation and shall store the TM-SDU fragment.

If the first half slot is not decodeable, the MS designer should choose an appropriate method for processing the second half of the slot.

**EXAMPLE** For example, the MS might make a first assumption that the second half slot is stolen, but revise that decision if the CRC fails. (This method could be particularly useful at the start of an encrypted transmission when encryption synchronization might be sent in both halves of the slot.) Otherwise the MS could treat the second half slot as "CRC fail" TCH.

If the second half slot is not stolen, the receiving MS shall interpret the second half slot as TCH.

If the second half slot is stolen, the MS shall interpret the second half slot as STCH. Then the MAC PDU type shall indicate whether the second half slot was stolen for C-plane (TMA-SAP/TMB-SAP) or U-plane (TMD-SAP) signalling. If the second half slot is not decodeable, the MS should regard the MAC block as C-plane signalling with CRC failure.

In the case of C-plane signalling, PDU dissociation may be necessary within the second half slot.

If the second half slot is not decodeable, or if the second half slot does not include a MAC-END PDU, an MS-MAC that stored a first fragment in the first half slot shall discard that fragment. Otherwise, it shall append the fragment from the MAC-END PDU to the already received fragment, and shall deliver the complete TM-SDU to the LLC.

## 23.8.5 BS operation

For traffic slots received on the uplink:

- a) for normal training sequence 1, channel decoding (and re-encoding) may be performed at the BS, allowing error correction for multiple hops;
- b) channel decoding (and re-encoding) should be performed at the BS in the case of normal training sequence 2, in order that the BS can recognize C-plane stealing;
- c) when a half slot has been stolen on the uplink for C-plane signalling, the BS should replace the stolen half slot (e.g. with another C-plane message or with the Null PDU or with substitution traffic) before transmission on the downlink.

The BS should pass the U-plane signalling and TCH on towards the destination. The timing and ordering and half-slot pairing of the U-plane information (signalling and TCH) shall be preserved. The BS may replace (i.e. overwrite) U-plane information when performing C-plane stealing, but shall not move the replaced U-plane information to a different position.

If the BS does not receive data from the sending MS, e.g. in the case of U-plane DTX, it should still transmit on the downlink channel to the receiving MS(s). For example, it could fill the slot with two stolen half slots each containing the C-plane Null PDU, or it could fill the slot with substitution traffic.

If the BS is decoding and re-encoding the traffic for a circuit mode data call with an interleaving depth of  $N = 4$  or  $8$  then:

- i) the BS should delay U-plane signalling by  $N - 1$  traffic frames before transmission on the downlink;

NOTE 1: This procedure for  $N = 4$  or  $8$  means that the BS transmits the U-plane data stream with the U-plane signalling in the same position as when the MS transmitted it. This position may be important if the U-plane signalling is carrying end-to-end encryption synchronization.

The need for the procedure arises because the de-interleaving process causes the circuit mode data to be delayed by  $N - 1$  traffic frames relative to the U-plane signalling. The receiving MS's procedure (see clause 23.8.3.2) takes account of the relative delay over the air interface if the BS does not de-interleave the traffic before transmission on the downlink. The BS needs to compensate for the additional relative delay introduced by its de-interleaving and re-interleaving of the traffic.

- ii) after a U-TX CEASED or U-DISCONNECT PDU has been received from the transmitting MS, the BS should ensure that it has been able to issue  $N - 1$  slots containing tail bits to the lower MAC at the end of the data transmission (on each allocated slot in the case of a multi-slot channel) before sending the D-TX CEASED, D-RELEASE or D-DISCONNECT PDU to receiving MS(s).

NOTE 2: These tail bits are needed to complete the interleaving of the circuit mode data that has been received from the transmitting MS.

Some examples of scenarios for call set-up and channel usage for circuit mode calls are illustrated in annex D.

---

24 (Void)

Figure 150 to figure 157 (Void)

Table 350 (Void)

---

25 (Void)

Figure 158 to figure 161 (Void)

**Table 351 (Void)**

---

**26 (Void)****Figure 162 to figure 166 (Void)****Table 352 and table 353 (Void)**

---

**27 (Void)****Figure 167 to figure 179 (Void)****Table 354 to table 357 (Void)**

---

## **28 TETRA Packet Data Protocol**

This clause defines TETRA Packet Data Protocol (PDP) for packet data operation. TETRA PDP extends the data communication services by providing extended capacity and usability for TETRA. The TETRA packet data service is separate from the Connection Oriented Network Service (CONS) and the Specific Connectionless Network Service (SCLNS) which are defined in clauses 24 to 27 of the ETS 300 392-2 edition 1. The TETRA packet data service is built on top of the Mobile Link Entity (MLE) defined in clauses 17 and 18 of the present document.

The TETRA packet data service provides mechanisms to convey different higher layer protocols. The present document supports the following network layer protocols:

- Internet Protocol (IP), versions 4 and 6.

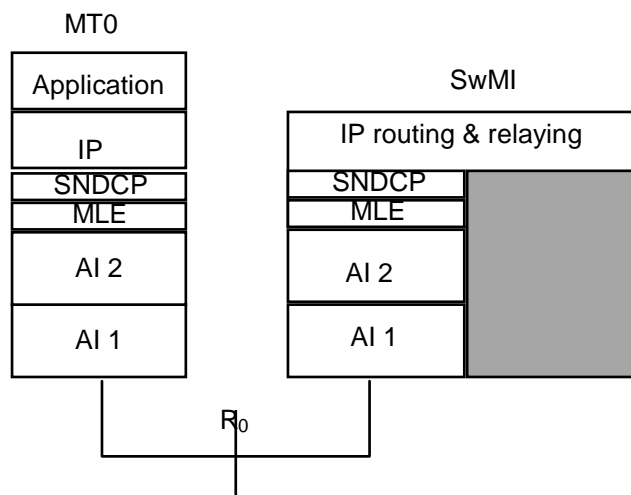
TETRA packet data extends TETRA to act as an IP subnet. This enables application programmers to build their applications in a well-standardised environment.

At the MS side the IP and the higher layers on top of it may be located at:

- MT0;
- TE2 where the protocol used between TE2 and MT2 is defined in EN 300 392-5 [47];
- TE where the protocol used between TE and MT0 is outside the scope of the present document and EN 300 392-5 [47];

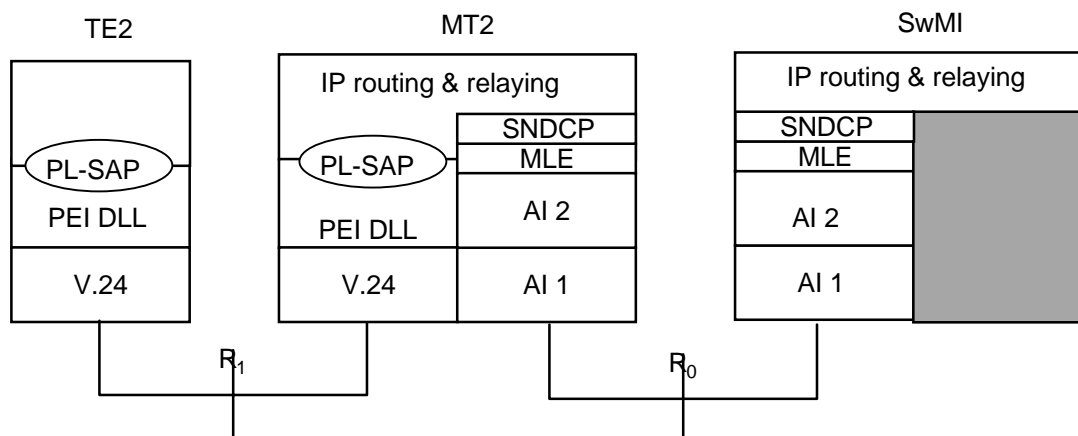
The implementation of SwMI's IP routing and relaying as well as the connection to external networks is outside the scope of the present document.

The figure 180 illustrates the usage of TETRA packet data when the application uses IP protocol and it is located in MT0.



**Figure 180: Usage of TETRA packet data for MT0 IP application**

The figure 181 illustrates the usage of TETRA packet data when the application uses IP protocol and it is located in TE2. PEI DLL (MT2) services are provided to the MT2 IP signalling and relaying entity at PL-SAP. Only a single instance of PL-SAP shall exist. All protocols using PEI DLL are multiplexed to the same SAP and distinguished by a protocol number. Mapping between PEI DLL (MT2) PL-SAP and SNDCP SN-SAP is outside the scope of the present document.



**Figure 181: Usage of TETRA packet data for TE2 IP application**

The Wireless Application Protocol (WAP) architecture, see [39], defines a framework to meet the challenges of the advanced services, differentiation and fast/flexible service creation in wireless networks. The WAP defines a set of protocols in transport, session and application layers.



The upper layers of WAP will be independent of the underlying wireless network, while the transport layer should be adapted to specific features of underlying services. This adaptation to TETRA packet data is, however, outside of the scope of the present document. When used in conjunction with the TETRA packet data service, it is recommended that WAP be located on top of UDP/IP. Figure 182 illustrates the recommended usage of TETRA packet data when the application is a WAP application and it is located in MT0.

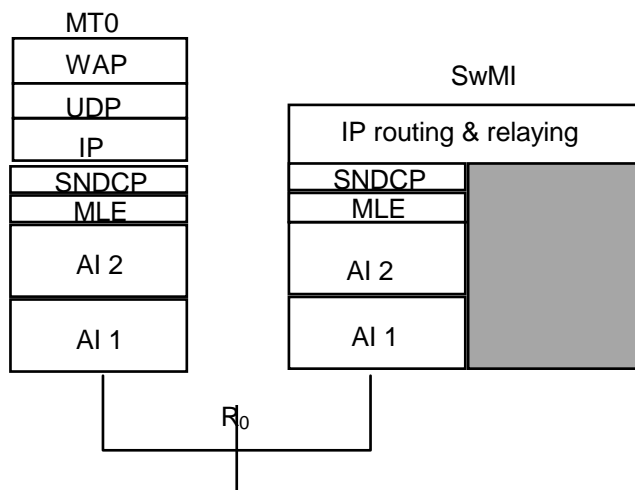


Figure 182: Usage of TETRA packet data for MT0 WAP application

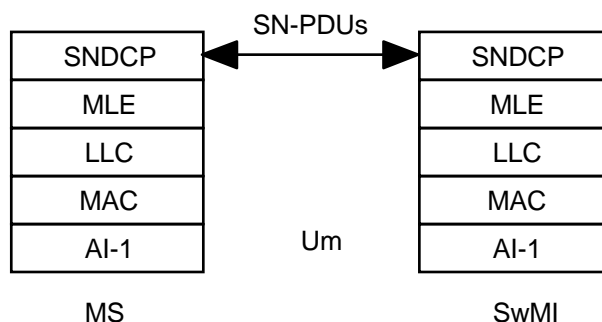
## 28.1 Subnetwork Dependent Convergence Protocol (SNDCP) overview

The Subnetwork Dependent Convergence Protocol (SNDCP) is a TETRA specific network layer protocol that has two main functions:

- 1) to negotiate and maintain PDP contexts between an MS and the SwMI. A unique PDP context is established for each PDP address active (i.e. which requires packets to be routed to it) on the network. The PDP context activation procedure involves the binding of a PDP address to a TETRA ITSI and also the optional negotiation of compression algorithms to be used during data transfer.
- 2) to control PDP data transfer between MS and SwMI. Data transfer is unacknowledged (i.e. SNDCP does not perform retransmissions) however SNDCP allows the service user to select the acknowledged or unacknowledged layer 2 services for data transfer over the air interface. SNDCP provides mechanisms by which data may be compressed before transmitted over the air interface.

NOTE: The unacknowledged layer 2 service is not available for packet data transfer on the uplink.

Figure 183 describes the protocol model for TETRA packet data and the SNDCP position in it.



**NOTE: Legend:**

Subnetwork Dependent Convergence Protocol (SNDCP): TETRA specific Network layer protocol that shall be used to negotiate and maintain PDP context between MS and SwMI

Mobile Link Entity (MLE): MLE protocol discriminator entity (data transfer) routes TETRA Packet data signalling and data to corresponding TETRA Packet data SAP at the peer entity (SwMI/MS).

Logical Link Control (LLC): This layer provides a logical link.

Medium Access Control (MAC): This controls the access signalling (request and grant) procedures for the radio channel, and the mapping of LLC frames onto the TETRA physical channel.

Air Interface layer 1 (AI-1): As defined in the present document.

**Figure 183: Subnetwork Dependent Convergence Protocol (SNDCP)**

Before a MS may gain access to any SNDCP services, it firstly goes through a packet data registration procedure, called PDP Context Activation. Context Activation is initiated by the MS. PDP Context Activation involves the negotiation of a PDP address (e.g. an IPv4 address) and other parameters to be used during data transfer.

PDP data transfer normally takes place over an assigned secondary control channel (assigned SCCH), termed in this specification, a Packet Data CHannel (PDCH). An advanced link is set up before data transfer may begin on the PDCH. When a MS has data to transfer, it implicitly requests permission to switch to the PDCH. If accepted, the SwMI responds with a channel allocation, directing the MS to a PDCH.

The protocol for SNDCP is described in terms of a state machine. There are three main states which are defined for both the MS and SwMI, namely READY, STANDBY and IDLE.

READY state typically implies a MS is located on a PDCH and is currently engaged in data transfer or has recently (defined by a timer) been engaged in packet data transfer.

STANDBY state implies a MS is no longer on a PDCH i.e. the MS has not recently (defined by a timer) been engaged in data transfer.

IDLE state implies that a MS has no PDP contexts activated.

A more complete description of SNDCP is given in the following clauses.

## 28.2 SNDCP service description

### 28.2.1 Introduction

This sub-clause describes the services offered by the Subnetwork Dependent Convergence Protocol (SNDCP) entity for the voice plus data TETRA layer 3 air interface.

### 28.2.2 Services offered

SNDCP shall be a service provider for packet data users. The services shall be made available through the SNDCP Service Access Point (SN-SAP). The SNDCP procedures and protocol description are defined in clauses 28.3 and 28.4.

The services offered shall be:

- PDP context activation and PDP context deactivation;
- Packet Data CHannel (PDCH) handling;
- Multiplexing of N-PDUs from one or several higher protocol entities onto a single layer 2 connection;
- Mapping of SN primitives received from the network layer into corresponding MLE-UNITDATA primitives to be passed to the MLE;
- Management of the delivery sequence according to the PDU priority of SN-UNITDATA and SN-DATA primitives;
- Compression and recovery of redundant protocol control information (e.g. TCP/IP header). Header compression is performed independently for each NSAPI;
- Compression and recovery of redundant user data. Data compression is performed independently for each NSAPI.

### 28.2.3 Service Primitives

The services shall be provided through primitives at the service access point SN-SAP. This clause describes the primitives and their parameters.

Mapping of various protocols to the SNDCP operation is defined with respect to an abstract underlying service. The underlying service consists of the following primitives:

- SN-DATA {Request, Indication};
- -SN-DELIVERY {Indication};
- SN-NSAPI ALLOC {Request, Confirmation, Indication};
- SN-NSAPI DEALLOC {Request, Indication};
- SN-QOS {Request, Indication};
- SN-UNITDATA {Request, Indication};
- SN-PAGE { Request, Confirmation, Response, Indication}.

### 28.2.3.1 Primitive descriptions

In parameter descriptions:

- M = Mandatory:
- O = Optional:
- - = Not allowed.

**SN-DATA request/indication:** SN-DATA primitive is used for acknowledged data transfer service at the LLC. The receipt of data shall be confirmed by the LLC layer.

Parameters of the primitive shall be as shown in table 358.

**Table 358: Parameters for the primitive SN-DATA**

Parameter	Request	Indication
NSAPI	M	M
Handle	M	-
PDU priority	O (see note)	-
N-PDU	M	M
NOTE: If PDU priority is not given in the primitive, then the value assigned by the SwMI during context activation is used.		

**SN-DELIVERY indication:** SN-DELIVERY primitive is used to indicate that the layer 2 has completed its transmission of a SN-DATA request (success/failure) and SN-UNITDATA request (failure).

Parameters of the primitive shall be as shown in table 359.

**Table 359: Parameters for the primitive SN-DELIVERY**

Parameter	Indication
Handle	M
Delivery report	M

**SN-NSAPI ALLOC request/indication/confirm:** SN-NSAPI ALLOC primitive is used to set NSAPI into use.

Parameters of the primitive shall be as shown in table 360.

**Table 360: Parameters for the primitive SN-NSAPI ALLOC**

Parameter	Request (MS only)	Indication (SwMI only)	Confirm (MS only)
NSAPI	M	M	M
NSAPI alloc report	-	-	M
PDP type	M	M	C (see note 3)
PDP address	C (see note 1)	M	C (see note 2, see note 3)
DCOMP negotiation	O	O	O (see note 3)
PCOMP negotiation	O	O	O (see note 3)
NSAPI alloc reject cause	-	-	C (see note 4)
PDU priority max	-	-	C (see note 3)
Maximum transmission unit	-	-	M
Mobile IPv4 information	-	-	C (see notes 3 and 5)
NOTE 1: Conditional on PDP type. PDP address not present in case of IPv4 dynamic address negotiation or IPv6.			
NOTE 2: Conditional on PDP type. PDP address not present in case of IPv6 or Mobile IPv4 FA care of address requested.			
NOTE 3: Conditional on NSAPI alloc report. Not present in case of NSAPI alloc report set to "Failure".			
NOTE 4: Conditional on NSAPI alloc report. Present in case of NSAPI alloc report set to "Failure".			
NOTE 5: Conditional on PDP type. Present if PDP type set to Mobile IPv4.			

**SN-NSAPI DEALLOC request/indication:** SN-NSAPI DEALLOC primitive is used to withdraw NSAPI from use.

Parameters of the primitive shall be as shown in table 361.

**Table 361: Parameters for the primitive SN-NSAPI DEALLOC**

Parameter	Request	Indication
Deactivation type	M	M
NSAPI	C (see note)	C (see note)
NOTE:	Not present if Deactivation Type is set to "Deactivate All NSAPIs".	

**SN-QOS request/indication:** SN-QOS primitive is used to negotiate about QoS to the peer entity.

Parameters of the primitive shall be as shown in table 362.

**Table 362: Parameters for the primitive SN-QOS**

Parameter	Request	Indication
QoS requested	M	M
QoS minimum	M	-
QoS negotiated	-	M
QoS negotiation result	-	M
NOTE:	It is recommended that this primitive is used only to set parameters within the MS SMDCP entity, to be used at a later stage during advanced link setup negotiation. This primitive should not in itself trigger the establishment or resetting of the advanced link.	

**SN-UNITDATA request/indication:** SN-UNITDATA primitive is used for unacknowledged data transfer service at the LLC. The receipt of data is not confirmed by the SMDCP or lower layers.

Parameters of the primitive shall be as shown in table 363.

**Table 363: Parameters for the primitive SN-UNITDATA**

Parameter	Request (SwMI only)	Indication (MS only)
NSAPI	M	M
Handle	M	-
PDU priority	O (see note)	-
N-PDU	M	M
NOTE:	If PDU priority is not given in the primitive, then the value assigned during context activation is used.	

**SN-PAGE request/indication/response/confirm:** SN-PAGE primitive is used as part of the TETRA packet data paging mechanism.

Parameters of the primitive shall be as shown in table 364.

**Table 364: Parameters for the primitive SN-PAGE**

Parameter	Request (SwMI only)	Indication (MS only)	Response (MS only)	Confirm (SwMI only)
NSAPI	M	M	M	M
Reply requested	M	M	-	-
PD service status	-	-	M	M

### 28.2.3.2 Parameter descriptions

DCOMP negotiation =

This parameter may contain several different data compression methods, such as ITU-T Recommendation V.42bis [19], and their parameters negotiated with the peer entity.

Deactivation type =

Deactivate all NSAPIs;

Deactivate NSAPI given in the primitive.

Delivery report =

Success;

Failure.

Handle =

Defines the handle used to generate a mapping between SN-Data or SN-Unitdata requests and SN-Delivery report indications.

Maximum transmission unit =

This is the maximum size of N-PDU which may be presented by the MS service user to SNDCP, for transport over the air interface. This typically represents the maximum size of IP datagram (prior to adding SNDCP header and performing compression) which may be carried over the air-interface.

Mobile IPv4 Information =

Information specific to Mobile IPv4 operation.

N-PDU =

Any number of bits needed to carry a Network layer protocol PDU.

NSAPI =

0 Reserved;

1 Free;

...

14 Free;

15 Reserved.

NSAPI alloc reject cause =

- Any reason;
- MS not provisioned for Packet Data;
- IPv4 not supported;
- IPv6 not supported;
- IPv4 dynamic address negotiation not supported;
- Dynamic address pool empty;
- Static address not correct;
- Static address in use;
- Static address not allowed;
- Static IP address congestion;
- TETRA Packet Data not supported on this location area;
- TETRA Packet Data not supported on this network;
- Temporary rejection;
- Packet Data MS Type not supported;
- SNDCP version not supported;
- Mobile IPv4 not supported;
- Mobile IPv4 Co-located Care of Addresses not supported;
- Maximum allowed PDP contexts per ITSI exceeded;
- No response from network;
- Bad response from network.

NSAPI alloc report =

- Failure;
- Success (Note that DCOMP negotiation and PCOMP values might be changed).

PCOMP Negotiation =

This parameter may contain several different protocol compression methods.

PD service status =

- Available for packet data service;
- Temporarily unavailable for packet data service.

PDP type =

- IPv4 (static address);
- IPv4 (dynamic address negotiation);
- IPv6;
- Mobile IPv4 - Foreign Agent care of address requested;
- Mobile IPv4 - Co-located care of address requested.

PDP address =

The presence of the PDP address field and the contents of this field if present shall be conditional on the value of the PDP type field. Where present this field shall contain an IPv4 address.

PDU priority =

0 Lowest PDU priority;

...

7 Highest PDU priority.

PDU priority max =

As PDU priority.

QoS requested =

Advanced link service (unacknowledged, acknowledged);

Maximum length of N-PDU;

Number of timeslots used per TDMA frame (1-4);

Data transfer throughput (network dependent minimum, 1/32, 1/16, 1/8, 1/4, 1/2, maximum).

QoS minimum =

As QoS requested.

QoS negotiated =

As QoS requested.

QoS negotiation result =

Success;

Failure;

Failure, try again.

Reply requested =

SNDCP response required;

SNDCP response not required.

## 28.2.4 Definition of SNDCP states and state transitions

The SNDCP activities related to a TETRA MS are characterised by one of eight different SNDCP states: CLOSED, IDLE, IDLE-Temporary Break, STANDBY, STANDBY-Temporary Break, RESPONSE-WAITING, READY and READY-Temporary Break. The SNDCP activities related to a TETRA SwMI are characterised by one of three different SNDCP states: IDLE, STANDBY and READY.

Each state describes a certain level of functionality and information allocated to the involved entities. The SNDCP state relates only to SNDCP activities of a subscriber represented by the ITSI. It is independent of number of PDP contexts for that subscriber.

It is optional for a MS to support multiple PDP contexts. It is also optional for a SwMI to support multiple PDP contexts for a single ITSI.

**NOTE:** If multiple PDP contexts are used by a single ITSI, then the MS will release all its PDP contexts at the same time when entering to state IDLE from state STANDBY. The SwMI may use SwMI originated PDP Deactivation procedure in order to control PDP context lifetimes separately.



### 28.2.4.1 CLOSED

CLOSED state is valid for a MS only. In CLOSED state access to the communication resources is unavailable (e.g. due to MS not being registered) and SNDCP is not permitted to communicate with its peer entity.

In CLOSED state, the MS must not have any PDP contexts active. When entering state CLOSED, the READY, RESPONSE\_WAIT and STANDBY timers are stopped.

On reception of an indication that access to the communication resources has become available (on reception of MLE-OPEN indication from MLE), the MS SNDCP entity shall enter IDLE state.

### 28.2.4.2 IDLE

In IDLE state the MS and SwMI shall not have PDP contexts. When entering to state IDLE, the STANDBY, RESPONSE\_WAIT and READY timers are stopped.

Data transfer to and from the mobile subscriber is not possible. The MS is seen as not reachable in this case for TETRA Packet data.

In order to establish SNDCP contexts in the MS and the SwMI, the MS shall perform the PDP context activation procedure. After successful PDP context activation the MS shall start STANDBY timer and enter to state STANDBY.

On reception of an MLE-BREAK indication from the MLE, the MS SNDCP entity shall enter IDLE-Temporary Break state.

### 28.2.4.3 IDLE-temporary break

IDLE-Temporary Break state is only valid for the MS. This state is only entered while access to the communication resources has become temporarily unavailable (e.g. due to cell reselection). A temporary break in access to the communication resources is signalled to SNDCP by reception of the MLE-BREAK indication primitive from the MLE.

Network selection and initial cell selection and reselection processes are performed by the MS based on V+D procedures. The criteria to select a new cell should also contain weight for advanced link support in the cell.

This state shall be entered from IDLE state on reception of an MLE-BREAK indication. This state shall also be entered from STANDBY-Temporary Break state when the STANDBY timer expires. On entering this state from STANDBY-Temporary Break, all PDP contexts shall be locally deactivated.

In IDLE-Temporary Break state the MS and SwMI shall not have PDP contexts.

Communication between the MS and SwMI SNDCP entities is not possible in this state.

On reception of an MLE-RESUME indication from the MLE, the MS SNDCP entity shall enter IDLE state.

### 28.2.4.4 STANDBY

In STANDBY state, the subscriber has at least one PDP context activated.

The MS may receive and respond to SN-PAGE REQUEST PDUs while in this state.

The MS may initiate activation of a new PDP context while in STANDBY state.

The MS may initiate deactivation of PDP contexts while in STANDBY state. After deactivation of the last PDP context the STANDBY timer is stopped and SNDCP state is changed to IDLE. The SNDCP entity shall issue MLE-DISCONNECT request to the MLE in order to disconnect the logical link, if any.

On reception of a SN-DATA request primitive from the service user, the MS SNDCP entity shall transmit a SN-DATA TRANSMIT REQUEST PDU. On transmission of a SN-DATA TRANSMIT REQUEST PDU, the MS SNDCP entity shall send an MLE-ACTIVITY request with sleep mode set to "stay alive", start the RESPONSE\_WAIT timer and enter RESPONSE-WAITING state. The STANDBY timer is not stopped on entering RESPONSE-WAITING state. On reception (MS only) or transmission (SwMI only) of a SN-ACTIVATE PDP CONTEXT ACCEPT PDU the SNDCP entity shall restart the STANDBY timer.

The STANDBY timer is stopped, the READY timer is started and the SNDTCP state is changed to READY on transmission of (SwMI only) or reception of (MS only) SN-DATA TRANSMIT REQUEST PDU. Where the MS receives a group addressed SN-DATA TRANSMIT REQUEST PDU, on moving to READY state the MS shall not start the READY timer. The READY timer is not activated when a MS enters READY state for reception of point to multipoint packet data.

On transmission of a SN-DATA TRANSMIT RESPONSE PDU with Accept/Reject = 1 (i.e. Request accepted), the SwMI SNDTCP entity shall stop the STANDBY timer, start the READY timer and enter READY state.

On transmission of a SN-DATA TRANSMIT RESPONSE PDU with Accept/Reject = 0 (i.e. Request rejected), the SwMI SNDTCP entity shall remain in STANDBY state.

If the STANDBY timer expires, the PDP contexts in the SwMI and in the MS are deleted independently and the SNDTCP state is changed to IDLE. The SNDTCP entity shall issue a SN-NSAPI DEALLOC indication to the service user having "Deactivation type" parameter set to value "Deactivate all NSAPIs".

Where there is a temporary break in access to the radio communication resources as indicated by the reception of an MLE-BREAK indication from the MLE, the MS SNDTCP entity shall enter STANDBY-Temporary Break state.

If the MS SNDTCP entity has an active SERVICE\_CHANGE timer and it receives a SN-DATA request primitive from the service user, it shall delay the transmission of a SN-DATA TRANSMIT REQUEST PDU and keep the SN-DATA request in its buffers. If the SERVICE\_CHANGE timer expires, the MS SNDTCP entity may continue normal operation and transmit a SN-DATA TRANSMIT REQUEST PDU if necessary.

NOTE: The MS SNDTCP entity should handle other service requests normally regardless of active SERVICE\_CHANGE timer.

#### 28.2.4.5 STANDBY-temporary break

STANDBY-Temporary Break state is only valid for the MS. This state is only entered while access to the communication resources has become temporarily unavailable (e.g. due to cell reselection). A temporary break in access to the communication resources is signalled to SNDTCP by reception of the MLE-BREAK indication primitive from the MLE.

Network selection and initial cell selection and reselection processes are performed by the MS based on V+D procedures. The criteria to select a new cell should also contain weight for advanced link support in the cell.

This state shall be entered from STANDBY state and RESPONSE-WAITING state on reception of an MLE-BREAK indication. This state shall also be entered from READY-Temporary Break state when the READY timer expires.

Communication between the MS and SwMI SNDTCP entities is not possible in this state.

On reception of an MLE-RESUME indication from the MLE, the MS SNDTCP entity shall enter STANDBY state. In case the MNI values in the MLE-RESUME indication primitive do not match with ones in the MLE-OPEN indication primitive, the MS knows that it has changed the network. Therefore it shall enter the IDLE state and may attempt to reactivate the existing PDP contexts by sending SN-ACTIVATE PDP CONTEXT DEMAND PDUs to the SwMI after state transition, otherwise all contexts shall be deactivated locally. After successful PDP context activation the MS shall start the STANDBY timer and enter to state STANDBY.

If the STANDBY timer expires, the PDP contexts are deleted locally and the SNDTCP state is changed to IDLE-Temporary Break. The SNDTCP entity shall issue a SN-NSAPI DEALLOC indication to the service user having "Deactivation type" parameter set to value "Deactivate all NSAPIs".

#### 28.2.4.6 RESPONSE-WAITING

RESPONSE-WAITING state is only valid for the MS. In RESPONSE-WAITING state, the MS has at least one PDP context activated.

The MS SNDTCP entity shall enter RESPONSE-WAITING state from STANDBY state on transmission of a SN-DATA TRANSMIT REQUEST PDU. On entering RESPONSE-WAITING state the STANDBY timer remains active and the RESPONSE\_WAIT timer is started.

The MS SNDCP entity shall also enter RESPONSE-WAITING state from READY-Temporary Break state on reception of an MLE-RESUME indication from the MLE and if there are pending SN-DATA request primitives from the service user. In this case the MS stops the READY timer and starts the RESPONSE\_WAIT and STANDBY timers.

The MS shall not initiate the activation of PDP contexts while in RESPONSE-WAITING state. The MS shall not initiate the deactivation of PDP contexts while in RESPONSE-WAITING state. The MS may respond to a SN-PAGE REQUEST while in RESPONSE-WAITING state.

On reception of a SN-DATA request primitive from the service user, the MS SNDCP entity shall store the request.

On reception of a SN-DATA TRANSMIT REQUEST PDU, the MS shall send an MLE-ACTIVITY request with sleep mode set to "sleep permitted", stop the STANDBY and RESPONSE\_WAIT timers, start the READY timer and enter READY state. Where the MS receives a group addressed SN-DATA TRANSMIT REQUEST PDU, on moving to READY state the MS shall not start the READY timer. The READY timer is not activated when a MS enters READY state for reception of point to multipoint packet data.

On reception of a SN-DATA TRANSMIT RESPONSE PDU with Accept/Reject = 1, the MS shall send an MLE-ACTIVITY request with sleep mode set to "sleep permitted", stop the STANDBY and RESPONSE\_WAIT timers, start the READY timer and enter READY state.

On reception of a SN-DATA TRANSMIT RESPONSE PDU with Accept/Reject = 0, the MS shall send an MLE-ACTIVITY request with sleep mode set to "sleep permitted", stop the RESPONSE\_WAIT timer and return to STANDBY state.

Where the RESPONSE\_WAIT timer expires, the MS shall send an MLE-ACTIVITY request with sleep mode set to "sleep permitted" and return to STANDBY state.

Where the STANDBY timer expires, the RESPONSE\_WAIT timer is stopped, all PDP contexts are deleted locally and the SNDCP state is changed to IDLE. The SNDCP entity shall send an MLE-ACTIVITY request with sleep mode set to "sleep permitted", issue a SN-Dealloc NSAPI indication to the service user having "Deactivation type" parameter set to value "Deactivate all NSAPIs".

Where there is a temporary break in access to the radio communication resources as indicated by the reception of an MLE-BREAK indication from the MLE, the MS SNDCP entity shall send an MLE-ACTIVITY request with sleep mode set to "sleep permitted", stop the RESPONSE\_WAIT and enter STANDBY-Temporary Break state.

Prior to entering states STANDBY, STANDBY-Temporary Break, CLOSED or IDLE from state RESPONSE-WAITING, the MS SNDCP entity shall ensure that all stored SN-DATA request primitives are deleted. For each SN-DATA request primitive deleted, a corresponding notification of failure shall be sent to the service user in the form of a SN-DELIVERY indication primitive.

#### 28.2.4.7 READY

In READY state, the subscriber has at least one PDP context activated.

The MS may receive and transmit datagrams while in this state.

The MS shall enter READY state on reception of a SN-DATA TRANSMIT REQUEST PDU or of a SN-DATA TRANSMIT RESPONSE PDU (with Accept/Reject = 1). The SwMI shall enter READY state on transmission of a SN-DATA TRANSMIT RESPONSE PDU (with Accept/Reject = 1) or of a SN-DATA TRANSMIT REQUEST PDU. On entering READY state, the RESPONSE\_WAIT and STANDBY timers are stopped and the READY timer is started.

In the case where the MS enters READY state after reception of a group addressed SN-DATA TRANSMIT REQUEST PDU, the MS shall not start the READY timer. The READY timer is not activated when a MS enters READY state for reception of point to multipoint packet data.

The READY timer is re-started when a datagram (PTP) is successfully transmitted as indicated by the reception of a MLE-REPORT indication and accordingly, the READY timer is re-started when a datagram is received. In the case of reception of point to multipoint datagrams, the READY timer is not (re)started in the MS.

In addition the SwMI should have some other mechanisms to optimise the usage of the PDCH. Because the transfer delay on the LLC can vary substantially as a function of message length, radio link quality, and other traffic on the PDCH, and because only full datagrams are delivered to the SNDCP, the READY timer does not provide tight control of the stay on the PDCH.

The SwMI may therefore further refine the state transition handling by using the MLE-RECEIVE indication and/or other methods to ensure a timely exit from the READY state (by sending an SN-END OF DATA to the MS). The SwMI may use this indication to optimise the length of the stay on the PDCH and should use this indication to prevent sending SN-END OF DATA while data reception is in progress on the LLC. The optimal procedures for this will depend on SwMI design as well as application behaviour, and is therefore outside the scope of the present document.

The MS may not deactivate PDP contexts while in READY state. To initiate the deactivation of one or more PDP contexts, a MS must return to STANDBY state. On reception of the primitive SN-NSAPI-DEALLOC request from the SMDCP service user, the MS SMDCP entity may attempt to return to STANDBY state prior to the expiry of the READY timer by sending a SN-END OF DATA PDU to the SwMI. The SwMI shall respond to the SN-END OF DATA PDU with a SN-END OF DATA PDU.

NOTE 1: If the MS does not get any response to the SN-END OF DATA PDU from the SwMI after a number of retransmissions and restarts of READY timer, it may return independently to the STANDBY state even before inactivity time-out on assigned SCCH. The number of used retransmissions is an implementation dependent issue and is out of the scope of the present document.

NOTE 2: The MS may also return independently to the STANDBY state without any SN-END OF DATA PDU response if the packet data service is overridden by some other service and the channel change to other channel is needed to do immediately (e.g. in case of emergency service). However, the MS should then send a SN-END OF DATA PDU to the SwMI before the state transition and use the Immediate service change information element to indicate that immediate service change has occurred and therefore the MS has left the PDCH.

The MS may initiate activation of a new PDP context while in READY state. Should this happen the MS shall remain in the state READY.

Regardless if a radio resource is allocated to the subscriber or not, the SMDCP remains in the READY state even when there is no data being communicated. The READY state is supervised by a timer.

When the READY timer expires in the MS, the MS shall send SN-END OF DATA PDU to the SwMI and restart READY timer.

When the READY timer expires in the SwMI, the SwMI shall send SN-END OF DATA PDU to the MS. The SwMI shall also send a SN-END OF DATA PDU in response to reception of a SN-END OF DATA PDU from the MS.

The MS shall stop the READY timer, start the STANDBY timer and enter to state STANDBY on receiving SN-END OF DATA PDU. The SwMI shall enter to state STANDBY when sending SN-END OF DATA PDU. In the case where the MS receives a group addressed SN-END OF DATA PDU, the MS shall reject the channel allocation if the READY timer is active.

NOTE 3: An active READY timer implies the MS is on the PDCH and involved in point to point packet data exchanges. Hence the MS in such a case may not wish to leave READY state.

While a SwMI is required by this specification to respond to a SN-END OF DATA PDU received from a MS, by sending another SN-END OF DATA PDU to the MS, the SwMI may delay sending the SN-END OF DATA PDU until any outstanding data being prepared for transmission on the downlink, has been transmitted if the MS has not indicated immediate service change in the SN-END OF DATA PDU.

NOTE 4: This delay is required due to the MS SMDCP entity having no knowledge of the status of the LLC entity i.e. if it is currently receiving advanced link segments from the SwMI. Hence the MS SMDCP entity may be unaware that the lower layers are currently receiving packet data.

In case the MS indicates the immediate service change in the SN-END OF DATA PDU, the SwMI shall cancel the downlink data transmission immediately and enter to state STANDBY.

In case the SwMI indicates the immediate service change in the SN-END OF DATA PDU, the MS SMDCP entity should stop the READY timer, start the STANDBY timer and SERVICE\_CHANGE timer and enter to state STANDBY.

NOTE 5: If the immediate service change is indicated by the MS, it does not have to wait SN-END OF DATA PDU response from the SwMI before entering to state STANDBY. However, the layer 2 acknowledgement to the SN-END OF DATA PDU sending should be expected before any state transition. Where there is a temporary break in access to the radio communication resources as indicated by the reception of an MLE-BREAK indication from the MLE, the MS SNDPCP entity shall enter READY-Temporary Break state.

NOTE 6: The SwMI should indicate immediate service change only if it is going to send a request to another service to the MS which is capable to handle only one active service at the time. When new service is accepted in this case, the exact SNDPCP functioning is outside the scope of the present document.

The SwMI SNDPCP entity shall stop the READY timer, start the STANDBY timer and enter STANDBY state on reception of the SN-RECONNECT PDU.

#### 28.2.4.8 READY-temporary break

READY-Temporary Break state is only valid for the MS. This state is only entered when access to the communication resources has become temporarily unavailable (e.g. due to cell reselection). A temporary break in access to the communication resources is signalled to SNDPCP by reception of the MLE-BREAK indication primitive from the MLE.

Network selection and initial cell selection and reselection processes are performed by the MS based on V+D procedures. The criteria to select a new cell should also contain weight for advanced link support in the cell.

This state shall be entered from READY state on reception of an MLE-BREAK indication.

Communication between the MS and SwMI SNDPCP entities is not possible in this state.

On reception of an MLE-RESUME indication from the MLE, the MS SNDPCP entity shall first check if it has a pending SN-DATA request. If there is data awaiting transmission, then the MS SNDPCP entity shall send an MLE-ACTIVITY request with sleep mode set to "stay alive", send to the SwMI a SN-RECONNECT PDU with the field "Data to Send" set to 1.

Where the MS supports advanced link roaming (see clause 28.3.4.4) and where the SNDPCP entity is aware that a partially transmitted TL-SDU is in the LLC buffers (i.e. one which has not yet been fully transmitted or one for which an acknowledgement has not yet been received from the peer entity), then the MS shall also set the field "Data to Send" set to 1.

It shall then stop the READY timer, start the STANDBY and RESPONSE\_WAIT timers and enter RESPONSE-WAITING. If there is no data awaiting transmission, then MS SNDPCP entity shall send to the SwMI a SN-RECONNECT PDU with the field "Data to Send" set to 0. It shall then stop the READY timer, start the STANDBY timer and enter STANDBY state.

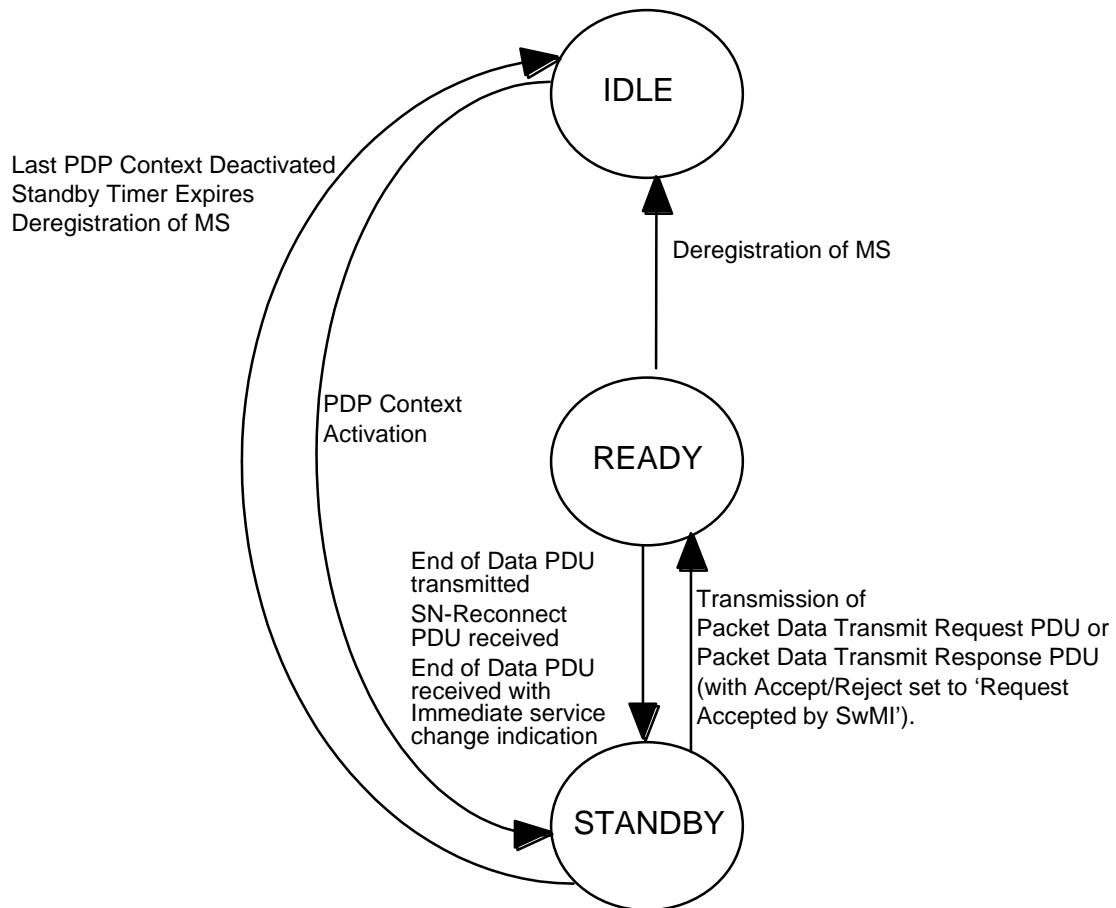
Where the READY timer expires, the MS SNDPCP entity shall enter STANDBY-Temporary Break state.

If the MNI values in the MLE-RESUME indication primitive do not match with the ones in the MLE-OPEN indication primitive, the MS knows that it has changed the network and it shall enter the IDLE state. The MS shall stop the READY timer and may attempt to reactivate the existing PDP contexts by sending SN-ACTIVATE PDP CONTEXT DEMAND PDUs to the SwMI after state transition, otherwise it shall deactivate all contexts locally. After successful PDP context activation the MS shall start the STANDBY timer and enter STANDBY state.

#### 28.2.5 State transitions and functions

The movement from one state to the next is dependent on the current state and the triggering event. Figures 184 and 185 show the state transition diagrams for the MS and SwMI SNDPCP entities respectively.





**Figure 185: Functional SMDCP State Transition Model for SwMI**

Tables 365 and 366 provide a summary of the triggers which shall result in a state transition, the actions which must be performed and the new state which is entered.

Table 365: MS State Transition Table

Current State	Event	Actions	New State
Any State	MLE-CLOSE ind received	Stop STANDBY, READY and RESPONSE_WAIT timers. Fail all pending SN-DATA req Delete all PDP contexts Go to CLOSED	CLOSED
CLOSED	MLE-OPEN ind received	Go to IDLE	IDLE
IDLE	MLE-BREAK ind received	Go to IDLE Temp Break	IDLE Temp Break
	First PDP Context Activation	Start STANDBY timer Go to STANDBY	STANDBY
IDLE-Temp Break	MLE-RESUME ind received	Go to IDLE	IDLE
STANDBY	Last PDP Context Deactivated	Stop STANDBY timer Go to IDLE	IDLE
	STANDBY timer expires	Delete all PDP contexts Go to IDLE	IDLE
	Receive SN-DATA TRANSMIT REQUEST PDU	Stop STANDBY timer Start READY timer Go to READY	READY
	Transmit SN-DATA TRANSMIT REQUEST PDU	Start RESPONSE_WAIT timer Send MLE-ACTIVITY "stay alive" Go to RESPONSE-WAITING	RESPONSE-WAITING
	MLE-BREAK ind received	Go to STANDBY Temp Break	STANDBY Temp Break
STANDBY-Temp Break	MLE-RESUME ind received	Go to STANDBY	STANDBY
	MLE-RESUME ind received and according to MNI values the MS has changed the network.	Stop STANDBY timer Delete all PDP contexts Go to IDLE	IDLE
	STANDBY timer expires	Delete all PDP contexts Go to IDLE Temp Break	IDLE Temp Break
RESPONSE-WAITING	Receive SN-DATA TRANSMIT RESPONSE PDU (Accept/Reject = 1)	Stop STANDBY timer Stop RESPONSE_WAIT timer Send MLE-ACTIVITY "sleep permitted" Start READY timer Go to READY	READY
	Receive SN-DATA TRANSMIT RESPONSE PDU (Accept/Reject = 0)	Stop RESPONSE_WAIT timer Send MLE-ACTIVITY "sleep permitted" Fail all pending SN-DATA req Go to STANDBY	STANDBY
	Receive SN-DATA TRANSMIT REQUEST PDU	Stop STANDBY timer Stop RESPONSE_WAIT timer Send MLE-ACTIVITY "sleep permitted" Start READY timer Go to READY	READY
	RESPONSE_WAIT timer expires	Fail all pending SN-DATA req Send MLE-ACTIVITY " sleep permitted " Go to STANDBY	STANDBY
	STANDBY timer expires	Stop RESPONSE_WAIT timer Send MLE-ACTIVITY " sleep permitted " Fail all pending SN-DATA req Delete all PDP contexts Go to IDLE	IDLE
	MLE-BREAK ind received	Stop RESPONSE_WAIT timer Fail all pending SN-DATA req Send MLE-ACTIVITY "sleep permitted" Go to STANDBY Temp Break	STANDBY Temp Break



Current State	Event	Actions	New State
READY	Receive SN-END OF DATA PDU	Stop READY timer Start STANDBY timer Go to STANDBY	STANDBY
	Number of SN-END OF DATA PDU retransmissions exceeded	Stop READY timer Start STANDBY timer Go to STANDBY	STANDBY
	Immediate service change indicated	Stop READY timer Start STANDBY timer Go to STANDBY	STANDBY
	MLE-BREAK ind received	Go to READY Temp Break	READY Temp Break
READY-Temp Break	MLE-RESUME ind received and there is data to send.	Transmit SN-RECONNECT PDU (Data to Send = 1) Send MLE-ACTIVITY "stay alive" Stop READY timer Start STANDBY timer Start RESPONSE_WAIT timer Go to RESPONSE-WAITING	RESPONSE-WAITING
	MLE-RESUME ind received and there is no data to send.	Transmit SN-RECONNECT PDU (Data to Send = 0) Stop READY timer Start STANDBY timer Go to STANDBY	STANDBY
	MLE-RESUME ind received and according to MNI values the MS has changed the network. PDP context activation after migration.	Stop READY timer Delete all PDP contexts Go to IDLE	IDLE
	READY timer expires	Go to STANDBY Temp Break	STANDBY Temp Break

Table 366: SwMI State Transition table

Current State	Event	Actions	New State
IDLE	First PDP Context Activation	Start STANDBY timer Go to STANDBY	STANDBY
STANDBY	Last PDP Context Deactivated	Stop STANDBY timer Go to IDLE	IDLE
	STANDBY timer expires	Delete all PDP contexts Go to IDLE	IDLE
	Deregistration of MS	Delete all PDP contexts Go to IDLE	IDLE
	Transmit SN-DATA TRANSMIT REQUEST PDU	Stop STANDBY timer Start READY timer Go to READY	READY
	Transmit SN-DATA TRANSMIT RESPONSE PDU (Accept/Reject = 1)	Stop STANDBY timer Start READY timer Go to READY	READY
READY	Transmit SN-END OF DATA PDU	Stop READY timer Start STANDBY timer Go to STANDBY	STANDBY
	Deregistration of MS	Stop READY timer Delete all PDP contexts Go to IDLE	IDLE
	SN-END OF DATA PDU received with an indication of immediate service change	Stop READY timer Start STANDBY timer Go to STANDBY	STANDBY
	SN-RECONNECT PDU received	Stop READY timer Start STANDBY timer Go to STANDBY	STANDBY

## 28.2.5a Other MLE primitives

This clause describes other MLE primitives at the LTPD-SAP, which do not cause any SNDCP state transition and are more or less separate from normal SNDCP state transition model.

On reception of an MLE-INFO indication primitive, which indicates that the subscriber class being broadcasted by the SwMI and the subscriber class of the MS do not match in the current cell, the MS SNDCP shall stop the communication with the peer entity totally. However, the SwMI should not offer packet data service to the MS, which subscriber class parameter does not match. This information is relevant also in other SNDCP states where the MS is seen as reachable in this case for TETRA Packet data.

On reception of an MLE-BUSY indication primitive, the MS SNDCP entity knows that an MM protocol exchange is in progress. Then the MS SNDCP shall stop the communication with the peer entity and cannot continue it until it receives an MLE-IDLE indication primitive.

On reception of an MLE-IDLE indication primitive, the MS SNDCP entity knows that an MM protocol exchange has completed and it may continue its normal function.

## 28.2.6 STANDBY, READY and RESPONSE\_WAIT timer functions

### 28.2.6.1 STANDBY timer function

The purpose of the STANDBY Timer is to work as a fallback timer to delete the PDP contexts when they remain unintentionally undeleted.

The STANDBY timer function maintains the STANDBY timer in the MS and SwMI. When the STANDBY timer expires, the MS and SwMI return to IDLE state (or for the MS only, where the previous state was STANDBY-Temporary Break, then the MS shall enter IDLE-Temporary Break), and the PDP contexts are deleted locally.

The duration of the STANDBY timer is the same in the MS and SwMI. Normally, the length of the STANDBY timer is defined by a default value. The SwMI, and only the SwMI, may change this value dynamically by transmitting a new value in the header part of a PDP context activation PDU (accept).

In the present document, the STANDBY timer shall not be set to 0. If the STANDBY timer is set to all 1s (binary), then the STANDBY timer function is deactivated (i.e., the timer no longer runs and the MS and SwMI remain in STANDBY state).

The STANDBY timer is reset and begins running in the MS in the following circumstances:

- on entering STANDBY state from IDLE state;
- on entering STANDBY state from RESPONSE-WAITING state after reception of a SN-DATA TRANSMIT RESPONSE PDU with Accept/Reject = 0;
- on entering STANDBY state from READY state after reception of a SN-END OF DATA PDU;
- on entering STANDBY state from READY-Temporary Break state after transmission of a SN-RECONNECT PDU with "Data to Send" = 0 ;
- on entering RESPONSE-WAITING state from READY-Temporary Break state after transmission of a SN-RECONNECT PDU with "Data to Send" = 1 .

The STANDBY timer is stopped in the MS in the following circumstances:

- On entering CLOSED state;
- On entering IDLE state from STANDBY state;
- On entering READY state from STANDBY state after reception of a SN-DATA TRANSMIT REQUEST PDU;
- On entering READY state from RESPONSE-WAITING state after reception of a SN-DATA TRANSMIT REQUEST PDU;

- On entering READY state from RESPONSE-WAITING state after reception of a SN-DATA TRANSMIT RESPONSE PDU with Accept/Reject = 1.

The STANDBY timer is reset and begins running in the SwMI in the following circumstances:

- on entering STANDBY state from IDLE state;
- after transmission of a SN-DATA TRANSMIT RESPONSE PDU with Accept/Reject = 0;
- on entering STANDBY state from READY state after transmission of a SN-END OF DATA PDU;
- on entering STANDBY state from READY state after reception of a SN-RECONNECT PDU.

The STANDBY timer is stopped in the SwMI in the following circumstances:

- on entering IDLE state from STANDBY state;
- on entering READY state from STANDBY state after transmission of a SN-DATA TRANSMIT REQUEST PDU;
- on entering READY state from STANDBY state after transmission of a SN-DATA TRANSMIT RESPONSE PDU with Accept/Reject = 1.

### 28.2.6.2 READY timer function

The READY timer function maintains the READY timer in the MS and SwMI. The READY timer may be defined for each MS separately. The READY timer controls with the help of other potential timers the time an MS and SwMI remains in READY state after either a SN-DATA, SN-UNITDATA, SN-DATA TRANSMIT REQUEST PDU (SwMI to MS) or SN-DATA TRANSMIT RESPONSE PDU (SwMI to MS) has been transmitted between the MS and SwMI. When the READY timer expires in the MS, the MS shall send SN-END OF DATA PDU to the SwMI and restart READY timer. The MS shall stop the READY timer, start the STANDBY timer and enter to the STANDBY state on receiving SN-END OF DATA PDU. When the READY timer expires in the SwMI, the SwMI shall send a SN-END OF DATA PDU to the MS and enter to the STANDBY state. The SwMI may also send a SN-END OF DATA PDU to the MS also due its own reasons.

NOTE 1: It is recommended that Packet Data CHannel (PDCH) releasing is done by the SwMI and the MS PDCH release is used as a fallback method. This means that the SwMI should set its own READY timer to a shorter value than the one sent to the MS in the SN- Activate PDP Context Accept PDU.

In the present document, the READY timer shall not be set to 0.

The READY timer is reset and begins running in the MS and SwMI in the following cases:

- every time a PDP datagram has been transmitted successfully (as indicated by reception of a MLE-REPORT from the MLE) or received by the MS or SwMI;
- when a SN-DATA TRANSMIT RESPONSE PDU with Accept/Reject = 1, is transmitted (SwMI only) or received (MS only);
- when a SN-DATA TRANSMIT REQUEST PDU is transmitted (SwMI only) or received (MS only);
- when an MLE-CONNECT confirm or an MLE-CONNECT indication primitive is received from the MLE; and
- when an MLE-RECONNECT confirm or an MLE-RECONNECT indication primitive is received from the MLE..

NOTE 2: In the case where a MS receives a group addressed SN-DATA TRANSMIT REQUEST the MS SMDCP entity does not start the READY timer when entering READY state. The READY timer is not activated when a MS enters READY state for reception of point to multipoint packet data.

NOTE 3: In the case of the SN-DATA TRANSMIT RESPONSE and SN-DATA TRANSMIT REQUEST PDUs, transmitted here means that it has been transmitted over the air interface. Acknowledgement from the peer entity is not required nor awaited.

### 28.2.6.3 RESPONSE\_WAIT Timer Function

The RESPONSE\_WAIT timer function maintains the RESPONSE\_WAIT timer in the MS. The duration of the RESPONSE\_WAIT timer is assigned by the SwMI at PDP context activation. The value received from the SwMI in the most recent PDP context activation shall apply to all contexts. The RESPONSE\_WAIT timer controls the time an MS shall await a response from the SwMI to a SN-DATA TRANSMIT REQUEST PDU and hence the time a MS remains in RESPONSE-WAITING state. If a response (in the form of a SN-DATA TRANSMIT RESPONSE) is received before the RESPONSE\_WAIT timer expires, then MS shall leave RESPONSE-WAITING state and stop the RESPONSE\_WAIT timer. If a response is not received before the RESPONSE\_WAIT timer expires, then MS shall go to STANDBY state.

The RESPONSE\_WAIT timer is reset and begins running in the MS when entering RESPONSE-WAITING state.

The RESPONSE\_WAIT timer is stopped in the MS when leaving RESPONSE-WAITING state.

## 28.3 SNDCP Procedures

### 28.3.1 Services provided by the protocol

SNDCP performs the following functions (see figures 186 and 187):

- PDP context activation and PDP context deactivation;
- Packet Data CHannel (PDCH) handling;
- multiplexing of N-PDUs from one or several higher protocol entities onto a single layer 2 connection;
- mapping of SN primitives received from the network layer into corresponding MLE-UNITDATA primitives to be passed to the MLE;
- management of the delivery sequence according to the PDU priority of SN-UNITDATA and SN-DATA primitives;
- compression and recovery of redundant protocol control information (e.g. TCP/IP header). Header compression is performed independently for each NSAPI;
- compression and recovery of redundant user data. Data compression is performed independently for each NSAPI.

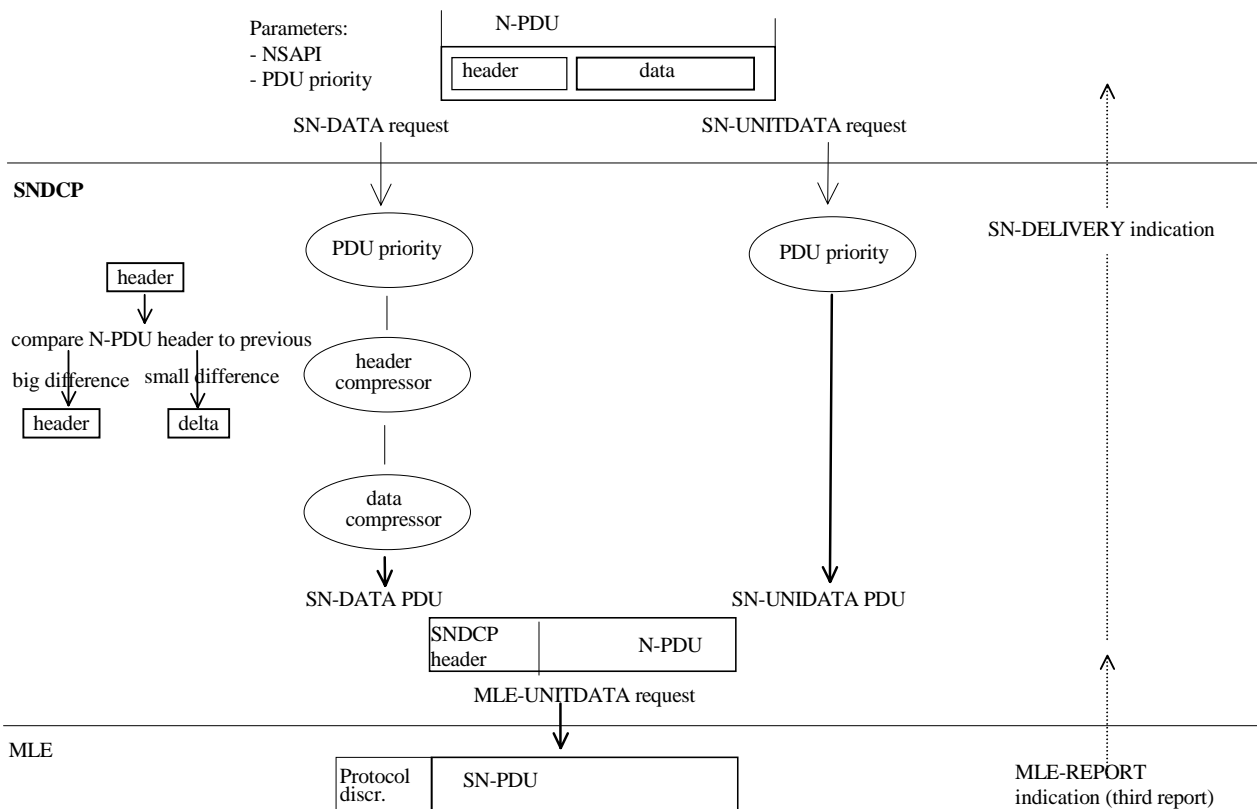


Figure 186: SNDCP model for transmitting end

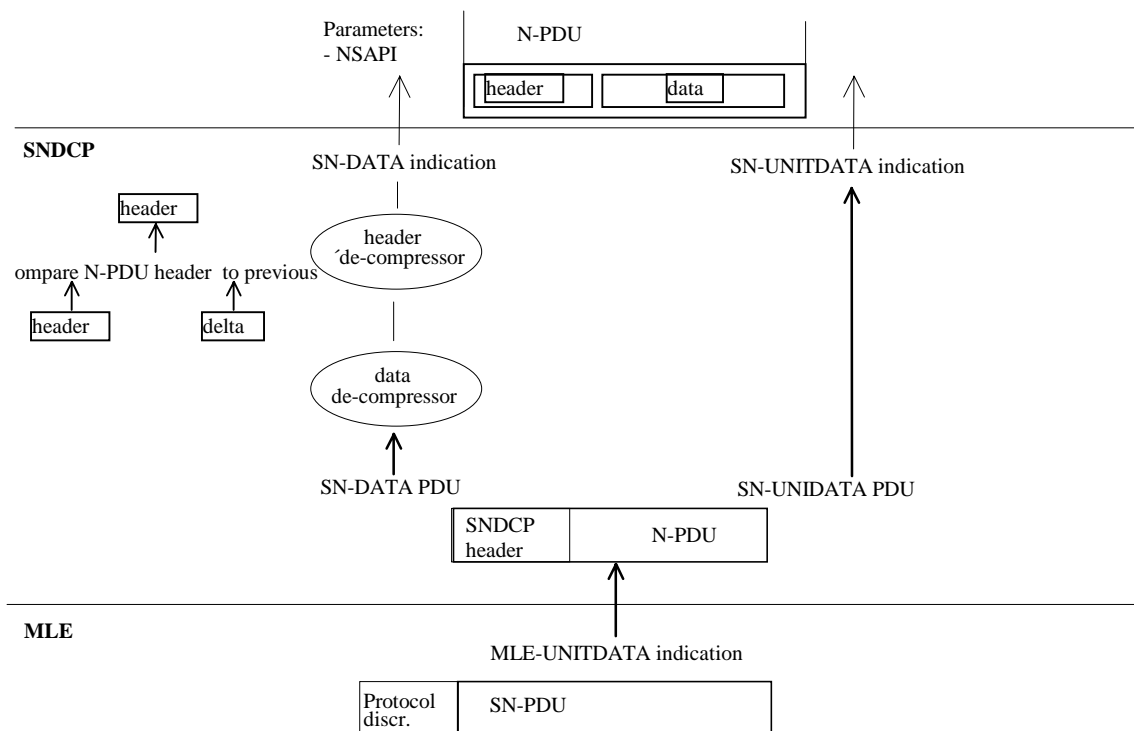


Figure 187: SNDCP model for receiver end

## 28.3.2 Underlying services assumed by the protocol

The following services are expected to be provided by the MLE through the LSND-SAP:

- acknowledged (MS -> SwMI and SwMI-> MS) and unacknowledged (SwMI -> MS) data transfer;
- point-to-point (MS -> SwMI and SwMI -> MS) and point-to-multipoint data transfer (SwMI -> MS);
- PDU priority based transfer of SN-PDUs (8 priority levels);
- in-order delivery of SN-PDUs per PDU priority (i.e. SN-PDUs with the same priority have to appear at the receiving end in the same order as transmitted between SNDCP entities). This is required only for acknowledged service;
- support for variable length SN-PDUs;
- indications about radio link condition (CLOSE, OPEN, BREAK);
- indications about LLC connection (establishment, re-connection, release);
- access to disconnect LLC connection.

## 28.3.3 Context activation and deactivation procedures

An MS in IDLE, STANDBY or READY state can initiate context activation functions to establish a virtual data channel i.e. PDP context between the MS and the SwMI. An MS in STANDBY state can initiate context deactivation functions.

Upon receiving an SN-ACTIVATE PDP CONTEXT DEMAND PDU, the SwMI shall initiate procedures to set up the PDP context.

Upon receiving a SN-DEACTIVATE PDP CONTEXT DEMAND PDU, the SwMI shall initiate procedures to delete the PDP context.

Upon receiving a SN-DEACTIVATE PDP CONTEXT DEMAND PDU, the MS shall initiate procedures to delete the PDP context.

A MS may only attempt to activate one PDP context at a time. Hence a MS after transmitting a SN-ACTIVATE PDP CONTEXT DEMAND PDU must await the occurrence of one of the following events, before sending a new SN-ACTIVATE PDP CONTEXT DEMAND PDU:

- reception of a SN-ACTIVATE PDP CONTEXT ACCEPT PDU;
- reception of a SN-ACTIVATE PDP CONTEXT REJECT PDU;
- expiration of the PDP\_ACTIVATE\_WAIT timer.

A MS may only have one PDP context deactivation request outstanding at a time. Hence a MS after transmitting a SN-DEACTIVATE PDP CONTEXT DEMAND PDU must await the occurrence of one of the following events, before sending a new SN-DEACTIVATE PDP CONTEXT DEMAND PDU:

- reception of a SN-DEACTIVATE PDP CONTEXT ACCEPT PDU;
- expiration of the PDP\_DEACTIVATE\_WAIT timer.

### 28.3.3.1 Internet Protocol addressing support

#### 28.3.3.1.1 IPv4 - Static and dynamic IP addresses

A TETRA system can be viewed as a single or multiple IP subnets. A TE which is attached to a MT on a TETRA network, can be viewed as a host on an IP subnet.

In order for IP packets from an external IP network, to reach a data TE which is attached to a MT on a TETRA network, it is necessary for the destination address used in the IP packets to be topologically correct i.e. packets, using standard internet routing procedures, can be forwarded to the TETRA network. The forwarding of packets within the TETRA network is outside of the scope of the present document.

IP addresses can be allocated to an MS in two different ways:

- an IP address is assigned permanently to the MS. The IP address shall be sent to the SwMI when activating PDP context;
- the SwMI assigns a dynamic IP address to the MS when PDP context is activated.

It is the operator that defines in the subscription whether a dynamic IP address can be used.

When dynamic addressing is used, it is the responsibility of the SwMI to allocate and release the dynamic IP address.

#### 28.3.3.1.2 Mobile IPv4

Mobile IP allows nodes to move from one IP subnet to another without changing their IP address. A brief overview of Mobile IP is given below so as to help illustrate the addressing concept, however the reader is referred to IETF RFC 3220 [48] for a more complete description of the protocol.

In the description below, the following definitions apply:

- **Mobile Node:** An IP host or router that changes its point of attachment to the internet from one subnet to another;
- **Home address:** Internet protocol address, that is assigned to a Mobile Node for an extended period of time. This address is used by all other nodes when attempting to send datagrams to the Mobile Node. This address remains constant irrespective of the Mobile Nodes point of attachment to the internet;
- **Home network:** A network, having a network prefix matching that of the Mobile Node's home address. Standard IP routing mechanisms ensure that datagrams destined for the Mobile Node's home address are routed via the Mobile Node's home network;
- **Foreign network:** Any network, other than the Mobile Node's home network, i.e. a network which has a network prefix different to that of the Mobile Node's home IP address;
- **Visited Network:** A foreign network to which the Mobile Node is currently connected;
- **Home Agent:** A router on a Mobile Node's home network which tunnels datagrams for delivery to the Mobile Node when it is away from its home network. The Home Agent has similar functionality to the Home Location Register (HLR) in GSM;
- **Foreign Agent:** A router on the Mobile Node's visited network which detunnels and delivers datagrams to the Mobile Node, that were tunneled by the Home Agent;
- **Care-of Address:** The termination point of a tunnel towards a Mobile Node, for datagrams forwarded to the Mobile Node while it is away from its home network. The protocol can use two different types of care-of address: a "foreign agent care-of address" is an address of a foreign agent with which the mobile node is registered, and a "co-located care-of address" is an externally obtained local address which the mobile node has associated with one of its own network interfaces.

A Mobile Node is given a long term IP address on a home network. This IP address is administered in the same way as a "permanent" IP address is provided to a stationary host. When the Mobile Node detects that it is located on its home network, it operates without mobility services.

When a Mobile Node detects that it has moved to a foreign network, it obtains a care-of address on the foreign network. The mobile node then registers its new care-of address with its Home Agent.

Datagrams sent to the Mobile Node's home address are intercepted by its Home Agent, tunnelled by the Home Agent to the Mobile Node's care-of address, received at the tunnel endpoint (typically the foreign agent), and finally delivered to the mobile node.

In the reverse direction, datagrams sent by the mobile node are generally delivered to their destination using standard IP routing mechanisms, not necessarily passing through the home agent.

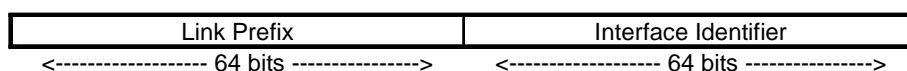
The TETRA packet data specification extends a TETRA network to act as one or more IP subnets. A TETRA network may offer Mobile IP services by including Home Agent and/or Foreign Agent functionality. The TETRA packet data specification provides a mechanism by which a Mobile Node may use Mobile IP services where they are available.

As an example, where a TETRA SwMI includes Mobile IP Foreign Agent functionality, a Mobile Node may perform Mobile IP Registration as described in IETF RFC 3220 [48] with its Home Agent (which may be located on a fixed IP subnet) via the SwMI based Foreign Agent. This Foreign Agent shall then act as the tunnel end point for those IP datagrams forwarded by the Home Agent. The Mobile Node may learn the Foreign Agent Care of Address through the PDP Context Activation procedure.

In TETRA Packet data, a MS shall indicate if it wishes to avail of Mobile IP services in the SN-ACTIVATE PDP CONTEXT DEMAND PDU by setting "Address Type Identifier in Demand" to "Mobile IPv4 Foreign Agent Care-of Address" or "Mobile IPv4 Co-located Care-of Address". A SwMI which offers support for Mobile IP services may respond with a "Mobile IPv4 Care-of Address" plus further information within the informational element "SwMI Mobile IPv4 Information" of the SN-ACTIVATE PDP CONTEXT ACCEPT PDU.

### 28.3.3.1.3 IPv6

IPv6 will support two methods for a host to obtain a global IPv6 address. Stateful address autoconfiguration shall enable a host to be dynamically allocated an IP address through the use of a protocol such as Dynamic Host Configuration Protocol (DHCPv6). This will operate in a similar way to dynamic address allocation in IPv4. Stateless address autoconfiguration enables a host to generate its own IP address through information broadcast on the network where it is camped. The IPv6 address is 128 bits compared to 32 bits in IPv4. The address is broken into two parts, the Link Prefix and the Interface Identifier as shown in figure 188.



**Figure 188: Ipv6 address**

In the case of both address autoconfiguration methods, the IPv6 node must first generate a link local IPv6 address. A link-local IPv6 address may only be used on the link or subnet to which the node is connected. To generate a link local address, an IPv6 node combines an Interface-Identifier with the Link Prefix which has been reserved for link local addresses. The IPv6 node will then use this link local IPv6 address to obtain a global IPv6 address. Typically this will involve sending a Router Solicitation and receiving a Router Advertisement.

In TETRA Packet data, a MS indicates in the SN-ACTIVATE PDP CONTEXT DEMAND PDU whether it wishes to use IPv6 services by setting "Address Type Identifier in Demand" appropriately.

Where the SwMI indicates in a SN-ACTIVATE PDP CONTEXT ACCEPT PDU that IPv6 is supported, the MS may then use a link local IPv6 address to perform stateful or stateless address autoconfiguration.

It is recommended that when generating a link local IPv6 address, the MS shall use its ITSI as the 48 least significant bits of the Interface Identifier thus ensuring that the Interface Identifier is unique on the link or subnet. A further requirement for Interface Identifier, is for the 6th most significant bit to be set to zero. All other bits of the Interface Identifier may be set to zero or may be used to support multiple link local addresses per ITSI.

This version of the packet data specification does not specify how IPv6 service is provided by a SwMI or the actions which a MS must take in order to obtain a global IPv6 address. Where a SwMI sends a SN-ACTIVATE PDP CONTEXT ACCEPT PDU indicating that it supports IPv6 services, it is recommended that the SwMI then prepares to receive a Router Solicitation and respond with a Router Advertisement.



### 28.3.3.2 NSAPI usage

The set of protocol entities above SNDCP uses the same SNDCP entity, which then performs multiplexing of data coming from different sources to be sent across a single LLC connection. Sharing a single LLC connection requires that different addresses can be identified. The NSAPI field of four bits is used for this purpose, defining the end user PDP type and PDP address pair that the MS is using. Following values are reserved for special use:

- 0 is reserved;
- 15 is reserved.

NOTE 1: The user application should start from NSAPI value 1 when allocating the first PDP context.

Other values are allocated dynamically. The allocation of the dynamic NSAPIs can be e.g. following:

- IPv4: 133.12.75.111 => NSAPI = 2
- IPv4: 133.12.75.222 => NSAPI = 3

NOTE 2: NSAPI may be used also for routing between MT and TE, e.g. NSAPI = 2 is activated by the TE2 and NSAPI = 3 is activated by the MT (actually MT0 to be exact i.e. the MS may act as MT0 and MT2 at the same time). This kind of routing is, however, outside the scope of the present document.

Since the adaptation of different higher layer protocol to SNDCP is implementation dependent, it is not defined in the present document.

### 28.3.3.3 SNDCP network endpoint identifier

Within the SwMI, there may be a requirement for multiple SNDCP entities in order to provide load balancing or to provide packet data service for different geographical regions. In order to support the existence of multiple such SNDCP entities within the SwMI, a SNDCP Network Endpoint Identifier (SNEI) may be assigned to each MS at PDP Context Activation. The SNEI field shall only be present in uplink communication when the SwMI has assigned a SNEI value to the MS during context activation. Where the MS has been assigned a SNEI value during PDP context activation, then there are four occasions where the MS shall include the SNEI as part of uplink communication:

1. When in READY state and after performing a cell change, the MS SNDCP entity shall include the SNEI as part of the Reconnect message (see clause 8.4.2 c);
2. When requesting permission to transmit data the MS SNDCP entity shall include the SNEI;
3. When responding to a page from the SwMI, the MS SNDCP entity shall include the SNEI;
4. When deactivating a PDP context, the MS SNDCP entity shall include the SNEI.

The SwMI may assign a new SNEI to a MS in any of the following circumstances:

1. When activating a new PDP context;
2. When responding to a request from a MS to transmit data;
3. When paging a MS.

On reception of a new SNEI value, the MS SNDCP entity should store this value for later use. The value of SNEI which the MS shall send to the SwMI during uplink communication shall be the most recently received SNEI. The SwMI shall only assign one SNEI per ITSI. The most recently received SNEI shall apply to all PDP contexts for a given ITSI.

The usage of the SNEI within the SwMI is outside the scope of the present document.

### 28.3.3.4 Definition of Packet data MS Types

The following clauses 28.3.3.4.1 to 28.3.3.4.4 describe the service interactions between circuit mode, messaging and packet data services as defined by the value of the Packet data MS Type element. The types have meaning only in the context of TETRA Packet data. It is used by the MS to indicate to the SwMI its service interaction capabilities between packet data and individual circuit mode speech and data calls. The Packet data MS Type is sent to the SwMI when activating PDP context. If the Packet data MS Type is changed after the first PDP context activation, then the SwMI shall use the Packet data MS Type value, as received in the latest PDP activation.

NOTE 1: If the SwMI rejects a PDP context activation with the Activation reject cause set as "Packet Data MS type not supported" the MS may retry the PDP context activation with a lower Packet Data MS type e.g. if the SwMI rejects a Packet Data MS type of A the MS may try to activate a context as a Packet Data MS type of B, C or D. How the MS determines which Packet Data MS type to choose following a PDP context activation rejection is outside the scope of the present document.

The SwMI may use the Packet data MS type value to assist in optimising air interface signalling when offering packet data services to an MS. For example the SwMI may choose not to offer (because the MS will probably not accept):

- TETRA Packet data to type D and C MS which is engaged in a circuit mode speech/data;
- Circuit mode speech/data to type D and C MS which is engaged in TETRA Packet data.

NOTE 2: If the MS is offered a circuit mode service, it may choose to ignore, reject or accept the service. The criteria for the MS to ignore, reject or accept the service are outside the scope of the present document.

In addition SwMI should be aware that type B MS shall abandon TETRA Packet data temporarily if it accepts or initiates circuit mode speech/data and vice versa. Type A MS may preserve both services parallel.

NOTE 3: SN-NSAPI ALLOC request primitive does not contain MS TETRA Packet data Type as a parameter. This is because the type may be constrained by the capabilities of the MS.

NOTE 4: An MS should always be capable of making an emergency call set-up irrespective of the packet data MS Type and packet data state.

NOTE 5: How the SwMI determines the circuit mode status of an MS is outside the scope of the present document.

NOTE 6: The SwMI can only optimise the air interface signalling when interacting with individual calls. Interaction with group calls and Supplementary Services is outside the scope of the present document.

The different types for TETRA Packet data MSs and their capabilities to handle other services in addition to TETRA Packet data are summarised in table 366A.

**Table 366A: Packet data MS types and other services**

Service	Type A	Type B	Type C	Type D
Circuit mode speech/data conducted in READY state	X			
Circuit mode speech/data set-up in READY state	X	X		
SDS in READY state	X	X	X	
Circuit mode speech/data conducted in STANDBY state	X	X	X	X
TETRA Packet Data	X	X	X	X

#### 28.3.3.4.1 Type A - Parallel

All services (SDS, Circuit mode speech/data) may be conducted parallel with TETRA Packet data. MS has the capability to receive/send both circuit mode speech/data and TETRA Packet data at the same time. This means that circuit mode speech/data may be set-up, accepted and conducted while the MS is in READY state. SDS may be conducted while the MS is in READY state.

NOTE: This MS can only support concurrent Packet data and circuit mode if the appropriate resources matching the "Class of MS" (refer to clause 16.10.5) can be allocated by the SwMI.

### 28.3.3.4.2 Type B - Alternating

Other services (SDS, Circuit mode speech/data) may be conducted alternating with TETRA Packet data, i.e. if MS is engaged in TETRA Packet data it may accept circuit mode speech/data and vice versa but only one service (TETRA Packet data or circuit mode speech/data) can be active at any time. SDS can be conducted parallel both with TETRA Packet data and circuit mode speech/data. This means that circuit mode speech/data may be set-up but not conducted while the MS is in READY state. Circuit mode speech/data may be only conducted in STANDBY state.

### 28.3.3.4.3 Type C - IP single mode

The MS is engaged to one service at a time; if MS is engaged in TETRA Packet data it does not accept circuit mode speech/data and vice versa:

1. While the MS is in the READY state i.e. engaged in TETRA Packet Data, no circuit mode speech/data calls may be set-up, accepted or conducted. However, SDS may be conducted while the MS is in the READY state.
2. While the MS has an ongoing circuit mode speech/data call or is in the call set-up phase, TETRA Packet data is not allowed (accepted or initiated). This means that circuit mode speech/data may be set-up, accepted or conducted while the MS is in STANDBY state. SDS may also be conducted while the MS is in the STANDBY state.

NOTE: Circuit mode calls in the STANDBY state are only permitted if allowed by the "Class of MS" (refer to clause 16.10.5).

### 28.3.3.4.4 Type D - Restricted IP single mode

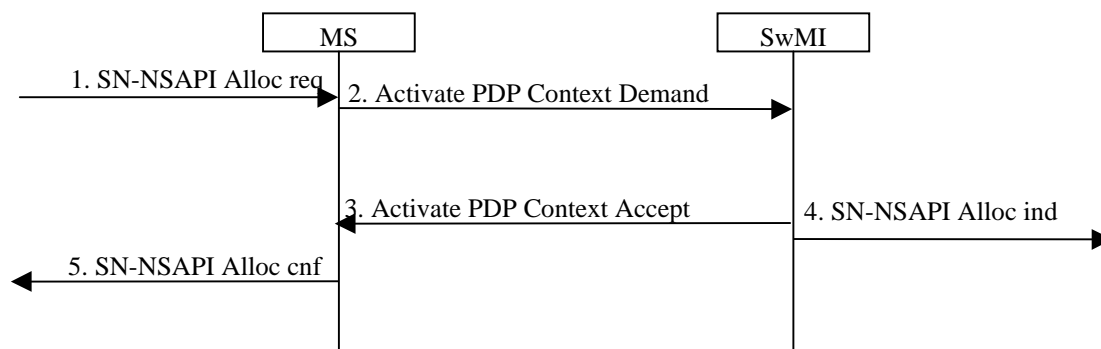
The MS is engaged to one service at a time; if MS is engaged in TETRA Packet data it does not accept circuit mode speech/data and does not support SDS and vice versa:

1. While the MS is in the READY state i.e. engaged in TETRA Packet Data, no circuit mode speech/data may calls be set-up, accepted or conducted. SDS should not be conducted while the MS is in READY state.
2. While the MS has an ongoing circuit mode speech/data call or is in the call set-up phase, TETRA Packet data is not allowed (accepted or initiated). This means that circuit mode speech/data may be set-up, accepted or conducted while the MS is in STANDBY state. SDS may also be conducted while the MS is in the STANDBY state.

### 28.3.3.5 PDP Context Activation Procedure

Successful PDP Context Activation procedure is illustrated in the figure 189. Each numbered step is explained in the following list.

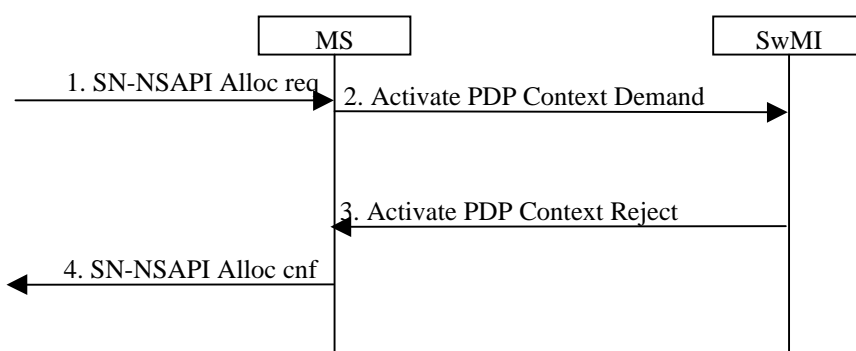
NOTE: In figures 189 to 192 the PDU names are presented without an "SN-" preamble.



**Figure 189: PDP Context activation procedure - activation accepted**

1. The SN-SAP user triggers PDP context activation by issuing SN-NSAPI alloc request.
2. The MS sends an SN-ACTIVATE PDP CONTEXT DEMAND PDU to the SwMI. The MS indicates the form of IP address it wishes to use in the element "Address Type Identifier in Demand". The MS shall start PDP\_ACTIVATE\_WAIT timer.
3. SwMI inserts the NSAPIs in its PDP Contexts. The SwMI returns an SN-ACTIVATE PDP CONTEXT ACCEPT PDU to the MS . The SwMI is now able to route PDP PDUs to and from MS. The MS shall stop PDP\_ACTIVATE\_WAIT timer.
4. The SwMI SN-SAP user is informed about PDP context activation by the SwMI SMDCP issuing SN-NSAPI Alloc indication
5. The MS SN-SAP user is informed about successful PDP context activation by the MS SMDCP issuing SN-NSAPI Alloc confirm.

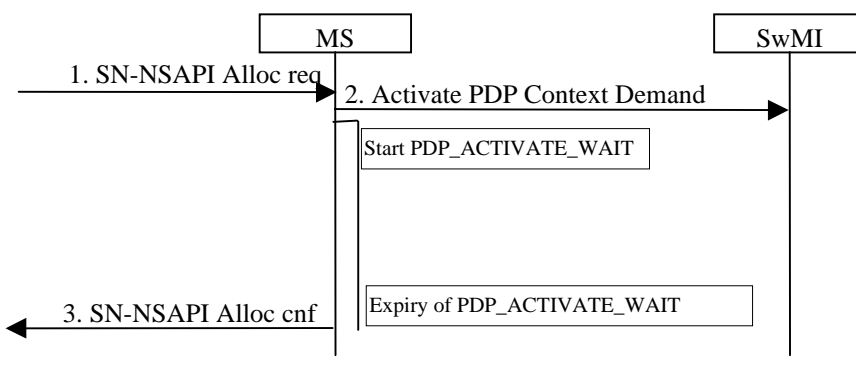
Unsuccessful PDP Context Activation procedure due to SwMI rejection is illustrated in the figure 190. Each numbered step is explained in the following list.



**Figure 190: PDP context activation procedure - activation rejected**

1. The SN-SAP user triggers PDP context activation by issuing SN-NSAPI alloc request.
2. The MS sends an SN-ACTIVATE PDP CONTEXT DEMAND PDU to the SwMI. The MS shall start PDP\_ACTIVATE\_WAIT timer.
3. SwMI rejects activation by returning a SN-ACTIVATE PDP CONTEXT REJECT PDU to the MS. The MS shall stop PDP\_ACTIVATE\_WAIT timer.
4. The MS SN-SAP user is informed about unsuccessful PDP context activation by the MS SMDCP issuing SN-NSAPI Alloc confirm.

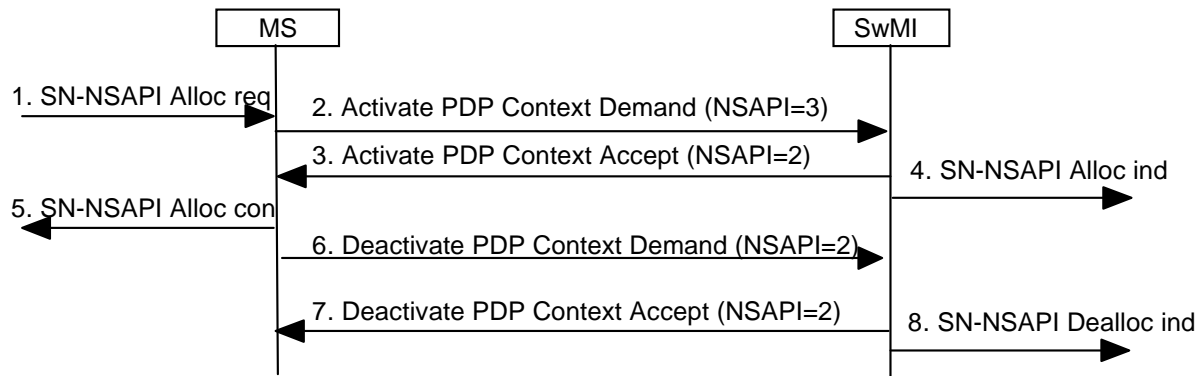
Unsuccessful PDP Context Activation procedure due to expiry of PDP\_ACTIVATE\_WAIT timer is illustrated in the figure 191. Each numbered step is explained in the following list.



**Figure 191: PDP context activation procedure - no response to activation**

1. The SN-SAP user triggers PDP context activation by issuing SN-NSAPI alloc request.
2. The MS sends an SN-ACTIVATE PDP CONTEXT DEMAND PDU to the SwMI. The MS shall start PDP\_ACTIVATE\_WAIT timer.
3. Timer PDP\_ACTIVATE\_WAIT timer expires. The MS SN-SAP user is informed about unsuccessful PDP context activation by the MS SNDSCP issuing SN-NSAPI Alloc confirm.

Unsuccessful PDP Context Activation procedure due to wrong NSAPI in the SwMI's response is illustrated in the figure 192. Each numbered step is explained in the following list.



**Figure 192: PDP context activation procedure - wrong NSAPI**

1. The SN-SAP user triggers PDP context activation by issuing SN-NSAPI alloc request.
2. The MS sends an SN-ACTIVATE PDP CONTEXT DEMAND PDU to the SwMI. The MS shall start PDP\_ACTIVATE\_WAIT timer.
3. SwMI inserts the NSAPIs in its PDP Contexts. The SwMI returns an SN-ACTIVATE PDP CONTEXT ACCEPT PDU to the MS. The MS shall stop the PDP\_ACTIVATE\_WAIT timer.
4. The SwMI SN-SAP user is informed about PDP context activation by the SwMI SNDSCP issuing SN-NSAPI Alloc indication.
5. The NSAPI in the Demand and Accept differ, and hence the MS SN-SAP user is informed about the failed PDP context activation by the MS SNDSCP issuing SN-NSAPI Alloc confirm.
6. The MS deactivates the NSAPI issued by the SwMI by sending a SN-DEACTIVATE PDP CONTEXT DEMAND PDU to the SwMI. The MS shall start the PDP\_DEACTIVATE\_WAIT timer.
7. The SwMI shall respond by sending a SN-DEACTIVATE PDP CONTEXT ACCEPT PDU to the MS. On reception of the SN-DEACTIVATE PDP CONTEXT ACCEPT PDU, the MS shall stop the PDP\_DEACTIVATE\_WAIT timer.
8. The SwMI SN-SAP user is informed about PDP context deactivation by the SwMI SNDSCP issuing SN-NSAPI Dealloc indication.

If the PDP context activation procedure fails, then the MS SNDSCP service user may attempt another activation to the same PDP Address up to a maximum number RETRY\_ACTIVATION of attempts.

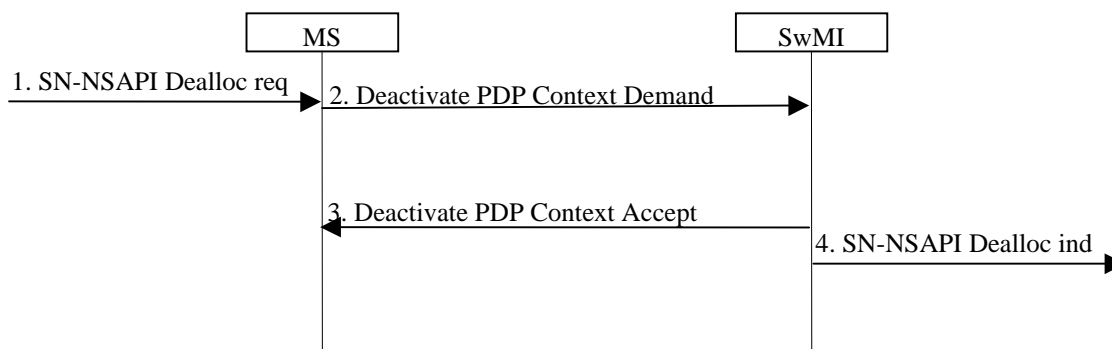
### 28.3.3.6 PDP context deactivation procedure

Either a MS or the SwMI may initiate the deactivation procedure.

#### 28.3.3.6.1 MS originated PDP context deactivation procedure

MS originated PDP Context Deactivation procedure is illustrated in the figure 193. Each numbered step is explained in the following list.

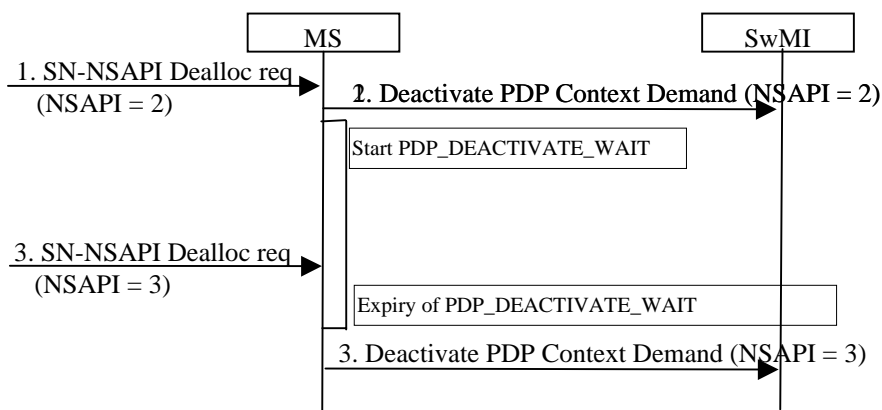
NOTE: In the figures 193 to 195 the PDU names are presented without an "SN-" preamble.



**Figure 193: PDP context deactivation procedure**

1. The SN-SAP user triggers PDP context deactivation by issuing SN-NSAPI dealloc request.
2. The MS sends a SN-DEACTIVATE PDP CONTEXT DEMAND PDU to the SwMI. The MS shall start PDP\_DEACTIVATE\_WAIT timer.
3. The SwMI returns a SN-DEACTIVATE PDP CONTEXT ACCEPT PDU to the MS. The MS shall stop PDP\_DEACTIVATE\_WAIT timer.
4. The SwMI SN-SAP user is informed about PDP context deactivation by the SwMI SNDSCP issuing SN-NSAPI DEALLOC indication.

MS originated PDP Context Deactivation unsuccessful procedure due to expiry of PDP\_DEACTIVATE\_WAIT timer is illustrated in the figure 194. Each numbered step is explained in the following list.



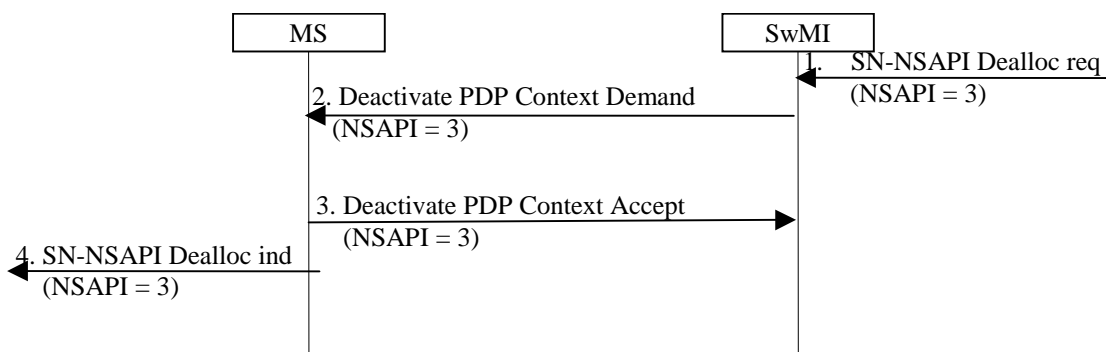
**Figure 194: PDP context deactivation procedure - no response to deactivation**

1. The SN-SAP user triggers PDP context deactivation by issuing SN-NSAPI dealloc request (NSAPI = 2 in this scenario).
2. The MS sends a SN-DEACTIVATE PDP CONTEXT DEMAND PDU (NSAPI = 2 in this scenario) message to the SwMI. The MS shall start PDP\_DEACTIVATE\_WAIT timer.
3. The SN-SAP user triggers PDP context deactivation by issuing SN-NSAPI dealloc request (NSAPI = 3 in this scenario).
4. Timer PDP\_DEACTIVATE\_WAIT timer expires. The MS shall not retry de-activation procedure for that NSAPI= 2 . The PDP context is deactivated locally.
5. The MS sends a Deactivate PDP Context Demand (NSAPI = 3 in this scenario) message to the SwMI. The MS shall start PDP\_DEACTIVATE\_WAIT timer.

The MS may use Deactivation type parameter value "Deactivation of all NSAPIs" when sending the SN-DEACTIVATE PDP CONTEXT DEMAND PDU. Should this happen the MS shall deactivate all its active PDP Contexts locally. The SwMI shall respond to the Demand by sending a SN-DEACTIVATE PDP CONTEXT ACCEPT PDU having Deactivation type parameter value "Deactivation of all NSAPIs" and deactivate all NSAPIs for that MS.

### 28.3.3.6.2 SwMI originated context deactivation procedure

SwMI originated PDP Context Deactivation procedure is illustrated in the figure 195. Each numbered step is explained in the following list.



**Figure 195: SwMI originated PDP context deactivation procedure**

1. The SN-SAP user triggers PDP context deactivation by issuing SN-NSAPI dealloc request (NSAPI = 3 in this scenario).
2. The SwMI sends a SN-DEACTIVATE PDP CONTEXT DEMAND PDU to the MS.
3. The MS sends a SN-DEACTIVATE PDP CONTEXT ACCEPT PDU to the SwMI.
4. The MS SN-SAP user is informed about PDP context deactivation by the MS SMDCP issuing SN-NSAPI DEALLOC indication.

In a case of failed PDP Context deactivation the SwMI may retry deactivation.

The SwMI may use Deactivation type parameter value "Deactivation of all NSAPIs" when sending the SN-DEACTIVATE PDP CONTEXT DEMAND PDU. Should this happen, the MS shall respond to the demand by sending a SN-DEACTIVATE PDP CONTEXT ACCEPT PDU having Deactivation type parameter value "Deactivation of all NSAPIs" and deactivate all NSAPIs locally.

## 28.3.4 Packet Data Channel (PDCH) handling procedures

The control channel procedures specified in the present document apply for TETRA packet data. The control channel used for TETRA packet data SN-PDU transfer is called the Packet Data Channel (PDCH). The SwMI may add channel allocation to SN-DATA TRANSMIT REQUEST PDU (Data from SwMI to MS). The SwMI may add channel allocation to SN-DATA TRANSMIT RESPONSE PDU (data from MS to SwMI) if MSs request to transmit is accepted by the SwMI.

The channel is released by the SwMI by issuing SN-END OF DATA PDU when SwMI's READY timer expires. Where the MS was directed to the PDCH using a channel allocation, then the SN-END OF DATA PDU shall include channel allocation to common control channel. If the READY timer expires in the MS, then the MS shall issue SN-END OF DATA PDU and await a corresponding SN-END OF DATA PDU from the SwMI.

NOTE 1: The case where the READY timer expires in the MS prior to reception of a SN-END OF DATA PDU should be viewed as an exceptional case. To ensure the MS receives a SN-END OF DATA PDU from the SwMI before its READY timer expires, the SwMI should set its own READY timer to a shorter value than the one sent to the MS in the SN-ACTIVATE PDP CONTEXT ACCEPT PDU.

NOTE 2: The packet channel is defined from a single MS point of view (except when the SwMI uses multicast address). Thus here the releasing the PDCH means releasing the channel for a single MS. In the same control channel there may be also more than one MS at the same time.

NOTE 3: The MS may choose to adjust its value of T.208 against READY timer on a PDCH to ensure that the use of SN-END OF DATA will be the normal way of leaving a PDCH.

### 28.3.4.1 Logical link handling

The table 367 defines the division between basic link and advanced link based on SN-PDU type.

**Table 367: Logical link usage by SN-PDUs**

SN-PDU	Basic link	Advanced link
SN-ACTIVATE PDP CONTEXT DEMAND	x	
SN-DEACTIVATE PDP CONTEXT DEMAND	x	
SN-ACTIVATE PDP CONTEXT ACCEPT	x	
SN-ACTIVATE PDP CONTEXT REJECT	x	
SN-DEACTIVATE PDP CONTEXT ACCEPT	x	
SN-UNITDATA		x
SN-DATA		x
SN-DATA TRANSMIT REQUEST	x	
SN-DATA TRANSMIT RESPONSE	x	
SN-NOT SUPPORTED	x	
SN-RECONNECT	x	
SN-PAGE REQUEST	x	
SN-PAGE RESPONSE	x	
SN-END OF DATA	x	

The basic links unacknowledged and acknowledged services are used by the MS and SwMI according to table 368.

**Table 368: Usage of basic link unacknowledged and acknowledged services**

SN-PDU	Unacknowledged	Acknowledged
SN-ACTIVATE PDP CONTEXT DEMAND		x
SN-DEACTIVATE PDP CONTEXT DEMAND		x
SN-ACTIVATE PDP CONTEXT ACCEPT		x
SN-ACTIVATE PDP CONTEXT REJECT		x
SN-DEACTIVATE PDP CONTEXT ACCEPT		x
SN-DATA TRANSMIT REQUEST	x (see note 1)	x (see note 1)
SN-DATA TRANSMIT RESPONSE	x	
SN-NOT SUPPORTED	x (see note 1)	x (see note 1)
SN-RECONNECT		x
SN-PAGE REQUEST	x (see note 2)	x (see note 2)
SN-PAGE RESPONSE		x
SN-END OF DATA	x (see note 1)	x (see note 1)
NOTE 1: The SwMI may use unacknowledged service or acknowledged response service and the MS shall use acknowledged service.		
NOTE 2: The SwMI may use either acknowledged or unacknowledged basic link service.		

The lower layer service selection is informed in the protocol model to the lower layers in the corresponding MLE service request primitive as the "layer 2 service" parameter.

### 28.3.4.2 Logical link setup

The MS shall be the active part in establishing the advanced link. There is only one advanced link used by the SMDCP per MS for acknowledged service. The MS shall not establish an advanced link for packet data if there are no PDP contexts active. Furthermore the SMDCP entity tracks whether the underlying advanced link is established or not.

The advanced link is established on the PDCH under the control of SMDCP. Once established, the advanced link stays established even when the MS resides on the MCCH but still the MS SMDCP must not use the advanced link without requesting the SwMI for permission.

NOTE: The MS may be involved in circuit mode speech/data in between accessing a PDCH. Then the advanced link remains established.



There are four scenarios listed below, where a MS may establish or reset the advanced link.

a) Inbound or outbound data pending - no active advanced link

A MS shall establish an advanced link, if there is not already an active advanced link and the MS has data to send or is notified by the SwMI that there is outbound data pending. This scenario is the typical scenario where a MS, after successfully activating a PDP context, wishes to send data. An example of the establishment of an advanced link in this scenario is presented in figures 196 to 199.

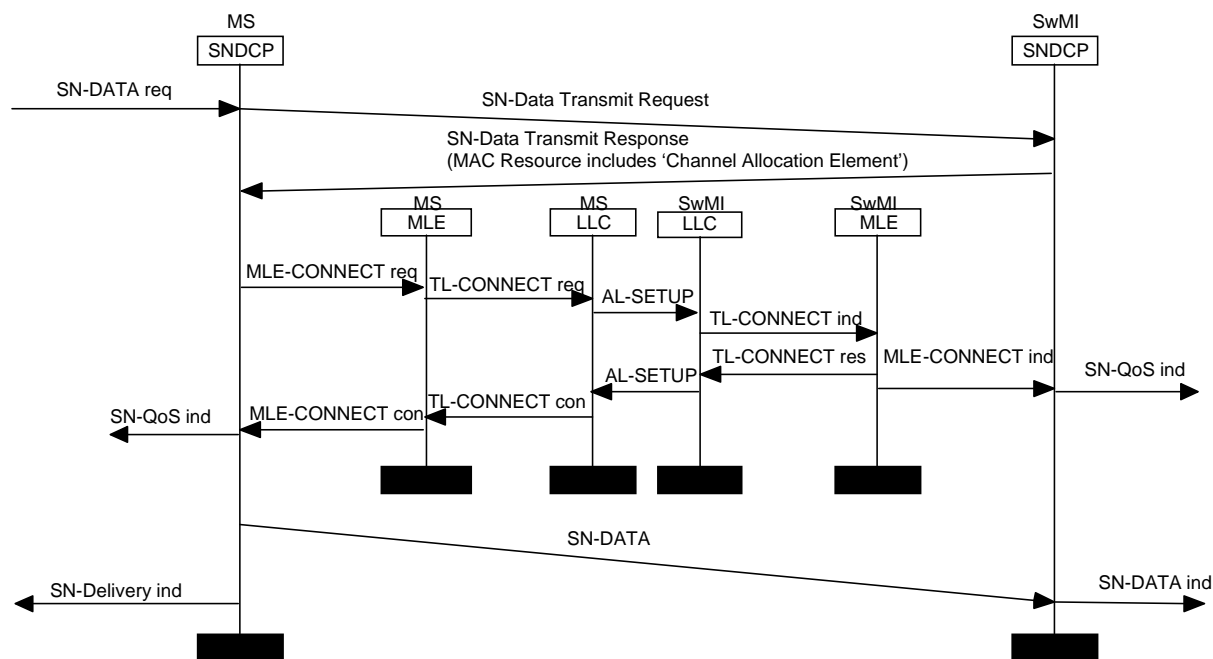
NOTE 1: The examples described below assume a channel allocation is required to direct a MS from its current channel to the PDCH. There may however be occasions where the SwMI decides to allow packet data transfer on a common control channel and therefore a channel allocation may not be required.

NOTE 2: The examples described below shows the MLE as the entity in the SwMI negotiating the establishment of the advanced link. This is due to there being no information contained within the AL-SETUP PDUs to indicate the layer 3 entity in the MS (e.g. SNDTCP, SDS, SS etc) which initiated the advanced link establishment, thus the SwMI MLE entity would be expected to negotiate on behalf of all SwMI layer 3 entities. The present document does not define how the establishment of the advanced link is negotiated within the SwMI.

In figure 196 the establishment of the advanced link is initiated by the arrival at the MS SNDTCP entity of a SN-DATA request primitive. While on a common control channel (MCCH or SCCH), the MS will send a SN-DATA TRANSMIT REQUEST PDU on the uplink using the acknowledged basic link service. The SwMI will respond by sending a SN-DATA TRANSMIT RESPONSE PDU to the MS. The MAC-RESOURCE which contains this PDU shall include a "Channel Allocation" element. As no advanced link exists, the SwMI shall direct the MS either to a single slot PDCH or to a multislot PDCH if enhanced service was indicated in "Resource request" element in the SN-DATA TRANSMIT REQUEST PDU.

Once on the PDCH, the MS shall establish an advanced link. This is achieved through the sending of a MLE-CONNECT request to the MLE. Within the MAC-ACCESS used to carry the AL-SETUP on the uplink, the MS may include a "Reservation Request" for the total number of slots needed to transfer the datagram. The MAC-RESOURCE used to carry the AL-SETUP response on the downlink may include a "Slot Granting" element to reserve the required number of time slots for the MS on the uplink. The SwMI may also decide to increase the capacity of the PDCH (depending on the value of the field "Number of timeslots used per TDMA frame" in the AL-SETUP received from the MS) by including in the MAC-RESOURCE a "Channel Allocation element" with "allocation type" = 00 (see clause 23.5.4.2.1 and its clauses of the present document). Once the advanced link has been successfully established, the SNDTCP service users in the MS and SwMI shall be notified using the SN-QoS indication primitive. With the advanced link successfully established, the MS may then begin sending the SN-DATA PDU.

Refer clause 28.3.4.6 on the channel change protocol.



**Figure 196: Successful advanced link set-up, initiated by pending inbound data transfer**

In figure 197 the establishment of the advanced link is initiated by the arrival at the SwMI SNDCP entity of a SN-DATA (or SN-UNITDATA) request primitive. The SwMI shall send a SN-DATA TRANSMIT REQUEST PDU on the downlink using the unacknowledged basic link service. The basic link message shall be transported using a MAC-RESOURCE which shall contain a "Channel Allocation" element sending the MS either to a single slot PDCH or to a multislot PDCH if enhanced service was indicated in the "Resource request" information element in the SN-DATA TRANSMIT REQUEST PDU. Once on the PDCH, the MS shall establish an advanced link. This is achieved through the sending of a MLE-CONNECT request to the MLE. Within the MAC-ACCESS used to carry the AL-SETUP on the uplink, the MS may include a "Reservation Request" for the total number of slots needed to transfer the datagram. The MAC-RESOURCE used to carry the AL-SETUP response on the downlink may include a "Slot Granting" element to reserve the required number of time slots for the MS on the uplink. The SwMI may also decide to increase the capacity of the PDCH (depending on the value of the field "Number of timeslots used per TDMA frame" in the AL-SETUP received from the MS) by including in the MAC-RESOURCE a "Channel Allocation element" with "allocation type"= 00 (see clause 23.5.4.2.1 and its clauses of the present document). Once the advanced link has been successfully established, the SNDCP service users in the MS and SwMI shall be notified using the SN-QoS indication primitive. With the advanced link successfully established, the SwMI may then begin sending the SN-DATA PDU (or SN-UNITDATA PDU).

Refer clause 28.3.4.6 on the channel change protocol.

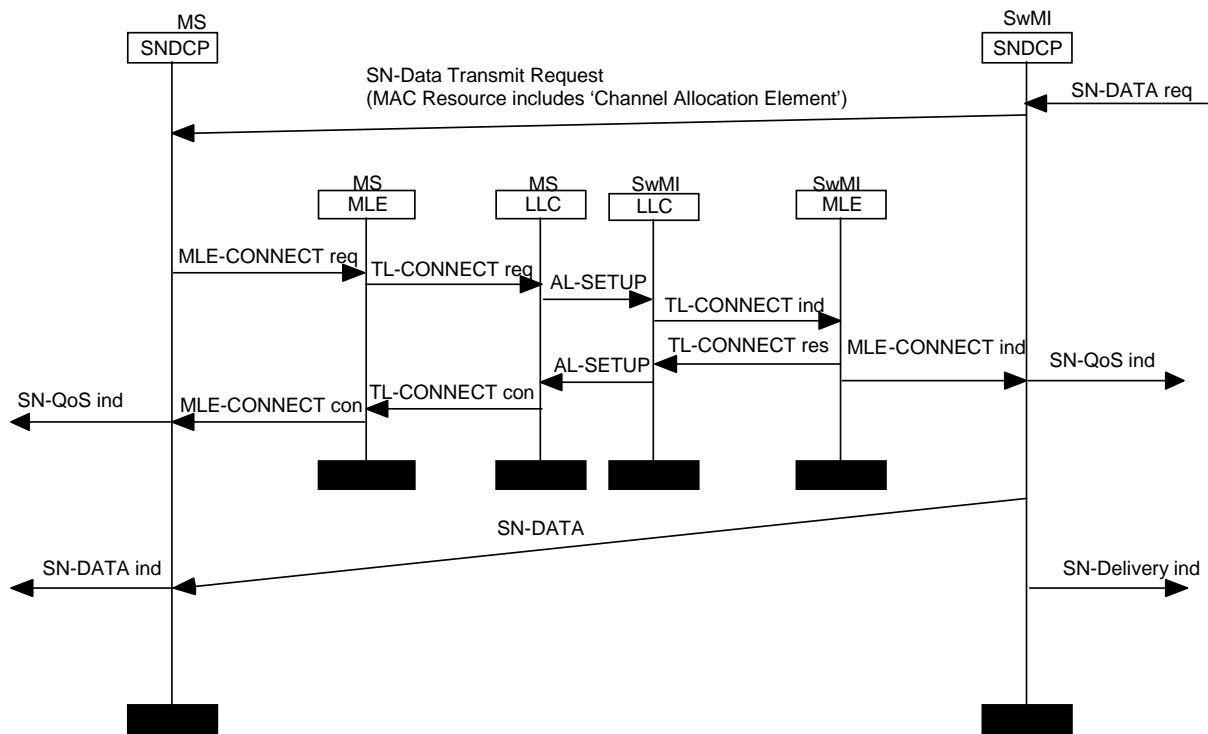


Figure 197: Successful advanced link set-up, initiated by pending outbound data transfer

Figure 198 shows the case where the establishment of the advanced link fails due to the QoS being offered by the SwMI, being lower than the minimum QoS which the MS is willing to accept.

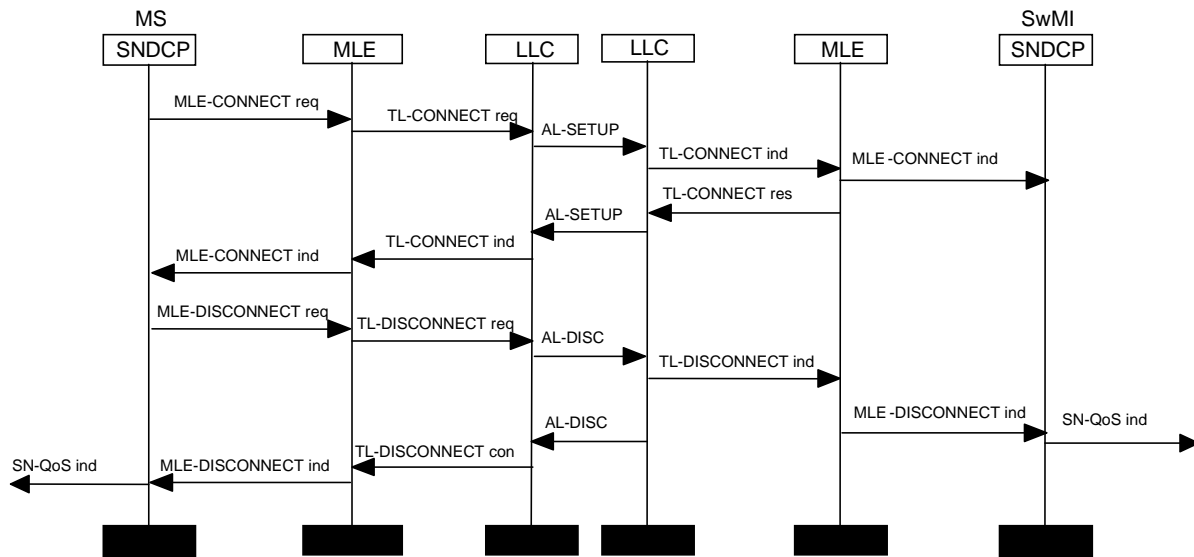


Figure 198: Failed advanced link setup - too low QoS offered by SwMI

Figure 199 shows the case where the establishment of the advanced link succeeds, after the MS accepts a lower QoS to that originally requested.

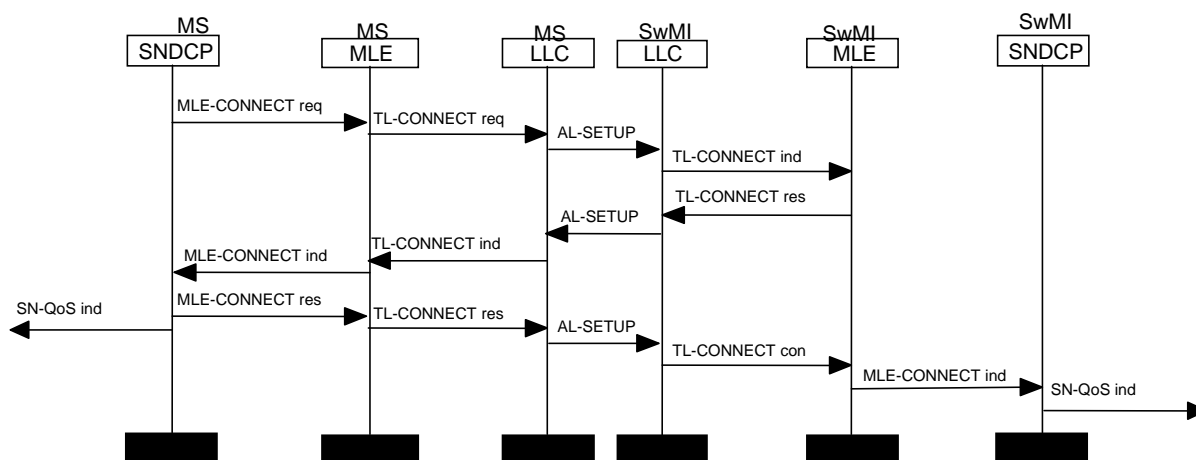


Figure 199: Successful advanced link setup - lower QoS accepted

#### b) Resetting an active advanced link

At any time both peer entities, MS and SwMI, may reset the advanced link in order to change QoS parameters.

NOTE 1: The SwMI should not reset the advanced link QoS Number of timeslots to a higher value than the last received advanced link setup initiated by the MS i.e. the upwards QoS negotiation should be limited to the value indicated by the MS.

NOTE 2: The SwMI may use temporarily less resources than negotiated in the advanced link setup. This is indicated in the channel allocation element and does not thus need advanced link reset. This is, however, against the QoS negotiation and should be used only because the SwMI does not temporarily have enough resources to fulfil the QoS demand. If the lack of resources is permanent, then the advanced link should be reset to a reasonable QoS value.

#### c) MS returns from READY Temporary Break state after recovering from radio downlink failure

The MS Sndcp entity shall re-establish the advanced link if the following three conditions are true:

1. The MS Sndcp entity is in READY Temporary Break state and receives a MLE-RESUME indication from the MLE.
2. There are SN-DATA PDUs (either uplink or downlink) or SN-UNITDATA (downlink) pending for transmission.
3. The MS does not support advanced link roaming (see clause 28.3.4.4).

Where a MS Sndcp entity, which is in READY Temporary Break state, receives a MLE-RESUME indication from the MLE, it is the responsibility of the MS Sndcp entity to firstly notify the SwMI Sndcp entity that it has regained access to the underlying resources (e.g. cell reselection has completed). This notification is carried out by sending a SN-RECONNECT PDU on the uplink.

NOTE: This SN-RECONNECT PDU is of most use when a SwMI is engaged in data transfer on the downlink to a MS and the MS switches cell. The SN-RECONNECT PDU is an efficient means by which the SwMI Sndcp entity can discover the cell change and re-route data accordingly.

The SN-RECONNECT PDU shall be transmitted using the acknowledged basic link service. The SN-RECONNECT PDU includes a field "Data to Send" which indicates if the MS has SN-DATA PDUs awaiting transmission. Upon successful transmission of the SN-RECONNECT PDU with "Data to Send" = 0 (thus indicating that the MS has no data to send), the MS shall stop the READY timer, start the STANDBY timer and enter state STANDBY. Upon successful transmission of the SN-RECONNECT PDU with "Data to Send" = 1 (thus indicating that the MS has data to send), the MS shall stop the READY timer, start the STANDBY and RESPONSE\_WAIT timers and enter state RESPONSE-WAITING. On reception of the SN-RECONNECT PDU, the SwMI Sndcp entity shall stop the READY timer, start the STANDBY timer and enter state STANDBY. The SwMI Sndcp entity shall check if the MS has indicated within the SN-RECONNECT PDU that it has a pending SN-DATA PDU for transfer on the uplink. The SwMI Sndcp shall also check to see if there is a pending SN-DATA PDU for transfer on the downlink. The message (if any), sent on the downlink by the Sndcp entity is shown in table 369.

**Table 369: Message sent by SwMI in response to SN-RECONNECT from MS**

<b>MS has SN-DATA PDU pending</b>	<b>SwMI has SN-DATA or SN-UNITDATA a pending</b>	<b>SwMI response</b>
No	no	no response
Yes	no	SN-DATA TRANSMIT RESPONSE
No	yes	SN-DATA TRANSMIT REQUEST
Yes	yes	SN-DATA TRANSMIT RESPONSE

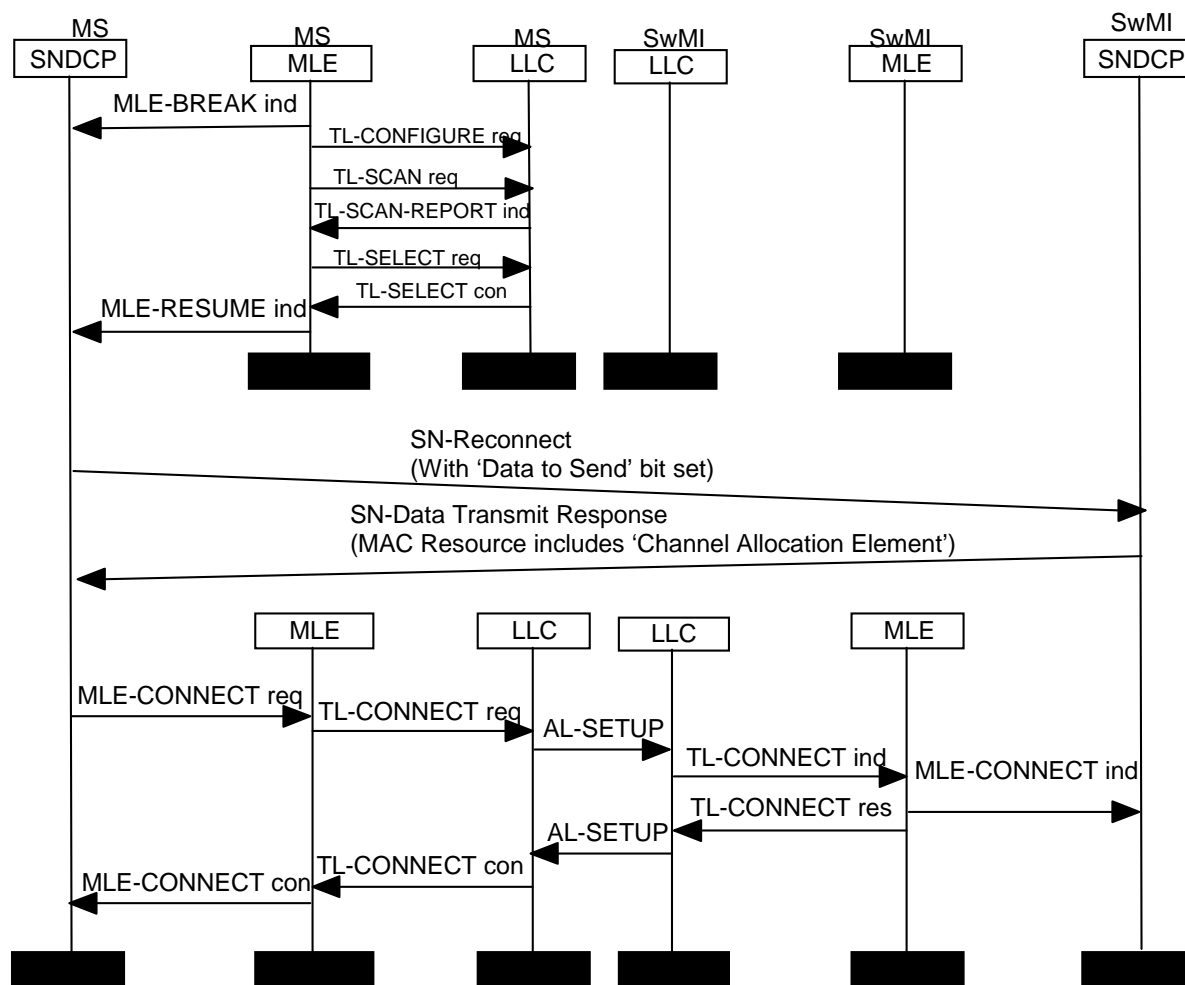
The SwMI may include a channel allocation in the SN-DATA TRANSMIT REQUEST or SN-DATA TRANSMIT RESPONSE, sending the MS to the PDCH. Once on the PDCH the MS shall re-establish the advanced link.

Figure 200 presents the case where the MS has data to send and re-establishes the advanced link once on the PDCH.

In this case, the MS Sndcp entity is in state READY Temporary Break and receives a MLE-RESUME indication from the MLE, thus indicating that access to the communication resources has become available again. It sends a SN-RECONNECT PDU to the SwMI Sndcp entity, stops the READY timer, starts the STANDBY and RESPONSE\_WAIT timers and enters RESPONSE-WAITING state. On reception of the SN-RECONNECT PDU, the SwMI stops the READY timer, starts the STANDBY timer and enters STANDBY state. The SwMI on seeing that the MS has indicated in the SN-RECONNECT PDU that it has a SN-DATA PDU awaiting transfer on the uplink, shall respond with a SN-DATA TRANSMIT RESPONSE PDU.

The SN-DATA TRANSMIT RESPONSE PDU is sent using the unacknowledged basic link service. Where the MS (after recovering from the radio downlink failure) is on a common control channel (MCCH or SCCH), the MAC-RESOURCE which contains this message shall include a "Channel Allocation" element directing the MS either to a single slot PDCH or to a multislot PDCH if enhanced service was indicated in the SN-RECONNECT PDU. On transmission of the SN-DATA TRANSMIT RESPONSE PDU, the SwMI shall stop the STANDBY timer, start the READY timer and enter READY state. On reception of the SN-DATA TRANSMIT RESPONSE PDU, the MS shall stop the STANDBY and RESPONSE\_WAIT timers, start the READY timer and enter READY state.

On the PDCH, the MS must re-establish the advanced link. This is achieved through the sending of a MLE-CONNECT request to the MLE. Within the MAC-ACCESS used to carry the AL-SETUP on the uplink, the MS may include a "Reservation Request" for the total number of slots needed to transfer any pending data. The MAC-RESOURCE used to carry the AL-SETUP response on the downlink may include a "Slot Granting" element to reserve time slots for the MS on the uplink. The MAC-RESOURCE may also decide to increase the capacity of the PDCH (depending on the value of the field "Number of timeslots used per TDMA frame" in the AL-SETUP received from the MS) by including a "Channel Allocation element" with "allocation type"= 00 (see clause 23.5.4.2.1 and its clauses of the present document).



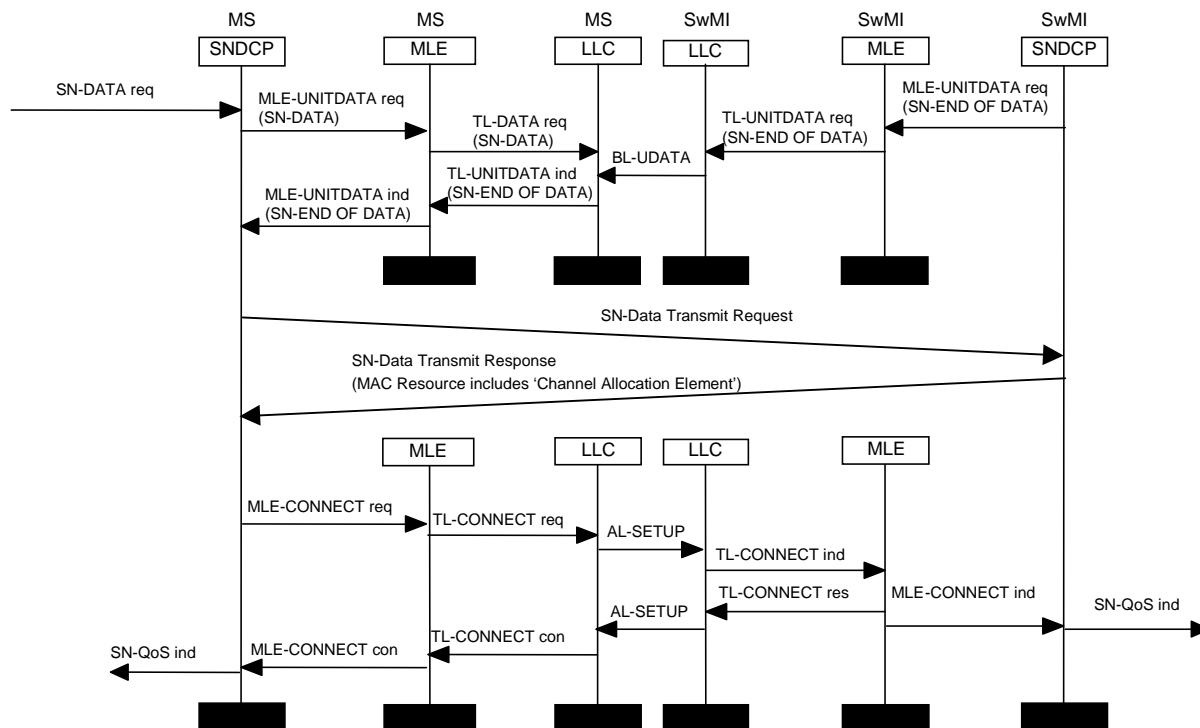
**Figure 200: Advanced link set-up after a radio downlink failure, with MS in READY state**

d) Failure to send a N-PDU

After receiving an MLE-REPORT indication indicating failure sending a N-PDU the MS or SwMI shall reset the advanced link. This reset is required by the SNDTCP user application and compression mechanisms expecting a reliable link. This link reset is required when even a single datagram is lost. This applies for both the MS and SwMI i.e. the SwMI should reset the advanced link when it recognises failure sending a N-PDU.

Where the MS SNDTCP entity receives a SN-END OF DATA PDU from the SwMI (effectively moving the MS off the PDCH), prior to reception of a MLE-REPORT indicating whether the transmission of a SN-DATA PDU was successful or not, then the MS shall reset the advanced link and notify the service user with a SN-DELIVERY indication, of the failure to send the SN-DATA. This scenario is shown in figure 201.

In the example, a MS passes a SN-DATA PDU to the lower layers. It then receives a SN-END OF DATA from the peer SNDTCP entity in the SwMI. As the MS has not yet had confirmation (in the form of a MLE-REPORT) that the previous SN-DATA was successfully transmitted, it resets the advanced link. Before sending the AL-SETUP with a reason "Reset", the MS sends SN-DATA TRANSMIT REQUEST PDU to the SwMI in order to get to the PDCH where it can re-establish the advanced link.



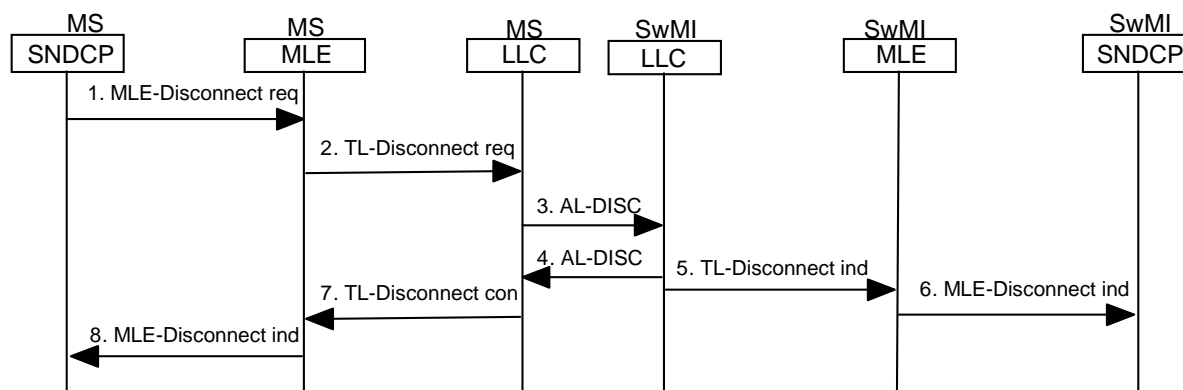
**Figure 201: Resetting advanced link after reception of SN-END OF DATA prior to completing transfer of previous SN-DATA**

### 28.3.4.3 Logical Link disconnection

The advanced link is disconnected after the last PDP context deactivation as shown in figure 202. The disconnection is triggered by the MS. In case of MS originated PDP context deactivation procedure (e.g. the SN-SAPI user has triggered PDP context deactivation by issuing SN-NSAPI dealloc request), the MS shall first disconnect the advanced link explicitly and after advanced link disconnection start the actual PDP context deactivation procedure as defined in clause 28.3.3.6.1. In case of SwMI originated PDP context deactivation procedure, the MS shall trigger advanced link disconnection in reception of a SN-DEACTIVATE PDP CONTEXT DEMAND PDU from the SwMI and shall not respond by a SN-DEACTIVATE PDP CONTEXT ACCEPT PDU until advanced link is explicitly disconnected.

NOTE 1: If the MS has initiated the advanced link disconnection, it should not accept packet data service any more.

NOTE 2: In case the STANDBY timer expires, the advanced links may be exceptionally released implicitly without sending AL-DISC PDUs.



**Figure 202: Disconnecting advanced link before the last PDP context deactivation**

#### 28.3.4.4 Advanced link reconnection

In an attempt to improve the performance of packet data transfer during cell reselection, a SwMI may allow a MS to maintain its advanced link as it roams between cells. The ability for a MS to continue using an advanced link on a new cell with all parameters, variables and timers carried from the previous cell is called advanced link roaming. It is optional for a MS or SwMI to support advanced link roaming. Advanced link roaming is initiated by the MS, by requesting the reconnection of the advanced link on the new cell. The SwMI shall respond to this request by indicating if the request has been accepted or rejected. The reconnection of the advanced link shall only be initiated by the MS. The MS SNDCP entity shall only attempt to reconnect an advanced link if the following two events have occurred:

1. The MS SNDCP entity has transmitted a SN-RECONNECT PDU after successful cell handover;

NOTE 1: The MS SNDCP entity only sends a SN-RECONNECT PDU if it was in READY state prior to cell handover taking place.

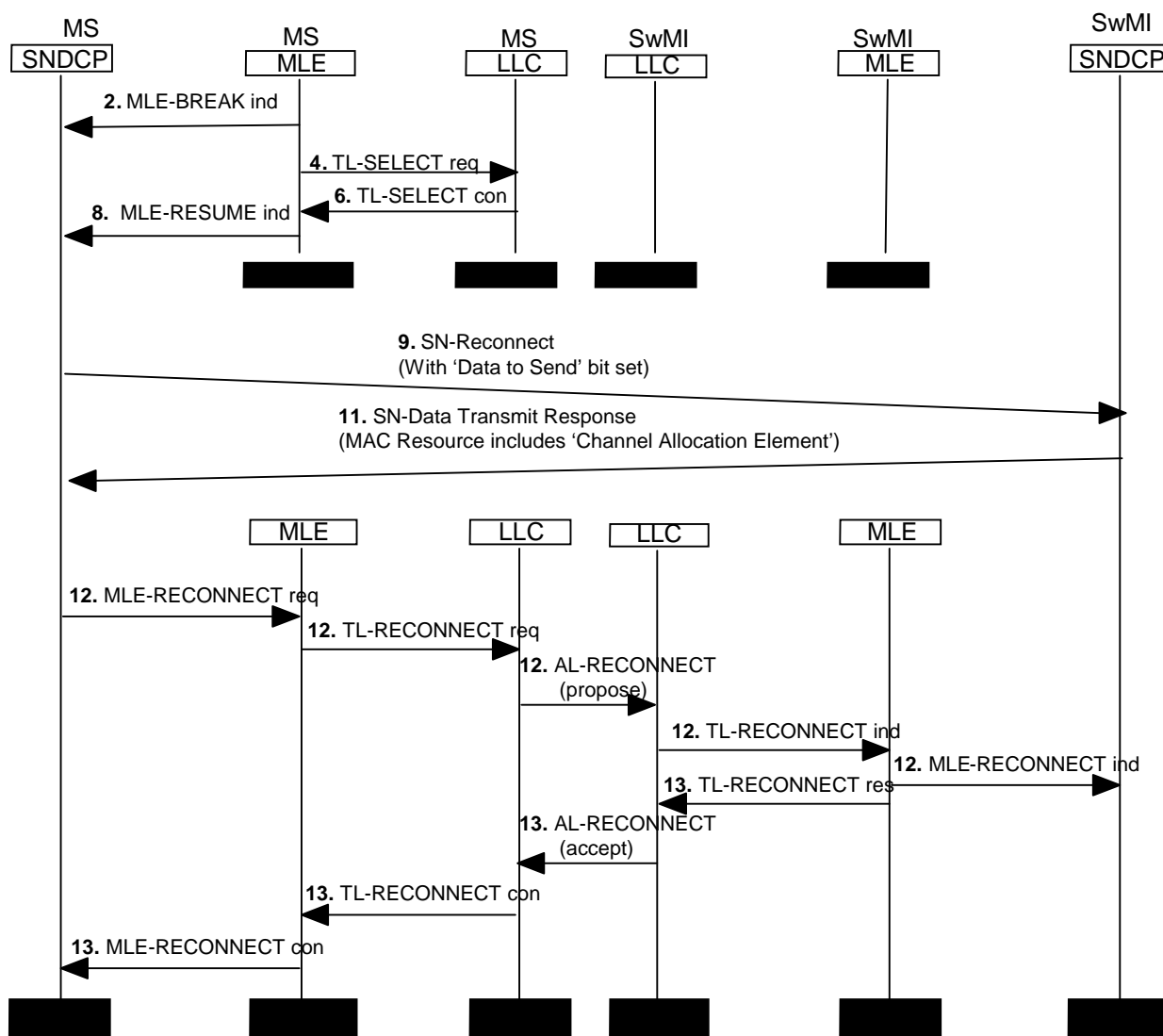
2. The MS has received a SN-DATA TRANSMIT RESPONSE PDU accepting the request or a SN-DATA TRANSMIT REQUEST PDU in response to the SN-RECONNECT and moved to the PDCH.

If both the above are true and the MS supports advanced link roaming, then the MS SNDCP entity may issue a MLE-RECONNECT request primitive to the MLE which shall be forwarded to the LLC as a TL-RECONNECT request primitive. The LLC shall build an AL-RECONNECT PDU with reconnect report value "propose" and send it to the SwMI. If the SwMI recognises the AL-RECONNECT PDU it shall respond with an AL-RECONNECT PDU. In this PDU the SwMI shall indicate if it supports advanced link roaming or not by the reconnect report value "accept" or "reject" respectively. Reception of the AL-RECONNECT PDU from the SwMI shall result in the MS LLC passing a TL-RECONNECT confirm primitive to the MLE and in turn a MLE-RECONNECT confirm primitive being passed to the SNDCP entity. Based on the response from the SwMI, the MS SNDCP entity at this point will know if the advanced link has been successfully reconnected or not.

Refer to clause 28.3.4.6 on the channel change protocol.

Figure 203 presents the case where both the MS and SwMI support advanced link roaming and where the MS is in ready state with data to transmit when the cell reselection procedures begin.





NOTE: Each message number in the figure above has a number associated with it which corresponds to the numbers of the bullet points in the description below.

**Figure 203: Successfully reconnecting the advanced link after cell reselection. Both MS and SwMI support advanced link roaming**

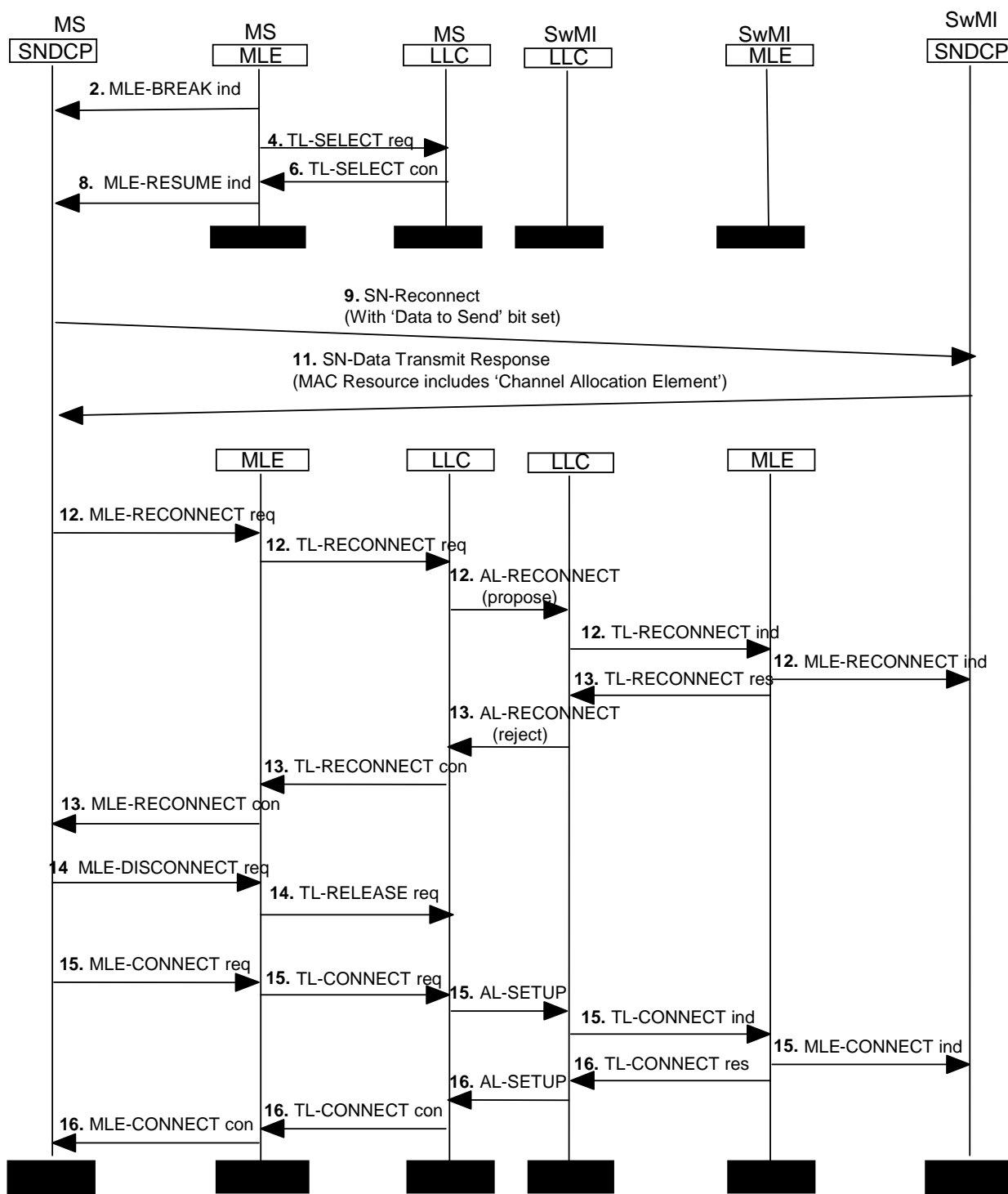
- 1) Signal quality begins to fall -> MLE decides to switch cell.
- 2) MLE sends MLE-BREAK indication to SNDSCP.
- 3) As the MS supports advanced link roaming, the MLE will not disconnect the advanced link (i.e. a TL-RELEASE request is not sent to the LLC).
- 4) MLE sends TL-SELECT request to the LLC requesting the MAC to switch to the main carrier of the new cell.
- 5) LLC forwards this as a TMC-SELECT request to the MAC (not shown).
- 6) The MAC switches to the MCCH of the new cell and issues a TMC-SELECT confirm to the LLC which is then passed to the MLE as a TL-SELECT confirm.
- 7) MM performs registration (V+D) if required (not shown).
- 8) MLE sends MLE-RESUME indication to SNDSCP.

- 9) SNDCP sends a SN-RECONNECT PDU to the SwMI. If there is data awaiting transmission in the SNDCP buffer, or if the SNDCP entity is aware that a partially transmitted TL-SDU is in the LLC buffers (i.e. one which has not yet been fully transmitted or one for which an acknowledgement has not yet been received from the peer entity), then the "Data to Send" field in the SN-RECONNECT PDU will be set to True else the "Data to Send" field will be set to False. In this case the Data to Send field is set to True.
- 10) The MS SNDCP entity enters RESPONSE-WAITING state, stops the READY timer and starts the STANDBY and RESPONSE-WAIT timers.
- 11) On reception of a SN-DATA TRANSMIT RESPONSE PDU from the SwMI, the MS shall switch to the PDCH and enter READY state.

NOTE 2: If for some reason the MS does not receive a SN-DATA TRANSMIT RESPONSE PDU prior to the RESPONSE\_WAITING timer expires or if a SN-DATA TRANSMIT RESPONSE PDU is received with Accept/Reject = 0 (i.e. requested is rejected), then SNDCP should attempt to initiate local disconnection of the advanced link.

- 12) SNDCP requests that the advanced link is reconnected by passing MLE-RECONNECT request primitive to the MLE which in turn passes a TL-RECONNECT request to the LLC. The LLC sends an AL-RECONNECT PDU with the reconnect report set to "propose" to the SwMI.
- 13) The SwMI responds with an AL-RECONNECT PDU, indicating that advanced link roaming is supported by setting the reconnect report set to "accept". The MS may now continue transmitting or receiving LLC segments from where it left off on the previous cell.

Figure 204 presents the case where the MS attempts to reconnect the advanced link on the new cell, but the SwMI rejects this request.



**Figure 204: Failure to reconnect the advanced link after cell reselection. SwMI does not support advanced link roaming**

- 1) Signal quality begins to fall -> MLE decides to switch cell.
- 2) MLE sends MLE-BREAK indication to SNDCP.
- 3) As the MS supports advanced link roaming, the MLE will not disconnect the advanced link (i.e. a TL-RELEASE request is not sent to the LLC).
- 4) MLE sends TL-SELECT request to the LLC requesting the MAC to switch to the main carrier of the new cell.
- 5) LLC forwards this as a TMC-SELECT request to the MAC (not shown).

- 6) The MAC switches to the MCCH of the new cell and issues TMC-SELECT confirm to the LLC which is then passed to the MLE as a TL-SELECT confirm.
- 7) MM performs registration (V+D) if required (not shown).
- 8) MLE sends MLE-RESUME indication to SNDCP.
- 9) SNDCP shall send a SN-RECONNECT PDU to the SwMI. If there is data awaiting transmission in the SNDCP buffer, or if the SNDCP entity is aware that a partially transmitted TL-SDU is in the LLC buffers (i.e. one which has not yet been fully transmitted or one for which an acknowledgement has not yet been received from the peer entity), then the "Data to Send" field in the SN-RECONNECT PDU will be set to True. Else the "Data to Send" field will be set to False. In this case it is assumed the Data to Send field is set to True.
- 10) The MS SNDCP entity enters RESPONSE-WAITING state, stops the READY timer and starts the STANDBY and RESPONSE-WAIT timers.
- 11) On reception of a SN-DATA TRANSMIT RESPONSE PDU from the SwMI, the MS shall switch to the PDCH and enter READY state.

NOTE 3: If for some reason the MS does not receive a SN-DATA TRANSMIT RESPONSE PDU prior to the RESPONSE\_WAITING timer expires or if a SN-DATA TRANSMIT RESPONSE PDU is received with Accept/Reject = 0 (i.e. requested is rejected), then SNDCP should attempt to initiate local disconnection of the advanced link.

- 12) SNDCP requests that the advanced link is reconnected by passing MLE-RECONNECT request primitive to the MLE which in turn passes a TL-RECONNECT request to the LLC. The LLC sends an AL-RECONNECT PDU to the SwMI with the reconnect report set to "propose".
- 13) The SwMI responds with an AL-RECONNECT PDU, indicating that advanced link roaming is not supported by setting the reconnect report to "reject".
- 14) In order to reset the LLC advanced link state machine, the SNDCP entity shall pass a MLE-DISCONNECT request to the MLE which in turn passes a TL-RELEASE request primitive to the LLC.
- 15) The SNDCP entity now requests that the advanced link is reset by passing MLE-CONNECT request primitive to the MLE which in turn passes a TL-CONNECT request to the LLC. The LLC sends an AL-SETUP PDU to the SwMI.
- 16) The SwMI responds with an AL-SETUP PDU indicating the resetting of the advanced link. The MS may now begin transmitting or receiving packet data.

#### 28.3.4.5 Releasing the advanced link

Where a MS does support advanced link roaming, and where the SNDCP entity receives a MLE-BREAK indication while in standby state, then on reception of a corresponding MLE-RESUME indication, the SNDCP entity shall locally disconnect any existing advanced link by issuing a MLE-DISCONNECT request to the MLE.

#### 28.3.4.6 Physical channel handling

In the TETRA protocol model MAC layer may request upper layers to decide whether a physical channel change is performed as proposed by BS to support a network layer service. This allows application layers to negotiate which service is selected when there is a conflict between various services e.g. ongoing speech service and packet data service. The details of the negotiation are outside the scope of the present document. The MLE layer provides the channel change request to the SNDCP as a "channel change response requested" parameter in conjunction with a "Channel change handle" parameter, refer to clause 17.3.5. If the channel change is acceptable on all services point of view the SNDCP shall response to that request by issuing an MLE-CONFIGURE request with the parameter "change accept".

In the SNDCP protocol descriptions this is implied by requirements such as "the MS shall switch to the PDCH".

## 28.3.5 Packet Data transmission and reception procedures

This clause describes the procedures within SNDCP for transmitting and receiving packet data. Acknowledged and unacknowledged services are available for packet data transfer. Unacknowledged data transfer is only supported on the downlink. This clause also defines compression techniques which may be used during data transfer as a way of improving efficiency.

### 28.3.5.1 Acknowledged data service

The basic setting for sending N-PDUs between MS and SwMI is to use acknowledged service.

A scenario illustrating acknowledged data sending from SwMI to MS is shown in figure 205. Each numbered step is explained in the following list.

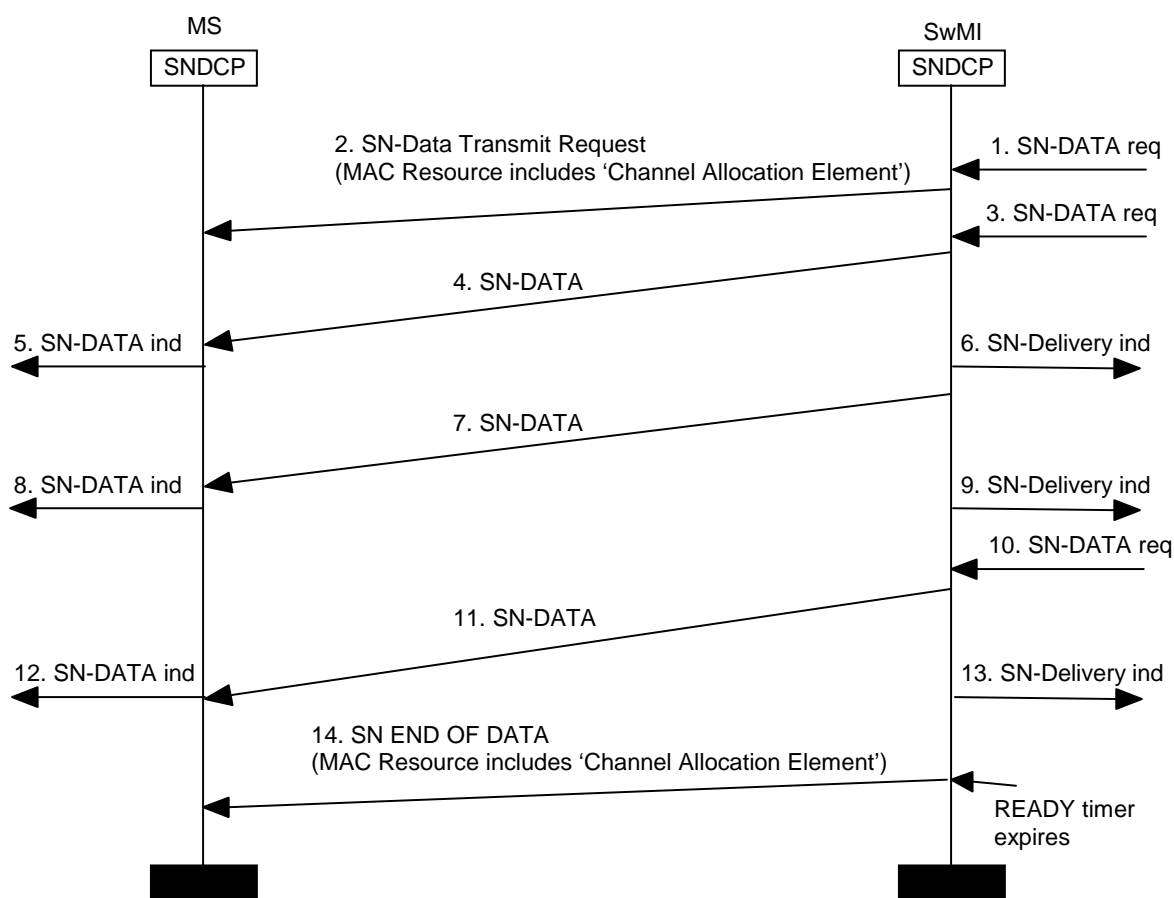
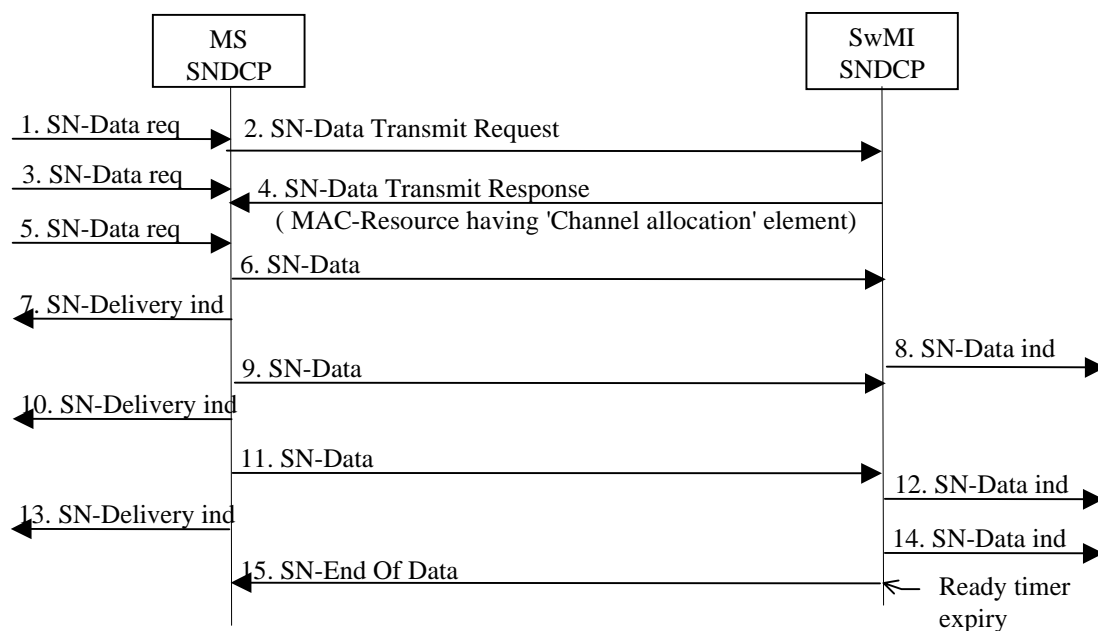


Figure 205: Acknowledged service, data from SwMI to MS

1. The SwMI SNDCP receives the first SN-DATA request.
2. The SwMI SNDCP sends SN-DATA TRANSMIT REQUEST PDU. The request is sent by using unacknowledged service (basic link) and the MAC-RESOURCE PDU contains a "Channel Allocation" element sending the MS to a PDCH (The type of PDCH, i.e. the number of time slots per TDMA frame, shall depend on the currently established advanced link). On transmission of the SN-DATA TRANSMIT REQUEST PDU, the SwMI stops the STANDBY timer, starts the READY timer and enters state READY. On reception of the SN-DATA TRANSMIT REQUEST PDU, the MS stops the STANDBY timer, starts the READY timer and enters state READY.
3. The SwMI SNDCP receives the second SN-DATA request.
4. The first N-PDU is sent to the MS by issuing SN-DATA PDU. On reception of an indication from the MLE, in the form of an MLE-REPORT indication, that the SN-DATA PDU was successfully transmitted by the lower layers, the SwMI SNDCP entity shall restart the READY timer. At the MS the reception of the SN-DATA PDU shall result in the READY timer being restarted.
5. After receiving the first SN-DATA PDU the MS SNDCP passes the N-PDU to the higher layer by issuing a SN-DATA indication.
6. After receiving acknowledgement that the first SN-DATA PDU was successfully sent to the MS the SwMI sends SN-DELIVERY indication to the higher layer.
7. The second N-PDU is sent to the MS by issuing SN-DATA PDU. The READY timer is re-started in the SwMI SNDCP and in the MS SNDCP.
8. After receiving the second SN-DATA PDU the MS SNDCP passes the N-PDU to the higher layer by issuing a SN-DATA indication.
9. After receiving acknowledgement that the second SN-DATA PDU was successfully sent to the MS the SwMI sends SN-DELIVERY indication to the higher layer.
10. The SwMI SNDCP receives the third SN-DATA request.
11. The third N-PDU is sent to the MS by issuing SN-DATA PDU. The READY timer is re-started in the SwMI SNDCP and in the MS SNDCP.
12. After receiving the third SN-DATA PDU the MS SNDCP passes the N-PDU to the higher layer by issuing SN-DATA indication.
13. After receiving acknowledgement that the third SN-DATA PDU was successfully sent to the MS the SwMI sends SN-DELIVERY indication to the higher layer.
14. The READY timer expires in the SwMI SNDCP and it issues SN-END OF DATA PDU, including channel allocation, to the MS, starts the STANDBY timer and enters STANDBY state. The MS SNDCP receives SN-END OF DATA PDU, stops its READY timer, starts the STANDBY timer and enters STANDBY state on the indicated channel.

A scenario illustrating acknowledged data sending from MS to SwMI is shown in figure 206. Each numbered step is explained in the following list.

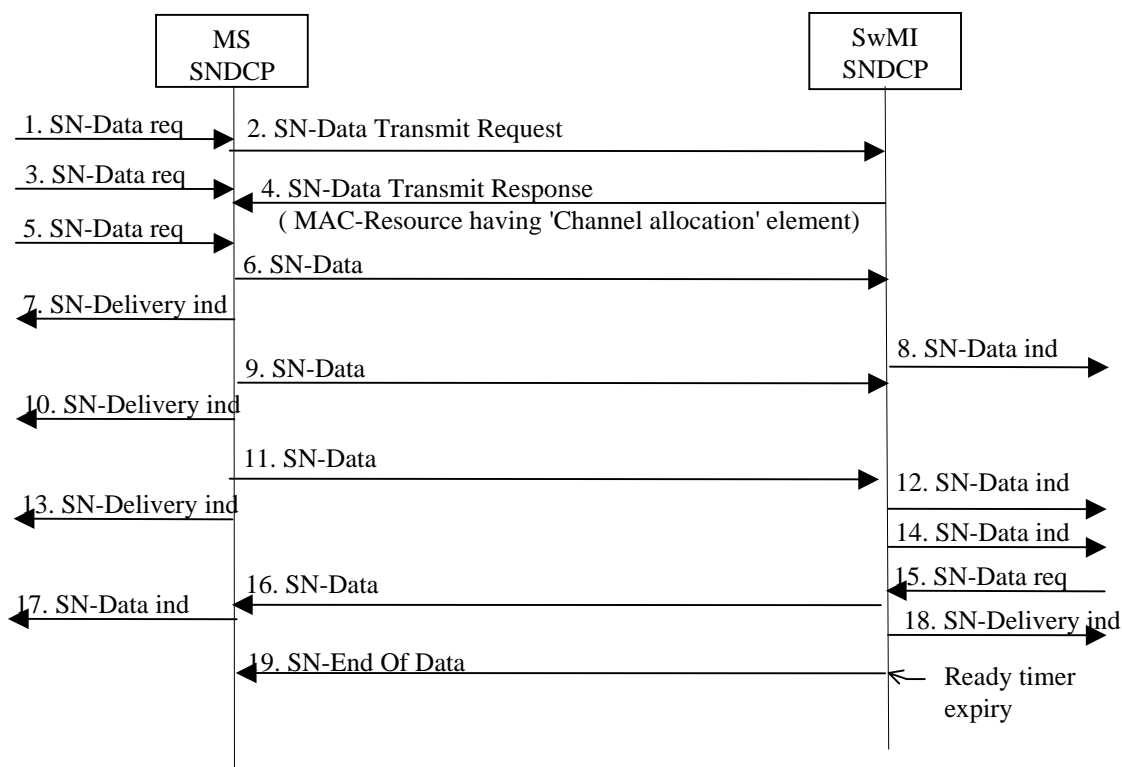


**Figure 206: Acknowledged service, data from MS to SwMI**

1. The MS SNDCP receives the first SN-DATA request.
2. The MS SNDCP sends SN-DATA TRANSMIT REQUEST PDU. The request is sent by using acknowledged service (basic link). On sending the SN-DATA TRANSMIT REQUEST PDU, the MS SNDCP entity, starts the RESPONSE\_WAIT timer and enters RESPONSE-WAITING state.
3. The MS SNDCP receives the second SN-DATA request.
4. The SwMI SNDCP sends SN-DATA TRANSMIT RESPONSE PDU. The response is sent by using unacknowledged service (basic link) and the MAC-level MAC-RESOURCE PDU contains channel allocation element commanding the MS to PDCH. On transmission of the SN-DATA TRANSMIT RESPONSE PDU, the SwMI stops the STANDBY timer, starts the READY timer and enters state READY. On reception of the SN-DATA TRANSMIT RESPONSE PDU, the MS stops the STANDBY and RESPONSE\_WAIT timers, starts the READY timer and enters state READY.
5. The MS SNDCP receives the third SN-DATA request.
6. The first N-PDU is sent to the SwMI by issuing SN-DATA PDU. On reception of an indication from the MLE, in the form of an MLE-REPORT indication, that the SN\_DATA PDU was successfully transmitted by the lower layers, the MS SNDCP entity shall restart the READY timer. At the SwMI the reception of the SN-DATA PDU shall result in the READY timer being restarted.
7. After receiving acknowledgement that the first SN-DATA PDU was successfully sent to the SwMI, the MS sends SN-DELIVERY indication to the higher layer.
8. After receiving the first SN-DATA PDU, the SwMI SNDCP passes the N-PDU to the higher layer by issuing SN-DATA indication.
9. The second N-PDU is sent to the SwMI by issuing SN-DATA PDU. The READY timer is re-started in the MS SNDCP and in the SwMI SNDCP.
10. After receiving acknowledgement that the second SN-DATA PDU was successfully sent to the SwMI, the MS sends SN-DELIVERY indication to the higher layer.
11. The third N-PDU is sent to the SwMI by issuing SN-DATA PDU. The READY timer is re-started in the MS SNDCP and in the SwMI SNDCP.
12. After receiving the second SN-DATA PDU, the SwMI SNDCP passes the N-PDU to the higher layer by issuing SN-DATA indication.

13. After receiving acknowledgement that the third SN-DATA PDU was successfully sent to the SwMI, the MS sends SN-DELIVERY indication to the higher layer.
14. After receiving the third SN-DATA PDU the SwMI SNDSCP passes the N-PDU to the higher layer by issuing SN-DATA indication.
15. The READY timer expires in the SwMI SNDSCP and it issues SN-END OF DATA PDU, including channel allocation, to the MS, starts the STANDBY timer and enters STANDBY state. The MS SNDSCP receives SN-END OF DATA PDU, stops its READY timer, starts the STANDBY timer and enters STANDBY state in the allocated channel.

A scenario illustrating acknowledged data sending from MS to SwMI and from SwMI to MS is shown in figure 207. Each numbered step is explained in the following list.



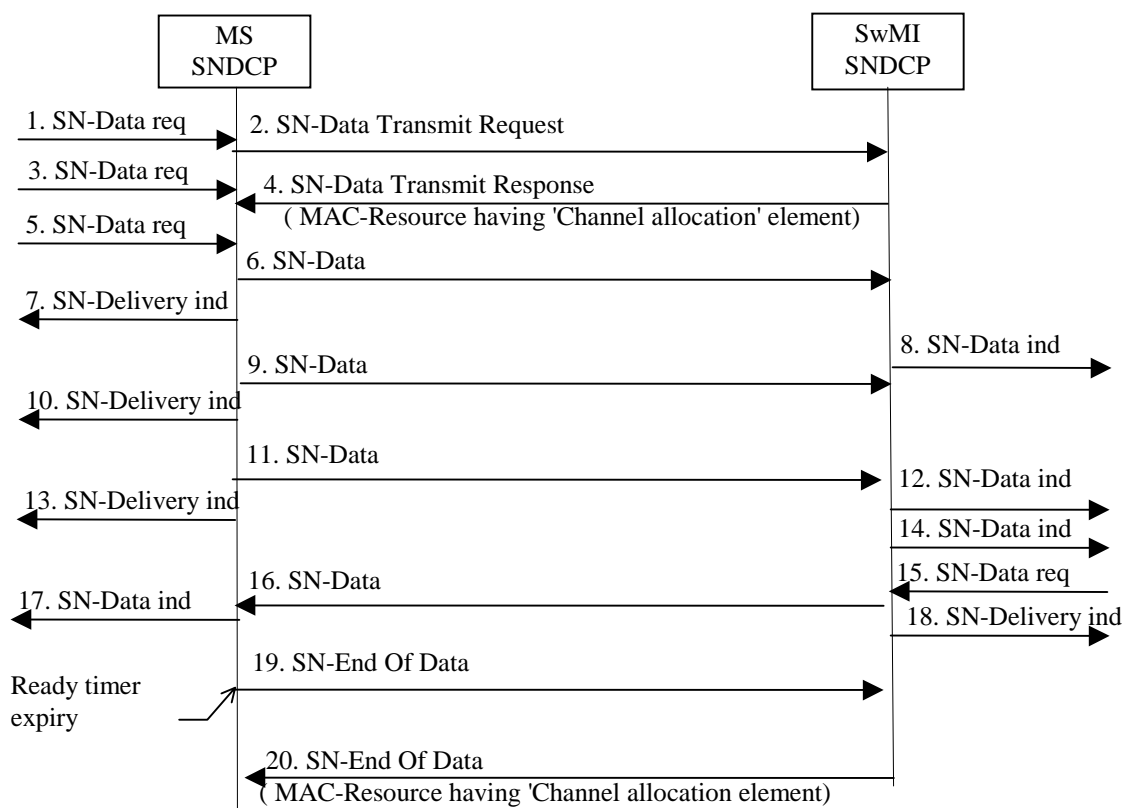
**Figure 207: Acknowledged service, data from MS to SwMI and from SwMI to MS**

1 to 14 These steps as in figure 206 "acknowledged service, data from MS to SwMI".

15. The SwMI SNDSCP receives the first (and only one in this scenario) SN-DATA request.
16. The first N-PDU is sent to the MS by issuing SN-DATA PDU. On reception of an indication from the MLE, in the form of an MLE-REPORT indication, that the SN\_DATA PDU was successfully transmitted by the lower layers, the SwMI SNDSCP entity shall restart the READY timer. At the MS, the reception of the SN-DATA PDU shall result in the READY timer being restarted.
17. After receiving the first SN-DATA PDU, the MS SNDSCP passes the N-PDU to the higher layer by issuing SN-DATA indication.
18. After receiving acknowledgement that the first SN-DATA PDU was successfully sent to the MS, the SwMI sends SN-DELIVERY indication to the higher layer.
19. The READY timer expires in the SwMI SNDSCP and it issues SN-END OF DATA PDU, including channel allocation, to the MS, starts the STANDBY timer and enters STANDBY state. The MS SNDSCP receives SN-END OF DATA PDU, stops its READY timer, starts the STANDBY timer and enters STANDBY state on the allocated channel.

A scenario illustrating Ready timer expiry in the MS is shown in figure 208. Each numbered step is explained in the following list.



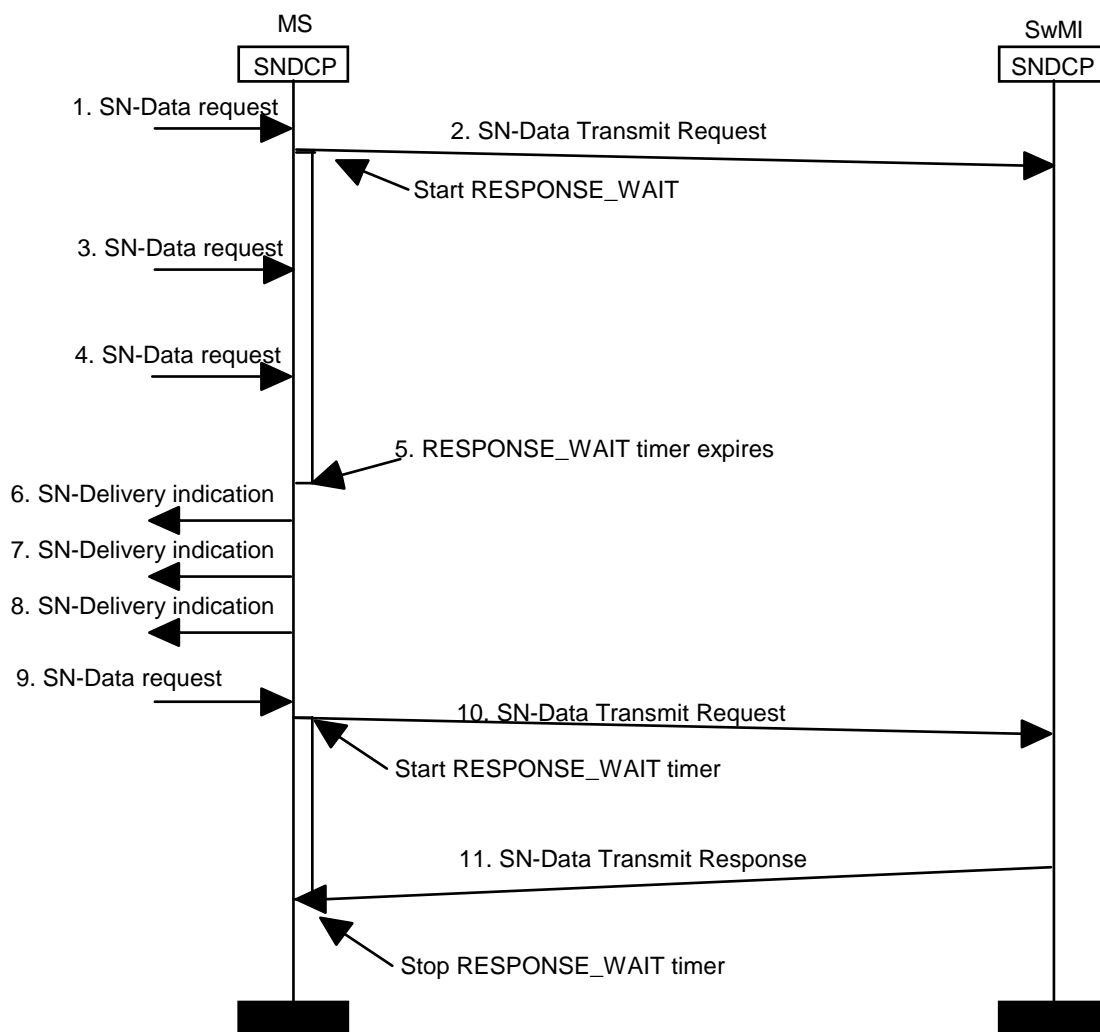


**Figure 208: Acknowledged service, READY timer expiry in the MS**

1 to 14 These steps are the same as in figure 206 "acknowledged service, data from MS to SwMI".

15. The SwMI SNDPCP receives the first (and only one in this scenario) SN-DATA request.
16. The first N-PDU is sent to the MS by issuing SN-DATA PDU. The READY timer is started in the SwMI SNDPCP (when the SN-DATA PDU is successfully sent) and in the MS SNDPCP (when the SN-DATA PDU is received).
17. After receiving the first SN-DATA PDU the MS SNDPCP passes N-PDU to the higher layer by issuing SN-DATA indication.
18. After receiving acknowledgement that the first SN-DATA PDU was successfully sent to the MS the SwMI sends SN-Delivery indication to the higher layer.
19. The READY timer expires in the MS SNDPCP and it issues SN-END OF DATA PDU to the SwMI. The MS restarts the READY timer.
20. After receiving SN-END OF DATA PDU from the MS SNDPCP the SwMI SNDPCP issues SN-END OF DATA PDU, including channel allocation, to the MS, starts the STANDBY timer and enters STANDBY state. The MS SNDPCP receives SN-END OF DATA PDU, stops its READY timer, starts the STANDBY timer and enters STANDBY state on the allocated channel.

A scenario illustrating RESPONSE\_WAIT timer expiry in the MS is shown in figure 209. Each numbered step is explained in the following list.



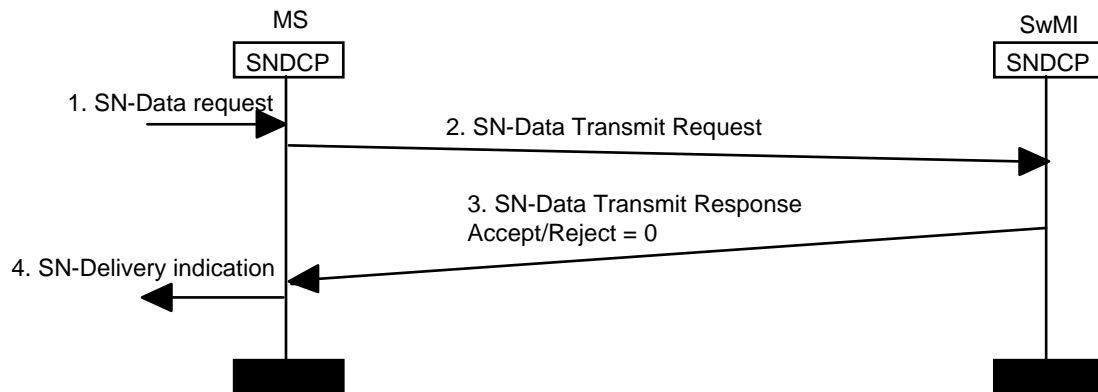
NOTE: The present document does not define the number of SN-DATA request primitives which may be buffered in the MS while the RESPONSE\_WAIT timer is active.

**Figure 209: Acknowledged service, RESPONSE\_WAIT timer expiry in the MS**

1. The service user issues a SN-DATA request primitive to the MS Sndcp entity.
2. The MS Sndcp entity transmits a SN-DATA TRANSMIT REQUEST PDU, starts the RESPONSE\_WAIT timer and enters RESPONSE-WAITING state.
3. The service user issues a second SN-DATA request primitive to the MS Sndcp entity.
4. The service user issues a third SN-DATA request primitive to the MS Sndcp entity.
5. The RESPONSE\_WAIT timer expires. The MS Sndcp entity enters STANDBY state.
6. The MS Sndcp entity issues a SN-DELIVERY indication primitive to the service user, giving notification that the SN-DATA request received in 1) has failed.
7. The MS Sndcp entity issues a SN-DELIVERY indication primitive to the service user, giving notification that the SN-DATA request received in 3) has failed.
8. The MS Sndcp entity issues a SN-DELIVERY indication primitive to the service user, giving notification that the SN-DATA request received in 4) has failed.
9. The service user issues a new SN-DATA request primitive to the MS Sndcp entity.

10. The MS SNDCP entity transmits a SN-DATA TRANSMIT REQUEST PDU, starts the RESPONSE\_WAIT timer and enters RESPONSE-WAITING state.
11. The MS SNDCP entity receives a SN-DATA TRANSMIT RESPONSE (with Accept/Reject = 1). The RESPONSE\_WAIT and STANDBY timers are stopped READY state is entered. The MS may now send the N-PDUs received from the service user, using SN-DATA PDUs as described in the previous examples.

A scenario illustrating SwMI rejecting a request from the MS is shown in figure 210. Each numbered step is explained in the following list.



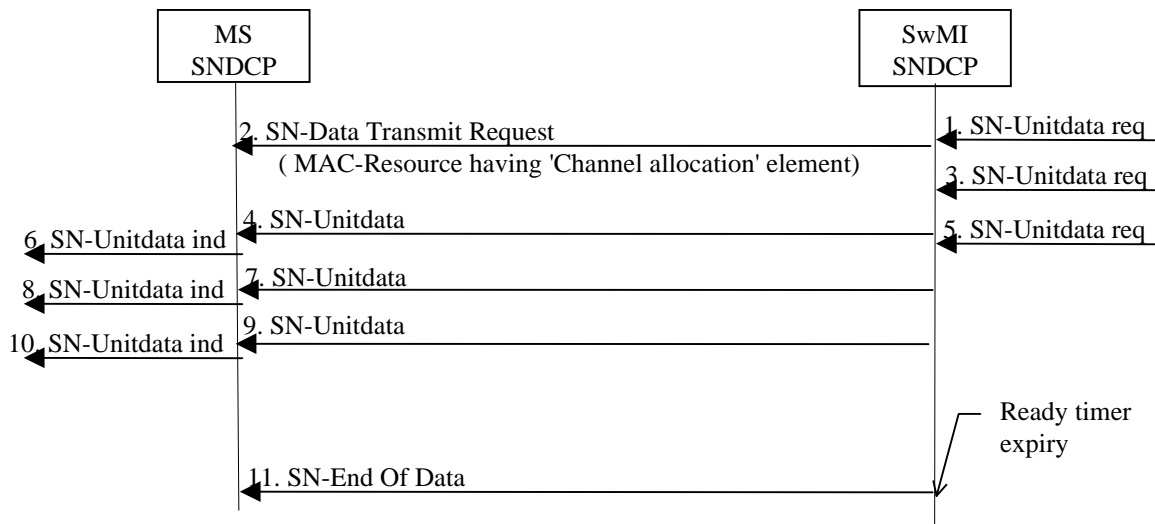
**Figure 210: Acknowledged service, SwMI rejects request**

1. The service user issues a SN-DATA request primitive to the MS SNDCP entity.
2. The MS SNDCP entity transmits a SN-DATA TRANSMIT REQUEST PDU, starts the RESPONSE\_WAIT timer and enters RESPONSE-WAITING state.
3. Due to heavy system loading the SwMI rejects the request. The SwMI delivers a SN-DATA TRANSMIT RESPONSE PDU to the MS, with Accept/Reject set to "Request rejected by the SwMI", and "Transmit Response Reject Cause" set to "System resources not available". The MS stops its RESPONSE\_WAIT timer, restarts the STANDBY timer and enters STANDBY state.
4. The MS SNDCP entity issues a SN-DELIVERY indication primitive to the service user, giving notification that the SN-DATA request received in 1) has failed.

### 28.3.5.2 Unacknowledged data service

The SwMI may use also unacknowledged service to send N-PDUs. The procedures for unacknowledged data transfer differ from those of acknowledged data transfer when the destination is a group address. The READY timer is not activated when an MS enters READY state for reception of point to multipoint packet data. Also the reception of a point to multipoint datagram does not effect any of the SNDCP timers.

A scenario illustrating unacknowledged data sending from SwMI to MS is shown in figure 211. Each numbered step is explained in the following list.



**Figure 211: Unacknowledged service, data from SwMI to MS**

1. The SwMI SNDPC receives the first SN-UNITDATA request.
2. The SwMI SNDPC sends SN-DATA TRANSMIT REQUEST PDU. The request is sent by using unacknowledged service (basic link) and the MAC-RESOURCE PDU contains channel allocation element commanding the MS to PDCH. The STANDBY timer is stopped and the READY timer is started in the SwMI SNDPC (when the SN-DATA TRANSMIT REQUEST PDU is sent). The STANDBY timer is stopped in the MS SNDPC (when the SN-DATA TRANSMIT REQUEST PDU is received).
3. The SwMI SNDPC receives the second SN-UNITDATA request.
4. The first N-PDU is sent to the MS by issuing SN-UNITDATA PDU. On reception of an indication from the MLE, in the form of an MLE-REPORT, that the SN-UNITDATA PDU was transmitted by the lower layers, the SwMI SNDPC entity shall restart the READY timer.
5. The SwMI SNDPC receives the third SN-UNITDATA request.
6. After receiving the first SN-UNITDATA PDU, the MS SNDPC passes the N-PDU to the higher layer by issuing SN-UNITDATA indication.
7. The second N-PDU is sent to the MS by issuing SN-UNITDATA PDU. The READY timer is re-started in the SwMI SNDPC.
8. After receiving the second SN-UNITDATA PDU, the MS SNDPC passes the N-PDU to the higher layer by issuing SN-UNITDATA indication.
9. The third N-PDU is sent to the MS by issuing SN-UNITDATA PDU. The READY timer is re-started in the SwMI SNDPC.
10. After receiving the third SN-UNITDATA PDU, the MS SNDPC passes N-PDU to the higher layer by issuing SN-UNITDATA indication.
11. The READY timer expires in the SwMI SNDPC and it issues SN-END OF DATA PDU, including channel allocation, to the MS, starts the STANDBY timer and enters STANDBY state. The MS SNDPC receives SN-END OF DATA PDU, starts the STANDBY timer and enters STANDBY state on the allocated channel.

### 28.3.5.2a Usage of Resource request

The MS SNDCP entity may request enhanced service in PDCH access signalling. That may be indicated by using Enhanced service information element in SN-DATA TRANSMIT REQUEST (data from MS to SwMI), SN-PAGE RESPONSE (data from SwMI to MS) or SN-RECONNECT PDU transmitted to the peer entity. If enhanced service is indicated in the PDU, the PDU shall also contain a conditional Resource request information element, which shall inform the SwMI of the desired bandwidth of the PDCH. Unlike other QoS parameters, bandwidth parameters shall be informed to the SwMI before the MS has already been directed to a PDCH. In consequence this shall aid the SwMI in directing the MSs to the proper channels and access to resources, where the actual data transfer occurs, is immediate.

If the MS requests multislot connection and Resource request element is not used at all, the MS has to be directed to a single slot channel to do the advanced link set-up, then after advanced link negotiation to the actual multislot channel to do the data transfer. In this case the MS visits completely uselessly on a single slot channel for a short time. If the indication of the multislot packet data is done earlier by using Resource request element, the MS can be moved directly to a desired multislot channel and latency time to the resource access can be reduced.

As default the connection shall always be single slot connection. If the MS requests single slot connection, the enhanced service does not have to be indicated in PDCH access signalling. Then the SwMI shall send the MS to single time slot PDCH and if no advanced link exists, the MS shall establish a single slot advanced link on the PDCH. Anyway the MS shall be on the channel where the actual data transfer occurs.

If no advanced link exists when the MS has been sent to a PDCH, the MS SNDCP entity shall use the bandwidth parameters, which were indicated in Resource request element also during the advanced link set-up negotiation.

If an advanced link has already been established for the packet data service when the MS enters from STANDBY state to READY state (i.e. MS has visited on the PDCH at least once before), the MS shall adapt the requested width of the PDCH in PDCH access signalling with the already negotiated advanced link parameters.

NOTE 1: The MS should always use Resource request information element in PDCH access signalling if more than one timeslot is requested to either direction on the PDCH.

NOTE 2: This element has only a meaning to reduce latency time to the actual multislot resource access preventing the visit to the single slot channel uselessly before the advanced link connection setup. The normal QoS negotiation between LLC peer entities may not be ignored.

Resource request element may be also used when dealing with single slot packet data operation. By indicating the requested data transfer throughput value before the MS is directed to the PDCH, the BS have a capability to optimise its resource allocations between several MSs on the same channel and direct them to the proper channels right away. Connection symmetry element indicates whether the same number of timeslots per TDMA frame shall be used both on uplink and downlink. In the case of symmetric connection, the next element, Number of timeslots on uplink, shall indicate the number of used slots both on uplink and downlink. In that case Number of timeslots on downlink element is not needed at all.

Instead if asymmetric connection is indicated by the Connection symmetry element, the element Number of timeslots on downlink is also present. Then the number of used timeslots on uplink and downlink shall be indicated by different elements.

NOTE 3: The actual protocol part of asymmetric connection is outside the scope of the present document, i.e. different timeslot requests on uplink and downlink are not used in this version of ETS.

Full capability on uplink and Full capability on downlink information elements shall indicate the MS's capability to handle physical resources. Any resource granting over these capability limits by the SwMI is useless, because the MS does not have physical capabilities to handle more timeslots in one TDMA frame than indicated by these elements.

NOTE 4: How the SwMI should handle the situation where more resources has been negotiated than indicated by capability limits is outside the scope of the present document.

### 28.3.5.3 Protocol header compression

#### 28.3.5.3.1 Header compression types

Header compression attempts to remove redundant protocol header information of transmitted PDUs between source and destination addresses. The used compression method is specific for each network layer protocol type. TCP/IP (IPv4) and IP (IPv4 and IPv6) header compression are introduced in the present document.

Multiple types of header compression are supported. Negotiation of supported algorithms is carried out between MS and SwMI in Activate PDP Context procedure, if necessary. The negotiation uses PCOMP negotiation element (8 bits bitmap) in SN-ACTIVATE PDP CONTEXT PDUs where as the control of the compression process is done by using PCOMP element (4 bits) in SN-DATA PDUs.

#### 28.3.5.3.2 TCP/IP header compression

IETF RFC 1144 [18] defines an encoding method and protocol for compressing the standard 40-octet TCP/IP (IPv4) protocol header down to 3 octets at minimum. The standard TCP/IP header comprises 20 octets of IP part and 20 octets of TCP part. The idea is to replace the IP header with a one octet connection number, and the TCP header with delta information (only differences are sent).

Due to the requirement that TCP/IP header compression operates over a reliable link, TCP/IP header compression shall not be used with the unacknowledged layer 2 service.

The protocol requires that the underlying service should be able to distinguish three types of IP frames. The frame type information is conveyed in the PCOMP field of the SNDCP header.

When compression is used, a TCP/IP header is replaced with a compressed header of length varying from 3 to 16 octets. Octet one carries a change mask that identifies which of the consequent fields has changed per-packet. A mask bit is set if the associated field is changed and present in the header. The corresponding bit is clear if there are no changes, and the delta field is absent. The unmodified TCP checksum field, however, is always included in the compressed header. The format of the header is shown in table 370.

**Table 370: Compressed header format**

Bit	8	7	6	5	4	3	2	1
Octet 1	0	C	I	P	S	A	W	U
2	Connection number (C)							
3	TCP checksum							
4								
..	Urgent pointer (U)							
..	delta (Window) (W)							
	delta (Ack) (A)							
	delta (Sequence) (S)							
N	delta (IP ID) (I)							

The connection information table in each connection entity shall be initialised upon occurrence of:

- Initial LLC connection establishment/release; or
- At any time when the SNDCP entity concludes that the peer entity has lost TCP/IP header compression synchronization.

NOTE: Where an MS moves to a new cell and establishes an advanced link, there should not be a need for the connection information table to be re-initialised.

In TETRA packet data, each SNDCP entity maintains two connection state tables per PDP context, one for datagrams sent (compressor state table) and one for datagrams received (decompressor state table). Within each table there may be up to 256 state slots, thus allowing the compression of up to 256 simultaneous TCP connections per PDP context. The exact number of state slots supported by SNDCP entities is negotiated at context activation. The MS shall specify in the SN-ACTIVATE PDP CONTEXT DEMAND PDU the number of state slots which it can support for this context. The SwMI shall respond in the SN-ACTIVATE PDP CONTEXT ACCEPT PDU with either the same value or a lower value. The lower of the values specified in the SN-ACTIVATE PDP CONTEXT DEMAND PDU and SN-ACTIVATE PDP CONTEXT ACCEPT PDU shall be used by both SNDCP entities. It is recommended at least 16 state slots are supported per PDP context. It is also recommended that implementations should avoid specifying one slot during PDP context activation if possible.

### 28.3.5.3.3 IP header compression

IETF RFC 2507 [51] and IETF RFC 2508 [52] define an encoding method and protocol for compressing multiple types of IPv4 or IPv6 protocol header(s). This includes UDP/IP headers, which can be compressed down to 3 octets at minimum. The idea is as for the TCP/IP header compression described in clause 28.3.5.3.2 to replace the IP header(s) with a one or two octet context number, and required delta information (only differences are sent).

The protocol requires that the underlying service should be able to distinguish nine types of IP frames. The frame type information is conveyed in the PCOMP field of the SNDCP header.

In TETRA packet data, each SNDCP entity maintains two context state tables per PDP context, one for datagrams sent (compressor context state table) and one for datagrams received (decompressor context state table). Within each table there may be up to 256 + 65 536 context state slots, thus allowing the compression of up to 256 simultaneous TCP connections and 65 536 simultaneous non-TCP "contexts" per PDP context. The exact number of state slots supported by SNDCP entities is negotiated at PDP context activation. The MS shall specify in the SN-ACTIVATE PDP CONTEXT DEMAND PDU the number of state slots which it can support for this context. The SwMI shall respond in the SN-ACTIVATE PDP CONTEXT ACCEPT PDU with either the same value or a lower value. The lower of the values specified in the SN-ACTIVATE PDP CONTEXT DEMAND PDU and SN-ACTIVATE PDP CONTEXT ACCEPT PDU shall be used by both SNDCP entities. It is recommended at least 16 state slots be supported per PDP context. It is also recommended that implementations should avoid specifying one slot during PDP context activation if possible.

The context information table in each entity shall be initialised upon occurrence of:

- initial LLC connection establishment/release; or
- at any time when the SNDCP entity concludes that the peer entity has lost IP header compression synchronisation.

NOTE: Where an MS moves to a new cell and establishes an advanced link, there should not be a need for the context information table to be re-initialised.

### 28.3.5.4 Data compression

Data compression in TETRA Packet data shall primarily be done according to the ITU-T Recommendation V.42bis [19]. It is also possible to use alternative compression methods, if required.

The supported alternative data compression methods introduced in the present document are:

- BSD Compression (IETF RFC 1977 [53]);
- Predictor Compression (IETF RFC 1978 [54]).

### 28.3.5.4.1 Support of multiple compression types

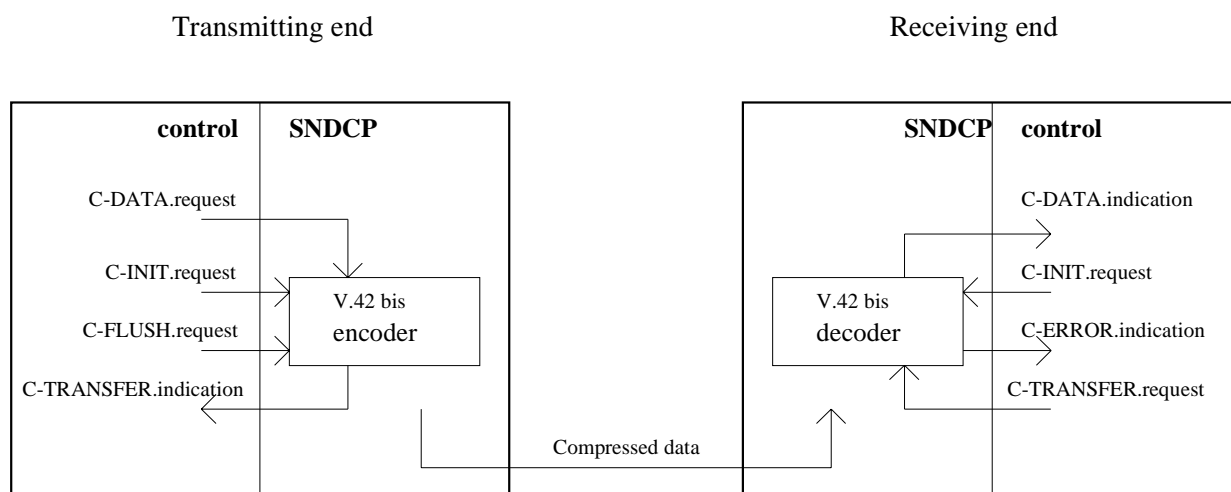
Each SNDCP entity shall be equipped with the ability to handle several compression types. Then, the means must be arranged between the peer SNDCP entities to negotiate and switch on the selected algorithm.

The negotiation of the supported algorithms needs to be done prior to data transfer, and it is done between the MS and SwMI in Activate PDP Context procedure. The MS sends a list of algorithms that it can support. The SwMI responds by picking up those algorithms on the list, which it accepts, and then returns a list of the permitted algorithms back to the MS. The format of the negotiation element is similar for both directions.

Any permitted compression algorithm can be switched on during data transfer period. The selected compression type is identified with DCOMP parameter, which is carried in SN-DATA or SN-UNITDATA PDU frames.

### 28.3.5.4.2 Management of V.42bis data compression

According to the present document the use of data compression function and associated parameters shall be negotiated at initial connection establishment. The negotiated parameters, P0, P1 and P2 shall be transferred between MS and SwMI.



**Figure 212: ITU-T Recommendation V.42bis data compression function**

The service interface of the ITU-T Recommendation V.42bis [19] data compression function is modelled as a set of abstract service primitives, figure 212. The control function at each end of data transfer shall issue a C-INIT request primitive to the data compression function after a successful negotiation of compression parameters and after completion of LLC link establishment.

To encode data, the SNDCP control function shall issue a C-DATA request primitive to the data compression function, indicating the data to be encoded. The encoder indicates with C-TRANSFER indication that the compressed data is ready to be delivered.

At the receiver end the encoded data block is delivered to the decoder unit using C-TRANSFER request. After this the decoder indicates by C-DATA indication that the decoded data block is ready to be moved further.

The C-FLUSH request primitive shall be used to preserve boundaries between network protocol data blocks (PDUs). The control function shall issue a C-FLUSH request immediately after encoding of each PDU.

The C-ERROR indication primitive informs the control function that an error has been detected by the decoder. The error situation is recovered by re-establishing the LLC connection.

Any subsequent PDP context activation, which requests, and is granted, ITU-T Recommendation V.42bis [19] compression support with different ITU-T Recommendation V.42bis [19] compression parameters, shall cause the ITU-T Recommendation V.42bis [19] compression dictionaries to be cleared.



### 28.3.5.4.3 Management of BSD data compression

The BSD data compression algorithm is described in IETF RFC 1977 [53]. This IETF RFC describes the compression algorithm and defines the encapsulation header. The encapsulation is shown in table 370A:

**Table 370A: BSD compressed data format**

Bit	8	7	6	5	4	3	2	1
Octet 1	Sequence							
2	Sequence (continued)							
3	Compressed data							
...etc.	...etc.							
N	Compressed data							

The compressed data element is the output of the BSD algorithm when applied to the original N-PDU content.

In TETRA packet data, each SNDCCP entity maintains two BSD compression dictionaries, one for datagrams sent (compressor dictionary) and one for datagrams received (decompressor dictionary). All BSD dictionaries shall be cleared at context activation.

If the decoder has detected an error, the error situation is recovered by re-establishing the LLC connection. According to the specification, the use of the BSD data compression function and associated parameters shall be negotiated at initial connection establishment. The negotiated parameters, version and dictionary size shall be transferred between MS and SwMI.

Any subsequent PDP context activation, which requests, and is granted, BSD compression support with different BSD compression parameters shall cause the BSD compression dictionaries to be cleared.

### 28.3.5.4.4 Management of Predictor data compression

The predictor data compression algorithm is described in IETF RFC 1978 [54]. This RFC describes the compression algorithm and defines two types of encapsulation headers. However, only type 1 encapsulation is allowed within the present document. The encapsulation is shown in table 370B:

**Table 370B: Predictor compressed data format**

Bit	8	7	6	5	4	3	2	1
Octet 1	Uncompressed length (octets)							
2	Uncompressed length (continued)							
3	Compressed data							
...etc.	...etc.							
...etc.	...etc.							
N	Compressed data							

The compressed data element is the output of the predictor algorithm when applied to the original N-PDU content with an appended 16 bit CRC. This CRC shall be calculated as defined in IETF RFC 1662 [55].

In TETRA Packet data, each SNDCCP entity maintains two predictor compression dictionaries, one for datagrams sent (compressor dictionary) and one for datagrams received (decompressor dictionary). All predictor dictionaries shall be cleared at context activation. If the decoder has detected an error, the error situation is recovered by re-establishing the LLC connection.

According to the specification, the use of the predictor data compression function shall be negotiated at initial connection establishment. There are no negotiated parameters for the predictor data compression.

### 28.3.6 Packet data paging mechanism

A paging mechanism has been defined within SNDCP to provide the following two functions:

- to allow a SwMI to determine the current location of a MS which is in state STANDBY (or state RESPONSE-WAITING), in order to deliver data;
- to provide a mechanism by which a SwMI may indicate that there is outbound data awaiting delivery to this MS and allow the MS to indicate whether it is available to accept this data.

There are two main scenarios where the paging mechanism may be used. Firstly where data arrives in the SwMI for a MS which is in STANDBY (or RESPONSE-WAITING) state, and if the SwMI is unsure of the exact location of the MS (e.g. due to there being multiple cells per registration area), then the SwMI may page the MS. Secondly where data arrives in the SwMI for a MS which is in STANDBY state, and the SwMI wishes to first check to see if the MS is available for packet data service, then the SwMI may page the MS. This second scenario may be useful when considering service interaction with Type B,C and D of MS. This paging mechanism allows a MS to decide whether it wishes to drop its current service in order to switch to the packet data service.

Upon reception of a page request from the SwMI, the MS SNDCP entity may act in four ways:

- 1) Where the SwMI indicates that no SNDCP response is requested, then the MS SNDCP entity shall take no further action;

NOTE 1: In this case the page request shall be carried using the basic link acknowledged service, hence by acknowledging this basic link message, the MS is implicitly responding to the page.

- 2) Where the SwMI indicates that a SNDCP response is requested, the MS SNDCP entity may respond indicating whether it is available or temporarily unavailable for packet data service. The MS may set the "Stealing Permission" parameter in the MLE-UNITDATA request, used to pass the SN-PAGE RESPONSE PDU to the MLE, to "steal immediately";
- 3) Where the MS does not have an active PDP context, the MS SNDCP entity may respond by the SN-DEACTIVATE PDP CONTEXT DEMAND PDU initiating the MS originated PDP context deactivation procedure (see clause 28.3.3.6.1).

NOTE 2: The MS may respond with the "Deactivation type" set to "Deactivate all NSAPIs" if no active PDP context exist. If PDP contexts do exist at the MS, the MS may respond with the "Deactivation type" set to "Deactivate NSAPI given in the PDU" if the NSAPI identified in the SN-PAGE REQUEST is not recognised by the MS.

Figure 213 shows the scenario where the MS SNDCP entity responds to a page received from the SwMI.

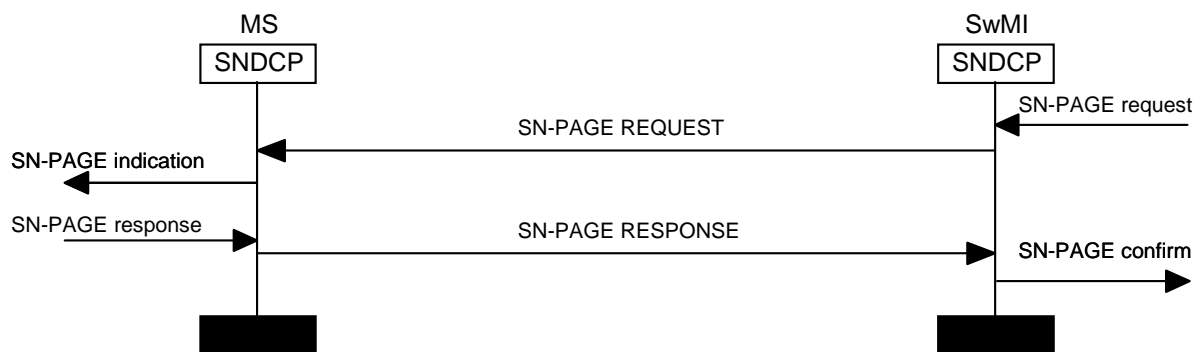
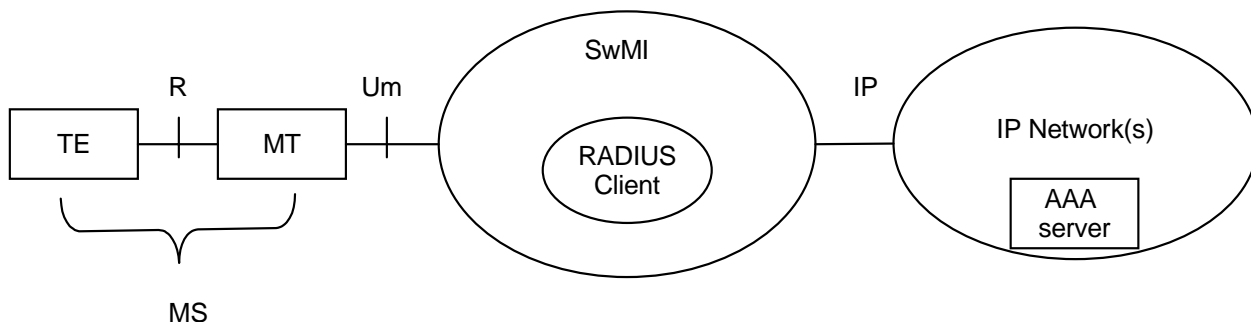


Figure 213: SwMI Pages MS, MS SNDCP entity responds

### 28.3.7 TETRA IP user authentication

The figure 214 illustrates the reference model of IP user authentication when using PPP and RADIUS protocols, refer to IETF RFC 1661 [21] and IETF RFC 2865 [23]. In the model an AAA server and the RADIUS protocol are used to verify the user access. Other alternatives for the model are also possible. For instance inside the SwMI there could be a user authentication entity to provide the same functionality as the external AAA server.

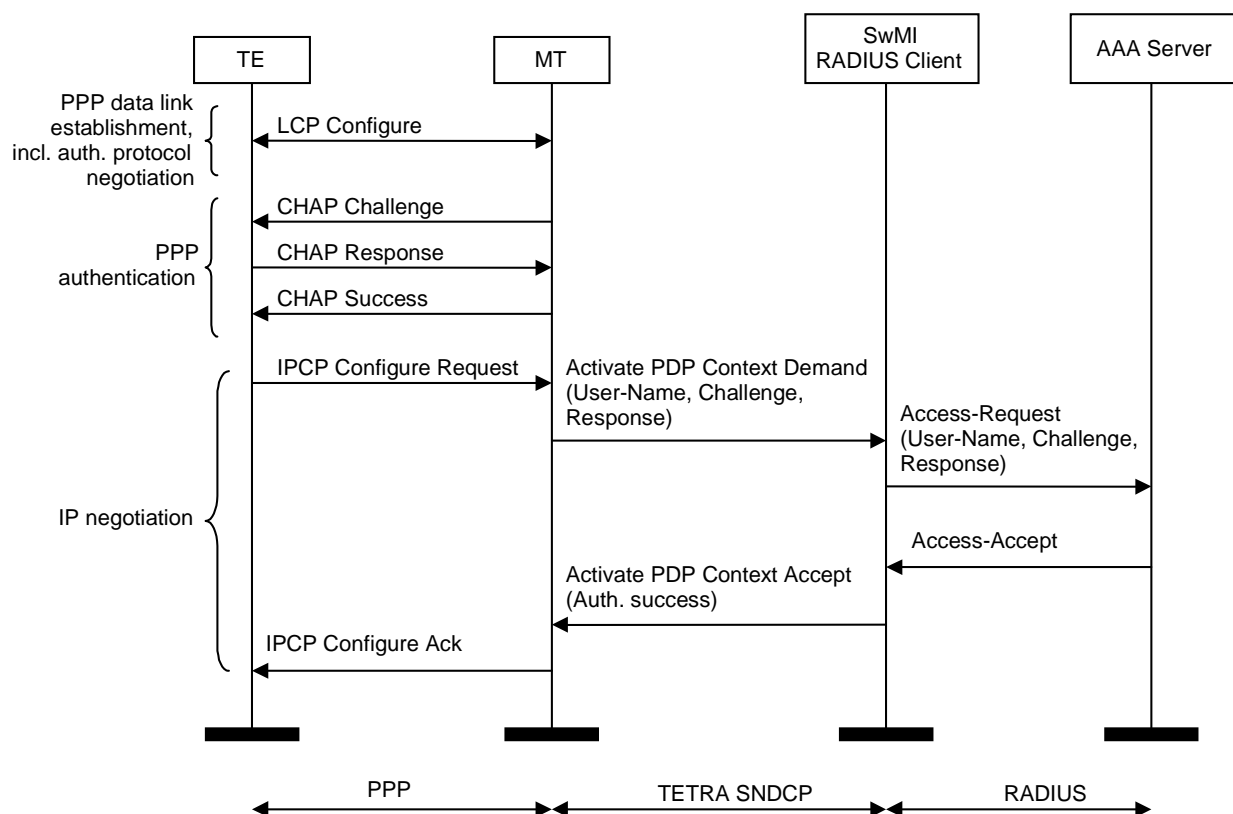


**Figure 214: IP user authentication model**

Following assumptions are made:

- PPP is the link layer protocol used between a TETRA Terminal Equipment (TE) and a TETRA Mobile Termination (MT);
- there is a requirement to authenticate the TE using PAP or CHAP, refer to IETF RFC 1994 [22];
- the TE is the peer that shall be authenticated, and the MT is the authenticator, using the terminology defined in ref. /4/;
- there is a requirement to support the PPP authentication with a centralised AAA server which is accessed by RADIUS protocol as defined in ref. /6/;
- the PAP or CHAP authentication information collected in the MT is forwarded over the TETRA Air Interface to the TETRA SwMI;
- inside the TETRA SwMI is a RADIUS client entity which forwards the authentication information to the external AAA server.

The figure 215 illustrates the phases of a packet data context setup upon a successful authentication with CHAP. Corresponding signalling using PAP authentication would be slightly more straightforward.



**Figure 215: A successful authentication with CHAP**

Following steps clarifies the figure above:

1. PPP/LCP negotiates the Maximum-Receive-Unit and authentication options;
2. When using CHAP (or PAP), the TE authenticates itself to the MT, which stores the information (username, challenge and response, or password when using PAP) and sends an accept to TE;
3. TE requests IP configuration from the MT using PPP/IPCP, either defining a static address, or requesting an address from the network;
4. MT sends an ACTIVATE PDP CONTEXT DEMAND PDU to SwMI, containing in the Protocol configuration option information element the authentication and configuration information it has collected;
5. RADIUS client in SwMI sends an Access-Request to AAA Server using RADIUS protocol;
6. AAA Server sends an Access-Accept to RADIUS Client;
7. SwMI sends an ACTIVATE PDP CONTEXT ACCEPT PDU to MT;
8. MT sends an IPCP Configure Ack to TE and the link is open (or dropped if negotiation failed).

### 28.3.8 TETRA Packet data over the air provisioning

As indicated in figure 214, the TETRA reference model in many ways resembles the reference model used by many IP service providers. Here, the PPP establishment mechanisms are used as a flexible, easily expandable way to provision essential information to the dial up client at connection establishment. Similar information is required at the TE/MT in the TETRA environment, and the TETRA standard therefore allows for such parameters to be provisioned to the TE/MT at context activation.

This information should be transferred to the TE/MT contained in an IPCP Configuration-Ack within the Protocol configuration options element in the SN-ACTIVATE PDP CONTEXT ACCEPT PDU. The SwMI may include IPCP configuration options specifying (but not limited to):

- Primary and secondary DNS servers;
- Primary and secondary NBNS servers.

The MT shall be prepared to receive Protocol configuration options elements with Protocol identity set to IPCP (8021H). The MT may ignore the IPCP protocol or IPCP configuration options.

NOTE: Ignoring received information is dissimilar to normal PPP behaviour but required here as the MT can not reject received information.

## 28.4 SN-PDU formats

The general format of the PDU encoding is as defined in annex E of the present document.

The elements shall be transmitted in the order specified by the table with the top element being transmitted first. The content of an information element is represented by a binary value and the most significant bit of that binary value shall be transmitted first.

The information contained in the PDU description tables which follow corresponds to the following key:

- Length: length of the element in bits;
- Type: element type (1, 2, or 3) as defined in clause 14.7;
- C/O/M: conditional/optional/mandatory information in the PDU;
- Remark: comment.

### 28.4.1 PDU priority

At the transmitting end the message priority management at SNDP level is done before any other operations. Each priority has its own queue that is mapped to the corresponding queue in LLC (MLE passes messages without changing their order). By doing so, for instance, a long file transfer PDU can be quickly bypassed by any other message that has a higher priority. Eight priority levels are used, number 7 representing the highest priority. The priorities for SN-PDUs shall be set according to table 371.

Table 371: PDU priority for SN-PDUs

SN-PDU	PDU priority
SN-ACTIVATE PDP CONTEXT DEMAND	4
SN-DEACTIVATE PDP CONTEXT DEMAND	4
SN-ACTIVATE PDP CONTEXT ACCEPT	4
SN-ACTIVATE PDP CONTEXT REJECT	4
SN-DEACTIVATE PDP CONTEXT ACCEPT	4
SN-UNITDATA	see note
SN-DATA	see note
SN-DATA TRANSMIT REQUEST	see note
SN-DATA TRANSMIT RESPONSE	see note
SN-RECONNECT	4
SN-PAGE REQUEST	4
SN-PAGE RESPONSE	4
SN-END OF DATA	4
SN-NOT SUPPORTED	4
NOTE: The maximum value for PDU priority is defined in SN-ACTIVATE PDP CONTEXT ACCEPT PDU "PDU priority max" element for each NSAPI. The value used in the MLE-UNITDATA request primitive is given in the SN-DATA/UNITDATA request primitive. If the value given by the higher layer is higher than the "PDU priority max" element indicates, then the PDU priority is decreased by the SMDCP to the value indicated in the "PDU priority max" element. If the value is not given in the SN-DATA/UNITDATA request primitive, then the SMDCP uses value indicated in the "PDU priority max" element.	

At the receiver end there is no need for queuing mechanism.

## 28.4.2 Maximum N-PDU size

The maximum N-PDU size is assigned by the SwMI at context activation using the parameter "Maximum transmission unit". This value represents the maximum N-PDU size which is allowed. This size refers to the maximum size of a N-PDU prior to the addition of the SMDCP header and the application of any compression.

The Maximum transmission unit should always be less than the Maximum size of a TL-SDU, which is negotiated during advanced link setup. Hence where the SwMI sets Maximum transmission unit to 1 500 octets at context activation, then the negotiated maximum size of TL-SDU at advanced link setup should be 2 048 octets.

## 28.4.3 PDU not supported

In case the receiving MS or SwMI SMDCP entity receives an unknown SN PDU, the receiving entity should sent the SN-NOT SUPPORTED PDU. The behaviour of the requesting party when receiving SN NOT SUPPORTED PDU is outside the scope of the present document. The meaning of this functionality is only to maintain backward compatibility of the systems.

## 28.4.4 SN PDU description tables

### 28.4.4.1 SN-ACTIVATE PDP CONTEXT ACCEPT

SN-ACTIVATE PDP CONTEXT ACCEPT PDU shall contain information elements as defined in table 372.

- Message: SN-ACTIVATE PDP CONTEXT ACCEPT PDU
- Response to: SN-ACTIVATE PDP CONTEXT DEMAND PDU
- Response expected: -
- Short description:

Table 372: SN-ACTIVATE PDP CONTEXT ACCEPT PDU contents

Information element	Length	Type	C/O/M	Remark
SN PDU type	4	1	M	
NSAPI	4	1	M	
PDU priority max	3	1	M	
READY timer	4	1	M	
STANDBY timer	4	1	M	
RESPONSE_WAIT timer	4	1	M	
Type identifier in accept	3	1	M	
IP Address IPv4	32		C	see note 1
PCOMP negotiation	8	1	M	
Number of Van Jacobson compression state slots	8		C	see note 2
Number of compression state slots, TCP	8		C	see note 3
Number of compression state slots, non-TCP	16		C	see note 3
Maximum interval between full headers	8		C	see note 3
Maximum time interval between full headers	8		C	see note 3
Largest header size in octets that may be compressed	8		C	see note 3
Maximum transmission unit	3	1	M	
SNDCP network endpoint identifier	16	2	O	see note 4
SwMI IPv6 information	98	2	O	
SwMI Mobile IPv4 information	71	2	O	
DCOMP negotiation	varies	3	O	see note 5
Protocol configuration options	varies	3	O	see note 6
<p>NOTE 1: Shall be conditional on the value of Type Identifier in Accept (TIA):</p> <ul style="list-style-type: none"> <li>- when TIA = 1 or 2 the information element shall be present;</li> <li>- for all other values of TIA the information element shall not be present.</li> </ul> <p>NOTE 2: Shall be conditional on the value of bit 1 (LSB) of PCOMP negotiation:</p> <ul style="list-style-type: none"> <li>- when bit 1 of PCOMP = 0 the information element shall not be present;</li> <li>- when bit 1 of PCOMP = 1 the information element shall be present.</li> </ul> <p>NOTE 3: Shall be conditional on the value of second LSB of PCOMP negotiation:</p> <ul style="list-style-type: none"> <li>- when bit 2 of PCOMP = 0 the information element shall not be present;</li> <li>- when bit 2 of PCOMP = 1 the information element shall be present.</li> </ul> <p>NOTE 4: For usage, refer to clause 28.3.3.3.</p> <p>NOTE 5: There may be more than one DCOMP negotiation element if more than one compression mechanism is assigned for a single NSAPI.</p> <p>NOTE 6: The maximum length shall be 128 octets.</p>				

#### 28.4.4.2 SN-ACTIVATE PDP CONTEXT DEMAND

SN-ACTIVATE PDP CONTEXT DEMAND PDU shall contain information elements as defined in table 373.

- Message: SN-ACTIVATE PDP CONTEXT DEMAND PDU
- Response to: -
- Response expected: SN-ACTIVATE PDP CONTEXT ACCEPT PDU
- /SN-ACTIVATE PDP CONTEXT REJECT PDU
- Short description:

**Table 373: SN-ACTIVATE PDP CONTEXT DEMAND PDU contents**

Information element	Length	Type	C/O/M	Remark
SN PDU type	4	1	M	
SNDCP version	4	1	M	
NSAPI	4	1	M	see note 1
Address type identifier in demand	3	1	M	
IP Address IPv4	32		C	see note 2
Packet data MS Type	4	1	M	
PCOMP negotiation	8	1	M	
Number of Van Jacobson compression state slots	8		C	see note 3
Number of compression state slots, TCP	8		C	see note 4
Number of compression state slots, non-TCP	16		C	see note 4
Maximum interval between full headers	8		C	see note 4
Maximum time interval between full headers	8		C	see note 4
Largest header size in octets that may be compressed	8		C	see note 4
Access point name index	16	2	O	see note 5
DCOMP negotiation	varies	3	O	
Protocol configuration options	varies	3	O	see note 6
NOTE 1: The MS shall not use value 0.				
NOTE 2: Shall be conditional on the value of Address Type Identifier in Demand (ATID):				
- when ATID = 0 the information element shall be present;				
- for any other value of the ATID the information element shall not be present.				
NOTE 3: Shall be conditional on the value of bit 1 (LSB) of PCOMP negotiation:				
- when bit 1 of PCOMP = 0 the information element shall not be present;				
- when bit 1 of PCOMP = 1 the information element shall be present.				
NOTE 4: Shall be conditional on the value bit 2 of PCOMP negotiation:				
- when bit 2 of PCOMP = 0 the information element shall not be present;				
- when bit 2 of PCOMP = 1 the information element shall be present.				
NOTE 5: The default value shall be "0000hex".				
NOTE 6: The maximum length shall be 128 octets.				

#### 28.4.4.3 SN-ACTIVATE PDP CONTEXT REJECT

SN-ACTIVATE PDP CONTEXT REJECT PDU shall contain information elements as defined in table 374.

- Message: SN-ACTIVATE PDP CONTEXT REJECT PDU
- Response to: SN-ACTIVATE PDP CONTEXT DEMAND PDU
- Response expected: -
- Short description:

**Table 374: SN-ACTIVATE PDP CONTEXT REJECT PDU contents**

Information element	Length	Type	C/O/M	Remark
SN PDU type	4	1	M	
NSAPI	4	1	M	
Activation reject cause	8	1	M	
Protocol configuration options	varies	3	O	see note
NOTE: The maximum length shall be 128 octets.				



#### 28.4.4.4 SN-DATA

SN-DATA PDU shall contain information elements as defined in table 375.

- Message: SN-DATA PDU
- Response to: -
- Response expected: -
- Short description: SN-DATA PDU is used for acknowledged service.

**Table 375: SN-DATA PDU contents**

Information element	Length	Type	C/O/M	Remark
SN PDU type	4	1	M	
NSAPI	4	1	M	
PCOMP	4	1	M	
DCOMP	4	1	M	
N-PDU	varies	1	M	
NOTE:	The N-PDU length is defined by the length of the lower layer PDU. There shall be no O-bit after the N-PDU.			

#### 28.4.4.5 SN-DATA TRANSMIT REQUEST

SN-DATA TRANSMIT REQUEST PDU shall contain information elements as defined in table 376.

- Message: SN-DATA TRANSMIT REQUEST PDU
- Response to: -
- Response expected: SN-DATA TRANSMIT RESPONSE PDU (when SN-DATA TRANSMIT REQUEST PDU is sent by the MS)
- Short description:

**Table 376: SN-DATA TRANSMIT REQUEST PDU contents**

Information element	Length	Type	C/O/M	Remark
SN PDU type	4	1	M	
NSAPI	4	1	M	
Logical link status	1	1	M	see note 1
Enhanced service	1	1	M	see note 1
Resource request	varies		C	see note 2
SNDCP network endpoint identifier	16	2	O	see note 3
Reserved	20	2	O	see note 4
NOTE 1:	This element has meaning only on uplink. The information element value shall be "0" on downlink in the present document.			
NOTE 2:	For usage refer to clause 28.3.5.2a. Shall be conditional on the value of Enhanced service information element: - when the Enhanced service = 1 the Resource request element shall be present; - when the Enhanced service = 0 the Resource request element shall not be present.			
NOTE 3:	For usage refer to clause 28.3.3.3.			
NOTE 4:	Shall not be used in protocol defined in the present document.			

### 28.4.4.6 SN-DATA TRANSMIT RESPONSE

SN-DATA TRANSMIT RESPONSE PDU shall contain information elements as defined in table 377.

Message: SN-DATA TRANSMIT RESPONSE PDU

Response to: SN-DATA TRANSMIT REQUEST PDU (MS to SwMI), SN-RECONNECT PDU

Response expected: -

Short description:

**Table 377: SN-DATA TRANSMIT RESPONSE PDU contents**

Information element	Length	Type	C/O/M	Remark
SN PDU type	4	1	M	
NSAPI	4	1	M	
Accept/Reject	1	1	M	
Transmit response reject cause	8		C	see note 1
SNDCP network endpoint identifier	16	2	O	see note 2
NOTE 1: Shall be conditional on the value of the Accept/Reject information element: - when the Accept/Reject = 0 the transmit response reject cause information element shall be present; - when the Accept/Reject = 1 the transmit response reject cause information element shall not be present.				
NOTE 2: For usage refer to clause 28.3.3.3.				

### 28.4.4.7 SN-DEACTIVATE PDP CONTEXT DEMAND

SN-DEACTIVATE PDP CONTEXT DEMAND PDU shall contain information elements as defined in table 378.

- Message: SN-DEACTIVATE PDP CONTEXT DEMAND PDU
- Response to: -
- Response expected: SN-DEACTIVATE PDP CONTEXT ACCEPT PDU
- Short description:

**Table 378: SN-DEACTIVATE PDP CONTEXT DEMAND PDU contents**

Information element	Length	Type	C/O/M	Remark
SN PDU type	4	1	M	
Deactivation type	8	1	M	
NSAPI	4		C	see note 1
SNDCP network endpoint identifier	16	2	O	see note 2
Reserved	12	2	O	see note 3
NOTE 1: Shall be conditional on the value of the Deactivation type information element: - when the value of the Deactivation type = 0 the NSAPI information element shall not be present; - when the value of the Deactivation type = 1 the NSAPI information element shall be present; - for all other values of the Deactivation type information element the NSAPI shall be present.				
NOTE 2: For usage, refer to clause 28.3.3.3.				
NOTE 3: Shall not be used in protocol defined in the present document.				

### 28.4.4.8 SN-DEACTIVATE PDP CONTEXT ACCEPT

SN-DEACTIVATE PDP CONTEXT ACCEPT PDU shall contain information elements as defined in table 379.

- Message: SN-DEACTIVATE PDP CONTEXT ACCEPT PDU
- Response to: SN-DEACTIVATE PDP CONTEXT DEMAND PDU
- Response expected: -
- Short description:

**Table 379: SN-DEACTIVATE PDP CONTEXT ACCEPT PDU contents**

Information element	Length	Type	C/O/M	Remark
SN PDU type	4	1	M	
Deactivation type	8	1	M	
NSAPI	4		C	see note 1
SNDCP network endpoint identifier	16	2	O	see note 2
Reserved	11	2	O	see note 3
NOTE 1: Shall be conditional on the value of Deactivation type information element: <ul style="list-style-type: none"> <li>- when the Deactivation Type = 0 the NSAPI information element shall not be present;</li> <li>- when the value of the Deactivation type = 1 the NSAPI information element shall be present;</li> <li>- for all other values of the Deactivation type information element the NSAPI shall be present.</li> </ul>				
NOTE 2: For usage, refer to clause 28.3.3.3.				
NOTE 3: Shall not be used in protocol defined in the present document.				

### 28.4.4.9 SN-END OF DATA

SN-END OF DATA PDU shall contain information elements as defined in table 380.

- Message: SN-END OF DATA PDU
- Response to: -/SN-END OF DATA PDU
- Response expected: -/SN-END OF DATA PDU
- Short description: -

**Table 380: SN-END OF DATA PDU contents**

Information element	Length	Type	C/O/M	Remark
SN PDU type	4	1	M	
Immediate service change	1	1	M	
Reserved	41	2	O	see note
NOTE: Shall not be used in protocol defined in the present document.				

### 28.4.4.10 SN-NOT SUPPORTED

SN-NOT SUPPORTED PDU shall contain information elements as defined in table 380A.

- Message: SN-NOT SUPPORTED PDU
- Response to: - Any individually addressed SN PDU
- Response expected: -
- Short description: This PDU may be sent by the MS or the SwMI to indicate that the received SN PDU or the function indicated in the PDU is not supported by the peer entity.

**Table 380A: SN-NOT SUPPORTED PDU contents**

Information element	Length	Type	C/O/M	Remark
SN PDU type	4	1	M	
Not supported SN PDU type	4	1	M	

#### 28.4.4.11 SN-PAGE REQUEST

SN-PAGE REQUEST PDU shall contain information elements as defined in table 381.

- Message: SN-PAGE REQUEST PDU
- Response to: -
- Response expected: No response or SN-PAGE RESPONSE PDU
- Short description:

**Table 381: SN-PAGE REQUEST PDU contents**

Information element	Length	Type	C/O/M	Remark
SN PDU type	4	1	M	
NSAPI	4	1	M	
Reply requested	1	1	M	
SNDSCP network endpoint identifier	16	2	O	see note
NOTE: For usage, refer to clause 28.3.3.3.				

#### 28.4.4.12 SN-PAGE RESPONSE

SN-PAGE RESPONSE PDU shall contain information elements as defined in table 382.

- Message: SN-PAGE RESPONSE PDU
- Response to: SN-PAGE REQUEST PDU
- Response expected: -
- Short description:

**Table 382: SN-PAGE RESPONSE PDU contents**

Information element	Length	Type	C/O/M	Remark
SN PDU type	4	1	M	
NSAPI	4	1	M	
PD service status	1	1	M	
Logical link status	1	1	M	
Enhanced service	1	1	M	
Resource request	varies		C	see note 1
SNDSCP network endpoint identifier	16	2	O	see note 2
Reserved	18	2	O	see note 3
NOTE 1: For usage, refer to clause 28.3.5.2a. Shall be conditional on the value of Enhanced service information element: - when the Enhanced service = 1 the Resource request element shall be present; - when the Enhanced service = 0 the Resource request element shall not be present.				
NOTE 2: For usage, refer to clause 28.3.3.3.				
NOTE 3: Shall not be used in protocol defined in the present document.				

### 28.4.4.13 SN-RECONNECT

SN-RECONNECT PDU shall contain information elements as defined in table 383.

- Message: SN-RECONNECT PDU
- Response to: -
- Response expected: No response, SN-DATA TRANSMIT RESPONSE PDU or SN-DATA TRANSMIT REQUEST PDU
- Short description:

**Table 383: SN-RECONNECT PDU contents**

Information element	Length	Type	C/O/M	Remark
SN PDU type	4	1	M	
Data to send	1	1	M	
NSAPI	4		C	see note 1
Enhanced service	1	1	M	
Resource request	varies		C	see note 2
SNDCP network endpoint identifier	16	2	O	see note 3
Reserved	19	2	O	see note 4
NOTE 1: Shall be conditional on the value of the Data to Send information element: - when the Data to send = 1 the NSAPI information element shall be present; - when the Data to send = 0 the NSAPI information element shall not be present.				
NOTE 2: For usage, refer to clause 28.3.5.2a. Shall be conditional on the value Enhanced service information element: - when the Enhanced service = 1 the Resource request element shall be present; - when the Enhanced service = 0 the Resource request element shall not be present.				
NOTE 3: For usage, refer to clause 28.3.3.3.				
NOTE 4: Shall not be used in protocol defined in the present document.				

### 28.4.4.14 SN-UNITDATA

SN-UNITDATA PDU shall contain information elements as defined in table 384.

- Message: SN-UNITDATA PDU
- Response to: -
- Response expected: -
- Short description: SN-UNITDATA PDU is used for unacknowledged service.

**Table 384: SN-UNITDATA PDU contents**

Information element	Length	Type	C/O/M	Remark
SN PDU type	4	1	M	
NSAPI	4	1	M	
DCOMP	4	1	M	
N-PDU	varies	1	M	
NOTE: The N-PDU length is defined by the length of the lower layer PDU. There shall be no O-bit after the N-PDU.				

## 28.4.5 SNDCP information elements coding

### 28.4.5.1 Accept/Reject

The Accept/Reject information element shall be encoded as defined in table 385.

**Table 385: Accept/Reject element contents**

Information element	Length	Value	Remark
Accept/Reject	1	0	Request rejected by the SwMI
		1	Request accepted by the SwMI

#### 28.4.5.2 Access point name index

The Access point name index information element shall be encoded as defined in table 385a.

**Table 385a: Access point name index contents**

Information element	Length	Value	Remark
Access point name index	16	any	

#### 28.4.5.3 Activation reject cause

The Activation reject cause information element shall be encoded as defined in table 386.

**Table 386: Activation reject cause element contents**

Information element	Length	Value	Remark
Reject cause	8	0	Any reason
		1	MS not provisioned for Packet Data
		2	IPv4 not supported
		3	IPv6 not supported
		4	IPv4 dynamic address negotiation not supported
		5	IPv6 stateful address autoconfiguration not supported
		6	IPv6 stateless address autoconfiguration not supported
		7	Dynamic address pool empty
		8	Static address not correct
		9	Static address in use
		10	Static address not allowed
		11	Static IP address congestion
		12	TETRA Packet data not supported on this location area
		13	TETRA Packet data not supported on this network.
		14	Temporary rejection
		15	Packet Data MS Type not supported
		16	SNDCP version not supported
		17	Mobile IPv4 not supported
		18	Mobile IPv4 Co-located care of address not supported.
		19	Maximum number of PDP Contexts per ITSI exceeded.
		20	User authentication failed
		21	Activation rejected by external PDN
22	Access point name index not correct		
others		Reserved	

#### 28.4.5.4 Address Type Identifier in Demand

The Address Type Identifier in Demand information element shall be encoded as defined in table 387.

**Table 387: Address Type Identifier in Demand element contents**

Information element	Length	Value	Remark
Address Type Identifier in Demand	3	0	IPv4 Static Address
		1	IPv4 Dynamic Address Negotiation
		2	IPv6
		3	Mobile IPv4 Foreign Agent care of address requested
		4	Mobile IPv4 Co-located care-of address requested
		others	Reserved

#### 28.4.5.5 BSD data compression parameters

The BSD data compression parameters information element shall be encoded as defined in table 387a.

**Table 387a: BSD data compression parameters element contents**

Information element	Length	Type	C/O/M	Remark
BSD compression version	3	1	M	
BSD dictionary size	5	1	M	

#### 28.4.5.6 BSD compression version

The BSD compression version information element shall be encoded as defined in table 387b.

**Table 387b: BSD compression version element contents**

Information element	Length	Value	Remark
BSD compression version	3	0	Reserved
		1	Version 1
		2 to 7	Reserved

#### 28.4.5.7 BSD dictionary size

The BSD dictionary size information element shall be encoded as defined in table 387c.

**Table 387c: BSD dictionary size element contents**

Information element	Length	Value	Remark
BSD dictionary size	5	0 to 8	Reserved
		9 to 16	Length of largest code in bits
		17 to 31	Reserved

#### 28.4.5.8 Data to send

The Data to send information element shall be encoded as defined in table 388.

**Table 388: Data to Send element contents**

Information element	Length	Value	Remark
Data to send	1	0	No data to send
		1	SN-DATA PDU awaiting transmission on uplink

## 28.4.5.9 DCOMP

The DCOMP information element shall be encoded as defined in table 389.

**Table 389: DCOMP element contents**

Information element	Length	Value	Remark
DCOMP	4	0	No compression
		1	ITU-T Recommendation V.42bis [19]
		2	BSD compression
		3	Predictor compression
		4	BSD uncompressible packet
		others	Reserved for further compression algorithms(a list of fixed or negotiated algorithms e.g. pkzip, fax, MPEG)

## 28.4.5.10 DCOMP negotiation

The DCOMP negotiation information element shall be encoded as defined in table 390.

**Table 390: DCOMP negotiation element contents**

Information element	Length	Type	C/O/M	Remark
DCOMP	4	1	M	
Data compression parameters	varies	1	C	see note
NOTE: Shall be conditional on the value of DCOMP: - when the DCOMP = 0 no data compression parameters are present; - for all other DCOMP values the relevant data compression parameters shall be present.				

## 28.4.5.11 Deactivation type

The Deactivation type information element shall be encoded as defined in table 391.

**Table 391: Deactivation type element contents**

Information element	Length	Value	Remark
Deactivation type	8	0	Deactivate all NSAPIs
		1	Deactivate NSAPI given in the PDU
		others	Reserved

**Table 391a: Void**

## 28.4.5.12 Enhanced service

The Enhanced service information element shall be encoded as defined in table 391B.

**Table 391B: Enhanced service element contents**

Information element	Length	Value	Remark
Enhanced service	1	0	Enhanced service not requested
		1	Enhanced service requested



### 28.4.5.13 Immediate service change

The Immediate service change information element shall be encoded in table 391C.

**Table 391C: Immediate service change contents**

Information element	Length	Value	Remark
Immediate service change	1	0	Not indicated
		1	Indicated

### 28.4.5.14 IP address Ipv4

The IP address Ipv4 information element shall be encoded as defined in table 392.

**Table 392: IP address IPv4 element contents**

Information element	Length	Value	Remark
IP address Ipv4	32	any	

### 28.4.5.15 Largest header size in octets that may be compressed

The Largest header size in octets that may be compressed information element shall be encoded as defined in table 392a.

**Table 392a: Largest header size in octets that may be compressed element contents**

Information element	Length	Value	Remark
Largest header in octets that may be compressed	8	0 to 255	The size of the largest header in octets.

### 28.4.5.16 Logical link status

The Logical link status information element shall be encoded as defined in table 392B.

**Table 392B: Logical link status element contents**

Information element	Length	Value	Remark
Logical link status	1	0	Advanced link not connected
		1	Advanced link connected

**Table 392C: Void**

### 28.4.5.17 Maximum interval between full headers

The Maximum interval between full headers indicates the maximum number of compressed non-TCP headers that can be sent between full headers. The information element shall be encoded as defined in table 392D.

**Table 392D: Maximum interval between full headers element contents**

Information element	Length	Value	Remark
Maximum interval between full headers	8	0	There is no limit to the number of consecutive compressed headers.
		1 to 255	Maximum 16 x value consecutive compressed headers.

### 28.4.5.18 Maximum time interval between full headers

The Maximum time interval between full headers indicates the maximum interval between full headers. The information element shall be encoded as defined in table 392E.

**Table 392E: Maximum time interval between full headers element contents**

Information element	Length	Value	Remark
Maximum time interval between full headers	8	0	Infinity.
		1 to 255	Compressed headers may not be sent more than 5 x value s after sending the last full header.

### 28.4.5.19 Maximum transmission unit

The Maximum transmission unit information element shall be encoded as defined in table 393.

**Table 393: Maximum Transmission Unit element contents**

Information element	Length	Value	Remark
Maximum transmission unit	3	0	Reserved
		1	296 octets
		2	576 octets
		3	1 006 octets
		4	1 500 octets
		5	2 002 octets
		6	Reserved
		7	Reserved

### 28.4.5.20 Not supported SN PDU type

The Not supported SN PDU type information element shall be encoded as defined in table 393a.

**Table 393a: Not supported SN PDU type element contents**

Information element	Length	Value	Remark
SN PDU type	4	0	SN-Activate PDP Context Demand SN-Activate PDP Context Accept
		1	SN-Deactivate PDP Context Accept
		2	SN-Deactivate PDP Context Demand
		3	SN-Activate PDP Context Reject
		4	SN-Unitdata
		5	SN-Data
		6	SN-Data Transmit Request
		7	SN-Data Transmit Response
		8	SN-End of data
		9	SN-Reconnect
		10	SN-Page Request (SwMI to MS) SN-Page Response (MS to SwMI)
		Others	Reserved

## 28.4.5.21 N-PDU

The N-PDU information element shall be encoded as defined in table 394.

**Table 394: N-PDU element contents**

Information element	Length	Value	Remark
N-PDU	varies	any	The length of a N-PDU may range from 0 bits up to the Maximum transmission unit size, which is set at context activation.

## 28.4.5.22 NSAPI

The NSAPI information element shall be encoded as defined in table 395.

**Table 395: NSAPI element contents**

Information element	Length	Value	Remark
NSAPI	4	0	Reserved
		1 to 14	Dynamically allocated
		15	Reserved

## 28.4.5.23 Number of compression state slots, TCP

The Number of compression state slots, TCP indicates the maximum value of a context identifier in the space of context identifiers allocated for TCP. The information element shall be encoded as defined in table 395a.

**Table 395a: Number of compression state slots, TCP element contents**

Information element	Length	Value	Remark
Number of compression state slots, TCP	8	0 to 255	The value 0 implies having one context. It is recommended that value 0 is not used.

## 28.4.5.24 Number of compression state slots, non-TCP

The Number of compression state slots, non-TCP indicates the maximum value of a context identifier in the space of context identifiers allocated for non-TCP. The information element shall be encoded as defined in table 395B.

**Table 395B: Number of compression state slots, non-TCP element contents**

Information element	Length	Value	Remark
Number of compression state slots, non-TCP	16	0 to 65 535	The value 0 implies having one context. It is recommended that value 0 is not used.

## 28.4.5.25 Number of VJ compression state slots

The number of VJ compression state slots information element shall be encoded as defined in table 396.

**Table 396**

Information element	Length	Value	Remark
Number of Van Jacobson compression state slots	8	2 to 255	It is recommended that values 0 and 1 are not used.

### 28.4.5.26 Packet data MS Type

The Packet data MS Type information element shall be encoded as defined in table 397.

**Table 397: Packet data MS Type element contents**

Information element	Length	Value	Remark
Packet data MS type	4	0	Type A
		1	Type B
		2	Type C
		3	Type D
		4	Type E
		5	Type F
		others	Reserved

### 28.4.5.27 PCOMP

The PCOMP information element shall be encoded as defined in table 398.

**Table 398: PCOMP element contents**

Information element	Length	Value	Remark
PCOMP	4	0	No compression
		1	Van Jacobson compressed TCP/IP
		2	Van Jacobson non-compressed TCP/IP
		3	FULL_HEADER
		4	COMPRESSED_TCP
		5	COMPRESSED_TCP_NODELTA
		6	COMPRESSED_NON_TCP
		7	COMPRESSED_RTP_8
		8	COMPRESSED_RTP_16
		9	COMPRESSED_UDP_8
		10	COMPRESSED_UDP_16
		11	CONTEXT_STATE
others	For further standardization (a list of fixed or negotiated algorithms e.g. IPv6)		

### 28.4.5.28 PCOMP negotiation

The PCOMP negotiation information element shall be encoded as defined in table 399.

**Table 399: PCOMP negotiation element contents**

Information element	Length	Value	Remark
PCOMP negotiation	8	bit 1 (LSB)	Van Jacobson TCP/IP header compression (IETF RFC 1144 [18])
		bit 2	IP header compression (IETF RFC 2507 [51]) Enable use of PCOMP values: FULL_HEADER, COMPRESSED_TCP, COMPRESSED_TCP_NODELTA, COMPRESSED_NON_TCP, CONTEXT_STATE (see note 1)
		bit 3	Enable use of PCOMP values: COMPRESSED_RTP_8, COMPRESSED_RTP_16, COMPRESSED_UDP_8, COMPRESSED_UDP_16 and CONTEXT_STATE (IETF RFC 2508 [52]) (see note1)(see note 2)
		bit 4	Reserved
		bit 5	Reserved
		bit 6	Reserved
		bit 7	Reserved
		bit 8 (MSB)	Reserved
		NOTE 1: Bit 3 not set - "CONTEXT_STATE" shall only be used to synchronize TCP context identities - clause 10.2 IETF RFC 2507 [51]; bit 3 set - "CONTEXT_STATE" may also be used to synchronize UDP_8 and UDP_16 context identities - clause 3.3.5 IETF RFC 2508 [52].	
NOTE 2: This bit shall be conditional on bit 2 and shall only be set to 1 if bit 2 is also set to 1.			

### 28.4.5.29 PD service status

The PD service status information element shall be encoded as defined in table 400.

**Table 400: PD service status element contents**

Information element	Length	Value	Remark
PD service status	1	0	Temporarily unavailable for PD service
		1	Available for PD service

### 28.4.5.30 PDU priority max

The PDU priority max information element shall be encoded as defined in table 401.

**Table 401: PDU priority element contents**

Information element	Length	Value	Remark
PDU priority	3	0	Lowest PDU priority
		etc.	etc.
		7	Highest PDU priority

### 28.4.5.31 Protocol configuration options

The Protocol configuration options information element shall be encoded as defined in table 402.

**Table 402: Protocol configuration options element contents**

Information element	Length	C/O/M	Value	Remark
Configuration protocol	4	M	0000 <sub>2</sub>	PPP All other values are interpreted as PPP in this version of the protocol
Protocol identity	16	M		see notes 1 and 3
Length of protocol identity contents	8	M		see note 3
Protocol identity contents	varies	M		see notes 2 and 3
<p>NOTE 1: Contains the hexadecimal coding of the configuration protocol identifier as defined in IETF RFC 3232 [24]. Bit 8 of the first octet of the protocol identifier information element shall contain the most significant bit and bit 1 of the second octet of the protocol identifier information element shall contain the least significant bit. At least the following protocol identifiers shall be supported in this version of the protocol:</p> <ul style="list-style-type: none"> <li>- C023H = (PAP); and</li> <li>- C223H (CHAP).</li> </ul> <p>The support of other protocol identifiers is implementation dependent and outside the scope of the present document. If the configuration protocol options list contains a protocol identifier that is not supported by the receiving entity the corresponding unit shall be discarded.</p> <p>NOTE 2: The protocol identifier contents information element of each set corresponds to a "Packet" as defined in IETF RFC 1661 [21] that is stripped off the "Protocol field" and the "Padding" octets (i.e. the protocol identifier contents field is constructed from fields "Code", "Identifier", "Length" and "Data" as described in IETF RFC 1661 [21]). The detailed coding of the protocol identifier contents field is specified in the IETF RFC that is associated with the protocol identifier of that unit.</p> <p>NOTE 3: These information elements shall be repeated as a set for each protocol.</p>				

### 28.4.5.32 READY timer

The READY timer information element shall be encoded as defined in table 403.

**Table 403: READY timer element contents**

Information element	Length	Value	Remark
READY timer	4	0	Reserved
		1	200 ms
		2	500 ms
		3	700 ms
		4	1 second
		5	2 s
		6	3 s
		7	5 s
		8	10 s
		9	20 s
		10	30 s
		11	60 s
		12	120 s
		13	180 s
		14	300 s
15	Reserved		

### 28.4.5.33 Reply requested

The Reply requested information element shall be encoded as defined in table 404.

**Table 404: Reply requested element contents**

Information element	Length	Value	Remark
Reply requested	1	0	SNDCP response not requested
		1	SNDCP response requested

### 28.4.5.34 Resource request

The resource request information element shall be coded as defined in table 404a.

**Table 404a: Resource request element contents**

Information element	Length	C/O/M	Value	Remark
Connection symmetry	1	M	0	Symmetric connection
			1	Asymmetric connection
Data transfer throughput (mean value)	3	M	000 <sub>2</sub>	Network dependent minimum (see note 1)
			001 <sub>2</sub>	1/32 of maximum
			010 <sub>2</sub>	1/16 of maximum
			011 <sub>2</sub>	1/8 of maximum
			100 <sub>2</sub>	1/4 of maximum
			101 <sub>2</sub>	1/2 of maximum
			110 <sub>2</sub>	Reserved
			111 <sub>2</sub>	Maximum
Number of timeslots on uplink or on uplink and downlink	2	M	00 <sub>2</sub>	1 timeslot (see note 2)
			01 <sub>2</sub>	2 timeslots
			10 <sub>2</sub>	3 timeslots
			11 <sub>2</sub>	4 timeslots
Number of timeslots on downlink	2	C	00 <sub>2</sub>	1 timeslot (see note 3)
			01 <sub>2</sub>	2 timeslots
			10 <sub>2</sub>	3 timeslots
			11 <sub>2</sub>	4 timeslots
Full capability on uplink	2	M	00 <sub>2</sub>	1 timeslot (see note 4)
			01 <sub>2</sub>	2 timeslots
			10 <sub>2</sub>	3 timeslots
			11 <sub>2</sub>	4 timeslots
Full capability on downlink	2	M	00 <sub>2</sub>	1 timeslot (see note 4)
			01 <sub>2</sub>	2 timeslots
			10 <sub>2</sub>	3 timeslots
			11 <sub>2</sub>	4 timeslots
NOTE 1: The BS may use a control channel as a general packet data channel, supporting advanced links for many MSs, where each MS may be offering/receiving data packets at a low rate or intermittently. This parameter gives the BS the necessary information for planning its resource allocations.				
NOTE 2: In case of symmetric connection (i.e. Connection symmetry element set to "0") the Number of timeslots on uplink element indicates the number of slots both on uplink and downlink direction.				
NOTE 3: Shall be conditional on the value of the Connection symmetry element. The element is present only for asymmetric connection (i.e. Connection symmetry element set to "1").				
NOTE 4: This element indicates MS's capability to handle physical resources to the indicated direction.				

## 28.4.5.35 RESPONSE\_WAIT timer

The RESPONSE\_WAIT timer information element shall be encoded as defined in table 405.

**Table 405: RESPONSE\_WAIT timer element contents**

Information element	Length	Value	Remark
RESPONSE_WAIT timer	4	0	400 ms
		1	600 ms
		2	800 ms
		3	1 second
		4	2 s
		5	3 s
		6	4 s
		7	5 s
		8	10 s
		9	15 s
		10	20 s
		11	30 s
		12	40 s
		13	50 s
		14	60 s
15	Reserved		

## 28.4.5.36 SNDCP version

The SNDCP version information element shall be encoded as defined in table 406.

**Table 406: SNDCP version element contents**

Information element	Length	Value	Remark
SNDCP version	4	0	Reserved
		1	The first version of the TETRA Packet Data specification
		others	Reserved

## 28.4.5.37 SNDCP network endpoint identifier

The SNDCP network endpoint identifier information element shall be encoded as defined in table 407.

**Table 407: SNDCP endpoint identifier element contents**

Information element	Length	Value	Remark
SNDCP endpoint identifier	16		



## 28.4.5.38 SN PDU type

The PDU type information element shall be encoded as defined in table 408.

Table 408: SN PDU type element contents

Information element	Length	Value	Remark
SN PDU type	4	0	SN-Activate PDP Context Demand SN-Activate PDP Context Accept
		1	SN-Deactivate PDP Context Accept
		2	SN-Deactivate PDP Context Demand
		3	SN-Activate PDP Context Reject
		4	SN-Unitdata
		5	SN-Data
		6	SN-Data Transmit Request
		7	SN-Data Transmit Response
		8	SN-End of data
		9	SN-Reconnect
		10	SN-Page Request (SwMI to MS) SN-Page Response (MS to SwMI)
		11	SN-Not Supported
Others	Reserved		

## 28.4.5.39 STANDBY timer

The STANDBY timer information element shall be encoded as defined in table 409.

Table 409: STANDBY timer element contents

Information element	Length	Value	Remark
STANDBY timer	4	0	Reserved
		1	10 second
		2	30 s
		3	1 minute
		4	5 min
		5	10 min
		6	30 min
		7	1 hour
		8	2 hours
		9	3 hours
		10	6 hours
		11	12 hours
		12	24 hours
		13	48 hours
		14	72 hours
15	Forever		

## 28.4.5.40 SwMI IPv6 Information

The SwMI IPv6 information element shall be encoded as defined in table 410.

Table 410: SwMI IPv6 Information

Information element	Length	C/O/M	Value	Remark
IPv6 Network Prefix	64	M		
Prefix Valid Lifetime	32	M		
On-Link Flag	1	M		
Autonomous Address Configuration	1	M	0	Not Supported
			1	Supported

### 28.4.5.41 SwMI Mobile IPv4 Information

The SwMI Mobile IPv4 information element shall be encoded as defined in table 411.

**Table 411: SwMI Mobile IPv4 Information**

Information element	Length	C/O/M	Value	Remark
FA Care of Address	32	M		
Sequence Number	16	M		
FA Registration Lifetime	16	M		
Register via FA (R)	1	M	0	Registration via FA not required
			1	Registration via FA required
FA Busy (B)	1	M	0	Accepting Registrations
			1	Accepting no Registrations
Home Agent (H)	1	M	0	Offers no HA Services
			1	Offers HA Services
Foreign Agent (F)	1	M	0	Offers no HA Services
			1	Offers HA Services
Minimal Encapsulation (M)	1	M	0	Not Supported
			1	Supported
GRE Encapsulation (G)	1	M	0	Not Supported
			1	Supported
Van Jacobsen Compression (V)	1	M	0	Not Supported
			1	Supported

### 28.4.5.42 Transmit response reject cause

The Transmit response reject cause information element shall be encoded as defined in table 412.

**Table 412: Transmit reject cause element contents**

Information element	Length	Value	Remark
Transmit Response Reject Cause	8	0	Any reason
		1	Unknown NSAPI
		2	System resources not available
		others	Reserved

### 28.4.5.43 Type identifier in accept

The Type identifier in accept information element shall be encoded as defined in table 413.

**Table 413: Type Identifier in Accept element contents**

Information element	Length	Value	Remark
Type identifier in accept	3	0	No address
		1	IPv4 Static Address
		2	IPv4 Dynamic Address
		3 to 7	Reserved

#### 28.4.5.44 Type 3 element identifier

The Type 3 element identifier information element shall be encoded as defined in table 414.

**Table 414: Type 3 element identifier element contents**

Information element	Length	Value	Remark
Type 3 element identifier	4	0	DCOMP negotiation
		1	Protocol configuration options
		others	Reserved

#### 28.4.5.45 V.42bis compression request, P<sub>0</sub>

The ITU-T Recommendation V.42bis [19] compression request, P<sub>0</sub> information element shall be encoded as defined in table 415.

**Table 415: ITU-T Recommendation V.42bis data compression request parameters element contents**

Information element	Length	Value	Remark
V.42bis [19] data compression Request	2	0	compress neither direction
		1	compress initiator-to-responder direction only
		2	compress responder-to-initiator direction only
		3	compress both directions

#### 28.4.5.46 V.42bis data compression parameters

The ITU-T Recommendation V.42bis [19] data compression parameters information element shall be encoded as defined in table 416.

**Table 416: ITU-T Recommendation V.42bis data compression parameters element contents**

Information element	Length	Type	C/O/M	Remark
ITU-T Recommendation V.42bis [19] compression request	2	1	M	
ITU-T Recommendation V.42bis [19] number of codewords	16	1	M	
ITU-T Recommendation V.42bis [19] maximum string length	8	1	M	

#### 28.4.5.47 V.42bis maximum string length, P<sub>2</sub>

The ITU-T Recommendation V.42bis [19] maximum string length, P<sub>2</sub> information element shall be encoded as defined in table 417.

**Table 417: ITU-T Recommendation V.42bis maximum string length element contents**

Information element	Length	Value	Remark
ITU-T Recommendation V.42bis [19] maximum string length, P <sub>2</sub>	8	0-5	Reserved
		6-250	Maximum number of characters in an uncompressed data string that is accepted to be encoded.
		251 to 255	Reserved

### 28.4.5.48 V.42bis number of codewords, $P_1$

The ITU-T Recommendation V.42bis [19] number of codewords,  $P_1$  information element shall be encoded as defined in table 418.

**Table 418: ITU-T Recommendation V.42bis number of codewords element contents**

Information element	Length	Value	Remark
ITU-T Recommendation V.42bis [19] number of codewords, $P_1$	16	0 to 511	Reserved
		512 to 65535	Maximum number of codewords in the compressor dictionary. Suitable default value for TETRA packet data TBD

## 28.5 Timers and constants

### 28.5.1 Timers

#### 28.5.1.1 PDP\_ACTIVATE\_WAIT

PDP\_ACTIVATE\_WAIT timer has a fixed value of 30 s. The timer is valid for MS SNDCCP only.

#### 28.5.1.2 PDP\_DEACTIVATE\_WAIT

PDP\_DEACTIVATE\_WAIT timer has a fixed value of 180 s. The timer is valid for MS SNDCCP only.

#### 28.5.1.3 READY

READY timer value is always given in SN-Activate PDP context accept PDU. The latest received SN-Activate PDP context accept PDU values shall be used.

#### 28.5.1.4 STANDBY

STANDBY timer value is always given in SN-Activate PDP context accept PDU. The latest received SN-Activate PDP context accept PDU values shall be used.

#### 28.5.1.5 Void

#### 28.5.1.6 RESPONSE\_WAIT

RESPONSE\_WAIT timer value is always given in SN-Activate PDP context accept PDU. The latest received SN-Activate PDP context accept PDU values shall be used.

#### 28.5.1.7 SERVICE\_CHANGE

SERVICE\_CHANGE timer has a fixed value of 3 s. The timer is valid for MS SNDCCP only.

### 28.5.2 Constants

RETRY\_ACTIVATION has a fixed value 3 times. The constant is valid for MS SNDCCP only.

---

## 29 SDS-TL service and protocol

The Short Data Service (SDS) as defined in clauses 13 and 14 consists of a pre-coded message service and a user-defined message service. The user-defined message service provides a bearer service for 16 bits, 32 bits, 64 bits or up to 2 047 bits of application-defined data. This bearer service and the underlying protocol ensure reliable delivery of user-defined data over the air interface. However, in order to ensure inter-operability of different applications using SDS service, an additional header information is defined to support Short Data Service Transport Layer (SDS-TL) data transfer service.

This clause defines a protocol layer for the SDS user defined data type 4 (this is carried within the 2 047 bits of application defined data).

This additional protocol layer, hereafter called the SDS Transport Layer (SDS-TL), defines means which enhances the service provided by the layer 3 Short Data Service protocol to provide protocol mechanisms for end-to-end acknowledgement, store and forward and to ensure that applications using this service interpret the user data in the same way. Because of the additional header, this protocol is only for use with SDS type 4. In order to guarantee that the basic SDS user data type-4 service and the SDS-TL data transfer service do not disturb each other a protocol header is also added into the basic SDS user data type-4 service, refer to clauses 13.3 and 29.3.2.1.

This clause specifies:

- the services provided by the SDS-TL;
- the functional requirements for the SDS-TL;
- SDS-TL procedures for specific transmission and reception of SDS user-defined data messages;
- the encoding of the Protocol Data Units (PDUs) defined by SDS-TL.

The SDS-TL protocol provides the following services:

- point-to-point message transfer;
- point-to-multipoint message transfer;
- broadcast message transfer;
- end-to-end acknowledgement of message receipt and consumption by application;
- support for multiple application protocols.

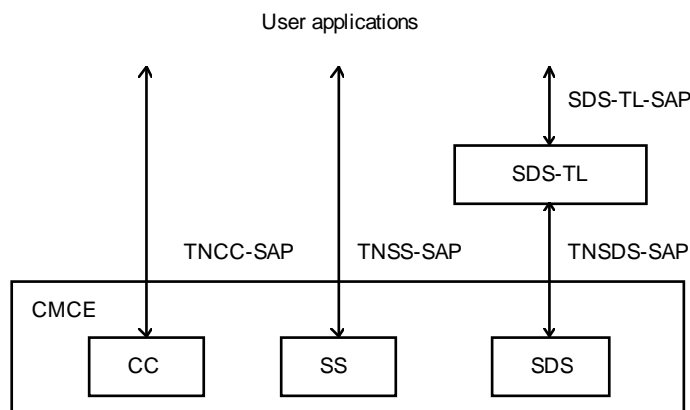
The SDS-TL supports the following types of application which use the SDS bearer service:

- standard applications which use the SDS-TL services;
- non-standard applications which use the SDS-TL services;
- standard applications which do not use the SDS-TL services;
- non-standard applications which do not use the SDS-TL services.

## 29.1 Overview of SDS-TL

### 29.1.1 Protocol architecture

The SDS-TL data transfer service enhances the SDS type 4 data service and in effect replaces SDS type 4 data service to the user application. Figure 216 shows the position of the SDS-TL protocol in the MS/LS protocol stack. The present document does not define a base station protocol architecture or user application SAPs for SDS-TL within the SwMI or in a store and forward entity (service centre).



**Figure 216: SDS-TL position in TETRA protocol stack**

SDS-TL adds a layer of protocol functionality to the SDS user-defined type 4 message protocol which is accessed using the TNSDS-UNITDATA request / indication primitives as defined in clause 13 through the TNSDS-SAP. Note that the pre-coded message service and type 1, 2 and 3 short data message service, also provided by the SDS protocol entity within CMCE, shall still be accessed from a user application using the TNSDS-STATUS and TNSDS-UNITDATA request / indication primitives; there is no other SDS-TL protocol functionality for these services except that the SDS-TL protocol uses a range of STATUS PDUs for acknowledgement purposes.

The present document defines in clause 29.5 standardized protocols, which use services of the TNSDS-SAP via SDS-TL-SAP. Those protocols shall run parallel to each other and other protocols utilising SDS-TL without any interactions.

NOTE 1: In clause 29 terminology "SDS DATA PDU" is used to indicate either U-SDS DATA or D-SDS DATA PDU or an information element of it as defined in clause 14. SDS-TL PDUs refer to the PDUs defined in clause 29 and transported inside in the User-defined data-4 information element of the SDS DATA PDU.

NOTE 2: The term "message" is used in service descriptions when the actual PDU name is not relevant.

NOTE 2: The external subscriber number (information element) may be present both as a part of the SDS DATA PDU and as a part of the SDS-TL PDU inside the forward address information element. The position of the external subscriber number defines its meaning and is indicated when necessary.

## 29.1.2 Addressing

The SDS-TL layer modifies network layer addressing of the SDS, when store and forward capability is used. The sending entity will always indicate at the U/D-SDS DATA PDU the address of the next node. When the next node is a store and forward entity, then the final address will be inside the SDS-TL PDU as a forward address. When the sending entity is the store and forward entity then its address is as the source address in the SDS-DATA PDU and the real source address is in the SDS-TL PDU in the forward address information element. Refer to clause 29.3.1 for further details.

In the protocol model, the external subscriber number (MS-ISDN number) of the sending user is known in the SwMI based on the ITSI of the subscriber and the sending MS/LS does not send it. It is also assumed that the MS/LS user application knows its MS-ISDN number from its ITSI and does not receive it as an additional external subscriber number. MS/LS may use an MS-ISDN number as a destination address in the external subscriber number information element either in the SDS DATA PDU or in the forward address information element and may receive it as a source address in the external subscriber number information element either in the SDS DATA PDU or in the forward address information element.

When MS/LS uses the external subscriber number as a destination address with store and forward entity there is no gateway address inside the forward address information element for the external subscriber or MS-ISDN user and it is assumed that the SwMI or the store and forward server can route the message to a proper gateway or destination.

**NOTE:** The service primitives and protocol PDUs use the same parameter and information element names, which may give a wrong impression of the usage of those parameters and information elements in a store and forward case, refer to relevant see notes in the definition tables.

## 29.1.3 SDS-TL Requirement to SDS and STATUS services

### 29.1.3.1 Requirements to MS/LS

In order to support SDS-TL data transport service the MS/LS shall support SDS type 4 data service at TNSDS-SAP as defined in clause 13 and transportation a range of status values, refer to clause 29.4.2.3. .

### 29.1.3.2 Requirements to the SwMI

In order to support SDS-TL data transport service the SwMI shall support SDS type 4 data and status services as defined in clause 13.

## 29.2 SDS-TL Service Descriptions

The following service descriptions describe the SDS-TL services provided to the higher layers in the MS/LS protocol stack.

### 29.2.1 Services available at the SDS-TL-SAP

The SDS-TL data transfer service shall provide the means whereby SDU are transmitted from a source to a destination in a reliable manner. The source can request confirmation of reception and consumption from the destination. The reception and consumption confirmation can also be transferred in a reliable manner.

The reliable aspect of the transfer can either be achieved transparently through the SwMI or by utilising store and forward capability of the SwMI. The implementation of the store and forward (service centre) entity is outside the scope of the present document.

## 29.2.2 Service primitives at the SDS-TL-SAP

**TLSDS-TRANSFER request:** this primitive shall be used by the SDS-TL entity to send data to a peer entity. Parameters indicate whether reporting is requested.

**TLSDS-TRANSFER indication:** this primitive shall be used by the SDS-TL to pass to the SDS-TL entity data, which has been received from a peer entity.

Table 419 gives parameters for the TLSDS-TRANSFER primitives, when no store and forward entity is used.

**Table 419: Parameters for the TLSDS-TRANSFER primitive without store and forward addressing**

Parameter	Request	Indication
Access priority	O	-
Traffic stealing	O	-
Area selection	O	-
Called party	(see note 1)	(see note 5)
Called party SNA	O (see note 2)	-
Called party SSI	M (see note 2)	M
Called party extension	O (see note 2)	M
External subscriber number (called party)	O	-
Received address type	-	O
Calling party	- (see note 3)	(see note 6)
Calling party SSI	-	M
Calling party extension	-	M
External subscriber number (calling party)	-	O
Protocol identifier	M	M
Delivery report request	M	M
Service selection	M	-
Short form report	-	M
Storage	O	O
Validity period	O	O
Message reference handle	M	-
Message reference	-	M
Time stamp	O (see note 7)	O (see note 7)
User data	O	O
<p>NOTE 1: This parameter shall indicate the destination entity address.</p> <p>NOTE 2: This parameter shall be present as defined by the called party type identifier parameter.</p> <p>NOTE 3: Lower protocol layers will add the calling party identity.</p> <p>NOTE 4: Void.</p> <p>NOTE 5: This parameter value shall indicate "Called party SSI" and "Called party extension".</p> <p>NOTE 6: This parameter value shall indicate "Calling party SSI" and "Calling party extension".</p> <p>NOTE 7: Availability of this parameter is protocol dependent refer to clauses 29.3.2.9 and 29.5.3.3. Normally the SwMI will add the timestamp to the message and the timestamp in the request is to support those cases where that service is not available in the SwMI.</p>		



Table 420 gives parameters for the TLSDS-TRANSFER primitives, when a store and forward entity is used.

**Table 420: Parameters for the TLSDS-TRANSFER primitive with store and forward addressing**

Parameter	Request	Indication
Access priority	O	-
Traffic stealing	O	-
Area selection	O	-
Called party:	(see note 1)	(see note 7)
Called party SNA	C (see note 2)	-
Called party SSI	C (see note 2)	M
Called party extension	C (see note 2)	M
External subscriber number	O (see note 1)	-
Received address type	-	O
Calling party:	- (see note 3)	(see note 9)
Calling party SSI	-	C (see note 8)
Calling party extension	-	C (see note 8)
External subscriber number (calling party)	-	O (see note 9)
Protocol identifier	M	M
Delivery report request	M	M
Service selection	M	-
Short form report	-	M
Storage	M (see note 4)	M (see note 4)
Message reference handle	M	-
Message reference	-	M
Validity period	M	O
Forward address:	(see note 5)	(see note 10)
Forward address SNA	C (see note 6)	
Forward address SSI	C (see note 6)	C (see note 11)
Forward address extension	C (see note 6)	C (see note 11)
External subscriber number	C (see note 6)	C (see note 11)
Time stamp	O (see note 12)	O (see note 12)
User data	O	O
NOTE 1: This parameter shall indicate the store and forward entity address to which the message is going for delivery to the destination.		
NOTE 2: This parameter shall be present as defined by the called party type identifier parameter.		
NOTE 3: Lower protocol layers will add the calling party identity.		
NOTE 4: This parameter shall indicate "storage allowed".		
NOTE 5: This information element shall indicate the final destination entity address.		
NOTE 6: This parameter shall be present as defined by the forward address type identifier parameter.		
NOTE 7: This parameter value shall indicate "Called party SSI" and "Called party extension". This identity shall indicate the destination.		
NOTE 8: This parameter shall be present as defined by the calling party type identifier parameter.		
NOTE 9: This parameter shall indicate the store and forward entity address to which sent the message on behalf of the original source.		
NOTE 10: This parameter shall indicate the original source entity address.		
NOTE 11: This parameter shall be present as defined by the forward address type identifier parameter.		
NOTE 12: Availability of this parameter is protocol dependent refer to clauses 29.3.2.9 and 29.5.3.3. Normally the SwMI will add the timestamp to the message and the timestamp in the request is to support those cases where that service is not available in the SwMI.		

**TLSDS-REPORT request:** this primitive shall be used by the SDS-TL entity to send reports to a peer entity. Parameters indicate whether reporting is requested.

**TLSDS-REPORT indication:** this primitive shall be used by the SDS-TL to pass to the SDS-TL entity reports, which has been received from a peer entity or generated by the SwMI or a service centre.

NOTE: A TLSDS-TNSDS-REPORT indication is used to convey local LLC generated reports about the PDU transfer result.

Table 421 gives parameters for the TLSDS-REPORT primitives, when no store and forward entity is used.

**Table 421: Parameters for the TLSDS-REPORT primitive**

Parameter	Request	Indication
Access priority	O	-
Traffic stealing	O	-
Area selection	O	-
Called party:	(see note 1)	(see note 4)
Called party SNA	C (see note 2)	-
Called party SSI	C (see note 2)	M
Called party extension	C (see notes 2, 7)	M
External subscriber number (called party)	O (see note 7)	-
Calling party:	- (see note 3)	(see notes 5 and 6)
Calling party SSI	-	M
Calling party extension	-	M
External subscriber number (calling party)	-	O (see notes 6 and 7)
Protocol identifier	M (see note 7)	M (see note 7)
Acknowledgement required	M (see note 8)	M (see note 8)
Delivery status	M (see note 8)	M (see note 8)
Message reference handle	-	O (see note 9)
Message reference	M	M
Time stamp	O (see note 10)	O (see note 10)
User data	O (see note 7)	O (see note 7)
NOTE 1: This parameter shall indicate the destination entity address.		
NOTE 2: This parameter shall be present as defined by the called party type identifier parameter.		
NOTE 3: Lower protocol layers will add the calling party identity.		
NOTE 4: This parameter value shall indicate "Called party SSI" and "Called party extension". This parameter shall indicate the destination entity address.		
NOTE 5: This parameter shall value indicate "Calling party SSI" and "Calling party extension".		
NOTE 6: This parameter shall indicate the source entity address.		
NOTE 7: Not applicable for short reports.		
NOTE 8: For short reports these parameters are set to default values locally or may have a limited range of values.		
NOTE 9: This parameter shall be used in the first TLSDS-REPORT indication to a TLSDS-TRANSFER request.		
NOTE 10: Availability of this parameter is protocol dependent refer to clauses 29.3.2.9 and 29.5.3.3. Normally the SwMI will add the timestamp to the message and the timestamp in the request is to support those cases where that service is not available in the SwMI.		

Table 422 gives parameters for the TLSDS-REPORT primitives, when a store and forward entity is used.

**Table 422: Parameters for the TLSDS-REPORT primitive**

Parameter	Request	Indication
Access priority	O	-
Traffic stealing	O	-
Area selection	O	-
Called party	(see note 1)	(see note 4)
Called party SNA	C (see note 2)	-
Called party SSI	C (see note 2)	M
Called party extension	C (see note 2)	M
External subscriber number	O (see note 1)	-
Calling party	- (see note 3)	(see notes 5 and 6)
Calling party SSI	-	M
Calling party extension	-	M
External subscriber number (calling party)	-	O (see note 6)
Protocol identifier	M	M
Acknowledgement required	M	M
Delivery status	M	M
Storage	M (see note 13)	M (see note 13)
Message reference handle	-	O (see note 7)
Message reference	M	M
Validity period	M	O
Forward address:	(see note 8)	(see note 10)
Forward address SNA	C (see note 9)	
Forward address SSI	C (see note 9)	C (see note 11)
Forward address extension	C (see note 9)	C (see note 11)
External subscriber number	C (see note 9)	C (see note 11)
Time stamp	O (see note 12)	O (see note 12)
User data	O	O
NOTE 1: This parameter shall indicate the store and forward entity address which sent the reported message on behalf of the original source.		
NOTE 2: This parameter shall be present as defined by the called party type identifier parameter.		
NOTE 3: Lower protocol layers will add the calling party identity.		
NOTE 4: This parameter value shall indicate "Called party SSI" and "Called party extension". This identity shall indicate the destination.		
NOTE 5: This parameter value shall indicate "Calling party SSI" and "Calling party extension".		
NOTE 6: This parameter shall indicate the store and forward entity address to which the reported message was originally sent.		
NOTE 7: This parameter shall be used in the first TLSDS-REPORT indication to a TLSDS-TRANSFER request.		
NOTE 8: This information element shall indicate the final destination entity address.		
NOTE 9: This parameter shall be present as defined by the forward address type identifier parameter.		
NOTE 10: This parameter shall indicate the original source entity address.		
NOTE 11: This parameter shall be present as defined by the forward address type identifier parameter.		
NOTE 12: Availability of this parameter is protocol dependent refer to clauses 29.3.2.9 and 29.5.3.3. Normally the SwMI will add the timestamp to the message and the timestamp in the request is to support those cases where that service is not available in the SwMI.		
NOTE 13: This parameter shall indicate "storage allowed".		

**TLSDS-ACK request:** this primitive shall be used by the SDS-TL entity to acknowledge reports from a peer entity. The TLSDS-ACK request is used to acknowledge unsolicited reports (consumed message) or reports which may have been stored in the SwMI or at a service centre.

**TLSDS- ACK indication:** this primitive shall be used by the SDS-TL to pass to the SDS-TL entity report acknowledgements, which has been received from a peer entity or generated by the SwMI or a service centre.

Table 423 gives parameters for the TLSDS-ACK primitives, when no store and forward entity is used.

**Table 423: Parameters for the TLSDS-ACK primitive**

Parameter	Request	Indication
Access priority	O	-
Traffic stealing	O	-
Area selection	O	-
Called party	(see note 1)	(see note 4)
Called party SNA	C (see note 2)	-
Called party SSI	C (see note 2)	M
Called party extension	C (see note 2)	M
External subscriber number (called party)	O	-
Calling party	- (see note 3)	(see notes 5, 6)
Calling party SSI	-	M
Calling party extension	-	M
External subscriber number (calling party)	-	O (see note 6)
Protocol identifier	M	M
Delivery status	M	M
Message reference	M	M
NOTE 1: This parameter shall indicate the destination entity address.		
NOTE 2: This parameter shall be present as defined by the called party type identifier parameter.		
NOTE 3: Lower protocol layers will add the calling party identity.		
NOTE 4: This parameter value shall indicate "Called party SSI" and "Called party extension". This parameter shall indicate the destination entity address.		
NOTE 5: This parameter value shall indicate "Calling party SSI" and "Calling party extension".		
NOTE 6: This parameter shall indicate the source entity address.		

Table 424 gives parameters for the TLSDS-ACK primitives, when a store and forward entity is used.

**Table 424: Parameters for the TLSDS-ACK primitive**

Parameter	Request	Indication
Access priority	O	-
Traffic stealing	O	-
Area selection	O	-
Called party:	(see note 1)	(see note 4)
Called party SNA	C (see note 2)	-
Called party SSI	C (see note 2)	M
Called party extension	C (see note 2)	M
External subscriber number	O (see note 1)	-
Calling party:	- (see note 3)	(see notes 5, 6)
Calling party SSI	-	M
Calling party extension	-	M
External subscriber number (calling party)	-	O (see note 6)
Protocol identifier	M	M
Delivery status	M	M
Message reference	M	M
NOTE 1: This parameter shall indicate the store and forward entity address from which the acknowledged report message was received.		
NOTE 2: This parameter shall be present as defined by the called party type identifier parameter.		
NOTE 3: Lower protocol layers will add the calling party identity.		
NOTE 4: This parameter value shall indicate "Called party SSI" and "Called party extension". This identity shall indicate the destination.		
NOTE 5: This parameter value shall indicate "Calling party SSI" and "Calling party extension".		
NOTE 6: This parameter shall indicate the store and forward entity address to which the acknowledged report message was originally sent.		

**TLSDS-TNSDS-REPORT indication:** this primitive shall be used to indicate whether a TLSDS-ACK request, a TLSDS-TRANSFER request, a TLSDS-REPORT request, or a TLSDS-UNITDATA request has been either transmitted successfully or the transmission failure reason (the result of the TNSDS-REPORT). Refer to clause 13.3.2.2 for primitive contents.

**TLSDS-UNITDATA request:** this primitive shall be used to send user defined data-4 to a peer entity, when not using the SDS-TL data transfer services. Refer to clause 13.3.2.2 for primitive contents. The user defined data-4 parameter shall contain the protocol identifier parameter and the actual user data.

**TLSDS-UNITDATA indication:** this primitive shall be used to receive user defined data-4 from a peer entity, when not using the SDS-TL data transfer services. Refer to clause 13.3.2.2 for primitive contents. The user defined data-4 parameter shall contain the protocol identifier parameter and the actual user data.

### 29.2.3 SDS-TL primitives' parameters

Parameter values shall be as defined in this clause and in clause 13.3.3 for the basic SDS.

Acknowledgement required =

no further acknowledgements required for this message; or  
acknowledgement required for this message.

Delivery report request =

no delivery report requested;  
message received report requested;  
message consumed report requested; or  
message received and consumed report requested.

Delivery status =

Refer to clause 29.4.3.2 for further details.

Forward address =

SNA;  
SSI;  
SSI and address extension; or  
external subscriber number.

Message reference =

0 to 255.

Message reference handle =

0 to 255, a local handle to the actual message reference. The mapping between a message reference and a message reference handle is a local issue and outside the scope of the present document.

Protocol identifier =

Protocol which is invoked by the primitive, refer to clause 29.4.3.9.

Service selection =

individual service; or  
group or individual service.

Short form report =

Use of short form report is recommended (during the validity period of the message);

Only standard report allowed.

Storage =

storage not allowed; or

storage allowed.

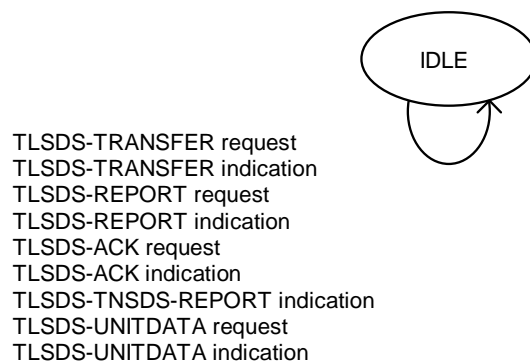
Validity period =

one try, no extended validity period;

10 s to 2 weeks; or

network determined.

## 29.2.4 State description



**Figure 217: State transition diagram**

The IDLE state represents the initial and final state of all the primitive sequences as defined in figure 217. Note that this state transition diagram represents the state transfer of the SDS-TL entity, not the application using SDS-TL. The state diagram of such applications is outside the scope of the present document.

## 29.3 Protocol description

### 29.3.1 Addressing mechanism

When sending an SDS-TL message, the addressing to the final destination is achieved in a number of different ways depending whether a store and forward function is used or not. Following destination addresses are specified in an SDS-TL message from MS/LS to SwMI:

- Called party address (destination or next node) in U-SDS-DATA PDU part;
- External subscriber number (destination or next node) in U-SDS-DATA PDU part;

NOTE 1: The previous addresses can be used for all of the SDS-TL PDUs.

- Forward address (destination) in SDS-TRANSFER PDU part;
- Forward address (original source) in the SDS-REPORT PDU; and
- The used MAC layer address implies the source address.

Following source addresses are specified in an SDS-TL message from SwMI to MS/LS:

- Calling party address (source or previous node) in D-SDS-DATA PDU part;
- External subscriber number (source or previous node) in D-SDS-DATA PDU part;

NOTE 2: The previous addresses can be used for all of the SDS-TL PDUs.

- Forward address (source) in SDS-TRANSFER PDU part;
- Forward address (original destination) in the SDS-REPORT PDU; and
- The used MAC layer address implies the destination address.

The called party address is always present and always indicates the next node address (final destination, store and forward entity or gateway and external subscriber number,).

The external subscriber number is an optional information element that allows sending of up to 24 digits in e.g. an ISDN address. When used in the U-SDS-DATA PDU it amends the called party address (PDU next destination). When used in the D-SDS-DATA PDU it amends the calling party address (PDU latest source). When used in the forward address it is the final destination or original source address.

The forward address is an optional information element that indicates the final destination or original source TETRA address. It may be an SSI, SSI and address extension (TSI) or external subscriber number.

The calling party address is always present and always indicates the previous node address (final destination, store and forward entity or gateway and external subscriber number). In case no forward address is used, the called party address (optionally amended by the external subscriber number) indicates the final destination and the calling party address (optionally amended by the external subscriber number) indicates the source. The use of the addresses in this case is shown in table 425. The addressing of having the final destination / original source in external subscriber number information element of the U-SDS DATA PDU and gateway address in the called party address information element is supported by this addressing scenario.

In case the forward address is used, this address indicates the true destination or original source, and the called or calling party address in the SDS-DATA PDU (optionally amended by the external subscriber number in U-SDS DATA or D-SDS DATA PDU) indicates the next or previous node address. The use of the addresses in this case for MS to MS communication is shown in table 426.

The use of the addresses in the case of communication via a gateway to a user addressed by the external subscriber number is shown in table 427. In that table, user 2 is addressed by the external subscriber number in the forward address field or in the U-SDS-DATA. A target MS (using an MS-ISDN) may be addressed using any of the following combinations:

- via a gateway by indicating the gateway SSI in the called party address and the target in the external subscriber number of the U-SDS-DATA with no forward address (the SSI is the gateway address); or,
- via a gateway by indicating the gateway SSI in the called party address and an external subscriber number in U-SDS-DATA (in which case the external subscriber number identifies some gateway), with the final target in the external subscriber number of the forward address field.

The SwMI may control usage of the forward address by the SYSINFO broadcast, refer to clause 21.4.4.1 table 334a. The SDS-TL addressing method information element values has the meaning:

- "Service centre addressing preferred" defines that the MS shall address the SDS-TL transport service PDUs so it contains the destination of the PDU in the forward address information element and the service centre address in the called party or in the called party and external subscriber number information element of the SDS DATA PDU. Exceptions to that rule are:
  - MS doesn't know the store and forward entity (service centre) address in which case MS may attempt to send the PDU without the forward address directly to the destination. In this scenario, the SwMI may either support the addressing types as defined by "Never use service centre addressing" or the SwMI may reject the message;

NOTE 3: The SwMI may support SDS-TL transport services and use a default store and forward entity or may not support SDS-TL transport services but behave as a transparent SwMI.

- MS is sending the message to a user of another SwMI in which case it may or may not use a forward address. How MS knows whether the other SwMI supports forwards addressing and how it knows the store and forward address of the other SwMI and the behaviour of the other SwMI are outside the scope of the present document.
  - "Never use service centre addressing" defines that the MS shall address the SDS-TL transport service PDUs directly to the destination of the PDU. The message should be addressed directly to the destination, and the forward address shall not be used. If storage is required (a SwMI may support storage without requiring a service centre to be addressed), the storage bit shall set to "storage allowed" and the forward address type shall be set to "no forward address present". Otherwise, the storage bit shall be set to "storage not allowed". Exception to the forward addressing rule is:
    - MS is sending the message to a user of another SwMI in which case it may or may not use a forward address. How MS knows whether the other SwMI supports forwards addressing and how it knows the store and forward address of the other SwMI and the behaviour of the other SwMI are outside the scope of the present document.
- NOTE 4: The broadcast value "never use service centre addressing" normally indicates that the SwMI does not support store and forward functionality.
- "MS choice to use service centre addressing" defines that the MS may select the addressing it applies. The SwMI supports both addressing with and without a service centre. MS should use PDUs without a forward address when it is not using the transport services (store and forward) of the SwMI.

The SYSINFO broadcast information shall control the addressing of the SDS-TRANSFER PDU. The addressing of the SDS-REPORT PDU shall be the same as used in the corresponding SDS-TRANSFER PDU and the SDS-REPORT PDU should use the same store and forward entity (service centre) as used in the original received SDS-REPORT PDU so that also the store and forward entity can update its reporting status information.

**Table 425: MS1 to MS2 transparent**

PDU and hop	Source address in the SDS DATA PDU	Destination address in the SDS DATA PDU	Forward address	Remark
SDS-TRANSFER MS1 → MS2	MS1	MS2	-	No forward address
SDS-REPORT MS2 → MS1 (received)	MS2	MS1	-	No forward address
SDS-REPORT MS2 → MS1 (consumed)	MS2	MS1	-	No forward address
SDS-ACK MS1 → MS2 (consumed-ack)	MS1	MS2	N/A	
NOTE: The destination address can be any addressing type of the SDS-DATA PDU.				



Table 426: MS1 to MS2 using forward address

PDU and hop	Source address in the SDS DATA PDU	Destination address in the SDS DATA PDU	Forward address	Remark
SDS-TRANSFER MS1 → SwMI	MS1	SwMI	MS2, see note 1	Forward address indicates the true destination
SDS-REPORT SwMI → MS1 (delivered / stored)	SwMI	MS1	MS2, see note 3	If present forward address indicates the destination of the original SDS-TRANSFER PDU
SDS-TRANSFER SwMI → MS2	SwMI	MS2	MS1	Forward address indicates the true source
SDS-REPORT MS2 → SwMI (received)	MS2	SwMI	MS1, see note 2	Forward address indicates the original source of the reported SDS-TRANSFER PDU
SDS-REPORT SwMI → MS1 (received)	SwMI	MS1	MS2, see note 3	If present forward address indicates the destination of the original SDS-TRANSFER PDU
SDS-ACK MS1 → SwMI (received-ack)	MS1	SwMI	N/A	
SDS-REPORT MS2 → SwMI (consumed)	MS2	SwMI	MS1, see note 2	Forward address indicates the original source of the reported SDS-TRANSFER PDU
SDS-ACK SwMI → MS2 (consumed-ack)	SwMI	MS2	N/A	
SDS-REPORT SwMI → MS1 (consumed)	SwMI	MS1	MS2, see note 3	If present forward address indicates the destination of the original SDS-TRANSFER PDU
SDS-ACK MS1 → SwMI (consumed-ack)	MS1	SwMI	N/A	
NOTE 1: The use of the Forward address is controlled by the SYSINFO broadcast, refer to clauses 21.4.4.1 table 334a and 29.3.1.				
NOTE 2: The forward address is used because the original SDS-TRANSFER PDU to MS2 contained a forward address.				
NOTE 3: The forward address is optional.				

**Table 427: MS1 to MS2/user 2 using forward address via a gateway**

PDU and hop	Source address in the SDS DATA PDU	Destination address in the SDS DATA PDU	Forward address	Remark
SDS-TRANSFER MS1 → SwMI	MS1	SwMI / SwMI with User 2 in external subscriber number	user 2 / N/A, see note 1	Forward address may indicate the true destination or the true destination may be in the external subscriber number field
SDS-REPORT SwMI → MS1 (delivered / stored)	SwMI	MS1	MS2, see note 3	If present forward address indicates the destination of the original SDS-TRANSFER PDU
SDS-TRANSFER SwMI → MS2/user 2	SwMI	MS2/user 2	MS1	Forward address indicates the true source
SDS-REPORT MS2/user 2 → SwMI (received)	MS2/user 2	SwMI	MS1, see note 2	Forward address indicates the source of the reported SDS-TRANSFER PDU
SDS-REPORT SwMI → MS1 (received)	SwMI	MS1	MS2/user 2, see note 3	If present forward address indicates the destination of the original SDS-TRANSFER PDU
SDS-ACK MS1 → SwMI (received-ack)	MS1	SwMI	N/A	
SDS-REPORT MS2/user 2 → SwMI (consumed)	MS2/user 2	SwMI	MS1, see note 2	Forward address indicates the source of the reported SDS-TRANSFER PDU
SDS-ACK SwMI → MS2/user 2 (consumed-ack)	SwMI	MS2/user 2	N/A	
SDS-REPORT SwMI → MS1 (consumed)	SwMI	MS1	MS2/user 2, see note 3	If present forward address indicates the destination of the original SDS-TRANSFER PDU
SDS-ACK MS1 → SwMI (consumed-ack)	MS1	SwMI	N/A	
NOTE 1: The use of the Forward address is controlled by the SYSINFO broadcast, refer to clauses 21.4.4.1 table 334a and 29.3.1.				
NOTE 2: The forward address is used because the original SDS-TRANSFER PDU to MS2/user 2 gateway contained a forward address. In the case of a TETRA gateway, the PDU exchange is internal to SwMI and may not be explicit.				
NOTE 3: The forward address is optional.				

"MS1", "MS2", and "SwMI" here describe the address of the originating and destination MS, and the address of the store and forward point. The "SwMI" address may comprise a gateway address or a gateway address and an external subscriber address.

## 29.3.2 Description of protocol elements

The clauses 29.3.2.1 to 29.3.2.10 describe the key aspects of the SDS-TL protocol information elements.

### 29.3.2.1 Protocol identifier

Each SDS-DATA type 4 PDU which is sent shall contain a protocol identifier. The protocol identifier shall indicate to the addressed entity application which type of application protocol is using the SDS service. The present document currently defines a number of protocol identifiers to provide e.g. standard text messaging, GPS, WAP, M-DMO and OTAR data application services. A number of reserved protocol identifiers allow additional standard data services to be added in the future. There is also a range of protocol identifiers available for user definition. The value of the protocol identifier determines whether the SDS-TL (data transfer service) protocol elements and the protocol defined in the present document shall be used (see table 439).

### 29.3.2.2 End-to-end acknowledgement types

The main objective of the SDS-TL protocol, as well as providing a mechanism to indicate the type of application using the service, is to provide a means for end-to-end acknowledgement of messages; this mechanism is not provided by the TETRA SDS service as defined in clause 14. SDS-TL provides two types of end-to-end acknowledgement which are distinct from the layer 2 acknowledgement procedures already provided by the LLC. The type of end-to-end acknowledgement which shall apply to a message transfer is set by the originator using the "Delivery report request" information element. These end-to-end acknowledgement types are described below.

- layer 2 acknowledgement only i.e. no end-to-end acknowledgement;
- The LLC provides an acknowledged service for PDUs transferred point-to-point over a single hop i.e. MS to SwMI or SwMI to MS. This acknowledgement confirms to the sender that the layer 3 PDU was received correctly by the receiver. However, the LLC acknowledgement does not imply that the receiving end has yet examined the contents of the PDU. Figure 218 illustrates the layer 2 acknowledgement.

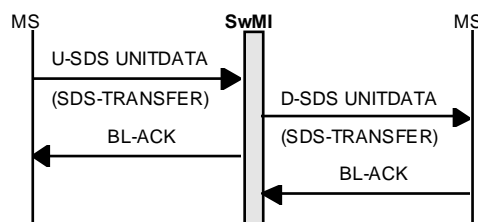


Figure 218: Layer 2 Acknowledgement

- message received
  - The "message received" acknowledgement is sent using the SDS-TL layer to indicate that a message sent by an MS / LS has been successfully received by the destination. This acknowledgement message is an SDS-TL PDU which is generated by the MS / LS after it has decoded the SDS-TL PDU received from the originator. (This is in contrast to a layer 2 acknowledgement which is sent before the incoming PDU has been decoded.) Therefore, this acknowledgement is sent by the destination back to the originator and simply relayed by the SwMI. This type of acknowledgement may be used for point-to-point and point-to-multipoint transfer although care should be used for point-to-multipoint transfer where large group sizes may result in a large amounts of air interface traffic for acknowledgements. Figure 219 illustrates the "message received" end-to-end acknowledgement.

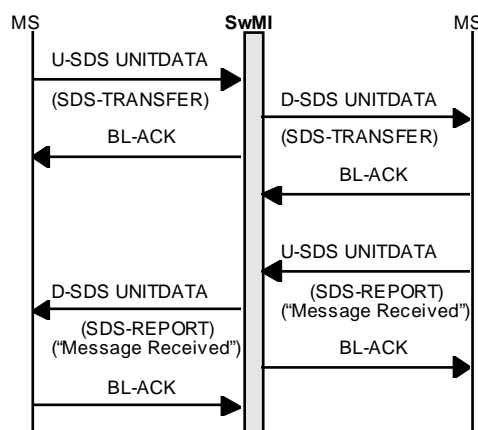
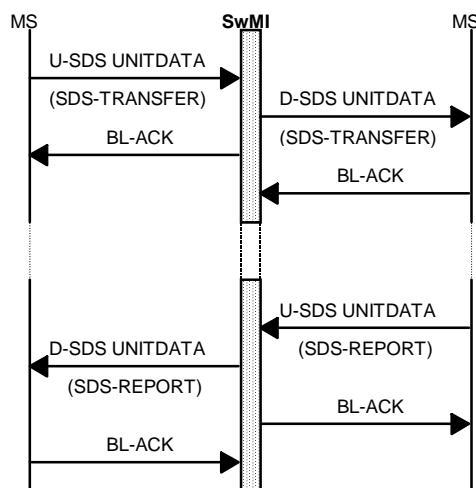


Figure 219: "Message received" end-to-end acknowledgement

- message consumed;
  - The "message consumed" acknowledgement is sent using the SDS-TL layer to indicate that a message sent by an MS / LS has been consumed by the destination. Message consumption occurs after the SDS-TL PDU has been received and decoded by the destination application and refers to the point where the message is actually used by the application. Message consumption is application dependent and is specified in clause 29.3.2.2 for each of the standard applications covered by the present document. Once an application has consumed a message, it may use the SDS-TL protocol to convey this back to the originator. Figure 220 illustrates the "message consumed" end-to-end acknowledgement. Note that this figure does not show any "message received" acknowledgement which may be sent in between the message transfer and the "message consumed" acknowledgement.



**Figure 220: "Message consumed" end-to-end acknowledgement**

For the acknowledgement types "message received" and "message consumed", the SDS-TL protocol shall allow the originator of a message to specify which type of acknowledgement is desired from the destination. An application shall then make this choice depending on the type of data being delivered and whether the transfer is point-to-point or multipoint. SDS-TL simply provides an application with a standardized mechanism to convey these acknowledgement reports.

The criteria of message consumption depends on the application. Message consumption criteria for each of the applications covered by the present document is defined below.

- Text Messaging;
  - Message consumption for the text messaging application shall be when the application displays the text message to the user. Usually, this requires an action by the user to read the message which has been received and stored in the MS / LS.
- GPS;
  - The GPS protocol does not have a clear concept of message consumption. Whether message consumption is applicable or not depends on the application using the protocol.
- Simple Text Messaging;
  - The simple text messaging protocol does not use the SDS-TL data transfer protocol. This means that no end-to-end acknowledgement is available in simple text messaging.
- Simple GPS;
  - The simple GPS protocol does not use the SDS-TL data transfer protocol. This means that no end-to-end acknowledgement is available in simple GPS.
- Other standardized protocols using SDS;

- The other standardized protocols using SDS may or may not use the SDS-TL data transfer protocol. Other SDS-TL protocols may be standardized in the future and the meaning of message consumption defined in the present document. Alternatively, user applications may use SDS-TL where the meaning of message consumption is specific to that application.

### 29.3.2.3 Service selection/short form report

Each uplink SDS-TRANSFER PDU that is sent shall contain a service selection information element. The service selection information element is used to indicate whether the message is allowed to be sent to a group address or not. This is useful in a text messaging application where the user may be allowed to enter the destination address manually. In this case, the sending MS has no way of informing the user that this message will be sent to multiple targets. This could lead to substantial resource waste if, by accident, a message with non-zero delivery report requests is sent to a large group of MSs.

To prevent this, the service selection information element forces the originating user to make an explicit choice that the message is allowed to be sent to a group. The network is then able to reject messages addressed to a group, but with the service selection information element set to "Individual service".

The short form report information element on downlink SDS-TRANSFER PDUs inform the destination user whether it should use or is not allowed to use short form reporting mechanism.

### 29.3.2.4 Storage

Each SDS-TRANSFER PDU that is sent shall contain a "storage" information element. The "storage" information element is used to indicate whether the SwMI is allowed to store the message longer than needed for ordinary processing. If indicated by this information element, the SwMI or a store and forward service point, may store the message for later delivery attempts if the destination is not available.

The criterion for attempting to deliver the message again is outside the scope of the present document.

### 29.3.2.5 Message reference

Each SDS-TL data transfer service PDU that is sent shall contain a message reference information element. This message reference shall be used in the end-to-end acknowledgement back from the destination, or in reports from the SwMI or store and forward entity, to indicate to the originator which message is being acknowledged. The message reference shall also be used in negative acknowledgements.

The originator should choose a different message reference for each new message sent regardless of the destination, if it requests a report. If an acknowledgement is outstanding, regardless of the destination, the corresponding message reference should not be re-used. In the source entity, the validity of the message reference of a message after an extended time after sending the message and expiry of the selected validity period, if any, but without receiving requested reports is outside the scope of the present document.

By following this use of the message reference, the combination of the message reference, and source address (ITSI) shall uniquely identify each message being transported by a TETRA network.

The store and forward entity or SwMI shall not modify the value of the message reference.

NOTE 1: SwMI may not include the forward address into all reports notably error reports in which case the store and forward entity (service centre) address may be the only destination related address in the report. Consequently, the message reference with the store and forward entity address is the only linkage to the sent message and SDS-TRANSFER PDU source entity should choose to use different message reference for each message independently of the destination address.

NOTE 2: In the case of a gateway to another telecommunication network the source or destination address as appropriate is the TETRA address of that gateway.

In the case of short report the message reference may be the only valid identifier of the acknowledgement.

### 29.3.2.6 Validity period

If storage of the message is allowed, each SDS-TRANSFER or SDS-REPORT PDU which is sent by an MS / LS shall contain a "validity period" information element. This information element indicates how long the message should be held by the SwMI in the event that the message cannot be delivered to the destination. A destination MS may be unavailable due to being out of coverage or switched off. If the SwMI holds a message, it should attempt to deliver the message until the validity period expires after which the message is discarded and an error report may be sent back to the originating MS / LS.

Note that the SwMI may not support a storage mechanism or it may limit the duration of the validity period in which case it should return an error report indicating either that the message has not been delivered and that the SwMI will not store the message or that the validity period has terminated.

If the validity period is set to "0" or the element is missing then the SwMI should not store the message for an extended period, if it cannot be delivered.

### 29.3.2.7 Forward address

If storage is allowed, each SDS-TRANSFER which is sent by an MS / LS may contain a "forward address" information element. The MS uses "forward address" information element when the layer 3 destination address points to a network service point (e.g., a service centre) instead of the final destination. The use of such a network service point can be many. The network service point can:

- identify the storing point for a message in a store and forward service;
- identify some other value adding network device.

The "forward address" is somewhat similar to the layer 3 information element "external subscriber number" but is totally independent of it.

When used in the context of providing an addressed storing point for text messages, the forward address is used on the uplink is to inform the network service point of the true destination, and used on the downlink is to inform the destination of the true source. If no forward address is present, the true source and destination are the addresses present in the CMCE SDS PDU information elements except in certain error cases, refer to 29.3.3.

### 29.3.2.8 Data coding scheme

The data coding scheme information element shall indicate to the destination application which type of data coding is being used by the application according to the type of protocol identifier. For example, the text messaging application may use a 7-bit character coding alphabet or a 16-bit alphabet depending on the needs of the particular application. The text coding scheme defines some standard alphabets with some reserved values available for user definition and future standard coding schemes. The GPS coding scheme does the same for GPS.

This information element is present in protocols where data coding scheme is of importance. The information element is thus not part of the layer 4 SDS-TL protocol, but rather a layer 6 addition for specific protocol identifiers (see table 439 and clause 29.5).

### 29.3.2.9 Time stamp

The time stamp information element shall indicate the approximate creation time of the message. The information element is added to a message by the SwMI to allow the destination to evaluate the age of the message. The SwMI decides whether to add the time stamp or not. How this decision is made is outside the scope of the present document, but can e.g. be based on the capabilities of the SwMI or on provisioning arrangements.

In some situations the addition of the time stamp can cause the maximum allowed message length to be exceeded. The SwMI should not add the time stamp in these circumstances, regardless of provisioning arrangements or other aspects.

Note: the time stamps added by the SwMI(s) are not guaranteed to be monotonically increasing.

This information element is present in protocols where store and forward is used and where time stamping is of importance. The information element is thus not part of the layer 4 SDS-TL protocol, but rather a layer 6 addition for specific protocol identifiers (see table 439 and clause 29.5).

### 29.3.2.10 User data length

The length of the "User data" information element (the payload) is derived from the length field in the SDS DATA PDU header. This field indicates the number of bits in the SDS payload, including the (known) length of the SDS-TL header.

For applications, such as simple text messaging, the number of bits in the "User data" information element together with the "Text coding scheme" information element can then be used to derive the number of characters in a message. For example, if the layer 3 SDS type 4 header specifies a length of 86 bits and the coding scheme is 7-bit ASCII, then the "User data" information element contains 70 bits of characters of 7 bits after removal of the SDS-TL header (protocol identifier and text coding scheme), indicating that there are 10 characters present.

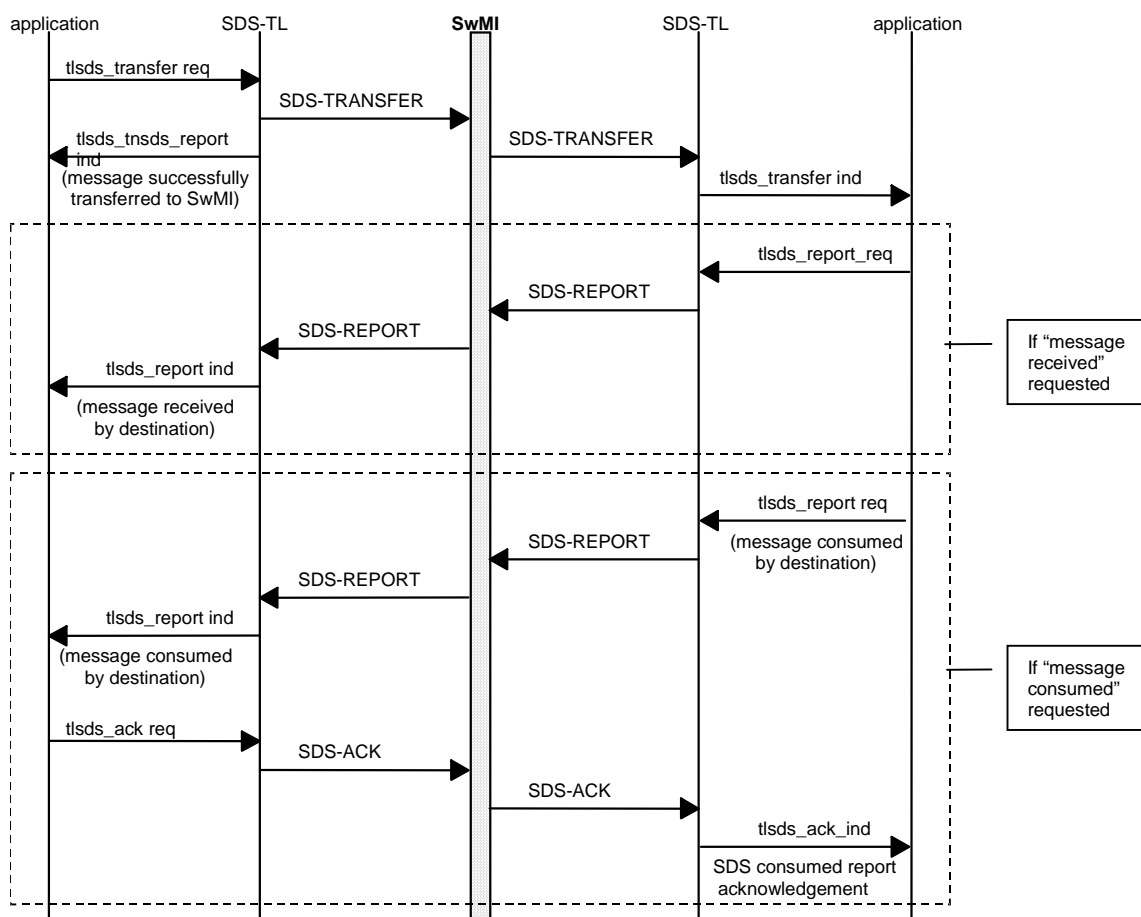
## 29.3.3 Procedures

### 29.3.3.1 General description

Figure 221 shows the protocol sequence for a message transfer from an MS to a destination MS (or group of MSs), where both the received and consumed end-to-end acknowledgements are requested. The SDS-TRANSFER is carried by U/D-SDS-DATA PDUs with an end-to-end acknowledgement being sent by the application of the destination MS on receipt of the message. The acknowledgement is conveyed using SDS-REPORT which is also carried by U/D-SDS-DATA PDUs. On consumption of the message by the application e.g. the user reading a text message, a second end-to-end acknowledgement (SDS-REPORT PDU) is sent by the destination back to the originating MS. This second acknowledgement can almost be considered a second service invocation: the linkage to the original transfer is the message reference and the addresses of the MSs, refer to table 425. Because of this, application may request the SDS-REPORT PDU be end-to-end acknowledged as well. This acknowledgement shall be conveyed using SDS-ACK PDU. Note that if the destination consumes the message before the message received report is sent the destination may only send back the consumed report.

If the end-to-end mechanisms are used, the application should define procedures for handling of retries in case of missing acknowledgements. These procedures are application specific and outside the scope of the present document

The protocol is here used transparently to the SwMI, which only acts as a layer 3 network. This means that part of this protocol sequence can be left out by the application: the SwMI need not to be aware of this. In particular, the SDS-TL protocol allows the application to specify which kind of acknowledgement is requested by the message source. If storage is not allowed, the SwMI should always act transparently.



NOTE: The `tlsds_tnsds` report (message successfully transferred to SwMI) as the first response to the `tlsds` transfer req is an example of lower layer reports (BL-ACK PDU) and is not repeated for all requests.

**Figure 221: SDS message transfer with end-to-end acknowledgement, SwMI transparent**

If the SwMI stores the message for later delivery, the SwMI store and forward entity may inform the originating MS by sending an SDS-REPORT PDU. This is shown in figure 222. This informs the originating MS that the message has been received by the store and forward service: see note that this message should be sent if either the "message received" or "message consumed" delivery reports are requested. On consumption of the message by the application e.g. the user reading a text message, a second end-to-end acknowledgement is sent by the destination back to the originating MS, again through the store and forward service.

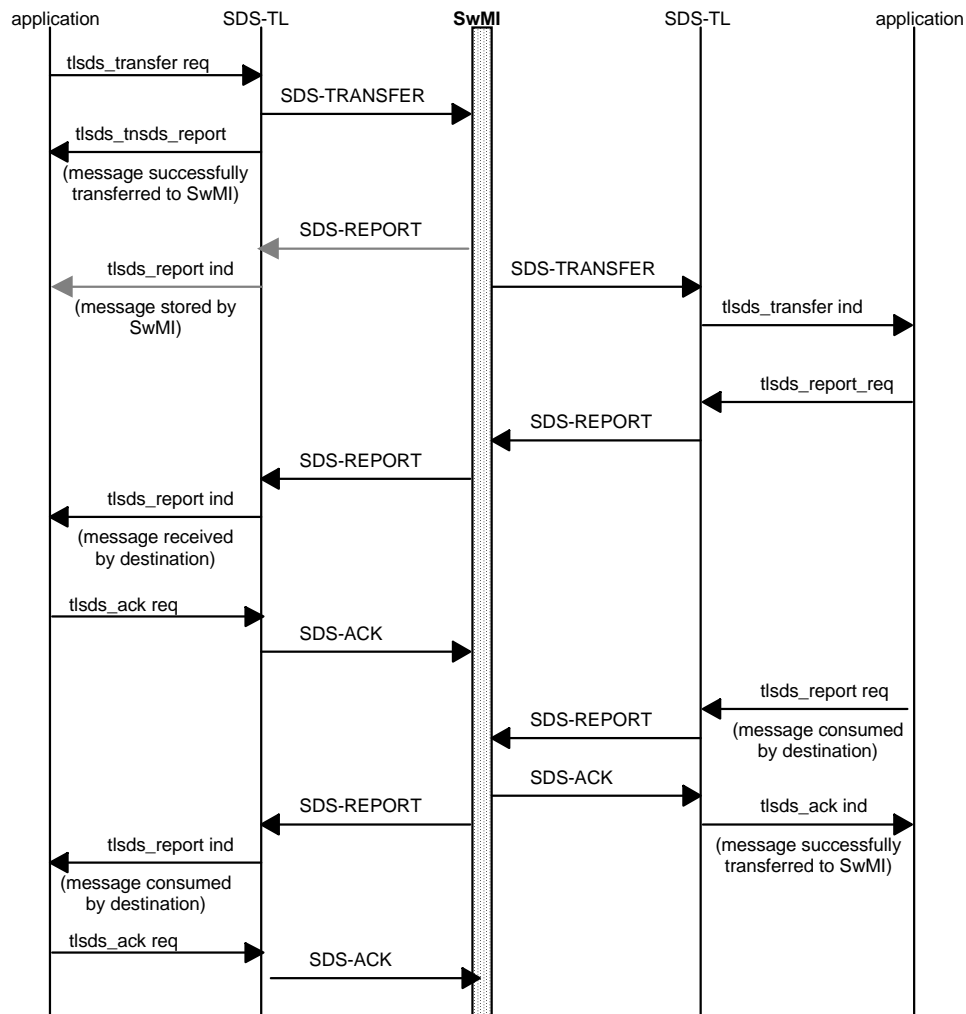
NOTE: In figures 221 to 223 texts in brackets next to service primitives indicate a completion of an action not a service primitive parameter value.

Note that the protocol sequence changes when the SwMI does store and forward. First, the sequence of messages changes because of the "intelligent" part resident in the SwMI. Secondly, one additional layer 4 acknowledgement may be needed: the "message received" acknowledge back to source shall, if requested, be acknowledged. However, even if store and forward is supported in the SwMI and allowed by the message source, the protocol sequence can be the same as in the transparent case: if the SwMI delivers the message immediately, the "message stored by SwMI" may not be sent. Note that the SwMI now plays an active role, and leaving out part of this protocol sequence do require that the SwMI is aware of it.

If the "forward address" information element is used to provide store and forward service via an addressed network service point, the true destination address is only visible inside the initial SDS-TRANSFER PDU on the source (left) side of the SwMI (see figure 222). The same applies for the true source address on the destination (right) side. Seen from the SwMI perspective, the source and the destination will no longer communicate with each other, but both will communicate with the store and forward entity.

When using store and forward the SwMI store and forward entity may choose to modify the SDS-REPORT PDU to the source to get an additional SDS-ACK as shown in figure 222.



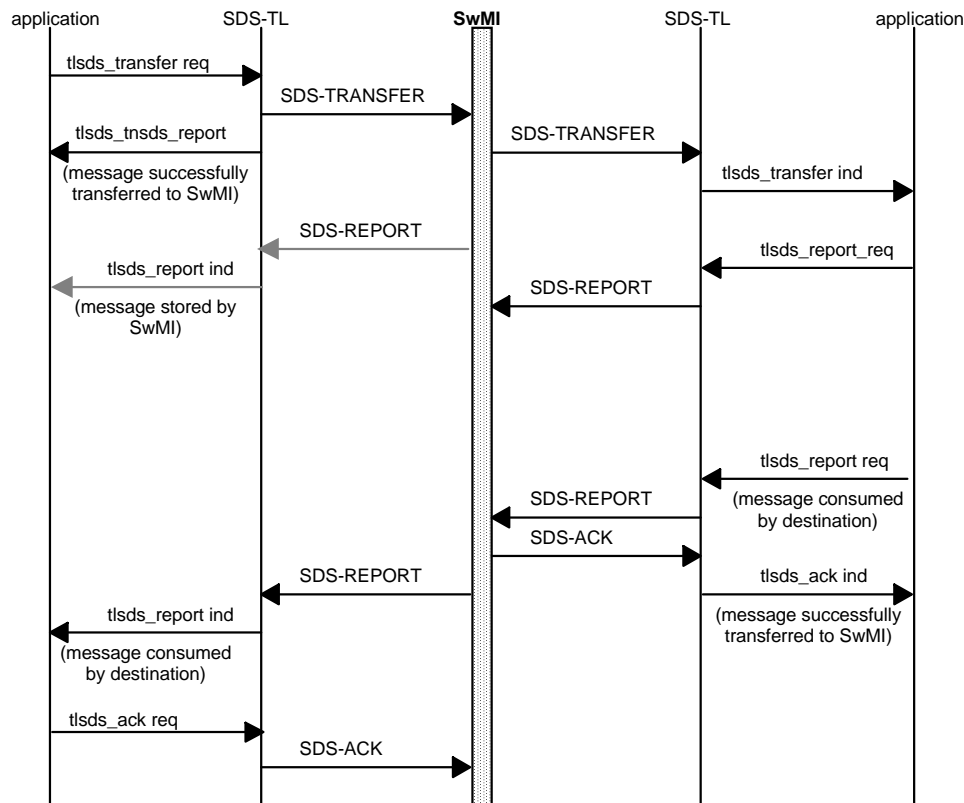


NOTE: The `tlsds_tnsds` report (message successfully transferred to SwMI) as the first response to the `tlsds` transfer req is an example of lower layer reports (BL-ACK PDU) and is not repeated for all requests.

**Figure 222: SDS message transfer with end-to-end acknowledgement, SwMI does store and forward**

When using store and forward and requesting "message consumed" report but not "message received", the SwMI may choose to modify the SDS-TRANSFER PDU to the destination, as shown in figure 223. This will enable the SwMI to stop trying to deliver the message once it has reached the destination application.

NOTE: The SDS-ACK PDU is not an end-to-end acknowledge, but an acknowledge from the next node. This next node may or may not be the final destination.



NOTE: The tlds tnsds report (message successfully transferred to SwMI) as the first response to the tlds transfer req is an example of lower layer reports (BL-ACK PDU) and is not repeated for all requests.

**Figure 223: SDS message transfer with consumed acknowledge, SwMI modifies requested reports**

### 29.3.3.2 MS sending a message

An MS sends a message using SDS-TRANSFER PDU which is conveyed to the SwMI in U-SDS-DATA PDU and to another MS using D-SDS-DATA PDU. SDS procedures for sending U-SDS-DATA PDU and D-SDS-DATA PDU are described in clause 14. The SDS-TRANSFER PDU uses user-defined data type 4 which allows up to 2 047 bits of user data to be transferred (including SDS-TL headers).

SDS-TRANSFER PDU shall contain the information elements defined in clause 29.4.2.4, table 432.

The protocol identifier indicates the user application protocol that is using the short data transfer service.

The message reference shall be set by the SDS-TL entity of the sending party (original source) to identify reports sent back from the destination or next node. The sending user application shall use a local message reference handle in the TLSDS-TRANSFER request primitive and the SDS-TL entity shall allocate the actual message reference and shall inform it the user application in the first report. The sending MS SDS-TL entity shall select a new value to the message reference each time it sends a new message in the SDS-TRANSFER PDU whether to the same destination or to a different destination. The sending MS/LS shall not select a message reference value used in a received SDS-TRANSFER PDU from the same source to which MS/LS is sending a SDS-TRANSFER PDU as long as there is a pending report request to the received SDS-TRANSFER PDU. The combination of the identities of the source address and the message reference shall uniquely identify the sent message.

The short form report does not contain the Protocol identifier information element, and therefore SDS-TL entity shall not allocate the same message reference value for multiple applications in the same originating MS/LS when there is a pending report on that message reference value. The usage of the SDS-SHORT REPORT PDU is application independent.

The delivery report request indicates to the SwMI and the destination for the short message the type of reports which are required. These may be an acknowledgement from the destination when it receives the message or an acknowledgement from the destination when the message is consumed or both. For a text messaging application, message consumption would correspond to the user reading the received text message.

If message storage is allowed the validity period shall inform the SwMI how long the message is valid. The SwMI may use this information to store the message in the situation where the destination is not available. If the message cannot be delivered before the validity period expires, the SwMI shall discard the message and may report back to the sending MS that the message delivery was unsuccessful. The SwMI may modify the validity period for its own purposes when it send the message to the destination.

The destination MS/LS may refer to the message also after the validity period by using the message reference. The message validity time in that sense is application dependent and is outside the scope of the present document.

The SwMI may control whether the destination may use short form report or not by the short form report information element in the SDS-TRANSFER PDU, refer to clause 29.4.3.10.

The SwMI may control addressing type by the broadcast information element SDS-TL addressing method in the SYSINFO PDU, refer to clause 29.3.1.

### 29.3.3.3 MS receiving a message

An incoming message is received as an SDS-TRANSFER PDU which is carried to an MS in D-SDS-DATA PDU. The information elements of SDS-TRANSFER PDU are as described in clause 29.4.2.4, table 432. The validity period information element may have been modified by the SwMI and may use the indicated value when choosing the report type or addressing, refer to clause 29.3.3.4.4.

When an MS SDS-TL entity receives an incoming message, it shall deliver it to the user application or interpret the message according to the protocol identifier and, if present, the data coding scheme. The delivery report request shall indicate to the MS or user application whether or not an acknowledgement for the message needs to sent back to the SwMI. The procedures for sending an acknowledgement as a report are covered in clause 29.3.3.4. The report may also contain user data.

### 29.3.3.4 Sending an acknowledgement from the destination MS/LS

#### 29.3.3.4.1 General

An MS receiving a message shall send an acknowledgement back to the SwMI according to the value of the "Delivery report request" information element. Note that the use of the term, "acknowledgement" in this sub-clause refers to an SDS-TL data transfer report and not to the layer 2 acknowledgements which may also be sent as part of the underlying SDS and LLC transport mechanism which are being used by SDS-TL. Also, the generator of the report should be the final destination: if the final destination is a host located on the PEI, then the report should be generated by the host connected to the PEI.

The SDS-REPORT PDU shall be used to send an acknowledgement back to the sender of the message. The "Message reference" information element shall be set to be equal to the message reference of the original received message to which the acknowledgement refers. The message reference and original source (destination of the SDS-REPORT PDU) address uniquely identifies a message so that the report can be matched to the SDS-TRANSFER PDU, which is acknowledged, in the SwMI. The message reference may be the only matching element to the SDS-TRANSFER PDU, which is acknowledged, in the originator entity as the use of the original destination address is optional. Refer to clause 29.3.1 on addressing and clause 29.3.2.5 on message reference.

Upon receiving an SDS-REPORT PDU, the SwMI should relay this PDU back to the originator of the SDS-TRANSFER PDU without other modification than required for addressing and validity period, which SwMI may modify. For store and forward networks, the SwMI may temporarily shield the originator from negative acknowledgements or modify the report (see clause 29.3.3.6.3); for example, if a memory capacity exceeded delivery status is returned from the target, the store and forward entity may shield this report from the originator and retry sending the message at a later time within the validity period. The validity period in the SDS-REPORT PDU has no meaning to the destination of the SDS-REPORT PDU. The SwMI may use store and forward service, if it is allowed in the SDS-REPORT PDU. Note that, as shown in figures 221 to 223, the application is responsible for sending acknowledgements using the TLSDS-REPORT request primitive in accordance with the parameters of the TLSDS-TRANSFER indication. The SDS-TL layer simply provides a transport mechanism and PDU definition for sending acknowledgements.

End-to-end acknowledgements may be requested for both point-to-point and point-to-multipoint message transfers; in the case of multipoint transfers an acknowledged service should be used with care due to the amount of air interface traffic which could be generated by a large group of MS/LS sending acknowledgements back to the originator. It is recommended that point-to-multipoint transfer does not request end-to-end acknowledgement. In fact, the SwMI may modify a multi-point transfer (by modifying the "Delivery report request" information element to "No delivery report requested" and returning a report to the originator indicating "SDS sent to group, acknowledgements prevented") to prevent the destination MS / LS group sending acknowledgements.

If an acknowledgement is requested for a point-to-multipoint transfer, the SDS message carrying the acknowledgement shall contain the individual address of each destination MS (not the group address) and the message reference of the original SDS-TRANSFER PDU. It is then the responsibility of the originating application to match the acknowledgements to the original sent message using the message reference.

The sender of the SDS-REPORT PDU may request the recipient to send an SDS-ACK PDU to acknowledge the reception of the SDS-REPORT PDU, refer to clauses 29.3.3.5 and 29.3.3.7.

**NOTE:** When the destination MS wishes to receive an SDS-ACK PDU to its SDS-REPORT PDU and the next node is (non-transparent) SwMI, it may have received other SDS-TRANSFER PDU (from another MS/LS) for which it has sent an SDS-REPORT PDU waiting for an SDS-ACK PDU and the message reference values of the SDS-TRANSFER PDUs happen to be the same. This can happen as each MS allocates independently message references to the SDS-TRANSFER PDUs. In the case of conflict the MS may delay the sending of the SDS-REPORT PDU until it receives an SDS-ACK PDU for the previous one.

#### 29.3.3.4.2 Positive acknowledgement from an MS/LS

If the "Delivery report request" information element in the original SDS-TRANSFER PDU indicates the following acknowledgement type:

- no delivery report requested;

then the destination application shall simply consume the message and shall not send any acknowledgement back to the SwMI.

If the "Delivery report request" information element in the original SDS-TRANSFER PDU indicates:

- message receipt report requested;

and the message is received and successfully decoded, then the destination application shall initiate sending of an acknowledgement to the SwMI using the SDS-REPORT PDU. If the SwMI fails to receive this report, it may retry the delivery. The mechanism determining when to retry the delivery is outside the scope of the present document.

When receiving the acknowledgement, the SwMI should relay this back to the original sending MS/LS. In this case the "Delivery status" information element shall have the following value:

- SDS receipt acknowledged by destination.

If the "Delivery report request" information element in the original SDS-TRANSFER PDU indicates:

- message consumed report requested;

and the message is received and successfully decoded, then the destination application shall initiate sending of an acknowledgement to the SwMI using the SDS-REPORT PDU when the message is consumed. Determining when a message is consumed shall depend on the application which is using the SDS-TL protocol and which is indicated by the protocol identifier (see clause 29.4.3.9). In this case the "Delivery status" information element shall have the following value:

- SDS consumed by destination.

The originator may also request both reports.

The SwMI may control addressing type of the SDS-REPORT PDU by the broadcast information element SDS-TL addressing method, refer to clause 29.3.1.

#### 29.3.3.4.3 Negative acknowledgement from an MS/LS

If a destination receives an individually addressed SDS-TL data transfer service PDU and the MS does not support the specific SDS-TL protocol, or the message cannot be delivered to the peer application, or the destination does not support the application, or the destination cannot receive more messages, then the destination shall issue a negative acknowledgement using the SDS-REPORT PDU. Also the peer application may generate some negative acknowledgements. These error situations are indicated with the "Delivery status" information element set to one of the values outlined in table 434 depending on the nature of the error condition (in this table, the MS may return values that indicate a "report source" as "destination").

Note that, if an error occurs when receiving an individually addressed SDS-TL message, the destination shall send a negative acknowledgement regardless of whether or not the originator requested an acknowledgement. If an error occurs when receiving a broadcast or group addressed message, the message shall be silently discarded.

The SwMI may control addressing type by the broadcast information element SDS-TL addressing method, refer to clause 29.3.1.

#### 29.3.3.4.4 Short form acknowledgement

A short form acknowledgement SDS-SHORT REPORT PDU is defined and transferred using SDS STATUS PDUs to provide an alternative to using the SDS-REPORT PDU (when using SSI addressing, the short form acknowledgement will fit into a single random access burst on the air interface). The SDS-SHORT REPORT PDU may be used to send an acknowledgement from a MS/LS, as described in clauses 29.3.3.4.2 and 29.3.3.4.3 instead of SDS-REPORT PDU.

The SDS-SHORT REPORT PDU may be used when the report is a response to SDS-TRANSFER PDU which contains short form report value "Use of short form report recommended during the validity period of the message" and the validity period has not expired, refer to clause 29.4.3.10. In this case, the destination MS/LS may choose between the SDS-SHORT REPORT PDU and the SDS-REPORT PDU in the cases where the report types available in the short form will suffice. In a transparent transfer mode the SDS-SHORT REPORT PDU may be used even though the validity period is not included into the reported SDS-TRANSFER PDU. The implied validity time is application dependent and outside the scope of the present document.

The short form acknowledgement should be treated by the SwMI and MS/LS equivalent to the corresponding full SDS-REPORT PDU. The SwMI may also the SwMI may modify a short report to a standard report for transmission to the original originator of the SDS-TRANSFER which is being reported.

The usage of the SDS-SHORT REPORT PDU is application independent.

The short form report does not contain the Acknowledgement required information element. The implied value of this information element shall be "No further acknowledgements required for this message".

#### 29.3.3.5 Sending an acknowledgement from the source MS/LS

An MS receiving an acknowledgement shall if requested send a delivery report back to the SwMI. Note that the use of the term, "acknowledgement" in this sub-clause refers to an SDS-TL reports and not to the layer 2 acknowledgements which may also be sent as part of the underlying SDS and LLC transport mechanism which are being used by SDS-TL. Also, the generator of the acknowledgement should be the final destination of the report: if the final destination is a host located on the PEI, then the acknowledgement should be generated by the host connected to the PEI.

The SDS-ACK PDU shall, when required, be used to send an acknowledgement back to the sender of the acknowledgement (report). The "Message reference" information element shall be set to be equal to the message reference of the original received message to which the acknowledgement refers. The message reference and source address (of the SDS-ACK PDU) uniquely identifies the message so that the acknowledgement can be matched to the SDS-REPORT PDU in the next node. In the case of transparent SwMI the next node on this protocol point of view is the destination MS/LS.

If the "Delivery report" information element in the SDS-REPORT PDU indicates:

- SDS receipt acknowledged by destination;

and if the "Acknowledgement required" information element indicates that further acknowledgement is needed, then the source application shall initiate sending of an acknowledgement to the SwMI using the SDS-ACK PDU. In this case the "Delivery status" information element shall have the following value:

- SDS receipt report acknowledgement.

If the "Delivery report" information element in the SDS-REPORT PDU indicates:

- SDS consumed by destination;

and if the "Acknowledgement required" information element indicates that further acknowledgement is needed, then the source application shall initiate sending of an acknowledgement to the SwMI using the SDS-ACK PDU. In this case the "Delivery status" information element shall have the following value:

- SDS consumed report acknowledgement.

For all negative "Delivery report" information values in the SDS-REPORT PDU and if the "Acknowledgement required" information element indicates that further acknowledgement is needed, then the source application shall initiate sending of an acknowledgement to the SwMI using the SDS-ACK PDU. In this case the "Delivery status" information element shall have the following value:

- Negative report acknowledgement.

If the requester fails to receive any of these SDS-ACKs, it may retry the delivery of the SDS-REPORT PDU. The mechanism determining when to retry the delivery is outside the scope of the present document.

### 29.3.3.6 Sending an acknowledgement from the SwMI

#### 29.3.3.6.1 General

In most cases, the SwMI is simply a relay for messages and acknowledgements (reports) sent between an originator and destination. An exception to this is the case of an SDS-TRANSFER PDU that cannot be delivered. Note that the use of the term, "acknowledgement" in this sub-clause refers to an SDS-TL report and not to the layer 2 acknowledgements which may also be sent as part of the underlying SDS and LLC transport mechanism which are being used by SDS-TL.

The SDS-REPORT PDU shall be used to send an acknowledgement back to the sender of the message. The "Message reference" information element shall be set to be equal to the message reference of the SDS-TRANSFER PDU to which the acknowledgement refers. The message reference and original source address of the SDS-TRANSFER PDU (i.e. the destination of the SDS-REPORT PDU) uniquely identify a message so that the acknowledgement can be matched to an SDS-TRANSFER PDU in the next node. The message reference may be the only matching element to the SDS-TRANSFER PDU, which is acknowledged, in the originator entity as the use of the original destination address is optional. Refer to clause 29.3.1 on addressing and clause 29.3.2.5 on message reference.

The SDS-ACK PDU shall be used to send an acknowledgement back to the sender of the report, if requested. The "Message reference" information element shall be set to be equal to the message reference of the SDS-REPORT PDU to which the acknowledgement refers. The message reference and source address uniquely identify the message so that the acknowledgement can be matched to the SDS-REPORT PDU.

**NOTE:** In this contents the SwMI is the entity which is addressed in the basic SDS PDU such as a store and forward entity or a service centre.

### 29.3.3.6.2 Positive acknowledgement from the SwMI

If the SwMI or a service centre forward an SDS-TL message to an external network that does not support the SDS-TL services requested by the originator, the SwMI may acknowledge the forwarding of the message. This acknowledgement only acknowledges the fact that the message has been forwarded and is not a guarantee for either delivery or consumption of the message.

In this case the "Delivery report" information element in the SDS-REPORT PDU indicates:

- SDS message forwarded to external network.

The originator will not receive any further acknowledgements for the message.

### 29.3.3.6.3 Negative acknowledgement from the SwMI

If the SwMI receives an SDS-TL message and the message cannot be delivered to the destination or SwMI detects some error condition (for example, source / destination not authorized for SDS or the network is overloaded) or the message transfer fails for some reason, then the SwMI should issue a negative acknowledgement to the originator using the SDS-REPORT PDU. The "Delivery status" information element is set to one of the values outlined in table 434 depending on the nature of the error condition (in this table, the SwMI may return values that indicate a "report source" as "SwMI").

In store and forward networks, once the validity period has expired, the store and forward entity or SwMI should return an SDS-REPORT with "Delivery status" indicating "validity period expired". The store and forward entity or SwMI should not attempt any further deliveries, and the originating MS should not expect to receive any further reports, for a given message transmission, once "validity period" has expired.

Note that, if an error occurs in the message transfer to the destination, the SwMI should send a negative acknowledgement regardless of whether or not the originator requested an acknowledgement.

### 29.3.3.6.4 Temporary negative acknowledgement from the SwMI

If the SwMI receives an SDS-TL message and the message cannot be delivered to the destination for a temporary reason (for example, destination is not immediately reachable or the network is overloaded), then the SwMI should issue a temporary negative acknowledgement to the originator using the SDS-REPORT PDU. The "Delivery status" information element is set to one of the values outlined in table 434 depending on the nature of the error condition.

The "Delivery status" information element value "Message stored by SwMI" may be used instead of a specific value.

On the reception of these reasons MS should expect that the message will be delivered later and should not resend it before a further failure indication.

### 29.3.3.7 Sending an acknowledgement from the SwMI to destination MS/LS

An SwMI receiving a report shall if requested send an acknowledgement back to the MS/LS. Note that the use of the term, "acknowledgement" in this sub-clause refers to an SDS-TL ACK PDU and not to the layer 2 acknowledgements which may also be sent as part of the underlying LLC transport mechanism. For the scenario refer to figures 222 and 223.

The SDS-ACK PDU shall, when required, be used to send an acknowledgement back to the sender of the report. The "Message reference" information element shall be set to be equal to the message reference of the report to which the acknowledgement refers. Only the message reference uniquely identify the message so that the acknowledgement can be matched to the SDS-REPORT PDU in the MS receiving the SDS-ACK PDU. Refer to clause 29.3.1 on addressing and clause 29.3.2.5 on message reference.

If the "Delivery report" information element in the SDS-REPORT PDU indicates:

- SDS receipt acknowledged by destination

and if the "Acknowledgement required" information element indicates that an acknowledgement is needed, then the SwMI shall initiate sending of an acknowledgement to the MS/LS using the SDS-ACK PDU. In this case the "Delivery status" information element shall have the following value:

- SDS receipt report acknowledgement.

If the "Delivery report" information element in the SDS-REPORT PDU indicates:

- SDS consumed by destination;

and if the "Acknowledgement required" information element indicates that an acknowledgement is needed, then the SwMI shall initiate sending of an acknowledgement to the MS/LS using the SDS-ACK PDU. In this case the "Delivery status" information element shall have the following value:

- SDS consumed report acknowledgement.

For all negative "Delivery report" information values in the SDS-REPORT PDU and if the "Acknowledgement required" information element indicates that an acknowledgement is needed, then the SwMI shall initiate sending of an acknowledgement to the SwMI using the SDS-ACK PDU. In this case the "Delivery status" information element shall have the following value:

- Negative report acknowledgement.

If the requester fails to receive any of these SDS-ACKs, it may retry the delivery of the SDS-REPORT PDU. The mechanism determining when to retry the delivery is outside the scope of the present document.

### 29.3.3.8 Using SDS-TL for system broadcast messages

#### 29.3.3.8.1 General

The SwMI may use SDS-TL to generate messages which contain broadcast information for TETRA MS/LS. This service may provide something similar to the GSM cell broadcast service, refer to EN 300 392-5 [31].

#### 29.3.3.8.2 Sending a broadcast message

The SwMI may send a broadcast message at any time using the SDS-TRANSFER PDU and the SDS bearer service. The SwMI may send such a message to the broadcast address (0xFFFFFFFF hexadecimal) or to a group address and it may repeat the message at intervals dependent on the application using this service. The SwMI should indicate the broadcast address (0xFFFFFFFF hexadecimal) as the source address of the message to allow MSs to react on, or ignore system broadcast messages.

When the SwMI sends a broadcast message, it shall set the protocol identifier to indicate the type of system broadcast information. The system broadcast is thus not limited to text messages, but can be used to transmit other kinds of information, e.g. differential GPS information.

The SwMI shall also set the "Delivery report request" information element to indicate that no delivery report is requested since there shall be no acknowledgement associated with this service.

The "Message reference" information element may be used to indicate different system broadcast messages or it may be changed to indicate that the message has changed.

The "User data" field shall be used in the same way as for point-point and point-to-multipoint transfer described in clause 29.3.3.2.

#### 29.3.3.8.3 Receiving a broadcast message

The MS / LS shall attempt to decode the message according to the protocol identifier and data coding scheme indicated in the header. If the message is a text message and the MS / LS is configured to receive system broadcast messages, then the message may be displayed to the user as it is received.



## 29.4 Coding requirements

### 29.4.1 PDU general structure

The PDUs detailed in clauses 29.4.2.1 to 29.4.2.4 and in clause 29.5 are sub-PDUs of SDS type 4, embedded in the "User defined data-4", refer to clause 14.8.52. The first information element within the "User defined data-4" shall be a protocol identifier. This information element shall identify the application using SDS and the protocol used. The applications using protocol identifiers in the range  $10000000_2$  to  $11111111_2$  shall use the PDUs described in this clause. Applications using protocol identifiers in the range from  $00000000_2$  to  $01111111_2$  shall not use the SDS-TL data transport service protocol (see table 439). The PDU descriptions for some of these protocol identifiers are defined in clause 29.5 and the others are outside the scope of the present document.

The general format of the SDS-TL PDU inside the "User defined data-4" information element is defined according to the annex E.

The information elements shall be transmitted in the order specified by the table with the top information element being transmitted first (before interleaving). The content of an information element is represented by a binary value and the most significant bit of that binary value shall be transmitted first (before interleaving).

**Table 428: PDU layout**

Information element	Length	Value	Remark
Protocol identifier	8		Refer clause 29.4.3.9
Type 1 information element (1)	varies		See definitions in annex E
Type 1 information element (2)	varies		See definitions in annex E
...etc.	...etc.		...etc.
Type 1 information element (n)	varies		See definitions in annex E

The SDS-TL PDUs are intended to be byte-aligned for easier handling by the application. The information elements may be a part of a byte or combination of multiple bytes. There shall be no O-bits or P-bits in the SDS-TL PDUs and the SDS-TL PDU shall fill the whole user data type 4 information element in the D-SDS DATA and U-SDS DATA PDUs.

Information element lengths, values and contents are specified in clause 29.4.2.

The information contained in the following PDU description tables corresponds to the following key:

- Length: length of the information element in bits;
- Type: information element type as defined above;
- C/O/M: conditional/optional/mandatory information in the PDU;
- Remark: comment.

### 29.4.2 PDU Descriptions

The PDU described in this clause all have mandatory and conditional information elements. However, it should be seen that the entire SDS-TL is not used for some protocol identifiers but only the protocol identifier, refer to clause 29.4.3.9. The mandatory elements are thus only mandatory in the case where the SDS-TL is used.

#### 29.4.2.1 SDS-ACK

- Response to: SDS-REPORT PDU;
- Response expected: -
- Short description: This PDU shall be used to acknowledge previously received SDS delivery report;
- PDU carrier: U/D-SDS DATA PDU User defined data-4 information element.

Table 429: SDS-ACK PDU contents

Information element	Length	Type	C/O/M	Remark
Protocol identifier	8	1	M	
Message type	4	1	M	
Reserved	4	1	M	see note
Delivery status	8	1	M	
Message reference	8	1	M	
NOTE: This field is inserted to ensure that the following information elements are aligned to octet boundaries. In this edition of the present document the field shall be set to "0000 <sub>2</sub> ".				

### 29.4.2.2 SDS-REPORT

- Response to: - / SDS-TRANSFER PDU
- Response expected: - / SDS-ACK PDU
- Short description: This PDU shall be used to report on the progress of previously received SDS data.
- PDU carrier: U/D-SDS DATA PDU User defined data-4 information element.

Table 430: SDS-REPORT PDU contents

Information element	Length	Type	C/O/M	Remark
Protocol identifier	8	1	M	
Message type	4	1	M	
Acknowledgement required	1	1	M	
Reserved	2	1	M	see note 1
Storage	1	1	M	
Delivery status	8	1	M	
Message reference	8	1	M	see note 2
Validity period	5	1	C	see note 3
Forward address type	3	1	C	see note 3
Forward address short number address	8	1	C	see note 4
Forward address SSI	24	1	C	see note 4
Forward address extension	24	1	C	see note 4
Number of external subscriber number digits	8	1	C	see notes 4 and 5
External subscriber number digit	4	1	C	see note 6
User data	Variable	1	O	see note 7
NOTE 1: This field is inserted to ensure that the following information elements are aligned to octet boundaries. The field shall be set to "00 <sub>2</sub> " by default.				
NOTE 2: The value shall be the same as defined by the original source of the PDU.				
NOTE 3: This information element shall be present in the PDU only when the "Storage" information element indicates storage service.				
NOTE 4: This information element shall be present only when the Forward address type information element is present and indicates an address type that requires presence of the information element.				
NOTE 5: The number of external subscriber number digits shall be between 1 and 24 digits.				
NOTE 6: This information element shall be present only when the number of external subscriber digits information element is present and it shall contain as many digits as defined in that information element. When the Number of external subscriber number digits information element indicates an odd value the last digit of the external subscriber number shall be followed by an additional digit set to "0" and that additional digit shall not be a part of the external subscriber number.				
NOTE 7: This information element is marked to be type 1 and optional on purpose so that there is no O-bit or P-bit before it but the user data length may be zero.				

### 29.4.2.3 SDS-SHORT REPORT

- Response to: - / SDS-TRANSFER PDU;
- Response expected: -;
- Short description: This PDU shall be used to report on the progress of previously received SDS data;
- PDU carrier: U/D-STATUS PDU Pre-coded status information element.

**Table 431: SDS-SHORT REPORT PDU contents**

Information element	Length	Value	Remark
SDS-TL PDU	6	011111 <sub>2</sub>	This status message belongs to the SDS-TL protocol
Short report type	2	any	
Message reference	8	any	The same value as in the corresponding request PDU

NOTE: The short form acknowledgement does not contain the Acknowledgement required information element. The implied value of this information element defaults to "No further acknowledgements required for this message".

### 29.4.2.4 SDS-TRANSFER

- Response to: -;
- Response expected: - / SDS-REPORT;
- Short description: This PDU shall be used to send SDS data;
- PDU carrier: U/D-SDS DATA PDU User defined data-4 information element.

Table 432: SDS-TRANSFER PDU contents

Information element	Length	Type	C/O/M	Remark
Protocol identifier	8	1	M	
Message type	4	1	M	
Delivery report request	2	1	M	
Service selection / Short form report	1	1	M	
Storage	1	1	M	
Message reference	8	1	M	see note 1
Validity period	5	1	C	see note 2
Forward address type	3	1	C	see note 2
Forward address short number address	8	1	C	see note 3
Forward address SSI	24	1	C	see note 3
Forward address extension	24	1	C	see note 3
Number of external subscriber number digits	8	1	C	see notes 3 and 4
External subscriber number digit	4	1	C	Repeatable, see note 5
Dummy digit	4		C	see note 6
User data	Variable	1	M	
NOTE 1: The value shall be defined by the original source of the PDU.				
NOTE 2: This information element shall be present only, when Storage information element indicates storage service.				
NOTE 3: This information element shall be present only, when Forward address type information element is present and indicates address type that requires presence of the information element.				
NOTE 4: The length shall be between 1 and 24, refer to clause 14.8.20.				
NOTE 5: This information element shall be present only, when the number of external subscriber number digits information element is present and it shall be present as many times as defined by the number of external subscriber number digits information element.				
NOTE 6: This information element shall be present only when the Number of external subscriber number digits information element indicates an odd value. When present the Dummy digit shall be set to "0". The Dummy digit shall not be a part of the external subscriber number. For encoding of each digit refer to clause 14.8.20.				

## 29.4.3 Information elements coding

### 29.4.3.1 Acknowledgement required

The Acknowledgement required information element shall indicate as defined in table 433 if an SDS-REPORT PDU needs further acknowledgement by an SDS-ACK PDU. This may be requested by either the originator or by the SwMI or service centre if needed.

Table 433: Acknowledgement required information element contents

Information element	Length	Value	Remark
Acknowledgement required	1	0 <sub>2</sub>	No further acknowledgements required for this message
		1 <sub>2</sub>	Acknowledgement required for this message

## 29.4.3.2 Delivery status

The Delivery status information element in SDS-REPORT and SDS-ACK PDUs shall indicate as defined in table 433 the status of a previously sent SDS-TRANSFER PDU for which a delivery report has been requested. This information element is also used to communicate error information to an MS/LS when SDS data transfer fails. The "Report source" column in the table 434 shall indicate whether the status value can be used in a status report sourced by the SwMI or the destination for the message transfer or both. Note that a status report generated by the destination may be relayed back to the originator by the SwMI but this report is still classified as being sourced by the destination.

Table 434: Delivery status information element contents

Information element	Length	Value	Remark	Report source
Delivery status	8	000XXXXX <sub>2</sub>	<b>SDS data transfer success</b>	-
		00000000 <sub>2</sub>	SDS receipt acknowledged by destination	Destination
		00000001 <sub>2</sub>	SDS receipt report acknowledgement	SwMI/Source
		00000010 <sub>2</sub>	SDS consumed by destination	Destination
		00000011 <sub>2</sub>	SDS consumed report acknowledgement	SwMI/Source
		00000100 <sub>2</sub>	SDS message forwarded to external network	SwMI
		00000101 <sub>2</sub>	SDS sent to group, acknowledgements prevented	SwMI
		00000110 <sub>2</sub> to 00011111 <sub>2</sub>	Reserved	-
		001XXXXX <sub>2</sub>	<b>Temporary error, SwMI still trying to transfer SDS data</b>	-
		00100000 <sub>2</sub>	Congestion, message stored by SwMI	SwMI
		00100001 <sub>2</sub>	message stored by SwMI	SwMI
		00100010 <sub>2</sub>	Destination not reachable, message stored by SwMI	SwMI
		00100011 <sub>2</sub> to 00111111 <sub>2</sub>	Reserved	-
		010XXXXX <sub>2</sub>	<b>SDS data transfer failed, SwMI is not making any more transfer attempts</b>	-
		01000000 <sub>2</sub>	Network overload	SwMI
		01000001 <sub>2</sub>	Service permanently not available on BS	SwMI
		01000010 <sub>2</sub>	Service temporary not available on BS	SwMI
		01000011 <sub>2</sub>	Source is not authorized for SDS	SwMI
		01000100 <sub>2</sub>	Destination is not authorized for SDS	SwMI
		01000101 <sub>2</sub>	Unknown destination, gateway, or service centre address	SwMI
		01000110 <sub>2</sub>	Unknown forward address	SwMI
		01000111 <sub>2</sub>	Group address with individual service	SwMI
		01001000 <sub>2</sub>	Validity period expired, message not received by far end	SwMI
		01001001 <sub>2</sub>	Validity period expired, message not consumed by far end	SwMI
		01001010 <sub>2</sub>	Delivery failed	SwMI
		01001011 <sub>2</sub>	Destination not registered on system	SwMI
		01001100 <sub>2</sub>	Destination queue full	SwMI
		01001101 <sub>2</sub>	Message too long for destination or gateway	SwMI
		01001110 <sub>2</sub>	Destination does not support SDS-TL data transfer service PDUs	SwMI/Destination
		01001111 <sub>2</sub>	Destination host not connected	Destination
		01010000 <sub>2</sub>	Protocol not supported	Destination
		01010001 <sub>2</sub>	Data coding scheme not supported	Destination
01010010 <sub>2</sub>	Destination memory full, message discarded	Destination		

Information element	Length	Value	Remark	Report source
		01010011 <sub>2</sub>	Destination not accepting SDS messages	SwMI
		01010100 <sub>2</sub>	Reserved	-
		01010101 <sub>2</sub>	Reserved	-
		01010110 <sub>2</sub>	Destination address administratively prohibited	SwMI
		01010111 <sub>2</sub>	Can not route to external network	SwMI
		01011000 <sub>2</sub>	Unknown external subscriber number	SwMI
		01011001 <sub>2</sub>	Negative report acknowledgement	Source
		01011010 <sub>2</sub>	Destination not reachable, message delivery failed	SwMI
		01011011 <sub>2</sub> to 01011111 <sub>2</sub>	Reserved	-
		011XXXXX <sub>2</sub>	<b>Flow control messages</b>	-
		01100000 <sub>2</sub>	Destination memory full	Destination
		01100001 <sub>2</sub>	Destination memory available	Destination
		01100010 <sub>2</sub>	Start pending messages	Destination
		01100011 <sub>2</sub>	No pending messages	SwMI
		01100100 <sub>2</sub> to 01111111 <sub>2</sub>	Reserved	-
		100XXXXX <sub>2</sub>	<b>End to end control messages</b>	-
		10000000 <sub>2</sub>	Stop sending	Destination
		10000001 <sub>2</sub>	Start sending	Destination
		10000010 <sub>2</sub> to 10011111 <sub>2</sub>	Available for user application definition, see note	Destination
		101XXXXX <sub>2</sub> to 111XXXXX <sub>2</sub>	Reserved for future use	-
NOTE: These values may be co-ordinated outside the scope of the present document in order to prevent clashed.				

### 29.4.3.3 Delivery report request

The Delivery report request information element shall indicate as defined in table 435 the type of delivery report which is being requested by the sender of SDS-TRANSFER PDU. This delivery report may be generated either by the SwMI or the destination for the message depending on the type of report. Note that this information element is a bitmap to allow multiple combinations of the types of report (end-to-end acknowledgement) to be requested.

**Table 435: Delivery report request information element contents**

Information element	Length	Value	Remark
Delivery report request	2	00 <sub>2</sub>	No delivery report requested
		01 <sub>2</sub>	Message received report requested (see note 1)
		10 <sub>2</sub>	Message consumed report requested (see note 2)
		11 <sub>2</sub>	Message received and consumed report requested
NOTE 1: This delivery report type shall indicate that the sender of the message is requesting a report when the message has been received by the destination.			
NOTE 2: This delivery report type shall indicate that the sender of the message is requesting a report when the message has been consumed by the destination. A message is consumed when the application processes the message. For example, in the case of text messaging, a message is consumed when the user reads the message.			

### 29.4.3.4 Dummy digit

The Dummy digit information element shall fill unused 4 bits in the case of an odd number of digits in the address information element in order to keep octet boundaries. The only applicable value of the digit shall be "0000<sub>2</sub>" and all other values shall be reserved.

### 29.4.3.5 Forward address type

The Forward address type information element shall indicate as defined in table 436 the type of address in the "Forward address" information element.

NOTE: The usage of a short number address as a forward address requires that the SwMI (store and forward entity or service centre) to which MS addresses the U-SDS-DATA PDU supports supplementary service SS-SNA for the sending MS, refer to EN 300 392-10-8 [32], EN 300 392-11-8 [33] and EN 300 392-12-8 [34].

**Table 436: Forward address type information element contents**

Information element	Length	Value	Remark
Forward address type	3	000 <sub>2</sub>	Short Number Address (SNA) (see note 1)
		001 <sub>2</sub>	Short Subscriber Identity (SSI)
		010 <sub>2</sub>	TETRA Subscriber Identity (TSI)
		011 <sub>2</sub>	External subscriber number
		100 <sub>2</sub>	Reserved
		101 <sub>2</sub>	Reserved
		110 <sub>2</sub>	Reserved
		111 <sub>2</sub>	No forward address present (see note 2).
NOTE 1: The short number addressing is applicable only in messages from an MS to SwMI direction.			
NOTE 2: Refer to clause 29.3.1 for usage of this value.			

### 29.4.3.6 Forward address

The Forward address information element, if present, is one of SNA, SSI or TSI as defined in EN 300 392-1 [9], clause 7 or an External subscriber number. The forward address may be used to convey the true source / destination address to a network service point or service user.

### 29.4.3.7 Message reference

The message reference information element shall give as defined in table 437 an integer representation of a reference number of an SDS-TRANSFER PDU submitted to the SwMI by an MS/LS.

**Table 437: Message reference information elements contents**

Information element	Length	Value	Remark
Message reference	8	00000000 <sub>2</sub> to 11111111 <sub>2</sub>	0 to 255

### 29.4.3.8 Message type

The Message type information element shall identify as defined in table 438 the SDS-TL message type being conveyed by the SDS user defined data service.

**Table 438: Message type information element contents**

Information element	Length	Value	Remark
Message type	4	0XXX <sub>2</sub>	Message transfer protocol is defined by SDS-TL
		0000 <sub>2</sub>	SDS-TRANSFER
		0001 <sub>2</sub>	SDS-REPORT
		0010 <sub>2</sub>	SDS-ACK
		0011 <sub>2</sub> to 0111 <sub>2</sub>	Reserved for additional message types
		1XXX <sub>2</sub>	Defined by application (see note)
NOTE: In this case, the format of the SDS user data shall be defined by the application and not necessarily conforming to this transport protocol standard.			

### 29.4.3.9 Protocol identifier

The Protocol identifier information element shall refer to the user application utilising the SDS-TL protocol as defined in table 439.



Table 439: Protocol identifier information element contents

Information element	Length	Value	Remark	Clause
Protocol identifier	8	00000000 <sub>2</sub>	Reserved, see notes 1 and 2	-
		00000001 <sub>2</sub>	OTAK (Over The Air re-Keying for end to end encryption), refer to EN 300 392-7 [11] V2.1.1 clause 7.6 or ES 202 109 [56] clause 4.6, see notes 2 and 3	29.5.1
		00000010 <sub>2</sub>	Simple Text Messaging, see note 2	29.5.2
		00000011 <sub>2</sub>	Simple GPS, see note 2	29.5.5
		00000100 <sub>2</sub>	Wireless Datagram Protocol WAP, see note 2	29.5.8
		00000101 <sub>2</sub>	Wireless Control Message Protocol WCMP, see note 2	29.5.8
		00000110 <sub>2</sub>	M-DMO (Managed DMO), refer to EN 300 396-10 [20], see note 2	29.5.1
		00000111 <sub>2</sub>	PIN authentication, see note 2	29.5.1
		00001000 <sub>2</sub>	End-to-end encrypted message, see notes 2 and 6	-
		00001001 <sub>2</sub>	Simple immediate text messaging, see note 2	29.5.2
		00001010 <sub>2</sub> to 00111111 <sub>2</sub>	Reserved for future standard definition, see note 2	29.5.1
		01000000 <sub>2</sub> to 01111110 <sub>2</sub>	Available for user application definition, see notes 2 and 4	29.5.1
		01111111 <sub>2</sub>	Reserved for extension, see notes 2 and 7	-
		10000000 <sub>2</sub> to 10000001 <sub>2</sub>	Reserved, see note 5	-
		10000010 <sub>2</sub>	Text Messaging, see note 5	29.5.3
		10000011 <sub>2</sub>	GPS, see note 5	29.5.6
		10000100 <sub>2</sub>	Wireless Datagram Protocol WAP, see note 5	29.5.8
		10000101 <sub>2</sub>	Wireless Control Message Protocol WCMP, see note 5	29.5.8
		10000110 <sub>2</sub>	M-DMO (Managed DMO), refer to EN 300 396-10 [20], see note 5	29.5.1
		10000111 <sub>2</sub>	Reserved for future standard definition, see note 5	-
		10001000 <sub>2</sub>	End-to-end encrypted message, see notes 5 and 6	-
		10001001 <sub>2</sub>	Immediate text messaging, see note 5	29.5.3
		10001010 <sub>2</sub> to 10111111 <sub>2</sub>	Reserved for future standard definition, see note 5	-
11000000 <sub>2</sub> to 11111110 <sub>2</sub>	Available for user application definition, see notes 4 and 5	-		
11111111 <sub>2</sub>	Reserved for extension, see notes 5 and 7	-		

NOTE 1: This protocol identifier value should not be used as it is not allocated for a pre-defined application.

NOTE 2: The SDS-TL data transfer service shall not be used for these protocol identifiers, refer to clause 29.4.1.

NOTE 3: In the EN 300 392-7 [11] clause 7.6 or ES 202 109 [56] clause 4.6 the protocol identifier is identified as "SDS type 4 header".

NOTE 4: The assignment of these protocol identifiers will be co-ordinated in order to prevent clashes, refer to annex J.

NOTE 5: The SDS-TL data transfer service shall be used for these protocol identifiers.

NOTE 6: Refer to TETRA MoU SFPG recommendation 07 for information.

NOTE 7: This value shall indicate that the next 8 bits long value is the protocol identifier and the 16 bits replaces the eight bits of the protocol identifier in the PDUs using this extension method.

### 29.4.3.10 Service selection/short form report

The Service selection information element shall indicate as defined in table 440 on the uplink if the message is allowed to be sent to a group address and on the downlink whether a short form report is allowed for this message. If the value of this information element is set to "individual service" when the destination address is a group address, the SwMI may reject the message.

**Table 440: Service selection/ short form report information element contents**

Information element	Length	Value	Remark
Service selection / short form report	1	0 <sub>2</sub>	Uplink: Individual service Downlink: Use of short form report recommended during the validity period of the message
		1 <sub>2</sub>	Uplink: Group or individual service Downlink: Only standard report allowed

### 29.4.3.11 Short report type

The Short report type information element shall indicate the reason for report as defined in table 441.

**Table 441: Short report type information element contents**

Information element	Length	Value	Remark
Short report type	2	00 <sub>2</sub>	Protocol/encoding not supported
		01 <sub>2</sub>	Destination memory full
		10 <sub>2</sub>	Message received
		11 <sub>2</sub>	Message consumed

### 29.4.3.12 Storage

The Storage information element shall indicate as defined in table 442 if the SwMI is allowed to store the message longer than needed for ordinary processing. If storage is allowed, the "Validity period" and "Forward address" information elements are present.

**Table 442: Storage information element contents**

Information element	Length	Value	Remark
Storage	1	0 <sub>2</sub>	Storage not allowed
		1 <sub>2</sub>	Storage allowed

### 29.4.3.13 User data

The User data information element contains the application data which is coded according to the protocol identified by the Protocol identifier and, if present, the data coding scheme information elements.

### 29.4.3.14 Validity period

The Validity period information element shall indicate the length of time after receiving an SDS-TRANSFER PDU that the SwMI should attempt to deliver the message. If this time expires, the SwMI shall stop delivery attempts and may report message failure to the sending MS. The values shall be as defined in table 443. The maximum error of the validity period should be less than 40 %.

**Table 443: Validity period information element contents**

Information element	Length	Value	Remark
Validity period (VP)	5	0	No validity period, see note 1
		1 to 6	VP x 10 s, see note 2
		7 to 10	(VP - 5) x 1 minute, see note 3
		11 to 16	(VP - 10) x 10 min, see note 4
		17 to 21	(VP - 15) x 1 hour, see note 5
		22 to 24	(VP - 20) x 6 hour, see note 6
		25 to 30	(VP - 24) x 2 day, see note 7
		31	Infinite validity period, see note 8
NOTE 1: In this case, the SwMI should attempt to deliver the message. If unsuccessful, the message is dropped.			
NOTE 2: 10 second intervals up to 60 s			
NOTE 3: 1 minute intervals up to 5 min			
NOTE 4: 10 minute intervals up to 1 hour			
NOTE 5: 1 hour intervals up to 6 hours			
NOTE 6: 6 hour intervals up to 24 hours			
NOTE 7: 2 day intervals up to 12 days			
NOTE 8: In this case, the SwMI should attempt to deliver the message until expiry of a network dependant maximum time.			

## 29.5 Protocol specific definitions

This clause defines information elements specific to the some of the standardized protocol identifiers.

### 29.5.1 Standardized protocols using SDS Type 4 without SDS-TL

For TETRA some services use SDS type 4 without SDS-TL data transport service as information carrier. Some of these protocols will be defined in other TETRA standards such as OTAR for the end-to-end encryption key management mechanism.

#### 29.5.1.1 Protocol sequences

These protocols shall not use the SDS-TL acknowledgement and store and forward services. For protocol sequences refer to references in table 439.

#### 29.5.1.2 PDU Description tables

The minimum standardized information element of these "simple" protocols defined in clause 29 is the protocol identifier. For all other aspects refer to the specific protocol as indicated in the table 438. The standardized simple protocol PDUs shall contain in the basic SDS type-4 information element the information elements as defined in table 444 unless more elements are defined in the specific protocol description in this part or the present document, refer to clause 14.8.52.

**Table 444: Standardized "simple" protocol PDU contents**

Information element	Length	Type	C/O/M	Remark
Protocol identifier	8	1	M	Refer to table 439
Protocol information	Variable	1	M	

## 29.5.2 Simple text messaging

The Simple text message protocol is intended to be a very basic text messaging application defined to a degree where interoperability can be expected. Mechanisms how Simple text messages are presented to the user is outside the scope of the present document.

When a mobile terminated text message is indicated to be a Simple immediate text message and the MS has the capability of displaying short messages, the MS shall display the message immediately. Otherwise the protocol for Simple immediate text messaging is the same as in case of normal simple text messaging. If the MS is incapable of displaying Simple immediate text messages, they can be handled as a normal simple text message.

### 29.5.2.1 Protocol sequences

Simple text message protocol does not use any end-to-end acknowledgement or store and forward mechanisms. The only delivery acknowledgement mechanisms offered is the layer 2 acknowledge independently on each hop.

### 29.5.2.2 PDU description tables

Simple text messaging does not use the SDS-TL data transfer service PDUs, but defines a protocol specific field to specify the data format, refer to 29.5.4.1. The basic SDS type-4 information element shall contain elements as defined in clause 29.5.2.3, refer to clause 14.8.52.

### 29.5.2.3 Simple text messaging

- Response to: -
- Response expected: -
- Short description: This PDU shall be used to send simple text messaging SDS data;
- PDU carrier:

**Table 445: Simple text messaging PDU contents**

Information element	Length	Type	C/O/M	Remark
Protocol identifier	8	1	M	Refer to table 439
Reserved	1	1	M	see note 1
Text coding scheme	7	1	M	As defined in table 447
Text	Variable	1	M	see note 2
NOTE 1: This information element is added in order to keep octet boundaries and to align encoding with the text messaging, refer to clause 29.5.3.3 where the timestamp used information element is in the position. The value of this information element shall be set to "0".				
NOTE 2: The text shall be encoded as defined in the text coding scheme information element.				

## 29.5.3 Text messaging using SDS-TL

The text message protocol offers either a store and forward mechanism in the SwMI or acknowledgements (reports) from destination or both as selected by the originating MS/LS. Mechanisms how normal text messages are presented to the user is outside the scope of the present document.

When a mobile terminated text message is indicated to be an Immediate text message and the MS has the capability of displaying short messages, the MS shall display the message immediately. Otherwise the protocol functionality for Immediate text messaging is the same as in case of normal text messaging. If the MS is incapable of displaying Immediate text messages, they can be handled as a normal text message. For Immediate text messages a message consumed report shall be sent only after the user has performed an action that can be taken as an indication that the Immediate text message is read. The related man machine actions are outside the scope of the present document.

### 29.5.3.1 Protocol sequences

The protocol sequences of text messaging shall be the unmodified protocol sequences defined in clause 29.3.3.

### 29.5.3.2 PDU description tables

The text messaging protocol uses the full SDS-TL data transport service protocol. The text messaging protocol defines additional information elements which are transported in the SDS-TRANSFER PDU.

### 29.5.3.3 Text message transfer SDU

The text message transfer is done by use of an SDS-TRANSFER PDU with additional information elements embedded in the user data portion of the SDS-TRANSFER PDU. The SDU part as defined in table 446 shall be the user data in the SDS-TRANSFER PDU, refer to table 432.

**Table 446: Text message transfer SDU contents**

Information element	Length	Type	C/O/M	Remark
Time stamp used	1	1	M	As defined in table 452, see note 1
Text coding scheme	7	1	M	As defined in table 447, see note 1
Time stamp	24	1	C	As defined in table 451, see note 2
Text	Variable	1	M	see note 3
NOTE 1: These two elements can be processed together in order to keep byte alignment.				
NOTE 2: This information element shall be present only, when the Time stamp used indicates the presence of timestamp.				
NOTE 3: The text shall be encoded as defined in the text coding scheme information element.				

### 29.5.3.4 Text message short form acknowledgement

The text messaging may use the SDS-SHORT REPORT PDU as defined in clause 29.4.4.4.

The destination MS/LS can choose between the SDS-SHORT REPORT PDU and the SDS-REPORT PDU in the cases where the report types available in the short form will suffice, refer to clause 29.3.3.4.4.

## 29.5.4 Text messaging information elements

### 29.5.4.1 Text coding scheme

The text coding of the user data in an SDS message shall be specified by the Text coding scheme information element. The text coding schemes defined in the present document are:

- 7-bit alphabet;
- 8-bit alphabets;
- UCS2.

The 7-bit alphabet is identical to the GSM default alphabet, refer to [3] and this is the 7-bit alphabet which shall be used by the TETRA SDS-TL service defined in the present document.

The 8-bit alphabets defined in the present document are a broad range of available alphabets produced by ISO/IEC 8859 [27], supporting character sets for multiple languages.

The UCS2 alphabet is coded according to the 16-bit UCS2 standard produced by ISO, refer to [28]. This alphabet supports an enhanced selection of characters to support non-Latin languages and is set to become the basic coding form for all 16 bit and 32-bit computer systems during 1997. This alphabet is also supported by GSM.

The text coding scheme shall be as defined in table 447.

NOTE: The timestamp used, refer table 451, and the text coding scheme information elements could be processed together in order to keep byte alignment in the protocol.

Table 447: Text coding scheme information element contents

Information element	Length	Value	Remark
Text coding scheme	7	000000 <sub>2</sub>	7-bit alphabet, see clause 29.5.4.3
		000000 <sub>12</sub>	ISO/IEC 8859-1 Latin 1 (8-bit) alphabet [27]
		000001 <sub>2</sub>	ISO/IEC 8859-2 Latin 2 (8-bit) alphabet [27]
		000001 <sub>12</sub>	ISO/IEC 8859-3 Latin 3 (8-bit) alphabet [27]
		000010 <sub>2</sub>	ISO/IEC 8859-4 Latin 4 (8-bit) alphabet [27]
		000010 <sub>12</sub>	ISO/IEC 8859-5 Latin/Cyrillic (8-bit) alphabet [27]
		000011 <sub>2</sub>	ISO/IEC 8859-6 Latin/Arabic (8-bit) alphabet [27]
		000011 <sub>12</sub>	ISO/IEC 8859-7 Latin/Greek (8-bit) alphabet [27]
		000100 <sub>2</sub>	ISO/IEC 8859-8 Latin/Hebrew (8-bit) alphabet [27]
		000100 <sub>12</sub>	ISO/IEC 8859-9 Latin 5 (8-bit) alphabet [27]
		000101 <sub>2</sub>	ISO/IEC 8859-10 Latin 6 (8-bit) alphabet [27]
		000101 <sub>12</sub>	ISO/IEC 8859-13 Latin 7 (8-bit) alphabet [27]
		000110 <sub>2</sub>	ISO/IEC 8859-14 Latin 8 (8-bit) alphabet [27]
		000110 <sub>12</sub>	ISO/IEC 8859-15 Latin 0 (8-bit) alphabet [27]
		000111 <sub>2</sub>	PC code page 437 (United States)
		000111 <sub>12</sub>	PC code page 737 (Greek II)
		001000 <sub>2</sub>	PC code page 850 (Latin I)
		001000 <sub>12</sub>	PC code page 852 (Eastern Europe/Latin II)
		001001 <sub>2</sub>	PC code page 855 (Cyrillic I)
		001001 <sub>12</sub>	PC code page 857 (Turkish)
		001010 <sub>2</sub>	PC code page 860 (Portuguese)
		001010 <sub>12</sub>	PC code page 861 (Icelandic)
		001011 <sub>2</sub>	PC code page 863 (Canadian/French)
		001011 <sub>12</sub>	PC code page 865 (Nordic)
		001100 <sub>2</sub>	PC code page 866 (Russian/Cyrillic II)
		001100 <sub>12</sub>	PC code page 869 (Greek)
		001101 <sub>2</sub>	ISO/IEC 10646-1 [28] UCS2 (16-bit) alphabet
		001101 <sub>12</sub> to 001111 <sub>12</sub>	Reserved
		010000 <sub>2</sub> to 111111 <sub>12</sub>	Available for user application definition, see note.
		NOTE:	

The "7-bit alphabet" shall indicate that the user data is coded using the 7-bit alphabet given in clause 29.5.4.3. When this alphabet is used, the characters of the message are packed into octets so that 285 characters can be transported in 250 bytes of user data. The support of the 7-bit alphabet is optional for MS equipment supporting the SDS-TL service.

Several 8-bit alphabets are listed as well, however, the list is very long and it is unlikely that an MS will support all 8-bit coding schemes. In case the MS receives a message in an unknown alphabet, the MS may reject the message or map the unsupported alphabet to an alphabet supported by the MS.

The UCS2 alphabet indicates that the user data is coded according to the UCS2 [28] coding scheme.

### 29.5.4.2 Character packing

A 7-bit character number  $\alpha$  is represented as shown in table 448.

Table 448: 7-bit character presentation

b7	b6	b5	b4	b3	b2	b1
$\alpha a$	$\alpha b$	$\alpha c$	$\alpha d$	$\alpha e$	$\alpha f$	$\alpha g$

A 7-bit character number  $\alpha$  has bit "a" as the most significant bit "b7" and bit "g" as the least significant bit "b1".

For the 7-bit alphabet, characters shall first be packed into octets according to TS 100 900 [3] and then inserted octet-by-octet into the user data information element. The unused part of the last octet shall be padded by zeros, if needed.

Tables 448a to 448c present examples of the 7-bit character packing into octets, refer to TS 100 900 [3] clause 6.1.2.1.1 for further examples.

**Table 448a: One 7-bit character in one octet**

	Bits number							
	7	6	5	4	3	2	1	0
Octet 1	0	1a	1b	1c	1d	1e	1f	1g

**Table 448b: Two 7-bit characters in two octets**

	Bits number							
	7	6	5	4	3	2	1	0
Octet 1	2g	1a	1b	1c	1d	1e	1f	1g
Octet 2	0	0	2a	2b	2c	2d	2e	2f

**Table 448c: Seven 7-bit characters in seven octets**

	Bits number							
	7	6	5	4	3	2	1	0
Octet 1	2g	1a	1b	1c	1d	1e	1f	1g
Octet 2	3f	3g	2a	2b	2c	2d	2e	2f
Octet 3	4e	4f	4g	3a	3b	3c	3d	3e
Octet 4	5d	5e	5f	5g	4a	4b	4c	4d
Octet 5	6c	6d	6e	6f	6g	5a	5b	5c
Octet 6	7b	7c	7d	7e	7f	7g	6a	6b
Octet 7	0	0	0	0	0	0	0	7a

NOTE: If the last octet contains 7 padding zeros those can be misinterpreted as an "@" character, refer to table 448c. In that case use of Carriage Return character instead of zero padding will prevent presentation of the "@" character.

The octets containing 7-bit characters shall be set into the user data information element as shown in table 449 for the case of four 7-bit characters.

**Table 449: Character packing for 7-bit alphabet**

Bit position	Octet 1								Octet 2							
	n	n-1	n-2	n-3	n-4	n-5	n-6	n-7	n-8	n-9	n-10	n-11	n-12	n-13	n-14	n-15
Character bit	2g	1a	1b	1c	1d	1e	1f	1g	3f	3g	2a	2b	2c	2d	2e	2f
Bit position	Octet 3								Octet 4							
	n-16	n-17	n-18	n-19	n-20	n-21	n-22	n-23	n-24	n-25	n-26	n-27	n-28	n-29	n-30	n-31
Character bit	4e	4f	4g	3a	3b	3c	3d	3e	0	0	0	0	4a	4b	4c	4d

NOTE: In GSM, the LSB of each octet is transmitted first. However, in TETRA, the PDUs are packed such that the MSB of each octet is transmitted first as indicated in tables 449, 449B and 449D.

An 8-bit character number  $\alpha$  is represented as shown in table 449a.

**Table 449a: 8-bit character presentation**

<b>b8</b>	<b>b7</b>	<b>b6</b>	<b>b5</b>	<b>b4</b>	<b>b3</b>	<b>b2</b>	<b>b1</b>
$\alpha a$	$\alpha b$	$\alpha c$	$\alpha d$	$\alpha e$	$\alpha f$	$\alpha g$	$\alpha h$

An 8-bit character number  $\alpha$  has bit "a" as the most significant bit "b8" and bit "h" as the least significant bit "b1".

The 8-bit characters shall be set into the user data information element as shown in table 449B for the case of four 8-bit characters.

**Table 449B: Character packing for 8-bit alphabet**

	Octet 1								Octet 2							
<b>Bit position</b>	<b>n</b>	<b>n-1</b>	<b>n-2</b>	<b>n-3</b>	<b>n-4</b>	<b>n-5</b>	<b>n-6</b>	<b>n-7</b>	<b>n-8</b>	<b>n-9</b>	<b>n-10</b>	<b>n-11</b>	<b>n-12</b>	<b>n-13</b>	<b>n-14</b>	<b>n-15</b>
Character bit	1a	1b	1c	1d	1e	1f	1g	1h	2a	2b	2c	2d	2e	2f	2g	2h
	Octet 3								Octet 4							
<b>Bit position</b>	<b>n-16</b>	<b>n-17</b>	<b>n-18</b>	<b>n-19</b>	<b>n-20</b>	<b>n-21</b>	<b>n-22</b>	<b>n-23</b>	<b>n-24</b>	<b>n-25</b>	<b>n-26</b>	<b>n-27</b>	<b>n-28</b>	<b>n-29</b>	<b>n-30</b>	<b>n-31</b>
Character bit	3a	3b	3c	3d	3e	3f	3g	3h	4a	4b	4c	4d	4e	4f	4g	4h

A 16-bit character number  $\alpha$  is represented as shown in table 449D.

**Table 449C: 16-bit character presentation**

<b>b16</b>	<b>b15</b>	<b>b14</b>	<b>b13</b>	<b>b12</b>	<b>b11</b>	<b>b10</b>	<b>b9</b>	<b>b8</b>	<b>b7</b>	<b>b6</b>	<b>b5</b>	<b>b4</b>	<b>b3</b>	<b>b2</b>	<b>b1</b>
$\alpha a$	$\alpha b$	$\alpha c$	$\alpha d$	$\alpha e$	$\alpha f$	$\alpha g$	$\alpha h$	$\alpha i$	$\alpha j$	$\alpha k$	$\alpha l$	$\alpha m$	$\alpha n$	$\alpha o$	$\alpha p$

A 16-bit character number  $\alpha$  has bit "a" as the most significant bit "b16" and bit "p" as the least significant bit "b1".

The 16-bit characters shall be set into the user data information element as shown in table 449D for the case of two 16-bit characters.



Table 449D: Character packing for 16-bit alphabet

	Octet 1								Octet 2							
Bit position	n	n-1	n-2	n-3	n-4	n-5	n-6	n-7	n-8	n-9	n-10	n-11	n-12	n-13	n-14	n-15
Character bit	1a	1b	1c	1d	1e	1f	1g	1h	1i	1j	1k	1l	1m	1n	1o	1p
	Octet 3								Octet 4							
Bit position	n-16	n-17	n-18	n-19	n-20	n-21	n-22	n-23	n-24	n-25	n-26	n-27	n-28	n-29	n-30	n-31
Character bit	2a	2b	2c	2d	2e	2f	2g	2h	2i	2j	2k	2l	2m	2n	2o	2p

### 29.5.4.3 7-bit alphabet table

The 7-bit alphabet shall be exactly the same as that specified by the GSM standard. This alphabet should be supported by all MSs which support the SDS-TL protocol. Additional alphabets (including UCS2) may also be supported as options.

The 7-bit alphabet shall be as shown in table 450.

Table 450: Alphabet table for GSM 7-bit alphabet

					b7	0	0	0	0	1	1	1	1
					b6	0	0	1	1	0	0	1	1
					b5	0	1	0	1	0	1	0	1
b4	b3	b2	b1		0	1	2	3	4	5	6	7	
0	0	0	0	0	@	Δ	SP	0	i	P	¿	p	
0	0	0	1	1	£	_	!	1	A	Q	a	q	
0	0	1	0	2	\$	Φ	"	2	B	R	b	r	
0	0	1	1	3	¥	Γ	#	3	C	S	c	s	
0	1	0	0	4	è	Λ	α	4	D	T	d	t	
0	1	0	1	5	é	Ω	%	5	E	U	e	u	
0	1	1	0	6	ù	Π	and	6	F	V	f	v	
0	1	1	1	7	ì	Ψ	'	7	G	W	g	w	
1	0	0	0	8	ò	Σ	(	8	H	X	h	x	
1	0	0	1	9	Ç	Θ	)	9	I	Y	i	y	
1	0	1	0	10	LF	Ξ	*	:	J	Z	j	z	
1	0	1	1	11	Ø	1)	+	;	K	Å	k	å	
1	1	0	0	12	ø	Æ	,	<	L	Ö	l	ö	
1	1	0	1	13	CR	æ	-	=	M	Ñ	m	ñ	
1	1	1	0	14	À	ß	.	>	N	Ü	n	ü	
1	1	1	1	15	â	É	/	?	O	Ş	o	à	

The following rules shall apply to the use of this alphabet:

- Control characters shall have the following meaning:

Code Meaning;

LF Line Feed: Any characters following LF which are to be displayed shall be presented as the next line of the text message, commencing with the first character position;

CR Carriage Return: Any characters following CR which are to be displayed shall be presented as the current line of the text message, commencing with the first character position;

SP Space Character.

- If these characters are to be displayed within a message, each character shall be taken in turn and be placed in the next available space from left to right and from top to bottom.

### 29.5.4.4 Time stamp

The Time stamp information element shall indicate as defined in table 451 the (approximate) creation time of the message. The information element is added to a message by the SwMI to allow the destination to evaluate the age of the message.

**Table 451: Time stamp information element contents**

Information element	Length	Type	C/O/M	Remark
Reserved	4	1	M	see note
Month	4	1	M	1 to 12
Day	5	1	M	1 to 31
Hour	5	1	M	0 to 23
Minute	6	1	M	0 to 59
NOTE:	This field is inserted to ensure that the following information elements are aligned to octet boundaries and so ease processing by the application. In the present document the field shall be set to "0000 <sub>2</sub> ".			

### 29.5.4.5 Timestamp used

The Timestamp used information element shall indicate as defined in table 452 if a timestamp is used in the PDU.

**Table 452: Timestamp used information element contents**

Information element	Length	Value	Remark
Timestamp used	1	0 <sub>2</sub>	Timestamp not present
		1 <sub>2</sub>	Timestamp present

## 29.5.5 Simple GPS

The Simple GPS protocol is intended to be a very basic GPS application, which does not require any transport mechanism to ensure delivery.

### 29.5.5.1 Protocol sequences

Simple GPS does not use any end-to-end acknowledgement (reporting) signalling. The only delivery mechanisms offered is the layer 2 acknowledge.

### 29.5.5.2 PDU description tables

Simple GPS does not use the SDS-TL data transfer service PDUs, but defines a protocol specific field to specify the data format, refer to clause 29.5.7. The basic SDS type-4 information element shall contain elements as defined in clause 29.5.5.3.

### 29.5.5.3 Simple GPS unitdata

- Response to: -
- Response expected: -
- Short description: This PDU shall be used to send GPS SDS data

**Table 453: Simple GPS PDU contents**

Information element	Length	Type	C/O/M	Remark
Protocol identifier	8	1	M	Value 00000011 <sub>2</sub>
GPS coding scheme	8	1	M	As defined in table 455
GPS data	Variable	1	M	

## 29.5.6 GPS using SDS-TL data transfer services

This GPS protocol set offers end-to-end acknowledgement and/or store and forward in the SwMI.

### 29.5.6.1 Protocol sequences

The protocol sequences of GPS messaging shall be the protocol sequences defined in clause 29.3.3 of the present document.

### 29.5.6.2 PDU description tables

The GPS protocol uses the full TL protocol. Additional information elements are present in the SDS-TRANSFER PDU.

### 29.5.6.3 GPS transfer SDU

The GPS transfer is done by use of an SDS-TRANSFER with additional information elements embedded in the user data portion of the SDS-TRANSFER. The GPS SDU shall be encoded as defined in table 454.

**Table 454: GPS SDU contents**

Information element	Length	Type	C/O/M	Remark
GPS coding scheme	8	1	M	As defined in table 455
GPS data	Variable	1	M	

## 29.5.7 GPS coding scheme

For protocols carrying GPS data, the GPS coding scheme information element shall be as defined in table 455.

**Table 455: GPS coding scheme information element contents**

Information element	Length	Value	Remark
GPS coding scheme	8	00000000 <sub>2</sub>	NMEA 0183 [29]
		00000001 <sub>2</sub>	RTCM SC-104 [30]
		00000010 <sub>2</sub>	TETRA locator protocol (TLP)
		00000011 <sub>2</sub> to 01111111 <sub>2</sub>	Reserved
		10000000 <sub>2</sub> to 11111111 <sub>2</sub>	Available for user application definition, see note

NOTE: Identities of these applications should be allocated by a central body in order to support interoperability.

NOTE: This list only defines a subset of the available data coding schemes for GPS. The list should be expected to expand as more data coding schemes are adopted.

## 29.5.8 Wireless Application Protocol (WAP)

Wireless Application Protocol (WAP) is a result of continuous work to define an industry wide standard for developing applications over wireless communication networks. The scope for the WAP working group is to define a set of standards to be used by service applications, refer to IETF RFC 1994 [22]. The upper layers of WAP will be independent of the underlying wireless network, while the data link layer might be adapted to specific features of underlying bearers. However, by keeping the data link layer interface, as well as the basic features, consistent global interoperability can be achieved using mediating gateways.

### 29.5.8.1 Protocol sequences

WAP need not use the SDS-TL data transfer services as those will only add overhead over the normal WAP operation. For WAP protocol sequences, the reader is referred to WAP-100 [39].

### 29.5.8.2 PDU description tables

WAP need not use the SDS-TL data transfer service PDUs as those will only add overhead, refer to clause 29.5.1.2. The minimum standardised information element of WAP is the Protocol Identifier. For all other aspects of WAP the reader is referred to WAP-100 [39].

---

## Annex A (normative): LLC timers and constants

This annex lists the LLC timers and constants in the MS.

Where indicated, a value should be chosen by the MS designer from within a given range. For the other timers and constants, a default value is given. The default value shall be used by the MS unless it received a different value when it subscribed to that network.

---

### A.1 LLC timers

Timers T.251, T.252, T.261, T.263 and T.265 are defined in terms of downlink signalling frames for the control channel on which the downlink message is expected. When counting downlink signalling frames, the MS should normally count all frames, except that:

- on an assigned channel, the MS shall count only those downlink frames that are available for control signalling on that channel; see note, however, that the BS may choose to send a PDU to the MS by stealing from the downlink TCH;
- if the MS is transmitting traffic then:
  - for timer T.251, and if the stealing repeats flag is set for the PDU being sent, the MS shall count all downlink frames (irrespective of whether they are available for control signalling);
  - otherwise, the MS shall count only those downlink frames that it is required to monitor (according to the assigned monitoring pattern(s)) and that are available for control signalling, see note, however, that the BS may choose to send a PDU to the MS by stealing from the downlink TCH in one of the monitored slots;

NOTE 1: For a multi-slot channel, if the MS is not frequency full duplex, and if the BS assigns monitoring pattern(s) that the MS is not capable of following, then, when counting downlink frames, the MS counts only those frames containing at least one slot that it is able to monitor and that is available for control signalling.

- if the MS is in minimum mode, the MS shall count only frame 18; see note, however, that the BS may choose to send a PDU to the MS in slot 1 during frames 2 to 17;
- on a time-shared MCCH, the MS shall count only frames reserved for this BS; see note, however, that the BS may choose to send a PDU to the MS in one of the common frames.

T.251 Sender re-try timer:

Default value = 4 signalling frames.

T.252 Acknowledgement waiting timer:

Default value = 9 signalling frames.

T.261 Set-up waiting timer:

Default value = 4 signalling frames.

T.263 Disconnection waiting timer:

Default value = 4 signalling frames.

T.265 Reconnection waiting timer:

Default value = 4 signalling frames.

T.271 Receiver not ready validity timer for the data sending entity:

Default value = 36 TDMA frames.

NOTE 2: The value of this timer should exceed the value for the data receiving entity T.272.

T.272 Receiver not ready validity timer for the data receiving entity:

Default value = 18 TDMA frames.

---

## A.2 LLC constants

Constants N.252, N.253, N.262, N.263, N.265, N.273, N.274 and N.282 define the maximum number of retransmissions or repetitions. The maximum number of transmissions (including the first transmission) is therefore the specified value + 1.

N.251 Maximum length of TL-SDU (basic link):

This is the maximum length of one TL-SDU if the optional Frame Check Sequence (FCS) is used.

Default value = 2 595 bits (i.e. approximately 324 octets).

The FCS is optional. If the FCS is not used, the TL-SDU part may be larger by four octets.

N.252 Maximum number of TL-SDU retransmissions for acknowledged basic link service:

MS designer choice from range 3 to 5 if the stealing repeats flag is set;

MS designer choice from range 1 to 5 if the stealing repeats flag is not set.

N.253 Number of TL-SDU repetitions in unacknowledged basic link service:

MS designer choice from range 1 to 5.

N.261 Advanced link number:

This value is defined during the set-up of the advanced link (see AL-SETUP PDU definition). Range: (1; 4).

N.262 Maximum number of connection set-up retries:

MS designer choice from range 1 to 5.

N.263 Maximum number of disconnection retries:

MS designer choice from range 3 to 5.

N.264 Number of timeslots used per TDMA frame:

This value is defined during the set-up of the advanced link (see AL-SETUP definition). Range: (1;4).

N.265 Reconnection retries:

MS designer choice from range 0 to 5.

N.271 Maximum length of TL-SDU (advanced link):

This is the maximum length of one TL-SDU including the FCS, it is defined during the set-up of the advanced link (see AL-SETUP PDU definition), Range: (32, 4 096) octets.

N.272 Window size for TL-SDU in acknowledged service:

This value is defined during the set-up of the advanced link, (see AL-SETUP definition). Range: (1;3).

N.273 Maximum number of TL-SDU retransmissions:

This value is defined during the set-up of the advanced link (see AL-SETUP definition). Range: (0;7).

N.274 Maximum number of segment retransmissions:

This value is defined during the set-up of the advanced link, (see AL-SETUP definition). Range: (0;15).

N.281 Window size for TL-SDU in unacknowledged service:

This value is defined during the set-up of the advanced link (see AL-SETUP definition). Range: (1;3).

N.282 Number of repetitions for unacknowledged information:

This value is defined during the set-up of the advanced link (see AL-SETUP definition). Range: (0;7).

---

## Annex B (normative): MAC timers and constants

This annex lists the MAC timers and constants in the MS.

Where indicated, a value should be chosen by the MS designer from within a given range. For the other timers and constants, a default value is given. The default value shall be used by the MS unless it received a different value when it subscribed to that network.

---

### B.1 MAC timers

Timers T.202 and T.206 are defined in terms of downlink signalling frames for the control channel on which the downlink message is expected. When counting downlink signalling frames, the MS should normally count all frames, except that:

- on an assigned channel, the MS shall count only those downlink frames that are available for control signalling on that channel; see note, however, that the BS may choose to send a PDU to the MS by stealing from the downlink TCH;
- if the MS is transmitting traffic then the MS shall count only those downlink frames that it is required to monitor (according to the assigned monitoring pattern(s)) and that are available for control signalling, see note, however, that the BS may choose to send a PDU to the MS by stealing from the downlink TCH in one of the monitored slots;

NOTE 1: For a multi-slot channel, if the MS is not frequency full duplex, and if the BS assigns monitoring pattern(s) that the MS is not capable of following, then, when counting downlink frames, the MS counts only those frames containing at least one slot that it is able to monitor and that is available for control signalling.

- if the MS is in minimum mode, the MS shall count only frame 18; note, however, that the BS may choose to send a PDU to the MS in slot 1 during frames 2 to 17;
- on a time-shared MCCH, the MS shall count only frames reserved for this BS; see note, however, that the BS may choose to send a PDU to the MS in one of the common frames.

T.201 Event label inactivity time-out:

Default value = 30 multiframes.

T.202 Fragmentation time-out:

Default value = 9 downlink signalling frames.

T.205 Random access time-out:

MS designer choice from 5 multiframes to 60 multiframes.

T.206 Reserved access waiting time-out:

Default value = 18 downlink signalling frames.

T.208 Inactivity time-out on assigned SCCH:

Default value = 30 multiframes.

T.209 Inactivity time-out on traffic channel:

Default value = 18 multiframes.



T.210 Timer for returning to energy economy mode:

Default value = 18 TDMA frames.

T.211 AACH time-out for transmission of TCH:

Default value = 36 TDMA frames.

T.212 AACH time-out for reception of TCH:

Default value = 18 TDMA frames.

T.213 DTX timer:

Default value = 18 TDMA frames.

T.214 Stealing timer:

Default value = 6 uplink opportunities.

T.215 Timer for traffic receive authorization if obeying channel allocation after delay:

Default value = 18 TDMA frames.

T.216 Timer for leaving assigned channel after channel replacement:

Default value = 2 TDMA frames.

T.220 Timer for returning to dual watch reception cycle:

Default value = 18 TDMA frames.

NOTE 2: For correct operation of the procedures,  $T.206 \geq T.202$ .

---

## B.2 MAC constants

N.202 Maximum size of TM-SDU:

2 632 bits (i.e. 329 octets).

N.203 Number of timeslots without a fragment before MAC will discard an uncompleted TM-SDU:

Default value greater than or equal to 4.

N.208 Number of wrong AACHs to leave assigned channel:

Default value = 3.

N.210 Quality threshold for serving cell:

Default value = 4.

N.211 Number of invalid AACHs to stop transmission of TCH:

Default value = 3.

N.212 Number of invalid AACHs to stop reception of TCH:

Default value = 3.

N.213 Number of valid AACHs to allow reception of TCH:

Default value = 3.

N.214 Number of transmissions if stealing repeats flag is set:

Default value = 4.

---

## Annex C (normative): Mathematical definition of Frame Check Sequence (FCS)

The FCS value corresponding to a given frame is defined by the following procedure:

- 1) the first 4 octets (first 32 bits) of the frame are complemented. If there are less than 32 bits, then those bits will be complemented;
- 2) the  $n$  bits of the frame are then considered to be the co-efficients of a polynomial  $M(x)$  of degree  $n - 1$ ;
- 3)  $M(x)$  is multiplied by  $x^{32}$  and divided by  $G(x)$ , producing a remainder  $R(x)$  of degree less than 32;
- 4) the co-efficients of  $R(x)$  are considered to be a 32-bit sequence;
- 5) the 32-bit sequence is complemented and the result is the FCS.

The generator polynomial is defined as:

$$G(x) = 1 + X + X^2 + X^4 + X^5 + X^7 + X^8 + X^{10} + X^{11} + X^{12} + X^{16} + X^{22} + X^{23} + X^{26} + X^{32}$$

NOTE: There is a minor difference in the rule 1 compared to ISO/IEC 13239 [2] in the case when the frame length is less than 32 bits.

## Annex D (informative): MAC scenarios for use of traffic channel

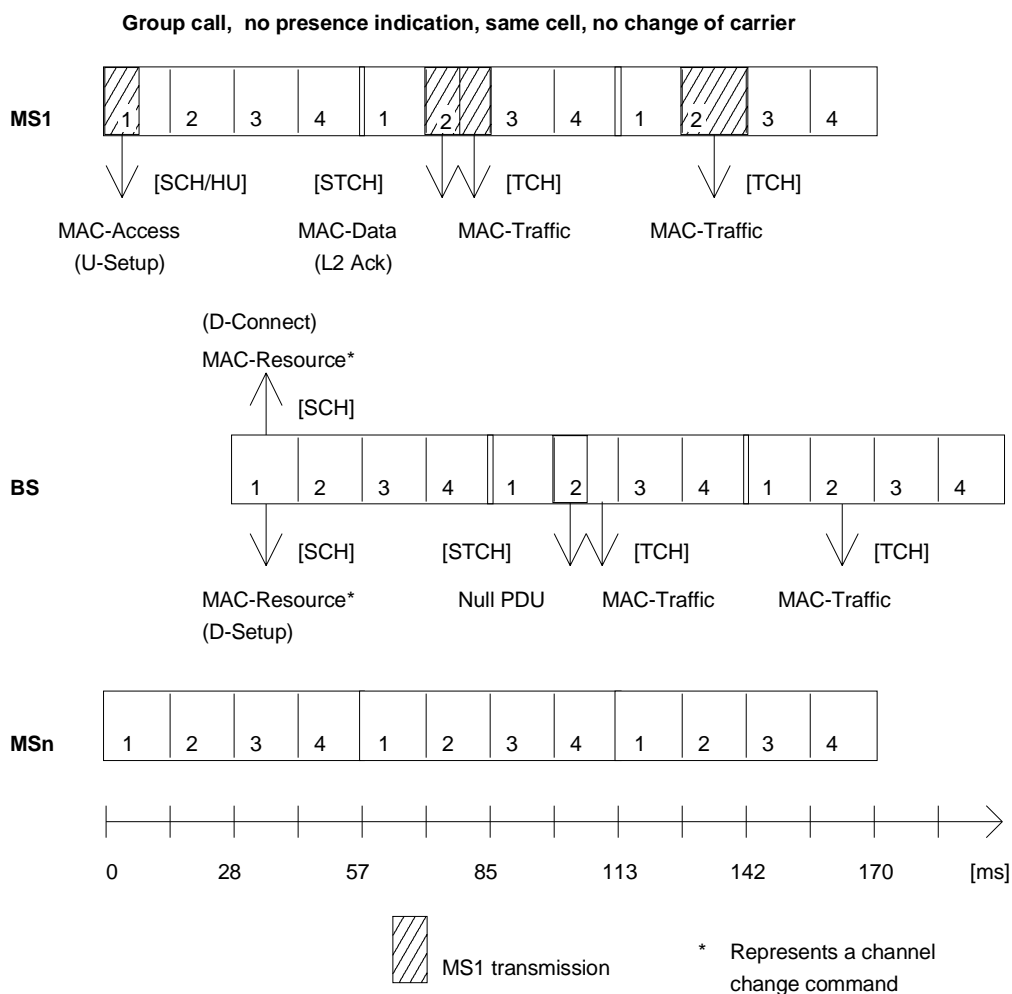
This annex shows some examples of scenarios for use of an assigned channel for a circuit mode call. It demonstrates methods for using the MAC TMD-SAP procedures described in clause 23.8 and shows some possible CMCE signalling scenarios.

The BS may use the protocol facilities provided for call set-up and channel usage for circuit mode calls in many different ways. For example:

- early, medium or late assignment;
- transmission, quasi-transmission or message trunking;
- simplex or duplex calls;
- different strategies in case of transmission errors.

Figure D1 to figure D10 illustrate a few examples of signalling related to circuit mode calls. It should be seen that there are many other possible scenarios depending on the BS's methods for allocating resources. It should also be noted that some of the features represented here are optional.

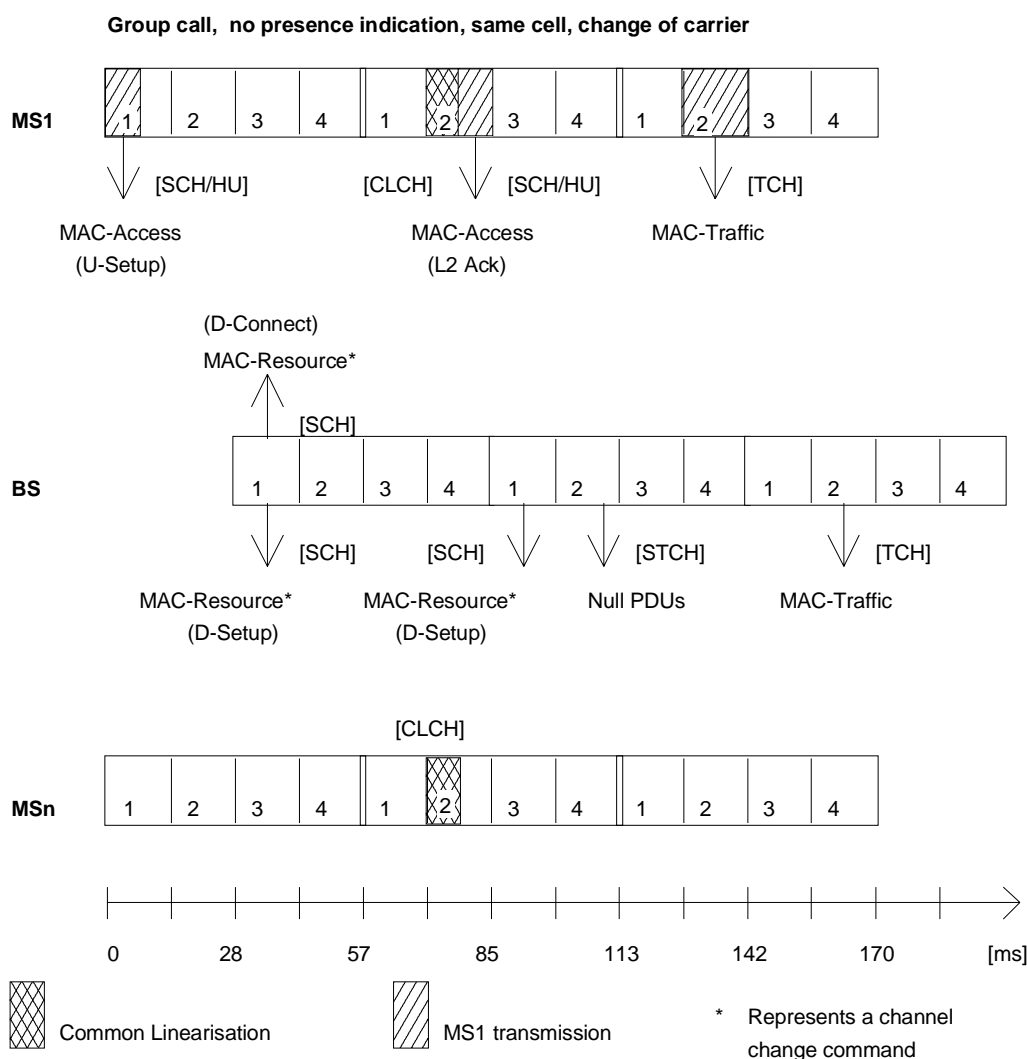
In the figures, \* beside a BS PDU represents a channel change command. In all the examples shown, the position of any slot grant is on the allocated channel.



**Figure D.1: Initial access message exchange in group call set-up procedure**

Figure D.1 illustrates a call set-up of a group call on a single cell (without presence indication). The assigned channel is on the main carrier, so no CLCH is needed. The D-CONNECT PDU authorizes the calling MS to start transmitting traffic on the assigned channel and the D-SETUP PDU authorizes the called members of the group to receive traffic. In this example, the BS does not grant a subslot for the calling MSs layer 2 acknowledgement to the D-CONNECT PDU, so the MS steals from the first traffic slot. On the downlink, the BS replaces the half slot with the Null PDU on STCH. The BS may send back-up D-SETUP PDUs (not shown) to the called group.

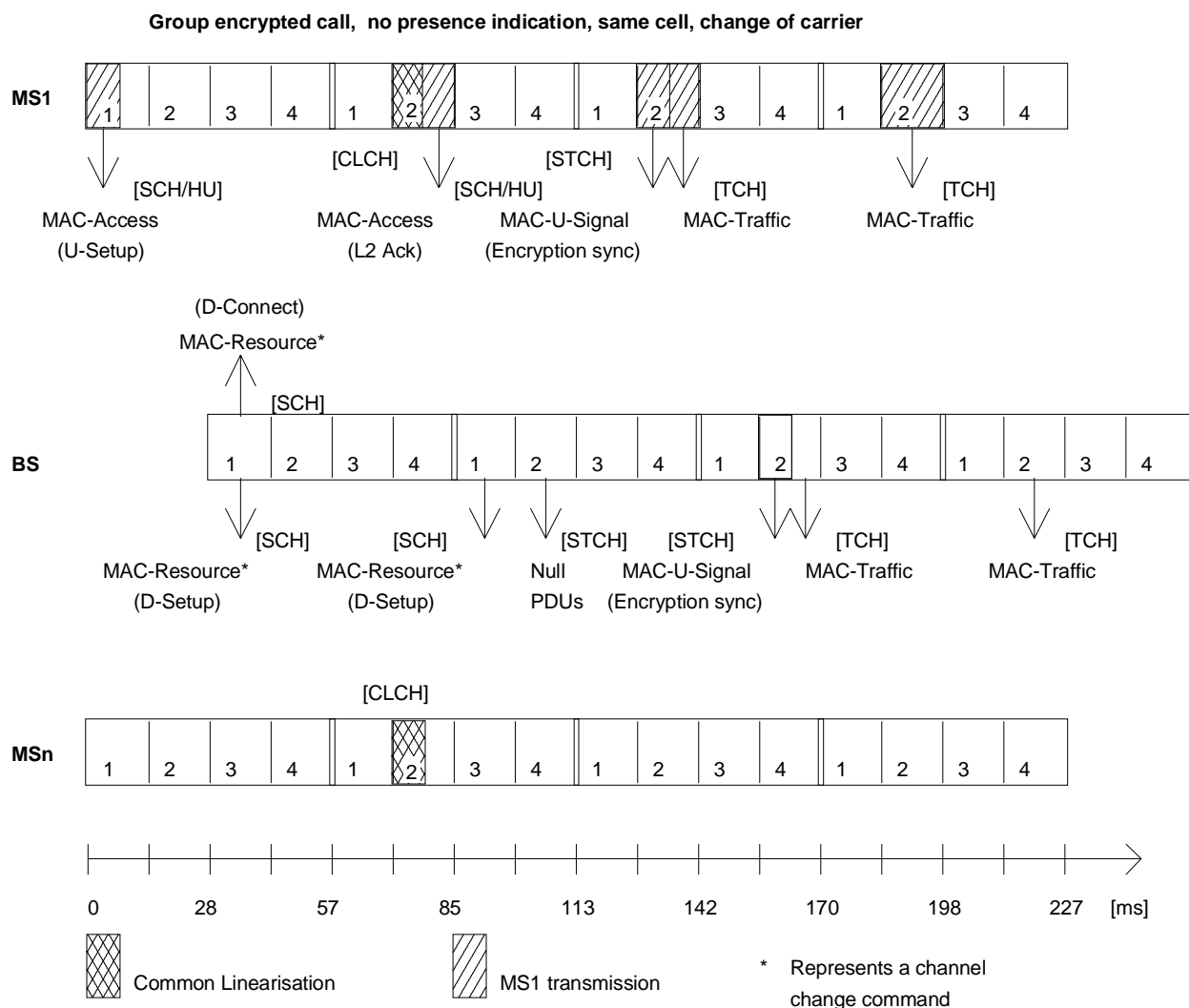
In figure D.1, the BS instructs the calling MS to send a layer 2 acknowledgement to the D-CONNECT PDU. This is an optional feature. For example, the BS may choose instead to send the D-CONNECT PDU several times without demanding the layer 2 acknowledgement and so allowing TCH to start one half slot earlier. This general principle applies also to other figures in this annex.



**Figure D.2: Initial access message exchange in group call set-up procedure**

Figure D.2 illustrates another call set-up of a group call on a single cell (without presence indication). The assigned channel is not on the main carrier, so the BS gives "Immediate CLCH Permission" to the calling MS with the channel allocation. In this example, the BS grants the second subslot (after the CLCH) for the calling MSs layer 2 acknowledgement; the MS can then start full-slot TCH in the next slot 2. The BS also gives "Immediate CLCH permission" with the first D-SETUP PDU to the group members. In the example, the BS sends a back-up D-SETUP message on the MCCH. There is "No Immediate CLCH Permission" in the back-up message, because the calling MS has already started traffic transmission.

In figure D.2, traffic from the source is not available for transmission in the first downlink slot on the allocated channel. The BS therefore sends C-plane STCH + STCH on the downlink, in this case containing null C-plane signalling, until traffic from the source is available.

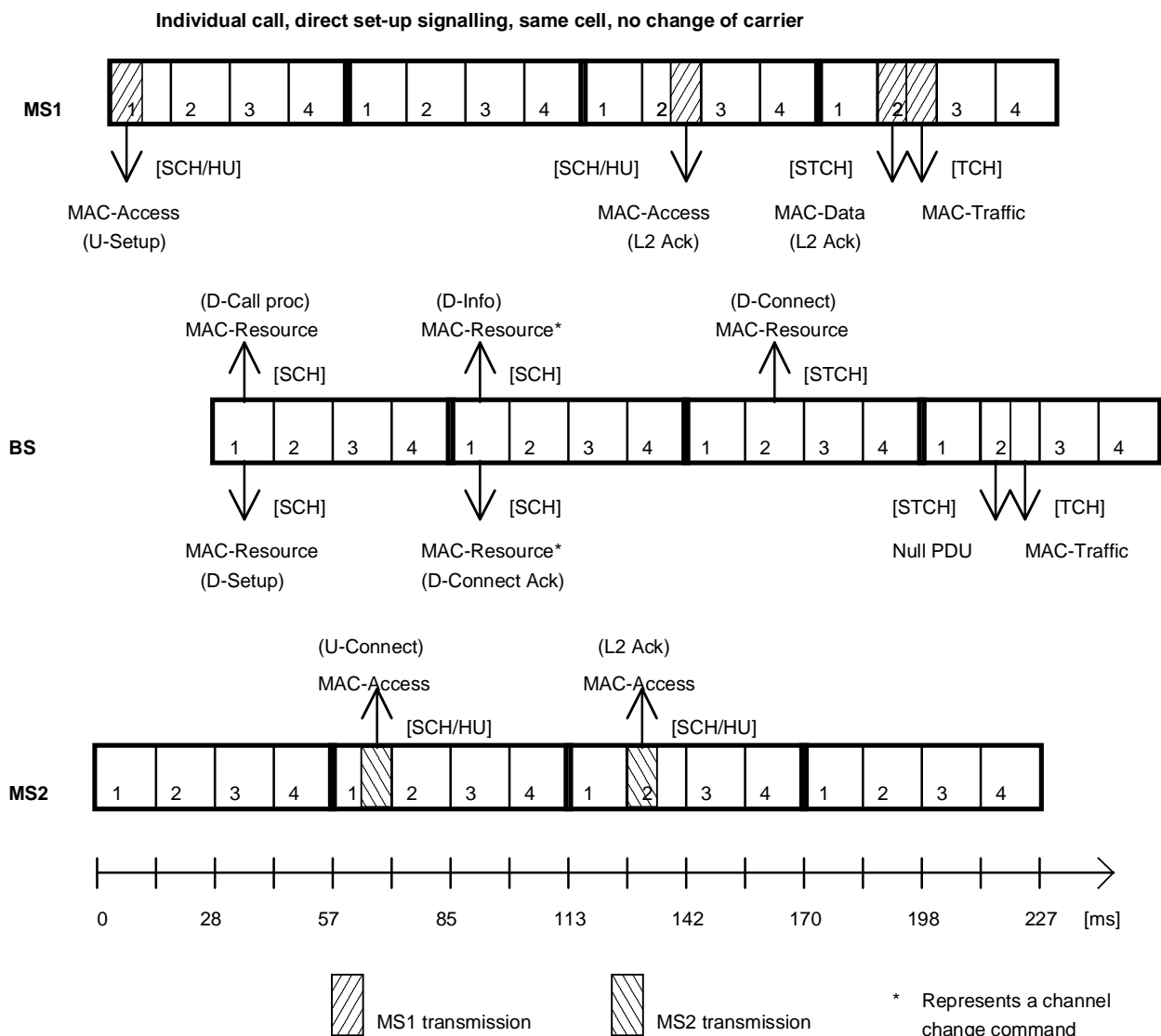


**Figure D.3: End-to-end signalling for starting encryption of speech (group call)**

Figure D.3 is similar to figure D.2 except that this call uses end-to-end encryption, so the calling MS steals from the first traffic slot to send U-plane signalling. This message is passed on to the receiving group.

Figure D.4 illustrates a call set-up of an individual call on a single cell (with direct call set-up). The BS checks the availability of the called MS before allocating a traffic channel. The assigned channel is on the main carrier, so no CLCH is needed. In this example, the BS sends D-CONNECT-ACK with the channel allocation to the called MS, authorizing it to receive traffic. However, it waits for the called MS to respond before authorizing the calling MS to start transmitting traffic (D-CONNECT PDU).

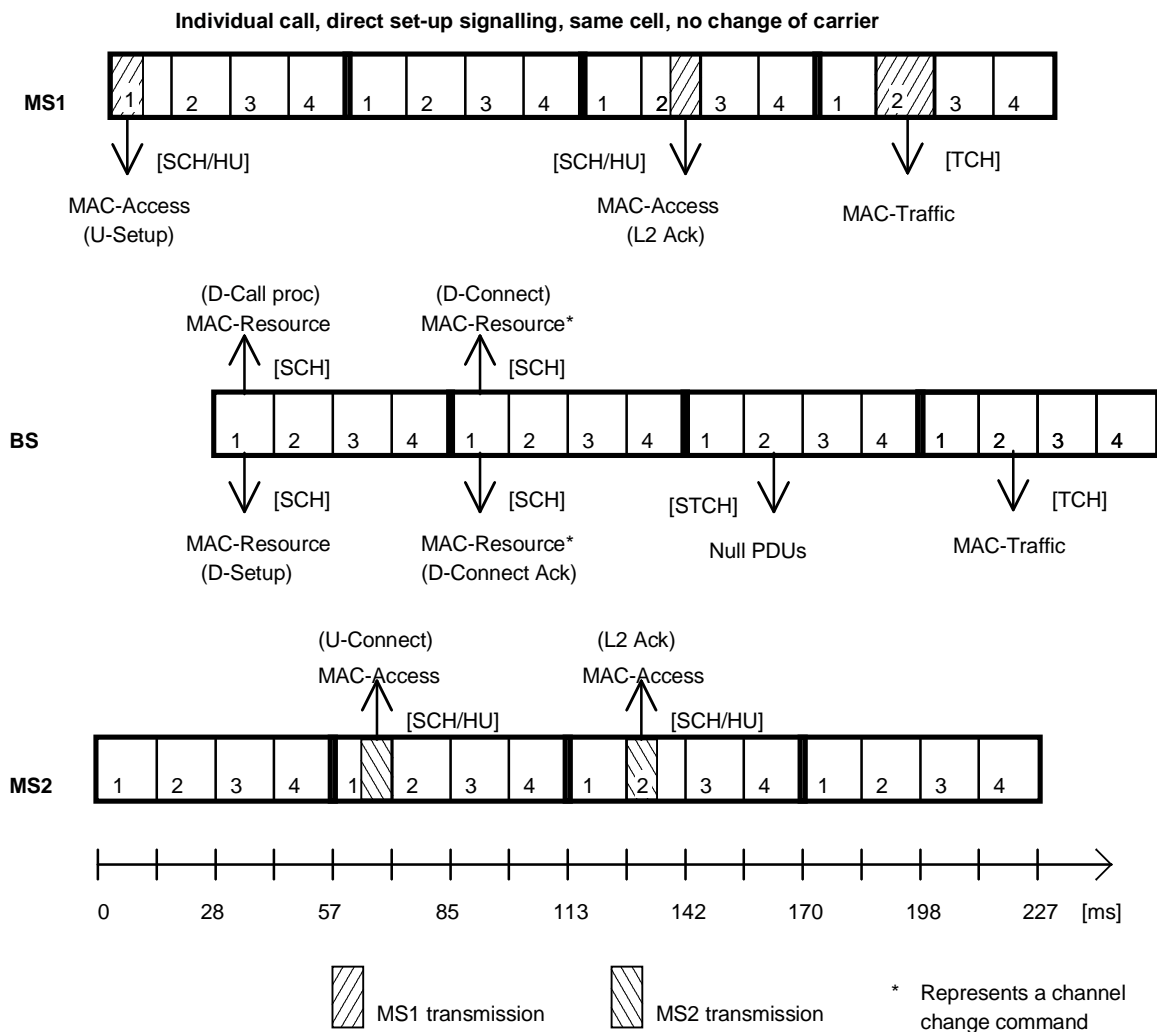
In the example shown, the BS receives a layer 2 acknowledgement from the called MS in the granted subslot. If it had not received a PDU in the granted subslot, then it cannot know whether it was the downlink message that failed or only the uplink response. So it does not know whether the MS is still receiving the MCCH or whether it has moved to slot 2. Using the method illustrated, the BS can repeat the D-CONNECT ACK on the MCCH and also page the MS on slot 2 until it receives a layer 2 acknowledgement on slot 2. The BS can then authorize the calling MS to transmit.



**Figure D.4: Initial access message exchange in individual call set-up procedure**

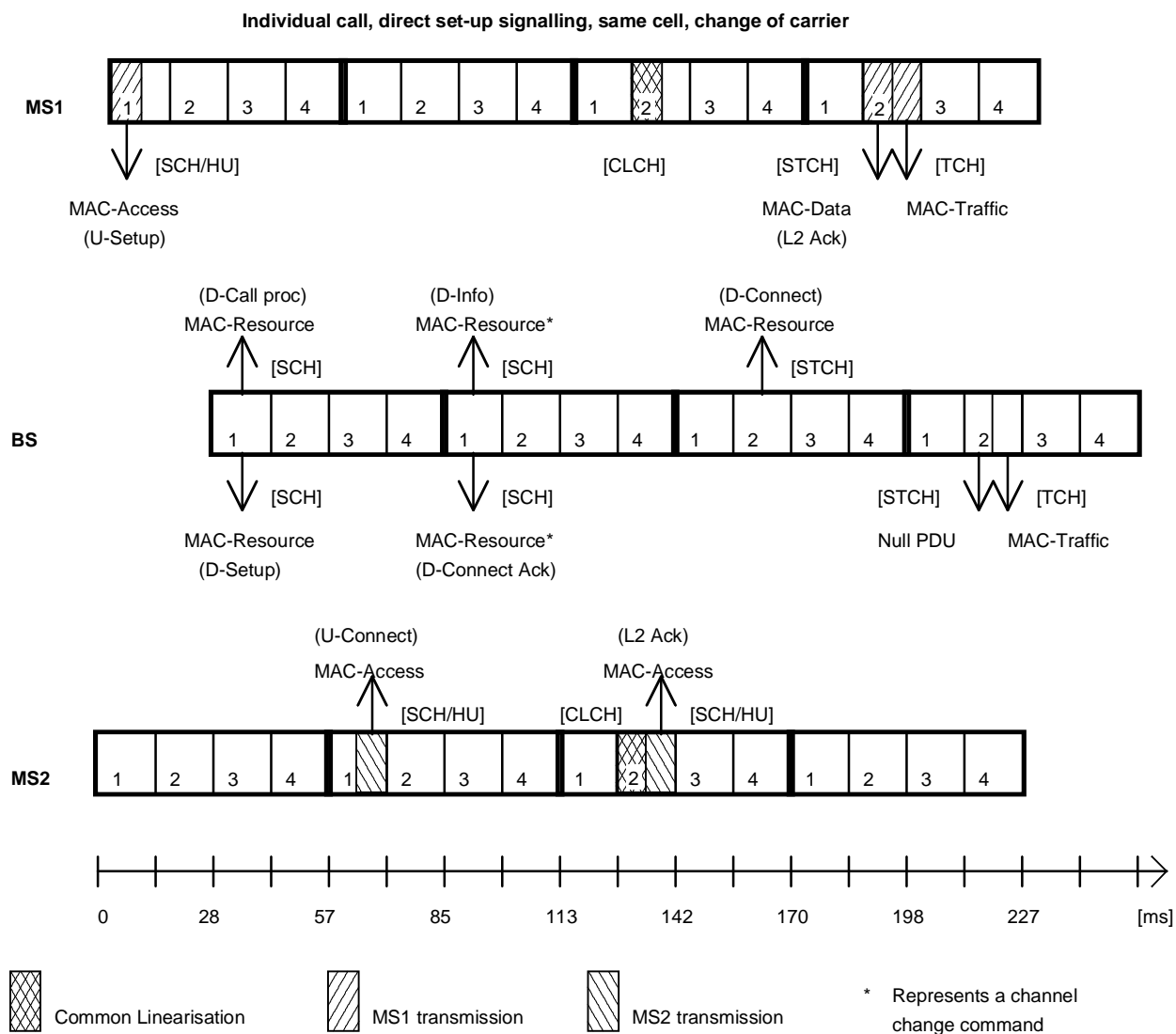
The signalling method shown in figure D.4 can be used more generally when there may be a queuing delay between D-CALL PROCEEDING and channel allocation. Whereas, in the case illustrated, with no queuing delay, the BS could have delayed the D-CALL PROCEEDING until channel allocation (replacing D-INFO).

Alternatively to the method shown in figure D.4, the BS may send D-CONNECT to the calling MS with the channel allocation (instead of D-INFO). This method is illustrated in figure D5. It can be seen that this allows TCH to start one half slot earlier. However, if the called MS misses the D-CONNECT ACK PDU, it will not receive the first part of the traffic. Also, for repeat signalling, the BS must either use the unacknowledged service or grant a subslot on the MCCH (i.e. before the channel change) or delay the layer 2 acknowledgement until frame 18.



**Figure D.5: Initial access message exchange in individual call set-up procedure**

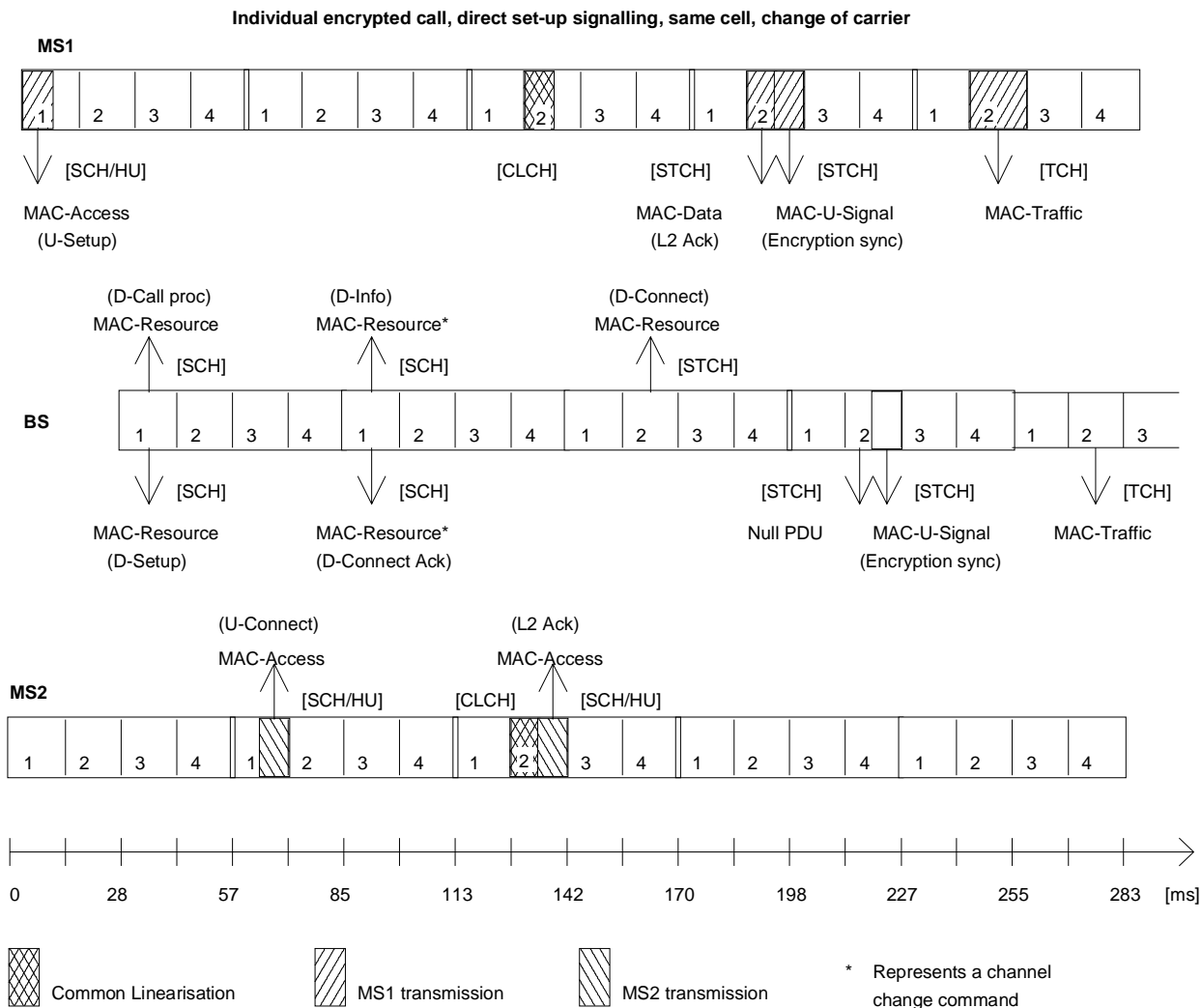
Figure D.6 is similar to figure D.4, but with a change of carrier.



**Figure D.6: Initial access message exchange in individual call set-up procedure**

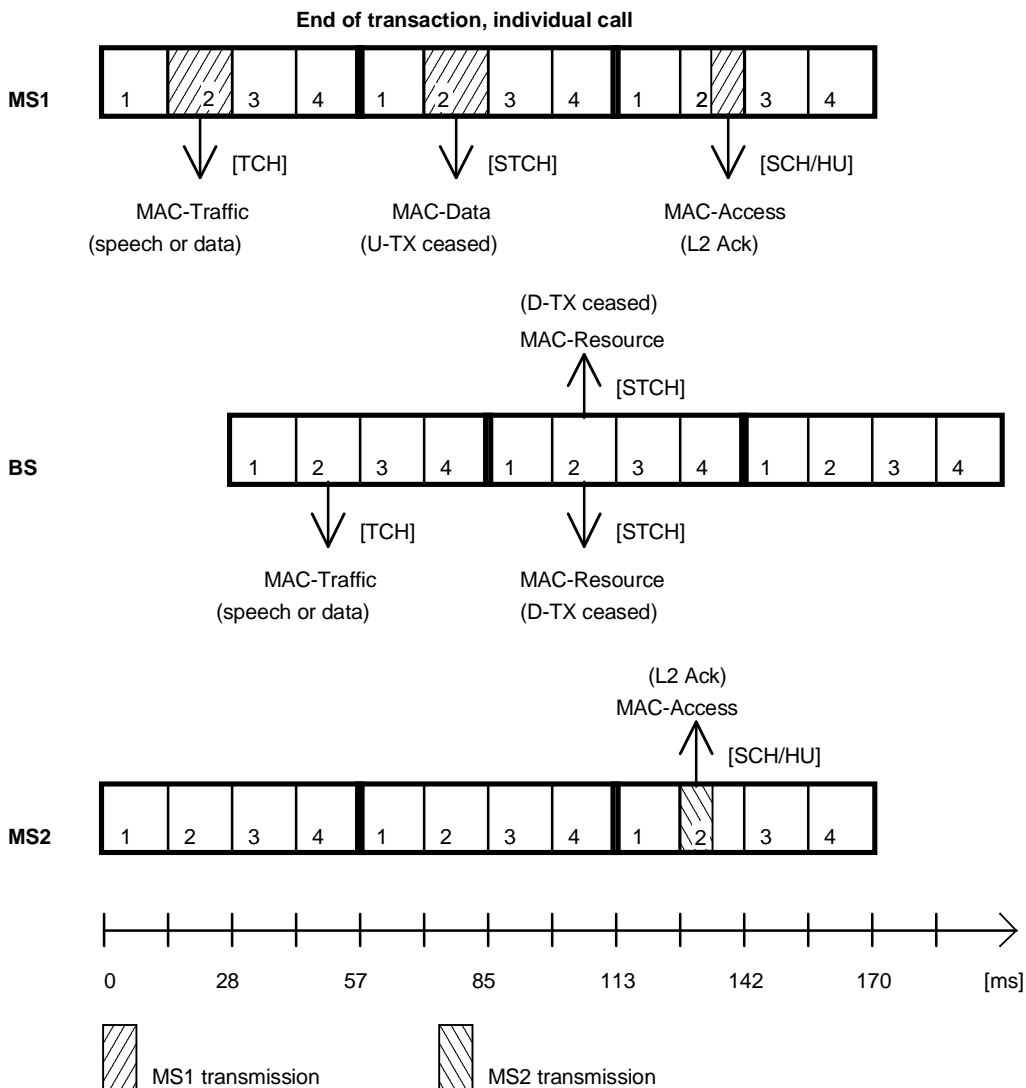


Figure D.7 is similar to figure D.6, except that this call uses end-to-end encryption.



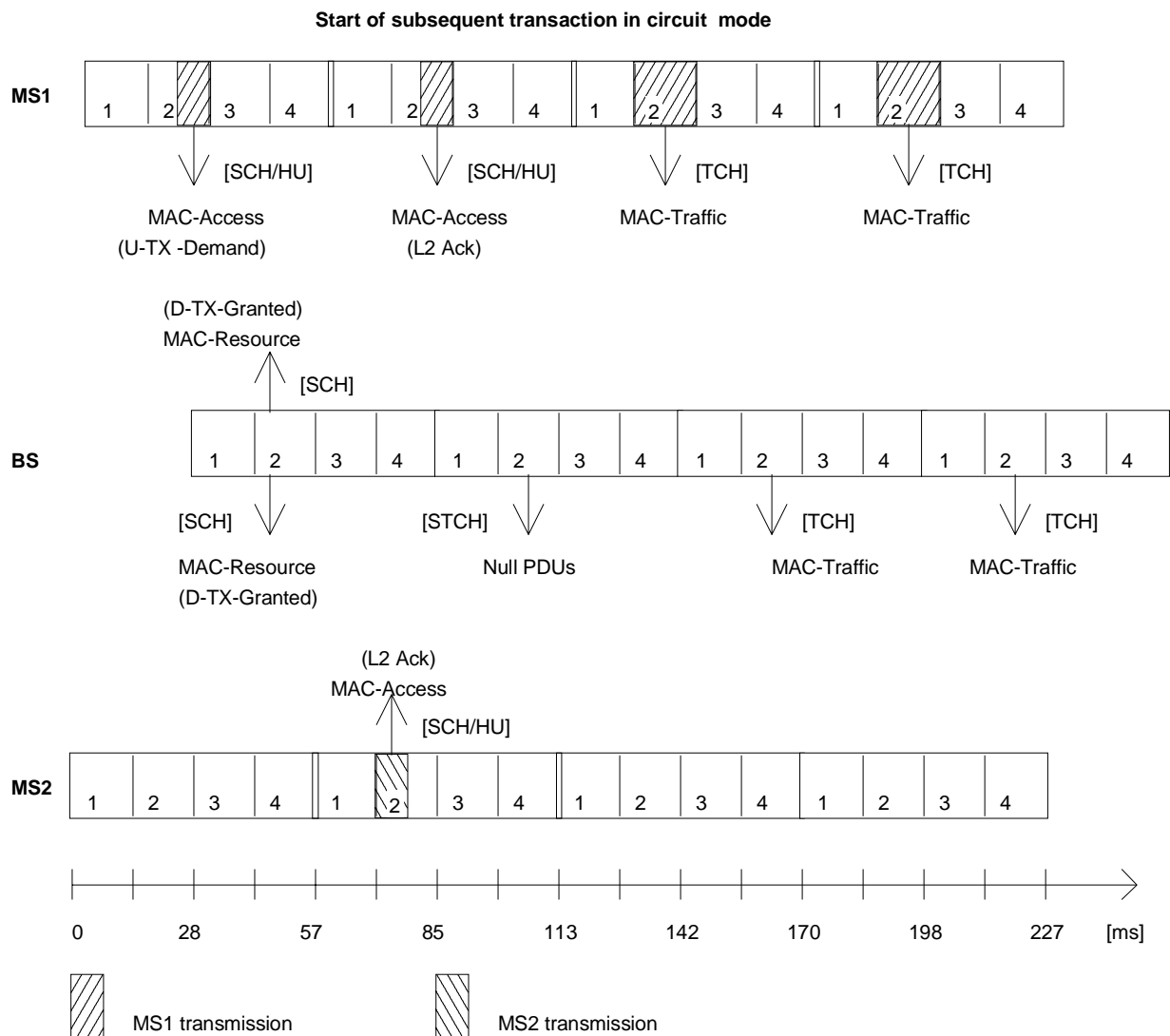
**Figure D.7: End-to-end signalling for starting encryption of speech (individual call)**

Figure D.8 shows an example of signalling at the end of an "over" in an individual call. In this example, the BS requires confirmation of receipt of D-TX-CEASED from both MSs.



**Figure D.8: End of transaction sequence in circuit mode**





**Figure D.10: Start of subsequent transaction in circuit mode**

## Annex E (normative): PDU encoding rules and examples

This annex defines general PDU encoding rules and examples for some PDUs, which may require further clarification.

### E.1 PDU encoding rules for CMCE, MM and SNDCP PDUs

#### E.1.1 General PDU encoding rules for CMCE, MM and SNDCP PDUs

The general format of the PDUs are defined in table E.1. The information element Protocol identifier is present for each PDU before the PDU type element although not shown in the PDU descriptions. The MLE sub-layer shall add/remove Protocol identifier element before sending the PDU to lower layers or passing the PDU to other layer 3 entities.

The elements shall be transmitted in the order specified by the table with the top element being transmitted first (before interleaving). The content of an information element is represented by a binary value and the most significant bit of that binary value shall be transmitted first (before interleaving).

**Table E.1: CMCE, MM and SNDCP PDU layout**

Information element	Length	Value	Remark
PDU type	varies		Dependent on the protocol entity
Type 1 element (1)	varies		See definitions below
Type 1 element (2)	varies		See definitions below
...etc.	...etc.		...etc.
Type 1 element (m)	varies		See definitions below
Conditional element to previous element	varies		See definitions below
...etc.	...etc.		...etc.
Type 1 element (m+1)	varies		See definitions below
...etc.	...etc.		...etc.
Type 1 element (n)	varies		See definitions below
Optional bit (O-bit), see note 1	1	0	No optional type 2 or type 3/4 elements follow
		1	Optional type 2 or type 3/4 elements follow
Presence bit (P-bit) (1)	1	0	The type 2 element (1) is not present
		1	The type 2 element (1) is present
Type 2 element (1)	varies		See definitions below
Presence bit (P-bit) (2)	1	0	The type 2 element (2) is not present
		1	The type 2 element (2) is present
Type 2 element (2)	varies		See definitions below
...etc.	...etc.		...etc.
Presence bit (P-bit) (m)	1	0	The type 2 element (2) is not present
		1	The type 2 element (2) is present
Type 2 element (m)	varies		See definitions below
Conditional element to previous element	varies		See definitions below
...etc.	...etc.		...etc.
Presence bit (P-bit) (m+1)	1	0	The type 2 element (2) is not present
		1	The type 2 element (2) is present
Type 2 element (m+1)	varies		See definitions below
...etc.	...etc.		...etc.
Presence bit (P-bit) (n)	1	0	The type 2 element (n) is not present
		1	The type 2 element (n) is present
Type 2 element (n)	varies		See type 2 element (1)

Information element	Length	Value	Remark
More bit (M-bit) (1)	1	0	No type 3/4 elements follow
		1	Type 3/4 elements follow
Type 3 element identifier (1)	4		See definitions below
Length indicator (1)	11	0	Reserved
		1-2 047	Length of the following type 3 Element in bits:
Type 3 element (1)	varies		See definitions below
More bit (M-bit) (2)	1	0	No more type 3/4 elements follow
		1	More type 3/4 elements follow
Type 3 element identifier (2)	4		See type 3 element identifier (1)
Length indicator (2)	11		See length indicator (1)
Type 3 element (2)	varies		See type 3 Element (1)
More bit (M-bit) (3)	1	0	No more type 3/4 elements follow
		1	More type 3/4 elements follow
Type 4 element identifier (3)	4		See type 3 element identifier (1)
Length indicator (3)	11		Total length of the following type 4 Elements in bits (including the Number of repeated elements):
Number of repeated elements (3)	6	0	Reserved
		1-63	Indicates the number of repeated type 4 elements
Type 4 sub-element (3.1)	varies		See definitions below
Type 4 sub-element (3.2)	varies		See definitions below
...etc.	...etc.		...etc.
Type 4 sub-element (3.n)	varies		See definitions below
More bit (M-bit) (4)	1	0	No more type 3/4 elements follow
		1	More type 3/4 elements follow
...etc.	...etc.		...etc.
More bit (M-bit) (n)	1	0	No more type 3/4 elements follow
		1	More type 3/4 elements follow
Type 3 element identifier (n)	4		See type 3 element identifier (1)
Length indicator (n)	11		See length indicator (1)
Type 3 element (n)	varies		See type 3 element (1)
More bit (M-bit) (n+1) = 0	1	0	Last M-bit (Least Significant Bit (LSB) in the PDU) = 0

#### Presence of O-bit, P-bit and M-bit:

The O-bit is always present straight after last type 1 element or element conditional to the last type 1 element unless stated otherwise in the PDU description. In case O-bit has value "0", the PDU contains no more elements; no P-bits for type 2 elements, no type 2 elements, no M-bits nor type 3 or type 4 elements.

In case the O-bit has value 1, then at least one type 2, type 3 or type 4 element follows. In this case there is P-bit for each type 2 element which is defined for the PDU; if the type 2 element is present in the PDU then the corresponding P-bit has value 1, if the type 2 element is not present, then the corresponding P-bit has value 0.

NOTE 1: There is no P-bit before an element that is conditional to type 2 element.

In case the O-bit has value 1, then after the last type 2 element or element that is conditional to the last type 2 element, or after the P-bit indicating that the last type 2 element is not present, there is always an M-bit telling whether there are any type 3 or type 4 elements present in the PDU. For each type 3 or type 4 element present in the PDU there is preceding M-bit having value 1. After the last type 3 or type 4 element, there is always one M-bit (the last bit in the PDU) having value 0.

NOTE 2: If there are type 2 element(s) present in the PDU and no type 3/4 elements are specified for the PDU, the M bit is present and set to "0" unless stated otherwise in the PDU description.

NOTE 3: In case the PDU definition does not contain any type 2 elements and the PDU contains type 3 or type 4 elements, then there is the O-bit having value 1 after the last type 1 element or element conditional to the last type 1 element, followed by M-bit having value 1 and then the first type 3 or type 4 element.

NOTE 4: If there is no type 2 nor type 3 nor type 4 elements specified for the PDU the O-bit is present and set to "0" unless stated otherwise in the PDU description.

### Length of the elements:

The length of a type 1 or type 2 element or element conditional to type 1 or type 2 element is either fixed as indicated in the "Length" column in the PDU or the length may be indicated by the value of a preceding element to which this element is conditional.

NOTE 5: A conditional element may also be present in the PDU varying times as indicated by the value of a preceding element to which this element is conditional. In such case the element is marked as "Repeatable" in the PDU.

The length of a type 3 and type 4 element is indicated by the preceding "Length indicator" element.

NOTE 6: Because of these PDU encoding rules, only adding of a type 3 or type 4 element can be done without causing backward incompatibility problems, as the decoding entity can pass unknown type 3 and type 4 elements because their length is indicated in the PDU whereas the length of type 1 or type 2 element must be known beforehand.

### Encoding rules for PDU:

The element type defines the encoding rule applied to an element as follows:

- Type 1 elements are mandatory and shall be placed within the PDU in a fixed order as specified in the PDU description tables. Type 1 elements shall be placed before any type 2 or type 3 elements in the PDU encoding. In addition the PDU may contain elements that are conditional to type 1 elements; they are present only if the corresponding type 1 element has specified value. These conditional elements are placed after the type 1 elements to which they are conditional;
- Type 2 elements are optional and shall be placed within the PDU in a fixed order as specified in the PDU description tables. Type 2 elements shall be placed after all type 1 elements and elements conditional to type 1 elements, and before any type 3 elements in the PDU encoding. In addition the PDU may contain elements that are conditional to type 2 elements; they are present only if the corresponding type 2 element has specified value. These conditional elements are placed after the type 2 elements to which they are conditional;
- Type 3 and type 4 elements are optional and shall be placed within the PDU in numerical order as specified within the "type 3/4 Element Identifier" element. Type 3/4 Elements shall be placed after any type 1 and type 2 elements in the PDU encoding. Each type 3 and type 4 element shall be preceded by a "type 3/4 Element Identifier" element and a "Length Indicator" element in that order. In addition for each type 4 element a length indicator shall be followed by the "Number of repeated elements" information element.

NOTE 7: For presentation purposes a set of information elements can be defined as an information element. The set of information sub-elements may contain also optional or conditional elements and also elements consisting of set of sub-elements. The set is encoded into the PDU as if it were a single information element of the indicated type.

The following rules shall apply for decoding of the PDU:

```

DO for all Type 1 elements
  DECODE Type 1 element
    WHILE conditional elements to the type 1 element
      DECODE conditional element
    END WHILE
END DO
DECODE O-bit
IF O-bit set to 'No Optional Elements present'
  THEN END of PDU decoding
ELSE
  DO for all possible Type 2 elements
    DECODE P-bit
    IF P-bit set to 'Present'
      THEN DECODE Type 2 element AND
        WHILE conditional elements to the type 2 element
          DECODE conditional element
        END WHILE
    END DO
  WHILE M-bit set to 'More Type 3/4 elements follows'
    IF element is a Type 4 element
      THEN DECODE Number of repeated elements
        WHILE more type 4 sub-elements
          DECODE Type 4 sub-element
        END WHILE
    ELSE
      DECODE Type 3 element
    END IF
  END WHILE
END of PDU decoding.

```

The encoding rules for sub-elements:

- in case the PDU information element or sub-element definition contains no "Type" column, the sub-elements of the element/sub-element are all considered to be of type 1;
- type 1 element or type 1 sub-element can contain only type 1 sub-elements and conditional elements to type 1 element/sub-element;
- type 2 element or type 2 sub-element can contain only type 1 sub-elements and conditional elements to type 1 element/sub-element;
- element conditional to type 1 or type 2 element or sub-element can contain only type 1 sub-elements and conditional elements to type 1 element/sub-element;

NOTE 8: As no optional elements are specified for the type 1 or type 2 element/sub-element, there is no O-bit (nor M-bit) after the last type 1 sub-element or conditional element.

- type 3 or type 4 element or sub-element can contain sub-elements which can be one of type 1, 2, 3 and 4. In case the type 3 or type 4 element/sub-element definition does not contain optional elements, there is no O-bit after the type 1 sub-elements;
- in case type 3 or type 4 element/sub-element definition contains optional type 2 or type 3 elements, there shall be an O-bit indicating whether the type 3/4 element/sub-element contains any optional elements:
  - in case the type 3 or type 4 element/sub-element contains no optional elements, the O-bit is set to value "no optional elements follow" and no other information shall be included to the type 3 or type 4 element/sub-element;
  - in case the type 3 or type 4 element/sub-element contains optional elements (either type 2 or type 3 or type 4) the O-bit is set to value "optional elements follow" and a P-bit shall be set for each type 2 optional element (if any defined) indicating presence of that element. The P-bit shall indicate either "type 2 element present" or "type 2 element not present";
    - in case the element/sub-element definition does not contain any type 3 or type 4 elements there shall be no M-bit after the last type 2 element or conditional element or the P-bit indicating that the last type 2 element is not present.



- in case the type 3/4 element/sub-element definition contains type 3/4 elements, there shall be a M-bit after the last type 2 element or conditional element or P-bit indicating that last optional type 2 element is not present, indicating whether the element/sub-element contains any type 3/4 elements. The type 3 and type 4 sub-elements are coded similarly as type 3 and type 4 PDU information elements, i.e. type 3 and type 4 sub-element shall be preceded by a "type 3/4 Element Identifier" element and a "Length Indicator" element in that order. In addition in the type 4 sub-element a length indicator shall be followed by the "Number of repeated elements" information element. A further M-bit shall follow each Type 3/4 sub-element to indicate either "type 3/4 element to follow" or "no type 3/4 element to follow". After the last type 3/4 sub-element included the M-bit shall be set to "0" to indicate "no type 3/4 element to follow" in this sub-element.
  - in case the information element/sub-element contains one or more type 3 elements but no type 2 elements are specified for the element/sub-element, an M-bit (having value "type 3/4 elements to follow") shall follow the O-bit (having value "optional elements to follow") placed after the last type 1 element.
  - in case the element/sub-element contains no type 3/4 elements but contains type 2 elements there shall be one M-bit bit indicating "no type 3/4 elements to follow" after the last type 2 element or P-bit indicating that last optional type 2 element is not present as the last bit in the type 3/4 element.

The C/O/M column indicates how the presence of an information element is controlled in the PDU or element/sub-element:

- M: Mandatory information element is always present (mandatory) in the main PDU level and is always present in a sub-element, when the sub-element itself is present. The type of mandatory element is type 1;
- O: Optional information element may be present in the PDU. The protocol state or an implementation choice defines when it is present or not. The type of optional element is either type 2 or type 3 or type 4;
- C: Conditional information element is present as defined in the PDU or element/sub-element description. The presence depends on the value of another preceding information element. If the information element on which the conditional information element is conditional is not present then also the conditional information element is not present. The conditional information element may be also repeated as many times as indicated by a preceding information element.

## E.1.2 PDU encoding examples for CMCE PDUs

Tables E.2 to E.6 present examples of proper CMCE PDU encoding in specific cases.

**Table E.2: D-FACILITY PDU with two SS-PDUs**

Information Element	Length	Type	C/O/M	Value
Protocol discriminator	3	1	M	CMCE
PDU Type	5	1	M	D-FACILITY
Number of SS PDUs	4	1	M	2
Length indicator	11	1	M	variable
SS-PDU contents	variable	1	C	variable
Length indicator	11	1	M	variable
SS-PDU contents	variable	1	C	variable
Optional elements present ?	1	O-bit		0 (no optional elements present in D-FACILITY PDU)

NOTE: When the U/D-FACILITY PDU contains more than a single SS-PDU it is a collection of SS-PDUs which are encoded independently of each other. Each SS-PDU may contain any type of information elements as defined for the SS-PDU.

**Table E.3A: D-FACILITY PDU with "SS not supported" acknowledgement**

Information Element	Length	Type	C/O/M	Value
Protocol discriminator	3	1	M	CMCE
PDU Type	5	1	M	D-FACILITY
Number of SS PDUs	4	1	M	1
Length indicator	11	1	M	12
SS-PDU contents	varies	1	C	12, See next 3 elements
SS-Type	6	1	M	SS-DGNA
SS-PDU Type	5	1	M	SS not supported
Optional elements present ?	1	O-bit		0 (for SS not supported PDU)
Optional elements present ?	1	O-bit		0

**Table E.4: D-FACILITY with SS-DGNA ASSIGN PDU**

Information Element	Length	Type	C/O/M	Value
Protocol discriminator	3	1	M	CMCE
PDU Type	5	1	M	D-FACILITY
Number of SS PDUs	4	1	M	1
Length indicator	11	1	M	147
SS-PDU contents	147	1	C	See next 20 rows
SS type	6	1	M	SS-DGNA
SS-DGNA PDU type	5	1	M	ASSIGN
Number of groups	5	1	M	2 (Group assignments)
Group assignment (first)	82	1	C	See next 15 rows
1 Group SSI	24	1	M	Any
Group extension present	1	1	M	Group extension present
Group extension	24		C	Any
Group identity attachment mode	3	1	M	Any
Optional elements present ?	1	O-bit		1
P-bit for Class of usage element	1	P-bit		1
Class of usage	3	2	O	Any
P-bit for Mnemonic group name element	1	P-bit		1
Mnemonic group name	39	2	O	See next three elements.
Text coding scheme	7	1	M	Latin-1 (8-bit characters)
Length of mnemonic group name character string	8	1	M	24
Mnemonic group name	24		C	"EPT" (= 3 × 8)

Information Element	Length	Type	C/O/M	Value
character string				
P-bit for Length of security related information element	1	P-bit		0
Length of additional group information element	1	P-bit		0
P-bit for (V)GSSI	1	P-bit		0
Group assignment (second)	29	1	C	See next 4 rows
2 Group SSI	24	1	M	Any
Group extension present	1	1	M	No group extension present
Group identity attachment mode	3	1	M	Any
Optional elements present ?	1	O-bit		0 (in this Group assignment)
Acknowledgement requested from affected user(s)	1	1	M	Any
Optional elements present ?	1	O-bit		0 (for SS-DGNA ASSIGN PDU)
Optional elements present ?	1	O-bit		0 (for D-FACILITY PDU)

NOTE: The Mnemonic name encoding requires that the receiving entity is capable to understand the Length of mnemonic group name character string information element. The decoding of the mnemonic name is optional as the length allows to by-pass the name.

**Table E.5: U-INFO PDU with DTMF element**

Information Element	Length	Type	C/O/M	Value
Protocol discriminator	3	1	M	CMCE
PDU Type	5	1	M	U-INFO
Poll response	1	1	M	0
Optional elements present ?	1	O-bit		1
P-bit for Modify element	1	P-bit		0
Type 3 / 4 elements to follow	1	M-bit		1
Type 3/4 element identifier	4	1	M	DTMF
Length indicator	11	1	M	11
DTMF type	3	1	M	DTMF tone start
DTMF digit	4	1	M	1st digit
DTMF digit	4	1	M	2nd digit
Type 3 / 4 elements to follow	1	M-bit		0

**Table E.6: U-STATUS PDU with External subscriber number element**

Information Element	Length	Type	C/O/M	Value
Protocol discriminator	3	1	M	CMCE
PDU Type	5	1	M	U-STATUS
Area selection	4	1	M	Any
Called party type identifier	2	1	M	SSI
Called party SSI	24		C	Any gateway
Pre-coded status	16	1	M	Any
Optional elements present ?	1	O-bit		1
Type 3 / 4 elements to follow	1	M-bit		1
Type 3/4 element identifier	4	1	M	External subscriber number
Length indicator	11	1	M	28
External subscriber number digit	4	1	M	1st digit
External subscriber number digit	4	1	M	2nd digit
External subscriber number digit	4	1	M	3rd digit
External subscriber number digit	4	1	M	4th digit
External subscriber number digit	4	1	M	5th digit
External subscriber number digit	4	1	M	6th digit
External subscriber number digit	4	1	M	7th digit
Type 3 / 4 elements to follow	1	M-bit		0

### E.1.3 PDU encoding examples for MM PDUs

Tables E.6 to E.11 present examples of proper MM PDU encoding in specific cases.

**Table E.7: D-ATTACH/DETACH GROUP IDENTITY PDU**

Information Element	Length	Type	C/O/M	Value
Protocol discriminator	3	1	M	MM
PDU Type	4	1	M	D-ATTACH / DETACH GROUP IDENTITY
Group identity report	1	1	M	No report request
Group identity acknowledgement request	1	1	M	Any
Group identity attach/detach mode	1	1	M	Any
Optional elements present ?	1	O-bit		1
Type 3 / 4 elements to follow	1	M-bit		1
Type 3/4 element identifier	4	1	M	Group identity downlink
Length indicator	11	1	M	67
Number of repeated elements	6	1	M	2
1 Group identity attach/detach type identifier	1	1	M	Attachment
Group identity attachment	5		C	See next 2 rows
Group identity attachment lifetime	2	1	M	Any
Class of usage	3	1	M	Any
Group identity address type	2	1	M	GSSI
GSSI	24		C	Any
2 Group identity attach/detach type identifier	1	1	M	Detachment
Group identity detachment downlink	2		C	Any
Group identity address type	2	1	M	GSSI
GSSI	24		C	Any
Type 3/4 elements to follow ?	1	M-bit		0

**Table E.8: D-LOCATION UPDATE ACCEPT PDU without optional elements**

Information Element	Length	Type	C/O/M	Value
Protocol discriminator	3	1	M	MM
PDU Type	4	1	M	D-LOCATION UPDATE ACCEPT
Location update accept type	3	1	M	Any
Optional elements present ?	1	O-bit		0

Table E.9: D-LOCATION UPDATE ACCEPT PDU with optional Type 4 elements

Information Element	Length	Type	C/O/M	Value
Protocol discriminator	3	1	M	MM
PDU Type	4	1	M	D-LOCATION UPDATE ACCEPT
Location update accept type	3	1	M	Any
Optional elements present ?	1	O-bit		1
P-bit for SSI element	1	P-bit		0
P-bit for Address extension element	1	P-bit		0
P-bit for Subscriber class element	1	P-bit		1
Subscriber class	16	2	O	Any
P-bit for Energy saving information element	1	P-bit		0
P-bit for SCCH information and distribution on 18th frame element	1	P-bit		0
Type 3 / 4 elements to follow	1	M-bit		1
Type 3/4 element identifier	4	1	M	New registered area
Length indicator	11	1	M	42
Number of repeated elements	6	1	M	2
1 LA timer	3	1	M	Any
LA	14	1	M	Any
Optional elements present ?	1	O-bit		0
2 LA timer	3	1	M	Any
LA	14	1	M	Any
Optional elements present ?	1	O-bit		0
Type 3 / 4 elements to follow	1	M-bit		1
Type 3/4 element identifier	4	1	M	Group identity location accept
Length indicator	11	1	M	55
Group identity accept/reject	1	1	M	Any
Reserved	1	1	M	Any
Optional elements present ?	1	O-bit		1
Type 3 / 4 elements to follow	1	M-bit		1
Type 3/4 element identifier	4	1	M	Group identity downlink
Length indicator	11	1	M	35
Number of repeated elements	6	1	M	1
1 Group identity attach/detach type identifier	1	1	M	Detachment
Group identity detachment downlink	2		C	Any
Group identity address type	2	1	M	GSSI
GSSI	24		C	Any
Type 3 / 4 elements to follow ?	1	M-bit		0 (no more elements inside Group identity location accept element)
Type 3 / 4 elements to follow ?	1	m-bit		0 (no more elements in the D-LOCATION UPDATE ACCEPT PDU)

Table E.10: U-LOCATION UPDATE DEMAND PDU without optional elements

Information Element	Length	Type	C/O/M	Value
Protocol discriminator	3	1	M	MM
PDU Type	4	1	M	U-LOCATION UPDATE DEMAND
Location update type	3	1	M	Any
Request to append LA	1	1	M	Any
Cipher control	1	1	M	1
Ciphering parameters	10		C	Any
Optional elements present ?	1	O-bit		0

Table E.11: U-LOCATION UPDATE DEMAND PDU with optional Type 2 elements

Information Element	Length	Type	C/O/M	Value
Protocol discriminator	3	1	M	MM
PDU Type	4	1	M	U-LOCATION UPDATE DEMAND
Location update type	3	1	M	Any
Request to append LA	1	1	M	Any
Cipher control	1	1	M	0
Optional elements present ?	1	O-bit		1
P-bit for Class of MS	1	P-bit		1
Class of MS	24	2	O	Any
P-bit for Energy saving mode	1	P-bit		1
Energy saving mode	3	2	O	Any
P-bit for LA information	1	P-bit		1
Location Area (LA)	14	1		Any
Zero-bit	1	1		0
P-bit for SSI	1	P-bit		0
P-bit for Address extension	1	P-bit		0
Type 3/4 elements present ?	1	M-bit		0

Table E.12: U-LOCATION UPDATE DEMAND PDU with optional Type 4 element

Information Element	Length	Type	C/O/M	Value
Protocol discriminator	3	1	M	MM
PDU Type	4	1	M	U-LOCATION UPDATE DEMAND
Location update type	3	1	M	Any
Request to append LA	1	1	M	Any
Cipher control	1	1	M	0
Optional elements present ?	1	O-bit		1
P-bit for Class of MS	1	P-bit		0
P-bit for Energy saving mode	1	P-bit		0
P-bit for LA information	1	P-bit		0
P-bit for SSI	1	P-bit		0
P-bit for Address extension	1	P-bit		0
Type 3 / 4 elements present ?	1	M-bit		1
Type 3/4 element identifier	4	1	M	Group identity location demand
Length indicator	11	1	M	86
Reserved	1	1	M	Any
Group identity attach/detach mode	1	1	M	Any
Optional elements present ?	1	O-bit		1
Type 3 / 4 elements present	1	M-bit		1
Type 3 / 4 element identifier	4	1	M	Group identity uplink
Length indicator	11	1	M	66
Number of repeated elements	6	1	M	2
1	1	1	M	Attachment
Group identity attach/detach type identifier				
Class of usage	3		C	Any
Group identity address type	2	1	M	GSSI
GSSI	24		C	Any
2	1	1	M	Attachment
Group identity attach/detach type identifier				
Class of usage	3		C	Any
Group identity address type	2	1	M	GSSI
GSSI	24		C	Any
Type 3 / 4 elements to follow?	1	M-bit		0 (no more elements inside Group identity uplink element)
Type 3 / 4 elements to follow?	1	M-bit		0 (no more elements in the U-LOCATION UPDATE DEMAND PDU)

## E.2 PDU encoding rules for MLE PDUs

### E.2.1 General PDU encoding rules for MLE PDUs

The general format of the MLE protocol PDU is defined according to table E.13.

The elements shall be transmitted in the order specified by the table with the top element being transmitted first (before interleaving). The content of an information element is represented by a binary value and the most significant bit of that binary value shall be transmitted first (before interleaving).

**Table E.13: MLE protocol PDU layout**

Information element	Length	Value	Remark
Protocol discriminator	3	101 <sub>2</sub>	Specifies an MLE protocol PDU
PDU type	3		Specifies the particular MLE protocol PDU
Type 1 element (1)			See element definition for length and values
Type 1 element (2)			See element definition for length and values
...etc.			...etc.
Type 1 element (n)			See element definition for length and values
Optional bit (O-bit)	1	0	No type 2 elements follow
		1	Type 2 elements follow
Presence bit (P-bit) (1)	1	0	The type 2 element (1) is not present
		1	The type 2 element (1) is present
Type 2 element (1)			See element definition for length and values
Presence bit (P-bit) (2)	1	0	The type 2 element (2) is not present
		1	The type 2 element (2) is present
Type 2 element (2)			See element definition for length and values
...etc.			...etc.
Presence bit (P-bit) (n)	1	0	The type 2 element (n) is not present
		1	The type 2 element (n) is present
Type 2 element (n)			See element definition for length and values
Conditional element to previous element	varies		See element definition for length and values
...etc.			...etc.
SDU	varies	varies	Encoded as nominated CMCE or MM PDU except protocol discriminator element is not present

#### Presence of O-bit and P-bit:

The O-bit is always present straight after last type 1 element unless stated otherwise in the PDU description. Also when the no type 2 elements are defined for the PDU, the O-bit shall be present and set equal to "0", unless stated otherwise in the PDU description.

In case O-bit has value "0", the PDU contains no type 2 elements; no P-bits for type 2 elements and no type 2 elements.

In case the O-bit has value 1, then at least one type 2 element follows. In this case there is P-bit for each type 2 element which is defined for the PDU; if the type 2 element is present in the PDU then the corresponding P-bit has value 1, if the type 2 element is not present, then the corresponding P-bit has value 0.

NOTE 1: There is no P-bit before an element that is conditional to type 2 element.

NOTE 2: The PDU can contain further information after O-bit even when it is set to value "0"; the PDU can contain an SDU also in case the PDU does not contain any type 2 elements (the O-bit shall be set to "0").

#### Length of the elements:

The length of a type 1 or type 2 element is fixed as indicated in the "Length" column in the PDU. The length of an SDU element or an element conditional to type 2 element may vary.

NOTE 3: A conditional element may also be present in the PDU varying times as indicated by the value of a preceding element to which this element is conditional. In such case the element is marked as "Repeatable" in the PDU.

#### Encoding rules for PDU:

- elements of type 1 are mandatory and shall be placed within the PDU in fixed order as specified in the PDU description tables. The type 1 elements shall be placed before any type 2 elements in the PDU encoding;
- elements of type 2 are optional and shall be placed within the PDU in fixed order as specified in the PDU description tables. In addition the PDU may contain elements that are conditional to type 2 elements; they are present only if the corresponding type 2 element is present and has specified value. These conditional elements are placed after the type 2 element to which they are conditional;
- elements of type SDU are placed as the last element at the end of the PDU. There is no preceding bit for the SDU element, the length of the whole PDU as indicated in the MAC header defines whether the element is present in the PDU or not;

NOTE 4: For presentation purposes a set of information elements can be defined as an information element. The set of information sub-elements may contain also optional or conditional elements and also elements consisting of set of sub-elements. The set is encoded into the PDU as if it were a single information element of the indicated type.

#### The following rules shall apply for decoding of an MLE PDU:

```
DO for all Type 1 elements
  DECODE Type 1 Element
END DO
IF explicitly defined that the PDU shall not contain an O-bit
THEN END of PDU encoding
ELSE
  DECODE O-bit
  IF O-bit set to "Type 2 elements follow"
    DO for all possible type 2 elements
      DECODE P-bit
      IF P-bit set to "Present", decode type 2 element AND
        WHILE conditional element to the type 2 element
          DECODE indicated conditional element
        END WHILE;
    END DO;
  END.
  If SDU present, decode SDU
END.
```

#### The encoding rules for sub-elements:

- in case the PDU information element or sub-element definition contains no "Type" column, the sub-elements of the element/sub-element are all considered to be of type 1.
- type 1 element or type 1 sub-element can contain only type 1 sub-elements;
- type 2 element or type 2 sub-element can contain only type 1 sub-elements;

NOTE 5: As no optional elements are specified for the type 1 or type 2 elements/sub-element, there is no O-bit after the last type 1 sub-element.

- element conditional to type 2 element can contain type 1 and type 2 sub-elements. In case at least one type 2 element is specified for the conditional element, there shall be an O-bit indicating whether the element contains any optional type 2 elements:
  - in case the element contains no optional type 2 elements, the O-bit is set to value "no optional elements follow";
  - in case the element contains optional type 2 element(s), the O-bit is set to value "optional elements follow" and a P-bit shall be set for each type 2 sub-element specified for the conditional element indicating presence of that element. The P-bit shall indicate either "type 2 element present" or "type 2 element not present".



NOTE 6: As no type 3 or type 4 sub-elements are specified for the conditional elements, there shall be no M-bit after the last type 2 element or P-bit indicating that the last optional type 2 element is not present.

**The C/O/M column indicates how the presence of an information element is controlled in the PDU or element/sub-element:**

- M: Mandatory information element is always present (mandatory) in the main PDU level and is always present in a sub-element, when the sub-element itself is present. The type of mandatory element is type 1;
- O: Optional information element may be present in the PDU. The protocol state or an implementation choice defines when it is present or not. The type of optional element is type 2;
- C: Conditional information element is present as defined in the PDU description. The presence depends on the value of another preceding information element. If the information element on which the conditional information element is conditional is not present then also the conditional information element is not present. The conditional information element may be also repeated as many times as indicated by a preceding information element.

## E.2.2 PDU encoding examples for MLE PDUs

Tables E.14 to E.27 present examples of proper MLE PDU encoding in specific cases.

**Table E.14: D-NWRK-BROADCAST PDU with no neighbour cell information elements**

Information Element	Length	Type	C/O/M	Value
Protocol discriminator	3	1	M	MLE
PDU Type	3	1	M	D-NWRK-BROADCAST
Cell re-select parameters	16	1	M	Any
Cell service level	2	1	M	Any
Optional elements present ?	1	O-bit		0

**Table E.15: D-NWRK-BROADCAST PDU with " No neighbour cell information available" indication**

Information Element	Length	Type	C/O/M	Value
Protocol discriminator	3	1	M	MLE
PDU Type	3	1	M	D-NWRK-BROADCAST
Cell re-select parameters	16	1	M	Any
Cell service level	2	1	M	Any
Optional elements present ?	1	O-bit		1
P-bit for TETRA network time element	1	P-bit		0
P-bit for Number of neighbour cells	1	P-bit		1
Number of Neighbour cells element	3	2	O	" No neighbour cell information available"

**Table E.16: D-NWRK-BROADCAST PDU with 2 neighbour cell information elements**

Information Element	Length	Type	C/O/M	Value
Protocol discriminator	3	1	M	MLE
PDU Type	3	1	M	D-NWRK-BROADCAST
Cell re-select parameters	16	1	M	Any
Cell service level	2	1	M	Any
Optional elements present ?	1	O-bit		1
P-bit for TETRA network time element	1	P-bit		0
P-bit for Number of neighbour cells	1	P-bit		1
Number of Neighbour cells element	3	2	O	2
Neighbour cell information (first)	23		C	See next 6 rows
1 Cell identifier	5	1	M	Any except 0
Announced cell reselection types supported	2	1	M	Any
Neighbour cell synchronized	1	1	M	Any
Cell service level	2	1	M	Any
Main carrier number	12	1	M	Any
Optional elements present ?	1	O-bit		0
Neighbour cell information (second)	47		C	See next 17 rows.
2 Cell identifier	5	1	M	Any except 0
Announced cell reselection types supported	2	1	M	Any
Neighbour cell synchronized	1	1	M	Any
Cell service level	2	1	M	Any
Main carrier number	12	1	M	Any
Optional elements present ?	1	O-bit		1
P-bit for Main carrier number extension element	1	P-bit		0
P-bit for MCC element	1	P-bit		0
P-bit for MNC element	1	P-bit		0
P-bit for LA element	1	P-bit		1
LA element	14	2	O	Any
P-bit for Maximum MS transmit power	1	P-bit		0
P-bit for Minimum RX access level	1	P-bit		0
P-bit for Subscriber class	1	P-bit		0
P-bit for BS Service details	1	P-bit		0
P-bit for Timeshare cell information	1	P-bit		0
P-bit for TDMA frame offset	1	P-bit		0

**Table E.17: D-NEW CELL PDU without SDU element**

Information Element	Length	Type	C/O/M	Value
Protocol discriminator	3	1	M	MLE
PDU Type	3	1	M	D-NEW CELL
Channel command valid	2	1	M	Any
Optional elements present ?	1	O-bit		0

**Table E.18: D-NEW CELL PDU with SDU (D-LOCATION UPDATE ACCEPT PDU) element**

Information Element	Length	Type	C/O/M	Value
Protocol discriminator	3	1	M	MLE
PDU Type	3	1	M	D-NEW CELL
Channel command valid	2	1	M	Any
Optional elements present ?	1	O-bit		0
PDU Type	4	1	M	D-LOCATION UPDATE ACCEPT
Location update accept type	3	1	M	Any
Optional elements present ?	1	O-bit		0

**Table E.19: D-PREPARE FAIL PDU without SDU element**

Information Element	Length	Type	C/O/M	Value
Protocol discriminator	3	1	M	MLE
PDU Type	3	1	M	D-PREPARE FAIL
Fail cause	2	1	M	Any
Optional elements present ?	1	O-bit		0

**Table E.20: D-PREPARE FAIL PDU with SDU (D-LOCATION UPDATE REJECT PDU) element**

Information Element	Length	Type	C/O/M	Value
Protocol discriminator	3	1	M	MLE
PDU Type	3	1	M	D-PREPARE FAIL
Fail cause	2	1	M	Any
Optional elements present ?	1	O-bit		0
PDU Type	4	1	M	D-LOCATION UPDATE REJECT
Location update type	3	1	M	Any
Reject cause	5	1	M	Any
Cipher control	1	1	M	0
Optional elements present ?	1	O-bit		0

**Table E.21: D-RESTORE ACK PDU with SDU (D-CALL RESTORE PDU) element**

Information Element	Length	Type	C/O/M	Value
Protocol discriminator	3	1	M	MLE
PDU Type	3	1	M	D-RESTORE ACK
Optional elements present ?	1	O-bit		0
PDU Type	5	1	M	D-CALL RESTORE
Call identifier	14	1	M	Any
Transmission grant	2	1	M	Any
Transmission request permission	1	1	M	Any
Reset call time-out timer (T310)	1	1	M	Any
Optional elements present ?	1	O-bit		0

**Table E.22: D-RESTORE FAIL PDU**

Information Element	Length	Type	C/O/M	Value
Protocol discriminator	3	1	M	MLE
PDU Type	3	1	M	D-RESTORE FAIL
Fail cause	2	1	M	Any
Optional elements present ?	1	O-bit		0

**Table E.23: U-PREPARE PDU without Cell identifier element and without SDU element**

Information Element	Length	Type	C/O/M	Value
Protocol discriminator	3	1	M	MLE
PDU Type	3	1	M	U-PREPARE
Optional elements present ?	1	O-bit		0

**Table E.24: U-PREPARE PDU with Cell identifier element and without SDU element**

Information Element	Length	Type	C/O/M	Value
Protocol discriminator	3	1	M	MLE
PDU Type	3	1	M	U-PREPARE
Optional elements present ?	1	O-bit		1
P-bit for Cell identifier element	1	P-bit		1
Cell identifier	5	2	M	Any

**Table E.25: U-PREPARE PDU with SDU (U-LOCATION UPDATE DEMAND PDU) element**

Information Element	Length	Type	C/O/M	Value
Protocol discriminator	3	1	M	MLE
PDU Type	3	1	M	U-PREPARE
Optional elements present ?	1	O-bit		1
P-bit for Cell identifier element	1	P-bit		1
Cell identifier	5	2	M	Any
PDU Type	4	1	M	U-LOCATION UPDATE DEMAND
Location update type	3	1	M	Call restoration roaming location updating
Request to append LA	1	1	M	Any
Cipher control	1	1	M	0
Optional elements present ?	1	O-bit		1
P-bit for Class of MS	1	P-bit		0
P-bit for Energy saving mode	1	P-bit		1
Energy saving mode	3	2	O	Any
P-bit for LA information	1	P-bit		1
Location area (LA)	14	1	M	Any
Optional elements present ?	1	O-bit		0
P-bit for SSI	1	P-bit		0
P-bit for Address extension	1	P-bit		0
M-bit for Type 3 elements	1	M-bit		0

**Table E.26: U-RESTORE PDU with optional LA element, U-CALL RESTORE PDU does not contain type 3 elements**

Information Element	Length	Type	C/O/M	Value
Protocol discriminator	3	1	M	MLE
PDU Type	3	1	M	U-RESTORE
Optional elements present ?	1	O-bit		1
P-bit for MCC element	1	P-bit		1
P-bit for MNC element	1	P-bit		1
P-bit for LA element	1	P-bit		1
LA element	14	2	O	Any
PDU Type	5	1	M	U-CALL RESTORE
Call identifier	14	1	M	Any
Request to transmit/send data	1	1	M	Any
Other party type identifier	2	1	M	SSI
Other party SSI	24		C	Any
Optional elements present ?	1	O-bit		1
P-bit for Basic service information element	1	P-bit		1
Basic service information element	8	2	M	Any
M-bit (for Type 3 elements)	1	M-bit		0

**Table E.27: U-RESTORE PDU without optional element,  
U-CALL RESTORE PDU contains type 3 element**

Information Element	Length	Type	C/O/M	Value
Protocol discriminator	3	1	M	MLE
PDU Type	3	1	M	U-RESTORE
Optional elements present ?	1	O-bit		0
PDU Type	5	1	M	U-CALL RESTORE
Call identifier	14	1	M	Any
Request to transmit/send data	1	1	M	Any
Other party type identifier	2	1	M	SSI
Other party SSI	24		C	Any
Optional elements present ?	1	O-bit		1
P-bit for Basic service information element	1	P-bit		1
Basic service information element	8	2	M	Any
M-bit (for Type 3 elements)	1	M-bit		1
Type 3 element identifier	4	1	M	Facility or Proprietary
Length indicator	11	1	M	N
Type 3 element	n	1	M	Any
M-bit (for Type 3 elements)	1	M-bit		0

---

## Annex F (normative): TETRA frequency bands, duplex spacings and channel numbering

The usage of the TETRA frequency bands, duplex spacings and channel numbering shall be as defined in TS 100 392-15 [49].

## Annex G (normative): TETRA group management scenarios

TETRA group management scenarios define how group management PDUs shall be encoded in the presented scenarios.

### G.1 General requirements

The requirements are presented as a list to facilitate an easier referencing.

- 1) The structure of the D/U-ATTACH DETACH GROUP IDENTITY PDUs and U/D-ATTACH DETACH GROUP IDENTITY ACK PDUs is defined in clause 16.9 and the PDU encoding in annex E.
  - The in the Group identity uplink element as defined in clause 16.10.15 should have the values as defined in table G.1.

**Table G.1: Group identity uplink information values**

Location scenario	MS location	Group identity address type
1a)	On home system	00 <sub>2</sub>
1b)	On foreign system and SwMI has not previously allocated VGSSI	01 <sub>2</sub>
1c)	On foreign system and SwMI has previously allocated VGSSI (for example, if the MS wishes to detach a group)	10 <sub>2</sub>

- The in the Group identity downlink element as defined in clause 16.10.15 should have the values as defined in table G.2.

**Table G.2: Group identity downlink information values**

Location scenario	MS location	Group identity address type
2a	On home system	00 <sub>2</sub>
2b)	On foreign system (SwMI initiated attachment)	11 <sub>2</sub>
2c) i	On foreign system (response to 1b) above - acceptance of attachment	11 <sub>2</sub>
2c) ii	On foreign system (response to 1b) above - rejection of attachment	01 <sub>2</sub>
2d)	On foreign system (response to 1c) above, same VGSSI)	10 <sub>2</sub>
2e)	On foreign system and the foreign SwMI wishes to allocate a new VGSSI to an existing GTSI which has been allocated a VGSSI (i.e. the new VGSSI replaces the existing VGSSI)	11 <sub>2</sub>
2f)	On foreign system (response to group report, SwMI has previously allocated VGSSI to MS)	11 <sub>2</sub>

- 2) New group attachments/detachments cannot be mixed with the acknowledgements to requested group attachments/detachments contained in the "Group identity location accept" element of the D-LOCATION UPDATE ACCEPT PDU or the D/U-ATTACH / DETACH GROUP IDENTITY ACK PDUs. If the acknowledgement to the group attachment/ detachment request contains a group or a number of groups, those groups shall be the complete set or a subset of the group(s) in the request.
- 3) The "Group identity attach/detach mode" element of the D-ATTACH/DETACH GROUP IDENTITY ACK PDU and the "Group identity attach/detach mode" element of the "Group identity location accept" element of the D-LOCATION UPDATE ACCEPT PDU are to be marked "Reserved".
- 4) The MS shall not reject a SwMI-requested detachment; the SwMI may reject a MS-requested detachment, refer to scenario 5 (7).

- 5) Rejection of attachment is equivalent to acceptance of detachment: the group is detached. Rejection of detachment is equivalent to acceptance of attachment (subject to the restriction described in requirement 4): the group is attached.
- In the following set of rules, "requester" refers to the sender of the D/U-ATTACH DETACH GROUP IDENTITY PDU and "responder" refers to the sender of the U/D-ATTACH DETACH GROUP IDENTITY ACK PDU.
- 6) A value of "0" (Attachment/detachment accepted) in the "Group identity accept/reject" element (D-ATTACH DETACH GROUP IDENTITY ACK PDU) or "Group identity acknowledgement type" element (U-ATTACH DETACH GROUP IDENTITY ACK PDU) indicates to the requester that all the requested attachments and/or detachments have been accepted. All or some of the accepted groups may be present in the Group identity uplink/downlink element of the acknowledgement.

Examples are:

- 6a) Request contains only attachments: all attachments are accepted and the Group identity uplink/downlink element is not present in the acknowledgement.
- 6b) Request contains only attachments: all attachments are accepted, but the Group identity uplink/downlink element in the acknowledgement contains attachment (of some/all groups) indicating a different CoU than the request.
- 6c) Request contains only attachments: all attachments are accepted, but the Group identity uplink/downlink element in the acknowledgement contains attachment (of some/all groups) indicating the attachment lifetime of the group (if different than the default attachment lifetime).
- 6d) Request contains only detachments: all detachments are accepted and the Group identity uplink/downlink element is not present in the acknowledgement.
- 6e) Several attachments and/or detachments in the request: all accepted, Group identity uplink/downlink element is not present in the acknowledgement.
- 6f) Several attachments and/or detachments in the request: all accepted but the Group identity uplink/downlink element in the acknowledgement contains attachment(s) of one or several groups that were requested to be attached, indicating different CoU than the request and/or indicating the attachment lifetime of the group (if different than the default attachment lifetime).

NOTE 1: If a detachment request is accepted, the Group identity uplink/downlink element should not be included in the acknowledgement because it gives the requester no useful information; in fact, the difference in detachment reasons between the request and response may be confusing to the requester.

- 7) A value of 1 (Attachment/detachment rejected) in the "Group identity accept/reject" element (D-ATTACH DETACH GROUP IDENTITY ACK PDU) or "Group identity acknowledgement type" element (U-ATTACH DETACH GROUP IDENTITY ACK PDU) indicates to the requester that at least one of the requested attachments and/or detachments have been rejected. All rejected groups are present in the Group identity uplink/downlink element of the acknowledgement. All or some of the accepted groups may be present in the Group identity uplink/downlink element of the acknowledgement.

Examples are (see proposal 6 for examples of acceptance of attachment/detachment):

- 7a) Request contains only attachments: one or several (maybe even all) attachments are rejected, the Group identity uplink/downlink element is included in the acknowledgement containing the rejected groups and a reject reason for each rejected group.
- 7b) Request contains only detachments: one or several (maybe even all) detachments are rejected, the Group identity uplink/downlink element is included in the acknowledgement containing the rejected groups and attachment information for each rejected group.
- 7c) Request contains attachments and detachments: at least one attachment and/or detachment is rejected, the Group identity uplink/downlink element is included in the acknowledgement containing the rejected group(s) and reject reason/attachment information for each rejected group.



- 8) If the responder accepts a group attachment or detachment request but does not include the group in the response, the responder is said to be implicitly accepting the attachment/detachment request. If the responder accepts or rejects a group attachment or detachment request and does include the group in the response, the responder is said to be explicitly accepting or rejecting the attachment/detachment request:
- 8a) To explicitly accept an attachment, the responder sets the "Group identity attach/detach type identifier" element of the "Group identity uplink" or "Group identity downlink" element to "0" (Attachment).
  - 8b) To explicitly reject an attachment, the responder sets the "Group identity attach/detach type identifier" element of the "Group identity uplink" or "Group identity downlink" element to "1" (Detachment).
  - 8c) To explicitly reject a detachment, the responder sets the "Group identity attach/detach type identifier" element of the "Group identity uplink" or "Group identity downlink" element to "0" (Attachment).
  - 8d) Detachment should not be explicitly accepted - see note 1.

NOTE 2: Implicit rejection of a group attachment or detachment request is not permitted - see requirement 7.

- 9) A MS or a SwMI may request detachment of all groups by sending a group attach/detach request without any groups. For all requests of this nature, with the exception of one solicited by a group report request, the "Group identity attach/detach mode" element shall be set to "1". ("Detach all currently active group identities and attach group identities..."); for a group report request, the "Group identity attach/detach mode" element shall be set to "0" (Amendment).
- 10) If a D/U-ATTACH DETACH GROUP IDENTITY PDU contains at least one detachment request and the "Group identity attach/detach mode" element is set to "1" (Detach all currently active group identities and attach group identities defined in the group identity downlink/uplink element), the responder shall ignore the detachment request(s).

The scenarios in clauses G.2 and G.3 define contents of the group attachment/detachment related information elements of PDUs.

In the scenarios the information contained in the PDU description tables corresponds to the following key:

- [C] desee notes element upon which other elements are conditional (see note that this is not a reference to annex C); and
- CoU = Class of usage.

---

## G.2 MS-INITIATED GROUP ATTACHMENT/DETACHMENT

### G.2.1 SCENARIO 1

MS requests attachment of one group; SwMI accepts attachment, ACK contains group.

#### U-ATTACH DETACH GROUP IDENTITY

- Group identity report = 0 (Not report requested).
- Group identity attach/detach mode = X (Either value).
- Group identity uplink:
  - Group identity attach/detach type identifier = 0 (Attach) [C];
  - CoU = XXX (Any value);
  - Group identity address type = XX (Any value) [C];
  - GSSI/GTSSI/(V)GSSI/GTSSI-(V)GSSI.

#### D-ATTACH DETACH GROUP IDENTITY ACK

- Group identity accept/reject = 0 (Attachment/detachment accepted).
- Group identity attach/detach mode = 0 (Reserved).
- Group identity downlink:
  - Group identity attach/detach type identifier = 0 (Attach) [C];
  - Group identity attachment lifetime = XX (Any value);
  - CoU = XXX (Any value), see note;
  - Group identity address type = see table G.2;
  - GSSI/GTSI/(V)GSSI/GTSI-(V)GSSI = see table G.2.

NOTE: The SwMI may send a different CoU value to that requested by the MS; if the MS does not accept the SwMI CoU, it may send a separate U-ATTACH/DETACH GROUP IDENTITY PDU requesting detachment of the group.

## G.2.2 SCENARIO 2

MS requests attachment of one group; SwMI accepts attachment, ACK does not contain group, see note.

#### U-ATTACH DETACH GROUP IDENTITY

- Group identity report = 0 (Not report requested).
- Group identity attach/detach mode = X (Either value).
- Group identity uplink:
  - Group identity attach/detach type identifier = 0 (Attach) [C];
  - CoU = XXX (Any value);
  - Group identity address type = XX (Any value) [C];
  - GSSI/GTSI/(V)GSSI/GTSI-(V)GSSI.

#### D-ATTACH DETACH GROUP IDENTITY ACK

- Group identity accept/reject = 0 (Attachment/detachment accepted).
- Group identity attach/detach mode = 0 (Reserved).

NOTE: Attachment lifetime of the group is the "default group attachment lifetime"; if the attachment lifetime of the group is different to the default, the group will be present in the ACK PDU, see scenario 1. MS assumes the CoU of the group is the CoU contained in the uplink request.

## G.2.3 SCENARIO 3

MS requests attachment of one group; SwMI rejects attachment, ACK contains group.

#### U-ATTACH DETACH GROUP IDENTITY

- Group identity report = 0 (Not report requested).
- Group identity attach/detach mode = X (Either value).
- Group identity uplink:

- Group identity attach/detach type identifier = 0 (Attach) [C];
- CoU = XXX (Any value);
- Group identity address type = XX (Any value) [C];
- GSSI/GTSI/(V)GSSI/GTSI-(V)GSSI.

#### D-ATTACH DETACH GROUP IDENTITY ACK

- Group identity accept/reject = 1 (Attachment/detachment rejected).
- Group identity attach/detach mode = 0 (Reserved).
- Group identity downlink:
  - Group identity attach/detach type identifier = 1 (Detach) [C];
  - Group identity detachment downlink = XX (Any value);
  - Group identity address type = see table G.2;
  - GSSI/GTSI/(V)GSSI/GTSI-(V)GSSI = see table G.2.

## G.2.4 SCENARIO 4

MS requests detachment of one group; SwMI accepts detachment, ACK does not contain group.

#### U-ATTACH DETACH GROUP IDENTITY

- Group identity report = 0 (Not report requested).
- Group identity attach/detach mode = 0.
- Group identity uplink:
  - Group identity attach/detach type identifier = 1 (Detach) [C];
  - Group identity detachment uplink = XX (Any value);
  - Group identity address type = XX (Any value) [C];
  - GSSI/GTSI/(V)GSSI/GTSI-(V)GSSI.

#### D-ATTACH DETACH GROUP IDENTITY ACK

- Group identity accept/reject = 0 (Attachment/detachment accepted).
- Group identity attach/detach mode = 0 (Reserved).

## G.2.5 SCENARIO 5

MS requests detachment of one group; SwMI rejects detachment, ACK contains group.

#### U-ATTACH DETACH GROUP IDENTITY

- Group identity report = 0 (Not report requested).
- Group identity attach/detach mode = 0.
- Group identity uplink:
  - Group identity attach/detach type identifier = 1 (Detach) [C];

- Group identity detachment uplink = XX (Any value);
- Group identity address type = XX (Any value) [C];
- GSSI/GTSI/(V)GSSI/GTSI-(V)GSSI.

#### D-ATTACH DETACH GROUP IDENTITY ACK

- Group identity accept/reject = 1 (Attachment/detachment rejected).
- Group identity attach/detach mode = 0 (Reserved).
- Group identity downlink:
  - Group identity attach/detach type identifier = 0 (Attach) [C];
  - Group identity attachment lifetime = XX (Any value);
  - CoU = XXX (Any value but probably the value held by the SwMI for this MS/Group combination);
  - Group identity address type = see table G.2;
  - GSSI/GTSI/(V)GSSI/GTSI-(V)GSSI = see table G.2.

## G.2.6 SCENARIO 6

MS requests attachment of multiple groups; SwMI accepts all the attachments, ACK contains all the groups in the uplink request, see note 1.

#### U-ATTACH DETACH GROUP IDENTITY

- Group identity report = 0 (Not report requested).
- Group identity attach/detach mode = X (Either value).
- Group identity uplink {FOR GROUP 1}:
  - Group identity attach/detach type identifier = 0 (Attach) [C];
  - CoU = XXX (Any value);
  - Group identity address type = XX (Any value) [C];
  - GSSI/GTSI/(V)GSSI/GTSI-(V)GSSI.
- Group identity uplink {FOR GROUP 2}:
  - Group identity attach/detach type identifier = 0 (Attach) [C];
  - CoU = XXX (Any value);
  - Group identity address type = XX (Any value) [C];
  - GSSI/GTSI/(V)GSSI/GTSI-(V)GSSI.
- Group identity uplink {FOR GROUP 3}:
  - Group identity attach/detach type identifier = 0 (Attach) [C];
  - CoU = XXX (Any value);
  - Group identity address type = XX (Any value) [C];
  - GSSI/GTSI/(V)GSSI/GTSI-(V)GSSI.

## D-ATTACH DETACH GROUP IDENTITY ACK

- Group identity accept/reject = 0 (Attachment/detachment accepted).
- Group identity attach/detach mode = 0 (Reserved).
- Group identity downlink {FOR GROUP 1}:
  - Group identity attach/detach type identifier = 0 (Attach) [C];
  - Group identity attachment lifetime = XX (Any value);
  - CoU = XXX (Any value) [see note 2];
  - Group identity address type = see table G.2;
  - GSSI/GTSI/(V)GSSI/GTSI-(V)GSSI = see table G.2.
- Group identity downlink {FOR GROUP 2}:
  - Group identity attach/detach type identifier = 0 (Attach) [C];
  - Group identity attachment lifetime = XX (Any value);
  - CoU = XXX (Any value) [see note 2];
  - Group identity address type = see table G.2;
  - GSSI/GTSI/(V)GSSI/GTSI-(V)GSSI = see table G.2.
- Group identity downlink {FOR GROUP 3}:
  - Group identity attach/detach type identifier = 0 (Attach) [C];
  - Group identity attachment lifetime = XX (Any value);
  - CoU = XXX (Any value) [see note 2];
  - Group identity address type = see table G.2;
  - GSSI/GTSI/(V)GSSI/GTSI-(V)GSSI = see table G.2.

NOTE 1: The order of groups in the downlink response does not have to match the order of groups in the uplink request. For example, GROUP 2 followed by GROUP 1 followed by GROUP 3 would be a valid order in the ACK PDU above.

NOTE 2: The SwMI may send a different CoU value to that requested by the MS; if the MS does not accept the SwMI CoU, it may send a separate D-ATTACH DETACH GROUP IDENTITY requesting detachment of the group.

## G.2.7 SCENARIO 7

MS requests attachment of multiple groups; SwMI accepts all the attachments, ACK contains a subset of the groups in the uplink request (see note 1).

### U-ATTACH DETACH GROUP IDENTITY

- Group identity report = 0 (Not report requested).
- Group identity attach/detach mode = X (Either value).
- Group identity uplink {FOR GROUP 1}:
  - Group identity attach/detach type identifier = 0 (Attach) [C];
  - CoU = XXX (Any value);

- Group identity address type = XX (Any value) [C];
- GSSI/GTTSI/(V)GSSI/GTTSI-(V)GSSI.
- Group identity uplink {FOR GROUP 2}:
  - Group identity attach/detach type identifier = 0 (Attach) [C];
  - CoU = XXX (Any value);
  - Group identity address type = XX (Any value) [C];
  - GSSI/GTTSI/(V)GSSI/GTTSI-(V)GSSI.
- Group identity uplink {FOR GROUP 3}:
  - Group identity attach/detach type identifier = 0 (Attach) [C];
  - CoU = XXX (Any value);
  - Group identity address type = XX (Any value) [C];
  - GSSI/GTTSI/(V)GSSI/GTTSI-(V)GSSI.

#### D-ATTACH DETACH GROUP IDENTITY ACK

- Group identity accept/reject = 0 (Attachment/detachment accepted).
- Group identity attach/detach mode = 0 (Reserved).
- Group identity downlink {FOR GROUP 1}:
  - Group identity attach/detach type identifier = 0 (Attach) [C];
  - Group identity attachment lifetime = XX (Any value);
  - CoU = XXX (Any value) [see note 2];
  - Group identity address type = see table G.2;
  - GSSI/GTTSI/(V)GSSI/GTTSI-(V)GSSI = see table G.2.
- Group identity downlink {FOR GROUP 3}:
  - Group identity attach/detach type identifier = 0 (Attach) [C];
  - Group identity attachment lifetime = XX (Any value);
  - CoU = XXX (Any value) [see note 2];
  - Group identity address type = see table G.2;
  - GSSI/GTTSI/(V)GSSI/GTTSI-(V)GSSI = see table G.2.

NOTE 1: Any group contained in the uplink request but not contained in the downlink response (GROUP 2 in this example) is implicitly attached. The attachment lifetime of the group is the "default group attachment lifetime", the MS assumes the CoU of the group is the CoU contained in the uplink request.

NOTE 2: The SwMI may send a different CoU value to that requested by the MS; if the MS does not accept the SwMI CoU, it may send a separate D-ATTACH/DETACH GROUP IDENTITY requesting detachment of the group.

## G.2.8 SCENARIO 8

MS requests attachment of multiple groups; SwMI accepts all the attachments, ACK contains no groups (see note).

### U-ATTACH DETACH GROUP IDENTITY

- Group identity report = 0 (Not report requested).
- Group identity attach/detach mode = X (Either value).
- Group identity uplink {FOR GROUP 1}:
  - Group identity attach/detach type identifier = 0 (Attach) [C];
  - CoU = XXX (Any value);
  - Group identity address type = XX (Any value) [C];
  - GSSI/GTSSI/(V)GSSI/GTSSI-(V)GSSI.
- Group identity uplink {FOR GROUP 2}:
  - Group identity attach/detach type identifier = 0 (Attach) [C];
  - CoU = XXX (Any value);
  - Group identity address type = XX (Any value) [C];
  - GSSI/GTSSI/(V)GSSI/GTSSI-(V)GSSI.
- Group identity uplink {FOR GROUP 3}:
  - Group identity attach/detach type identifier = 0 (Attach) [C];
  - CoU = XXX (Any value);
  - Group identity address type = XX (Any value) [C];
  - GSSI/GTSSI/(V)GSSI/GTSSI-(V)GSSI.

### D-ATTACH DETACH GROUP IDENTITY ACK

- Group identity accept/reject = 0 (Attachment/detachment accepted).
- Group identity attach/detach mode = 0 (Reserved).

NOTE: Attachment lifetime of the groups is the "default group attachment lifetime"; if the attachment lifetime of the group is different to the default, the group will be present in the ACK PDU, see scenario 6 (9). MS assumes the CoU of the group is the CoU contained in the uplink request.

## G.2.9 SCENARIO 9

MS requests attachment of multiple groups; SwMI rejects one of the attachments, ACK contains all the groups in the uplink request (see note).

### U-ATTACH DETACH GROUP IDENTITY

- Group identity report = 0 (Not report requested).
- Group identity attach/detach mode = X (Either value).
- Group identity uplink {FOR GROUP 1}:
  - Group identity attach/detach type identifier = 0 (Attach) [C];
  - CoU = XXX (Any value);
  - Group identity address type = XX (Any value) [C];
  - GSSI/GTSSI/(V)GSSI/GTSSI-(V)GSSI.

- Group identity attach/detach type identifier = 0 (Attach) [C];
- CoU = XXX (Any value);
- Group identity address type = XX (Any value) [C];
- GSSI/GTSI/(V)GSSI/GTSI-(V)GSSI.
- Group identity uplink {FOR GROUP 2}:
  - Group identity attach/detach type identifier = 0 (Attach) [C];
  - CoU = XXX (Any value);
  - Group identity address type = XX (Any value) [C];
  - GSSI/GTSI/(V)GSSI/GTSI-(V)GSSI.
- Group identity uplink {FOR GROUP 3}:
  - Group identity attach/detach type identifier = 0 (Attach) [C];
  - CoU = XXX (Any value);
  - Group identity address type = XX (Any value) [C];
  - GSSI/GTSI/(V)GSSI/GTSI-(V)GSSI.

#### D-ATTACH DETACH GROUP IDENTITY ACK

- Group identity accept/reject = 1 (Attachment/detachment rejected).
- Group identity attach/detach mode = 0 (Reserved).
- Group identity downlink {FOR GROUP 1}:
  - Group identity attach/detach type identifier = 0 (Attach) [C];
  - Group identity attachment lifetime = XX (Any value);
  - CoU = XXX (Any value);
  - Group identity address type = see table G.2;
  - GSSI/GTSI/(V)GSSI/GTSI-(V)GSSI = see table G.2.
- Group identity downlink {FOR GROUP 2}:
  - Group identity attach/detach type identifier = 1 (Detach) [C];
  - Group identity detachment downlink = XX (Any value);
  - Group identity address type = see table G.2;
  - GSSI/GTSI/(V)GSSI/GTSI-(V)GSSI = see table G.2.
- Group identity downlink {FOR GROUP 3}:
  - Group identity attach/detach type identifier = 0 (Attach) [C];
  - Group identity attachment lifetime = XX (Any value);
  - CoU = XXX (Any value);
  - Group identity address type = see table G.2;
  - GSSI/GTSI/(V)GSSI/GTSI-(V)GSSI = see table G.2.



NOTE: Attachment of GROUP 1 and GROUP 3 is explicitly accepted. Attachment of GROUP 2 is explicitly rejected.

## G.2.10 SCENARIO 10

MS requests attachment of multiple groups; SwMI rejects one of the attachments, ACK contains only the rejected group (see note).

### U-ATTACH DETACH GROUP IDENTITY

- Group identity report = 0 (Not report requested).
- Group identity attach/detach mode = X (Either value).
- Group identity uplink {FOR GROUP 1}:
  - Group identity attach/detach type identifier = 0 (Attach) [C];
  - CoU = XXX (Any value);
  - Group identity address type = XX (Any value) [C];
  - GSSI/GTSI/(V)GSSI/GTSI-(V)GSSI.
- Group identity uplink {FOR GROUP 2}:
  - Group identity attach/detach type identifier = 0 (Attach) [C];
  - CoU = XXX (Any value);
  - Group identity address type = XX (Any value) [C];
  - GSSI/GTSI/(V)GSSI/GTSI-(V)GSSI.
- Group identity uplink {FOR GROUP 3}:
  - Group identity attach/detach type identifier = 0 (Attach) [C];
  - CoU = XXX (Any value);
  - Group identity address type = XX (Any value) [C];
  - GSSI/GTSI/(V)GSSI/GTSI-(V)GSSI.

### D-ATTACH DETACH GROUP IDENTITY ACK

- Group identity accept/reject = 1 (Attachment/detachment rejected).
- Group identity attach/detach mode = 0 (Reserved).
- Group identity downlink {FOR GROUP 2}:
  - Group identity attach/detach type identifier = 1 (Detach) [C];
  - Group identity detachment downlink = XX (Any value);
  - Group identity address type = see table G.2;
  - GSSI/GTSI/(V)GSSI/GTSI-(V)GSSI = see table G.2.

NOTE: Attachment of GROUP 1 and GROUP 3 is implicitly accepted. Attachment of GROUP 2 is explicitly rejected.

## G.2.11 SCENARIO 11

MS requests attachment of multiple groups; SwMI rejects all the attachments, ACK contains all the groups in the uplink request (see note).

### U-ATTACH DETACH GROUP IDENTITY

- Group identity report = 0 (Not report requested).
- Group identity attach/detach mode = X (Either value).
- Group identity uplink {FOR GROUP 1}:
  - Group identity attach/detach type identifier = 0 (Attach) [C];
  - CoU = XXX (Any value);
  - Group identity address type = XX (Any value) [C];
  - GSSI/GTTSI/(V)GSSI/GTTSI-(V)GSSI.
- Group identity uplink {FOR GROUP 2}:
  - Group identity attach/detach type identifier = 0 (Attach) [C];
  - CoU = XXX (Any value);
  - Group identity address type = XX (Any value) [C];
  - GSSI/GTTSI/(V)GSSI/GTTSI-(V)GSSI.
- Group identity uplink {FOR GROUP 3}:
  - Group identity attach/detach type identifier = 0 (Attach) [C];
  - CoU = XXX (Any value);
  - Group identity address type = XX (Any value) [C];
  - GSSI/GTTSI/(V)GSSI/GTTSI-(V)GSSI.

### D-ATTACH DETACH GROUP IDENTITY ACK

- Group identity accept/reject = 1 (Attachment/detachment rejected).
- Group identity attach/detach mode = 0 (Reserved).
- Group identity downlink {FOR GROUP 1}:
  - Group identity attach/detach type identifier = 1 (Detach) [C];
  - Group identity detachment downlink = XX (Any value);
  - Group identity address type see table G.2;
  - GSSI/GTTSI/(V)GSSI/GTTSI-(V)GSSI = see table G.2.
- Group identity downlink {FOR GROUP 2}:
  - Group identity attach/detach type identifier = 1 (Detach) [C];
  - Group identity detachment downlink = XX (Any value);
  - Group identity address type = see table G.2;
  - GSSI/GTTSI/(V)GSSI/GTTSI-(V)GSSI = see table G.2.

- Group identity downlink {FOR GROUP 3}:
  - Group identity attach/detach type identifier = 1 (Detach) [C];
  - Group identity detachment downlink = XX (Any value);
  - Group identity address type = see table G.2;
  - GSSI/GTSI/(V)GSSI/GTSI-(V)GSSI = see table G.2.

NOTE: Attachment of all groups is explicitly rejected.

## G.2.12 SCENARIO 12

MS requests attachment of two groups and detachment of one group; SwMI accepts one of the attachments and rejects the detachment and the other attachment, ACK contains all the groups in the uplink request (see note).

### U-ATTACH DETACH GROUP IDENTITY

- Group identity report = 0 (Not report requested).
- Group identity attach/detach mode = 0.
- Group identity uplink {FOR GROUP 1}:
  - Group identity attach/detach type identifier = 0 (Attach) [C];
  - CoU = XXX (Any value);
  - Group identity address type = XX (Any value) [C];
  - GSSI/GTSI/(V)GSSI/GTSI-(V)GSSI.
- Group identity uplink {FOR GROUP 2}:
  - Group identity attach/detach type identifier = 1 (Detach) [C];
  - Group identity detachment uplink = XX (Any value);
  - Group identity address type = XX (Any value) [C];
  - GSSI/GTSI/(V)GSSI/GTSI-(V)GSSI.
- Group identity uplink {FOR GROUP 3}:
  - Group identity attach/detach type identifier = 0 (Attach) [C];
  - CoU = XXX (Any value);
  - Group identity address type = XX (Any value) [C];
  - GSSI/GTSI/(V)GSSI/GTSI-(V)GSSI.

### D-ATTACH DETACH GROUP IDENTITY ACK

- Group identity accept/reject = 1 (Attachment/detachment rejected).
- Group identity attach/detach mode = 0 (Reserved).
- Group identity downlink {FOR GROUP 1}:
  - Group identity attach/detach type identifier = 0 (Attach) [C];
  - Group identity attachment lifetime = XX (Any value);
  - CoU = XXX (Any value);

- Group identity address type = see table G.2;
- GSSI/GTSSI/(V)GSSI/GTSSI-(V)GSSI = see table G.2.
- Group identity downlink {FOR GROUP 2}:
  - Group identity attach/detach type identifier = 0 (Attach) [C];
  - Group identity attachment lifetime = XX (Any value);
  - CoU = XXX (Any value);
  - Group identity address type = see table G.2;
  - GSSI/GTSSI/(V)GSSI/GTSSI-(V)GSSI = see table G.2.
- Group identity downlink {FOR GROUP 3}:
  - Group identity attach/detach type identifier = 1 (Detach) [C];
  - Group identity detachment downlink = XX (Any value);
  - Group identity address type = see table G.2;
  - GSSI/GTSSI/(V)GSSI/GTSSI-(V)GSSI = see table G.2.

NOTE: Attachment of GROUP 1 is explicitly accepted. Detachment of GROUP 2 is explicitly rejected. Attachment of GROUP 3 is explicitly rejected.

## G.2.13 SCENARIO 13

MS requests attachment of two groups and detachment of one group; SwMI accepts one of the attachments and rejects the detachment and the other attachment, ACK contains a subset of the groups in the uplink request (see note).

### U-ATTACH DETACH GROUP IDENTITY

- Group identity report = 0 (Not report requested).
- Group identity attach/detach mode = 0.
- Group identity uplink {FOR GROUP 1}:
  - Group identity attach/detach type identifier = 0 (Attach) [C];
  - CoU = XXX (Any value);
  - Group identity address type = XX (Any value) [C];
  - GSSI/GTSSI/(V)GSSI/GTSSI-(V)GSSI.
- Group identity uplink {FOR GROUP 2}:
  - Group identity attach/detach type identifier = 1 (Detach) [C];
  - Group identity detachment uplink = XX (Any value);
  - Group identity address type = XX (Any value) [C];
  - GSSI/GTSSI/(V)GSSI/GTSSI-(V)GSSI.
- Group identity uplink {FOR GROUP 3}:
  - Group identity attach/detach type identifier = 0 (Attach) [C];
  - CoU = XXX (Any value);

- Group identity address type = XX (Any value) [C];
- GSSI/GTSI/(V)GSSI/GTSI-(V)GSSI.

#### D-ATTACH DETACH GROUP IDENTITY ACK

- Group identity accept/reject = 1 (Attachment/detachment rejected).
- Group identity attach/detach mode = 0 (Reserved).
- Group identity downlink {FOR GROUP 2}:
  - Group identity attach/detach type identifier = 0 (Attach) [C];
  - Group identity attachment lifetime = XX (Any value);
  - CoU = XXX (Any value);
  - Group identity address type = see table G.2;
  - GSSI/GTSI/(V)GSSI/GTSI-(V)GSSI = see table G.2.
- Group identity downlink {FOR GROUP 3}:
  - Group identity attach/detach type identifier = 1 (Detach) [C];
  - Group identity detachment downlink = XX (Any value);
  - Group identity address type = see table G.2;
  - GSSI/GTSI/(V)GSSI/GTSI-(V)GSSI = see table G.2.

NOTE: Attachment of GROUP 1 is implicitly accepted. Detachment of GROUP 2 is explicitly rejected. Attachment of GROUP 3 is explicitly rejected.

---

## G.3 SwMI-INITIATED GROUP ATTACHMENT/DETACHMENT

The principles of SwMI-initiated group attachment/detachment are the same as those for MS-initiated group attachment/detachment with the following exceptions:

- 1) The PDU exchange is D-ATTACH DETACH GROUP IDENTITY / U-ATTACH DETACH GROUP IDENTITY ACK.
- 2) The "Group identity accept/reject" element in the SwMI ACK becomes a "Group identity acknowledgement type" element in the MS ACK (the bit orientation and the meaning of the bit values is identical between the two elements).
- 3) The SwMI may request that the MS does not send an ACK (via "Group identity acknowledgement request" element in the D-ATTACH DETACH GROUP IDENTITY PDU). If the MS wishes to reject a SwMI-initiated attachment or detachment but is prevented from sending an ACK by the SwMI, the MS may initiate a separate U-ATTACH DETACH GROUP IDENTITY / D-ATTACH DETACH GROUP IDENTITY ACK PDUs transaction with the SwMI.
- 4) The U-ATTACH DETACH GROUP IDENTITY ACK PDU does not contain a "Group identity attach/detach mode" element (refer to proposal 3).
- 5) SwMI requests attachment/detachment with the "Group identity downlink" element; MS requests attachment / detachment with the "Group identity uplink" element. SwMI ACKs attachment / detachment with the "Group identity downlink" element; MS ACKs attachment / detachment with the "Group identity uplink" element.

- 6) The MS may send a different CoU value in the ACK to that requested by the SwMI. If the SwMI does not accept the MS CoU, it may send a separate D-ATTACH / DETACH GROUP IDENTITY PDU enforcing detachment of the group, refer to see note 1 of scenario 1.
- 7) The MS cannot reject a SwMI-requested group detachment (refer to proposal 4).

## Annex H (normative): TETRA proprietary information element owner

This annex defines TETRA proprietary information element owner.

### H.1 Proprietary information element

TETRA protocols for CMCE and MM contain optional proprietary information elements. In order to identify and differentiate various implementations of the proprietary elements an proprietary element owner is defined as the first information element of the proprietary element, refer to clauses 14.8.35 and 16.10.41.

The proprietary element owner information element shall contain elements as defined in table H.1.

**Table H.1: Proprietary element owner contents**

Information element	Length	Type	C/O/M	Value	Remark
Proprietary element owner	8	1	M	00000000 <sub>2</sub>	Extension indicator, see note 1
				00000001 <sub>2</sub>	Owner 1
				etc.	etc.
				11111111 <sub>2</sub>	Owner 255
Proprietary element owner extension	Reserved	1	C	All values reserved	see note 2
NOTE 1: This value shall indicate that the proprietary element owner is indicated by the proprietary element owner extension information element. This value is not used in the edition 2 of the present document.					
NOTE 2: This information element shall be present only when the proprietary element owner information element has the value 00000000 <sub>2</sub> . This information element is not used in the edition 2 of the present document.					

The proprietary element owner values are managed by a central body.

Each manufacture should have only a single value of the proprietary element owner information element. The manufacture should design his proprietary information element contents so that he can use the same proprietary element owner value for various purposes. It is recommended that the proprietary information part is coded so that it contains in the beginning a protocol identifier, a PDU type or an information element type managed by that manufacturer so that the usage of the single proprietary element owner value can be continued as long as possible.

It is allowed that multiple manufacturers use the same proprietary element owner value under responsibility of the registered owner.

### H.2 Application for the proprietary element owner value

This application form is provided under assumption that ETSI will be the central body for the management of the proprietary element owner values of the edition 2 of the present document. The application and allocation may be implemented by other means such as a World Wide Web server application.

**PROVISION OF AND RESTRICTED USAGE UNDERTAKING**

relating to

a **proprietary element owner** information element value, to be used in mobile and line stations and in TETRA SwMIs for Terrestrial Trunked Radio (TETRA) systems.

Between

(COMPANY NAME) .....

(COMPANY ADDRESS) .....

hereinafter called: the **BENEFICIARY**;

and

(COMPANY NAME).....European Telecommunications Standards Institute

(COMPANY ADDRESS).....06921 Sophia Antipolis CEDEX, France

hereinafter called: the **PROVIDER**.

- Whereas

The **BENEFICIARY** has alleged that he fulfils the following criteria:

- He is a manufacturer of TETRA equipment.

The **PROVIDER** undertakes to give to the **BENEFICIARY**:

- One globally unique **proprietary element owner** information element value, registered by the **PROVIDER**.

The provided **proprietary element owner** information element value is filled in below by the **PROVIDER** when he has received and approved two signed originals of this agreement.

**Proprietary element owner:**

Decimal number

=

Binary number

The code above is given as a decimal (1 to 255) number, and as a 8 bit binary number (00000001<sub>2</sub> to 11111111<sub>2</sub>). The most significant digit and bit are positioned to the left.



The BENEFCIARY undertakes:

1. To apply and use the **proprietary element owner** value in accordance with rules in annex H of the present document.
2. To return the **proprietary element owner** value to the PROVIDER, within 5 years, if these has not been used.

EN 300 392-2: "Terrestrial Trunked Radio (TETRA); Voice plus Data (V+D); Part 2: Air Interface (AI)", annex H.

In case the BENEFCIARY violates any of the obligations incurred on him by the present undertaking, he shall be liable of indemnifying ETSI for all losses suffered directly or through claims from legitimate TETRA users.

All disputes which derive from the present undertaking or its interpretation shall be settled by the Court of Arbitration of the International Chamber of Commerce situated in Paris, in accordance with the procedures of this Court of Arbitration and with the application of French Law regarding questions of interpretation.

Made in two originals, one of which is for the PROVIDER, the other for the BENEFCIARY; both originals signed by a legal representative of his company/organization.

For the PROVIDER

For the BENEFCIARY

(signed) .....

(Name, Title (typed)) .....

.....

(signed) .....

(Name, Title (typed)) .....

.....

K H Rosenbrock, Director General

(Date)

(Date)

---

Annex I (normative):  
Void

## Annex J (normative): TETRA SDS-TL protocol identifier information element owner

This annex defines TETRA SDS-TL protocol identifier information element owner.

### J.1 Protocol identifier information element

TETRA SDS-TL in clause 29.4.3.9 defines protocol identifiers for various SDS-TL protocols. Some of the potential protocols are defined in the SDS-TL standard in clause 29 and some protocol will be defined independently of the clause 29. In order to identify the manufacturer specific protocols the protocol identifiers are allocated by a central body. The manufacturer means in this context either a TETRA equipment manufacturer or a TETRA application designer.

There are two ranges on protocol identifiers available for the manufacturer specific protocols as defined in the clause 29.4.3.9 and copied in a short form into table J.1.

**Table J.1: SDS-TL protocol identifier information element contents**

Information element	Length	Type	C/O/M	Value	Remark
Protocol identifier	8	1	M	01000000 <sub>2</sub> to 01111111 <sub>2</sub>	The SDS-TL protocol PDUs are not used (see note 1).
				11000000 <sub>2</sub> to 11111111 <sub>2</sub>	The SDS-TL protocol PDUs are used (see note 2).
				All other values	These values are outside the scope of this annex.
NOTE 1: For these values each SDS type 4 user data information element contains as the standardized part the protocol identifier as the first 8 bits. The rest of the user data information is outside the scope of the present document.					
NOTE 2: For these values each SDS type 4 user data information element contains as the standardized part one of the SDS-TL PDUs as defined in clause 29.4.2. The SDS-TL PDUs contain as the first information element the protocol identifier.					

The protocol identifier values are managed by a central body.

Each manufacture may have multiple values of the protocol identifier information element. The manufacture should design his proprietary information element contents so that he can use the same protocol identifier value for all purposes of a protocol. It is recommended that the manufacturer specific protocol information part is coded so that it contains in the beginning a PDU type or an information element type managed by that manufacturer so that the usage of the single protocol identifier value can be used for all purposes for that protocol. The same protocol identifier value may be used for various protocols if suitable on the manufacturers point of view.

It is allowed that multiple manufacturers or application designers use the same protocol identifier value under responsibility of the registered owner.

### J.2 Application for the protocol identifier value

This application form is provided under assumption that ETSI will be the central body for the management of the SDS-TL protocol identifier owner values of the present document. The application and allocation may be implemented by other means such as a World Wide Web server application.

**PROVISION OF AND RESTRICTED USAGE UNDERTAKING**

relating to

a SDS-TL **protocol identifier** information element value, to be used in mobile and line stations, in application using TETRA equipment and in TETRA SwMIs for Terrestrial Trunked Radio (TETRA) systems.

Between

(COMPANY NAME) .....

(COMPANY ADDRESS) .....

hereinafter called: the BENEFICIARY;

and

(COMPANY NAME).....European Telecommunications Standards Institute

(COMPANY ADDRESS).....06921 Sophia Antipolis CEDEX, France

hereinafter called: the PROVIDER.

- Whereas

The BENEFICIARY has alleged that he fulfils the following criteria:

- He is a manufacturer of TETRA equipment.

The PROVIDER undertakes to give to the BENEFICIARY:

- One globally unique SDS-TL **protocol identifier** information element value, registered by the PROVIDER.

The provided SDS-TL **protocol identifier** information element value is filled in below by the PROVIDER when he has received and approved two signed originals of this agreement.

SDS-TL **protocol identifier**:  =   
 Decimal number  Binary number

The code above is given as a decimal (64 to 127 or 192 to 255) number, and as a 8 bit binary number (01000000<sub>2</sub> to 01111111<sub>2</sub>.or 11000000<sub>2</sub> to 11111111<sub>2</sub>). The most significant digit and bit are positioned to the left.

The BENEFCIARY undertakes:

1. To apply and use the SDS-TL **protocol identifier** value in accordance with rules in annex J of the present document.
2. To return the SDS-TL **protocol identifier** value to the PROVIDER, within 5 years, if these has not been used.

EN 300 392-2: "Terrestrial Trunked Radio (TETRA); Voice plus Data (V+D); Part 2: Air Interface (AI)", annex J.

In case the BENEFCIARY violates any of the obligations incurred on him by the present undertaking, he shall be liable of indemnifying ETSI for all losses suffered directly or through claims from legitimate TETRA users.

All disputes which derive from the present undertaking or its interpretation shall be settled by the Court of Arbitration of the International Chamber of Commerce situated in Paris, in accordance with the procedures of this Court of Arbitration and with the application of French Law regarding questions of interpretation.

Made in two originals, one of which is for the PROVIDER, the other for the BENEFCIARY; both originals signed by a legal representative of his company/organization.

For the PROVIDER

For the BENEFCIARY

(signed) .....

(Name, Title (typed)) .....

.....

(signed) .....

K H Rosenbrock, Director General

(Name, Title (typed)) .....

.....

(Date)

(Date)

## Annex K (informative): TETRA Mobile Country Code information element values

This annex lists the provisionally allocated values for the TETRA Mobile Country Code information element.

### K.1 Management of TETRA Mobile Country Codes

A central body will manage TETRA Mobile Country Codes in contrary what is defined in edition 1 of EN 300 392-1 [9] clause 7.2.5. This central body may be TETRA MoU, refer to [www.tetramou.com](http://www.tetramou.com), or ITU-T, refer to [www.itu.int](http://www.itu.int).

### K.2 TETRA Mobile Country Code information element values

Table K.1 lists the provisional TETRA Mobile Country Code information element values. The central body may modify the table at any time without a need to update the table K.1 in the present document each time there is a change.

**Table K.1: TETRA Mobile Country Codes for Global Use**

Country or Geographical Area	Code
Greece	202
Netherlands (Kingdom of the)	204
Belgian	206
France	208
Monaco (Principality of)	212
Andorra (Principality of)	213
Spain	214
Hungary (Republic of)	216
Bosnia and Herzegovina (Republic of)	218
Croatia (Republic of)	219
Yugoslavia (Federal Republic of)	220
Italy	222
Vatican City State	225
Romania	226
Switzerland (Confederation of)	228
Czech Republic	230
Slovak Republic	231
Austria	232
United Kingdom of Great Britain and Northern Ireland	234
Denmark	238
Sweden	240
Norway	242
Finland	244
Lithuania (Republic of)	246
Latvia (Republic of)	247
Estonia (Republic of)	248
Russian Federation	250
Ukraine	255
Belarus (Republic of)	257
Moldova (Republic of)	259
Poland	260
Germany (Federal Republic of)	262
Gibraltar	266
Portugal	268
Luxembourg	270
Ireland	272
Iceland	274

Country or Geographical Area	Code
Albania (Republic of)	276
Malta	278
Cyprus (Republic of)	280
Georgia	282
Armenia (Republic of)	283
Bulgaria (Republic of)	284
Turkey	286
Faroe Islands	288
Greenland	290
San Marino (Republic of)	292
Slovenia (Republic of)	293
The Former Yugoslav Republic of Macedonia	294
Liechtenstein (Principality of)	295
Canada	302
Saint Pierre and Miquelon (Collectivité territoriale de la République française)	308
United States of America	310
Puerto Rico	330
United States Virgin Islands	332
Mexico	334
Jamaica	338
Guadeloupe (French Department of) and Martinique (French Department of)	340
Barbados	342
Antigua and Barbuda	344
Cayman Islands	346
British Virgin Islands	348
Bermuda	350
Grenada	352
Montserrat	354
Saint Kitts and Nevis	356
Saint Lucia	358
Saint Vincent and the Grenadines	360
Netherlands Antilles	362
Aruba	363
Bahamas (Commonwealth of the)	364
Anguilla	365
Dominica (Commonwealth of)	366
Cuba	368
Dominican Republic	370
Haiti (Republic of)	372
Trinidad and Tobago	374
Turks and Caicos Islands	376
Azerbaijani Republic	400
Kazakhstan (Republic of)	401
India (Republic of)	404
Pakistan (Islamic Republic of)	410
Afghanistan (Islamic State of)	412
Sri Lanka (Democratic Socialist Republic of)	413
Myanmar (Union of)	414
Lebanon	415
Jordan (Hashemite Kingdom of)	416
Syrian Arab Republic	417
Iraq (Republic of)	418
Kuwait (State of)	419
Saudi Arabia (Kingdom of)	420
Yemen (Republic of)	421
Oman (Sultanate of)	422
United Arab Emirates	424
Israel (State of)	425
Bahrain (State of)	426
Qatar (State of)	427
Mongolia	428

Country or Geographical Area	Code
Nepal	429
United Arab Emirates (Abu Dhabi)	430
United Arab Emirates (Dubai)	431
Iran (Islamic Republic of)	432
Uzbekistan (Republic of)	434
Tajikistan (Republic of)	436
Kyrgyz Republic	437
Turkmenistan	438
Japan	440
Korea (Republic of)	450
Viet Nam (Socialist Republic of)	452
Hong Kong	454
Macau	455
Cambodia (Kingdom of)	456
Lao People's Democratic Republic	457
China (People's Republic of)	460
Taiwan, China	466
Democratic People's Republic of Korea	467
Bangladesh (People's Republic of)	470
Maldives (Republic of)	472
Korea (Republic of)	480
Malaysia	502
Australia	505
Indonesia (Republic of)	510
Philippines (Republic of the)	515
Thailand	520
Singapore (Republic of)	525
Brunei Darussalam	528
New Zealand	530
Northern Mariana Islands (Commonwealth of the)	534
Guam	535
Nauru (Republic of)	536
Papua New Guinea	537
Tonga (Kingdom of)	539
Solomon Islands	540
Vanuatu (Republic of)	541
Fiji (Republic of)	542
Wallis and Futuna (French Overseas Territory)	543
American Samoa	544
Kiribati (Republic of)	545
New Caledonia (French Overseas Territory)	546
French Polynesia (French Overseas Territory)	547
Cook Islands	548
Western Samoa (Independent State of)	549
Micronesia (Federated States of)	550
Egypt (Arab Republic of)	602
Algeria (People's Democratic Republic of)	603
Morocco (Kingdom of)	604
Tunisia	605
Libya (Socialist People's Libyan Arab Jamahiriya)	606
Gambia (Republic of the)	607
Senegal (Republic of)	608
Mauritania (Islamic Republic of)	609
Mali (Republic of)	610
Guinea (Republic of)	611
Côte d'Ivoire (Republic of)	612
Burkina Faso	613
Niger (Republic of the)	614
Togolese Republic	615
Benin (Republic of)	616
Mauritius (Republic of)	617
Liberia (Republic of)	618
Sierra Leone	619



Country or Geographical Area	Code
Ghana	620
Nigeria (Federal Republic of)	621
Chad (Republic of)	622
Central African Republic	623
Cameroon (Republic of)	624
Cape Verde (Republic of)	625
Sao Tome and Principe (Democratic Republic of)	626
Equatorial Guinea (Republic of)	627
Gabonese Republic	628
Congo (Republic of the)	629
Zaire (Republic of)	630
Angola (Republic of)	631
Guinea-Bissau (Republic of)	632
Seychelles (Republic of)	633
Sudan (Republic of the)	634
Rwandese Republic	635
Ethiopia (Federal Democratic Republic of)	636
Somali Democratic Republic	637
Djibouti (Republic of)	638
Kenya (Republic of)	639
Tanzania (United Republic of)	640
Uganda (Republic of)	641
Burundi (Republic of)	642
Mozambique (Republic of)	643
Zambia (Republic of)	645
Madagascar (Republic of)	646
Reunion (French Department of)	647
Zimbabwe (Republic of)	648
Namibia (Republic of)	649
Malawi	650
Lesotho (Kingdom of)	651
Botswana (Republic of)	652
Swaziland (Kingdom of)	653
Comoros (Islamic Federal Republic of the)	654
South Africa (Republic of)	655
Belize	702
Guatemala (Republic of)	704
El Salvador (Republic of)	706
Honduras (Republic of)	708
Nicaragua	710
Costa Rica	712
Panama (Republic of)	714
Peru	716
Argentine Republic	722
Brazil (Federative Republic of)	724
Chile	730
Colombia (Republic of)	732
Venezuela (Republic of)	734
Bolivia (Republic of)	736
Guyana	738
Ecuador	740
Guiana (French Department of)	742
Paraguay (Republic of)	744
Suriname (Republic of)	746
Uruguay (Eastern Republic of)	748

---

## Annex L (informative): Bibliography

- TETRA MoU SFPG Recommendation 07 - End-to-End Encrypted Short Data Service, <http://www.tetramou.com/members/sfpg/index.asp>
- CEPT Recommendation T/CS 46-02 E: "Multifrequency Signalling System to be Used for Push-Button Telephones".
- Digital Land Mobile Radiocommunications, M. Failli (Ed.), Final Report 14.3.1984-13.9.1988, published by European Commission, Directorate of General Telecommunication, Information Industries and Innovation. Luxembourg. ISBN 92-825-9946-9. (1989)
- ETS 300 392-2 edition 1: "Terrestrial Trunked Radio (TETRA); Voice plus Data (V+D); Part 2: Air Interface (AI)".
- EN 300 392-2: "Terrestrial Trunked Radio (TETRA); Voice plus Data (V+D); Part 2: Air Interface (AI)".

## Annex M (Informative): Change Requests

The present document includes Change Requests as presented in table M.1. Italic text indicates CRs that were already included into version V2.3.2 or are not applicable to the next to be published version V2.4.1.

**Table M.1: List of Change Requests**

No	CR vers.	Version	Clauses affected	Title	CR Status
001	APP	V2.1.1	28.4.4.1, 28.4.4.2, 28.4.4.3, 28.4.5.2	<i>Access point name index size</i>	<i>EPT Approved 2000</i>
<b>002</b>	APPi	V2.3.2	17.3.5, 17.3.6, 17.3.9, 18.2.4, 18.2.8, 20.2.4, 20.3.4, 20.3.5.1, 22.1.2, 22.2.2.3, 22.2.2.5, 22.2.2.7, 22.3.3.2.2, 22.3.3.2.7, 28.2.4.7, 28.2.6.2 and annex A.1	READY timer enhancement	EPT approved 011121
<b>003</b>	APP	V2.3.1	29.5.4.2	Text Character Encoding and Packing for 7, 8 and 16-bit Alphabet	EPT approved 010305
004	APP	V2.3.1	29.4.3.9	<i>Error in see note reference</i>	<i>EPT approved 010305</i>
<b>005</b>	APP	V2.3.1	16.10.5 Table 167	Clarification of Concurrent Channel in Class of MS	EPT approved 010419
<b>006</b>	APP	V2.3.1	14.4.2 Figure 22	Acceptance of D_INFO in CC WAIT state	EPT approved 010305
<b>007</b>	APP	V2.3.1	21.4.4.1	Additional bit required for Security Information ("GCK Supported") for use in 392-7	EPT approved 010419
<b>008</b>	APP	V2.3.1	28.2.4.5, 28.2.4.8, Figure 184 and Table 365	Migration of Packet Data Mobile	EPT approved 010419
009	REJ	V2.3.1	28.2.5a	Mismatch of subscriber class	Rejected
<b>010</b>	APPi2	V2.3.1	28.3.6, 28.4.1, 28.4.4.3, 28.4.5.10, 28.4.5.38 and 28.4.5.45	Correction of typographical errors and minor omissions	EPT approved 010419
<b>011</b>	APPi	V2.3.2	28.2.4.4, 28.2.4.7, 28.4.4.9, 28.5	Use of Immediate service change element on downlink	EPT approved 011121
012	REJ	V2.3.1	16.4, 16.9, 16.10	SwMI Capabilities	Withdrawn
013	REJ	V2.3.1	21.4.4.1	Additional bit required for Security Information ("Short GCK-VN") for use in 392-7	Rejected
014	REJ	V2.3.1	14.5.6.2	PDU Priority for U-INFO	Rejected
015	Comb	V2.3.1	11.3.4, 14.8.18	New additional disconnect cause	Combined with CR021
<b>016</b>	APP	V2.3.1	28.3.3.4	Clarification to Packet Data MS type	EPT approved 010629
<b>017</b>	APP	V2.3.1	annex C	Correction to CRC calculation algorithm	EPT approved 010629
018		V2.3.1			
019	Comb	V2.3.1	11.3.4, 14.8.18	New additional disconnect cause	Combined with CR021
<b>020</b>	APP	V2.3.2	28.4.4.1 and 28.4.4.3	Access point name index element on downlink	EPT approved 011121
<b>021</b>	APP	V2.3.1	14.8.18	New disconnect causes	EPT approved 011121
022	REJ	V2.3.1	14.8.18	New disconnect cause; Unknown number	Withdrawn

023	REJ	V2.3.2	16	Subscriber class	Rejected
024	APPi2	V2.3.2	11.3.4, 14.5.1.1.5, 14.8.18	DCOMP negotiation element	EPT approved 011121
025	APP	V2.3.2	29.4.3.9	SDS-TL Protocol IDs for encryption	EPT approved 020130
026	APP	V2.3.2	18.5.17	Note on Timeshare cell and AI encryption element	EPT approved 011121
027	APP	V2.3.2	16.4.11, 16.9.2.5.9, 16.10.7b, 16.10.7c, 17.3.1, 17.3.2, 17.3.9, 20.3.5.4.1, 20.4.1.1.4 and 20.2.4.29a	Periodic distance reporting MM-STATUS PDU	EPT approved 020130
028	APP	V2.3.2	28.3.3.4	Packet data MS type	EPT approved 030307
029	APP	V2.3.2	16.11.1.1	Registration timer T351	EPT approved 030307
030	APP	V2.3.2	14.6	Call restoration timer T307 (P2MP)	EPT approved 030307
031	APP	V2.3.2	29.5.2, 29.5.3 and 29.4.3.9	Reservation of Protocol Identifiers for Immediate Text messaging	EPT approved 030307
032	APP	V2.3.2	16.10.5 (Table 167)	Errors in references to ETS 300 392-2 and EN 300 392-2	EPT approved 030307
033	APP	V2.3.2	21.4.4.2 (Table 335)	Errors in references to EN 300 392-2 and ETS/EN 300 392-7 [11]	EPT approved 030307
034	APP	V2.3.2	29.4.3.9	SDS-TL PID for OTAR should be for OTAK for End to End Encryption Key Delivery	EPT approved 030307
035	APP	V2.3.2	29.5.4.1	Mistake in the referred clause number 29.5.4.3	EPT approved 030307
036	APP	V2.3.2	9.4.4.3.6	Phase adjustment bits and n2 value	EPT approved 030307
037	APP	V2.3.2	23.3.1.2.1	Expand description of common SCCH configuration changes on BNCH	EPT approved 030307
038	APP	V2.3.2	14.5.6b, 17.3.1, 17.3.2, 17.3.5, 17.3.6, 17.3.9, 23.7.6, 28.2.4.4, 28.2.4.6, 28.2.4.7, 28.2.4.8	Improve call set-up phase response for mobiles using Energy Economy Group	EPT approved 030307
039	APP	V2.3.2	29.4.3.2	Correction of the report source	EPT approved 030307
040	APP	V2.3.2	29.3.3.6.3, 29.4.3.2	Modification of the report reason "Destination not reachable, message stored by SwMI"	EPT approved 030307
041	APP	V2.3.2	28.4.5.28	Update to PCOMP negotiation table	EPT approved 030307
042	APP	V2.3.2	28.4.5.9	BSD compression and uncompressed data	EPT approved 030307
043	APP	V2.3.2	28.3.5.4.2, 28.3.5.4.3, 28.3.5.4.4	Clarification over data compression	EPT approved 030307
044	APP	V2.3.2	14.8.34	Typo in 14.8.34 Pre-coded status	EPT approved 030307
045	1.0	V.2.3.2	6.6.2.3	Change in 6.6.2.3 Receiver performance at reference interference ratios	WG3 approved 030328
046	1.0	V2.3.2	21.4.4.2	Change of System Code in V+D to give 1 bit to DMO for 2 additional values	WG3 approved 030328
047				Path loss parameter C1	Rejected
048	1.0	V2.3.2	18.3.4.7.5	Error in reference to EN 300 392-7 [11]	WG3 approved 030408
049	1.0	V2.3.2	annex K.2	Change of Hong Kong country code	Information
050	1.2	V2.3.2	18.5.24	TETRA System Time bits	WG3 approved 030603
051	1.0	V2.3.2	3.1	Further editorial corrections	WG3 approved 030603
052	1.0	V2.3.2	29.4.3.9	SDS-TL PID extension	WG3 approved 030603
053					

---

## History

<b>Document history</b>		
Edition 1	March 1996	Publication as ETS 300 392-2
V2.1.1	December 2000	Publication
V2.1.1	December 2000	Publication as EN 300 392-2
V2.2.1	September 2000	Publication (Withdrawn)
V2.3.1	November 2000	Publication
V2.3.2	March 2001	Publication as EN 300 392-2
V2.4.1	October 2003	One-step Approval Procedure      OAP 20040220: 2003-10-22 to 2004-02-20
V2.4.1	October 2003	Publication