

# ETSI TR 137 985 V17.1.1 (2022-04)



**LTE;  
5G;**

**Overall description of Radio Access Network (RAN)  
aspects for Vehicle-to-everything (V2X) based on LTE and NR  
(3GPP TR 37.985 version 17.1.1 Release 17)**



---

**Reference**

RTR/TSGR-0137985vh11

---

**Keywords**

5G,LTE

**ETSI**

650 Route des Lucioles  
F-06921 Sophia Antipolis Cedex - FRANCE

---

Tel.: +33 4 92 94 42 00 Fax: +33 4 93 65 47 16

Siret N° 348 623 562 00017 - APE 7112B  
Association à but non lucratif enregistrée à la  
Sous-Préfecture de Grasse (06) N° w061004871

---

**Important notice**

The present document can be downloaded from:

<http://www.etsi.org/standards-search>

The present document may be made available in electronic versions and/or in print. The content of any electronic and/or print versions of the present document shall not be modified without the prior written authorization of ETSI. In case of any existing or perceived difference in contents between such versions and/or in print, the prevailing version of an ETSI deliverable is the one made publicly available in PDF format at [www.etsi.org/deliver](http://www.etsi.org/deliver).

Users of the present document should be aware that the document may be subject to revision or change of status.

Information on the current status of this and other ETSI documents is available at

<https://portal.etsi.org/TB/ETSIDeliverableStatus.aspx>

If you find errors in the present document, please send your comment to one of the following services:

<https://portal.etsi.org/People/CommitteeSupportStaff.aspx>

If you find a security vulnerability in the present document, please report it through our  
Coordinated Vulnerability Disclosure Program:

<https://www.etsi.org/standards/coordinated-vulnerability-disclosure>

---

**Notice of disclaimer & limitation of liability**

The information provided in the present deliverable is directed solely to professionals who have the appropriate degree of experience to understand and interpret its content in accordance with generally accepted engineering or other professional standard and applicable regulations.

No recommendation as to products and services or vendors is made or should be implied.

No representation or warranty is made that this deliverable is technically accurate or sufficient or conforms to any law and/or governmental rule and/or regulation and further, no representation or warranty is made of merchantability or fitness for any particular purpose or against infringement of intellectual property rights.

In no event shall ETSI be held liable for loss of profits or any other incidental or consequential damages.

Any software contained in this deliverable is provided "AS IS" with no warranties, express or implied, including but not limited to, the warranties of merchantability, fitness for a particular purpose and non-infringement of intellectual property rights and ETSI shall not be held liable in any event for any damages whatsoever (including, without limitation, damages for loss of profits, business interruption, loss of information, or any other pecuniary loss) arising out of or related to the use of or inability to use the software.

---

**Copyright Notification**

No part may be reproduced or utilized in any form or by any means, electronic or mechanical, including photocopying and microfilm except as authorized by written permission of ETSI.

The content of the PDF version shall not be modified without the written authorization of ETSI.

The copyright and the foregoing restriction extend to reproduction in all media.

© ETSI 2022.  
All rights reserved.

---

# Intellectual Property Rights

## Essential patents

IPRs essential or potentially essential to normative deliverables may have been declared to ETSI. The declarations pertaining to these essential IPRs, if any, are publicly available for **ETSI members and non-members**, and can be found in ETSI SR 000 314: "*Intellectual Property Rights (IPRs); Essential, or potentially Essential, IPRs notified to ETSI in respect of ETSI standards*", which is available from the ETSI Secretariat. Latest updates are available on the ETSI Web server (<https://ipr.etsi.org/>).

Pursuant to the ETSI Directives including the ETSI IPR Policy, no investigation regarding the essentiality of IPRs, including IPR searches, has been carried out by ETSI. No guarantee can be given as to the existence of other IPRs not referenced in ETSI SR 000 314 (or the updates on the ETSI Web server) which are, or may be, or may become, essential to the present document.

## Trademarks

The present document may include trademarks and/or tradenames which are asserted and/or registered by their owners. ETSI claims no ownership of these except for any which are indicated as being the property of ETSI, and conveys no right to use or reproduce any trademark and/or tradename. Mention of those trademarks in the present document does not constitute an endorsement by ETSI of products, services or organizations associated with those trademarks.

**DECT™**, **PLUGTESTS™**, **UMTS™** and the ETSI logo are trademarks of ETSI registered for the benefit of its Members. **3GPP™** and **LTE™** are trademarks of ETSI registered for the benefit of its Members and of the 3GPP Organizational Partners. **oneM2M™** logo is a trademark of ETSI registered for the benefit of its Members and of the oneM2M Partners. **GSM®** and the GSM logo are trademarks registered and owned by the GSM Association.

---

# Legal Notice

This Technical Report (TR) has been produced by ETSI 3rd Generation Partnership Project (3GPP).

The present document may refer to technical specifications or reports using their 3GPP identities. These shall be interpreted as being references to the corresponding ETSI deliverables.

The cross reference between 3GPP and ETSI identities can be found under <http://webapp.etsi.org/key/queryform.asp>.

---

# Modal verbs terminology

In the present document "**should**", "**should not**", "**may**", "**need not**", "**will**", "**will not**", "**can**" and "**cannot**" are to be interpreted as described in clause 3.2 of the [ETSI Drafting Rules](#) (Verbal forms for the expression of provisions).

"**must**" and "**must not**" are **NOT** allowed in ETSI deliverables except when used in direct citation.

# Contents

Intellectual Property Rights .....	2
Legal Notice .....	2
Modal verbs terminology.....	2
Foreword.....	5
Introduction .....	6
1 Scope .....	7
2 References .....	7
3 Definitions of terms, symbols and abbreviations .....	8
3.1 Terms.....	8
3.2 Symbols.....	8
3.3 Abbreviations .....	8
4 Services and requirements.....	9
5 LTE V2X.....	10
5.1 V2X sidelink physical layer .....	10
5.1.1 Physical sidelink channels and signals.....	10
5.1.2 Sidelink synchronization.....	11
5.1.2.1 Synchronization references and priorities .....	11
5.1.2.2 SLSS .....	11
5.1.2.2.1 SLSSID.....	12
5.1.3 Concurrent operation and carrier aggregation.....	12
5.2 V2X sidelink resource allocation .....	13
5.2.1 Resource pools.....	13
5.2.2 Resource allocation modes .....	14
5.2.2.1 Resource allocation mode 3 .....	14
5.2.2.2 Resource allocation mode 4 .....	15
5.2.2.2.1 Zones .....	16
5.2.2.3 Modes 3 and 4 resource pool sharing.....	17
5.3 Sidelink congestion control .....	17
5.4 V2X sidelink higher-layer protocols .....	17
5.4.1 General.....	17
5.4.2 Resource pool configuration.....	18
5.4.3 Measurement and reporting .....	18
5.4.4 Mobility management.....	18
5.4.5 Assistance information for SL SPS configuration .....	18
5.4.6 Transmission carrier selection .....	18
5.4.7 SL packet duplication .....	18
5.4.8 Coordination between UL and V2X SL transmission.....	19
5.4.9 Multi-PLMN operation.....	19
5.5 V2X via the Uu interface.....	19
5.6 Network aspects .....	19
5.6.1 V2X service authorization .....	19
5.6.2 Sidelink AMBR .....	19
6 NR V2X.....	20
6.1 Sidelink unicast, groupcast, and broadcast.....	20
6.2 V2X sidelink physical layer .....	20
6.2.1 Physical sidelink channels and signals.....	20
6.2.2 Sidelink synchronization.....	22
6.2.2.1 Synchronization references and priorities .....	22
6.2.2.2 S-SSB and SLSS .....	22
6.2.2.2.1 SLSSID.....	23
6.2.3 Sidelink CSI.....	23
6.2.4 Sidelink HARQ.....	23

6.2.5	In-device coexistence between LTE-V2X and NR-V2X sidelinks.....	23
6.2.6	Concurrent operation .....	24
6.3	V2X sidelink resource allocation .....	24
6.3.1	Sidelink bandwidth parts and resource pools.....	24
6.3.1.1	Sidelink bandwidth parts .....	24
6.3.1.2	Resource pools .....	24
6.3.2	Resource allocation modes.....	25
6.3.2.1	Mode 1 .....	25
6.3.2.2	Mode 2 .....	25
6.4	Sidelink congestion control .....	28
6.5	V2X sidelink higher-layer protocols .....	28
6.5.1	General.....	28
6.5.2	Measurement and reporting related to NR sidelink communication.....	29
6.5.3	Mobility management for NR SL transmission/reception .....	30
6.5.4	Assistance information and SL configured grant configuration .....	30
6.5.5	Coordination between UL and NR SL transmission.....	30
6.5.6	QoS mechanism .....	30
6.5.7	Sidelink RRC.....	30
6.6	V2X via the Uu interface.....	31
6.7	Network aspects .....	31
6.7.1	V2X service authorization .....	31
6.7.2	Alternative QoS Profiles .....	31
6.8	Inter-UE coordination.....	31
7	Multi-RAT V2X.....	32
7.1	Cross-RAT operation .....	32
7.2	MR-DC.....	32
8	Transmission profiles .....	34
9	Battery-limited UEs.....	35
9.1	Power supply .....	35
9.2	Partial sensing .....	35
9.3	Sidelink DRX .....	36
10	Roadside unit.....	36
<b>Annex &lt;A&gt; (informative): Change history .....</b>		<b>38</b>
History .....		39

---

# Foreword

This Technical Report has been produced by the 3rd Generation Partnership Project (3GPP).

The contents of the present document are subject to continuing work within the TSG and may change following formal TSG approval. Should the TSG modify the contents of the present document, it will be re-released by the TSG with an identifying change of release date and an increase in version number as follows:

Version x.y.z

where:

- x the first digit:
  - 1 presented to TSG for information;
  - 2 presented to TSG for approval;
  - 3 or greater indicates TSG approved document under change control.
- y the second digit is incremented for all changes of substance, i.e. technical enhancements, corrections, updates, etc.
- z the third digit is incremented when editorial only changes have been incorporated in the document.

In the present document, certain modal verbs have the following meanings:

- shall** indicates a mandatory requirement to do something
- shall not** indicates an interdiction (prohibition) to do something

NOTE 1: The constructions "shall" and "shall not" are confined to the context of normative provisions, and do not appear in Technical Reports.

NOTE 2: The constructions "must" and "must not" are not used as substitutes for "shall" and "shall not". Their use is avoided insofar as possible, and they are not used in a normative context except in a direct citation from an external, referenced, non-3GPP document, or so as to maintain continuity of style when extending or modifying the provisions of such a referenced document.

- should** indicates a recommendation to do something
- should not** indicates a recommendation not to do something
- may** indicates permission to do something
- need not** indicates permission not to do something

NOTE 3: The construction "may not" is ambiguous and is not used in normative elements. The unambiguous constructions "might not" or "shall not" are used instead, depending upon the meaning intended.

- can** indicates that something is possible
- cannot** indicates that something is impossible

NOTE 4: The constructions "can" and "cannot" shall not to be used as substitutes for "may" and "need not".

- will** indicates that something is certain or expected to happen as a result of action taken by an agency the behaviour of which is outside the scope of the present document
- will not** indicates that something is certain or expected not to happen as a result of action taken by an agency the behaviour of which is outside the scope of the present document
- might** indicates a likelihood that something will happen as a result of action taken by some agency the behaviour of which is outside the scope of the present document

**might not** indicates a likelihood that something will not happen as a result of action taken by some agency the behaviour of which is outside the scope of the present document

In addition:

**is** (or any other verb in the indicative mood) indicates a statement of fact

**is not** (or any other negative verb in the indicative mood) indicates a statement of fact

NOTE 5: The constructions "is" and "is not" do not indicate requirements.

---

## Introduction

The 3GPP platform was first expanded to the automotive industry by the introduction of support for V2V and V2X services in Release 14. This support forms Phase 1 of 3GPP's ongoing project relating to V2X, and was intended to support a set of requirements sufficient for basic road safety services. Vehicles containing UEs with these features can use the uplink, downlink and sidelink to exchange information on their own status, such as position, speed, and heading with other nearby vehicles, infrastructure nodes, and pedestrians. Phase 2 of the V2X project was standardised in Release 15, and adds a number of new features to the sidelink intended to enhance efficiency and exploit developments in UE and network designs. These enhancements include sidelink carrier aggregation, higher-order modulation, and reduced latency.

Phase 3 of V2X, in Release 16, adds support to NR (and also 5GC, not addressed in this TR) for advanced V2X use cases, and includes introduction of the NR sidelink. The use-cases are broadly grouped to enable vehicular platooning, exchange of extended sensor information, advanced driving, and remote driving. Phase 3 also allows either RAT's sidelink to be operated under control of the other RAT's Uu interface, as well as permitting connection to EPC or 5GC, to enable usage in the main MR-DC deployment scenarios.

In the following clauses, LTE-V2X is described first, then NR-V2X, and finally certain aspects which have a degree of commonality to both RATs.

Although this TR deals with RAN aspects, note that the core network architectures also have many adaptations to support V2X in both EPC and 5GC. These are referred to only as needed for other explanations in this TR, and details can be found in the relevant specifications.

---

# 1 Scope

The present document provides an overall description of the features introduced by 3GPP to LTE and NR in support of V2X services, starting from Rel-14. The purpose of this TR is to give an overview across the RAN specifications of how the features have been designed, and how they operate together. This document addresses LTE V2X and NR V2X via both sidelink, i.e. the PC5 interfaces, and via the cellular uplink/downlink, i.e. the Uu interfaces. It covers V2V, V2I/N, and V2P, as well as the eNB/gNB, UE, and RSU nodes. The intention is to provide descriptions at approximately the Stage 2 level of detail, and thus references are provided to RAN specifications for the reader to obtain precise details.

The document is a 'living' document, i.e. it is permanently updated and presented to TSG-RAN meetings.

---

# 2 References

The following documents contain provisions which, through reference in this text, constitute provisions of the present document.

- References are either specific (identified by date of publication, edition number, version number, etc.) or non-specific.
- For a specific reference, subsequent revisions do not apply.
- For a non-specific reference, the latest version applies. In the case of a reference to a 3GPP document (including a GSM document), a non-specific reference implicitly refers to the latest version of that document *in the same Release as the present document*.

- [1] 3GPP TR 21.905: "Vocabulary for 3GPP Specifications".
- [2] 3GPP TR 36.885: "Study on LTE-based V2X Services".
- [3] ETSI EN 302 637-2: "Specification of Cooperative Awareness Basic Service".
- [4] SAE J2735: "Dedicated Short Range Communications (DSRC) Message Set Dictionary".
- [5] ETSI EN 302 637-3 "Specifications of Decentralized Environmental Notification Basic Service".
- [6] 3GPP TS 22.185: "Service requirements for V2X services".
- [7] 3GPP TS 22.186: "Enhancement of 3GPP support for V2X scenarios".
- [8] 3GPP TS 36.211: "Evolved Universal Terrestrial Radio Access (E-UTRA); Physical channels and modulation".
- [9] 3GPP TS 36.212: "Evolved Universal Terrestrial Radio Access (E-UTRA); Multiplexing and channel coding".
- [10] 3GPP TS 36.331: "Evolved Universal Terrestrial Radio Access (E-UTRA); Radio Resource Control (RRC)".
- [11] 3GPP TS 36.101: "Evolved Universal Terrestrial Radio Access (E-UTRA); User Equipment (UE) radio transmission and reception".
- [12] 3GPP TS 36.214: "Evolved Universal Terrestrial Radio Access (E-UTRA); Measurements".
- [13] 3GPP TS 36.300: "Evolved Universal Terrestrial Radio Access (E-UTRA) and Evolved Universal Terrestrial Radio Access Network (E-UTRAN); Overall description; Stage 2".
- [14] 3GPP TS 36.321: "Evolved Universal Terrestrial Radio Access (E-UTRA); Medium Access Control (MAC)".
- [15] 3GPP TS 36.323: "Evolved Universal Terrestrial Radio Access (E-UTRA); Packet Data Convergence Protocol (PDCP)".



- [16] 3GPP TS 38.211: "NR; Physical channels and modulation".
- [17] 3GPP TS 38.331: "NR; Radio Resource Control (RRC) protocol specification".
- [18] 3GPP TS 38.213: "NR; Physical layer procedures for control".
- [19] 3GPP TS 37.340: "Evolved Universal Terrestrial Radio Access (E-UTRA) and NR; Multi-connectivity; Stage 2".
- [20] 3GPP TS 38.300: "NR; NR and NG-RAN Overall Description; Stage 2".
- [21] 3GPP TS 38.321: "NR; Medium Access Control (MAC) protocol specification".
- [22] 3GPP TS 38.101-1: "NR; User Equipment (UE) radio transmission and reception; Part 1: Range 1 Standalone".

---

## 3 Definitions of terms, symbols and abbreviations

### 3.1 Terms

For the purposes of the present document, the terms given in TR 21.905 [1] and the following apply. A term defined in the present document takes precedence over the definition of the same term, if any, in TR 21.905 [1].

**example:** text used to clarify abstract rules by applying them literally.

### 3.2 Symbols

For the purposes of the present document, the following symbols apply:

<symbol>      <Explanation>

### 3.3 Abbreviations

For the purposes of the present document, the abbreviations given in TR 21.905 [1] and the following apply. An abbreviation defined in the present document takes precedence over the definition of the same abbreviation, if any, in TR 21.905 [1].

Where the same abbreviation is used for LTE V2X and NR V2X, which is meant can be derived from the clause within which it appears, unless otherwise stated.

5GC	Fifth Generation core network
AGC	Automatic gain control
AMBR	Aggregate maximum bit rate
BSM	Basic safety message
BWP	Bandwidth part
CA	Carrier aggregation
CAM	Cooperative awareness message
CBR	Channel busy ratio
CPS	Contiguous partial sensing
CR	Channel occupancy ratio
DENM	Decentralized environmental notification message
DMRS	Demodulation reference signal
DRX	Discontinuous reception
EPC	Evolved packet core
MBSFN	Multicast-broadcast single-frequency network
MNO	Mobile network operator
PBPS	Periodic-based partial sensing
PPPP	ProSe per-packet priority
PPPR	ProSe per-packet reliability

PSBCH	Physical sidelink broadcast channel
PSCCH	Physical sidelink control channel
PSSCH	Physical sidelink shared channel
PSSS, S-PSS	Primary sidelink synchronization signal (LTE), sidelink primary synchronization signal (NR)
PT-RS	Phase-tracking reference signal
P-UE	Pedestrian UE
RSU	Roadside unit
SA	Scheduling assignment
SCI	Sidelink control information
SC-PTM	Single-cell point-to-multipoint
SL-BCH	Sidelink broadcast channel
SLSS	Sidelink synchronization signal
S-RSSI	Sidelink received signal strength indicator
S-SSB	Sidelink synchronization signal block
SSSS, S-SSS	Secondary sidelink synchronization signal (LTE), sidelink secondary synchronization signal (NR)
V2I	Vehicle-to-infrastructure
V2P	Vehicle-to-pedestrian
V2V	Vehicle-to-vehicle
V2X	Vehicle-to-everything

---

## 4 Services and requirements

LTE-V2X is designed with BSM, CAM, and DENM particularly in mind. BSMs and CAMs have the characteristic of generating periodic messages at intervals, whereas DENMs are event-triggered. As an illustration of the different message types, in TR 36.885 [2], BSM/CAM were modelled, for evaluation purposes, as periodically occurring sets of one 300-byte message followed by four 190-byte messages. These types of message regularly broadcast information such as the vehicle's heading, speed, latitude/longitude, etc. ETSI EN 302 637-2 [3], SAE J2735 [4]. In TR 36.885 [2], DENMs were modelled, for evaluation purposes, as Poisson distributed initiations of six 800-byte messages spaced by 100 ms. DENMs can contain various different messages depending on the cause for their transmission, such as imminent collision, sudden braking, or detection of a traffic jam, amongst others ETSI EN 302 637-3 [5]. The requirements relating to traffic size and pattern for LTE-V2X set in TS 22.185 [6] can be summarized as follows, although they do not limit the usage of LTE-V2X. Other requirements relating to general system function are also included in TS 22.185 [6].

- Support for periodic broadcast messages with payloads of 50-300 bytes.
- Support for event-triggered messages with payloads of up to 1200 bytes.
- Up to 10 messages per second transmitted by a UE.
- V2V and V2P latency of maximum 100 ms, or for V2V pre-crash sensing, maximum 20 ms.
- V2I latency, i.e. between a UE and RSU, of maximum 100 ms.
- V2N latency, i.e. when transferring messages via the cellular network, of maximum 1000 ms.
- Maximum relative velocity between two vehicles of 500 km/h, and maximum absolute velocity of 250 km/h for V2V and V2P UEs, and of a UE communicating with an RSU.
- Requirements relating to security, integrity, authorization, and privacy.

NR V2X is designed with a broader set of more advanced V2X use cases in mind. These were specified in TS 22.18 [7], and are broadly arranged into four use case groups: vehicular platooning, extended sensors, advanced driving, and remote driving.

- 1) Vehicles Platooning enables the vehicles to dynamically form a platoon travelling together. All the vehicles in the platoon obtain information from the leading vehicle to manage this platoon. These information allow the vehicles to drive closer than normal in a coordinated manner, going to the same direction and travelling together.
- 2) Extended Sensors enables the exchange of raw or processed data gathered through local sensors or live video images among vehicles, road site units, devices of pedestrian and V2X application servers. The vehicles can

increase the perception of their environment beyond of what their own sensors can detect and have a more broad and holistic view of the local situation. High data rate is one of the key characteristics.

- 3) Advanced Driving enables semi-automated or full-automated driving. Each vehicle and/or RSU shares its own perception data obtained from its local sensors with vehicles in proximity and that allows vehicles to synchronize and coordinate their trajectories or manoeuvres. Each vehicle shares its driving intention with vehicles in proximity too.
- 4) Remote Driving enables a remote driver or a V2X application to operate a remote vehicle for those passengers who cannot drive by themselves or remote vehicles located in dangerous environments. For a case where variation is limited and routes are predictable, such as public transportation, driving based on cloud computing can be used. High reliability and low latency are the main requirements.

The most demanding requirements set in TS 22.186 [7] are for a maximum sidelink range of 1000 m, a maximum throughput of 1 Gbps, a shortest latency of 3 ms, a maximum reliability of 99.999%, and a maximum transmission rate of 100 messages/second. However, there is not a use case which, on its own, demands all of these bounding requirements. The communication scenarios described in TS 22.186 [7] include a mixture of periodic and aperiodic services. Similar to LTE-V2X, there are also requirements relating to security, integrity, authorization, and privacy.

## 5 LTE V2X

### 5.1 V2X sidelink physical layer

The LTE V2X sidelink supports broadcast transmission of messages in the physical layer, since this is a suitable approach for delivery BSM, CAM, DENM and similar traffic. In the MAC layer, a broadcast address can be mapped to a single UE or a group of UEs by implementation. Such implementation techniques have no particular specification support in LTE, and are transparent to the physical layer.

#### 5.1.1 Physical sidelink channels and signals

The LTE V2X sidelink uses the following physical channels and signals:

- Physical sidelink broadcast channel (PSBCH), specified in TS 36.211 [8, clause 9.6]
- Physical sidelink control channel (PSCCH), specified in TS 36.211 [8, clause 9.4]
- Physical sidelink shared channel (PSSCH), specified in TS 36.211 [8, clause 9.3]
- Primary and secondary sidelink synchronization signals (PSSS and SSSS) specified in TS 36.211 [8, clause 9.7]. These can be referred to jointly as the sidelink synchronization signal (SLSS).
- A demodulation reference signal (DMRS) associated with each of the three physical channels, specified in TS 36.211 [8, clause 9.8]

LTE-V2X sidelink physical channels are transmitted using SC-FDMA.

PSBCH transmits the SL-BCH transport channel, which carries the sidelink V2X Master Information Block (MIB-V2X) from the RRC layer. When in use, PSBCH transmits MIB-V2X every 160 ms in the central 72 subcarriers of the SL bandwidth. DMRS associated with PSBCH are transmitted in the 5th, 7th, and 10th symbols of the subframe.

PSSS and SSSS are transmitted to allow other UEs to achieve sidelink synchronization when they do not have another source of synchronization available. They jointly convey the SLSS ID selected by the UE. For further details of SLSS and synchronization, refer to Clause 5.1.2. PSSS/SSSS also allow UEs to detect the sidelink subframe boundary, with subframe number and frame number signalled in MIB-V2X.

PSSCH transmits the SL-SCH transport channel, which carries the TBs of data for transmission over SL. The resources in which PSSCH is transmitted can either be scheduled by an eNB and granted to the UE by a DCI (termed resource allocation mode 3, see Clause 5.2.2.1) or determined through a sensing procedure conducted autonomously by the transmitting UE (termed resource allocation mode 4, see Clause 5.2.2.2). A given TB can be transmitted once or twice, with a second transmission occurring a time gap after the first which is indicated in the scheduling SCI.

PSCCH transmits physical layer sidelink control information (SCI), also known as a scheduling assignment (SA). For V2X, PSCCH is transmitted in two frequency-adjacent PRBs, and always carries SCI format 1, defined in TS 36.212 [9, clause 5.4.3.1.2]. To receive PSCCH, a UE has to monitor each defined pair of PRBs to determine whether PSCCH has been transmitted in them. PSCCH is transmitted in the same subframe(s) as the associated PSSCH, and can be transmitted in PRBs that are either frequency adjacent or frequency non-adjacent to the PSSCH.

DMRS associated with PSSCH and PSCCH are transmitted in the 3rd, 6th, 9th, and 12th symbols of a subframe.

## 5.1.2 Sidelink synchronization

### 5.1.2.1 Synchronization references and priorities

There are four basic sources, or references, from which a V2X UE can derive its own synchronization: GNSS, its serving eNB, another UE transmitting SLSS (a SyncRef UE), or its own internal clock. In general, GNSS or eNB are regarded as the highest-quality sources. SyncRef UEs are distinguished between those which are directly synchronized to GNSS or an eNB, those which are 1 further step away, and those which are  $\geq 2$  further steps away from GNSS/eNB. As a last resort, a UE unable to find any other synchronization reference will use its own internal clock to transmit SLSS. The V2X synchronization procedure defines a hierarchy or set of priorities among such synchronization references and requires all UEs to continuously search the hierarchy to get to the highest-quality one they can find. The general preference order is as follows, with details specified in TS 36.331 [10, clause 5.10.8]:

- Level 1. Either GNSS or eNB, according to (pre-)configuration.
- Level 2. A SyncRef UE directly synchronized to a Level 1 source.
- Level 3. A SyncRef UE synchronized to a Level 2 source, i.e. indirectly synchronized to a Level 1 source.
  - When the Level 1 preference is (pre-)configured as GNSS, in Level 2 and 3, SyncRef UEs in hierarchies derived from GNSS and eNB are of equal preference as a synchronization source.
- Level 4. Any other SyncRef UE.
- Level 5. UE's internal clock.

Within a Level 2, or 3, or 4 set of SyncRef UEs, the one with the highest S-RSRP is selected. The hierarchy also allows fallback between eNB-derived and GNSS-derived chains should the Level 1 type chosen by (pre-)configuration be unsuitable.

### 5.1.2.2 SLSS

The transmission and reception of SLSS (and PSBCH) is an optional V2X UE capability, and they can be transmitted on one or multiple synchronization carriers.

A UE which is deriving its own synchronization from eNB or GNSS can be configured by the network to transmit SLSS on a synchronization carrier, or the network can permit it to do so if the RSRP of a reference cell falls below a threshold. If the network is not available, and the UE is synchronized to GNSS, it will transmit SLSS if permitted by its pre-configuration. When such a UE does not have GNSS synchronization, it will transmit SLSS, if permitted by its pre-configuration, while it cannot find a SyncRef UE with sufficiently high S-RSRP. Full details of the conditions for SLSS transmission are specified in TS 36.331 [10, clause 5.10.7.2].

In a V2X system, there can be a variety of UEs which are deriving synchronization from different sources, and since a UE can transmit SLSS on multiple carriers, it can have different synchronization sources among them. SLSS is therefore transmitted in different subframes depending on what synchronization source the UE is using. The system can be configured with either two or three different offsets with respect to the start of the 160 ms PSBCH period can be defined, which can allow different subframes for transmission according to whether the UE is synchronized to GNSS, eNB, or another SyncRef UE.

PSSS and SSSS use the same sequences as PSS and SSS, respectively, with different root indices. When in use, both sequences are transmitted in the central 62 subcarriers of the SL bandwidth, in the same subframe as PSBCH, i.e. every 160 ms. PSSS is in the 2nd and 3rd symbols of the subframe, and SSSS in the 12th and 13th symbols. The two symbols of each signal are the same, which allows detectors to benefit from phase tracking between the two symbols. Figure 5.1.2.1-1 shows the relevant contents of a subframe which contain PSBCH, PSSS, and SSSS.

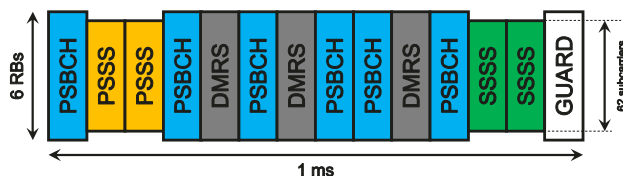

Figure 5.1.2.2-1: Contents of an LTE-V2X synchronization subframe.

#### 5.1.2.2.1 SLSSID

The SLSSID itself conveys information about the synchronization source of the transmitting UE. In general, the further a UE is away from a high-quality source of GNSS or eNB, the lower quality will be its own synchronization and thus the quality of an SLSS it transmits. There are a series of association rules among SLSS IDs, designed to allow the identification, and propagation through the system of, high-quality synchronization sources. Thus, for example, a UE which is in-coverage and directly synchronized to an eNB (a Level 2 SyncRef UE) uses an SLSSID which is configured by the network from 1-167, allowing SLSSID planning, and a UE using such a UE as a SyncRef UE (a Level 3 SyncRef UE) uses the same SLSSID, but indicates in V2X MIB that it is not directly eNB-synchronized. Subsequent UEs in this example hierarchy (Level 4 SyncRef UEs) use the SLSSID+168 to indicate their source is not directly synchronized to an eNB. A similar propagation hierarchy is used starting with a UE which is directly synchronized to GNSS, whose SLSSID is always 0, resulting in any UE which is more than one further step from GNSS using SLSSID 168 (or, in some cases, 169) so that a synchronization hierarchy based on GNSS can always be identified. Finally, a UE which cannot find GNSS, eNB, nor a SyncRef UE, selects an SLSSID randomly from 170-335, and UEs which synchronize to it propagate the same SLSSID.

### 5.1.3 Concurrent operation and carrier aggregation

V2X operation is defined in band 47 in TS 36.101 [11, clause 5.5G], which supports single-carrier and multi-carrier operation:

Table 5.1.3-1: V2X operating band

E-UTRA Operating Band	E-UTRA V2X Operating Band	V2X UE transmit		V2X UE receive		Duplex Mode	Interface
		$F_{UL\_low}$	$F_{UL\_high}$	$F_{DL\_low}$	$F_{DL\_high}$		
47	47	5855 MHz	5925 MHz	5855 MHz	5925 MHz	HD	PC5

The V2X sidelink in band 47 can be operated concurrently with Uu FDD bands 3, 5, 7, 8, 20, 28, 71; Uu TDD bands 34, 39, 41; and NR Uu bands n1, n8, n39, n40, n71, n78, n79.

Sidelink CA is defined for resource allocation modes 3 and 4. When operating in CA, a given (sidelink) MAC PDU is transmitted, and if necessary re-transmitted, on a single sidelink carrier, and multiple MAC PDUs can be transmitted in parallel on different carriers. This provides a throughput gain in a similar way as for Uu CA.

Sidelink CA in resource allocation mode 3 using a dynamic grant is similar to on the Uu interface, by including a carrier indication field (CIF) in the DCI from the eNB. This indicates which among the up to 8 configured sidelink carriers the allocation in the DCI applies to.

Sidelink CA in resource allocation mode 4 uses the sensing procedure described in Clause 5.2.2.2 to select resources independently on each involved carrier. The same carrier is used for all MAC PDUs of the same sidelink process at least until the process triggers resource re-selection. Procedures to avoid unexpected UE behaviour when the demands of CA become high are also specified, which allow a UE to drop a transmission which uses an unmanageable amount of resources or transmit chains, or to reject and re-select resources for which it cannot meet the RF requirements under CA.

Sidelink synchronization can also operate on multiple carriers, as mentioned in Clause 5.1.2. In addition, in sidelink CA operation, a SyncRef UE uses a single synchronization reference for all aggregated carriers, and may transmit SLSS/PSBCH on one or multiple of them according to capability. A receiving UE likewise uses the same

synchronization reference (not necessarily a SyncRef UE) for all its aggregated carriers, and it uses the highest priority synchronization reference present among the available synchronization carriers.

Another form of CA is PDCP duplication, where the same PDCP packet is transmitted in parallel on multiple sidelink carriers, to increase reliability. See Clause 5.4.7 for more discussion.

## 5.2 V2X sidelink resource allocation

### 5.2.1 Resource pools

PSCCH and PSSCH resources are defined within resource pools for the respective channels. This concept is used because in general PSCCH/PSSCH cannot be transmitted (and thus are not expected to be received) in all PRBs and subframes in the system bandwidth, nor within a given frequency span configured for V2X sidelink. The notion of a resource pool also reflects, in resource allocation mode 4, that a UE will make its resource selections based on sensing within the (PSSCH) pool.

For PSSCH, a resource pool is divided into sub-channels in the frequency domain, which are consecutively non-overlapping sets of  $\geq 4$  PRBs in a subframe, the size depending on (pre-)configuration. Resource allocation, sensing, and resource selection are performed in units of a sub-channel, although it is possible that a small number of PRBs within a sub-channel are not used for transmission.

For PSCCH, the resource pool definition depends on whether adjacent or non-adjacent transmission of PSCCH and PSSCH has been (pre-)configured for the resource pool. Adjacent transmission is achieved by defining the lowest pair of PRBs in each subchannel as candidates to contain PSCCH, and PSSCH is transmitted in the contiguous PRBs above them for the allocated number of subchannels. Non-adjacent transmission is achieved by defining sequential pairs of PRBs starting at the lowest frequency of the resource pool for PSCCH, and associating the  $n^{\text{th}}$  pair to PSSCH transmission occupying from the  $n^{\text{th}}$  PSSCH sub-channel for the allocated number of subchannels. Figure 5.2.1-1 shows examples of adjacent and non-adjacent transmission. To receive PSCCH, a UE has to monitor each defined pair of PRBs to determine whether PSCCH has been transmitted in them.

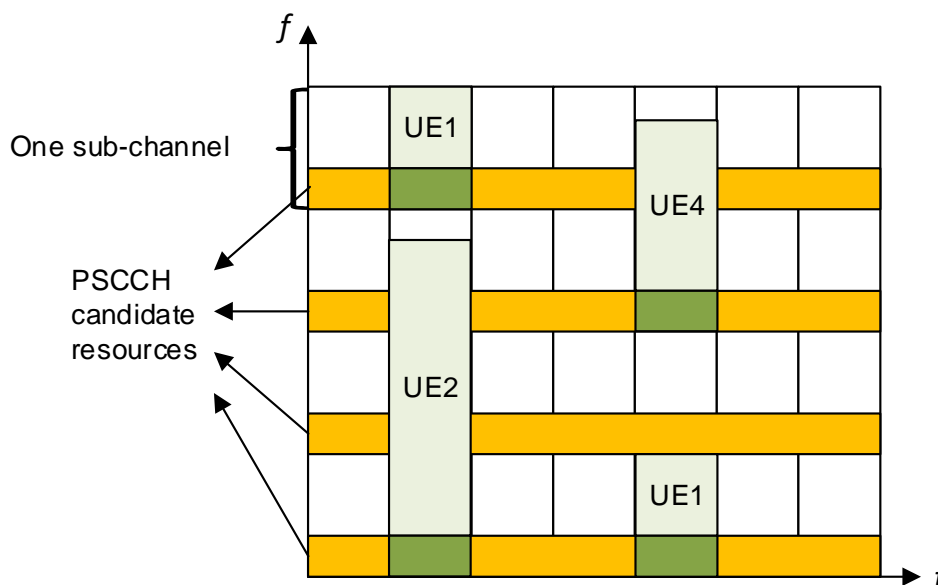
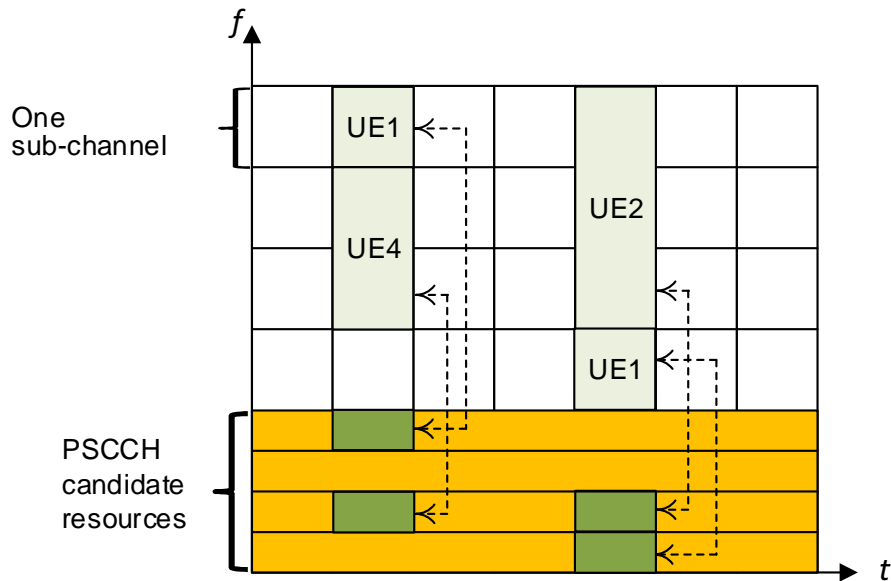

Figure 5.2.1-1a: Illustration of adjacent allocations of PSCCH and associated PSSCH.



**Figure 5.2.1-1b: Illustration of non-adjacent allocations of PSCCH and associated PSSCH.**

Resource pools are (pre-)configured to a UE separately from the transmission perspective (TX pools) and the reception perspective (RX pools). This allows a UE to monitor for PSCCH, and hence receive PSSCH transmissions, in resource pools other than those in which it transmits, so that it can attempt to receive transmissions made by other UEs in those RX pools.

In addition, there are exceptional resource pools configured to a UE, in its serving cell's SIB21 or in dedicated signalling. These can be used e.g. during RLF, handover, transition from RRC IDLE to RRC CONNECTED, or during change of dedicated V2X sidelink resource pools within a cell. In these cases, a UE may not have a stable configuration of TX resource pools but nevertheless should not be removed from the V2X system, so it can randomly select resources in the exceptional pool provided in its serving cell's SIB21 or in dedicated signalling, and use them temporarily. Likewise, UEs need to monitor the exceptional pools for PSCCH transmissions.

## 5.2.2 Resource allocation modes

LTE sidelink defines four resource allocation modes: 1, 2, 3, and 4. Modes 1 and 2 apply to D2D, while modes 3 and 4 apply to LTE V2X.

### 5.2.2.1 Resource allocation mode 3

Mode 3 is for resource allocation scheduled by eNB. As described in Clause 4, among the primary use cases for LTE-V2X is transmission of periodically-occurring messages, and for this reason there is particular support for sidelink SPS. However, dynamic sidelink grants are equally supported.

The eNB scheduling activity is driven by the UE needing to send data on sidelink performing a sidelink BSR procedure similar to that on Uu to request a sidelink resource allocation from eNB. Depending on the type of traffic the UE has, eNB can provide a dynamic sidelink grant, or an activation of a SPS sidelink grant.

A dynamic sidelink grant DCI provides, amongst other details TS 36.212 [9, clause 5.3.3.1.9A], the resources for up to two transmissions of the same TB. This is to allow higher reliability to be achieved without a feedback-based HARQ procedure, since LTE-V2X physical layer supports only broadcast transmission. Unlike Uu UL grants, the MCS information can optionally be provided by RRC signalling instead of the traditional DCI. For the case where RRC does not provide the MCS, the transmitting UE is left to select an appropriate MCS/TBS itself based on the knowledge it has of the TB to be transmitted and, potentially, the sidelink radio conditions. The transmitting UE populates its SCI with the information from eNB and other fields related to sidelink operation TS 36.212 [9, clause 5.4.3.1.2], and then transmits it and the associated PSSCH.

The UE can be configured by eNB with up to 8 sidelink SPS configurations. Each configuration has an identifying index, and provides a different periodicity of sidelink transmission resource. A sidelink SPS configuration is not used by the UE until the eNB sends the UE a DCI which indicates it is now active. The activating DCI also provides all the

same fields as a dynamic sidelink scheduling DCI described above, allowing the precise resource allocation for SPS to be determined by eNB at the time it is needed. A transmitting UE can use the thus activated sidelink SPS resources, at the configured periodicity, until they are released (i.e. de-activated) by the eNB transmitting a special DCI. Note that each time the UE uses the resources, it either uses the RRC configured MCS/TBS or selects one itself, i.e. the same way as dynamic operation.

#### 5.2.2.2 Resource allocation mode 4

Mode 4 is for UE autonomous resource selection. Its basic structure is of a UE sensing, within a (pre-)configured resource pool, which resources are not in use by other UEs with higher-priority traffic, and choosing an appropriate amount of such resources for its own PSCCH/PSSCH transmission. Having selected such resources, the UE can transmit in them on a periodic (i.e. SPS) basis for a certain number of times, or until a cause of resource reselection is triggered.

As described in Clause 5.2.2.1, the SCIs transmitted by UEs on PSCCH indicate the time-frequency resources in which the UE will transmit a PSSCH. The same SCI contents is used in mode 4, and also indicates the periodicity with which the UE will use the same resources. These SCI transmissions are used by sensing UEs to maintain a moving sensing window in the immediate past of which resources have been reserved by other UEs. This window is 1000 ms long for FDD systems. A sensing UE also measures the PSSCH-RSRP in the subframes of the sensing window, which implies the level of interference which would be caused and experienced if the sensing UE were to transmit in them.

The sensing UE then selects resources for its first transmission from within a resource selection window. This window begins  $\leq 4$  ms after the trigger for transmission, and is bounded by the latency requirement of the traffic, up to 100 ms (see Clause 4). The sensing UE assumes the same resources will be used by other UEs in the future as have been found reserved during the sensing window, according to the indicated periodicities and durations. Reserved resources in the selection window with PSSCH-RSRP above a threshold are excluded from being candidates by the sensing UE, with the threshold set according to the priorities (PPPP) of the traffic of the sensing and transmitting UE. Thus, a higher priority transmission from a sensing UE can occupy resources which are reserved by a transmitting UE with sufficiently low PSSCH-RSRP and sufficiently lower-priority traffic.

From the set of resources in the selection window which have not been excluded, the sensing UE identifies those containing the lowest total received energy as a way to account for transmissions which were not found during decoding of PSCCHs, and identifies resources totalling 20% of the available resources within the traffic's latency bound, including gradual relaxation of the PSSCH-RSRP exclusion thresholds in 3 dB steps if necessary. The UE then selects a resource at random from the identified 20% and uses this resource semi-persistently for its transmissions.

There are a number of triggers for resource re-selection. They are designed to support high mobility, and ensure that a UE cannot assume occupation of a resource for an excessive period, nor when the selected resource is either insufficient or excessive for what is needed by the UE's traffic, amongst other causes.



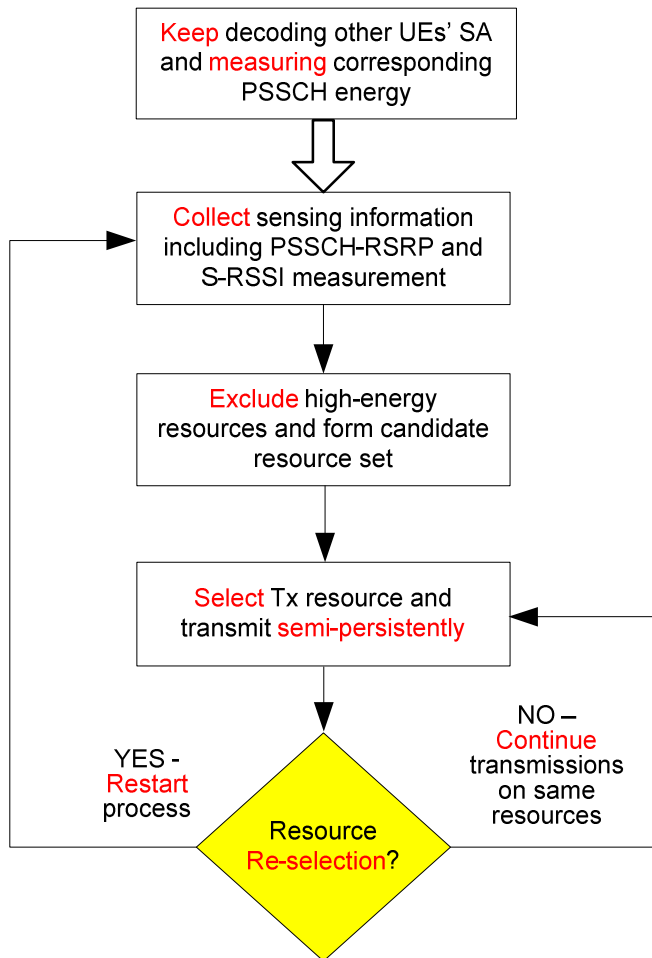

Figure 5.2.2.2-1: Summary of sensing and resource (re-)selection procedures.

5.2.2.2.1 Zones

Cellular networks are designed to support resource re-use over a given geographical area, to manage interference and improve area spectral efficiency. A similar concept is available in LTE-V2X. LTE-V2X can optionally divide the world into zones, which have a (pre-)configurable width and height. Nearby zones are assigned different resource pools, with spatially-periodic re-use over a distance controlled by the zone width and height. A UE performs transmission within the resource pool(s) associated with its current zone, for mode 4. Figure 5.2.3-1 shows an example of the configuration of zones, where those with the same zone\_id use the same transmission resource pools.

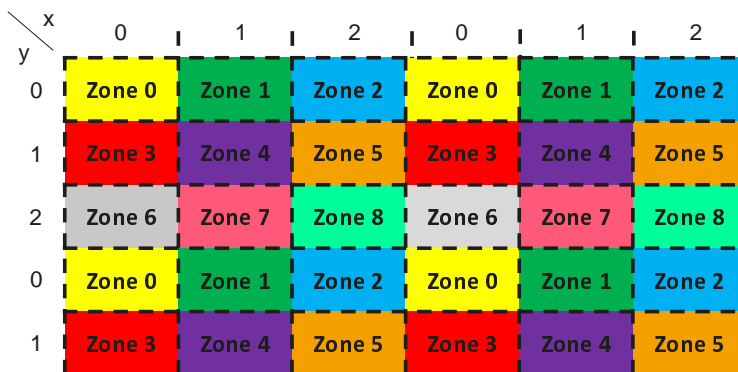

Figure 5.2.3-1: Illustration of zones.  $x' = \text{ceil}(x/L) \bmod N_x$ ;  $y' = \text{ceil}(y/W) \bmod N_y$ ;  $\text{zone\_id} = y' \times N_x + x'$ ; where  $x$  and  $y$  are the longitude and latitude of the UE's location,  $L$ ,  $W$  are the length and width of each zone, respectively, and  $N_x$ ,  $N_y$  are the number of zones in length and width respectively.

### 5.2.2.3 Modes 3 and 4 resource pool sharing

Resource pools for mode 3 and mode 4 are (pre-)configured separately from one another. In Rel-14, a receiving UE whether operating in mode 3 or mode 4 does not know in any particular way that a transmission in mode 3 has SPS characteristics, since the mode 3 SCI always indicates that its PSSCH transmission is single-shot. Thus, a mode 4 UE will not exclude the occupied resources during its resource selection procedure. In Rel-15, resource pool sharing is enabled by the mode 3 SCI also indicating a SPS reservation period, and mode 4 UEs of both releases are therefore able to account for such transmissions in the resource (re-)selection procedure.

It is also possible for a UE operating in mode 3 to perform the mode 4 sensing procedure in order to report to eNB regarding the occupancy of resources in the mode 4 pools. This provides information which the eNB can use in determining its scheduling behaviour for mode 3.

## 5.3 Sidelink congestion control

Each sidelink packet is associated with a PPPP and PPPR passed down ultimately to the physical layer from upper layers, which determine the values based on the QoS requirements of the message. PPPR allows management of reliability, for example see Clause 5.4.7. The PPPP of a packet is indicated dynamically in the SCI which schedules the PSSCH for the packet. A physical measurement of CBR is also defined in each subframe TS 36.214 [12, clause 5.1.30], which measures the portion of the resource in a resource pool which has a high received signal energy (S-RSSI) in the most recent 100 subframes. CBR is a measurement of the congestion present recently in the resource pool. Another measurement, CR defined in TS 36.214 [12, clause 5.1.31], counts the total number of subchannels a UE has and will transmit in during a window of up to 1000 ms including the current subframe. CR is thus a measurement of how much resource a UE has recently, and will soon, claim.

A UE can be (pre-)configured with a set of CBR ranges to each of which is linked a CR-limit. When a UE finds its CR exceeds the CR-limit for the CBR range it currently measures, it must reduce its CR to not exceed the limit. How this is done is up to UE implementation, and can include increasing MCS to reduce resource occupation, dropping (re-)transmissions, etc. PPPP can also be (pre-)configured with a mapping to the UE's maximum permitted transmit power, the limitation on which acts to reduce the CBR measured by sufficiently distant UEs.

PPPP is used as described in Clause 5.2.2 to aid distributed sidelink congestion control based on the relative priorities of traffic from UEs that consider occupying a given resource. PPPP and CBR can each also be (pre-)configured with mappings to ranges of values of transmission parameters, e.g. a range of MCS values, and/or a range of numbers of subchannels, etc. In this case, the UE has to choose its transmission parameters from within the range corresponding to the prevailing PPPP and/or CBR.

## 5.4 V2X sidelink higher-layer protocols

### 5.4.1 General

Figure 5.4.1-1 shows the user plane protocol stack for V2X sidelink communication. The Access Stratum protocol stack for user plane in the PC5 interface consists of PDCP, RLC, MAC and PHY as shown below in Figure 5.4.1-1. The detailed functions performed by PDCP, RLC and MAC sublayers are listed in TS 36.300 [13, clause 6], and some other details specific to V2X sidelink are described in TS 36.300 [13, clauses 23.10.2.1 and 23.14.1.1]. The PHY layer performs the functions described in Clause 5.1.

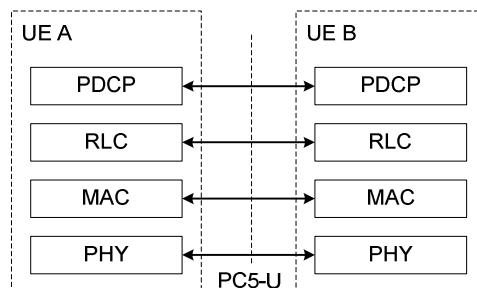
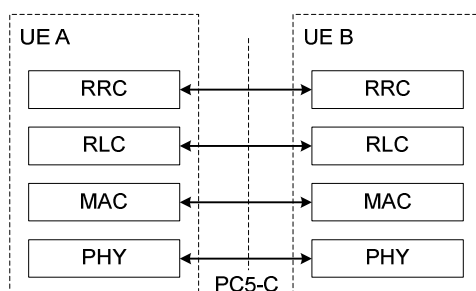

Figure 5.4.1-1: User-Plane protocol stack for V2X sidelink communication

Figure 5.4.1-2 shows the control plane protocol stack for V2X sidelink communication. The Access Stratum protocol stack for control plane in the PC5 interface consists of RRC, RLC, MAC and PHY as shown below in Figure 5.4.1-2. The control plane protocol for V2X sidelink communication is mainly used for the transmission of sidelink broadcast control channel (SBCCH), and its functions are detailed in TS 36.300 [13, clause 23.10.2.2].



**Figure 5.4.1-2: Control-Plane protocol stack for V2X sidelink communication**

## 5.4.2 Resource pool configuration

When the UE is in network coverage, it may use the resource configurations provided by the eNB via dedicated signalling or system information. When the UE is out of coverage, it may use pre-configured resource pools for V2X sidelink communication. Details of how the resource pools are (pre)configured and how the UE uses them for V2X sidelink communication transmission and reception are specified in TS 36.300 [17, clauses 5.10.12 and 5.10.13].

## 5.4.3 Measurement and reporting

Some measurement and reporting mechanisms are supported specifically for V2X sidelink communication, including CBR measurement and reporting, reporting of its sensing results and geo-location reporting. Details of above listed measurement and reporting mechanism specific for V2X sidelink communication are specified in TS 36.331 [10, clause 5.5].

## 5.4.4 Mobility management

UE can perform V2X sidelink transmission and reception during handover and cell reselection. Related details are specified in TS 36.331 [10, clause 5.10.13.1].

## 5.4.5 Assistance information for SL SPS configuration

The UE can report UE assistance information to the eNB to facilitate the configuration of sidelink SPS described in Clause 5.2.2.1. Details of the UE assistance information for sidelink SPS configuration are specified in TS 36.331 [10, clause 5.6.10].

## 5.4.6 Transmission carrier selection

For V2X sidelink communication, the UE is allowed to transmit and receive on multiple sidelink carriers (pre)configured by the network, and the UE selects specific sidelink carriers among them for transmission. The (pre)configured sidelink carriers can be provided by the network as specified in TS 36.331 [10, clause 5.10.13.1]. Details of transmission carrier selection are specified in TS 36.321 [14, clause 5.14.1.5].

## 5.4.7 SL packet duplication

To improve the reliability of V2X sidelink communication, a sidelink PDCP duplication mechanism is supported, where a PDCP PDU is duplicated into two instances and transmitted on two different sidelink carriers. Details of sidelink PDCP duplication are specified in TS 36.323 [15, clause 5.1.3 and 5.1.4] as well as TS 36.321 [14, clause 5.14.1.3.1].

## 5.4.8 Coordination between UL and V2X SL transmission

There is the possibility that the UE needs to perform UL transmission and V2X sidelink transmission overlapped in time domain, but the UE cannot transmit both. In this case, the UE will prioritize between the two transmissions. Details of the prioritization between UL transmission and V2X sidelink transmission are specified in TS 36.321 [14, clauses 5.4.2.2 and 5.14.1.2.2].

## 5.4.9 Multi-PLMN operation

To support multi-PLMN operation for V2X sidelink communication, the UE may receive the V2X sidelink communication of other PLMNs. However, V2X sidelink transmission in other PLMNs is not allowed. The same sidelink resource pool may be configured to the eNBs within a PLMN. Details of multi-PLMN operation for V2X sidelink communication are specified in TS 36.331 [10, clause 23.14.1.1].

## 5.5 V2X via the Uu interface

LTE-V2X, as mentioned above, is focused on transmission of a few types of periodic traffic, which can have different periodicities. Apart from using the sidelink, it is possible to transfer V2X data via the cellular network UL/DL, taking advantage of its centrally-scheduled operation, predictable latency bounds, and inter-cell communications.

An extended form of UL SPS for V2X is supported, to allow firstly that V2X UL SPS and normal UL SPS can be used together, and also that multiple V2X UL SPS configurations can be defined to account for the different periodic V2X traffic types. Whereas in Rel-8 UL SPS a single SPS configuration can be provided by RRC, for LTE-V2X, up to 8 UL SPS configurations can be provided, similar to on the sidelink, which the eNB is assisted in the configuration of by information on traffic characteristics, etc., reported provided by the UE. A specialised version of DCI format 0 is then used to activate/release UL V2X SPS configurations as needed, and separately from the normal UL SPS configuration.

LTE supports multicast/broadcast operation via SC-PTM and MBSFN transmission. These transmission types can also be used for V2X messages, and some adaptations for LTE-V2X are included to allow scheduling more frequent transmissions of data and service (re-)configuration information.

## 5.6 Network aspects

### 5.6.1 V2X service authorization

Considering the different UE types based on subscription information in the HSS, the eNB receives the authorization status of the UE provided by a MME or a neighbour eNB, to know whether the UE is authorized as a Vehicle UE and/or a Pedestrian UE.

Only authorized UEs can perform V2X sidelink communication. Sidelink radio resources are provided to UEs in different ways according to the different services supported.

### 5.6.2 Sidelink AMBR

UE sidelink AMBR is provided to the eNB by a MME or a neighbour eNB, and used for the UE's sidelink communication in mode 3. The sidelink AMBR is based on subscription information from the HSS and the operator's policy, which is used to cap the PC5 transmission from a particular UE.

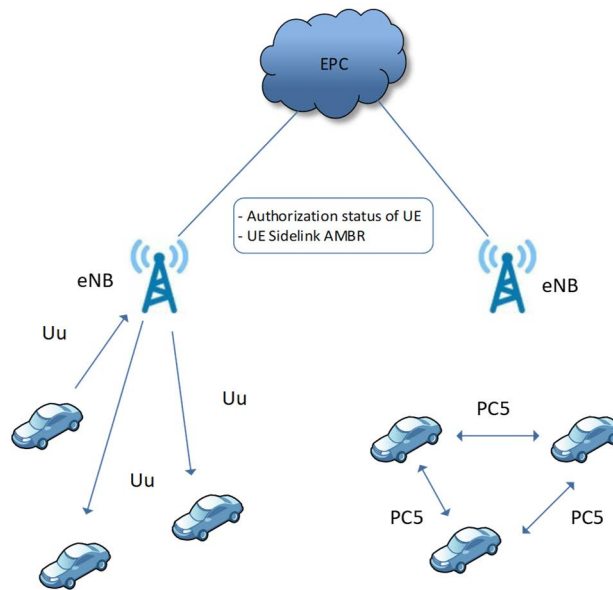

Figure 5.6-1 Network Infrastructure for LTE V2X.

## 6 NR V2X

### 6.1 Sidelink unicast, groupcast, and broadcast

Whereas LTE-V2X supports broadcast transmission in the physical layer and any finer-grained addressing is handled according to MAC layer ID implementation, NR V2X has physical layer support for broadcast, unicast, and groupcast sidelink operation. The addition of unicast and groupcast is linked with the introduction of sidelink HARQ feedback (clause 6.2.4), high order modulation, sidelink CSI, and PC5-RRC (clause 6.5.7), amongst other points.

### 6.2 V2X sidelink physical layer

#### 6.2.1 Physical sidelink channels and signals

The NR V2X sidelink uses the following physical channels and signals:

- Physical sidelink broadcast channel (PSBCH) and its DMRS, specified in TS 38.211 [16, clauses 8.3.3 and 8.4.1.4]
- Physical sidelink control channel (PSCCH) and its DMRS, specified in TS 38.211 [16, clauses 8.3.2 and 8.4.1.3]
- Physical sidelink shared channel (PSSCH) and its DMRS, specified in TS 38.211 [16, clauses 8.3.1 and 8.4.1.1]
- Physical sidelink feedback channel (PSFCH), specified in TS 38.211 [16, clause 8.3.4]
- Sidelink primary and secondary synchronization signals (S-PSS and S-SSS) specified in TS 38.211 [16, clause 8.4.2], which are organized into the sidelink synchronization signal block (S-SSB) together with PSBCH. S-PSS and S-SSS can be referred to jointly as the sidelink synchronization signal (SLSS).
- Phase-tracking reference signal (PT-RS) in FR2, specified in TS 38.211 [16, clause 8.4.1.2].
- Channel state information reference signal (CSI-RS), specified in TS 38.211 [16, clause 8.4.1.5]. See clause 6.2.3 for CSI.

NR-V2X sidelink supports subcarrier spacings of 15, 30, 60 and 120 kHz. Their associations to CPs and frequency ranges are as for NR UL/DL, but using only the CP-OFDM waveform. The modulation schemes available are QPSK, 16-QAM, 64-QAM, and 256-QAM.

PSBCH transmits the SL-BCH transport channel, which carries the sidelink V2X Master Information Block (MIB-V2X) from the RRC layer. When in use, PSBCH transmits MIB-V2X every 160 ms in 11 RBs of the SL bandwidth, with possible repetitions in the period. DMRS associated with PSBCH are transmitted in every symbol of the S-SSB slot. S-PSS and S-SSS are transmitted together with PSBCH in the S-SSB. They jointly convey the SLSS ID used by the UE. For further details of S-SSB, SLSS, and synchronization, refer to Clause 6.2.2.

Sidelink control information (SCI) in NR V2X is transmitted in two stages. The first-stage SCI is carried on PSCCH and contains information to enable sensing operations, information about the resource allocation of the PSSCH, and, when needed, indication that the UE can receive conflict information in inter-UE coordination.

PSSCH transmits the second-stage SCI and the SL-SCH transport channel. The second-stage SCI can carry information needed to identify and decode the associated SL-SCH, as well as control for HARQ procedures, triggers for CSI feedback, inter-UE coordination requests and information, etc. SL-SCH carries the TB of data for transmission over SL.

The resources in which PSSCH is transmitted can be scheduled or configured by a gNB (termed resource allocation mode 1, see Clause 6.3.2.1) or determined through a sensing procedure conducted autonomously by the transmitting UE (termed resource allocation mode 2, see Clause 6.3.2.2). A given TB can be transmitted multiple times, as described in Clauses 6.2.4 and 6.3.2. DMRS associated with rank-1 or rank-2 PSSCH can be transmitted in 2, 3, or 4 sidelink symbols distributed through a sidelink slot.

Multiplexing between PSCCH and PSSCH is in time and frequency within a slot, illustrated in two examples in Figure 6.2.1-1.

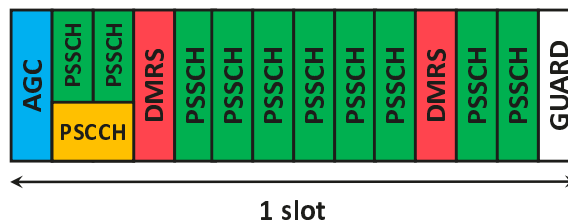

Figure 6.2.1-1(a): Example slot format of 2-symbol PSCCH, 2-symbol PSSCH-DMRS, and no PSFCH.

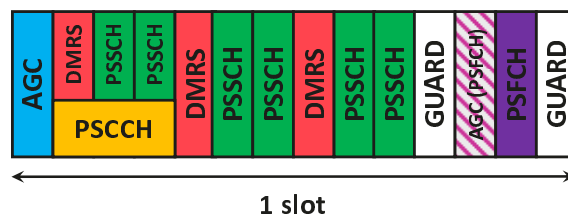

Figure 6.2.1-1(b): Example slot format of 3-symbol PSCCH, 3-symbol PSSCH-DMRS, and PSFCH.

When used for HARQ purposes, PSFCH carries HARQ feedback over the sidelink from a UE which is an intended recipient of a PSSCH transmission (henceforth an Rx UE) to the UE which performed the transmission (henceforth a Tx UE). Sidelink HARQ feedback may be in the form of conventional ACK/NACK, or NACK-only with nothing transmitted in case of successful decoding; for more information refer to clause 6.2.4. PSFCH can also convey inter-UE coordination information; refer to clause 6.8.

PSFCH transmits a Zadoff-Chu sequence in one PRB repeated over two OFDM symbols, the first of which can be used for AGC, near the end of the sidelink resource in a slot. The time resources for PSFCH are (pre-)configured to occur once in every 1, 2, or 4 slots. Frequency/code resources are derived implicitly from those used by the associated PSSCH transmission, together with the L1 identity of the UE transmitting PSSCH and, when groupcast with ACK/NACK feedback is used, the identity within the group of the UE transmitting PSFCH.

## 6.2.2 Sidelink synchronization

### 6.2.2.1 Synchronization references and priorities

There are four basic sources, or references, from which a V2X UE can derive its own synchronization: GNSS, a gNB/eNB, another UE transmitting SLSS (here termed a SyncRef UE), or its own internal clock. In general, GNSS or eNB/gNB are regarded as the highest-quality sources. SyncRef UEs are distinguished between those which are directly synchronized to GNSS or a gNB/eNB, those which are 1 further step away, and those which are  $\geq 2$  further steps away from GNSS or gNB/eNB. As a last resort, a UE unable to find any other synchronization reference will use its own internal clock to transmit S-SSB. The V2X synchronization procedure defines a hierarchy or set of priorities among such synchronization references and requires all UEs to continuously search the hierarchy to get to the highest-quality one they can find. The general preference order is as follows, with details specified in TS 38.331 [17, clause 5.8.6]:

- Level 1. Either GNSS or eNB/gNB, according to (pre-)configuration.
- Level 2. A SyncRef UE directly synchronized to a Level 1 source.
- Level 3. A SyncRef UE synchronized to a Level 2 source, i.e. indirectly synchronized to a Level 1 source.
- Level 4. Whichever of GNSS or eNB/gNB was not (pre-)configured as the Level 1 source.
- Level 5. A SyncRef UE directly synchronized to a Level 4 source.
- Level 6. A SyncRef UE synchronized to a Level 5 source, i.e. indirectly synchronized to a Level 4 source.
- Level 7. Any other SyncRef UE.
- Level 8. UE's internal clock.

The NR V2X scheme is intended to allow the merging of otherwise-separate hierarchies derived from GNSS and gNB/eNB, so that a UE is able to move between nearby such hierarchies without loss of sidelink service. However, since it is possible that a gNB/eNB does not itself have synchronization to GNSS, use of Levels 4-6 can be disabled when GNSS is used as Level 1, so that there is no deviation from the hierarchy being derived from GNSS.

### 6.2.2.2 S-SSB and SLSS

S-PSS and S-SSS use the same types of sequence as NR PSS and SSS respectively, i.e. an  $M$ -sequence and a Gold sequence. When in use, both sequences are transmitted in 127 subcarriers of the S-SSB bandwidth, in the same slots as PSBCH. S-PSS is in the 2nd and 3rd symbols of the slot, S-SSS is in the 4th and 5th symbols, and PSBCH and its DMRS in each of the remaining symbols. The two symbols of each synchronization signal are the same, which allows detectors to benefit from phase tracking between the two symbols. Figure 6.2.2.2-1 shows the contents of a slot containing S-SSB, the frequency location of which is (pre-)configured.

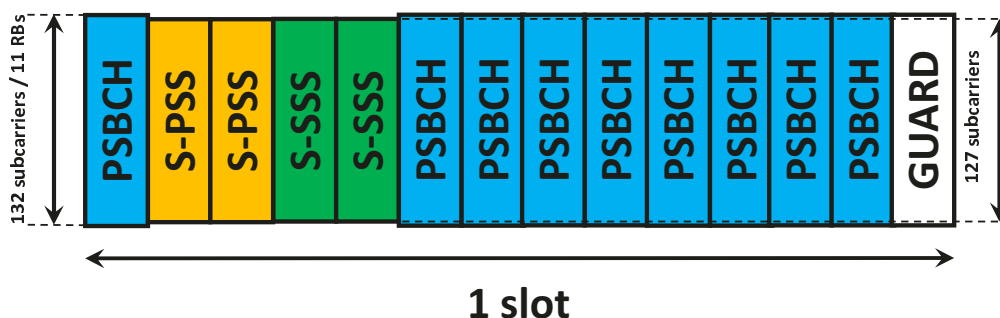

**Figure 6.2.2.2-1: Contents of a slot containing S-SSB for normal CP. Each PSBCH symbol contains DMRS.**

The MIB-V2X is transmitted on PSBCH every 160 ms, and thus S-SSB occurs on the same period. Within a period, there can be multiple transmissions of S-SSB, with the number depending on subcarrier spacing and frequency range. For details refer to TS 38.213 [18, clause 16.1].

#### 6.2.2.2.1 SLSSID

The SLSSID itself conveys information about the synchronization source of the transmitting UE. In general, the further a UE is away from a high-quality source of GNSS or gNB/eNB, the lower quality will be its own synchronization and thus the quality of an SLSS it transmits. There are a series of association rules among SLSS IDs, designed to allow the identification, and propagation through the system of, high-quality synchronization sources. The operation of this procedure is essentially the same as LTE-V2X, described in Clause 5.1.2.2.1, with the main difference that there are 672 SLSS IDs in NR-V2X, divided into 0, 1, ..., 335 for in-coverage indication and 336, ..., 671 for out-of-coverage indication. The special SLSS IDs of 0, 336, and 337 in NR-V2X are used equivalently to 0, 168, and 169 respectively in LTE-V2X.

### 6.2.3 Sidelink CSI

To provide the Tx UE with information it can use for sidelink link adaptation and rank adaptation in unicast transmissions, the Tx UE can configure aperiodic sidelink CSI reporting from the Rx UE. CQI and RI are reported via MAC layer signalling, in a PSSCH transmission. Calculation of the reported values is performed on sidelink CSI-RS from the Tx UE, which are a simplified subset of the Uu CSI-RS design, suitable for 1 or 2 antenna ports. The CSI report is transmitted by the Rx UE within a latency bound that is configured via PC5-RRC by the Tx UE, to ensure the report is timely with respect to the latency characteristic of the Tx UE's data traffic. The Tx UE must wait to trigger the next CSI report from a given Rx UE until the preceding report has been received, or its latency bound has expired.

### 6.2.4 Sidelink HARQ

NR-V2X supports HARQ based on transmission of ACK/NACK (or DTX) for sidelink unicast and groupcast services, as well as a NACK-only HARQ scheme particular to groupcast services. In addition, it supports blind re-transmission schemes, which are described in clauses 6.3.2.1 and 6.3.2.2 on resource allocation modes 1 and 2, respectively.

When ACK/NACK (or DTX) operation is used, the sidelink HARQ procedure is similar to the Uu scheme for non-codeblock group feedback, i.e. the HARQ feedback is transmitted based on the success or failure of the whole transport block.

NACK-only operation is defined for groupcast to allow a potentially lower sidelink resource demand to be created when a larger number of Rx UEs need to send feedback to the same Tx UE. A typical use case is an extended sensors scenario where UEs within a given radius all receive the same sensor information from the Tx UE, and re-transmission will occur if any UE fails to decode successfully. Since such information may only be relevant within a given radius around the Tx UE (e.g. a few tens or hundreds of meters around a road junction), the transmission of NACK-only feedback can be restricted to UEs within such a radius, and any UE beyond it does not provide any HARQ feedback. The minimum range requirement of a service is provided together with the associated QoS parameters from service layers.

One bit of sidelink HARQ feedback is carried on PSFCH from an Rx UE to its Tx UE. In addition, when under the control of a gNB in resource allocation mode 1, the Tx UE informs the gNB via PUCCH or PUSCH of the status of the sidelink HARQ feedback it has computed related to a particular dynamic or configured grant to assist the scheduling of re-transmissions and allocation of sidelink resources.

### 6.2.5 In-device coexistence between LTE-V2X and NR-V2X sidelinks

It is envisaged that there will exist devices that support both LTE-V2X and NR-V2X, and which will be operating in both systems concurrently. If the two RATs are widely spaced in frequency, e.g. being in different bands, then there need be no particular issues to consider since it is assumed that a separate RF chain will be provided for each band.

If, however, a sufficiently close frequency spacing is deployed, then it is desirable to enable a single RF chain to be used in the implementation, and also to adhere to the sidelink half-duplex principle established in LTE-V2X, i.e. that the UE is not required to simultaneously transmit and receive on sidelink. The former constraint means that interference between the two RATs' receptions can occur in the device if they are placed sufficiently close together in the frequency domain, and that simultaneous transmission on both RATs is prevented by the UE's single power budget. The latter constraint implies that one RAT cannot be received/transmitted while the other RAT is doing the opposite.

It is possible to (pre)-configure the resource pools for the two sidelinks such that overlapping is avoided entirely. When this is not arranged, the general rule is that (at least) one of the RATs may be dropped at times when both occur simultaneously, but that in some cases where the priority of the V2X service on both RATs is known, the higher priority one is automatically selected:



- Receive/receive overlap handling is always left to UE implementation decision.
- Transmit/transmit overlap handling and transmit/receive overlap handling will automatically select the RAT with the highest priority service if both priorities are known. If the priorities are equal or not both known, the handling is left to UE implementation to decide.

In the above rules, the priority of transmission and reception of sidelink synchronization signals/channels is set by (pre-)configuration and that of PSFCH is the same as the corresponding PSSCH.

## 6.2.6 Concurrent operation

NR-V2X operation is defined in bands n38, n47 and n79 in TS 38.101-1 [22, clause 5.2E], which support single-carrier operation:

**Table 6.2.6-1: NR-V2X operating bands**

V2X Operating Band	Sidelink (SL) Transmission operating band	Sidelink (SL) Reception operating band	Duplex Mode	Interface
	F <sub>UL_low</sub> - F <sub>UL_high</sub>	F <sub>DL_low</sub> - F <sub>DL_high</sub>		
n38 <sup>1</sup>	2570 MHz - 2620 MHz	2570 MHz - 2620 MHz	HD	PC5
n47	5855 MHz - 5925 MHz	5855 MHz - 5925 MHz	HD	PC5
n79	4400 MHz - 5000 MHz	4400 MHz - 5000 MHz	HD	PC5

Note 1: When this band is used for V2X SL service, the band is exclusively used for NR V2X in particular regions.

The NR-V2X sidelink in band n38 can be operated concurrently with LTE Uu band 20. The NR-V2X sidelink in band n47 can be operated concurrently with Uu bands 1, 3, 8, 39, 40, 41, n1, n8, n39, n40, n41, n71, n78, and n79. The NR-V2X sidelink in band n79 can be operated concurrently with Uu band n79.

## 6.3 V2X sidelink resource allocation

### 6.3.1 Sidelink bandwidth parts and resource pools

#### 6.3.1.1 Sidelink bandwidth parts

BWPs are defined for the sidelink in a similar way as for UL/DL, to provide a convenient way to specify aspects relating to a UE's RF hardware chain implementation. A UE is configured with one active sidelink BWP when in connected mode to a gNB, which is the same as the single sidelink BWP used for idle mode or out-of-coverage operation.

The subcarrier spacing used on sidelink is provided in the sidelink BWP (pre-)configuration, from the same set of values and associations to frequency ranges as for the Uu interface (i.e. 15, 30, or 60 kHz for FR1; and 60 or 120 kHz for FR2). Sidelink transmission and reception for a UE are thus contained within a sidelink BWP, and the same sidelink BWP is used for both transmitting and receiving. This means that resource pools, S-SSB, etc. must also be contained within an appropriate sidelink BWP from the UE's perspective.

#### 6.3.1.2 Resource pools

PSCCH and PSSCH resources are defined within resource pools for the respective channels. This concept is used because in general PSCCH/PSSCH cannot be transmitted (and thus are not expected to be received) in all RBs and slots in the NR system bandwidth, nor within the frequency span configured for V2X sidelink. The notion of a resource pool also reflects, in resource allocation mode 2, that a UE will make its resource selections based on sensing within the pool.

A resource pool is divided into sub-channels in the frequency domain, which are consecutively non-overlapping sets of  $\geq 10$  PRBs in a slot, the size depending on (pre-)configuration. Resource allocation, sensing, and resource selection are performed in units of a sub-channel. The UE's PSCCH occupies a (pre-)configurable number of PRBs within one sub-channel, starting from the lowest PRB of the PSSCH it schedules.

Within the slots that can be used for PSSCH transmission, there can be from 7 to 14 of the symbols reserved for sidelink operation, of which PSSCH can be transmitted in 5 to 12 symbols. The remaining sidelink symbols transmit some or all of PSCCH, PSFCH, AGC symbol(s), guard symbol(s). Refer to Figure 6.2.1-1 for examples of slot formats.

Resource pools are (pre-)configured to a UE separately from the transmission perspective (TX pools) and the reception perspective (RX pools). This allows a UE to monitor for PSCCH, and hence receive PSSCH transmissions, in resource pools other than those in which it transmits, so that it can attempt to receive transmissions made by other UEs in those RX pools.

In addition, there are exceptional resource pools configured to a UE, in its serving cell's broadcast or in dedicated signalling. These can be used e.g. during RLF in some cases, handover, transition from RRC IDLE to RRC CONNECTED, or during change of dedicated V2X sidelink resource pools within a cell. In these cases, a UE may not have a stable configuration of TX resource pools but nevertheless should not be removed from the V2X system, and so it can randomly select resources in the exceptional pool, and use them temporarily. Likewise, UEs need to monitor the exceptional TX pools for PSCCH transmissions.

## 6.3.2 Resource allocation modes

### 6.3.2.1 Mode 1

Mode 1 is for resource allocation by gNB. As described in Clause 4, the use cases intended for NR V2X can generate a diverse array of periodic and aperiodic message types. Therefore, resource allocation mode 1 provides dynamic grants of sidelink resources from a gNB, as well as grants of periodic sidelink resources configured semi-statically by RRC, termed sidelink configured grants.

A dynamic sidelink grant DCI can provide resources for one or multiple transmissions of a transport block, in order to allow control of reliability. The transmission(s) can be subject to the sidelink HARQ procedure, if that operation is enabled.

A sidelink configured grant can be such that it is configured once and can be used by the UE immediately, until it is released by RRC signalling (known as Type 1). A UE is allowed to continue using this type of sidelink configured grant when beam failure or physical layer problems occur in NR Uu until an RLF detection timer expires, before falling back to an exception resource pool. The other type of sidelink configured grant, known as Type 2, is configured once but cannot be used until the gNB sends the UE a DCI indicating it is now active, and only until another DCI indicates de-activation. The resources in both types are a set of sidelink resources recurring with a periodicity which a gNB will desire to match to the characteristics of the V2X traffic. Multiple configured grants can be configured, to allow provision for different services, traffic types, etc.

MCS information for dynamic and configured grants can optionally be provided or constrained by RRC signalling instead of the traditional DCI. RRC can configure the exact MCS the Tx UE uses, or a range of MCS. It may also be left unconfigured. For the cases where RRC does not provide the exact MCS, the transmitting UE is left to select an appropriate MCS itself based on the knowledge it has of the TB to be transmitted and, potentially, the sidelink radio conditions.

The gNB scheduling activity is driven by the UE reporting its sidelink traffic characteristics to the gNB, or by performing a sidelink BSR procedure similar to that on Uu to request a sidelink resource allocation from gNB.

### 6.3.2.2 Mode 2

Mode 2 is for UE autonomous resource selection. Its basic structure is of a UE sensing, within a (pre-)configured resource pool, which resources are not in use by other UEs with higher-priority traffic, and choosing an appropriate amount of such resources for its own transmissions. Having selected such resources, the UE can transmit and re-transmit in them a certain number of times, or until a cause of resource reselection is triggered.

The mode 2 sensing procedure can select and then reserve resources for a variety of purposes reflecting that NR V2X introduces sidelink HARQ in support of unicast and groupcast in the physical layer. It may reserve resources to be used for a number of blind (re-)transmissions or HARQ-feedback-based (re-)transmissions of a transport block, in which case the resources are indicated in the SCI(s) scheduling the transport block. Alternatively, it may select resources to be used for the initial transmission of a later transport block, in which case the resources are indicated in an SCI scheduling a current transport block, in a manner similar to the LTE-V2X scheme (clause 5.2.2.2). Finally, an initial transmission of a transport block can be performed after sensing and resource selection, but without a reservation.

The first-stage SCIs transmitted by UEs on PSCCH indicate the time-frequency resources in which the UE will transmit a PSSCH. These SCI transmissions are used by sensing UEs to maintain a record of which resources have been reserved by other UEs in the recent past. When a resource selection is triggered (e.g. by traffic arrival or a re-selection trigger), the UE considers a sensing window which starts a (pre-)configured time in the past and finishes shortly before the trigger time. The window can be either 1100 ms or 100 ms wide, with the intention that the 100 ms option is particularly useful for aperiodic traffic, and 1100 ms particularly for periodic traffic. A sensing UE also measures the SL-RSRP in the slots of the sensing window, which implies the level of interference which would be caused and experienced if the sensing UE were to transmit in them. In NR-V2X, SL-RSRP is a (pre-)configurable measurement of either PSSCH-RSRP or PSCCH-RSRP.

The sensing UE then selects resources for its (re-)transmission(s) from within a resource selection window. The window starts shortly after the trigger for (re-)selection of resources, and cannot be longer than the remaining latency budget of the packet due to be transmitted. Reserved resources in the selection window with SL-RSRP above a threshold are excluded from being candidates by the sensing UE, with the threshold set according to the priorities of the traffic of the sensing and transmitting UEs. Thus, a higher priority transmission from a sensing UE can occupy resources which are reserved by a transmitting UE with sufficiently low SL-RSRP and sufficiently lower-priority traffic.

If the set of resources in the selection window which have not been excluded is less than a certain proportion of the available resources within the window, the SL-RSRP exclusion threshold is relaxed in 3 dB steps. The proportion is set by (pre-)configuration to 20%, 35%, or 50% for each traffic priority. The UE selects an appropriate amount of resources randomly from this non-excluded set. The resources selected are not in general periodic. Up to three resources can be indicated in each SCI transmission, which can each be independently located in time and frequency. When the indicated resources are for semi-persistent transmission of another transport block, the range of supported periodicities is expanded compared to LTE-V2X, in order to cover the broader set of envisioned use cases in NR-V2X.

Shortly before transmitting in a reserved resource, a sensing UE re-evaluates the set of resources from which it can select, to check whether its intended transmission is still suitable, taking account of late-arriving SCIs due, typically, to an aperiodic higher-priority service starting to transmit after the end of the original sensing window. If the reserved resources would not be part of the set for selection at this time ( $T_3$ ), then new resources are selected from the updated resource selection window. The cut-off time  $T_3$  is long enough before transmission to allow the UE to perform the calculations relating to resource re-selection.

The timeline of the sensing and resource (re-)selection windows with respect to the time of trigger  $n$ , are shown in Figure 6.3.2.2-2(a), and the effect of the possibility of re-evaluation before first use of the reservation in Figure 6.3.2.2-2(b).

There are a number of triggers for resource re-selection, several of which are similar to LTE-V2X in Clause 5.2.2.2. In addition, there is the possibility to configure a resource pool with a pre-emption function designed to help accommodate aperiodic sidelink traffic, so that a UE reselects all the resources it has already reserved in a particular slot if another nearby UE with higher priority indicates it will transmit in any of them, implying a high-priority aperiodic traffic arrival at the other UE, and the SL-RSRP is above the exclusion threshold. The application of pre-emption can apply between all priorities of data traffic, or only when the priority of the pre-empting traffic is higher than a threshold and higher than that of the pre-empted traffic. A UE does not need to consider the possibility of pre-emption later than time  $T_3$  before the particular slot containing the reserved resources.

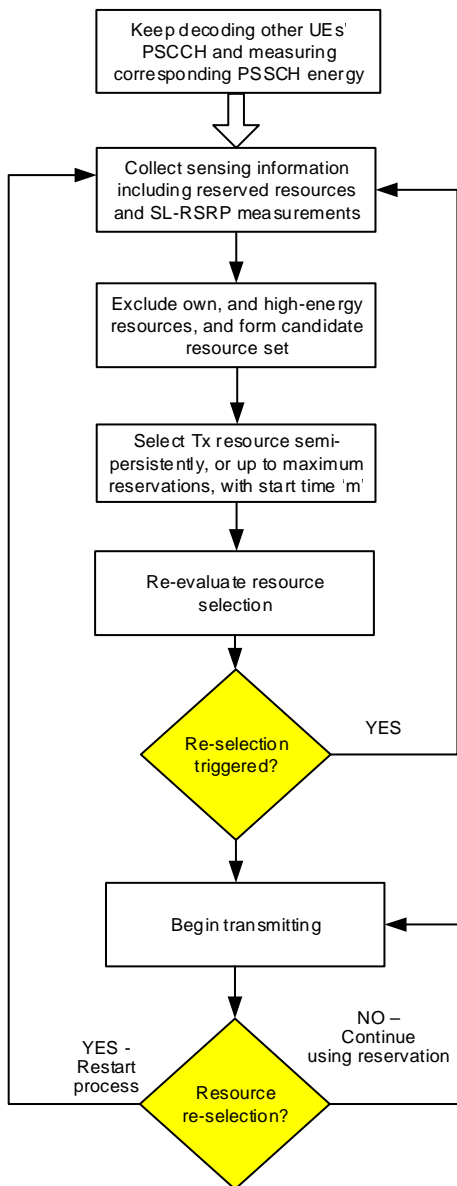

Figure 6.3.2.2-1: Summary of sensing and resource (re-)selection procedures

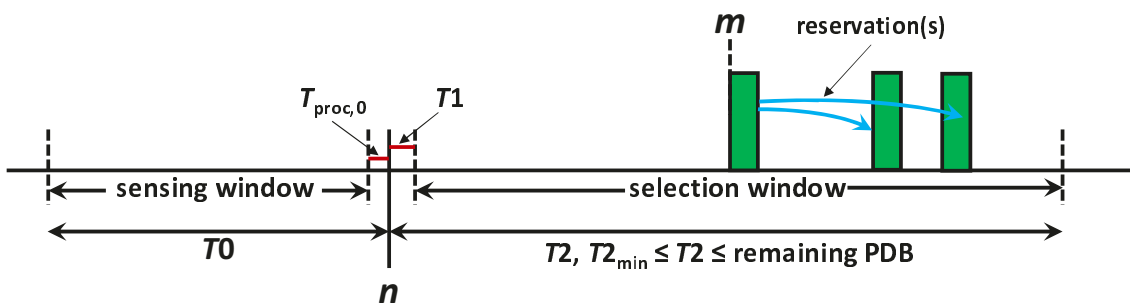

Figure 6.3.2.2-2(a): Timeline of sensing and resource (re-)selection procedure triggered at time  $n$ , without re-evaluation before  $(m - T_3)$ . Its first reserved resource is at time  $m$ .

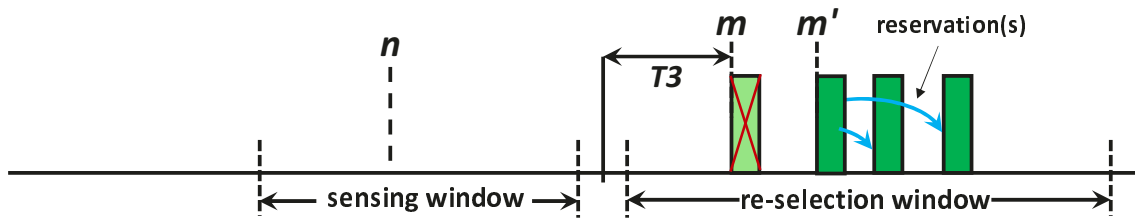

Figure 6.3.2.2-2(b): Timeline of sensing and resource (re-)selection procedure originally triggered at time  $n$ , which has a first reserved resource at time  $m$ , when re-evaluation occurring at  $m - T3$  determines the resources are no longer selectable. The new re-evaluation cut-off becomes  $(m' - T3)$ .

## 6.4 Sidelink congestion control

Congestion control for NR-V2X is similar to that described in Clause 5.3 for LTE-V2X, and it likewise is used in resource allocation mode 2 in NR. The main differences are that each packet is associated with a single 'priority' value, passed down to the physical layer from upper layers, which is comparable to PPPP in LTE-V2X. The priority value is transmitted in the first-stage SCI associated with each transport block. Broadly equivalent measurements of CBR and CR, together with CR-limits are defined, which can be used similarly to constrain the ranges of transmission parameters. NR V2X sets a shorter time of 1 ms or 2 ms in which the UE must calculate the CR and CBR than LTE-V2X's 4 ms, with the aim of adapting to faster fluctuations in congestion due to aperiodic traffic.

## 6.5 V2X sidelink higher-layer protocols

### 6.5.1 General

Figure 6.5.1-1 shows the user plane protocol stack for NR sidelink communication. The AS protocol stack of user plane in the PC5 interface consists of SDAP, PDCP, RLC, MAC, and the physical layer as shown below in Figure 6.5.1-1, from TS 38.300 [20, Clause 16.9.2.1].

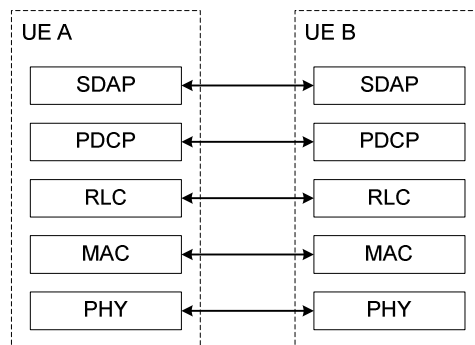
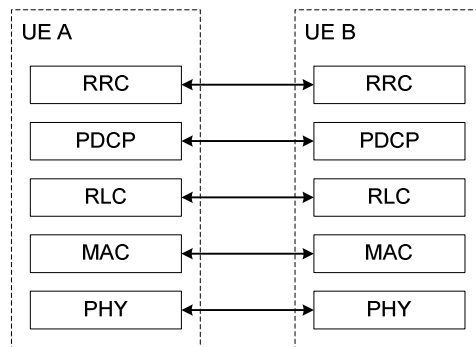

Figure 6.5.1-1: User plane protocol stack for STCH.

Figure 6.5.1-2 shows the control plane protocol stack for SCCH for RRC for NR sidelink communication. The AS protocol stack of the control plane for SCCH for RRC in the PC5 interface consists of RRC, PDCP, RLC, MAC and the physical layer as shown below in Figure 6.5.1-2, from TS 38.300 [20, Clause 16.9.2.1].



**Figure 6.5.1-2: Control plane (PC5-C) protocol stack for SCCH for RRC.**

Figure 6.5.1-3 shows the control plane protocol stack for PC-S. PC5-S is located on top of PDCP, RLC and MAC sublayers, and the physical layer for the control plane in the PC5 interface as shown in Figure 6.5.1-3, from TS 38.300 [20, Clause 16.9.2.1].

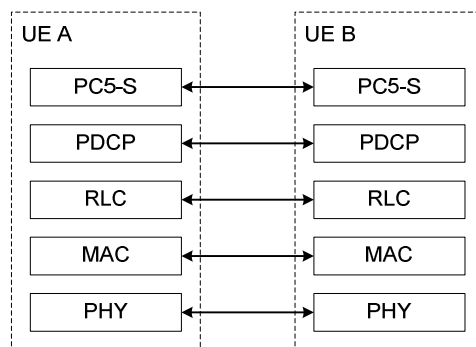

**Figure 6.5.1-3: Control plane (PC5-C) protocol stack for SCCH for PC5-S.**

The AS protocol stack for SBCCH in the PC5 interface consists of RRC, RLC, MAC sublayers, and the physical layer as shown below in Figure 6.5.1-4, from TS 38.300 [20, Clause 16.9.2.1].

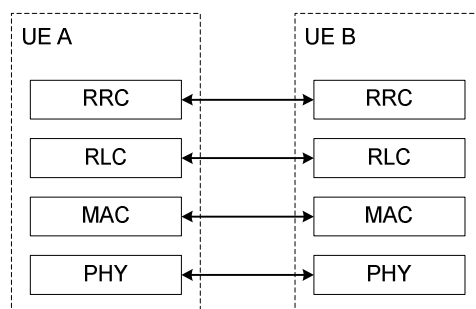

**Figure 6.5.1-4: Control plane protocol stack for SBCCH.**

## 6.5.2 Measurement and reporting related to NR sidelink communication

Some measurement and reporting mechanisms are supported specifically for NR sidelink communication, including CBR measurement and reporting to NG-RAN, reporting of location information to NG-RAN, and L3-filtered RSRP measurement and reporting in PC5 interface.

To provide some information to assist network's scheduling and/or transmission parameter adjustment, CBR measurement and reporting is performed for the RRC\_CONNECTED UEs.

To provide the Tx UE with information it can use for open loop power control in unicast transmissions, the Rx UE can perform RSRP measurement based on DMRS and report the L3-filtered RSRP to the Tx UE.

Details of the measurement and reporting mechanism specific for NR sidelink communication are specified in TS 38.331 [17, clause 5.5].

### 6.5.3 Mobility management for NR SL transmission/reception

UE can perform NR sidelink transmission and reception during handover and cell reselection. During handover, sidelink transmission and reception are performed based on configuration of the exceptional transmission resource pool or configured sidelink grant Type 1 and reception resource pool of the target cell as provided in the handover command.

Related details are specified in TS 38.331 [17, clause 5.8.8].

### 6.5.4 Assistance information and SL configured grant configuration

NG-RAN can allocate sidelink resources to UE with two types of configured sidelink grants (Type 1 and Type 2). For the UE performing NR sidelink communication, there can be more than one configured sidelink grant activated at a time on the carrier configured for sidelink transmission.

To provide assistance information for the configuration of configured grant, UE assistance information on traffic pattern can be reported to the network. The periodicity, time offset, message size, QoS info and destination can be included in the reporting message.

### 6.5.5 Coordination between UL and NR SL transmission

NR-UL/NR-SL prioritization is performed when the following scenarios occur:

- when UL TX overlaps in time domain with SL TX in the shared/same carrier frequency;
- when UL TX and SL TX (in different carrier frequency) share TX chains and power budget;

To support NR-UL/NR-SL prioritization, a separate LCH priority threshold is configured for both NR-UL and NR-SL. For SL data and UL data/SRB, the SL transmission is prioritized if the highest priority value of UL LCH(s) with available data is larger than the UL priority threshold and the highest priority value of SL LCH(s) with available data is lower than the SL priority threshold, otherwise the UL transmission is prioritized. Details of the prioritization between UL transmission and NR sidelink transmission are specified in TS 38.321 [21, clause 5.22.1.3].

The physical layer also provides prioritization and multiplexing rules between NR UL and NR SL when their transmissions would overlap, using rules similar to those from the Uu interface and relying on the priorities of the respective transmissions.

### 6.5.6 QoS mechanism

For NR sidelink communication, per flow based QoS model is used for sidelink unicast, groupcast and broadcast.

For RRC\_CONNECTED UEs, the UE may report the QoS information of the PC5 QoS flow via RRC dedicated signalling for transmission of a new PC5 QoS flow, and the network may provide SLRB configurations and configure the mapping of PC5 QoS flow to SLRB via RRC dedicated signalling, based on the QoS information reported by the UE.

For RRC\_IDLE/INACTIVE UEs, the network may provide SLRB configurations and configure the PC5 QoS profile to SLRB mapping via V2X-specific SIB.

For out of coverage UEs, SLRB configurations and the mapping of PC5 QoS profile to SLRB are pre-configured..

### 6.5.7 Sidelink RRC

For unicast NR sidelink communication, the PC5-RRC connection is a logical connection between a pair of source and destination L2 IDs.

The AS layer configuration including the parameters which need to be aligned between Tx UE and Rx UE can be conveyed via PC5 RRC signalling. In case AS layer configuration fails, both explicit failure message and timer based indication can be considered to be used to indicate the failure to the peer UE.

UE capability can be interacted between pair UEs via PC5 RRC. A UE can send Capability Enquiry message to request peer UE's capability along with its own capability information. When to include its own capabilities is up to UE implementation.

Moreover, SL RLM/RLF is supported for unicast NR sidelink communication. Upon RL RLF declaration, the UE releases the PC5 RRC connection immediately and sends an indication to upper layer. For RRC\_CONNECTED UEs, the UE also informs the network via sidelink UE information upon RLF is detected.

Details of the sidelink RRC procedures for NR sidelink communication are specified in TS 38.331 [17, clause 5.8.9].

## 6.6 V2X via the Uu interface

Some advanced V2X services are provided by an application server residing in the Internet which processes information received from the UE and issues instructions back to control the vehicle. Such applications can allow a remote driver or a V2X application to operate a remote vehicle for those passengers who cannot drive themselves. Other services, termed advanced driving, can incorporate video sharing among vehicles via an application server. In such applications, the communication is UE to/from the server via a cellular network's NR Uu interface.

Therefore, the Uu interface can activate multiple PUSCH configured grants (which are periodical resource grants configured by RRC, similar to LTE SPS in clause 5.5) simultaneously so that traffic sources with different requirements on latency, reliability, etc. can be handled at the same time. It is also possible for a PUSCH configured grant to send more than one PUSCH repetition in a slot or across a slot boundary, for the purpose of reducing UL latency.

## 6.7 Network aspects

### 6.7.1 V2X service authorization

Similarly as LTE V2X, the NG-RAN node receives the authorization status of the UE provided by a Core Network or a neighbour NG-RAN node, to know whether the UE is authorized as a Vehicle UE and/or a Pedestrian UE. Only the authorized UEs can perform V2X sidelink communication. Sidelink radio resources are provided to UEs in different ways according to the different services supported.

### 6.7.2 Alternative QoS Profiles

A list of alternative QoS parameter sets may be provided additionally for a GBR QoS Flow with Notification control enabled by the SMF to the NG-RAN node, or by the source NG-RAN node to the target NG-RAN node during handover.

The NG-RAN node, or the target NG-RAN node during handover, checks the requested QoS profile and the list of alternative QoS parameter sets. If one of the alternative QoS parameter sets can be fulfilled, it then indicates a reference to the fulfilled alternative QoS parameters set to the SMF and/or the source NG-RAN node.

## 6.8 Inter-UE coordination

NR-V2X UEs may exchange information with one another over sidelink which can aid the resource allocation mode 2 (re-)selection procedure.

There are two schemes for doing so, where UE-B has a sidelink transmission to perform and receives coordination information from UE-A:

1. A UE-A can provide to another UE-B indications of resources that are preferred to be included in UE-B's (re-)selected resources, or preferred to be excluded. When given resources to include, UE-B may rely only on those resources, at least if it does not support sensing/resource exclusion, or may combine them with resources identified by its own sensing procedure, before making a final selection.

Transmissions of, and requests for, coordination information are sent by UE-A or UE-B, respectively, in a MAC-CE and may also, if the UE supports the function, be sent in a 2nd-stage SCI. Coordination information can be in response to a request from UE-B, or due to an internal cause at UE-A. A request is sent in unicast to UE-A,



which responds also in unicast. When due to an internal cause, UE-A uses unicast to indicate resources preferred to be included, and unicast, groupcast or broadcast to indicate resources preferred to be excluded.

2. A UE-A can provide to another UE-B an indication that resources reserved for UE-B's transmission (which may or may not be to UE-A) will be, or could be, subject to conflict with a transmission from another UE. UE-B can then re-select new resources to replace them.

The indication from UE-A is a PSFCH sent to UE-B in resources which are (pre-)configured separately from those for SL-HARQ operation, and from which UE-B can derive which of its transmissions is indicated for re-selection.

In both schemes, UE-A can identify resources according to a number of conditions which are based on the SL-RSRP of the resources in question as a function of the traffic priority, and/or whether UE-A would be unable to receive a transmission from UE-B, due to performing its own transmission, i.e. a half-duplex problem. The purpose of this exchange of information is to give UE-B information about resource occupancy acquired by UE-A which it might not be able to determine on its own due to hidden nodes, exposed nodes, persistent collisions, etc.

## 7 Multi-RAT V2X

### 7.1 Cross-RAT operation

It is envisaged that NR-V2X and LTE-V2X will be at least initially deployed in similar timeframes, and also during a time when MNOs may have either or both of NR and LTE cellular networks available. An optional UE design response to this is supported where a device has both an LTE-V2X RAT and an NR-V2X RAT which are able to inter-communicate. This would enable the UE to perform sidelink communications with other UEs which implement only one of the sidelinks, and to do so whether they are in a cellular network of LTE or NR. Hence, for example, an LTE cellular network can be involved in controlling the NR sidelink via such dual-mode UEs, and an NR cellular network can similarly be involved in controlling LTE sidelink UEs.

LTE Uu can control NR resource allocation mode 1 by providing configured grant Type 1 configurations via LTE RRC signalling. This allows provision of periodically occurring sets of NR resources for the NR sidelink – see Clause 6.3.2.1. Control of NR resource allocation mode 2 is by LTE Uu RRC providing the semi-static configurations relevant to resource pools, sensing, etc. within which the NR-V2X RAT autonomously selects resources for sidelink transmission.

NR Uu can control LTE resource allocation mode 3 by transmitting an NR DCI which contains the information needed to dynamically control the LTE sidelink. The UE transfers this information internally to its LTE RAT, for which a certain amount of processing time is allowed, and then follows normal LTE sidelink procedures. Control of LTE resource allocation mode 4 is by NR Uu RRC providing the necessary semi-static configurations within which the LTE-V2X RAT autonomously selects resources for sidelink transmission.

Two separate sets of information for V2X services authorization can be signalled, i.e., the NR V2X Services Authorized IE, and the LTE V2X Services Authorized IE. These can be provided over the NG, S1, Xn, X2, and F1 interfaces, from the Core Network to the RAN node, between RAN nodes, and from gNB-CU to gNB-DU.

### 7.2 MR-DC

The scenarios for LTE V2X sidelink communication and NR sidelink communication are captured in the following figures. The scenarios can be categorized into standalone and MR-DC scenarios, according to TS 37.340 [19], regarding the architecture.

Figure 7.2-1, Figure 7.2-2 and Figure 7.2-3 illustrate the standalone scenarios to support LTE V2X sidelink communication and NR sidelink communication. Particularly:

- 1) In scenario 1, a gNB provides control/configuration for a UE's V2X communication in both LTE SL and NR SL;
- 2) In scenario 2, an ng-eNB provides control/configuration for a UE's V2X communication in both LTE SL and NR SL;
- 3) In scenario 3, an eNB provides control/configuration for a UE's V2X communication in both LTE SL and NR SL.

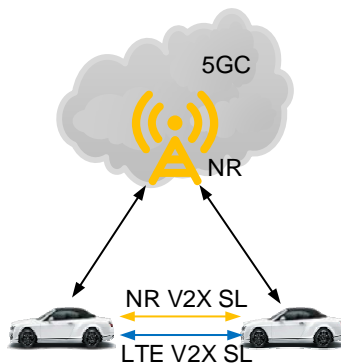

Figure 7.2-1: Scenario 1

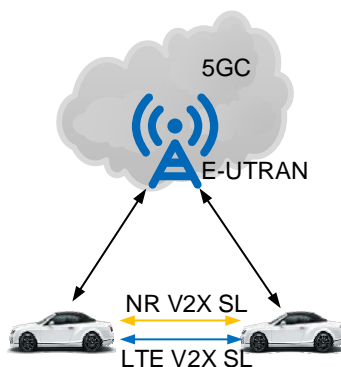

Figure 7.2-2: Scenario 2

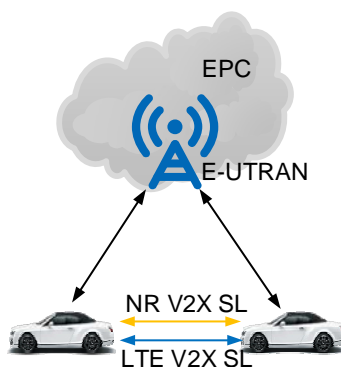

Figure 7.2-3: Scenario 3

Figure 7.2-4, Figure 7.2-5 and Figure 7.2-6 illustrate the MR-DC scenarios to support LTE V2X sidelink communication and NR sidelink communication. For the MR-DC scenario, MN controlling/configuring both NR SL and LTE SL in Scenarios 4, 5 and 6 is covered by Scenarios 1, 2 and 3 respectively. Particularly:

- 1) In scenario 4, a UE's V2X communication in LTE SL and NR SL is controlled/configured by Uu while the UE is configured with NE-DC;
- 2) In scenario 5, a UE's V2X communication in LTE SL and NR SL is controlled/configured by Uu while the UE is configured in NGEN-DC;
- 3) In scenario 6, a UE's V2X communication in LTE SL and NR SL is controlled/configured by Uu while the UE is configured in EN-DC.

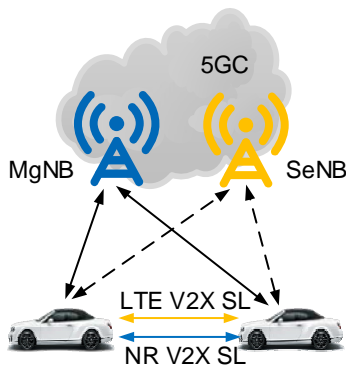

Figure 7.2-4: Scenario 4

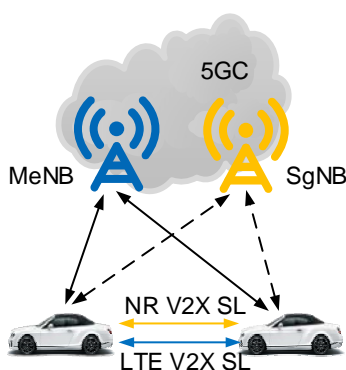

Figure 7.2-5: Scenario 5

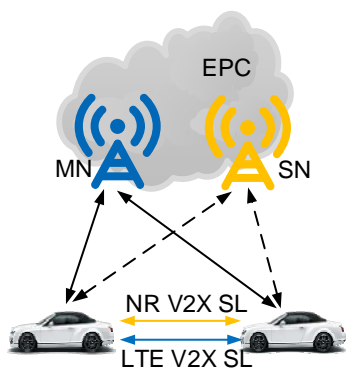

Figure 7.2-6: Scenario 6

## 8 Transmission profiles

LTE-V2X was developed over the course of two 3GPP Releases, Rel-14 and Rel-15. In Rel-15, non-backward compatible changes to physical transmission formats were introduced, primarily to support the use of 64-QAM on PSSCH compared to the maximum of 16-QAM in Rel-14. Such transmissions cannot be decoded by Rel-14 UEs. However, on sidelink, a transmitting UE cannot know the Release of specifications supported by the UEs which will receive the PSSCH transmission, since the transmission is broadcast in the physical layer. Therefore, the concept of transmission profiles was introduced, which associates to each transmission by a Rel-15 UE a (pre-)configuration of which Release's transmission format to use. A transmitting UE performs transmission format selection based on the profile indicated by higher layer of the 3GPP protocol stack. If a Rel-14 format is indicated, then the transmission can

be decoded by both Releases of UE, whereas if Rel-15 format is indicated, it can be decoded only by Rel-15 UEs. When a UE has traffic from different application sources to transmit at the same time, the transmission profile associated with the highest-priority traffic is applied. The association of transmission profiles to traffic sources (specifically, logical channels) is provided by 3GPP protocol layers outside of RAN.

Transmission profiles are also defined in NR, for the support of sidelink DRX, which was introduced in Rel-17; see Clause 9.3. This is to ensure compatibility for sidelink groupcast and broadcast between UEs supporting and not supporting sidelink DRX, since a receiver UE would miss transmissions sent in its DRX inactive times. Only if all those transmission profiles of interest to the receiver UE correspond to support of sidelink DRX does the UE assume it can be used. Similarly, a transmitting UE only assumes sidelink DRX is used by its groupcast or broadcast receiver UEs when the relevant transmission profile corresponds to support of sidelink DRX.

---

## 9 Battery-limited UEs

### 9.1 Power supply

LTE-V2X, as discussed in Clause 4, and NR-V2X both include communications between Pedestrian UEs and Vehicular UEs, i.e. V2P. Whereas a vehicular UE is assumed to be attached to the vehicle's power supply, and thus to have no particular battery life concerns, the situation is different for a P-UE and, more generally, a vulnerable road user (VRU). A VRU could be, e.g. a conventional smartphone running suitable applications, or a specialised device attached to a pedestrian's clothing, etc. In either case, battery life has to be considered so that the device will provide the V2P or VRU services for a reasonable length of time without need of re-charging, and without imposing such battery drain that associated applications could become unattractive.

### 9.2 Partial sensing

As described in Clause 5.2.2.2, a LTE-V2X UE performs sensing continuously in a 1000 ms historical window, implying an amount of ongoing power consumption due to the sensing procedure. It is allowed for a LTE P-UE to not support sidelink reception, so that it is only broadcasting packets relating to its own location and direction. This type of P-UE is allowed, if a resource pool's (pre-)configuration permits, to select transmission resources randomly, with no sensing procedure. For a LTE P-UE which does support sidelink reception, it can be permitted by (pre-)configuration to perform partial sensing. In partial sensing, only a subset of the subframes in the typically 1000 ms sensing window have to be monitored. The LTE UE implementation can choose how few subframes it wishes to monitor, by trading off the reliability of its transmissions with the power saving, subject to monitoring a (pre-)configured minimum number. (Pre-)configuration can also set how far into the past the sensing window extends, and can require that the UE performs partial sensing in a number of these truncated sensing windows.

In NR-V2X, there are two similar power-saving resource allocation methods which, as well as being applicable to P-UEs and VRUs, are also intended to have applicability to non-V2X applications. As with LTE-V2X, a UE is allowed, if a resource pool's (pre-)configuration permits, to select transmission resources randomly, with no sensing procedure. To retain the higher reliability provided by sidelink HARQ, the resources selected must still obey the constraints of HARQ feedback preparation time, and allow successive re-transmission resources to be signalled in the reach of one SCI.

For partial sensing in NR-V2X, there is a need to account for the wider set of targeted periodicities, and also for aperiodic traffic. Partial sensing therefore has two parts: periodic-based (PBPS), and contiguous (CPS). PBPS is similar to the LTE-V2X partial sensing, where a UE chooses a set of  $Y$  candidate slots, subject to a minimum number, and monitors that set. The UE can be (pre-)configured to monitor the  $Y$  slots at least according to a subset or the whole set of periodicities configured in the resource pool. When traffic arrives at slot  $n$ , sensing information from either the most recent one, or the most recent two, monitoring occasions of  $Y$  slots at each relevant periodicity is used in performing resource (re-)selection. PBPS is designed to provide sufficient sensing information to manage resource allocation for periodic traffic, whilst providing configurability to balance sensing accuracy with power consumption. On its own, PBPS may not be sufficient for detecting aperiodic traffic. For this purpose, CPS is performed in each of at least  $M$  sidelink slots ending shortly before the first of the  $Y$  candidates.  $M$  can be (pre-)configured to balance detection of aperiodic SCIs with UE power consumption. An example of this combined PBPS and CPS operation is shown in Figure 9.1. It is also possible for the UE to perform only CPS, if the resource pool does not permit periodic reservations.

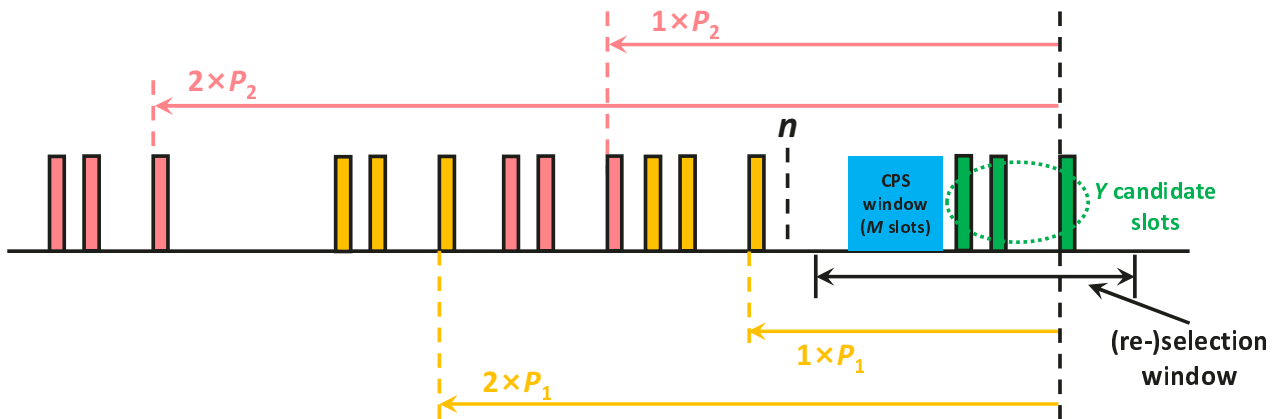

**Figure 9.1: Example of NR partial sensing. PBPS of  $Y$  candidate slots at two periodicities,  $P_1$  and  $P_2$ , for the two most recent PBPS occasions before slot  $n$ , and CPS for  $M$  sidelink slots ending a processing time before the  $Y$  candidate slots.**

For partial sensing applied to periodic transmissions, re-evaluation and pre-emption are also performed before the resources are used (see Clause 6.3.2.2) for the remaining PBPS candidate slots, and CPS slots preceding them.

## 9.3 Sidelink DRX

To aid in power consumption reduction for P-UEs, as well as other applications, NR-V2X supports DRX operation on sidelink. It is similar to DRX on the Uu interface, with DRX active and inactive times occurring on a periodically-repeating cycle. In the DRX active part of the cycle, full or partial sensing is performed as usual, together with reception and decoding of PSCCH, PSSCH, etc. In the DRX inactive part, a UE only performs reception of PSCCH and SL-RSRP measurements for sensing. When resource (re-)selection is performed, the physical layer ensures that at least a subset of the resources reported to the MAC layer are within the active time of the UE to which the intended transmission will be sent.

Sidelink DRX is supported for unicast, groupcast, and broadcast. For unicast, sidelink DRX is configured per pair of source L2 ID and destination L2 ID. A receiver UE may send assistance information to the transmitter UE to assist the determination of the sidelink DRX configuration for the receiver UE. The receiver UE may accept or reject the configuration via PC5-RRC signalling.

For groupcast and broadcast, sidelink DRX is configured based on QoS profile and destination L2 ID with multiple configurations supported. UE needs to perform down selection on cycle/timers when multiple QoS profiles are configured for one destination L2 ID. A default sidelink DRX configuration can be used for a QoS profile which cannot be mapped to any configuration for the dedicated QoS profile(s). Transmission profiles are defined for groupcast and broadcast to ensure backward compatibility; refer to Clause 8. A transmission profile is indicated from upper layers to AS layers, and includes at least the information of whether or not sidelink DRX is supported.

Alignment of Uu DRX and sidelink DRX for a receiver UE in RRC\_CONNECTED state is supported for unicast, groupcast, and broadcast.

Details of the sidelink DRX operation are specified in TS 38.321 [21, clause 5.28].

## 10 Roadside unit

The development of LTE and NR V2X contemplates three entities in the network: base stations, i.e. eNBs and gNBs; UEs; and RSUs. An RSU is defined in TS 22.185 [6], TS 22.186 [7] as a stationary infrastructure entity supporting V2X applications that can exchange messages with other entities supporting V2X applications. Note that RSU is a term frequently used in existing ITS specifications, and the reason for introducing the term in the 3GPP specifications is to make the documents easier to read for the ITS industry. RSU is a logical entity that supports V2X application logic using the functionality provided by either a 3GPP network (referred to as an eNB/gNB-type RSU) or a UE (referred to as UE-type RSU).

Since an RSU is essentially only different from a eNB/gNB or UE in terms of its deployment nature, e.g. it may be deployed by a national roads authority instead of an MNO, there is no specification of features particular to RSUs. They operate simply according to sidelink or UL/DL specifications as appropriate.

## Annex <A> (informative): Change history

Change history							
Date	Meeting	TDoc	CR	Rev	Cat	Subject/Comment	New version
2019-05	RAN1#97	R1-1906663				Initial version of TR and skeleton of LTE-V2X clauses	0.0.1
2019-08	RAN1#98	R1-1909651				LTE-V2X first version, and skeleton of NR-V2X clauses	0.1.0
2019-10	RAN1#98bis	R1-1910616				Addition of RAN2 and RAN3 LTE-V2X, and NR-V2X first version	0.2.0
2019-11	RAN1#99	R1-1913120				RAN2 NR V2X skeleton and updates to RAN1 NR V2X clauses	0.3.0
2019-11	RAN1#99	R1-1913587				V1.0.0 to RAN for information	1.0.0
2020-02	RAN1#100-e	R1-2001223				Updates to NR V2X clauses; addition of introduction and scope	1.1.0
2020-04	RAN1#100bis-e	R1-2002762				Updates and refinements after RAN1#100-e	1.2.0
2020-05	RAN1#101-e	R1-2004861				Updates and refinements after RAN1#100bis-e	1.4.0
2020-06	RAN#88-e	RP-200708				V2.0.0 (endorsed by RAN1#101-e in R1-2005121) to RAN for approval	2.0.0
2020-06	RAN#88-e	-				TR37.985 is approved and under change control as a Rel-16 spec	16.0.0
2021-12	RAN#94-e	RP-212978	0001	-	B	Introduction of Rel-17 sidelink enhancements	17.0.0
2022-03	RAN#95-e	RP-220245	0003	-	A	Addition of Rel-16 NR V2X bands to TR 37.985	17.1.0
2022-03	RAN#95-e	RP-220262	0004	-	F	Introduction of Rel-17 sidelink enhancements and concurrent Uu-PC5 bands	17.1.0
2022-03	RAN#95-e	-	-	-	-	MCC editorial fixing an oversight in cross-reference issue in clause 9.3 of version 17.1.0 – reference is changed to TS 38.321 [21, clause 5.28]	17.1.1

---

# History

<b>Document history</b>		
V17.1.1	April 2022	Publication