



5G;
Study on 5G NR User Equipment (UE)
application layer data throughput performance
(3GPP TR 37.901-5 version 16.4.0 Release 16)



Reference

RTR/TSGR-0537901-5vg40

Keywords

5G

ETSI

650 Route des Lucioles
F-06921 Sophia Antipolis Cedex - FRANCE

Tel.: +33 4 92 94 42 00 Fax: +33 4 93 65 47 16

Siret N° 348 623 562 00017 - NAF 742 C
Association à but non lucratif enregistrée à la
Sous-Préfecture de Grasse (06) N° 7803/88

Important notice

The present document can be downloaded from:

<http://www.etsi.org/standards-search>

The present document may be made available in electronic versions and/or in print. The content of any electronic and/or print versions of the present document shall not be modified without the prior written authorization of ETSI. In case of any existing or perceived difference in contents between such versions and/or in print, the prevailing version of an ETSI deliverable is the one made publicly available in PDF format at www.etsi.org/deliver.

Users of the present document should be aware that the document may be subject to revision or change of status.

Information on the current status of this and other ETSI documents is available at

<https://portal.etsi.org/TB/ETSIDeliverableStatus.aspx>

If you find errors in the present document, please send your comment to one of the following services:

<https://portal.etsi.org/People/CommitteeSupportStaff.aspx>

Copyright Notification

No part may be reproduced or utilized in any form or by any means, electronic or mechanical, including photocopying and microfilm except as authorized by written permission of ETSI.

The content of the PDF version shall not be modified without the written authorization of ETSI.

The copyright and the foregoing restriction extend to reproduction in all media.

© ETSI 2021.

All rights reserved.

DECT™, **PLUGTESTS™**, **UMTS™** and the ETSI logo are trademarks of ETSI registered for the benefit of its Members.

3GPP™ and **LTE™** are trademarks of ETSI registered for the benefit of its Members and of the 3GPP Organizational Partners.

oneM2M™ logo is a trademark of ETSI registered for the benefit of its Members and of the oneM2M Partners.

GSM® and the GSM logo are trademarks registered and owned by the GSM Association.

Intellectual Property Rights

Essential patents

IPRs essential or potentially essential to normative deliverables may have been declared to ETSI. The information pertaining to these essential IPRs, if any, is publicly available for **ETSI members and non-members**, and can be found in ETSI SR 000 314: "*Intellectual Property Rights (IPRs); Essential, or potentially Essential, IPRs notified to ETSI in respect of ETSI standards*", which is available from the ETSI Secretariat. Latest updates are available on the ETSI Web server (<https://ipr.etsi.org/>).

Pursuant to the ETSI IPR Policy, no investigation, including IPR searches, has been carried out by ETSI. No guarantee can be given as to the existence of other IPRs not referenced in ETSI SR 000 314 (or the updates on the ETSI Web server) which are, or may be, or may become, essential to the present document.

Trademarks

The present document may include trademarks and/or tradenames which are asserted and/or registered by their owners. ETSI claims no ownership of these except for any which are indicated as being the property of ETSI, and conveys no right to use or reproduce any trademark and/or tradename. Mention of those trademarks in the present document does not constitute an endorsement by ETSI of products, services or organizations associated with those trademarks.

Legal Notice

This Technical Report (TR) has been produced by ETSI 3rd Generation Partnership Project (3GPP).

The present document may refer to technical specifications or reports using their 3GPP identities. These shall be interpreted as being references to the corresponding ETSI deliverables.

The cross reference between 3GPP and ETSI identities can be found under <http://webapp.etsi.org/key/queryform.asp>.

Modal verbs terminology

In the present document "**should**", "**should not**", "**may**", "**need not**", "**will**", "**will not**", "**can**" and "**cannot**" are to be interpreted as described in clause 3.2 of the [ETSI Drafting Rules](#) (Verbal forms for the expression of provisions).

"**must**" and "**must not**" are **NOT** allowed in ETSI deliverables except when used in direct citation.

Contents

Intellectual Property Rights	2
Legal Notice	2
Modal verbs terminology.....	2
Foreword.....	8
1 Scope	10
2 References	10
3 Definitions of terms, symbols and abbreviations	11
3.1 Terms.....	11
3.2 Symbols.....	11
3.3 Abbreviations	11
4 General	11
4.1 Background	11
4.2 Study Item Objective.....	11
5 Study on 5G NR UE Application Layer Data Throughput Performance	12
5.1 Definition of Application Layer Data Throughput Performance.....	12
5.1.1 Definition of End Points	12
5.2 Parameters for Measurement.....	13
5.2.1 Throughput	13
5.3 Test Configurations	13
5.3.1 5G NR UE Application Layer Data Throughput Test Equipment	13
5.3.2 UE Application Layer Data Throughput Connection Diagrams	13
5.3.2.1 UE Application Layer Data Throughput Connection Diagram for Tethered	13
5.3.2.2 UE Application Layer Data Throughput Connection Diagram for Embedded	13
5.3.3 RF Connection Diagrams for UE Application Layer Data Throughput	14
5.3.4 UE Specific Items	14
5.4 Transport and Application Layer Protocols.....	14
5.4.1 Transport Layer Protocol	14
5.4.2 Application Layer Protocol.....	14
5.4.2.1 TCP Settings	15
5.4.2.1.1 TCP advertised receiver window size setting	16
5.4.2.2 UDP Settings.....	16
5.4.3 Upper Layer impact on throughput measurements	17
5.4.3.1 Overview.....	17
5.4.3.2 TCP/UDP Layer.....	18
5.4.3.3 IP Layer.....	18
5.4.3.4 PDCP Layer	18
5.4.3.5 RLC Layer.....	19
5.4.3.6 Overhead between MAC and TCP/UDP layer.....	19
5.4.3.7 Overhead for LTE	19
5.4.3.8 SA, NSA and NSA split-bearer.....	19
5.4.4 Summary of Upper Layer Parameters and Overhead from MAC to Transport Layer	19
5.5 Test Environment	20
5.5.1 Conducted Testing for 5G NR FR1	20
5.5.1.1 Signal Levels	20
5.5.1.2 Fading Profiles	20
5.5.2 Radiated Testing for 5G NR FR2	21
5.6 Data Transfer Scenarios	21
5.6.1 TCP Transfers.....	21
5.6.2 UDP Transfers	21
5.7 Statistical Analysis	21
5.7.1 Overview of Layer 1 throughput.....	21
5.7.2 Overview of Application Layer throughput.....	22
5.7.3 Test Time for Application Layer Throughput procedures	23

5.8	Impact of Modem Performance in Application Layer Throughput	23
5.8.1	Modem Performance in current TS 38.521-4 conformance tests.....	23
5.8.2	Modem Performance in Application Layer Data Throughput Tests	24
5.9	Test System Uncertainty and Test Tolerance	24
5.9.1	Test System Uncertainty and Test Tolerance for FR1 testing	24
5.9.1.1	Recommended Uncertainty of Test System	24
5.9.1.2	Test Tolerances	24
5.9.1.3	Impact of Test System Uncertainty on Test Results	24
5.9.2	Test System Uncertainty and Test Tolerance for FR2 testing	25
6	Conclusions	25
Annex A: Test Procedures.....		26
A.1	Purpose of annex	26
A.1.1	General	26
A.2	5G NR /TCP Downlink Throughput /Conducted/Static Peak Throughput for SA and NSA.....	27
A.2.1	5G NR /TCP Downlink Throughput /Conducted/Static Channel Peak Throughput tests for SA and NSA.....	27
A.2.1.1	5G NR /TCP Downlink Throughput /Conducted/Static Channel/ SA and NSA (no Downlink Split Bearer)	27
A.2.1.1.1	Definition	27
A.2.1.1.2	Test Purpose	27
A.2.1.1.3	Test Parameters	27
A.2.1.1.4	Test Description	28
A.2.1.1.4.1	Initial Conditions	28
A.2.1.1.4.2	Test Procedure	28
A.2.1.2	5G NR /TCP Downlink Throughput /Conducted/Static Channel/NSA (Downlink Split Bearer).....	29
A.2.1.2.1	Definition	29
A.2.1.2.2	Test Purpose	29
A.2.1.2.3	Test Parameters	29
A.2.1.2.4	Test Description	29
A.2.1.2.4.1	Initial Conditions	29
A.2.1.2.4.2	Test Procedure	30
A.3	5G NR /TCP Downlink Throughput /Conducted for Fixed Reference Channel (FRC) Scenarios with Fading for SA and NSA	30
A.3.1	5G NR /TCP Downlink Throughput /Conducted/Fading/FRC for SA and NSA.....	30
A.3.1.1	5G NR /TCP Downlink Throughput /Conducted/Fading/FRC/2Rx for SA and NSA.....	30
A.3.1.1.1	5G NR /TCP Downlink Throughput /Conducted/Fading/2Rx/FR1 PDSCH mapping Type A performance - 2x2 MIMO for SA and NSA.....	30
A.3.1.1.1.1	Definition.....	30
A.3.1.1.1.2	Test Purpose	30
A.3.1.1.1.3	Test Parameters	30
A.3.1.1.1.4	Test Description.....	31
A.3.1.1.2	5G NR /TCP Downlink Throughput /Conducted/Fading/2Rx TDD/FR1 PDSCH mapping Type A performance - 2x2 MIMO for SA and NSA.....	32
A.3.1.1.2.1	Definition.....	32
A.3.1.1.2.2	Test Purpose	32
A.3.1.1.2.3	Test Parameters	32
A.3.1.1.2.4	Test Description.....	33
A.3.1.2	5G NR /TCP Downlink Throughput /Conducted/Fading/FRC/4Rx for SA and NSA.....	33
A.3.1.2.1	5G NR /TCP Downlink Throughput /Conducted/Fading/FRC/4Rx FDD/FR1 PDSCH mapping Type A performance - for SA and NSA.....	33
A.3.1.2.1.1	Definition.....	33
A.3.1.2.1.2	Test Purpose	33
A.3.1.2.1.3	Test Parameters	34
A.3.1.2.2	5G NR /TCP Downlink Throughput /Conducted/Fading/FRC/4Rx TDD/FR1 PDSCH mapping Type A performance - for SA and NSA.....	35
A.3.1.2.2.1	Definition.....	35
A.3.1.2.2.2	Test Purpose	35
A.3.1.2.2.3	Test Parameters	35
A.3.1.2.2.4	Test Description.....	35

A.4	5G NR /UDP Downlink Throughput /Conducted/Static Peak Throughput for SA and NSA	36
A.4.1	5G NR /UDP Downlink Throughput /Conducted/Static Channel Peak Throughput tests for SA and NSA	36
A.4.1.1	5G NR /UDP Downlink Throughput /Conducted/Static Channel/ SA and NSA (no Downlink Split Bearer)	36
A.4.1.1.1	Definition	36
A.4.1.1.2	Test Purpose	36
A.4.1.1.3	Test Parameters	36
A.4.1.2	5G NR /UDP Downlink Throughput /Conducted/Static Channel/NSA (Downlink Split Bearer)	
A.4.1.2.1	Definition	38
A.4.1.2.2	Test Purpose	38
A.4.1.2.3	Test Parameters	38
A.4.1.2.4	Test Description.....	38
A.5	5G NR /UDP Downlink Throughput /Conducted for Fixed Reference Channel (FRC) Scenarios with Fading for SA and NSA	39
A.5.1	5G NR /UDP Downlink Throughput /Conducted/Fading/FRC for SA and NSA	39
A.5.1.1	5G NR /UDP Downlink Throughput /Conducted/Fading/FRC/2Rx for SA and NSA	39
A.5.1.1.1	5G NR /UDP Downlink Throughput /Conducted/Fading/2Rx/FR1 PDSCH mapping Type A performance - 2x2 MIMO for SA and NSA.....	39
A.5.1.1.1.1	Definition.....	39
A.5.1.1.1.2	Test Purpose	39
A.5.1.1.1.3	Test Parameters	40
A.5.1.1.2	5G NR /UDP Downlink Throughput /Conducted/Fading/2Rx TDD/FR1 PDSCH mapping Type A performance - 2x2 MIMO for SA and NSA.....	41
A.5.1.1.2.1	Definition.....	41
A.5.1.1.2.2	Test Purpose	41
A.5.1.1.2.3	Test Parameters	41
A.5.1.1.2.4	Test Description.....	42
A.5.1.2	5G NR /UDP Downlink Throughput /Conducted/Fading/FRC/4Rx for SA and NSA	42
A.5.1.2.1	5G NR /UDP Downlink Throughput /Conducted/Fading/FRC/4Rx FDD/FR1 PDSCH mapping Type A performance - 4x4 MIMO for SA and NSA.....	42
A.5.1.2.1.1	Definition.....	42
A.5.1.2.1.2	Test Purpose	42
A.5.1.2.1.3	Test Parameters	43
A.5.1.2.1.4	Test Description.....	43
A.5.1.2.2	5G NR /UDP Downlink Throughput /Conducted/Fading/4Rx TDD/FR1 PDSCH mapping Type A performance - 4x4 MIMO for SA and NSA.....	44
A.5.1.2.2.1	Definition.....	44
A.5.1.2.2.2	Test Purpose	44
A.5.1.2.2.3	Test Parameters	44
A.5.1.2.2.4	Test Description.....	45
A.6	5G NR /TCP Downlink Throughput/Radiated/Static Peak Throughput for SA and NSA.....	46
A.6.1	5G NR /TCP Downlink Throughput /Radiated/Static Channel Peak Throughput tests for SA and NSA	46
A.6.1.1	5G NR /UDP Downlink Throughput /Radiated/Static Channel/ SA and NSA (no Downlink Split Bearer)	46
A.6.1.1.1	Definition	46
A.6.1.1.2	Test Purpose	46
A.6.1.1.3	Test Parameters	46
A.6.1.1.4	Test Description	46
A.6.1.1.4.1	Initial Conditions	46
A.6.1.1.4.2	Test Procedure.....	46
A.7	5G NR /TCP Downlink Throughput /Radiated for Fixed Reference Channel Scenarios (FRC) with Fading.....	47
A.7.1	5G NR /TCP Downlink Throughput /Radiated/Fading/FRC	47
A.7.1.1	5G NR /TCP Downlink Throughput /Radiated/Fading/FRC/2Rx	47
A.7.1.1.1	5G NR /TCP Downlink Throughput /Radiated/Fading/2Rx TDD/FR2 PDSCH mapping Type A performance - for SA and NSA.....	47
A.7.1.1.1.1	Definition.....	47
A.7.1.1.1.2	Test Purpose	47
A.7.1.1.1.3	Test Parameters	47

A.7.1.1.1.4	Test Description.....	48
A.7.1.2	5G NR /TCP Downlink Throughput /Radiated/Fading/FRC/4Rx	49
A.7.1.2.1	5G NR /TCP Downlink Throughput /Radiated/Fading/FRC/4Rx/FR2 PDSCH mapping Type A performance - 4x4 MIMO	49
A.8	5G NR /UDP Downlink Throughput/Radiated/Static Peak Throughput for SA and NSA	50
A.8.1	5G NR /UDP Downlink Throughput /Radiated/Static Channel Peak Throughput tests for SA and NSA	50
A.8.1.1	5G NR /UDP Downlink Throughput /Radiated/Static Channel/ SA and NSA (no Downlink Split Bearer)	50
A.8.1.1.1	Definition	50
A.8.1.1.2	Test Purpose	50
A.8.1.1.3	Test Parameters	50
A.8.1.1.4	Test Description	50
A.8.1.1.4.1	Initial Conditions	50
A.8.1.1.4.2	Test Procedure	50
A.9	5G NR /UDP Downlink Throughput /Radiated for Fixed Reference Channel Scenarios (FRC) with Fading.....	51
A.9.1	5G NR /UDP Downlink Throughput /Radiated/Fading/FRC.....	51
A.9.1.1	5G NR /UDP Downlink Throughput /Radiated/Fading/FRC/2Rx.....	51
A.9.1.1.1	5G NR /UDP Downlink Throughput /Radiated/Fading/2Rx TDD/FR2 PDSCH mapping Type A performance - for SA and NSA.....	51
A.9.1.1.1.1	Definition.....	51
A.9.1.1.1.2	Test Purpose	51
A.9.1.1.1.3	Test Parameters	51
A.9.1.1.1.4	Test Description.....	52
A.9.1.2	5G NR /UDP Downlink Throughput /Radiated/Fading/FRC/4Rx.....	53
A.9.1.2.1	5G NR /UDP Downlink Throughput /Radiated/Fading/FRC/4Rx/FR2 PDSCH mapping Type A performance - 4x4 MIMO	53
A.9.1.2.1.1	Definition.....	53
A.9.1.2.1.2	Test Purpose	53
A.9.1.2.1.3	Test Parameters	53
A.9.1.2.1.4	Test Description.....	53
A.10	5G NR /TCP Downlink Throughput /Conducted for Variable Reference Channel (VRC) Scenarios with Fading for SA and NSA.....	54
A.10.1	5G NR /TCP Downlink Throughput /Conducted/Fading/VRC for SA and NSA	54
A.10.1.1	5G NR /TCP Downlink Throughput /Conducted/Fading/VRC/2Rx for SA and NSA	54
A.10.1.1.1	5G NR /TCP Downlink Throughput /Conducted/Fading/FRC/2Rx FDD /FR1 PDSCH mapping Type A performance - for SA and NSA	54
A.10.1.1.2	5G NR /TCP Downlink Throughput /Conducted/Fading/FRC/2Rx TDD /FR1 PDSCH mapping Type A performance - for SA and NSA.....	54
A.10.1.2	5G NR /TCP Downlink Throughput /Conducted/Fading/FRC/4Rx	54
A.10.1.2.1	5G NR /TCP Downlink Throughput /Conducted/Fading/VRC/4Rx FDD/FR1 PDSCH mapping Type A performance - for SA and NSA.....	54
A.10.1.2.2	5G NR /TCP Downlink Throughput /Conducted/Fading/VRC/4Rx TDD/FR1 PDSCH mapping Type A performance - for SA and NSA.....	54
A.11	5G NR /UDP Downlink Throughput /Conducted for Variable Reference Channel (VRC) Scenarios for SA and NSA	54
A.11.1	5G NR /UDP Downlink Throughput /Conducted/Fading/VRC	54
A.11.1.1	5G NR /UDP Downlink Throughput /Conducted/Fading/VRC/2Rx.....	54
A.11.1.1.1	5G NR /UDP Downlink Throughput /Conducted/Fading/VRC/2Rx FDD/FR1 PDSCH mapping Type A performance - for SA and NSA	54
A.11.1.1.2	5G NR /UDP Downlink Throughput /Conducted/Fading/VRC/2Rx TDD/FR1 PDSCH mapping Type A performance - for SA and NSA.....	55
A.11.1.2	5G NR /UDP Downlink Throughput /Conducted/Fading/VRC/4Rx.....	55
A.11.1.2.1	5G NR /UDP Downlink Throughput /Conducted/Fading/VRC/4Rx FDD/FR1 PDSCH mapping Type A performance - for SA and NSA.....	55
A.11.1.2.2	5G NR /UDP Downlink Throughput /Conducted/Fading/VRC/4Rx FDD/FR1 PDSCH mapping Type A performance - for SA and NSA.....	55

A.12	5G NR /TCP Downlink Throughput /Radiated for Variable Reference Channel Scenarios (VRC) with Fading.....	55
A.12.1	5G NR /TCP Downlink Throughput /Radiated/Fading/VRC.....	55
A.12.1.1	5G NR /TCP Downlink Throughput /Radiated/Fading/VRC/2Rx.....	55
A.12.1.2	5G NR /TCP Downlink Throughput /Radiated/Fading/VRC/4Rx.....	55
A.13	5G NR /UDP Downlink Throughput /Radiated for Variable Reference Channel (VRC) Scenarios	55
A.13.1	5G NR /UDP Downlink Throughput /Radiated/Fading/VRC	55
A.13.1.1	5G NR /UDP Downlink Throughput /Radiated/Fading/VRC/2Rx	55
A.13.1.2	5G NR /UDP Downlink Throughput /Radiated/Fading/VRC/4Rx	55
Annex B:	Specific Test Conditions and Environment	56
Annex C:	Specific Connection Diagrams	57
Annex D:	Reference Test Points	58
D.1	FR1 Reference Test Points	58
D.2	FR2 Reference Test Points	60
Annex E:	E-UTRA Anchor Configuration for NSA testing Diagrams	61
Annex F:	Embedded Data Client Recommendations	62
F.1	Purpose of annex	62
F.2	Embedded Data Client Automation.....	62
F.2.1	Embedded Data Client Functionality	62
F.2.2	Embedded Data Client Provisioning	62
F.2.3	Embedded Data Client Command Set and Operation	63
F.2.3.1	Poll for Task Command.....	63
F.2.3.2	Task List	63
F.2.3.3	Result Reporting	63
Annex G:	Applicability	64
Annex H:	Change history	65
History		66

Foreword

This Technical Report has been produced by the 3rd Generation Partnership Project (3GPP).

The contents of the present document are subject to continuing work within the TSG and may change following formal TSG approval. Should the TSG modify the contents of the present document, it will be re-released by the TSG with an identifying change of release date and an increase in version number as follows:

Version x.y.z

where:

- x the first digit:
 - 1 presented to TSG for information;
 - 2 presented to TSG for approval;
 - 3 or greater indicates TSG approved document under change control.
- y the second digit is incremented for all changes of substance, i.e. technical enhancements, corrections, updates, etc.
- z the third digit is incremented when editorial only changes have been incorporated in the document.

In the present document, modal verbs have the following meanings:

- shall** indicates a mandatory requirement to do something
- shall not** indicates an interdiction (prohibition) to do something

The constructions "shall" and "shall not" are confined to the context of normative provisions, and do not appear in Technical Reports.

The constructions "must" and "must not" are not used as substitutes for "shall" and "shall not". Their use is avoided insofar as possible, and they are not used in a normative context except in a direct citation from an external, referenced, non-3GPP document, or so as to maintain continuity of style when extending or modifying the provisions of such a referenced document.

- should** indicates a recommendation to do something
- should not** indicates a recommendation not to do something
- may** indicates permission to do something
- need not** indicates permission not to do something

The construction "may not" is ambiguous and is not used in normative elements. The unambiguous constructions "might not" or "shall not" are used instead, depending upon the meaning intended.

- can** indicates that something is possible
- cannot** indicates that something is impossible

The constructions "can" and "cannot" are not substitutes for "may" and "need not".

- will** indicates that something is certain or expected to happen as a result of action taken by an agency the behaviour of which is outside the scope of the present document
- will not** indicates that something is certain or expected not to happen as a result of action taken by an agency the behaviour of which is outside the scope of the present document
- might** indicates a likelihood that something will happen as a result of action taken by some agency the behaviour of which is outside the scope of the present document

might not indicates a likelihood that something will not happen as a result of action taken by some agency the behaviour of which is outside the scope of the present document

In addition:

is (or any other verb in the indicative mood) indicates a statement of fact

is not (or any other negative verb in the indicative mood) indicates a statement of fact

The constructions "is" and "is not" do not indicate requirements.

1 Scope

The present document contains the findings of the Study on 5G NR User Equipment (UE) application layer data throughput performance and the proposed test cases.

2 References

The following documents contain provisions which, through reference in this text, constitute provisions of the present document.

- References are either specific (identified by date of publication, edition number, version number, etc.) or non-specific.
- For a specific reference, subsequent revisions do not apply.
- For a non-specific reference, the latest version applies. In the case of a reference to a 3GPP document (including a GSM document), a non-specific reference implicitly refers to the latest version of that document *in the same Release as the present document*.

- [1] 3GPP TR 21.905: "Vocabulary for 3GPP Specifications".
- [2] 3GPP TS 38.101-1: "NR; User Equipment (UE) radio transmission and reception; Part 1: Range 1 Standalone".
- [3] 3GPP TS 38.521-4: "NR; User Equipment (UE) conformance specification; Radio transmission and reception; Part 4: Performance requirements".
- [4] 3GPP TS 38.101-4: "NR; User Equipment (UE) radio transmission and reception; Part 4: Performance requirements".
- [5] 3GPP TS 36.321: "Evolved Universal Terrestrial Radio Access (E-UTRA); Medium Access Control (MAC) protocol specification"
- [6] 3GPP TS 36.322: "Evolved Universal Terrestrial Radio Access (E-UTRA); Radio Link Control (RLC) protocol specification"
- [7] 3GPP TS 36.323: "Evolved Universal Terrestrial Radio Access (E-UTRA); Packet Data Convergence Protocol (PDCP) specification"
- [8] 3GPP TS 38.323: "NR; Packet Data Convergence Protocol (PDCP) specification"
- [9] 3GPP TS 38.523: "5GS; User Equipment (UE) conformance specification; Part 1: Protocol"
- [10] 3GPP TS 38.321: "NR; Medium Access Control (MAC) protocol specification"
- [11] 3GPP TS 38.322: "NR; Radio Link Control (RLC) protocol specification"
- [12] RFC 768
- [13] RFC 791
- [14] RFC 793
- [15] RFC 2460
- [16] RFC 8200

3 Definitions of terms, symbols and abbreviations

3.1 Terms

For the purposes of the present document, the terms given in TR 21.905 [1] and the following apply. A term defined in the present document takes precedence over the definition of the same term, if any, in TR 21.905 [1].

3.2 Symbols

Void.

3.3 Abbreviations

For the purposes of the present document, the abbreviations given in TR 21.905 [1] and the following apply. An abbreviation defined in the present document takes precedence over the definition of the same abbreviation, if any, in TR 21.905 [1].

4 General

4.1 Background

The newly-deployed 5G radio access technologies are providing a very large increase in data transmission capacity in mobile networks. This is being matched and even exceeded by a corresponding increase in the demand for data from users of the latest data-hungry devices and applications.

It is therefore essential that data devices achieve high efficiency when using data services and do not unduly load the network regardless of the maximum data rate that they are capable of achieving.

There is an interest to add 5G NR UE Application-Layer Data Throughput Measurements under various simulated network conditions to their Performance Items area of activity. As a result RAN5 recommending and produce the test procedures.

4.2 Study Item Objective

The technical objectives of this study item are:

Fixed reference measurement channels:

- a) Use existing fixed reference measurement channels scenarios already defined in TS 38.101-4 [4] and TS 38.521-4 [3] test specifications to develop test procedures to measure 5G NR UE data throughput performance at the application-layer. Adaptation of existing test cases from the TS 38.521-4 [3] specification will be part of the study with goal to determine best test points candidates.

Variable reference measurement channels:

- b) analysis of suitable link adaptation scenarios and development of corresponding 5G NR application layer throughout test procedures An analysis of upper layer protocols and parameters impacting application layer throughout measurements will also be provided.

NOTE 1: There is significant industry interest in performing application layer throughput measurements with variable reference measurement channels (link adaptation) as this represents a scenario closer to real world deployments.

The Rel-11 SI "Study on UE Application Layer Data Throughput" (FS_UE_App_Data_Perf) captured results for UMTS and LTE in a Technical Report TR 37.901. For the SI " Study on 5G NR User Equipment (UE) application layer

data throughput performance" that is proposed here it is intended to create a new Technical Report for which the following structure is proposed:

- Definition of 5G NR Application Layer Data Throughput Performance
- List of parameters to be measured:
 - Application Layer Throughput (Downlink and Uplink)
- Test configuration and upper layer parameters
- Transport Layer protocol used for data transfer
- Application Layer protocol used for data transfer
- Test environment (signal levels, fading profiles, fixed and link adaptation based scheduling, SA/NSA, FR1/FR2, etc.):
- Data transfer scenarios (TCP/UDP, DL/UL/Bidirectional)
- Minimum Test Time and Iterations (align with LTE)
- Test Procedures for 5G NR UE Application layer throughput performance

The test procedures developed will measure the achieved average application-layer data rates (e.g. using TCP or UDP) of the UE standalone or/and in combination with a laptop under simulated realistic network scheduling and radio conditions in a repeatable lab-based environment (i.e. using lab-based simulators and other necessary equipment).

NOTE 2: The point of measurement on the UE side will be either in a connected PC for terminals that support tethered mode only, or inside the UE in case of a terminal that does not support tethered mode (and supports embedded mode), or in both places for UEs that support both modes.

The test procedures will be developed in a flexible manner to accommodate various test conditions. The exact simulated network scheduling and down link radio conditions to be used will be determined during the study. It is envisaged that in addition to some measurements under "ideal conditions", an initial set of suitable scheduling/radio conditions to be used by the test systems, will be defined to simulate typical network conditions. Additional optional conditions may be developed later as and when required.

Other issues that the Study Item may investigate include:

- The definition of a reliable and repeatable test environment to ensure the best possible repeatability of the results. This could include the definition of a reference laptop configuration, applications in the UE or/and the Laptop that would measure the throughput, etc.
- The impact from the lower layers data throughput on the application-layer data throughput, especially when variable radio conditions are applied.

5 Study on 5G NR UE Application Layer Data Throughput Performance

5.1 Definition of Application Layer Data Throughput Performance

5.1.1 Definition of End Points

The test procedures defined will measure the throughput of data end to end from a server to the terminating end on the user side.

The termination on the user side will be:

- A. Inside the terminal in case of a handset that can install an embedded client application. This is considered the default mode of testing as it provides an accurate measure of user experience.
- B. Alternatively, in a connected PC in case of a handset or data module that does not support embedded mode (lacks UI, no embedded application installation possible, etc.).

For tethered connections, the UE is tethered to a laptop using the appropriate UE to PC interface Modem or Network Interface Connection (NIC) drivers as recommended by the UE manufacturer for the intended use by the customer/user. In most cases, a laptop with an embedded modem is considered to be a tethered data configuration as opposed to an embedded data configuration due to the UE to PC interface. It is noted that the physical layer capabilities of the UE to PC Interface Connection can limit the UE Application Layer Data Throughput performance. Care should be taken to ensure that the physical layer capabilities of the UE to PC Interface Connection do not affect the performance results.

For non-tethered or embedded connections as in the case of embedded applications or applications running on the UE itself, the end points are the application running on the UE and a corresponding Data Server that is adjacent to the simulated lab-based Core Network and is the default mode of connection for devices that support this mode.

For tethered connections, the end points are the application running on the PC connected to the UE and a corresponding Data Server that is adjacent to the simulated lab-based Core Network. In this case, the PC drivers (typically USB) will also play a role in the UE Application Layer Data Throughput performance.

5.2 Parameters for Measurement

5.2.1 Throughput

The 5G NR UE Application Layer Data Throughput as defined in clause 5.1.1 shall be a parameter for measurement. The parameter would apply for any chosen application. The throughput can be measured in each direction (downlink and uplink).

5.3 Test Configurations

5.3.1 5G NR UE Application Layer Data Throughput Test Equipment

The test equipment utilized for 5G NR UE Application Layer Data Throughput shall consist of the following items.

- Data client test application(s) for the UE for embedded mode operation, which shall be default mode for devices supporting this mode.
- For tethered mode operation, Laptop/PC and appropriate UE to PC interface Modem or Network Interface Connection (NIC) drivers and any associated cabling as recommended by the UE manufacturer for the intended use by the customer/user.
- Data client test application for the PC for tethered mode operation.
- System Simulator(s) suitable for the 5G NR radio technology used for testing with necessary IP connectivity.
- Application Servers.
- Faders and AWGN Sources capable of supporting the radio environments defined.

5.3.2 UE Application Layer Data Throughput Connection Diagrams

5.3.2.1 UE Application Layer Data Throughput Connection Diagram for Tethered

The UE Application Layer Data Throughput connection diagram for tethered operation is shown in Figure C.1.

5.3.2.2 UE Application Layer Data Throughput Connection Diagram for Embedded

The UE Application Layer Data Throughput connection diagram for embedded operation is shown in Figure C.2.

5.3.3 RF Connection Diagrams for UE Application Layer Data Throughput

The RF connections between the SS and the UE shall be in compliance with the associated RF connection diagrams specified in the test procedure clauses in Annex A. As the RF connection diagrams vary based on device type and UE category, it is preferable to reference appropriate RF connection diagrams for similar test configurations in the core test specifications. The RF connection diagrams are to be based on the representative RF connection diagrams referenced in 38.521-4 [3].

5.3.4 UE Specific Items

There are no UE specific items identified at this time that are required to support the UE Application Layer Data Throughput testing herein. This item is FFS.

5.4 Transport and Application Layer Protocols

5.4.1 Transport Layer Protocol

For the transport layer protocol, TCP and UDP are considered. It is proposed to test with both TCP and UDP as measurements utilizing each transport protocol are relevant.

The following items highlight the need for TCP transport.

- Most of the applications that need reliable data transfers use TCP as transport layer.
- The throughput is sensitive to the end-to-end delay.
- Good for testing FTP/HTTP in bi-directional tests in asymmetric data rate links because the downlink speeds are limited by uplink speeds. For FTP/HTTP data transfers in one direction, the TCP ACKs are transmitted in the other direction, therefore delay in receiving TCP ACK in one direction negatively impacts FTP/HTTP throughput in the other direction.

The following items highlight the need for UDP transport.

- The performance of UDP based data transfer, unlike TCP based transfer, is Operating System agnostic
- Real-Time Transport Protocols used by most of Multi Media Applications are based on UDP protocol.
- UDP Data Transfer in one direction (uplink/downlink) is not dependent on the other direction characteristics, unlike with TCP.

5.4.2 Application Layer Protocol

The following items have been considered for appropriate application layer protocols that utilize TCP as a transport protocol.

- FTP
- TFTP
- SFTP
- HTTP
- VoIP (RTP-based)

To reduce the amount of testing, it is proposed to use [FTP or raw TCP data transfer]. FTP (File Transfer Protocol) runs on top of TCP/IP and is frequently used in applications where download/upload performance would be noticeable to the end user.

The following list identifies the reasons not to duplicate testing across the other application layer protocols.

- SFTP and HTTP both use TCP as a transport protocol. So it is redundant to use HTTP/SFTP protocols to test data throughput when FTP protocol is used.
- For test purposes, HTTP is typically used to benchmark the browser's rendering capabilities as a functional test. Download performance in terms of relative throughput is not as noticeable to the end user as it would be for file downloads.
- SFTP is process intensive and used to exercise the security engine within the UE.
- TFTP is typically used in embedded devices to update the firmware in a reliable way using a low footprint stack to avoid using the full TCP stack. TFTP is a request-response protocol and is not a candidate for performance analysis.
- VoIP (RTP-based) applications are diverse in nature and application compatibility is an issue for a standard set of UE Application Layer Data Throughput Performance test procedures.

For UDP, it is proposed to use raw data transfer as opposed to defining a streaming protocol to simplify the UDP transfer application requirements.

5.4.2.1 TCP Settings

It is recommended that the TCP client/server used for testing meet the following requirements:

- The TCP send/receive buffer sizes at the server should be set to values sufficiently large to ensure they do not limit the maximum throughput achievable at the UE
- The tx queue length should be set to a value sufficiently large value to ensure flow control between the network interface (ppp) and TCP is not triggered

For embedded testing, which is considered the default mode, the embedded client will reside in the UE under test. This will require an application to be installed on the UE. It is recommended that this application meet the following requirements:

- The embedded application should allow the user to transfer files of formats supported by the UE, in binary mode, both in the Downlink and the Uplink.
- The embedded application should provide the means to compute the throughput T as defined in clause 5.1.1 at the end of each file transfer.
- The embedded application should provide an interface allowing automation of testing. If an interface for automation of testing is implemented, it is recommended to use the embedded data client automation recommendations in Annex F.
- The embedded application should not implement hidden optimizations that might impact the throughput.

It is recommended that the TCP data application used on the tethered PC for tethered testing (when embedded cannot be performed) meet the following requirements:

- The tethered TCP application should allow the user to transfer files of any format supported by the tethered PC, in binary mode, in both the Downlink and the Uplink
- The tethered TCP application should provide the means to compute the throughput T as defined in subclause 5.1.1 at the end of each file transfer
- The tethered TCP application should provide an interface allowing automation of testing
- The tethered TCP application should not implement hidden optimizations that might impact the throughput

An example of a TCP raw data generating application meeting these requirements is the iperf. This example is cited for information only and does not in any way preclude the use of other applications meeting the recommended requirements.

The following settings are to be used.

- The TCPWindowSize is derived based on the bandwidth-delay product (BDP) for the particular radio access bearer used in the test. Refer to clause 5.4.2.1.1 for guidance concerning the TCP advertised receiver window size setting.
- The TCPWindowSize is adjusted to near even-multiple of TCP MTU. The Windows Scaling is enabled for all FTP transfers.
- The socket buffer sizes are set to even-multiples of TCP MTU in use and set to values equal or greater than the BDP.
- The TCP MTU size is set to a value comprised between 1280 and 1500 bytes as recommended by the manufacturer.
- Either IPv4 or IPv6 can be used, but only results obtained with the same IP address type can be compared, since the IP address type will affect the measured throughput.

5.4.2.1.1 TCP advertised receiver window size setting

In order to achieve maximum throughput during FTP testing, the TCP advertised receiver window size must be equal to or greater than the BDP (Bandwidth Delay Product), which can be expressed as follows:

$$\text{BDP} = \text{TCP data rate} * \text{RTT}$$

Where:

TCP data rate is the portion of the radio bearer used to send TCP data

RTT is the unloaded Round Trip Time between TCP end-points (FTP server and tethered laptop/embedded FTP app) as seen by the TCP sender.

Note that the TCP data rate and the RTT may be different for different test procedures.

5.4.2.2 UDP Settings

It is recommended that the UDP server used for testing meet the following requirements:

- UDP blast duration shall be selected to meet the minimum test times using a sufficient rate to prevent physical layer DTX based upon the UE Category.

For embedded testing, which is the default mode, the UDP client will reside in the UE under test. This will require an UDP application to be installed on the UE. It is recommended that this application meet the following requirements:

- The embedded UDP application should allow the user to transfer files of formats supported by the UE, in binary mode, both in the Downlink and the Uplink.
- The embedded UDP application should provide the means to compute the throughput T as defined in subclause 5.1.1.
- The embedded UDP application should provide an interface allowing automation of testing. If an interface for automation of testing is implemented, it is recommended to use the embedded data client automation recommendations in Annex E.
- The embedded UDP application should not implement hidden optimizations that might impact the throughput.

It is recommended that the UDP application used on the tethered PC for tethered testing (when embedded testing cannot be performed) meet the following requirements:

- The tethered UDP application should allow the user to transfer files of any format supported by the tethered PC, in binary mode, in both the Downlink and the Uplink.
- The tethered UDP application should provide the means to compute the throughput T as defined in subclause 5.1.1.
- The tethered UDP application should provide an interface allowing automation of testing.

- The tethered UDP application should not implement hidden optimizations that might impact the throughput.

The following settings are to be used.

- The UDP MTU size is set to a value comprised between 1280 and 1500 bytes as recommended by the manufacturer.
- The UDP transfers are always carried out in Binary mode.
- The contents of the files to be transferred over UDP are chosen in such a way that they are statistically random, with least compressibility.
- No application level compression protocols are used to compress the UDP files.
- Either IPv4 or IPv6 can be used, but only results obtained with the same IP address type can be compared, since the IP address type will affect the measured throughput.

5.4.3 Upper Layer impact on throughput measurements

5.4.3.1 Overview

The NG user plane interface (NG-U) is defined between the NG-RAN node and the 5G User Plane Function (UPF). The user plane protocol stack of the NG interface is shown on Figure 5.4.3.1-1. The transport network layer is built on IP transport and GTP-U is used on top of UDP/IP to carry the user plane PDUs between the NG-RAN node and the UPF.

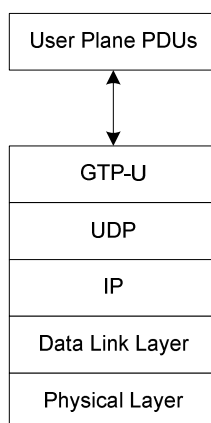

Figure 5.4.3.1-1: NG-U Protocol Stack

NG-U provides non-guaranteed delivery of user plane PDUs between the NG-RAN node and the UPF.

To understand the transport layer mechanisms better (as they are the key component of end to end data throughput testing), it needs to be noted that both gNB and ng-eNB are connected to 5GC over NG interface.

The transport layer for data streams over NG is an IP based Transport. The following figure shows the transport protocol stacks over NG

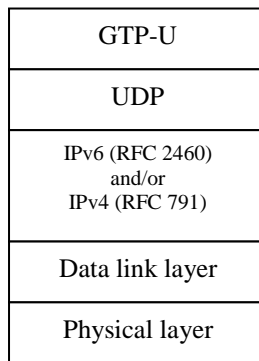

Figure 5.4.3.1-2: Transport network layer for data streams over NG

The GTP-U (TS 29.281 [3]) protocol over UDP over IP shall be supported as the transport for data streams on the NG interface. The data link layer is as specified in clause 4.

The transport bearer is identified by the GTP-U TEID (TS 29.281 [3]) and the IP address (source TEID, destination TEID, source IP address, destination IP address).

For the purpose of understanding transport layer throughput aspect, it can be focused on the below block diagram which depicts the key layer within which data overhead has to be accounted when estimating expected end to end throughput.

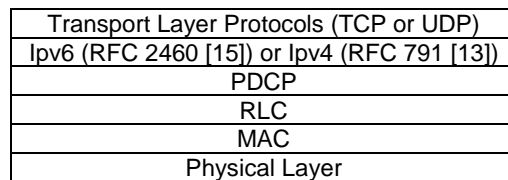

Figure 5.4.3.1-3: 5G NR Data Plane Stack

5.4.3.2 TCP/UDP Layer

Starting with the transport layer, it shall be assumed 1500 octets of MTU size at IP layer throughout this discussion paper (as described in clause 2.3).

TCP header size is 24 octets, according to RFC 793 [14].

UDP header size is 8 octets, according to RFC 768 [12].

Worst case effective TCP payload = $1460 - 24 = 1436$ octets (IPv6) and $1476 - 24 = 1452$ octets (IPv4).

Worst case effective UDP payload = $1460 - 8 = 1452$ octets (IPv6) and $1476 - 8 = 1468$ octets (IPv4)

5.4.3.3 IP Layer

Header size for IPv6 packet is 40 octets (RFC 8200 [16]) and 24 octets for IPv4 packet (RFC 791 [13]).

Typical MTU size used is 1500 octets according to RFC 2460 [15].

Therefore, the worst case Effective payload = $1500 - 40 = \mathbf{1460}$ octets for IPv6 and $1500 - 24 = \mathbf{1476}$ octets for IPv4

5.4.3.4 PDCP Layer

Maximum supported size of PDCP SDU is 9000 octets, according to TS 38.323 [8] .0 clause 4.3.1

Maximum overheads due to PDCP-SN and MAC-I are 7 octets, according to TS 38.523-1 [9] clauses 6.3.2 and 6.3.4.

For a typical MTU size of 1500 octet in IP layer, and considering 7 octets of overhead, maximum allowable RLC Data field size is $1500+7 = 1507$ octets.

5.4.3.5 RLC Layer

Based on TS 38.322 [11] Clause 6.2.2, Maximum RLC PDU header size is 5 octets.

Allowable maximum MAC SDU is $1507+5 = 1512$ octets

As per TS 38.321 [10], maximum MAC header size can be up to 3 octets, making effective MAC payload size to be $1512+3 = 1515$ octets

5.4.3.6 Overhead between MAC and TCP/UDP layer

In this clause, it is calculated the cumulative overhead due to headers added at each of the layers: MAC, RLC, PDCP, IP and TCP/UDP.

For UDP, cumulative overhead between MAC and UDP is $(1516-1452)/1516 = 4.1\%$ for IPv6

and $(1516-1468)/1516 = 3.1\%$ for IPv4

For TCP, cumulative overhead between MAC and TCP is $(1516-1436)/1516 = 5.5\%$ for IPv6

And $(1516-1452)/1516 = 4.4\%$ for IPv4

5.4.3.7 Overhead for LTE

For LTE, maximum MAC and RLC header sizes are comparable to NR, according to TS 36.321 [5] and TS 36.322 [6] respectively.

Based on TS 36.323 [7], DRB PDCP headers can be up to 3 octets, this is lower than NR PDCP overhead as discussed in clause 2.5.

Hence, the overhead calculated in clause 2.7 can be proposed for LTE.

5.4.3.8 SA, NSA and NSA split-bearer

Overhead calculated in clause 2.7 is applicable for SA test mode.

For NSA Secondary Cell Group bearer and split-bearer case, similar overhead can be used based on above discussion.

5.4.4 Summary of Upper Layer Parameters and Overhead from MAC to Transport Layer

For a typical use case of 1500 octet Maximum Transmission Unit at IP layer, the header sizes for Protocol layers above MAC layer is shown in Table 5.4.4-1.

Table 5.4.4-1: Upper Layer Header Sizes

Protocol Layer	Header Size (Octet)
TCP	24
UDP	8
IP	40 for IPv6 24 for IPv4
SDAP	1 for SA
PDCP	7
RLC	5
MAC	3

Based on Table 5.4.4-1, it is derived overhead between MAC and TCP/UDP layer as shown in Table 5.4.4-2 and Table 5.4.4-3, for IPv6 and IPv4 respectively.

Table 5.4.4-2: Overhead between TCP/UDP layer and MAC layer for IPv6

Protocol Layer	MAC PDU Size (Octet)	Upper Layer PDU size [TCP/UDP] (Octet)	%Overhead = $[1-(\text{MAC PDU Size}/\text{Upper Layer PDU size})] \times 100 \%$
TCP	1516	1436	5.5
UDP	1516	1452	4.1

Table 5.4.4-3: Overhead between TCP/UDP layer and MAC layer for IPv4

Protocol Layer	MAC PDU Size (Octet)	Upper Layer PDU size [TCP/UDP] (Octet)	%Overhead = $[1-(\text{MAC PDU Size}/\text{Upper Layer PDU size})] \times 100 \%$
TCP	1516	1452	4.4
UDP	1516	1468	3.1

In summary:

- For IPv4 TCP Application Layer Throughput tests, the measured throughput at upper layer is around 5 % reduced from physical layer throughput.
- For IPv4 UDP Application Layer Throughput tests, the measured throughput at upper layer is around 3 % reduced from physical layer throughput.
- For IPv6 TCP Application Layer Throughput tests, the measured throughput at upper layer is around 6 % reduced from physical layer throughput.
- For IPv6 UDP Application Layer Throughput tests, the measured throughput at upper layer is around 4 % reduced from physical layer throughput.

5.5 Test Environment

5.5.1 Conducted Testing for 5G NR FR1

5.5.1.1 Signal Levels

The signal levels chosen for test should either be representative of field conditions or appropriate for the test purpose of the particular test procedure defined.

In order to optimize test time and to focus on the appropriate set of signal levels for test, it is proposed to leverage the signal levels for test associated with the associated performance test cases in TS 38.521-4 [3] or to limit the number of signal levels for the majority of the downlink performance tests to a representative range. For test cases that would require specific geometries to be set, this approach is reasonable and allows as much re-use of existing test setups as possible.

However, one aspect of a receiver's performance that is not typically addressed in the conformance testing is the ability of the receiver to perform well across a range of signal levels in a relatively low-noise environment where the UE noise floor may be the dominant factor in determining SNR. The end user would expect the 5G NR UE Application Layer Data Throughput to increase as the signal level is increased in relation to the UE noise floor or to achieve relatively consistent 5G NR UE Application Layer Data Throughput if located in a sufficient signal strength area such that the throughput has reached a maximum.

5.5.1.2 Fading Profiles

It is proposed to consider the following fading profiles to maintain consistency with 3GPP defined fading profiles in TS 38.521-4 [3] that have been developed to assess a UE's capability of performing in various multi-path environments. Also, a static propagation condition should be considered for any uplink testing and any downlink performance testing where the test purpose does not specifically require fading (e.g. maximum throughput testing, stress testing where the focus is on processor utilization aspects, etc.).

For 5G NR, the following defined 3GPP profiles have been considered depending on the particular test procedure.

- TDLA30
- TDLC300
- TDLB100

5.5.2 Radiated Testing for 5G NR FR2

5.6 Data Transfer Scenarios

5.6.1 TCP Transfers

It is proposed to execute the following data transfer scenarios for TCP.

- Downlink Only
- Uplink Only
- Bi-Directional (FFS on whether concurrent or alternating or both procedures need to be defined)

5.6.2 UDP Transfers

It is proposed to execute the following data transfer scenarios for UDP.

- Downlink Only
- Uplink Only
- Bi-Directional (FFS on whether concurrent or alternating or both procedures need to be defined)

5.7 Statistical Analysis

5.7.1 Overview of Layer 1 throughput

When L1 throughput is measured during receiver and performance tests, the fundamental goal is to compare the measured throughput around the expected throughput for a specific reference measurement channel. Since the parameters in receiver and performance tests are better known, it is possible to perform this analysis.

In L1 throughput tests, there is a fixed reference channel so the number of payload bits per block is constant. In a fixed reference channel, it can be therefore can determine the maximum throughput.

With this knowledge, it is known that if the throughput limit at layer 1 is defined as 70 % of the maximum throughput, a UE that just meets this limit receives 70 % correct blocks of constant TBS (returns an ACK) and 30 % corrupted or missed blocks (returns NACK or statDTX). Nevertheless, the error events (corrupted or missed blocks) are mainly independent.

These facts allow one to derive statistics which tells us the variance of the true throughput around the measured one. These statistics are used to determine the minimum number of samples for a given confidence level for the pass/fail decision.

Another aspect that impacts minimum test time is fading. The minimum test time due to fading is long for slow speed propagation profiles and short for high speed ones. The longer minimum test time of the two aspects (statistical or fading) applies.

A quick analysis of all the FMCS test points that are proposed in the Annex, to be used for 5G NR application layer throughput testing, gives a possible way forward for determining a reasonable value for the minimum test time. All these points are extracted from Annex G.3.5 in TS 38.521-4 [3] and listed below in Table 4.1-1.

Table 5.7.1-1: Minimum Test time for the Selected FMCS test points

Test Group	TDD UL-DL pattern	Reference Channel	Demodulation scenario (doppler speed)	Minimum number of active subframes (MNAS)	Minimum Number of Subframes (MNS) after rounding up to nearest thousand $MNS = 1000 * \left\lceil \frac{MNAS}{1000} \right\rceil$	Minimum Test Time
1	NA	R.PDSCH.1-1.1 FDD	400 Hz	10000 (Note 1)	11000	11s
2	NA	R.PDSCH.1-2.1 FDD	100 Hz	20000 (Note 1)	22000	22s
3	NA	R.PDSCH.1-2.2 FDD, R.PDSCH.1-2.3 FDD, R.PDSCH.1-2.4 FDD, R.PDSCH.1-3.1 FDD, R.PDSCH.1-4.1 FDD,	10 Hz	75000 (Note 1)	79000	79s
4	FR1.30-1A	R.PDSCH.2-1.1 TDD	400 Hz	10000 (Note 1)	13000	12s
5	FR1.30-1	R.PDSCH.2-2.1 TDD,	100 Hz	20000 (Note 1)	26000	26s
6	FR1.30-1	R.PDSCH.2-4.1 TDD, R.PDSCH.2-3.1 TDD, R.PDSCH.2-2.2 TDD R.PDSCH.2-2.3 TDD R.PDSCH.2-2.4 TDD	10 Hz	75000 (Note 1)	97000	97s

NOTE 1: MNAS determined by simulations in TS 38.101-4 [4].
NOTE 2: For cases where MNS is not determined by simulations, use same MNAS as the similar case simulated (same doppler speed).

5.7.2 Overview of Application Layer throughput

During the application layer data throughput, it can be also recorded ACK, NACK and stat DTX in order to calculate the L1 payload bit throughput, although this is not the main target of the test procedure. The measured throughput and its comparison to an expected throughput value can be evaluated. However, the parameters for this measurement are not as controlled as in the case of layer 1 throughput.

In general, the application layer throughput is impacted by variations at the physical layer. This is the reason for a variety of test points being picked across different physical layer conditions (doppler, signal-to-noise ratio, antenna configurations, etc.).

For fixed reference channel testing, the UE is compared against a predefined limit at the physical layer. Therefore, statistics can be derived to determine the minimum number of samples for a given confidence level for the pass/fail decision. While the application layer data throughput is of a statistical nature, in case of fixed reference channel testing, it is possible to set a lower bound for the achievable throughput by computing the overhead due to upper layers as done in [3].

However, it is clear that to determine the test times, the key factor is the physical layer parameters specifically doppler/fading that provide the lower bound for test times.

5.7.3 Test Time for Application Layer Throughput procedures

Based on the overview provided in clauses 5.7.1 and 5.7.2 along with the observations recoded in Table 5.7.1-1 it can be categorized the required test time as below:

- For static channel tests, since 3G and 4G timeframe, 60 seconds has been chosen to be a reasonable test time.
- In Table 5.7.1-1, for test groups 1,2,4 and 5 a common value of 30 seconds seems to be a reasonable test time. However considering these are high doppler conditions and the impact of lower layer PHY mechanisms on upper layer throughput, it is advisable to not use the "last escape from corridor" depicted in Figure G.1.5 but give some additional allowance and use a 60 second test time.
- In Table 5.7.1-1, for test groups 3 and 6, a value of 90 seconds would serve as reasonable test time.
- The test time used above is significantly above the "minimum test time" governed by physical layer parameters. Therefore the number of iterations can be chosen to be 3.
- For stress tests, iteration number and time is FFS.

Table 5.7.3-1: Test Times for 5G NR App Tput

Channel Profile	Test Time per iteration (seconds)
Static	60s
100 Hz/400 Hz	60s
10 Hz	90s

5.8 Impact of Modem Performance in Application Layer Throughput

Modem performance has substantial impact on application layer throughput, particularly when the tests are performed with AWGN with fading scenarios. The section 5.8.1 shows how a modem performs against different channel condition in a commercial conformance system. The subsequent article 5.8.2 discusses about modem performance in application layer throughput tests and provides reasoning why modem performance impacts application layer throughput tests.

5.8.1 Modem Performance in current TS 38.521-4 conformance tests

TS 38.521-4 includes many throughput test cases for covering variety of UE categories. Set of these test cases covers following varying parameters:

- AWGN level
- Fading types
- Doppler/UE speed
- Power level
- Modulation order

These test cases are in process of being verified and validated on commercially available conformance test platforms. For conformance purposes, it has a pass/fail criterion, but test platform also measures throughput, ACK/NAK percentages for each test points.

Editor's note: data point collected on commercial system FFS

5.8.2 Modem Performance in Application Layer Data Throughput Tests

Application layer performance measuring the application layer throughput exposes possible UE bugs in the upper layer which may not be found in the L1. There are multiple dependencies in the upper layer protocols/algorithm which can impact user perception of data throughput. Which is why testing application layer throughput is important and adds value to gauge user experience.

The TCP was originally designed for wired network, where packet drop usually occurs due to congestion, does not tailor to the fact that packet drop in wireless can happen due to reasons other than congestion, so TCP algorithms in the like of slow-start and, first retransmit may not address wireless network challenges. Apart from TCP algorithms, USB driver, IP configuration, embedded application, router-ip tunnelling mechanism can also contribute to throughput loss.

Network vendor may also have their own algorithm to optimize the BLER target in their live network and UE has to account for these different algorithms while maintaining user perceived throughput.

Editor's note: Empirical data and analysis FFS

5.9 Test System Uncertainty and Test Tolerance

Editor's note: Some introductory and informational text is added in line with TR 37.901. No analysis or impact on any test case or procedure is included at this stage.

5.9.1 Test System Uncertainty and Test Tolerance for FR1 testing

5.9.1.1 Recommended Uncertainty of Test System

The test system should fulfil the 3GPP test system uncertainty values for 5G NR throughput tests specified in Annex F of TS 38.521-4 [3]. If a test system cannot fulfil the 3GPP test system uncertainty requirements, then the test system vendor shall declare its test system uncertainty values.

5.9.1.2 Test Tolerances

Since there are no absolute minimum requirements nor PASS/FAIL requirements in tests specified in the present TR the test tolerances are not defined which should be understood as the applicable test tolerance being set to zero in all tests. If PASS/FAIL requirements are recommended, appropriate analysis of test tolerance shall be considered.

5.9.1.3 Impact of Test System Uncertainty on Test Results

Test system uncertainties play a big role in application layer throughput results. The tighter the uncertainty requirements are the more re-producible and comparable the results are.

In TS 38.521-4 [3] applicable test system uncertainty has been specified for each test case. Test System Uncertainty is a measure how accurately tester can setup the certain parameter/signal level to the specified level. In 5G NR throughput tests the most meaningful test system uncertainties are:

- TBD

These specified test system uncertainties are very tight requirements for test systems. Typically the specified uncertainty values are the best that test system vendors can achieve when their test systems are fully calibrated. Full calibration means that each individual device, signal route and cable has to be calibrated. Hence the calibration costs take quite a big share of total costs of 3GPP compliant test systems.

There are several reasons why 3GPP has specified very tight requirements for test system uncertainties. Some reasons being highlighted below:

- There is strong industry requirement that test systems should not PASS a bad UE.
- Loose test system uncertainties result in big test tolerances. The smaller the test tolerances are the smaller is the probability that a test system passes a bad UE. (Since minimum requirements are relaxed by the amount of test tolerances there is a small chance that a bad UE passes the test thanks to relaxed test requirements but UE would fail if test tolerances were zero)

- The tests should be as reproducible as possible:
 - Without accurate test system calibration the test result may change from day to day / from frequency to frequency.
- The test results should be as comparable as possible from device to device and from test system vendor to test system vendor:
 - All test systems should give a same PASS/FAIL verdict for one UE, and also each test system should give roughly the same actual test results.

5.9.2 Test System Uncertainty and Test Tolerance for FR2 testing

6 Conclusions

Editor's Note: - Conclusion to be closed once all the TBD/FFS articles are addressed in the study item

The UE application layer Data throughput study item was initiated by RAN5 to include UE application layer Data throughput under various simulated network conditions. The following aspects were included as part of this study,

Definition of UE application later data throughput performance

Parameters of measurements

Test configurations

Transport/application layer protocols

Test environment

Overhead analysis

Statistical analysis

Impact of modem performance in application layer throughput

Test uncertainty and test tolerance

Hence, the following items have been identified at the conclusion of the study item

Definition of UE Application Layer Data Throughput Performance and identification of the test end points

<Additional points FFS?

This technical report includes a set of recommended test procedures for UE Application Layer Data Throughput that is in-line with the study item objectives identified in clause 4.

The test procedures are contained in Annex A with the specific test conditions and environments covered in Annex B. The test procedures to provide a measure of UE data performance at the application is yet to be concluded.

Annex A: Test Procedures

A.1 Purpose of annex

This annex specifies the test cases for 5G NR UE Application Layer Data Throughput Performance. The test cases are the result of the study item and are the recommended test cases to be used when evaluating UE Application Layer Data Throughput Performance. The use of "shall" in the test cases listed herein is only used to indicate that the test case purpose, procedure, and/or result may not be as expected if the specified "shall" or "must" item is not used or followed. As the Technical Report is informative in nature, the use of "shall" or "must" in the test cases is not meant to imply a specific requirement. Their use is meant to indicate instances where the test objectives of the recommended test cases may not be achieved.

A.1.1 General

The following test procedures will evaluate the UE Application Layer Data Throughput Performance for 5G NR UE.

The UE should be tested in any data configuration that it supports with embedded being the default mode and tethered mode used if embedded is not supported.

A laptop with an embedded modem is considered to be a tethered data configuration while an embedded data configuration due to the UE to PC interface. Refer to the Tethered Data connection diagram in figure C.2.1-1.

For an embedded data configuration, the UE will be the endpoint of the measurement and will have the appropriate data client test applications called out in the test procedures. Refer to the Embedded Data connection diagram in figure C.2.2-1.

For a tethered data configuration, the UE will be tethered to a laptop using the appropriate UE to PC interface Modem or Network Interface Connection (NIC) drivers as recommended by the UE manufacturer for the intended use by the customer/user. Refer to the Tethered Data connection diagram in figure C.2.1-1.

The propagation conditions and physical channel configurations are specified within the test cases in TS 38.521-4 [3] from which the test points are picked.

All throughput measurements in Annex A shall be performed according to the following general rules:

- The measured UE Application Layer Throughput, T, is defined in clause 5.1.1.
- Minimum test time is necessary for both static and multipath fading profiles to ensure stabilization of the TCP or UDP Application throughput. The following table provides the test times to be applied.

Table A.1.1-1: Data Transfer Duration Times

Channel Profile	Test Time per iteration
Static	60s
100 Hz/400 Hz	60s
10 Hz	90s

- TCP parameters and transfer duration shall be selected according to the test purpose to meet the minimum test times. Please refer to clause 5.4.2.1 for TCP setting details
- UDP parameters and transfer duration shall be selected according to the test purpose and to meet the minimum test times. Please refer to clause 5.4.2.2 for UDP setting details

The application layer data throughput performance for a UE will be determined across multiple scenarios (2Rx/4Rx, Conducted/Radiated, SA/NSA, Static/Fading Results shall be recorded for the following clauses which characterize the UE performance across a variety of application layer scenarios utilizing both FTP and UDP protocols.

- TCP Downlink Performance

- UDP Downlink Performance
- TCP Uplink Performance
- UDP Uplink Performance

IP header compression will not be used.

The integrity protection algorithm of RRC and NAS messages shall be set to one of the algorithms supported by the UE under test. The ciphering of RRC and NAS messages and user plane data will be set to [null] for UDP and [AES] for TCP to check CPU processing ability of UE.

The recorded UE throughput for the TCP and UDP Downlink and Uplink Performance test procedures shall be based upon the simple average of 3 transfers for each test condition as detailed in clause 5.7.

Unless otherwise stated, the UE output power for the tests shall be set 0 dBm with ± 2 dBm tolerance.

Either IPv4 or IPv6 can be used, but only results obtained with the same IP address type can be compared, since the IP address type will affect the measured throughput. Refer to clause 5.4.4 for details on impact of headers, to measured UDP/TCP throughput, which shall be incorporated into any measurements.

CONDUCTED TCP DOWNLINK – STATIC CHANNEL

A.2 5G NR /TCP Downlink Throughput /Conducted/Static Peak Throughput for SA and NSA

A.2.1 5G NR /TCP Downlink Throughput /Conducted/Static Channel Peak Throughput tests for SA and NSA

A.2.1.1 5G NR /TCP Downlink Throughput /Conducted/Static Channel/ SA and NSA (no Downlink Split Bearer)

A.2.1.1.1 Definition

The UE application layer downlink performance for TCP under different static environment is determined by the UE application layer TCP throughput.

A.2.1.1.2 Test Purpose

To measure the performance of the 5G NR UE while downloading TCP based data in a static channel environment.

A.2.1.1.3 Test Parameters

The common test parameters are defined in TS 38.521-4 [3] Table 5.5.1.3-1. The parameters specified in TS 38.521-4 [3] Table 5.5.1.3-2 are applicable for tests on FDD bands and parameters specified in TS 38.521-4 [3] Table 5.5.1.3-3 are applicable for tests on TDD bands. CORESET details are in TS 38.521-4 [3] Table 5.5.1.3-4 and MCS indices for indicated UE capabilities are in TS 38.521-4 [3] Table 5.5.1.3-5. The test parameter selection procedure is defined in TS 38.521-4 [3] clause 5.5.1.3.1. In addition, the following test statements from TS 38.521-4 [3] clause 5.5.1.3 apply:

- Unless otherwise stated, no user data is scheduled on slot #0, 10 and 11 within 20 ms for SCS 15 kHz.
- Unless otherwise stated, no user data is scheduled on slot #0, 20 and 21 within 20 ms for SCS 30 kHz.

For NSA case, since this test is not focused on aggregated throughput, the E-UTRA anchor is functional link and is setup via the parameters defined in Annex E.

Test point is detailed in Annex D.1-5.

Table A.2.1.1.3-1 FR1 Static Channel Test Point

TS 38.521-4 Reference	Reference channel	Bandwidth (MHz) / Subcarrier spacing (kHz)	Modulation format and code rate	TDD UL-DL pattern	Propagation condition	PHY Reference value		Comment
						Fraction of maximum throughput (%)	SNR (dB)	
5.5.1	As per tables in TS 38.521-4 [3] clause 5.5.1.3 and test parameter selection as per TS 38.521-4 [3] 5.5.1.3.1.			Static/ Clean Channel	85 %	No external noise sources are applied	Peak Throughput	

A.2.1.1.4 Test Description

A.2.1.1.4.1 Initial Conditions

Initial conditions are a set of test configurations the UE needs to be tested in and the steps for the SS to take with the UE to reach the correct measurement state. Apply the Initial conditions defined in TS 38.521-4 [3] clause 5.5.1.4.1 with the following additional steps and/or exceptions

1.1 Connect an application server to the IP output of the SS.

1.2 For an embedded configuration, ensure that the UE has an client test application available. For a tethered configuration, tether the UE to a laptop configured with FTP client software using the appropriate UE to PC interface Modem or Network Interface Connection (NIC) drivers. 5. For NSA case, the E-UTRA anchor is configured as per Annex E. Ensure the UE is in RRC_CONNECTED State. Message contents are as per TS 38.521-4 [3] Table 5.5.1.4.3-1 through Table 5.5.1.4.3-8.

A.2.1.1.4.2 Test Procedure

- SS sets the parameters of the bandwidth, MCS and DL reference channel (RMC) according to the test parameter selection procedure defined in TS 38.521-4 [3] clause 5.5.1.3.1. The SS transmits PDSCH via PDCCH DCI format 1_1 for C_RNTI to transmit the DL RMC.
- SS sends uplink scheduling information for each UL HARQ process via PDCCH DCI format 0_1 for C_RNTI to schedule the UL RMC over PUSCH according to parameters set during initial conditions . The purpose of this scheduling is to accommodate for TCP UL ACK/NACK feedback transmissions.
- Using the data client, begin TCP downlink data transfer from the application server. Wait for 15 seconds and then start recording the TCP throughput result. (This is iteration 1) Continue data transfer for the test duration outlined in Table A.1-1.
- Repeat step 3 for 3 iterations within the same call as the first iteration. Wait for at least 5 seconds between each iteration of the data transfer.
- Calculate and record the average application layer data throughput across three iterations. Additionally, count and record the overall number of ACK and NACK/DTX on the PUSCH/PUCCH during the test interval. Record the IP address type (IPv4 or IPv6) used during the TCP data transfers.
- Using the values in Table 5.4.4-2 (for IPv6) and Table 5.4.4-3 (for IPv4), determine the reduction from PHY reference fractional throughput value listed in Table A.2.1.1.3-1 to obtain reference Application Layer Throughput value.

A.2.1.2 5G NR /TCP Downlink Throughput /Conducted/Static Channel/NSA (Downlink Split Bearer)

A.2.1.2.1 Definition

The UE application layer downlink performance for TCP under different static environment is determined by the UE application layer TCP throughput.

A.2.1.2.2 Test Purpose

To measure the performance of the 5G NR UE while downloading TCP based data in a static channel environment.

A.2.1.2.3 Test Parameters

The common test parameters are defined in TS 38.521-4 [3] Table 9.4B.1.1.3-1. The parameters specified in TS 38.521-4 [3] Table 9.4B.1.1.3-2 are applicable for tests on FDD bands and parameters specified in TS 38.521-4 [3] Table 9.4B.1.1.3-3 are applicable for tests on TDD bands. CORESET details are in TS 38.521-4 [3] Table 9.4B.1.1.3-4 and MCS indices for indicated UE capabilities are in TS 38.521-4 [3] Table 9.4B.1.1.3-5. The test parameter selection procedure is defined in TS 38.521-4 [3] clause 9.4B.1.1.3.1. In addition, the following test statements from TS 38.521-4 [3] clause 9.4B.1.1.3 apply:

- Unless otherwise stated, no user data is scheduled on slot #0, 10 and 11 within 20 ms for SCS 15 kHz for the NR cell.
- Unless otherwise stated, no user data is scheduled on slot #0, 20 and 21 within 20 ms for SCS 30 kHz for the NR cell.

For NSA case, the focus in this test is to measure aggregated throughput therefore data rate over the E-UTRA carrier is also included in the measurements. The aggregated data rate over E-UTRA and NR carriers is carried out once the aforementioned test parameter selection in TS 38.521-4 [3] clause 9.4B.1.1.3.1 is completed.

Test point is detailed in Annex D.1-5.

Table A.2.1.2.3-1 FR1 Static Channel Test Point

TS 38.521-4 Reference	Reference channel	Bandwidth (MHz) / Subcarrier spacing (kHz)	Modulation format and code rate	TDD UL-DL pattern	Propagation condition	PHY Reference value		Comment
						Fraction of maximum throughput (%)	SNR (dB)	
5.5.1	As per tables in TS 38.521-4 [3] clause 5.5.1.3 and test parameter selection as per TS 38.521-4 [3] 5.5.1.3.1.				Static/ Clean Channel	85 %	No external noise sources are applied	Peak Throughput

A.2.1.2.4 Test Description

A.2.1.2.4.1 Initial Conditions

Initial conditions are a set of test configurations the UE needs to be tested in and the steps for the SS to take with the UE to reach the correct measurement state. Apply the Initial conditions defined in TS 38.521-4 [3] clause 9.4B.1.1.4.1 with the following additional steps and/or exceptions:

- 1.1 Connect an application server to the IP output of the SS.
- 1.2 For an embedded configuration, ensure that the UE has an client test application available. For a tethered configuration, tether the UE to a laptop configured with FTP client software using the appropriate UE to PC interface Modem or Network Interface Connection (NIC) drivers.

5. Setup an NSA call with E-UTRA anchor initially scheduled as per Annex E.

A.2.1.2.4.2 Test Procedure

1. SS sets the parameters of the bandwidth, MCS and DL reference channel (RMC) according to the test parameter selection procedure defined in TS 38.521-4 [3] clause 5.5.1.3.1. The SS transmits PDSCH via PDCCH DCI format 1_1 for C_RNTI to transmit the DL RMC.
2. SS sends uplink scheduling information for each UL HARQ process via PDCCH DCI format 0_1 for C_RNTI to schedule the UL RMC over PUSCH according to parameters set during initial conditions. The purpose of this scheduling is to accommodate for TCP UL ACK/NACK feedback transmissions.
3. Using the data client, begin TCP downlink data transfer from the application server. Wait for 15 seconds and then start recording the TCP throughput result. (This is iteration 1) Continue data transfer for the test duration outlined in Table A.1-1.
4. Repeat step 3 for 3 iterations within the same call as the first iteration. Wait for at least 5 seconds between each iteration of the data transfer.
5. Calculate and record the average application layer data throughput across three iterations. Additionally, count and record the overall number of ACK and NACK/DTX on the PUSCH/PUCCH during the test interval. Record the IP address type (IPv4 or IPv6) used during the TCP data transfers.
6. Using the values in Table 5.4.4-2 (for IPv6) and Table 5.4.4-3 (for IPv4), determine the reduction from PHY reference fractional throughput value listed in Table A.2.1.2.3-1 to obtain reference Application Layer Throughput value.

CONDUCTED TCP DOWNLINK – FADING (FRC)

A.3 5G NR /TCP Downlink Throughput /Conducted for Fixed Reference Channel (FRC) Scenarios with Fading for SA and NSA

A.3.1 5G NR /TCP Downlink Throughput /Conducted/Fading/FRC for SA and NSA

A.3.1.1 5G NR /TCP Downlink Throughput /Conducted/Fading/FRC/2Rx for SA and NSA

A.3.1.1.1 5G NR /TCP Downlink Throughput /Conducted/Fading/2Rx/FR1 PDSCH mapping Type A performance - 2x2 MIMO for SA and NSA

A.3.1.1.1.1 Definition

The UE application layer downlink performance for TCP is determined by the UE application layer TCP throughput.

A.3.1.1.1.2 Test Purpose

To measure the performance of the 5G NR UE using fixed reference channels and under 2 receive antenna conditions while downloading TCP based data in fading channel environment. The duplex mode is FDD.

A.3.1.1.1.3 Test Parameters

The test points to be used in this test are defined in Table A.3.1.1.1.3-1. Details of these test points are available in Annex D with the test points below referenced directly from Table D.1-1.

Table A.3.1.1.1.3-1: FR1 FDD 2RX

TS 38.521-4 Reference	Test num.	Reference channel	Modulation format	Propagation condition	Correlation matrix and antenna configuration	Reference value		Comment
						Fraction of maximum throughput (%)	SNR (dB)	
5.2.2.1.1_1 2Rx FDD	1-3	R.PDSCH.1-4.1 FDD	256AM, 0.82	TDLA30-10	2x2, ULA Low	70	25.6	Large TBS
5.2.2.1.1_1 2Rx FDD	1-4	R.PDSCH.1-2.1 FDD	16QAM, 0.48	TDLC300-100	2x2, ULA Low	30	2	High BLER
5.2.2.1.1_1 2Rx FDD	1-1	R.PDSCH.1-1.1 FDD	QPSK, 0.30	TDLB100-400	2x2, ULA Low	70	0.1	High channel variation
5.2.2.1.1_1 2Rx FDD	2-1	R.PDSCH.1-3.1 FDD	64QAM, 0.51	TDLA30-10	2x2, ULA Low	70	20.4	High throughput Baseline Rx
5.2.2.1.1_2 2Rx FDD	3-1	R.PDSCH.1-2.2 FDD	16QAM, 0.48	TDLA30-10	2x2, ULA Medium	70	18.6	High throughput Enhanced Rx

Other test parameters are defined in TS 38.521-4 [3] Tables 5.2.2.1.1_1.4-1 and 5.2.2.1.1_1.4-2.

A.3.1.1.1.4 Test Description

A.3.1.1.1.4.1 Initial Conditions

Initial conditions are a set of test configurations the UE needs to be tested in and the steps for the SS to take with the UE to reach the correct measurement state. Apply the Initial conditions defined in TS 38.521-4 [3] clause 5.2.2.1.1_1.3.1 with the following additional steps and/or exceptions

1.1 Connect an application server to the IP output of the SS.

1.2 For an embedded configuration, ensure that the UE has an client test application available. For a tethered configuration, tether the UE to a laptop configured with TCP client software using the appropriate UE to PC interface Modem or Network Interface Connection (NIC) drivers. 5. For NSA case, the E-UTRA anchor is configured as per Annex E. Ensure the UE is in RRC_CONNECTED State (on NR for SA and on E-UTRA for NSA with NR PSCell added). Message contents are as per TS 38.521-4 [3] clause 5.2.2.1.1_1.3.3 and 5.2.2.1.1_1.3.3_2 and Tables 5.2.2.1.1_1.3.3_1-1 through 5.2.2.1.1_1.3.3_1-4.

A.3.1.1.1.4.2 Procedure

1. SS transmits PDSCH via PDCCH DCI format 1_1 for C_RNTI to transmit the DL RMC according to TS 38.521-4 [3] Table 5.2.2.1.1.0-2. The SS sends downlink MAC padding bits on the DL RMC.
2. Set the parameters of the Modulation format and code rate, reference channel, the propagation condition, the correlation matrix and the SNR according to TS 38.521-4 [3] Tables 5.2.2.1.1_1.4-1 and 5.2.2.1.1_1.4-2 as applicable to the test points in Table A.3.1.1.1.3-1.
3. Using the data client, begin TCP downlink data transfer from the application server. Wait for 15 seconds and then start recording the TCP throughput result. (This is iteration 1) Continue data transfer for the test duration outlined in A.1.1-1. Repeat transfer for iterations [2-3] within the same call as the first iteration.
4. Repeat step 3 for 3 iterations within the same call as the first iteration. Wait for at least 5 seconds between each iteration of the data transfer.
5. Calculate and record the average application layer data throughput across three iterations. Additionally, count and record the overall number of ACK and NACK/DTX on the PUSCH/PUCCH during the test interval purely for information purposes.
6. Record the IP address type (IPv4 or IPv6) used during the TCP data transfers.

7. Using the values in Table 5.4.4-2 (for IPv6) and Table 5.4.4-3 (for IPv4), determine the reduction from PHY reference fractional throughput value listed in Table A.2.1.1.3-1 to obtain reference Application Layer Throughput value.

A.3.1.1.2 5G NR /TCP Downlink Throughput /Conducted/Fading/2Rx TDD/FR1 PDSCH mapping Type A performance - 2x2 MIMO for SA and NSA

A.3.1.1.2.1 Definition

The UE application layer downlink performance for TCP is determined by the UE application layer TCP throughput.

A.3.1.1.2.2 Test Purpose

To measure the performance of the 5G NR UE using fixed reference channels and under 2 receive antenna conditions while downloading TCP based data in fading channel environment. The duplex mode is TDD.

A.3.1.1.2.3 Test Parameters

The test points to be used in this test are defined in Table A.3.1.1.2.3-1. Details of these test points are available in Annex D with the test points below referenced directly from Table D.1-2

Table A.3.1.1.2.3-1: FR1 TDD 2RX

TS 38.521-4 Reference	Test num.	Reference channel	Bandwidth (MHz) / Subcarrier spacing (kHz)	Modulation format and code rate	TDD UL-DL pattern	Propagation condition	Correlation matrix and antenna configuration	Reference value		Comment
								Fraction of maximum throughput (%)	SNR (dB)	
5.2.2.2.1_1 2Rx TDD	1-3	R.PDSCH.2-4.1 TDD	40 / 30	256QAM, 0.82	FR1.3 0-1	TDLA30-10	2x2, ULA Low	70	26.3	Large TBS
5.2.2.2.1_1 2Rx TDD	1-4	R.PDSCH.2-2.1 TDD	40 / 30	16QAM, 0.48	FR1.3 0-1	TDLC300-100	2x2, ULA Low	30	2.5	High BLER
5.2.2.2.1_1 2Rx TDD	1-1	R.PDSCH.2-1.1 TDD	40 / 30	QPSK, 0.30	FR1.3 0-1A	TDLB100-400	2x2, ULA Low	70	-0.2	High channel variation
5.2.2.2.1_1 2Rx TDD	2-1	R.PDSCH.2-3.1 TDD	40 / 30	64QAM, 0.50	FR1.3 0-1	TDLA30-10	2x2, ULA Low	70	20.8	High throughput Baseline Rx
5.2.2.2.1_2 2Rx TDD	3-1	R.PDSCH.2-2.2 TDD	40 / 30	16QAM, 0.48	FR1.3 0-1	TDLA30-10	2x2, ULA Medium	70	19.0	High throughput Enhanced Rx

Other test parameters are defined in TS 38.521-4 [3] Tables 5.2.2.2.1_1.4-1 and 5.2.2.2.1_1.4-2.

A.3.1.1.2.4 Test Description

A.3.1.1.2.4.1 Initial Conditions

Initial conditions are a set of test configurations the UE needs to be tested in and the steps for the SS to take with the UE to reach the correct measurement state. Apply the Initial conditions defined in TS 38.521-4 [3] clause 5.2.2.2.1_1.3.1 with the following additional steps and/or exceptions

1.1 Connect an application server to the IP output of the SS.

1.2 For an embedded configuration, ensure that the UE has an client test application available. For a tethered configuration, tether the UE to a laptop configured with TCP client software using the appropriate UE to PC interface Modem or Network Interface Connection (NIC) drivers. 5. For NSA case, the E-UTRA anchor is configured as per Annex E. Ensure the UE is in RRC_CONNECTED State (on NR for SA and on E-UTRA for NSA with NR PSCell added). Message contents are as per TS 38.521-4 [3] clause 5.2.2.2.1_1.3.3 and 5.2.2.2.1_1.3.3_2 and Tables 5.2.2.2.1_1.3.3_1-1 through 5.2.2.2.1_1.3.3_1-4.

A.3.1.1.2.4.2 Procedure

1. SS transmits PDSCH via PDCCH DCI format 1_1 for C_RNTI to transmit the DL RMC according to TS 38.521-4 [3] Table 5.2.2.2.1.0-2. The SS sends downlink MAC padding bits on the DL RMC.
2. Set the parameters of the Modulation format and code rate, reference channel, the propagation condition, the correlation matrix and the SNR according to TS 38.521-4 [3] Tables 5.2.2.2.1_1.4-1 and 5.2.2.2.1_1.4-2 as applicable to the test points in Table A.3.1.1.2.3-1.
3. Using the data client, begin TCP downlink data transfer from the application server. Wait for 15 seconds and then start recording the TCP throughput result. (This is iteration 1) Continue data transfer for the test duration outlined in Table A.1-1-1. Repeat transfer for iterations [2-3] within the same call as the first iteration.
4. Repeat step 3 for 3 iterations within the same call as the first iteration. Wait for at least 5 seconds between each iteration of the data transfer.
5. Calculate and record the average application layer data throughput across three iterations. Additionally, count and record the overall number of ACK and NACK/DTX on the PUSCH/PUCCH during the test interval purely for information purposes.
6. Record the IP address type (IPv4 or IPv6) used during the TCP data transfers.
7. Using the values in Table 5.4.4-2 (for IPv6) and Table 5.4.4-3 (for IPv4), determine the reduction from PHY reference fractional throughput value listed in Table A.2.1.1.3-1 to obtain reference Application Layer Throughput value.

A.3.1.2 5G NR /TCP Downlink Throughput /Conducted/Fading/FRC/4Rx for SA and NSA

A.3.1.2.1 5G NR /TCP Downlink Throughput /Conducted/Fading/FRC/4Rx FDD/FR1 PDSCH mapping Type A performance - for SA and NSA

A.3.1.2.1.1 Definition

The UE application layer downlink performance for TCP is determined by the UE application layer TCP throughput.

A.3.1.2.1.2 Test Purpose

To measure the performance of the 5G NR UE using fixed reference channels and under 2 receive antenna conditions while downloading TCP based data in fading channel environment. The duplex mode is FDD.

A.3.1.2.1.3 Test Parameters

The test points to be used in this test are defined in Table A.3.1.2.1.3-1. Details of these test points are available in Annex D with the test points below referenced directly from Table D.1-2.

Table A.3.1.2.1.3-1: FR1 FDD 4Rx

Subtest Number	Propagation condition	Correlation matrix and antenna configuration	TS 38.521-4 Reference			
			Test Case	Test Number	Fraction of maximum throughput (%)	SNR (dB)
1	TDLA30-10	2x4, ULA Low	5.2.3.1.1_1 4Rx FDD	1-3	70	22.0
2	TDLC300-100	2x4, ULA Low	5.2.3.1.1_1 4Rx FDD	1-4	30	-0.6
3	TDLB100-400	2x4, ULA Low	5.2.3.1.1_1 4Rx FDD	1-1	70	-2.6
4	TDLA30-10	4x4, ULA Low	5.2.3.1.1_1 4Rx FDD	4-1	70	16.6
5	TDLA30-10	4x4, ULA Medium A	5.2.3.1.1_1 4Rx FDD	5-1	70	23.3

Other test parameters are defined in TS 38.521-4 [3] Tables 5.2.3.1.1_1.4-1 and 5.2.3.1.1_1.4-2.

A.3.1.2.1.4 Test Description

A.3.1.2.1.4.1 Initial Conditions

Initial conditions are a set of test configurations the UE needs to be tested in and the steps for the SS to take with the UE to reach the correct measurement state. Apply the Initial conditions defined in TS 38.521-4 [3] clause 5.2.3.1.1_1.3.1 with the following additional steps and/or exceptions

1.1 Connect an application server to the IP output of the SS.

1.2 For an embedded configuration, ensure that the UE has an client test application available. For a tethered configuration, tether the UE to a laptop configured with TCP client software using the appropriate UE to PC interface Modem or Network Interface Connection (NIC) drivers. 5. For NSA case, the E-UTRA anchor is configured as per Annex E. Ensure the UE is in RRC_CONNECTED State (on NR for SA and on E-UTRA for NSA with NR PSCell added). Message contents are as per TS 38.521-4 [3] clause 5.2.3.1.1_1.3.3 and 5.2.3.1.1_1.3.3_2 and Tables 5.2.3.1.1_1.3.3_1-1 through 5.2.3.1.1_1.3.3_1-4.

A.3.1.2.1.4.2 Procedure

1. SS transmits PDSCH via PDCCH DCI format 1_1 for C_RNTI to transmit the DL RMC according to TS 38.521-4 [3] Table 5.2.3.1.1.0-2. The SS sends downlink MAC padding bits on the DL RMC.
2. Set the parameters of the bandwidth, MCS, reference channel, the propagation condition, the correlation matrix and the SNR according to TS 38.521-4 [3] Tables 5.2.3.1.1_1.4-1 and 5.2.3.1.1_1.4-2 as applicable to the test points in Table A.3.1.2.1.3-1.
3. Using the data client, begin TCP downlink data transfer from the application server. Wait for 15 seconds and then start recording the TCP throughput result. (This is iteration 1) Continue data transfer for the test duration outlined in Table A.1-14. Repeat transfer for iterations [2-3] within the same call as the first iteration.
4. Repeat step 3 for 3 iterations within the same call as the first iteration. Wait for at least 5 seconds between each iteration of the data transfer.

5. Calculate and record the average application layer data throughput across three iterations. Additionally, count and record the overall number of ACK and NACK/DTX on the PUSCH/PUCCH during the test interval purely for information purposes.
6. Record the IP address type (IPv4 or IPv6) used during the TCP data transfers.
7. Using the values in Table 5.4.4-2 (for IPv6) and Table 5.4.4-3 (for IPv4), determine the reduction from PHY reference fractional throughput value listed in Table A.2.1.1.3-1 to obtain reference Application Layer Throughput value.

A.3.1.2.2 5G NR /TCP Downlink Throughput /Conducted/Fading/FRC/4Rx TDD/FR1 PDSCH mapping Type A performance - for SA and NSA

A.3.1.2.2.1 Definition

The UE application layer downlink performance for TCP is determined by the UE application layer TCP throughput.

A.3.1.2.2.2 Test Purpose

To measure the performance of the 5G NR UE using fixed reference channels and under 4 receive antenna conditions while downloading TCP based data in fading channel environment. The duplex mode is TDD.

A.3.1.2.2.3 Test Parameters

The test points to be used in this test are defined in Table A.3.1.2.2.3-1. Details of these test points are available in Annex D with the test points below referenced directly from Table D.1-4.

Table A.3.1.2.2.3-1: FR1 TDD 4Rx

TS 38.521-4 Reference	Test num.	Reference channel	Bandwidth (MHz) / Subcarrier spacing (kHz)	Modulation format and code rate	TDD UL-DL pattern	Propagation condition	Correlation matrix and antenna configuration	Reference value		Comment
								Fraction of maximum throughput (%)	SNR (dB)	
5.2.3.2.1_1 4Rx TDD	1-3	R.PDSCH.2-4.1 TDD	40 / 30	256QAM, 0.82	FR1.30-1	TDLA30-10	2x4, ULA Low	70	22.5	Large TBS
5.2.3.2.1_1 4Rx TDD	1-4	R.PDSCH.2-2.1 TDD	40 / 30	16QAM, 0.48	FR1.30-1	TDLC300-100	2x4, ULA Low	30	-0.3	High BLER
5.2.3.2.1_1 4Rx TDD	1-1	R.PDSCH.2-1.1 TDD	40 / 30	QPSK, 0.30	FR1.30-1A	TDLB100-400	2x4, ULA Low	70	-3.1	High channel variation
5.2.3.2.1_1 4Rx TDD	4-1	R.PDSCH.2-2.4 TDD	40 / 30	16QAM, 0.48	FR1.30-1	TDLA30-10	4x4, ULA Low	70	16.4	High throughput Baseline Rx
5.2.3.2.1_1 4Rx TDD	5-1	R.PDSCH.2-2.3 TDD	40 / 30	16QAM, 0.48	FR1.30-1	TDLA30-10	4x4, ULA Medium A	70	23.9	High throughput Enhanced Rx

Other test parameters are defined in TS 38.521-4 [3] Tables 5.2.3.2.1_1.4-1 and 5.2.3.2.1_1.4-2.

A.3.1.2.2.4 Test Description

A.3.1.2.2.4.1 Initial Conditions

Initial conditions are a set of test configurations the UE needs to be tested in and the steps for the SS to take with the UE to reach the correct measurement state. Apply the Initial conditions defined in TS 38.521-4 [3] clause 5.2.3.2.1_1.3.1 with the following additional steps and/or exceptions

- 1.1 Connect an application server to the IP output of the SS.
- 1.2 For an embedded configuration, ensure that the UE has an client test application available. For a tethered configuration, tether the UE to a laptop configured with TCP client software using the appropriate UE to PC interface Modem or Network Interface Connection (NIC) drivers. 5. For NSA case, the E-UTRA anchor is

configured as per Annex E. Ensure the UE is in RRC_CONNECTED State (on NR for SA and on E-UTRA for NSA with NR PSCell added). Message contents are as per TS 38.521-4 [3] clauses 5.2.3.2.1_1.3.3 and 5.2.3.2.1_1.3.3_2 and Tables 5.2.3.2.1_1.3.3_1-1 through 5.2.3.2.1_1.3.3_1-4.

A.3.1.2.2.4.2 Procedure

1. SS transmits PDSCH via PDCCH DCI format 1_1 for C_RNTI to transmit the DL RMC according to TS 38.521-4 [3] Table 5.2.3.2.1.0-2. The SS sends downlink MAC padding bits on the DL RMC.
2. Set the parameters of the Modulation format and code rate, reference channel, the propagation condition, the correlation matrix and the SNR according to TS 38.521-4 [3] Tables 5.2.3.2.1_1.4-1 and 5.2.3.2.1_1.4-2 as applicable to the test points in Table A.3.1.2.2.3-1.
3. Using the data client, begin TCP downlink data transfer from the application server. Wait for 15 seconds and then start recording the TCP throughput result. (This is iteration 1) Continue data transfer for the test duration outlined in Table A.1-1-1. Repeat transfer for iterations [2-3] within the same call as the first iteration.
4. Repeat step 3 for 3 iterations within the same call as the first iteration. Wait for at least 5 seconds between each iteration of the data transfer.
5. Calculate and record the average application layer data throughput across three iterations. Additionally, count and record the overall number of ACK and NACK/DTX on the PUSCH/PUCCH during the test interval purely for information purposes.
6. Record the IP address type (IPv4 or IPv6) used during the TCP data transfers.
7. Using the values in Table 5.4.4-2 (for IPv6) and Table 5.4.4-3 (for IPv4), determine the reduction from PHY reference fractional throughput value listed in Table A.2.1.1.3-1 to obtain reference Application Layer Throughput value.

CONDUCTED UDP DOWNLINK – STATIC CHANNEL

A.4 5G NR /UDP Downlink Throughput /Conducted/Static Peak Throughput for SA and NSA

A.4.1 5G NR /UDP Downlink Throughput /Conducted/Static Channel Peak Throughput tests for SA and NSA

A.4.1.1 5G NR /UDP Downlink Throughput /Conducted/Static Channel/ SA and NSA (no Downlink Split Bearer)

A.4.1.1.1 Definition

The UE application layer downlink performance for UDP under different static environment is determined by the UE application layer UDP throughput.

A.4.1.1.2 Test Purpose

To measure the performance of the 5G NR UE while downloading UDP based data in a static channel environment.

A.4.1.1.3 Test Parameters

The common test parameters are defined in TS 38.521-4 [3] Table 5.5.1.3-1. The parameters specified in TS 38.521-4 [3] Table 5.5.1.3-2 are applicable for tests on FDD bands and parameters specified in TS 38.521-4 [3] Table 5.5.1.3-3 are applicable for tests on TDD bands. CORESET details are in TS 38.521-4 [3] Table 5.5.1.3-4 and MCS indices for indicated UE capabilities are in TS 38.521-4 [4] Table 5.5.1.3-5. The test parameter selection procedure is defined in TS 38.521-4 [3] clause 5.5.1.3.1. In addition, the following test statements from TS 38.521-4 [3] clause 5.5.1.3 apply:

- Unless otherwise stated, no user data is scheduled on slot #0, 10 and 11 within 20 ms for SCS 15 kHz.
- Unless otherwise stated, no user data is scheduled on slot #0, 20 and 21 within 20 ms for SCS 30 kHz.

For NSA case, since this test is not focused on aggregated throughput, the E-UTRA anchor is functional link and is setup via the parameters defined in Annex E.

Test point is detailed in Annex D.1-5.

Table A.4.1.1.3-1: FR1 Static Channel Test Point

TS 38.521-4 Reference	Reference channel	Bandwidth (MHz) / Subcarrier spacing (kHz)	Modulation format and code rate	TDD UL-DL pattern	Propagation condition	PHY Reference value		Comment
						Fraction of maximum throughput (%)	SNR (dB)	
5.5.1	As per tables in TS 38.521-4 [3] clause 5.5.1.3 and test parameter selection as per TS 38.521-4 [3] clause 5.5.1.3.1.				Static/ Clean Channel	85 %	No external noise sources are applied	Peak Throughput

A.4.1.1.4 Test Description

A.4.1.1.4.1 Initial Conditions

Initial conditions are a set of test configurations the UE needs to be tested in and the steps for the SS to take with the UE to reach the correct measurement state. Apply the Initial conditions defined in TS 38.521-4 [3] clause 5.5.1.4.1 with the following additional steps and/or exceptions

- 1.1 Connect an application server to the IP output of the SS.
- 1.2 For an embedded configuration, ensure that the UE has an client test application available. For a tethered configuration, tether the UE to a laptop configured with FTP client software using the appropriate UE to PC interface Modem or Network Interface Connection (NIC) drivers. 5. For NSA case, the E-UTRA anchor is configured as per Annex E. Ensure the UE is in RRC_CONNECTED State. Message contents are as per TS 38.521-4 [3] Table 5.5.1.4.3-1 through Table 5.5.1.4.3-8.

A.4.1.1.4.2 Test Procedure

1. SS sets the parameters of the bandwidth, MCS and DL reference channel (RMC) according to the test parameter selection procedure defined in TS 38.521-4 [3] clause 5.5.1.3.1. The SS transmits PDSCH via PDCCH DCI format 1_1 for C_RNTI to transmit the DL RMC.
2. SS sends uplink scheduling information for each UL HARQ process via PDCCH DCI format 0_1 for C_RNTI to schedule the UL RMC over PUSCH according to parameters set during initial conditions.
3. Using the UDP data client, begin UDP downlink data transfer from the application server. Wait for 15 seconds and then start recording the UDP throughput result. (This is iteration 1) Continue data transfer for the test duration outlined in Table A.1-1.
4. Repeat step 3 for 3 iterations within the same call as the first iteration. Wait for at least 5 seconds between each iteration of the data transfer.
5. Calculate and record the average application layer data throughput across three iterations. Additionally, count and record the overall number of ACK and NACK/DTX on the PUSCH/PUCCH during the test interval. Record the IP address type (IPv4 or IPv6) used during the UDP data transfers.

6. Using the values in Table 5.4.4-2 (for IPv6) and Table 5.4.4-3 (for IPv4), determine the reduction from PHY reference fractional throughput value listed in Table A.2.1.1.3-1 to obtain reference Application Layer UDP Throughput value.

A.4.1.2 5G NR /UDP Downlink Throughput /Conducted/Static Channel/NSA (Downlink Split Bearer)A.4.1.2.1 Definition

The UE application layer downlink performance for UDP under different static environment is determined by the UE application layer UDP throughput.

A.4.1.2.2 Test Purpose

To measure the performance of the 5G NR UE while downloading UDP based data in a static channel environment.

A.4.1.2.3 Test Parameters

The common test parameters are defined in TS 38.521-4 [3] Table 9.4B.1.1.3-1. The parameters specified in TS 38.521-4 [3] Table 9.4B.1.1.3-2 are applicable for tests on FDD bands and parameters specified in TS 38.521-4 [3] Table 9.4B.1.1.3-3 are applicable for tests on TDD bands. CORESET details are in TS 38.521-4 [3] Table 9.4B.1.1.3-4 and MCS indices for indicated UE capabilities are in TS 38.521-4 [4] Table 9.4B.1.1.3-5. The test parameter selection procedure is defined in TS 38.521-4 [3] clause 9.4B.1.1.3.1. In addition, the following test statements from TS 38.521-4 [3] clause 9.4B.1.1.3 apply:

- Unless otherwise stated, no user data is scheduled on slot #0, 10 and 11 within 20 ms for SCS 15 kHz for the NR cell.
- Unless otherwise stated, no user data is scheduled on slot #0, 20 and 21 within 20 ms for SCS 30 kHz for the NR cell.

For NSA case, the focus in this test is to measure aggregated throughput therefore data rate over the E-UTRA carrier is also included in the measurements. The aggregated data rate over E-UTRA and NR carriers is carried out once the aforementioned test parameter selection in TS 38.521-4 [3] clause 9.4B.1.1.3.1 is completed.

Test point is detailed in Annex D.1-5.

Table A.4.1.2.3-1: FR1 Static Channel Test Point

TS 38.521-4 Reference	Reference channel	Bandwidth (MHz) / Subcarrier spacing (kHz)	Modulation format and code rate	TDD UL-DL pattern	Propagation condition	PHY Reference value		Comment
						Fraction of maximum throughput (%)	SNR (dB)	
5.5.1	As per tables in TS 38.521-4 [3] clause 5.5.1.3 and test parameter selection as per TS 38.521-4 [3] clause 5.5.1.3.1.				Static/ Clean Channel	85 %	No external noise sources are applied	Peak Throughput

A.4.1.2.4 Test Description

A.4.1.2.4.1 Initial Conditions

Initial conditions are a set of test configurations the UE needs to be tested in and the steps for the SS to take with the UE to reach the correct measurement state. Apply the Initial conditions defined in TS 38.521-4 [3] clause 9.4B.1.1.4.1 with the following additional steps and/or exceptions:

- 1.1 Connect an application server to the IP output of the SS.

1.2 For an embedded configuration, ensure that the UE has an client test application available. For a tethered configuration, tether the UE to a laptop configured with FTP client software using the appropriate UE to PC interface Modem or Network Interface Connection (NIC) drivers.

5. Setup an NSA call with E-UTRA anchor initially scheduled as per Annex E.

A.4.1.2.4.2 Test Procedure

1. SS sets the parameters of the bandwidth, MCS and DL reference channel (RMC) according to the test parameter selection procedure defined in TS 38.521-4 [3] clause 5.5.1.3.1. The SS transmits PDSCH via PDCCH DCI format 1_1 for C_RNTI to transmit the DL RMC.
2. SS sends uplink scheduling information for each UL HARQ process via PDCCH DCI format 0_1 for C_RNTI to schedule the UL RMC over PUSCH according to parameters set during initial conditions . The purpose of this scheduling is to accommodate for UDP UL ACK/NACK feedback transmissions.
3. Using the data client, begin UDP downlink data transfer from the application server. Wait for 15 seconds and then start recording the UDP throughput result. (This is iteration 1) Continue data transfer for the test duration outlined in Table A.1-1.
4. Repeat step 3 for 3 iterations within the same call as the first iteration. Wait for at least 5 seconds between each iteration of the data transfer.
5. Calculate and record the average application layer data throughput across three iterations. Additionally, count and record the overall number of ACK and NACK/DTX on the PUSCH/PUCCH during the test interval. Record the IP address type (IPv4 or IPv6) used during the UDP data transfers.
6. Using the values in Table 5.4.4-2 (for IPv6) and Table 5.4.4-3 (for IPv4), determine the reduction from PHY reference fractional throughput value listed in Table A.4.1.2.3-1 to obtain reference Application Layer Throughput value.

CONDUCTED UDP DOWNLINK – FADING (FRC)

A.5 5G NR /UDP Downlink Throughput /Conducted for Fixed Reference Channel (FRC) Scenarios with Fading for SA and NSA

A.5.1 5G NR /UDP Downlink Throughput /Conducted/Fading/FRC for SA and NSA

A.5.1.1 5G NR /UDP Downlink Throughput /Conducted/Fading/FRC/2Rx for SA and NSA

A.5.1.1.1 5G NR /UDP Downlink Throughput /Conducted/Fading/2Rx/FR1 PDSCH mapping Type A performance - 2x2 MIMO for SA and NSA

A.5.1.1.1.1 Definition

The UE application layer downlink performance for UDP is determined by the UE application layer UDP throughput.

A.5.1.1.1.2 Test Purpose

To measure the performance of the 5G NR UE using fixed reference channels and under 2 receive antenna conditions while downloading UDP based data in fading channel environment. The duplex mode is FDD.

A.5.1.1.1.3 Test Parameters

The test points to be used in this test are defined in Table A.5.1.1.1.3-1. Details of these test points are available in Annex D with the test points below referenced directly from Table D.1-1.

Table A.5.1.1.1.3-1: FR1 FDD 2RX

TS 38.521-4 Reference	Test num.	Reference channel	Modulation format	Propagation condition	Correlation matrix and antenna configuration	Reference value		Comment
						Fraction of maximum throughput (%)	SNR (dB)	
5.2.2.1.1_1 2Rx FDD	1-3	R.PDSCH.1-4.1 FDD	256AM, 0.82	TDLA30-10	2x2, ULA Low	70	25.6	Large TBS
5.2.2.1.1_1 2Rx FDD	1-4	R.PDSCH.1-2.1 FDD	16QAM, 0.48	TDLC300-100	2x2, ULA Low	30	2	High BLER
5.2.2.1.1_1 2Rx FDD	1-1	R.PDSCH.1-1.1 FDD	QPSK, 0.30	TDLB100-400	2x2, ULA Low	70	0.1	High channel variation
5.2.2.1.1_1 2Rx FDD	2-1	R.PDSCH.1-3.1 FDD	64QAM, 0.51	TDLA30-10	2x2, ULA Low	70	20.4	High throughput Baseline Rx
5.2.2.1.1_2 2Rx FDD	3-1	R.PDSCH.1-2.2 FDD	16QAM, 0.48	TDLA30-10	2x2, ULA Medium	70	18.6	High throughput Enhanced Rx

Other test parameters are defined in TS 38.521-4 [3] Tables 5.2.2.1.1_1.4-1 and 5.2.2.1.1_1.4-2.

A.5.1.1.1.4 Test Description

A.5.1.1.1.4.1 Initial Conditions

Initial conditions are a set of test configurations the UE needs to be tested in and the steps for the SS to take with the UE to reach the correct measurement state. Apply the Initial conditions defined in TS 38.521-4 [3] clause 5.2.2.1.1_1.3.1 with the following additional steps and/or exceptions.

1.1 Connect an application server to the IP output of the SS.

1.2 For an embedded configuration, ensure that the UE has an client test application available. For a tethered configuration, tether the UE to a laptop configured with TCP client software using the appropriate UE to PC interface Modem or Network Interface Connection (NIC) drivers. 5. For NSA case, the E-UTRA anchor is configured as per Annex E. Ensure the UE is in RRC_CONNECTED State (on NR for SA and on E-UTRA for NSA with NR PSCell added). Message contents are as per TS 38.521-4 [3] clause 5.2.2.1.1_1.3.3 and 5.2.2.1.1_1.3.3_2 and Tables 5.2.2.1.1_1.3.3_1-1 through 5.2.2.1.1_1.3.3_1-4.

A.5.1.1.1.4.2 Procedure

1. SS transmits PDSCH via PDCCH DCI format 1_1 for C_RNTI to transmit the DL RMC according to TS 38.521-4 [3] Table 5.2.2.1.1.0-2. The SS sends downlink MAC padding bits on the DL RMC.
2. Set the parameters of the Modulation format and code rate, reference channel, the propagation condition, the correlation matrix and the SNR according to TS 38.521-4 [3] Tables 5.2.2.1.1_1.4-1 and 5.2.2.1.1_1.4-2 as applicable to the test points in Table A.5.1.1.1.3-1.
3. Using UDP data client, begin UDP downlink data transfer from the application server. Wait for 15 seconds and then start recording the UDP throughput result. (This is iteration 1) Continue data transfer for the test duration outlined in Table A.1.1-1 Repeat transfer for iterations [2-3] within the same call as the first iteration.
4. Repeat step 3 for 3 iterations within the same call as the first iteration. Wait for at least 5 seconds between each iteration of the data transfer.

5. Calculate and record the average application layer data throughput across three iterations. Additionally, count and record the overall number of ACK and NACK/DTX on the PUSCH/PUCCH during the test interval purely for information purposes.
6. Record the IP address type (IPv4 or IPv6) used during the UDP data transfers.
7. Using the values in Table 5.4.4-2 (for IPv6) and Table 5.4.4-3 (for IPv4), determine the reduction from PHY reference fractional throughput value listed in Table A.2.1.1.3-1 to obtain reference Application Layer Throughput value.

A.5.1.1.2 5G NR /UDP Downlink Throughput /Conducted/Fading/2Rx TDD/FR1 PDSCH mapping Type A performance - 2x2 MIMO for SA and NSA

A.5.1.1.2.1 Definition

The UE application layer downlink performance for UDP is determined by the UE application layer UDP throughput.

A.5.1.1.2.2 Test Purpose

To measure the performance of the 5G NR UE using fixed reference channels and under 2 receive antenna conditions while downloading UDP based data in fading channel environment. The duplex mode is TDD.

A.5.1.1.2.3 Test Parameters

The test points to be used in this test are defined in Table A.5.1.1.2.3-1. Details of these test points are available in Annex D with the test points below referenced directly from Table D.1-2.

Table A.5.1.1.2.3-1: FR1 TDD 2RX

TS 38.521-4 Reference	Test num.	Reference channel	Bandwidth (MHz) / Subcarrier spacing (kHz)	Modulation format and code rate	TDD UL-DL pattern	Propagation condition	Correlation matrix and antenna configuration	Reference value		Comment
								Fraction of maximum throughput (%)	SNR (dB)	
5.2.2.2.1_1 2Rx TDD	1-3	R.PDSCH.2-4.1 TDD	40 / 30	256QAM, 0.82	FR1.3 0-1	TDLA30-10	2x2, ULA Low	70	26.3	Large TBS
5.2.2.2.1_1 2Rx TDD	1-4	R.PDSCH.2-2.1 TDD	40 / 30	16QAM, 0.48	FR1.3 0-1	TDLC300-100	2x2, ULA Low	30	2.5	High BLER
5.2.2.2.1_1 2Rx TDD	1-1	R.PDSCH.2-1.1 TDD	40 / 30	QPSK, 0.30	FR1.3 0-1A	TDLB100-400	2x2, ULA Low	70	-0.2	High channel variation
5.2.2.2.1_1 2Rx TDD	2-1	R.PDSCH.2-3.1 TDD	40 / 30	64QAM, 0.50	FR1.3 0-1	TDLA30-10	2x2, ULA Low	70	20.8	High throughput Baseline Rx
5.2.2.2.1_2 2Rx TDD	3-1	R.PDSCH.2-2.2 TDD	40 / 30	16QAM, 0.48	FR1.3 0-1	TDLA30-10	2x2, ULA Medium	70	19.0	High throughput Enhanced Rx

Other test parameters are defined in TS 38.521-4 [3] Tables 5.2.2.2.1_1.4-1 and 5.2.2.2.1_1.4-2.

A.5.1.1.2.4 Test Description

A.5.1.1.2.4.1 Initial Conditions

Initial conditions are a set of test configurations the UE needs to be tested in and the steps for the SS to take with the UE to reach the correct measurement state. Apply the Initial conditions defined in TS 38.521-4 [3] clause 5.2.2.2.1_1.3.1 with the following additional steps and/or exceptions

- 1.1 Connect an application server to the IP output of the SS.
- 1.2 For an embedded configuration, ensure that the UE has an client test application available. For a tethered configuration, tether the UE to a laptop configured with UDP client software using the appropriate UE to PC interface Modem or Network Interface Connection (NIC) drivers.
5. For NSA case, the E-UTRA anchor is configured as per Annex E. Ensure the UE is in RRC_CONNECTED State (on NR for SA and on E-UTRA for NSA with NR PSCell added). Message contents are as per TS 38.521-4 [3] clause 5.2.2.2.1_1.3.3 and 5.2.2.2.1_1.3.3_2 and Tables 5.2.2.2.1_1.3.3_1-1 through 5.2.2.2.1_1.3.3_1-4.

A.5.1.1.2.4.2 Procedure

1. SS transmits PDSCH via PDCCH DCI format 1_1 for C_RNTI to transmit the DL RMC according to TS 38.521-4 [3] Table 5.2.2.2.1.0-2. The SS sends downlink MAC padding bits on the DL RMC.
2. Set the parameters of the Modulation format and code rate, reference channel, the propagation condition, the correlation matrix and the SNR according to TS 38.521-4 [3] Tables 5.2.2.2.1_1.4-1 and 5.2.2.2.1_1.4-2 as applicable to the test points in Table A.5.1.1.2.3-1.
3. Using UDP data client, begin UDP downlink data transfer from the application server. Wait for 15 seconds and then start recording the UDP throughput result. (This is iteration 1) Continue data transfer for the test duration outlined in Table A.1.1-1 Repeat transfer for iterations [2-3] within the same call as the first iteration.
4. Repeat step 3 for 3 iterations within the same call as the first iteration. Wait for at least 5 seconds between each iteration of the data transfer.
5. Calculate and record the average application layer data throughput across three iterations. Additionally, count and record the overall number of ACK and NACK/DTX on the PUSCH/PUCCH during the test interval purely for information purposes.
6. Record the IP address type (IPv4 or IPv6) used during the UDP data transfers.
7. Using the values in Table 5.4.4-2 (for IPv6) and Table 5.4.4-3 (for IPv4), determine the reduction from PHY reference fractional throughput value listed in Table A.2.1.1.3-1 to obtain reference Application Layer Throughput value.

A.5.1.2 5G NR /UDP Downlink Throughput /Conducted/Fading/FRC/4Rx for SA and NSA

A.5.1.2.1 5G NR /UDP Downlink Throughput /Conducted/Fading/FRC/4Rx FDD/FR1 PDSCH mapping Type A performance - 4x4 MIMO for SA and NSA

A.5.1.2.1.1 Definition

The UE application layer downlink performance for UDP is determined by the UE application layer UDP throughput.

A.5.1.2.1.2 Test Purpose

To measure the performance of the 5G NR UE using fixed reference channels and under 4 receive antenna conditions while downloading UDP based data in fading channel environment. The duplex mode is FDD.

A.5.1.2.1.3 Test Parameters

The test points to be used in this test are defined in Table A.5.1.2.1.3-1. Details of these test points are available in Annex D with the test points below referenced directly from Table D.1-3.

Table A.5.1.2.1.3-1: FR1 FDD 4RX

TS 38.521-4 Reference	Test num .	Bandwidth (MHz) / Subcarrier spacing (kHz)	Referenc e channel	Modulatio n format	Propagatio n condition	Correlation matrix and antenna configuratio n	Reference value		Commen t
							Fraction of maximum throughpu t (%)	SN R (dB)	
5.2.3.1.1_ 1 4Rx FDD	1-3	R.PDSCH.1 -4.1 FDD	10 / 15	256QAM, 0.82	TDLA30-10	2x4, ULA Low	70	22.0	Large TBS
5.2.3.1.1_ 1 4Rx FDD	1-4	R.PDSCH.1 -2.1 FDD	10 / 15	16QAM, 0.48	TDLC300- 100	2x4, ULA Low	30	-0.6	High BLER
5.2.3.1.1_ 1 4Rx FDD	1-1	R.PDSCH.1 -1.1 FDD	10 / 15	QPSK, 0.30	TDLB100- 400	2x4, ULA Low	70	-2.6	High channel variation
5.2.3.1.1_ 1 4Rx FDD	4-1	R.PDSCH.1 -2.4 FDD	10 / 15	16QAM, 0.48	TDLA30-10	4x4, ULA Low	70	16.6	High throughpu t Baseline Rx
5.2.3.1.1_ 1 4Rx FDD	5-1	R.PDSCH.1 -2.3 FDD	10 / 15	16QAM, 0.48	TDLA30-10	4x4, ULA Medium A	70	23.3	High throughpu t Enhanced Rx

Other test parameters are defined in TS 38.521-4 [3] Tables 5.2.3.1.1_1.4-1 and 5.2.3.1.1_1.4-2.

A.5.1.2.1.4 Test Description

A.5.1.2.1.4.1 Initial Conditions

Initial conditions are a set of test configurations the UE needs to be tested in and the steps for the SS to take with the UE to reach the correct measurement state. Apply the Initial conditions defined in TS 38.521-4 [3] clause 5.2.3.1.1_1.3.1 with the following additional steps and/or exceptions.

- 1.1 Connect an application server to the IP output of the SS.
- 1.2 For an embedded configuration, ensure that the UE has an client test application available. For a tethered configuration, tether the UE to a laptop configured with UDP client software using the appropriate UE to PC interface Modem or Network Interface Connection (NIC) drivers.
5. For NSA case, the E-UTRA anchor is configured as per Annex E. Ensure the UE is in RRC_CONNECTED State (on NR for SA and on E-UTRA for NSA with NR PSCell added). Message contents are as per TS 38.521-4 [3] clause 5.2.3.1.1_1.3.3 and 5.2.3.1.1_1.3.3_2 and Tables 5.2.3.1.1_1.3.3_1-1 through 5.2.3.1.1_1.3.3_1-4.

A.5.1.1.1.4.2 Procedure

1. SS transmits PDSCH via PDCCH DCI format 1_1 for C_RNTI to transmit the DL RMC according to TS 38.521-4 [3] Table 5.2.3.1.1.0-2. The SS sends downlink MAC padding bits on the DL RMC.
2. Set the parameters of the Modulation format and code rate, reference channel, the propagation condition, the correlation matrix and the SNR according to TS 38.521-4 [3] Tables 5.2.3.1.1_1.4-1 and 5.2.3.1.1_1.4-2 as applicable to the test points in Table A.5.1.2.1.3-1.

3. Using UDP data client, begin UDP downlink data transfer from the application server. Wait for 15 seconds and then start recording the UDP throughput result. (This is iteration 1) Continue data transfer for the test duration outlined in Table.A.1.1-1 Repeat transfer for iterations [2-3] within the same call as the first iteration.
4. Repeat step 3 for 3 iterations within the same call as the first iteration. Wait for at least 5 seconds between each iteration of the data transfer.
5. Calculate and record the average application layer data throughput across three iterations. Additionally, count and record the overall number of ACK and NACK/DTX on the PUSCH/PUCCH during the test interval purely for information purposes.
6. Record the IP address type (IPv4 or IPv6) used during the UDP data transfers.
7. Using the values in Table 5.4.4-2 (for IPv6) and Table 5.4.4-3 (for IPv4), determine the reduction from PHY reference fractional throughput value listed in Table A.2.1.1.3-1 to obtain reference Application Layer Throughput value.

A.5.1.2.2 5G NR /UDP Downlink Throughput /Conducted/Fading/4Rx TDD/FR1 PDSCH mapping Type A performance - 4x4 MIMO for SA and NSA

A.5.1.2.2.1 Definition

The UE application layer downlink performance for UDP is determined by the UE application layer UDP throughput.

A.5.1.2.2.2 Test Purpose

To measure the performance of the 5G NR UE using fixed reference channels and under 4 receive antenna conditions while downloading UDP based data in fading channel environment. The duplex mode is TDD.

A.5.1.2.2.3 Test Parameters

The test points to be used in this test are defined in Table A.5.1.2.2.3-1. Details of these test points are available in Annex D with the test points below referenced directly from Table D.1-4.

Table A.5.1.2.2.3-1: FR1 TDD 4RX

TS 38.521-4 Reference	Test num.	Reference channel	Bandwidth (MHz) / Subcarrier spacing (kHz)	Modulation format and code rate	TDD UL-DL pattern	Propagation condition	Correlation matrix and antenna configuration	Reference value		Comment
								Fraction of maximum throughput (%)	SNR (dB)	
5.2.3.2.1_1 4Rx TDD	1-3	R.PDSCH.2-4.1 TDD	40 / 30	256QAM, 0.82	FR1.30-1	TDLA30-10	2x4, ULA Low	70	22.5	Large TBS
5.2.3.2.1_1 4Rx TDD	1-4	R.PDSCH.2-2.1 TDD	40 / 30	16QAM, 0.48	FR1.30-1	TDLC300-100	2x4, ULA Low	30	-0.3	High BLER
5.2.3.2.1_1 4Rx TDD	1-1	R.PDSCH.2-1.1 TDD	40 / 30	QPSK, 0.30	FR1.30-1A	TDLB100-400	2x4, ULA Low	70	-3.1	High channel variation
5.2.3.2.1_1 4Rx TDD	4-1	R.PDSCH.2-2.4 TDD	40 / 30	16QAM, 0.48	FR1.30-1	TDLA30-10	4x4, ULA Low	70	16.4	High throughput Baseline Rx
5.2.3.2.1_1 4Rx TDD	5-1	R.PDSCH.2-2.3 TDD	40 / 30	16QAM, 0.48	FR1.30-1	TDLA30-10	4x4, ULA Medium A	70	23.9	High throughput Enhanced Rx

Other test parameters are defined in TS 38.521-4 [3] Tables 5.2.3.2.1_1.4-1 and 5.2.3.2.1_1.4-2.

A.5.1.2.2.4 Test Description

A.5.1.2.2.4.1 Initial Conditions

Initial conditions are a set of test configurations the UE needs to be tested in and the steps for the SS to take with the UE to reach the correct measurement state. Apply the Initial conditions defined in TS 38.521-4 [3] clause 5.2.3.2.1_1.3.1 with the following additional steps and/or exceptions

- 1.1 Connect an application server to the IP output of the SS.
- 1.2 For an embedded configuration, ensure that the UE has an client test application available. For a tethered configuration, tether the UE to a laptop configured with UDP client software using the appropriate UE to PC interface Modem or Network Interface Connection (NIC) drivers.
5. For NSA case, the E-UTRA anchor is configured as per Annex E. Ensure the UE is in RRC_CONNECTED State (on NR for SA and on E-UTRA for NSA with NR PSCell added). Message contents are as per TS 38.521-4 [3] clause 5.2.3.2.1_1.3.3 and 5.2.3.2.1_1.3.3_2 and Tables 5.2.3.2.1_1.3.3_1-1 through 5.2.3.2.1_1.3.3_1-4.

A.5.1.2.2.4.2 Procedure

1. SS transmits PDSCH via PDCCH DCI format 1_1 for C_RNTI to transmit the DL RMC according to TS 38.521-4 [3] Table 5.2.3.2.1.0-2. The SS sends downlink MAC padding bits on the DL RMC.
2. Set the parameters of the Modulation format and code rate, reference channel, the propagation condition, the correlation matrix and the SNR according to TS 38.521-4 [3] Tables 5.2.3.2.1_1.4-1 and 5.2.3.2.1_1.4-2 as applicable to the test points in Table A.5.1.2.2.3-1.
3. Using UDP data client, begin UDP downlink data transfer from the application server. Wait for 15 seconds and then start recording the UDP throughput result. (This is iteration 1) Continue data transfer for the test duration outlined in Table A.1.1-1. Repeat transfer for iterations [2-3] within the same call as the first iteration.
4. Repeat step 3 for 3 iterations within the same call as the first iteration. Wait for at least 5 seconds between each iteration of the data transfer.
5. Calculate and record the average application layer data throughput across three iterations. Additionally, count and record the overall number of ACK and NACK/DTX on the PUSCH/PUCCH during the test interval purely for information purposes.
6. Record the IP address type (IPv4 or IPv6) used during the UDP data transfers.
7. Using the values in Table 5.4.4-2 (for IPv6) and Table 5.4.4-3 (for IPv4), determine the reduction from PHY reference fractional throughput value listed in Table A.2.1.1.3-1 to obtain reference Application Layer Throughput value.

RADIATED TCP DOWNLINK – STATIC CHANNEL

A.6 5G NR /TCP Downlink Throughput/Radiated/Static Peak Throughput for SA and NSA

A.6.1 5G NR /TCP Downlink Throughput /Radiated/Static Channel Peak Throughput tests for SA and NSA

A.6.1.1 5G NR /UDP Downlink Throughput /Radiated/Static Channel/ SA and NSA (no Downlink Split Bearer)

A.6.1.1.1 Definition

The UE application layer downlink performance for TCP under different static environment is determined by the UE application layer TCP throughput.

A.6.1.1.2 Test Purpose

To measure the performance of the 5G NR UE while downloading TCP based data in a static channel environment for FR2.

A.6.1.1.3 Test Parameters

The common test parameters are defined in 38.101-4 [4] Table 7.5A.1-1. CORESET details are in TS 38.101-4 [4] Table 7.5A.1-2 and MCS indices for indicated UE capabilities are in TS 38.101-4 [4] Table 7.5A.1-3. SNR required to achieve lower layer throughput requirements is specified in TS 38.101-4 [4] Table 7.5A.1-4. The test parameter selection procedure is defined in TS 38.101-4 [4] clause 7.5A.1. In addition, the following test statements from TS 38.521-4 [3] clause 5.5.1.3 apply:

For NSA FR2 case, the E-UTRA anchor is functional link and is setup via the parameters defined in Annex E.

A.6.1.1.4 Test Description

A.6.1.1.4.1 Initial Conditions

Initial conditions are a set of test configurations the UE needs to be tested in and the steps for the SS to take with the UE to reach the correct measurement state. Apply the Initial conditions defined in TS 38.521-4 [3] clause 7.2.2.2.1_1.3.1 with the following additional steps and/or exceptions:

1. In Step 1, no AWGN source needs to be connected as this is a clean channel test case.
 - 1.1 Connect an application server to the IP output of the SS.
 - 1.2 For an embedded configuration, ensure that the UE has an client test application available. For a tethered configuration, tether the UE to a laptop configured with FTP client software using the appropriate UE to PC interface Modem or Network Interface Connection (NIC) drivers.
2. In Step 2 skip reference to TS 38.521-4 [3] 7.2.2.2.1.0-2 since test parameters are already defined for this clean channel test.
3. Step 4 not needed as this is a clean channel/static case.
4. For NSA case, the E-UTRA anchor is configured as per Annex E. Ensure the UE is in RRC_CONNECTED State (NR for SA case and E-UTRA for NSA with NR Pscell added).

A.6.1.1.4.2 Test Procedure

1. Set the UE in a direction found using one of the test procedures defined in Annex H of TS 38.521-4 [3]

2. SS sets the parameters of the bandwidth, MCS and DL reference channel (RMC) according to the test parameter selection procedure defined in TS 38.101-4 [4] clause 7.5A.1. The SS transmits PDSCH via PDCCH DCI format 1_1 for C_RNTI to transmit the DL RMC.
3. SS sends uplink scheduling information for each UL HARQ process via PDCCH DCI format 0_1 for C_RNTI to schedule the UL RMC over PUSCH according to parameters set during initial conditions . The purpose of this scheduling is to accommodate for TCP UL ACK/NACK feedback transmissions.
4. Using the data client, begin TCP downlink data transfer from the application server. Wait for 15 seconds and then start recording the TCP throughput result. (This is iteration 1) Continue data transfer for the test duration outlined in Table A.1-1.
5. Repeat step 3 for 3 iterations within the same call as the first iteration. Wait for at least 5 seconds between each iteration of the data transfer.
6. Calculate and record the average application layer data throughput across three iterations. Additionally, count and record the overall number of ACK and NACK/DTX on the PUSCH/PUCCH during the test interval. Record the IP address type (IPv4 or IPv6) used during the TCP data transfers.
7. Using the values in Table 5.4.4-2 (for IPv6) and Table 5.4.4-3 (for IPv4), determine the reduction from PHY reference fractional throughput value listed in Table A.6.1.1.3-1 to obtain reference Application Layer Throughput value.

RADIATED TCP DOWNLINK – FADING (FRC)

A.7 5G NR /TCP Downlink Throughput /Radiated for Fixed Reference Channel Scenarios (FRC) with Fading

A.7.1 5G NR /TCP Downlink Throughput /Radiated/Fading/FRC

A.7.1.1 5G NR /TCP Downlink Throughput /Radiated/Fading/FRC/2Rx

A.7.1.1.1 5G NR /TCP Downlink Throughput /Radiated/Fading/2Rx TDD/FR2 PDSCH mapping Type A performance - for SA and NSA

Editor's note: Test points 2-2, 2-6 are currently not testable for n260 and n259 pending further optimization of maximum testable SNR in TS 38.521-4

A.7.1.1.1.1 Definition

The UE application layer downlink performance for TCP under different fading environment is determined by the UE application layer TCP throughput.

A.7.1.1.1.2 Test Purpose

To measure the performance of the 5G NR UE while downloading TCP based data in a fading channel environment under 2 receive antenna conditions for FR2.

A.7.1.1.1.3 Test Parameters

The common test parameters are defined in 38.101-4 [4] Table 7.5A.1-1. CORESET details are in TS 38.101-4 [4] Table 7.5A.1-2 and MCS indices for indicated UE capabilities are in TS 38.101-4 [4] Table 7.5A.1-3. SNR required to achieve lower layer throughput requirements is specified in TS 38.101-4 [4] Table 7.5A.1-4. The test parameter selection procedure is defined in TS 38.101-4 [4] clause 7.5A.1. In addition, the following test statements from TS 38.521-4 [3] clause 5.5.1.3 apply:

For NSA FR2 case, the E-UTRA anchor is functional link and is setup via the parameters defined in Annex E.

Test point is detailed in Annex D.2-1.

Table A.7.1.1.1.3-1: FR2 Test Point 2Rx

38.521-4 Reference	Test num.	Reference channel	Bandwidth (MHz)/Subcarrier spacing (kHz)	Modulation format	TDD UL-DL pattern	Propagation condition	Correlation matrix and antenna configuration	Reference value		Comment
								Fraction of maximum throughput (%)	SNR (dB)	
7.2.2.2.1_1	1-2	R.PDSCH .5-2.1 TDD	100/120	16QAM, 0.48	FR2.12 0-1	TDLA30-300	2x2 ULA Low	30	1.7	Exercise HARQ Combining
7.2.2.2.1_1	2-2	R.PDSCH .5-2.2 TDD	100/120	16QAM, 0.48	FR2.12 0-1	TDLA30-300	2x2 ULA Low	70	14.4	High doppler
7.2.2.2.1_1	2-6	R.PDSCH .5-6.1 TDD	100/120	64QAM, 0.43	FR2.12 0-2	TDLA30-75	2x2 ULA Low	70	18.6	Large TBS, Low Doppler

A.7.1.1.1.4 Test Description

A.7.1.1.1.4.1 Initial Conditions

Initial conditions are a set of test configurations the UE needs to be tested in and the steps for the SS to take with the UE to reach the correct measurement state. Apply the Initial conditions defined in TS 38.521-4 [3] clause 7.2.2.2.1_1.3.1 with the following additional steps and/or exceptions:

- 1.1 Connect an application server to the IP output of the SS.
- 1.2 For an embedded configuration, ensure that the UE has an client test application available. For a tethered configuration, tether the UE to a laptop configured with FTP client software using the appropriate UE to PC interface Modem or Network Interface Connection (NIC) drivers.
2. In Step 2 skip reference to TS 38.521-4 [3] 7.2.2.2.1.0-2 since test parameters are already defined for this test.
5. For NSA case, the E-UTRA anchor is configured as per Annex E. Ensure the UE is in RRC_CONNECTED State (NR for SA case and E-UTRA for NSA with NR Pscell added).

A.7.1.1.1.4.2 Procedure

1. Set the UE in a direction found using one of the test procedures defined in Annex H of TS 38.521-4 [3]
2. SS sends uplink scheduling information for each UL HARQ process via PDCCH DCI format 0_1 for C_RNTI to schedule the UL RMC over PUSCH according to parameters set during initial conditions. The purpose of this scheduling is to accommodate for TCP UL ACK/NACK feedback transmissions.
3. Using the data client, begin TCP downlink data transfer from the application server. Wait for 15 seconds and then start recording the TCP throughput result. (This is iteration 1) Continue data transfer for the test duration outlined in Table A.1-1.
4. Repeat step 3 for 3 iterations within the same call as the first iteration. Wait for at least 5 seconds between each iteration of the data transfer.
5. Calculate and record the average application layer data throughput across three iterations. Additionally, count and record the overall number of ACK and NACK/DTX on the PUSCH/PUCCH during the test interval. Record the IP address type (IPv4 or IPv6) used during the TCP data transfers.

6. Using the values in Table 5.4.4-2 (for IPv6) and Table 5.4.4-3 (for IPv4), determine the reduction from PHY reference fractional throughput value listed in Table A.7.1.1.3-1 to obtain reference Application Layer Throughput value.

A.7.1.2 5G NR /TCP Downlink Throughput /Radiated/Fading/FRC/4Rx

A.7.1.2.1 5G NR /TCP Downlink Throughput /Radiated/Fading/FRC/4Rx/FR2 PDSCH mapping Type A performance - 4x4 MIMO

Editor's Note: - Details on fading test points are FFS

- Initial Conditions are incomplete as 4Rx requirements are not defined in 38.521-4

A.7.1.2.1.1 Definition

Same definition as in clause A.7.1.1.1.1.

A.7.1.2.1.2 Test Purpose

To measure the performance of the 5G NR UE while downloading TCP based data in a fading channel environment under 4 receive antenna conditions for FR2.

A.7.1.2.1.3 Test Parameters

The common test parameters are defined in 38.101-4 [4] Table 7.5A.1-1. CORESET details are in TS 38.101-4 [4] Table 7.5A.1-2 and MCS indices for indicated UE capabilities are in TS 38.101-4 [4] Table 7.5A.1-3. SNR required to achieve lower layer throughput requirements is specified in TS 38.101-4 [4] Table 7.5A.1-4. The test parameter selection procedure is defined in TS 38.101-4 [4] clause 7.5A.1. In addition, the following test statements from TS 38.521-4 [3] clause 5.5.1.3 apply:

For NSA FR2 case, the E-UTRA anchor is functional link and is setup via the parameters defined in Annex E.

A.7.1.2.1.4 Test Description

A.7.1.2.1.4.1 Initial Conditions

Initial conditions are a set of test configurations the UE needs to be tested in and the steps for the SS to take with the UE to reach the correct measurement state. Apply the Initial conditions defined in TS 38.521-4 [3] clause [TBD] with the following additional steps and/or exceptions:

- 1.1 Connect an application server to the IP output of the SS.
- 1.2 For an embedded configuration, ensure that the UE has an client test application available. For a tethered configuration, tether the UE to a laptop configured with FTP client software using the appropriate UE to PC interface Modem or Network Interface Connection (NIC) drivers.
2. In Step 2 skip reference to TS 38.521-4 [3] Table [TBD] since test parameters are already defined for this 1 test.
5. For NSA case, the E-UTRA anchor is configured as per Annex E. Ensure the UE is in RRC_CONNECTED State (NR for SA case and E-UTRA for NSA with NR Pscell added).

A.7.1.2.1.4.2 Procedure

Same test procedure as in clause A.7.1.1.1.4.2.

A.8 5G NR /UDP Downlink Throughput/Radiated/Static Peak Throughput for SA and NSA

A.8.1 5G NR /UDP Downlink Throughput /Radiated/Static Channel Peak Throughput tests for SA and NSA

A.8.1.1 5G NR /UDP Downlink Throughput /Radiated/Static Channel/ SA and NSA (no Downlink Split Bearer)

A.8.1.1.1 Definition

The UE application layer downlink performance for UDP under different static environment is determined by the UE application layer UDP throughput.

A.8.1.1.2 Test Purpose

To measure the performance of the 5G NR UE while downloading UDP based data in a static channel environment for FR2.

A.8.1.1.3 Test Parameters

The common test parameters are defined in 38.101-4 [4] Table 7.5A.1-1. CORESET details are in TS 38.101-4 [4] Table 7.5A.1-2 and MCS indices for indicated UE capabilities are in TS 38.101-4 [4] Table 7.5A.1-3. SNR required to achieve lower layer throughput requirements is specified in TS 38.101-4 [4] Table 7.5A.1-4. The test parameter selection procedure is defined in TS 38.101-4 [4] clause 7.5A.1. In addition, the following test statements from TS 38.521-4 [3] clause 5.5.1.3 apply:

For NSA FR2 case, the E-UTRA anchor is functional link and is setup via the parameters defined in Annex E.

A.8.1.1.4 Test Description

A.8.1.1.4.1 Initial Conditions

Initial conditions are a set of test configurations the UE needs to be tested in and the steps for the SS to take with the UE to reach the correct measurement state. Apply the Initial conditions defined in TS 38.521-4 [3] clause 7.2.2.2.1_1.3.1 with the following additional steps and/or exceptions:

1. In Step 1, no AWGN source needs to be connected as this is a clean channel test case.
 - 1.1 Connect an application server to the IP output of the SS.
 - 1.2 For an embedded configuration, ensure that the UE has a client test application available. For a tethered configuration, tether the UE to a laptop configured with FTP client software using the appropriate UE to PC interface Modem or Network Interface Connection (NIC) drivers.
2. In Step 2 skip reference to TS 38.521-4 [3] 7.2.2.2.1.0-2 since test parameters are already defined for this clean channel test.
3. Step 4 not needed as this is a clean channel/static case.
4. For NSA case, the E-UTRA anchor is configured as per Annex E. Ensure the UE is in RRC_CONNECTED State (NR for SA case and E-UTRA for NSA with NR Pscell added).

A.8.1.1.4.2 Test Procedure

1. Set the UE in a direction found using one of the test procedures defined in Annex H of TS 38.521-4 [3]

2. SS sets the parameters of the bandwidth, MCS and DL reference channel (RMC) according to the test parameter selection procedure defined in TS 38.101-4 [4] clause 7.5A.1. The SS transmits PDSCH via PDCCH DCI format 1_1 for C_RNTI to transmit the DL RMC.
3. SS sends uplink scheduling information for each UL HARQ process via PDCCH DCI format 0_1 for C_RNTI to schedule the UL RMC over PUSCH according to parameters set during initial conditions.
4. Using the data client, begin UDP downlink data transfer from the application server. Wait for 15 seconds and then start recording the UDP throughput result. (This is iteration 1) Continue data transfer for the test duration outlined in Table A.1-1.
5. Repeat step 3 for 3 iterations within the same call as the first iteration. Wait for at least 5 seconds between each iteration of the data transfer.
6. Calculate and record the average application layer data throughput across three iterations. Additionally, count and record the overall number of ACK and NACK/DTX on the PUSCH/PUCCH during the test interval. Record the IP address type (IPv4 or IPv6) used during the UDP data transfers.
7. Using the values in Table 5.4.4-2 (for IPv6) and Table 5.4.4-3 (for IPv4), determine the reduction from PHY reference fractional throughput value listed in Table A.6.1.1.3-1 to obtain reference Application Layer Throughput value.

RADIATED UDP DOWNLINK – FADING (FRC)

A.9 5G NR /UDP Downlink Throughput /Radiated for Fixed Reference Channel Scenarios (FRC) with Fading

A.9.1 5G NR /UDP Downlink Throughput /Radiated/Fading/FRC

A.9.1.1 5G NR /UDP Downlink Throughput /Radiated/Fading/FRC/2Rx

A.9.1.1.1 5G NR /UDP Downlink Throughput /Radiated/Fading/2Rx TDD/FR2 PDSCH mapping Type A performance - for SA and NSA

Editor's note: Test points 2-2, 2-6 are currently not testable for n260 and n259 pending further optimization of maximum testable SNR in TS 38.521-4

A.9.1.1.1.1 Definition

The UE application layer downlink performance for UDP under different fading environment is determined by the UE application layer UDP throughput.

A.9.1.1.1.2 Test Purpose

To measure the performance of the 5G NR UE while downloading UDP based data in a fading channel environment under 2 receive antenna conditions for FR2.

A.9.1.1.1.3 Test Parameters

The common test parameters are defined in 38.101-4 [4] Table 7.5A.1-1. CORESET details are in TS 38.101-4 [4] Table 7.5A.1-2 and MCS indices for indicated UE capabilities are in TS 38.101-4 [4] Table 7.5A.1-3. SNR required to achieve lower layer throughput requirements is specified in TS 38.101-4 [4] Table 7.5A.1-4. The test parameter selection procedure is defined in TS 38.101-4 [4] clause 7.5A.1. In addition, the following test statements from TS 38.521-4 [3] clause 5.5.1.3 apply.

For NSA FR2 case, the E-UTRA anchor is functional link and is setup via the parameters defined in Annex E.

Test point is detailed in Annex D.2-1.

Table A.9.1.1.1.3-1: FR2 Test Point 2Rx

38.521-4 Reference	Test num.	Reference channel	Bandwidth (MHz)/Subcar rier spacing (kHz)	Modulati on format	TDD UL-DL pattern	Propagati on condition	Correlatio n matrix and antenna configurati on	Reference value		Comme nt
								Fraction of maximu m through put (%)	SN R (dB)	
7.2.2.2.1 _1	1-2	R.PDSCH .5-2.1 TDD	100/120	16QAM, 0.48	FR2.12 0-1	TDLA30- 300	2x2 ULA Low	30	1.7	Exercise s HARQ Combin ing
7.2.2.2.1 _1	2-2	R.PDSCH .5-2.2 TDD	100/120	16QAM, 0.48	FR2.12 0-1	TDLA30- 300	2x2 ULA Low	70	14. 4	High doppler
7.2.2.2.1 _1	2-6	R.PDSCH .5-6.1 TDD	100/120	64QAM, 0.43	FR2.12 0-2	TDLA30- 75	2x2 ULA Low	70	18. 6	Large TBS, Low Doppler

A.9.1.1.1.4 Test Description

A.9.1.1.1.4.1 Initial Conditions

UDPUDIInitial conditions are a set of test configurations the UE needs to be tested in and the steps for the SS to take with the UE to reach the correct measurement state. Apply the Initial conditions defined in TS 38.521-4 [3] clause 7.2.2.2.1_1.3.1 with the following additional steps and/or exceptions

- 1.1 Connect an application server to the IP output of the SS.
- 1.2 For an embedded configuration, ensure that the UE has an client test application available. For a tethered configuration, tether the UE to a laptop configured with FTP client software using the appropriate UE to PC interface Modem or Network Interface Connection (NIC) drivers.
2. In Step 2 skip reference to TS 38.521-4 [3] 7.2.2.2.1.0-2 since test parameters are already defined for this I test.
3. For NSA case, the E-UTRA anchor is configured as per Annex E. Ensure the UE is in RRC_CONNECTED State (NR for SA case and E-UTRA for NSA with NR Pscell added).

A.9.1.1.1.4.2 Procedure

1. Set the UE in a direction found using one of the test procedures defined in Annex H of TS 38.521-4 [3].
2. SS sets the parameters of the bandwidth, MCS and DL reference channel (RMC) according to the test parameter selection procedure defined in TS 38.101-4 [4] clause 7.5A.1. The SS transmits PDSCH via PDCCH DCI format 1_1 for C_RNTI to transmit the DL RMC.
3. Using the data client, begin UDP downlink data transfer from the application server. Wait for 15 seconds and then start recording the UDP throughput result. (This is iteration 1) Continue data transfer for the test duration outlined in Table A.1-1.
4. Repeat step 3 for 3 iterations within the same call as the first iteration. Wait for at least 5 seconds between each iteration of the data transfer.
5. Calculate and record the average application layer data throughput across three iterations. Additionally, count and record the overall number of ACK and NACK/DTX on the PUSCH/PUCCH during the test interval. Record the IP address type (IPv4 or IPv6) used during the UDP data transfers.

6. Using the values in Table 5.4.4-2 (for IPv6) and Table 5.4.4-3 (for IPv4), determine the reduction from PHY reference fractional throughput value listed in Table A.9.1.1.3-1 to obtain reference Application Layer Throughput value.

A.9.1.2 5G NR /UDP Downlink Throughput /Radiated/Fading/FRC/4Rx

A.9.1.2.1 5G NR /UDP Downlink Throughput /Radiated/Fading/FRC/4Rx/FR2 PDSCH mapping Type A performance - 4x4 MIMO

Editor's Note: - Details on fading test points are FFS

- Initial Conditions are incomplete as 4Rx requirements are not defined in 38.521-4

A.9.1.2.1.1 Definition

Same definition as in clause 9.1.1.1.1.

A.9.1.2.1.2 Test Purpose

To measure the performance of the 5G NR UE while downloading UDP based data in a fading channel environment under 4 receive antenna conditions for FR2.

A.9.1.2.1.3 Test Parameters

The common test parameters are defined in 38.101-4 [4] Table 7.5A.1-1. CORESET details are in TS 38.101-4 [4] Table 7.5A.1-2 and MCS indices for indicated UE capabilities are in TS 38.101-4 [4] Table 7.5A.1-3. SNR required to achieve lower layer throughput requirements is specified in TS 38.101-4 [4] Table 7.5A.1-4. The test parameter selection procedure is defined in TS 38.101-4 [4] clause 7.5A.1. In addition, the following test statements from TS 38.521-4 [3] clause 5.5.1.3 apply.

For NSA FR2 case, the E-UTRA anchor is functional link and is setup via the parameters defined in Annex E.

A.9.1.2.1.4 Test Description

A.9.1.2.1.4.1 Initial Conditions

UDP/Initial conditions are a set of test configurations the UE needs to be tested in and the steps for the SS to take with the UE to reach the correct measurement state. Apply the Initial conditions defined in TS 38.521-4 [3] clause [TBD] with the following additional steps and/or exceptions

- 1.1 Connect an application server to the IP output of the SS.
- 1.2 For an embedded configuration, ensure that the UE has an client test application available. For a tethered configuration, tether the UE to a laptop configured with FTP client software using the appropriate UE to PC interface Modem or Network Interface Connection (NIC) drivers.
2. In Step 2 skip reference to TS 38.521-4 [3] Table [TBD] since test parameters are already defined for this 1 test.
3. For NSA case, the E-UTRA anchor is configured as per Annex E. Ensure the UE is in RRC_CONNECTED State (NR for SA case and E-UTRA for NSA with NR Pscell added).

A.9.1.2.1.4.2 Procedure

Same test procedure as in clause A.9.1.1.4.2.

A.10 5G NR /TCP Downlink Throughput /Conducted for Variable Reference Channel (VRC) Scenarios with Fading for SA and NSA

A.10.1 5G NR /TCP Downlink Throughput /Conducted/Fading/VRC for SA and NSA

A.10.1.1 5G NR /TCP Downlink Throughput /Conducted/Fading/VRC/2Rx for SA and NSA

A.10.1.1.1 5G NR /TCP Downlink Throughput /Conducted/Fading/FRC/2Rx FDD /FR1 PDSCH mapping Type A performance - for SA and NSA

FFS

A.10.1.1.2 5G NR /TCP Downlink Throughput /Conducted/Fading/FRC/2Rx TDD /FR1 PDSCH mapping Type A performance - for SA and NSA

FFS

A.10.1.2 5G NR /TCP Downlink Throughput /Conducted/Fading/FRC/4Rx

A.10.1.2.1 5G NR /TCP Downlink Throughput /Conducted/Fading/VRC/4Rx FDD/FR1 PDSCH mapping Type A performance - for SA and NSA

FFS

A.10.1.2.2 5G NR /TCP Downlink Throughput /Conducted/Fading/VRC/4Rx TDD/FR1 PDSCH mapping Type A performance - for SA and NSA

FFS

CONDUCTED UDP DOWNLINK – FADING (VRC)

A.11 5G NR /UDP Downlink Throughput /Conducted for Variable Reference Channel (VRC) Scenarios for SA and NSA

A.11.1 5G NR /UDP Downlink Throughput /Conducted/Fading/VRC

A.11.1.1 5G NR /UDP Downlink Throughput /Conducted/Fading/VRC/2Rx

A.11.1.1.1 5G NR /UDP Downlink Throughput /Conducted/Fading/VRC/2Rx FDD/FR1 PDSCH mapping Type A performance - for SA and NSA

FFS

A.11.1.1.2 5G NR /UDP Downlink Throughput /Conducted/Fading/VRC/2Rx TDD/FR1
PDSCH mapping Type A performance - for SA and NSA

FFS

A.11.1.2 5G NR /UDP Downlink Throughput /Conducted/Fading/VRC/4Rx

A.11.1.2.1 5G NR /UDP Downlink Throughput /Conducted/Fading/VRC/4Rx FDD/FR1
PDSCH mapping Type A performance - for SA and NSA

FFS

A.11.1.2.2 5G NR /UDP Downlink Throughput /Conducted/Fading/VRC/4Rx FDD/FR1
PDSCH mapping Type A performance - for SA and NSA

FFS

RADIATED TCP DOWNLINK – FADING (VRC)

A.12 5G NR /TCP Downlink Throughput /Radiated for Variable Reference Channel Scenarios (VRC) with Fading

A.12.1 5G NR /TCP Downlink Throughput /Radiated/Fading/VRC

A.12.1.1 5G NR /TCP Downlink Throughput /Radiated/Fading/VRC/2Rx

FFS

A.12.1.2 5G NR /TCP Downlink Throughput /Radiated/Fading/VRC/4Rx

FFS

RADIATED UDP DOWNLINK – FADING (VRC)

A.13 5G NR /UDP Downlink Throughput /Radiated for Variable Reference Channel (VRC) Scenarios

A.13.1 5G NR /UDP Downlink Throughput /Radiated/Fading/VRC

A.13.1.1 5G NR /UDP Downlink Throughput /Radiated/Fading/VRC/2Rx

FFS

A.13.1.2 5G NR /UDP Downlink Throughput /Radiated/Fading/VRC/4Rx

FFS

Annex B: Specific Test Conditions and Environment

FFS

Annex C: Specific Connection Diagrams

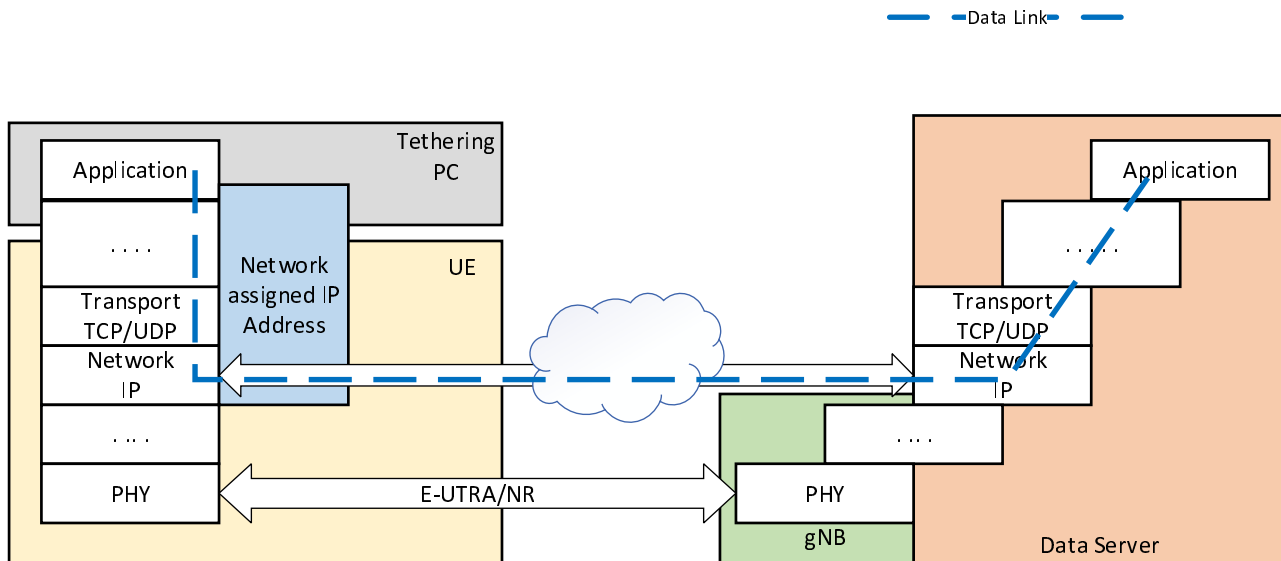

Figure C.1: UE Application Layer Data Throughput Connection Diagram for Tethered

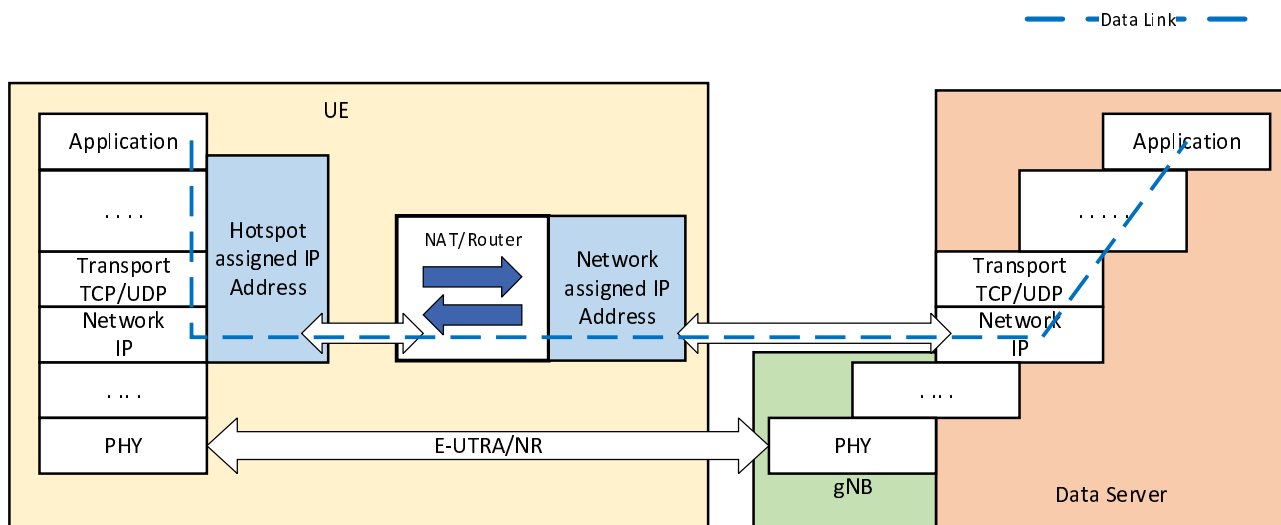

Figure C.2: UE Application Layer Data Throughput Connection Diagram for Embedded

Annex D: Reference Test Points

D.1 FR1 Reference Test Points

Table D.1-1: FR1 FDD 2Rx

TS 38.521-4 Reference	Test num.	Reference channel	Modulation format	Propagation condition	Correlation matrix and antenna configuration	Reference value		Comment
						Fraction of maximum throughput (%)	SNR (dB)	
5.2.2.1.1_1 2Rx FDD	1-3	R.PDSCH.1-4.1 FDD	256AM, 0.82	TDLA30-10	2x2, ULA Low	70	25.6	Large TBS
5.2.2.1.1_1 2Rx FDD	1-4	R.PDSCH.1-2.1 FDD	16QAM, 0.48	TDLC300-100	2x2, ULA Low	30	2	High BLER
5.2.2.1.1_1 2Rx FDD	1-1	R.PDSCH.1-1.1 FDD	QPSK, 0.30	TDLB100-400	2x2, ULA Low	70	0.1	High channel variation
5.2.2.1.1_1 2Rx FDD	2-1	R.PDSCH.1-3.1 FDD	64QAM, 0.51	TDLA30-10	2x2, ULA Low	70	20.4	High throughput Baseline Rx
5.2.2.1.1_2 2Rx FDD	3-1	R.PDSCH.1-2.2 FDD	16QAM, 0.48	TDLA30-10	2x2, ULA Medium	70	18.6	High throughput Enhanced Rx

Table D.1-2: FR1 TDD 2Rx

TS 38.521-4 Reference	Test num.	Reference channel	Bandwidth (MHz) / Subcarrier spacing (kHz)	Modulation format and code rate	TDD UL-DL pattern	Propagation condition	Correlation matrix and antenna configuration	Reference value		Comment
								Fraction of maximum throughput (%)	SNR (dB)	
5.2.2.2.1_1 2Rx TDD	1-3	R.PDSCH.2-4.1 TDD	40 / 30	256QAM, 0.82	FR1.3 0-1	TDLA30-10	2x2, ULA Low	70	26.3	Large TBS
5.2.2.2.1_1 2Rx TDD	1-4	R.PDSCH.2-2.1 TDD	40 / 30	16QAM, 0.48	FR1.3 0-1	TDLC300-100	2x2, ULA Low	30	2.5	High BLER
5.2.2.2.1_1 2Rx TDD	1-1	R.PDSCH.2-1.1 TDD	40 / 30	QPSK, 0.30	FR1.3 0-1A	TDLB100-400	2x2, ULA Low	70	-0.2	High channel variation
5.2.2.2.1_1 2Rx TDD	2-1	R.PDSCH.2-3.1 TDD	40 / 30	64QAM, 0.50	FR1.3 0-1	TDLA30-10	2x2, ULA Low	70	20.8	High throughput Baseline Rx
5.2.2.2.1_2 2Rx TDD	3-1	R.PDSCH.2-2.2 TDD	40 / 30	16QAM, 0.48	FR1.3 0-1	TDLA30-10	2x2, ULA Medium	70	19.0	High throughput Enhanced Rx

Table D.1-3: FR1 FDD 4Rx Test points

TS 38.521-4 Reference	Test num.	Bandwidth (MHz) / Subcarrier spacing (kHz)	Reference channel	Modulation format	Propagation condition	Correlation matrix and antenna configuration	Reference value		Comment
							Fraction of maximum throughput (%)	SNR (dB)	
5.2.3.1.1_1 4Rx FDD	1-3	R.PDSCH.1 -4.1 FDD	10 / 15	256QAM, 0.82	TDLA30-10	2x4, ULA Low	70	22.0	Large TBS
5.2.3.1.1_1 4Rx FDD	1-4	R.PDSCH.1 -2.1 FDD	10 / 15	16QAM, 0.48	TDLC300-100	2x4, ULA Low	30	-0.6	High BLER
5.2.3.1.1_1 4Rx FDD	1-1	R.PDSCH.1 -1.1 FDD	10 / 15	QPSK, 0.30	TDLB100-400	2x4, ULA Low	70	-2.6	High channel variation
5.2.3.1.1_1 4Rx FDD	4-1	R.PDSCH.1 -2.4 FDD	10 / 15	16QAM, 0.48	TDLA30-10	4x4, ULA Low	70	16.6	High throughput Baseline Rx
5.2.3.1.1_1 4Rx FDD	5-1	R.PDSCH.1 -2.3 FDD	10 / 15	16QAM, 0.48	TDLA30-10	4x4, ULA Medium A	70	23.3	High throughput Enhanced Rx

Table D.1-4: FR1 TDD 4Rx

TS 38.521-4 Reference	Test num.	Reference channel	Bandwidth (MHz) / Subcarrier spacing (kHz)	Modulation format and code rate	TDD UL-DL pattern	Propagation condition	Correlation matrix and antenna configuration	Reference value		Comment
								Fraction of maximum throughput (%)	SNR (dB)	
5.2.3.2.1_1 4Rx TDD	1-3	R.PDSCH.2-4.1 TDD	40 / 30	256QAM, 0.82	FR1.30-1	TDLA30-10	2x4, ULA Low	70	22.5	Large TBS
5.2.3.2.1_1 4Rx TDD	1-4	R.PDSCH.2-2.1 TDD	40 / 30	16QAM, 0.48	FR1.30-1	TDLC300-100	2x4, ULA Low	30	-0.3	High BLER
5.2.3.2.1_1 4Rx TDD	1-1	R.PDSCH.2-1.1 TDD	40 / 30	QPSK, 0.30	FR1.30-1A	TDLB100-400	2x4, ULA Low	70	-3.1	High channel variation
5.2.3.2.1_1 4Rx TDD	4-1	R.PDSCH.2-2.4 TDD	40 / 30	16QAM, 0.48	FR1.30-1	TDLA30-10	4x4, ULA Low	70	16.4	High throughput Baseline Rx
5.2.3.2.1_1 4Rx TDD	5-1	R.PDSCH.2-2.3 TDD	40 / 30	16QAM, 0.48	FR1.30-1	TDLA30-10	4x4, ULA Medium A	70	23.9	High throughput Enhanced Rx

Table D.1-5: FR1 Static Channel Test Point

TS 38.521-4 Reference	Reference channel	Bandwidth (MHz) / Subcarrier spacing (kHz)	Modulation format and code rate	TDD UL-DL pattern	Propagation condition	Reference value		Comment
						Fraction of maximum throughput (%)	SNR (dB)	
5.5.1	As per tables in TS 38.521-4 [3] clause 5.5.1.3 and test parameter selection as per TS 38.521-4 [3] 5.5.1.3.1.				Static/ Clean Channel	85	No external noise sources are applied	Peak Throughput

D.2 FR2 Reference Test Points

Table D.2-1: FR2 Test Point 2Rx

38.521-4 Reference	Test num.	Reference channel	Bandwidth (MHz)/Subcarrier spacing (kHz)	Modulation format	TDD UL-DL pattern	Propagation condition	Correlation matrix and antenna configuration	Reference value		Comment
								Fraction of maximum throughput (%)	SNR (dB)	
7.2.2.2.1_1	1-2	R.PDSCH.5-2.1 TDD	100/120	16QAM, 0.48	FR2.120-1	TDLA30-300	2x2 ULA Low	30	1.7	Exercises HARQ Combining
7.2.2.2.1_1	2-2	R.PDSCH.5-2.2 TDD	100/120	16QAM, 0.48	FR2.120-1	TDLA30-300	2x2 ULA Low	70	14.4	High doppler
7.2.2.2.1_1	2-6	R.PDSCH.5-6.1 TDD	100/120	64QAM, 0.43	FR2.120-2	TDLA30-75	2x2 ULA Low	70	18.6	Large TBS, Low Doppler

Annex E: E-UTRA Anchor Configuration for NSA testing Diagrams

The clauses within Annex D of TS 38.521-4 [3] define the E-UTRA link setup config for NSA performance tests and shall be used for all E-UTRA anchor for NSA tests defined within Annex A.2, unless otherwise specified within the test case.

Editor's Note: The following aspects are either missing or not yet determined:

- This clause is currently leveraged from TR 37.901. Further study will determine if any aspect has to be changed.
- It is for further study to determine if any additional items are required to be provisioned prior to command interface establishment.
- The command set and test parameters that are needed for automation of embedded data throughput performance in TR 37.901 are missing.
- The fields required to support result reporting are missing.

Annex F: Embedded Data Client Recommendations

F.1 Purpose of annex

This annex identifies the recommendations and details concerning a common application interface to allow for automation of testing for the UE Application Layer Data Throughput Performance test procedures that utilize an embedded data client.

F.2 Embedded Data Client Automation

F.2.1 Embedded Data Client Functionality

The following functionality is recommended for the embedded data client to support automation.

- The application may start automatically on device power-up or reset. If the application does not support this feature, the operator manually starts the application at the beginning of the test campaign.
- The application automatically sets up a data call using the expected radio bearer that is used for test and establishes a connection to the test server.
- The application may periodically poll the test server with the Poll for Task command when not actively performing a task to determine if the test server has a new task.
- The application will be informed by the test server about the task list to be performed either in response to the Poll for Task command or via a command that is pushed to the application from the test server.
- The application should not send, or limits as much as possible, any commands, responses and status updates during a measurement unless the time-out period has expired so that the UE application layer data throughput results are not impacted. If the application does send limited updates, the downlink and uplink performance loss should be declared in the test results and should not exceed 0.4 kbps.
- The application should listen for commands at all times so that the test server can interrupt the measurement.

F.2.2 Embedded Data Client Provisioning

The embedded data client may provide a mechanism to provision common parameters required for interfacing with test systems. The following captures aspects that should be considered if the application provides for such provisioning.

- Provisioning of the data client does not need to be automated.
- A manual interface or parameter file approach could be used. Instructions for operation should be provided.
- The items expected to be provisioned prior to command interface establishment are as follows:
 - IP address and port number, if necessary, for the test server
 - Poll for Task Command Polling Period (if the polling approach is used, this may be a configurable item or a hardcoded value)
 - FFS

If certain parameters are hard-coded, these parameters should be documented to allow for the test systems to be properly configured.

F.2.3 Embedded Data Client Command Set and Operation

The embedded data client should use the specified command set and follow the operational structure defined in this clause.

F.2.3.1 Poll for Task Command

The embedded data client application may make use of a polling mechanism to query the test server for tasks to perform. If polling is used, the following instructions apply.

The Poll for Task command shall be substantiated with FFS.

If there is no task for the application to perform, an FFS error is returned. The application shall start its Waiting for Task Polling Period timer. When the timer expires, another Poll for Task command shall be sent.

If there is a task for the application to perform, the test server may return an FFS.

F.2.3.2 Task List

The test server will deliver a task list to the application. The task list will be delivered over the IP connection using HTTP(S) or raw TCP. The task list can contain multiple tasks that are listed sequentially for the application to execute or can also contain a single task. The format for the task list is XML for ASCII text string.

For each task, the following lists the valid parameters and valid strings for each parameter. The list of items should be considered as logical representations of the required parameters and content. The actual syntax may vary. The instructions for the application should provide the recommended usage for each particular test type.

- FFS

If the requested task list is unknown to the application, the application may ignore it or return an error of FFS. The application will then go back to a waiting for command state.

F.2.3.3 Result Reporting

Upon completion of the specified test sequence, the application shall upload the test results to the test server over the IP connection using HTTP(S) POST or raw TCP.

The result files shall be in CSV or XML format.

Annex G: Applicability

This clause adds appropriate applicability references to TS 38.521-4 [3].

For FR1 testing: The applicability requirements for different number of RX antenna ports shall follow the principles defined in TS 38.521-4 [3] clauses 5.1.1.2, 5.1.1.3 and 5.1.1.4. For FR2 testing: The applicability requirements for different number of RX antenna ports shall follow the principles defined in TS 38.521-4 [3] clauses 7.1.1.2, 7.1.1.3 and 7.1.1.4.

For Interworking scenarios testing the guidance from TS 38.521-4 [3] clause 9.1.1.1 applies.

Annex H: Change history

Change history							
Date	TSG #	TSG Doc.	CR	R e v	Subject/Comment	Old	New
2019-08	RAN5#84	R5-197487	6898	-	Initial draft created	-	0.1.0
2019-08	RAN5#84	R5-197482	-	-	TP for TR 37.901-5 on Definition of 5G NR UE Application Layer Data	-	0.1.0
2019-08	RAN5#84	R5-197484	-	-	TP for TR 37.901-5 on Transport and Application Layer Protocols	-	0.1.0
2019-08	RAN5#84	R5-196905	-	-	TP for TR 37.901-5 on Parameters for Measurement	-	0.1.0
2019-08	RAN5#84	R5-197483	-	-	TP for TR 37.901-5 on Test Configurations	-	0.1.0
2019-08	RAN5#84	R5-197484	-	-	TP for TR 37.901-5 on Transport and Application Layer Protocols	-	0.1.0
2019-08	RAN5#84	R5-196908	-	-	TP for TR 37.901-5 on Test Environment	-	0.1.0
2019-08	RAN5#84	R5-197485	-	-	TP for TR 37.901-5 on Data Transfer Scenarios	-	0.1.0
2019-08	RAN5#84	R5-196910	-	-	TP for TR 37.901-5 on Test Procedure Structure and Content for App Tput measurements	-	0.1.0
2019-08	RAN5#84	R5-196911	-	-	TP for TR 37.901-5 on Test System Uncertainty and Test Tolerance	-	0.1.0
2019-11	RAN5#85	R5-199537	-	-	TP to TR 37.901-5 to introduce test points within test cases in Annex A	0.1.0	0.2.0
2019-11	RAN5#85	R5-199538	-	-	Text Proposal for Section 5.7 - Statistical Analysis	0.1.0	0.2.0
2019-11	RAN5#85	R5-199539	-	-	Text Proposal to update TC A.2.1.1	0.1.0	0.2.0
2019-11	RAN5#85	R5-199429	-	-	Text Proposal to add TC A.3.1.2.1	0.1.0	0.2.0
2019-11	RAN5#85	R5-199540	-	-	Text Proposal to add TC A.4.1.1	0.1.0	0.2.0
2019-11	RAN5#85	R5-199430	-	-	Text Proposal to add TC A.6.1	0.1.0	0.2.0
2019-11	RAN5#85	R5-199431	-	-	Text Proposal to add TC A.7.1.1.1	0.1.0	0.2.0
2019-11	RAN5#85	R5-199432	-	-	Text Proposal to add TC A.9.1.1.1	0.1.0	0.2.0
2019-11	RAN5#85	R5-199541	-	-	Text Proposal to update Upper Layer Parameters	0.1.0	0.2.0
2019-11	RAN5#85	R5-199542	-	-	Text Proposal to study and update Application Throughput Details	0.1.0	0.2.0
2020-03	RAN5#86	R5-200781	-	-	Text Proposal to add TC A.2.1.2	1.0.0	1.1.0
2020-03	RAN5#86	R5-200782	-	-	Text Proposal to add TC A.4.1.2	1.0.0	1.1.0
2020-03	RAN5#86	R5-200783	-	-	Text Proposal to update TC A.7.1.1.1	1.0.0	1.1.0
2020-03	RAN5#86	R5-200784	-	-	Text Proposal to update TC A.9.1.1.1	1.0.0	1.1.0
2020-03	RAN5#86	R5-200789	-	-	Text Proposal to add TC A.3.1.1.1	1.0.0	1.1.0
2020-03	RAN5#86	R5-200802	-	-	Text Proposal to add TC A.3.1.1.2	1.0.0	1.1.0
2020-03	RAN5#86	R5-200817	-	-	Text Proposal to add TC A.3.1.2.2	1.0.0	1.1.0
2020-03	RAN5#86	R5-200855	-	-	Text Proposal to add TC A.5.1.1.1	1.0.0	1.1.0
2020-03	RAN5#86	R5-200860	-	-	Text Proposal to add TC A.5.1.1.2	1.0.0	1.1.0
2020-03	RAN5#86	R5-200865	-	-	Text Proposal to add TC A.5.1.2.1	1.0.0	1.1.0
2020-03	RAN5#86	R5-200870	-	-	Text Proposal to add TC A.5.1.2.2	1.0.0	1.1.0
2020-06	RAN5#87	R5-202053	-	-	Text proposal to add A.8.1.1	1.1.0	1.2.0
2020-06	RAN5#87	R5-202469	-	-	Text Proposal to update Clause 5.5 - Test Environment	1.1.0	1.2.0
2020-06	RAN5#87	R5-202470	-	-	Text Proposal to update Clause 5.9 - Test Tolerances	1.1.0	1.2.0
2020-06	RAN5#87	R5-202861	-	-	Text Proposal to update VRC based App tput sections in TR 37.901-5	1.1.0	1.2.0
2020-06	RAN5#87	R5-202472	-	-	Text Proposal to update TC A.7.1.1.1	1.1.0	1.2.0
2020-06	RAN5#87	R5-202473	-	-	Text Proposal to update TC A.9.1.1.1	1.1.0	1.2.0
2020-06	RAN5#87	R5-202474	-	-	Text Proposal to update TC A.8.1	1.1.0	1.2.0
2020-06	RAN#88	RP-201142	-	-	Presented to RAN#88 plenary for approval	2.0.0	2.0.0
2020-06	RAN5#87	-	-	-	Raised to v16.0.0 with editorial changes only	2.0.0	16.0.0
2020-09	RAN5#88	R5-204318	0001	-	Text Proposal to update Clause 5.5 - Test Environment	16.0.0	16.1.0
2020-09	RAN5#88	R5-204894	0002	1	Text Proposal to update TC A.7.1.1.1	16.0.0	16.1.0
2020-09	RAN5#88	R5-204895	0003	1	Text Proposal to update TC A.9.1.1.1	16.0.0	16.1.0
2020-12	RAN5#89	R5-206730	0007	1	Editorial updates to Annex in TR 37.901-5	16.1.0	16.2.0
2020-12	RAN5#89	R5-206795	0005	1	Corrections to the test procedures for Application Layer Data Throughput	16.1.0	16.2.0
2020-12	RAN5#89	R5-206796	0006	1	Corrections across TR 37.901-5	16.1.0	16.2.0
2021-03	RAN5#90	R5-210593	0008	-	Updates to 37.901-5 Annex A for Downlink Throughput tests with Fading and FRC scenario	16.2.0	16.3.0
2021-03	RAN5#90	R5-210594	0009	-	Updates to connection diagram for Application Layer Data Throughput	16.2.0	16.3.0
2021-03	RAN5#90	R5-210597	0012	-	Updates to Conclusion for Application Layer Data Throughput	16.2.0	16.3.0
2021-03	RAN5#90	R5-211782	0010	1	Updates to Impact of Modem Performance in Application Layer Throughput	16.2.0	16.3.0
2021-06	RAN5#91	R5-214097	0013	1	Updates to 37.901-5 Annex A for Downlink Throughput tests with Fading and FRC scenario	16.3.0	16.4.0

History

Document history		
V16.1.0	November 2020	Publication
V16.2.0	January 2021	Publication
V16.3.0	April 2021	Publication
V16.4.0	August 2021	Publication