



**Digital cellular telecommunications system (Phase 2+);  
Universal Mobile Telecommunications System (UMTS);  
LTE;  
Identity management and 3GPP security interworking;  
Identity management and  
Generic Authentication Architecture (GAA) interworking  
(3GPP TR 33.924 version 12.0.0 Release 12)**



---

**Reference**

RTR/TSGS-0333924vc00

---

**Keywords**

GSM,LTE,SECURITY,UMTS

**ETSI**

---

650 Route des Lucioles  
F-06921 Sophia Antipolis Cedex - FRANCE

Tel.: +33 4 92 94 42 00 Fax: +33 4 93 65 47 16

Siret N° 348 623 562 00017 - NAF 742 C  
Association à but non lucratif enregistrée à la  
Sous-Préfecture de Grasse (06) N° 7803/88

---

**Important notice**

The present document can be downloaded from:

<http://www.etsi.org>

The present document may be made available in electronic versions and/or in print. The content of any electronic and/or print versions of the present document shall not be modified without the prior written authorization of ETSI. In case of any existing or perceived difference in contents between such versions and/or in print, the only prevailing document is the print of the Portable Document Format (PDF) version kept on a specific network drive within ETSI Secretariat.

Users of the present document should be aware that the document may be subject to revision or change of status. Information on the current status of this and other ETSI documents is available at

<http://portal.etsi.org/tb/status/status.asp>

If you find errors in the present document, please send your comment to one of the following services:

[http://portal.etsi.org/chaircor/ETSI\\_support.asp](http://portal.etsi.org/chaircor/ETSI_support.asp)

---

**Copyright Notification**

No part may be reproduced or utilized in any form or by any means, electronic or mechanical, including photocopying and microfilm except as authorized by written permission of ETSI.

The content of the PDF version shall not be modified without the written authorization of ETSI.

The copyright and the foregoing restriction extend to reproduction in all media.

© European Telecommunications Standards Institute 2014.

All rights reserved.

**DECT™**, **PLUGTESTS™**, **UMTS™** and the ETSI logo are Trade Marks of ETSI registered for the benefit of its Members. **3GPP™** and **LTE™** are Trade Marks of ETSI registered for the benefit of its Members and of the 3GPP Organizational Partners.

**GSM®** and the GSM logo are Trade Marks registered and owned by the GSM Association.

---

## Intellectual Property Rights

IPRs essential or potentially essential to the present document may have been declared to ETSI. The information pertaining to these essential IPRs, if any, is publicly available for **ETSI members and non-members**, and can be found in ETSI SR 000 314: *"Intellectual Property Rights (IPRs); Essential, or potentially Essential, IPRs notified to ETSI in respect of ETSI standards"*, which is available from the ETSI Secretariat. Latest updates are available on the ETSI Web server (<http://ipr.etsi.org>).

Pursuant to the ETSI IPR Policy, no investigation, including IPR searches, has been carried out by ETSI. No guarantee can be given as to the existence of other IPRs not referenced in ETSI SR 000 314 (or the updates on the ETSI Web server) which are, or may be, or may become, essential to the present document.

---

## Foreword

This Technical Report (TR) has been produced by ETSI 3rd Generation Partnership Project (3GPP).

The present document may refer to technical specifications or reports using their 3GPP identities, UMTS identities or GSM identities. These should be interpreted as being references to the corresponding ETSI deliverables.

The cross reference between GSM, UMTS, 3GPP and ETSI identities can be found under <http://webapp.etsi.org/key/queryform.asp>.

---

## Modal verbs terminology

In the present document "**shall**", "**shall not**", "**should**", "**should not**", "**may**", "**may not**", "**need**", "**need not**", "**will**", "**will not**", "**can**" and "**cannot**" are to be interpreted as described in clause 3.2 of the [ETSI Drafting Rules](#) (Verbal forms for the expression of provisions).

"**must**" and "**must not**" are **NOT** allowed in ETSI deliverables except when used in direct citation.

---

# Contents

Intellectual Property Rights .....	2
Foreword.....	2
Modal verbs terminology.....	2
Foreword.....	4
Introduction .....	4
1 Scope .....	5
2 References .....	5
3 Definitions, symbols and abbreviations .....	6
3.1 Definitions .....	6
3.2 Abbreviations .....	6
4 Interworking of OpenID and GAA .....	7
4.1 Introduction .....	7
4.2 Architectural Descriptions.....	7
4.2.1 Generic Bootstrapping Architecture .....	7
4.2.2 OpenID Architecture.....	9
4.3 NAF and OpenID-IdP Co-location.....	10
4.4 Message Flow for Interworking Scenario .....	11
4.4.1 Message Flow for direct GBA Interworking Scenario.....	11
4.4.2 Message Flow for Split Terminal GBA Interworking Scenario .....	13
4.4.2.1 General	13
4.4.2.2 Differentiating between Scenarios .....	14
4.4.2.3 Scenarios not using cryptographic binding .....	14
4.4.2.4 Scenarios using cryptographic binding .....	23
4.5 Mapping of Concepts .....	33
4.5.1 Identifiers in OpenID and GBA.....	33
4.5.2 Association Session Concept.....	35
4.5.3 Assertions .....	35
4.5.3.1 Positive Assertions .....	35
4.5.3.2 Negative Assertions .....	35
4.6 Use of GUSS and USS for OpenID.....	36
<b>Annex A (informative): Example for Charging via IdP.....</b>	<b>37</b>
<b>Annex B: Change history .....</b>	<b>40</b>
History .....	41

---

## Foreword

This Technical Report has been produced by the 3<sup>rd</sup> Generation Partnership Project (3GPP).

The contents of the present document are subject to continuing work within the TSG and may change following formal TSG approval. Should the TSG modify the contents of the present document, it will be re-released by the TSG with an identifying change of release date and an increase in version number as follows:

Version x.y.z

where:

- x the first digit:
  - 1 presented to TSG for information;
  - 2 presented to TSG for approval;
  - 3 or greater indicates TSG approved document under change control.
- y the second digit is incremented for all changes of substance, i.e. technical enhancements, corrections, updates, etc.
- z the third digit is incremented when editorial only changes have been incorporated in the document.

---

## Introduction

3GPP SA3 outlined the interworking of the operator controlled GBA with the Liberty Alliance Identity Management. This was sufficient for the time of writing, but now new additional systems are deployed and used. If we want to enable interworking of operator centric identity management, then smooth interworking with those new systems need to be outlined. If this is not done, then a seamless interworking is not possible on global scale and it would be difficult to leverage the existing customer base and security level that operators have.

---

# 1 Scope

The objective is to extend the current identity management as outlined in TS 33.220, TS 33.222, TS 29.109 and TR 33.980 with the latest developments on identity management outside of the 3GPP sphere. This will allow a better integration and usage of identity management for services in 3GPP and seamless integration with existing services that are not standardized in 3GPP. This report outlines the interworking of GBA and OpenID.

---

# 2 References

The following documents contain provisions which, through reference in this text, constitute provisions of the present document.

- References are either specific (identified by date of publication, edition number, version number, etc.) or non-specific.
- For a specific reference, subsequent revisions do not apply.
- For a non-specific reference, the latest version applies. In the case of a reference to a 3GPP document (including a GSM document), a non-specific reference implicitly refers to the latest version of that document *in the same Release as the present document*.

- [1] 3GPP TR 21.905: "Vocabulary for 3GPP Specifications".
- [2] 3GPP TS 33.220: "Generic Authentication Architecture (GAA); Generic Bootstrapping Architecture".
- [3] 3GPP TS 24.109: "Bootstrapping Interface (Ub) and Network Application Function Interface (Ua); Protocol Details".
- [4] 3GPP TR 33.980: "Interworking of Liberty Alliance Identity Federation Framework (ID-FF), Identity Web Service Framework (ID-WSF) and the Generic Authentication Architecture (GAA)".
- [5] 3GPP TS 33.222: "Generic Authentication Architecture (GAA); Access to network application functions using Hypertext Transfer Protocol over Transport Layer Security (HTTPS)".
- [6] 3GPP TS 33.223: "Generic Bootstrapping Architecture (GBA) Push Function".
- [7] 3GPP TS 29.109: "Generic Authentication Architecture (GAA); Zh and Zn Interfaces based on the Diameter Protocol; Stage 3".
- [8] OpenID Foundation "OpenID Authentication 2.0", <http://openid.net/>.
- [9] OpenID Foundation "OpenID Attribute Exchange 1.0", <http://openid.net/>.
- [10] OpenID Foundation "OpenID Provider Authentication Policy Extension 1.0", <http://openid.net/>.
- [11] OASIS Reed, D.; McAlpin, D.: "Extensible Resource Identifier (XRI) Syntax v2.0"; <http://www.oasis-open.org/>
- [12] OpenID Foundation, <http://openid.net/foundation/>
- [13] OpenID Site Directory, <http://openiddirectory.com/>
- [14] 3GPP TS 33.259: "Key Establishment between a UICC hosting device and a remote device".
- [15] IETF RFC 4006, "Diameter Credit Control", <http://tools.ietf.org/html/rfc4006>
- [16] W3C, "HTML 4.01 Specification", <http://www.w3.org/TR/html401/>
- [17] IETF RFC 2617 (1999): "HTTP Authentication: Basic and Digest Access Authentication".

- [18] IETF RFC 3761 (2004): "The E.164 to Uniform Resource Identifiers (URI) Dynamic Delegation Discovery System (DDDS) Application (ENUM)".

---

## 3 Definitions, symbols and abbreviations

### 3.1 Definitions

For the purposes of the present document, the terms and definitions given in TR 21.905 [1] and the following apply. A term defined in the present document takes precedence over the definition of the same term, if any, in TR 21.905 [1]. The GAA / GBA specific definitions are originated from [2] and the OpenID definitions are originated from [8]. In case of conflict [2] and [8] take precedence.

**Attribute:** An attribute is used in the OpenID Attribute Exchange service extension [9]. This extension provides a mechanism for moving identity related information between sites. An attribute is associated with a Subject Identifier. An attribute has a type identifier and a value. An attribute type identifier is a URI. An attribute value can be any kind of data.

**Bootstrapping Server Function (BSF):** A Bootstrapping Server Function (BSF) is hosted in a network element under the control of an MNO. BSF, HSS/HLR, and UEs participate in GBA in which a shared secret is established between the network and a UE by running a bootstrapping procedure. The shared secret can be used between NAFs and UEs, for example, for authentication purposes.

**GBA User Security Settings:** GUSS contains the BSF specific information element and the set of all application-specific USSs.

**Identifier:** An Identifier in OpenID is either an "http" or "https" URL, or an XRI [11]. OpenID [8] defines various kinds of identifiers depending on the context.

**Network Application Function (NAF):** A NAF is hosted in a network element. GBA may be used between NAFs and UEs for authentication purposes, and for securing the communication path between the UE and the NAF.

**OpenID Provider (OP):** An OpenID Provider (OP) is an OpenID Authentication Server on which a Relying Party relies for an assertion that the end user controls an Identifier.

**OpenID Provider driven identifier selection:** OpenID Provider driven identifier selection is the ability for a user to enter the URL of their OpenID Provider into an OpenID field rather than their personal OpenID URL. This allows the web site (RP) to start the OpenID authentication flow and send the user over to the correct OpenID provider. The user can then authenticate to the OpenID provider, select a particular OpenID URL and persona if they have multiple. This will result in an actual user OpenID URL or an anonymous OpenID URL being returned to the RP.

**OP Endpoint URL:** The URL which accepts OpenID Authentication protocol messages, obtained by performing discovery on the User-Supplied identifier. This value must be an absolute HTTP or HTTPS URL.

**Relying Party (RP):** A Relying Party is a web application that wants a proof that the end user controls an Identifier.

**User Supplied Identifier:** An Identifier that was presented by the end user to the RP, or selected by the user at the OpenID Provider. During the initiation phase of the protocol, an end user may enter either their own Identifier or an OP Identifier. If an OP Identifier is used, the OP may then assist the end user in selecting an Identifier to share with the RP.

### 3.2 Abbreviations

For the purposes of the present document, the abbreviations given in TR 21.905 [1] and the following apply. An abbreviation defined in the present document takes precedence over the definition of the same abbreviation, if any, in TR 21.905 [1].

AKA	Authentication and Key Agreement Protocol
AV	Authentication Vector
BSF	Bootstrapping Server Function
IdP	Identity Provider
GAA	Generic Authentication Architecture

GBA	Generic Bootstrapping Architecture
GPI	GBA Push Information
GUSS	GBA User Security Settings
HLR	Home Location Register
HSS	Home Subscriber Server
ME	Mobile Equipment
MNO	Mobile Network Operator
NAF	Network Application Function
OP	OpenID Provider
PAPE	Provider Authentication Policy Extension
RP	Relying Party
SLF	Subscriber Locator Function
SP	Service Provider
UE	User Equipment
USS	User Security Settings

---

## 4 Interworking of OpenID and GAA

### 4.1 Introduction

In this chapter we outline how the Generic Authentication Architecture, in particular, the Generic Bootstrapping Architecture (GBA) as specified in [2] can be utilized by the OpenID protocol as specified by [8]. The focus will lie on the impact to the network nodes of the Mobile Network Operator (MNO) and the service providers, the supported protocols and the message flows.

The general setting for the GBA – OpenID interworking is quite similar to the GBA – Liberty Alliance Interworking as outlined in [4]. The major difference is that OpenID as currently specified is more lightweight than the Liberty Alliance Web Service and Identity Federation Framework and therefore many well-known service providers have chosen OpenID for their identity management solution.

### 4.2 Architectural Descriptions

#### 4.2.1 Generic Bootstrapping Architecture

In this section, we give a brief overview of the Generic Bootstrapping Architecture as described in TS 33.220 [2]. GBA enables automatic provisioning of shared keys between a User Equipment (UE) and an application server (Network Application Function (NAF)). The Home Subscriber Server (HSS) contains the long-term subscriber key. The Bootstrapping Server Function (BSF) is a GBA specific network function that resides in the home MNO of the user. It facilitates the use of AKA to bootstrap a new GBA master session key named Ks. The Subscriber Locator Function (SLF) is queried by the BSF in conjunction with the Zh interface operation to get the name of the HSS containing the required subscriber specific data.



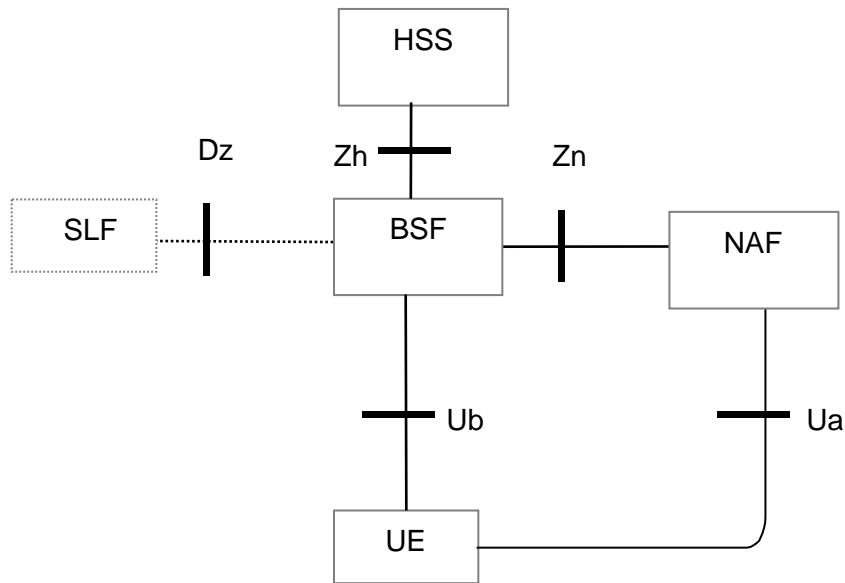

**Figure 4.2.1 Simple Network Architecture for GBA**

The basic message flow is as follows (for all details, parameter, formats, key derivation and error cases see [2] TS 33.220 section 4.5.2, which takes also precedence in case of conflict).

1. The UE sends a bootstrapping HTTP request towards the BSF over Ub reference point. The User-Supplied Identifier may be an OP Identifier, which allows the use of OpenID Provider driven identifier selection.
2. The BSF determines the IMPI based on the request. If there are several HSS the BSF may consult the SLF to determine the name of the correct HSS for this user.

The BSF retrieves the complete set of GBA user security settings (GUSS) and one Authentication Vector AV over the reference point Zh from the HSS. The BSF might use a local copy of the GUSS (for details see [2]).

The GUSS is optional to support in [2], but if GBA\_U is intended to be used by the NAF, then the GUSS must be used.

In the case that no HSS with Zh reference point is deployed, the BSF retrieves the Authentication Vector over the reference point Zh' from either an HLR or an HSS with Zh' reference point support.

3. Then BSF forwards the RAND and AUTN to the UE in the 401 message. This is to demand the UE to authenticate itself.
4. The UE checks AUTN to verify that the challenge is from an authorised network; the UE also calculates CK, IK and RES. This will result in session keys IK and CK in UE.
5. The UE sends another HTTP request, containing the Digest AKA response (calculated using RES), to the BSF.
6. The BSF authenticates the UE by verifying the Digest AKA response.
7. The BSF generates the master key material Ks by concatenating CK and IK. The BSF generates also the application specific keys Ks\_(ext/int)\_NAF. The bootstrapping transaction identifier B-TID value shall be also generated.
8. The BSF shall send a 200 OK message, including a B-TID, to the UE to indicate the success of the authentication. In addition, in the 200 OK message, the BSF shall supply the lifetime of the key Ks. The key material Ks is generated in UE.
9. Both the UE and the BSF shall use the Ks to derive the application specific key material Ks\_NAF during the procedures as specified in clause 4.5.3 of [2]. Ks\_NAF shall be used for securing the reference point Ua, in our case the authentication to the OP. If GBA\_U is used, then the Ks\_ext\_NAF should be used for securing the Ua reference point.

The UE and the BSF shall store the key Ks with the associated B-TID for further use, until the lifetime of Ks has expired, or until the key Ks is updated or until the deletion conditions are satisfied (see 4.4.11 in [2]).

GBA is used by many services like MBMS (Multimedia Broadcast Multicast Service), Enhanced MBMS, Access Network Discovery and Service Function (ANDSF), Open Mobile Alliance (OMA) XML Document Management, Presence Security etc. GBA can use USIM with GBA\_U aware UICC application, ISIM or SIM cards. GBA and OpenID are independent of each other and the message flow above is given to introduce how GBA works and to ease the understanding for the interworking.

## 4.2.2 OpenID Architecture

The OpenID protocol [9] is specified by the OpenID Foundation [12]. It utilizes URL based Identifier.

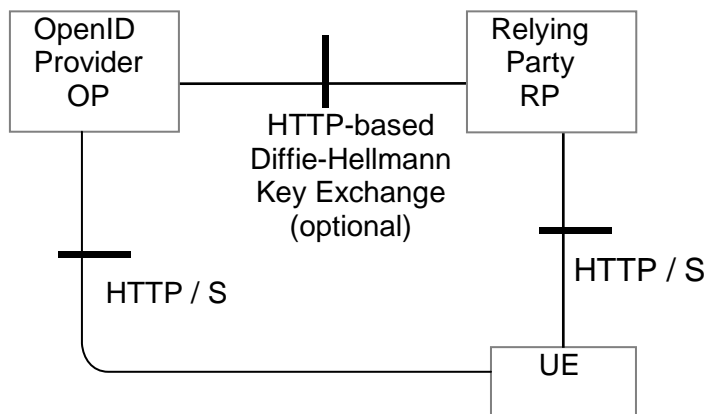

**Figure 4.2.2 Simple OpenID Network Architecture**

OpenID is HTTP POST and REPLY based. The basic message flow is as follows (for details and message parameters see OpenID Authentication 2.0 [8], which also takes precedence in case of conflict):

To initiate OpenID Authentication, the Relying Party should present the end user with a form that has a field for entering a User-Supplied Identifier. The form field's "name" attribute should have the value "openid\_identifier".

1. The browser in the UE sends a User-Supplied Identifier to the Relying Party.
2. The User-Supplied Identifier is normalized as described in Appendix A1 of [8]. The RP retrieves the address of the OP and performs a discovery of the OP Endpoint URL (based on the User-Supplied Identifier) that the end user wishes to use for authentication.
3. The RP and the OP may then establish a shared secret (called association) using the Diffie-Hellman Key Exchange Protocol [8]. The purpose of this shared secret is that the OP may sign subsequent messages and the RP can verify those messages.

NOTE1: This association is an optional feature in [8] and not required for interworking purposes.

4. The RP redirects the UE's browser to the OP with an OpenID Authentication Request as defined in [8].
5. The OP establishes whether the end user is authorized to perform OpenID Authentication and wishes to do so.

NOTE2: [8] does not specify the manner and protocol used for authentication. In clause 4.4 we will outline how GBA based authentication using TS 33.222 [5] fits in here.

6. The OP redirects the UE's browser back to the RP with either an assertion that authentication is approved or a message that authentication failed.
7. The RP verifies the information received from the OP. The user is now authenticated.

NOTE3: This Technical Report describes the interworking with OpenID version 2.0. If OpenID Authentication version 1.0 is used, then it should be noted that this specification was quickly replaced by OpenID Authentication version 1.1. OpenID version 1.1 made it clearer what was mandatory and what was optional to support. OpenID Authentication version 2.0 was a larger step forward. It allows usage of XRI to discover the OP, which was not possible in OpenID Authentication version 1.1. It has been reported that some OpenID Authentication version 1.1 implementations support XRIs. OpenID Authentication version 2.0 mandates the usage of the opened.ns field in the HTTP requests. If the value is absent or set to "http://openid.net/signon/1.1" or "http://openid.net/signon/1.0" instead of "http://specs.openid.net/auth/2.0", then the message should be interpreted using OpenID Authentication 1.1 Compatibility mode.

### 4.3 NAF and OpenID-IdP Co-location

The straightforward approach to combine the GBA and the OpenID Architectures is to co-locate the NAF functionality with the OP. The NAF functionality may be added in form of a library to the OpenID server.

NOTE: Other co-location approaches may require that the OP server has to support Diameter based reference point. The OPs as today are not telecommunication network nodes and hence it can not be assumed that they support the Diameter and underlying protocols just for the purpose of interworking with GBA.

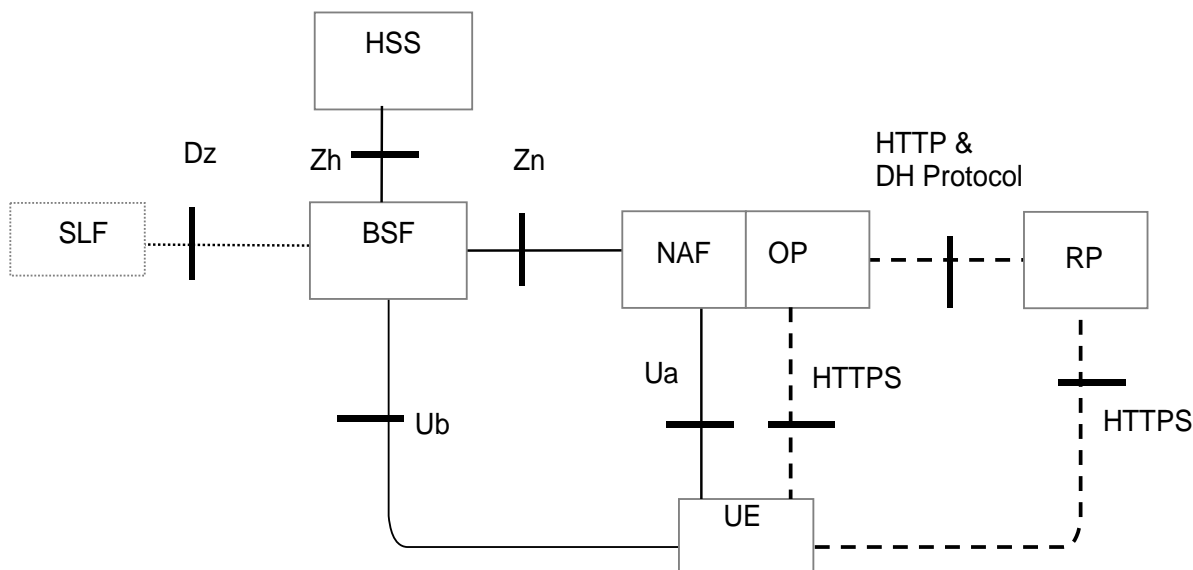

**Figure 4.3-1 Simple OpenID Network Architecture**

The dashed lines indicate the interfaces which originate from the OpenID architecture and the full lines are from the GBA Architecture. The UE utilizes the browser to communicate with the OP. The Ua protocol should be based on TS 24.109 [3] and TS 33.222 [5] section 5.3 and be supported by OP/NAF and UE. The OP/NAF and UE may support the variants of [5] clause 5.4 and 5.5. Even if the figure above shows two interfaces between the NAF/OP and the UE, there is actually only one, since the Ua is the application protocol, which in this case is the OpenID HTTPS protocol.

TS 33.222 [5] only allows the use of HTTPS (i.e. HTTP over TLS). The terminal uses one connection to the NAF/OP server i.e. Ua and the connection to the OP share the same TLS session. Hence only HTTPS shall be used on the connection from the UE to the OP. Due to re-directs this implies that the connection to the RP should also be HTTPS based.

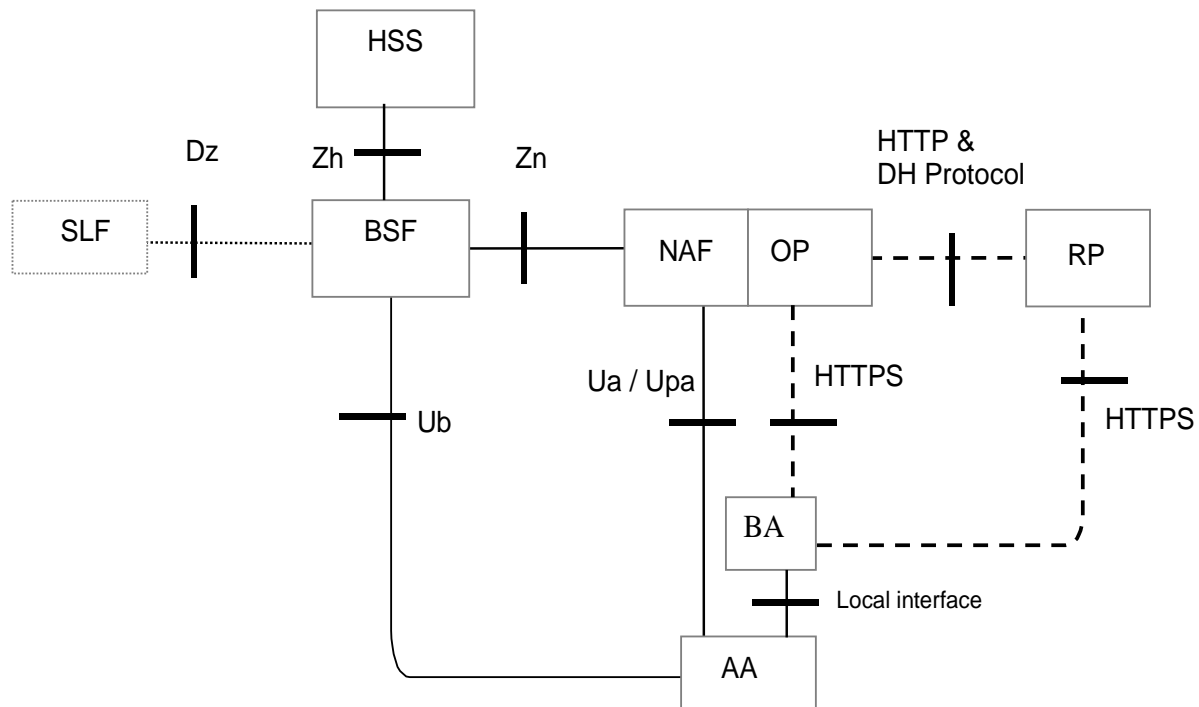

**Figure 4.3-2 OpenID Network Architecture in split terminal scenario**

In the split terminal scenario, the browser and the entity performing the authentication do not reside in the same physical instance. The former UE is here split into a Browsing Agent (BA) that for example may reside in a PC and an Authenticating Agent (AA) that resides in the ME. In the split terminal scenario, the BA and AA do not share the same connection to the OP/NAF. The connections from the BA to the OP and RP should use HTTPS if the BA has HTTPS capabilities.

As above, the dashed lines indicate the interfaces which originate from the OpenID architecture and the full lines are from the GBA Architecture. The BA utilizes the browser to communicate with the OP. Depending on the scenario the BA and the AA may communicate by a local interface. The Ua protocol should be based on TS 24.109 [3] and TS 33.222 [5] section 5.3 and be supported by OP/NAF and AA with UICC. The OP/NAF and AA may support the variants of [5] clause 5.4 and 5.5.

## 4.4 Message Flow for Interworking Scenario

### 4.4.1 Message Flow for direct GBA Interworking Scenario

In the following a message flow is defined to allow the interworking of the GBA Architecture and the OpenID Architecture as defined in clause 4.3 and focuses on the case where the browser resides in the ME: The case, where the browser does not reside in the ME, will be outlined in the next clause.

To initiate OpenID Authentication, the Relying Party should present the end user with a form that has a field for entering a User-Supplied Identifier. The form field's "name" attribute should have the value "openid\_identifier".

1. The browser in the ME sends a User-Supplied Identifier to the Relying Party.
2. The User-Supplied Identifier is normalized as described in Appendix A.1 of [8]. The RP retrieves the address of the OP and performs a discovery of the OP Endpoint URL (based on the User-Supplied Identifier) that the end user wishes to use for authentication.
3. The RP and the OP may then establish a shared secret (called association) using the Diffie-Hellman Key Exchange Protocol. The purpose of this shared secret is that the OP can sign subsequent messages and the RP can verify those messages. The protocol between the OP and the RP lies outside of the 3GPP specifications, but for security reasons it is recommended to secure the RP OP interface properly

NOTE 1: This association using Diffie Hellman is an optional feature in [8] and not required for interworking purposes. If the OP and RP do not both reside under the control of the same MNO, the usage of this option seems strongly advisable.

4. The RP redirects the ME's browser to the OP with an OpenID Authentication Request as defined in chapter 9 in [8]. The RP inserts into the openid.claimed\_id and into the openid.identity fields the user supplied identifier of step 1.
5. The UE sends a HTTPS GET request to the OP
6. The NAF initiates the ME authentication and responds with a HTTPS response code 401 'Unauthorized', which contains a WWW Authenticate header carrying a challenge requesting the UE to use Digest Authentication with GBA as specified in TS 33.222 [5] with server side certificates.
7. If no valid Ks is available, then the UE bootstraps with the BSF as described in TS 33.220 [2], which results in the possession of the UE of a valid Ks. From this the UE can derive the application specific (OpenID specific) Ks\_(ext/int)\_NAF key(s).
8. The ME generates a HTTPS GET request to the NAF. The HTTPS request carries an authorization header containing the B-TID received from the BSF.

NOTE 2: If GBA push is used, the B-TID is not received from the BSF, but part of the GPI contains the P-TID which is used instead of the B-TID.

9. Using the B-TID and NAF\_ID the NAF retrieves the shared application specific NAF key and optionally the USS (if GBA\_U i.e. Ks\_int/ext\_NAF are used then the GUSS must be supported) from the BSF over the web service based Zn reference point. For details see TS 29.109 [7]. The NAF stores the B-TID, the cryptographic keys and the user supplied identifier to allow matching of the OpenID user session and the GBA session. There are different possibilities how the OP/NAF can link the B-TID and user supplied identifier to the permanent user identifier (IMPI) cf. clause 4.5.1.

Since the OpenID is HTTPS based it is recommended that the NAF/OpenID server support for the interworking scenario the Web Service based Zn reference point as specified in [7] TS 29.109. It may support the Diameter based implementation of the Zn reference point.

NOTE3: It is assumed that the OPs are more likely to support web service based reference points than Diameter based reference points.

The OP/NAF may have received a USS may containing authorization information. The OP establishes whether the end user is authorized to perform OpenID Authentication and wishes to do so based on the authorization information stored locally or in the USS. The USS may thereby act as a central authorization and privacy data store. In particular, the USS may contain information about the type of information are allowed to be shared with the relaying party. This authorization information may be contributed by the user but also by the operator based on their business relationship with the relaying party.

10. NAF/OP authenticates the user for OpenID using TS 33.222 section 5.3. The NAF redirects the browser to the return OpenID address i.e. the OP redirects the ME's browser back to the RP with either an assertion that authentication is approved or a message that authentication failed. The response header contains a number of fields defining the authentication assertion which may be protected by the shared secret between OP and RP. The protection is especially important if the OP and the RP do not reside both in the same MNO network.

NOTE4: At this point, the interworking diverges slightly from TS 33.222. In TS 33.222 the NAF responds with a 200 OK message.

11. The RP validates the assertion i.e. checks if the authentication was approved. The authenticated identity of the user is provided in the response message towards the RP. If a shared secret (association) was established in step 3, then it is now used to verify the message from the OP: If the validation of the assertion and the verification of the message (if the shared secret was used) are successful, then the user is logged in to the service of the RP.

If an operator deploys GBA Push as specified by [6] and not GBA, then the MNO may wish to establish the shared secret according to [6]. The step 7 would then be replaced by the GBA credential push message, after that the ME and NAF continue as outlined above.

The figure below outlines the message flow just described:

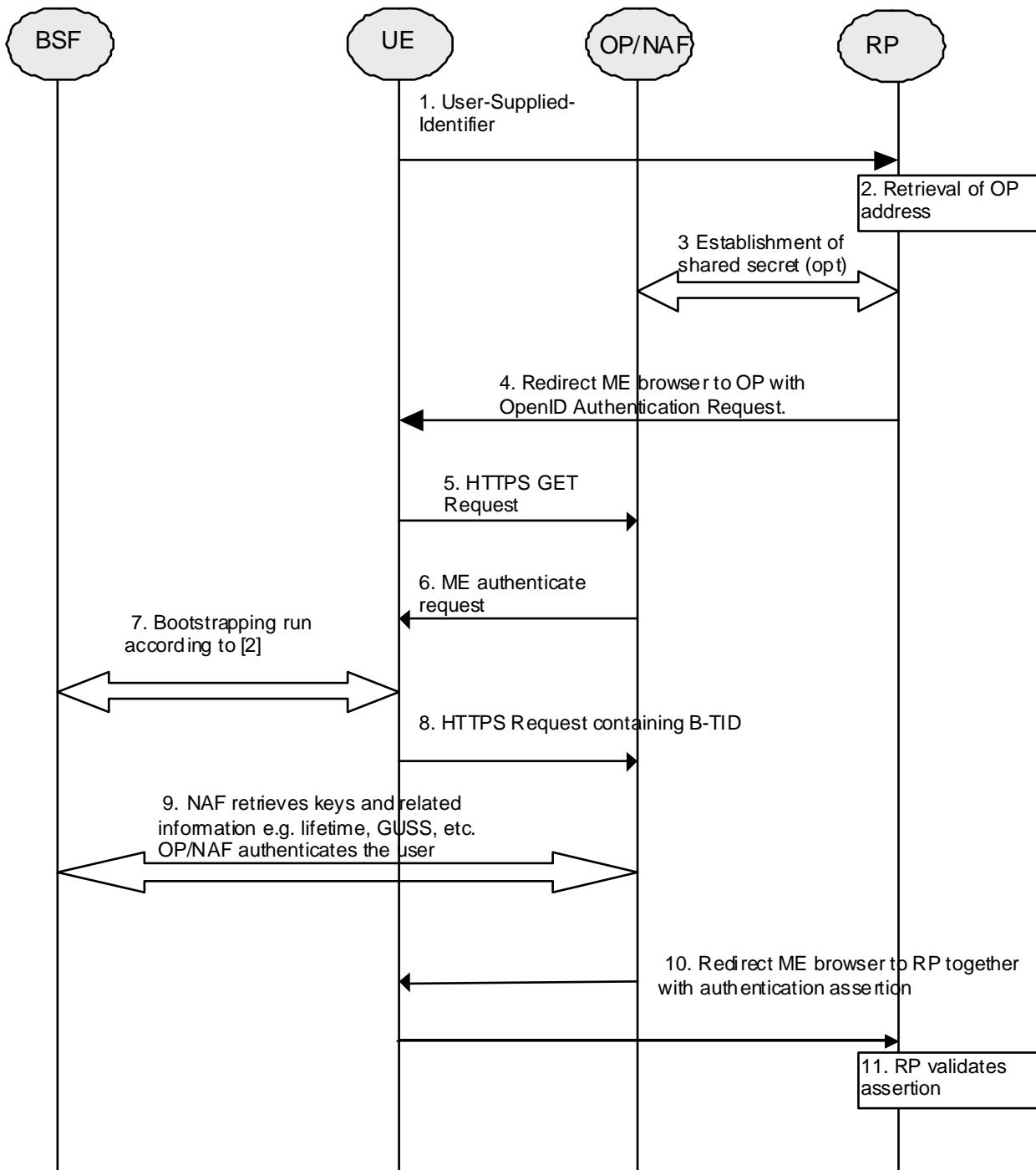

Figure 4.4.1-1 Interworking message flow for GBA / OpenID

## 4.4.2 Message Flow for Split Terminal GBA Interworking Scenario

### 4.4.2.1 General

The following clauses will outline the **split** terminal implementation where the GBA agent (authenticating agent AA) is not located in the same device as the OpenID user Agent (browsing agent BA). The clauses will detail several scenarios where the OpenID session on the browsing agent is authenticated with the help of performing GBA authentication with the authenticating agent.

Two different types of interworking scenarios are described. Scenarios where the AA session (GBA authentication session) is not cryptographically bound to the BA session (OpenID session) are described in clause 4.4.2.3. Scenarios where the AA session is cryptographically bound to the BA session are described in clause 4.4.2.4.

Scenarios in clause 4.4.2.3 expect the user to map the AA session and the BA session e.g. in the form of comparing session identifiers (except when the comparison is done automatically in case there is a local connection).

Scenarios in clause 4.4.2.4 expect the user to copy information from the AA session to the BA session in the form of username/password (except when the information is transferred automatically in case there is a local connection) making the cryptographic binding possible, and therefore it is considered to be more secure.

NOTE: Clauses 4.4.2.3 and 4.4.2.4 describe two alternative ways of implementing the split terminal scenarios. However, terminals can implement scenarios described in both clauses 4.4.2.3 or 4.4.2.4 and deduce the scenario to be used from the received information.

#### 4.4.2.2 Differentiating between Scenarios

The present clause applies to functionality in both 4.4.2.3 and 4.4.2.4.

The OP/NAF and terminal need to be able to differentiate, if they are dealing with direct or split terminal scenarios and which scenarios to apply. Three cases can be identified.

I) AA and BA reside in the same security compound (i.e. situation and message flow for direct GBA interworking in section 4.4.1)

II) AA and BA reside in different devices and the AA and BA are connected with a local link (i.e. situation and message flows for split terminal in section 4.4.2).

II) AA and BA reside in different devices the AA and BA are not connected with a local link (i.e. situation and message flows for split terminal in section 4.4.2)

The following defines how the OP/NAF and terminal are able to determine which interworking scenario to apply.

For case I) It is assumed that if the BA is GBA capable it will behave and indicate GBA support for OP/NAF according to TS 33.222 [5]. If the OP/NAF detects that the BA is indicating support for GBA as specified in TS 33.222 [5] then the OP/NAF shall behave according to clause 4.4.1.

For case II) if the BA detects that the AA is connected to the BA, such as a mobile broadband modem or dongle which is connected with BA e.g. by using bluetooth, wireline or other wireless channel, then the BA shall indicate 'AA connected' to the OP/NAF. If the OP/NAF detects that the BA is indicating that AA is connected as specified in clauses below, then the OP/NAF shall behave according to scenario 3.

For case III) if the AA is not connected to the BA, the BA may be an off-the-shelf browser, e.g. in a web café laptop, and the OP/NAF will not get any of the indications described in cases I and II above. In this case it is up to OP/NAF to decide which of the scenarios 1, 2 or 4 should be used. To differentiate between those, the OP/NAF may have AA capability available provided by other means, e.g. directly by the user stored in a (user) profile or if the user has done the registration for GBA push as specified in GBA Push TS 33.223.

For case III) the following scenarios are possible:

the AA is not connected to the BA, then the following scenarios apply:

- Scenario 1: AA is GBA push enabled and does not communicate directly with BA
- Scenario 2 and 4: AA is GBA enabled, but not GBA push enabled and does not communicate directly with BA

In case the AA is not connected to BA, the OP/NAF decides, based on its knowledge of AA capabilities, whether scenario 1, 2 or 4 should be performed. Recommended usage is to perform scenario 1 if supported by the AA.

#### 4.4.2.3 Scenarios not using cryptographic binding

##### Scenario 1:

In **the first scenario** the GBA session is initiated asynchronously by the server on the authenticating agent AA via a GBA push message. Scenario 1 involves the use of a GBA push challenge which is pushed from the OP/NAF to the AA agent. The high level flow of operations for this scenario is described in Figure 4.4.2-1. Note, that the GBA Push challenge is not an HTTP response and the figure below does not contain all details.

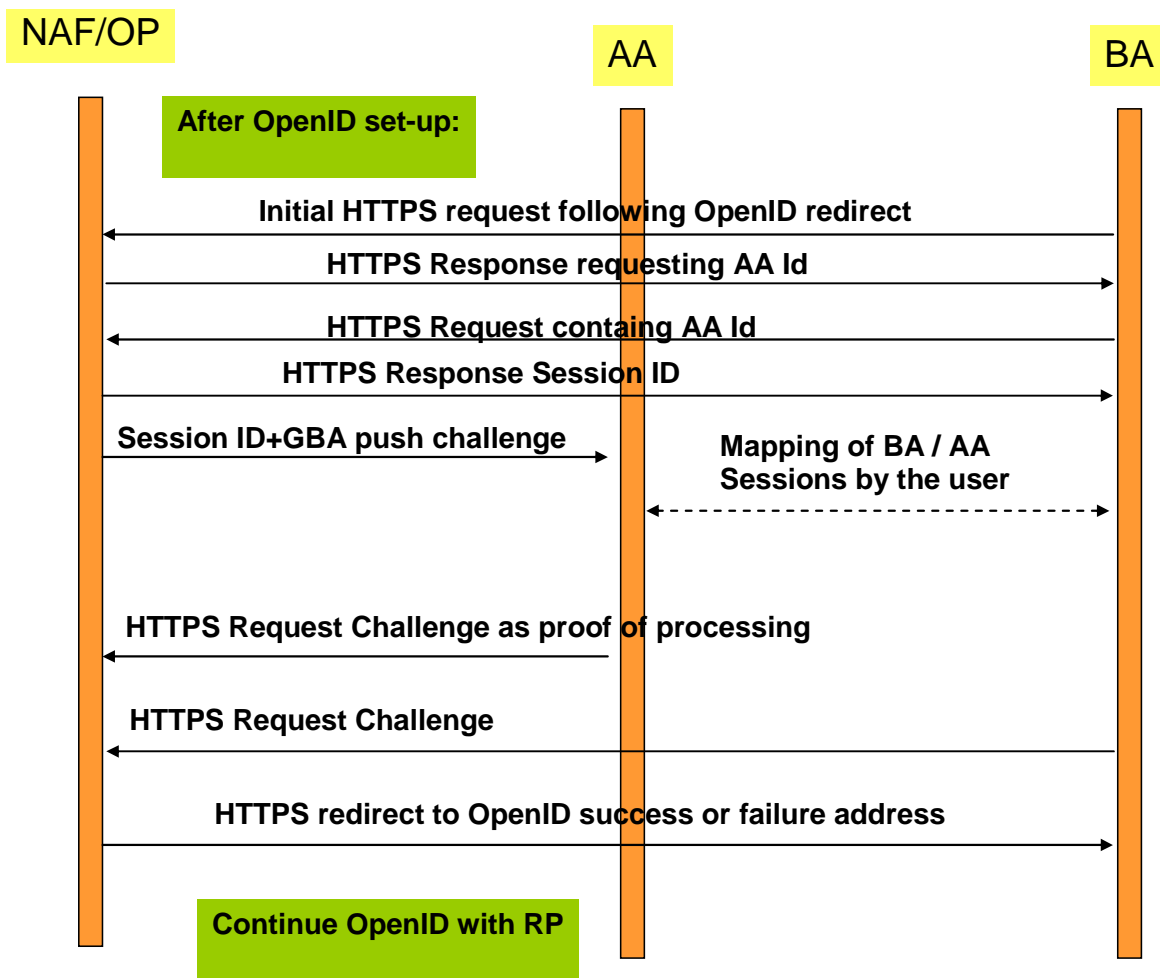

Figure 4.4.2-1: Scenario 1: Use of GBA push challenge

Scenario 2:

**In the second scenario** a GBA session is initiated asynchronously by the server on the authenticating agent AA via a general push message. The scenario 2 involves the use of a general push request from the OP/NAF to the AA, triggering the AA to initiate a GBA session. The high level flow of operations for this scenario is described in Figure 4.4.2-2. Note that the main differences between the scenarios are outlined and not all details are illustrated.



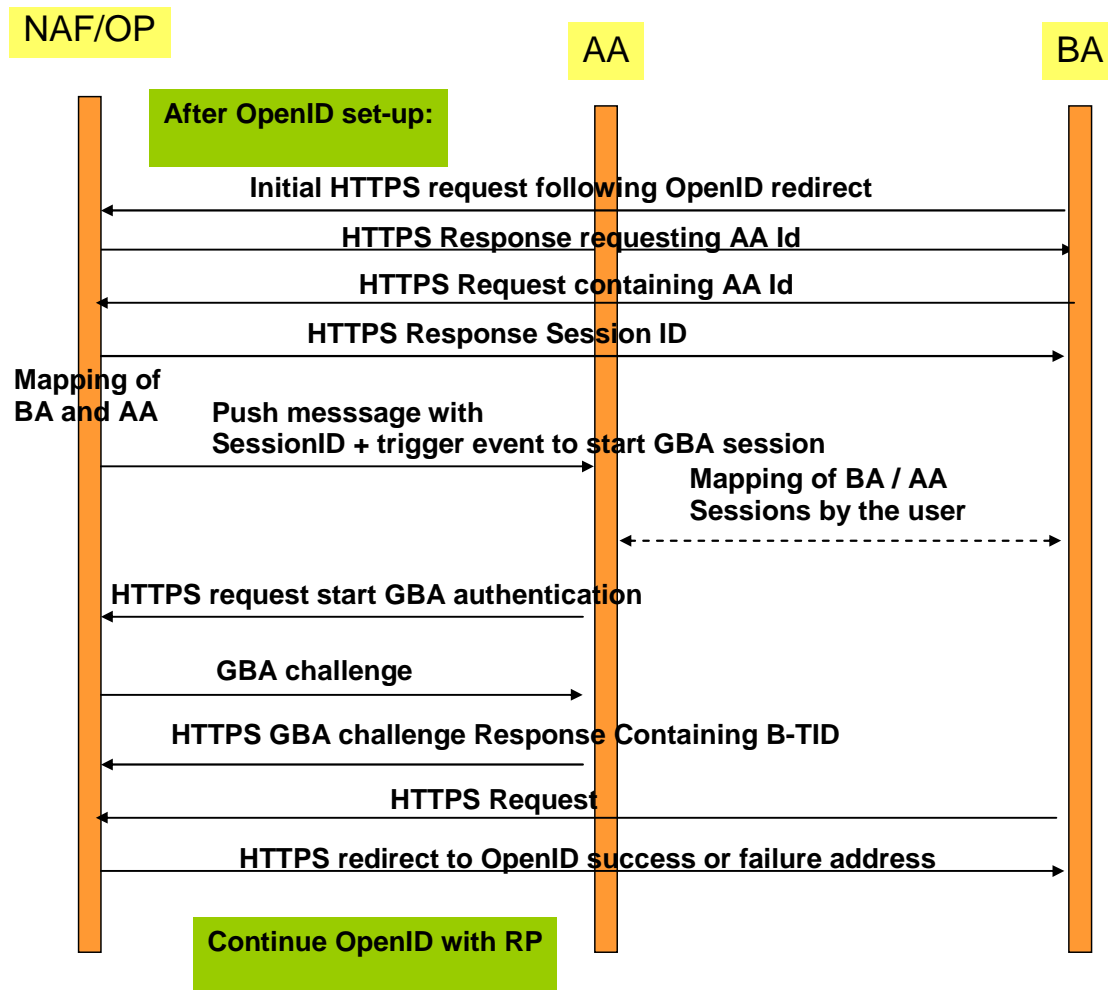

Figure 4.4.2-2: Scenario 2: Use of push request to trigger GBA session

Scenario 3:

In a third scenario, the GBA session is initiated by the authenticating agent. This scenario includes the approach, where the BA and the AA can utilize a local communication link to exchange a session identifier. This scenario involves local communication between the AA and the BA to share a session ID token generated by the OP/NAF. Following the retrieval of this session id token from the BA, the AA will initiate a GBA session with the NAF, providing the session ID token. Once GBA authentication is completed, the BA will be redirected to the OpenID success or failure URL. The high level flow of operations for this scenario for this scenario is described in Figure 4.4.2-3.

In this scenario, the AA and BA need to be securely connected and authenticated to each other, for example they may use a cable connection or BT Security.

Alternatively, the local communication may utilize GBA based security as outlined in TS 33.259 [14]. The BA would act as the remote device and the AA would take the role of the UICC holding device. If the BA has no valid Ks\_local\_device available, then the AA and the BA have to obtain the Ks\_local\_device as described in TS 33.259. This procedure results in the possession of the AA and BA of a valid Ks\_local\_device. The ME and GBA Agent can communicate in secure channel based using the Ks\_local\_device key..

NOTE 1: The case where the AA sends the Ks\_(ext)\_NAF through a secure tunnel to the BA and the BA is using the credential is covered by the normal OpenID-GBA interworking. The OP would only exchange messages with the BA for Ks\_(ext)\_NAF usage and from the OP point of view the BA/AA would be treated then as one entity and would correspond to the variant described in 4.4.1.

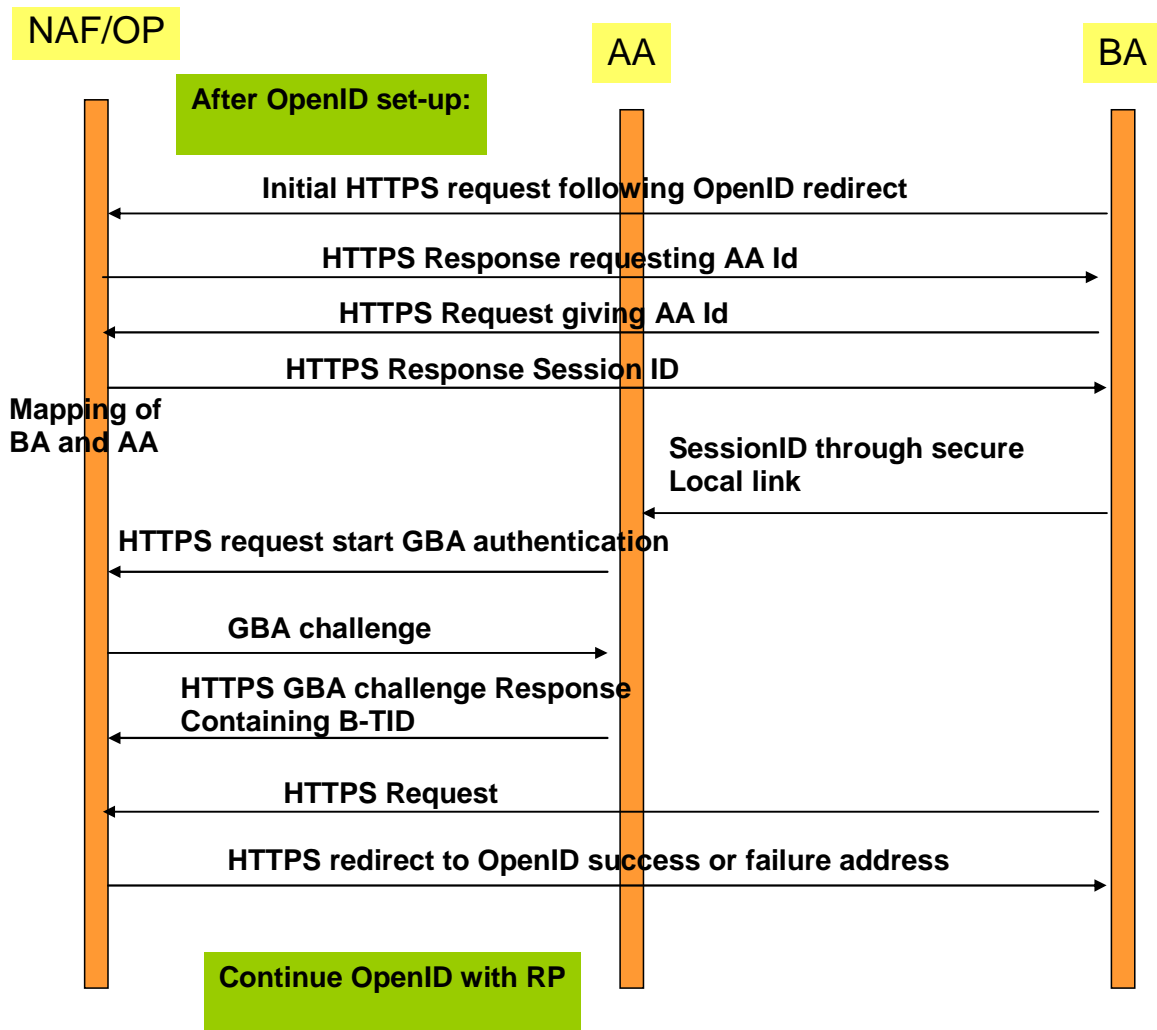

**Figure 4.4.2-3: Scenario 3: linking of AA and BA sessions via session ID transferred from AA to BA**

In the following a message flow is defined to allow the interworking of the GBA Architecture and the OpenID Architecture as defined in clause 4.3 and focuses on the scenarios where there is an Authenticating Agent (AA) and a Browsing Agent (BA) that do not reside in the same physical entity (the case where both reside in the same entity can be found in clause 4.1).

The message flow in scenarios 1 and 2 will involve asynchronous notification of the authenticating Agent (AA). When registering to the OpenID service using a split terminal scenario, then the user has to provide information of how to contact the AA i.e. phone number and operator. This information is mapped to the User-Supplied-Identifier. If no split terminal scenario is utilized, then this information is not required.

To initiate OpenID Authentication, the Relying Party should present the end user with a form that has a field for entering a User-Supplied Identifier. The form field's "name" attribute should have the value "openid\_identifier" as specified in [8].

#### Message flow for scenario 1

1. The Browser Agent sends a User-Supplied Identifier to the Relying Party.
2. The User-Supplied Identifier is normalized as described in Appendix A.1 of [8]. The RP retrieves the address of the OpenID Provider (OP) and performs a discovery of the OP Endpoint URL (based on the User-Supplied Identifier) that the end user wishes to use for authentication.
3. The RP and the OP may then establish a shared secret (called association) using the Diffie-Hellman Key Exchange Protocol. The purpose of this shared secret is that the OP can secure subsequent messages and the RP can verify those messages.

NOTE 2: This association is an optional feature in [8] and not required for interworking purposes. If the OP and RP do not both reside under the control of the same MNO, the usage of this option seems advisable.

4. The RP redirects the Browsing Agent to the OP with an OpenID Authentication Request as defined in chapter 9 in [8].

NOTE 3: The following steps till step 13 differ in the three scenarios.

5. Following this redirection the BA sends a HTTPS GET request to the OP/NAF.
6. The OP/NAF may send a HTTPS response to the BA asking the user to enter an AA identifier, e.g. his or her phone number or any other suitable OpenID identifier which can be mapped to the AA by the OP/NAF due to prior registration of this identifier.
7. After the user has entered the AA identifier the BA sends a second HTTPS request to the OP/NAF carrying this AA identifier.

Steps 6 and 7 are optional and only allowed if the user has entered an OpenID identifier indicating OP driven identifier selection (see Clause 4.2.2) as the User-Supplied Identifier which means that there is no information about the user in the User-Supplied Identifier. In such case, to complete the authentication process using GBA push, the OP/NAF needs the MSISDN of the AA. On the other hand, if the User-Supplied identifier identifies the user, then there needs to be an association between the User-Supplied Identifier and the MSISDN in the OP/NAF, and for such case steps 6 and 7 are not allowed.

NOTE 3a: This allows the user to remain anonymous towards the RP while still allowing GBA authentication.

8. The NAF generates an authentication session identifier. The NAF sends a session identifier to the BA.

NOTE 4: Depending on the implemented scheme, there might be different ways to pass the session identifier. One approach to send the session identifier is to use the realm attribute in the WWW-Authenticate header (see RFC 2617 [17]) in an HTTPS Response. If the NAF intends to populate the field with further information, then the session identifier should be at the end and separated with a ";". Alternatively, the session ID could be carried in the main body of the response for display by the BA.

**Scenarios 1:** The NAF identifies the AA associated to the BA. This association is based on OP/NAF asking the AA identifier from the user as described in steps 6 and 7, or it has been defined previously, possibly at the time where the user has created his OpenID account and enabled usage of GBA (This might be part of the registration procedure, which is out of the scope of the present TR). The AA is identified by an endpoint address i.e. MSISDN which is itself dependant of the communication scheme used to push the GBA push message.

NOTE 5: The session identifier might be alphanumeric or a graphic or picture (or reference to one).

9. **Scenario 1:** The NAF requests the shared key from the BSF as described in TS 33.223 [6] and TS 29.109 [7]. The OP/NAF may have received a USS containing authorization information. The OP/NAF establishes whether the end user is authorized to perform OpenID Authentication and wishes to do so based on the authorization information stored locally or in the USS. There are different possibilities how the OP/NAF can link the B-TID and user supplied identifier to the permanent user identifier (IMPI) cf. clause 4.5.1.

Since the OpenID is HTTPS based it is recommended that the NAF/OpenID server support for the interworking scenario the Web Service based Zpn reference point as specified in [7] TS 29.109. It may support the Diameter based implementation of the Zpn reference point.

NOTE 6: It is assumed that the OPs are more likely to support web service based reference points than Diameter based reference points.

10. **Scenario 1:** The NAF/OP initiates a GBA push request to the AA. This push message contains a GPI used to establish a NAF SA. This request contains also the session identifier and the contact address of the OP/NAF Fully Qualified Domain Name (FQDN).

NOTE 7: The GPI may need to be encapsulated in a higher level protocol enabling to carry the additional information (session identifier and NAF FQDN)

11. **Scenario 1:** The AA and the BA session have to be mapped by the user and give consent to continue with GBA push authentication.

NOTE 8: The session identifier is used to make the link between the BA session and the AA session in order to avoid unauthorized use of GBA authentication. The way this session identifier is processed can vary. In scenario 1 the session identifier may be displayed by both the AA and the BA. The user may visually check that the 2 identifiers displayed match.

NOTE 9: The actual methods of linking e.g. PIN, picture comparison is out of scope of this document.

12. **Scenario 1:** The Ks is derived as outlined in TS 33.223 [6]. Either way this results in the possession by the UE of a valid Ks. From this the UE can derive the application specific (OpenID specific) Ks\_(ext/int)\_NAF key(s). The key generation may be protected with a PIN code

NOTE 10: In scenario 1 a PIN code or a manual user action is required to prevent risk of unauthorized background usage of the GBA authentication. The optional PIN code is not the PIN which guards access to the USIM but a PIN code local to the AA.

NOTE 11: When GBA push is used, then the B-TID is not received from the BSF, but part of the GPI contains the P-TID which is used instead of the B-TID. The P-TID is the GBA Push mirror to the B-TID.

13. **Scenario 1:** The AA responds to the NAF using the P-TID included in the GPI received from the NAF. The P-TID will point to a specific NAF SA in the NAF. The message is a HTTPS Request.

NOTE 12: In scenario 1, the response from the UE serves the purpose to prove to the NAF that the challenge carried by the GPI has been processed successfully.

14. **Scenario 1:** The BA sends a HTTPS Request to the OP/NAF. This may be done explicitly by the user or may be done automatically by the browser without further user interaction

NOTE12a: The purpose of this message is that the OP is able to redirect the BA.

15. **Scenario1:** After getting proof of GPI processing, the OP/NAF redirects the BA to the return OpenID address i.e. the OP redirects the BA back to the RP with either an assertion that authentication is approved or a message that authentication failed. The response header contains a number of fields defining the authentication assertion. If the user only provided the OP Identifier as User-Supplied Identifier to the RP in step 1, it is the responsibility of the OP/NAF to fill the Claimed Identifier field based on user authentication and send this information to the RP.

16. The service provider (RP) checks the assertion (i.e. checks if the authentication was approved) possibly using previously defined shared secrets with the OpenId provider or by direct interrogation of the OpenID provider. Then the user is logged in to the service of the RP.

Figure 4.4.2-4 describes the detailed messages flow for scenario 1 involving the use of GBA push messages.

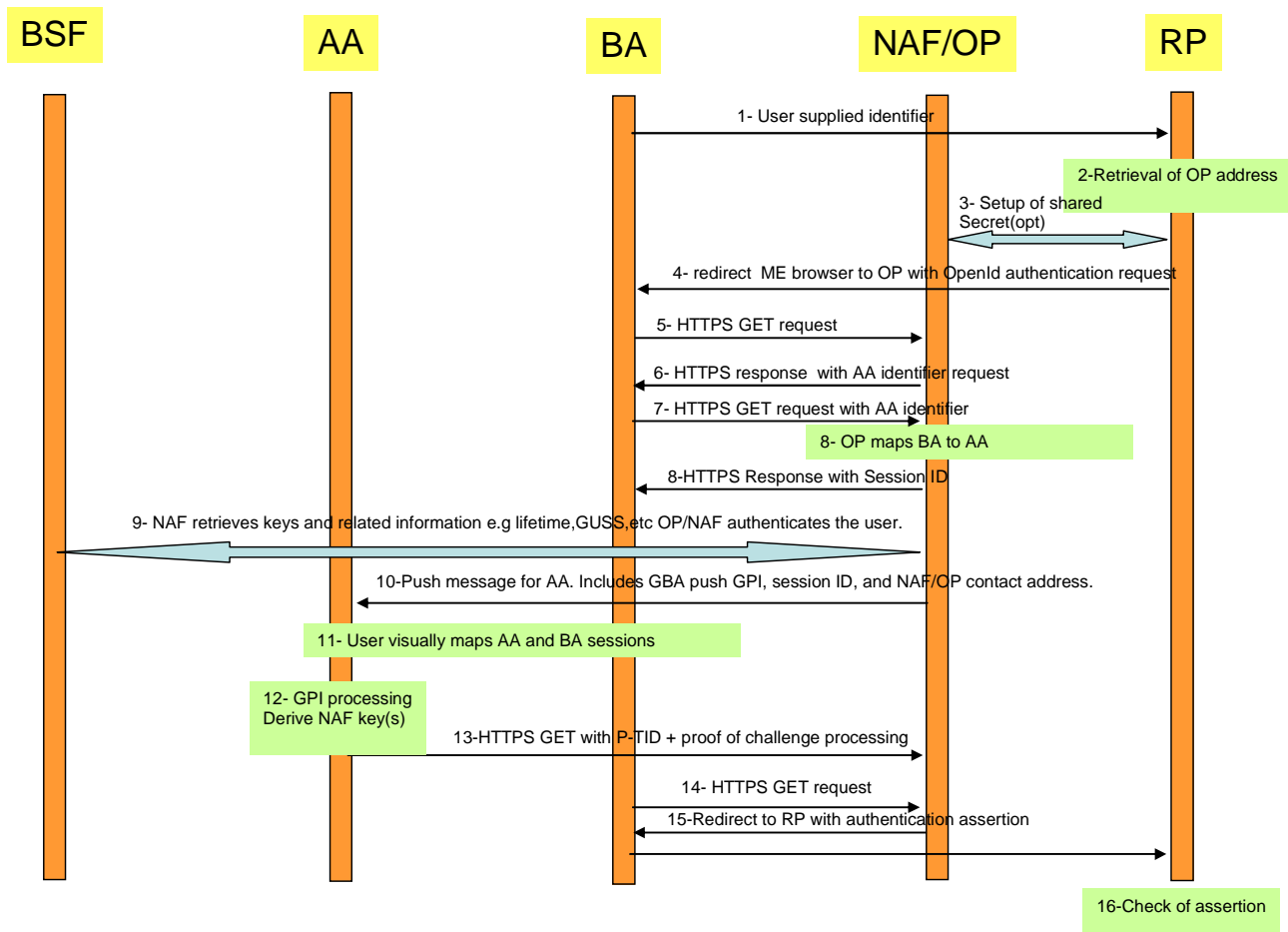

Figure 4.4.2-4: Detailed flow of operations for scenario1 (GBA push)

### Message flow for scenarios 2 and 3

1. The Browser Agent sends a User-Supplied Identifier to the Relying Party.
2. The User-Supplied Identifier is normalized as described in Appendix A.1 of [8]. The RP retrieves the address of the OpenID Provider (OP) and performs a discovery of the OP Endpoint URL (based on the User-Supplied Identifier) that the end user wishes to use for authentication.
3. The RP and the OP may then establish a shared secret (called association) using the Diffie-Hellman Key Exchange Protocol. The purpose of this shared secret is that the OP can secure subsequent messages and the RP can verify those messages.

NOTE 13: This association is an optional feature in [8] and not required for interworking purposes. If the OP and RP do not both reside under the control of the same MNO, the usage of this option seems advisable.

4. The RP redirects the Browsing Agent to the OP with an OpenID Authentication Request as defined in chapter 9 in [8].
5. Following this redirection the BA sends a HTTPS GET request to the OP/NAF. For **Scenario 3** an indication "AA connected" is added.

NOTE 14: The steps 6 to 13 vary from scenario 1.

6. **Scenario 2:** The OP/NAF may send a HTTPS response to the BA asking the user to enter an AA identifier, e.g. his or her phone number or any other suitable OpenID identifier which can be mapped to the AA by the OP/NAF due to prior registration of this identifier.
7. **Scenario 2:** After the user has entered the AA identifier the BA sends a second HTTPS request to the OP/NAF carrying this AA identifier.

Steps 6 and 7 are optional and only allowed if the user has entered an OpenID identifier indicating OP driven identifier selection (see Clause 4.2.2) as the User-Supplied Identifier which means that there is no information about the user in the User-Supplied Identifier. In such case, to complete the authentication process, the OP/NAF needs the MSISDN of the AA. On the other hand, if the User-Supplied identifier identifies the user, then there needs to be an association between the User-Supplied Identifier and the MSISDN in the OP/NAF, and for such case steps 6 and 7 are not allowed.

NOTE 14a: This allows the user to remain anonymous towards the RP while still allowing GBA authentication.

8. The NAF generates an authentication session identifier. The NAF sends a session identifier to the BA.

NOTE 15: Depending on the implemented scheme, there might be different ways to pass the session identifier. One approach to send the session identifier is to use the realm attribute in the WWW-Authenticate header (see RFC 2617 [17]) in an HTTPS response message. If the NAF intends to populate the field with further information, then the session identifier should be at the end and separated with a ";". Alternatively, the session ID could be carried in the main body of the response for display by the BA.

**Scenario 2 and 3:** The NAF identifies the AA associated to the BA. This association is based on OP/NAF asking the AA identifier from the user as described in steps 6 and 7, or it has been defined previously, possibly at the time where the user has created his OpenID account and enabled usage of GBA (This might be part of the registration procedure, which is out of the scope of the present TR). The AA is identified by an endpoint address i.e. MSISDN which is itself dependant of the communication scheme used to push the authentication triggering message.

NOTE 16: The session identifier might be alphanumeric or a graphic or picture (or reference to one).

9. In this step scenarios 2 and 3 differ as follows:

**7a) Scenario 2:** The NAF/OP initiates a push request to the AA. This request is just used to notify the AA to initiate a GBA authentication session with the NAF.

**7b) Scenario 3:** The BA pushes the session identifier and the NAF contact address to the AA via the local link. If the BA and the AA have an established secure tunnel e.g. using TS 33.259 [14], then this could be utilized to send the session ID and the NAF contact address to the AA.

NOTE 17: The most common approach here is to use SMS for the push message to the AA, but also other Push methods might be used like WAP Push, SIP.

10. **Scenario 2 and 3:** The AA receives the push message either from the BA or from the NAF. Upon reception of this push message, the AA and the BA session have to be mapped in order to avoid unauthorized use of GBA authentication. In scenario 2 the user has to do this and give consent to continue with GBA authentication. In scenario 3, this may implicitly be done by using a secure connection between AA and BA and transferring the session identifier.

NOTE 18: The session identifier is used to make the link between the BA session and the AA session. The way this session identifier is processed varies according to the scenario:  
In scenario 2, the session identifier may be displayed by both the AA and the BA. The user may visually check that the 2 identifiers displayed match.  
In Scenario 3, the Session identifier provided by the OP/NAF to the BA is presented by the AA to the BA. The link between the two sessions can therefore be made at the NAF/OP level without the user being involved in the matching operation.

NOTE 19: In scenario 2, a PIN code or other manual user action is required to prevent risk of unauthorized background usage of the GBA authentication.  
In Scenario 3, the need of setting up a local link between the AA and the BA may result from a manual operation and the use of a manual user operation (PIN or key pressing) may be optional.

NOTE 20: **Scenario 2 and 3:** The actual methods of linking e.g. PIN, picture comparison is out of scope of this document. The optional PIN code is not the PIN which guards access to the USIM but a PIN code local to the AA

11. **Scenario 2 and 3:** Upon successful matching of session identifies (and receiving the user's consent in scenario 2) the AA will initiate an GBA bootstrapping run according to TS 33.220 [2] (if no valid shared key is available) and then perform a HTTPS based GBA authentication with the OP/NAF according to TS 33.222 as

outlined in step 10. To that end, the AA sends then an HTTPS GET request to the OP/NAF address contained in the push message.

12. **Scenario 2 and 3:** The NAF initiates AA authentication by responding with an HTTP response code 401 "Unauthorized" which contains a WWW-Authenticate header carrying a challenge requesting the AA to use Digest authentication with GBA as specified in TS 33.222 [5] with server side certificates. The "realm" attribute starts with the prefix "3GPP-bootstrapping@" or "[3GPP-bootstrapping-uicc@](#)".
13. **Scenario 2 and 3:** If no valid Ks is available, available to the AA, then the AA bootstraps with the BSF as described in TS 33.220 [2]. If a valid Ks key exists, then the AA computes the NAF specific key Ks\_(ext/int)\_NAF.
14. **Scenario 2 and 3:** The AA generates a HTTPS GET request to the NAF/OP. The request carries an authorization header carrying the B-TID received from the BSF and a response to the challenge received in step 9 and computed with the (Ks\_(ext/int)\_NAF).
15. **Scenario 2 and 3:** Using the B-TID, and its NAF-ID, the NAF retrieves the shared key Ks\_(ext/int)\_NAF and optionally the USS (if GBA\_U is used, then the GUSS must be supported) from the BSF using the Zn interface, for details see TS 29.109 [7]. There are different possibilities how the OP/NAF can link the B-TID and user supplied identifier to the permanent user identifier (IMPI) cf. clause 4.5.1.

Since the OpenID is HTTPS based it is recommended that the NAF/OpenID server support for the interworking scenario the Web Service based Zn reference point as specified in [7] TS 29.109. It may support the Diameter based implementation of the Zn reference point.

NOTE 21: It is assumed that the OPs are more likely to support web service based reference points than Diameter based reference points.

The OP/NAF may have received a USS containing authorization information. The OP establishes whether the end user is authorized to perform OpenID Authentication and wishes to do so based on the authorization information stored locally or in the USS.

16. **Scenario 2 and 3:** The BA sends a HTTPS Request to the OP/NAF. This may be done explicitly by the user or may be done automatically by the browser without further user interaction or triggered by the AA if local communication is available (i.e. scenario 3).

NOTE21b: The purpose of this message is that the OP is able to redirect the BA.

17. **Scenario 2 and 3:** The OP/NAF authenticates the user for OpenID using TS 33.222 [5] section 5.3. Then the NAF redirects the browser to the return OpenID address i.e. the OP redirects the ME's browser back to the RP with either an assertion that authentication is approved or a message that authentication failed. The response header contains a number of fields defining the authentication assertion. If the user only provided the OP Identifier as User-Supplied Identifier to the RP in step 1, it is the responsibility of the OP/NAF to fill the Claimed Identifier field based on user authentication and send this information to the RP.

NOTE 22: At this point, the interworking diverges slightly from TS 33.222. In TS 33.222 the NAF responds with a 200 OK message directly to the UE, here the BA does not reside in the UE.

18. The service provider (RP) checks the assertion (i.e. checks if the authentication was approved) possibly using previously defined shared secrets with the OpenID provider or by direct interrogation of the OpenID provider. Then the user is logged in to the service of the RP.

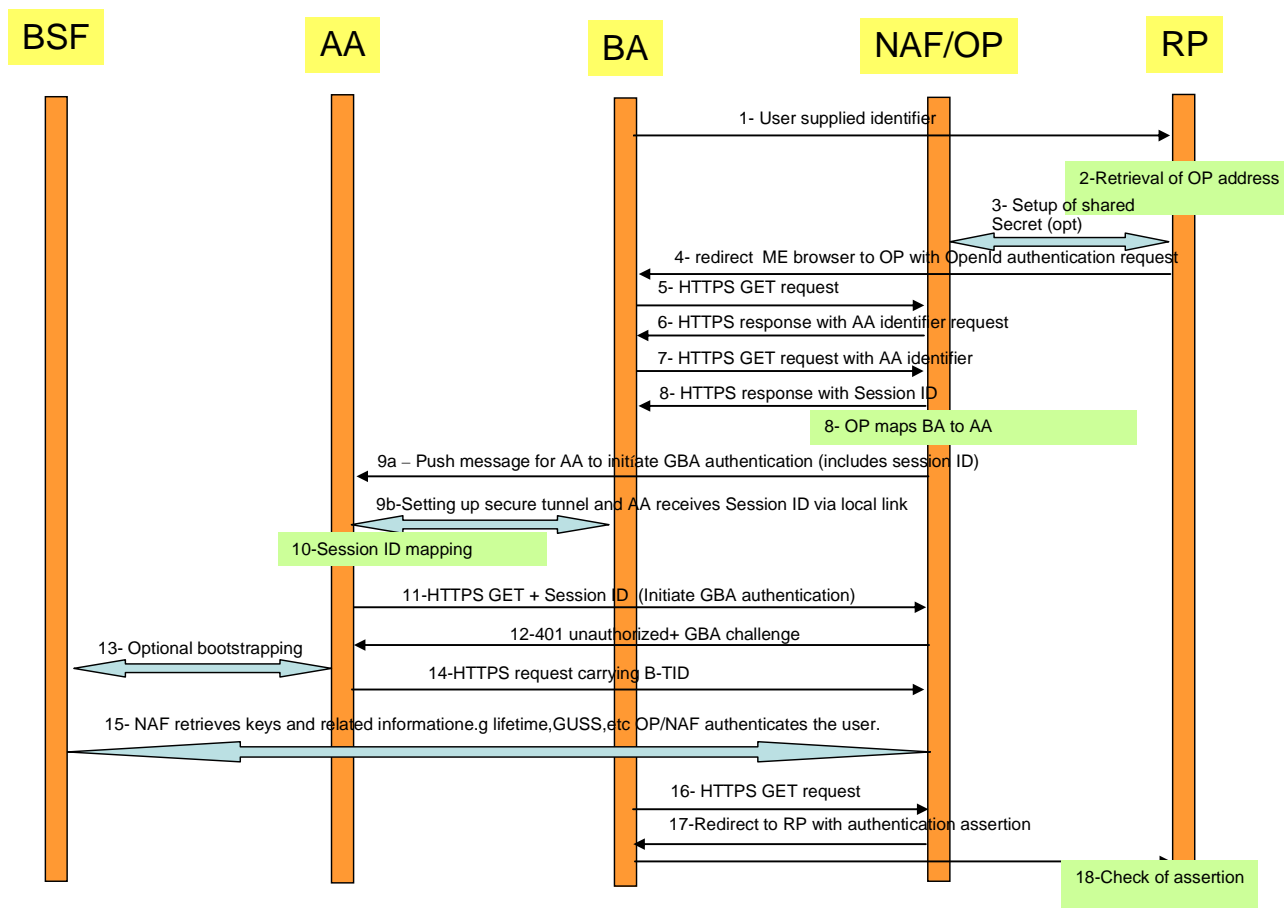

**Figure 4.4.2-5: Detailed flow of operations for scenario 2 and 3 (push message from OP/NAF or BA to trigger GBA authentication)**

NOTE 23: In Scenario 1 and 2 in order to prevent a Denial of Service attack against the terminal that consists out of malicious push messages to the AA the NAF/OP can monitor frequent failed or unfinished authentication attempts and abort the procedure or introduce an artificial delay. Alternatively, a pre-shared password authentication might be utilized before the session identifier is sent to the BA in step 6, but impacts the SSO user experience.

4.4.2.4 Scenarios using cryptographic binding

Scenario 1

In the first scenario the GBA session is initiated asynchronously by the server on the authenticating agent AA via a GBA push message. Scenario 1 involves the use of a GBA push challenge which is pushed from the OP/NAF to the AA agent. The high level flow of operations for this scenario is described in Figure 4.4.2-6. Note, that the GBA Push challenge is not an HTTPS response and the figure below does not contain all details.



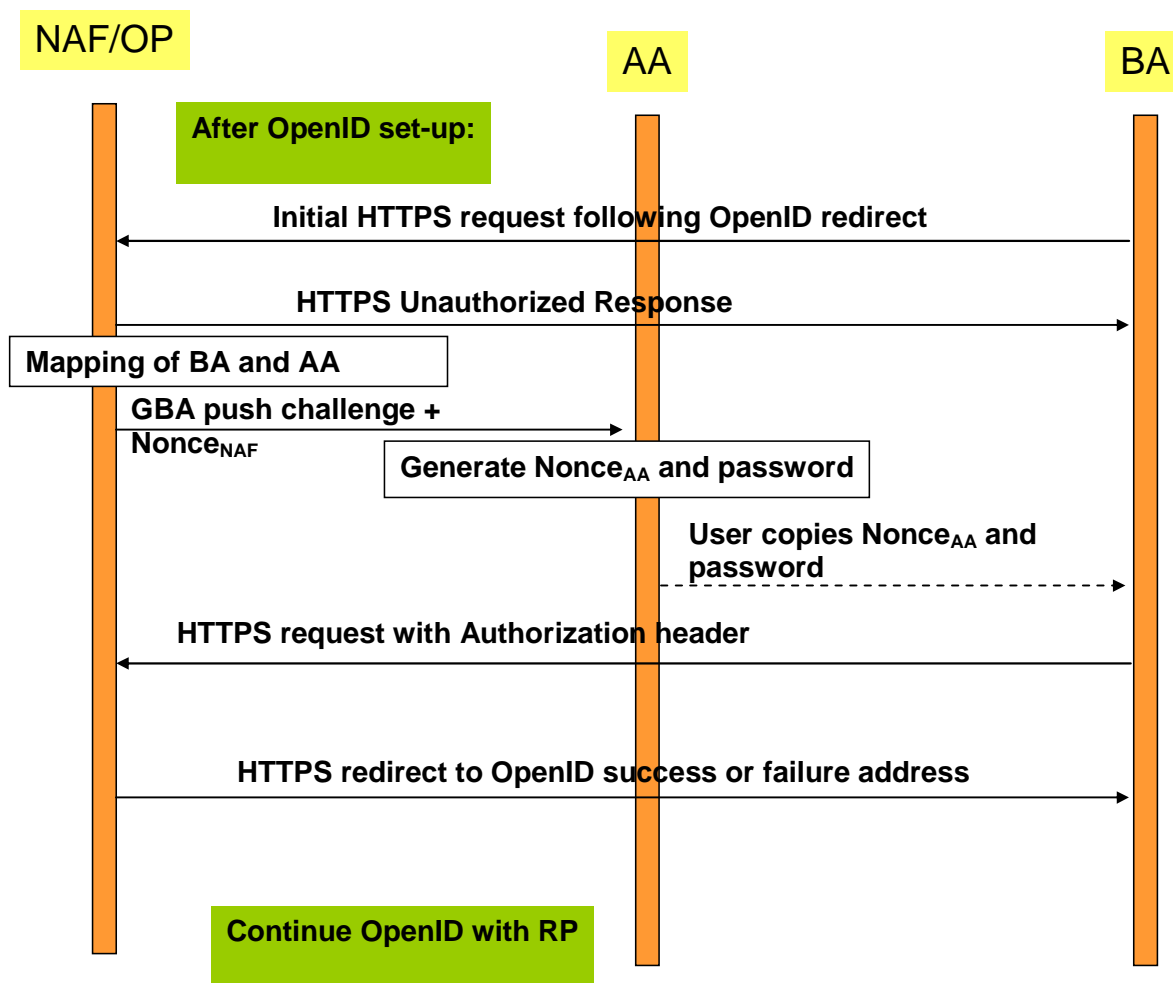

Figure 4.4.2-6: Scenario 1: Use of GBA push challenge

**Scenario 2:**

In the second scenario a GBA session is initiated asynchronously by the server on the authenticating agent AA via a general push message. The scenario 2 involves the use of a general push request from the OP/NAF to the AA, triggering the AA to initiate a GBA session. The high level flow of operations for this scenario is described in Figure 4.4.2-2. Note that the main differences between the scenarios are outlined and not all details are illustrated.

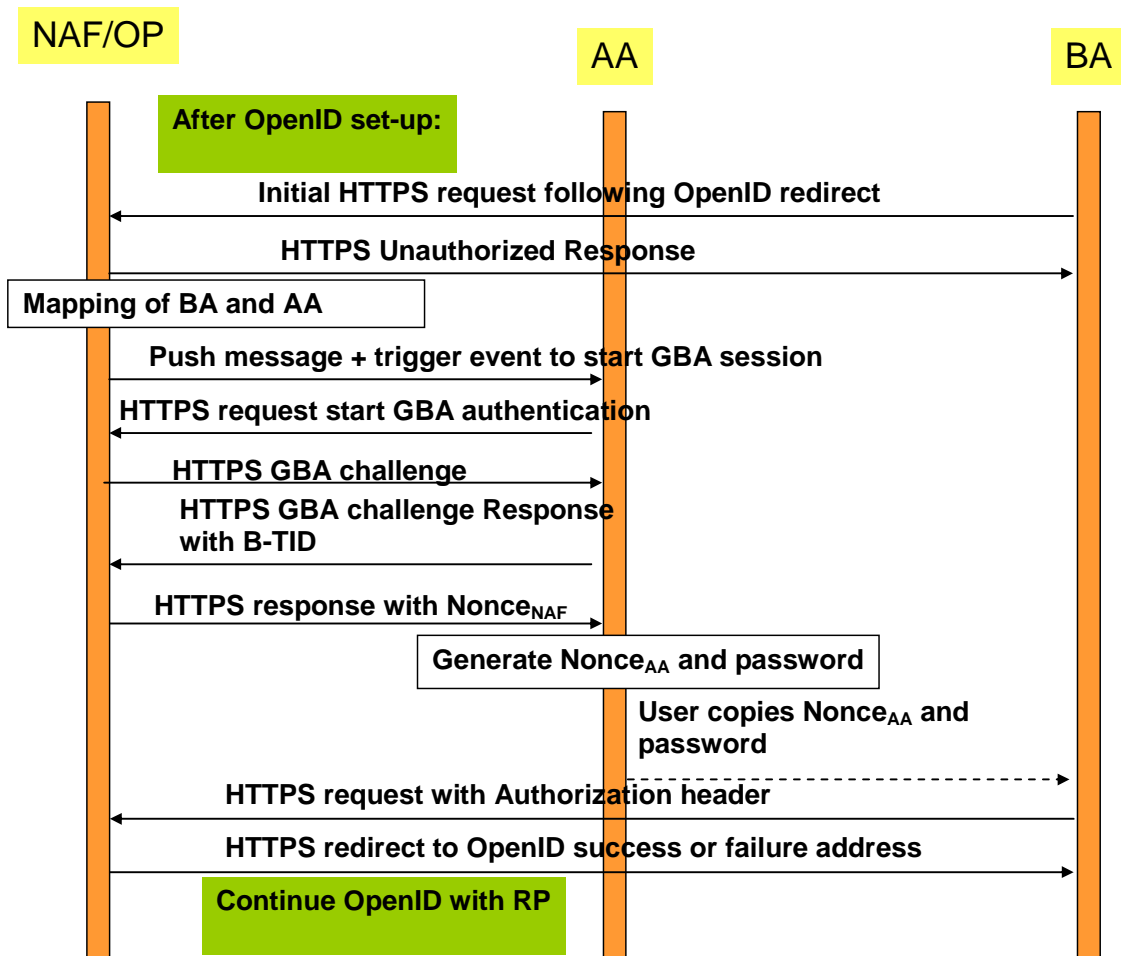

Figure 4.4.2-7: Scenario 2: Use of push request to trigger GBA session

**Scenario 3:**

In a third scenario, the GBA session is initiated by the authenticating agent. This scenario includes the approach, where the BA and the AA can utilize a local communication link. Once GBA authentication is completed, the BA will be redirected to the OpenID success or failure URL. The high level flow of operations for this scenario for this scenario is described in Figure 4.4.2-8.

In this scenario, the AA and BA need to be securely connected and authenticated to each other, for example they may use a cable connection or BT Security.

Alternatively, the local communication may utilize GBA based security as outlined in TS 33.259 [14]. The BA would act as the remote device and the AA would take the role of the UICC holding device. If the BA has no valid *Ks\_local\_device* available, then the AA and the BA have to obtain the *Ks\_local\_device* as described in TS 33.259. This procedure results in the possession of the AA and BA of a valid *Ks\_local\_device*. The ME and GBA Agent can communicate in secure channel based using the *Ks\_local\_device* key.

NOTE 1: The case where the AA sends the *Ks\_(ext)\_NAF* through a secure tunnel to the BA and the BA is using the credential is covered by the normal OpenID-GBA interworking. The OP would only exchange messages with the BA for *Ks\_(ext)\_NAF* usage and from the OP point of view the BA/AA would be treated then as one entity and would correspond to the variant described in 4.4.1.

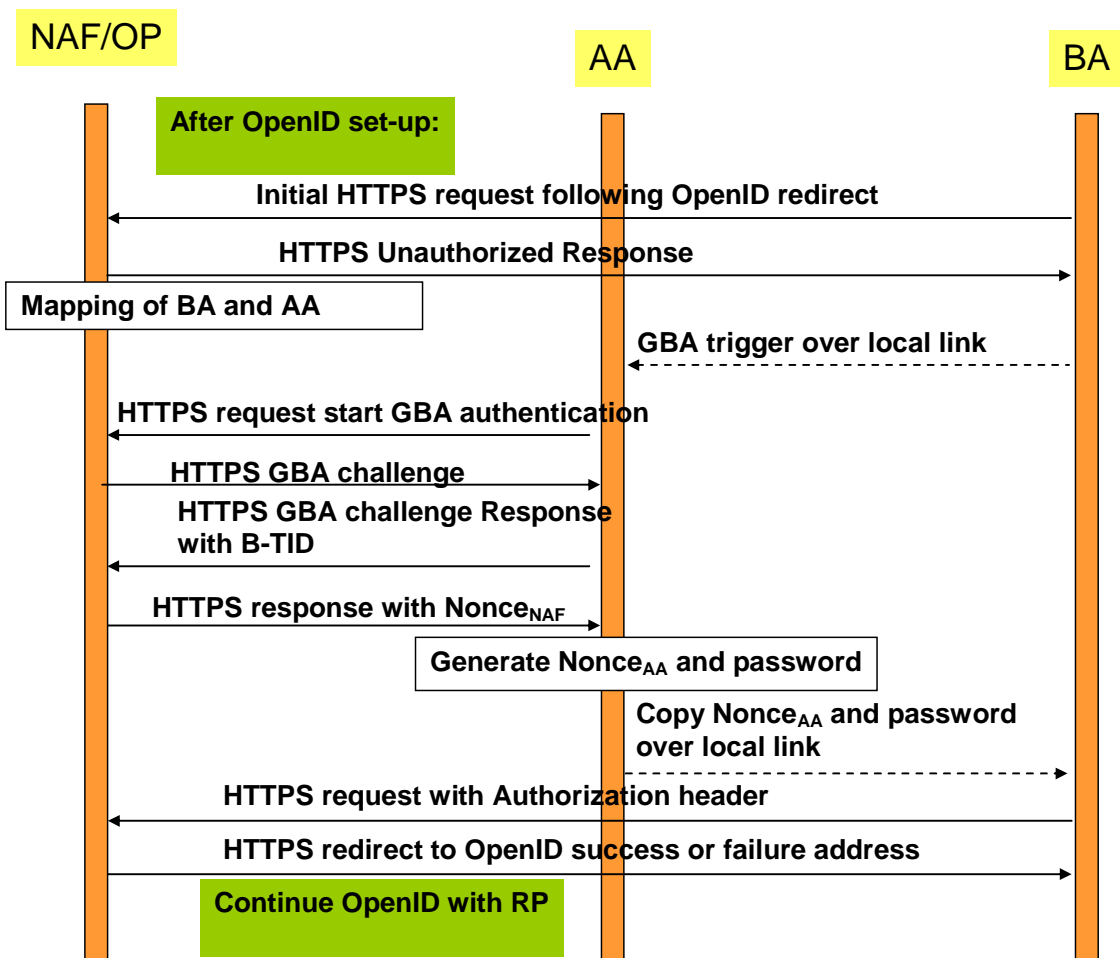
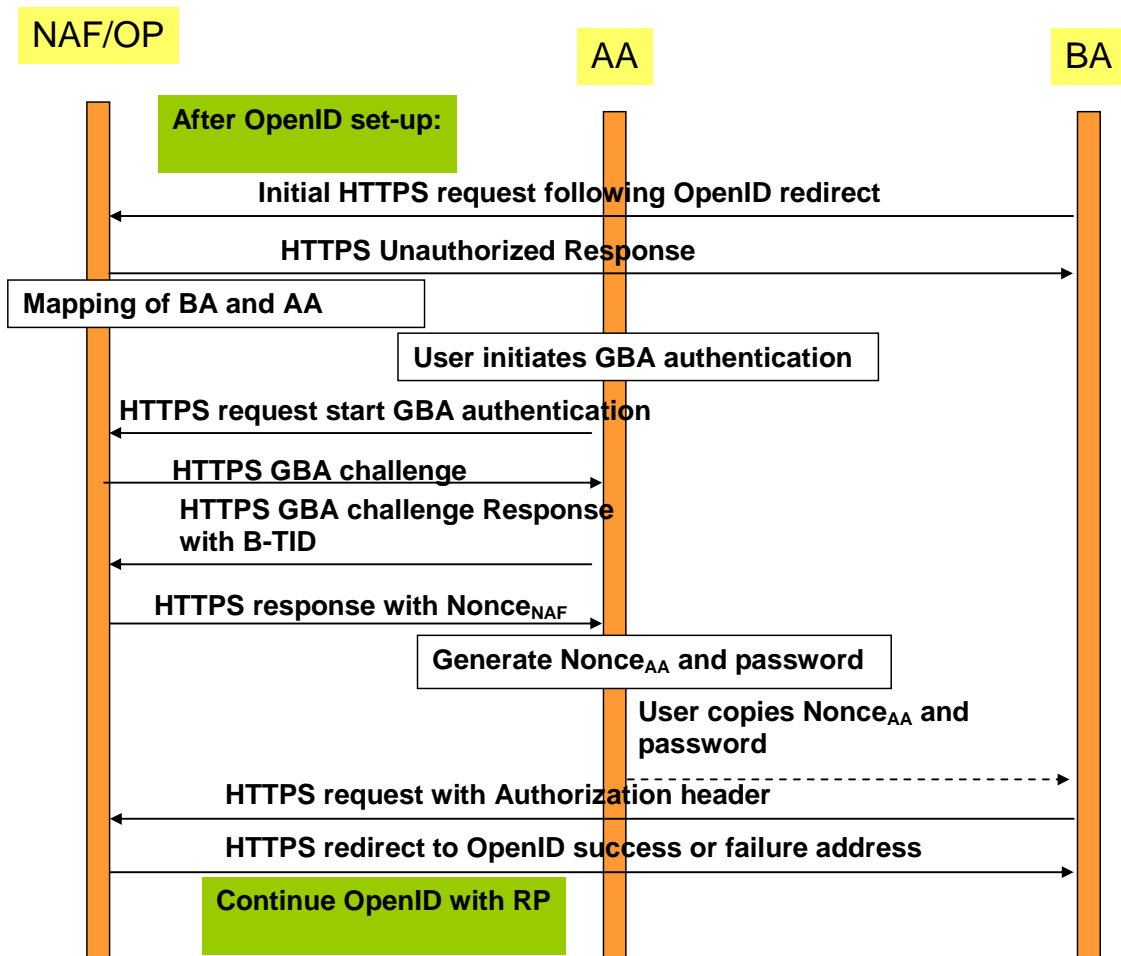

Figure 4.4.2-8: Scenario 3: Use of local link to trigger GBA session

**Scenario 4:**

In the fourth scenario a GBA session is initiated asynchronously by the user on the authenticating agent AA. In this scenario the OP/NAF sends OP/NAF URL to the BA which is displayed to the user who then triggers the AA to initiate a GBA session. The high level flow of operations for this scenario is described in Figure 4.4.2-x. Note that the figure only outlines the main differences between the scenarios and does not all details.



**Figure 4.4.2-9: Scenario 4: User initiates GBA authentication**

In the following a message flow is defined to allow the interworking of the GBA Architecture and the OpenID Architecture as defined in clause 4.3 and focuses on the scenarios where there is an Authenticating Agent (AA) and a Browsing Agent (BA) that do not reside in the same physical entity (the case where both reside in the same entity can be found in clause 4.4.1).

The message flow in scenarios 1 and 2 will involve asynchronous notification of the authenticating Agent (AA). When registering to the OpenID service using a split terminal scenario, then the user has to provide information of how to contact the AA i.e. phone number and operator. This information is mapped to the User-Supplied-Identifier. If no split terminal scenario is utilized, then this information is not required.

To initiate OpenID Authentication, the Relying Party should present the end user with a form that has a field for entering a User-Supplied Identifier. The form field's "name" attribute should have the value "openid\_identifier" as specified in [8].

#### Message flow for scenario 1

1. The Browser Agent sends a User-Supplied Identifier to the Relying Party.
2. The User-Supplied Identifier is normalized as described in Appendix A.1 of [8]. The RP retrieves the address of the OpenID Provider (OP) and performs a discovery of the OP Endpoint URL (based on the User-Supplied Identifier) that the end user wishes to use for authentication.
3. The RP and the OP may then establish a shared secret (called association) using the Diffie-Hellman Key Exchange Protocol. The purpose of this shared secret is that the OP can secure subsequent messages and the RP can verify those messages.

NOTE 2: This association is an optional feature in [8] and not required for interworking purposes. If the OP and RP do not both reside under the control of the same MNO, the usage of this option seems advisable.

4. The RP redirects the Browsing Agent to the OP with an OpenID Authentication Request as defined in chapter 9 in [8].

NOTE 3: The following steps till step 16 differ in the three scenarios.

5. Following this redirection the BA sends a HTTPS GET request to the OP/NAF.
6. The OP/NAF may send a HTTPS response to the BA asking the user to enter an AA identifier, e.g. his or her phone number or any other suitable OpenID identifier which can be mapped to the AA by the OP/NAF due to prior registration of this identifier.
7. After the user has entered the AA identifier the BA sends a second HTTPS request to the OP/NAF carrying this AA identifier.

Steps 6 and 7 are optional and only allowed if the user has entered an OpenID identifier indicating OP driven identifier selection (see Clause 4.2.2) as the User-Supplied Identifier which means that there is no information about the user in the User-Supplied Identifier. In such case, to complete the authentication process using GBA push, the OP/NAF needs the MSISDN of the AA. On the other hand, if the User-Supplied identifier identifies the user, then there needs to be an association between the User-Supplied Identifier and the MSISDN in the OP/NAF, and for such case steps 6 and 7 are not allowed.

NOTE 4: This allows the user to remain anonymous towards the RP while still allowing GBA authentication.

8. **Scenario 1:** The NAF identifies the AA associated to the BA. This association is based on OP/NAF asking the AA identifier from the user as described in steps 6 and 7, or it has been defined previously, possibly at the time where the user has created his OpenID account and enabled usage of GBA (This might be part of the registration procedure, which is out of the scope of the present TR). The AA is identified by an endpoint address i.e. MSISDN which is itself dependant of the communication scheme used to push the GBA push message.
9. **Scenario 1:** The NAF sends an HTTPS unauthorized response to the BA. The BA displays an HTTP Digest Authentication dialogue box to the user.
10. **Scenario 1:** The NAF requests the shared key from the BSF as described in TS 33.223 [6] and TS 29.109 [7]. The OP/NAF may have received a USS containing authorization information. The OP/NAF establishes whether the end user is authorized to perform OpenID Authentication and wishes to do so based on the authorization information stored locally or in the USS. There are different possibilities how the OP/NAF can link the B-TID and user supplied identifier to the permanent user identifier (IMPI) cf. clause 4.5.1.

Since the OpenID is HTTPS based it is recommended that the NAF/OpenID server support for the interworking scenario the Web Service based Zpn reference point as specified in [7] TS 29.109. It may support the Diameter based implementation of the Zpn reference point.

NOTE 5: It is assumed that the OPs are more likely to support web service based reference points than Diameter based reference points.

11. **Scenario 1:** The NAF generates  $\text{Nonce}_{\text{NAF}}$  which will be used to construct the session security identifier. The NAF/OP initiates a GBA push request to the AA. This push message contains a GPI used to establish a NAF SA. This request contains also the  $\text{Nonce}_{\text{NAF}}$ .

NOTE 6: The GPI may need to be encapsulated in a higher level protocol enabling to carry the additional information ( $\text{Nonce}_{\text{NAF}}$ )

12. **Scenario 1:** Upon receiving the GBA push message including the GPI the Ks is derived as outlined in TS 33.223 [6]. Either way this results in the possession by the AA of a valid Ks. From this the AA can derive the application specific (OpenID specific)  $\text{Ks}_{\text{(ext/int)}}_{\text{NAF}}$  key(s). The key generation may be protected with a PIN code.

The AA generates short  $\text{Nonce}_{\text{AA}}$  of 4 digits in length (when coded in alphanumeric) and calculates the session security identifier as follows:

session security identifier =  $\text{KDF}(\text{Nonce}_{\text{AA}}, \text{Ks}_{\text{(ext)}}_{\text{NAF}}, \text{Nonce}_{\text{NAF}})$ . The KDF is specified in TS 33.220 [2].

The AA displays the  $\text{Nonce}_{\text{AA}}$  as username and 4 first digits of the session security identifier (when coded in alphanumeric) as password so that the user can copy them to the BA.

- NOTE 7: From the usability point of view it is essential that the username and the password are both short enough so that the user can copy them over.
- NOTE 8: In scenario 1 a PIN code or a manual user action is required to prevent risk of unauthorized background usage of the GBA authentication. The optional PIN code is not the PIN which guards access to the USIM but a PIN code local to the AA..
- NOTE 9: When GBA push is used, then the B-TID is not received from the BSF, but part of the GPI contains the P-TID which is used instead of the B-TID. The P-TID is the GBA Push mirror to the B-TID.
13. **Scenario 1:** User copies the  $\text{Nonce}_{AA}$  as username and the part of the session security identifier as password from the AA to the BA into the HTTP Digest Authentication dialogue box presented to the user in step 9.
  14. **Scenario 1:** The BA calculates Authorization header values using the  $\text{Nonce}_{AA}$  as username and the part of the session security identifier as password. The BA sends HTTPS request with Authorization header to the OP/NAF.
  15. **Scenario1:** After receiving the HTTPS GET the OP/NAF calculates the session security identifier in the same way as the AA calculated it in step 10. The OP/NAF then authenticates BA by calculating the corresponding digest values and verifies the Authorization header by using the  $\text{Nonce}_{AA}$  and the part of the security session identifier.
  16. **Scenario1:** After getting proof of GPI processing, the OP/NAF redirects the BA to the return OpenID address i.e. the OP redirects the BA back to the RP with either an assertion that authentication is approved or a message that authentication failed. The response header contains a number of fields defining the authentication assertion. If the user only provided the OP Identifier as User-Supplied Identifier to the RP in step 1, it is the responsibility of the OP/NAF to fill the Claimed Identifier field based on user authentication and send this information to the RP.
  17. The service provider (RP) checks the assertion (i.e. checks if the authentication was approved) possibly using previously defined shared secrets with the OpenId provider or by direct interrogation of the OpenID provider. Then the user is logged in to the service of the RP.

Figure 4.4.2-10 describes the detailed messages flow for scenario 1 involving the use of GBA push messages.

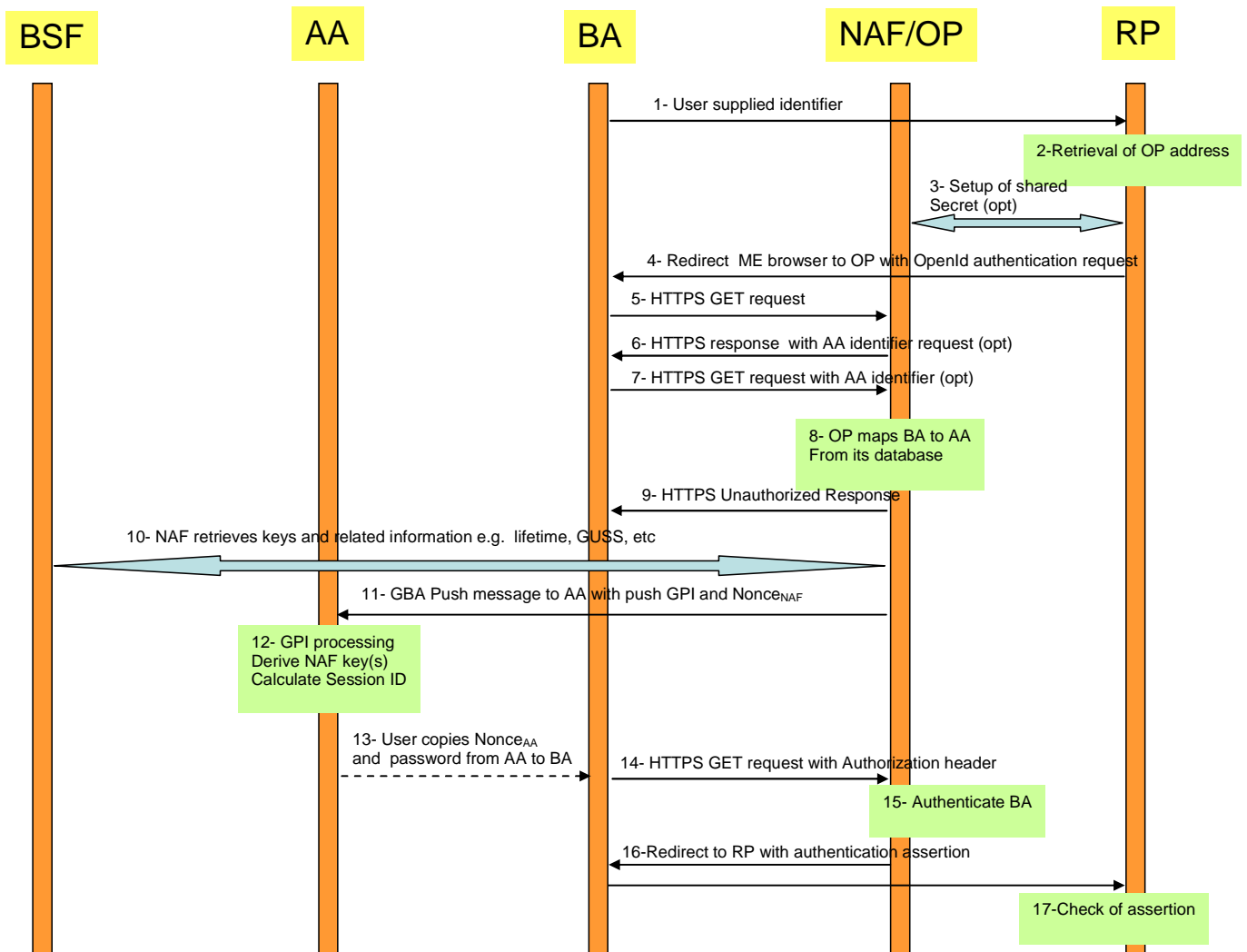

Figure 4.4.2-10: Detailed flow of operations for scenario1 (GBA push)

#### Message flow for scenarios 2, 3 and 4

1. The Browser Agent sends a User-Supplied Identifier to the Relying Party.
2. The User-Supplied Identifier is normalized as described in Appendix A.1 of [8]. The RP retrieves the address of the OpenID Provider (OP) and performs a discovery of the OP Endpoint URL (based on the User-Supplied Identifier) that the end user wishes to use for authentication.
3. The RP and the OP may then establish a shared secret (called association) using the Diffie-Hellman Key Exchange Protocol. The purpose of this shared secret is that the OP can secure subsequent messages and the RP can verify those messages.

NOTE 10: This association is an optional feature in [8] and not required for interworking purposes. If the OP and RP do not both reside under the control of the same MNO, the usage of this option seems advisable.

4. The RP redirects the Browsing Agent to the OP with an OpenID Authentication Request as defined in chapter 9 in [8].
5. Following this redirection the BA sends a HTTPS GET request to the OP/NAF. For **Scenario 3** an indication 'AA connected' is added.

NOTE 11: The steps 6 to 13 vary from scenario 1.

6. **Scenario 2 and 4:** The OP/NAF may send a HTTPS response to the BA asking the user to enter an AA identifier, e.g. his or her phone number or any other suitable OpenID identifier which can be mapped to the AA by the OP/NAF due to prior registration of this identifier.

7. **Scenario 2 and 4:** After the user has entered the AA identifier the BA sends a second HTTPS request to the OP/NAF carrying this AA identifier.

Steps 6 and 7 are optional and only allowed if the user has entered an OpenID identifier indicating OP driven identifier selection as the User-Supplied Identifier which means that there is no information about the user in the User-Supplied Identifier. In such case, to complete the authentication process, the OP/NAF needs the MSISDN of the AA. On the other hand, if the User-Supplied identifier identifies the user, then there needs to be an association between the User-Supplied Identifier and the MSISDN in the OP/NAF, and for such case steps 6 and 7 are not allowed.

NOTE 12: This allows the user to remain anonymous towards the RP while still allowing GBA authentication.

8. **Scenario 2, and 3 and 4:** The NAF sends an HTTPS Unauthorized response to the BA. . Additionally, for scenario 2 the BA displays an HTTP Digest Authentication dialogue box to the user asking for authentication; for scenario 3 the HTTPS message includes OP/NAF contact address which is to be transferred to the AA over the local link.  
for scenario 4 the HTTPS message includes OP/NAF URL which is displayed to the user to be written by the user to AA's browser and the BA displays an HTTP Digest Authentication dialogue box to the user asking for authentication.
9. **Scenario 2 and 3 and 4:** The NAF identifies the AA associated to the BA. This association is based on OP/NAF asking the AA identifier from the user as described in steps 6 and 7, or it has been defined previously, possibly at the time where the user has created his OpenID account and enabled usage of GBA (This might be part of the registration procedure, which is out of the scope of the present TR). The AA is identified by an endpoint address i.e. MSISDN which is itself dependant of the communication scheme used to push the authentication triggering message.

10. In this step scenarios 2 and 3 differ as follows:

**10a) Scenario 2:** The NAF/OP initiates a push request to the AA. This request is used to notify the AA to initiate a GBA authentication session with the OP/NAF. The push request includes the OP/NAF contact address.

**10b) Scenario 3:** The BA pushes the OP/NAF contact address to the AA via the local link. The need of setting up a local link between the AA and the BA may result from a manual operation. If the BA and the AA have an established secure tunnel e.g. using TS 33.259 [14], then this could be utilized.

**10c) Scenario 4:** If OP/NAF contact address (i.e. URL) was displayed to the user in step 8, the user writes the OP/NAF URL to the AA browser to initiate a GBA authentication session with the OP/NAF.

NOTE 13: The most common approach here is to use SMS for the push message to the AA, but also other Push methods might be used like WAP Push, SIP.

11. **Scenario 2 and 3 and 4:** The AA receives the trigger to initiate GBA authentication either from the BA or from the NAF or from the user. Upon reception of this trigger, the AA may request user's consent in order to avoid unauthorized use of GBA authentication.  
In scenario 2 and 4 the user has to give consent to continue with GBA authentication, e.g. in the form of a PIN. In scenario 3, PIN may be used, or consent may implicitly be given by using a secure connection between AA and BA and transferring the security session identifier, and the use of a manual user operation (PIN or key pressing) may be optional.

Upon receiving the trigger to initiate GBA authentication and possibly the user's consent the AA will initiate an GBA bootstrapping run according to TS 33.220 [2] (if no valid shared key is available) and then perform a HTTPS based GBA authentication with the OP/NAF according to TS 33.222 as outlined in step 10. To that end, the AA sends then an HTTP GET request to the OP/NAF.

NOTE 13a: The optional PIN code is not the PIN which guards access to the USIM but a PIN code local to the AA.

12. **Scenario 2 and 3 and 4:** The NAF initiates AA authentication by responding with an HTTPS response code 401 "Unauthorized" which contains a WWW-Authenticate header carrying a challenge requesting the AA to use Digest authentication with GBA as specified in TS 33.222 [5] with server side certificates. The "realm" attribute starts with the prefix "3GPP-bootstrapping@" or "[3GPP-bootstrapping-uicc@](#)".



13. **Scenario 2 and 3 and 4:** If no valid  $K_s$  is available to the AA, then the AA bootstraps with the BSF as described in TS 33.220 [2]. If a valid  $K_s$  key exists, then the AA computes the NAF specific key  $K_{s\_(\text{ext/int})\_NAF}$ .
14. **Scenario 2 and 3 and 4:** The AA generates a HTTPS GET request to the NAF/OP. The request carries an authorization header carrying the B-TID received from the BSF and a response to the challenge received in step 9 and computed with the  $(K_{s\_(\text{ext/int})\_NAF})$ .
15. **Scenario 2 and 3 and 4:** Using the B-TID, and its NAF-ID, the NAF retrieves the shared key  $K_{s\_(\text{ext/int})\_NAF}$  and optionally the USS (if GBA\_U is used, then the GUSS must be supported) from the BSF using the Zn interface, for details see TS 29.109 [7]. The OP/NAF authenticates the user for OpenID using TS 33.222 [5] section 5.3. There are different possibilities how the OP/NAF can link the B-TID and user supplied identifier to the permanent user identifier (IMPI) cf. clause 4.5.1.

Since the OpenID is HTTPS based it is recommended that the NAF/OpenID server support for the interworking scenario the Web Service based Zn reference point as specified in [7] TS 29.109. It may support the Diameter based implementation of the Zn reference point.

NOTE 14: It is assumed that the OPs are more likely to support web service based reference points than Diameter based reference points.

The OP/NAF may have received a USS containing authorization information. The OP establishes whether the end user is authorized to perform OpenID Authentication and wishes to do so based on the authorization information stored locally or in the USS.

16. **Scenario 2 and 3 and 4:** The NAF generates  $\text{Nonce}_{NAF}$  which will be used to construct the security session identifier. In the HTTP(S) 200 OK message the OP/NAF sends the  $\text{Nonce}_{NAF}$  to the AA.
17. **Scenario 2 and 3 and 4:** The AA generates short  $\text{Nonce}_{AA}$  of 4 digits in length (when coded in alphanumeric) and calculates the security session identifier as follows:  
security session identifier =  $\text{KDF}(\text{Nonce}_{AA}, K_{s(\text{ext})\_NAF}, \text{Nonce}_{NAF})$ . The KDF is specified in TS 33.220 [2]. The AA displays the  $\text{Nonce}_{AA}$  as username and and 4 first digits of the security session identifier as password to the user.

NOTE 15: From the usability point of view it is essential that the username and the password are both short enough so that the user can copy them over.

18. In this step scenarios 2, 3 and 4 differ as follows:

Step 18a and c: **Scenario 2 and 4:** User copies the  $\text{Nonce}_{AA}$  as username and the part of the security session identifier as password from the AA to the BA into the HTTP Digest Authentication dialogue box presented to the user in step 6. Step 19 will be triggered when the user has done this.

Step 18b: **Scenario 3:** The AA sends  $\text{Nonce}_{AA}$  as username and the part of the security session identifier as password from the AA over the local link to the BA to be used in HTTP Digest Authentication. No user interaction is required to trigger step 19 as the security session identifier can be automatically sent to BA's browser.

19. **Scenario 2 and 3 and 4:** The BA calculates Authorization header values using the  $\text{Nonce}_{AA}$  as username and the part of the security session identifier as password. The BA sends an HTTPS request with Authorization header to the OP/NAF.
20. **Scenario 2 and 3 and 4:** After receiving the HTTPS GET the OP/NAF calculates the security session identifier in the same way as the AA calculated it in step 17. The OP/NAF then authenticates BA by calculating the corresponding digest values and verifies the Authorization header by using the  $\text{Nonce}_{AA}$  and security session identifier.
21. **Scenario 2 and 3 and 4:** The OP/NAF redirects the browser to the return OpenID address i.e. the OP/NAF redirects the BA's browser back to the RP with either an assertion that authentication is approved or a message that authentication failed. The response header contains a number of fields defining the authentication assertion. If the user only provided the OP Identifier as User-Supplied Identifier to the RP in step 1, it is the responsibility of the OP/NAF to fill the Claimed Identifier field based on user authentication and send this information to the RP.

22. **Scenario 2 and 3 and 4:** The service provider (RP) checks the assertion (i.e. checks if the authentication was approved) possibly using previously defined shared secrets with the OpenID provider or by direct interrogation of the OpenID provider. Then the user is logged in to the service of the RP.

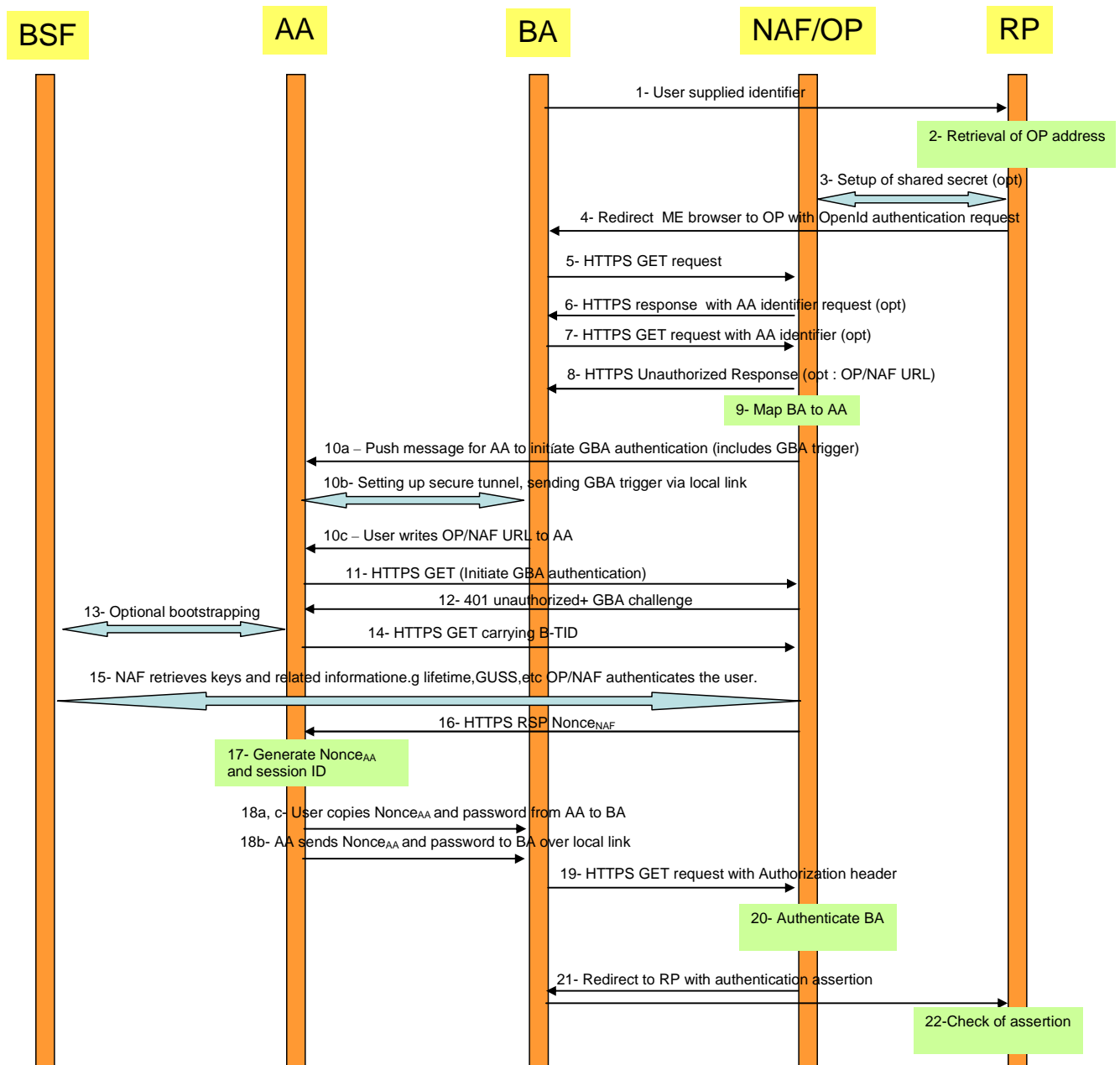

**Figure 4.4.2-11: Detailed flow of operations for scenario 2, 3 and 4 (push message from OP/NAF or BA to trigger GBA authentication)**

NOTE 16: In Scenario 1 and 2 in order to prevent a Denial of Service attack against the terminal that consists out of malicious push messages to the AA the NAF/OP can monitor frequent failed or unfinished authentication attempts and abort the procedure or introduce an artificial delay. Alternatively, a pre-shared password authentication might be utilized, but this impacts the SSO user experience.

## 4.5 Mapping of Concepts

### 4.5.1 Identifiers in OpenID and GBA

In OpenID we have two kinds of identifiers:

- An Identifier in form of a URI or XRI that is used between the OP and RP.
- An User Supplied Identifier that either has already the format of an URL, or if not it is normalized according to rules in [8] and converted into an Identifier.

In GBA we have the following identities:

- Bootstrapping Transaction Identifier (B-TID) which identifies the generated key(s) and can be used to identify an authenticated GBA user.
- Optional identities are IMPI / IMSI or other kind of identifiers that are stored in the User Security Settings (USS)

The NAF / OP can receive the following identities from the BSF

- IMPI or MSISDN, if the BSF is configured to send one or both of them.
- Other user identifiers, but those need to be stored in the USS [7].

Hence, for the interworking of GBA with OpenID the user should use an MNO specific identifier recognizable by the NAF. It is recommended that when the user registers to an OpenID enabled service, then the browser thereby provides information about the operator domain to ensure that the OpenID discovery procedure can be utilized successfully. This can be done by using MSISDN or pseudonyms (if supported).

If only the MSISDN is intended to be used as OpenID identifier by the user, then this mapping between OpenID identifier and MSISDN may be done by one of the following means:

First, the mapping may take place at the UE. This may be implemented as part of a browser plugin. The browser provides the discovered OpenID identifier along with the HTTP page when the user accesses the relying party's webpage for usage with OpenID.

Alternatively, the RP may perform the MSISDN to OpenID identifier lookup. This step assumes that the user enters the MSISDN into the logon window or alternatively it is entered automatically as a browser feature.

The standard OpenID discovery step should remain unmodified and it requires an OpenID identifier. Hence, the MSISDN identifier has to be translated to the OpenID identifier and the ENUM procedure is utilized for this purpose. A description about ENUM can be found in RFC 3761 [18]

NOTE: The basic idea is to convert a telephone number into a string such that it can be used for a DNS lookup and to identify available services. A new service would be the OpenID identifier that could then be retrieved as a DNS resource record.

Registration of this new service is required as shown in the following example taken from RFC 3761 [18]:

```
$ORIGIN 3.8.0.0.6.9.2.3.6.1.4.4.e164.arpa.
NAPTR 10 100 "u" "E2U+openid"
"!^.*$!http:exampleuser.livejournal.com!" .
```

Once the OpenID identifier is available to the Relying Party it is normalized, as described in Appendix A.1 of [8]. The RP retrieves the address of the OP and performs a discovery of the OP Endpoint URL (based on the User-Supplied Identifier) that the end user wishes to use for authentication.

If USSes are supported by the HSS, then the OpenID User Supplied Identifier may be stored in the USS.

The following Ua protocol identifier is used:

- For HTTP Digest with TLS the Ua protocol identifier is 0x01,0x00,0x01,yy,zz where yy,zz is the ciphersuite used in the TLS tunnel as specified in Annex H.3 of TS 33.220 [2].

There are three identifiers in OpenID with GBA inter-networking : claimed identifier (user-supplied identifier), BTID, and permanent user identifier IMPI. Binding is required among these identifiers to prove that someone actually controls a claimed identifier (main claim of OpenID). This can be done in several ways:

- 1) OP is provisioned with claimed identifier and IMPI. OP receives IMPI from BSF during BTID verification (e.g. step 9 from section 4.4.1) step. OP verifies the binding between received IMPI and claimed identifier.

NOTE: IMPI should be sent to OP only if the OP resides in the operator domain.

- 2) Claimed identifier and IMPI are stored in the BSF. BSF sends claimed identifier to the OP as a USS field during BTID verification (e.g. step 9 from section 4.4.1) step. OP sends the received claimed identifier to the RP.

Without such relationship, there is no binding between claimed identifier and IMPI - meaning OP cannot say who is the actual user.

## 4.5.2 Association Session Concept

In OpenID an association session is established between a Relying Party (RP) and the OpenID Provider. A shared secret is established, which is used to verify the subsequent protocol messages. The association session is initiated by a direct request from a RP to an OP using the OP Endpoint URL. The establishment of an association session between the RP and the OP Endpoint URL is optional. It allows optimization of the traffic processing between both nodes.

The RP sends an Association Session Request to the OP Endpoint URL. This message contains the parameter defined in [8]. The association type may be of type HMAC-SHA1 or of HMAC-SHA256. The openid:session\_type may be set to either no-encryption, DH\_SHA1, or DH-SHA256.

The OP answers with an Association Session Response. The assoc\_handle is the association handle that is used as a key to refer to this association in the subsequent messages. For optimization purposes the RP may insert the B-TID in this field as a 255 character string. The expires\_in field should be populated with the key lifetime of the B-TID, represented in an integer in base 10 ASCII.

## 4.5.3 Assertions

### 4.5.3.1 Positive Assertions

If an authorized end user wishes to complete the authentication, then the OP should send a positive assertion to the RP. This message is encoded using Section 17 of [16], send as HTTP Requests (GET or POST) and contain the openid:ns and openid.mode fields. The message may contain the OP-local identifier e.g. B-TID, MSISDN in the opened.identity field. Note that the end user may choose to use an OP-Local Identifier as a claimed identifier, for the GBA-OpenID interworking the B-TID or the MSISDN may be used. The MSISDN might be easier for the user from the usability point of view, but on the other hand the B-TID would provide a better privacy.

If the MSISDN or the B-TID is used in the claimed identifier field, then the same value should be used in the openid.identity field.

### 4.5.3.2 Negative Assertions

Negative assertions are sent by the OP to the RP according to [8], if the OP is unable to identify the end user or the end user does not or cannot approve the authentication request. This message is encoded using Section 17 of [16], send as HTTP Requests (GET or POST) and contain the openid:ns and openid.mode fields.. One cause might be that the user may wish to explicitly terminate an ongoing session with his OpenID Provider or to abort a starting one.

Also, it might be possible that the operator may wish to terminate to support for OpenID usage for a particular user. This could be done by setting the USS by populating the authorization flag in TS 29.109 [7] accordingly, but this may not work for ongoing sessions. Alternatively, an explicit message could be send to the OpenID provider informing him about the termination of the support for OpenID usage for a particular user or cancellation of a particular session or credentials.

## 4.6 Use of GUSS and USS for OpenID

The USS may contain an authorization flag for the OpenID service. The OP may request the USS from the BSF and retrieve this authorization flag from the received USS as specified in TS 29.109 [7].

Alternatively, the OP may have a local authorization information for individual user"s. Conflicts between those policies should be avoided. If the OP is under MNO control then the MNO should decide where the authorization information is to be stored. If the OP is not under MNO control, the MNO and the OP should agree in their service agreement, where the authorization information should be kept or if they are combined with a logical AND.

NOTE: The MNO can always prevent the usage of GBA by not handing out the NAF keys.

The USS may contain the OpenID User Supplied Identifier in the user identities field. The GUSS or OpenID specific USS may also contain further identity information to be used together with the OpenID Attribute Exchange service extension [9]. This extension provides a mechanism for moving identity related information between sites. This kind of specific extension may be done in a proprietary manner or as part of an interworking customization.

## Annex A (informative): Example for Charging via IdP

A service providing node (RP) in the OpenID interworking scenario may not necessarily want to support Diameter or RADIUS and underlying protocols. On the other hand, those services might wish to have the possibility for easy billing via the operators (if the operator offers this possibility). The RP most likely supports web service, hence we give an example how the RP can send the needed information to a suitable operator node (e.g. IdP if hosted by the operator, but that depends on the contractual agreements and the operator network topology) in the body of a web service message. Below are the web service versions of the Credit Control Request and Credit Control Answer messages (taken from [15]).

The receiving node in the operator network needs to extract the values of the web service fields and put them into the diameter fields of the same name. It adds the Diameter header data and the Diameter session id. For the web service based CCA the converse process has to take place. When receiving the CCA, the node, needs to extract the session-Id and determines the corresponding RP (i.e. when doing the conversion web service CCR to CCR conversion, he has to store this pair). The conversion node has also to store the token in connection with the session-id.

The Service-Context-Id in the CCR and web serviced based CCR should contain information about the RP to avoid errors in the sender checking. In the GBA based case the NAF-ID of the protocol conversion node will be placed in the Origin-Host in the CCR and web service CCR. The Service-Parameter-Info element in the web service CCA may be used and contain a token to enable the RP to recognize the corresponding answer to the request later on, this would not be needed for CCA (since we there don't have an intermediary). In the all the messages the Auth-Application-Id element contains the OpenId identifier for the RP.

The RP in most cases does not have the subscription information. If the node taking care of the conversion has the subscription information i.e. an identity recognizable by the charging responsible network node, then he places it in the Subscription-Id field.

Below is an actual example of a potential web service based CCA and CCR:

```
<?xml version="1.0" encoding="UTF-8"?>
<wsdl:definitions name="CCService"
  targetNamespace="urn:3gpp:IdM:CCService:2009-10"
  xmlns:typens="urn:3gpp:IdM:CCService:2009-10"
  xmlns:wsdl="http://schemas.xmlsoap.org/wsdl/"
  xmlns:soap="http://schemas.xmlsoap.org/wsdl/soap/"
  xmlns:xsd="http://www.w3.org/2001/XMLSchema"
  xmlns:soapenc="http://schemas.xmlsoap.org/soap/encoding/">
  <wsdl:types>
    <xsd:schema targetNamespace="urn:3gpp:IdM:CCService:2009-10">
      <!-- Extension element definition -->
      <xsd:complexType name="tExtension">
        <xsd:sequence>
          <xsd:any processContents="lax" minOccurs="0" maxOccurs="unbounded"/>
        </xsd:sequence>
      </xsd:complexType>
      <!-- Request WS Credit Control Request parameter definitions -->
      <xsd:element name="requestWSCCRInfo">
        <xsd:complexType>
          <xsd:sequence>
            <xsd:element name="Origin-Host" type="xsd:string"/>
            <xsd:element name="Origin-Realm" type="xsd:base64Binary"/>
            <xsd:element name="Destination-Realm" type="xsd:string"/>
            <xsd:element name="Auth-Application-Id" type="xsd:string"/>
            <xsd:element name="Service-Context-Id" type="xsd:string"/>
            <xsd:element name="CC-Request-Type" type="xsd:integer"/>
            <xsd:element name="CC-Request-Number" type="xsd:integer"/>
            <xsd:element name="Destination-Host" type="xsd:string"/>
          </xsd:sequence>
        </xsd:complexType>
      </xsd:element>
    </xsd:schema>
  </wsdl:types>
</wsdl:definitions>
```

```

<xsd:element name="User-Name" type="xsd:string"/>
<xsd:element name="CC-Sub-Session-Id" type="base64Binary"/>
<xsd:element name="Acct-Multi-Session-Id" type="xsd:string"/>
<xsd:element name="Origin-State-Id" type="xsd:integer"/>
<xsd:element name="Event-Timestamp" type="xsd:dateTime"/>
<xsd:element name="Subscription-Id" type="xsd:string" minOccurs='0'/>
<xsd:element name="Service-Identifier" type="xsd:string"/>
<xsd:element name="Termination-Cause" type="xsd:string"/>
<xsd:element name="Requested-Service-Unit" type="xsd:string"/>
<xsd:element name="Requested-Action" type="xsd:string"/>
<xsd:element name="Used-Service-Unit" type="xsd:string"/>
<xsd:element name="Requested-Service-Unit" type="xsd:string" minOccurs='0'/>
<xsd:element name="Multiple-Services-Indicator" type="xsd:string"/>
<xsd:element name="Multiple-Service-Credit-Control" type="xsd:string" minOccurs='0'/>
<xsd:element name="Service-Parameter-Info" type="xsd:string" minOccurs='0'/>
<xsd:element name="CC-Correlation-Id" type="xsd:string"/>
<xsd:element name="User-Equipment-Info" type="xsd:string"/>
<xsd:element name="Proxy-Info" type="xsd:string" minOccurs='0'/>
<xsd:element name="Route-Record" type="xsd:string" minOccurs='0'/>
<xsd:element name="AVP" type="xsd:string" minOccurs='0'/>

```

```

</xsd:sequence>
</xsd:complexType>
</xsd:element>

```

```

<!-- Request WS Credit Control Answer parameter definitions -->
<xsd:element name="requestWSCCAInfo">
  <xsd:complexType>

```

```

  <xsd:sequence>
    <xsd:element name="Result-Code" type="xsd:integer"/>
    <xsd:element name="Origin-Host" type="xsd:string"/>
    <xsd:element name="Origin-Realm" type="xsd:base64Binary"/>
    <xsd:element name="Auth-Application-Id" type="xsd:string"/>
    <xsd:element name="CC-Request-Type" type="xsd:integer"/>
    <xsd:element name="CC-Request-Number" type="xsd:integer"/>
    <xsd:element name="User-Name" type="xsd:string"/>
    <xsd:element name="CC-Session-Failover" type="integer"/>
    <xsd:element name="CC-Sub-Session-Id" type="base64Binary"/>
    <xsd:element name="Acct-Multi-Session-Id" type="xsd:string"/>
    <xsd:element name="Origin-State-Id" type="xsd:integer"/>
    <xsd:element name="Event-Timestamp" type="xsd:dateTime"/>
    <xsd:element name="Granted-Service-Unit" type="xsd:string"/>
    <xsd:element name="Multiple-Service-Credit-Control" type="xsd:string" minOccurs='0'/>
    <xsd:element name="Service-Parameter-Info" type="xsd:string" minOccurs='0'/>
    <xsd:element name="Cost-Information" type="xsd:string"/>
    <xsd:element name="Final-Unit-Indication" type="xsd:string"/>
    <xsd:element name="Check-Balance-Result" type="xsd:integer"/>
    <xsd:element name="Credit-Control-Failure-Handling" type="xsd:integer"/>
    <xsd:element name="Direct-Debiting-Failure-Handling" type="xsd:string"/>
    <xsd:element name="Validity-Time" type="xsd:dateTime"/>
    <xsd:element name="Redirect-Host" type="xsd:string" minOccurs='0'/>
    <xsd:element name="Redirect-Host-Usage" type="xsd:integer"/>
    <xsd:element name="Redirect-Max-Cache-Time" type="xsd:string"/>
    <xsd:element name="Proxy-Info" type="xsd:string" minOccurs='0'/>
    <xsd:element name="Route-Record" type="xsd:string" minOccurs='0'/>
    <xsd:element name="Failed-AVP" type="xsd:string" minOccurs='0'/>
    <xsd:element name="AVP" type="xsd:string" minOccurs='0'/>
  </xsd:sequence>

```

```

  </xsd:complexType>
</xsd:element>

```

```

<!-- Request WS Credit Control Requestinfo fault parameter definitions -->
<xsd:element name="requestWSCCRInfoFault">
  <xsd:complexType>
    <xsd:sequence>
      <xsd:element name="errorCode" type="xsd:integer"/>
      <xsd:element name="errorText" type="xsd:string" minOccurs="0"/>
    </xsd:sequence>
  </xsd:complexType>
</xsd:element>

```

```

</xsd:schema>

```

```

</wsdl:types>

```

```

<wsdl:message name="requestWSCCRInfoMessage">
  <wsdl:part name="body" element="typens:requestWSCCRInfo"/>
</wsdl:message>

```

```
<wsdl:message name="requestWSCCAInfoMessage">
  <wsdl:part name="body" element="typens:requestWSCCAInfo"/>
</wsdl:message>

<wsdl:message name="requestWSCCRInfoFaultMessage">
  <wsdl:part name="body" element="typens:requestWSCCRInfoFault"/>
</wsdl:message>

<wsdl:portType name="CCServicePortType">
  <wsdl:operation name="requestWSCC">
    <wsdl:input message="typens:requestWSCCRInfoMessage"/>
    <wsdl:output message="typens:requestWSCCAInfoMessage"/>
    <wsdl:fault name="FaultName" message="typens:requestWSCCRInfoFaultMessage"/>
  </wsdl:operation>
</wsdl:portType>

<wsdl:binding name="CCServiceBinding" type="typens:CCServicePortType">
  <soap:binding style="document" transport="http://schemas.xmlsoap.org/soap/http"/>
  <wsdl:operation name="requestWSCCRInfo">
    <soap:operation soapAction="urn:3gpp:IdM:CCServiceAction:2009-10"/>
    <wsdl:input>
      <soap:body use="literal"/>
    </wsdl:input>
    <wsdl:output>
      <soap:body use="literal"/>
    </wsdl:output>
    <wsdl:fault name="FaultName">
      <soap:fault name="FaultName" use="literal"/>
    </wsdl:fault>
  </wsdl:operation>
</wsdl:binding>

<wsdl:service name="CCService">
  <wsdl:port name="CCServicePort" binding="typens:CCServiceBinding">
    <!-- add SOAP address location URI below -->
    <soap:address location="http://add.here.uri.to/CCService"/>
  </wsdl:port>
</wsdl:service>
</wsdl:definitions>
```

NOTE: Some of the CCA and CCR message fields are of type grouped. The data is specified as a sequence of AVPs, hence the string type is used for the conversion of those. The message from the mobile network to the service provider might alternatively concentrate several diameter events into an ASN.1 record and converting this into XML. The service can not utilize that method in the opposite direction.



## Annex B: Change history

Change history							
Date	TSG #	TSG Doc.	CR	Rev	Subject/Comment	Old	New
2009-09	SA#45	SP-090529	--	--	Presentation to SA for Information	0.2.0	1.0.0
2009-12	SA#46	SP-090827			Presentation to SA for Approval	1.1.0	2.0.0
2009-12	--	--	--	--	Publication of SA-approved version	2.0.0	9.0.0
2010-04	SA#47	SP-100096	003	-	Coding clarification of Annex	9.0.0	9.1.0
2010-04	SA#47	SP-100096	006	-	Clarification of USS description in OpenID - GAA interworking	9.0.0	9.1.0
2010-04	SA#47	SP-100096	008	-	Adding missing step for OpenID Authentication	9.0.0	9.1.0
2010-04	SA#47	SP-100096	009	-	Correction of reference	9.0.0	9.1.0
2010-04	SA#47	SP-100096	005	1	Restructuring and corrections to split terminal case	9.0.0	9.1.0
2010-04	SA#47	SP-100096	004	1	Correction of split terminal clause structure	9.0.0	9.1.0
2010-04	SA#47	SP-100096	007	1	Clarification of HTTPS usage in NAF and OpenIDP co-location	9.0.0	9.1.0
2010-06	SA#48	SP-100381	011	3	Correction of split terminal scenario 1, 2, 3	9.1.0	9.2.0
2010-10	SA#49	SP-100476	015	1	Unification of TLS and certificate references in TS 33.222 with TS 33.310	9.2.0	9.3.0
2011-03	-	-	-	-	Update to Rel-10 version (MCC)	9.3.0	10.0.0
2011-06	SA#52	SP-110266	020	1	Relationship of identities in GBA OpenID interworking	10.0.0	10.1.0
2011-06	SA#52	SP-110262	018	-	Correction of UA security protocol identifier in GBA - OpenID interworking	10.0.0	10.1.0
2012-09	-	-	-	-	Update to Rel-11 version (MCC)	10.1.0	<b>11.0.0</b>
2014-09	-	-	-	-	Update to Rel-12 version (MCC)	11.0.0	<b>12.0.0</b>

---

## History

<b>Document history</b>		
V12.0.0	October 2014	Publication