



**Universal Mobile Telecommunications System (UMTS);
LTE;
Review of dedicated 3GPP UICC features (Red_UCe)
(3GPP TR 31.901 version 13.0.0 Release 13)**



Reference

DTR/TSGC-0631901vd00

Keywords

LTE, UMTS

ETSI

650 Route des Lucioles
F-06921 Sophia Antipolis Cedex - FRANCE

Tel.: +33 4 92 94 42 00 Fax: +33 4 93 65 47 16

Siret N° 348 623 562 00017 - NAF 742 C
Association à but non lucratif enregistrée à la
Sous-Préfecture de Grasse (06) N° 7803/88

Important notice

The present document can be downloaded from:
<http://www.etsi.org/standards-search>

The present document may be made available in electronic versions and/or in print. The content of any electronic and/or print versions of the present document shall not be modified without the prior written authorization of ETSI. In case of any existing or perceived difference in contents between such versions and/or in print, the only prevailing document is the print of the Portable Document Format (PDF) version kept on a specific network drive within ETSI Secretariat.

Users of the present document should be aware that the document may be subject to revision or change of status. Information on the current status of this and other ETSI documents is available at
<http://portal.etsi.org/tb/status/status.asp>

If you find errors in the present document, please send your comment to one of the following services:
<https://portal.etsi.org/People/CommitteeSupportStaff.aspx>

Copyright Notification

No part may be reproduced or utilized in any form or by any means, electronic or mechanical, including photocopying and microfilm except as authorized by written permission of ETSI.

The content of the PDF version shall not be modified without the written authorization of ETSI.
The copyright and the foregoing restriction extend to reproduction in all media.

© European Telecommunications Standards Institute 2016.
All rights reserved.

DECT™, **PLUGTESTS™**, **UMTS™** and the ETSI logo are Trade Marks of ETSI registered for the benefit of its Members.
3GPP™ and **LTE™** are Trade Marks of ETSI registered for the benefit of its Members and of the 3GPP Organizational Partners.
GSM® and the GSM logo are Trade Marks registered and owned by the GSM Association.

Intellectual Property Rights

IPRs essential or potentially essential to the present document may have been declared to ETSI. The information pertaining to these essential IPRs, if any, is publicly available for **ETSI members and non-members**, and can be found in ETSI SR 000 314: *"Intellectual Property Rights (IPRs); Essential, or potentially Essential, IPRs notified to ETSI in respect of ETSI standards"*, which is available from the ETSI Secretariat. Latest updates are available on the ETSI Web server (<https://ipr.etsi.org>).

Pursuant to the ETSI IPR Policy, no investigation, including IPR searches, has been carried out by ETSI. No guarantee can be given as to the existence of other IPRs not referenced in ETSI SR 000 314 (or the updates on the ETSI Web server) which are, or may be, or may become, essential to the present document.

Foreword

This Technical Report (TR) has been produced by ETSI 3rd Generation Partnership Project (3GPP).

The present document may refer to technical specifications or reports using their 3GPP identities, UMTS identities or GSM identities. These should be interpreted as being references to the corresponding ETSI deliverables.

The cross reference between GSM, UMTS, 3GPP and ETSI identities can be found under <http://webapp.etsi.org/key/queryform.asp>.

Modal verbs terminology

In the present document "**shall**", "**shall not**", "**should**", "**should not**", "**may**", "**need not**", "**will**", "**will not**", "**can**" and "**cannot**" are to be interpreted as described in clause 3.2 of the [ETSI Drafting Rules](#) (Verbal forms for the expression of provisions).

"**must**" and "**must not**" are **NOT** allowed in ETSI deliverables except when used in direct citation.

Contents

Intellectual Property Rights	2
Foreword.....	2
Modal verbs terminology.....	2
Foreword.....	6
1 Scope	7
2 References	7
3 Definitions, and abbreviations.....	7
3.1 Definitions	7
3.2 Abbreviations	8
4 Review of USIM, ISIM and USAT features	8
4.1 Background	8
4.2 Local Phonebook.....	8
4.2.1 Description.....	8
4.2.2 Input from other groups and bodies	9
4.2.2.1 GCF CAG	9
4.2.2.1.1 Operator usage.....	9
4.2.2.1.2 Feedback.....	9
4.2.2.2 PTCRB	9
4.2.3 Discussion of Feature Value	9
4.2.3.1 General	9
4.2.3.2 Recommendation	9
4.2.4 Relevant Core Specifications	10
4.2.5 CT6 or RAN5 Test Case	10
4.2.6 GCF or PTCRB Certification.....	10
4.3 Support of Usage of MMS related data stored on the USIM.....	10
4.3.1 Description.....	10
4.3.2 Input from other groups and bodies	11
4.3.2.1 GCF CAG	11
4.3.2.1.1 Operator usage.....	11
4.3.2.1.2 Feedback.....	11
4.3.2.2 PTCRB	11
4.3.3 Discussion of Feature Value	11
4.3.3.1 General	11
4.3.3.2 Recommendation	11
4.3.4 Relevant Core Specifications	11
4.3.5 CT6 or RAN5 Test Case	12
4.3.6 GCF or PTCRB Certification.....	12
4.4 Launch Browser	12
4.4.1 Description.....	12
4.4.2 Input from other groups and bodies	12
4.4.2.1 GCF CAG	12
4.4.2.1.1 Operator usage.....	12
4.4.2.1.2 Feedback.....	12
4.4.2.2 PTCRB	12
4.4.3 Discussion of Feature Value	13
4.4.3.1 General	13
4.4.3.2 Recommendation	13
4.4.4 Relevant Core Specifications	13
4.4.5 CT6 or RAN5 Test Case	13
4.4.6 GCF or PTCRB Certification.....	14
4.5 Support of ACL.....	14
4.5.1 Description.....	14
4.5.2 Input from other groups and bodies	14

4.5.2.1	GCF CAG	14
4.5.2.1.1	Operator usage.....	14
4.5.2.1.2	Feedback.....	14
4.5.2.2	PTCRB	14
4.5.3	Discussion of Feature Value	15
4.5.4	Relevant Core Specifications.....	15
4.5.5	CT6 or RAN5 Test Case	15
4.5.6	GCF or PTCRB Certification.....	16
4.6	Alpha Identifier in REFRESH command	16
4.6.1	Description.....	16
4.6.2	Input from other groups and bodies	16
4.6.2.1	GCF CAG	16
4.6.2.1.1	Operator usage.....	16
4.6.2.1.2	Feedback.....	16
4.6.2.2	PTCRB	16
4.6.3	Discussion of Feature Value	16
4.6.4	Relevant Core Specifications.....	17
4.6.5	CT6 or RAN5 Test Case	17
4.6.6	GCF or PTCRB Certification.....	18
4.7	Event: Language Selection	18
4.7.1	Description.....	18
4.7.2	Input from other groups and bodies	18
4.7.2.1	GCF CAG	18
4.7.2.1.1	Operator usage.....	18
4.7.2.1.2	Feedback.....	18
4.7.2.2	PTCRB	18
4.7.3	Discussion of Feature Value	18
4.7.4	Relevant Core Specifications.....	19
4.7.5	CT6 or RAN5 Test Case	19
4.7.6	GCF or PTCRB Certification.....	19
4.8	Event Network Search Mode Change	19
4.8.1	Description.....	19
4.8.2	Input from other groups and bodies	20
4.8.2.1	GCF CAG	20
4.8.2.1.1	Operator usage.....	20
4.8.2.1.2	Feedback.....	20
4.8.2.2	PTCRB	20
4.8.3	Discussion of Feature Value	20
4.8.4	Relevant Core Specifications.....	21
4.8.5	CT6 or RAN5 Test Case	21
4.8.6	GCF or PTCRB Certification.....	21
4.9	Provide Local Information (Language)	21
4.9.1	Description.....	21
4.9.2	Input from other groups and bodies	21
4.9.2.1	GCF CAG	21
4.9.2.1.1	Operator usage.....	21
4.9.2.1.2	Feedback.....	21
4.9.2.2	PTCRB	21
4.9.3	Discussion of Feature Value	22
4.9.4	Relevant Core Specifications.....	22
4.9.5	CT6 or RAN5 Test Case	22
4.9.6	GCF or PTCRB Certification.....	23
4.10	Provide Local Information (search mode change).....	23
4.10.1	Description.....	23
4.10.2	Input from other groups and bodies	23
4.10.2.1	GCF CAG	23
4.10.2.1.1	Operator usage.....	23
4.10.2.1.2	Feedback.....	23
4.10.2.2	PTCRB	23
4.10.3	Discussion of Feature Value	23
4.10.4	Relevant Core Specifications.....	24
4.10.5	CT6 or RAN5 Test Case	24

4.10.6	GCF or PTCRB Certification.....	24
4.11	Language Notification.....	24
4.11.1	Description.....	24
4.11.2	Input from other groups and bodies	24
4.11.2.1	GCF CAG	24
4.11.2.1.1	Operator usage.....	24
4.11.2.1.2	Feedback.....	24
4.11.2.2	PTCRB	25
4.11.3	Discussion of Feature Value	25
4.11.4	Relevant Core Specifications	25
4.11.5	CT6 or RAN5 Test Case	25
4.11.6	GCF or PTCRB Certification.....	26
5	Conclusions and Recommendations.....	26
Annex A (informative): Change History		27
History		28

Foreword

This Technical Report has been produced by the 3rd Generation Partnership Project (3GPP).

The contents of the present document are subject to continuing work within the TSG and may change following formal TSG approval. Should the TSG modify the contents of the present document, it will be re-released by the TSG with an identifying change of release date and an increase in version number as follows:

Version x.y.z

where:

- x the first digit:
 - 1 presented to TSG for information;
 - 2 presented to TSG for approval;
 - 3 or greater indicates TSG approved document under change control.
- y the second digit is incremented for all changes of substance, i.e. technical enhancements, corrections, updates, etc.
- z the third digit is incremented when editorial only changes have been incorporated in the document.

1 Scope

The present document presents a review of the USIM, ISIM and the related Toolkit aspects (respectively found in TS 31.102 [3], TS 31.103 [4] and TS 31.111 [5]) features and their mandatory/optional support in the light of actual use or demand in the field is to be conducted. The technical report documents the justification for the support of features identified as not being implemented or required (e.g. from SA1 requirements). When a common understanding is reached about a potential need for a modification of the required support of a feature, it will be listed for further consideration by CT6. Should any normative work be derived from the content of the study, it will be carried out as part of a separate work item.

2 References

The following documents contain provisions which, through reference in this text, constitute provisions of the present document.

- References are either specific (identified by date of publication, edition number, version number, etc.) or non-specific.
- For a specific reference, subsequent revisions do not apply.
- For a non-specific reference, the latest version applies. In the case of a reference to a 3GPP document (including a GSM document), a non-specific reference implicitly refers to the latest version of that document *in the same Release as the present document*.

- [1] 3GPP TR 21.905: "Vocabulary for 3GPP Specifications".
- [2] 3GPP TR 41.001: "GSM Release specifications".
- [3] 3GPP TS 31.102: "Characteristics of the Universal Subscriber Identity Module (USIM) application".
- [4] 3GPP TS 31.103: "Characteristics of the IP multimedia services identity module (ISIM) application".
- [5] 3GPP TS 31.111: "Universal Subscriber Identity Module (USIM) Application Toolkit (USAT)".
- [6] ETSI TS 102 223 V11.1.0: "Smart Cards; Card Application Toolkit".
- [7] 3GPP TS 21.111: "USIM and IC card requirements".
- [8] 3GPP TS 31.121: "Universal Subscriber Identity Module (USIM) application test specification".
- [9] 3GPP TS 22.140: "Multimedia Messaging Service (MMS)".
- [10] OMA-RD-MMS-V1 3-20110913-A: "MMS Requirements".
- [11] 3GPP TS 31.124: "Universal Subscriber Identity Module Application Toolkit (USAT) conformance test specification".
- [12] GSMA: "IMEI Allocation and Approval Process Version 7.0 31st October 2013".

3 Definitions, and abbreviations

3.1 Definitions

For the purposes of the present document, the terms and definitions given in ETSI TS 102 223 [6] clause 3.1 and TR 21.905 [1] apply.

3.2 Abbreviations

For the purposes of the present document, the terms and definitions given in ETSI TS 102 223 [6] clause 3.1 and TR 21.905 [1] apply.

ACL	Access Control List
GCF	Global Certification Forum
ISIM	IM Subscriber Identity Module
MMS	Multimedia Messaging Service
PTCRB	PCS Type Certification Review Board
USAT	USIM Application Toolkit
USIM	Universal Subscriber Identity Module

4 Review of USIM, ISIM and USAT features

4.1 Background

Claiming support for a given release of 3GPP translates into the requirement to support all the mandatory features specified for that release. This requirement is often found to be a superset of the requirements actually expressed by the customers for 3GPP devices. This relates in particular to some of the mandatory features specified for USIM, ISIM and the related Toolkit aspects (respectively found in TS 31.102 [3], TS 31.103 [4] and TS 31.111 [5]), as it appears that there is no intent to use some of those mandatory features in the field.

With a view to best address their customer's requirements, the ME manufacturers tailor their implementation to the actual requirements expressed and to their understanding of which features are found to be used in the field. The current set of CT6 specifications does not allow for such profiling of features.

The following sub-sections look at individual features and identify if industry based test cases exist in CT6, RAN5, GCF and PTCRB. Other feature value attributes are also considered for the feature. Based on this information a conclusion is drawn if the feature should be made mandatory or optional in the respective TS 31.102 [3], TS 31.103 [4] and TS 31.111 [5] specifications.

4.2 Local Phonebook

4.2.1 Description

A Phonebook is a repository to store information about telephone numbers, email addresses, groups etc. There are different options where and in which way to store one or several phonebooks. There is a possibility to store a global phonebook under the $DF_{TELECOM}$ which is accessible by all applications of a UICC (e.g. several USIMs, a SIM, a CSIM). In addition it is possible to have a USIM application specific phonebook that is stored within an ADF_{USIM} which is only accessible by the related USIM application. This is what is called a "Local Phonebook"

Phonebooks are described in 3GPP TS 31.102 [3]. Extract of the feature from 3GPP TS 31.102 [3] is described below.

Table 4.2.1-1: DF PHONEBOOK extract from 3GPP TS 31.102 [3]

4.4.2 Contents of files at the DF PHONEBOOK level

The EFs in the $DF_{PHONEBOOK}$ level contain phone book related features as required in TS 21.111 [1].

The UICC may contain a global phonebook, or application specific phonebooks, or both in parallel. When both phonebook types co-exist, they are independent and no data is shared. In this case, it shall be possible for the user to select which phonebook the user would like to access. To achieve this, the terminal shall support the global and the application specific phonebooks

4.2.2 Input from other groups and bodies

4.2.2.1 GCF CAG

4.2.2.1.1 Operator usage

The following text is quoted from document C6-130531.

"Local Phonebook" appears to be required by just 1 operator for possible future use, The other 5 network operators are currently not requiring this feature and UE manufacturers have difficulty implementing it because of OS limitations, chipset limitations, etc. Additionally, these features may slow down device boot and it is also confusing for the user to be presented with several phonebooks.

4.2.2.1.2 Feedback

The following text is quoted from document C6-130531.

Noting the feedback, CAG would like to suggest that CT6 may consider making the "Local Phonebook" feature OPTIONAL.

4.2.2.2 PTCRB

PTCRB responded in C6-140252. The following is quoted from document C6-140252.

Based on this review by the PTCRB operators we would like to state that we agree with the GCF CAG evaluation with one exception. Item 2 – "Support of usage of MMS related data stored on the USIM" is viewed as required based on feedback from one of our operator members and we therefore recommend this feature be set to mandatory.

4.2.3 Discussion of Feature Value

4.2.3.1 General

There can be numerous phone books accessible in a device:

- a) UICC based phone books
 - i) Global Phone Book; and
 - ii) Local Phone Book; and
- b) Device based phone books;
 - i) Application specific; and
 - ii) Device Specific .e.g. Contacts List.

The UICC phone books are distinct; the local phone book is only accessible to the USIM application as specified in TS 31.102 [3] while the Global Phone Book is accessible to all UICC applications. Adding in the complexity of device based phone books and the roll out of IMS based services that use ISIM as specified in TS 31.103 [4] it becomes even more complex to manage a phone book specific to the USIM application.

In addition Global Phone Book is already a mandatory feature.

4.2.3.2 Recommendation

It is proposed to make the support of the local phone book in the ME mandatory in Feature Phones as specified in [12] only in TS 31.102 [3] and ensure that when Local Phone Book is supported by the ME the test specification as defined in TS 31.121 [8] makes the testing of the feature mandatory.

4.2.4 Relevant Core Specifications

Stage 1 requirements are in 3GPP TS 21.111 [7].

Stage 3 requirements are in 3GPP TS 31.102 [3].

4.2.5 CT6 or RAN5 Test Case

3GPP TS 31.121 [8] defines the test case for Local Phonebook feature. Table A.1 from 3GPP TS 31.121 [8] indicates if the feature should be mandatory or optional.

Table 4.2.5-1: Table A.1 from 3GPP TS 31.121 [8]

Table A.1: Options			
Item	Option	Status	Mnemonic
8	Support of local phonebook	C004	O_Local_PB

C004 If (A.1/18 is supported) AND (terminal is implemented according to Rel-6 or later) then M, else O

4.2.6 GCF or PTCRB Certification

N/A

4.3 Support of Usage of MMS related data stored on the USIM

4.3.1 Description

MMS is described in 3GPP TS 22.140 [9] and [OMA-RD-MMS-V1 3-20110913-A.pdf](#) [10]. It is a feature that allows a user to send and receive messages that could contain text, voice, images, video etc. An extract of the requirements from 3GPP TS 22.140 [9] can be found below.

Table 4.3.1-1: MMS extract from 3GPP TS 22.140 [9]

5.1 Multimedia message management

.....

- Storage of MMS parameters

The USIM shall be able to store the following types of MMS related data:

- i) a number of sets of issuer configuration information to allow access to MMS services.

At least one of these sets of configuration information should be stored on the USIM by the issuer of the USIM.

The first issuer configuration information set is denoted as the default configuration set.

This configuration information shall only be configurable by the issuer of the USIM.

- ii) a number of sets of user configuration information to allow access to MMS services.

If more than one set of configuration information is present, it shall be possible for the user to select which set is used. If the user has not selected any of the configuration information sets, then the default set in the active USIM is used.

- iii) MMS notifications

iv) MMS user preferences

A terminal using a USIM [7] or a SIM [8] with these MMS parameters, shall by default use them and the related preferred bearer, to access to the MMS services.

NOTE 1: Terminal support of SIM and USIM in general is specified in 3GPP TS 22.101[1].

4.3.2 Input from other groups and bodies

4.3.2.1 GCF CAG

4.3.2.1.1 Operator usage

The following text is quoted from document C6-130531 and relates to the storage of MMS configuration parameters (i.e. UST service n°55) (not the "Multimedia Message Storage" feature i.e. UST service n°67).

No operator support has been reported/observed in the field for "Support of usage of MMS related data stored on the USIM" as the relevant parameters are typically stored in the device and not on the USIM.

4.3.2.1.2 Feedback

The following text is quoted from document C6-130531 and relates to the storage of MMS configuration parameters (i.e. UST service n°55) (not the "Multimedia Message Storage" feature i.e. UST service n°67).

CAG would like to kindly ask CT6 to consider making "Support of usage of MMS related data stored on the USIM" OPTIONAL.

4.3.2.2 PTCRB

PTCRB responded in C6-140252. The following is quoted from document C6-140252.

Based on this review by the PTCRB operators we would like to state that we agree with the GCF CAG evaluation with one exception. Item 2 – "Support of usage of MMS related data stored on the USIM" is viewed as required based on feedback from one of our operator members and we therefore recommend this feature be set to mandatory.

4.3.3 Discussion of Feature Value

4.3.3.1 General

MMS is a feature that is slowly being superseded by social networking and messaging applications. GCF has reported that no operator support has been reported or observed. In fact only one operator in PTCRB has indicated that support for the feature is required.

4.3.3.2 Recommendation

It is proposed that the related test cases defined in TS 31.121 [8] be made optional.

4.3.4 Relevant Core Specifications

Stage 1 is described in 3GPP TS 22.140 [9] and [OMA-RD-MMS-V1 3-20110913-A.pdf](#) [10].

Stage 3 requirements are in 3GPP TS 31.102 [3].

4.3.5 CT6 or RAN5 Test Case

3GPP TS 31.121 [8] defines the test case for "Support of usage of MMS related data stored on the USIM" feature. Table A.1 from 3GPP TS 31.121 [8] indicates if the feature should be mandatory or optional.

Table 4.3.5-1: Table A.1 from 3GPP TS 31.121 [8]

Table A.1: Options			
Item	Option	Status	Mnemonic
12	Support of usage of MMS related data stored on the USIM	C005	O_MMS_USIM_DATA

C005 If ((A.1/11 is NOT supported) OR (terminal is implemented according to R99)) then N/A else if terminal is implemented according to Rel-4 then O else M

4.3.6 GCF or PTCRB Certification

N/A

4.4 Launch Browser

4.4.1 Description

This command is used to request a browser inside a browser-enabled ME to interpret the content corresponding to a URL.

4.4.2 Input from other groups and bodies

4.4.2.1 GCF CAG

4.4.2.1.1 Operator usage

The following text is quoted from document C6-130531 and the "LAUNCH BROWSER event" is to be understood as the "LAUNCH BROWSER command".

For the LAUNCH BROWSER event only the usage of the URL parameter has been observed in the field.

Usage of the Browser termination event has not been observed in the field.

4.4.2.1.2 Feedback

The following text is quoted from document C6-130531.

CAG would like to kindly ask CT6 to take the above feedback into account and consider making support for the LAUNCH BROWSER fields other than "URL" and the support of Browser termination event OPTIONAL for all terminals regardless of terminal class, release and other capabilities.

4.4.2.2 PTCRB

PTCRB responded in C6-140252. The following is quoted from document C6-140252.

Based on this review by the PTCRB operators we would like to state that we agree with the GCF CAG evaluation with one exception. Item 2 – "Support of usage of MMS related data stored on the USIM" is viewed as required based on feedback from one of our operator members and we therefore recommend this feature be set to mandatory.

4.4.3 Discussion of Feature Value

4.4.3.1 General

Browsers are a lot more sophisticated these days. The LAUNCH BROWSER command and its parameters were originally intended to launch WAP based solutions ETSI TS 102 223 [6] has the URL as mandatory and the other fields as optional.

Extract of the message structure from ETSI TS 102 223 [6] is described below.

Table 4.3.5-1: Launch Browser command from ETSI TS 102 223 [8]

6.6.26 LAUNCH BROWSER				
Description	Clause	M/O	Min	Length
Proactive UICC command Tag	9.2	M	Y	1
Length (A+B+C+D+E+F1+F2+...+FN+G+H+I+J+K+L+M+N)	-	M	Y	1 or 2
Command details	8.6	M	Y	A
Device Identities	8.7	M	Y	B
Browser Identity	8.47	O	N	C
URL	8.48	M	Y	D
Bearer	8.49	O	N	E
Provisioning File Reference 1	8.50	O	N	F1
Provisioning File Reference 2	8.50	O	N	F2
...	8.50	O	N	Fx
Provisioning File Reference N	8.50	O	N	FN
Text String (Gateway/Proxy Identity)	8.15	O	N	G
Alpha identifier (user confirmation phase)	8.2	O	N	H
Icon identifier (user confirmation phase)	8.31	O	N	I
Text Attribute	8.72	C	N	J
Frame Identifier	8.80	O	N	K
Network Access Name	8.70	O	N	L
Text String (User login)	8.15	O	N	M
Text String (User password)	8.15	O	N	N

TS 31.124 [11] requires the ME to support numerous tests that require other parameters to be supported. Some of these parameters are for WAP based browsers. Most UEs don't support WAP-based browsers anymore.

4.4.3.2 Recommendation

It is proposed that the test cases to test the support of the optional parameters as listed in ETSI TS 102 223 [6] be made optional in TS 31.124 [11].

Editor's note: needs to be identified which of the optional parameters in the LAUNCH BROWSER command are specific to a non-WAP browser.

4.4.4 Relevant Core Specifications

Stage 3 requirements are in 3GPP TS 31.111 [5] however these are derived from ETSI TS 102 223 [6].

4.4.5 CT6 or RAN5 Test Case

3GPP TS 31.121 [8] defines the test case for Launch Browser feature. Table A.1 from 3GPP TS 31.121 [8] indicates if the feature should be mandatory or optional.

Table 4.4.5-1: Table A.1 from 3GPP TS 31.121 [8]

Table A.1: Options			
Item	Option	Status	Mnemonic
10	Class C: LAUNCH BROWSER	O	O_LB

In 3GPP TS 31.124 [11]:

Table E.1: TERMINAL PROFILE support				
Item	Terminal Profile	Release	Status	Mnemonic
42	Event: Browser Termination	R99	C212 AND C267 AND C268	PD_Browser_Term

4.4.6 GCF or PTCRB Certification

N/A

4.5 Support of ACL

4.5.1 Description

This EF_{ACL} contains the list of allowed APNs (Access Point Names). When the APN Control List service is enabled, the ME shall check that the entire APN of any PDP context is listed in EF_{ACL} before requesting this PDP context activation from the network. If the APN is not present in EF_{ACL}, the ME shall not request the corresponding PDP context activation from the network.

4.5.2 Input from other groups and bodies

4.5.2.1 GCF CAG

4.5.2.1.1 Operator usage

The following text is quoted from document C6-130531.

BEREC Guidelines on Roaming Regulation Draft "requires that domestic mobile providers shall enable their customers to access regulated voice, SMS and data roaming services provided as a bundle by any alternative roaming provider" [1]. "Support of ACL" (ACL=APN control list, APN=Access Point Name) is currently mandatory for terminals supporting E-UTRAN and optional for other terminals.

There is a concern that keeping this feature mandatory for E-UTRA terminals might interfere with **BEREC Guidelines on Roaming Regulation Draft** that "requires that domestic mobile providers shall enable their customers to access regulated voice, SMS and data roaming services provided as a bundle by any alternative roaming provider".

4.5.2.1.2 Feedback

The following text is quoted from document C6-130531.

CAG would like to kindly ask CT6 to take the above feedback into account and kindly consider making "Support of ACL" OPTIONAL for all terminals regardless of their radio capability.

4.5.2.2 PTCRB

PTCRB responded in C6-140252. The following is quoted from document C6-140252.

Based on this review by the PTCRB operators we would like to state that we agree with the GCF CAG evaluation with one exception. Item 2 – "Support of usage of MMS related data stored on the USIM" is viewed as required based on feedback from one of our operator members and we therefore recommend this feature be set to mandatory.

4.5.3 Discussion of Feature Value

As indicated by PTCRB and GCF there is no market requirement for support of testing EF_{ACL} . Furthermore 3GPP TS 31.102 [x] section 5.1.1.2 foresees that an ME may not support the ACL file as defined in section 5.3.14 of TS 31.102 [x].

Table 4.5.3-1: Extract from 3GPP TS 31.102 [x]

<p>5.1.1.2 USIM initialisation</p> <p>.....</p> <p>If ACL is enabled, an ME which does not support ACL shall not send any APN to the network.</p> <p>.....</p>
--

In addition 3GPP TS 31.121 [8] has test cases to test for an ME that does not support EF_{ACL} .

Table 4.5.3-2: Extract from 3GPP TS 31.121 [8]

<p>9.1.3 Access Point Name Control List handling for terminals not supporting ACL</p> <p>9.1.3.1 Definition and applicability</p> <p>This EF_{ACL} contains the list of allowed APNs (Access Point Names). When the APN Control List service is enabled, the ME shall check that the entire APN of any PDP context is listed in EF_{ACL} before requesting this PDP context activation from the network. If the APN is not present in EF_{ACL}, the ME shall not request the corresponding PDP context activation from the network.</p> <p>If ACL is enabled, an ME which does not support ACL shall not send any APN to the network.</p>
--

It is proposed that Table A.1 in 3GPP TS 31.121 [8] makes the support optional to be in alignment with core specification and the test cases within 3GPP TS 31.121 [8].

4.5.4 Relevant Core Specifications

Stage 3 requirements are in 3GPP TS 31.102 [3].

4.5.5 CT6 or RAN5 Test Case

3GPP TS 31.121 [8] defines the test case for Support of ACL. Table A.1 from 3GPP TS 31.121 [8] indicates if the feature should be mandatory or optional.

Table 4.5.5-1: Table A.1 from 3GPP TS 31.121 [8]

Table A.1: Options			
Item	Option	Status	Mnemonic
15	Support of ACL	C006	O_ACL

C006 If (A.1/20 is supported or A.1/21 is supported) then M else O

4.5.6 GCF or PTCRB Certification

N/A

4.6 Alpha Identifier in REFRESH command

4.6.1 Description

Is an indication that when provided in a REFRESH command identities to the ME if an indication should be given to the user or not. More complete description can be found in subclause 6.4.7 ETSI TS 102 223 [6].

4.6.2 Input from other groups and bodies

4.6.2.1 GCF CAG

4.6.2.1.1 Operator usage

No comments from GCF CAG.

4.6.2.1.2 Feedback

The following text is quoted from document C6-130531.

CAG would like to kindly ask CT6 to consider making "Alpha Identifier in REFRESH command supported by terminal" OPTIONAL for all terminals even if the terminal has a display capability.

4.6.2.2 PTCRB

PTCRB responded in C6-140252. The following is quoted from document C6-140252.

Based on this review by the PTCRB operators we would like to state that we agree with the GCF CAG evaluation with one exception. Item 2 – "Support of usage of MMS related data stored on the USIM" is viewed as required based on feedback from one of our operator members and we therefore recommend this feature be set to mandatory.

4.6.3 Discussion of Feature Value

As indicated by PTCRB and GCF there is no market requirement for support of testing alpha identifier. Furthermore ETSI TS 102 223 V11.1.0 [6] section 5.2 has an explicit bit (byte 20, bit b4) in the terminal profile, independent of a bit (byte 14, bit b6) to indicate No Display, to indicate if the ME support s alpha identifier optional in the ME i.e. the support of the alpha identifier in the REFRESH command is independent if a display is available or not.

Table 4.6.3-1: Extract from ETSI TS 102 223 V11.1.0 [6]

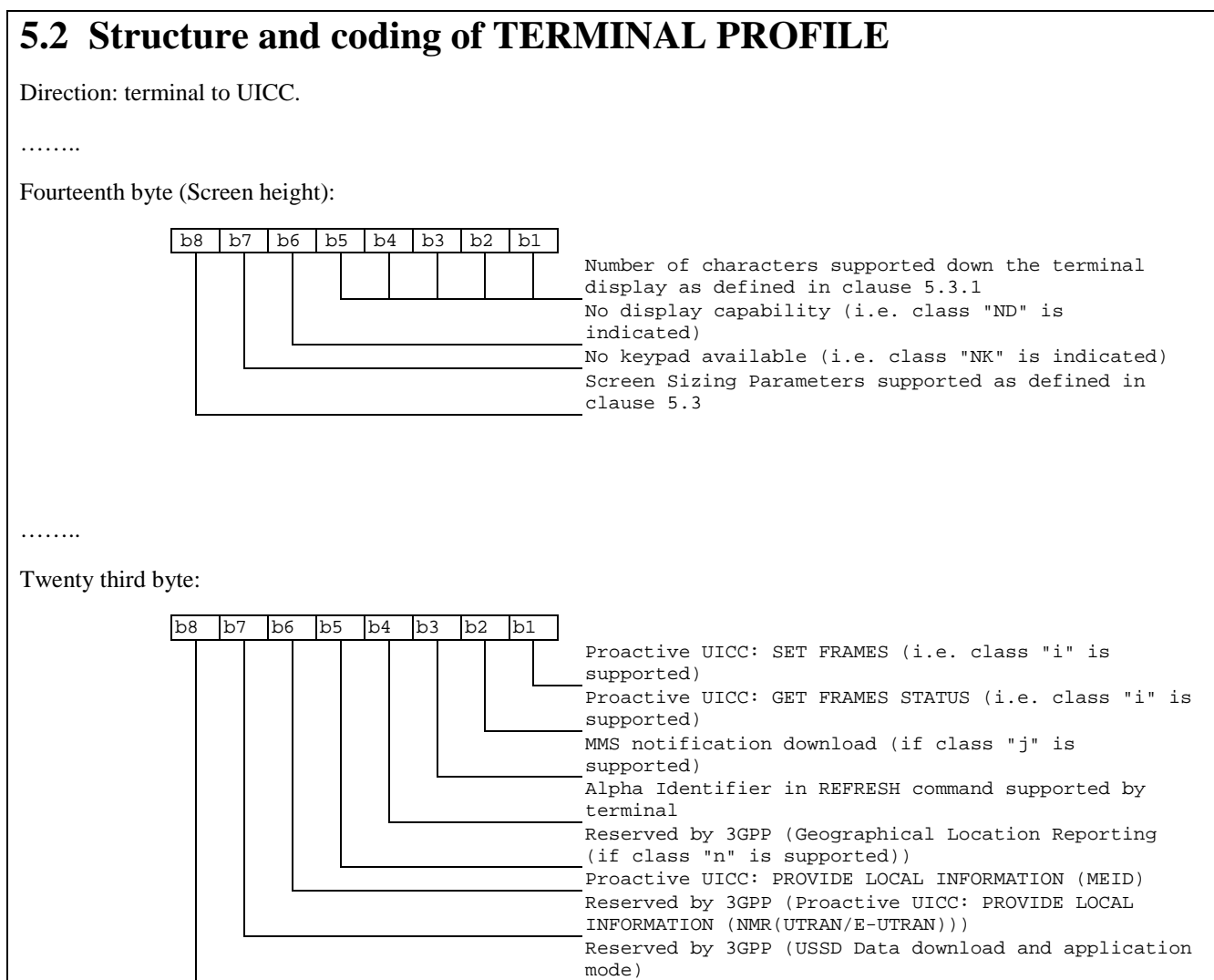

Align Table E.1 from 3GPP TS 31.124 [11] with ETSI TS 102 223 V11.1.0 [6] and remove the NOTE against condition C267 in 3GPP TS 31.124 [11].

4.6.4 Relevant Core Specifications

N/A

4.6.5 CT6 or RAN5 Test Case

3GPP TS 31.124 [11] defines the test case for Alpha Identifier in REFRESH command. Table E.1 from 3GPP TS 31.124 [11] indicates if the feature should be mandatory or optional.

Table 4.6.5-1: Table E.1 from 3GPP TS 31.124 [11]

Table E.1: TERMINAL PROFILE support				
Item	Terminal Profile	Release	Status	Mnemonic
180	Alpha Identifier in REFRESH command supported by terminal	Rel-7	C267	PD_Refresh_AlphaIdentifier

C267 IF A.1/84 THEN M ELSE O.1

NOTE: A.1/84 Terminal supports display capability

4.6.6 GCF or PTCRB Certification

N/A

4.7 Event: Language Selection

4.7.1 Description

Used by the UICC application to instruct the ME that if the language is changed on the ME that the ME shall inform the UICC of this event.

4.7.2 Input from other groups and bodies

4.7.2.1 GCF CAG

4.7.2.1.1 Operator usage

The following text is quoted from document C6-130531.

There is no or very little network operator support

4.7.2.1.2 Feedback

The following text is quoted from document C6-130531.

CAG would like to kindly ask CT6 to consider making the below features OPTIONAL.

4.7.2.2 PTCRB

PTCRB responded in C6-140252. The following is quoted from document C6-140252.

Based on this review by the PTCRB operators we would like to state that we agree with the GCF CAG evaluation with one exception. Item 2 – "Support of usage of MMS related data stored on the USIM" is viewed as required based on feedback from one of our operator members and we therefore recommend this feature be set to mandatory.

4.7.3 Discussion of Feature Value

As indicated by PTCRB and GCF there is no market requirement for support of Event: Language Selection. Furthermore ETSI TS 102 223 V11.1.0 [6] section 5.2 has an explicit bit (byte 6, bit b1) in the terminal profile, to indicate if Event: Language Selection, is supported or not by the ME.

Table 4.8.3-1: Extract from ETSI TS 102 223 V11.1.0 [6]

5.2 Structure and coding of TERMINAL PROFILE

Direction: terminal to UICC.

.....

Sixth byte (Event driven information extensions):

b8	b7	b6	b5	b4	b3	b2	b1
----	----	----	----	----	----	----	----

Event: Language selection

Event: Browser Termination

Event: Data available

Event: Channel status

Event: Access Technology Change

Event: Display parameters changed

Event: Local Connection

Event: Network Search Mode Change

Align Table E.1 from 3GPP TS 31.124 [11] with ETSI TS 102 223 V11.1.0 [6] and remove the NOTE and make the Status optional in 3GPP TS 31.124 [11].

4.7.4 Relevant Core Specifications

Stage 3 requirements are in 3GPP TS 31.111 [5] however these are derived from ETSI TS 102 223 [6].

4.7.5 CT6 or RAN5 Test Case

3GPP TS 31.124 [11] defines the test case for EVENT: LANGUAGE SELECTION event. Table E.1 from 3GPP TS 31.124 [11] indicates if the feature should be mandatory or optional.

Table 4.7.5-1: Table E.1 from 3GPP TS 31.124 [11]

Table E.1: TERMINAL PROFILE support				
Item	Terminal Profile	Release	Status	Mnemonic
41	Event: Language selection	R99	C271	PD_Lang_Select

C271 IF A.1/88 THEN M ELSE O.1

NOTE: A.1/88 Terminal supports multiple languages (If feature is implemented according to Rel-8 or later then O, else M.)

4.7.6 GCF or PTCRB Certification

N/A

4.8 Event Network Search Mode Change

4.8.1 Description

There are cases where toolkit applications need to know which Network Search Mode is selected by the user so it can issue specific roaming behaviour.

An application for roaming management can be deactivated when a user selects manual mode. When automatic mode is restored the application can be activated again.

The information can be queried from the ME using either EVENT DOWNLOAD or PROVIDE LOCAL INFORMATION commands.

4.8.2 Input from other groups and bodies

4.8.2.1 GCF CAG

4.8.2.1.1 Operator usage

The following text is quoted from document C6-130531.

There is no or very little network operator support

4.8.2.1.2 Feedback

The following text is quoted from document C6-130531.

CAG would like to kindly ask CT6 to consider making the below features OPTIONAL.

4.8.2.2 PTCRB

PTCRB responded in C6-140252. The following is quoted from document C6-140252.

Based on this review by the PTCRB operators we would like to state that we agree with the GCF CAG evaluation with one exception. Item 2 – "Support of usage of MMS related data stored on the USIM" is viewed as required based on feedback from one of our operator members and we therefore recommend this feature be set to mandatory.

4.8.3 Discussion of Feature Value

As indicated by PTCRB and GCF there is no market requirement for support of Event Network Search Mode Change. Furthermore ETSI TS 102 223 V11.1.0 [6] section 5.2 has an explicit bit (byte 6, bit b8) in the terminal profile to indicate Event Network Search Mode Change, is supported or not by the ME.

Table 4.8.3-1: Extract from ETSI TS 102 223 V11.1.0 [6]

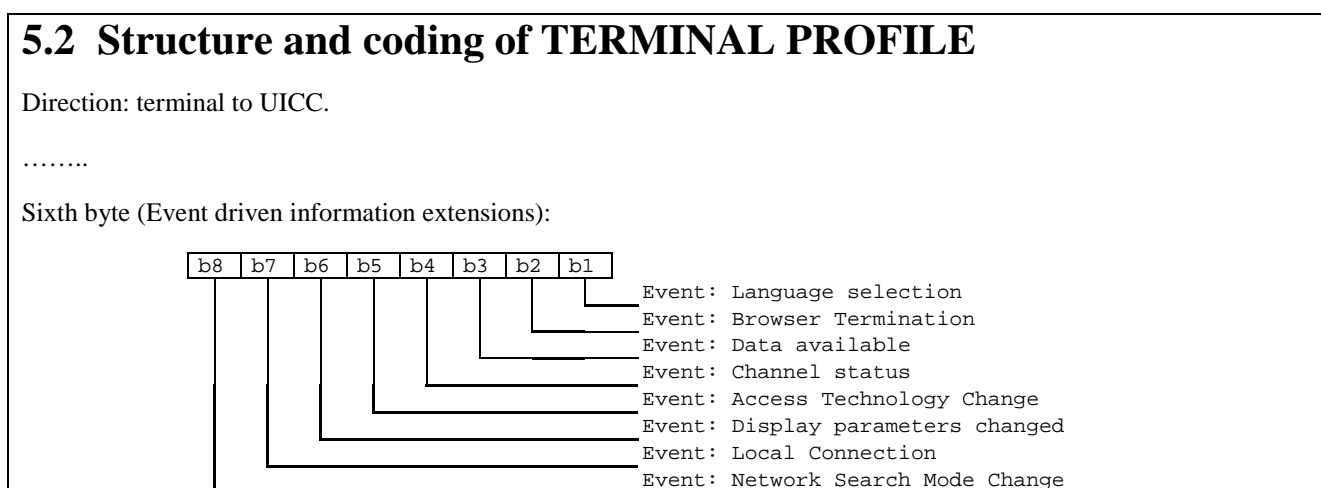

Align Table E.1 from 3GPP TS 31.124 [11] with ETSI TS 102 223 V11.1.0 [6] and make the Status optional in 3GPP TS 31.124 [11].

4.8.4 Relevant Core Specifications

Stage 3 requirements are in 3GPP TS 31.111 [5] however these are derived from ETSI TS 102 223 [6].

4.8.5 CT6 or RAN5 Test Case

3GPP TS 31.124 [11] defines the test case for EVENT: NETWORK SEARCH MODE CHANGE event. Table E.1 from 3GPP TS 31.124 [11] indicates if the feature should be mandatory or optional.

Table 4.8.5-1: Table E.1 from 3GPP TS 31.124 [11]

Table E.1: TERMINAL PROFILE support				
Item	Terminal Profile	Release	Status	Mnemonic
48	Event: Network Search Mode Change	Rel-6	M	PD_Evt_NSMC

4.8.6 GCF or PTCRB Certification

4.9 Provide Local Information (Language)

4.9.1 Description

Allows the UICC to request from the ME the current language being used.

4.9.2 Input from other groups and bodies

4.9.2.1 GCF CAG

4.9.2.1.1 Operator usage

The following text is quoted from document C6-130531.

There is no or very little network operator support

4.9.2.1.2 Feedback

The following text is quoted from document C6-130531.

CAG would like to kindly ask CT6 to consider making the below features OPTIONAL.

4.9.2.2 PTCRB

PTCRB responded in C6-140252. The following is quoted from document C6-140252.

Based on this review by the PTCRB operators we would like to state that we agree with the GCF CAG evaluation with one exception. Item 2 – "Support of usage of MMS related data stored on the USIM" is viewed as required based on feedback from one of our operator members and we therefore recommend this feature be set to mandatory.

4.9.3 Discussion of Feature Value

As indicated by PTCRB and GCF there is no market requirement for support of Provide Local Information (Language). Furthermore ETSI TS 102 223 V11.1.0 [6] section 5.2 has an explicit bit (byte 9, bit b4) in the terminal profile to indicate Provide Local Information (Language), is supported or not by the ME.

Table 4.9.3-1: Extract from ETSI TS 102 223 V11.1.0 [6]

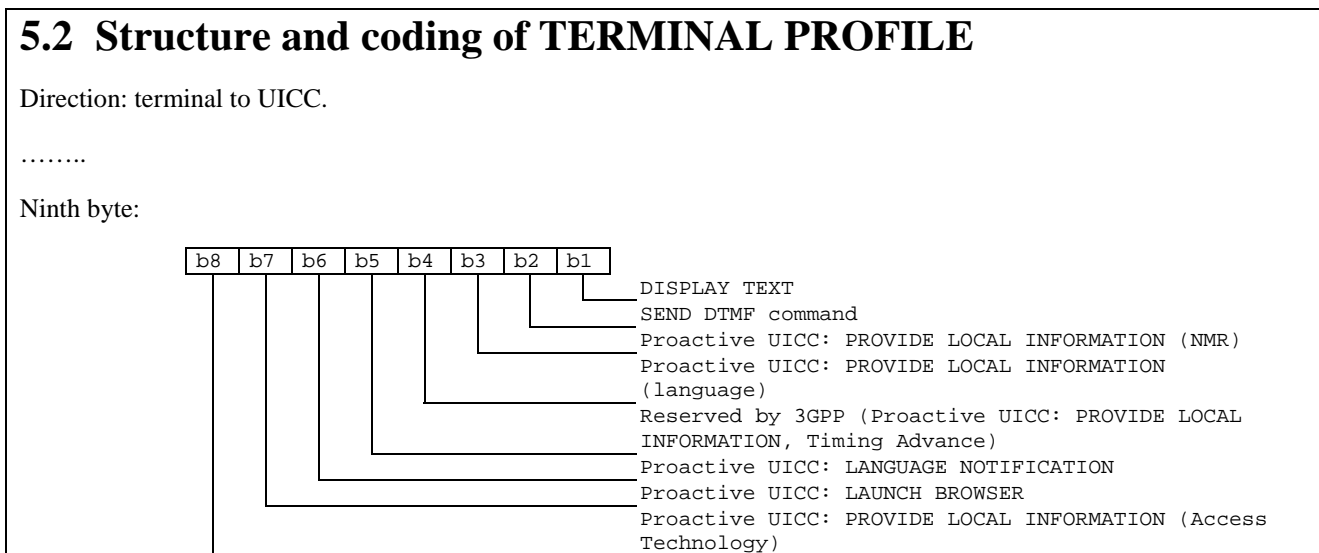

Align Table E.1 from 3GPP TS 31.124 [11] with ETSI TS 102 223 V11.1.0 [6] and make the Status optional in 3GPP TS 31.124 [11].

4.9.4 Relevant Core Specifications

Stage 3 requirements are in 3GPP TS 31.111 [5] however these are derived from ETSI TS 102 223 [6].

4.9.5 CT6 or RAN5 Test Case

3GPP TS 31.124 [11] defines the test case for PROVIDE LOCAL INFORMATION (language) command. Table E.1 from 3GPP TS 31.124 [11] indicates if the feature should be mandatory or optional.

Table 4.9.5-1: Table E.1 from 3GPP TS 31.124 [11]

Table E.1: TERMINAL PROFILE support				
Item	Terminal Profile	Release	Status	Mnemonic
68	PROVIDE LOCAL INFORMATION (language)	R99	M	PD_Provide_Local_LS

4.9.6 GCF or PTCRB Certification

4.10 Provide Local Information (search mode change)

4.10.1 Description

There are cases where toolkit applications need to know which Network Search Mode is selected by the user so it can issue specific roaming behaviour.

An application for roaming management can be deactivated when a user selects manual mode. When automatic mode is restored the application can be activated again.

The information can be queried from the ME using either EVENT DOWNLOAD or PROVIDE LOCAL INFORMATION commands.

4.10.2 Input from other groups and bodies

4.10.2.1 GCF CAG

4.10.2.1.1 Operator usage

The following text is quoted from document C6-130531.

There is no or very little network operator support

4.10.2.1.2 Feedback

The following text is quoted from document C6-130531.

CAG would like to kindly ask CT6 to consider making the below features OPTIONAL.

4.10.2.2 PTCRB

PTCRB responded in C6-140252. The following is quoted from document C6-140252.

Based on this review by the PTCRB operators we would like to state that we agree with the GCF CAG evaluation with one exception. Item 2 – "Support of usage of MMS related data stored on the USIM" is viewed as required based on feedback from one of our operator members and we therefore recommend this feature be set to mandatory.

4.10.3 Discussion of Feature Value

As indicated by PTCRB and GCF there is no market requirement for support of Provide Local Information (search mode change). Furthermore ETSI TS 102 223 V11.1.0 [6] section 5.2 has an explicit bit (byte 18, bit b8) in the terminal profile to indicate Provide Local Information (search mode change), is supported or not by the ME.

Table 4.10.3-1: Extract from ETSI TS 102 223 V11.1.0 [6]

5.2 Structure and coding of TERMINAL PROFILE							
Direction: terminal to UICC.							
.....							
Eighteenth byte:							
b8	b7	b6	b5	b4	b3	b2	b1
							Proactive UICC: DISPLAY TEXT (Variable Time out)
							Proactive UICC: GET INKEY (help is supported while waiting for immediate response or variable timeout)

											USB (Bearer Independent protocol supported bearers, class "e") Proactive UICC: GET INKEY (Variable Timeout) Proactive UICC: PROVIDE LOCAL INFORMATION (ESN) Reserved by 3GPP (Call control on GPRS) Proactive UICC: PROVIDE LOCAL INFORMATION (IMEISV) Proactive UICC: PROVIDE LOCAL INFORMATION (Search Mode change)
--	--	--	--	--	--	--	--	--	--	--	--

Align Table E.1 from 3GPP TS 31.124 [11] with ETSI TS 102 223 V11.1.0 [6] and make the Status optional in 3GPP TS 31.124 [11].

4.10.4 Relevant Core Specifications

Stage 3 requirements are in 3GPP TS 31.111 [5] however these are derived from ETSI TS 102 223 [6].

4.10.5 CT6 or RAN5 Test Case

3GPP TS 31.124 [11] defines the test case for PROVIDE LOCAL INFORMATION (search mode change) command. Table E.1 from 3GPP TS 31.124 [11] indicates if the feature should be mandatory or optional.

Table 4.10.5-1: Table E.1 from 3GPP TS 31.124 [11]

Table E.1: TERMINAL PROFILE support				
Item	Terminal Profile	Release	Status	Mnemonic
144	PROVIDE LOCAL INFORMATION (search mode change)	Rel-6	M	PD_Provide_Local_SMC

4.10.6 GCF or PTCRB Certification

N/A

4.11 Language Notification

4.11.1 Description

Language Notification command allows the UICC to inform the ME of the language that is currently being used for text strings within proactive commands or envelop commands. The use of it by the terminal is optional and one example given is it might allow the ME to pick a specific language for the ME MMI.

4.11.2 Input from other groups and bodies

4.11.2.1 GCF CAG

4.11.2.1.1 Operator usage

The following text is quoted from document C6-130531.

There is no or very little network operator support

4.11.2.1.2 Feedback

The following text is quoted from document C6-130531.

CAG would like to kindly ask CT6 to consider making the below features OPTIONAL.

4.11.2.2 PTCRB

PTCRB responded in C6-140252. The following is quoted from document C6-140252.

Based on this review by the PTCRB operators we would like to state that we agree with the GCF CAG evaluation with one exception. Item 2 – "Support of usage of MMS related data stored on the USIM" is viewed as required based on feedback from one of our operator members and we therefore recommend this feature be set to mandatory.

4.11.3 Discussion of Feature Value

As indicated by PTCRB and GCF there is no market requirement for support of Language Notification. Furthermore ETSI TS 102 223 V11.1.0 [6] section 5.2 has an explicit bit (byte 9, bit b6) in the terminal profile to indicate Event Language Notification, is supported or not by the ME.

Table 4.11.3-1: Extract from ETSI TS 102 223 V11.1.0 [6]

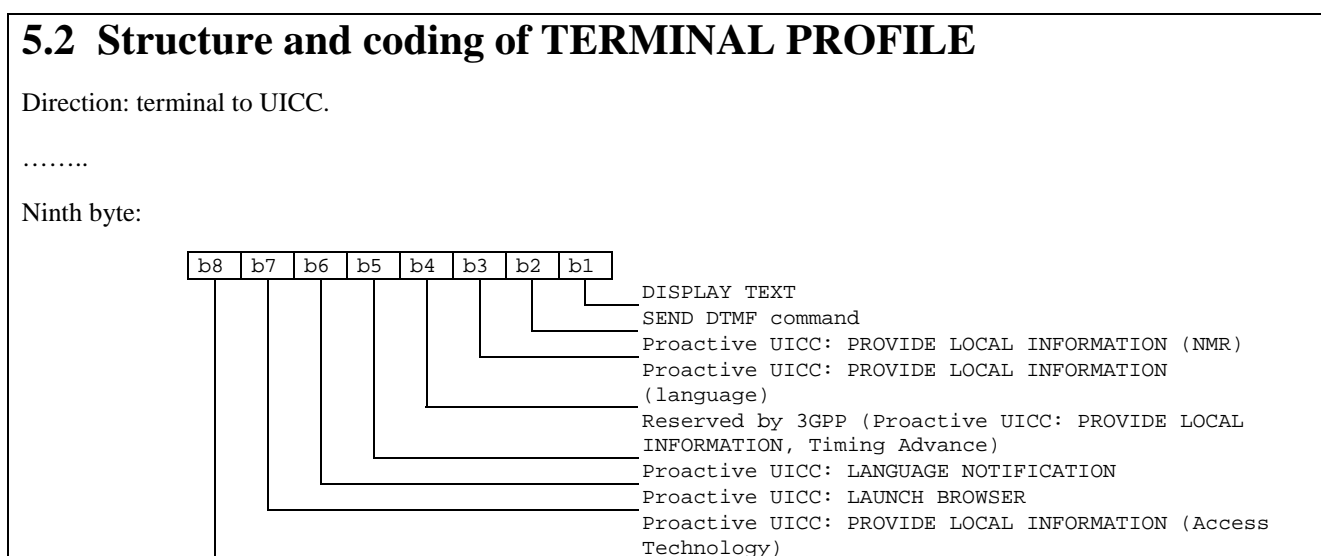

Align Table E.1 from 3GPP TS 31.124 [11] with ETSI TS 102 223 V11.1.0 [6] and make the Status optional in 3GPP TS 31.124 [11].

4.11.4 Relevant Core Specifications

Stage 3 requirements are in 3GPP TS 31.111 [5] however these are derived from ETSI TS 102 223 [6].

4.11.5 CT6 or RAN5 Test Case

3GPP TS 31.124 [11] defines the test case for LANGUAGE NOTIFICATION command. Table E.1 from 3GPP TS 31.124 [11] indicates if the feature should be mandatory or optional.

Table 4.11.5-1: Table E.1 from 3GPP TS 31.124 [11]

Table E.1: TERMINAL PROFILE support				
Item	Terminal Profile	Release	Status	Mnemonic
70	LANGUAGE NOTIFICATION	R99	C271	PD_Lang_Notif

4.11.6 GCF or PTCRB Certification

N/A

5 Conclusions and Recommendations

Implement the proposed changes as identified in each feature "Discussion of feature value" section.

Annex A (informative): Change History

Change history							
Date	TSG #	TSG Doc.	CR	Rev	Subject/Comment	Old	New
2014-12	CT-66	CP-140952	-	-	Approval		13.0.0

History

Document history		
V13.0.0	March 2016	Publication