

ETSI TR 129 949 V15.0.0 (2018-07)



**Universal Mobile Telecommunications System (UMTS);
LTE;
Study on technical aspects on roaming end-to-end scenarios
with Voice over LTE (VoLTE) IP Multimedia Subsystem (IMS)
and other networks
(3GPP TR 29.949 version 15.0.0 Release 15)**



Reference

RTR/TSGC-0329949vf00

Keywords

LTE,UMTS

ETSI

650 Route des Lucioles
F-06921 Sophia Antipolis Cedex - FRANCE

Tel.: +33 4 92 94 42 00 Fax: +33 4 93 65 47 16

Siret N° 348 623 562 00017 - NAF 742 C
Association à but non lucratif enregistrée à la
Sous-Préfecture de Grasse (06) N° 7803/88

Important notice

The present document can be downloaded from:

<http://www.etsi.org/standards-search>

The present document may be made available in electronic versions and/or in print. The content of any electronic and/or print versions of the present document shall not be modified without the prior written authorization of ETSI. In case of any existing or perceived difference in contents between such versions and/or in print, the only prevailing document is the print of the Portable Document Format (PDF) version kept on a specific network drive within ETSI Secretariat.

Users of the present document should be aware that the document may be subject to revision or change of status.

Information on the current status of this and other ETSI documents is available at

<https://portal.etsi.org/TB/ETSIDeliverableStatus.aspx>

If you find errors in the present document, please send your comment to one of the following services:

<https://portal.etsi.org/People/CommiteeSupportStaff.aspx>

Copyright Notification

No part may be reproduced or utilized in any form or by any means, electronic or mechanical, including photocopying and microfilm except as authorized by written permission of ETSI.

The content of the PDF version shall not be modified without the written authorization of ETSI.

The copyright and the foregoing restriction extend to reproduction in all media.

© ETSI 2018.

All rights reserved.

DECT™, **PLUGTESTS™**, **UMTS™** and the ETSI logo are trademarks of ETSI registered for the benefit of its Members.

3GPP™ and **LTE™** are trademarks of ETSI registered for the benefit of its Members and of the 3GPP Organizational Partners.

oneM2M logo is protected for the benefit of its Members.

GSM® and the GSM logo are trademarks registered and owned by the GSM Association.

Intellectual Property Rights

Essential patents

IPRs essential or potentially essential to normative deliverables may have been declared to ETSI. The information pertaining to these essential IPRs, if any, is publicly available for **ETSI members and non-members**, and can be found in ETSI SR 000 314: *"Intellectual Property Rights (IPRs); Essential, or potentially Essential, IPRs notified to ETSI in respect of ETSI standards"*, which is available from the ETSI Secretariat. Latest updates are available on the ETSI Web server (<https://ipr.etsi.org/>).

Pursuant to the ETSI IPR Policy, no investigation, including IPR searches, has been carried out by ETSI. No guarantee can be given as to the existence of other IPRs not referenced in ETSI SR 000 314 (or the updates on the ETSI Web server) which are, or may be, or may become, essential to the present document.

Trademarks

The present document may include trademarks and/or tradenames which are asserted and/or registered by their owners. ETSI claims no ownership of these except for any which are indicated as being the property of ETSI, and conveys no right to use or reproduce any trademark and/or tradename. Mention of those trademarks in the present document does not constitute an endorsement by ETSI of products, services or organizations associated with those trademarks.

Foreword

This Technical Report (TR) has been produced by ETSI 3rd Generation Partnership Project (3GPP).

The present document may refer to technical specifications or reports using their 3GPP identities, UMTS identities or GSM identities. These should be interpreted as being references to the corresponding ETSI deliverables.

The cross reference between GSM, UMTS, 3GPP and ETSI identities can be found under <http://webapp.etsi.org/key/queryform.asp>.

Modal verbs terminology

In the present document "**should**", "**should not**", "**may**", "**need not**", "**will**", "**will not**", "**can**" and "**cannot**" are to be interpreted as described in clause 3.2 of the [ETSI Drafting Rules](#) (Verbal forms for the expression of provisions).

"**must**" and "**must not**" are **NOT** allowed in ETSI deliverables except when used in direct citation.

Contents

Intellectual Property Rights	2
Foreword.....	2
Modal verbs terminology.....	2
Foreword.....	5
1 Scope	6
2 References	6
3 Definitions and abbreviations.....	7
3.1 Definitions	7
3.2 Abbreviations	9
4 Overview	10
4.1 General	10
4.2 3GPP specifications relevant for roaming architecture and procedures	10
4.3 Consideration of SIP header fields and elements	11
4.3.1 Inter Operator Identifier	11
4.3.1.1 Type of IOI's	11
4.3.1.2 Format of IOI's	11
4.3.1.3 Basic IMS roaming scenario without loopback.....	12
4.3.1.4 Originating visited network with loopback routeing scenario.....	13
4.3.1.5 Rules for transit-ioi	13
4.3.2 Naming of URIs.....	15
4.3.2.1 General	15
4.3.2.2 Home Network Domain	15
4.3.2.3 Private user identity.....	15
4.3.2.4 Public user identity.....	16
4.3.2.5 Instance-ID.....	16
4.4 Identifying the II-NNI traversal scenario	16
4.5 Use of preconditions in IMS networks	17
4.6 Loopback-indication header field parameter	17
5 Description of Scenarios	17
5.1 General	17
5.1.1 Methodology.....	17
5.1.1.1 Key required to interpret signalling flow in message coding examples	17
5.1.1.2 Functional entities covered in example flows	18
5.1.1.3 Notation conventions	19
5.1.1.3.1 Introduction	19
5.1.1.3.2 Public user Identities, public service identities and IP addresses	19
5.1.1.3.3 Network Entities	20
5.1.1.3.3.1 Served user UE-A's associated entities	20
5.1.1.3.3.2 Remote user's associated entities	20
5.1.1.3.3.3 Interconnection networks associated entities	20
5.1.1.4 IOI values.....	20
5.2 Registration when roaming.....	21
5.2.1 General.....	21
5.2.2 Registration via IC SIP proxies.....	21
5.2.3 Subscription to the registration-state event package	28
5.2.3.1 General	28
5.2.3.2 The UE subscribes to the registration-state event package	28
5.2.3.3 The P-CSCF subscribes to the registration-state event package	36
5.3 Originating roaming without loopback.....	43
5.3.1 General.....	43
5.3.2 Call flow	43
5.4 Originating roaming with loopback.....	52
5.4.1 General.....	52
5.4.2 Call flow	52

5.5	Routeing when the originating and terminating user reside in the same home network	71
5.6	Routeing from originating home to terminating home network	71
5.7	Routeing from originating visited network to terminating home network	71
5.8	Routeing in terminating home network when user resides in this network	72
5.9	Routeing from terminating home network to the terminating visited network.....	72
5.10	Insertion of service related media in the originating home network	80
5.10.1	General.....	80
5.10.2	Insertion of service related media in the originating home network with loopback	81
5.10.3	Insertion of service related media in the originating home network without loopback	84
5.11	PS to CS SRVCC access transfer scenarios	86
5.11.1	General.....	86
5.11.2	PS to CS SRVCC information transfer during registration.....	86
5.11.3	PS to CS SRVCC access transfer for a call in the active phase without loopback	94
5.11.4	PS to CS SRVCC access transfer for a call in the active phase with loopback	102
5.12	Invocation and configuration of services during roaming in a visited network.....	104
Annex A:	Change history	105
History		106

Foreword

This Technical Report has been produced by the 3rd Generation Partnership Project (3GPP).

The contents of the present document are subject to continuing work within the TSG and may change following formal TSG approval. Should the TSG modify the contents of the present document, it will be re-released by the TSG with an identifying change of release date and an increase in version number as follows:

Version x.y.z

where:

- x the first digit:
 - 1 presented to TSG for information;
 - 2 presented to TSG for approval;
 - 3 or greater indicates TSG approved document under change control.
- y the second digit is incremented for all changes of substance, i.e. technical enhancements, corrections, updates, etc.
- z the third digit is incremented when editorial only changes have been incorporated in the document.

1 Scope

The present document describes end-to-end use cases and signalling flows based on the roaming architecture for voice over IMS with local breakout. It summarizes the contents of existing 3GPP technical specifications which are needed for roaming use cases. The scenarios used cover the following use cases:

- registration when roaming;
- routing from originating visited network to originating home network;
- loopback routing from originating home network to originating visited network;
- routing when the originating and terminating user reside in the same home network;
- routing from the originating home network to the terminating home network;
- routing from the originating visited network to the terminating home network;
- routing in terminating home network when user resides in this network;
- routing from terminating home network to the terminating visited network;
- insertion of service related media in the originating home network;
- routing through transit networks; and
- access transfer scenarios (SRVCC).

Editor's note: It is ffs if the call forwarding service invocation in a Call Deflection case will be considered.

2 References

The following documents contain provisions which, through reference in this text, constitute provisions of the present document.

- References are either specific (identified by date of publication, edition number, version number, etc.) or non-specific.
- For a specific reference, subsequent revisions do not apply.
- For a non-specific reference, the latest version applies. In the case of a reference to a 3GPP document (including a GSM document), a non-specific reference implicitly refers to the latest version of that document *in the same Release as the present document*.

- [1] 3GPP TR 21.905: "Vocabulary for 3GPP Specifications".
- [2] 3GPP TS 23.002: "Network architecture".
- [3] 3GPP TS 23.228: "IP multimedia subsystem; Stage 2".
- [4] 3GPP TS 24.229: "IP multimedia call control protocol based on Session Initiation Protocol (SIP) and Session Description Protocol (SDP); Stage 3".
- [5] 3GPP TS 29.079: "Optimal Media Routeing within the IP Multimedia Subsystem; Stage 3".
- [6] 3GPP TS 29.165: "Inter-IMS Network to Network Interface (NNI)".
- [7] 3GPP TR 23.850: "Study on roaming architecture for voice over IP Multimedia Subsystem (IMS) with local breakout" (Release 11).
- [8] GSMA IR.92: "IMS Profile for Voice and SMS".
- [9] IETF RFC 3261: "SIP: Session Initiation Protocol".

- [10] IETF RFC 1594: "FYI on Questions and Answers to Commonly asked "New Internet User" Questions".
- [11] Void.
- [12] 3GPP TS 23.218: "IP Multimedia (IM) Session Handling; IM call model".
- [13] IETF RFC 3263: "Session Initiation Protocol (SIP): Locating SIP Servers".
- [14] 3GPP TS 29.228: "IP Multimedia (IM) Subsystem Cx and Dx Interfaces; Signalling flows and message contents".
- [15] GSMA IR.88: "LTE Roaming Guidelines".
- [16] 3GPP TS 23.003: "Numbering, addressing and identification".
- [17] IETF RFC 4282: "The Network Access Identifier".
- [18] IETF RFC 3966: "The tel URI for Telephone Numbers".
- [19] IETF RFC 4122: "A Universally Unique Identifier (UUID) URN Namespace".
- [20] 3GPP TS 24.237: "IP Multimedia Subsystem (IMS) Service Continuity; Stage 3".
- [21] IETF RFC 6809: "Mechanism to Indicate Support of Features and Capabilities in the Session Initiation Protocol (SIP)".
- [22] 3GPP TS 24.628: "Common Basic Communication procedures using IP Multimedia (IM)".
- [23] IETF RFC 3455: "Private Header (P-Header) Extensions to the Session Initiation Protocol (SIP) for the 3rd-Generation Partnership Project (3GPP)".
- [24] IETF RFC 2782: "A DNS RR for specifying the location of services (DNS SRV)".
- [25] 3GPP TS 32.260: "Telecommunication management; Charging management; IP Multimedia Subsystem (IMS) charging".
- [26] IETF RFC 7549: "3GPP SIP URI Inter Operator Traffic Leg parameter".
- [27] IETF RFC 3323: "A Privacy Mechanism for the Session Initiation Protocol (SIP)".
- [28] IETF RFC 3325: "Private Extensions to the Session Initiation Protocol (SIP) for Asserted Identity within Trusted Networks".
- [30] 3GPP TS 29.212: "Policy and Charging Control (PCC); Reference Points".
- [31] 3GPP TS 29.214: "Policy and charging control over Rx reference Point".
- [32] IETF RFC 3262 (June 2002): "Reliability of provisional responses in Session Initiation Protocol (SIP)".
- [33] IETF RFC 3312 (October 2002): "Integration of resource management and Session Initiation Protocol (SIP)".

3 Definitions and abbreviations

3.1 Definitions

For the purposes of the present document, the terms and definitions given in 3GPP TR 21.905 [1] and the following apply. A term defined in the present document takes precedence over the definition of the same term, if any, in 3GPP TR 21.905 [1].

For the purposes of the present document, the following terms and definitions given in 3GPP TS 24.229 [4] apply:

Entry point: In the case that "border control concepts", as specified in 3GPP TS 23.228 [3], are to be applied in an IM CN subsystem, then these are to be provided by capabilities within the IBCF, and the IBCF acts as an entry point for this network (instead of the I-CSCF). In this case the IBCF and the I-CSCF can be co-located as a single physical node. If "border control concepts" are not applied, then the I-CSCF is considered as an entry point of a network. If the P-CSCF is in the home network, then the I-CSCF is considered as an entry point for this document.

Exit point: If operator preference requires the application of "border control concepts" as specified in 3GPP TS 23.228 [3], then these are to be provided by capabilities within the IBCF, and requests sent towards another network are routed via a local network exit point (IBCF), which will then forward the request to the other network (discovering the entry point if necessary).

For the purposes of the present document, the following terms and definitions given in 3GPP TS 23.228 [3] subclauses 3.1, 4.3.3.1, 4.3.6, 4.6, 4.13, 5.2, 5.4.12.1 and 5.10 apply:

Border control concepts
Geo-local service number
Home local service number
Implicit registration set
Interconnection Border Control Function (IBCF)
Interrogating-CSCF (I-CSCF)
IMS Application Level Gateway (IMS-ALG)
IMS application reference
IMS Application Reference Identifier (IARI)
IMS communication service
IMS Communication Service Identifier (ICSI)
Local service number
IP-Connectivity Access Network (IP-CAN)
Policy and Charging Rule Function (PCRF)
Private user identity
Proxy-CSCF (P-CSCF)
Public Service Identity (PSI)
Public user identity
Serving-CSCF (S-CSCF)
Statically pre-configured PSI

For the purposes of the present document, the following terms and definitions given in IETF RFC 1594 [10] apply:

Fully-Qualified Domain Name (FQDN)

For the purposes of the present document, the following terms and definitions given in IETF RFC 3261 [9] apply:

Client
Dialog
Final response
Header
Header field
Loose routing
Method
Option-tag
Provisional response
Proxy, proxy server
Recursion
Redirect server
Registrar
Request
Response
Server
Session
(SIP) transaction
Stateful proxy
Stateless proxy
Status-code
Tag

Target Refresh Request
User agent client (UAC)
User agent server (UAS)
User agent (UA)

For the purposes of the present document, the following terms and definitions given in 3GPP TS 23.002 [2] clause 4.1.1.1 and clause 4a.7 apply:

Breakout Gateway Control Function (BGCF)
Call Session Control Function (CSCF)
Home Subscriber Server (HSS)
Location Retrieval Function (LRF)
Media Gateway Control Function (MGCF)
MSC Server enhanced for IMS centralized services
Multimedia Resource Function Controller (MRFC)
Multimedia Resource Function Processor (MRFP)
Subscription Locator Function (SLF)

For the purposes of the present document, the following terms and definitions given in 3GPP TS 23.218 [12] clause 3.1 apply:

Filter criteria
Initial filter criteria
Initial request
Standalone transaction
Subsequent request

3.2 Abbreviations

For the purposes of the present document, the abbreviations given in 3GPP TR 21.905 [1] and the following apply. An abbreviation defined in the present document takes precedence over the definition of the same abbreviation, if any, in 3GPP TR 21.905 [1].

AS	Application Server
ATCF	Access Transfer Control Function
ATGW	Access Transfer Gateway
ATU-STI	Access Transfer Update – Session Transfer Identifier
B2BUA	Back-to-Back User Agent
BGCF	Breakout Gateway Control Function
CdPty	Called Party
C-MSISDN	Correlation MSISDN
EATF	Emergency Access Transfer Function
E-CSCF	Emergency CSCF
ENUM	E.164 telephone Number Mapping
FQDN	Fully Qualified Domain Name
IARI	IMS Application Reference Identifier
IBCF	Interconnection Border Control Function
IC	Interconnection
ICID	IM CN subsystem Charging Identifier
I-CSCF	Interrogating CSCF
ICSI	IMS Communication Service Identifier
IMS	IP Multimedia core network Subsystem
IMSI	International Mobile Subscriber Identity
IOI	Inter Operator Identifier
LIA	Location Information Answer
LIR	Location Information Request
LRF	Location Retrieval Function
MCC	Mobile Country Code
MGCF	Media Gateway Control Function
MMTEL	Multimedia Telephony
MNC	Mobile Network Code

MOC	Mobile Originating Call
MPS	Multimedia Priority Service
MRFC	Multimedia Resource Function Controller
MRFP	Multimedia Resource Function Processor
OMR	Optimal Media Routing
PCRF	Policy and Charging Rules Function
P-CSCF	Proxy CSCF
PS	Packed Switched
PSAP	Public Safety Answering Point
PSI	Public Service Identity
SLA	Service Level Agreement
SLF	Subscription Locator Function
SCC AS	Service Centralization and Continuity AS
S-CSCF	Serving CSCF
SRVCC	Single Radio Voice Call Continuity
STN-SR	Session Transfer Number – Single Radio
TDM	Time Division Multiplex
TRF	Transit and Roaming Function
UA	User Agent
UAC	User Agent Client
UAS	User Agent Server
URN	Uniform Resource Name
VoLTE	Voice over LTE

4 Overview

4.1 General

This clause summarizes the contents of existing 3GPP technical specifications relevant for roaming architecture and procedures, describes how to format the Inter Operator Identifiers in the P-Charging-Vector header field, gives examples of used identities within the roaming use case and describes how to determine the II-NNI traversal scenario type.

4.2 3GPP specifications relevant for roaming architecture and procedures

This clause describes 3GPP specifications which are relevant for the implementation of VoLTE IMS roaming.

1. 3GPP TR 23.850 [7] investigated solutions for the provision of voice over IMS in roaming scenarios that facilitate the realization of a charging model that replicates the principles of CS model. The conclusions of this study were baseline for the roaming implementation in the 3GPP specifications. This document has now informational character.
2. 3GPP TS 23.002 [2] describes the common architecture and the related interfaces.
3. 3GPP TS 23.228 [3] describes the IP multimedia subsystem. The relevant sections which describes the roaming relevant stage 2 requirements are clause 4.2.3 (support of roaming users), clause 4.15a (roaming architecture for voice over IMS with local breakout), clause 5.6.1 ((MO#1) mobile origination, roaming), clause 5.7.1 ((MT#1) mobile termination, roaming) and clause 5.7.2a ((MT#3) mobile termination, CS domain roaming).
4. 3GPP TS 24.229 [4] especially describes the SIP and SDP signalling procedures for the IMS. The whole document distinguishes within the text if the procedures are relevant for roaming or non roaming cases or generally valid. Main sections which are mentioned to be specific to roaming additions are clause 5.7.1.16 (support of roaming architecture for voice over IMS with local breakout) and annex I (additional routing capabilities in support of transit, roaming and interconnection traffics in IM CN subsystem).
5. 3GPP TS 29.079 [5] describes the optimised media routing. Some roaming scenarios are described in clause 5.7 (roaming architecture for voice over IMS with local breakout) and in annex A different roaming scenarios with OMR are shown. Especially clause A.6 shows roaming case with loopback.

6. 3GPP TS 29.165 [6] describes the behaviour at the Inter-IMS Network to Network Interface (II-NNI) consisting of Ici and Izi reference points between IMS networks in order to support end-to-end service interoperability. This interface is essential for roaming.
7. GSMA IR.92 [8] describes the GSMA profile between UE and network based on 3GPP specifications.
8. 3GPP TS 22.153 [29] describes the service requirements for Multimedia Priority Service (MPS). MPS allows the ability to deliver calls or complete sessions of a high priority nature from mobile to mobile networks, mobile to fixed networks, and fixed to mobile networks. For roaming, appropriate priority information (e.g., marking with the Resource-Priority header field) across various interfaces is required in IMS CN and between IMS networks in order to support end-to-end MPS calls. The stage 3 in support of MPS is specified in (but not limited to): 3GPP TS 24.229 [4], 3GPP TS 29.165 [6], 3GPP TS 29.212 [30] and 3GPP TS 29.214 [31]. In particular, 3GPP TS 24.229 [4] describes the priority mechanisms and required priority information in SIP for MPS.

4.3 Consideration of SIP header fields and elements

4.3.1 Inter Operator Identifier

4.3.1.1 Type of IOI's

There are three types of IOI:

1. type 1 IOI, between the visited network and the home network:
 - between the P-CSCF and the S-CSCF;
 - between the S-CSCF and the TRF;
 - between the BGCF and the TRF;
 - between the MSC server and the I-CSCF; and
 - between the SCC AS and the ATCF;
2. type 2 IOI, between the originating network and the terminating network:
 - between the S-CSCF and the S-CSCF;
 - between the S-CSCF and the MGCF when a call/session is terminated at the PSTN/PLMN;
 - between the MGCF and the S-CSCF of the home terminating network when a call/session is originated from the PSTN/PLMN;

NOTE: This includes all scenarios with a PSI AS when accessed across I-CSCF.

 - between the TRF and the S-CSCF;
 - between the E-CSCF and the MGCF or the IBCF where the request is routed to a PSAP; and
 - between the E-CSCF and the S-CSCF or the IBCF when receiving an emergency request; and
3. type 3 IOI:
 - between the S-CSCF or the I-CSCF of the home operator network and any AS;
 - between the E-CSCF and the LRF;
 - between the E-CSCF and the EATF; and
 - between the transit function and the AS.

4.3.1.2 Format of IOI's

According to 3GPP TS 24.229 [4] clause 7.2A.5.2.1 the SIP entity generating type 1 and type 3 IOI values express the "orig-ioi" and "term-ioi" header field parameters in the format of a quoted string as specified in IETF RFC 3455 [23] with a specific string prefix being "Type 1" and "Type 3" respectively to indicate the type of IOI. For the type 2 IOI, no

string prefix is used. The receiving SIP entity does not perform syntactic checking of the contents of the IOI values (the IOI value is passed unmodified to the charging entities).

The following table shows some examples how to format IOI's.

Table 4.3.1.2-1: Examples for the format of IOI's

Example	Type of IOI	Prefix of IOI value	Example
P-CSCF – IBCF	Type 1	"Type 1"	"Type 1visited-A.net"
S-CSCF – IBCF (terminating path)	Type 2	none	"home-A.net"
S-CSCF - AS	Type 3	"Type 3"	"Type 3home-A.net"
originating home network to terminating home network	Type 2	none	"home-A.net"

4.3.1.3 Basic IMS roaming scenario without loopback

Within this basic approach 3 traversal scenarios exist which are shown in table 4.3.1.3-1.

Table 4.3.1.3-1: Traversal scenarios for basic IMS roaming scenario without loopback

Traversal scenario	Type of IOI
Originating visited network – originating home network	Type 1
Originating home network – terminating home network	Type 2
Terminating home network – terminating visited network	Type 1

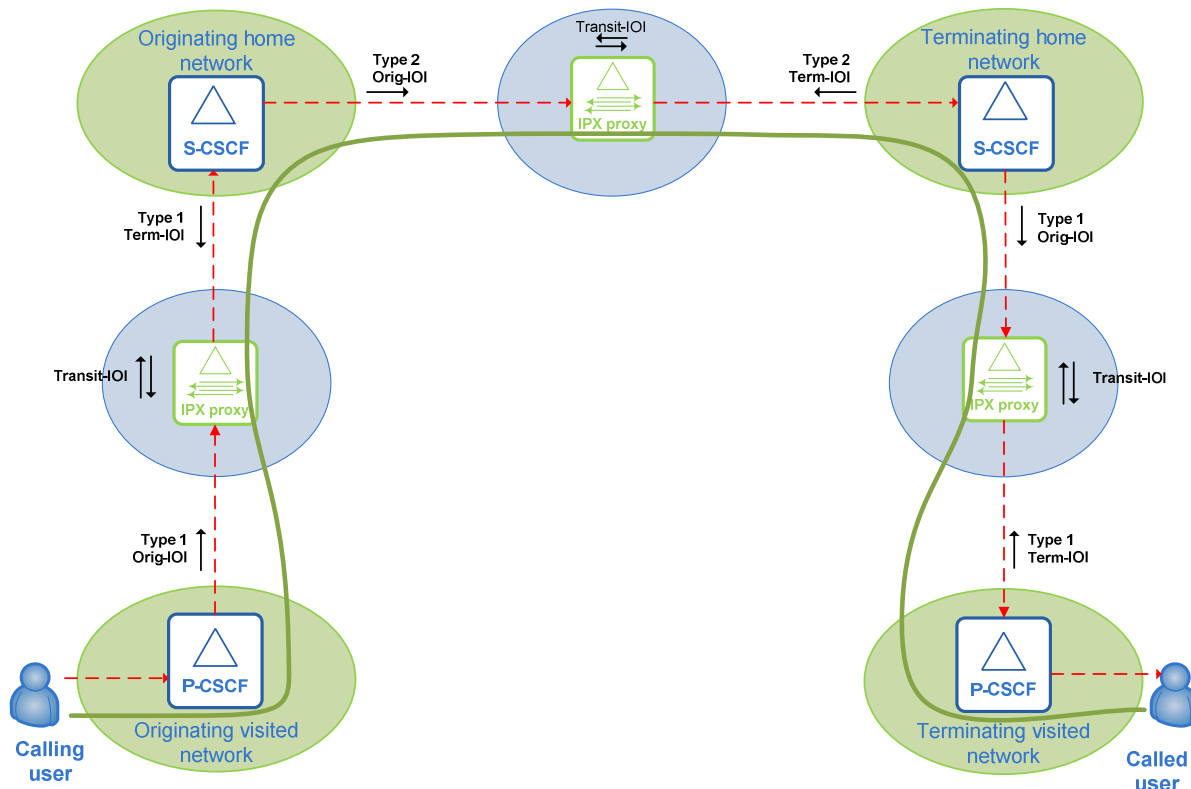

Figure 4.3.1.3-1: IOI information exchange for the "Basic IMS" roaming case with home routing of media

In order to meet the requirements of 3GPP TS 24.229 [4] there needs to be an IOI exchange including originating IOI, transit IOIs, and terminating IOI for each of the three signalling paths crossing network boundaries.

4.3.1.4 Originating visited network with loopback routing scenario

Within the loopback approach 4 traversal scenarios exist which are shown in table 4.3.1.4-1.

Table 4.3.1.4-1: Traversal scenarios for "Originating visited network with loopback routing scenario"

traversal scenario	Type of IOI
Originating visited network – originating home network	Type 1
Originating home network – originating visited network	Type 1
Originating visited network – terminating home network	Type 2
Terminating home network – terminating visited network	Type 1

For roaming with loopback the "Originating visited network with loopback routing scenario" introduces the case where the SIP signalling and the media are routed from the originating visited network to the destination and where the SIP signalling is first routed to the originating home network for a service execution and then back to the originating visited network to allow the originating visited network to route both SIP signalling and media to the destination.

The complete sequence of IOI exchanges for the IMS roaming scenario with originating visited network routing option is depicted in figure 4.3.1.4-1.

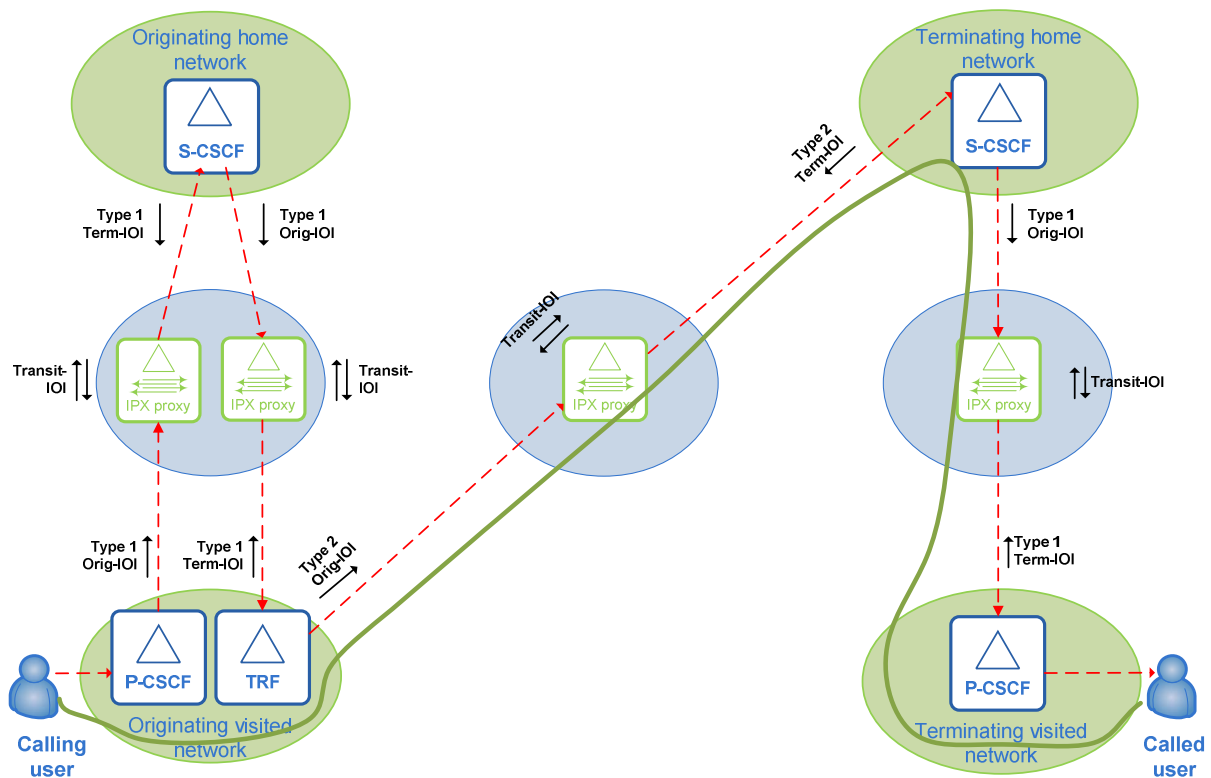

Figure 4.3.1.4-1: IOI exchange for IMS roaming with originating visited network with loopback routing

In order to meet the requirements of 3GPP TS 24.229 [4] there needs to be an IOI exchange including originating IOI, transit IOIs, and terminating IOI for each of four signalling paths crossing network boundaries.

4.3.1.5 Rules for transit-ioi

3GPP TS 24.229 [4] describes that for transit networks based on local policy the additional routing function in the transit network adds in requests and in responses the P-Charging-Vector header field a "transit-ioi" header field parameter with an entry which identifies the operator network which the request or response is transiting or with a void entry.

When the index is calculated then "void" entries are taken into account.

Based on local policy the additional routing function deletes or void in requests and in responses in the P-Charging-Vector header field any received "transit-ioi" header field parameter value.

Specific ruling may also apply to IBCF:

1. IBCF acting as entry point:

Based on local policy, the IBCF acting as an entry point adds in requests in the P-Charging-Vector header field a "transit-ioi" header field parameter with an entry which identifies the operator network which the request is transiting or with a void entry.

Based on local policy the IBCF deletes or void in requests in the P-Charging-Vector header field any received "transit-ioi" header field parameter value.

Only one "transit-ioi" header field parameter entry is added per transit network.

2. IBCF acting as exit point:

Based on local policy, the IBCF acting as an exit point adds in responses in the P-Charging-Vector header field a "transit-ioi" header field parameter with an entry which identifies the operator network which the response is transiting or with a void entry.

Based on local policy the IBCF deletes or void in responses in the P-Charging-Vector header field any received "transit-ioi" header field parameter value.

Considering figure 4.3.1.5-1 either the IBCF-entryA1 in combination with the IBCF-exitA1 or the transit function can do the setting of the transit-ioi. But also due to 3GPP TS 24.229 [4], subsection 4.5.4A, the transit function can control if a transit-ioi will be deleted or voided.

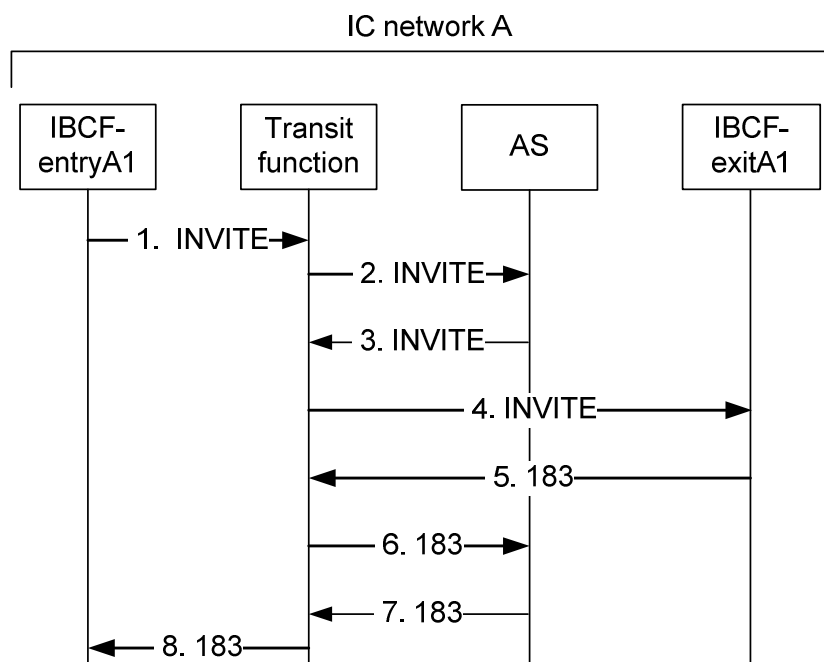

Figure 4.3.1.5-1: IOI exchange for IMS roaming transit

1. The IBCF-entryA1 receives an INVITE request containing the "transit-ioi" header field parameter in the P-Charging-Vector header field and sends the INVITE request towards the transit function.

NOTE 1: If no "transit-ioi" header field parameter is included or if the included "transit-ioi" header field parameter is missing a preceding interconnection network and the preceding network is an interconnection network, the IBCF-entryA1 can based on local policy, add the "transit-ioi" header field parameter with an entry identifying the preceding interconnection network.

2. The transit function stores and removes the "transit-ioi" header field parameter from the P-Charging-Vector header field, adds the Relayed-Charge header field with the content received in the "transit-ioi" and forwards the INVITE request to the AS.
3. The AS stores the content of the Relayed-Charge header field and sends the INVITE request to the transit function.
4. The transit function removes the Relayed-Charge header field and includes the stored "transit-ioi" header field parameter in the P-Charging-Vector header field. The transit function also appends an entry in the "transit-ioi". Based on local policy, the appended entry can identify the interconnection network or be set to void. The INVITE request is sent to the IBCF-exitA1.

NOTE 2: Based on local policy, the transit function can also void entries in the received "transit-ioi" header field parameter.

5. Upon receipt of a provisional response (in this case the 183 (Session Progress) response) containing the P-Charging-Vector header field, the IBCF-exitA1 sends the response to the transit function.

NOTE 3: If no "transit-ioi" header field parameter is included or if the included "transit-ioi" header field parameter is missing a preceding interconnection network and the preceding network is an interconnection network, the IBCF-exitA1 can based on local policy, add the "transit-ioi" header field parameter with an entry identifying the preceding interconnection network.

6. The transit function stores and removes the "transit-ioi" header field parameter from the P-Charging-Vector header field, adds the Relayed-Charge header field with the content received in the "transit-ioi" and forwards the 183 (Session Progress) response to the AS.
7. The AS stores the content of the Relayed-Charge header field and sends the 183 (Session Progress) response to the transit function.
8. The transit function removes the Relayed-Charge header field and includes the stored "transit-ioi" header field parameter in the P-Charging-Vector header field. The transit function also appends an entry in the "transit-ioi". Based on local policy, the appended entry can identify the interconnection network or be set to void. The 183 (Session Progress) response is sent to the IBCF-entryA1.

NOTE 4: Based on local policy, the transit function can also void entries in the received "transit-ioi" header field parameter.

4.3.2 Naming of URIs

4.3.2.1 General

3GPP TS 23.003 [16] defines the principal purpose and the use of International Mobile station Equipment Identities (IMEI) within the digital cellular telecommunications system and the 3GPP system.

Within the 3GPP TS 23.003 [16] clause 13 the numbering, addressing and identification within the IP multimedia core network subsystem are described.

This clause gives examples of used identities within the roaming use case. The normative statements in 3GPP TS 23.003 [16] apply.

4.3.2.2 Home Network Domain

The home network domain name is in the form of an internet domain name, e.g. operator.com.

3GPP TS 23.003 [16] clause 13.2 describes how to build the home network domain, if there is no ISIM application.

EXAMPLE: A home network domain name is: IMSI in use with 234150999999999 results in home network domain = ims.mnc015.mcc234.3gppnetwork.org.

4.3.2.3 Private user identity

3GPP TS 23.003 [16] clause 13.3 describes the principles how to build a private user identity.

The NAI as specified in IETF RFC 4282 [17] clause 2.1 for 3GPP systems with ISIM application the private user identity is derived from the IMSI.

EXAMPLE: If the IMSI is 234150999999999 (MCC = 234, MNC = 15), the private user identity then takes the form "234150999999999@ims.mnc015.mcc234.3gppnetwork.org".

4.3.2.4 Public user identity

3GPP TS 23.003 [16] clause 13.4 describes the principles how to build a public user identity.

The public user identity takes the form of either a SIP URI (see IETF RFC 3261 [9]) or a tel URI (see IETF RFC 3966 [18]).

According to 3GPP TS 29.165 [6] a global number as defined in IETF RFC 3966 [18] is used in a tel URI or in the user portion of a SIP URI with the "user=phone" parameter when conveyed via a non-roaming II-NNI except when agreement exists between the operators to also allow other kinds of numbers. For a roaming II-NNI no conventions are defined currently.

EXAMPLE 1: SIP URI: sip: +49892233445@operator.com; user=phone

EXAMPLE 2: SIP URI: sip: +49892233445@ 192.0.2.4; user=phone

EXAMPLE 3: SIP URI: sip: bob@operator.com

EXAMPLE 4: SIP: tel:+4687197378

4.3.2.5 Instance-ID

3GPP TS 23.003 [16] clause 13.8 describes the principles how to build an instance-id.

When an IMEI is available, the instance-id takes the form of an IMEI URN. An example of such an instance-id is as follows:

EXAMPLE 1: urn:gsma:imei:90420156-025763-0

If no IMEI is available, the instance-id takes the form of a string representation of a UUID as a URN as defined in IETF RFC 4122 [19]. An example of such an instance-id is as follows:

EXAMPLE 2: urn:uuid:f81d4fae-7dec-11d0-a765-00a0c91e6bf6

For more information on the instance-id and when it is used, see 3GPP TS 24.229 [4].

4.4 Identifying the II-NNI traversal scenario

Dialog creating SIP request and standalone request can optionally contain an "iotl" SIP URI parameter as specified in IETF RFC 7549 [26] and 3GPP TS 24.229 [4] in a Request-URI or in a Route header field. The "iotl" SIP URI parameter can be used to identify the II-NNI traversal scenario. The "iotl" SIP URI parameter is appended to the URI that represents the destination in CDRs.

One example on how the "iotl" SIP URI parameter is included in the Route header field by the P-CSCF in an originating visited network when sending a request towards the originating home network is shown below.

EXAMPLE: Route: < sip:ibcf-vA1.visited-A.net;lr>,< sip:home-abc@scscf-hA1.home-A.net;lr;iotl="visitedA-homeA">

If neither the Request-URI nor any of the Route header fields included in the SIP request contains the "iotl" SIP URI parameter, the II-NNI traversal scenario type can be determined by analysing the content of the SIP request or using a default II-NNI traversal scenario type. The recommended II-NNI traversal scenario type default value is "homeA-homeB".

NOTE: How the content of the SIP request can be used to determine the II-NNI traversal scenario is implementation dependent and outside the scope of this document.

The example use cases in this document assumes that the visited and home network supports the use of the "iotl" SIP URI parameter and the "iotl" SIP URI parameter are included in all coding examples.

4.5 Use of preconditions in IMS networks

An IMS UE can use preconditions based on local policy. The preconditions are defined within IETF RFC 3312 [33]. To process the preconditions IETF RFC 3262 [32] is needed. This IETF RFC 3262 [32] is describing the reliability of provisional responses which is needed to allow the reliable exchange of an SDP offer and SDP answer.

All use cases in this document are assuming preconditions. The similar call flows can appear without the preconditions mechanism.

Since 3GPP TS 24.229 [4] is stating that "100rel" option tag are used in circumstances of the use of preconditions the PRACK/200 OK is not sent in non precondition cases. Also the UPDATE/200 OK (UPDATE) is not sent since these messages are used to inform each other about the met resource reservation.

4.6 Loopback-indication header field parameter

When there is a desire to send the information that loopback has been applied to an entity, then the loopback-indication parameter in the P-Charging-Vector header field is used. This header field parameter can e.g. be evaluated when processing the P-CSCF CDR and possibly the ATCF CDR to know whether or not to attempt to locate a correlated TRF CDR even for the non-loopback scenario when no such CDR exists.

5 Description of Scenarios

5.1 General

5.1.1 Methodology

5.1.1.1 Key required to interpret signalling flow in message coding examples

Message coding examples are used to describe the contents of SIP messages.

The message coding examples include protocol elements that are of some interest for the interconnection use cases such as:

- a) protocol elements that contain address information (e.g. the Contact header field);
- b) protocol elements that contain routing information (e.g. the Route, Record-Route and Via header fields);
- c) protocol elements that can be used to identify the use case; and
- d) protocol elements that contain particular information of the use case.

Protocol elements that do not fulfil the above criteria are not included in the message coding examples, even if the protocol element is mandatory to be included in the SIP message. However, for completeness one or more references to 3GPP technical specifications are included at the end of the message coding examples.

The following key (rules) has been applied to each message coding examples to improve readability, reduce errors and increase maintainability:

- a) where a header field in the SIP message coding examples show only the header name including colon, the contents are identical to the received request/response. The received request/response is identified as follows:
 - where a request is generated as a result of a received request (as at a proxy), then the received request is that with the same method name and CSeq header;
 - where a response is generated as a result of a received response (as at a proxy), then the received response is that with the same method name and CSeq header;
 - where the response is generated as a result of a received request or response (as at an UA), then the received request is that with the same method name and CSeq header; and
 - where the request is generated as a result of a received response (as at an UA) then the received response is that immediately previously received;

To enhance readability an indication of the received request/response is included in the method title, should the received request/response not be the immediate preceding request/response.

- b) the (...) sequence of characters is used to indicate that the Content-Length field needs to be filled in, with the appropriate value i.e. the number of bytes in the payload;
- c) repeated headers within a message are listed on a single line, with a comma used as delimiter. This convention is not mandatory but used in this specification for improved readability;
- d) Header fields are listed within a table in the following order:
 - 1) end to end address information header fields (e.g. To and From);
 - 2) header fields that do not include end to end address information (e.g. the Route, Record-Route and P-Charging-Vector header fields); and
 - 3) Via header fields.

This convention is not mandatory but used in this specification for improved readability.

- e) UDP is always described in the Via header fields as a transport protocol even if the SIP message is actually longer than 1300 bytes. This convention is for improving readability and maintainability.

NOTE: According to 3GPP TS 24.229 [4] clause 4.2A, if the SIP message is longer than 1300 bytes, the IM CN subsystem entities transport the SIP message using a congestion controlled transport protocol, such as TCP.

5.1.1.2 Functional entities covered in example flows

The flows show the signalling exchanges between the following functional entities:

- User Equipment (UE);
- Proxy-CSCF (P-CSCF);
- Interrogating-CSCF (I-CSCF);
- Serving-CSCF (S-CSCF);
- Interconnection Border Control Function (IBCF);
- Application Server (AS);
- Service Centralization and Continuity Application Server (SCC AS);
- Mobile Switching Centre (MSC);
- Access Transfer Control Function (ATCF);
- Transit and Roaming Function (TRF);
- Media Gateway Control Function (MGCF);
- Breakout Gateway Control Function (BGCF);
- Home Subscriber Server (HSS); and
- SIP proxy or SIP application level gateway (ALG) in interconnection networks.

NOTE: The SIP proxy is assumed to have an additional routing functionality described in 3GPP TS 24.229 [4].

A number of the flows show a check against the filter criteria in the S-CSCF. A successful check against the filter criteria will involve the introduction of an application server into the path, operating in a number of different modes depending on the service provided. This could affect the example flows as follows:

- by the addition of extra URLs to a number of header fields, e.g. Via, Record-Route, within the flow in which the evaluation of filter criteria occurs;

- by the addition of extra URLs to a number of header fields, e.g. Via, Route in subsequent flows for the same dialog; and
- by the inclusion of functionality provided by the application server in this and subsequent flows.

5.1.1.3 Notation conventions

5.1.1.3.1 Introduction

This clause details the notation conventions used in the present document.

5.1.1.3.2 Public user Identities, public service identities and IP addresses

Table 5.1.1.3.2-1: The public user identities, public service identities and IP addresses used in message coding examples

	IP address	Public user identity / public service identities
UE-A	[5555::aaa:bbb:ccc:ddd]	sip:userA_public1@home-A.net tel:+1-237-555-1111 (NOTE 1)
Remote UE	[5555::bbb:ccc:ddd:aaa]	tel:+4687197378
P-CSCF-vA1	[5555::ddd:aaa:ccc:bbb]	sip:p-cscf@visited-A.net
S-CSCF-hA1	[5555::aaa:ccc:eee:aaa]	N/A
SCC AS	N/A	sip:ps2cs@sccas1.home-A.net (NOTE 2)
ATCF	N/A	tel:+12375553333 (NOTE 3)
IBCF-vA1	[5555::aaa:bbb:ccc:dd1]	N/A
IC-A1	[5555::aaa:bbb:ccc:dd2]	N/A
IBCF-hA1	[5555::aaa:bbb:ccc:dd3]	N/A
IC-T1	[5555::aaa:bbb:ccc:dd4]	N/A
NOTE 1: The tel URI is also used as the C-MSISDN.		
NOTE 2: The SIP URI is used as the ATU-STI during PS to CS SRVCC access transfer.		
NOTE 3: The tel URI is used as the STN-SR during PS to CS SRVCC access transfer.		

5.1.1.3.3 Network Entities

5.1.1.3.3.1 Served user UE-A's associated entities

Table 5.1.1.3.3.1-1: Domain name and FQDN used in message coding examples

Network	Domain name	Entity in the network	FQDN
UE-A's home network	home-A.net	S-CSCF serving UE-A	scscf-hA1.home-A.net
		I-CSCF(between proxy and S-CSCF)	icscf-hA1.home-A.net
		IBCF acting as an entry and exit point between the UE-A's visited network and the UE-A's home network	ibcf-hA1.home-A.net
		IBCF acting as an exit point between the UE-A's home network and the remote UE's home network	ibcf-hA2.home-A.net
		AS providing supplementary services	as-hA1.home-A.net
		AS providing the access transfer service	sccas-hA1.home-A.net
UE-A's visited network	visited-A.net	P-CSCF serving UE-A	pcscf-vA1.visited-A.net
		IBCF acting as an entry and exit point between the UE-A's visited network and the UE-A's home network and IBCF acting as an exit point between the UE-A's visited network and the remote UE's home network.	ibcf-vA1.visited-A.net
		ATCF	atcf-vA1.visited-A.net
		MSC server	msc-vA1.visited-A.net
		TRF	trf-vA1.visited-A.net

5.1.1.3.3.2 Remote user's associated entities

Table 5.1.1.3.3.2-1: Domain name and FQDN used in message coding examples

Network	Domain name	Entity in the network	FQDN
Remote UE's home network	home-R.net		

5.1.1.3.3.3 Interconnection networks associated entities

Table 5.1.1.3.3.3-1: Domain name and FQDN used in message coding examples

Network	Domain name	Entity in the network	FQDN
Interconnection network between the visited network A and the home network A	interconnection-A.net	SIP proxy	ic-A1.interconnection-A.net
Interconnection network between the visited network A and the remote home network or between the home network A and the remote home network R	interconnection-T.net	SIP proxy	ic-T1.interconnection-T.net

NOTE: Interconnection networks can also be SIP-unaware networks providing only IP routing. For the transit through such networks, no SIP proxies or SIP ALGs in interconnection networks are used. SIP entities in interconnection networks are shown with dotted lines in the flows to denote that they are optional.

5.1.1.4 IOI values

The IOI names used in the message coding examples are shown in table 5.1.1.4-1.

Table 5.1.1.4-1: The IOI values used in message coding examples

Network	IOI name (NOTE 1, NOTE 2, NOTE 3, NOTE 4)
Originating visited network	visited-a
Originating home network	home-a
Terminating visited network	visited-a
Terminating home network	home-a
Remote UE's home network	home-r
IC network A	ICa
IC network T	ICt
NOTE 1: The values for "orig-ioi" and "term-ioi" header field parameters are encoded in the format of a quoted string.	
NOTE 2: The value for an entry in "transit-ioi" header field parameter contains an indexed value.	
NOTE 3: The type 1 and type 3 IOIs are prefixed with specific strings (i.e. "Type1" and "Type3").	
NOTE 4: Since the same UE is used as the UE in originating and terminating coding examples the IOI name between the home and visited network will have the same value.	

5.2 Registration when roaming

5.2.1 General

This clause describes the registration process of a roaming user including the traversal of transit network between the visited and the originating home network.

5.2.2 Registration via IC SIP proxies

The registration procedure between the visited network and the home network uses an IC network which provides SIP proxy nodes to relay SIP traffic between these networks.

For the registration the UE addresses an FQDN in the home network domain which reflects the registrar (i.e. the S-CSCF of the home network). With this FQDN the IBCF acting as an exit point in the visited network chooses an IC provider and routes to a SIP proxy of the selected IC provider.

The SIP layer signalling is served by the IC provider's SIP proxy. The SIP proxy decides on the next SIP proxy towards the home network and routes to the next SIP proxy or to the IBCF acting as an entry point in the home network, if no further SIP proxy is required.

NOTE 1: The call flows just show scenarios with a single IC network and a single SIP proxy.

The user A at UE-A is roaming into a visited network vA. The user A is a subscriber of operator hA.

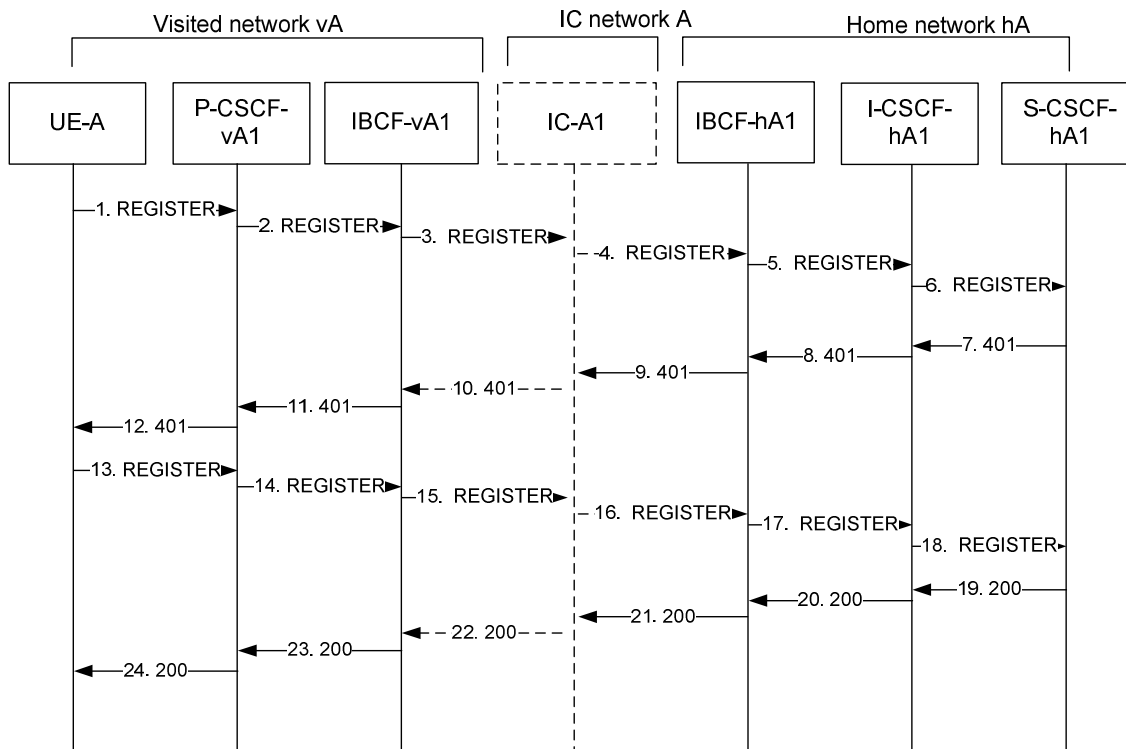

Figure 5.2.2-1: Message flow for Registration via IC SIP proxy

Call flow details:

1. REGISTER request (UE-A to P-CSCF-vA1) - see example in table 5.2.2-1.

The user A at UE-A initiates registration. The UE-A sends an initial REGISTER request to the P-CSCF-vA1 according to 3GPP TS 24.229 [4].

Table 5.2.2-1: REGISTER request (UE-A to P-CSCF-vA1)

```
REGISTER sip:home-A.net SIP/2.0

P-Access-Network-Info: 3GPP-E-UTRAN-TDD; utran-cell-id-3gpp=234151D0FCE11
From: <sip:userA_public1@home-A.net>;tag=4fa3
To: <sip:userA_public1@home-A.net>
Contact: <sip:[5555::aaa:bbb:ccc:ddd];reg-id=1; +sip.instance="<urn:gsma:imei:90420156-025763-0>" ;expires=600000
Via: SIP/2.0/UDP [5555::aaa:bbb:ccc:ddd];branch=z9hG4bKnashds7
CSeq: 1 REGISTER
Supported: path

Other SIP header fields are set according to 3GPP TS 24.229 [4].
```

- Request-URI:** The Request-URI sip:home-A.net (the URI that follows the method name, "REGISTER", in the first line) indicates the destination domain of this REGISTER request which is the home network.
- From:** Set to the SIP URI that is the default public user identity of the user A i.e. userA_public1@home-A.net.
- To:** Set to the SIP URI that is the default public user identity of the user A i.e. userA_public1@home-A.net.
- Supported:** The UE-A inserts the Supported header field containing the option-tag "path".

2. REGISTER request (P-CSCF-vA1 to IBCF-vA1) - see example in table 5.2.2-2.

When the P-CSCF-vA1 receives the initial REGISTER request the P-CSCF-vA1 adds the P-Visited-Network-ID header field containing the identifier of the P-CSCF network. This may be the visited network domain name or any other identifier that identifies the visited network at the home network.

The P-CSCF-vA1 needs to be in the path for all terminating requests for this user. To ensure this, the P-CSCF-vA1 adds itself to the Path header field for future requests.

The P-CSCF-vA1 selects an IBCF (IBCF-vA1) to be the IBCF acting as an exit point towards the home network hA of the user A and sends the REGISTER request according to 3GPP TS 24.229 [4] to IBCF-vA1.

Table 5.2.2-2: REGISTER request (P-CSCF-vA1 to IBCF-vA1)

```
REGISTER sip:home-A.net SIP/2.0

P-Access-Network-Info: 3GPP-E-UTRAN-TDD; utran-cell-id-3gpp=234151D0FCE11, 3GPP-E-UTRAN-TDD; utran-
cell-id-3gpp=234151D0FCE11;network-provided;local-time-zone="UTC+01:00";daylight-saving-time="01"
From:
To:
Contact:
CSeq:
Supported:
Require: path
Path: <sip:visit-xyz@pcscf-vA1.visited-A.net:5070;lr;iotl=homeB-visitedB>
Route: <sip:reg@ibcf-vA1.visited-A.net;lr>
P-Visited-Network-ID: "Visited Network Number A"
P-Charging-Vector: icid-value="AyretyU0dm+602IrT5tAFrbHLso=023551024";orig-ioi="Type 1visited-a"

Via: SIP/2.0/UDP pcscf-vA1.visited-A.net:5060;branch=z9hG4bKnas56565,
SIP/2.0/UDP [5555::aaa:bbb:ccc:ddd];branch=z9hG4bKnashds7
...

Other SIP header fields are set according to 3GPP TS 24.229 [4].
```

Route: P-CSCF-vA1 includes the selected IBCF-vA1 URI.

P-Charging-Vector: The P-CSCF-vA1 provides an ICID value and adds a type 1 "orig-ioi" header field parameter with the IOI value identifying the visited network (i.e. "visited-a").

Path: This is the address of the P-CSCF-vA1 and is included to inform the S-CSCF where to route terminating requests. The Path header field includes traffic leg information in the "iotl" SIP URI parameter according to IETF RFC 7549 [26].

Require: The P-CSCF-vA adds the Require header field containing the option-tag "path" to ensure that the recipient correctly handles the Path header field. If the recipient does not support the Path header field, a SIP response will be received with a status code of 420 and an Unsupported header field indicating the option-tag "path". Such a response indicates a wrong configuration of the routing tables and the request has been routed outside the IM CN subsystem.

Via: The P-CSCF-vA1 adds a Via header field with the address to receive the response to the REGISTER request.

P-Access-Network-Info: The P-CSCF-vA1 adds a network provided location, time-zone and daylight saving time. If it doesn't indicate that it is a network provided location, the P-Access-Network-Info header field containing the location provided by the UE-A is kept in the INVITE request.

3. REGISTER request (IBCF-vA1 to IC-A1) - see example in table 5.2.2-3.

The IBCF-vA1 receives the initial REGISTER request and analyses the request line and forwards registration to preferred VoIP IC provider (i.e. to IC A). The IBCF-vA1 determines the next hop IP address from the request URI either by configured information or using a DNS query according to IETF RFC 3263 [13]. If the subsequent interconnection network is SIP-aware, the determined IP address will belong to the SIP proxy IC-A1. Otherwise the determined IP address will point to IBCF-hA1 and step 4 is skipped (not reflected in message details below).

The IBCF-vA1 adds its own address to the Path header field.

Table 5.2.2-3: REGISTER request (IBCF-vA1 to IC-A1)

```
REGISTER sip:home-A.net SIP/2.0

P-Access-Network-Info:
From:
To:
Contact:
CSeq:
```



```
Supported:
Require:
Path: <sip:visit-abc@ibcf-vA1.visited-A.net:5070;lr>, <sip:visit-xyz@pcscf-vA1.visited-
A.net:5070;lr;iotl=homeB-visitedB>
Route: <sip:reg@ic-A1.interconnection-A.net;lr>
P-Visited-Network-ID:
P-Charging-Vector:
Via: SIP/2.0/UDP ibcf-vA1.visited-A.net;branch=z9hG4bK351g45.1,
SIP/2.0/UDP pcscf-vA1.visited-A.net:5060;branch=z9hG4bKnas56565,
SIP/2.0/UDP [5555::aaa:bbb:ccc:ddd];branch=z9hG4bKnashds7
...
Other SIP header fields are set according to 3GPP TS 24.229 [4].
```

Path: Based on topology hiding functionality the IBCF-vA1 will either forward the Path header field with:

- one visible IBCF-vA1 entry and the remaining collected entries as one hidden entry. If the SIP URI in the bottommost hidden Path header field contains an "iotl" SIP URI parameter then IBCF-vA1 will append an "iotl" SIP URI parameter with the same value to its own SIP URI in the Path header field; or
- one IBCF-vA1 entry and the whole content of already collected entries as visible entries.

Route: The IBCF-vA1 adds a Route header field identifying the selected node in the IC network A.

Via: Based on topology hiding functionality the IBCF-vA1 will either forward the Via header field with:

- one visible IBCF-vA1 entry and the remaining collected entries as one hidden entry; or
- one IBCF-vA1 entry and the whole content of already collected entries as visible entries.

4. REGISTER request (IC-A1 to IBCF-hA1) - see example in table 5.2.2-4.

NOTE 2: If the subsequent interconnection network is SIP-unaware, step 4 is skipped (not reflected in message details below).

The IC-A1 receives the initial REGISTER request and analyses the request line and forwards registration to the IBCF-hA1 of the home network of user A. The routing could either apply via DSN or any other routing mechanism.

Table 5.2.2-4: REGISTER request (IC-A1 to IBCF-hA1)

```
REGISTER sip:home-A.net SIP/2.0

P-Access-Network-Info:
From:
To:
CSeq:
Supported:
Require:
Contact:
Path: <sip:proxy-abc@ic-A1.interconnection-A.net:5070;lr>, <sip:visit-abc@ibcf-vA1.visited-
A.net:5070;lr>, <sip:visit-xyz@pcscf-vA1.visited-A.net:5070;lr;iotl=homeB-visitedB>
Route: <sip:reg@ibcf-hA1.home-A.net;lr>
P-Visited-Network-ID:
P-Charging-Vector: icid-value="AyretyU0dm+602IrT5tAFrbHLso=023551024";
orig-ioi="Type 1visited-a";transit-ioi="ICa.1"
Via: SIP/2.0/UDP ic-A1.interconnection-A.net;branch=z9hG4bK351g45.2,
SIP/2.0/UDP ibcf-vA1.visited-A.net;branch=z9hG4bK351g45.1,
SIP/2.0/UDP pcscf-vA1.visited-A.net:5060;branch=z9hG4bKnas56565,
SIP/2.0/UDP [5555::aaa:bbb:ccc:ddd];branch=z9hG4bKnashds7
...
Other SIP header fields are set according to 3GPP TS 24.229 [4].
```

P-Charging-Vector: In this example the IC-A1 adds the identity of the IC-A1 VoIP provider (i.e. "ICa") in the "transit-ioi" header field parameter. However, if the REGISTER request is routed via more than one IC VoIP provider network each IC VoIP provider receiving the REGISTER request adds a "transit-ioi" header field entry containing the IC VoIP provider identity.

- Path:** Based on SLA between IC partners and roaming partners the address of the IC-A1 will be added or not added by IC-A1.
- Route:** The IC-A1 adds a Route header field identifying the selected entry point in the home network hA.
- Via:** The Via header field is added by each proxy in IC networks, in this example the Via header field is only added by IC-A1.

5. REGISTER request (IBCF-hA1 to I-CSCF-hA1) - see example in table 5.2.2-5.

The IBCF-hA1 receives the initial REGISTER request and analyses the request line and forwards registration to the I-CSCF-hA1. The IBCF-hA1 adds a Route header field with the address of the I-CSCF-hA1 of the home network of user A. In this example, the IBCF-hA1 does not add any "transit-ioi" header field parameter in the P-Charging-Vector header field. However, the IBCF-hA1 adds the "transit-ioi" header field parameter based on local policy, when the "transit-ioi" identifying the preceding interconnection network is not included in the received request (e.g. when the preceding interconnection network is not an IMS transit network).

For performance reasons this I-CSCF-hA1 could be used only for registration traffic for roaming user which is due to local policy of the home network operator.

Table 5.2.2-5: REGISTER request (IBCF-hA1 to I-CSCF-hA1)

<pre>REGISTER sip:home-A.net SIP/2.0 P-Access-Network-Info: From: To: Contact: CSeq: Supported: Require: Path: <sip:home-abc@ibcf-hA1.home-A.net:5070;lr>, <sip:proxy-abc@ic-A1.interconnection- A.net:5070;lr>, <sip:visit-abc@ibcf-vA1.visited-A.net:5070;lr>, <sip:visit-xyz@pcscf-vA1.visited- A.net:5070;lr;iotl=homeB-visitedB> Route: <sip:reg@icscf-hA1.home-A.net;lr> P-Visited-Network-ID: P-Charging-Vector: Via: SIP/2.0/UDP ibcf-hA1.home-A.net;branch=z9hG4bK351g45.3, SIP/2.0/UDP ic-A1.interconnection-A.net;branch=z9hG4bK351g45.2, SIP/2.0/UDP ibcf-vA1.visited-A.net;branch=z9hG4bK351g45.1, SIP/2.0/UDP pcscf-vA1.visited-A.net:5060;branch=z9hG4bKnas56565, SIP/2.0/UDP [5555::aaa:bbb:ccc:ddd];branch=z9hG4bKnashds7 ... Other SIP header fields are set according to 3GPP TS 24.229 [4].</pre>
--

- Path:** The IBCF-hA1 adds a Path header field with the address to receive terminating dialog creating or stand-alone requests.
- Route:** The IBCF-hA1 adds a Route header field identifying the I-CSCF-hA1 of the home network of user A.
- Via:** The IBCF-hA1 adds a Via header field.

6. REGISTER request (I-CSCF-hA1 to S-CSCF-hA1) - see example in table 5.2.2-6.

The I-CSCF-hA1 receives the REGISTER request and makes a request for information related to the subscriber registration status by sending the private user identity, public user identity and visited domain name to the HSS. The HSS returns the S-CSCF required capabilities and the I-CSCF-hA1 uses this information to select a suitable S-CSCF.

Due to the fact that the I-CSCF-hA1 only identifies the home S-CSCF which is responsible for the roaming user A, the I-CSCF-hA1 is not needed for future requests to be kept in the path, thus an I-CSCF entry is not needed within the Path header field.

But for the response to the REGISTER message the I-CSCF-hA1 has to be added in the Via header field.

Table 5.2.2-6: REGISTER request (I-CSCF-hA1 to S-CSCF-hA1)

```
REGISTER sip:home-A.net SIP/2.0

P-Access-Network-Info:
From:
To:
Contact:
CSeq:
Supported:
Require:
Path:
Route: <sip:reg@scscf-hA1.home-A.net;lr>
P-Visited-Network-ID:
P-Charging-Vector:

Via: SIP/2.0/UDP icscf-hA1.home-A.net;branch=z9hG4bK351g45.4,
SIP/2.0/UDP ibcf-hA1.home-A.net;branch=z9hG4bK351g45.3,
SIP/2.0/UDP ic-A1.interconnection-A.net;branch=z9hG4bK351g45.2,
SIP/2.0/UDP ibcf-vA1.visited-A.net;branch=z9hG4bK351g45.1,
SIP/2.0/UDP pcscf-vA1.visited-A.net:5060;branch=z9hG4bKnas56565,
SIP/2.0/UDP [5555::aaa:bbb:ccc:ddd];branch=z9hG4bKnashds7
...

Other SIP header fields are set according to 3GPP TS 24.229 [4].
```

Route: The I-CSCF-hA1 adds the address of the selected S-CSCF.

Via: The I-CSCF-hA1 adds a Via header field with the address to receive the response to the REGISTER request.

7. 401 (Unauthorized) response (S-CSCF-hA1 to I-CSCF-hA1) - see example in table 5.2.2-7.

As the REGISTER request arrived without integrity protection to the P-CSCF, the S-CSCF-hA1 shall challenge the request. For this, the S-CSCF-hA1 requires at least one authentication vector to be used in the challenge to the user. If a valid authentication vector is not available, then the S-CSCF-hA1 requests at least one authentication vector from the HSS.

Table 5.2.2-7: 401 (Unauthorized) response (S-CSCF-hA1 to I-CSCF-hA1)

```
SIP/2.0 401 Unauthorized

Via: SIP/2.0/UDP icscf-hA1.home-A.net;branch=z9hG4bK351g45.4,
SIP/2.0/UDP ibcf-hA1.home-A.net;branch=z9hG4bK351g45.3,
SIP/2.0/UDP ic-A1.interconnection-A.net;branch=z9hG4bK351g45.2,
SIP/2.0/UDP ibcf-vA1.visited-A.net;branch=z9hG4bK351g45.1,
SIP/2.0/UDP pcscf-vA1.visited-A.net:5060;branch=z9hG4bKnas56565,
SIP/2.0/UDP [5555::aaa:bbb:ccc:ddd];branch=z9hG4bKnashds7

From:
To: <sip:userA_public1@home-A.net>;tag=5ef4
CSeq:
P-Charging-Vector: icid-value="AyretyU0dm+602IrT5tAFrbHLso=023551024";orig-ioi="Type lvisited-a";term-ioi="Type lhome-a"
WWW-Authenticate: Digest realm="registrar.home-A.net", nonce="A34Cm+Fva37UYWpGNB34JP",
algorithm=AKAv1-MD5, ik="00112233445566778899aabbccddeeff", ck="ffeeddccbbaa11223344556677889900"

Other SIP header fields are set according to 3GPP TS 24.229 [4].
```

P-Charging-Vector: The P-Charging-Vector header field containing the "orig-ioi" header field parameter, if received in the REGISTER request and a type 1 "term-ioi" header field parameter. The S-CSCF-hA1 shall set the type 1 "term-ioi" header field parameter to a value that identifies the sending network of the response and the "orig-ioi" header field parameter is set to the previously received value of "orig-ioi" header field parameter. The "icid-value" header field parameter is set to the previously received value of "icid-value" header field parameter in the request.

WWW-Authenticate: The S-CSCF-hA1 includes the WWW-Authenticate header field with:

- the "realm" header field parameter containing a globally unique name of the S-CSCF-hA1;
- the "nonce" header field parameter containing the quoted string, base64 encoded value of the concatenation of the RANDom challenge (RAND) and Authentication Token (AUTN) parameters and optional server specific data for the UE;
- the security mechanism in the "algorithm" header field parameter;
- the Integrity Key parameter for the P-CSCF in the "ik" header field parameter; and
- the Cipher Key parameter for the P-CSCF in the "ck" header field parameter.

NOTE 3: If the interconnection network is SIP-unaware, step 10 is skipped.

8-12. 401 (Unauthorized) response (I-CSCF-hA1 to UE-A).

Normal response routing procedure as described within 3GPP TS 24.229 [4] applies. No specific roaming procedures apply.

NOTE 4: If the interconnection network is SIP-unaware, step 10 is skipped.

13-17. REGISTER request (UE-A to I-CSCF-hA1).

The authentication challenge response is calculated by the UE-A and then put into the Authorization header field and sent back to the registrar in the REGISTER request. Procedures are described within 3GPP TS 24.229 [4].

UE-A registers a second time with an authentication response.

With the exception of the Authorization header field, the CSeq header field value and the ICID value in the P-Charging-Vector header field, the REGISTER message will contain the same information and the Path header fields and the Via header fields will be set as described within steps 1-5 of this call flow.

NOTE 5: If the interconnection network is SIP-unaware, step 16 is skipped.

18. REGISTER request (I-CSCF-hA1 to S-CSCF-hA1).

I-CSCF-hA1 queries IMS-HSS (LIR/LIA) as described within 3GPP TS 29.228 [14] and routes to the previously assigned S-CSCF-hA1. It is the same procedure as described within step 6 of this call flow.

The Path header field will be set as described within step 6 of this call flow.

19-22. 200 OK response (S-CSCF-hA1 to IBCF-vA1) - see example in table 5.2.2-19.

S-CSCF-hA1 confirms the registration as described within 3GPP TS 24.229 [4]. There are no roaming specific procedures that apply in addition.

The table 5.2.2-19 shows the content of the 200 (OK) response when sent by S-CSCF-hA1.

Table 5.2.2-19: 200 OK response (S-CSCF-hA1 to IBCF-vA1)

<pre> SIP/2.0 200 OK Via: SIP/2.0/UDP icscf-hA1.home-A.net;branch=z9hG4bK351g45.4, SIP/2.0/UDP ibcf-hA1.home-A.net;branch=z9hG4bK351g45.3, SIP/2.0/UDP ic-A1.interconnection-A.net;branch=z9hG4bK351g45.2, SIP/2.0/UDP ibcf-vA1.visited-A.net;branch=z9hG4bK351g45.1, SIP/2.0/UDP pcscf-vA1.visited-A.net:5060;branch=z9hG4bKnas56565, SIP/2.0/UDP [5555::aaa:bbb:ccc:ddd];branch=z9hG4bKnashds7 From: Service-Route: <sip:home-abc@scscf-hA1.home-A.net;lr;iotl=visitedA-homeA> To: CSeq: 2 REGISTER Contact: P-Associated-URI: <sip:userA_publicl@home-A.net>, <tel:+1-237-555-1111> P-Charging-Vector: icid-value="AyretyU0dm+602IrT5tAFrbHLso=023551024";orig-ioi="Type lvisited-a";term-ioi="Type lhome-a" Path: <sip:home-abc@ibcf-hA1.home-A.net:5070;lr>, <sip:proxy-abc@ic-A1.interconnection-A.net:5070;lr>, <sip:visit-abc@ibcf-vA1.visited-A.net:5070;lr>, <sip:visit-xyz@pcscf-vA1.visited-A.net:5070;lr;iotl=homeB-visitedB> Other SIP header fields are set according to 3GPP TS 24.229 [4]. </pre>

- Path:** List of Path header field received in the REGISTER request will be included. (IBCF-hA1, IC-A1, IBCF-vA1, P-CSCF-vA1).
- P-Associated-URI:** Containing the list of the registered distinct public user identity and its associated set of implicitly registered distinct public user identities. The first URI in the list of public user identities supplied by the HSS to the S-CSCF will indicate the default public user identity to be used by the S-CSCF.
- Service-Route:** Contains the SIP URI identifying the S-CSCF (S-CSCF-hA1) containing an indication that subsequent requests routed via this service route (i.e. from the P-CSCF to the S-CSCF). In case network topology hiding is required by the home network, a visible SIP URI identifying the IBCF (IBCF-hA1) will be added by the IBCF acting as an entry point as the topmost entry and a hidden SIP URI identifying the S-CSCF (S-CSCF-hA1) in the bottom. The Service-Route header field includes traffic leg information in the "iotl" SIP URI parameter according to IETF RFC 7549 [26].
- P-Charging-Vector:** The P-Charging-Vector header field containing the "orig-ioi" header field parameter, if received in the REGISTER request and a type 1 "term-ioi" header field parameter. The S-CSCF-hA1 shall set the type 1 "term-ioi" header field parameter to a value that identifies the sending network of the response and the "orig-ioi" header field parameter is set to the previously received value of "orig-ioi" header field parameter. The "icid-value" header field parameter is set to the previously received value of "icid-value" header field parameter in the request.

23. 200 OK response (IBCF-vA1 to P-CSCF-vA1).

If topology hiding is required by the visited network and the IBCF-vA1 applied topology hiding on the Path and Via header fields contained in the REGISTER request, the IBCF-vA1 performs a decryption procedure on the received Path and Via header fields, as described in clause 5.10.4.3 of 3GPP TS 24.229 [4], and inserts a "+g.3gpp.thig-path" Feature-Caps header field parameter set to the same IBCF-vA1's SIP URI value as included in the Path header field of the REGISTER request sent to the home network.

24. 200 OK response (P-CSCF-vA1 to UE-A).

The P-CSCF-vA1 stores the value of received "+g.3gpp.thig-path" Feature-Caps header field parameter and removes the "+g.3gpp.thig-path" Feature-Caps header field parameter before forwarding the 200 (OK) response to the UE-A.

5.2.3 Subscription to the registration-state event package

5.2.3.1 General

After that the registration in clause 5.2.2 is successfully completed the UE and the P-CSCF subscribes to the registration-state event package as described in 3GPP TS 24.229 [4].

The difference between the UE-A subscription and the P-CSCF-vA1 subscription is that the UE-A sends the SUBSCRIBE request using the registration path while the P-CSCF-vA1 is using the NNI i.e. for the IC network A it will appear as the SUBSCRIBE request sent by the P-CSCF-vA1 is between two home networks.

NOTE: The message flows in clause 5.2.3.2 and clause 5.2.3.3 are independent and can be done in parallel.

5.2.3.2 The UE subscribes to the registration-state event package

After that the registration in clause 5.2.2 is successfully completed the UE subscribes to the registration-state event package as described in 3GPP TS 24.229 [4] clause 5.1.1.3.

Figure 5.2.3.2-1 shows how the UE-A sends the SUBSCRIBE request using the registration path.

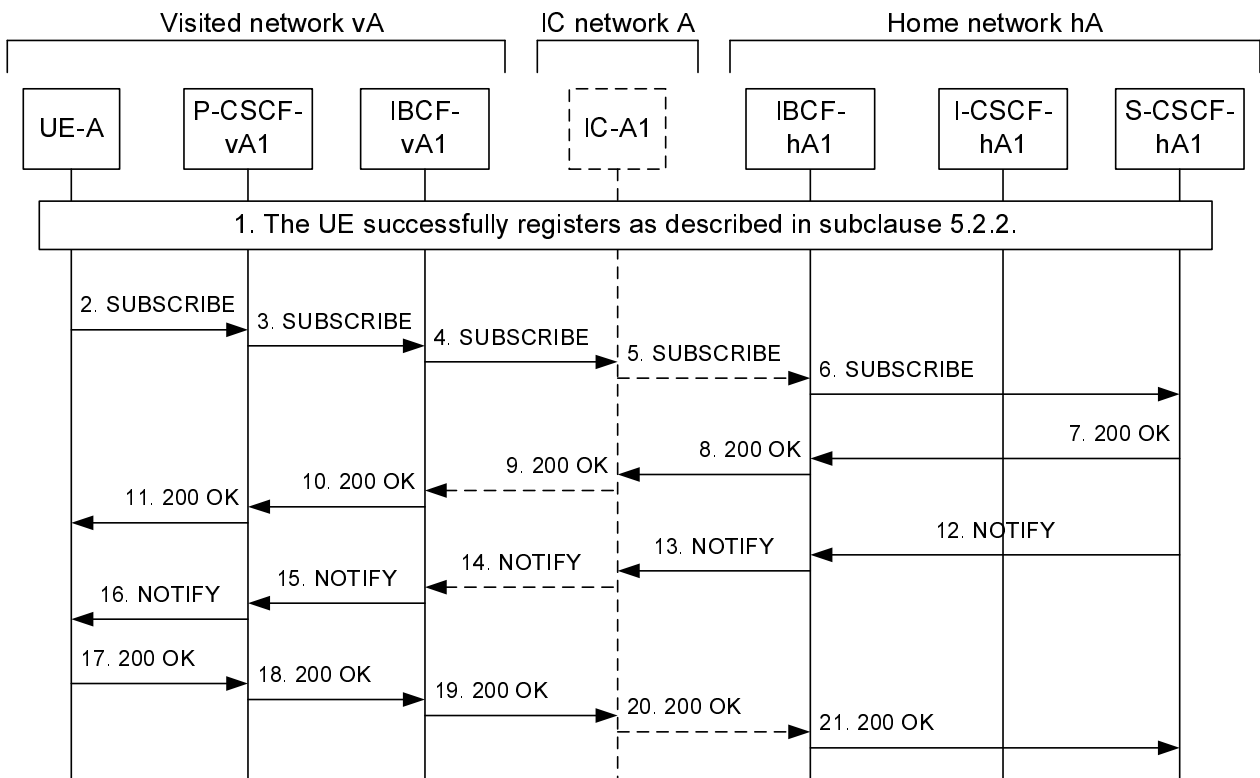

Figure 5.2.3.2-1: Subscription to the registration-state event package by the UE-A

The steps of the flow are as follows:

1. The UE successfully registers as described in clause 5.2.2.
2. **SUBSCRIBE request (UE-A to P-CSCF-vA1) - see example in table 5.2.3.2-2.**

The UE-A sends the SUBSCRIBE request as specified in 3GPP TS 24.229 [4] using the registration path created by the registration in clause 5.2.2.

Table 5.2.3.2-2: SUBSCRIBE request (UE-A to P-CSCF-vA1)

```
SUBSCRIBE sip:userA_public1@home-A.net SIP/2.0

From: <sip:userA_public1@home-A.net>;tag=4fa3
To: <sip:userA_public1@home-A.net>
Route: <sip:pcscf-vA1.visited-A.net;lr>,<sip:home-abc@scscf-hA1.home-A.net;lr;iotl=visitedA-homeA>
P-Preferred-Identity: <sip:userA_public1@home-A.net>
Contact: <sip:[5555::aaa:bbb:ccc:ddd]>
CSeq: 1 SUBSCRIBE
Event: reg
Expires: 600000
Accept: application/reginfo+xml
P-Access-Network-Info: 3GPP-E-UTRAN-TDD; utran-cell-id-3gpp=234151D0FCE11

Via: SIP/2.0/UDP [5555::aaa:bbb:ccc:ddd];branch=z9hG4bKnashds7

Other SIP header fields are set according to 3GPP TS 24.229 [4].
```

- Request-URI:** Set to the SIP URI that is the default public user identity of the user A i.e. userA_public1@home-A.net.
- From:** Set to the SIP URI that is the default public user identity of the user A i.e. userA_public1@home-A.net.
- To:** Set to the SIP URI that is the default public user identity of the user A i.e. userA_public1@home-A.net.

Route: The UE-A builds a proper preloaded route set for the SUBSCRIBE dialog containing the IP address or the FQDN learnt through the P-CSCF discovery procedures and P-CSCF port based on the security mechanism in use. In addition the values received in the Service-Route header field saved from the 200 (OK) response to the last registration or re-registration of the public user identity with associated contact address are added. The content of the received Service-Route header field is due to operator policy. In this example only the S-CSCF-hA1 (including traffic leg information in the "iotl" SIP URI parameter according to IETF RFC 7549 [26]) will be included.

P-Preferred-Identity: Set to the SIP URI that is the default public user identity of the user A i.e. userA_public1@home-A.net.

Event: The value of the Event header field is set to the value "reg" to specify the use of the registration state package.

Accept: The value of the Accept header field is set to "application/reginfo+xml".

3. SUBSCRIBE request (P-CSCF-vA1 to IBCF-vA1) – see example in table 5.2.3.2-3.

When the P-CSCF-vA1 receives the SUBSCRIBE request and the P-CSCF-vA1 verifies that the resulting list of Route header fields matches the list of URIs received in the Service-Route header field (during the last successful registration or re-registration). This verification is done on a per URI basis, not as a whole string.

The P-CSCF-vA1 selects an IBCF (IBCF-vA1) to be the exit IBCF towards the home network hA and sends the SUBSCRIBE request according to 3GPP TS 24.229 [4] to IBCF-vA1.

Table 5.2.3.2-3: SUBSCRIBE request (P-CSCF-vA1 to IBCF-vA1)

```

SUBSCRIBE sip:userA_public1@home-A.net SIP/2.0

From:
To:
P-Asserted-Identity: <sip:userA_public1@home-A.net>
Route: <sip:ibcf-vA1.visited-A.net;lr>,<sip:home-abc@scscf-hA1.home-A.net;lr;iotl=visitedA-homeA>
Record-Route: <sip:pcscf-vA1.visited-A.net;lr>
Contact:
CSeq:
Event:
Expires:
Accept:
P-Access-Network-Info: 3GPP-E-UTRAN-TDD;utran-cell-id-3gpp=234151D0FCE11,
    3GPP-E-UTRAN-TDD; utran-cell-id-3gpp=234151D0FCE11;
    network-provided;local-time-zone="UTC+01:00";daylight-saving-time="01"
P-Charging-Vector: icid-value="AyretyU0dm+6O2IrT5tAFrbHLso=023551024";orig-ioi="Type 1visited-a"

Via: SIP/2.0/UDP pcscf-vA1.visited-A.net:5060;branch=z9hG4bKnas56565
Via: SIP/2.0/UDP [5555::aaa:bbb:ccc:ddd];branch=z9hG4bKnashds7

Other SIP header fields are set according to 3GPP TS 24.229 [4].

```

P-Asserted-Identity: The value is set to the default public user identity i.e. userA_public1@home-A.net.

P-Charging-Vector: The P-CSCF-vA1 adds the P-Charging-Vector header field containing a new ICID value in the "icid" header field parameter and an "orig-ioi" header field parameter. The IOI value is of type 1 and identifies the visited network vA (i.e. visited-a).

P-Access-Network-Info: The P-CSCF adds a network provided location and daylight saving information. If the received P-Access-Network-Info header field doesn't indicate that it is a network provided location, the P-Access-Network-Info header field containing the location provided by the UE-A is kept in the INVITE request.

Route: The P-CSCF adds a Route header field identifying the selected IBCF-vA1.

Record-Route: The P-CSCF adds a Record-Route header field.

Via: The P-CSCF adds a Via header field.

4. SUBSCRIBE request (IBCF-vA1 to IC-A1) – see example in table 5.2.3.2-4.

When the IBCF-vA1 receives the SUBSCRIBE request the IBCF-vA1 selects, based on local policy, to route the SUBSCRIBE request via IC network A and sends the SUBSCRIBE request according to 3GPP TS 24.229 [4] to the IC-A1. The IBCF-vA1 determines the next hop IP address from the URI in the first Route header field entry either by configured information or using a DNS query according to IETF RFC 3263 [13]. If the subsequent interconnection network is SIP-aware, the determined IP address will belong to the SIP proxy IC-A1. Otherwise the determined IP address will point to IBCF-hA1 and step 5 is skipped (not reflected in message details below).

Table 5.2.3.2-4: SUBSCRIBE request (IBCF-vA1 to IC-A1)

<pre> SUBSCRIBE sip:userA_public1@home-A.net SIP/2.0 From: To: P-Asserted-Identity: Route: <sip:ic-A1.interconnection-A.net;lr>, <sip:home-abc@scscf-hA1.home-A.net;lr;iotl=visitedA-homeA> Record-Route:<sip:ibcf-vA1.visited-A.net;lr>, <sip:pcscf-vA1.visited-A.net;lr> Contact: CSeq: Event: Expires: Accept: P-Access-Network-Info: P-Charging-Vector: Via: SIP/2.0/UDP ibcf-vA1.visited-A.net;branch=z9hG4bK351g45.1 Via: SIP/2.0/UDP pcscf-vA1.visited-A.net:5060;branch=z9hG4bKnas56565 Via: SIP/2.0/UDP [5555::aaa:bbb:ccc:ddd];branch=z9hG4bKnashds7 Other SIP header fields are set according to 3GPP TS 24.229 [4]. </pre>

Route: The IBCF-vA1 adds a Route header field identifying the selected node in the IC network A.

Record-Route: Based on topology hiding functionality the IBCF-vA1 will either forward the Record-Route header field with:

- one visible IBCF-vA1 entry and the remaining collected entries as one hidden entry; or
- an IBCF-vA1 entry and whole content of already collected entries as visible entries.

Via: Based on topology hiding functionality the IBCF-vA1 will either forward the Via header field with:

- one visible IBCF-vA1 entry and the remaining collected entries as one hidden entry; or
- an IBCF-vA1 entry and whole content of already collected entries as visible entries.

5. SUBSCRIBE request (IC-A1 to IBCF-hA1) – see example in table 5.2.3.2-5.

NOTE 1: If the interconnection network is SIP-unaware, step 5 is skipped (not reflected in message details below).

When the IC-A1 receives the SUBSCRIBE request the IC-A1 selects an entry point (IBCF-hA1) of the home network hA and sends the SUBSCRIBE request according to 3GPP TS 24.229 [4] to the IBCF-hA1.

The IC-A1 can add a Route header field pointing to the entry point of the home network hA. This is shown in the example in table 5.2.3-5.

Table 5.2.3.2-5: SUBSCRIBE request (IC-A1 to IBCF-hA1)

```

SUBSCRIBE sip:userA_public1@home-A.net SIP/2.0

From:
To:
P-Asserted-Identity:
Route: <sip:ibcf-hA1.home-A.net;lr>,<sip:home-abc@scscf-hA1.home-A.net;lr;iotl=visitedA-homeA>
Record-Route: <sip:ic-A1.interconnection-A.net;lr>,<sip:ibcf-vA1.visited-A.net;lr>,<sip:pcscf-
vA1.visited-A.net;lr>
Contact:
CSeq:
Event:
Expires:
Accept:
P-Access-Network-Info:
P-Charging-Vector: icid-value="AyretyU0dm+6O2IrT5tAFrbHLso=023551024";orig-ioi="Type 1visited-
a";transit-ioi="ICa.1"

Via: SIP/2.0/UDP ic-A1.interconnection-A.net;branch=z9hG4bK351g45.2
Via: SIP/2.0/UDP ibcf-vA1.visited-A.net;branch=z9hG4bK351g45.1
Via: SIP/2.0/UDP pcscf-vA1.visited-A.net:5060;branch=z9hG4bKnas56565
Via: SIP/2.0/UDP [5555::aaa:bbb:ccc:ddd];branch=z9hG4bKnashds7

Other SIP header fields are set according to 3GPP TS 24.229 [4].

```

P-Charging-Vector: The IC-A1 adds the "transit-ioi" header field parameter identifying the interconnection network (i.e. ICa.1).

Route: The IC-A1 adds a Route header field identifying the selected entry point in the home network hA.

Record-Route: Based on interconnection operator SLA the IC-A1 adds an entry to the Record-Route header field or not.

Via: The IC-A1 adds a Via header field.

6. SUBSCRIBE request (IBCF-hA1 to S-CSCF-hA1) – see example in table 5.2.3.2-6.

When the IBCF-hA1 receives the SUBSCRIBE request the IBCF-hA1 sends the SUBSCRIBE request according to 3GPP TS 24.229 [4] to the S-CSCF-hA1.

In this example, the IBCF-hA1 does not add any "transit-ioi" header field parameter in the P-Charging-Vector header field. However, the IBCF-hA1 adds the "transit-ioi" header field parameter based on local policy, when the "transit-ioi" identifying the preceding interconnection network is not included in the received request (e.g. when the preceding interconnection network is not an IMS transit network).

Table 5.2.3.2-6: SUBSCRIBE request (IBCF-hA1 to S-CSCF-hA1)

```

SUBSCRIBE sip:userA_public1@home-A.net SIP/2.0

From:
To:
P-Asserted-Identity:
Route: <sip:home-abc@scscf-hA1.home-A.net;lr;iotl=visitedA-homeA>
Record-Route: <sip:ibcf-hA1.home-A.net:5070;lr>,<sip:ic-A1.interconnection-A.net;lr>,<sip:ibcf-
vA1.visited-A.net;lr>,<sip:pcscf-vA1.visited-A.net;lr>
Contact:
CSeq:
Event:
Expires:
Accept:
P-Access-Network-Info:
P-Charging-Vector:

Via: SIP/2.0/UDP ibcf-hA1.home-A.net;branch=z9hG4bK351g45.3
Via: SIP/2.0/UDP ic-A1.interconnection-A.net;branch=z9hG4bK351g45.2
Via: SIP/2.0/UDP ibcf-vA1.visited-A.net;branch=z9hG4bK351g45.1
Via: SIP/2.0/UDP pcscf-vA1.visited-A.net:5060;branch=z9hG4bKnas56565
Via: SIP/2.0/UDP [5555::aaa:bbb:ccc:ddd];branch=z9hG4bKnashds7

Other SIP header fields are set according to 3GPP TS 24.229 [4].

```

Via: The IBCF-hA1 adds a Via header field.

Record-Route: The IBCF-hA1 adds a Record-Route header field.

7-11. 200 (OK) response (S-CSCF-hA1 to UE-A).

The S-CSCF-hA1 acknowledges a successful subscription to the registration-state event package where:

- the S-CSCF-hA1 includes a P-Charging-Vector header field containing the same ICID value and "orig-ioi" header field parameter as received in the SUBSCRIBE request. In addition the S-CSCF-hA1 adds the "term-ioi" header field parameter with the IOI value set to a value identifying the home network A (i.e. home-a).
- the IC-A1 adds to the P-Charging-Vector header field the "transit-ioi" set to a value identifying the interconnection network (i.e. ICa.1).

NOTE 2: If the interconnection network is SIP-unaware, step 9 is skipped.

12. NOTIFY request (S-CSCF-hA1 to IBCF-hA1) – see example in table 5.2.3.2-12.

The S-CSCF-hA1 immediately after sending the 200 (OK) to the SUBSCRIBE request sends a NOTIFY request containing the registration-state event package in an application/reginfo+xml MIME body.

The NOTIFY request is sent along the path created by the routes received in the Record-Route header field.

Table 5.2.3.2-12: NOTIFY request (S-CSCF-hA1 to IBCF-hA1)

<pre>NOTIFY sip:[5555::aaa:bbb:ccc:ddd] SIP/2.0 To:<sip:userA_public1@home-A.net> From:<sip:userA_public1@home-A.net>;tag=3fa5 Route:<sip:ibcf-hA1.home-A.net;lr>,<sip:ic-A1.interconnection-A.net;lr>,<sip:ibcf-vA1.visited-A.net;lr>,<sip:pcscf-vA1.visited-A.net;lr> Call-ID:cb03a0s09a2sdfglkj490333 CSeq:25 NOTIFY Contact:sip:[5555::aaa:ccc:eee:aaa] Event:reg Subscription-State:active;expires=600000 P-Charging-Vector:icid-value="AyretyU0dm+602IrT5tAFrbHLso=45678901";orig-ioi="Type 1home-a" Via: SIP/2.0/UDP scscf-hA1.home-A.net;branch=z9hG4bK23456.1 Content-Type:application/reginfo+xml Content-Length:(...) For an example of the content of the SDP application/reginfo+xml see 3GPP TS 24.229 [4] subclause 5.4.2.1.2. Other SIP header fields are set according to 3GPP TS 24.229 [4].</pre>
--

Request-URI: The S-CSCF-hA1 uses the contact address of the UE received during registration as the Request-URI.

Route: The routes in the Record-Route header field are used as the route set.

Event: The S-CSCF-hA1 adds the Event header field containing the "reg" value.

Subscription-State: The S-CSCF-hA1 adds the Subscription-State header field set to "active" and indicates the expiration time in the "expires" header field parameter.

P-Charging-Vector: The S-CSCF-hA1 adds the P-Charging-Vector header field containing a new ICID value and the "ioi-orig" header field parameter set to a type 1 IOI value (i.e. home-A).

Via: The S-CSCF-hA1 adds a Via header field.

Content-Type: The S-CSCF-hA1 sets the value of the Content-Type header field to "application/reginfo+xml".

13. NOTIFY request (IBCF-hA1 to IC-A1) – see example in table 5.2.3.2-13.

The IBCF-hA1 sends the NOTIFY request according to 3GPP TS 24.229 [4] to the IC-A1.

NOTE 3: If the subsequent interconnection network is SIP-unaware, the IBCF-hA1 sends the NOTIFY request according to 3GPP TS 24.229 [4] to the IBCF-vA1 (not reflected in message details below).

Table 5.2.3.2-13: NOTIFY request (IBCF-hA1 to IC-A1)

<pre> NOTIFY sip:[5555::aaa:bbb:ccc:ddd] SIP/2.0 To: From: Route:<sip:ic-A1.interconnection-A.net;lr>,<sip:ibcf-vA1.visited-A.net;lr>,<sip:pcscf-vA1.visited-A.net;lr> Record-Route: <sip:ibcf-hA1.home-A.net:5070;lr> Call-ID: CSeq: Contact: Event: Subscription-State: P-Charging-Vector: Via:SIP/2.0/UDP ibcf-hA1.home-A.net;branch=z9hG4bK23456.2 Via:SIP/2.0/UDP scscf-hA1.home-A.net;branch=z9hG4bK23456.1 Content-Type: Content-Length: (...) For an example of the content of the SDP application/reginfo+xml see 3GPP TS 24.229 [4] subclause 5.4.2.1.2. Other SIP header fields are set according to 3GPP TS 24.229 [4]. </pre>
--

Record-Route: The IBCF-hA1 adds a Record-Route header field.

Via: Based on topology hiding functionality the IBCF-hA1 will either forward the Via header field with:

- one visible IBCF-hA1 entry and the remaining collected entries as one hidden entry; or
- an IBCF-hA1 entry and whole content of already collected entries as visible entries.

14. NOTIFY request (IC-A1 to IBCF-vA1) – see example in table 5.2.3.2-14.

NOTE 4: If the interconnection network is SIP-unaware, step 14 is skipped (not reflected in message details below).

The IC-A1 sends the NOTIFY request according to 3GPP TS 24.229 [4] to the IBCF-vA1.

Table 5.2.3.2-14: NOTIFY request (IC-A1 to IBCF-vA1)

<pre> NOTIFY sip:[5555::aaa:bbb:ccc:ddd] SIP/2.0 To: From: Route:<sip:ibcf-vA1.visited-A.net;lr>,<sip:pcscf-vA1.visited-A.net;lr> Record-Route: <sip:ic-A1.interconnection-A.net;lr>,<sip:ibcf-hA1.home-A.net:5070;lr> Call-ID: CSeq: Contact: Event: Subscription-State: P-Charging-Vector: icid-value="AyretyU0dm+602IrT5tAFrbHLso=45678901";orig-ioi="Type lhome-a";transit-ioi="ICa.1" Via: SIP/2.0/UDP ic-A1.interconnection-A.net;branch=z9hG4bK23456.3 Via: SIP/2.0/UDP ibcf-hA1.home-A.net;branch=z9hG4bK23456.2 Via: SIP/2.0/UDP scscf-hA1.home-A.net;branch=z9hG4bK23456.1 Content-Type: Content-Length: (...) For an example of the content of the SDP application/reginfo+xml see 3GPP TS 24.229 [4] subclause 5.4.2.1.2. Other SIP header fields are set according to 3GPP TS 24.229 [4]. </pre>

P-Charging-Vector: The IC-A1 adds the "transit-ioi" header field parameter identifying the interconnection network (i.e. ICa.1).

Record-Route: The IC-A1 adds a Record-Route header field.

Via: The IC-A1 adds a Via header field.

15. NOTIFY request (IBCF-vA1 to P-CSCF-vA1) – see example in table 5.2.3.2-15.

The IBCF-vA1 sends the NOTIFY request according to 3GPP TS 24.229 [4] to the P-CSCF-vA1.

In this example, the IBCF-vA1 does not add any "transit-oi" header field parameter in the P-Charging-Vector header field. However, the IBCF-vA1 adds the "transit-oi" header field parameter based on local policy, when the "transit-oi" identifying the preceding interconnection network is not included in the received request (e.g. when the preceding interconnection network is not an IMS transit network).

Table 5.2.3.2-15: NOTIFY request (IBCF-vA1 to P-CSCF-vA1)

<pre> NOTIFY sip:[5555::aaa:bbb:ccc:ddd] SIP/2.0 To: From: Route:<sip:pcscf-vA1.visited-A.net;lr> Record-Route:<sip:ibcf-vA1.visited-A.net:5070;lr>,<sip:ic-A1.interconnection-A.net;lr>,<sip:ibcf- hA1.home-A.net:5070;lr> Call-ID: CSeq: Contact: Event: Subscription-State: P-Charging-Vector: Via: SIP/2.0/UDP ibcf-vA1.visited-A.net;branch=z9hG4bK23456.4 Via: SIP/2.0/UDP ic-A1.interconnection-A.net;branch=z9hG4bK23456.3 Via: SIP/2.0/UDP ibcf-hA1.home-A.net;branch=z9hG4bK23456.2 Via: SIP/2.0/UDP scscf-hA1.home-A.net;branch=z9hG4bK23456.1 Content-Type: Content-Length: (...) For an example of the content of the SDP application/reginfo+xml see 3GPP TS 24.229 [4] subclause 5.4.2.1.2. Other SIP header fields are set according to 3GPP TS 24.229 [4]. </pre>
--

Record-Route: The IBCF-vA1 adds a Record-Route header field.

Via: The IBCF-vA1 adds a Via header field.

16. NOTIFY request (P-CSCF-vA1 to UE-A) – see example in table 5.2.3.2-16.

The P-CSCF-vA1 removes the protocol elements that cannot be sent to outside the trust domain (e.g. the P-Charging-Vector) and sends the NOTIFY request according to 3GPP TS 24.229 [4] to the UE-A.

Table 5.2.3.2-16: NOTIFY request (P-CSCF-vA1 to UE-A)

```

NOTIFY sip:[5555::aaa:bbb:ccc:ddd] SIP/2.0
To:
From:
Record-Route:<sip:p-cscf-vA1.visited-A.net:5070;lr>,<sip:ibcf-vA1.visited-A.net:5070;lr>,<sip:ic-
A1.interconnection-A.net;lr>,<sip:ibcf-hA1.home-A.net:5070;lr>
Call-ID:
CSeq:
Contact:
Event:
Subscription-State:

Via: SIP/2.0/UDP pcscf-vA1.visited-A.net;branch=z9hG4bK23456.5
Via: SIP/2.0/UDP ibcf-vA1.visited-A.net;branch=z9hG4bK23456.4
Via: SIP/2.0/UDP ic-A1.interconnection-A.net;branch=z9hG4bK23456.3
Via: SIP/2.0/UDP ibcf-hA1.home-A.net;branch=z9hG4bK23456.2
Via: SIP/2.0/UDP scscf-hA1.home-A.net;branch=z9hG4bK23456.1

Content-Type:
Content-Length: (...)

For an example of the content of the SDP application/reginfo+xml see 3GPP TS 24.229 [4] subclause
5.4.2.1.2.

Other SIP header fields are set according to 3GPP TS 24.229 [4].

```

Record-Route: The P-CSCF-vA1 adds a Record-Route header field.

Via: The P-CSCF-vA1 adds a Via header field.

17-21. 200 (OK) response (UE-A to S-CSCF-hA1).

The UE-A acknowledges the receipt of the NOTIFY request where:

- the P-CSCF-vA1 includes a P-Charging-Vector header field containing the same ICID value and "orig-ioi" header field parameter as received in the NOTIFY request. In addition the P-CSCF-vA1 adds the "term-ioi" header field parameter with the IOI value set to a value identifying the visited network A (i.e. visited-a).
- the IC-A1 adds to the P-Charging-Vector header field the "transit-ioi" set to a value identifying the interconnection network (i.e. ICa.1).

NOTE 5: If the interconnection network is SIP-unaware, step 20 is skipped.

5.2.3.3 The P-CSCF subscribes to the registration-state event package

After that the registration in clause 5.2.2 is successfully completed the P-CSCF-vA1 subscribes to the registration-state event package as described in 3GPP TS 24.229 [4] clause 5.2.3.

The information received in the registration-state event package can be used by the P-CSCF to determine if a registration is still valid.

Figure 5.2.3.3-1 shows how the P-CSCF-vA1 sends the SUBSCRIBE request without using the registration path hence it will appear as the SUBSCRIBE request is sent between two home networks.

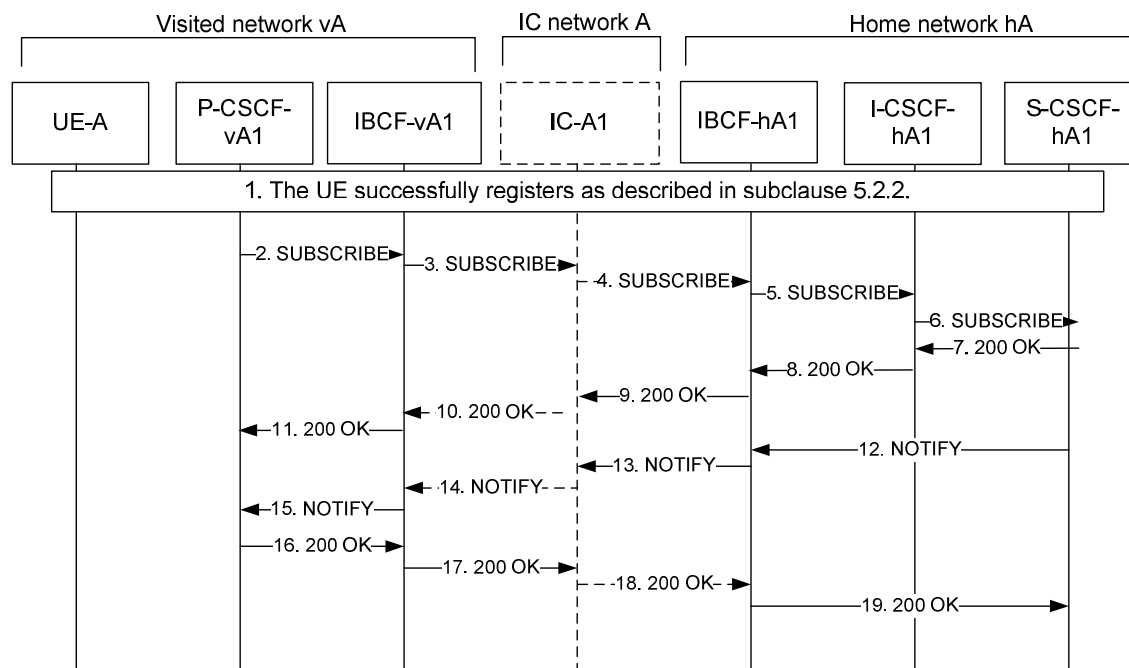

Figure 5.2.3.3-1: Subscription to the registration-state event package by the P-CSCF-vA1

The steps of the flow are as follows:

1. The UE successfully registers as described in clause 5.2.2.
2. **SUBSCRIBE** request (P-CSCF-vA1 to IBCF-vA1) - see example in table 5.2.3.3-2.

When the registration is successfully completed, i.e. the 200 (OK) to the REGISTER request sent is to the UE-A) the P-CSCF-vA1 subscribes to the registration-state event package in the home network hA.

The P-CSCF-vA1 selects an IBCF (IBCF-vA1) to be the IBCF acting as the exit point towards the home network hA and forwards a SUBSCRIBE request according to 3GPP TS 24.229 [4] to the IBCF-vA1.

Table 5.2.3.3-2: SUBSCRIBE request (P-CSCF-vA1 to IBCF-vA1)

```
SUBSCRIBE sip:userA_public1@home-A.net;iotl=visitedA-homeA SIP/2.0

From:<sip:p-cscf@visited-A.net>;tag=4ea2
To:<sip:userA_public1@home-A.net>
P-Asserted-Identity: <sip:visit-xyz@pcscf-vA1.visited-A.net>
Route: <sip:ibcf-vA1.visited-A.net;lr>
Contact:<sip:[5555::ddd:aaa:ccc:bbb]>
CSeq: 36 SUBSCRIBE
Event:reg
Expires:600000
Accept:application/reginfo+xml
P-Access-Network-Info:3GPP-E-UTRAN-TDD; utran-cell-id-3gpp=234151D0FCE11;network-provided;local-
time-zone="UTC+01:00";daylight-saving-time="01"
P-Charging-Vector: icid-value="AyretyU0dm+602IrT5tAFrbHLso=5467327";orig-ioi="Type lvisited-a"

Via: SIP/2.0/UDP [5555::ddd:aaa:ccc:bbb];branch=z9hG4bKnas12baad

Other SIP header fields are set according to 3GPP TS 24.229 [4].
```

- Request-URI:** Set to the default public user identity of the user, i.e. userA_public1@home-A.net. P-CSCF appends traffic leg information in the "iotl" SIP URI parameter according to IETF RFC 7549 [26].
- From:** Set to the P-CSCF's SIP URI.
- To:** Set to the SIP URI that is the default public user identity of the user i.e. userA_public1@home-A.net.

- P-Asserted-Identity:** Set to the value of the received "+g.3gpp.thig-path" Feature-Caps header field parameter if the received 200 (OK) response to the REGISTER request contained a "+g.3gpp.thig-path" Feature-Caps header field parameter or otherwise, as shown in this example, to the SIP URI of the P-CSCF, which was inserted into the Path header field during the registration of the user to whose registration state the P-CSCF subscribes to.
- Event:** The value of the Event header field is set to the value "reg" to specify the use of the registration state package.
- Accept:** The value of the Accept header field is set to "application/reginfo+xml".
- P-Access-Network-Info:** The P-CSCF adds the P-Access-Network-Info header field with a network provided location and daylight saving information.
- P-Charging-Vector:** The P-CSCF-vA1 includes an ICID value and a type 1 "orig-ioi" header field parameter. The P-CSCF-vA1 shall set the type 1 "orig-ioi" header field parameter to a value that identifies the sending network of the request (i.e. visited-A).

3. SUBSCRIBE request (IBCF-vA1 to IC-A1) - see example in table 5.2.3.3-3.

When the IBCF-vA1 receives the SUBSCRIBE request the IBCF-vA1 selects, based on local policy, to route the SUBSCRIBE request via IC network A and sends the SUBSCRIBE request according to 3GPP TS 24.229 [4] to the IC-A1. The IBCF-vA1 determines the next hop IP address from the URI in the first entry of the Route header field either by configured information or using a DNS query according to IETF RFC 3263 [13]. If the subsequent interconnection network is SIP-aware, the determined IP address will belong to the SIP proxy IC-A1. Otherwise the determined IP address will point to IBCF-hA1 and step 4 is skipped (not reflected in message details below).

Table 5.2.3.3-3: SUBSCRIBE request (IBCF-vA1 to IC-A1)

SUBSCRIBE sip:userA_public1@home-A.net;iotl=visitedA-homeA SIP/2.0	
From:	
To:	
P-Asserted-Identity:	
Route:	<sip:ic-A1.interconnection-A.net;lr>
Record-Route:	<sip:ibcf-vA1.visited-A.net;lr>
Contact:	
CSeq:	
Event:	
Expires:	
Accept:	
P-Access-Network-Info:	
P-Charging-Vector:	
Via:	SIP/2.0/UDP ibcf-vA1.visited-A.net;branch=z9hG4bKnas12baad.1
Via:	SIP/2.0/UDP [5555::ddd:aaa:ccc:bbb];branch=z9hG4bKnas12baad
Other SIP header fields are set according to 3GPP TS 24.229 [4].	

- Route:** The IBCF-vA1 adds a Route header field identifying the selected node in the IC network A.
- Record-Route:** The IBCF-vA1 adds a Record-Route header field.
- Via:** Based on topology hiding functionality the IBCF-vA1 will either forward the Via header field with:
- one visible IBCF-vA1 entry and the remaining collected entries as one hidden entry; or
 - one IBCF-vA1 entry and the whole content of already collected entries as visible entries.

4. SUBSCRIBE request (IC-A1 - to IBCF-hA1) - see example in table 5.2.3.3-4.

NOTE 1: If the interconnection network is SIP-unaware, step 4 is skipped (not reflected in message details below).

The IC-A1 selects an entry point (IBCF-hA1) of the home network hA and sends the SUBSCRIBE request according to 3GPP TS 24.229 [4] to the IBCF-hA1.

The IC-A1 may add a Route header field entry pointing to the entry point of home network hA. This is shown in example in table 5.3.3.3-4.

Table 5.2.3.3-4: SUBSCRIBE request (IC-A1 - to IBCF-hA1)

```

SUBSCRIBE sip:userA_public1@home-A.net;iotl=visitedA-homeA SIP/2.0

From:
To:
P-Asserted-Identity:
Route: <sip:ibcf-hA1.home-A.net;lr>
Record-Route:<sip:ic-A1.interconnection-A.net;lr>,<sip:ibcf-vA1.visited-A.net;lr>
Contact:
CSeq:
Event:
Expires:
Accept:
P-Charging-Vector: icid-value="AyretyU0dm+602IrT5tAFrbHLso=5467327";orig-ioi="Type lvisited-
a";transit-ioi="ICa.1"
P-Charging-Vector:

Via: SIP/2.0/UDP ic-A1.interconnection-A.net;branch=z9hG4bKnas12baad.2
Via: SIP/2.0/UDP ibcf-vA1.visited-A.net;branch=z9hG4bKnas12baad.1
Via: SIP/2.0/UDP [5555::ddd:aaa:ccc:bbb];branch=z9hG4bKnas12baad

Other SIP header fields are set according to 3GPP TS 24.229 [4].

```

P-Charging-Vector: The IC-A1 adds the "transit-ioi" header field parameter identifying the interconnection network (i.e. ICa.1).

Route: The IC-A1 adds a Route header field identifying the selected entry point in the home network hA.

Record-Route: Based on interconnection operator SLA the IC-A1 adds an entry to the Record-Route header field or not.

Via: The IC-A1 adds a Via header field.

5. SUBSCRIBE request (IBCF-hA1 to I-CSCF-hA1) - see example in table 5.2.3.3-5.

The IBCF-hA1 receives the SUBSCRIBE request and analyses the request line and the request to the I-CSCF-hA1. The IBCF-hA1 adds a Route header field with the address of the I-CSCF-hA1 of the home network of user A.

In this example, the IBCF-hA1 does not add any "transit-ioi" header field parameter in the P-Charging-Vector header field. However, the IBCF-hA1 adds the "transit-ioi" header field parameter based on local policy, when the "transit-ioi" identifying the preceding interconnection network is not included in the received request (e.g. when the preceding interconnection network is not an IMS transit network).

Table 5.2.3.3-5: SUBSCRIBE request (IBCF-hA1 to I-CSCF-hA1)

```

SUBSCRIBE sip:userA_public1@home-A.net;iotl=visitedA-homeA SIP/2.0

From:
To:
P-Asserted-Identity:
Route: <sip:icscf-hA1.home-A.net;lr>
Record-Route:<sip:ibcf-hA1.home-A.net;lr>,<sip:ic-A1.interconnection-A.net;lr>,<sip:ibcf-
vA1.visited-A.net;lr>
Contact:
CSeq:
Event:
Expires:
Accept:
P-Access-Network-Info:
P-Charging-Vector:

Via: SIP/2.0/UDP ibcf-hA1.home-A.net;branch=z9hG4bKnas12baad.3
Via: SIP/2.0/UDP ic-A1.interconnection-A.net;branch=z9hG4bKnas12baad.2
Via: SIP/2.0/UDP ibcf-vA1.visited-A.net;branch=z9hG4bKnas12baad.1
Via: SIP/2.0/UDP [5555::ddd:aaa:ccc:bbb];branch=z9hG4bKnas12baad

Other SIP header fields are set according to 3GPP TS 24.229 [4].

```

Via: The IBCF-hA1 adds a Via header field.

Route: The IBCF-hA1 adds a Route header field with the address of the I-CSCF-hA1 of the home network of user A.

Record-Route: The IBCF-hA1 adds a Record-Route header field.

6. SUBSCRIBE request (I-CSCF-hA1 to S-CSCF-hA1) - see example in table 5.2.3.3-6.

The I-CSCF-hA1 receives the SUBSCRIBE request and makes a request for information related to the subscriber registration status by sending the public user identity and visited domain name to the HSS. The HSS returns the S-CSCF address.

Due to the fact that the I-CSCF-hA1 only identifies the home S-CSCF which is responsible for the roaming user A, the I-CSCF-hA1 is not needed for future requests to be kept in the path, thus an I-CSCF entry is not needed within the Record-Route header field.

But for the response to the SUBSCRIBE request the I-CSCF-hA1 has to be added in the Via header field.

Table 5.2.3.3-6: SUBSCRIBE request (I-CSCF-hA1 to S-CSCF-hA1)

```
SUBSCRIBE sip:userA_public1@home-A.net;iotl=visitedA-homeA SIP/2.0

From:
To:
P-Asserted-Identity:
Route: <sip:home-abc@scscf-hA1.home-A.net;lr>
Record-Route:<sip:ibcf-hA1.home-A.net;lr>,<sip:ic-A1.interconnection-A.net;lr>,<sip:ibcf-
vA1.visited-A.net;lr>
Contact:
CSeq:
Event:
Expires:
Accept:
P-Access-Network-Info:
P-Charging-Vector:

Via: SIP/2.0/UDP icscf-hA1.home-A.net;branch=z9hG4bKnas12baad.4
Via: SIP/2.0/UDP ibcf-hA1.home-A.net;branch=z9hG4bKnas12baad.3
Via: SIP/2.0/UDP ic-A1.interconnection-A.net;branch=z9hG4bKnas12baad.2
Via: SIP/2.0/UDP ibcf-vA1.visited-A.net;branch=z9hG4bKnas12baad.1
Via: SIP/2.0/UDP [5555::ddd:aaa:ccc:bbb];branch=z9hG4bKnas12baad

Other SIP header fields are set according to 3GPP TS 24.229 [4].
```

Route: The I-CSCF-hA1 adds the address of the selected S-CSCF.

Via: The I-CSCF-hA1 adds a Via header field.

7-11. 200 (OK) response (S-CSCF to P-CSCF-vA1).

The S-CSCF-hA1 acknowledges a successful subscription to the registration-state event package where:

- the S-CSCF-hA1 includes a P-Charging-Vector header field containing the ICID value and "orig-ioi" header field parameter as received in the SUBSCRIBE request. In addition the S-CSCF-hA1 adds the "term-ioi" header field parameter with the IOI value set to a value identifying the home network A (i.e. home-a); and
- the IC-A1 adds to the P-Charging-Vector header field the "transit-ioi" set to a value identifying the interconnection network (i.e. "ICa.1").

NOTE 2: If the interconnection network is SIP-unaware, step 10 is skipped.

12. NOTIFY request (S-CSCF-hA1 to IBCF-hA1) - see example in table 5.2.3.3-12.

The S-CSCF-hA1 immediately after sending the 200 (OK) to the SUBSCRIBE request sends a NOTIFY request containing the registration-state event package in an application/reginfo+xml MIME body.

The NOTIFY request is sent along the path created by the routes received in the Record-Route header field.

Table 5.2.3.3-12: NOTIFY request (S-CSCF-hA1 to IBCF-hA1)

```

NOTIFY sip:[5555::ddd:aaa:ccc:bbb] SIP/2.0
To:<sip:visit-xyz@pcscf-vA1.visited-A.net>;tag=4ea2
From:<sip:userA_public1@home-A.net>;tag=3elf
Route:<sip:ibcf-hA1.home-A.net;lr>,<sip:ic-A1.interconnection-A.net;lr>,<sip:ibcf-vA1.visited-
A.net;lr>
CSeq:35 NOTIFY
Contact:<sip:[5555::aaa:ccc:eee:aaa]>

Event:reg
Subscription-State:active;expires=600000
P-Charging-Vector:icid-value="AyretyU0dm+6O2IrT5tAFrbHLso=45678901";orig-ioi="Type 1home-a"

Via: SIP/2.0/UDP [5555::aaa:ccc:eee:aaa];branch=z9hG4bK23456

Content-Type:application/reginfo+xml
Content-Length:(...)

For an example of the content of the SDP application/reginfo+xml see 3GPP TS 24.229 [4] subclause
5.4.2.1.2.

Other SIP header fields are set according to 3GPP TS 24.229 [4].

```

Request-URI:	Set to the contact address of the P-CSCF-vA1.
Route:	The routes in the Record-Route header field are used as the route set.
Event:	The S-CSCF-hA1 adds the Event header field containing the "reg" value.
Subscription-State:	The S-CSCF-hA1 adds the Subscription-State header field set to "active" and indicates the expiration time in the "expires" header field parameter.
P-Charging-Vector:	A new ICID value (i.e. different from the ICID value in the SUBSCRIBE request) and a type 1 "orig-ioi" header field parameter. The S-CSCF-hA1 shall set the type 1 "orig-ioi" header field parameter to a value that identifies the sending network of the request (i.e. home-A).
Via:	The S-CSCF-hA1 adds a Via header field.
Content-Type:	The S-CSCF-hA1 sets the value of the Content-Type header field to "application/reginfo+xml".

13. NOTIFY request (IBCF-hA1 to IC-A1) - see example in table 5.2.3.3-13.

The IBCF-hA1 sends the NOTIFY request according to 3GPP TS 24.229 [4] to the IC-A1.

NOTE 3: If the subsequent interconnection network is SIP-unaware, the IBCF-hA1 sends the NOTIFY request according to 3GPP TS 24.229 [4] to the IBCF-vA1 (not reflected in message details below).

Table 5.2.3.3-13: NOTIFY request (IBCF-hA1 to IC-A1)

```

NOTIFY sip:[5555::ddd:aaa:ccc:bbb] SIP/2.0
To:
From:
Route:<sip:ic-A1.interconnection-A.net;lr>,<sip:ibcf-vA1.visited-A.net;lr>
Record-Route:<sip:ibcf-hA1.home-A.net:5070;lr>
CSeq:
Contact:

Event:
Subscription-State:
P-Charging-Vector:

Via: SIP/2.0/UDP ibcf-hA1.home-A.net;branch=z9hG4bK23456.1

```

Via: SIP/2.0/UDP [5555::aaa:ccc:eee:aaa];branch=z9hG4bK23456

Content-Type:
Content-Length: (...)

For an example of the content of the SDP application/reginfo+xml see 3GPP TS 24.229 [4] subclause 5.4.2.1.2.

Other SIP header fields are set according to 3GPP TS 24.229 [4].

Record-Route: The IBCF-hA1 adds a Record-Route header field.

Via: Based on topology hiding functionality the IBCF-hA1 will either forward the Via header field with:

- one visible IBCF-hA1 entry and the remaining collected entries as one hidden entry; or
- one IBCF-hA1 entry and the whole content of already collected entries as visible entries.

14. NOTIFY request (IC-A1 to IBCF-vA1) - see example in table 5.2.3.3-14.

NOTE 4: If the interconnection network is SIP-unaware, step 14 is skipped (not reflected in message details below).

The IC-A1 sends the NOTIFY request according to 3GPP TS 24.229 [4] to the IBCF-vA1.

Table 5.2.3.3-14: NOTIFY request (IC-A1 to IBCF-vA1)

```
NOTIFY sip:[5555::ddd:aaa:ccc:bbb] SIP/2.0
To:
From:
Route:<sip:ibcf-vA1.visited-A.net;lr>
Record-Route:<sip:ic-A1.interconnection-A.net;lr>,<sip:ibcf-hA1.home-A.net:5070;lr>
CSeq:
Contact:
Event:
Subscription-State:
P-Charging-Vector:icid-value="AyretyU0dm+6O2IrT5tAFrbHLso=45678901";orig-ioi="Type lhome-a";transit-
ioi="ICa.1"

Via: SIP/2.0/UDP ic-A1.interconnection-A.net;branch=z9hG4bK23456.2
Via: SIP/2.0/UDP ibcf-hA1.home-A.net;branch=z9hG4bK23456.1
Via: SIP/2.0/UDP [5555::aaa:ccc:eee:aaa];branch=z9hG4bK23456

Content-Type:
Content-Length: (...)
```

For an example of the content of the SDP application/reginfo+xml see 3GPP TS 24.229 [4] subclause 5.4.2.1.2.

Other SIP header fields are set according to 3GPP TS 24.229 [4].

P-Charging-Vector: The IC-A1 adds the "transit-ioi" header field parameter identifying the interconnection network (i.e. ICa.1).

Record-Route: Based on interconnection operator SLA the IC-A1 adds an entry to the Record-Route header field or not.

Via: The IC-A1 adds a Via header field.

15. NOTIFY request (IBCF-vA1 to P-CSCF-vA1) - see example in table 5.2.3.3-15.

The IBCF-vA1 sends the NOTIFY request according to 3GPP TS 24.229 [4] to the P-CSCF-vA1.

In this example, the IBCF-vA1 does not add any "transit-ioi" header field parameter in the P-Charging-Vector header field. However, the IBCF-vA1 adds the "transit-ioi" header field parameter based on local policy, when the "transit-ioi" identifying the preceding interconnection network is not included in the received request (e.g. when the preceding interconnection network is not an IMS transit network).

Table 5.2.3.3-15: NOTIFY request (IBCF-vA1 to P-CSCF-vA1)

```

NOTIFY sip:[5555::ddd:aaa:ccc:bbb] SIP/2.0
To:
From:
Record-Route:<sip:ibcf-vA1.visited-A.net;lr>,<sip:ic-A1.interconnection-A.net;lr>,<sip:ibcf-
hA1.home-A.net:5070;lr>
CSeq:
Contact:
Event:
Subscription-State:
P-Charging-Vector:

Via: SIP/2.0/UDP ibcf-vA1.visited-A.net;branch=z9hG4bK23456.3
Via: SIP/2.0/UDP ic-A1.interconnection-A.net;branch=z9hG4bK23456.2
Via: SIP/2.0/UDP ibcf-hA1.home-A.net;branch=z9hG4bK23456.1
Via: SIP/2.0/UDP [5555::aaa:ccc:eee:aaa];branch=z9hG4bK23456

Content-Type:
Content-Length:(...)

For an example of the content of the SDP application/reginfo+xml see 3GPP TS 24.229 [4] subclause
5.4.2.1.2.

Other SIP header fields are set according to 3GPP TS 24.229 [4].

```

Record-Route: The IBCF-vA1 adds a Record-Route header field entry.

Via: The IBCF-vA1 adds a Via header field.

16-19. 200 (OK) response (P-CSCF-vA1 to S-CSCF-hA1).

The P-CSCF-vA1 acknowledges the receipt of the NOTIFY request where:

- the P-CSCF-vA1 includes a P-Charging-Vector header field containing the ICID value and "orig-ioi" header field parameter as received in the NOTIFY request. In addition the P-CSCF-vA1 adds the "term-ioi" header field parameter with the IOI value set to a value identifying the visited network A (i.e. visited-a); and
- the IC-A1 adds to the P-Charging-Vector header field the "transit-ioi" set to a value identifying the interconnection network (i.e. ICa.1).

NOTE 5: If the interconnection network is SIP-unaware, step 18 is skipped.

5.3 Originating roaming without loopback

5.3.1 General

This clause describes routing from the originating visited network to the originating home network including the traversal of transit network between the visited and the originating home network.

5.3.2 Call flow

In this scenario the originating home network decides to route the media directly to the terminating home network. OMR is not executed.

Preconditions:

- the user A is registered to the home network hA via the visited operator vA network and the IC network A as described in clause 5.2. The IC network does not store any registration information; and
- the called user is located in another network either in PSTN or in IMS.

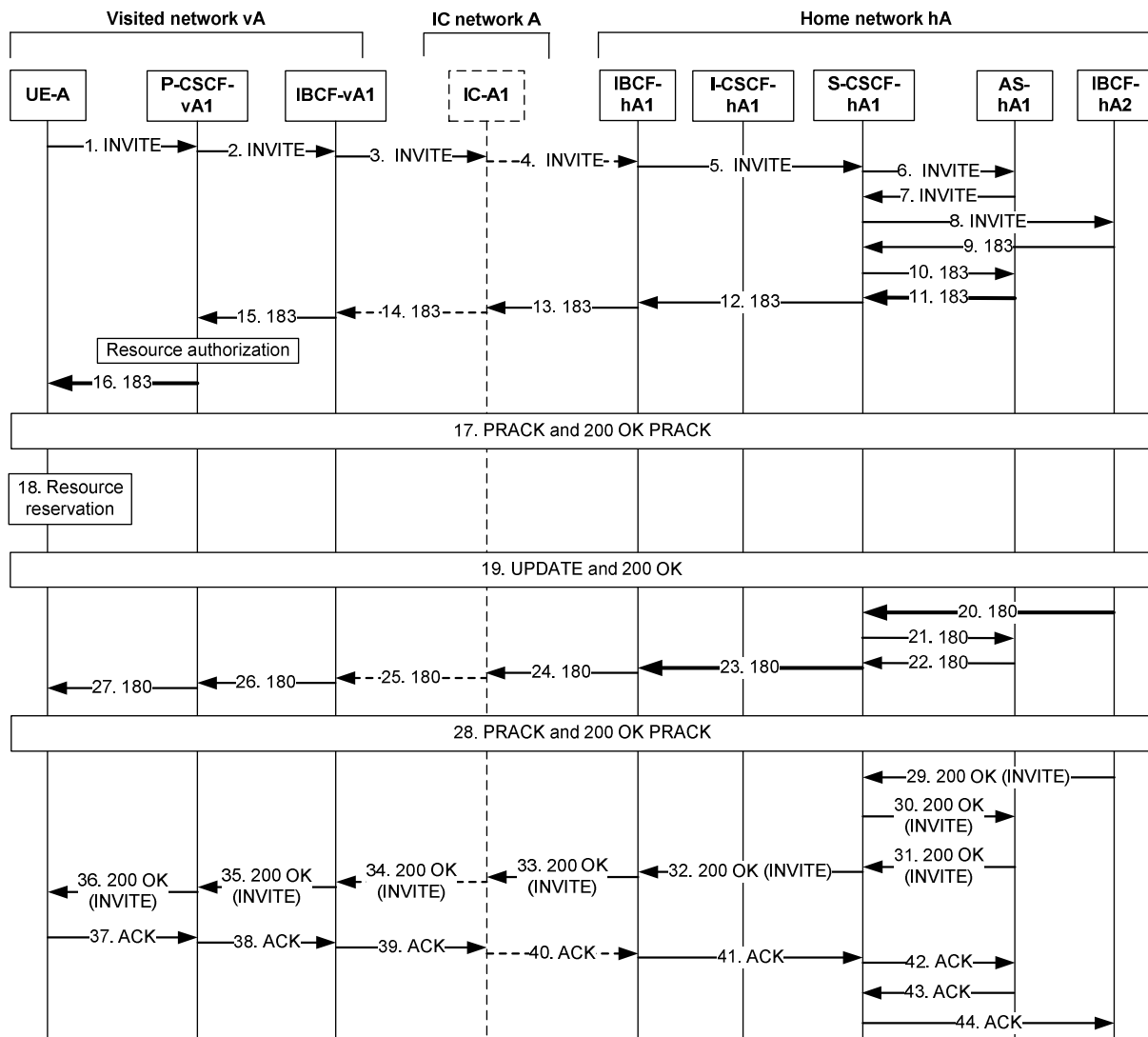

NOTE: For clarity, the SIP 100 (Trying) messages are not shown in the signalling flow.

Figure 5.3.2-1: MOC without loopback

The flow is based on the assumptions that the precondition mechanism is used and that the UE-A will indicate in the SDP offer sent within the INVITE request the related local preconditions for QoS as not met.

The steps of the flow are as follows:

1. INVITE request (UE-A to P-CSCF-vA1) - see example in table 5.3.2-1.

The user A at UE-A initiates a call. The UE-A sends an initial INVITE request to the P-CSCF-vA1 according to 3GPP TS 24.229 [4].

Table 5.3.2-1: INVITE request (UE-A to P-CSCF-vA1)

```
INVITE tel:+4687197378 SIP/2.0

To: <tel:+4687197378>
From: <sip:userA_public1@home-A.net>;tag=4fa3
P-Preferred-Identity: <sip:userA_public1@home-A.net>
P-Preferred-Service: urn:urn-7:3gpp-service.ims.icsi.mmtel
Contact: <sip:[5555::aaa:bbb:ccc:ddd]>
CSeq: 1 INVITE
Supported: 100rel, precondition, 199
Route: <sip:pcscf-vA1.visited-A.net;lr>, <sip:home-abc@scscf-hA1.home-A.net;lr;iotl=visitedA-homeA>
P-Access-Network-Info: 3GPP-E-UTRAN-TDD;utran-cell-id-3gpp=234151D0FCE11

Via: SIP/2.0/UDP [5555::aaa:bbb:ccc:ddd];branch=z9hG4bKnashds7
```

Other SIP header fields and SDP according to 3GPP TS 24.229 [4]

- P-Preferred-Identity:** The UE-A inserts the P-Preferred-Identity header field with value set to the default public user identity i.e. userA_public1@home-A.net.
- P-Preferred-Service:** The UE-A inserts the P-Preferred-Service header field with an ICSI value for a 3GPP defined IMS multimedia telephony communication service (MMTEL).
- Supported:** The UE-A inserts the Supported header field containing the option-tag "100rel", the option-tag "precondition" and the option-tag "199" indicating support of the reliable provisional responses, the precondition mechanism and the 199 (Early Dialog Terminated) provisional responses, respectively.
- Route:** The UE-A builds a proper preloaded route set for all new dialogs and standalone transactions containing the IP address or the FQDN learnt through the P-CSCF discovery procedures and the P-CSCF port based on the security mechanism in use. In addition the values received in the Service-Route header field saved from the 200 (OK) response to the last registration or re-registration of the public user identity with associated contact address are added (including traffic leg information in an "iotl" SIP URI parameter according to IETF RFC 7549 [26]). The content of the received Service-Route header field is due to operator policy. In this example only the S-CSCF-hA1 will be included.
- P-Access-Network-Info:** The UE-A provides the access-type and access-info, related to the serving access.
- Via:** The UE-A inserts a Via header field with the respective contact address where the UE-A expects to receive responses to the INVITE request.

2. INVITE request (P-CSCF-vA1 to IBCF-vA1) - see example in table 5.3.2-2.

When the P-CSCF-vA1 receives the initial INVITE request and, since the user A is a roaming user, based on local policy and roaming agreement the P-CSCF-vA1 adds the Feature-Caps header field with the "g.3gpp.trf" header field parameter with the address to the TRF.

The P-CSCF-vA1 selects an IBCF (IBCF-vA1) to be the exit IBCF towards the home IMS network hA of the user A and sends the INVITE request according to 3GPP TS 24.229 [4] to IBCF-v1A.

The received list of URIs in the Route header field within the INVITE will be verified with the Route header field list constructed from the Service-Route header field received during the last registration procedure.

Table 5.3.2-2: INVITE request (P-CSCF-vA1 to IBCF-vA1)

```
INVITE tel:+4687197378 SIP/2.0

To:
From:
P-Asserted-Identity: <sip:userA_public1@home-A.net>
P-Preferred-Service:
Contact:
CSeq:
Supported:
Route: <sip:ibcf-vA1.visited-A.net;lr>,<sip:home-abc@scscf-hA1.home-A.net;lr;iotl=visitedA-homeA>
Record-Route: <sip:pcscf-vA1.visited-A.net;lr>
Feature-Caps: *;+g.3gpp.trf="<sip:trf-vA1.visited-A.net;lr;iotl=homeA-visitedA>"
P-Access-Network-Info: 3GPP-E-UTRAN-TDD;utran-cell-id-3gpp=234151D0FCE11, 3GPP-E-UTRAN-TDD; utran-cell-id-3gpp=234151D0FCE11;network-provided;local-time-zone="UTC+01:00";daylight-saving-time="01"
P-Charging-Vector: icid-value="AyretyU0dm+602IrT5tAFrbHLso=023551024";orig-ioi="Type 1visited-a"

Via: SIP/2.0/UDP pcscf-vA1.visited-A.net:5060;branch=z9hG4bKnas56565
Via: SIP/2.0/UDP [5555::aaa:bbb:ccc:ddd];branch=z9hG4bKnashds7

Other SIP header fields and SDP according to 3GPP TS 24.229 [4].
```

- P-Asserted-Identity:** The value is set to the default public user identity i.e. userA_public1@home-A.net.
- P-Charging-Vector:** The P-CSCF-vA1 adds the P-Charging-Vector header field containing a new ICID value in the "icid" header field parameter and an "orig-ioi" header field parameter. The IOI value is of type 1 and identifies the visited network vA (i.e. visited-a).

- P-Access-Network-Info:** The P-CSCF-vA1 adds a network provided location and daylight saving time information. If the received P-Access-Network-Info header field doesn't indicate that it is a network provided location, the P-Access-Network-Info header field containing the location provided by the UE-A is kept in the INVITE request.
- Route:** The P-CSCF-vA1 verifies that the received route set corresponds to the route set received in the Service-Route header field and adds a Route header field identifying the selected IBCF-vA1.
- Record-Route:** The P-CSCF-vA1 adds a Record-Route header field.
- Via:** The P-CSCF-vA1 adds a Via header field.
- Feature-Caps:** The P-CSCF-vA1 adds a g.3gpp.trf feature-capability indicator in the Feature-Caps header field. The feature-capability indicator contains the address to a TRF-vA1 in the visited network and traffic leg information in an "iotl" SIP URI parameter according to IETF RFC 7549 [26]. This address is needed if the call will result in a loopback to the visited network.

3. INVITE request (IBCF-vA1 to IC-A1) - see example in table 5.3.2-3.

When the IBCF-vA1 receives the initial INVITE request containing the "+g.3gpp.trf" header field parameter in a Feature-Caps header field, the IBCF-vA1 updates the SDP as described within 3GPP TS 29.079 [5].

The IBCF-vA1 selects, based on local policy, to route the INVITE request via IC network A and sends the INVITE request according to 3GPP TS 24.229 [4] to the IC-A1. The IBCF-vA1 determines the next hop IP address from the URI in the first entry of the Route header field either by configured information or using a DNS query according to IETF RFC 3263 [13]. If the subsequent interconnection network is SIP-aware, the determined IP address will belong to the SIP proxy IC-A1. Otherwise the determined IP address will point to IBCF-hA1 and step 4 is skipped (not reflected in message details below).

Table 5.3.2-3: INVITE request (IBCF-vA1 to IC-A1)

<pre> INVITE tel:+4687197378 SIP/2.0 To: From: P-Asserted-Identity: P-Preferred-Service: Contact: CSeq: Supported: Route: <sip:ic-A1.interconnection-A.net;lr>,<sip:home-abc@scscf-hA1.home-A.net;lr;iotl=visitedA-homeA> Record-Route: <sip:ibcf-vA1.visited-A.net;lr>,<sip:pcscf-vA1.visited-A.net;lr> Feature-Caps: P-Access-Network-Info: P-Charging-Vector: Via: SIP/2.0/UDP ibcf-vA1.visited-A.net;branch=z9hG4bK351g45.1 Via: SIP/2.0/UDP pcscf-vA1.visited-A.net:5060;branch=z9hG4bKnas56565 Via: SIP/2.0/UDP [5555:aaa:bbb:ccc:ddd];branch=z9hG4bKnashds7 Other SIP header fields and SDP according to 3GPP TS 24.229 [4] and 3GPP TS 29.079 [5]. </pre>
--

- Route:** The IBCF-vA1 adds a Route header field identifying the selected node in the IC network A.
- Record-Route:** Based on topology hiding functionality the IBCF-vA1 will either forward the Record-Route header field with:
- one visible IBCF-vA1 entry and the remaining collected entries as one hidden entry; or
 - an IBCF-vA1 entry and whole content of already collected entries as visible entries.
- Via:** Based on topology hiding functionality the IBCF-vA1 will either forward the Via header field with:
- one visible IBCF-vA1 entry and the remaining collected entries as one hidden entry; or

- an IBCF-vA1 entry and whole content of already collected entries as visible entries.

4. INVITE request (IC-A1 to IBCF-hA1) - see example in table 5.3.2-4.

NOTE 1: If the interconnection network is SIP-unaware, step 4 is skipped (not reflected in message details below).

When the IC-A1 receives the initial INVITE request and since the IC-A1 according to local policy allows itself to be bypassed by media then the IC-A1 updates the SDP as described within 3GPP TS 29.079 [5].

The IC-A1 selects an entry point (IBCF-hA1) of the home IMS network hA and sends the INVITE request according to 3GPP TS 24.229 [4] to the IBCF-hA1.

The IC-A1 may add a Route header field entry pointing to the entry point of home network hA. This is shown in example in table 5.3.2-4.

Table 5.3.2-4: INVITE request (IC-A1 to IBCF-hA1)

```
INVITE tel:+4687197378 SIP/2.0

To:
From:
P-Asserted-Identity:
P-Preferred-Service:
Contact:
CSeq:
Supported:
Route: <sip:ibcf-hA1.home-A.net;lr>, <sip:home-abc@scscf-hA1.home-A.net;lr;iotl=visitedA-homeA>
Record-Route: <sip:ic-A1.interconnection-A.net;lr>, <sip:ibcf-vA1.visited-A.net;lr>,
  <sip:pcscf-vA1.visited-A.net;lr>
Feature-Caps:
P-Access-Network-Info:
P-Charging-Vector: icid-value="AyretyU0dm+602IrT5tAFrbHLso=023551024";orig-ioi="Type lvisited-a";
transit-ioi="ICa.1"

Via: SIP/2.0/UDP ic-A1.interconnection-A.net;branch=z9hG4bK351g45.2
Via: SIP/2.0/UDP ibcf-vA1.visited-A.net;branch=z9hG4bK351g45.1
Via: SIP/2.0/UDP pcscf-vA1.visited-A.net;5060;branch=z9hG4bKnas56565
Via: SIP/2.0/UDP [5555::aaa:bbb:ccc:ddd];branch=z9hG4bKnashds7

Other SIP header fields and SDP according to 3GPP TS 24.229 [4] and
3GPP TS 29.079 [5].
```

- P-Charging-Vector:** The IC-A1 adds the "transit-ioi" header field parameter identifying the interconnection network (i.e. ICa.1).
- Route:** The IC-A1 adds a Route header field identifying the selected entry point in the home network hA.
- Record-Route:** Based on interconnection operator SLA the IC-A1 adds an entry to the Record-Route header field or not.
- Via:** The IC-A1 adds a Via header field.

5. INVITE request (IBCF-hA1 to S-CSCF-hA1) - see example in table 5.3.2-5.

When the IBCF-hA1 receives the initial INVITE request containing the "+g.3gpp.trf" header field parameter in a Feature-Caps header field, the IBCF-hA1 updates the SDP as described in 3GPP TS 29.079 [5].

The IBCF-hA1 sends the INVITE request according to 3GPP TS 24.229 [4] to the S-CSCF-hA1.

In this example, the IBCF-hA1 does not add any "transit-ioi" header field parameter in the P-Charging-Vector header field. However, the IBCF-hA1 adds the "transit-ioi" header field parameter based on local policy, when the "transit-ioi" identifying the preceding interconnection network is not included in the received request (e.g. when the preceding interconnection network is not an IMS transit network).

Table 5.3.2-5: INVITE request (IBCF-hA1 to S-CSCF-hA1)

```
INVITE tel:+4687197378 SIP/2.0

To:
From:
```



```

P-Asserted-Identity:
P-Preferred-Service:
Contact:
CSeq:
Supported:
Route: <sip:home-abc@scscf-hA1.home-A.net;lr;iotl=visitedA-homeA>
Record-Route: <sip:ibcf-hA1.home-A.net:5070;lr>,<sip:ic-A1.interconnection-A.net;lr>,<sip:ibcf-vA1.visited-A.net;lr>,<sip:pcscf-vA1.visited-A.net;lr>
Feature-Caps:
P-Access-Network-Info:
P-Charging-Vector:

Via: SIP/2.0/UDP ibcf-hA1.home-A.net;branch=z9hG4bK351g45.3
Via: SIP/2.0/UDP ic-A1.interconnection-A.net;branch=z9hG4bK351g45.2
Via: SIP/2.0/UDP ibcf-vA1.visited-A.net;branch=z9hG4bK351g45.1
Via: SIP/2.0/UDP pcscf-vA1.visited-A.net:5060;branch=z9hG4bKnas56565
Via: SIP/2.0/UDP [5555::aaa:bbb:ccc:ddd];branch=z9hG4bKnashds7

Other SIP header fields and SDP according to 3GPP TS 24.229 [4] and 3GPP TS 29.079 [5].

```

Via: The IBCF-hA1 adds a Via header field.

Record-Route: The IBCF-hA1 adds a Record-Route header field.

6. INVITE request (S-CSCF-hA1 to AS-hA1) - see example in table 5.3.2-6.

The S-CSCF-hA1 applies first filter criteria that is no specific procedures due to roaming. The case where an AS needs the involvement of media function is described in clause 5.10.

The S-CSCF-hA1 decides according to local policy that loopback routing can be used and include a Feature-Caps header field according to IETF RFC 6809 [21] with the "+g.3gpp.home-visited" header field parameter set to the identifier of the visited network received in the P-Visited-Network-ID header field in the original registration request.

The S-CSCF-hA1 replaces the received "orig-ioi" header field parameter value in the P-Charging-Vector header field with the type 3 "orig-ioi" header field parameter with a value identifying the home network hA (i.e. "home-a").

If a service needs to be invoked according to the user A profile, a Route header field with an URI pointing to the AS-hA1 and the URI pointing back to the S-CSCF-hA1 is added.

Table 5.3.2-6: INVITE request (S-CSCF-hA1 to AS-hA1)

```

INVITE tel:+4687197378 SIP/2.0

To:
From:
P-Asserted-Identity:
P-Asserted-Service: urn:urn-7:3gpp-service.ims.icsi.mmtel
Contact:
CSeq:
Supported:
Route: <sip:as-hA1.home-A.net;lr>,<sip:orig@scscf-hA1.home-A.net;lr>
Record-Route: <sip:scscf-hA1.home-A.net:5070;lr>,<sip:ibcf-hA1.home-A.net:5070;lr>,<sip:ic-A1.interconnection-A.net;lr>,<sip:ibcf-vA1.visited-A.net;lr>,<sip:pcscf-vA1.visited-A.net;lr>
Feature-Caps: *;+g.3gpp.home-visited="<visited-A>";+g.3gpp.trf="<sip:trf-vA1.visited-A.net;lr;iotl=homeA-visitedA>"
P-Access-Network-Info:
P-Charging-Vector: icid-value="AyretyU0dm+602IrT5tAFrbHLso=023551024";orig-ioi="Type 3home-a"
Relayed-Charge: SCSCF:transit-ioi="ICa.1"

Via: SIP/2.0/UDP scscf-hA1.home-A.net;branch=z9hG4bK351g45.4
Via: SIP/2.0/UDP ibcf-hA1.home-A.net;branch=z9hG4bK351g45.3
Via: SIP/2.0/UDP ic-A1.interconnection-A.net;branch=z9hG4bK351g45.2
Via: SIP/2.0/UDP ibcf-vA1.visited-A.net;branch=z9hG4bK351g45.1
Via: SIP/2.0/UDP pcscf-vA1.visited-A.net:5060;branch=z9hG4bKnas56565
Via: SIP/2.0/UDP [5555::aaa:bbb:ccc:ddd];branch=z9hG4bKnashds7

Other SIP header fields and SDP according to 3GPP TS 24.229 [4] and 3GPP TS 29.079 [5].

```

Route: The S-CSCF-hA1 adds Route header field with an URI pointing to the AS-hA1 and the URI pointing back to the S-CSCF-hA1.

- P-Charging-Vector:** The S-CSCF-hA1 replaces the type 1 IOI values received in the "orig-ioi" header field parameter with a type 3 IOI value identifying the home network hA.
- Relayed-Charge:** The S-CSCF adds the "relayed" header field parameter set to the value of the "transit-ioi" header field parameter received in the INVITE request from the IBCF-Ah1. S-CSCF is set as the source.
- Via:** The S-CSCF-hA1 adds a Via header field.
- Record-Route:** The S-CSCF-hA1 adds a Record-Route header field.
- Feature-Caps:** Since loopback is possible the S-CSCF-hA1 adds the g.3gpp.home-visited feature capability indicator in the Feature-Caps header field.

7. INVITE request (AS-hA1 to S-CSCF-hA1) - see example in table 5.3.2-7.

AS-hA1 applies the service and removes the first Route header field entry.

The AS-hA1 shall remove the "orig-ioi" header field parameter from the forwarded request and insert a type 3 "orig-ioi" header field parameter. The AS-hA1 shall set the type 3 "orig-ioi" header field parameter to the IOI value that identifies the service provider from which the request is sent. In this example the IOI value is the same as the home network operator identity.

The specifics of the service provided by the AS-hA1 require access to the media and the AS-hA1 removes the "+g.3gpp.home-visited" Feature-Caps header field parameter. The absence of the "+g.3gpp.home-visited" Feature-Caps header field parameter is an indication to S-CSCF-hA1 that a loopback routing is not a viable option.

NOTE 2: The AS can either keep the OMR attributes in SDP or remove them depending on if the AS supports OMR and local policy. In this example it is assumed that the AS removes the OMR attributes.

All other SIP headers are set due to procedures described within 3GPP TS 24.229 [4].

Table 5.3.2-7: INVITE request (AS-hA1 to S-CSCF-hA1)

<pre> INVITE tel:+4687197378 SIP/2.0 To: From: P-Asserted-Identity: P-Asserted-Service: Contact: CSeq: Supported: Route: <sip:orig@scscf-hA1.home-A.net;lr> Record-Route: <sip:as-hA1.home-A.net:5070;lr>,<sip:scscf-hA1.home-A.net:5070;lr>,<sip:ibcf-hA1.home-A.net:5070;lr>,<sip:ic-A1.interconnection-A.net;lr>,<sip:ibcf-vA1.visited-A.net;lr>,<sip:pcscf-vA1.visited-A.net;lr> Feature-Caps: *;+g.3gpp.trf="<sip:trf-vA1.visited-A.net;lr;iotl=homeA-visitedA>" P-Access-Network-Info: P-Charging-Vector: icid-value="AyretyU0dm+602IrT5tAFrbHLso=023551024";orig-ioi="Type 3home-a" Relayed-Charge: Via: SIP/2.0/UDP as-hA1.home-A.net;branch=z9hG4bK351g45.5 Via: SIP/2.0/UDP scscf-hA1.home-A.net;branch=z9hG4bK351g45.4 Via: SIP/2.0/UDP ibcf-hA1.home-A.net;branch=z9hG4bK351g45.3 Via: SIP/2.0/UDP ic-A1.interconnection-A.net;branch=z9hG4bK351g45.2 Via: SIP/2.0/UDP ibcf-vA1.visited-A.net;branch=z9hG4bK351g45.1 Via: SIP/2.0/UDP pcscf-vA1.visited-A.net:5060;branch=z9hG4bKnas56565 Via: SIP/2.0/UDP [5555::aaa:bbb:ccc:ddd];branch=z9hG4bKnashds7 Other SIP header fields and SDP according to 3GPP TS 24.229 [4] and 3GPP TS 29.079 [5]. </pre>
--

- P-Charging-Vector:** The AS-hA1 replaces the "orig-ioi" header field parameter. The AS-hA1 sets the type 3 "orig-ioi" header field parameter to a value that identifies the sending network (in the example the AS-hA1 belongs to the same network as the S-CSCF-hA1 and thus the value is the same as the IOI value received from S-CSCF-hA1, i.e. "home-a"). The AS has to set itself a type 3 IOI if the AS is located within another domain (i.e. a 3rd party service provider). If more than one AS is within the path the "orig-ioi" header field parameter values could be changed based on the relation between S-CSCF-hA1 and the related AS.

Record-Route: The entries to this header field need to be added based on the related dip's to the AS. The AS could behave as B2BUA. In such case the AS could store the entries and setup a new Record-Route header field only with the AS URI as an entry.

Via: The AS-hA1 adds a Via header field.

8. INVITE request (S-CSCF-hA1 to IBCF-hA2) - see example in table 5.3.2-8.

When the S-CSCF-hA1 receives the initial INVITE request back from the AS-hA1 and if no further services apply then the S-CSCF-hA1 decides according to local policy if loopback routeing shall be used or not. In this use case loopback will not apply. The S-CSCF-hA1 removes the Feature-Caps header field "*;+g.3gpp.trf" from the INVITE request.

If the domain of the called user is not the same home domain as from the calling user then the S-CSCF-hA1 has to identify the home network of the called user via ENUM/DNS as provided by local policy of the operator.

If the ENUM/DNS request fails the call will be forwarded to the BGCF or if number portability applies and an rn parameter must be set up the call will be also forwarded to the BGCF. In the case the FQDN needs to be addressed to MGCF the INVITE request will be forwarded to the BGCF. In this use case the INVITE request is sent directly to IBCF-hA2.

The S-CSCF-hA1 replaces the received "orig-ioi" header field parameter value in the P-Charging-Vector header field with the type 2 "orig-ioi" header field parameter value identifying the home network hA (i.e. "home-a").

The Relayed-Charge header field is deleted.

Table 5.3.2-8: INVITE request (S-CSCF-hA1 to IBCF-hA2)

```
INVITE sip:+4687197378@home-R.net;user=phone;iotl=homeA-homeB SIP/2.0
To:
From:
P-Asserted-Identity:
P-Asserted-Service:
Contact:
CSeq:
Supported:
Route: <sip:ibcf-hA2.home-A.net;lr>
Record-Route: <sip:scscf-hA1.home-A.net:5070;lr>, <sip:as-hA1.home-A.net:5070;lr>,
<sip:scscf-hA1.home-A.net:5070;lr>, <sip:ibcf-hA1.home-A.net:5070;lr>,
<sip:ic-A1.interconnection-A.net;lr>, <sip:ibcf-vA1.visited-A.net;lr>,
<sip:pcscf-vA1.visited-A.net;lr>
P-Access-Network-Info:
P-Charging-Vector: icid-value="AyretyU0dm+602IrT5tAFrbHLso=023551024";orig-ioi="home-a"

Via: SIP/2.0/UDP scscf-hA1.home-A.net;branch=z9hG4bK351g45.6
Via: SIP/2.0/UDP as-hA1.home-A.net;branch=z9hG4bK351g45.5
Via: SIP/2.0/UDP scscf-hA1.home-A.net;branch=z9hG4bK351g45.4
Via: SIP/2.0/UDP ibcf-hA1.home-A.net;branch=z9hG4bK351g45.3
Via: SIP/2.0/UDP ic-A1.interconnection-A.net;branch=z9hG4bK351g45.2
Via: SIP/2.0/UDP ibcf-vA1.visited-A.net;branch=z9hG4bK351g45.1
Via: SIP/2.0/UDP pcscf-vA1.visited-A.net:5060;branch=z9hG4bKnas56565
Via: SIP/2.0/UDP [5555::aaa:bbb:ccc:ddd];branch=z9hG4bKnashds7

Other SIP header fields and SDP according to 3GPP TS 24.229 [4].
```

Request-URI: The S-CSCF converts the received tel URI to a SIP URI (e.g. by means of ENUM) and appends traffic leg information in an "iotl" SIP URI parameter according to IETF RFC 7549 [26].

Route: The S-CSCF-hA1 adds a Route header with the address of the selected IBCF-hA2.

Via: The S-CSCF-hA1 adds a Via header field.

Record-Route: The S-CSCF-hA1 adds a Record-Route header field.

P-Charging-Vector: The S-CSCF-hA1 replaces the received type 3 IOI received from the AS-hA1 with a type 2 IOI value (i.e. home-a).

9-16. 183 (Session Progress) response (IBCF-hA2 to UE-A via S-CSCF-hA1, AS-hA1, S-CSCF-hA1, IBCF-hA1, IC-A1, IBCF-vA1 and P-CSCF-vA1) - see example in table 5.3.2-9.

When the IBCF-hA2 receives the 183 (Session Progress) response the IBCF-hA2 sends the 183 (Session Progress) response according to 3GPP TS 24.229 [4] towards the UE-A via the S-CSCF-hA1, AS-hA1, IBCF-hA1, IC-A1, IBCF-vA1, P-CSCF-vA1 path as described within 3GPP TS 24.229 [4].

The table 5.3.2-9 shows the content of the 183 (Session Progress) response when sent by IBCF-hA2.

Table 5.3.2-9: SIP 183 (Session Progress) response (IBCF-hA2 to UE-A) in step 9

<pre> SIP/2.0 183 Session Progress To: <tel:+4687197378>;tag=654a From: <sip:userA_public1@home-A.net>;tag=4fa3 P-Asserted-Identity: <tel:+4687197378>,<sip:+4687197378@home-R.net;user=phone> Contact: <sip:[5555::bbb:ccc:ddd:aaa]> CSeq: 1 INVITE Require: 100rel, precondition Via: SIP/2.0/UDP scscf-hA1.home-A.net;branch=z9hG4bK351g45.6 Via: SIP/2.0/UDP as-hA1.home-A.net;branch=z9hG4bK351g45.5 Via: SIP/2.0/UDP scscf-hA1.home-A.net;branch=z9hG4bK351g45.4 Via: SIP/2.0/UDP ibcf-hA1.home-A.net;branch=z9hG4bK351g45.3 Via: SIP/2.0/UDP ic-A1.interconnection-A.net;branch=z9hG4bK351g45.2 Via: SIP/2.0/UDP ibcf-vA1.visited-A.net;branch=z9hG4bK351g45.1 Via: SIP/2.0/UDP pcscf-vA1.visited-A.net:5060;branch=z9hG4bK351g45.1 Via: SIP/2.0/UDP [5555::aaa:bbb:ccc:ddd];branch=z9hG4bK351g45.7 Record-Route: <One or more entries with entities of the terminating network>, <sip:ibcf-hA2.home-A.net:5070;lr>,<sip:scscf-hA1.home-A.net:5070;lr>, <sip:as-hA1.home-A.net:5070;lr>,<sip:scscf-hA1.home-A.net:5070;lr>, <sip:ibcf-hA1.interconnection-A.net:5070;lr>,<sip:ic-A1.interconnection-A.net;lr>, <sip:ibcf-vA1.visited-A.net;lr>,<sip:pcscf-vA1.visited-A.net;lr> P-Charging-Vector: icid-value="AyretyU0dm+602IrT5tAFrbHLso=023551024"; orig-ioi="home-a"; transit- ioi="Ict.1"; term-ioi="home-r" Other SIP header fields and SDP according to 3GPP TS 24.229 [4]. </pre>
--

Require: The Require header field contains the option-tag "100rel" indicating reliable sending of the 183 (Session Progress) response and the option-tag "precondition" indicating the usage of the precondition mechanism.

P-Charging-Vector: The settings of the IOI values are important:

- in step 9 the "term-ioi" header field parameter includes a type 2 IOI value which identifies the home network of the remote user (i.e. "home-r"). The "transit-ioi" header field parameter including one or more values identifying the transit networks passed. The "orig-ioi" header field parameter is set to the same type 2 IOI value that was included in the initial INVITE request by the home network hA (i.e. "home-a") towards the terminating user;
- in step 10 the "term-ioi" header field parameter includes a type 3 IOI value (prefix "Type 3") which identifies the S-CSCF-hA1 network. The "orig-ioi" header field parameter is set to the same type 3 IOI value that was included in the initial INVITE request from the AS-hA1 to the S-CSCF-hA1;
- in step 11 the "term-ioi" header field parameter includes a type 3 IOI value (prefix "Type 3") which identifies the AS-hA1 network. The "orig-ioi" header field parameter is set to the same type 3 IOI value that was included in the initial INVITE request from the S-CSCF-hA1 to the AS-hA1;
- in steps 12-15 the "term-ioi" header field parameter includes a type 1 IOI value (prefix "Type 1") which identifies the home network hA. The "orig-ioi" header field parameter is set to the same type 1 IOI value that was included in the initial INVITE request from the visited network vA towards the home network hA; and
- in steps 14-15 the "transit-ioi" header field parameter includes one or more values identifying the transit networks passed.

NOTE 3: If the interconnection network is SIP-unaware, step 14 is skipped.

17. PRACK requests (UE-A to IBCF-hA2 via P-CSCF-vA1, IBCF-vA1, IC-A1, IBCF-hA1, S-CSCF-hA1, AS-hA1 and S-CSCF-hA1) and SIP 200 (OK) response to the SIP PRACK request (IBCF-hA2 to UE-A via S-CSCF-hA1, AS-hA1, S-CSCF-hA1, IBCF-vA1, IC-A1, IBCF-hA1 and P-CSCF-vA1).

The PRACK request and the 200 (OK) response to the PRACK request are sent without any SDP offer/SDP answer between the UE-A and the IBCF-hA2 according to 3GPP TS 24.229 [4].

18. Resource reservation.

19. UPDATE requests (UE-A to IBCF-hA2 via P-CSCF-vA1, IBCF-vA1, IC-A1, IBCF-hA1, S-CSCF-hA1, AS-hA1 and S-CSCF-hA1) and SIP 200 (OK) response to the SIP UPDATE request (IBCF-hA2 to UE-A via S-CSCF-hA1, AS-hA1, S-CSCF-hA1, IBCF-hA1, IC-A1, IBCF-vA1 and P-CSCF-vA1).

After a local resource reservation the UE-A sends the UPDATE request with the SDP offer containing an indication that the local preconditions for QoS are fulfilled according to 3GPP TS 24.229 [4].

20-27. 180 (Ringing) response to the SIP INVITE request (IBCF-hA2 to UE-A via S-CSCF-hA1, AS-hA1, S-CSCF-hA1, IBCF-hA1, IC-A1, IBCF-vA1 and P-CSCF-vA1).

NOTE 4: If the interconnection network is SIP-unaware, step 25 is skipped.

28. PRACK requests (UE-A to IBCF-hA2 via P-CSCF-vA1, IBCF-vA1, IC-A1, IBCF-hA1, S-CSCF-hA1, AS-hA1 and S-CSCF-hA1) and SIP 200 (OK) response to the SIP PRACK request (IBCF-hA2 to UE-A via S-CSCF-hA1, AS-hA1, S-CSCF-hA1, IBCF-hA1, IC-A1, IBCF-vA1 and P-CSCF-vA1).

The PRACK request and the 200 (OK) response to the PRACK request are sent without any SDP offer/SDP answer between the UE-A and the IBCF-hA2 according to 3GPP TS 24.229 [4].

29-36. 200 (OK) response to the SIP INVITE request (IBCF-hA2 to UE-A via S-CSCF-hA1, AS-hA1, S-CSCF-hA1, IBCF-hA1, IC-A1, IBCF-vA1 and P-CSCF-vA1).

NOTE 5: If the interconnection network is SIP-unaware, step 34 is skipped.

37-44. ACK requests (UE-A to IBCF-hA2 via P-CSCF-vA1, IBCF-vA1, IC-A1, IBCF-hA1, S-CSCF-hA1, AS-hA1 and S-CSCF-hA1).

The UE-A sends the ACK request, which acknowledges the 200 (OK) final response, to the IBCF-hA2 according to 3GPP TS 24.229 [4].

NOTE 6: If the interconnection network is SIP-unaware, step 40 is skipped.

5.4 Originating roaming with loopback

5.4.1 General

This use case shows the loopback procedure that includes routeing from originating visited network to originating home network and loopback routeing from originating home network to originating visited network including the traversal of transit network between the visited and the originating home network.

Signalling is prepared to skip the loopback and route directly to the terminating home network on demand of the originating home network, see the use case provided by clause 5.3.

5.4.2 Call flow

In this scenario the originating home network decides to use loopback routeing and OMR is used.

Preconditions:

- the user A is registered to the home network hA via the visited operator vA network and the IC network A as described in clause 5.2. The IC network does not store any registration information;
- the called user is located in another network either in PSTN or in IMS;
- P-CSCF-vA1 and S-CSCF-hA1 support loopback routeing;

- IBCF-vA1, IBCF-hA1 and IC-A1 supports OMR and all networks supports loopback routing; and
- no B2BUA manipulating SDP is connected in the home operator hA network.

SDP behaviour for loopback including OMR is described within 3GPP TS 29.079 [5].

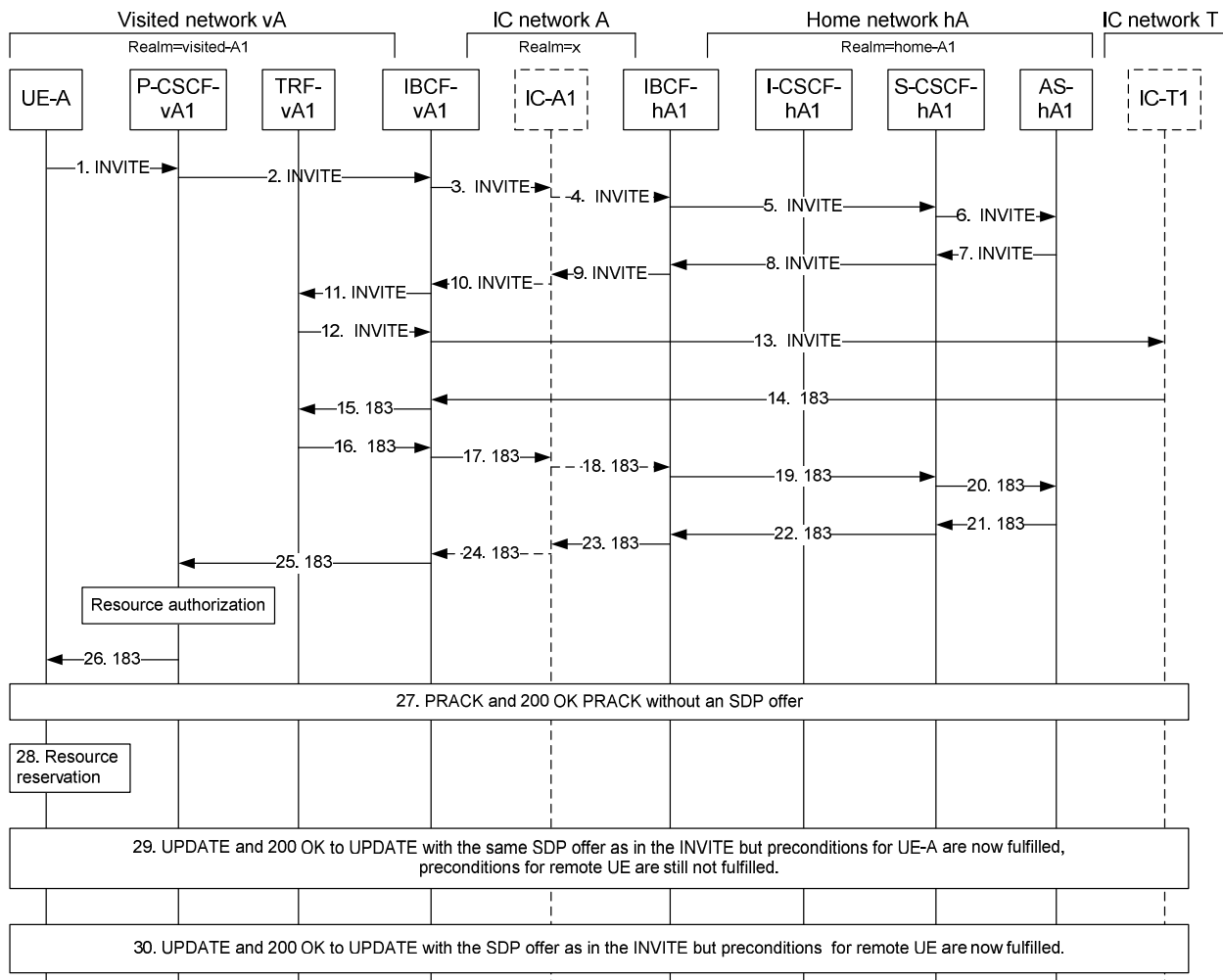

NOTE: For clarity, the SIP 100 (Trying) messages are not shown in the signalling flow.

Figure 5.4.2-1: MOC with loopback

The flow is based on the assumptions that the precondition mechanism is used and that the UE-A will indicate in the SDP offer sent within the INVITE request the related local preconditions for QoS as not met.

The steps of the flow are as follows:

1. INVITE request (UE-A to P-CSCF-vA1) - see example in table 5.4.2-1.

The user A at UE-A initiates a call. The UE-A sends an initial INVITE request to the P-CSCF-vA1 according to 3GPP TS 24.229 [4].

Table 5.4.2-1: INVITE request (UE-A to P-CSCF-vA1)

```
INVITE tel:+4687197378 SIP/2.0

To: <tel:+4687197378>
From: <sip:userA_public1@home-A.net>;tag=4fa3
P-Preferred-Identity: <sip:userA_public1@home-A.net>
P-Preferred-Service: urn:urn-7:3gpp-service.ims.icsi.mmmtel
Contact: <sip:[5555::aaa:bbb:ccc:ddd]>
CSeq: 1 INVITE
Supported: 100rel, precondition, 199
Route: <sip:pcscf-vA1.visited-A.net;lr>,<sip:home-abc@scscf-hA1.home-A.net;lr;iotl=visitedA-homeA >
```

```

P-Access-Network-Info: 3GPP-E-UTRAN-TDD; utran-cell-id-3gpp=234151D0FCE11

Via: SIP/2.0/UDP [5555::aaa:bbb:ccc:ddd];branch=z9hG4bKnashds7

Content-Type:application/sdp
Content-Length: (...)

c=IN IP6 [5555::aaa:bbb:ccc:ddd]
m=audio 16000 RTP/AVP 97 98
a=curr:qos local none
a=curr:qos remote none
a=des:qos mandatory local sendrecv
a=des:qos none remote sendrecv

Other SIP header fields and SDP according to 3GPP TS 24.229 [4].

```

- P-Preferred-Identity:** The UE-A inserts the P-Preferred-Identity header field with value set to the default public user identity i.e. userA_public1@home-A.net.
- P-Preferred-Service:** The UE-A inserts the P-Preferred-Service header field with an ICSI value for a 3GPP defined IMS multimedia telephony communication service (MMTEL).
- Supported:** The UE-A inserts the Supported header field containing the option-tag "100rel", the option-tag "precondition" and the option-tag "199" indicating support of the reliable provisional responses, the precondition mechanism and the 199 (Early Dialog Terminated) provisional responses, respectively.
- Route:** The UE-A builds a proper preloaded route set for all new dialogs and standalone transactions containing the IP address or the FQDN learnt through the P-CSCF discovery procedures and the P-CSCF port based on the security mechanism in use. In addition the values received in the Service-Route header field saved from the 200 (OK) response to the last registration or re-registration of the public user identity with associated contact address are added (including traffic leg information in an "iotl" SIP URI parameter according to IETF RFC 549 [26]). The content of the received Service-Route header field is due to operator policy. In this example only the S-CSCF-hA1 will be included.
- P-Access-Network-Info:** The UE-A provides the access-type and access-info, related to the serving access.
- Via:** The UE-A inserts a Via header field with the respective contact address where the UE-A expects to receive responses to the INVITE request.
- SDP:** The UE-A add necessary information in an SDP offer. For readability reasons only the parts of the SDP that will change due to the use of OMR is shown. The rest is as described in 3GPP TS 24.229 [4].

2. INVITE request (P-CSCF-vA1 to IBCF-vA1) - see example in table 5.4.2-2.

When the P-CSCF-vA1 receives the initial INVITE request, the P-CSCF-vA1:

- adds the Feature-Caps header field with the "g.3gpp.trf" header field parameter with the address to the TRF; and
- verifies that the resulting list of Route header fields matches the list of URIs received in the Service-Route header field (during the last successful registration or re-registration). This verification is done on a per URI basis, not as a whole string.

The P-CSCF-vA1 selects an IBCF (IBCF-vA1) to be the exit IBCF towards the home IMS network hA and sends the INVITE request according to 3GPP TS 24.229 [4] to IBCF-vA1.

NOTE 1: It is implementation dependent as to how the P-CSCF obtains the address of the IBCF exit point.

Table 5.4.2-2: INVITE request (P-CSCF-vA1 to IBCF-vA1)

```

INVITE tel:+4687197378 SIP/2.0

To:
From:
P-Asserted-Identity: <sip:userA_public1@home-A.net>

```

```

P-Preferred-Service:
Contact:
CSeq:
Supported:
Route: <sip:ibcf-vA1.visited-A.net;lr>,<sip:home-abc@scscf-hA1.home-A.net;lr;iotl=visitedA-homeA>
Record-Route: <sip:pcscf-vA1.visited-A.net;lr>
Feature-Caps:*;+g.3gpp.trf="<sip:trf-vA1.visited-A.net;lr;iotl=homeA-visitedA>"
P-Access-Network-Info: 3GPP-E-UTRAN-TDD;utran-cell-id-3gpp=234151D0FCE11,
    3GPP-E-UTRAN-TDD; utran-cell-id-3gpp=234151D0FCE11;
    network-provided;local-time-zone="UTC+01:00";daylight-saving-time="01"
P-Charging-Vector: icid-value="AyretyU0dm+602IrT5tAFrbHLso=023551024";orig-ioi="Type lvisited-a"

Via: SIP/2.0/UDP pcscf-vA1.visited-A.net:5060;branch=z9hG4bKnas56565
Via: SIP/2.0/UDP [5555::aaa:bbb:ccc:ddd];branch=z9hG4bKnashds7

Content-Type:
Content-Length: (...)

c=
m=
a=
a=
a=
a=

Other SIP header fields and SDP according to 3GPP TS 24.229 [4].

```

P-Asserted-Identity: The value is set to the default public user identity i.e. userA_public1@home-A.net.

P-Charging-Vector: The P-CSCF-vA1 adds the P-Charging-Vector header field containing a new ICID value in the "icid" header field parameter and an "orig-ioi" header field parameter. The IOI value is of type 1 and identifies the visited network vA (i.e. visited-a).

P-Access-Network-Info: The P-CSCF-vA1 adds a network provided location and daylight saving information. If the received P-Access-Network-Info header field doesn't indicate that it is a network provided location, the P-Access-Network-Info header field containing the location provided by the UE-A is kept in the INVITE request.

Route: The P-CSCF-vA1 verifies that the received route set corresponds to the route set received in the Service-Route header field and adds a Route header field identifying the selected IBCF-vA1.

Record-Route: The P-CSCF-vA1 adds a Record-Route header field.

Via: The P-CSCF-vA1 adds a Via header field.

Feature-Caps: The P-CSCF-vA1 adds a g.3gpp.trf feature-capability indicator in the Feature-Caps header field. The feature-capability indicator contains the address to a TRF in the visited network and traffic leg information in an "iotl" SIP URI parameter according to IETF RFC 7549 [26]. This address is needed if the call will result in a loopback to the visited network.

3. INVITE request (IBCF-vA1 to IC-A1) - see example in table 5.4.2-3.

When the IBCF-vA1 receives the initial INVITE request containing the "+g.3gpp.trf" header field parameter in a Feature-Caps header field, the IBCF-vA1 updates the SDP as described within 3GPP TS 29.079 [5].

The IBCF-vA1 selects to route the INVITE request via an IC network A and sends the INVITE request according to 3GPP TS 24.229 [4] to the IC-A1. The IBCF-vA1 determines the next hop IP address from the URI in the first entry of the Route header field either by configured information or using a DNS query according to IETF RFC 3263 [13]. If the subsequent interconnection network is SIP-aware, the determined IP address will belong to the SIP proxy IC-A1. Otherwise the determined IP address will point to IBCF-hA1 and step 4 is skipped (not reflected in message details below).

NOTE 2: If the IBCF processes a request without a pre-defined route (e.g. the subscription to "reg" event package originated by the P-CSCF), the next-hop address can be either obtained as specified in IETF RFC 3263 [13] or be provisioned in the IBCF.

Table 5.4.2-3: INVITE request (IBCF-vA1 to IC-A1)

```

INVITE tel:+4687197378 SIP/2.0

To:
From:
P-Asserted-Identity:
P-Preferred-Service:
Contact:
CSeq:
Supported:
Route: <sip:ic-A1.interconnection-A.net;lr>,<sip:home-abc@scscf-hA1.home-A.net;lr;iotl=visitedA-homeA>
Record-Route: <sip:ibcf-vA1.visited-A.net;lr>,<sip:pcscf-vA1.visited-A.net;lr>
Feature-Caps:
P-Access-Network-Info:
P-Charging-Vector:

Via: SIP/2.0/UDP ibcf-vA1.visited-A.net;branch=z9hG4bK351g45.1
Via: SIP/2.0/UDP pcscf-vA1.visited-A.net:5060;branch=z9hG4bKnas56565
Via: SIP/2.0/UDP [5555::aaa:bbb:ccc:ddd];branch=z9hG4bKnashds7

Content-Type:
Content-Length: (...)

c=IN IP6 [5555::aaa:bbb:ccc:ddl]
m=audio 16002 RTP/AVP 97 98
a=
a=
a=
a=
a=visited-realm:1 visited-A1.net IN IP6 [5555::aaa:bbb:ccc:ddd] 16000
a=visited-realm:2 x.net IN IP6 [5555::aaa:bbb:ccc:ddl] 16002

Other SIP header fields and SDP according to 3GPP TS 24.229 [4] and 3GPP TS 29.079 [5].

```

Route: The IBCF-vA1 adds a Route header field identifying the selected node in the IC network A.

Record-Route: Based on topology hiding functionality the IBCF-vA1 will either forward the Record-Route header field with:

- one visible IBCF-vA1 entry and the P-CSCF-vA1 entry as one hidden entry; or
- an IBCF-vA1 entry and the P-CSCF-vA1 entry as visible entries.

Via: Based on topology hiding functionality the IBCF-vA1 will either forward the Via header field with:

- one visible IBCF-vA1 Via header field and the P-CSCF-vA1 Via header field as a hidden Via header field; or
- an IBCF-vA1 Via header field and the P-CSCF-vA1 Via header field as visible entries.

SDP: As the first OMR capable node, the IBCF-vA1 add the "a=visited-realm:1 visited-A1.net IN IP6 [5555::aaa:bbb:ccc:ddd] 16000" representing the realm instance of the UE-A. A second realm instance "a=visited-realm:2 x.net IN IP6 [5555::aaa:bbb:ccc:ddl] 16002" is added representing the external realm of the IBCF-vA1. The c-line and the m-line are updated to reflect the resources reserved in the TrGW of IBCF-vA1.

4. INVITE request (IC-A1 to IBCF-hA1) - see example in table 5.4.2-4.

NOTE 3: If the interconnection network is SIP-unaware, step 4 is skipped (not reflected in message details below).

When the IC-A1 receives the initial INVITE request and since the IC-A1 according to local policy allows itself to be bypassed by media then the IC-A1 updates the SDP as described within 3GPP TS 29.079 [5].

The IC-A1 selects an entry IBCF-hA1 of the home IMS network hA and sends the INVITE request according to 3GPP TS 24.229 [4] to the IBCF-hA1.

The IC-A1 may add a Route header field entry pointing to the entry point of home network hA. This is shown in example in table 5.4.2-4.

Table 5.4.2-4: INVITE request (IC-A1 to IBCF-hA1)

```

INVITE tel:+4687197378 SIP/2.0

To:
From:
P-Asserted-Identity:
P-Preferred-Service:
Contact:
CSeq:
Supported:
Route: <sip:ibcf-hA1.home-A.net;lr>,<sip:home-abc@scscf-hA1.home-A.net;lr;iotl=visitedA-homeA>
Record-Route: <sip:ic-A1.interconnection-A.net;lr>,<sip:ibcf-vA1.visited-A.net;lr>,<sip:pcscf-vA1.visited-A.net;lr>
Feature-Caps:
P-Access-Network-Info:
P-Charging-Vector: icid-value="AyretyU0dm+602IrT5tAFrbHLso=023551024";orig-ioi="Type lvisited-a";transit-ioi="ICa.1"

Via: SIP/2.0/UDP ic-A1.interconnection-A.net;branch=z9hG4bK351g45.2
Via: SIP/2.0/UDP ibcf-vA1.visited-A.net;branch=z9hG4bK351g45.1
Via: SIP/2.0/UDP pcscf-vA1.visited-A.net:5060;branch=z9hG4bKnas56565
Via: SIP/2.0/UDP [5555::aaa:bbb:ccc:ddd];branch=z9hG4bKnashds7

Content-Type:
Content-Length: (...)

c=IN IP6 [5555::aaa:bbb:ccc:dd2]
m=audio 16004 RTP/AVP 97 98
a=
a=
a=
a=
a=visited-realm:1 visited-A1.net IN IP6 [5555::aaa:bbb:ccc:ddd] 16000
a=visited-realm:2 x.net IN IP6 [5555::aaa:bbb:ccc:dd1] 16002
a=visited-realm:3 x.net IN IP6 [5555::aaa:bbb:ccc:dd2] 16004

Other SIP header fields and SDP according to 3GPP TS 24.229 [4] and 3GPP TS 29.079 [5].

```

P-Charging-Vector: The IC-A1 adds the "transit-ioi" header field parameter identifying the interconnection network (i.e. ICa.1).

Route: The IC-A1 adds a Route header field identifying the selected entry point in the home network hA.

Record-Route: Based on interconnection operator SLA the IC-A1 adds an entry to the Record-Route header field or not.

Via: The IC-A1 adds a Via header field.

SDP: A third realm instance "a=visited-realm:3 x.net IN IP6 [5555::aaa:bbb:ccc:dd2] 16004" is added representing the realm of the IC-A1. The c-line and the m-line are updated to reflect the resources reserved in the IC-A1.

5. INVITE request (IBCF-hA1 to S-CSCF-hA1) - see example in table 5.4.2-5.

When the IBCF-hA1 receives the initial INVITE request containing the "+g.3gpp.trf" header field parameter in a Feature-Caps header field, the IBCF-hA1 updates the SDP as described within 3GPP TS 29.079 [5].

In this example, the IBCF-hA1 does not add any "transit-ioi" header field parameter in the P-Charging-Vector header field. However, the IBCF-hA1 adds the "transit-ioi" header field parameter based on local policy, when the "transit-ioi" identifying the preceding interconnection network is not included in the received request (e.g. when the preceding interconnection network is not an IMS transit network).

The IBCF-hA1 sends the INVITE request according to 3GPP TS 24.229 [4] to the S-CSCF-hA1.

Table 5.4.2-5: INVITE request (IBCF-hA1 to S-CSCF-hA1)

```

INVITE tel:+4687197378 SIP/2.0

To:
From:
P-Asserted-Identity:

```

```

P-Preferred-Service:
Contact:
CSeq:
Supported:
Route: <sip:home-abc@scscf-hA1.home-A.net;lr;iotl=visitedA-homeA>
Record-Route: <sip:ibcf-hA1.home-A.net:5070;lr>,<sip:ic-A1.interconnection-A.net;lr>,<sip:ibcf-vA1.visited-A.net;lr>,<sip:pcscf-vA1.visited-A.net;lr>
Feature-Caps:
P-Access-Network-Info:
P-Charging-Vector:

Via: SIP/2.0/UDP ibcf-hA1.home-A.net;branch=z9hG4bK351g45.3
Via: SIP/2.0/UDP ic-A1.interconnection-A.net;branch=z9hG4bK351g45.2
Via: SIP/2.0/UDP ibcf-vA1.visited-A.net;branch=z9hG4bK351g45.1
Via: SIP/2.0/UDP pcscf-vA1.visited-A.net:5060;branch=z9hG4bKnas56565
Via: SIP/2.0/UDP [5555::aaa:bbb:ccc:ddd];branch=z9hG4bKnashds7

Content-Type:
Content-Length: (...)

c=IN IP6 [5555::aaa:bbb:ccc:dd3]
m=audio 16006 RTP/AVP 97 98
a=
a=
a=
a=
a=visited-realm:1 visited-A.net IN IP6 [5555::aaa:bbb:ccc:ddd] 16000
a=visited-realm:2 x.net IN IP6 [5555::aaa:bbb:ccc:dd1] 16002
a=visited-realm:4 home-A.net IN IP6 [5555::aaa:bbb:ccc:dd3] 16006

Other SIP header fields and SDP according to 3GPP TS 24.229 [4] and 3GPP TS 29.079 [5].

```

Via: The IBCF-hA1 adds a Via header field.

Record-Route: The IBCF-hA1 adds a Record-Route header field.

SDP: IBCF-hA1 detects, by inspecting the received set of OMR visited-realm attributes, that the resources in IC-A1 can be bypassed. Since the realm of the outgoing side is different than the realm of the incoming side, the IBCF-hA1 adds the realm instance 4 representing the internal realm of the IBCF-hA1 and updates the c-line and the m-line to reflect the resources reserved in the TrGW of the IBCF-hA1.

6. INVITE request (S-CSCF-hA1 to AS-hA1) - see example in table 5.3.2-6.

The S-CSCF-hA1 applies the same procedure as in step 6 in clause 5.3.2. The OMR specific attributes are kept in the SDP as received from the IBCF-hA1.

7. INVITE request (AS-hA1 to S-CSCF-hA1) - see example in table 5.4.2-7.

AS-hA1 applies the service of the originating user and removes the first Route header field entry.

The AS-hA1 removes the "orig-ioi" header field parameter from the INVITE request and inserts a type 3 "orig-ioi" header field parameter set to a value that identifies the service provider from which the request is sent. In this case the IOI value is the same as the home network operator identity.

The specifics of the service does not require access to a media and the "+g.3gpp.home-visited" Feature-Caps header field parameter is kept in the INVITE request. This is an indication to the S-CSCF-hA1 that a loopback is a viable option.

All other SIP headers are set due to procedures described within 3GPP TS 24.229 [4].

Editor's note: The behaviour of the transit-ioi value is currently discussed and needs further consideration how the S-CSCF to AS correlation is describes.

Table 5.4.2-7: INVITE request (AS-hA1 to S-CSCF-hA1)

```

INVITE tel:+4687197378 SIP/2.0

To:
From:
P-Asserted-Identity:
P-Asserted-Service:

```

```

Contact:
CSeq:
Supported:
Route: <sip:orig@scscf-hA1.home-A.net;lr>
Record-Route: <sip:as-hA1.home-A.net:5070;lr>, <sip:scscf-hA1.home-A.net:5070;lr>,
<sip:ibcf-hA1.home-A.net:5070;lr>, <sip:ic-A1.interconnection-A.net;lr>,
<sip:ibcf-vA1.visited-A.net;lr>, <sip:pcscf-vA1.visited-A.net;lr>
Feature-Caps: *;+g.3gpp.home-visited="<visited-A>" ;+g.3gpp.trf="<sip:trf-vA1.visited-
A.net;iotl=homeA-visitedA>"
P-Access-Network-Info:
P-Charging-Vector: icid-value="AyretyU0dm+602IrT5tAFrbHLso=023551024";orig-ioi="Type 3home-a"

Via: SIP/2.0/UDP as-hA1.home-A.net;branch=z9hG4bK351g45.5
Via: SIP/2.0/UDP scscf-hA1.home-A.net;branch=z9hG4bK351g45.4
Via: SIP/2.0/UDP ibcf-hA1.home-A.net;branch=z9hG4bK351g45.3
Via: SIP/2.0/UDP ic-A1.interconnection-A.net;branch=z9hG4bK351g45.2
Via: SIP/2.0/UDP ibcf-vA1.visited-A.net;branch=z9hG4bK351g45.1
Via: SIP/2.0/UDP pcscf-vA1.visited-A.net:5060;branch=z9hG4bK351g45.1
Via: SIP/2.0/UDP [5555::aaa:bbb:ccc:ddd];branch=z9hG4bKnashds7

Content-Type:
Content-Length: (...)

c=
m=
a=
a=
a=
a=
a=
a=
a=

Other SIP header fields and SDP according to 3GPP TS 24.229 [4] and 3GPP TS 29.079 [5].

```

P-Charging-Vector: The AS-hA1 replaces the "orig-ioi" header field parameter. The AS-hA1 sets the type 3 "orig-ioi" header field parameter to a value that identifies the sending network. In the example the AS-hA1 belongs to the same network as the S-CSCF-hA1 and thus the value is the same as the IOI value received from S-CSCF-hA1, i.e. "home-a". If the AS is provided by a 3rd Party Service Provider, the value will be different than the value received from S-CSCF-hA1. If more than one AS is within the path the "orig-ioi" header field parameter values could be changed based on the relation between S-CSCF-hA1 and the related AS.

Record-Route: The entries to this header field need to be added based on the related dip's to the AS. The AS could behave as B2BUA. In such case the AS could store the entries and setup a new Record-Route header field with the AS as the only entry.

Via: The AS-hA1 adds a Via header field.

Editor's note: The behaviour of the transit-ioi value is currently discussed and needs further consideration how the S-CSCF to AS correlation is describes.

8. INVITE request (S-CSCF-hA1 to IBCF-hA1) - see example in table 5.4.2-8.

When the S-CSCF-hA1 receives the initial INVITE request and the "g.3gpp.home-visited" Feature-Caps header field parameter is still in the request, the S-CSCF-hA1 decides according to local policy that loopback routing will be used.

The S-CSCF-hA1 includes:

- the TRF URI included in the "+g.3gpp.trf" Feature-Caps header field parameter in the Route header field;
- a Feature-Caps header field with the "+g.3gpp.loopback" header field parameter to indicate that loopback routing is ongoing. The "+g.3gpp.loopback" header field parameter can optionally contain the name of the home network; and
- the "orig-ioi" header field parameter within the P-Charging-Vector header field will be replaced by a type 1 IOI which reflects the home network of user A (i.e. "home-a"). Any "transit-ioi" header field parameter for the path P-CSCF-vA1 to S-CSCF-hA1 will not be maintained after this point.

The S-CSCF-hA1 removes the "+g.3gpp.home-visited" and "+g.3gpp.trf" Feature-Caps header field parameters.

NOTE 4: Number normalization and ENUM translation is deferred to the visited network according to local policy.

The INVITE request is sent according to 3GPP TS 24.229 [4] to the IBCF-hA1.

Table 5.4.2-8: INVITE request (S-CSCF-hA1 to IBCF-hA1)

<pre> INVITE tel:+4687197378 SIP/2.0 To: From: P-Asserted-Identity: P-Asserted-Service: Contact: CSeq: Supported: Route: <sip:ibcf-hA1.home-A.net;lr>,<sip:trf-vA1.visited-A.net;lr;iotl=homeA-visitedA> Record-Route: <sip:scscf-hA1.home-A.net:5070;lr>,<sip:as-hA1.home-A.net:5070;lr>,< <sip:scscf-hA1.home-A.net:5070;lr>,<sip:ibcf-hA1.home-A.net:5070;lr>,< <sip:ic-A1.interconnection-A.net;lr>,<sip:ibcf-vA1.visited-A.net;lr>,< <sip:pcscf-vA1.visited-A.net;lr> Feature-Caps: *;+g.3gpp.loopback="<homenetwork_A>" P-Access-Network-Info: P-Charging-Vector: icid-value="AyretyU0dm+602IrT5tAFrbHLso=023551024";orig-ioi="Type 1home-a" Via: SIP/2.0/UDP scscf-hA1.home-A.net;branch=z9hG4bK351g45.6 Via: SIP/2.0/UDP as-hA1.home-A.net;branch=z9hG4bK351g45.5 Via: SIP/2.0/UDP scscf-hA1.home-A.net;branch=z9hG4bK351g45.4 Via: SIP/2.0/UDP ibcf-hA1.home-A.net;branch=z9hG4bK351g45.3 Via: SIP/2.0/UDP ic-A1.interconnection-A.net;branch=z9hG4bK351g45.2 Via: SIP/2.0/UDP ibcf-vA1.visited-A.net;branch=z9hG4bK351g45.1 Via: SIP/2.0/UDP pcscf-vA1.visited-A.net:5060;branch=z9hG4bK351g45.1 Via: SIP/2.0/UDP [5555::aaa:bbb:ccc:ddd];branch=z9hG4bK351g45.7 Content-Type: Content-Length: (...) c= m= a= a= a= a= a= a= a= Other SIP header fields and SDP according to 3GPP TS 24.229 [4] and 3GPP TS 29.079 [5]. </pre>
--

- Route:** The S-CSCF-hA1 adds the Route header field received in the "+g.3gpp.trf" header field parameter as the bottom most Route header field (including traffic leg information in the received "iotl" SIP URI parameter). The Route header field with the address of the selected IBCF-hA2 is added at the top.
- Via:** The S-CSCF-hA1 adds a Via header field.
- Record-Route:** The S-CSCF-hA1 adds a Record-Route header field.
- Feature-Caps:** The S-CSCF-hA1 adds a Feature-Caps header field with the "+g.3gpp.loopback" header field parameter set to the identifier of the home network to indicate that loopback routing is ongoing.
- P-Charging-Vector:** The S-CSCF-hA1 replaces the type 3 IOI value received in the "orig-ioi" header field parameter from the AS-hA1 with a type 1 "orig-ioi" header field parameter identifying the sending network (i.e. home network hA). Thus the "orig-ioi" header field parameter value is now different compared with the received INVITE at the IBCF-hA1 from the visited network.

9. INVITE request (IBCF-hA1 to IC-A1) - see example in table 5.4.2-9.

When the IBCF-hA1 receives the initial INVITE request containing the "+g.3gpp.loopback" header field parameter in a Feature-Caps header field, the IBCF-hA1 updates the SDP as defined within 3GPP TS 29.079 [5].

The IBCF-hA1 selects to route the INVITE request via an IC network A and sends the INVITE request according to 3GPP TS 24.229 [4] to the IC-A1. From theory it could be also another IC network but that is due to SLA and operator policy. The IBCF-vA1 determines the next hop IP address from the URI in the first entry of the Route header field either by configured information or using a DNS query according to IETF RFC 3263 [13]. If the subsequent interconnection network is SIP-aware, the determined IP address will belong to the SIP proxy IC-A1. Otherwise the determined IP address will point to IBCF-vA1 and step 10 is skipped (not reflected in message details below).

Table 5.4.2-9: INVITE request (IBCF-hA1 to IC-A1)

<pre> INVITE tel:+4687197378 SIP/2.0 To: From: P-Asserted-Identity: P-Asserted-Service: Contact: CSeq: Supported: Route: <sip:ic-A1.interconnection-A.net;lr>,<sip:trf-vA1.visited-A.net;lr;iotl=homeA-visitedA> Record-Route: <sip:ibcf-hA1.home-A.net:5070;lr>,<sip:scscf-hA1.home-A.net:5070;lr>,<sip:as-hA1.home-A.net:5070;lr>,<sip:scscf-hA1.home-A.net:5070;lr>,<sip:ibcf-hA1.home-A.net:5070;lr>,<sip:ic-A1.interconnection-A.net;lr>,<sip:ibcf-vA1.visited-A.net;lr>,<sip:pcscf-vA1.visited-A.net;lr> Feature-Caps: P-Access-Network-Info: P-Charging-Vector: Via: SIP/2.0/UDP ibcf-hA1.home-A.net;branch=z9hG4bK351g45.7 Via: SIP/2.0/UDP scscf-hA1.home-A.net;branch=z9hG4bK351g45.6 Via: SIP/2.0/UDP as-hA1.home-A.net;branch=z9hG4bK351g45.5 Via: SIP/2.0/UDP scscf-hA1.home-A.net;branch=z9hG4bK351g45.4 Via: SIP/2.0/UDP ibcf-hA1.home-A.net;branch=z9hG4bK351g45.3 Via: SIP/2.0/UDP ic-A1.interconnection-A.net;branch=z9hG4bK351g45.2 Via: SIP/2.0/UDP ibcf-vA1.visited-A.net;branch=z9hG4bK351g45.1 Via: SIP/2.0/UDP pcscf-vA1.visited-A.net:5060;branch=z9hG4bKnas56565 Via: SIP/2.0/UDP [5555::aaa:bbb:ccc:ddd];branch=z9hG4bKnashds7 Content-Type: Content-Length: (...) c=IN IP6 [5555::aaa:bbb:ccc:ddl] m=audio 16002 RTP/AVP 97 98 a= a= a= a= a=visited-realm:1 visited-A1.net IN IP6 [5555::aaa:bbb:ccc:ddd] 16000 a=visited-realm:2 x.net IN IP6 [5555::aaa:bbb:ccc:ddl 16002] Other SIP header fields and SDP according to 3GPP TS 24.229 [4] and 3GPP TS 29.079 [5]. </pre>

Route: The IBCF-hA1 adds a Route header field with the address of the selected node in the IC network A.

Record-Route: The entries to this header field need to be added based on operator policy. The example shows the possible Record-Route header field when no restriction according to the operator policy applies. Based on topology hiding functionality the IBCF-hA1 will either forward the Record-Route header field with:

- one visible IBCF-hA1 entry and the remaining collected entries as one hidden entry; or
- an IBCF-hA1 entry and whole content of already collected entries as visible entries.

Via: Based on topology hiding functionality the IBCF-hA1 will either forward the Via header field with:

- one visible IBCF-hA1 Via header field and the remaining collected set of Via header fields as one hidden Via header field; or
- an IBCF-hA1 Via header field and the whole set of already collected Via header fields as visible entries.

SDP: IBCF-hA1 detects, by inspecting the received set of OMR visited-realm attributes, that the resources in realm instance 4 (i.e. the IBCF-hA1 acting as an entry IBCF in the home network) can be bypassed and removes the "a=visited-realm:4 home-A.net IN IP6 [5555::aaa:bbb:ccc:dd3]" from the outgoing SDP offer. The c-line and the m-line are updated to be the IP address and port of the IBCF-vA1.

10. INVITE request (IC-A1 to IBCF-vA1) - see example in table 5.4.2-10.

NOTE 5: If the interconnection network is SIP-unaware, step 10 is skipped.

When the IC-A1 receives the initial INVITE request the IC-A1 detects that an optimal media path avoiding media to be sent through the home IMS network hA is possible. The IC-A1 updates the SDP according to 3GPP TS 29.079 [5].

The IC-A1 selects an entry IBCF in the visited network and sends the INVITE request according to 3GPP TS 24.229 [4] to the IBCF-vA1. Seen from principle point of view the IBCF could be any entry point (IBCF-vAx) of the visited network.

The content of the Record-Route header field and the Via header field will be based on local policy and updated accordingly.

IC-A1 detects that the IP address in the SDP offer is within the same realm as the on the outgoing side of IC-A1 and determines that the IC-A1 can be bypassed by media and uses the incoming SDP offer as the outgoing SDP offer.

Table 5.4.2-10: INVITE request (IC-A1 to IBCF-vA1)

```
INVITE tel:+4687197378 SIP/2.0

To:
From:
P-Asserted-Identity:
P-Asserted-Service:
Contact:
CSeq:
Supported:
Route: <sip:ibcf-vA1.visited-A.net;lr>,<sip:trf-vA1.visited-A.net;lr;iotl=homeA-visitedA>
Record-Route: <sip:ic-A1.interconnection-A.net;lr>
<sip:ibcf-hA1.home-A.net:5070;lr>,<sip:scscf-hA1.home-A.net:5070;lr>,<sip:as-hA1.home-A.net:5070;lr>,<sip:scscf-hA1.home-A.net:5070;lr>,<sip:ibcf-hA1.home-A.net:5070;lr>,<sip:ic-A1.interconnection-A.net;lr>,<sip:ibcf-vA1.visited-A.net;lr>,<sip:pcscf-vA1.visited-A.net;lr>
Feature-Caps:
P-Access-Network-Info:
P-Charging-Vector:icid-value="AyretyU0dm+6O2Irt5tAFrbHLso=023551024";orig-ioi="Type lhome-a";transit-ioi="ICT.1"

Via: SIP/2.0/UDP ic-A1.interconnection-A.net;branch=z9hG4bK351g45.8
Via: SIP/2.0/UDP ibcf-hA1.home-A.net;branch=z9hG4bK351g45.7
Via: SIP/2.0/UDP scscf-hA1.home-A.net;branch=z9hG4bK351g45.6
Via: SIP/2.0/UDP as-hA1.home-A.net;branch=z9hG4bK351g45.5
Via: SIP/2.0/UDP scscf-hA1.home-A.net;branch=z9hG4bK351g45.4
Via: SIP/2.0/UDP ibcf-hA1.home-A.net;branch=z9hG4bK351g45.3
Via: SIP/2.0/UDP ic-A1.interconnection-A.net;branch=z9hG4bK351g45.2
Via: SIP/2.0/UDP ibcf-vA1.visited-A.net;branch=z9hG4bK351g45.1
Via: SIP/2.0/UDP pcscf-vA1.visited-A.net:5060;branch=z9hG4bKnas56565
Via: SIP/2.0/UDP [5555::aaa:bbb:ccc:ddd];branch=z9hG4bKnashds7

Content-Type:
Content-Length: (...)

c=
m=
a=
a=
a=
a=
a=
a=

Other SIP header fields and SDP according to 3GPP TS 24.229 [4] and 3GPP TS 29.079 [5].
```

Via: The IC-A1 adds a Via header field.

Route: The IC-A1 adds a Route header field with the address of the selected node in the visited network A.

Record-Route: The IC-A1 adds a Record-Route header field.

P-Charging-Vector: The IC-A1 adds the "transit-ioi" header field with a value identifying the interconnection network A (i.e. "ICt.1").

11. INVITE request (IBCF-vA1 to TRF-vA1) - see example in table 5.4.2-11.

When the IBCF-vA1 receives the initial INVITE request containing the "+g.3gpp.loopback" header field parameter in a Feature-Caps header field, the IBCF-vA1 searches for a possible optimal media path and detects that an optimal media path within the visited network is possible. The IBCF-vA1 updates the SDP according to 3GPP TS 29.079 [5].

The IBCF-vA1 sends the INVITE request according to 3GPP TS 24.229 [4] to the TRF-vA1.

The content of the Record-Route header field and the Via header field will be based on local policy and updated accordingly.

In this example, the IBCF-hA1 does not add any "transit-ioi" header field parameter in the P-Charging-Vector header field. However, the IBCF-hA1 adds the "transit-ioi" header field parameter based on local policy, when the "transit-ioi" identifying the preceding interconnection network is not included in the received request (e.g. when the preceding interconnection network is not an IMS transit network).

Table 5.4.2-11: INVITE request (IBCF-vA1 to TRF vA1)

```

INVITE tel:+4687197378 SIP/2.0

To:
From:
P-Asserted-Identity:
P-Asserted-Service:
Contact:
CSeq:
Supported:
Route: <sip:trf-vA1.visited-A.net;lr;iotl=homeA-visitedA>
Record-Route: <sip:ibcf-vA1.visited-A.net;lr>
<sip:ic-A1.interconnection-A.net;lr>
<sip:ibcf-hA1.home-A.net:5070;lr>, <sip:scscf-hA1.home-A.net:5070;lr>,
<sip:as-hA1.home-A.net:5070;lr>, <sip:scscf-hA1.home-A.net:5070;lr>,
<sip:ibcf-hA1.home-A.net:5070;lr>, <sip:ic-A1.interconnection-A.net;lr>,
<sip:ibcf-vA1.visited-A.net;lr>, <sip:pcscf-vA1.visited-A.net;lr>
Feature-Caps:
P-Access-Network-Info:
P-Charging-Vector:

Via: SIP/2.0/UDP ibcf-vA1.visited-A.net;branch=z9hG4bK351g45.9
Via: SIP/2.0/UDP ic-A1.interconnection-A.net;branch=z9hG4bK351g45.8
Via: SIP/2.0/UDP ibcf-hA1.home-A.net;branch=z9hG4bK351g45.7
Via: SIP/2.0/UDP scscf-hA1.home-A.net;branch=z9hG4bK351g45.6
Via: SIP/2.0/UDP as-hA1.home-A.net;branch=z9hG4bK351g45.5
Via: SIP/2.0/UDP scscf-hA1.home-A.net;branch=z9hG4bK351g45.4
Via: SIP/2.0/UDP ibcf-hA1.home-A.net;branch=z9hG4bK351g45.3
Via: SIP/2.0/UDP ic-A1.interconnection-A.net;branch=z9hG4bK351g45.2
Via: SIP/2.0/UDP ibcf-vA1.visited-A.net;branch=z9hG4bK351g45.1
Via: SIP/2.0/UDP pcscf-vA1.visited-A.net:5060;branch=z9hG4bKnas56565
Via: SIP/2.0/UDP [5555::aaa:bbb:ccc:ddd];branch=z9hG4bKnashds7

Content-Type:
Content-Length: (...)

c=IN IP6 5555::aaa:bbb:ccc:ddd
m=audio 16000 RTP/AVP 97 98
a=
a=
a=
a=
a=visited-realm:1 visited-A1.net IN IP6 5555::aaa:bbb:ccc:dd1 16000

```

Other SIP header fields and SDP according to 3GPP TS 24.229 [4] and 3GPP TS 29.079 [5].

Via: The IBCF-vA1 adds a Via header field.

Record-Route: The IBCF-vA1 adds a Record-Route header field.

SDP: IBCF-vA1 detects that the realm in the "a=visited-realm:1 visited-A1.net IN IP6 [5555::aaa:bbb:ccc:ddd] 1600" in the incoming SDP offer is the same realm as on the outgoing side of IBCF-vA1 and determines that the IBCF-vA1 "a=visited-realm:2 x.net IN IP6 [5555::aaa:bbb:ccc:dd1] 16002" can be bypassed. The c-line and the m-line are updated to be the IP address and port of the UE-A.

12. INVITE request (TRF-vA1 to IBCF-vA1).

When the TRF-vA1 receives the initial INVITE request the TRF-vA1:

- performs number normalization (if used by local policy) and ENUM translation and possibly updates the request-URI if necessary;
- replaces an type 1 "orig-ioi" header field parameter value in the P-Charging-Vector header field with a type 2 "orig-ioi" header field parameter value where the IOI value identifies the visited network;
- possibly adds an additional Route header field pointing to the IBCF-vA1 and also to the IC in cases where the IBCF-vA1 has no routing decision to do;
- removes the "+g.3gpp.loopback" header field parameter from the Feature-Caps header field of the outgoing request; and
- appends the "iotl" SIP URI parameter with the value "visitedA-homeB" to the Request-URI.

The TRF-vA1 selects an IBCF to act as an exit point and sends the INVITE request according to 3GPP TS 24.229 [4] to the IBCF-vA1 (which could be also another IBCF e.g. IBCF-vA2).

The content of the Record-Route header field and the Via header field will be based on local policy and updated accordingly.

The OMR specific attributes in the SDP are kept as received from the IBCF-vA1.

13. INVITE request (IBCF-vA1 to IC-T1) - see example in table 5.4.2-13.

When the IBCF-vA1 receives the initial INVITE request the IBCF-vA1 selects the IC-T1 if not already a Route header field exists pointing to the IC-T1. The IBCF-vA1 determines the next hop IP address from the Request-URI either by configured information or using a DNS query according to IETF RFC 3263 [13]. If the subsequent interconnection network is SIP-aware, the determined IP address will belong to the SIP proxy IC-T1. Otherwise the determined IP address will point to an IBCF acting as an entry point in the remote home network (not reflected in message details below).

Record-Route header field and Via header field will be based on local policy and updated accordingly. The example in table 5.4.2-13 shows one example of the content of the header fields and the text below the table explains other possibilities.

The IBCF-vA1 removes all OMR specific attributes from the SDP offer.

Table 5.4.2-13: INVITE request (IBCF-vA1 to IC-T1)

<pre>INVITE sip:+4687197378@home-R.net;user=phone;iotl=visitedA-homeB SIP/2.0 To: From: P-Asserted-Identity: P-Asserted-Service: Contact: CSeq: Supported: Route: <sip:ic-T1.interconnection-T.net;lr> Record-Route: <sip:ibcf-vA1.visited-A.net:5070;lr>, <sip:trf-vA1.visited-A.net:5070;lr>, <sip:ibcf-vA1.visited-A.net:5070;lr>, <sip:ic-A1.interconnection-A.net;lr>, <sip:ibcf-hA1.home-A.net:5070;lr>, <sip:scscf-hA1.home-A.net:5070;lr>, <sip:as-hA1.home-A.net:5070;lr>, <sip:scscf-hA1.home-A.net:5070;lr></pre>

```

<sip:ibcf-hA1.home-A.net:5070;lr>,<sip:ic-A1.interconnection-A.net;lr>,
<sip:ibcf-vA1.visited-A.net;lr>,<sip:pcscf-vA1.visited-A.net;lr>
P-Access-Network-Info:
P-Charging-Vector: icid-value="AyretyU0dm+602IrT5tAFrbHLso=023551024";orig-ioi="visited-a"

Via: SIP/2.0/UDP ibcf-vA1.visited-A.net;branch=z9hG4bK351g45.11
Via: SIP/2.0/UDP trf-vA1.visited-A.net;branch=z9hG4bK351g45.10
Via: SIP/2.0/UDP ibcf-vA1.visited-A.net;branch=z9hG4bK351g45.9
Via: SIP/2.0/UDP ic-A1.interconnection-A.net;branch=z9hG4bK351g45.8
Via: SIP/2.0/UDP ibcf-hA1.home-A.net;branch=z9hG4bK351g45.7
Via: SIP/2.0/UDP scscf-hA1.home-A.net;branch=z9hG4bK351g45.6
Via: SIP/2.0/UDP as-hA1.home-A.net;branch=z9hG4bK351g45.5
Via: SIP/2.0/UDP scscf-hA1.home-A.net;branch=z9hG4bK351g45.4
Via: SIP/2.0/UDP ibcf-hA1.home-A.net;branch=z9hG4bK351g45.3
Via: SIP/2.0/UDP ic-A1.interconnection-A.net;branch=z9hG4bK351g45.2
Via: SIP/2.0/UDP ibcf-vA1.visited-A.net;branch=z9hG4bK351g45.1
Via: SIP/2.0/UDP pcscf-vA1.visited-A.net:5060;branch=z9hG4bKnas56565
Via: SIP/2.0/UDP [5555::aaa:bbb:ccc:ddd];branch=z9hG4bKdashds7

Content-Type:
Content-Length: (...)

c=IN IP6 [5555::aaa:bbb:ccc:ddl]
m=audio 16016 RTP/AVP 97 98
a=
a=
a=
a=

Other SIP header fields and SDP according to 3GPP TS 24.229 [4] and 3GPP TS 29.079 [5].

```

Route: The IBCF-vA1 adds a Route header field with the address of the selected node in the IC network B.

Record-Route: Based on topology hiding functionality the IBCF-vA1 will either forward the Record-Route header field with:

- one visible IBCF-vA1 entry and the remaining collected entries as one hidden entry; or
- an IBCF-vA1 entry and whole content of already collected entries as visible entries.

Via: Based on topology hiding functionality the IBCF-vA1 will either forward the Via header field with:

- one visible IBCF-vA1 Via header field and the remaining collected set of Via header fields as one hidden Via header field; or
- an IBCF-vA1 Via header field and the whole set of already collected Via header fields as visible entries.

SDP: The IBCF-vA1 anchor media and insert the IBCF-vA1 IP address and port number.

14.183 (Session Progress) response (IC-T1 to IBCF-vA1) - see example in table 5.4.2-14.

NOTE 6: If the interconnection network is SIP-unaware, step 14 is executed between IBCF-hB and IBCF-vA1 instead.

IC-T1 forwards the received 183 (Session Progress) response to the IBCF-vA1 based on the Via header field.

Record-Route header field and Via header fields will be updated accordingly. The example in table 5.4.2-14 shows one example of the content of the header fields.

Table 5.4.2-14: SIP 183 (Session Progress) response (IC-T1 to IBCF-vA1)

```

SIP/2.0 183 Session Progress

To: <tel:+4687197378>;tag=654a
From: <sip:userA_public1@home-A.net>;tag=4fa3
P-Asserted-Identity: <tel:+4687197378>,<sip:+4687197378@home-R.net;user=phone>
Contact: <sip:[5555::bbb:ccc:ddd:aaa]>
CSeq: 1 INVITE
Require: 100rel, precondition
Record-Route: <One or more entries with entities of the remote network>,

```

```

<sip:ic-T1.interconnection-T.net:5070;lr>,
<sip:ibcf-vA1.visited-A.net:5070;lr>,<sip:trf-vA1.visited-A.net:5070;lr>,
<sip:ibcf-vA1.visited-A.net:5070;lr>,<sip:ic-A1.interconnection-A.net;lr>,
<sip:ibcf-hA1.home-A.net:5070;lr>,<sip:scscf-hA1.home-A.net:5070;lr>,
<sip:as-hA1.home-A.net:5070;lr>,<sip:scscf-hA1.home-A.net:5070;lr>,
<sip:ibcf-hA1.home-A.net:5070;lr>,<sip:ic-A1.interconnection-A.net;lr>,
<sip:ibcf-vA1.visited-A.net;lr>,<sip:pcscf-vA1.visited-A.net;lr>
P-Access-Network-Info:
P-Charging-Vector: icid-value="AyretyU0dm+602IrT5tAFrbHLso=023551024";orig-ioi="visited-a";term-
ioi="home-r";transit-ioi="ICT.1"

Via: SIP/2.0/UDP ibcf-vA1.visited-A.net;branch=z9hG4bK351g45.11
Via: SIP/2.0/UDP trf-vA1.visited-A.net;branch=z9hG4bK351g45.10
Via: SIP/2.0/UDP ibcf-vA1.visited-A.net;branch=z9hG4bK351g45.9
Via: SIP/2.0/UDP ic-A1.interconnection-A.net;branch=z9hG4bK351g45.8
Via: SIP/2.0/UDP ibcf-hA1.home-A.net;branch=z9hG4bK351g45.7
Via: SIP/2.0/UDP scscf-hA1.home-A.net;branch=z9hG4bK351g45.6
Via: SIP/2.0/UDP as-hA1.home-A.net;branch=z9hG4bK351g45.5
Via: SIP/2.0/UDP scscf-hA1.home-A.net;branch=z9hG4bK351g45.4
Via: SIP/2.0/UDP ibcf-hA1.home-A.net;branch=z9hG4bK351g45.3
Via: SIP/2.0/UDP ic-A1.interconnection-A.net;branch=z9hG4bK351g45.2
Via: SIP/2.0/UDP ibcf-vA1.visited-A.net;branch=z9hG4bK351g45.1
Via: SIP/2.0/UDP pcscf-vA1.visited-A.net:5060;branch=z9hG4bKnas56565
Via: SIP/2.0/UDP [5555::aaa:bbb:ccc:ddd];branch=z9hG4bKnashds7

Content-Type: application/sdp
Content-Length: (...)

c=IN IP6 [5555::aaa:bbb:ccc:dd4]
m=audio 16511 RTP/AVP 97 98
a=curr:qos local none
a=curr:qos remote none
a=des:qos mandatory local sendrecv
a=des:qos none remote sendrecv

Other SIP header fields and SDP according to 3GPP TS 24.229 [4].

```

P-Charging-Vector: The IC-T1 adds the "transit-ioi" header field parameter identifying the interconnection network (i.e. ICT.1).

Require: The Require header field contains the option-tag "100rel" indicating reliable sending of the 183 (Session Progress) response and the option-tag "precondition" indicating the usage of the precondition mechanism.

SDP MIME body The received SDP answer includes connection address information for the media line that is a valid IP address other than the unspecified address (i.e., IPv4: "0.0.0.0", IPv6: "invalid.invalid").

15. 183 (Session Progress) response (IBCF-vA1 to TRF-vA1) - see example in table 5.4.2-15.

In this example, the IBCF-vA1 does not add any "transit-ioi" header field parameter in the P-Charging-Vector header field. However, the IBCF-vA1 adds the "transit-ioi" header field parameter based on local policy, when the "transit-ioi" identifying the preceding interconnection network is not included in the received request (e.g. when the preceding interconnection network is not an IMS transit network).

Table 5.4.2-15: SIP 183 (Session Progress) response (IBCF-vA1 to TRF-vA1)

```

SIP/2.0 183 Session Progress

To:
From:
P-Asserted-Identity:
Contact:
CSeq:
Require:
Record-Route: <One or more entries with entities of the remote network>,
  <sip:ic-T1.interconnection-T.net:5070;lr>,
  <sip:ibcf-vA1.visited-A.net:5070;lr>,<sip:trf-vA1.visited-A.net:5070;lr>,
  <sip:ibcf-vA1.visited-A.net:5070;lr>,<sip:ic-A1.interconnection-A.net;lr>,
  <sip:ibcf-hA1.home-A.net:5070;lr>,<sip:scscf-hA1.home-A.net:5070;lr>,
  <sip:as-hA1.home-A.net:5070;lr>,<sip:scscf-hA1.home-A.net:5070;lr>,
  <sip:ibcf-hA1.home-A.net:5070;lr>,<sip:ic-A1.interconnection-A.net;lr>,

```

```

    <sip:ibcf-vA1.visited-A.net;lr>,<sip:pcscf-vA1.visited-A.net;lr>
P-Access-Network-Info:
P-Charging-Vector:

Via: SIP/2.0/UDP trf-vA1.visited-A.net;branch=z9hG4bK351g45.10
Via: SIP/2.0/UDP ibcf-vA1.visited-A.net;branch=z9hG4bK351g45.9
Via: SIP/2.0/UDP ic-A1.interconnection-A.net;branch=z9hG4bK351g45.8
Via: SIP/2.0/UDP ibcf-hA1.home-A.net;branch=z9hG4bK351g45.7
Via: SIP/2.0/UDP scscf-hA1.home-A.net;branch=z9hG4bK351g45.6
Via: SIP/2.0/UDP as-hA1.home-A.net;branch=z9hG4bK351g45.5
Via: SIP/2.0/UDP scscf-hA1.home-A.net;branch=z9hG4bK351g45.4
Via: SIP/2.0/UDP ibcf-hA1.home-A.net;branch=z9hG4bK351g45.3
Via: SIP/2.0/UDP ic-A1.interconnection-A.net;branch=z9hG4bK351g45.2
Via: SIP/2.0/UDP ibcf-vA1.visited-A.net;branch=z9hG4bK351g45.1
Via: SIP/2.0/UDP pcscf-vA1.visited-A.net:5060;branch=z9hG4bKnas56565
Via: SIP/2.0/UDP [5555::aaa:bbb:ccc:ddd];branch=z9hG4bKnashds7

Content-Type:
Content-Length: (...)

c=IN IP6 [5555::aaa:bbb:ccc:ddl]
t=0 0
m=audio 16511 RTP/AVP 97 98
a=
a=
a=
a=
a=visited-realm:1 visited-A1.net IN IP6 [5555::aaa:bbb:ccc:ddl] 16511

Other SIP header fields according to 3GPP TS 24.229 [4].

```

SDP MIME body: The IBCF-vA1 adds the a=visited-realm according to 3GPP TS 29.079 [5] indicating that an optimal media route has occurred and replaces the received IP address with its own IP address.

16.183 (Session Progress) response (TRF-vA1 to IBCF-vA1) - see example in table 5.4.2-16.

Table 5.4.2-16: SIP 183 (Session Progress) response (TRF-vA1 to IBCF-vA1)

```

SIP/2.0 183 Session Progress

To:
From:
P-Asserted-Identity:
Contact:
CSeq:
Require:
Record-Route: <One or more entries with entities of the remote network>,
    <sip:ic-T1.interconnection-T.net:5070;lr>,
    <sip:ibcf-vA1.visited-A.net:5070;lr>,<sip:trf-vA1.visited-A.net:5070;lr>,
    <sip:ibcf-vA1.visited-A.net:5070;lr>,<sip:ic-A1.interconnection-A.net;lr>,
    <sip:ibcf-hA1.home-A.net:5070;lr>,<sip:scscf-hA1.home-A.net:5070;lr>,
    <sip:as-hA1.home-A.net:5070;lr>,<sip:scscf-hA1.home-A.net:5070;lr>,
    <sip:ibcf-hA1.home-A.net:5070;lr>,<sip:ic-A1.interconnection-A.net;lr>,
    <sip:ibcf-vA1.visited-A.net;lr>,<sip:pcscf-vA1.visited-A.net;lr>
P-Access-Network-Info:
P-Charging-Vector: icid-value="AyretyU0dm+602IrT5tAFrbHLso=023551024";orig-oi="Type lhome-a";term-oi="Type lvisited-a";loopback

Via: SIP/2.0/UDP ibcf-vA1.visited-A.net;branch=z9hG4bK351g45.9
Via: SIP/2.0/UDP ic-A1.interconnection-A.net;branch=z9hG4bK351g45.8
Via: SIP/2.0/UDP ibcf-hA1.home-A.net;branch=z9hG4bK351g45.7
Via: SIP/2.0/UDP scscf-hA1.home-A.net;branch=z9hG4bK351g45.6
Via: SIP/2.0/UDP as-hA1.home-A.net;branch=z9hG4bK351g45.5
Via: SIP/2.0/UDP scscf-hA1.home-A.net;branch=z9hG4bK351g45.4
Via: SIP/2.0/UDP ibcf-hA1.home-A.net;branch=z9hG4bK351g45.3
Via: SIP/2.0/UDP ic-A1.interconnection-A.net;branch=z9hG4bK351g45.2
Via: SIP/2.0/UDP ibcf-vA1.visited-A.net;branch=z9hG4bK351g45.1
Via: SIP/2.0/UDP pcscf-vA1.visited-A.net:5060;branch=z9hG4bKnas56565
Via: SIP/2.0/UDP [5555::aaa:bbb:ccc:ddd];branch=z9hG4bKnashds7

Content-Type:
Content-Length: (...)

c=
m=
a=

```

```
a=
a=
a=
a=
```

For the content of the SDP see table 5.4.2-15.

Other SIP header fields according to 3GPP TS 24.229 [4].

P-Charging-Vector: The TRF-vA1 removes the "transit-ioi" header field parameter and replaces the "orig-ioi" received from the IBCF-vA1 with the "orig-ioi" received from the home network in the INVITE request and replaces the "term-ioi" with the received IOI type 2 value to a IOI type 1 value identifying the visited network vA. The TRF-vA1 adds the loopback-indication header field parameter.

17.183 (Session Progress) response (IBCF-vA1 to IC-A1) - see example in table 5.4.2-17.

When the IBCF-vA1 receives the 183 (Session Progress) response the IBCF-vA1 updates the SDP as follows:

- The c=IN IP4 192.0.2.4 is replaced with an invalid IPv4 address, i.e. c=IN IP4 0.0.0.0, since the IP realm on visited network side and the IC network side are not the same hence the received IP address is not valid on the IC side. The received SDP answer includes connection address information for the media line that is a valid IP address other than the unspecified address (i.e., IPv4: "0.0.0.0", IPv6: "invalid.invalid").

The IBCF-vA1 sends the 183 (Session Progress) response according to 3GPP TS 24.229 [4] towards the S-CSCF-hA1 via the IC-A1 and IBCF-hA1. Neither the IC-A1 nor IBCF-hA1 updates the SDP.

NOTE 7: If the interconnection network is SIP-unaware, IC-A1 is omitted.

Table 5.4.2-17: SIP 183 (Session Progress) response (IBCF-vA1 to IC-A1)

SIP/2.0 183 Session Progress

```
To:
From:
P-Asserted-Identity:
Contact:
CSeq:
Require:
Record-Route: <One or more entries with entities of the remote network>,
  <sip:ic-T1.interconnection-T.net:5070;lr>,
  <sip:ibcf-vA1.visited-A.net:5070;lr>, <sip:trf-vA1.visited-A.net:5070;lr>,
  <sip:ibcf-vA1.visited-A.net:5070;lr>, <sip:ic-A1.interconnection-A.net;lr>,
  <sip:ibcf-hA1.home-A.net:5070;lr>, <sip:scscf-hA1.home-A.net:5070;lr>,
  <sip:as-hA1.home-A.net:5070;lr>, <sip:scscf-hA1.home-A.net:5070;lr>,
  <sip:ibcf-hA1.home-A.net:5070;lr>, <sip:ic-A1.interconnection-A.net;lr>,
  <sip:ibcf-vA1.visited-A.net;lr>, <sip:pcscf-vA1.visited-A.net;lr>
```

P-Access-Network-Info:

P-Charging-Vector:

```
Via: SIP/2.0/UDP ic-A1.interconnection-A.net;branch=z9hG4bK351g45.8
Via: SIP/2.0/UDP ibcf-hA1.home-A.net;branch=z9hG4bK351g45.7
Via: SIP/2.0/UDP scscf-hA1.home-A.net;branch=z9hG4bK351g45.6
Via: SIP/2.0/UDP as-hA1.home-A.net;branch=z9hG4bK351g45.5
Via: SIP/2.0/UDP scscf-hA1.home-A.net;branch=z9hG4bK351g45.4
Via: SIP/2.0/UDP ibcf-hA1.home-A.net;branch=z9hG4bK351g45.3
Via: SIP/2.0/UDP ic-A1.interconnection-A.net;branch=z9hG4bK351g45.2
Via: SIP/2.0/UDP ibcf-vA1.visited-A.net;branch=z9hG4bK351g45.1
Via: SIP/2.0/UDP pcscf-vA1.visited-A.net:5060;branch=z9hG4bK351g45.1
Via: SIP/2.0/UDP [5555::aaa:bbb:ccc:ddd];branch=z9hG4bK351g45.1
```

Content-Type:

Content-Length: (...)

```
c=IN IP6 invalid.invalid
m=audio 16511 RTP/AVP 97 98
a=
a=a=
a=
a=visited-realm:1 visited-A1.net IN IP6 [5555::aaa:bbb:ccc:ddl]16511
```

Other SIP header fields and SDP according to 3GPP TS 24.229 [4].

SDP MIME body: The IBCF-vA1 detects that the realm is different towards the IC-A1 than in the "a=visited-realm" attribute and changes the IP address to c=IN IP6 invalid.invalid.

18. 183 (Session Progress) response (IC-A1 to IBCF-hA1) - see example in table 5.4.2-18.

NOTE 8: If the interconnection network is SIP-unaware, step 18 is skipped.

Table 5.4.2-18: SIP 183 (Session Progress) response (IC-A1 to IBCF-hA1)

```
SIP/2.0 183 Session Progress

To:
From:
P-Asserted-Identity:
Contact:
CSeq:
Require:
Record-Route: <One or more entries with entities of the remote network>,
  <sip:ic-T1.interconnection-T.net:5070;lr>,
  <sip:ibcf-vA1.visited-A.net:5070;lr>, <sip:trf-vA1.visited-A.net:5070;lr>,
  <sip:ibcf-vA1.visited-A.net:5070;lr>, <sip:ic-A1.interconnection-A.net;lr>,
  <sip:ibcf-hA1.home-A.net:5070;lr>, <sip:scscf-hA1.home-A.net:5070;lr>,
  <sip:as-hA1.home-A.net:5070;lr>, <sip:scscf-hA1.home-A.net:5070;lr>,
  <sip:ibcf-hA1.home-A.net:5070;lr>, <sip:ic-A1.interconnection-A.net;lr>,
  <sip:ibcf-vA1.visited-A.net;lr>, <sip:pcscf-vA1.visited-A.net;lr>
P-Access-Network-Info:
P-Charging-Vector: icid-value="AyretyU0dm+602IrT5tAFrbHLso=023551024";orig-ioi="Type 1home-a";term-
ioi="Type 1visited-a";transit-ioi="ICa.1";loopback

Via: SIP/2.0/UDP ibcf-hA1.home-A.net;branch=z9hG4bK351g45.7
Via: SIP/2.0/UDP scscf-hA1.home-A.net;branch=z9hG4bK351g45.6
Via: SIP/2.0/UDP as-hA1.home-A.net;branch=z9hG4bK351g45.5
Via: SIP/2.0/UDP scscf-hA1.home-A.net;branch=z9hG4bK351g45.4
Via: SIP/2.0/UDP ibcf-hA1.home-A.net;branch=z9hG4bK351g45.3
Via: SIP/2.0/UDP ic-A1.interconnection-A.net;branch=z9hG4bK351g45.2
Via: SIP/2.0/UDP ibcf-vA1.visited-A.net;branch=z9hG4bK351g45.1
Via: SIP/2.0/UDP pcscf-vA1.visited-A.net:5060;branch=z9hG4bKnas56565
Via: SIP/2.0/UDP [5555::aaa:bbb:ccc:ddd];branch=z9hG4bKnashds7

Content-Type:
Content-Length: (...)

c=
m=
a=
a=
a=
a=
a=

For the content of the SDP see table 5.4.2-17.

Other SIP header fields and SDP according to 3GPP TS 24.229 [4].
```

P-Charging-Vector: The IC-A1 adds the "transit-ioi" header field parameter identifying the interconnection network (i.e. ICa.1).

19-24. 183 (Session Progress) response (loop from IBCF-hA1 to IBCF-vA1 via S-CSCF-hA1, AS-hA1, S-CSCF-hA1, IBCF-hA1 and IC-A1) handling.

The procedures of 3GPP TS 24.229 [4] apply. The main changes are:

- the deduction of Via header field; and
- the P-Charging-Vector is updated with IOI type values corresponding to the INVITE request along the signalling path (see clause 4.3.1.4).

NOTE 9: If the interconnection network is SIP-unaware, step 24 is skipped.

The IBCF-hA1 and the IC-A1 releases resources reserved in the media gateway. The content of the SDP answer is kept unchanged.

25. 183 (Session Progress) response (IBCF-vA1 to P-CSCF-vA1) - see example in table 5.4.2-25.

When the IBCF-vA1 receives the 183 (Session Progress) response the IBCF- vA1 updates the SDP.

The IBCF- vA1:

- replaces the received invalid IPv6 address with the IP address received in the visited-realm instance 1;
- removes all OMR specific attributes since the SDP offer from P-CSCF-A did not contain any OMR specific attributes;
- releases resources reserved in the TrGW.

The IBCF-vA1 sends the 183 (Session Progress) response according to 3GPP TS 24.229 [4] to the P-CSCF-vA1.

Table 5.4.2-25: SIP 183 (Session Progress) response (IBCF-vA1 to P-CSCF-vA1)

<pre> SIP/2.0 183 Session Progress To: From: P-Asserted-Identity: Contact: CSeq: Require: Record-Route: <One or more entries with entities of the remote network>, <sip:ic-T1.interconnection-T.net:5070;lr>, <sip:ibcf-vA1.visited-A.net:5070;lr>, <sip:trf-vA1.visited-A.net:5070;lr>, <sip:ibcf-vA1.visited-A.net:5070;lr>, <sip:ic-A1.interconnection-A.net;lr>, <sip:ibcf-hA1.home-A.net:5070;lr>, <sip:scscf-hA1.home-A.net:5070;lr>, <sip:as-hA1.home-A.net:5070;lr>, <sip:scscf-hA1.home-A.net:5070;lr>, <sip:ibcf-hA1.home-A.net:5070;lr>, <sip:ic-A1.interconnection-A.net;lr>, <sip:ibcf-vA1.visited-A.net;lr>, <sip:pcscf-vA1.visited-A.net;lr> P-Charging-Vector: icid-value="AyretyU0dm+602IrT5tAFrbHLso=023551024";orig-ioi="Type lvisited-a";term-ioi="Type lhome-a";transit-ioi="ICa.1";loopback Via: SIP/2.0/UDP pcscf-vA1.visited-A.net:5060;branch=z9hG4bKnas56565 Via: SIP/2.0/UDP [5555::aaa:bbb:ccc:ddd];branch=z9hG4bKnashds7 Content-Type: Content-Length: (...) c=IN IP6 [5555::aaa:bbb:ccc:ddl] m=audio 16511 RTP/AVP 97 98 a= a= a= a= Other SIP header fields and SDP according to 3GPP TS 24.229 [4]. </pre>

26. 183 (Session Progress) response (P-CSCF-vA1 to UE-A) - see example in table 5.4.2-26.

Table 5.4.2-26: SIP 183 (Session Progress) response (P-CSCF-vA1 to UE-A)

<pre> SIP/2.0 183 Session Progress To: From: P-Asserted-Identity: Contact: CSeq: Require: Record-Route: <One or more entries with entities of the remote network>, <sip:ic-T1.interconnection-T.net:5070;lr>, <sip:ibcf-vA1.visited-A.net:5070;lr>, <sip:trf-vA1.visited-A.net:5070;lr>, <sip:ibcf-vA1.visited-A.net:5070;lr>, <sip:ic-A1.interconnection-A.net;lr>, <sip:ibcf-hA1.home-A.net:5070;lr>, <sip:scscf-hA1.home-A.net:5070;lr>, <sip:as-hA1.home-A.net:5070;lr>, <sip:scscf-hA1.home-A.net:5070;lr>, <sip:ibcf-hA1.home-A.net:5070;lr>, <sip:ic-A1.interconnection-A.net;lr>, <sip:ibcf-vA1.visited-A.net;lr>, <sip:pcscf-vA1.visited-A.net;lr> Via: SIP/2.0/UDP [5555::aaa:bbb:ccc:ddd];branch=z9hG4bKnashds7 Content-Type: Content-Length: (...) </pre>
--

c=
m=
a=
a=
a=
a=

Other SIP header fields and SDP according to 3GPP TS 24.229 [4].

27. PRACK request (UE-A to IC-T1 via all intermediate nodes) and 200 OK response (IC-T1 to UE-A via all intermediate nodes).

The PRACK request and the 200 (OK) response to the PRACK request are sent without any SDP offer/SDP answer between the UE-A and the IC-T1 according to 3GPP TS 24.229 [4].

28. Resource Reservation.

29. UPDATE request (UE-A to IC-T1 via all intermediate nodes) and 200 OK response (IC-T1 to UE-A via all intermediate nodes).

The UPDATE request and the 200 (OK) response to the UPDATE request are sent with the same SDP offer and SDP answer as in the initial SIP INVITE request and the 183 (Session Progress) response but now indicating that resources are reserved at the UE-A. The SDP updates are the same as in steps 1 – 26.

30. UPDATE request (IC-T1 to UE-A via all intermediate nodes) and 200 OK response (UE-A to IC-T1 via all intermediate nodes).

The UPDATE request and the 200 (OK) response to the UPDATE request are sent according to the rules described in 3GPP TS 29.079 [5].

5.5 Routing when the originating and terminating user reside in the same home network

This clause describes routing when the originating and terminating user reside in the same home network.

5.6 Routing from originating home to terminating home network

The interconnection (IC) and routing aspects of the originating home network to the terminating home network including transit networks use case do not differ from any other session set-up between any two wire-line or mobile networks. The IC might be established via CS-IC or PS-IC. The routing might be based on the destination given by the SIP Request-URI or the Called Party Number parameter in case of CS-IC.

5.7 Routing from originating visited network to terminating home network

This clause describes routing from an originating remote network to the terminating home network A including transit network scenarios.

The signalling and the media path between the originating remote network and the terminating home network A might be based on SIP/PS or CS/TDM interconnection interfaces.

NOTE 1: This is different from some other IC scenarios discussed in this document for which SIP/PS interconnection is a mandatory pre-requisite.

The scenario appears after the "originating roaming without loopback" according to clause 5.3 or the "originating roaming with loopback" according to clause 5.4 has taken place. I.e. the call has already been set-up from the P-CSCF in the originating visited network via IMS in the originating home network back to the TRF in the originating visited network.

From viewpoint of the originating remote network it doesn't matter whether the call originates from an own user served by an own S-CSCF or from a roaming inbound user served by the TRF. In both cases the originating remote network will set-up an outgoing call leg via an IBCF acting as an exit point (MGCF, if CS IC applies) towards the terminating

network A. Hereby the path might be established via IC networks. The destination (i.e. in this case the address of the terminating home network) used for routing is given by the request line provided by the originating remote network (CdPty in case of CS IC).

From the viewpoint of the IC network and from the viewpoint of the terminating home network A the routing and call handling does not differ from calls originated in any other network. I.e. the fact that the call is originated by a roamer is neither visible nor required/used for any proceeding.

NOTE 2: Even if a calling party identity (P-Asserted-Identity header field, From header field) is present and not within the number range of the originating visited network this does not indicate that the originating party is an inbound roamer within the originating visited network which sets up the call. Number portability and forwarding services might result in the same effect. In any case a mismatch between the calling party identity and address range of the originating visited network does not result in any deviating routing procedures within IC or terminating home network.

5.8 Routing in terminating home network when user resides in this network

This use case does not involve any interconnection network and is out of scope of this technical report.

5.9 Routing from terminating home network to the terminating visited network

This clause describes routing from the terminating home network to the terminating visited network including the traversal of transit network between the terminating home network and the terminating visited network.

Preconditions:

- The UE-A is registered as described in clause 5.2.
- In the originating side the call can be routed either as a call without loopback as described in clause 5.3 or with loopback as described in clause 5.4.
- The coding examples assume that the originating network, the interconnection network and the terminating network are within the trust domain.

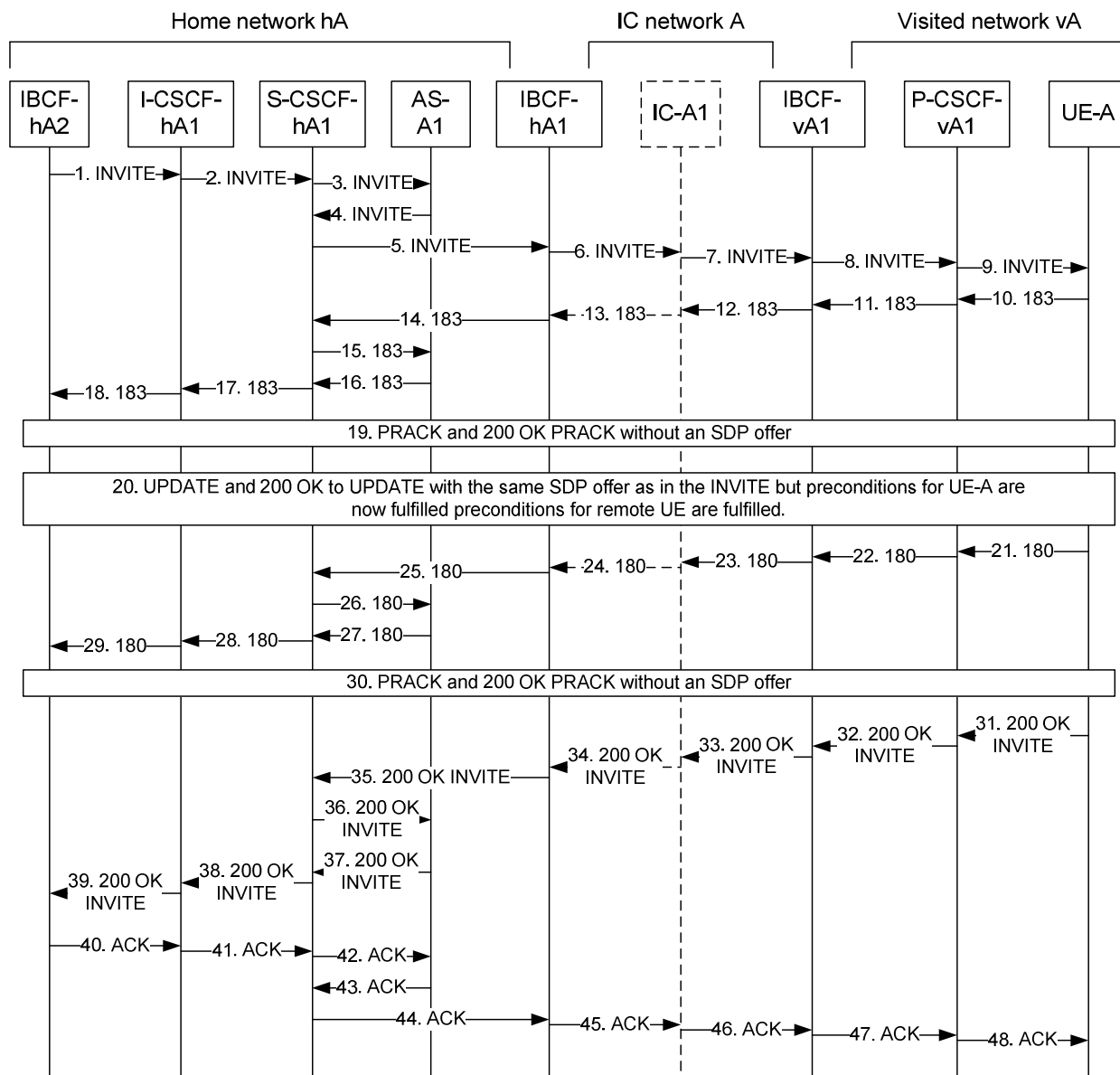

Figure 5.9-1: Mobile terminating call from terminating home network to terminating visited network

The steps of the flow are as follows:

1. INVITE request (IBCF-hA2 to I-CSCF-hA1) - see example in table 5.9-1.

An initial INVITE request is received by the IBCF-hA2. Due to bilateral agreement all relevant SIP header fields are included. The IBCF-hA2 removes any received Route header field pointing to itself and forwards the call to the I-CSCF-hA1 according to 3GPP TS 24.229 [4].

Table 5.9-1: INVITE request (IBCF-hA2 to I-CSCF-hA1)

```
INVITE sip:+12375551111@home-A.net;user=phone;iotl=homeA-homeB SIP/2.0
To: <tel:+12375551111>
From: <tel:+4687197378>;tag=4fa3
P-Asserted-Identity: <tel:+4687197378>,<sip:+4687197378@home-A.net;user=phone>;
P-Asserted-Service: urn:urn-7:3gpp-service.ims.icsi.mmtel
Contact: <sip:[5555::bbb:ccc:ddd:aaa]>
CSeq: 1 INVITE
Supported: 100rel,precondition
Route: <sip:icscf-hA1.home-A.net;lr>
Record-Route: <sip:ibcf-hA2.home-A.net;lr>,<ic-T1.interconnection-T.net;lr>,<One or more entries with entities of the originating network>
```

```

P-Access-Network-Info: 3GPP-E-UTRAN-TDD;utran-cell-id-3gpp=234151D0FCE22,3GPP-E-UTRAN-TDD; utran-
cell-id-3gpp=234151D0FCE22;network-provided;local-time-zone="UTC+01:00";daylight-saving-time="01"
P-Charging-Vector: icid-value="AyretyU0dm+602IrT5tAFrbHLso=023551024";orig-ioi="home-r";transit-
ioi="Ict.1"

Via: SIP/2.0/UDP ibcf-hA2.home-R.net;branch=z9hG4bK351g45.13
Via: SIP/2.0/UDP ic-T1.interconnection-T.net;branch=z9hG4bK351g45.12
Via: <One or more entries with entities of the originating network>

Other SIP header fields and SDP according to 3GPP TS 24.229 [4]

```

- Request-URI:** Contains the destination address for the INVITE request. In this example a SIP URI with user=phone is used. It could be also a tel URI. The "iotl" SIP URI parameter indicates that this is call between two home networks and that the URI in the Request-URI is the destination. If the remote UE is roaming and loopback routing is used, the "iotl" SIP URI parameter would be set to "visitedA-homeB".
- Supported:** The Supported header field contains the option-tag "100rel" indicating support of the reliable provisional responses and the option-tag "precondition" indicating support of the precondition mechanism.
- P-Charging-Vector:** The P-Charging-Vector contains the type 2 "orig-ioi" of the call which is either the remote UE's home network or the remote UE's visited network when loopback applies. In this example the "orig-ioi" contains the remote UE's home network. Contains the "transit-ioi" header field parameter identifying the interconnection network.
- Contact:** The Contact header field contains in this example the IP address of the remote UE. But due to network rules it could be also the IP address a downstream B2BUA.
- Route:** The IBCF-hA2 adds a Route header field which points to I-CSCF-hA1 in the home network hA.
- Record-Route:** Depending on the policy of the intermediate network the content of the Record-Route header field can vary. The Record-Route header field includes all entries included in the received INVITE request plus an entry of the incoming IBCF-hA2.
- Via:** The Via header field includes all entries included in the received INVITE request plus the entry of the incoming IBCF-hA2.

2. INVITE request (I-CSCF-hA1 to S-CSCF-hA1) - see example in table 5.9-2.

When the I-CSCF-hA1 receives the initial INVITE request it queries the SLF/HSS to identify the correct S-CSCF where the call has to be routed to. Due to normal routing procedures the S-CSCF will be allocated by the HSS procedures as described in 3GPP TS 24.229 [4].

Table 5.9-2: INVITE request (I-CSCF-hA1 to S-CSCF-hA1)

```

INVITE tel:+12375551111 SIP/2.0

To:
From:
P-Asserted-Identity:
P-Asserted-Service:
Contact:
CSeq:
Supported:
Route: <sip:home-abc@scscf-hA1.home-A.net:5070;lr>
Record-Route: <sip:ibcf-hA2.home-A.net;lr>,<sip:ic-T1.interconnection-T.net;lr>,<One or more entries
with entities of the originating network>
P-Access-Network-Info:
P-Charging-Vector:
or when loopback in the originating path apply then:
P-Charging-Vector:

Via: SIP/2.0/UDP icscf-hA1.home-A.net;branch=z9hG4bK351g45.13a
Via: SIP/2.0/UDP ibcf-hA2.home-A.net;branch=z9hG4bK351g45.13
Via: SIP/2.0/UDP ic-T1.interconnection-T.net;branch=z9hG4bK351g45.12
Via: <One or more entries with entities of the originating network>

Other SIP header fields and SDP according to 3GPP TS 24.229 [4].

```

Request-URI: Contains the destination address for the INVITE request. In this case the I-CSCF-hA1 changes the URI from a SIP URI user=phone to a tel URI as described in 3GPP TS 24.229 [4].

Via: The I-CSCF-hA1 adds a Via header field.

3.-4. INVITE request (S-CSCF-hA1 to AS-hA1 to S-CSCF-hA1).

The S-CSCF applies the filter criteria to involve the AS for terminating services.

Record-Route: The entries to this header field need to be added based on the related dip's to the AS. The AS could behave as B2BUA. In such case the AS could store the entries and setup a new Record-Route header field only with the AS URI as an entry. Both the AS-hA1 and the S-CSCF-hA1 adds Record-Route header fields.

P-Charging-Vector: Towards the AS-hA1 the P-Charging-Vector header field contains the type 3 "orig-ioi" identifying the network of the S-CSCF-hA1 sending the request. Towards the S-CSCF-hA1 the P-Charging-Vector header field contains the type 3 "orig-ioi" identifying the network of the AS-hA1 sending the request.

Route: The S-CSCF-hA1 adds a Route header field identifying the selected AS-hA1 and S-CSCF-hA1 for routing back.

Via: Both the AS-hA1 and the S-CSCF-hA1 adds Via header fields.

Editor's note: The behaviour of the transit-ioi value is currently discussed and needs further consideration how the S-CSCF to AS correlation is describes.

5. INVITE request (S-CSCF-hA1 to IBCF-hA1) - see example in table 5.9-5.

Since the call is a terminating call no further specific information is needed for termination of the call.

The S-CSCF-hA1 sends the INVITE request according to 3GPP TS 24.229 [4] to the IBCF-hA1.

Table 5.9-5: INVITE request (S-CSCF-hA1 to IBCF-hA1)

```
INVITE sip:[5555::ddd:aaa:ccc:bbb] SIP/2.0
To:
From:
P-Asserted-Identity:
P-Asserted-Service:
Contact:
CSeq:
Supported:
Route:< sip:home-abc@ibcf-hA1.home-A.net:5070;lr>,
      < sip:proxy-abc@ic-A1.interconnection-A.net:5070;lr>,
      < sip:visit-abc@ibcf-vA1.visited-A.net:5070;lr>,
      < sip:visit-xyz@pcscf-vA1.visited-A.net:5070;lr;iotl=homeB-visitedB>
Record-Route: < sip:scscf-hA1.home-A.net;lr>,
              < sip:as-hA1.home-A.net;lr>, < sip:scscf-hA1.home-A.net;lr>,
              < sip:ibcf-hA2.home-A.net;lr>, < sip:ic-T1.interconnection-T.net;lr>, < One or more entries with
entities of the originating network>

P-Access-Network-Info:
P-Charging-Vector: icid-value="AyretyU0dm+602IrT5tAFrbHLso=023551024";orig-ioi="Type 1home-a"

Via: SIP/2.0/UDP scscf-hA1.home-A.net;branch=z9hG4bK351g45.16
Via: SIP/2.0/UDP as-hA1.home-A.net;branch=z9hG4bK351g45.15
Via: SIP/2.0/UDP scscf-hA1.home-A.net;branch=z9hG4bK351g45.14
Via: SIP/2.0/UDP icscf-hA1.home-A.net;branch=z9hG4bK351g45.13a
Via: SIP/2.0/UDP ibcf-hA2.home-A.net;branch=z9hG4bK351g45.13
Via: SIP/2.0/UDP ic-T1.interconnection-T.net;branch=z9hG4bK351g45.12
Via: < One or more entries with entities of the originating network>

Other SIP header fields and SDP according to 3GPP TS 24.229 [4].
```

Request-URI: The S-CSCF-hA1 replaces the received tel URI with the SIP URI received in the Contact header field from the UE-A during the registration.

- Route:** The S-CSCF includes a Route header field with the routing information received in the Path header field during registration.
- P-Charging-Vector:** The S-CSCF-hA1 replaces the received IOI type 3 value in the "orig-ioi" header field parameter with a IOI type 1 value identifying the home network of the UE-A.
- Via:** The S-CSCF-hA1 adds a Via header field.
- Record-Route:** The S-CSCF-hA1 adds a Record-Route header field.

6. INVITE request (IBCF-hA1 to IC-A1) see example in table 5.9-6.

The IBCF-hA1 applies local policy which is dependent on the operator policy for roaming calls with that specific visited network and the intermediate transit network. Header fields can be deleted or anonymized.

The IBCF-hA1 selects, based on the Route header field as shown table 5.9-5 or in cases where the Path header field received during registration only points to the visited network, based on local policy, to route the INVITE request via IC network A and sends the INVITE request according to 3GPP TS 24.229 [4] to the IC-A1.

The IBCF-hA1 determines the next hop IP address from the URI in the first entry of the Route header field either by configured information or using a DNS query according to IETF RFC 3263 [13]. If the subsequent interconnection network is SIP-aware, the determined IP address will belong to the SIP proxy IC-A1. Otherwise the determined IP address will point to IBCF-vA1 and step 7 is skipped (not reflected in message details below).

The procedures apply to 3GPP TS 24.229 [4].

Table 5.9-6: INVITE request (IBCF-hA1 to IC-A1)

```
INVITE sip:[5555::ddd:aaa:ccc:bbb] SIP/2.0

To:
From:
P-Asserted-Identity:
P-Asserted-Service:
Contact:
CSeq:
Supported:
Route:<sip:proxy-abc@ic-A1.interconnection-A.net:5070;lr>,
      <sip:visit-abc@ibcf-vA1.visited-A.net:5070;lr>,
      <sip:visit-xyz@pcscf-vA1.visited-A.net:5070;lr;iotl=homeB-visitedB>
Record-Route:<sip:ibcf-hA1.home-A.net;lr>,
      <sip:scscf-hA1.home-A.net;lr>,
      <sip:as-hA1.home-A.net;lr>,<sip:scscf-hA1.home-A.net;lr>,
      <sip:ibcf-hA2.home-A.net;lr>,<sip:ic-T1.interconnection-T.net;lr>,<One or more entries with
entities of the originating network>

P-Access-Network-Info:
P-Charging-Vector:

Via: SIP/2.0/UDP ibcf-hA1.home-A.net;branch=z9hG4bK351g45.17
Via: SIP/2.0/UDP scscf-hA1.home-A.net;branch=z9hG4bK351g45.16
Via: SIP/2.0/UDP as-hA1.home-A.net;branch=z9hG4bK351g45.15
Via: SIP/2.0/UDP scscf-hA1.home-A.net;branch=z9hG4bK351g45.14
Via: SIP/2.0/UDP icscf-hA1.home-A.net;branch=z9hG4bK351g45.13a
Via: SIP/2.0/UDP ibcf-hA2.home-A.net;branch=z9hG4bK351g45.13
Via: SIP/2.0/UDP ic-T1.interconnection-T.net;branch=z9hG4bK351g45.12
Via: <One or more entries with entities of the originating network>

Other SIP header fields and SDP according to 3GPP TS 24.229 [4].
```

- Via:** The IBCF-hA1 adds a Via header field.
- Record-Route:** The IBCF-hA1 adds a Record-Route header field.

7. INVITE request (IC-A1 to IBCF-vA1) - see example in table 5.9-7.

NOTE 1: If the interconnection network is SIP-unaware, step 7 is skipped (not reflected in message details below).

Based on the Route header field, the IC-T1 selects an entry point (IBCF-vA1) of the visited IMS network vA and sends the INVITE request according to 3GPP TS 24.229 [4] to the IBCF-vA1.

In our example the entry point of visited network vA is already included in the received Route header field. However, the IC- A1 can add a Route header field entry pointing to the entry point of the visited network vA if the entry point is missing.

Table 5.9-7: INVITE request (IC-A1 to IBCF-vA1)

```
INVITE sip:[5555::ddd:aaa:ccc:bbb] SIP/2.0

To:
From:
P-Asserted-Identity:
P-Asserted-Service:
Contact:
CSeq:
Supported:
Route:<sip:visit-abc@ibcf-vA1.visited-A.net:5070;lr>,
      <sip:visit-xyz@pcscf-vA1.visited-A.net:5070;lr;iotl=homeB-visitedB>

Record-Route: <sip:ic-A1.interconnection-A.net;lr>,
               <sip:ibcf-hA1.home-A.net;lr>,<sip:scscf-hA1.home-A.net;lr>,
               <sip:as-hA1.home-A.net;lr>,<sip:scscf-hA1.home-A.net;lr>,
               <sip:ibcf-hA2.home-A.net;lr>,<ic-T1.interconnection-T.net;lr>,<One or more entries with entities
of the originating network>

P-Access-Network-Info:
P-Charging-Vector: icid-value="AyretyU0dm+6O2IrT5tAFrbHLso=023551024";orig-ioi="Type 1home-
a";transit-ioi="ICa.1"

Via: SIP/2.0/UDP ic-A1.interconnection-A.net;branch=z9hG4bK351g45.18
Via: SIP/2.0/UDP ibcf-hA1.home-A.net;branch=z9hG4bK351g45.17
Via: SIP/2.0/UDP scscf-hA1.home-A.net;branch=z9hG4bK351g45.16
Via: SIP/2.0/UDP as-hA1.home-A.net;branch=z9hG4bK351g45.15
Via: SIP/2.0/UDP scscf-hA1.home-A.net;branch=z9hG4bK351g45.14
Via: SIP/2.0/UDP icscf-hA1.home-A.net;branch=z9hG4bK351g45.13a
Via: SIP/2.0/UDP ibcf-hA2.home-A.net;branch=z9hG4bK351g45.13
Via: SIP/2.0/UDP ic-T1.interconnection-T.net;branch=z9hG4bK351g45.12
Via: <One or more entries with entities of the originating network>

Other SIP header fields and SDP according to 3GPP TS 24.229 [4].
```

P-Charging-Vector: The IC-A1 adds the "transit-ioi" header field parameter identifying the interconnection network (i.e. ICa.1).

Via: The IC-A1 adds a Via header field (i.e. ic-A1.interconnection-A.net).

Record-Route: The IC-A1 adds a Record-Route header field (i.e. ic-A1.interconnection-A.net).

8. INVITE request (IBCF-vA1 to P-CSCF-vA1) - see example in table 5.9-8.

The IBCF-vA1 routes the call to the P-CSCF-vA1 as stated within the Route header field.

IBCF-vA1 applies local policy based on trust relationship with the transit network and SLA between home network carrier and visited network carrier.

If a "transit-ioi" header field parameter value exists within the P-Charging-Vector header field then the values can be forwarded or made void.

In this example, the IBCF-vA1 does not add any "transit-ioi" header field parameter in the P-Charging-Vector header field. However, the IBCF-vA1 adds the "transit-ioi" header field parameter based on local policy, when the "transit-ioi" identifying the preceding interconnection network is not included in the received request (e.g. when the preceding interconnection network is not an IMS transit network).

Table 5.9-8: INVITE request (IBCF-vA1 to P-CSCF-vA1)

```
INVITE sip:[5555::ddd:aaa:ccc:bbb] SIP/2.0

To:
From:
P-Asserted-Identity:
P-Asserted-Service:
Contact:
CSeq:
Supported:
```

```

Route:<sip:visit-xyz@pcscf-vA1.visited-A.net:5070;lr;iotl=homeB-visitedB>
Record-Route: <sip:ibcf-vA1.visited-A.net;lr>,<sip:ic-A1.interconnection-A.net;lr>,<
  <sip:ibcf-hA1.home-B.net;lr>,<sip:scscf-hA1.home-A.net;lr>,<
  <sip:as-hA1.home-B.net;lr>,<sip:scscf-hA1.home-A.net;lr>,<
  <sip:ibcf-hA2.home-A.net;lr>,<
  <sip:ic-T1.interconnection-T.net;lr>,<
  <One or more entries with entities of the originating network>

P-Access-Network-Info:
P-Charging-Vector:

Via: SIP/2.0/UDP ibcf-vA1.visited-A.net;branch=z9hG4bK351g45.19
Via: SIP/2.0/UDP ic-A1.interconnection-A.net;branch=z9hG4bK351g45.18
Via: SIP/2.0/UDP ibcf-hA2.home-A.net;branch=z9hG4bK351g45.17
Via: SIP/2.0/UDP scscf-hA1.home-A.net;branch=z9hG4bK351g45.16
Via: SIP/2.0/UDP as-hA1.home-A.net;branch=z9hG4bK351g45.15
Via: SIP/2.0/UDP scscf-hA1.home-A.net;branch=z9hG4bK351g45.14
Via: SIP/2.0/UDP icscf-hA1.home-A.net;branch=z9hG4bK351g45.13a
Via: SIP/2.0/UDP ibcf-hA2.home-A.net;branch=z9hG4bK351g45.13
Via: SIP/2.0/UDP ic-T1.interconnection-T.net;branch=z9hG4bK351g45.12
Via: <One or more entries with entities of the originating network>

Other SIP header fields and SDP according to 3GPP TS 24.229 [4].

```

Record-Route: The IBCF-vA1 adds a Record-Route header field (i.e. IBCF-vA1).

Via: The IBCF-vA1 adds a Via header field (i.e. IBCF-vA1).

9. INVITE request (P-CSCF-vA1 to UE-A) - see example in table 5.9-9.

The P-CSCF-vA1 routes the call to the UE-A as stated within Request-URI which contains the address of the UE-A.

Based on privacy settings within the INVITE request, the P-CSCF-vA1 applies privacy according to IETF RFC 3323 [27] and IETF RFC 3325 [28].

The P-CSCF-vA1 applies trust domain according to 3GPP TS 24.229 [4] clause 4.4. This will result in that some header fields will be removed. In our example the P-Charging-Vector header field and the P-Access-Network-Info header field are removed from the outgoing INVITE request.

The P-CSCF-vA1 sends the INVITE request according to 3GPP TS 24.229 [4] to the UE-A.

Table 5.9-9: INVITE request (P-CSCF-vA1 to UE-A)

```

INVITE sip:[5555::ddd:aaa:ccc:bbb] SIP/2.0

To:
From:
P-Asserted-Identity:
P-Asserted-Service:
Contact:
CSeq:
Supported:

Record-Route: <sip:pcscf-vA1.visited-A.net;lr>,<
  <sip:ibcf-vA1.visited-A.net;lr>,<sip:ic-A1.interconnection-A.net;lr>,<
  <sip:ibcf-hA1.home-A.net;lr>,<sip:scscf-hA1.home-A.net;lr>,<
  <sip:as-hA1.home-A.net;lr>,<sip:scscf-hA1.home-A.net;lr>,<
  <sip:ibcf-hA2.home-A.net;lr>,<
  <sip:ic-T1.interconnection-T.net;lr>,<
  <One or more entries with entities of the originating network>

Via: SIP/2.0/UDP pcscf-vA1.visited-A.net:5060;branch=z9hG4bK351g45.19
Via: SIP/2.0/UDP ibcf-vA1.visited-A.net;branch=z9hG4bK351g45.19
Via: SIP/2.0/UDP ic-A1.interconnection-A.net;branch=z9hG4bK351g45.18
Via: SIP/2.0/UDP ibcf-hA1.home-A.net;branch=z9hG4bK351g45.17
Via: SIP/2.0/UDP scscf-hA1.home-A.net;branch=z9hG4bK351g45.16
Via: SIP/2.0/UDP as-hA1.home-A.net;branch=z9hG4bK351g45.15
Via: SIP/2.0/UDP scscf-hA1.home-A.net;branch=z9hG4bK351g45.14
Via: SIP/2.0/UDP icscf-hA1.home-A.net;branch=z9hG4bK351g45.13a
Via: SIP/2.0/UDP ibcf-hA2.home-A.net;branch=z9hG4bK351g45.13
Via: SIP/2.0/UDP ic-T1.interconnection-T.net;branch=z9hG4bK351g45.12
Via: <One or more entries with entities of the originating network>

Other SIP header fields and SDP according to 3GPP TS 24.229 [4].

```

Via: The P-CSCF-vA1 adds a Via header field.

Record-Route: The P-CSCF-vA1 adds a Record-Route header field.

10-18. 183 (Session Progress) response (UE-A to IBCF-hA2 via all intermediate nodes in the Via header fields) - see example in table 5.9-10.

The UE-A sends a 183 (Session Progress) response since 100rel and preconditions are supported by the remote UE.

The routing towards the IBCF-hA2 is based on the Via header fields received by the UE-A in the initial INVITE request.

When the IBCF-hA2 receives the 183 (Session Progress) response, the IBCF-hA2 sends the 183 (Session Progress) response according to 3GPP TS 24.229 [4] towards the remote UE as described within clause 5.3 or clause 5.4 of this document and regarding the rules defined in 3GPP TS 24.229 [4].

The table 5.9-10 shows the content of the 183 (Session Progress) response when sent by IBCF-hA1.

Table 5.9-10: SIP 183 (Session Progress) response (UE-A to IBCF-hA1) in step 14

<pre> SIP/2.0 183 Session Progress To: <tel:+12375551111>;tag=654a From: <tel:+4687197378>;tag=4fa3 P-Asserted-Identity: <tel:+4687197378> Contact: <sip:[5555::ddd:aaa:ccc:bbb]> CSeq: 1 INVITE Require:100rel,precondition Via: SIP/2.0/UDP scscf-hA1.home-A.net;branch=z9hG4bK351g45.16 Via: SIP/2.0/UDP as-hA1.home-A.net;branch=z9hG4bK351g45.15 Via: SIP/2.0/UDP scscf-hA1.home-A.net;branch=z9hG4bK351g45.14 Via: SIP/2.0/UDP icscf-hA1.home-A.net;branch=z9hG4bK351g45.13a Via: SIP/2.0/UDP ibcf-hA2.home-A.net;branch=z9hG4bK351g45.13 Via: SIP/2.0/UDP ic-T1.interconnection-T.net;branch=z9hG4bK351g45.12 Via: <One or more entries with entities of the originating network> Record-Route: <sip:pcscf-vA1.visited-A.net;lr>, <sip:ibcf-vA1.visited-A.net;lr>, <sip:ic-A1.interconnection-A.net;lr>, <sip:ibcf-hA2.home-A.net;lr>, <sip:scscf-hA1.home-A.net;lr>, <sip:as-hA1.home-A.net;lr>, <sip:scscf-hA1.home-A.net;lr>, <sip:ibcf-hA2.home-A.net;lr>, <sip:ic-T1.interconnection-T.net;lr>, <One or more entries with entities of the originating network> P-Charging-Vector: icid-value="AyretyU0dm+602IrT5tAFrbHLso=023551024";orig-ioi="Type 1home- a";transit-ioi="ICa.1";term-ioi="Type 1visited-a" Other SIP header fields and SDP according to 3GPP TS 24.229 [4]. </pre>
--

Require: The UE-A inserts the Require header field containing the option-tag "100rel" indicating reliable sending of the 183 (Session Progress) response and the option-tag "precondition" indicating the usage of the precondition mechanism.

P-Charging-Vector: The settings of the IOI values are important:

- in step 11 the "term-ioi" header field parameter includes a type 1 IOI value which identifies the visited network of the terminating user (i.e. "visited-a"). The "orig-ioi" header field parameter is set to the same type 1 IOI value that was included in the initial INVITE request by the home network hA (i.e. "home-a") towards the terminating user;
- in step 12 no change of ioi values;
- in step 13-14 the "transit-ioi" header field parameter includes one or more values identifying the transit networks passed between the visited network A and home network A; In our example only one value identifying the interconnect network A is included. If no "transit-ioi" header field parameter is included in step 13, the IBCF-hA1 can include a "transit-ioi" header field parameter value identifying the preceding interconnect network.

- in step 15-16 the "term-ioi" header field parameter includes a type 3 IOI value (prefix "Type 3") which identifies the AS-hA1 network. The "orig-ioi" header field parameter is set to the same type 3 IOI value that was included in the initial INVITE request from the S-CSCF-hA1 to the AS-hA1, the "transit-ioi" is deleted by the S-CSCF based on the operator policy; and
- in steps 17-18 the "term-ioi" header field parameter includes a type 2 IOI value which identifies the home network hA. The "transit-ioi" header field parameter is not appearing. The S-CSCF removes received "transit-ioi" values, the IOI Type 1 or Type 3 in "orig-ioi" and "term-ioi" header field parameters. The "orig-ioi" header field parameter is set to the same type 2 IOI value that was included in the initial INVITE request from the remote home network or, in case of loopback, from the remote visited network. The "term-ioi" header field parameter is set to a Type 2 IOI value identifying the home network A.

NOTE 2: If the interconnection network is SIP-unaware, step 13 is skipped.

19. PRACK requests (IBCF-hA2 to UE-A via all intermediate nodes) and SIP 200 (OK) response to the SIP PRACK request (UE-A to IBCF-hA2 via all intermediate nodes).

The PRACK request and the 200 (OK) response to the PRACK request are sent without any SDP offer/SDP answer between the IBCF-hA2 and the UE-A according to 3GPP TS 24.229 [4]. The messages are sent via all intermediate nodes with the exception of I-CSCF-hA1.

20. UPDATE requests (IBCF-hA2 to UE-A via all intermediate nodes) and SIP 200 (OK) response to the SIP UPDATE request (UE-A to IBCF-hA2 via all intermediate nodes).

When resources are reserved in the access network of the remote UE, the IBCF-hA2 receives an UPDATE request from the remote network. The IBCF-hA2 forwards the request towards the UE-A. The messages are sent via all intermediate nodes with the exception of I-CSCF-hA1.

22-30. 180 (Ringing) response to the SIP INVITE request (UE-A to IBCF-hA2 via all intermediate nodes).

NOTE 3: If the interconnection network is SIP-unaware, step 24 is skipped. The messages are sent via all intermediate nodes including the I-CSCF-hA1.

31. PRACK requests (IBCF-hA2 to UE-A via all intermediate nodes) and SIP 200 (OK) response to the SIP PRACK request (UE-A to IBCF-hA2 via all intermediate nodes).

The PRACK request and the 200 (OK) response to the PRACK request are sent without any SDP offer/SDP answer between the UE-A and the IBCF-hA2 according to 3GPP TS 24.229 [4]. The messages are sent via all intermediate nodes with the exception of I-CSCF-hA1.

32-39. 200 (OK) response to the SIP INVITE request (IBCF-hA2 to UE-A).

NOTE 4: If the interconnection network is SIP-unaware, step 34 is skipped.

40-48. ACK requests (IBCF-hA2 to UE-A via all intermediate nodes).

The IBCF-hA2 receives an ACK request which acknowledges the 200 (OK) final response, from the remote network. The IBCF-hA2 forwards the ACK request to the UE-A according to 3GPP TS 24.229 [4].

NOTE 5: If the interconnection network is SIP-unaware, step 46 is skipped.

5.10 Insertion of service related media in the originating home network

5.10.1 General

This clause describes insertion of a service related media in the originating home network (i.e. invocation of MRFC/MRF).

3GPP TS 24.628 [22] describes how to include announcements into the path for IMS. There are a couple of options which have to be considered for roaming.

The following sections are showing some examples where service related media can be included. The examples will not cover all possible scenarios defined within 3GPP.

5.10.2 Insertion of service related media in the originating home network with loopback

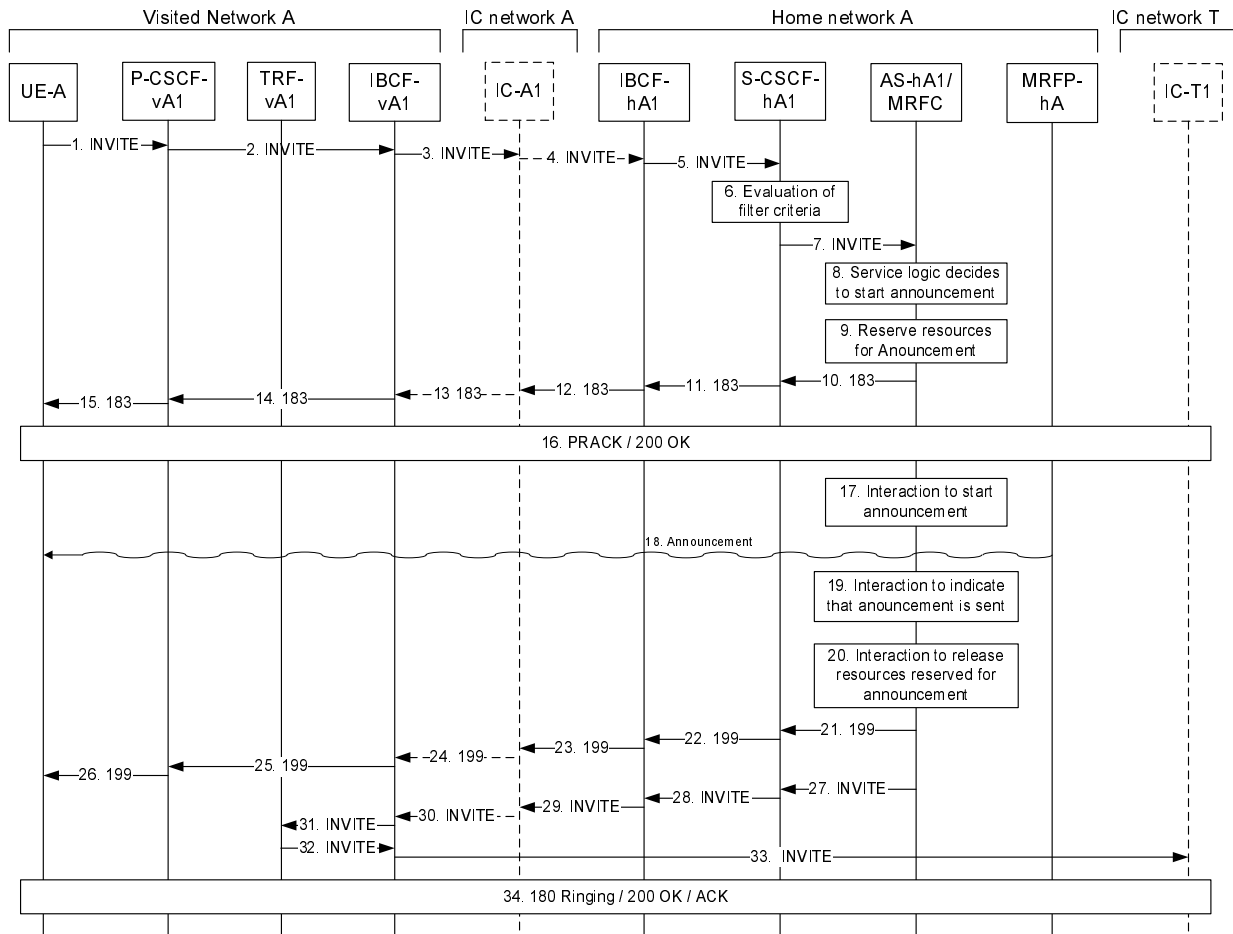

Figure 5.10.2-1: Announcement started during the establishment of a communication

The calling party initiates a communication by means of an INVITE request. The INVITE request is forwarded toward the called party.

Along the signalling path, created by the INVITE request, some service logic in an application server (AS) wants to send an announcement towards the calling party.

The flow is based on the assumptions that the Supported header field includes the option-tag "100rel", option-tag "precondition" and option-tag "199" indicating support of the reliable provisional responses, the precondition mechanism and the 199 (Early Dialog Terminated) provisional responses, respectively.

NOTE 1: If precondition mechanism is used, the procedures according to 3GPP TS 24.229 [4] apply.

The steps of the signalling flow are as follows:

1-5. INVITE request (UE-A to S-CSCF-hA1 via P-CSCF-vA1, IBCF-vA1, IC-A1 and IBCF-hA1).

The INVITE request is sent as described within clause 5.4.2.

NOTE 2: Upon generating an initial INVITE request using the precondition mechanism, the UE-A will indicate the support for the precondition mechanism and specify it using the Supported header field mechanism. If the desired QoS resources have not been reserved at the UE-A when constructing the SDP offer, the UE-A will indicate the related local preconditions for QoS as not met.

NOTE 3: If the interconnection network is SIP-unaware, step 4 is skipped.

6. Evaluation of initial filter criteria.

The S-CSCF-hA1 validates the service profile of this subscriber and evaluates the initial filter criteria. For this example, assume an application server/MRFC involvement.

7. INVITE request (S-CSCF-hA1 to AS-hA1 /MRFC) - see example in table 5.3.2-6.

The S-CSCF-hA1 applies the same procedure as in step 6 in clause 5.3.2.

8. Service logic in AS-hA1 /MRFC.

Service logic in the AS-hA1 decides to send an announcement to the calling party. In such a case the AS-hA1 acts as a B2BUA. Thus an early dialog for the announcement and two dialogs will be created in the final call state one from UE-A to the AS-hA1 and one from the AS-hA1 to the terminating UE which allows end-to-end communication.

9. MRFC-MRFP interaction.

The MRFC interacts with the MRFP in order to reserve resources for the announcement. As part of the interaction with MRFP the AS-hA1 receives the necessary media parameters e.g. IP address and port numbers and provide the IP address and port number for the calling party to the MRFP.

10-15. 183 (Session Progress) response (AS-hA1 to UE-A via S-CSCF-hA1, IBCF-hA1, IC-A1, IBCF-vA1 and P-CSCF-vA1).

The AS-hA1 sends a 183 (Session progress) response to S-CSCF-hA1. The response includes:

- a) an answer to the SDP received in the INVITE request;

NOTE 4: The AS-hA1 will include in the 183 (Session progress) response the Require header field with the option-tag "100rel" to indicate reliable sending of the 183 (Session Progress) response. If precondition mechanism is used, the AS-hA1 will include in the SDP answer an indication that the related local preconditions for QoS are fulfilled and will include in the Require header field the option-tag "precondition" to indicate the usage of the precondition mechanism.

- b) a P-Early-Media header field set to "sendonly" in case where only announcement will be played. For invoking an interactive voice response system a P-Early-Media header field is set to "sendrecv"; and
- c) the Require header field set to "100rel".

NOTE 5: If the interconnection network is SIP-unaware, step 13 is skipped.

16. PRACK request /200 (OK) response to the PRACK request (UE-A to AS-hA1 / AS-hA1 to UE-A).

NOTE 6: If precondition mechanism is used and the UE-A indicated in the initial SDP offer the related local preconditions for QoS as not met the UE-A will include in the SDP offer sent within the PRACK request an indication that the local preconditions for QoS are fulfilled. Otherwise, if local preconditions for QoS are not fulfilled when sending the PRACK request, the UE-A will use the UPDATE request to send the SDP offer indicating that the local preconditions for QoS are fulfilled, but that case is outside the scope of the present example.

17. MRFC-MRFP interaction to start the announcement.

The MRFC interacts with the MRFP in order to start the announcement.

18. Announcement sending (MRFP-hA to UE-A).

The MRFP sends the announcement towards the calling party.

19. MRFC-MRFP interaction to stop the announcement.

The complete announcement is sent and the MRFP interacts with the AS-hA1/MRFC in order to inform that the announcement is terminated.

20. MRFC-MRFP interaction to release the resources used for the announcement.

The MRFC interacts with the MRFP in order to release the resources used for the announcement.

21-26. 199 (Early Dialog Terminated) response (AS-hA1 to UE-A via S-CSCF-hA1, IBCF-hA1, IC-A1, IBCF-vA1 and P-CSCF-vA1) (optional).

If the originating UE-A has indicated support of the 199 (Early Dialog Terminated) response code, the AS-hA1 sends a 199 (Early Dialog Terminated) provisional response towards the originating UE-A to terminate the early dialog between itself and the UE-A.

NOTE 7: If the interconnection network is SIP-unaware, step 24 is skipped.

27. INVITE request (AS-hA1 to S-CSCF-hA1).

The AS-hA1 sends the INVITE request towards the S-CSCF-hA1. The INVITE request contains the same information as the INVITE request shown in table 5.4.2.-7, see step 7 in clause 5.4.2.

28-33. INVITE request (S-CSCF-hA1 to IC-T1 via IBCF-hA1, IC-A1, IBCF-vA1, TRF-vA1 and IBCF-vA1).

The S-CSCF-hA1 decides to loopback the INVITE request and forwards the call to the terminating home network via the originating visited network vA.

The SDP contained within the INVITE will be manipulated along the signalling path as shown in the example in 3GPP TS 29.079 [5] clause A.6.

NOTE 8: If the interconnection network is SIP-unaware, step 30 is skipped and step 33 is executed between IBCF-vA1 and IBCF-hB instead.

34. 180 (Ringing) response /200 (OK) response to the INVITE request / ACK request (IC-T1 to UE-A via IBCF-vA1, TRF-vA1, IBCF-vA1, IC-A1, IBCF-hA1, S-CSCF-hA1, AS-hA1, S-CSCF-hA1, IBCF-hA1, IC-A1, IBCF-vA1 and P-CSCF-vA1).

When the UE-A of the calling party receives the 200 (OK) response to the INVITE request and optional steps 21- 26 were not performed, the UE-A can regard the early dialog created for the announcement between the UE-A and the AS-hA1 as terminated. The UE-A sends the ACK request to acknowledge the reception of the 200 (OK) final response to the INVITE request.

NOTE 9: The loopback-indicator header field parameter is included in the P-Charging-Vector header field.

5.10.3 Insertion of service related media in the originating home network without loopback

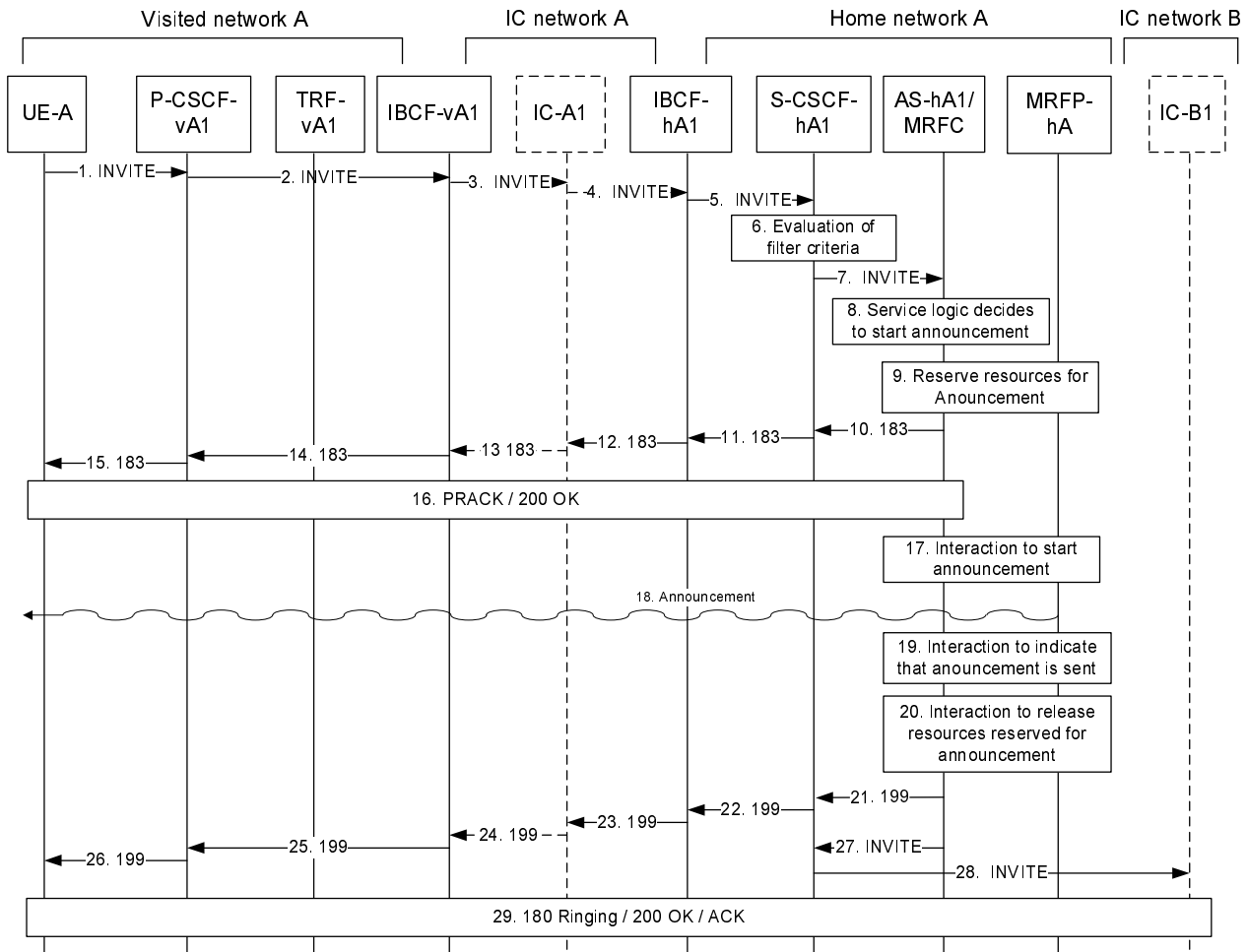

Figure 5.10.3-1: Announcement started during the establishment of a communication

The calling party initiates a communication by means of an INVITE request. The INVITE request is forwarded toward the called party.

Along the signalling path, created by the INVITE request, some service logic in an application server (AS) wants to send an announcement towards the calling party.

The flow is based on the assumptions that the Supported header field includes the option-tag "100rel", option-tag "precondition" and option-tag "199" indicating support of the reliable provisional responses, the precondition mechanism and the 199 (Early Dialog Terminated) provisional responses, respectively.

NOTE 1: If precondition mechanism is used, the procedures according to 3GPP TS 24.229 [4] apply.

The steps of the signalling flow are as follows:

1-5. INVITE request (UE-A to S-CSCF-hA1 via P-CSCF-vA1, IBCF-vA1, IC-A1 and IBCF-hA1).

The INVITE request is sent as described within clause 5.3.2.

NOTE 2: Upon generating an initial INVITE request using the precondition mechanism, the UE-A will indicate the support for the precondition mechanism and specify it using the Supported header field mechanism. If the desired QoS resources have not been reserved at the UE-A when constructing the SDP offer, the UE-A will indicate the related local preconditions for QoS as not met.

NOTE 3: If the interconnection network is SIP-unaware, step 4 is skipped.

6. Evaluation of initial filter criteria.

The S-CSCF-hA1 validates the service profile of this subscriber and evaluates the initial filter criteria. For this example, assume an application server/MRFC involvement.

7. INVITE request (S-CSCF-hA1 to AS-hA1 /MRFC) - see example in table 5.3.2-6.

The S-CSCF-hA1 applies the same procedure as in step 6 in clause 5.3.2.

8. Service logic in AS-hA1 /MRFC.

Service logic in the AS-hA1 decides to send an announcement to the calling party. In such a case the AS-hA1 acts as a B2BUA. Thus an early dialog for the announcement and two dialogs will be created in the final call state one from UE-A to the AS-hA1 and one from the AS-hA1 to the terminating UE which allows end-to-end communication.

9. MRFC-MRFP interaction.

The MRFC interacts with the MRFP in order to reserve resources for the announcement. As part of the interaction with MRFP the AS-hA1 receives the necessary media parameters e.g. IP address and port numbers and provide the IP address and port number for the calling party to the MRFP.

10-15. 183 (Session Progress) response (AS-hA1 to UE-A via S-CSCF-hA1, IBCF-hA1, IC-A1, IBCF-vA1 and P-CSCF-vA1)).

The AS-hA1 sends a 183 (Session progress) response to the S-CSCF-hA1. The response includes:

- a) an answer to the SDP received in the INVITE request;

NOTE 4: The AS-hA1 will include in the 183 (Session progress) response the Require header field with the option-tag "100rel" to indicate reliable sending of the 183 (Session Progress) response. If precondition mechanism is used, the AS-hA1 will include in the SDP answer an indication that the related local preconditions for QoS are fulfilled and will include in the Require header field the option-tag "precondition" to indicate the usage of the precondition mechanism.

- b) a P-Early-Media header field set to "sendonly" in case where only announcement will be played. For invoking an interactive voice response system a P-Early-Media header field is set to "sendrecv"; and
- c) the Require header field set to "100rel".

NOTE 5: If the interconnection network is SIP-unaware, step 13 is skipped.

16. PRACK request / 200 (OK) response to the PRACK request (UE-A to AS-hA1 / AS-hA1 to UE-A).

NOTE 6: If precondition mechanism is used and the UE-A indicated in the initial SDP offer the related local preconditions for QoS as not met the UE-A will include in the SDP offer sent within the PRACK request an indication that the local preconditions for QoS are fulfilled. Otherwise, if local preconditions for QoS are not fulfilled when sending the PRACK request, the UE-A will use the UPDATE request to send the SDP offer indicating that the local preconditions for QoS are fulfilled, but that case is outside the scope of the present example.

17. MRFC-MRFP interaction to start the announcement.

The MRFC interacts with the MRFP in order to start the announcement.

18. Announcement sending (MRFP-hA to UE-A).

The MRFP sends the announcement towards the calling party.

19. MRFC-MRFP interaction to stop the announcement.

The complete announcement is sent and the MRFP interacts with the AS-hA1/MRFC in order to inform that the announcement is terminated.

20. MRFC-MRFP interaction to release the resources used for the announcement.

The MRFC interacts with the MRFP in order to release the resources used for the announcement.

21-26. 199 (Early Dialog Terminated) response (AS-hA1 to UE-A via S-CSCF-hA1, IBCF-hA1, IC-A1, IBCF-vA1 and P-CSCF-vA1) (optional).

If the originating UE-A has indicated support of the 199 (Early Dialog Terminated) response code, the AS-hA1 sends a 199 (Early Dialog Terminated) provisional response towards the originating UE-A to terminate the early dialog between itself and the UE-A.

NOTE 7: If the interconnection network is SIP-unaware, step 24 is skipped.

27. INVITE request (AS-hA1 to S-CSCF-hA1).

The AS-hA1 sends the INVITE request towards the S-CSCF-hA1. The INVITE request contains the same information as the INVITE request shown in table 5.3.2.-7, see step 7 in clause 5.3.2.

28. INVITE request (S-CSCF-hA1 to IC-T1).

The S-CSCF-hA1 decides not to loopback the INVITE request and forwards the call to the remote network.

29. 180 (Ringing) response / 200 (OK) response to the INVITE request / ACK request (IC-T1 to UE-A via S-CSCF-hA1, AS-hA1, S-CSCF-hA1, IBCF-hA1, IC-A1, IBCF-vA1 and P-CSCF-vA1).

When the UE-A of the calling party receives the 200 (OK) response to the INVITE request and optional steps 21- 26 were not performed, the UE can regard the early dialog created for the announcement between the UE-A and the AS-hA1 as terminated. The UE-A sends the ACK request to acknowledge the reception of the 200 (OK) final response to the INVITE request.

5.11 PS to CS SRVCC access transfer scenarios

5.11.1 General

This clause describes PS to CS SRVCC access transfer scenarios including the registration and the additional message flow due to PS to CS SRVCC.

For IMS roaming PS to CS SRVCC procedure with media anchoring in the ATGW of the visited network and signalling anchored in the SCC AS of the home network is used.

In case of PS to CS SRVCC the media path between the visited network and the home network needs to be re-established since the SIP dialogue between the ATCF in the visited network and the SCC AS in the home network is re-established.

From viewpoint of the remote side the signalling anchors do not change due to the PS to CS SRVCC. However, the media anchors changes due to the PS to CS SRVCC in case of "originating roaming to home network without loopback" (see clause 5.3) since the CS target access leg is created using a new IBCF.

From the viewpoint of the IC network between the visited network and the home network this results in release of one connection and establishment of other connection, whereby the IC network is not aware about any link between these two connections. However, if the same IC network is used charging correlation can be done by means of the "related-icid" header field parameter in the P-Charging-Vector header field.

The 3GPP TS 24.237 [20] defines two types of MSC servers. One MSC server enhanced for ICS and another MSC server enhanced for SIP supporting PS to CS SRVCC. The message flows are the same if PS to CS SRVCC occurs so in the following subclauses both variants of MSC servers are referred to as "MSC server". The only difference between the two types is that when the MSC server is enhanced for ICS, the MSC server will register the user following the procedures in clause 5.2 when the PS to CS SRVCC access transfer procedure is completed.

NOTE: Once the user is registered by the MSC server, calls initiated by the UE will look the same as described in clause 5.3 and clause 5.4.

5.11.2 PS to CS SRVCC information transfer during registration

This clause describes the PS to CS SRVCC access transfer specifics during registration.

Preconditions to this flow are:

- the conditions in clause 5.2.2 are fulfilled; and

- both the visited network support PS to CS access transfer and MSC servers in the network are enhanced to use SIP signalling towards the IMS.

Figure 5.11.2-1 shows the message flow when a UE registers in IMS over PS before SRVCC occurs as described in clause 5.11.3.

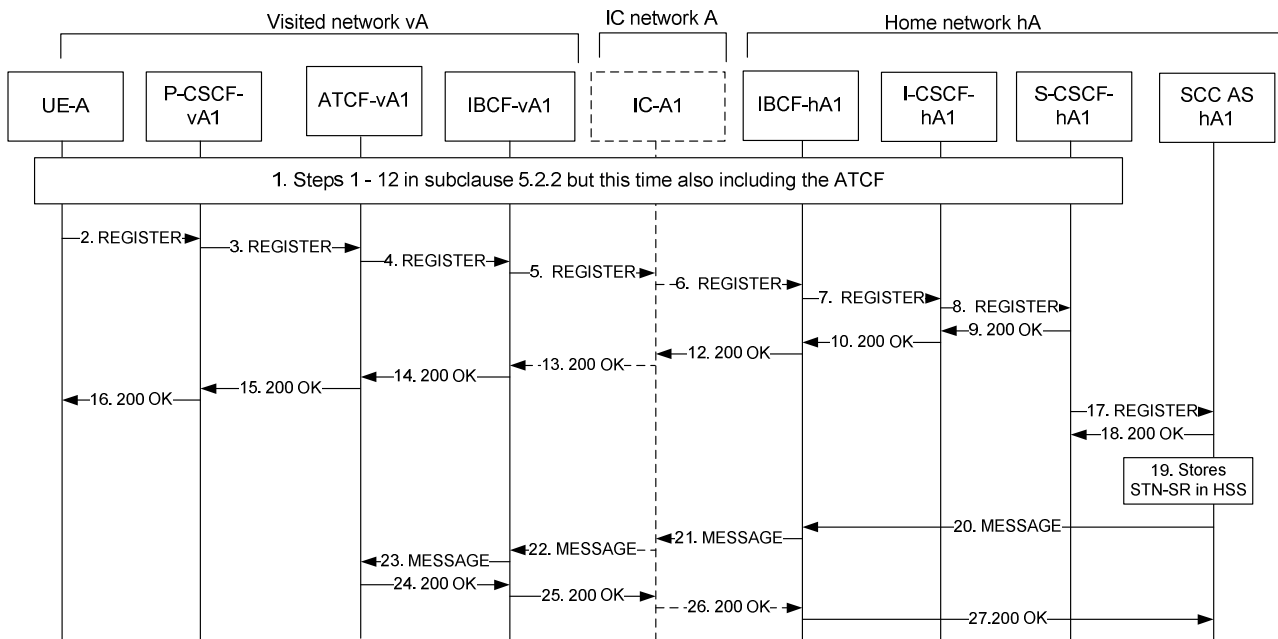

Figure 5.11.2-1: SRVCC information transfer during registration

The steps of the flow are as follows:

1. The UE-A registers in IMS and receives a 401 (Unauthorized) response.

The flow is the same as in clause 5.2.2 with the exception that the ATCF is included in the registration path.

2. REGISTER request (UE-A to P-CSCF-vA1) - see example in table 5.11.2-2.

The UE-A sends a REGISTER request again (now with an authentication challenge response included) as described clause 5.2.2.

Table 5.11.2-2: REGISTER request (UE-A to P-CSCF-vA1)

```
REGISTER sip:home-A.net SIP/2.0

From: <sip:userA_public1@home-A.net>;tag=4fa3
To: <sip:userA_public1@home-A.net>
P-Access-Network-Info: 3GPP-E-UTRAN-TDD;utran-cell-id-3gpp=234151D0FCE11
Supported: path
Contact: <sip:[5555::aaa:bbb:ccc:ddd]>;reg-id=1;+sip.instance="<urn:gsma:imei:90420156-025763-0>;expires=600000;+g.3gpp.ics="principal";+g.3gpp.accesstype="cellular1"
CSeq: 10 REGISTER

Via:SIP/2.0/UDP [5555::aaa:bbb:ccc:ddd];branch=z9hG4bKnashds7

Other SIP header fields are set according to 3GPP TS 24.229 [4] and 3GPP TS 24.237 [20].
```

- Request-URI:** The Request-URI sip:home-A.net (the URI that follows the method name, "REGISTER", in the first line) indicates the destination domain of this REGISTER request which is the home network.
- From:** Set to the SIP URI that is the default public user identity of the user A i.e. userA_public1@home-A.net.
- To:** Set to the SIP URI that is the default public user identity of the user A i.e. userA_public1@home-A.net.
- Supported:** The UE-A inserts the Supported header field containing the option-tag "path".

3. REGISTER request (P-CSCF-vA1 to ATCF-vA1) - see example in table 5.11.2-3.

When the P-CSCF-vA1 receives the REGISTER request, the P-CSCF-vA1 forwards the REGISTER request to an ATCF-vA1 according to local policy. The content of the REGISTER request is not different from the content of the REGISTER request in clause 5.2.2.

Table 5.11.2-3: REGISTER request (P-CSCF-vA1 to ATCF-vA1)

```
REGISTER sip:home-A.net SIP/2.0

From:
To:
P-Access-Network-Info: 3GPP-E-UTRAN-TDD;utran-cell-id-3gpp=234151D0FCE11,3GPP-E-UTRAN-TDD; utran-
cell-id-3gpp=234151D0FCE11;network-provided;local-time-zone="UTC+01:00";daylight-saving-time="01"
Supported:
Contact:
CSeq:
Require: path
Route: <sip:atcf-vA1.visited-A.net;lr>
Path: <sip:visit-xyz@pcscf-vA1.visited-A.net:5070;lr;iotl=homeB-visitedB>
P-Visited-Network-ID: "Visited Network Number A"
P-Charging-Vector: icid-value="AyretyU0dm+602IrT5tAFrbHLso=023551024";orig-ioi="Type 1visited-a"

Via:SIP/2.0/UDP pcscf-vA1.visited-A.net:5060;branch=z9hG4bKnas56565
Via:SIP/2.0/UDP [5555::aaa:bbb:ccc:ddd];branch=z9hG4bKnashds7

Other SIP header fields are set according to 3GPP TS 24.229 [4].
```

P-Access-Network-Info: The P-CSCF-vA1 adds the network provided location including the "local-time-zone" and "daylight saving time" header field parameters. The location information received from the UE-A is kept since it does not indicate that it is network provided.

Require: The P-CSCF-vA1 adds the Require header field containing the option-tag "path" to ensure that the recipient correctly handles the Path header field. If the recipient does not support the Path header field, a SIP response will be received with a status code of 420 and an Unsupported header field indicating the option-tag "path". Such a response indicates a wrong configuration of the routing tables and the request has been routed outside the IM CN subsystem.

Route: The P-CSCF-vA1 adds the Route header field with the address of the ATCF-vA1.

Path: This is the address of the P-CSCF-vA1 and is included to inform the S-CSCF where to route terminating requests. The Path header field includes traffic leg information in the iotl SIP URI parameter according to IETF RFC 7549 [26].

P-Visited-Network-ID: The P-CSCF-vA1 adds the P-Visited-Network-ID header field containing the identifier of the P-CSCF network. This may be the visited network domain name or any other identifier that identifies the visited network at the home network.

Via: The P-CSCF-vA1 adds a Via header field in the REGISTER request.

P-Charging-Vector: The P-CSCF-vA1 provides an ICID value and adds a type 1 "orig-ioi" header field parameter with the IOI value identifying the visited network (i.e. "visited-a").

4. REGISTER request (ATCF-vA1 to IBCF-vA1) - see example in table 5.11.2-4.

When the ATCF-vA1 receives the REGISTER request, the ATCF-vA1 updates its database for registrations and selects an IBCF according to local policy for routeing the REGISTER request towards the home network.

Table 5.11.2-4: REGISTER request (ATCF-vA1 to IBCF-vA1)

```
REGISTER sip:home-A.net SIP/2.0

From:
To:
P-Access-Network-Info:
Supported:
Contact:
CSeq:
Require:
Route: <sip:ibcf-vA1.visited-A.net;lr>
```

```

Path: <sip:atcf-vA1.visited-A.net;lr>,<sip:visit-xyz@pcscf-vA1.visited-A.net:5070;lr;iotl=homeB-visitedB>
P-Visited-Network-ID:
P-Charging-Vector:
Feature-Caps: *;+g.3gpp.atcf="<tel:+1-237-555-3333>";+g.3gpp.atcf-mgmt-uri="<sip:atcf-vA1.visited-A.net;iotl=homeB-visitedB>";+g.3gpp.atcf-path="<sip:termabc@atcf-vA1.visited-A.net>";+g.3gpp.mid-call;+g.3gpp.srvcc-alerting;+g.3gpp.ps2cs-srvcc-orig-pre-alerting

Via:SIP/2.0/UDP atcf-vA1.visited-A.net:5060;branch=z9hG4bKaa3689b
Via:SIP/2.0/UDP pcscf-vA1.visited-A.net:5060;branch=z9hG4bKnas56565
Via:SIP/2.0/UDP [5555::aaa:bbb:ccc:ddd];branch=z9hG4bKnashds7

Other SIP header fields are set according to 3GPP TS 24.229 [4] and 3GPP TS 24.237 [20].

```

Route: The ATCF-vA1 adds the Route header field identifying the selected IBCF-vA1.

Path: The ATCF-vA1 adds its address for terminating requests in the Path header field.

Feature-Caps: The ATCF-vA1 adds a number of feature-capability indicators in the Feature-Caps header field.

- The g.3gpp.atcf capability-indicator includes the STN-SR that will be used during PS to CS access transfer by the MSC server.
- The g.3gpp.atcf-mgmt-uri feature-capability indicator includes the URI that will be used by the SCC AS when sending the MESSAGE request with the PS to CS SRVCC information to the ATCF-vA1 The URI includes an "iotl" SIP URI parameter according to IETF RFC 7549 [26].
- The g.3gpp.atcf-path feature-capability indicator is used by ATCF to identify the registration in its database for registrations and will be included by SCC AS in the MESSAGE request with the PS to CS SRVCC information sent to the ATCF-vA1.
- The g.3gpp.mid-call, g.3gpp.srvcc-alerting and g.3gpp.ps2cs-srvcc-orig-pre-alerting feature-capability indicators are included to indicate which PS to CS SRVCC features the visited network supports.

Via: The ATCF-vA1 adds a Via header field in the REGISTER request.

5-8. REGISTER request (IBCF-vA1 to S-CSCF-hA1 via IC-A1, IBCF-hA1 and I-CSCF-hA1) - see example in table 5.11.2-8.

When the IBCF-vA1 receives the REGISTER request, the IBCF-vA1 forwards the REGISTER request in the same way as in clause 5.2.2. There is no more SRVCC specific information added in the REGISTER request.

The table 5.11.2-8 shows the content of the REGISTER request when received in the S-CSCF-hA1.

Table 5.11.2-8: REGISTER request (I-CSCF-hA1 to S-CSCF-hA1) in step 8

```

REGISTER sip:home-A.net SIP/2.0

From:
To:
P-Access-Network-Info:
Supported:
Contact:
CSeq:
Require:
Route: <sip:scscf-hA1.home-A.net;lr>
Path: <sip:home-abc@ibcf-hA1.home-A.net:5070;lr>,<sip:proxy-abc@ic-A1.interconnection-A.net:5070;lr>,<sip:visit-abc@ibcf-vA1.visited-A.net:5070;lr>,<sip:atcf-vA1.visited-A.net;lr>,<sip:visit-xyz@pcscf-vA1.visited-A.net:5070;lr;iotl=homeB-visitedB>
P-Visited-Network-ID:
P-Charging-Vector: icid-value="AyretyU0dm+6O2IrT5tAFrbHLso=023551024";orig-ioi="Type 1visited-a";transit-ioi="ICa.1"
Feature-Caps:

Via:SIP/2.0/UDP icscf-hA1.home-A.net;branch=z9hG4bK351g45.3
Via:SIP/2.0/UDP ibcf-hA1.home-A.net;branch=z9hG4bK351g45.2
Via:SIP/2.0/UDP ic-A1.interconnection-A.net;branch=z9hG4bK78a3z
Via:SIP/2.0/UDP ibcf-vA1.visited-A.net;branch=z9hG4bK351g45.1
Via:SIP/2.0/UDP atcf-vA1.visited-A.net:5060;branch=z9hG4bKaa3689b
Via:SIP/2.0/UDP pcscf-vA1.visited-A.net:5060;branch=z9hG4bKnas56565
Via:SIP/2.0/UDP [5555::aaa:bbb:ccc:ddd];branch=z9hG4bKnashds7

```

Other SIP header fields are set according to 3GPP TS 24.229 [4].
--

- Path:** The address of the IBCF-vA1 acting as an exit point added by the IBCF-vA1.
Based on SLA between IC partners and roaming partners the address of the IC-A1 added by IC-A1.
The address of the IBCF-hA1 acting as an entry point added by the IBCF-hA1.
- Route:** The I-CSCF-hA1 adds the address of the selected S-CSCF.
- Via:** The IBCF-vA1 added a Via header field.
The IC-A1 added a Via header field.
The IBCF-hA1 added a Via header field.
The I-CSCF-vA1 added a Via header field.
- P-Charging-Vector:** The "transit-ioi" header field parameter with an IOI value identifying the transit network (i.e. "ICa") added by IC-A1.

NOTE 1: If the interconnection network is SIP-unaware, step 6 is skipped.

9-16. 200 (OK) response (S-CSCF-hA1 to UE-A).

The S-CSCF-hA1 acknowledges the REGISTER request by means of a 200 (OK) response as described in clause 5.2.2. The 200 (OK) response does not contain any SRVCC specific information more than that the ATCF-vA1 is included in the Path header field and in the Via header field.

NOTE 2: If the interconnection network is SIP-unaware, step 13 is skipped.

17. REGISTER request (S-CSCF-hA1 to SCC AS-hA1) - see example in table 5.11.2-17.

The S-CSCF-hA1 checks the iFC triggers and detects that the SCC AS-hA1 is interested in registrations from this user. The S-CSCF-hA1 sends a 3rd party REGISTER request to the SCC AS-hA1. The S-CSCF-hA1 includes in the 3rd party REGISTER request the contents of the initial REGISTER request and the 200 (OK) response to the initial REGISTER request in "sip" message bodies.

Table 5.11.2-17: REGISTER request (S-CSCF-hA1 to SCC AS-hA1)

```
REGISTER sip:sccas.home-A.net /2.0

To: <sip:userA_public1@home-A.net>
From: <sip:scscf-hA1.home-A.net>; tag=538ya
Contact: <sip:scscf-hA1.home-A.net>; expires=600000
CSeq: 10 REGISTER
P-Charging-Vector: icid-value="AyretyU0dm+602IrT5tAFrbHLso=023551024";orig-ioi="Type 3home-a"

Via: SIP/2.0/TCP scscf-hA1.home-A.net;branch=z9hG499ffhy

Content-Type: multipart/mixed;boundary="boundary1"
Content-Length: (...)

--boundary1
Content-Type: message/sip

REGISTER sip:home-A.net SIP/2.0
From: <sip:userA_public1@home-A.net>;tag=4fa3
To: <sip:userA_public1@home-A.net>
P-Access-Network-Info: 3GPP-E-UTRAN-TDD;utran-cell-id-3gpp=234151D0FCE11,3GPP-E-UTRAN-TDD; utran-cell-id-3gpp=234151D0FCE11;network-provided;local-time-zone="UTC+01:00";daylight-saving-time="01"
Supported: path
Contact: <sip:[5555::aaa:bbb:ccc:ddd]>;reg-id=1;+sip.instance="urn:gsma:imei:90420156-025763-0";expires=600000;+g.3gpp.ics="principal";+g.3gpp.accesstype="cellular1"
CSeq: 12 REGISTER
Require: path
Path: <sip:home-abc@ibcf-hA1.home-A.net:5070;lr>,
      <sip:proxy-abc@ic-A1.interconnection-A.net:5070;lr>,
      <sip:visit-abc@ibcf-vA1.visited-A.net:5070;lr>,
      <sip:atcf-vA1.visited-A.net;lr>,
      <sip:visit-xyz@pcscf-vA1.visited-A.net:5070;lr;iotl=homeB-visitedB>
P-Visited-Network-ID: "Visited Network Number A"
P-Charging-Vector: icid-value="AyretyU0dm+602IrT5tAFrbHLso=023551024";orig-ioi="Type 1visited-a";transit-ioi="ICa.1"
```

```

Feature-Caps:*;+g.3gpp.atcf="<tel:+1-237-555-3333>";+g.3gpp.atcf-mgmt-uri="<sip:atcf-vA1.visited-A.net;iotl=homeB-visitedB>";+g.3gpp.atcf-path="<sip:termabc@atcf-vA1.visited-A.net>";+g.3gpp.mid-call;+g.3gpp.srvcc-alerting;+g.3gpp.ps2cs-srvcc-orig-pre-alerting

Via:SIP/2.0/UDP icscf-hA1.home-A.net;branch=z9hG4bK351g45.3
Via:SIP/2.0/UDP ibcf-hA1.home-A.net;branch=z9hG4bK351g45.2
Via:SIP/2.0/UDP ic-A1.interconnection-A.net;branch=z9hG4bK78a3z
Via:SIP/2.0/UDP ibcf-vA1.visited-A.net;branch=z9hG4bK351g45.1
Via:SIP/2.0/UDP atcf-vA1.visited-A.net:5060;branch=z9hG4bKaa3689b
Via:SIP/2.0/UDP pcsf-vA1.visited-A.net:5060;branch=z9hG4bKnas56565
Via:SIP/2.0/UDP [5555::aaa:bbb:ccc:ddd];branch=z9hG4bKdashds7

--boundary1
Content-Type: message/sip

SIP/2.0 200 OK
From: <sip:userA_public1@home-A.net>;tag=4fa3
To: <sip:userA_public1@home-A.net>;tag=5ef4
CSeq: 10 REGISTER
P-Associated-URI: <sip:userA_public1@home-A.net>, <tel:+1-237-555-1111>
Contact: <sip:[5555::aaa:bbb:ccc:ddd]>;reg-id=1;+sip.instance="<urn:gsma:imei:90420156-025763-0>";expires=600000;+g.3gpp.ics="principal";+g.3gpp.accesstype="cellular1"
Service-Route: <sip:home-abc@s-cscf-hA1.home-A.net;lr;iotl=visitedA-homeA>
P-Charging-Vector: icid-value="AyretyU0dm+602IrT5tAFrBHLSo=023551024";orig-ioi="Type 1visited-a";term-ioi="Type 1home-a"
Relayed-Charge: SCSCF:transit-ioi="ICa.1"
Path: <sip:home-abc@ibcf-hA1.home-A.net:5070;lr>,
      <sip:proxy-abc@ic-A1.interconnection-A.net:5070;lr>,
      <sip:visit-abc@ibcf-vA1.visited-A.net:5070;lr>,
      <sip:atcf-vA1.visited-A.net;lr>,<sip:visit-xyz@pcsf-vA1.visited-A.net:5070;lr;iotl=homeB-visitedB>

Via:SIP/2.0/UDP icscf-hA1.home-A.net;branch=z9hG4bK351g45.3
Via:SIP/2.0/UDP ibcf-hA1.home-A.net;branch=z9hG4bK351g45.2
Via:SIP/2.0/UDP ic-A1.interconnection-A.net;branch=z9hG4bK78a3z
Via:SIP/2.0/UDP ibcf-vA1.visited-A.net;branch=z9hG4bK351g45.1
Via:SIP/2.0/UDP atcf-vA1.visited-A.net:5060;branch=z9hG4bKaa3689b
Via:SIP/2.0/UDP pcsf-vA1.visited-A.net:5060;branch=z9hG4bKnas56565
Via:SIP/2.0/UDP [5555::aaa:bbb:ccc:ddd];branch=z9hG4bKdashds7
--boundary1-
Other SIP header fields are set according to 3GPP TS 24.229 [4].

```

P-Charging-Vector: The S-CSCF-hA1 inserts the "orig-ioi" header field parameter with a type 3 IOI value identifying the home network hA.

Relayed-Charge: The S-CSCF adds the Relayed-Charge header field set to the value received in the "transit-ioi" header field in the P-Charging-Vector. The S-CSCF is set as the source.

Via: The S-CSCF-hA1 adds a Via header field.

18. 200 (OK) response (SCC AS-hA1 to S-CSCF-hA1).

The SCC AS-hA1 acknowledges the REGISTER request by means of a 200 (OK) response. There is no specific SRVCC access transfer information added by SCC AS-hA1 in the 200 (OK) response.

19. The SCC AS-hA1 stores the STN-SR in HSS.

The SCC AS-hA1 stores the STN-SR (<tel:+1-237-555-3333>) received in the "+g.3gpp.atcf" Feature-Caps header field parameter in HSS. This information will later be transferred to the MSC server when a PS to CS SRVCC access transfer occurs as described in clause 5.11.3.

20. MESSAGE request (SCC AS-hA1 to IBCF-hA1) - see example in table 5.11.2-20.

In order to inform about PS to CS SRVCC access transfer parameters necessary for the ATCF-vA1 during PS to CS SRVCC access transfer, the SCC AS-hA1 sends a MESSAGE request to the IBCF-hA1.

Table 5.11.2-20: MESSAGE request (SCC AS-hA1 to IBCF-hA1)

```

MESSAGE sip:atcf-vA1.visited-A.net;iotl=homeB-visitedB SIP/2.0

From: <sip:sccas-hA1.home-A.net>;tag=123e5
To: <sip:atcf-vA1.visited-A.net>
Cseq: 100 MESSAGE

```

```
P-Asserted-Identity: <sip:sccas-hA1.home-A.net>
P-Charging-Vector: icid-value="BrTA76543y+403fg654tBf456fa=023551024";orig-ioi="Type 1home-a"
Content-Length: (...)
Content-Type: application/vnd.3gpp.SRVCC-info+xml
Route: <sip:ibcf-hA1.home-A.net>
```

```
Via: SIP/2.0/UDP sccas-hA1.home-A.net:5060;branch=z9hG4bK78956a
```

```
<?xml version="1.0" encoding="UTF-8"?>
<SRVCC-infos>
  <SRVCC-info ATCF-Path-URI="sip:termabc@atcf-vA1.visited-A.net">
    <ATU-STI>sip:sccas-hA1.home-A.net;iotl=visitedA-homeA</ATU-STI>
    <C-MSISDN>tel:+1-237-555-1111</C-MSISDN>
  </SRVCC-info>
</SRVCC-infos>
```

Other SIP header fields are set according to 3GPP TS 24.229 [4] and 3GPP TS 24.237 [20].

Request-URI/To: Contains the address received in the g.3gpp.atcf-mgmt-uri feature-capability indicator, including traffic leg information in an "iotl" SIP URI parameter according to IETF RFC 7549 [26].

P-Asserted-Identity/From: Includes the SCC AS-hA1 address.

P-Charging-Vector: The SCC AS-hA1 assigns a new ICID value and includes a type 1 IOI value in the "orig-ioi" header field parameter. The type IOI value identifies the home network hA.

Via: The SCC AS-hA1 adds a Via header field.

application/vnd.3gpp.SRVCC-info+xml: Contains the PS to CS SRVCC specific information that will be used by the ATCF-vA1 when SRVCC occurs as described in clause 5.11.3.

- The SRVCC-info ATCF-Path-URI identifies the registration in the ATCF-vA1.
- The ATU-STI is the address of the SCC AS where the INVITE request will be sent to in the event of a PS to CS SRVCC access transfer. The ATU-STI includes traffic leg information in an "iotl" SIP URI parameter according to IETF RFC 7549 [26].
- C-MSISDN is the public user identity of the user that the ATCF-vA1 is using to identify the user in the event of a PS to CS SRVCC access transfer.

21. MESSAGE request (IBCF-hA1 to IC-A1) - see example in table 5.11.2-21.

The IBCF-hA1 selects to route the MESSAGE request via an IC network and sends the MESSAGE request according to 3GPP TS 24.229 [4] to the IC-A1. The IBCF-hA1 determines the next hop IP address from the request URI either by configured information or using a DNS query according to IETF RFC 3263 [13]. If the subsequent interconnection network is SIP-aware, the determined IP address will belong to the SIP proxy IC-A1. Otherwise the determined IP address will point to IBCF-vA1 and step 22 is skipped (not reflected in message details below).

Table 5.11.2-21: MESSAGE request (IBCF-hA1 to IC-A1)

```
MESSAGE sip:atcf-vA1.visited-A.net;iotl=homeB-visitedB SIP/2.0

From:
P-Asserted-Identity:
To:
CSeq:
P-Charging-Vector:
Content-Length:
Content-Type:
Route: <sip:ic-A1.interconnection-A.net>

Via:SIP/2.0/UDP ibcf-hA1.home-A.net:5060;branch=z9hG4bK123456
Via:SIP/2.0/UDP sccas-hA1.home-A.net:5060;branch=z9hG4bK78956a

<?xml version="1.0" encoding="UTF-8"?>
<SRVCC-infos>
  <SRVCC-info ATCF-Path-URI="sip:termabc@atcf-vA1.visited-A.net">
    <ATU-STI>sip:sccas-hA1.home-A.net</ATU-STI>
    <C-MSISDN>tel:+1-237-555-1111</C-MSISDN>
  </SRVCC-info>
```

```
</SRVCC-infos>
```

Other SIP header fields are set according to 3GPP TS 24.229 [4].

Route: The IBCF-hA1 adds a Route header field identifying the selected node in the IC network A.

Via: The IBCF-hA1 adds a Via header field.

22. MESSAGE request (IC-A1 to IBCF-vA1) - see example in table 5.11.2-22.

The IC-A1 selects an IBCF acting as the entry point in the visited network vA and sends the MESSAGE request according to 3GPP TS 24.229 [4] to the IBCF-vA1.

NOTE 3: If the interconnection network is SIP-unaware, step 22 is skipped.

Table 5.11.2-22: MESSAGE request (IC-A1 to IBCF-vA1)

```
MESSAGE sip:atcf-vA1.visited-A.net;iotl=homeB-visitedB SIP/2.0
```

```
From:
P-Asserted-Identity:
To:
CSeq:
P-Charging-Vector: icid-value="Brta76543y+403fg654tBf456fa=023551024";orig-ioi="Type lhome-
a";transit-ioi="ICa.1"
Content-Length: ...
Content-Type:
Route: <sip:ibcf-vA1.visited-A.net>
```

```
Via:SIP/2.0/UDP ic-A1.interconnection-A.net:5060;branch=z9hG4bKasdfg
Via:SIP/2.0/UDP ibcf-hA1.home-A.net:5060;branch=z9hG4bK123456
Via:SIP/2.0/UDP sccas-hA1.home-A.net:5060;branch=z9hG4bK78956a
```

```
<?xml version="1.0" encoding="UTF-8"?>
<SRVCC-infos>
  <SRVCC-info ATCF-Path-URI="sip:termabc@atcf-vA1.visited-A.net">
    <ATU-STI>sip:sccas-hA1.home-A.net;iotl=visitedA-homeA</ATU-STI>
    <C-MSISDN>tel:+1-237-555-1111</C-MSISDN>
  </SRVCC-info>
</SRVCC-infos>
```

Other SIP header fields are set according to 3GPP TS 24.229 [4].

P-Charging-Vector: The IC-A1 adds the "transit-ioi" header field parameter with an IOI value identifying the transit network (i.e. "ICa").

Route The IC-A1 adds a Route header field identifying the selected entry point in the visited network vA.

Via: The IC-A1 adds a Via header field.

23. MESSAGE request (IBCF-vA1 to ATCF-vA1) - see example in table 5.11.2-23.

When the IBCF-vA1 receives the MESSAGE request, the IBCF-vA1 retrieves the address of the ATCF-vA1 (e.g. by performing a DNS query or using a local database) and forwards the MESSAGE request to the ATCF-vA1.

In this example, the IBCF-vA1 does not add any "transit-ioi" header field parameter in the P-Charging-Vector header field. However, the IBCF-vA1 adds the "transit-ioi" header field parameter based on local policy, when the "transit-ioi" identifying the preceding interconnection network is not included in the received request (e.g. when the preceding interconnection network is not an IMS transit network).

Table 5.11.2-23: MESSAGE request (IBCF-vA1 to ATCF-vA1)

```
MESSAGE sip:atcf-vA1.visited-A.net;iotl=homeB-visitedB SIP/2.0
```

```
From:
P-Asserted-Identity:
To:
CSeq:
P-Charging-Vector:
Content-Length: ...
```

```
Content-Type:

Via:SIP/2.0/UDP ibcf-vA1.visited-A.net:5060;branch=z9hG4bKlkjhg12
Via:SIP/2.0/UDP ic-A1.interconnection-A.net:5060;branch=z9hG4bKasdfg
Via:SIP/2.0/UDP ibcf-hA1.home-A.net:5060;branch=z9hG4bK123456
Via:SIP/2.0/UDP sccas-hA1.home-A.net:5060;branch=z9hG4bK78956a

<?xml version="1.0" encoding="UTF-8"?>
<SRVCC-infos>
  <SRVCC-info ATCF-Path-URI=<"sip:termabc@atcf-vA1.visited-A.net">
    <ATU-STI>sip:sccas-hA1.home-A.net;iotl=visitedA-homeA</ATU-STI>
    <C-MSISDN>tel:+1-237-555-1111</C-MSISDN>
  </SRVCC-info>
</SRVCC-infos>

Other SIP header fields are set according to 3GPP TS 24.229 [4].
```

Via: The IBCF-vA1 adds a Via header field.

24-27. 200 (OK) response (ATCF-vA1 to SCC AS-hA1 via IBCF-vA1, IC-A1 and IBCF-hA1) - see example in table 5.11.2-27.

The ATCF-vA1 acknowledges the receipt of the MESSAGE request by means of a 200 (OK) response according to 3GPP TS 24.229 [4]. No SRVCC specific parameters are included in the 200 (OK) response.

The table 5.11.2-27 shows the content of the 200 (OK) response when received in the SCC AS-hA1.

Table 5.11.2-27: 200 (OK) response (IBCF-hA1 to SCC AS-hA1) in step 27

```
SIP/2.0 200 OK

P-Charging-Vector: icid-value="BrTA76543y+403fg654tBf456fa=023551024";orig-ioi="Type 1home-a";term-
ioi="Type 1visited-a"; transit-ioi="ICa.1"
From: <sip:sccas-hA1.home-A.net>;tag=123e5
To: <sip:atcf-vA1.visited-A.net>;tag=678f9
CSeq: 100 MESSAGE

Via: SIP/2.0/UDP sccas-hA1.home-A.net:5060;branch=z9hG4bK78956a

Other SIP header fields are set according to 3GPP TS 24.229 [4] and 3GPP TS 24.237 [20].
```

P-Charging-Vector: The ATCF-vA1 added a P-Charging-Vector header field with the same "icid-value" and the same "orig-ioi" header field parameter value as received in the MESSAGE request and a type 1 IOI value in a "term-ioi" header field parameter identifying the visited network vA.

The IC-A1 added the "transit-ioi" header field parameter with an IOI value identifying the transit network (i.e. "ICa").

NOTE 4: If the interconnection network is SIP-unaware, step 26 is skipped.

5.11.3 PS to CS SRVCC access transfer for a call in the active phase without loopback

This clause describes the PS to CS SRVCC access transfer of a call in the active phase.

Preconditions to this call flow:

1. a call is established between a UE-A and a remote UE as described in clause 5.3. The UE-A is attached to a 4G radio access network (E-UTRAN);
2. media is anchored in:
 - a. the P-CSCF-vA1, the ATCF-vA1 and IBCF-vA1 in the visited network vA;
 - b. the IC-A1 in the IC network A; and
 - c. the IBCF-hA1 and the IBCF-hA2 in the home network hA; and
3. SIP signalling is anchored in SCC AS-hA1.

NOTE 1: The signalling flow is the same for PS to CS SRVCC access transfer for a call in the active phase regardless if the UE-A or the remote UE initiated the call.

Figure 5.11.3-1 shows the SIP message flow when PS to CS SRVCC access transfer of a call in the active phase occurs.

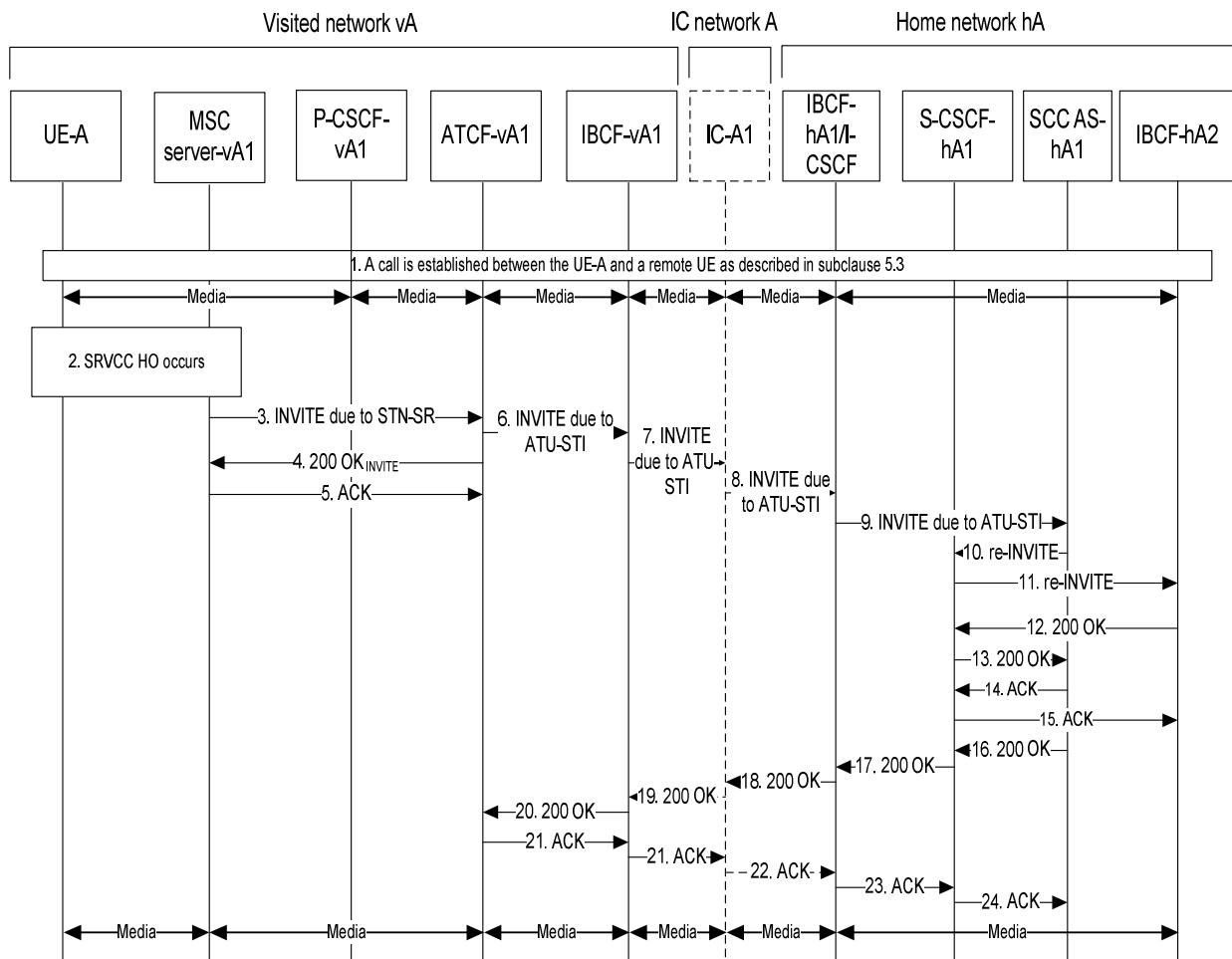

NOTE: For clarity, the SIP 100 (Trying) messages are not shown in the signalling flow.

Figure 5.11.3-1: SRVCC without loop back message flow

The steps of the flow are as follows:

1. A call is established as described in clause 5.3 between UE-A and a remote UE.

- The remote UE can be a UE connected to IMS or an UE connected to CS and the difference compared to the description in clause 5.3 and this PS to CS SRVCC access transfer scenario is that an ATCF in the visited originated network participated in the call establishment of the call and that the general AS-hA1 in figure 5.3.2-1 is replaced by the access transfer specific AS i.e. the SCC AS-hA1.
- The media path is UE-A – P-CSCF-vA1 – ATCF-vA1 – IBCF-vA1 – IC-A1 – IBCF-hA1 – IBCF-hA2 – remote network – remote UE.

NOTE 2: If the interconnection network is SIP-unaware, or if IC-A1 is only a SIP proxy rather than a SIP-ALG with attached SIP-AGW, IC-A1 is not in the media path.

2. SRVCC handover occurs.

During the ongoing call the UE-A is performing measurements on signalling strength in neighbouring cells and sends continuously the measurement results to the core network. Due to decreasing signalling strength in the 4G radio access network the core network takes a decision that the UE shall be handed over to a 3G radio access network and sends a PS to CS SRVCC request to the MSC server-vA1.

3. INVITE request due to STN-SR (MSC server-vA1 to ATCF-vA1) - see example in table 5.11.3-3.

- When the MSC server-vA1 receives the PS to CS SRVCC request from the core network in the visited network, the MSC server-vA1 sends an INVITE request to the ATCF-vA1. This INVITE request is referred to as an "INVITE request due to STN-SR" in the 3GPP TS 24.237 [20].

Table 5.11.3-3: INVITE request due to STN-SR (MSC server-vA1 to ATCF-vA1)

```
INVITE tel:+1-237-555-3333 SIP/2.0

From: <tel:+1-237-555-1111>;tag=171828
To: <tel:+1-237-555-3333>
P-Asserted-Identity: <tel:+1-237-555-1111>
P-Access-Network-Info: 3GPP-UTRAN-TDD;utran-cell-id-3gpp=151234D0EAF22;network-provided;local-time-zone="UTC+01:10";daylight-saving-time="01"
P-Charging-Vector: icid-value="023551024"; orig-ioi="Type 1visited-a";icid-generated-at="msc-vA1.visited-A.net"
Contact: <sip: msc-vA1.visited-A.net:1357>;+g.3gpp.icsi-ref="urn%3Aurn-7%3A3gpp-service.ims.icsi.mmtel";+g.3gpp.srvcc-alerting;+g.3gpp.mid-call;+ps2cs-srvss-orig-pre-alerting
CSeq: 11 INVITE
Accept: "application/vnd.3gpp.state-and-event-info+xml"
Recv-Info: g.3gpp.state-and-event
Supported:norefersub,100rel, precondition

Via:SIP/2.0/UDP msc-vA1.visited-A.net;branch=z9hG4bk7987fe

Other SIP header fields and SDP according to 3GPP TS 24.229 [4] and 3GPP TS 24.237 [20].
```

Request-URI/To: The tel URI (referred to as STN-SR) identifies the ATCF-vA1. The STN-SR is stored by SCC AS-hA1 in HSS during registration of the user as described in clause 5.11.2 and sent to the MSC server-vA1 in the PS to CS SRVCC request from the core network.

P-Access-Network-Info: This header field identifies the location of the UE in the 3G access network, the time-zone and daylight saving on that location.

P-Charging-Vector: The MSC server-vA1 adds the P-Charging-Vector header field containing a new ICID value in the "icid", "icid-generated-at" and "orig-ioi" header field parameters. The IOI value is of type 1 and identifies the visited network vA.

P-Asserted-Identity/From: The P-Asserted identity and the From header fields is the C-MSISDN and that is not necessary the same identity used in the original call. For example: In the original call the P-Asserted-Identity header field could be adam@homenetwork.net.

Contact: The Contact header field can, additional to the contact address, include a number of media feature tags. In this example the g.3gpp.icsi-ref indicates that this is an MMTel call, the g.3gpp.srvcc-alerting indicates that the MSC server-vA1 supports PS to CS access transfer for call in alerting phase, the g.3gpp.mid-call indicates that the MSC server-vA1 supports transfer of held calls and conference calls and the ps2cs-srvss-orig-pre-alerting indicates that the MSC server-vA1 supports PS to CS SRVCC access transfer for calls in the originating pre-alerting phase. The media-feature tags will be used by the SCC AS-vA1 to determine which sessions to be transferred.

Accept: The MSC server-vA1 adds an Accept header field containing the MIME type application/vnd.3gpp.state-and-event-info+xml.

Recv-Info: The MSC server-vA1 adds a Recv-Info header field containing the g.3gpp.state-and-event package name.

Supported: The MSC server indicates option tags to indicate supported feature.

4. 200 (OK) response (ATCF-vA1 to MSC server-vA1) – see example in table 5.11.3-4.

When the ATCF-vA1 receives the INVITE due to STN-SR the ATCF-vA1 checks if there is a session that fulfils conditions for being transferred and detects that there is a call in an active phase ongoing between UE-A and a remote UE. To avoid speech gaps, the ATCF-vA1 returns a 200 (OK) response towards the MSC server-vA1 containing media parameters retrieved from the ATGW.

The ATCF-vA1 also adds the "related-icid" header field parameter containing the "icid-value" header fields parameter used in the original call and can be used for charging correlation of generated CDR records in the visited network A (i.e. "visited-a").

Table 5.11.3-4: 200 (OK) response (ATCF-vA1 to MSC server-vA1)

```
SIP/2.0 200 OK

From: <tel:+12375551111>;tag=171828
To: <tel:+12375553333>;tag=271818
Record-Route: <sip:atcf-vA1.visited-A.net:5070;lr>
P-Charging-Vector: icid-value="023551024"; icid-generated-at="msc-vA1.visited-A.net"; orig-ioi="Type
lvisited-a"; term-ioi="Type lhome-a"; related-icid="AyretyU0dm+6O2Irt5tAFrbHLso=023551024"
Feature-Caps: *;+g.3gpp.srvcc-alerting,*;+g.3gpp.mid-call,*;+ps2cs-srvss-orig-pre-alerting
Contact: <sip:[5555::bbb:ccc:ddd:aaa]>
CSeq: 11 INVITE
P-Asserted-Identity: <tel:+4687197378>,<sip:+4687197378@home-R.net;user=phone>

Via: SIP/2.0/UDP msc-vA1.visited-A.net;branch=z9hG4bk7987fe

Other SIP header fields and SDP according to 3GPP TS 24.229 [4] and 3GPP TS 24.237 [20].
```

Record-Route: The ATCF adds its own address in the header field which will be used by the MSC server-vA1 for subsequent SIP requests.

P-Charging-Vector: The P-Charging-Vector contains the parameters received in the INVITE due to STN-SR and the related-icid header field parameter containing the ICID value received in the session to be transferred.

Editor's note: Whether the P-Charging-Vector shall contain term-ioi and/or transit-ioi or not is FFS. At the moment the term-ioi and transit-ioi is not currently specified in 3GPP TS 24.237 [20].

Feature-Caps: The feature-capability indicators as received on the home leg in the session to be transferred.

Contact: The contact address of the remote UE is included.

P-Asserted-Identity: The public user identity of the remote UE is included.

5. ACK request (MSC-vA1 to ATCF-vA1).

The MSC server-vA1 sends the ACK to the ATCF-vA1 according to 3GPP TS 24.229 [4]. The ACK request does not contain any SRVCC specific information.

6. INVITE request due to ATU-STI (ATCF-vA1 to IBCF-vA1) - see example in table 5.11.3-6.

The ATCF-vA1 creates a new dialog towards SCC AS-hA1 by sending an INVITE due to ATU-STI. Everything except the Request line and the Via header field is copied from the received INVITE due to STN-SR.

Table 5.11.3-6: INVITE request due to ATU-STI (ATCF-vA1 to IBCF-vA1)

```
INVITE sip:ps2cs@sccas1.home-A.net;iotl=visitedA-homeA SIP/2.0

From: <tel:+12375551111>;tag=171828
To: <tel:+12375553333>
Route: <sip:ibcf-vA1.visited-A.net;lr>
P-Asserted-Identity: <tel:+12375551111>
P-Access-Network-Info: 3GPP-UTRAN-TDD;utran-cell-id-3gpp=151234D0EAF22;network-provided;
local-time-zone="UTC+01:10";daylight-saving-time="01"
P-Charging-Vector: icid-value="023551024"; orig-ioi="Type lvisited-a";
icid-generated-at="msc-vA1.visited-A.net"
Record-Route: <sip:atcf-vA1.visited-A.net:5070;lr>
Contact: <sip:msc-vA1.visited-A.net:1357>;+g.3gpp.icsi-ref="urn%3Aurn-7%3A3gpp-
service.ims.icsi.mmtel";+g.3gpp.srvcc-alerting;+g.3gpp.mid-call;+ps2cs-srvss-orig-pre-alerting
CSeq: 11 INVITE
Accept: "application/vnd.3gpp.state-and-event-info+xml"
Recv-Info: g.3gpp.state-and-event
Target-Dialog: me03a0s09a2sdfgjk1491777; remote-tag=774321; local-tag=4fa3
Required: tdialog
Supported:norefersub

Via: SIP/2.0/UDP atcf-vA1.visited-A.net;branch=z9hG4bk731b87
```

Other SIP header fields and SDP according to 3GPP TS 24.229 [4] and 3GPP TS 24.237 [20].
--

Request-URI:	The SIP URI (referred to as ATU-STI) identifies the SCC AS-hA1. The ATU-STI is sent by SCC AS-hA1 to ATCF-vA1 during registration as described in clause 5.11.2. The Request-URI includes traffic information in an "iotl" SIP URI parameter according to IETF RFC 7549 [26].
Record-Route:	The address that the ATCF-vA1 wants to receive subsequent in-dialog requests from the SCC AS-hA1.
Target-Dialog:	The identity of the dialog selected by ATCF-vA1.
Required:	The "tdialog" option tag indicates that the support for Target-Dialog header field is required.
Via:	The ATCF-vA1 adds a Via header field.

7. INVITE request due to ATU-STI (IBCF-vA1 to IC-A1) - see example in table 5.11.3-7.

When the IBCF-vA1 receives the INVITE due to ATU-STI, the IBCF-vA1 updates the SDP as described within 3GPP TS 29.079 [5].

The IBCF-vA1 selects, based on local policy, to route the INVITE request due to ATU-STI via interconnect network A and sends the request according to 3GPP TS 24.229 [4] to the IC-A1. The IBCF-vA1 determines the next hop IP address from the SIP request URI, either by configured information or using a DNS query according to IETF RFC 3263 [13]. If the subsequent interconnection network is SIP-aware, the determined IP address will belong to the SIP proxy IC-A1. Otherwise the determined IP address will point to IBCF-vA1 and step 22 is skipped (not reflected in message details below).

Table 5.11.3-7: INVITE request due to ATU-STI (IBCF-vA1 to IC-A1)

<pre> INVITE sip:ps2cs@sccas1.home-A.net;iotl=visitedA-homeA SIP/2.0 From: To: Route: <sip:ic-A1.interconnection-A.net;lr> P-Access-Network-Info: P-Charging-Vector: Record-Route: <sip:ibcf-vA1.visited-A.net;lr>,<sip:atcf-vA1.visited-A.net:5070;lr> P-Asserted-Identity: Contact: CSeq: Accept: Recv-Info: Target-Dialog: Require: Supported: Via: SIP/2.0/UDP ibcf-vA1.visited-A.net;branch=z9hG4bk79c54a Via: SIP/2.0/UDP atcf-vA1.visited-A.net;branch=z9hG4bk7987fe Other SIP headerfields and SDP according to 3GPP TS 24.229 [4] and 3GPP TS 29.079 [5]. </pre>

Record-Route: Based on topology hiding functionality the IBCF-vA1 will either forward the Record-Route header field with:

- one visible IBCF-vA1 entry and the ATCF-vA1 entry as one hidden entry; or
- both the IBCF-vA1 entry and the ATCF-vA1 entry as visible entries.

Via: Based on topology hiding functionality the IBCF-vA1 will either forward the Via header fields with:

- one visible IBCF-vA1 entry and the ATCF-vA1 entry as one hidden entry; or
- both the IBCF-vA1 entry and the ATCF-vA1 entry as visible entries.

NOTE 3: In the example above both the IBCF-vA1 entry and the ATCF-vA1 entry are forwarded as visible entries in the Via and Record-Route header fields.

8. INVITE request due to ATU-STI (IC-A1 to IBCF-hA1) - see example in table 5.11.3-8.

NOTE 4: If the interconnection network is SIP-unaware, step 8 is skipped.

When the IC-A1 receives the initial INVITE request due to ATU-STI and since the IC-A1 according to local policy allows itself to be bypassed by media then the IC-A1 updates the SDP as described within 3GPP TS 29.079 [5].

The IC-A1 selects an entry point (IBCF-hA1) of the home IMS network hA and sends the INVITE request according to 3GPP TS 24.229 [4] to the IBCF-hA1.

NOTE 5: The IC-A1 can add a Route header field entry pointing to the entry point of home network hA. However, since this is not necessary for routing the call it is not shown in table 5.11.3-8.

Table 5.11.3-8: INVITE request due to ATU-STI (IC-A1 to IBCF-hA1)

```
INVITE sip:ps2cs@sccas1.home-A.net;iotl=visitedA-homeA SIP/2.0
From:
To:
P-Access-Network-Info:
P-Charging-Vector: icid-value="023551024";orig-ioi="Type lvisited-a";
    icid-generated-at="msc-vA1.visited-A.net";transit-ioi="ICa.1"
Target-Dialog:
Require:
Record-Route: <sip:ic-A1.interconnection-A.net;lr>,<sip:ibcf-vA1.visited-A.net;lr>,
    <sip:atcf-vA1.visited-A.net:5070;lr>
P-Asserted-Identity:
Contact:
CSeq:
Accept:
Recv-Info:
Supported:

Via: SIP/2.0/UDP ic-A1.interconnection-A.net;branch=z9hG4bk73eb11
Via: SIP/2.0/UDP ibcf-vA1.visited-A.net;branch=z9hG4bk79c54a
Via: SIP/2.0/UDP atcf-vA1.visited-A.net;branch=z9hG4bk7987fe

Other SIP header fields and SDP according to 3GPP TS 24.229 [4] and 3GPP TS 29.079 [5].
```

P-Charging-Vector: The IC-A1 adds the "transit-ioi" header field parameter with an IOI value identifying the transit network (i.e. "ICa").

Record-Route: Based on interconnection operator SLA the IC-A1 adds an entry to the Record-Route header field or not.

Via: The IC-A1 adds a Via header field.

9. INVITE request due to ATU-STI (IBCF-hA1 to SCC AS-hA1 via I-CSCF) - see example in table 5.11.3-9.

When the IBCF-hA1 receives the INVITE request due to ATU-STI the IBCF-hA1 updates the SDP as described in 3GPP TS 29.079 [5].

Since there is no Route header field guiding the IBCF-hA1 where to route the call the IBCF-hA1 selects an I-CSCF in the home network and sends the INVITE request due to ATU-STI to the selected I-CSCF according to 3GPP TS 24.229 [4].

In this example, the IBCF-hA1 does not add any "transit-ioi" header field parameter in the P-Charging-Vector header field. However, the IBCF-hA1 adds the "transit-ioi" header field parameter based on local policy, when the "transit-ioi" identifying the preceding interconnection network is not included in the received request (e.g. when the preceding interconnection network is not an IMS transit network).

The I-CSCF uses PSI routing to route the call and sends the INVITE request due to ATU-STI directly to SCC AS-hA1.

The table 5.11.3.9 shows the content of the INVITE request due to ATU-STI when received in the SCC AS-hA1.

Table 5.11.3-9: INVITE request due to ATU-STI (IBCF-hA1 to SCC AS-hA1 via I-CSCF)

```
INVITE sip:ps2cs@sccas1.home-A.net;iotl=visitedA-homeA SIP/2.0
```

```

From:
To:
P-Access-Network-Info:
P-Charging-Vector:
Target-Dialog:
Require:
Record-Route: <sip:ibcf-hA1.home-A.net;lr>,<sip:ic-A1.interconnection-A.net;lr>,<sip:ibcf-vA1.visited-A.net;lr>,<sip:atcf-vA1.visited-A.net:5070;lr>
P-Asserted-Identity:
Contact:
CSeq:
Accept:
Recv-Info:
Supported:

Via: SIP/2.0/UDP icscf-hA1.home-A.net;branch=z9hG4bk7e75ca1
Via: SIP/2.0/UDP ibcf-hA1.home-A.net;branch=z9hG4bk769aff3
Via: SIP/2.0/UDP ic-A1.interconnection-A.net;branch=z9hG4bk73eb11
Via: SIP/2.0/UDP ibcf-vA1.visited-A.net;branch=z9hG4bk79c54a
Via: SIP/2.0/UDP atcf-vA1.visited-A.net;branch=z9hG4bk7987fe

Other SIP header fields and SDP according to 3GPP TS 24.229 [4], 3GPP TS 24.237 [20] and 3GPP TS 29.079 [5].

```

Record-Route: The IBCF-hA1 adds a Record-Route header field.

Via: The IBCF-hA1 adds a Via header field.
The I-CSCF-hA1 adds a Via header field.

10. INVITE request (SCC AS-hA1 to S-CSCF-hA1) - see example in table 5.11.3-10.

When the SCC AS-hA1 receives the INVITE request due to ATU-STI the SCC AS-hA1 compares the received SDP with the SDP negotiated in the existing session. The conclusion is that it differs so the SCC AS-hA1 needs to send a re-INVITE request towards the remote UE.

NOTE 6: The AS can either remove the OMR attributes in the SDP or keep them depending on if the AS supports OMR and local policy. In this example the OMR attributes are removed.

NOTE 7: When a user is roaming and media is anchored in IBCF the IP addresses will be different in the SDP received in the INVITE request due to ATU-STI compared to those negotiated in the existing session towards the remote UE and that will always result in that a re-INVITE request is needed towards the remote UE.

Table 5.11.3-10: INVITE request (SCC AS-hA1 to S-CSCF-hA1)

```

INVITE sip:[5555::bbb:ccc:ddd:aaa] SIP/2.0

From: <sip:userA_public1@home-A.net>;tag=4fa3
To: <tel:+4687197378>;tag=987651
CSeq: 1000 INVITE
Route: <sip:scscf-hA1.home-A.net:5070;lr>,<sip:ibcf-hA2.home-A.net:5070;lr>,<The set of routes recorded when the call was established>

Via: SIP/2.0/UDP sccas-hA1.home-A.net;branch=z9hG4bK3a4f92

Other SIP header fields and updated SDP according to 3GPP TS 24.229 [4] and 3GPP TS 24.237 [20].

```

Request-URI: Set to the contact address of the remote UE.

From: Set to the SIP URI that is the default public user identity of the user A i.e. userA_public1@home-A.net.

To: Set to the public user identity of the remote UE.

Via: The SCC AS-hA1 adds a Via header field.

11. INVITE request (S-CSCF-hA1 to IBCF-hA2) - see example in table 5.11.3-11.

The S-CSCF-hA1 forwards the re-INVITE request according to procedures in 3GPP TS 24.229 [4].

Table 5.11.3-11: INVITE request (S-CSCF-hA1 to IBCF-hA2)

```

INVITE sip:[5555::bbb:ccc:ddd:aaa] SIP/2.0

From:
To:
CSeq:
Route: <sip:ibcf-hA2.home-A.net:5070;lr>,<The set of routes recorded when the call was established>

Via: SIP/2.0/UDP scscf-hA1.home-A.net;branch=z9hG4bK354321
Via: SIP/2.0/UDP sccas-hA1.home-A.net;branch=z9hG4bK3a4f92

Other SIP header fields and updated SDP according to 3GPP TS 24.229 [4] and 3GPP TS 24.237 [20].

```

Via: The S-CSCF-hA1 adds a Via header field.

12-13. 200 (OK) response (IBCF-hA2 to SCC AS-hA1 via S-CSCF-hA1).

When the IBCF-hA2 receives the 200 (OK) response to the re-INVITE request sent towards the remote UE, the IBCF-hA2 forwards the 200 (OK) response to SCC AS-hA1 according to 3GPP TS 24.229 [4]. The 200 (OK) response does not contain any SRVCC specific information.

14-15. ACK request (SCC AS-hA1 to IBCF-hA2 via S-CSCF-hA1).

The SCC AS-hA1 sends the ACK to the IBCF-hA2 according to 3GPP TS 24.229 [4]. The ACK request does not contain any SRVCC specific information.

16-20. 200 (OK) response (SCC AS-hA1 to ATCF-vA1 via S-CSCF-hA1, IBCF-hA1, IC-A1 and IBCF-vA1) - see example in table 5.11.3-20.

The SCC AS-hA1 uses the received SDP response and sends a 200 OK response to the INVITE request due to ATU-STI towards the ATCF-vA1.

The table 5.11.3-20 shows the content of the 200 (OK) response when received in ATCF-vA1.

Table 5.11.3-20: 200 (OK) response (IBCF-vA1 to ATCF-vA1)

```

SIP/2.0 200 OK

From: <tel:+1-237-555-1111>;tag=171828
To: <tel:+1-237-555-3333>;tag=828171
CSeq: 11 INVITE
Record-Route: <sip:ibcf-hA1.home-A.net;lr>,<sip:ic-A1.interconnection-A.net;lr>,<
  <sip:ibcf-vA1.visited-A.net;lr>,<sip:atcf-vA1.visited-A.net;lr>
P-Charging-Vector: icid-value="023551024";orig-ioi="Type 1visited-a";icid-generated-at="msc-
vA1.visited-A.net";term-ioi="Type 1home-a";related-icid="AyretyU0dm+6O2IrT5tAFrbHLso=023551024"

Via: SIP/2.0/UDP atcf-vA1.visited-A.net;branch=z9hG4bK7987fe

Other SIP header fields and SDP according to 3GPP TS 24.229 [4].

```

P-Charging-Vector: The SCC AS added the P-Charging-Vector with the "icid-value", the "orig-ioi" value and the "icid-generated-at" as received in the INVITE due to ATU-STI. Additionally the SCC AS-hA1 added the "related-icid" header field parameter. The "related-icid" header field parameter contains the "icid-value" header field parameter of the original call and can be used for charging correlation of generated CDR records in the interconnect network A.

NOTE 8: If the interconnection network is SIP-unaware, step 19 is skipped.

21-24. ACK request (ATCF-vA1 to SCC AS-hA1 via IBCF-vA1, IC-A1, IBCF-hA1 and S-CSCF-hA1).

The ATCF-vA1 sends the ACK to the SCC AS-hA1 according to 3GPP TS 24.229 [4]. The ACK request does not contain any SRVCC specific information.

NOTE 9: If the interconnection network is SIP-unaware, step 22 is skipped.

5.11.4 PS to CS SRVCC access transfer for a call in the active phase with loopback

This clause describes the PS to CS SRVCC access transfer of a call in the active phase with loopback.

Preconditions to this call flow:

1. A call is established between a UE-A and a remote UE as described in clause 5.4. The UE-A is attached to a 4G radio access network (E-UTRAN);
- NOTE 1: The signalling flow is the same for PS to CS SRVCC access transfer for a call in the active phase regardless if the UE-A or the remote UE initiated the call.
2. The media is anchored in the P-CSCF-vA1, ATCF-vA1 and IBCF-vA1 in the visited network vA); and
 3. SIP signalling is anchored in SCC AS-hA1.

Figure 5.11.4-1 shows the SIP message flow when PS to CS SRVCC access transfer of a call in the active phase occurs.

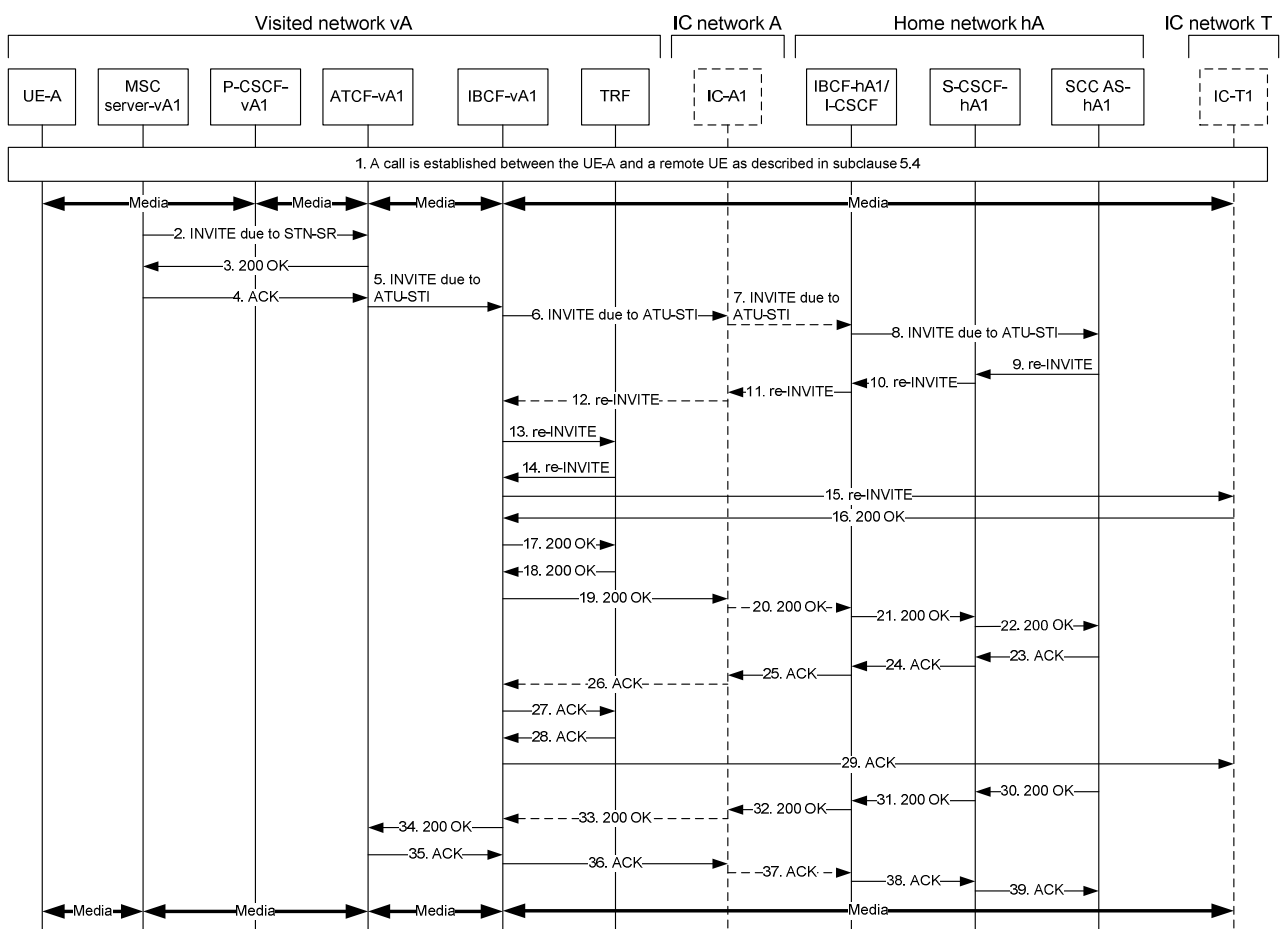

NOTE: For clarity, the SIP 100 (Trying) messages are not shown in the signalling flow.

Figure 5.11.4-1: SRVCC with loopback message flow

The steps of the flow are as follows:

1. A call is established between the UE-A and a remote UE as described in clause 5.4.

The remote UE can be a UE connected to IMS or an UE connected to CS and the difference compared to the description in clause 5.4 and this PS to CS SRVCC access transfer scenario is that an ATCF in the visited originated network participated in the call establishment of the call and that the general AS-hA1 in figure 5.4.2-1 is replaced by the access transfer specific SCC AS-hA1.

The media path is UE-A – P-CSCF-vA1 – ATCF-vA1 – IBCF-vA1 – IC-T1 – terminating network – remote UE.

2. INVITE request due to STN-SR (MSC server-vA1 to ATCF-vA1).

See step 3 in clause 5.11.3.

3. 200 (OK) response (ATCF-vA1 to MSC server-vA1).

See step 4 in clause 5.11.3.

4. ACK request (MSC server-vA1 to ATCF-vA1).

The MSC server acknowledges the receipt of the 200 (OK) response. No SRVCC specific information is added.

5-8. INVITE request due to ATU-STI (ATCF-vA1 to SCC AS-hA1 via IBCF-vA1, IC-A1, IBCF-hA1/I-CSCF and S-CSCF-hA1).

See steps 6-9 in clause 5.11.3.

NOTE 2: If the interconnection network is SIP-unaware, step 7 is skipped.

9-15. INVITE request (SCC AS-hA1 to IC-T1 via S-CSCF-hA1, IBCF-hA1, IC-A1, IBCF-vA1, TRF and IBCF-vA1) - see example in table 5.11.4-9.

When the SCC AS-hA1 receives the INVITE request due to ATU-STI the SCC AS-hA1 compares the received SDP with the SDP negotiated in the existing session. The conclusion is that it differs so the SCC AS-hA1 needs to send a re-INVITE request towards the remote UE.

The SCC AS-hA1 handles OMR attributes according to 3GPP TS 24.237 [20] clause 6A.4.4.

NOTE 3: When a user is roaming and media is anchored in IBCF the IP addresses will be different in the SDP received in the INVITE request due to ATU-STI compared to those negotiated in the existing session towards the remote UE and that will always result in that a re-INVITE request is needed towards the remote UE.

The table 5.11.4-9 shows the content of the INVITE request when sent by SCC AS-hA1.

Table 5.11.4-9: INVITE request (SCC AS-hA1 to IC-T1 via S-CSCF-hA1, IBCF-hA1, IC-A1, IBCF-vA1, TRF and IBCF-vA1)

```
INVITE sip:[5555::bbb:ccc:ddd:aaa] SIP/2.0

From: <tel:+1-237-555-1111>;tag=171828
To: <tel:+4687197378>;tag=987651
CSeq: 111 INVITE
Route: <sip:scscf-hA1.home-A.net:5070;lr>,<sip:ibcf-hA2.home-A.net:5070;lr>,
      <The set of routes recorded when the call was established>

Via: SIP/2.0/UDP sccas-hA1.home-A.net;branch=z9hG4bK3a4f92

Other SIP header fields and updated SDP according to 3GPP TS 24.229 [4], 3GPP TS 24.237 [20] and
3GPP TS 29.079 [5].
```

Via: Via header fields are added by SCC AS-hA1, S-CSCF-hA1, IBCF-hA1, IC-A1, IBCF-vA1, TRF and IBCF-vA1.

NOTE 4: If the interconnection network is SIP-unaware, step 12 is skipped.

16-22. 200 (OK) response (IC-T1 to SCC AS-hA1 via IBCF-vA1, TRF, IBCF-vA1, IC-A1, IBCF-hA1 and S-CSCF-hA1).

When receiving a 200 (OK) response to the re-INVITE request from the remote UE the IC-T1 returns a 200 (OK) response. No SRVCC specific information is added.

NOTE 5: If the interconnection network is SIP-unaware, step 20 is skipped.

23-29. ACK request (SCC AS-hA1 to IC-T1 via S-CSCF-hA1, IBCF-hA1, IC-A1, IBCF-vA1, TRF and IBCF-vA1).

The SCC AS-hA1 acknowledges the receipt of the 200 (OK) response. No SRVCC specific information is added.

NOTE 6: If the interconnection network is SIP-unaware, step 26 is skipped.

30-34. 200 (OK) response (SCC AS-hA1 to ATCF-vA1 via S-CSCF-hA1, IBCF-hA1, IC-A1 and IBCF-vA1).

See steps 16-20 in clause 5.11.3.

NOTE 7: If the interconnection network is SIP-unaware, step 33 is skipped.

35-39. ACK request (ATCF-vA1 to SCC AS-hA1 via IBCF-vA1, IC-A1, IBCF-hA1/I-CSCF and S-CSCF-hA1).

The ATCF-vA1 acknowledges the receipt of the 200 (OK) response. No SRVCC specific information is added.

NOTE 8: If the interconnection network is SIP-unaware, step 37 is skipped.

5.12 Invocation and configuration of services during roaming in a visited network

This case describes how the user within a visited network invokes services via the Ut interface.

GSMA IR.88 [15] describes that the home operator must provide an APN to be used by the UE for XCAP/Ut. For the UE details see GSMA IR.92 [8].

The IMS "well-known" APN must not be used as APN for XCAP/Ut as defined in Section 6.3.2 of GSMA IR.88 [15].

In addition GSMA IR.92 [8] describes that for XCAP requests, the UE must be preconfigured or provisioned by the home operator with the APN to be used for XCAP requests.

Editor's note: It needs to be clarified and described which correlation between the SIP Call Signalling and the http flows are existing.

Editor's note: It needs to be clarified and described which security mechanisms are used.

Annex A: Change history

Change history								
Date	TSG #	TSG Doc.	CR	Rev	Subject/Comment		Old	New
2014-12	CT#66	CP-140930			Approved and brought under change control		2.0.0	12.0.0
2015-03	CT#67	CP-150113	1	1	Reference update: draft-holmberg-dispatch-iotl		12.0.0	13.0.0
2015-06	CT#68	CP-150349	000 3	-	draft-holmberg-dispatch-iotl-parameter-04 updated to RFC 7549		13.0.0	13.1.0
2015-09	CT#69	CP-150478	000 4	-	Applying THIG on Path header field		13.1.0	13.2.0
2015-12	CT#70	CP-150651	000 6	-1	Loopback Indication in Responses		13.2.0	13.3.0
2015-12	CT#70	CP-150651	000 7	-2	Correction for the format of the Feature-Caps and the Relayed-Charge		13.2.0	13.3.0
2015-12	CT#70	CP-150651	001 0	-	Removal of the P-Charging Vector header field of the SIP 183 response (P-CSCF to UE)		13.2.0	13.3.0
Change history								
Date	TSG #	TSG Doc.	CR	Rev	Cat	Subject/Comment	New	
2017-03	CT#75					Automatic upgrade from previous Release	14.0.0	
2018-06	SA#80	-	-	-		Automatic upgrade from previous Release	15.0.0	

History

Document history		
V15.0.0	July 2018	Publication