

ETSI TR 126 969 V8.2.0 (2011-04)

Technical Report

**Digital cellular telecommunications system (Phase 2+);
Universal Mobile Telecommunications System (UMTS);
eCall data transfer;
In-band modem solution;
Characterization report
(3GPP TR 26.969 version 8.2.0 Release 8)**



Reference

RTR/TSGS-0426969v820

Keywords

GSM, UMTS

ETSI

650 Route des Lucioles
F-06921 Sophia Antipolis Cedex - FRANCE

Tel.: +33 4 92 94 42 00 Fax: +33 4 93 65 47 16

Siret N° 348 623 562 00017 - NAF 742 C
Association à but non lucratif enregistrée à la
Sous-Préfecture de Grasse (06) N° 7803/88

Important notice

Individual copies of the present document can be downloaded from:

<http://www.etsi.org>

The present document may be made available in more than one electronic version or in print. In any case of existing or perceived difference in contents between such versions, the reference version is the Portable Document Format (PDF). In case of dispute, the reference shall be the printing on ETSI printers of the PDF version kept on a specific network drive within ETSI Secretariat.

Users of the present document should be aware that the document may be subject to revision or change of status. Information on the current status of this and other ETSI documents is available at

<http://portal.etsi.org/tb/status/status.asp>

If you find errors in the present document, please send your comment to one of the following services:

http://portal.etsi.org/chaicor/ETSI_support.asp

Copyright Notification

No part may be reproduced except as authorized by written permission.
The copyright and the foregoing restriction extend to reproduction in all media.

© European Telecommunications Standards Institute 2011.
All rights reserved.

DECTTM, **PLUGTESTS**TM, **UMTS**TM, **TIPHON**TM, the TIPHON logo and the ETSI logo are Trade Marks of ETSI registered for the benefit of its Members.

3GPPTM is a Trade Mark of ETSI registered for the benefit of its Members and of the 3GPP Organizational Partners.

LTETM is a Trade Mark of ETSI currently being registered

for the benefit of its Members and of the 3GPP Organizational Partners.

GSM[®] and the GSM logo are Trade Marks registered and owned by the GSM Association.

Intellectual Property Rights

IPRs essential or potentially essential to the present document may have been declared to ETSI. The information pertaining to these essential IPRs, if any, is publicly available for **ETSI members and non-members**, and can be found in ETSI SR 000 314: *"Intellectual Property Rights (IPRs); Essential, or potentially Essential, IPRs notified to ETSI in respect of ETSI standards"*, which is available from the ETSI Secretariat. Latest updates are available on the ETSI Web server (<http://webapp.etsi.org/IPR/home.asp>).

Pursuant to the ETSI IPR Policy, no investigation, including IPR searches, has been carried out by ETSI. No guarantee can be given as to the existence of other IPRs not referenced in ETSI SR 000 314 (or the updates on the ETSI Web server) which are, or may be, or may become, essential to the present document.

Foreword

This Technical Report (TR) has been produced by ETSI 3rd Generation Partnership Project (3GPP).

The present document may refer to technical specifications or reports using their 3GPP identities, UMTS identities or GSM identities. These should be interpreted as being references to the corresponding ETSI deliverables.

The cross reference between GSM, UMTS, 3GPP and ETSI identities can be found under <http://webapp.etsi.org/key/queryform.asp>.

Contents

Intellectual Property Rights	2
Foreword.....	2
Foreword.....	5
Introduction	5
1 Scope	6
2 References	6
3 Definitions and abbreviations.....	7
3.1 Definitions	7
3.2 Abbreviations	8
4 Selection tests.....	9
4.1 Performance objectives and requirements.....	9
4.1.1 Test procedures	10
4.1.2 Test results	11
4.2 Design constraints	11
4.2.1 Test procedures	12
4.2.2 Test results	12
5 Verification and characterization tests	12
5.1 Performance with dynamic jitter buffer.....	13
5.2 Performance with echo cancellation.....	15
5.3 Performance with transcoding.....	16
5.3.1 Performance with ITU-T G.711&G.726 transcoding	17
5.3.2 Performance with ITU-T G.729 A/B transcoding.....	17
5.4 Performance with packet loss concealment techniques	18
5.5 Performance with other codec types.....	20
5.5.1 GSM HR	20
5.5.2 GSM EFR	20
5.5.3 HR AMR.....	21
5.5.4 AMR-WB	22
5.6 Performance with additional channel conditions.....	24
5.6.1 Different C/I.....	24
5.6.2 AGC variations	25
5.7 Varying channel conditions.....	26
5.7.1 Description of test setup	26
5.7.2 Test results	27
5.8 Performance with static jitter buffer	27
5.8.1 Simulation Methodology	29
5.8.2 Jitter buffer with ITU-T G.711 A-law speech frames.....	30
5.8.3 Jitter buffer with ITU-T G.729 speech frames.....	30
5.9 Noisy conditions.....	30
5.10 Erroneous tone detection	32
5.11 Gaps in transmission due to handovers	32
5.12 Change of speech codec	34
5.12.1 Change of AMR codec modes	34
5.12.2 Change of speech codec in handover	35
5.13 Sample slip / small delay variations at handover.....	36
5.14 Combinations of test conditions	36
5.14.1 GSM HR and HR AMR with transcoding (G.729 / G.726) under different channel conditions	36
5.14.2 CSoHS with transcoding (G.729a / G.711) and echo cancellation	37
Annex A: eCall test setup	38
A.1.1 Measurement of the MSD transmission time	40

Annex B:	Required transmission times for IVS initiated eCall signalling and HL-ACK	43
Annex C:	Extended simulation results	44
C.1	Dynamic jitter buffer	44
C.2	Transcoding	50
C.3	Sample slip	53
C.4	CSoHS with transcoding (G.729a / G.711) and echo cancellation	58
Annex D:	Change history	63
History	64

Foreword

This Technical Report has been produced by the 3rd Generation Partnership Project (3GPP).

The contents of the present document are subject to continuing work within the TSG and may change following formal TSG approval. Should the TSG modify the contents of the present document, it will be re-released by the TSG with an identifying change of release date and an increase in version number as follows:

Version x.y.z

where:

- x the first digit:
 - 1 presented to TSG for information;
 - 2 presented to TSG for approval;
 - 3 or greater indicates TSG approved document under change control.
- y the second digit is incremented for all changes of substance, i.e. technical enhancements, corrections, updates, etc.
- z the third digit is incremented when editorial only changes have been incorporated in the document.

Introduction

eCall refers to an interoperable in-vehicle emergency call service which is envisioned to be introduced and operated across Europe in 2014. According to reports from the European Commission, it is foreseen that eCall will be offered on all new vehicles in the EU by 2014.

The European Commission has brought together standardization bodies, the automotive industry, mobile telecommunication industry, public emergency authorities and others in the eSafety Forum initiative which has identified high-level requirements, recommendations and guidelines for this eCall service [2] and [3]. The eSafety Forum has assigned ETSI MSG to standardize those parts of the eCall service that affect the mobile communication system. The development of the eCall standard has been further delegated to the 3rd Generation Partnership Project (3GPP).

1 Scope

The present document characterizes the performance of the eCall In-band Modem, which is used for reliable transmission of the eCall Minimum Set of Data (MSD) from an In-Vehicle System (IVS) to the Public Safety Answering Point (PSAP) via the voice channel of cellular and PSTN networks.

The European Union eCall requirements, recommendations and guidelines were developed by eSafety Forum [3] and [4], with important additional work produced by ETSI MSG, GSME, 3GPP, and CEN.

Previous work in 3GPP TR 22.967 [5] "Transfer of Emergency Call Data", examined the issues associated with the transmission of emergency call data from a vehicle to a PSAP. This analysis identified that the preferred option be based on an in-band modem solution.

eCall provides reliable full-duplex data communications between IVS and PSAP in addition to emergency voice call (E112) via the cellular network, and can be initiated either automatically or manually [6]. The eCall In-band Modem uses the same voice channel as used for the emergency voice call. eCall allows reliable transmission of MSD alternating with a speech conversation through the existing voice communication paths in cellular mobile phone systems. The expected benefit is that emergency services will be made aware of accidents much more rapidly, will get precise information on location, vehicle type etc. and therefore will be able to reach accident victims faster, with the potential to save many lives annually.

The eCall in-band modems (IVS and PSAP) are fully specified by the "General description " TS 26.267 [9] together with the C-code reference as provided in 3GPP TS 26.268 [7]. 3GPP TS 26.269 [8] deals with the conformance testing for eCall modem implementations.

The present document provides a detailed performance characterization of the eCall in-band modem solution. Results from the 3GPP selection tests as well as verification and characterization tests have been collected into this report. It is impossible to test the eCall modem for all conditions that might arise on the transmission path from the IVS to the PSAP. However, the selected set of test scenarios represents a wide range of conditions that are foreseen to potentially occur in the in-band transmission of eCall data over the radio access and core networks as well as the PSTN.

2 References

The following documents contain provisions which, through reference in this text, constitute provisions of the present document.

- References are either specific (identified by date of publication, edition number, version number, etc.) or non-specific.
- For a specific reference, subsequent revisions do not apply.
- For a non-specific reference, the latest version applies. In the case of a reference to a 3GPP document (including a GSM document), a non-specific reference implicitly refers to the latest version of that document *in the same Release as the present document*.

- [1] 3GPP TR 21.905: "Vocabulary for 3GPP Specifications".
- [2] eSafety Forum eCall Driving Group: "European Memorandum of Understanding for Realisation of Interoperable In-Vehicle eCall", May 2004.
- [3] eSafety Forum: "Clarification Paper – EG.2 , High level requirements for a eCall in-vehicle system, Supplier perspective", March 2006, Version 1.0.
- [4] eSafety Forum: "Recommendations of the DG eCall for the introduction of the pan-European eCall", April 2006, Version 2.0.
- [5] 3GPP TR 22.967: "Transferring of Emergency Call Data".
- [6] 3GPP TS 22.101: "Service aspects; Service principles".
- [7] 3GPP TS 26.268: "eCall Data transfer; In-band modem solution; ANSI-C reference code".

- [8] 3GPP TS 26.269: "eCall Data Transfer; In-band modem solution; Conformance testing".
- [9] 3GPP TS 26.267: "eCall Data Transfer; In-band modem solution; General description".
- [10] 3GPP TS 26.226: "Cellular text telephone modem; General description".
- [11] 3GPP TS 26.230: "Cellular text telephone modem; Transmitter bit exact C-code".
- [12] ITU-T Recommendation G.726: "40, 32, 24, 16 kbit/s Adaptive Differential Pulse Code Modulation (ADPCM) of Audio Frequencies", 12/90.
- [13] ITU-T Recommendation G.729: "Coding of speech at 8 kbit/s using conjugate-structure algebraic-code-excited linear prediction (CS-ACELP)", 01/07.
- [14] http://portal.etsi.org/docbox/zArchive/SMG/SMG11/smg11_sq/HR/
- [15] 3GPP TS 46.006: "Half-rate speech: ANSI-C code for GSM half-rate speech codec".
- [16] http://portal.etsi.org/docbox/zArchive/SMG/SMG11/smg11_sq/EPx/
- [17] 3GPP TS 46.053: "ANSI-C code for the GSM Enhanced Full Rate (EFR) speech codec".
- [18] http://portal.etsi.org/docbox/zArchive/SMG/SMG11/smg11_amr_nb/ERROR_PATTERNS/
- [19] http://portal.etsi.org/docbox/zArchive/SMG/SMG11/SW_tool_library/EFR/
- [20] 3GPP TS 26.114: "IP Multimedia Subsystem (IMS); Multimedia Telephony; Media handling and inter-action"
- [21] 3GPP TS 46.010: "Full-rate speech; Transcoding"
- [22] 3GPP TS 46.060: "Enhanced Full Rate (EFR) speech transcoding".
- [23] 3GPP TS 26.071: "Mandatory speech CODEC speech processing functions; AMR speech Codec; General description".
- [24] 3GPP TS 26.171: "Speech codec speech processing functions; Adaptive Multi-Rate - Wideband (AMR-WB) speech codec; General description".
- [25] ITU-T Recommendation G.711: "Pulse Code Modulation (PCM) of Voice Frequencies", 11/88.
- [26] 3GPP TS 26.101: "Mandatory speech codec speech processing functions; Adaptive Multi-Rate (AMR) speech codec frame structure".
- [27] 3GPP TS 26.268: "eCall Data transfer; In-band modem solution; ANSI-C reference code", Version 8.0.0.
- [28] 3GPP TS 26.267: "eCall Data Transfer; In-band modem solution; General description", Version 8.0.0.
- [29] 3GPP TS 26.268: "eCall Data transfer; In-band modem solution; ANSI-C reference code", Version 8.6.0.
- [30] 3GPP TS 26.267: "eCall Data Transfer; In-band modem solution; General description", Version 8.6.0.

3 Definitions and abbreviations

3.1 Definitions

For the purposes of the present document, the terms and definitions given in TR 21.905 [1] and the following apply. A term defined in the present document takes precedence over the definition of the same term, if any, in TR 21.905 [1].

eCall: manually or automatically initiated emergency call (TS12) from a vehicle, supplemented with a minimum set of emergency related data (MSD), as defined under the EU Commission's eSafety initiative

eCall In-band Modem: modem pair (consisting of transmitters and receivers at IVS and PSAP) that operates full-duplex and allows reliable transmission of eCall Minimum Set of Data from IVS to PSAP via the voice channel of the emergency voice call through cellular and PSTN networks

eSafety: European Commission sponsored forum to improve safety aspects of European citizens

Figure of Merit (FoM): average MSD transmission time for the test campaign used in the eCall selection test, consisting of 26 different test conditions (see Table 1) and 100 tests for each condition. In the wider sense, the Figure of Merit can also include other channel impairments (e.g., noise or transcoding) apart from the speech codec and channel errors, but the average is always taken over the 2600 tests mentioned above

frame (or: speech frame): time interval equal to 20 ms (corresponding to one AMR or FR speech frame, represented by 160 samples at an 8 kHz sampling rate)

Minimum Set of Data (MSD): forming the data component of an eCall sent from a vehicle to a Public Safety Answering Point or other designated emergency call centre. The MSD has a maximum size of 140 bytes and includes, for example, vehicle identity, location information and time-stamp

MSD data frame: uplink signal transmission interval containing the data of one MSD (after synchronization has been established) - corresponds to a time interval of 1 080 ms or 8 640 samples (fast modulator) and 2 080 ms or 16 640 samples (robust modulator) assuming an 8 kHz sampling rate

modulation frame: symbol transmission time interval equal to 2 ms corresponding to 16 samples at 8 kHz sampling rate (fast modulator), or 4 ms corresponding to 32 samples at 8 kHz sampling rate (robust modulator).

synchronization frame: signal transmission interval containing synchronization information - corresponds to a time interval of 260 ms or 2 080 samples at an 8 kHz sampling rate

3.2 Abbreviations

For the purposes of the present document, the abbreviations given in TR 21.905 [1] and the following apply. An abbreviation defined in the present document takes precedence over the definition of the same abbreviation, if any, in TR 21.905 [1].

ACK	Acknowledgement
ADPCM	Adaptive Differential Pulse Code Modulation
AGC	Automatic Gain Control
AoIP	A-Interface User Plane over IP
AMR	Adaptive Multi-Rate (speech codec)
AMR-WB	AMR Wide-Band (speech codec)
AWGN	Additive White Gaussian Noise
CEN	Comité Européen de Normalisation
CRC	Cyclic Redundancy Check
CSoHS	Circuit-Switched over HSPA
CTM	Cellular Text telephone Modem
EID	Error Insertion Device
EU	European Union
FoM	Figure of Merit
FR	Full Rate (channel)
HR	Half Rate (channel)
GSM	Global System for Mobile communications
GSM EFR	GSM Enhanced Full Rate (speech codec)
GSM FR	GSM Full Rate (speech codec)
GSM HR	GSM Half Rate (speech codec)
GSME	GSM Europe
IVS	In-Vehicle System
MSD	Minimum Set of Data
MSG	Mobile Standards Group
NACK	Negative Acknowledgement
PCM	Pulse Code Modulation

PSAP	Public Safety Answering Point
PSTN	Public Switched Telephone Network
ROM	Read Only Memory
RSSI	Received Signal Strength Indicator
SIP-I	Session Initiation Protocol with encapsulated ISDN User Part
VAD	Voice Activity Detection

4 Selection tests

This clause describes test results according to the eCall selection tests. The selection tests were conducted by 3GPP to identify the performance of eCall in-band modem under typical conditions. The eCall in-band modem has been tested for certain performance objectives and design constraints.

Note that the original selection tests were carried out with a prototype version of the eCall modem software. The reference C-code implementation as specified in [27] contains some improvements of the modem that were agreed by the responsible 3GPP working group. The test results given in this report represent the performance of the reference modem implementation [27], i.e. the selection test items have been repeated with the improved version of the modem.

4.1 Performance objectives and requirements

The foremost performance objective in the selection test was that the overall average transmission time should be as small as possible. The average MSD transmission time over a typical set of channel conditions was determined and used as a Figure of Merit (FoM) for the eCall modem. The MSD transmission times are measured from the time when the transmission from the IVS to the PSAP begins (after a trigger from the PSAP has been detected).

Figure 1 illustrates the measured MSD transmission time in relation to the time required for setting up the transmission (push and/or pull messages) as well as acknowledging the successful MSD reception (lower layer ACK and higher-layer ACK).

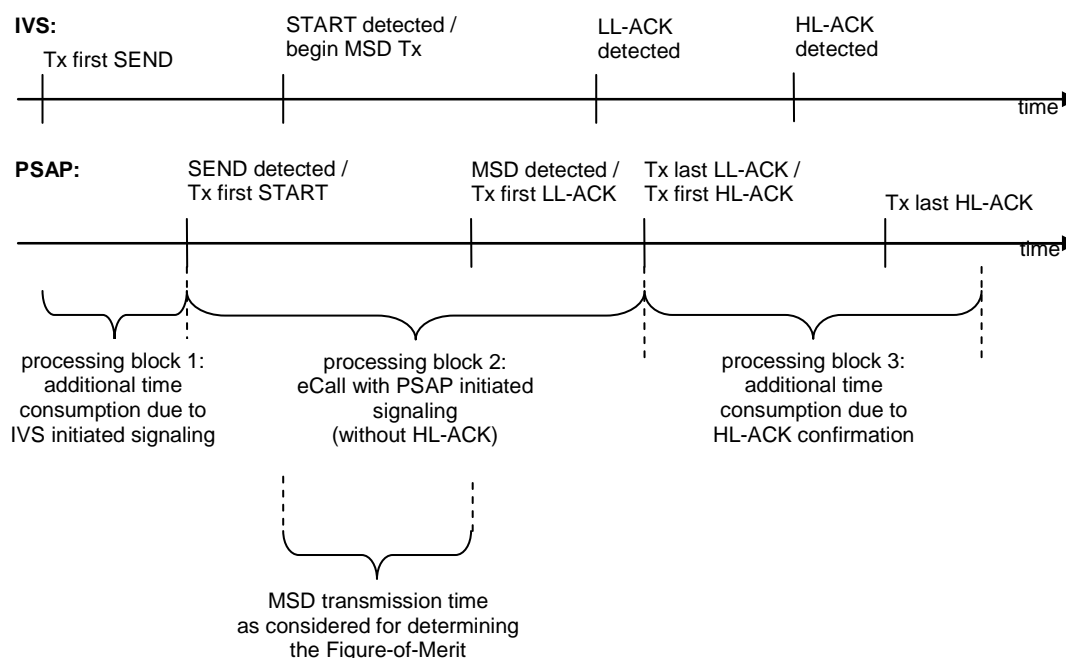

Figure 1: Timeline of eCall with IVS initiated signalling and HL-ACK in normal operation

(IVS-initiated signalling in processing block 1 can be omitted in an alternate modem configuration)

In Annex B, an estimate of the required times for processing blocks 1 and 3, as well as the parts of block 2 outside the Figure-of-Merit, is given.

As an eCall service requirement, in optimal conditions (error-free radio channel, GSM FR codec [21] and FR AMR [23] 12.2 kbit/s mode) the eCall procedure should be able to transmit the whole 140 bytes of the MSD reliably within 4 seconds.

The IVS modem should not false detect the tones in a 30 minute test PSTN tone file as PSAP triggers.

The procedures to test the performance objectives/requirements are explained in more detail below, followed by the corresponding performance figures of the eCall modem.

The test setup that was used in the selection tests for eCall is described in more detail in Annex A.

4.1.1 Test procedures

For any particular test condition (specified by speech codec plus radio channel error condition), the observed transmission time of the 140 bytes of the MSD may vary depending on the parameters of the channel simulation and the specific contents of the MSD. Therefore each MSD transmission may be regarded as one trial k in a random experiment, where the observed transmission time, T_k , is the random variable of interest. For each particular test condition C , the MSD transmission was repeated with different, randomly generated MSD data for at least 100 times ($k = 1, 2, \dots, n$, where $n \geq 100$) to get enough statistical significance.

To ensure a practical limit on the time required for testing, the observed value of T_k must have a reasonable upper bound. This upper bound, t_{UB} , was fixed at a value of 200 seconds for one trial for all test conditions. Any value of T_k that was observed to be greater than t_{UB} was classified as a transmission failure and was assigned the value of t_{UB} .

Each particular test condition C gave an observed sample distribution T_1, T_2, \dots, T_n . The statistic of interest is the average value, $\mu_C = (T_1 + T_2 + \dots + T_n) / n$.

The Figure of Merit (FoM) over all test conditions was calculated by unweighted averaging of μ_C over all particular test conditions C_1, C_2, \dots, C_m . A low Figure of Merit is – obviously - better than a higher Figure of Merit. In the original selection test, the eCall modem candidates were ranked by their Figures of Merit.

The following assumptions were made for the measurement of T_k .

- 1) The starting time of the transmission with respect to speech codec audio frames was uniformly distributed.
- 2) The channel error conditions were modelled by error patterns obtained from offline simulations (see Annex A for details). The error patterns represent residual errors after channel decoding. They are available together with the modem and test setup source code [7]. The following radio conditions were tested:
 - GMSK Full Rate radio channel at C/I values of 1, 4, 7, 10, 13, 16 dB, and error free; with ideal frequency hopping, with the Typical Urban profile and with slow vehicle speed. These channel conditions were applied in both directions (uplink and downlink) symmetrically.
 - GMSK Full Rate radio channel at RSSI value -100 dBm with no other interferer. This channel condition was applied in both directions (uplink and downlink) symmetrically. The RSSI = -100 dBm condition was included in the tests in order to model a rural scenario where little interference is present but the received signal power is low.

The following speech Codecs were tested: GSM FR [21] and FR AMR [23] (12.2, 10.2, 7.95, 7.4, 6.7, 5.9, 5.15, 4.75 kbps). DTX was enabled in both directions.

Table 1 in the next clause gives an allocation of studied codec and radio conditions in order to reduce the test effort to the reasonable minimum.

- 3) It was assumed that the transmission in the wireline part of the eCall uses PCM (G.711, A-law) without any further transcoding and with a fixed, pre-selected level setting.
- 4) It was assumed that no acoustical echo is produced by the IVS and that therefore no Acoustic Echo Suppressor is applied in the network.
- 5) It was assumed that no Hybrid Echo (i.e., echo caused by signal reflection at interfaces in a PSTN) is produced by the PSAP connection and that therefore no Hybrid Echo canceller is applied in the network.

- 6) The MSD contained randomly generated data. (Each possible byte sequence was considered to be equally probable.)
- 7) The round-trip delay between the IVS and PSAP was a randomly generated value in the range (200 ms, 220 ms).

To perform the false trigger test, a PSAP modem was implemented that transmits a tone file on the downlink to the IVS. The IVS was monitored for any output signal.

4.1.2 Test results

The MSD transmission times for the eCall modem [27], obtained in a test according to the above procedures and assumptions, are given in Table 1. The according 95th percentile values (i.e., the limits which at least 95% of transmission times fall below) are given in Table 2. Note that in the characterization phase, more codec and C/I combinations were tested, and the results tables were updated (see Table 20).

Table 1: Average MSD transmission times

Condition	Average MSD transmission time (in s) per condition								
	GSM FR	AMR 12.2	AMR 10.2	AMR 7.95	AMR 7.4	AMR 6.7	AMR 5.9	AMR 5.15	AMR 4.75
C/I = 1 dB									4.07
C/I = 4 dB							2.41	3.10	3.38
C/I = 7 dB	2.29	1.91	1.80	1.69	1.68	2.01	2.10	2.57	3.12
C/I = 10 dB	1.66	1.53	1.42	1.56	1.59				
C/I = 13 dB	1.45	1.36	1.36						
C/I = 16 dB	1.39								
error free	1.37	1.35							
RSSI = -100 dBm	1.50								3.12

Table 2: 95th percentiles of MSD transmission times

Condition	95th percentiles of MSD transmission time (in s) per condition								
	GSM FR	AMR 12.2	AMR 10.2	AMR 7.95	AMR 7.4	AMR 6.7	AMR 5.9	AMR 5.15	AMR 4.75
C/I = 1 dB									4.60
C/I = 4 dB							2.80	3.54	3.90
C/I = 7 dB	3.68	2.08	2.08	1.76	1.74	2.10	2.42	3.14	3.88
C/I = 10 dB	2.06	1.74	1.74	1.74	1.74				
C/I = 13 dB	1.74	1.36	1.36						
C/I = 16 dB	1.72								
error free	1.36	1.36							
RSSI = -100 dBm	1.74								3.52

The overall average of all measured transmission times (the Figure of Merit) is 2.03 s., with a 95th percentile of 3.54 s.

With the updated in-band modem version, the Figure of Merit increases to 2.28 s (95th percentile of 4.16 s). This increase is mainly caused by additional uplink signal components that were required to enable uplink synchronization tracking. For detailed test results per codec and C/I condition of the updated modem, refer to Table 20b.

No false IVS triggers due to the tone test file were observed.

4.2 Design constraints

Apart from the primary objective of a fast MSD transmissions, design constraints were considered in the development of the eCall in-band modem. Several of the design constraints were checked in the eCall selection tests:

- 1) The MSD shall be transmitted reliably to the PSAP. An MSD transmission is considered reliably terminated, if a cyclic redundancy check (CRC) of at least 28 bits, applied to the entire MSD, detects no errors.
- 2) The algorithm as implemented in the IVS should not have more than 10 times the complexity of CTM [10]. The algorithm as implemented in the PSAP should not have more than 20 times the complexity of CTM [10].

- 3) The algorithm as implemented in the IVS should not require more than 20KB of data memory.
The algorithm as implemented in the PSAP should not require more than 40KB of data memory.

4.2.1 Test procedures

Design constraints 1) and 3) were tested by inspection of the eCall modem reference C-code [27]. Regarding constraint 3), memory for data only was considered, including static and global variables, constants, and maximum amount of dynamically allocated memory. Code memory and ROM tables were not counted.

With respect to design constraint 2), the complexity was estimated by compiling the eCall [27] and CTM [11] C-codes under similar compiler conditions and then measuring the processing times.

4.2.2 Test results

- 1) The eCall in-band modem makes use of a 28-bit CRC to guarantee a reliable MSD transmission. This CRC is realized in the reference C-code [7], and is described in more detail in [9].
- 2) The modem complexity was checked for three representative channel conditions. The results are summarized in Table 3 below.

Table 3: eCall modem complexity

Condition	Complexity with respect to CTM [10] (# times more computationally complex)		Approximate processing time per frame in μ s (on an Intel Core 2 Duo processor)	
	IVS	PSAP	IVS	PSAP
AMR 12.2 Error Free	0.39	1.17	41.7	125.2
AMR 12.2 C/I=7dB	0.33	2.23	35.3	239.6
AMR 4.75 C/I=4dB	0.23	4.04	24.6	432.3

- 3) For the IVS modem, the total memory required is 9.1 KB.

For the PSAP modem, the total memory required is 32.3 KB.

5 Verification and characterization tests

This clause reports on the results of the verification and characterization testing performed for the eCall in-band modem in its initial version ([27], [28]). Some of the tests have been repeated using a more recent version of the modem ([29], [30]), and the latest results are reported additionally in these cases. Table 4 provides an overview of all verification and characterization items tested, also indicating the modem version that has been used for testing.

**Table 4: Verification and characterization test items, and tested modem versions;
"V" indicates a verification item**

Item	Description	Versions
1	Performance with dynamic jitter buffer (IMS and MTSI)	[27], [29]
2	Performance with echo cancellation V	[27]
3	Performance with transcoding (G.729A, G.729B, and G.726 at 32kbps) V	[27], [29]
4	Performance with packet loss concealment techniques (G.711 with dropped 20msec frames – not more than 1% frame loss) V	[27]
5	Performance with other codec types: 5a) GSM HR V 5b) EFR V 5c) HR AMR V 5d) AMR-WB	[27], [29] [27], [29] [27] [27]
6	Performance with additional channel conditions, for codecs used in the selection test: 6a) different C/I 6b) AGC variations V	[27] [27], [29]
7	Varying Channel Conditions	[27]
8	Performance with static jitter buffer (CSoHS, AoIP, and SIP-I services) V	[27]
9	Noisy Conditions	[27]
10	Erroneous Tone Detection	[27]

11	Gaps in transmission due to Handovers (both Inter-System and Intra-System)	[27]
12	Change of Speech Codec used due different channel conditions or to an Inter-System Handover	[27]
13	Sample Slip / Small Delay Variations at Handover	[27]
14	Combinations of Test Conditions: 14a) GSM HR and HR AMR with transcoding (G.729 / G.726) under different channel conditions 14b) CSoHS with transcoding (G.729 / G.726) and echo cancellation	[27]

5.1 Performance with dynamic jitter buffer

To compensate for packet delay variations in an IP-based transmission line, typically delay jitter buffers are employed. A static buffer has a fixed delay between input and output, whereas a dynamic jitter buffer can adapt its delay according to the statistics of the actual packet delays. The performance of the eCall modem in such a scenario was tested in the present test item. For the performance with a static jitter buffer, see clause 5.8.

The employed dynamic jitter buffer is speech frame based, i.e. if the delay is adapted, it will be extended/decreased always by one complete speech frame duration. It is bounded by minimum and maximum delays. On start, it has an initial default delay. The jitter buffer is driven by frame error rates (FER), i.e. delays will be adapted based on the resulting FER at the buffer output. This FER is determined over a number of e.g., 200 (relevant) speech frames. The actual procedure is detailed below.

The jitter buffer is parameterized by the following quantities, where the values used for the simulations are given in brackets:

1. Initial delay in speech frame durations (20 milliseconds): `N_BUFFER_DELAY_FRAMES` (=2).
2. Maximum jitter buffer delay: `JIT_BUF_DEL_MAX_FRAMES` (=5).
3. Minimum jitter buffer delay: `JIT_BUF_DEL_MIN_FRAMES` (=2).
4. Lower threshold of frame error rate (FER) for decreasing the jitter buffer delay: `FER_LO` (=0.005).
5. Upper threshold of frame error rate for increasing delay: `FER_HI`(=0.1).
6. Number of relevant cases (packets) the FER is averaged over: `FER_AVER_LEN` (=100).

Please note that all delays are measured relative to the minimal occurring delay in an actual system.

Packets which have not arrived after the maximum allowed buffer delay `JIT_BUF_DEL_MAX_FRAMES` are considered as unavoidable errors. They are not taken into account for calculating FER statistics. Therefore, the FER as considered here is the rate of avoidable errors rather than the total frame error rate.

The rules for jitter buffer adjustment can be briefly described as follows:

- When starting, the jitter buffer delay in speech frame durations is `N_BUFFER_DELAY_FRAMES`.
- The jitter buffer delay may be changed, i.e. increased or decreased only by the duration of one speech frame at a time.
- FER is averaged over a sliding window of the last `FER_AVER_LENGTH` relevant frames, where only those frames are considered to be relevant, that are delayed not more than `JIT_BUF_DEL_MAX_FRAMES` (that means, only avoidable errors are accounted for).
- In normal operation, the buffer delay may only be changed if since the previous delay change at least `FER_AVER_LENGTH` relevant frames were counted.
- Additionally, there is an early-increase feature for the buffer delay: If, before the collection of at least `FER_AVER_LENGTH` relevant frames it is sure that the buffer delay has to be increased afterwards, this increase will be done directly. With the actual parameterization `FER_HI` = 0.1 and `FER_AVER_LEN` = 200, this would mean that the jitter buffer delay is increased when `ErrorCount` = 21.

From the rules above follows also:

- The minimal time elapsing after a delay change and a following delay reduction is `FER_AVER_LEN`.
- The minimal time elapsing after a delay change and a following delay increase is `FER_AVER_LEN * FER_HI`.

Figure 2 shows the temporal evolution of the delay of the deployed jitter buffer (red) in channel profile #4 from Table 5, cf. [20]. The delays of the packets are shown in blue.

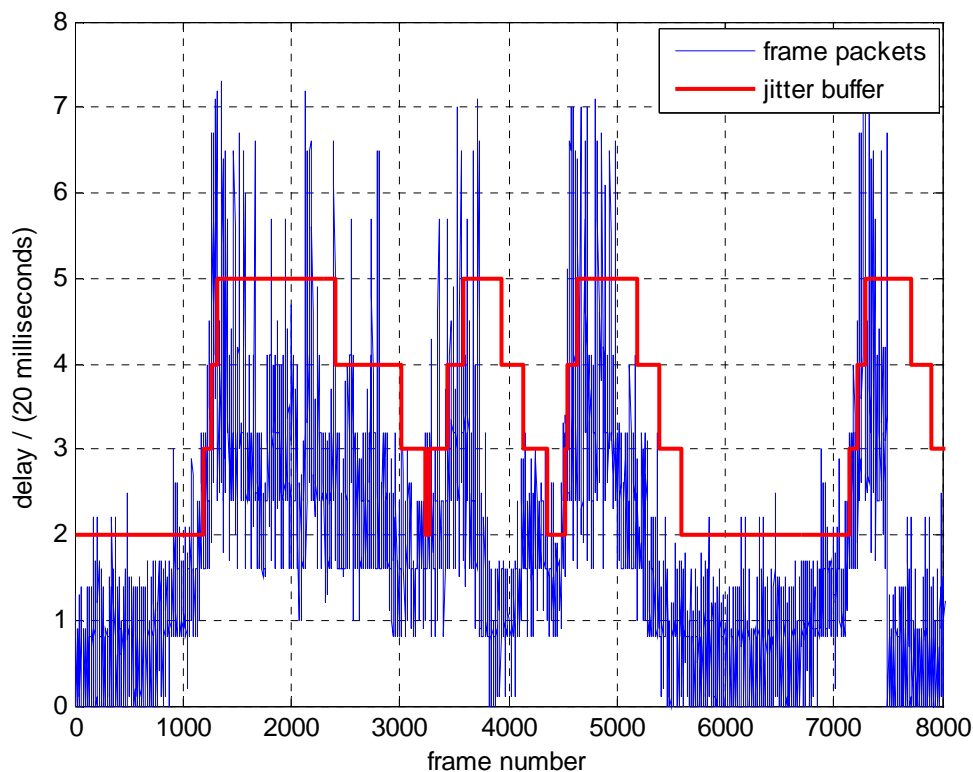

Figure 2: Packet delays (blue) and time varying delay of the adaptive jitter buffer (red) with the jitter buffer as described in this clause.

For the eCall characterization phase, adaptive jitter buffers (one on the uplink and one on the downlink) were integrated into the eCall simulation framework [7]. The jitter buffer delay may be expressed equivalently by the jitter buffer size (in speech frames), since incoming IP packets are stored for the duration of this additional delay. If a packet has not arrived at the end of this duration, it is considered to be lost. In this case, a loss concealment technique is applied, which synthesizes a signal replacing the missing packet. The packet loss concealment technique depends on the applied speech encoding scheme.

The eCall simulation framework was extended by a VoIP packetizer, a VoIP end-to-end channel simulator, and a VoIP de-packetizer including a static jitter buffer as described above. The VoIP packetizer converts the encoded speech frames to IP packets, where one compressed speech frame of 20 ms per IP packet is assumed, i.e. either one G.711 A-law [25] encoded 20ms speech frame or two encoded G.729 [13] 10 ms speech frames per IP packet. The VoIP channel is modelled by packet losses and varying individual packet delays based on delay and error profiles [20].

The jitter buffer integration in the test setup is illustrated in Figure 8 (see clause 5.8) for the case of the static jitter buffer. The setup is equivalent for the dynamic jitter buffer discussed in this clause.

Table 5a lists the different delay and error profiles used for IP jitter simulation. These profiles combine a large range of delay jitter characteristics with an additional packet loss probability. All six delay and error profiles were used for simulation with the G.711 [25] codec. All delay and error profiles in Tables 5a and 5b represent VoIP over the air channel conditions, typically exhibiting larger delay variations and higher packet loss rates than pure network VoIP conditions. Note that in all jitter buffer simulations, the starting point in the delay error profiles was selected randomly for each single MSD transmission.

The Figure of Merit for the selection test conditions over the dynamic jitter buffer profiles is given in Tables 5a and 5b as well. Table 5a contains the results for the original modem version, while Table 5b represents the updated modem version. Detailed average transmission times, as well as 95th percentiles per codec and C/I condition, are given in Tables C.1 – C.12 in Annex C.1.

Table 5a: Delay and error profiles [20] used for simulation, and Figure of Merit (original modem version [27])

Profile	Characteristics	Packet loss rate (%) (Total losses)	Figure of Merit (s)
1	Low-amplitude, static jitter characteristics, 1 frame/packet	0	4.58
2	Hi-amplitude, semi-static jitter characteristics, 1 frame/packet	0.24	7.31
3	Low/high/low amplitude, changing jitter, 1 frame/packet	0.51	8.88
4	Low/high/low/high, changing jitter, 1 frame/packet	2.4	11.83
5	Moderate jitter with occasional delay spikes, 2 frames/packet	5.9	12.44
6	Moderate jitter with severe delay spikes, 1 frame/packet	0.1	2.74

Table 5b: Delay and error profiles [20] used for simulation, and Figure of Merit (updated modem version [29])

Profile	Figure of Merit (s)
1	5.54
2	5.56
3	6.00
4	9.96
5	10.02
6	4.68

5.2 Performance with echo cancellation

For eCall verification purposes, an echo canceller (EC) has been integrated into the IVS and PSAP modems. In this setup, the respective input and original modem output signals represent the two input signals for the echo canceller, whose output signal defines the modem output signal transmitted on uplink and downlink.

In the algorithm used for echo cancellation, a normalized Least-Mean-Square (NLMS) algorithm is employed for adaptive filtering in order to obtain the acoustic/network coupling and to generate an estimate of the echo. This estimated echo is subtracted from the echo corrupted signal and the echo cleaned signal is transmitted to the listener at the other end, thereby achieving echo-free full-duplex communication.

The main parameter of the echo canceller to tune is the length of the filter. At a sampling rate of 8 kHz, the filter length was originally set to 64 samples, relating to a filter window of 8 milliseconds. For additional tests, the filter length was further increased to 160 samples (20 ms).

The performance with echo cancellation was tested in the simulation framework used for selection testing, and for the unordered test campaign file which contains 2600 test cases in total. According to the eCall Selection Test Plan, the signal paths in both uplink and downlink of the simulation chain include two independent delays, each uniformly distributed between 10 and 30 milliseconds. In order to assess different relations of filter length to delay ranges, all uplink and downlink delays of the selection test campaign have further been divided by either a factor of 6 or 15.

Performance results are shown in Table 6.

Table 6: Performance with echo cancellation

Channel delay factor	EC filter length	MSD transmission time over 2600 test cases (selection test campaign)	
		Average (FoM)	95 th percentile
1	64 samples	2.03 s	3.48 s
1/15	64 samples	2.03 s	3.72 s
1/6	160 samples	2.00 s	3.44 s

As a conclusion, in all three cases no significant impact of the echo canceller on the modem performance is observed. The Figure of Merit (FoM) is slightly above 2 seconds and therefore preserves the statistical performance as without echo cancellation.

The results in this clause were generated with a prototype version of the eCall modem used in the selection tests. The performance of the specified reference modem implementation [7] is expected to be very similar to the given figures.

5.3 Performance with transcoding

The simulation framework as used for selection testing already includes a form of audio impairment in uplink and downlink, prior to and after PSAP processing: ITU-T G.711 A-Law [25] compression and expansion.

To assess the performance of the eCall modem versions with other transcoding scenarios, two different configurations are considered:

1) The tandem operation of:

- a) ITU-T G.726 Adaptive Differential Pulse Code Modulation (ADPCM) transcoding [12] at 32 kbit/s, operating on ITU-T G.711 A-law [25] compressed speech samples as specified;
- b) one of the complete set of speech codecs used in the selection test (see e.g. Table 1);

or

2) the tandem operation of:

- a) ITU-T G.729 A/B transcoding by conjugate-structure algebraic-code-excited linear prediction (CS-ACELP) [13] at 8 kbit/s, where "A/B" indicates one of the following G.729 variants:
 - i) ITU-T G.729 Annex A, i.e., the reduced-complexity version of the baseline G.729 codec;
 - ii) ITU-T G.729 Annex B, i.e., the baseline G.729 codec additionally employing a VAD module;
 - iii) ITU-T G.729 Annex B based on Annex A, i.e., the reduced-complexity version of the baseline G.729 codec, additionally employing a VAD module;
- b) one of the complete set of speech codecs used in the selection test.

The two different transcoding configurations are illustrated in Figures 3 and 4, respectively.

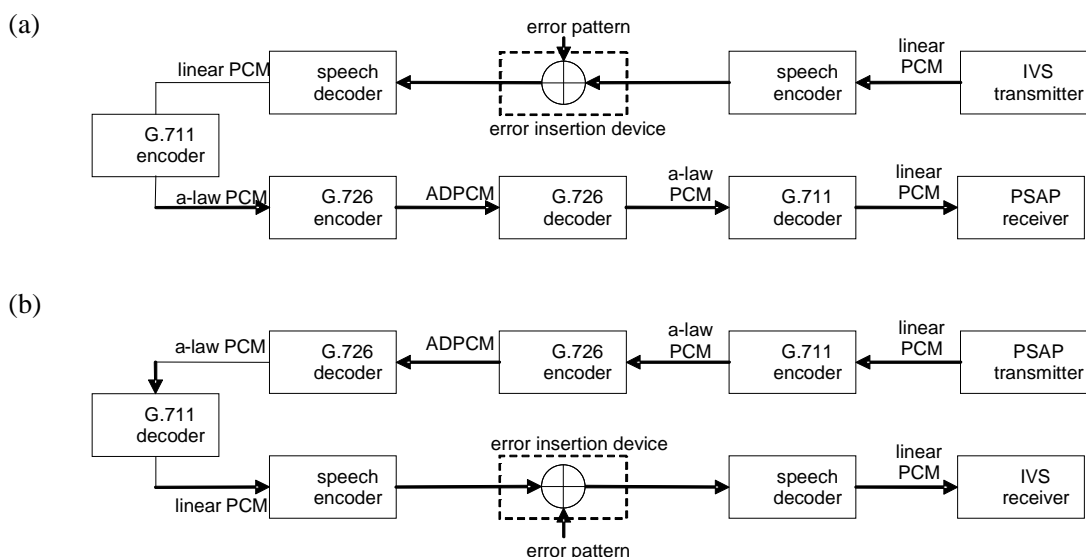

**Figure 3: Transcoding configuration 1: G.711 & G.726 and mobile radio network codec:
(a) uplink; (b) downlink**

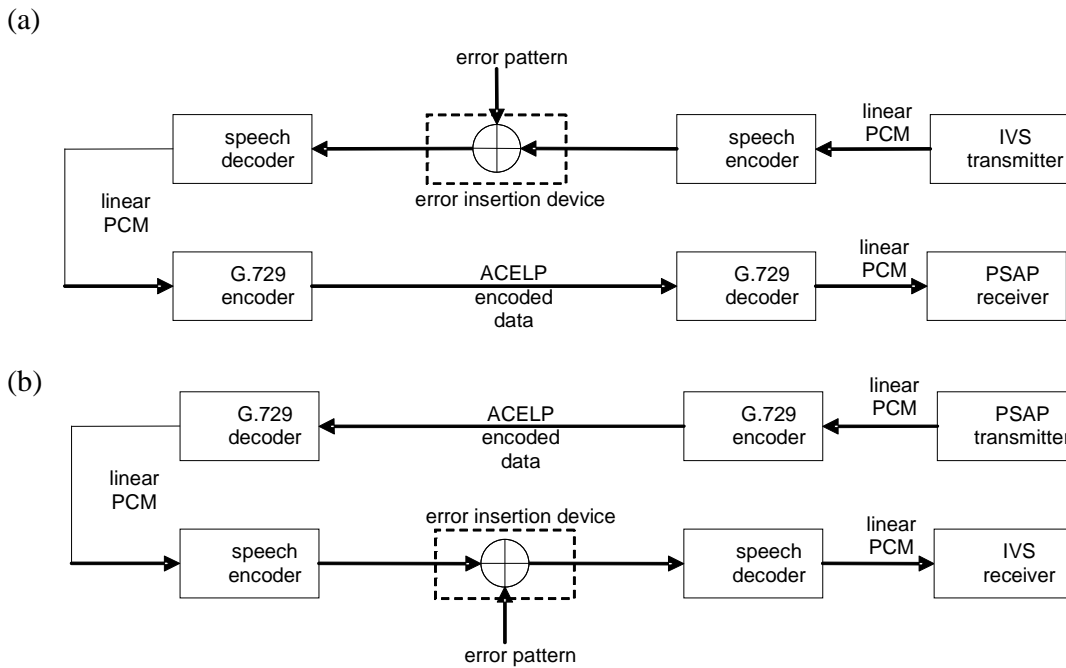

Figure 4: Transcoding configuration 2: G.729 and mobile radio network codec: (a) uplink; (b) downlink

5.3.1 Performance with ITU-T G.711&G.726 transcoding

In the present clause, the eCall modem performance is tested for cases where the speech frames are transcoded according to ITU-T G.726 [12]. The G.726 speech codec standard is an adaptive differential pulse code modulation scheme (ADPCM) covering the transmission of voice at rates of 16, 24, 32, and 40 kbit/s. For the eCall verification purposes, the most commonly used mode with a data rate of 32 kbit/s is applied. G.726 operates on 64 kbit/s A-law or μ -law PCM data. Nevertheless, in the ADPCM encoder the first operation is the conversion of the A-law or μ -law PCM input signal to uniform PCM. G.711 A-law compresses each 320 byte speech frame to a size of 160 byte. The 160 byte A-law speech frame is compressed by G.726 to 80 byte of ADPCM encoded data.

To assess the performance with G.726 transcoding, the A-law compressed PCM data is G.726 encoded, and then again G.726 decoded and afterwards G.711 A-law decoded (see Figure 1). The implementation of the G.726 codec included to the eCall simulation framework is based on the ITU reference code. The figure of merit obtained with G.726 transcoding is included in Table 7a.

5.3.2 Performance with ITU-T G.729 A/B transcoding

To assess the performance with ITU-T G.729 A/B transcoding, G.711&G.726 processing was replaced by G.729 A/B coding [13] with 8.0 kbit/s as output data rate. The G.729 codec was used in both uplink and downlink (see Figure 2). All performance results are shown in Tables 7a and 7b.

Table 7a: Figures of merit with G.711&G.726 or G.729 transcoding (original modem version [27])

Codec	Figure of Merit	95 th percentile
no transcoding	2.03 s	3.54 s
G.711&G.726	2.11 s	3.88 s
G.729 Annex A	3.22 s	6.40 s
G.729 Annex B	3.21 s	6.40 s
G.729 Annex B based on Annex A	3.23 s	6.40 s

Table 7b: Figures of merit with G.729 transcoding (updated modem version [29])

Codec	Figure of Merit	95 th percentile
no transcoding	2.28 s	4.16 s
G.729 Annex B based on Annex A	3.72 s	7.26 s

It can be concluded that the two studied transcoding scenarios do not lead to a significant impairment of the average MSD transmission times.

Detailed average MSD transmission times, as well as 95th percentiles per codec and C/I condition, are given in Tables C.13 – C.22 in Annex C.2.

5.4 Performance with packet loss concealment techniques

Transmission of speech packets over the packet-switched IP network is tested, where a certain percentage of the IP packets is lost randomly (but no jitter is introduced). Lost packets are replaced by concealment techniques specific for the respective compression scheme. The concealment mechanisms of ITU-T G.711 A-law [25] compression and G.729 [13] transcoding are tested. The two test configurations are illustrated in Figures 5 and 6, respectively.

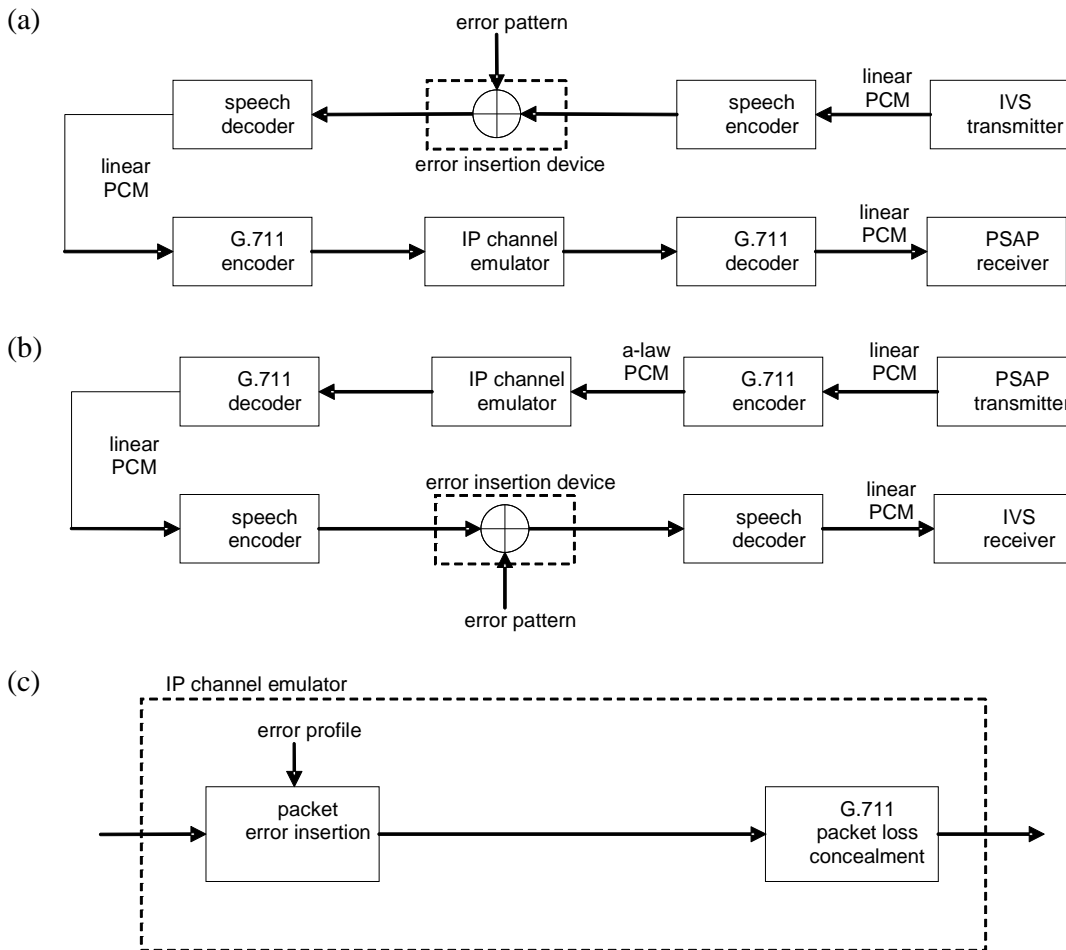

Figure 5: Packet loss concealment configuration for G.711: (a) uplink; (b) downlink; (c) configuration of IP channel emulator for this test case

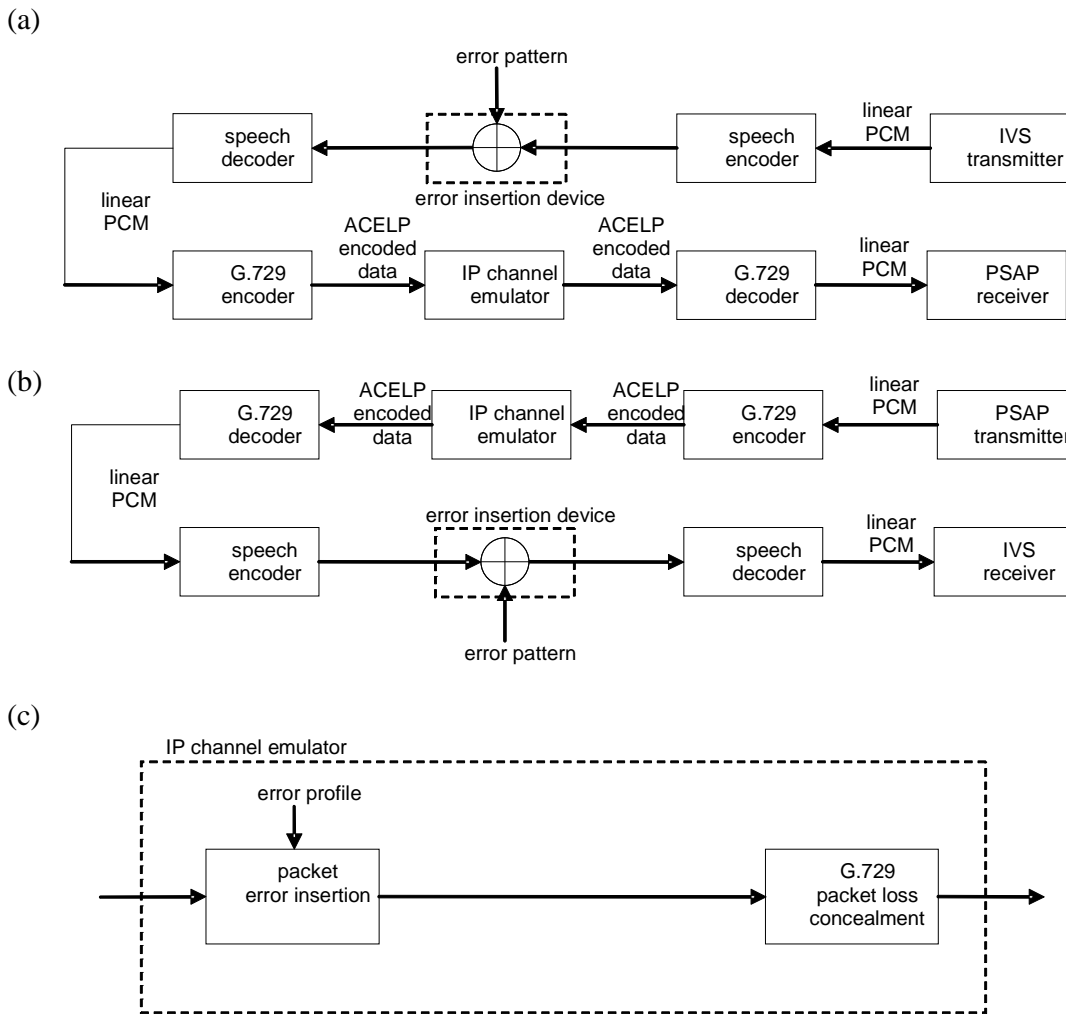

Figure 6: Packet loss concealment configuration for G.729:
(a) uplink; (b) downlink; (c) configuration of IP channel emulator for this test case

The performance testing of the modem versions when statistically independent frame losses occur is very similar to the performance testing with jitter buffers, which is treated in clause 5.8. Here, packets are erased randomly with a certain loss probability. Then, the same packet loss concealment techniques as described in clause 5.8 are applied. In the simulations loss probabilities of 1 % and 10 % are tested. Again, packet loss concealment techniques for both G.711 and G.729 A/B were tested, the respective results are shown in Table 8.

Please note that in all random packet loss simulations the seed of the random generator is derived from the system clock time prior to the transmission of every MSD.

Table 8: Figure of merit for packet loss concealment with transcoding

Transcoding; Loss probability	Figure of Merit	95 th percentile
ITU-T G.711; 1 %	2.11 s	3.90 s
ITU-T G.711; 10 %	2.73 s	4.60 s
ITU-T G.729 Annex B based on Annex A; 1 %	3.35 s	6.40 s
ITU-T G.729 Annex B based on Annex A; 10 %	4.88 s	8.92 s

5.5 Performance with other codec types

5.5.1 GSM HR

To test the modem's performance over GSM HR speech channels, the ETSI GSM HR source code version including channel coding and decoding [14] was used. This special version of the code also includes an Error Insertion Device (EID) in source code form (MAPEID3 .C). Both speech codec and EID were integrated into the eCall modem test setup. It was ensured (by checking the bit-exactness of the output of the encoder-decoder chain) that the special version of the GSM HR codec is identical in its speech coding and decoding function to the official GSM HR standard [15].

Suitable channel error patterns for this version of the GSM HR codec are also available from ETSI [16] for the channel conditions C/I = 4, 7, and 10 dB. The channel error patterns can then be directly used in the simulation framework.

Tables 9a and 9b show transmission time results for the GSM HR, obtained based on the ETSI error patterns of 8 seconds duration, and for the error-free case. For each channel condition all 160 possible delays were taken into account, i.e. 160 MSD messages were transmitted. The error patterns were used in a cyclic way. No transmission failures (according to the definition in clause 4.1.1) occurred.

Table 9a: MSD transmission times with GSM HR in different channel conditions (original modem version [27])

Channel condition	Average	95 th percentile
C/I=4 dB	21.26 s	37.78 s
C/I=7 dB	10.68 s	16.52 s
C/I=10 dB	7.67 s	8.92 s
Error free	6.48 s	8.22 s

Table 9b: MSD transmission times with GSM HR in different channel conditions (updated modem version [29])

Channel condition	Average	95 th percentile
C/I=4 dB	24.02 s	43.40 s
C/I=7 dB	13.10 s	22.78 s
C/I=10 dB	9.34 s	16.84 s
Error free	7.86 s	16.02 s

The results show that with GSM-HR, significantly increased MSD transmission times can occur depending on the channel condition. Although the MSD is eventually successfully transmitted even in bad channels, the use of GSM-HR should be avoided for eCall emergency data transmission if possible.

5.5.2 GSM EFR

The GSM EFR [22] source code (V8.0.1) was taken from [17], and the original EFR bit mapper was modified to be compliant with the extended IF1 bitstream format. Static error patterns used during the EFR selection phase [18] were converted using the corresponding EID (error insertion device) [19] into residual bit errors and/or packet losses, to form extended IF1 error patterns for eCall. The EFR error patterns are different from those for AMR 12.2 since the channel coding is different for the EFR and AMR speech channels. Finally, the eCall test setup [7] was used to test the following EFR conditions, as shown in Table 10.

Table 10: Tested channel conditions for EFR and AMR 12.2

Codec Type	EFR	AMR
Codec Mode Radio condition	12.2	12.2
C/I = 1 dB	X	
C/I = 4 dB	X	
C/I = 7 dB	X	X
C/I = 10 dB	X	X
C/I = 13 dB	X	X
C/I = 16 dB	X	
error free	X	X

For information the residual bit error rate (RBER) and frame error rate (FER) for the EFR error patterns are given below in Table 11. It should be noted that the error rates for AMR and EFR are not directly comparable since the underlying error patterns were generated in different link-level simulations.

Table 11: RBER and FER statistics for the EFR and AMR error patterns

Error Pattern	Statistics for EFR error pattern		Statistics for AMR12.2 error pattern	
	RBER (%)	FER (%)	RBER (%)	FER (%)
C/I = 1 dB	16.7	65.5	-	-
C/I = 4 dB	5.98	21.8	-	-
C/I = 7 dB	2.31	4.02	2.78	7.68
C/I = 10 dB	1.05	0.19	1.00	1.57
C/I = 13 dB	0.47	0	0.18	0.10
C/I = 16 dB	0.18	0	-	-

EFR transmission time results for the eCall modem can be found in Tables 12a and 12b (for comparison, those AMR 12.2 results have been added to Table 12a that were tested in the selection phase). The performance is not affected in good or error-free channel conditions. 98% of MSD transmissions over EFR succeeded in the C/I=1dB condition; in all other conditions, the MSD transmissions were 100% successful.

Table 12a: Performance of eCall modem with EFR and AMR 12.2: average MSD transmission times and 95% confidence intervals (original modem version [27])

Channel condition	AMR12.2*		EFR12.2	
	Average	95 th perc.	Average	95 th perc.
C/I=1 dB			46.55	110.2
C/I=4 dB			2.73	4.82
C/I=7 dB	1.92	2.08	1.66	1.74
C/I=10 dB	1.49	1.74	1.36	1.36
C/I=13 dB	1.36	1.36	1.35	1.35
C/I=16 dB			1.35	1.36
Error free	1.36	1.36	1.35	1.36

*: Since a different simulation campaign file was used, the results for AMR 12.2 are slightly different compared to Table 1.

Table 12b: Performance of eCall modem with EFR and AMR 12.2: average MSD transmission times and 95% confidence intervals (updated modem version [29])

Channel condition	EFR12.2	
	Average	95 th perc.
C/I=4 dB	3.41	5.32
C/I=7 dB	2.04	2.40
C/I=10 dB	1.65	1.98
Error free	1.51	1.52

Despite differences in channel coding, the performance of the eCall inband modem with AMR 12.2 and GSM EFR is quite similar for high C/I; some divergence can be observed at low C/I.

5.5.3 HR AMR

The HR AMR employs the same speech codecs than the FR AMR [23], but only the six lowest modes (4.75 up to 7.95 kbit/s). The channel coding is however much weaker so that the encoded data can be transmitted within a half-rate channel of 11.4 kbit/s.

In the eCall test setup framework, the HR AMR performance can be analyzed by only replacing the error patterns and leaving the originally implemented AMR speech codec unchanged. Residual error patterns in IF1 format were generated by link-level simulations of the HR AMR speech transmission. These patterns are of duration 600 s. The

channel conditions were taken from the set $C/I = 4, 7, \text{ and } 10$ dB. It should be noted that for error-free channels, the results are identical to those presented for the AMR full rate channel (see Table 1), since the channel coding does not have any effect in this case.

For the HR AMR channels, a total of 1800 test cases were simulated, 100 for each combination of codec mode and C/I value. Table 13 comprises results obtained with the eCall modem. The overall figure of merit is 4.7049 seconds, no timeouts occurred.

Table 13: MSD transmission times in s for HR AMR individually per codec mode and C/I value

	$C/I = 4$ dB		$C/I = 7$ dB		$C/I = 10$ dB		error-free	
	average	95 th perc.	average	95 th perc.	average	95 th perc.	average	maximum
AHS 7.95	7.83	17.00	4.23	10.82	2.45	4.08	1.49	1.68
AHS 7.40	5.94	12.70	3.74	11.36	2.36	4.44	1.50	1.68
AHS 6.70	7.71	17.00	4.43	9.10	2.80	4.06	1.85	2.04
AHS 5.90	7.31	15.00	4.43	7.64	2.82	4.06	2.04	2.40
AHS 5.15	8.42	16.92	5.13	8.72	3.95	5.66	2.48	3.80
AHS 4.75	8.67	16.42	5.76	8.72	4.03	4.98	3.10	3.80

The results show that the employment of HR AMR channels can lead to slightly increased MSD transmission times, but these increases are not severe.

5.5.4 AMR-WB

The eCall test setup described in [8] was run on a single computer. Since AMR-WB [24] operates at a sampling frequency of 16 kHz, it was necessary to adapt the eCall emitted and received signals (with sampling frequency of 8 kHz). The input/output of the AMR-WB codecs were therefore modified to include a resampling operation. A 58-order symmetric FIR filter with 59 coefficients was designed with cut off frequency near half-band. The frequency response of this filter is illustrated in Figure 7.

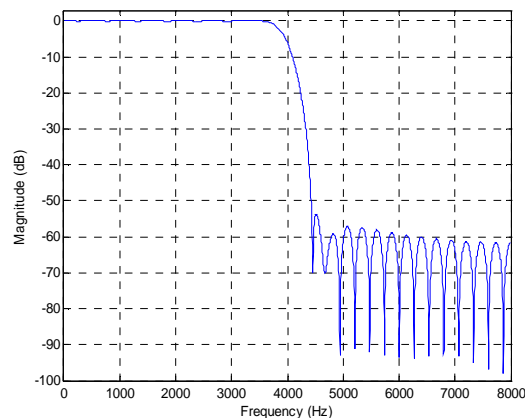

Figure 7: Frequency response of half-band filter

The upsampling and downsampling operations were implemented in the standard way (zero insertion-filtering and filtering-interleaved sample selection, respectively). Note that there are four possible polyphase combinations for the entire resampling operations (even/even, even/odd, odd/even, odd/odd samples). It was verified that the results are equivalent in all four cases, so only one combination will be used for the entire tests with AMR-WB.

The employed error patterns for AMR-WB at 6.6, 8.85 and 12.65 kbit/s on GSM channels for $C/I=4, 7, 10, 13, 16$ and in the error-free case include 29,999 frames with the AMR-WB bitstream frame (hard bits) followed by a bad frame indicator. They were converted to the extended IF1 format used in [8]. No error patterns were available to test higher AMR-WB modes in channel error conditions. Therefore all modes above 12.65 kbit/s were tested in the error-free case. The FER and residual BER for the different AMR-WB rates and C/I values are shown in Table 14.

Table 14: FER/BER for AMR-WB error patterns

AMR-WB mode	C/I (dB)	FER (%)	BER (%)
6.60	19	0.17	0.04
	16	0.69	0.16
	13	2.40	0.61
	10	6.51	1.85
	7	14.26	4.39
	4	27.05	8.84
8.85	19	0.25	0.07
	16	1.01	0.27
	13	3.22	0.91
	10	7.93	2.38
	7	16.60	5.31
	4	30.17	10.23
12.65	19	0.63	0.14
	16	1.95	0.46
	13	5.37	1.34
	10	11.87	3.17
	7	22.69	6.55
	4	38.23	11.77

The AMR-WB codec was modified in order to use Windows pipes instead of input/output files. It was also necessary to adapt the bitstream format to the extended IF1 format used in the eCall test setup [26]. The unused "13" frame type was used for the eCall test setup to recognize AMR-WB bitstreams. The AMR-WB mode was passed into the 5 spare bits in the mode indication.

Performance results with AMR-WB are shown in Tables 15 and 16. Note that the MSD transmission was successful in 100% of the tests.

Table 15: MSD transmission times (in s) for AMR-WB in the error-free case

MSD transmission time	AMR-WB mode (kb/s)								
	23.85	23.05	19.85	18.25	15.85	14.25	12.65	8.85	6.60
Average	1.36	1.36	1.36	1.36	1.36	1.36	1.36	1.36	1.73
95th perc.	1.38	1.38	1.38	1.38	1.38	1.38	1.36	1.38	1.76
Maximum	1.38	1.38	1.38	1.38	1.38	1.38	1.38	1.38	1.76

Table 16: MSD transmission times (in s) for AMR-WB

Channel condition, radio modulation	MSD transmission time	AMR-WB mode (kb/s)		
		12.65	8.85	6.60
C/I=19dB GMSK	Average	1.36	1.38	1.74
	95th perc.	1.38	1.38	1.76
	Maximum	1.72	2.98	2.08
C/I=16dB GMSK	Average	1.44	1.50	1.75
	95th perc.	1.74	1.76	1.76
	Maximum	2.96	2.98	2.08
C/I=13dB GMSK	Average	1.55	1.55	1.83
	95th perc.	2.08	2.1	2.08
	Maximum	3.76	3.36	3.34
C/I=10dB GMSK	Average	2.04	1.85	2.10
	95th perc.	3.36	2.98	3.36
	Maximum	13.56	4.54	4.84
C/I=7dB GMSK	Average	2.64	2.44	2.54
	95th perc.	4.56	4.44	4.04
	Maximum	13.44	6.56	15.72
C/I=4dB	Average	5.31	4.60	4.60

GMSK	95th perc.	13.68	9.44	9.4
	Maximum	25.32	39.74	19.54

The 95th percentiles presented in Tables 15 and 16 is the time that is exceeded by only 5% of measured transmission times.

From Tables 15 and 16 it appears that the MSD transmission time is below 4s, except the C/I=4 dB case.

5.6 Performance with additional channel conditions

5.6.1 Different C/I

A number of additional conditions to be tested are reproduced in Table 17. "X" shows conditions included in the selection test plan. "#" and "(#)" shows additional operating conditions that should be evaluated, where the conditions indicated by "(#)" represent better channel conditions than those tested in the selection. All radio conditions except the error-free case are represented by error patterns in the test framework. Therefore, this verification item relies on the availability of suitable error patterns.

Table 17: Additional codec and channel conditions for eCall evaluation

Codec Type	GSM FR	FR AMR							
Codec Mode	13.0	12.2	10.2	7.95	7.4	6.7	5.9	5.15	4.75
Radio condition									
C/I = 1 dB							#	#	X
C/I = 4 dB					#	#	X	X	X
C/I = 7 dB	X	X	X	X	X	X	X	X	X
C/I = 10 dB	X	X	X	X	X	(#)	(#)	(#)	(#)
C/I = 13 dB	X	X	X	(#)	(#)	(#)	(#)		
C/I = 16 dB	X	(#)	(#)						
error free	X	X	(#)	(#)	(#)	(#)	(#)	(#)	(#)
RSSI = -100 dBm	X								X
RSSI = -95 dBm	(#)	#							(#)
RSSI = -90 dBm	(#)	#							(#)

For the error-free test conditions (indicated by bold face in Table 17), a verification has been carried out. The following results have been derived:

Table 18: MSD transmission times for tested speech codecs in error-free conditions

Codec (error free)	Average MSD transmission time	Maximum MSD transmission time
FR	1.33 s	1.66 s
AMR 12.2	1.33 s	1.34 s
AMR 10.2	1.33 s	1.34 s
AMR 7.95	1.49 s	1.68 s
AMR 7.4	1.50 s	1.68 s
AMR 6.7	1.85 s	2.04 s
AMR 5.9	2.04 s	2.40 s
AMR 5.15	2.48 s	3.80 s
AMR 4.75	3.10 s	3.80 s

Table 19 contains the average MSD transmission times for the other additional test conditions from Table 17.

Table 19: Average MSD transmission times (in s) for additional test conditions

	GSM FR	FR AMR							
	13.0	12.2	10.2	7.95	7.4	6.7	5.9	5.15	4.75
C/I = 1dB	-	-	-	-	-	-	2.78	3.45	-
C/I = 4dB	-	-	-	-	1.99	2.11	-	-	-
C/I = 7dB	-	-	-	-	-	-	-	-	-
C/I = 10dB	-	-	-	-	-	1.91	2.10	2.55	3.09
C/I = 13dB	-	-	-	1.51	1.48	1.81	2.10	-	-
C/I = 16dB	-	1.40	1.39	-	-	-	-	-	-
RSSI = -95dBm	1.54	1.43	-	-	-	-	-	-	3.16
RSSI = -90dBm	1.53	1.47	-	-	-	-	-	-	3.10

For information, Table 20 summarizes the average transmission times for all the codec and C/I combinations that have been studied in the selection and verification/characterization tests.

Table 20a: Average MSD transmission times (in s) for all studied test conditions (original modem version [27])

	GSM FR	FR AMR							
	13.0	12.2	10.2	7.95	7.4	6.7	5.9	5.15	4.75
C/I = 1dB	-	-	-	-	-	-	2.78	3.45	4.07
C/I = 4dB	-	-	-	-	1.99	2.11	2.41	3.10	3.38
C/I = 7dB	2.29	1.91	1.80	1.69	1.68	2.01	2.10	2.57	3.12
C/I = 10dB	1.66	1.53	1.42	1.56	1.59	1.91	2.10	2.55	3.09
C/I = 13dB	1.45	1.36	1.36	1.51	1.48	1.81	2.10	-	-
C/I = 16dB	1.39	1.40	1.39	-	-	-	-	-	-
RSSI = -100dBm	1.50	-	-	-	-	-	-	-	-
RSSI = -95dBm	1.54	1.43	-	-	-	-	-	-	3.16
RSSI = -90dBm	1.53	1.47	-	-	-	-	-	-	3.10
error free	1.33	1.33	1.33	1.49	1.50	1.85	2.04	2.48	3.10

Table 20b: Average MSD transmission times (in s) for all studied test conditions (updated modem version [29])

	GSM FR	FR AMR							
	13.0	12.2	10.2	7.95	7.4	6.7	5.9	5.15	4.75
C/I = 1dB									4.56
C/I = 4dB							3.54	3.54	3.65
C/I = 7dB	2.51	2.34	2.40	1.95	1.94	2.40	2.41	2.91	3.39
C/I = 10dB	1.90	1.73	1.98	1.74	1.77				
C/I = 13dB	1.60	1.53	1.52						
C/I = 16dB	1.59								
RSSI = -100dBm	1.68								
error free	1.52	1.51							3.41

5.6.2 AGC variations

To assess the impact of a possibly misadjusted automatic gain control (AGC) or other linear scaling due to transmission over analogue telephone lines, the input signals to the IVS and PSAP receivers are multiplied with constant gain factors and then mapped again on PCM values. Signal amplitudes exceeding the 16-bit PCM range are clipped. Simulations have been carried out with gain factors in the range from -27 dB to +30 dB. Tables 21a and 21b comprise the respective figures of merit and the numbers of timeouts.

Table 21a: Figure of merit and number of timeouts for different AGC scaling factors (original modem version [27])

Gain	Amplitude scaling factor	Figure of merit / seconds	95 th percentile (timeout)	Fraction of timeouts
-27 dB	0.0442	14.8764	(timeout)	143/2600
-24 dB	0.0625	3.3807	4.60	8/2600
-18 dB	0.125	2.0455	3.52	0
-12 dB	0.25	1.9872	3.52	0

-9 dB	0.3534	2.0063	3.52	0
-6 dB	0.5	2.0173	3.52	0
-3 dB	0.7071	2.0271	3.54	0
+3 dB	1.4142	2.0350	3.52	0
+6 dB	2.0	2.0373	3.54	0
+12 dB	4.0	2.2603	4.60	0
+18 dB	8.0	3.7205	13.06	0
+24 dB	16	5.5379	14.46	0
+30 dB	32	7.0306	17.88	0

Table 21b: Figure of merit and number of timeouts for different AGC scaling factors (updated modem version [29])

Gain	Amplitude scaling factor	Figure of merit / seconds	95 th percentile	Fraction of timeouts
-27 dB	0.0442	21.0611	(timeout)	219/2600
-24 dB	0.0625	3.9133	5.48	10/2600
-18 dB	0.125	2.2943	3.72	0
-12 dB	0.25	2.2236	4.14	0
-9 dB	0.3534	2.2508	4.16	0
-6 dB	0.5	2.2671	4.16	0
-3 dB	0.7071	2.2744	4.16	0
+3 dB	1.4142	2.2804	4.16	0
+6 dB	2.0	2.2800	4.16	0
+12 dB	4.0	2.5643	5.04	0
+18 dB	8.0	4.3168	15.28	0
+24 dB	16	9.0589	18.38	0
+30 dB	32	13.1571	27.24	2/2600

The eCall modem is very robust against both up- and downscaling. For gains in the range from -18 dB to +24 dB, no transmission failures occurred.

5.7 Varying channel conditions

5.7.1 Description of test setup

The eCall test setup described in [2] was run on a single computer. The main change compared to [2] was the creation of new error patterns to represent typical varying channel conditions. The generated error patterns are listed in Table 22. There are 8 varying conditions for the AMR codec (one for each mode), one varying condition for the GSM FR codec, and one varying condition for the GSM EFR codec. A time period of 400ms was selected for channel adaptation. This figure of 400 ms describes reasonably well slow channel fading and allows changing channel conditions several times during one eCall data transfer (<4s). The C/I is decreased until the worst channel conditions are reached, then increased until the best channel conditions, and so on. The C/I values were those used during eCall verification tests; consequently the error patterns for varying channel conditions were created by extracting 400ms segments of fixed-channel error patterns. It is worth recalling that the test setup in [2] uses error patterns by starting at a random location, therefore the C/I starting point is selected randomly.

Table 22: C/I patterns used to create varying channel conditions.

Codec type	Varying C/I pattern (change period: 400ms)
AMR@4.75kb/s	C/I = ∞→7dB→4dB→1dB→1dB→4dB→7dB→∞→∞→7dB→...
AMR@5.15kb/s	C/I = ∞→7dB→4dB→4dB→7dB→∞→∞→7dB→...
AMR@5.90kb/s	C/I = ∞→7dB→4dB→4dB→7dB→∞→∞→7dB→...
AMR@6.70kb/s	C/I = ∞→7dB→7dB→∞→∞→7dB→...
AMR@7.40kb/s	C/I = ∞→10dB→7dB→7dB→10dB→∞→∞→10dB→...
AMR@7.95kb/s	C/I = ∞→10dB→7dB→7dB→10dB→∞→∞→10dB→...
AMR@10.2kb/s	C/I = ∞→13dB→10dB→7dB→7dB→10dB→13dB→∞→∞→13dB→...
AMR@12.2kb/s	C/I = ∞→13dB→10dB→7dB→7dB→10dB→13dB→∞→∞→13dB→...
FR	∞→16dB→13dB→10dB→7dB→7dB→10dB→13dB→16dB→∞→∞→16dB→...
EFR	∞→16dB→13dB→10dB→7dB→4dB→4dB→7dB→10dB→13dB→16dB→∞→∞→13dB→...

5.7.2 Test results

For each test condition, 100 transmissions were simulated by using a random delay between 10 and 30 ms. The test results are showed in Table 23. All MSD transmissions were successful.

Table 23: MSD transmission times (in s) for varying channel conditions.

Codec	MSD transmission time		
	Average	95th perc.	Maximum
GSM_FR	1.63	2.08	2.96
EFR	1.57	2.08	2.08
AMR 12.2	1.53	1.74	2.08
AMR 10.2	1.5	1.74	2.96
AMR 7.95	1.62	1.74	2.08
AMR 7.4	1.63	1.74	1.76
AMR 6.7	1.95	2.08	2.1
AMR 5.9	2.18	2.44	2.44
AMR 5.15	2.75	3.18	3.52
AMR 4.75	3.42	3.92	4.24

This table shows that the average transmission times with varying channel conditions are below 4s. The changing error patterns do not have a significant impact transmission times. In comparison to results with fixed C/I (verification phase), it seems that a varying channel behaves like a fixed C/I channel, the value of this 'virtual' C/I is somewhere between the lowest C/I and the highest C/I used in error pattern creation.

During the test, there were 4 test cases (all in AMR@4.75kb/s mode) where 4s was exceeded. The maximum transmission time in these cases is 4.24s. This was already observed during verification phase, when testing AMR@4.75kb/s with C/I=1dB.

5.8 Performance with static jitter buffer

In this clause, scenarios are considered where the 112 emergency call is routed from the RNC/BSC over the packet-switched IP network to the PSAP. In packet-switched systems the end-to-end delay of packets can vary depending upon both channel conditions and network load. This variance in end-to-end delay, commonly termed *jitter*, leads to an irregular arrival of data packets at the gateway. Even out-of-order arrival may occur. Since the speech decoder requires data packets at fixed intervals, de-jitter techniques are applied, which incorporate a jitter buffer as an essential element. The amount of jitter which can be compensated is limited by the size of the jitter buffer. Data packets with a delay exceeding the buffer size cannot be forwarded at the adequate time and have to be discarded.

Typically, the PCM data is compressed before it is packetized. Here, two different compression schemes are considered: Simple G.711 A-law companding and G.729 encoding. The respective test configurations are illustrated in Figures 8 and 9.

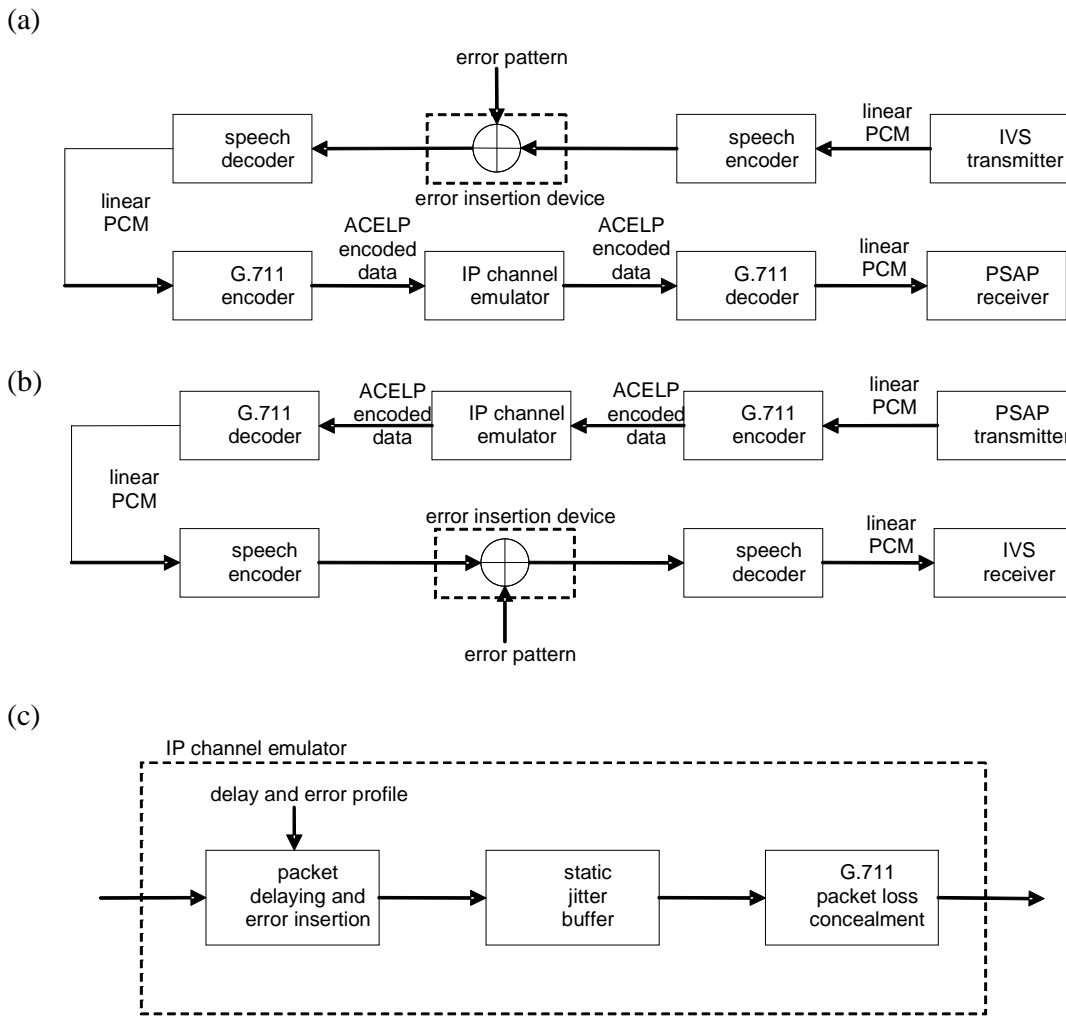

Figure 8: Static jitter buffer configuration with G.711:
(a) uplink; (b) downlink; (c) configuration of IP channel emulator for this test case

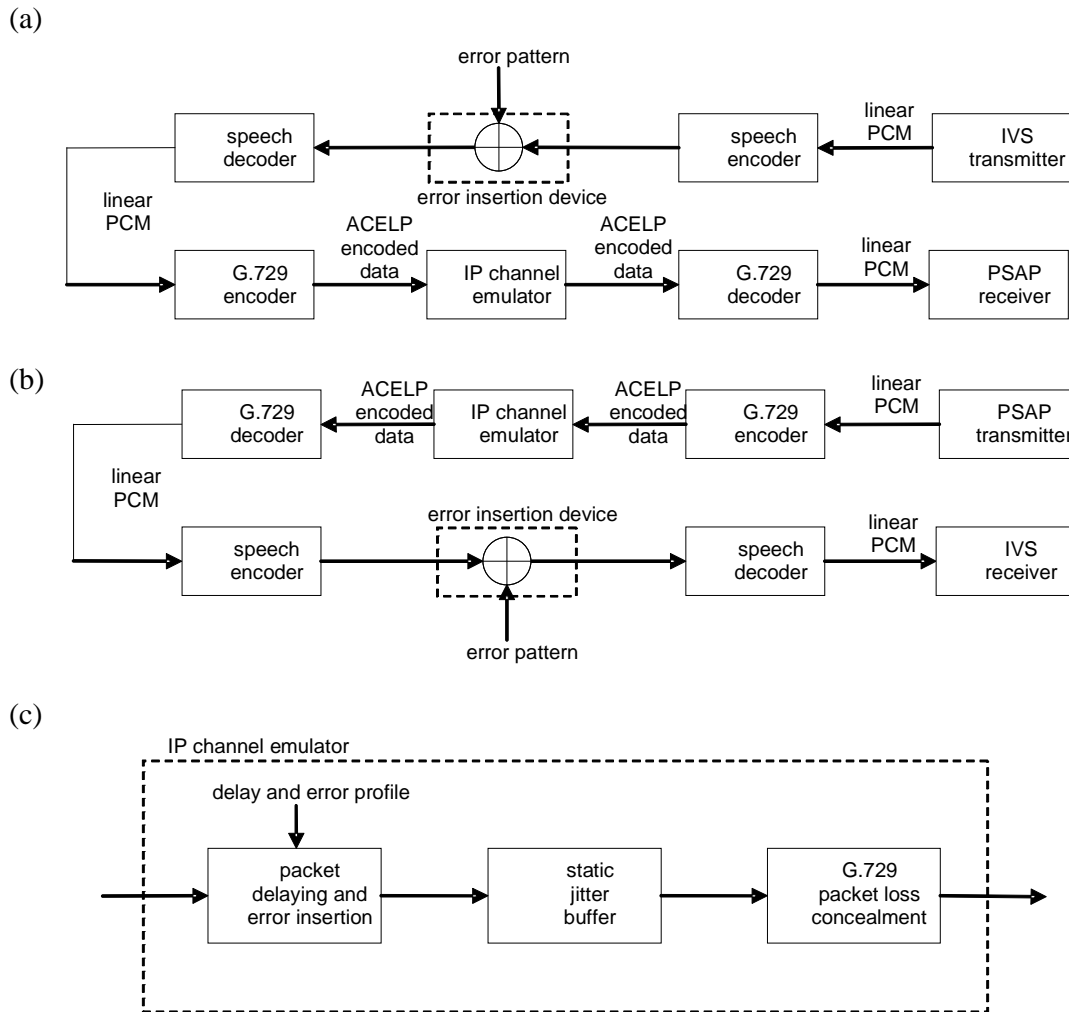

Figure 9: Static jitter buffer configuration with G.729:
(a) uplink; (b) downlink; (c) configuration of IP channel emulator for this test case

5.8.1 Simulation Methodology

For eCall verification purposes, jitter buffers with fixed, i.e. adjustable but not adaptive delays were integrated into the simulation framework [7]. The jitter buffer delay may be expressed equivalently by the jitter buffer size (in speech frames), since incoming IP packets are stored for the duration of this additional delay. If a packet has not arrived at the end of this duration, it is considered to be lost. In this case, a loss concealment technique is applied, which synthesizes a signal replacing the missing packet. The packet loss concealment technique depends on the applied speech encoding scheme.

The eCall simulation framework was extended by a VoIP packetizer, a VoIP end-to-end channel simulator, and a VoIP de-packetizer including a static jitter buffer as described above. The VoIP packetizer converts the encoded speech frames to IP packets, where one compressed speech frame of 20 ms per IP packet is assumed, i.e. either one G.711 A-law encoded 20ms speech frame or two encoded G.729 10 ms speech frames per IP packet. The VoIP channel is modelled by packet losses and varying individual packet delays based on delay and error profiles [13].

The different delay and error profiles [20] used for static IP jitter simulation are the same as those used for the dynamic jitter buffer simulations (see Table 5). These profiles combine a large range of delay jitter characteristics with an additional packet loss probability. All six delay and error profiles were used for simulation with the G.729 A/B codec. For G.711 and G.729 B, only the most challenging profiles 4 and 5 were tested. All delay and error profiles in Table 5 represent VoIP over the air channel conditions, typically exhibiting larger delay variations and higher packet loss rates

than pure network VoIP conditions. Note that in all jitter buffer simulations, the starting point in the delay error profiles was selected randomly for each single MSD transmission.

5.8.2 Jitter buffer with ITU-T G.711 A-law speech frames

For VoIP transmission, each A-law compressed 20ms speech frame of 160 byte is encapsulated in an IP-packet. If an IP packet is dropped, the respective speech frame is replaced by the preceding speech frame scaled down by a factor of 0.8.

The simulation results reproduced in Table 24 show the performance of the eCall modems with packets of G.711 [25] encoded speech transmitted over the IP network, based on different delay and error conditions, where we assume jitter buffers of different delays in the range of 40 ms to 100 ms, corresponding to jitter buffer sizes of 2 to 5 speech frames.

Table 24: Figure of merit (in seconds) with G.711 transcoding and delay jitter

Profile	Jitter buffer size							
	40 ms		60 ms		80 ms		100 ms	
	FoM	95 th prc.	FoM	95 th prc.	FoM	95 th prc.	FoM	95 th prc.
4	4.16	20.26	3.18	8.94	2.44	4.84	2.22	4.22
5	4.82	8.20	4.28	7.12	2.86	4.96	2.52	4.24

5.8.3 Jitter buffer with ITU-T G.729 speech frames

In G.729 coding [13], packet loss concealment based on G.729 encoded speech frames is considered. An error concealment procedure is incorporated in the G.729 decoder. A bad/lost frame is indicated to the G.729 decoder by setting all bits of that frame to zero (apart from the sync word and the serial size word).

Table 25 shows the resulting figures of merit obtained in different channel scenarios and with different jitter buffer delays.

Table 25: Average MSD transmission times (in seconds) over all codecs and C/I conditions used in the selection test with G.729 transcoding and delay jitter

Transcoding	Profile	Jitter buffer size							
		40 ms		60 ms		80 ms		100 ms	
		FoM	95 th prc.	FoM	95 th prc.	FoM	95 th prc.	FoM	95 th prc.
G.729 Annex B based on Annex A	1	3.23	6.40	3.23	6.40	3.23	6.40	3.23	6.40
	2	3.89	7.48	3.31	6.40	3.26	6.40	3.24	6.40
	3	4.25	7.12	3.45	6.40	3.25	6.40	3.24	6.40
	4	10.14	47.18	6.81	23.76	4.01	8.54	3.66	7.14
	5	13.35	36.00	11.88	28.76	5.02	8.92	4.18	8.22
	6	3.23	6.40	3.23	6.40	3.23	6.40	3.23	6.40
G.729 Annex B	4	9.70	46.24	6.65	23.24	3.93	8.22	3.56	6.76
	5	11.06	27.36	9.87	24.56	4.56	8.56	3.95	7.48

While for the G.711 case, no significant increases of MSD transmission times could be observed, certain jitter buffer configurations in the G.729 case (worst-case profiles 4 and 5 together with short buffer lengths) led to notable transmission time increases (but not to transmission failures).

5.9 Noisy conditions

In this test condition, noise was added to the PCM data that is received and/or transmitted by the PSAP. This reflects noise that could occur on an analogue line in a PSTN. Two different types of noise, AWGN and babble noise, were tested. The noise power was set to yield 10 dB SNR.

At the PSAP receiver, the reference signal power was obtained by averaging over all incoming signal intervals while the PSAP receiver is in NACK state, which is the case when it receives the data part of the MSD message. A separate reference signal power was computed for each codec and channel condition as an average of the 100 test cases of the selection test campaign.

At the PSAP transmitter, the reference signal power was obtained by averaging over an entire feedback message consisting of 20 speech frames. This reference signal power is independent of the (wireless) channel conditions and the speech codec applied.

Table 26 shows the results for various configurations. Gaussian noise and Babble noise exhibit approximately the same performance figures. The figure of merit (averaged transmission time over all 2600 test cases of the selection test campaign) of the eCall modem is not affected by noise at the PSAP transmitter. A slight degradation due to noise before the PSAP receiver is observed, but this is significantly less than 10 percent in terms of the figure of merit. The degradation is due to some messages requiring slightly more redundancy information than before. Also, the probability of erroneous synchronization events increases slightly. The latter fact is reflected by a few more instances where the maximum transmission time deviates from the average transmission time of the MSD, see the results in Table 27. Table 27 gives a more detailed representation of the results that were obtained for a simulation with noise at the transmitter and the receiver.

Table 26: Performance of the eCall modem with AWGN and babble noise (Noise SNR = 10 dB)

Noise location	Transmission time (s) for the full campaign [5]					
	Gaussian noise			Babble noise		
	average (FoM)	95 th percentile	maximum	average (FoM)	95 th percentile	maximum
After PSAP transmitter	2.03	3.54	5.86	2.03	3.54	13.06
Before PSAP receiver	2.19	3.90	21.84	2.17	3.90	13.04
At PSAP transmitter and receiver	2.19	3.90	13.74	2.16	3.90	13.74

Table 27: Individual test cases with noise at the PSAP transmitter and receiver (Noise SNR = 10 dB)

Codec and channel condition	Transmission time (s)					
	Gaussian noise			Babble noise		
	average (FoM)	95 th percentile	maximum	average (FoM)	95 th percentile	maximum
Full Rate, 7 dB	2.37	3.70	13.74	2.28	3.70	4.92
Full Rate, 10 dB	1.70	2.06	2.08	1.71	2.06	2.96
Full Rate, 13 dB	1.54	1.74	2.08	1.68	1.74	12.36
Full Rate, 16 dB	1.50	1.74	1.74	1.50	1.74	1.74
Full Rate, clean	1.43	1.74	1.74	1.46	1.74	1.74
Full Rate, RSSI=-100dBm	1.63	1.74	2.06	1.63	1.74	2.06
AMR 12.20, 7 dB	2.16	2.44	12.66	1.95	2.08	3.68
AMR 12.20, 10 dB	1.57	1.74	2.08	1.57	1.74	1.76
AMR 12.20, 13 dB	1.47	1.38	12.38	1.36	1.38	1.74
AMR 12.20, clean	1.35	1.36	1.38	1.35	1.36	1.38
AMR 10.20, 7 dB	1.97	2.08	12.64	1.88	2.08	3.34
AMR 10.20, 10 dB	1.46	1.74	1.76	1.57	1.74	12.36
AMR 10.20, 13 dB	1.38	1.74	1.74	1.39	1.74	1.74
AMR 7.95, 7 dB	1.76	2.08	2.08	1.76	2.08	2.08
AMR 7.95, 10 dB	1.79	1.74	11.96	1.68	1.74	1.76
AMR 7.40, 7 dB	1.83	1.74	12.36	1.74	1.74	2.08
AMR 7.40, 10 dB	1.71	1.74	1.76	1.70	1.74	1.76
AMR 6.70, 7 dB	2.31	2.44	13.04	2.10	2.44	3.68
AMR 5.90, 4 dB	2.47	2.82	3.18	2.49	2.84	3.16
AMR 5.90, 7 dB	2.26	2.44	11.98	2.20	2.44	2.44
AMR 5.15, 4 dB	3.33	3.90	3.90	3.45	3.90	13.04
AMR 5.15, 7 dB	2.87	3.50	13.06	2.81	3.50	3.90
AMR 4.75, 1 dB	4.38	5.50	13.32	4.46	4.98	13.74
AMR 4.75, 4 dB	3.69	4.24	4.60	3.68	4.24	4.60
AMR 4.75, 7 dB	3.58	3.90	13.04	3.41	3.90	4.24
AMR 4.75, RSSI=-100dBm	3.50	3.90	13.06	3.41	3.90	4.24

Summarizing the above results, it can be stated that the MSD transmission is hardly affected by additive noise of moderate power.

5.10 Erroneous tone detection

As part of the eCall selection test, it was verified that the eCall IVS modem is not erroneously triggered by PSTN call tones. For this test, a dummy PSAP modem was developed which sends pre-recorded tones to the IVS. The test was conducted over an error-free AMR 12.2 kbit/s channel with DTX deactivated.

The pre-recorded tones were taken from a PCM file 'EU_DTMF_tones.rawpcm' which is available in an attachment to TS 26.269 [8]. The file is Composed of international call tones of various European Union countries, and of DTMF tones.

In the test, no false triggers occurred.

5.11 Gaps in transmission due to handovers

This test scenario reflects the situation in which a mobile phone loses temporarily the connection due to a frequency handover. This behaviour has been modelled in the test setup by means of setting to zero certain periods of PCM samples in both uplink and downlink (transmission gap), according to the following cases:

- 1) **Successful handover:** Single transmission gap of 0.1 to 1 seconds, where both the duration of the gap and the location of the gap are randomly distributed. The location of the gap is distributed between the start of the transmission and the shortest possible transmission time for the respective codec and channel combination.
- 2) **Handover failure:** Single transmission gap of 1 to 3 seconds, where both the duration of the gap and the location of the gap are randomly distributed as above.
- 3) **Concatenation of two successful handovers:** Two "successful handovers" as above, separated by a normal transmission period of 1 second.
- 4) **Concatenation of two handover failures:** Two "handover failures" as above, separated by a normal transmission period of 1 second.

These cases have been tested against the 26 conditions used for the selection test Results are given in Tables 28 to 35.

**Table 28: Average MSD transmission times (in s) for test case "Successful handover"
(Figure of Merit = 3.86 s)**

Channel condition	GSM FR	AMR 12.2	AMR 10.2	AMR 7.95	AMR 7.4	AMR 6.7	AMR 5.9	AMR 5.15	AMR 4.75
C/I = 1 dB									6.17
C/I = 4 dB							5.36	6.23	5.19
C/I = 7 dB	3.62	3.13	2.93	3.09	3.19	3.62	4.87	5.58	4.96
C/I = 10 dB	2.95	4.08	3.61	3.31	3.42				
C/I = 13 dB	2.60	3.51	2.91						
C/I = 16 dB	2.57								
error free	2.69	3.26							
RSSI = -100 dBm	2.54								4.93

Table 29: 95th percentiles of MSD transmission times (in s) for test case "Successful handover"

Channel condition	GSM FR	AMR 12.2	AMR 10.2	AMR 7.95	AMR 7.4	AMR 6.7	AMR 5.9	AMR 5.15	AMR 4.75
C/I = 1 dB									7.87
C/I = 4 dB						5.36	6.94	13.06	6.72
C/I = 7 dB	5.24	4.18	4.18	4.56	3.62	4.87	6.57	13.04	6.34
C/I = 10 dB	4.54	5.48	4.90	4.56					
C/I = 13 dB	4.16	4.56	4.18						
C/I = 16 dB	4.16								
error free	4.18	4.18							
RSSI = -100 dBm	3.96								6.34

**Table 30: Average MSD transmission times (in s) for test case "Handover failure"
(Figure of Merit = 5.07 s)**

Channel condition	GSM FR	AMR 12.2	AMR 10.2	AMR 7.95	AMR 7.4	AMR 6.7	AMR 5.9	AMR 5.15	AMR 4.75
C/I = 1 dB									7.28
C/I = 4 dB							7.16	7.56	6.46
C/I = 7 dB	4.59	4.31	4.05	4.16	4.30	4.75	6.78	6.78	6.17
C/I = 10 dB	4.02	5.31	4.54	4.43	4.47				
C/I = 13 dB	3.67	4.64	4.03						
C/I = 16 dB	3.66								
error free	3.76	4.33							
RSSI = -100 dBm	3.63								6.12

Table 31: 95th percentiles of MSD transmission times (in s) for test case "Handover failure"

Channel condition	GSM FR	AMR 12.2	AMR 10.2	AMR 7.95	AMR 7.4	AMR 6.7	AMR 5.9	AMR 5.15	AMR 4.75
C/I = 1 dB									8.60
C/I = 4 dB						7.16	13.04	12.46	7.91
C/I = 7 dB	6.27	5.38	5.38	5.76	4.75	6.78	12.36	13.04	7.91
C/I = 10 dB	5.74	6.49	6.08	5.76					
C/I = 13 dB	5.36	5.76	5.38						
C/I = 16 dB	5.36								
error free	5.56	5.38							
RSSI = -100 dBm	5.16								7.54

**Table 32: Average MSD transmission times (in s) for test case
"Concatenation of two successful handovers" (Figure of Merit = 5.23 s)**

Channel condition	GSM FR	AMR 12.2	AMR 10.2	AMR 7.95	AMR 7.4	AMR 6.7	AMR 5.9	AMR 5.15	AMR 4.75
C/I = 1 dB									7.55
C/I = 4 dB							9.17	11.59	6.73
C/I = 7 dB	4.12	4.02	3.62	3.85	4.15	4.49	8.61	10.47	6.46
C/I = 10 dB	3.38	5.23	4.46	4.06	4.32				
C/I = 13 dB	2.76	4.63	3.56						
C/I = 16 dB	2.73								
error free	2.69	4.14							
RSSI = -100 dBm	2.93								6.30

Table 33: 95th percentiles of MSD transmission times (in s) for test case "Successful handover"

Channel condition	GSM FR	AMR 12.2	AMR 10.2	AMR 7.95	AMR 7.4	AMR 6.7	AMR 5.9	AMR 5.15	AMR 4.75
C/I = 1 dB									9.80
C/I = 4 dB						9.17	13.64	15.72	9.10
C/I = 7 dB	7.64	6.58	6.56	6.94	4.49	8.61	12.36	15.05	8.74
C/I = 10 dB	6.94	7.34	7.28	6.94					
C/I = 13 dB	6.56	6.94	6.94						
C/I = 16 dB	6.56								
error free	6.56	6.58							
RSSI = -100 dBm	5.70								8.72

Table 34: Average MSD transmission times (in s) for test case "Concatenation of two handover failures" (Figure of Merit = 6.62 s)

Channel condition	GSM FR	AMR 12.2	AMR 10.2	AMR 7.95	AMR 7.4	AMR 6.7	AMR 5.9	AMR 5.15	AMR 4.75
C/I = 1 dB									9.26
C/I = 4 dB							11.42	12.74	8.45
C/I = 7 dB	6.16	5.33	4.64	4.83	5.11	6.40	10.33	11.58	8.14
C/I = 10 dB	4.66	7.33	5.54	5.17	5.22				
C/I = 13 dB	3.91	6.02	4.58						
C/I = 16 dB	3.88								
error free	4.08	5.34							
RSSI = -100 dBm	3.83								8.18

Table 35: 95th percentiles of MSD transmission times (in s) for test case "Successful handover"

Channel condition	GSM FR	AMR 12.2	AMR 10.2	AMR 7.95	AMR 7.4	AMR 6.7	AMR 5.9	AMR 5.15	AMR 4.75
C/I = 1 dB									11.04
C/I = 4 dB						11.42	16.24	16.92	9.92
C/I = 7 dB	9.26	8.16	7.38	7.76	6.40	10.33	15.56	16.64	9.92
C/I = 10 dB	8.54	8.90	8.33	7.92					
C/I = 13 dB	8.16	8.54	7.74						
C/I = 16 dB	8.16								
error free	8.18	8.16							
RSSI = -100 dBm	8.18								10.14

Naturally, gaps in the transmission impact the transmission performance in any communication system. It was shown that the eCall modem is able to finalize the MSD transmission successfully within a reasonable time after the transmission has been re-established.

5.12 Change of speech codec

Two scenarios were defined for testing the eCall inband modem with the change of speech codec: Change of AMR codec modes, and Change of speech codec in handover.

5.12.1 Change of AMR codec modes

This scenario considers basic sequential shifts of AMR modes (12.2→7.4→5.9→4.75→4.75→7.4→12.2→...). The same test setup as for the test item 'varying channel conditions' was used. The only change was in the AMR codec itself which was modified to change its mode periodically (so that the coder is not reset between mode changes). Two time periods were tested for the mode change: 400 ms and 800 ms.

The results can be found in Table 36. Note that for the varying C/I condition, the C/I pattern is given by 10dB→10dB→7dB→7dB.... All MSD transmissions were successful.

Table 36: MSD transmission times (in s) for change of AMR codec modes

Channel condition	MSD transmission time	Mode change period	
		400ms	800ms
Error free	Average	1.82	2.14
	95th perc.	2.08	2.44
	Maximum	2.08	2.44
C/I=7dB	Average	2.08	2.23
	95th perc.	2.44	2.44
	Maximum	3.34	2.46
Varying C/I	Average	1.94	2.21
	95th perc.	2.08	2.44
	Maximum	2.10	2.46

5.12.2 Change of speech codec in handover

This scenario considers several handover cases, as listed in Table 37.

The eCall test setup was run on a single computer. Two coder/decoder instances (Codec 0 and Codec 1) were initialized. Until the change of codec, only codec 0 was used just like other eCall experiments. The change of codec was then performed from codec 0 to codec 1, and the time of change was set to 1s after the start of transmission (PSAP start). The codec switching itself was implemented by switching the associated coder/decoder outputs. Note that one zero frame (20 ms of silence) was fed to Codec 1 when Codec 0 was processing its last frame before codec change.

The results obtained are shown in Table 37, with 95th percentiles and the average MSD transmission times. All MSD transmissions were successful. The results for switching from AMR to AMR (with mode change) are consistent with Table 36. However, the results in Table 37 show that the simulated switching between different codecs (with different time alignment) results in significantly higher transmission times than (from 11 s to 22 s). This may be interpreted by a loss of synchronization of the eCall inband modem in case of codec change when the two codec synthesized signals have different time alignments.

Table 37: MSD transmission times (in s) for change of codecs

Codec 0	Codec 1	Channel condition	MSD transmission time		
			Average	95th perc.	Maximum
FR (GSM) -> AMR12.2 (GSM)					
FR	AMR 12.2	GSM C/I=7dB	12.92	13.34	31.44
FR	AMR 12.2	GSM C/I=10dB	11.71	11.76	30.38
FR	AMR 12.2	GSM C/I=13dB	11.37	11.38	11.76
FR	AMR 12.2	Error free	11.36	11.38	11.40
AMR 12.2 (GSM) -> FR (GSM)					
AMR 12.2	FR	GSM C/I=10dB	11.86	12.1	30.34
AMR 12.2	FR	GSM C/I=13dB	11.45	11.74	12.12
AMR 12.2	FR	GSM C/I=7dB	12.60	14.08	31.04
AMR 12.2	FR	Error free	11.37	11.36	11.74
EFR (GSM) -> AMR 12.2 (GSM)					
EFR	AMR 12.2	Error free	11.36	11.38	11.40
EFR	AMR 12.2	GSM C/I=10dB	11.94	11.76	31.06
EFR	AMR 12.2	GSM C/I=13 dB	11.36	11.38	11.74
EFR	AMR 12.2	GSM C/I=7dB	12.01	12.48	13.70
AMR 12.2 (GSM) -> EFR (GSM)					
AMR 12.2	EFR	Error free	12.67	30.36	30.38
AMR 12.2	EFR	GSM C/I=10dB	12.87	30.36	30.38
AMR 12.2	EFR	GSM C/I=13dB	12.11	11.36	30.38
AMR 12.2	EFR	GSM C/I=7dB	13.49	30.36	31.46
AMR (GSM) -> AMR (GSM) with mode change					
AMR 12.2	AMR 7.4	GSM C/I=10dB	1.66	1.74	1.74
AMR 7.4	AMR 12.2	GSM C/I=10 dB	1.68	1.74	1.76
AMR 7.4	AMR 5.9	GSM C/I=7dB	1.87	2.08	2.10
AMR 5.9	AMR 7.4	GSM C/I=7dB	1.94	2.08	2.10
AMR 5.9	AMR 4.75	GSM C/I=4dB	2.87	3.5	3.52
AMR 4.75	AMR 5.9	GSM C/I=4dB	2.61	2.82	3.16
AMR 12.2 (GSM) -> AMR 12.2 (GSM)					
AMR 12.2	AMR 12.2	GSM C/I=7dB	2.31	2.44	31.04
AMR 12.2	AMR 12.2	GSM C/I=10dB	1.61	1.74	2.08
AMR 12.2	AMR 12.2	GSM C/I=13dB	1.37	1.36	1.76
AMR 12.2	AMR 12.2	Error free	1.35	1.36	1.38
AMR 12.2 (GSM) -> HR (GSM)					
AMR 12.2	HR	Error free	16.28	16.76	18.56
AMR 12.2	HR	GSM C/I=10dB	17.90	19.32	31.72
AMR 12.2	HR	GSM C/I=7dB	22.14	28.52	37
HR (GSM) -> AMR 12.2 (GSM)					
HR	AMR 12.2	Error free	11.36	11.38	11.38
HR	AMR 12.2	GSM C/I=10dB	12.48	14.16	31.34
HR	AMR 12.2	GSM C/I=7dB	18.19	49.84	51.84

5.13 Sample slip / small delay variations at handover

In this scenario, the eCall modem confronts a loss of synchronization in the stream of data due to a handover. The conditions tested for this scenario are:

Simple Shift, from Left to Right

Double Shift, from Left to Right

Simple Shift, from Right to Left

Double Shift, from Right to Left

Where a simple shift means a 1 sample shift and a double shift means a 2 sample shift. Apart from these 4 subgroups, the tests were carried out for handover periods (intervals between successive handovers) of 2, 5 and 10 seconds. Each handover, during which the sample slip exclusively occurs, has a duration of 1 second.

The average MSD transmission times (FoM) for the selection test campaign with the above sample slip scenarios are summarized in Table 38. More detailed data, including individual results per codec / channel condition as well as 95th percentiles, is collected in Annex C.3.

Table 38: Average MSD transmission times (in s) for sample slip scenarios

Scenario	Handover period		
	2 s	5 s	10 s
Simple Shift, from Left to Right	4.97	4.22	4.23
Double Shift, from Left to Right	7.23	4.89	4.76
Simple Shift, from Right to Left	5.41	4.26	4.17
Double Shift, from Right to Left	5.19	4.13	4.08

5.14 Combinations of test conditions

5.14.1 GSM HR and HR AMR with transcoding (G.729 / G.726) under different channel conditions

In this test case, the eCall modem performance is tested under the use of the AMR-HR and GSM-HR speech codecs in conjunction with G726 and G729a transcoding for a set of different channel conditions.

The numerical results are presented in the Tables 39 to 42 below:

Table 39: Average MSD transmission times (in s) for half rate transmission and G.726 transcoding

Channel condition	Average MSD transmission time (in seconds)						
	GSM HR	HR AMR 7.95	HR AMR 7.4	HR AMR 6.7	HR AMR 5.9	HR AMR 5.15	HR AMR 4.75
C/I = 4dB	21.986	11.6108	6.5652	9.0782	8.5632	9.1428	8.6566
C/I = 7dB	10.908	4.4642	5.1306	4.0282	5.0374	5.3208	5.5692
C/I = 10dB	7.584	3.1616	2.3694	2.9216	3.3288	3.8966	4.3154

Table 40: 95th percentile MSD transmission times (in s) for half rate transmission and G.726 transcoding

Channel condition	Average MSD transmission time (in seconds)						
	GSM HR	HR AMR 7.95	HR AMR 7.4	HR AMR 6.7	HR AMR 5.9	HR AMR 5.15	HR AMR 4.75
C/I = 4dB	37.62	37.28	24.02	34.6	20.72	22.36	21.36
C/I = 7dB	16.54	15.46	16.32	9.54	11.8	14	8.82
C/I = 10dB	8.94	6.88	4.28	4.64	5.78	5.79	5.84

Table 41: Average MSD transmission times (in s) for half rate transmission and G.729a transcoding

Channel condition	Average MSD transmission time (in seconds)						
	GSM HR	HR AMR 7.95	HR AMR 7.4	HR AMR 6.7	HR AMR 5.9	HR AMR 5.15	HR AMR 4.75
C/I = 4dB	173.458	10.94	7.972	12.944	14.728	20.576	23.272
C/I = 7dB	30.06	5.38	4.52	6.382	7.056	8.576	9.948
C/I = 10dB	23.082	4.1	3.24	4.982	4.55	6.314	6.896

Table 42: 95th percentile MSD transmission times (in s) for half rate transmission and G.729a transcoding

Channel condition	Average MSD transmission time (in seconds)						
	GSM HR	HR AMR 7.95	HR AMR 7.4	HR AMR 6.7	HR AMR 5.9	HR AMR 5.15	HR AMR 4.75
C/I = 4dB	200	23.22	18.14	40.52	38.8	40.9	42.28
C/I = 7dB	47.12	8.96	7.74	13.32	10.96	15.32	18.52
C/I = 10dB	34.78	5.92	4.8	7.74	7	8.26	8.36

5.14.2 CSoHS with transcoding (G.729a / G.711) and echo cancellation

This scenario reflects the situation in which the MSD transmission performed by the eCall modem suffers from the effects of an Echo Canceller presence (see clause 5.2) and the variable delays of a CSoHS environment with static jitter buffer of length 40 ms (see clause 5.8). The eCall modem performance has been tested with regular transcoding (G711 case) or G729a (see clause 5.3) in conjunction with a couple of delay profiles, as defined in [20]. The numerical results (average MSD transmission times for the codec and C/I conditions used in the selection test) can be found in Table 43 below:

Table 43: Figures of Merit (in s) over all codecs and C/I conditions used in the selection test with transcoding, CSoHS jitter buffer (length 40 ms), and echo canceller

Delay/Error Profile [20]	Transcoding	
	G.711	G.729a
3	2.3666	3.9841
4	2.3279	3.8767
5	2.3254	3.8551
6	2.3260	3.8440

More detailed results per codec and C/I condition, as well as 95th percentile transmission times, can be found in clause C.4.

Annex A: eCall test setup

Figure A.1 shows the physical setup during the host lab selection test session. The design of the test setup software [7] is, however, such, that all EXE modules could also be hosted by one PC.

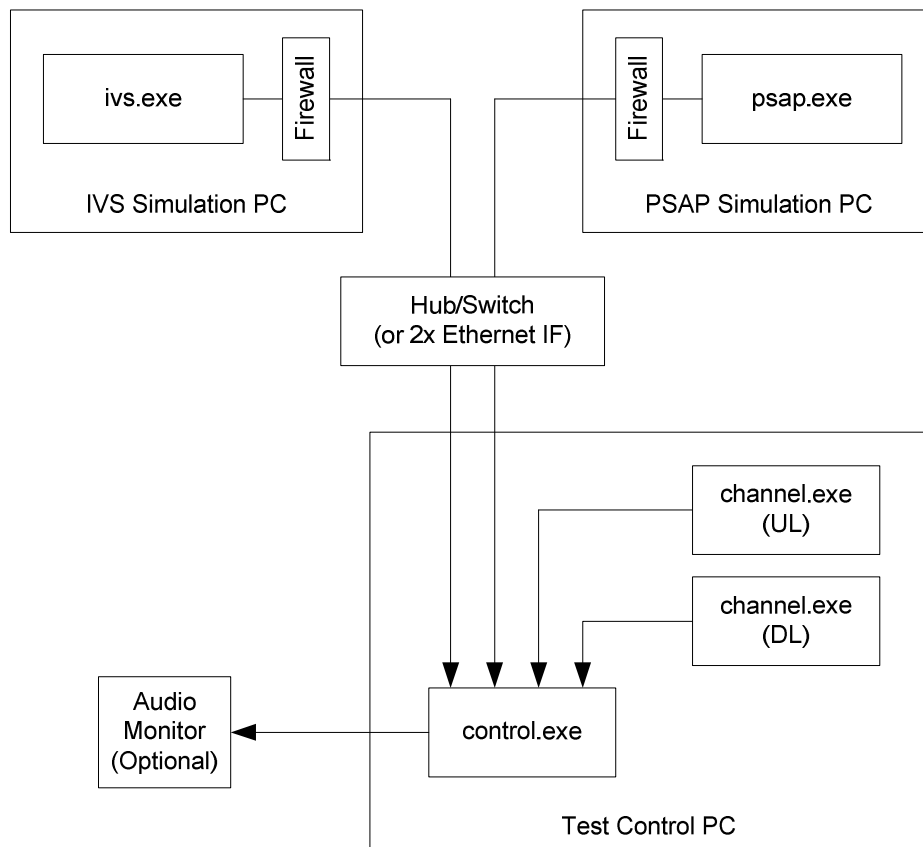

Figure A.1: Physical test setup for eCall (arrows indicate direction of connection establishment)

The candidate IVS.EXE and the candidate PSAP.EXE are physically connected through the test control PC in order to allow monitoring and logging of the PCM data streams between them and to allow real time processing. Per default no logging will take place and the processing will run as fast as possible, typically much faster than real time.

For this discussion, the test executables are CONTROL.EXE and CHANNEL.EXE (UPLINK and DOWNLINK have similar functionality and are simply different instances of the same executable), and the candidate modem executables are PSAP.EXE and IVS.EXE. Refer to Figure A.2 for the logical test setup.

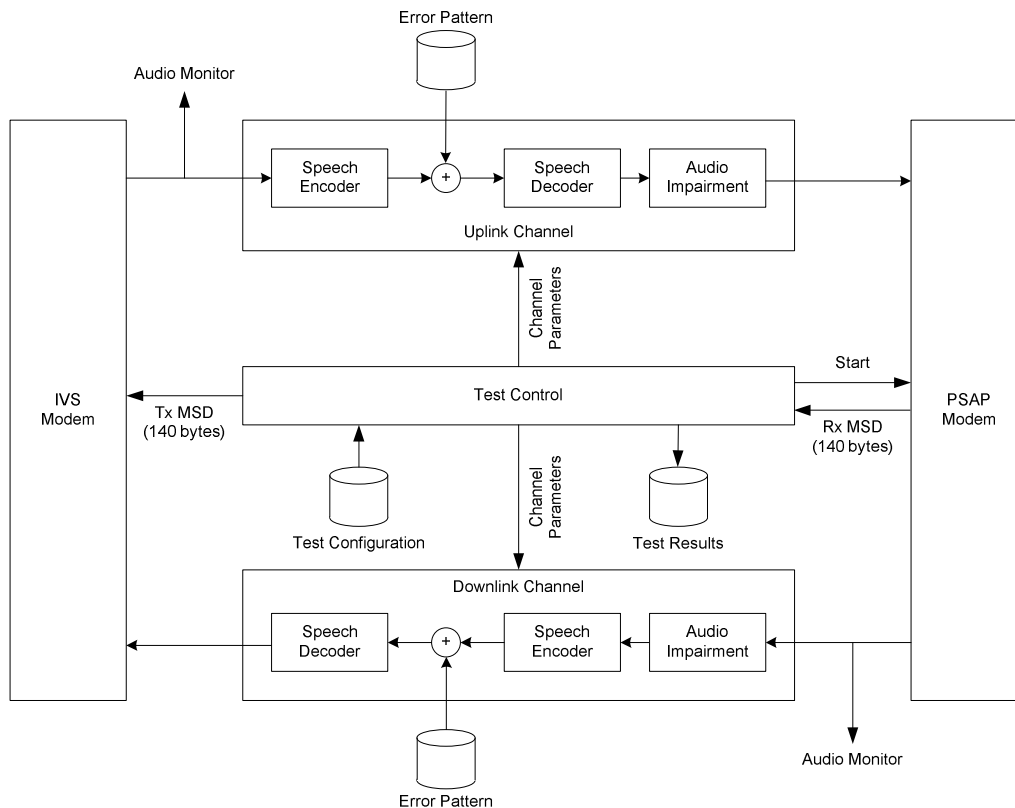

Figure A.2: Logical Test Setup for eCall Candidate Selection

A.1 Specification of the Test Control

The test shall be repeatable in a bit exact manner. Therefore the test control parameters are stored in one **Test Configuration** table, which is used identically for each candidate. Each candidate modem will be tested with the same ASCII Test Configuration table so that each tested modem uses the same set of data and same channel conditions.

The Speech Codec (Encoder/Decoder and Codec Mode) is identical for uplink & downlink.

The error patterns are in general different in uplink and downlink, at least the start indices are different. Each error pattern will last 10 minutes (repeat if necessary). The start index is a randomly generated offset for each test run to the beginning of the error pattern between 0-10 minutes, in 20 ms granularity. The offset will be uniformly distributed across the whole error pattern. If during testing, the end of the pattern is reached, the index will wrap around to the beginning of the error pattern.

The test control block fetches each line of data from the Test Configuration table, sets constants, and performs resets of all other blocks. A line of data in the Test Configuration table corresponds to the parameters for one trial. Entries in the Test Configuration table are listed in 13 columns:

Index MSD Codec_Type Codec_Mode VAD UL_delay1 UL_delay2 UL_EP UL_EP_index
DL_delay1 DL_delay2 DL_EP DL_EP_index.

Index is a running number between [1 , 2600] identifying the individual test run.

All audio frames between IVS and PSAP flow through the test control block. There is no direct physical connection from PSAP or IVS to the uplink processing or downlink processing.

A.1.1 Measurement of the MSD transmission time

The test control block will monitor the PCM output frames of the IVS. The first non-zero PCM output frame after re-initialisation will start the timer for delivery of the MSD. The control block then counts the number of IVS output frames and for each adds 20 ms to the timer. The timer stops when the PSAP finishes delivering the completed MSD to the test control block or after 200 seconds (200 * 50 IVS output frames), whichever comes first. The timer value is the desired MSD transmission time and is stored as `Elapsed_time`.

The received MSD is checked bit by bit against the sent MSD from the control table. The result is stored as `Success_failure_flag` ('S' or 'F'). The `Received_MSD` is stored for debugging purposes.

The result of the test trial shall be stored in the next sequential row of the output table. The output table shall take the following form, listed in 16 columns:

```
Index MSD Codec_Type Codec_Mode VAD UL_delay1 UL_delay2 UL_EP UL_EP_index
      DL_delay1 DL_delay2 DL_EP DL_EP_index
Elapsed_time Success_failure_flag Received_MSD.
```

The above process is then repeated for the next trial until the data in the Test Configuration table is exhausted.

A second test is to test for false detection. Each candidate provides its own trigger. The IVS will be tested separately for false detection, 30-minutes of speech and 30-minutes of tone). The host lab reports the number of false detections.

A.2 PCM Interface Specification

All PCM Interfaces between IVS, Uplink-processing, PSAP, Downlink_processing and the Test_Control use 16 bit linear PCM. The value representation is Q15, i.e. the most significant bit is the sign bit, the next 15 bits represent the sample value in the range of [0, 32767 / 32768], normalized to the overload point of the A/D converter: fixed point arithmetic.

In case an output variable of a processing block would be greater than or lower than Q15 can represent, the value of that variable is limited to the maximum respectively minimum of Q15.

A.3 Specification of Uplink processing

* **UL Reset function** defines `UL_delay1` for the 1st block and `UL_delay2` for the 6th block, Codec Type, Codec Mode, error pattern for uplink (`UL_EP`), start index for error pattern (`UL_EP_index`).

The Reset for the uplink processing blocks simulates a new call setup for each test run. All filter variables and delay buffer memories are cleared to 0x0000. The Speech Encoder and Decoder are set into their Home States.

* **UL Processing function:**

Input interface: 16 bit linear PCM, 8 KHz sampling in blocks of 20 ms.

1st block: constant, definable delay of 10-30 ms (uniformly distributed between 80-239 (0-based indexing) samples). Figure A.3 shows the delay in context of the overall 2-way delay.

`UL_Delay1` is randomly chosen by the host lab, but constant for each test trial.

2nd block: speech encoder

3rd block: error insertion device

4th block: speech decoder

5th block: audio impairment: band pass filter, G.711 A-law encoder-decoder [25]

6th block: constant, definable delay of 10-30 ms (uniformly distributed between 80-239 (0-based indexing) samples). Figure A.3 shows the delay in context of the overall 2-way delay.

`UL_Delay2` is randomly chosen by the host lab, but constant for each test trial.

Output interface: 16 bit linear PCM, 8 KHz sampling in blocks of 20 ms.

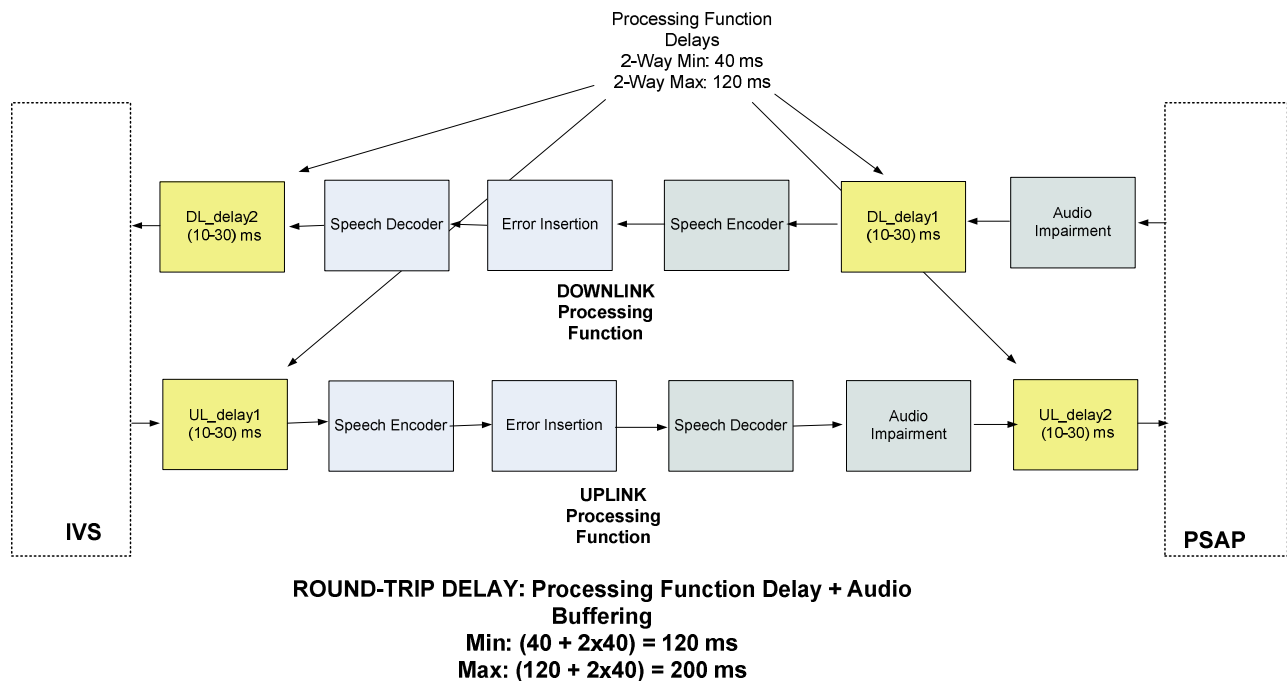

Figure A.3: Uplink and Downlink Processing Function Delay Blocks

A.4 Specification of downlink processing blocks

* **DL Reset function** defines DL_delay1 for the 2nd block, DL_delay2 for the 6th block, Codec Type, Codec Mode, error pattern for downlink (DL_EP), start index for error pattern (DL_EP_index).

The Reset for the downlink processing blocks simulates a new call setup for each test run. All filter variables and delay buffer memories are cleared to 0x0000. The Speech Encoder and Decoder are set into their Home States.

* DL Processing function:

Input interface: 16 bit linear PCM, 8 KHz sampling in blocks of 20 ms.

1st block: audio impairment: band pass filter, G.711 A-law encoder-decoder [25]

2nd block: constant, definable delay of 10-30 ms (uniformly distributed between 80-239 (0-based indexing) samples). Figure A.3 shows the delay in context of the overall 2-way delay.

DL_Delay1 is randomly chosen by the host lab, but constant for each test trial.

3rd block: speech encoder

4th block: error insertion device

5th block: speech decoder

6th block: constant delay of 10-30 ms (uniformly distributed between 80-239 (0-based indexing) samples). Figure A.3 shows the delay in context of the overall 2-way delay.

DL_Delay2 is randomly chosen by the host lab, but constant for each test trial.

Output interface: 16 bit linear PCM, 8 KHz sampling in blocks of 20 ms.

A.5 Specification of IVS

* **IVS Reset function:** The Control block sends the MSD, taken from the test control table, to the IVS at every start of a test run. The IVS then performs its internal re-initialization.

* **IVS Processing function:**

Input interface: 16 bit linear PCM, 8 KHz sampling in blocks of 20 ms.

The IVS gets its input data from the downlink processing (via the test control block).

After reception of the next 20ms block the IVS processes this block and delivers a next 20ms block to the uplink processing (via the test control block).

Output interface: 16 bit linear PCM, 8 KHz sampling in blocks of 20 ms.

After initialization the IVS shall send all-zero data blocks, until the trigger signal from the PSAP is detected. Once triggered by the PSAP, the IVS shall begin sending the MSD. The Test Control detects the first non-zero data block and starts time measurement.

Note: the trigger signal shall be designed to be robust against false trigger. It is to be defined how this is evaluated. Each candidate provides its own trigger. The IVS will be tested separately for false detection, 30-minutes of speech and 30-minutes of tone).

A.6 Specification of PSAP

* **PSAP Reset function:** The Control block sends a start signal to the PSAP at every start of a test run. The PSAP then performs its internal re-initialization.

* **PSAP Processing function:**

Input interface: 16 bit linear PCM, 8 KHz sampling in blocks of 20 ms.

The PSAP gets its input data from the uplink processing (via the test control block).

After reception of the next 20ms block the PSAP processes this block and delivers a next 20ms block to the downlink processing (via the test control block).

Output interface: 16 bit linear PCM, 8 KHz sampling in blocks of 20 ms.

From initialization, the PSAP immediately shall send its trigger signal to the IVS.

The PSAP shall attempt to decode the MSD coming from the IVS. Once the PSAP believes the MSD to be complete, it immediately shall send it to the test control block. The Test Control stops time measurement when it receives the MSD.

Annex B: Required transmission times for IVS initiated eCall signalling and HL-ACK

With the selection test campaign the following results were obtained:

Processing block 1 (this block can be omitted in an alternate modem configuration):

The time from transmitting the first "SEND" message until its successful detection is on average approximately 1 second, the minimum time is approximately 0.8 seconds. In all test cases of the selection test campaign the "SEND" message was successfully detected. The limit of "SEND" transmission time was set to 2 seconds, corresponding to the duration of five "SEND" messages.

Processing block 3:

The transmission of five HL-ACK frames takes approximately 2 seconds. Simulating the selection test campaign, the HL-ACK was always successfully detected.

Identical test cases as above were simulated again with G.729 Annex BA, resulting in 100 % successful detections of both SEND and HL-ACK messages.

In **processing block 2**, there are two time intervals outside of the actual MSD transmission time (determining the Figure of Merit). The first interval, ranging from the first transmission to the detection of START messages, typically lasted 1.16 s in characterization test simulations. The duration of the second interval, consisting of the transmission of LL-ACK messages after the MSD has been received, depends on the number of LL-ACK messages. According to [9], at least four LL-ACK messages shall be transmitted, which results in a duration of approximately 1.6 s.

Annex C: Extended simulation results

C.1 Dynamic jitter buffer

Table C.1a: Average MSD transmission times for dynamic jitter buffer with delay and error profile 1 (original modem version [27])

Condition	GSM FR	AMR 12.2	AMR 10.2	AMR 7.95	AMR 7.4	AMR 6.7	AMR 5.9	AMR 5.15	AMR 4.75
C/I = 1dB									6.82
C/I = 4dB							6.63	7.41	6.46
C/I = 7dB	5.96	2.42	3.55	3.27	3.74	4.92	6.49	7.17	6.47
C/I = 10dB	2.55	4.67	4.40	3.63	3.85				
C/I = 13dB	3.07	2.83	2.60						
C/I = 16dB	2.98								
Error-free	4.67	2.81							
RSSI = -100dBm	3.12								5.97

Table C.1b: Average MSD transmission times for dynamic jitter buffer with delay and error profile 1 (updated modem version [29])

Condition	GSM FR	AMR 12.2	AMR 10.2	AMR 7.95	AMR 7.4	AMR 6.7	AMR 5.9	AMR 5.15	AMR 4.75
C/I = 1dB									6.21
C/I = 4dB							3.49	4.61	4.93
C/I = 7dB	3.35	2.85	2.65	2.66	2.55	3.01	3.21	4.19	4.66
C/I = 10dB	2.51	2.39	2.23	2.49	2.53				
C/I = 13dB	2.47	2.23	2.33						
C/I = 16dB	2.53								
error free	3.27	2.86							
RSSI = -100dBm	2.47								4.65

Table C.2a: 95th percentiles of MSD transmission times for profile 1 (original modem version [27])

Condition	GSM FR	AMR 12.2	AMR 10.2	AMR 7.95	AMR 7.4	AMR 6.7	AMR 5.9	AMR 5.15	AMR 4.75
C/I = 1dB									15.87
C/I = 4dB							15.71	31.33	15.56
C/I = 7dB	24.32	7.50	11.45	11.90	15.21	23.39	31.54	31.55	15.53
C/I = 10dB	3.58	15.60	14.57	14.06	13.65				
C/I = 13dB	12.64	12.30	12.86						
C/I = 16dB	12.45								
error free	11.84	12.45							
RSSI = -100dBm	11.46								16.93

**Table C.2b: 95th percentiles of MSD transmission times for profile 1
(updated modem version [29])**

Condition	GSM FR	AMR 12.2	AMR 10.2	AMR 7.95	AMR 7.4	AMR 6.7	AMR 5.9	AMR 5.15	AMR 4.75
C/I = 1dB									8.04
C/I = 4dB							5.12	6.88	6.88
C/I = 7dB	5.56	4.68	4.24	4.70	4.68	4.70	5.12	5.56	6.02
C/I = 10dB	4.06	4.22	3.38	3.80	4.24				
C/I = 13dB	4.22	4.22	3.80						
C/I = 16dB	4.24								
error free	3.38	3.38							
RSSI = -100dBm	3.80								6.44

**Table C.3a: Average MSD transmission times for dynamic jitter buffer with delay and error profile 2
(original modem version [27])**

Condition	GSM FR	AMR 12.2	AMR 10.2	AMR 7.95	AMR 7.4	AMR 6.7	AMR 5.9	AMR 5.15	AMR 4.75
C/I = 1dB									14.00
C/I = 4dB							8.33	9.49	12.80
C/I = 7dB	5.49	6.55	5.62	6.71	7.07	7.12	6.00	10.61	11.40
C/I = 10dB	5.77	7.74	5.26	5.42	6.10				
C/I = 13dB	5.87	6.56	8.51						
C/I = 16dB	4.74								
error free	5.16	8.83							
RSSI = -100dBm	5.72								9.97

**Table C.3b: Average MSD transmission times for dynamic jitter buffer with delay and error profile 2
(updated modem version [29])**

Condition	GSM FR	AMR 12.2	AMR 10.2	AMR 7.95	AMR 7.4	AMR 6.7	AMR 5.9	AMR 5.15	AMR 4.75
C/I = 1dB									5.65
C/I = 4dB							3.37	4.50	4.83
C/I = 7dB	3.27	2.82	2.68	2.64	2.49	2.89	3.01	4.11	4.61
C/I = 10dB	2.49	2.25	2.26	2.35	2.46				
C/I = 13dB	2.38	2.17	2.16						
C/I = 16dB	2.40								
error free	4.59	4.25							
RSSI = -100dBm	2.36								4.35

**Table C.4a: 95th percentiles of MSD transmission times for profile 2
(original modem version [27])**

Condition	GSM FR	AMR 12.2	AMR 10.2	AMR 7.95	AMR 7.4	AMR 6.7	AMR 5.9	AMR 5.15	AMR 4.75
C/I = 1dB									50.40
C/I = 4dB							34.40	40.42	51.08
C/I = 7dB	27.38	33.14	31.74	34.58	34.76	32.54	32.18	41.30	42.62
C/I = 10dB	32.70	32.96	31.86	31.88	32.18				
C/I = 13dB	32.18	36.52	49.40						
C/I = 16dB	27.40								
error free	32.10	51.64							
RSSI = -100dBm	31.34								45.86

**Table C.4b: 95th percentiles of MSD transmission times for profile 2
(updated modem version [29])**

Condition	GSM FR	AMR 12.2	AMR 10.2	AMR 7.95	AMR 7.4	AMR 6.7	AMR 5.9	AMR 5.15	AMR 4.75
C/I = 1dB									7.78
C/I = 4dB							4.72	6.02	6.46
C/I = 7dB	5.34	4.52	4.72	4.72	3.82	4.72	5.12	6.04	6.90
C/I = 10dB	4.50	3.38	3.82	3.80	4.24				
C/I = 13dB	3.82	3.82	3.40						
C/I = 16dB	4.24								
error free	4.70	4.24							
RSSI = -100dBm	3.82								5.58

**Table C.5a: Average MSD transmission times for dynamic jitter buffer with delay and error profile 3
(original modem version [27])**

Condition	GSM FR	AMR 12.2	AMR 10.2	AMR 7.95	AMR 7.4	AMR 6.7	AMR 5.9	AMR 5.15	AMR 4.75
C/I = 1dB									14.72
C/I = 4dB							13.10	15.39	13.59
C/I = 7dB	10.21	6.57	7.10	8.14	8.80	12.21	10.44	13.66	12.22
C/I = 10dB	6.51	9.27	7.04	7.20	9.31				
C/I = 13dB	5.99	7.27	8.70						
C/I = 16dB	6.26								
error free	5.72	6.74							
RSSI = -100dBm	6.27								15.79

**Table C.5b: Average MSD transmission times for dynamic jitter buffer with delay and error profile 3
(updated modem version [29])**

Condition	GSM FR	AMR 12.2	AMR 10.2	AMR 7.95	AMR 7.4	AMR 6.7	AMR 5.9	AMR 5.15	AMR 4.75
C/I = 1dB									5.99
C/I = 4dB							3.73	4.99	5.15
C/I = 7dB	3.69	3.12	3.02	3.03	2.87	3.25	3.50	4.39	5.14
C/I = 10dB	2.83	2.72	2.46	2.76	2.79				
C/I = 13dB	2.58	2.51	2.68						
C/I = 16dB	2.73								
error free	2.09	2.03							
RSSI = -100dBm	2.73								4.75

**Table C.6a: 95th percentiles of MSD transmission times for profile 3
(original modem version [27])**

Condition	GSM FR	AMR 12.2	AMR 10.2	AMR 7.95	AMR 7.4	AMR 6.7	AMR 5.9	AMR 5.15	AMR 4.75
C/I = 1dB									43.90
C/I = 4dB							36.02	53.50	51.20
C/I = 7dB	36.78	33.12	31.60	56.96	33.20	37.46	40.20	50.86	34.56
C/I = 10dB	24.98	35.20	32.46	31.50	42.90				
C/I = 13dB	31.66	31.78	32.70						
C/I = 16dB	31.42								
error free	32.58	32.46							
RSSI = -100dBm	31.26								50.46

**Table C.6b: 95th percentiles of MSD transmission times for profile 3
(updated modem version [29])**

Condition	GSM FR	AMR 12.2	AMR 10.2	AMR 7.95	AMR 7.4	AMR 6.7	AMR 5.9	AMR 5.15	AMR 4.75
C/I = 1dB									8.20
C/I = 4dB							6.02	7.32	6.88
C/I = 7dB	5.70	5.12	4.70	4.72	4.68	4.70	5.12	6.44	7.34
C/I = 10dB	4.68	4.24	4.24	4.68	4.68				
C/I = 13dB	4.22	4.24	4.24						
C/I = 16dB	4.22								
error free	2.46	2.04							
RSSI = -100dBm	4.24								6.86

**Table C.7a: Average MSD transmission times for dynamic jitter buffer with delay and error profile 4
(original modem version [27])**

Condition	GSM FR	AMR 12.2	AMR 10.2	AMR 7.95	AMR 7.4	AMR 6.7	AMR 5.9	AMR 5.15	AMR 4.75
C/I = 1dB									18.49
C/I = 4dB							13.85	14.02	16.86
C/I = 7dB	15.36	13.24	10.74	14.03	10.64	15.61	16.86	18.55	15.97
C/I = 10dB	11.84	12.92	1	10.83	12.64				
C/I = 13dB	10.03	9.17	11.60						
C/I = 16dB	11.59								
error free	14.28	9.14							
RSSI = -100dBm	8.22								16.18

**Table C.7b: Average MSD transmission times for dynamic jitter buffer with delay and error profile 4
(updated modem version [29])**

Condition	GSM FR	AMR 12.2	AMR 10.2	AMR 7.95	AMR 7.4	AMR 6.7	AMR 5.9	AMR 5.15	AMR 4.75
C/I = 1dB									7.88
C/I = 4dB							4.80	6.23	6.50
C/I = 7dB	4.74	3.85	4.18	3.28	3.92	4.67	4.46	5.49	6.48
C/I = 10dB	4.21	3.58	3.39	3.60	3.37				
C/I = 13dB	3.65	2.74	3.27						
C/I = 16dB	2.89								
error free	2.45	2.38							
RSSI = -100dBm	3.57								6.20

**Table C.8a: 95th percentiles of MSD transmission times for profile 4
(original modem version [27])**

Condition	GSM FR	AMR 12.2	AMR 10.2	AMR 7.95	AMR 7.4	AMR 6.7	AMR 5.9	AMR 5.15	AMR 4.75
C/I = 1dB									42.42
C/I = 4dB							51.36	70.10	34.56
C/I = 7dB	5.74	62.84	32.72	49.80	31.76	49.48	33.86	33.54	39.04
C/I = 10dB	32.12	33.98	32.80	31.98	52.46				
C/I = 13dB	31.26	31.48	41.22						
C/I = 16dB	32.12								
error free	51.20	32.22							
RSSI = -100dBm	25.56								34.54

**Table C.8b: 95th percentiles of MSD transmission times for profile 4
(updated modem version [29])**

Condition	GSM FR	AMR 12.2	AMR 10.2	AMR 7.95	AMR 7.4	AMR 6.7	AMR 5.9	AMR 5.15	AMR 4.75
C/I = 1dB									15.00
C/I = 4dB							10.02	12.18	13.04
C/I = 7dB	10.60	7.80	10.20	6.56	6.94	11.04	10.28	11.80	13.40
C/I = 10dB	10.22	7.76	7.74	7.84	7.68				
C/I = 13dB	9.00	6.50	7.78						
C/I = 16dB	5.70								
error free	2.46	2.46							
RSSI = -100dBm	7.40								12.60

**Table C.9a: Average MSD transmission times for dynamic jitter buffer with delay and error profile 5
(original modem version [27])**

Condition	GSM FR	AMR 12.2	AMR 10.2	AMR 7.95	AMR 7.4	AMR 6.7	AMR 5.9	AMR 5.15	AMR 4.75
C/I = 1dB									15.13
C/I = 4dB							14.21	14.46	14.51
C/I = 7dB	13.31	11.68	12.14	12.17	10.76	13.10	13.01	12.69	14.25
C/I = 10dB	12.62	13.99	13.30	12.17	11.91				
C/I = 13dB	11.01	9.86	11.61						
C/I = 16dB	11.40								
error free	11.40	11.99							
RSSI = -100dBm	13.48								14.13

**Table C.9b: Average MSD transmission times for dynamic jitter buffer with delay and error profile 5
(updated modem version [29])**

Condition	GSM FR	AMR 12.2	AMR 10.2	AMR 7.95	AMR 7.4	AMR 6.7	AMR 5.9	AMR 5.15	AMR 4.75
C/I = 1dB									9.56
C/I = 4dB							6.92	8.40	8.75
C/I = 7dB	5.90	5.97	5.62	5.90	5.79	6.24	6.39	7.58	7.98
C/I = 10dB	5.29	5.46	5.64	5.54	5.55				
C/I = 13dB	5.23	4.98	5.03						
C/I = 16dB	5.33								
error free	4.58	4.29							
RSSI = -100dBm	5.32								8.21

**Table C.10a: 95th percentiles of MSD transmission times for profile 5
(original modem version [27])**

Condition	GSM FR	AMR 12.2	AMR 10.2	AMR 7.95	AMR 7.4	AMR 6.7	AMR 5.9	AMR 5.15	AMR 4.75
C/I = 1dB									33.34
C/I = 4dB							25.00	25.04	25.00
C/I = 7dB	32.04	24.30	31.90	23.70	15.90	24.28	24.50	16.26	25.02
C/I = 10dB	24.64	32.60	32.32	24.10	21.48				
C/I = 13dB	21.12	13.26	24.16						
C/I = 16dB	23.60								
error free	24.16	18.40							
RSSI = -100dBm	31.58								24.70

**Table C.10b: 95th percentiles of MSD transmission times for profile 5
(updated modem version [29])**

Condition	GSM FR	AMR 12.2	AMR 10.2	AMR 7.95	AMR 7.4	AMR 6.7	AMR 5.9	AMR 5.15	AMR 4.75
C/I = 1dB									17.66
C/I = 4dB							10.02	15.82	15.82
C/I = 7dB	10.26	8.56	8.70	8.22	8.10	8.70	8.92	10.04	10.44
C/I = 10dB	7.80	7.80	7.80	7.78	7.80				
C/I = 13dB	7.58	8.24	7.64						
C/I = 16dB	7.78								
error free	5.16	4.72							
RSSI = -100dBm	7.38								10.98

**Table C.11a: Average MSD transmission times for dynamic jitter buffer with delay and error profile 6
(original modem version [27])**

Condition	GSM FR	AMR 12.2	AMR 10.2	AMR 7.95	AMR 7.4	AMR 6.7	AMR 5.9	AMR 5.15	AMR 4.75
C/I = 1dB									6.57
C/I = 4dB							3.12	5.14	4.08
C/I = 7dB	2.94	2.39	1.87	1.75	1.74	2.19	2.33	3.13	4.57
C/I = 10dB	2.58	2.44	2.29	2.14	1.91				
C/I = 13dB	1.63	2.56	1.60						
C/I = 16dB	1.91								
error free	1.77	2.03							
RSSI = -100dBm	1.73								3.96

**Table C.11b: Average MSD transmission times for dynamic jitter buffer with delay and error profile 6
(updated modem version [29])**

Condition	GSM FR	AMR 12.2	AMR 10.2	AMR 7.95	AMR 7.4	AMR 6.7	AMR 5.9	AMR 5.15	AMR 4.75
C/I = 1dB									5.19
C/I = 4dB							2.94	3.70	4.07
C/I = 7dB	2.71	2.41	2.18	2.08	2.13	2.56	2.60	3.18	3.73
C/I = 10dB	2.00	1.90	1.82	1.92	1.93				
C/I = 13dB	1.90	1.78	1.83						
C/I = 16dB	1.77								
error free	1.66	1.65							
RSSI = -100dBm	1.87								3.69

**Table C.12a: 95th percentiles of MSD transmission times for profile 6
(original modem version [27])**

Condition	GSM FR	AMR 12.2	AMR 10.2	AMR 7.95	AMR 7.4	AMR 6.7	AMR 5.9	AMR 5.15	AMR 4.75
C/I = 1dB									32.64
C/I = 4dB							4.20	19.72	4.48
C/I = 7dB	4.38	3.10	1.80	2.14	2.42	3.48	3.80	4.34	13.56
C/I = 10dB	3.48	3.48	3.44	2.14	3.48				
C/I = 13dB	1.98	3.48	1.82						
C/I = 16dB	3.10								
error free	3.08	3.10							
RSSI = -100dBm	3.04								4.88

**Table C.12b: 95th percentiles of MSD transmission times for profile 6
(updated modem version [29])**

Condition	GSM FR	AMR 12.2	AMR 10.2	AMR 7.95	AMR 7.4	AMR 6.7	AMR 5.9	AMR 5.15	AMR 4.75
C/I = 1dB									7.68
C/I = 4dB							4.58	4.68	6.48
C/I = 7dB	4.50	2.90	2.48	2.46	2.96	4.14	2.90	4.50	4.68
C/I = 10dB	2.46	2.44	2.10	2.12	2.08				
C/I = 13dB	3.26	2.04	2.48						
C/I = 16dB	2.04								
error free	1.66	1.66							
RSSI = -100dBm	2.06								4.70

C.2 Transcoding

Table C.13: Average MSD transmission times for G.726 transcoding

Condition	GSM FR	AMR 12.2	AMR 10.2	AMR 7.95	AMR 7.4	AMR 6.7	AMR 5.9	AMR 5.15	AMR 4.75
C/I = 1dB									4.14
C/I = 4dB							2.53	3.17	3.37
C/I = 7dB	2.44	1.36	1.36	1.58	1.55	1.97	2.12	2.59	3.23
C/I = 10dB	1.83	2.20	1.91	1.72	1.68				
C/I = 13dB	1.59	1.55	1.40						
C/I = 16dB	1.53								
error free	1.69	1.36							
RSSI = -100dBm	1.43								3.03

Table C.14: 95th percentiles of MSD transmission times for G.726 transcoding

Condition	GSM FR	AMR 12.2	AMR 10.2	AMR 7.95	AMR 7.4	AMR 6.7	AMR 5.9	AMR 5.15	AMR 4.75
C/I = 1dB									4.95
C/I = 4dB						2.53	2.82	3.90	3.90
C/I = 7dB	4.05	1.37	1.36	1.74	1.97	2.12	2.44	3.14	3.90
C/I = 10dB	2.70	3.08	2.08	2.06					
C/I = 13dB	1.74	1.74	1.74						
C/I = 16dB	1.74								
error free	1.90	1.37							
RSSI = -100dBm	1.74								3.52

Table C.15: Average MSD transmission times for G.729B transcoding

Condition	GSM FR	AMR 12.2	AMR 10.2	AMR 7.95	AMR 7.4	AMR 6.7	AMR 5.9	AMR 5.15	AMR 4.75
C/I = 1dB									6.93
C/I = 4dB							4.39	5.61	5.93
C/I = 7dB	2.85	1.86	2.07	2.22	2.11	3.27	3.92	4.78	5.62
C/I = 10dB	2.26	2.82	2.54	2.36	2.26				
C/I = 13dB	2.08	2.13	2.09						
C/I = 16dB	2.01								
error free	2.11	1.77							
RSSI = -100dBm	1.96								5.48

Table C.16: 95th percentiles of MSD transmission times for G.729B transcoding

Condition	GSM FR	AMR 12.2	AMR 10.2	AMR 7.95	AMR 7.4	AMR 6.7	AMR 5.9	AMR 5.15	AMR 4.75
C/I = 1dB									8.56
C/I = 4dB						4.39	5.16	6.40	6.76
C/I = 7dB	4.44	2.10	2.10	2.46	3.27	3.92	4.24	5.68	6.40
C/I = 10dB	2.82	3.78	3.15	2.46					
C/I = 13dB	2.10	2.44	2.10						
C/I = 16dB	2.08								
error free	2.43	2.08							
RSSI = -100dBm	2.08								6.24

Table C.17: Average MSD transmission times for G.729I transcoding

Condition	GSM FR	AMR 12.2	AMR 10.2	AMR 7.95	AMR 7.4	AMR 6.7	AMR 5.9	AMR 5.15	AMR 4.75
C/I = 1dB									6.93
C/I = 4dB							4.39	5.61	5.93
C/I = 7dB	2.85	1.86	2.07	2.22	2.11	3.27	3.92	4.78	5.62
C/I = 10dB	2.26	2.82	2.54	2.36	2.26				
C/I = 13dB	2.08	2.13	2.09						
C/I = 16dB	2.01								
error free	2.11	1.77							
RSSI = -100dBm	1.96								5.48

Table C.18: 95th percentiles of MSD transmission times for G.729I transcoding

Condition	GSM FR	AMR 12.2	AMR 10.2	AMR 7.95	AMR 7.4	AMR 6.7	AMR 5.9	AMR 5.15	AMR 4.75
C/I = 1dB									8.56
C/I = 4dB						4.39	5.16	6.40	6.76
C/I = 7dB	4.44	2.10	2.10	2.46	3.27	3.92	4.24	5.69	6.40
C/I = 10dB	2.82	3.78	3.15	2.46					
C/I = 13dB	2.10	2.44	2.10						
C/I = 16dB	2.08								
error free	2.43	2.08							
RSSI = -100dBm	2.08								6.24

Table C.19a: Average MSD transmission times for G.729BA transcoding (original modem version [27])

Condition	GSM FR	AMR 12.2	AMR 10.2	AMR 7.95	AMR 7.4	AMR 6.7	AMR 5.9	AMR 5.15	AMR 4.75
C/I = 1dB									6.86
C/I = 4dB							4.42	5.52	5.91
C/I = 7dB	2.93	1.89	2.07	2.22	2.16	3.28	3.89	4.73	5.60
C/I = 10dB	2.24	3.01	2.53	2.40	2.32				
C/I = 13dB	2.04	2.16	2.10						
C/I = 16dB	1.99								
error free	2.12	1.78							
RSSI = -100dBm	1.93								5.52

Table C.19b: Average MSD transmission times for G.729BA transcoding (updated modem version [29])

Condition	GSM FR	AMR 12.2	AMR 10.2	AMR 7.95	AMR 7.4	AMR 6.7	AMR 5.9	AMR 5.15	AMR 4.75
C/I = 1dB									8.03
C/I = 4dB							4.93	6.34	6.78
C/I = 7dB	3.80	3.49	2.97	2.82	2.69	3.71	4.42	5.54	6.31

C/I = 10dB	2.55	2.43	2.40	2.62	2.54				
C/I = 13dB	2.36	2.13	2.38						
C/I = 16dB	2.30								
error free	2.27	2.03							
RSSI = -100dBm	2.42								6.46

Table C.20a: 95th percentiles of MSD transmission times for G.729BA transcoding (original modem version [27])

Condition	GSM FR	AMR 12.2	AMR 10.2	AMR 7.95	AMR 7.4	AMR 6.7	AMR 5.9	AMR 5.15	AMR 4.75
C/I = 1dB									8.22
C/I = 4dB						4.42	5.33	6.40	6.59
C/I = 7dB	4.58	2.10	2.10	2.46	3.28	3.89	4.24	5.68	6.40
C/I = 10dB	2.62	4.06	3.00	2.82					
C/I = 13dB	2.08	2.44	2.43						
C/I = 16dB	2.08								
error free	2.44	2.08							
RSSI = -100dBm	2.08								6.24

Table C.20b: 95th percentiles of MSD transmission times for G.729BA transcoding (updated modem version [29])

Condition	GSM FR	AMR 12.2	AMR 10.2	AMR 7.95	AMR 7.4	AMR 6.7	AMR 5.9	AMR 5.15	AMR 4.75
C/I = 1dB									9.44
C/I = 4dB							5.48	7.26	7.68
C/I = 7dB	5.78	4.90	3.70	3.30	2.86	4.18	5.04	6.80	7.68
C/I = 10dB	2.84	2.84	2.42	2.84	2.84				
C/I = 13dB	2.42	2.40	2.42						
C/I = 16dB	2.40								
error free	2.40	2.40							
RSSI = -100dBm	2.82								7.28

Table C.21: Average MSD transmission times for G.729A transcoding

Condition	GSM FR	AMR 12.2	AMR 10.2	AMR 7.95	AMR 7.4	AMR 6.7	AMR 5.9	AMR 5.15	AMR 4.75
C/I = 1dB									6.99
C/I = 4dB							4.33	5.56	5.91
C/I = 7dB	2.95	1.89	2.08	2.25	2.15	3.29	3.88	4.77	5.61
C/I = 10dB	2.23	2.99	2.57	2.40	2.30				
C/I = 13dB	2.03	2.14	2.09						
C/I = 16dB	1.99								
error free	2.12	1.80							
RSSI = -100dBm	1.96								5.52

Table C.22: 95th percentiles of MSD transmission times for G.729A transcoding

Condition	GSM FR	AMR 12.2	AMR 10.2	AMR 7.95	AMR 7.4	AMR 6.7	AMR 5.9	AMR 5.15	AMR 4.75
C/I = 1dB									8.30
C/I = 4dB						4.33	4.98	6.58	6.76
C/I = 7dB	4.82	2.10	2.10	2.46	3.29	3.88	4.24	6.06	6.40
C/I = 10dB	2.62	4.04	3.16	2.82					
C/I = 13dB	2.08	2.44	2.10						
C/I = 16dB	2.08								
error free	2.44	2.08							
RSSI = -100dBm	2.08								6.24

C.3 Sample slip

**Table C.23: Average MSD transmission times for sample slip scenario
'Simple shift left to right', handover period 2 s**

Condition	GSM FR	AMR 12.2	AMR 10.2	AMR 7.95	AMR 7.4	AMR 6.7	AMR 5.9	AMR 5.15	AMR 4.75
C/I = 1dB									8.09
C/I = 4dB							5.42	6.41	7.08
C/I = 7dB	4.72	3.92	4.01	4.33	4.47	4.83	5.24	6.05	6.75
C/I = 10dB	4.26	4.56	4.39	4.31	4.48				
C/I = 13dB	4.34	4.06	4.09						
C/I = 16dB	4.27								
error free	4.26	4.20							
RSSI = -100dBm	4.04								6.62

**Table C.24: 95th percentiles of MSD transmission times for sample slip scenario
'Simple shift left to right', handover period 2 s**

Condition	GSM FR	AMR 12.2	AMR 10.2	AMR 7.95	AMR 7.4	AMR 6.7	AMR 5.9	AMR 5.15	AMR 4.75
C/I = 1dB									10.66
C/I = 4dB						5.42	6.30	7.90	8.10
C/I = 7dB	6.20	4.50	4.50	4.86	4.83	5.24	5.94	6.32	8.08
C/I = 10dB	4.84	5.56	4.86	4.86					
C/I = 13dB	4.50	4.86	4.50						
C/I = 16dB	4.50								
error free	4.50	4.50							
RSSI = -100dBm	4.50								7.90

**Table C.25: Average MSD transmission times for sample slip scenario
'Simple shift left to right', handover period 5 s**

Condition	GSM FR	AMR 12.2	AMR 10.2	AMR 7.95	AMR 7.4	AMR 6.7	AMR 5.9	AMR 5.15	AMR 4.75
C/I = 1dB									6.68
C/I = 4dB							4.52	5.25	5.79
C/I = 7dB	4.23	3.40	3.45	3.79	3.70	4.11	4.28	4.96	5.39
C/I = 10dB	3.84	4.01	3.84	3.77	3.84				
C/I = 13dB	3.80	3.54	3.50						
C/I = 16dB	3.69								
error free	3.79	3.72							
RSSI = -100dBm	3.52								5.39

**Table C.26: 95th percentiles of MSD transmission times for sample slip scenario
'Simple shift left to right', handover period 5 s**

Condition	GSM FR	AMR 12.2	AMR 10.2	AMR 7.95	AMR 7.4	AMR 6.7	AMR 5.9	AMR 5.15	AMR 4.75
C/I = 1dB									8.48
C/I = 4dB						4.52	5.04	6.14	6.32
C/I = 7dB	5.62	3.78	5.78	4.16	4.11	4.28	4.84	5.40	6.30
C/I = 10dB	4.48	4.88	4.48	4.16					
C/I = 13dB	4.14	4.16	4.14						
C/I = 16dB	4.14								
error free	4.16	3.78							
RSSI = -100dBm	3.78								6.12

**Table C.27: Average MSD transmission times for sample slip scenario
'Simple shift left to right', handover period 10 s**

Condition	GSM FR	AMR 12.2	AMR 10.2	AMR 7.95	AMR 7.4	AMR 6.7	AMR 5.9	AMR 5.15	AMR 4.75
C/I = 1dB									6.44
C/I = 4dB							4.52	5.24	5.78
C/I = 7dB	4.22	3.40	3.45	3.79	3.70	4.11	4.28	4.99	5.39
C/I = 10dB	3.84	4.01	3.84	3.96	3.84				
C/I = 13dB	3.79	3.54	3.50						
C/I = 16dB	3.69								
error free	3.79	3.88							
RSSI = -100dBm	3.52								5.39

**Table C.28: 95th percentiles of MSD transmission times for sample slip scenario
'Simple shift left to right', handover period 10 s**

Condition	GSM FR	AMR 12.2	AMR 10.2	AMR 7.95	AMR 7.4	AMR 6.7	AMR 5.9	AMR 5.15	AMR 4.75
C/I = 1dB									7.66
C/I = 4dB						4.52	5.04	6.14	6.32
C/I = 7dB	5.62	3.78	3.78	4.16	4.11	4.28	4.84	5.40	6.30
C/I = 10dB	4.48	4.88	4.48	4.16					
C/I = 13dB	4.14	4.16	4.14						
C/I = 16dB	4.14								
error free	4.16	3.78							
RSSI = -100dBm	5.78								6.12

**Table C.29: Average MSD transmission times for sample slip scenario
'Double shift left to right', handover period 2 s**

Condition	GSM FR	AMR 12.2	AMR 10.2	AMR 7.95	AMR 7.4	AMR 6.7	AMR 5.9	AMR 5.15	AMR 4.75
C/I = 1dB									16.06
C/I = 4dB							8.21	9.29	9.78
C/I = 7dB	7.45	5.53	5.74	5.84	6.00	6.49	7.57	8.70	9.32
C/I = 10dB	6.34	7.16	6.40	5.83	6.15				
C/I = 13dB	6.20	5.59	5.70						
C/I = 16dB	5.96								
error free	5.86	5.81							
RSSI = -100dBm	5.68								9.32

**Table C.30: 95th percentiles of MSD transmission times for sample slip scenario
'Double shift left to right', handover period 2 s**

Condition	GSM FR	AMR 12.2	AMR 10.2	AMR 7.95	AMR 7.4	AMR 6.7	AMR 5.9	AMR 5.15	AMR 4.75
C/I = 1dB									38.12
C/I = 4dB						8.21	8.86	11.38	11.72
C/I = 7dB	9.38	5.98	7.98	6.34	6.49	7.57	8.50	9.22	11.38
C/I = 10dB	7.50	9.06	8.14	6.34					
C/I = 13dB	5.98	6.32	6.32						
C/I = 16dB	5.98								
error free	5.98	5.98							
RSSI = -100dBm	5.98								11.38

**Table C.31: Average MSD transmission times for sample slip scenario
'Double shift left to right', handover period 5 s**

Condition	GSM FR	AMR 12.2	AMR 10.2	AMR 7.95	AMR 7.4	AMR 6.7	AMR 5.9	AMR 5.15	AMR 4.75
-----------	-----------	-------------	-------------	-------------	------------	------------	------------	-------------	-------------

C/I = 1dB									8.70
C/I = 4dB							5.18	5.96	6.88
C/I = 7dB	5.23	3.97	4.04	4.21	4.25	4.58	4.75	5.23	6.15
C/I = 10dB	4.43	4.54	4.56	4.29	4.45				
C/I = 13dB	4.51	4.12	4.09						
C/I = 16dB	4.24								
error free	4.26	4.26							
RSSI = -100dBm	4.07								6.15

Table C.32: 95th percentiles of MSD transmission times for sample slip scenario 'Double shift left to right', handover period 5 s

Condition	GSM FR	AMR 12.2	AMR 10.2	AMR 7.95	AMR 7.4	AMR 6.7	AMR 5.9	AMR 5.15	AMR 4.75
C/I = 1dB									9.86
C/I = 4dB						5.18	5.62	8.86	8.88
C/I = 7dB	9.10	4.18	4.18	4.56	4.58	4.75	5.24	5.62	8.88
C/I = 10dB	4.92	5.28	4.90	4.56					
C/I = 13dB	4.54	4.56	4.54						
C/I = 16dB	5.54								
error free	4.56	4.18							
RSSI = -100dBm	4.18								8.86

Table C.33: Average MSD transmission times for sample slip scenario 'Double shift left to right', handover period 10 s

Condition	GSM FR	AMR 12.2	AMR 10.2	AMR 7.95	AMR 7.4	AMR 6.7	AMR 5.9	AMR 5.15	AMR 4.75
C/I = 1dB									7.05
C/I = 4dB							5.09	5.71	6.16
C/I = 7dB	5.15	3.97	4.04	4.21	4.25	4.58	4.75	5.20	6.03
C/I = 10dB	4.43	4.52	4.56	4.29	4.45				
C/I = 13dB	4.31	4.12	4.09						
C/I = 16dB	4.40								
error free	4.26	4.25							
RSSI = -100dBm	4.07								5.86

Table C.34: 95th percentiles of MSD transmission times for sample slip scenario 'Double shift left to right', handover period 10 s

Condition	GSM FR	AMR 12.2	AMR 10.2	AMR 7.95	AMR 7.4	AMR 6.7	AMR 5.9	AMR 5.15	AMR 4.75
C/I = 1dB									7.90
C/I = 4dB						5.09	5.62	6.70	6.72
C/I = 7dB	7.30	4.18	4.18	4.56	4.58	4.75	5.24	5.62	6.70
C/I = 10dB	4.92	5.28	4.90	4.56					
C/I = 13dB	4.54	4.56	4.54						
C/I = 16dB	4.54								
error free	4.56	4.18							
RSSI = -100dBm	4.18								6.34

Table C.35: Average MSD transmission times for sample slip scenario 'Simple shift right to left', handover period 2 s

Condition	GSM FR	AMR 12.2	AMR 10.2	AMR 7.95	AMR 7.4	AMR 6.7	AMR 5.9	AMR 5.15	AMR 4.75
C/I = 1dB									11.48
C/I = 4dB							6.33	8.03	8.35
C/I = 7dB	5.76	3.85	3.79	3.99	4.43	5.72	5.68	6.62	8.41
C/I = 10dB	4.53	4.92	4.66	4.30	4.11				
C/I = 13dB	4.41	4.11	3.85						

C/I = 16dB	4.05								
error free	4.17	3.65							
RSSI = -100dBm	3.68								7.70

Table C.36: 95th percentiles of MSD transmission times for sample slip scenario 'Simple shift right to left', handover period 2 s

Condition	GSM FR	AMR 12.2	AMR 10.2	AMR 7.95	AMR 7.4	AMR 6.7	AMR 5.9	AMR 5.15	AMR 4.75
C/I = 1dB									20.52
C/I = 4dB						6.33	8.48	10.84	11.02
C/I = 7dB	8.94	5.98	5.98	5.98	5.72	5.68	7.96	8.88	9.22
C/I = 10dB	6.34	6.34	6.34	6.32					
C/I = 13dB	6.32	5.98	5.98						
C/I = 16dB	5.98								
error free	6.32	5.98							
RSSI = -100dBm	5.96								9.22

Table C.37: Average MSD transmission times for sample slip scenario 'Simple shift right to left', handover period 5 s

Condition	GSM FR	AMR 12.2	AMR 10.2	AMR 7.95	AMR 7.4	AMR 6.7	AMR 5.9	AMR 5.15	AMR 4.75
C/I = 1dB									7.86
C/I = 4dB							4.42	5.48	6.22
C/I = 7dB	4.57	3.41	3.42	3.61	3.75	4.10	4.16	4.75	5.45
C/I = 10dB	3.74	4.11	3.90	3.77	3.74				
C/I = 13dB	3.79	3.49	3.49						
C/I = 16dB	3.52								
error free	3.61	3.29							
RSSI = -100dBm	3.41								5.73

Table C.38: 95th percentiles of MSD transmission times for sample slip scenario 'Simple shift right to left', handover period 5 s

Condition	GSM FR	AMR 12.2	AMR 10.2	AMR 7.95	AMR 7.4	AMR 6.7	AMR 5.9	AMR 5.15	AMR 4.75
C/I = 1dB									9.66
C/I = 4dB						4.42	5.26	8.50	8.88
C/I = 7dB	6.06	4.18	4.18	4.56	4.10	4.16	4.90	5.62	8.86
C/I = 10dB	4.72	4.92	4.90	4.56					
C/I = 13dB	4.54	4.56	4.18						
C/I = 16dB	4.54								
error free	4.54	4.18							
RSSI = -100dBm	4.18								8.68

Table C.39: Average MSD transmission times for sample slip scenario 'Simple shift right to left', handover period 10 s

Condition	GSM FR	AMR 12.2	AMR 10.2	AMR 7.95	AMR 7.4	AMR 6.7	AMR 5.9	AMR 5.15	AMR 4.75
C/I = 1dB									6.65
C/I = 4dB							4.42	5.34	5.74
C/I = 7dB	4.36	3.41	3.42	3.61	3.74	4.10	4.16	4.75	5.37
C/I = 10dB	3.74	4.09	3.89	3.77	3.74				
C/I = 13dB	3.77	3.49	3.49						
C/I = 16dB	3.52								
error free	3.61	3.29							
RSSI = -100dBm	3.41								5.52

Table C.40: 95th percentiles of MSD transmission times for sample slip scenario 'Simple shift right to left', handover period 10 s

Condition	GSM FR	AMR 12.2	AMR 10.2	AMR 7.95	AMR 7.4	AMR 6.7	AMR 5.9	AMR 5.15	AMR 4.75
C/I = 1dB									7.90
C/I = 4dB						4.42	5.26	6.34	6.72
C/I = 7dB	6.06	4.18	4.18	4.56	4.10	4.16	4.90	5.62	6.34
C/I = 10dB	4.72	4.92	4.90	4.56					
C/I = 13dB	4.54	4.56	4.18						
C/I = 16dB	4.54								
error free	4.54	4.18							
RSSI = -100dBm	4.18								6.34

Table C.41: Average MSD transmission times for sample slip scenario 'Double shift right to left', handover period 2 s

Condition	GSM FR	AMR 12.2	AMR 10.2	AMR 7.95	AMR 7.4	AMR 6.7	AMR 5.9	AMR 5.15	AMR 4.75
C/I = 1dB									10.84
C/I = 4dB							6.18	7.51	7.68
C/I = 7dB	5.05	3.87	3.67	4.10	4.08	5.17	5.55	6.61	7.69
C/I = 10dB	4.35	5.00	4.47	4.28	4.14				
C/I = 13dB	4.14	3.97	3.79						
C/I = 16dB	3.97								
error free	4.09	3.67							
RSSI = -100dBm	3.63								7.57

Table C.42: 95th percentiles of MSD transmission times for sample slip scenario 'Double shift right to left', handover period 2 s

Condition	GSM FR	AMR 12.2	AMR 10.2	AMR 7.95	AMR 7.4	AMR 6.7	AMR 5.9	AMR 5.15	AMR 4.75
C/I = 1dB									21.94
C/I = 4dB						6.18	8.48	9.22	9.22
C/I = 7dB	8.70	5.98	5.98	5.98	5.17	5.55	6.34	8.88	9.22
C/I = 10dB	5.98	6.34	6.34	6.14					
C/I = 13dB	5.98	5.98	5.98						
C/I = 16dB	5.98								
error free	5.98	5.98							
RSSI = -100dBm	5.96								9.22

Table C.43: Average MSD transmission times for sample slip scenario 'Double shift right to left', handover period 5 s

Condition	GSM FR	AMR 12.2	AMR 10.2	AMR 7.95	AMR 7.4	AMR 6.7	AMR 5.9	AMR 5.15	AMR 4.75
C/I = 1dB									7.35
C/I = 4dB							4.29	5.19	6.12
C/I = 7dB	4.24	3.34	3.34	3.55	3.45	4.04	4.04	4.61	5.34
C/I = 10dB	3.70	4.11	3.69	3.67	3.70				
C/I = 13dB	3.69	3.43	3.39						
C/I = 16dB	3.49								
error free	3.58	3.32							
RSSI = -100dBm	3.28								5.46

Table C.44: 95th percentiles of MSD transmission times for sample slip scenario 'Double shift right to left', handover period 5 s

Condition	GSM FR	AMR 12.2	AMR 10.2	AMR 7.95	AMR 7.4	AMR 6.7	AMR 5.9	AMR 5.15	AMR 4.75

	FR	12.2	10.2	7.95	7.4	6.7	5.9	5.15	4.75
C/I = 1dB									9.28
C/I = 4dB						4.29	5.24	7.80	8.86
C/I = 7dB	6.06	4.18	4.18	4.56	4.04	4.04	4.90	5.62	8.48
C/I = 10dB	4.56	4.92	4.90	4.56					
C/I = 13dB	4.54	4.54	4.18						
C/I = 16dB	4.36								
error free	4.56	4.18							
RSSI = -100dBm	4.16								7.78

**Table C.45: Average MSD transmission times for sample slip scenario
'Double shift right to left', handover period 10 s**

Condition	GSM FR	AMR 12.2	AMR 10.2	AMR 7.95	AMR 7.4	AMR 6.7	AMR 5.9	AMR 5.15	AMR 4.75
C/I = 1dB									6.40
C/I = 4dB							4.29	5.09	5.80
C/I = 7dB	4.22	3.34	3.34	3.55	3.45	4.04	4.04	4.61	5.19
C/I = 10dB	3.70	4.07	3.69	3.87	3.69				
C/I = 13dB	3.68	3.43	3.39						
C/I = 16dB	3.49								
error free	3.58	3.32							
RSSI = -100dBm	3.28								5.39

**Table C.46: 95th percentiles of MSD transmission times for sample slip scenario
'Double shift right to left', handover period 10 s**

Condition	GSM FR	AMR 12.2	AMR 10.2	AMR 7.95	AMR 7.4	AMR 6.7	AMR 5.9	AMR 5.15	AMR 4.75
C/I = 1dB									7.66
C/I = 4dB						4.29	5.24	6.32	6.72
C/I = 7dB	6.06	4.18	4.18	4.56	4.04	4.04	4.90	5.62	6.34
C/I = 10dB	4.56	4.92	4.88	4.56					
C/I = 13dB	4.54	4.54	4.18						
C/I = 16dB	4.36								
error free	4.56	4.18							
RSSI = -100dBm	4.16								6.32

C.4 CSoHS with transcoding (G.729a / G.711) and echo cancellation

**Table C.47: Average MSD transmission times with G.711 transcoding,
CSoHS jitter buffer (length 40 ms; delay/jitter profile 3), and echo canceller**

Condition	GSM FR	AMR 12.2	AMR 10.2	AMR 7.95	AMR 7.4	AMR 6.7	AMR 5.9	AMR 5.15	AMR 4.75
C/I = 1dB									4.87
C/I = 4dB							2.90	3.86	3.99
C/I = 7dB	2.35	2.13	1.89	1.81	1.75	2.21	2.41	3.47	3.89
C/I = 10dB	1.90	1.66	1.59	1.81	1.72				
C/I = 13dB	1.74	1.37	1.49						
C/I = 16dB	1.73								
error free	1.75	1.50							
RSSI = -100dBm	1.87								3.89

Table C.48: 95th percentiles of MSD transmission times with G.711 transcoding, CSoHS jitter buffer (length 40 ms; delay/jitter profile 3), and echo canceller

Condition	GSM FR	AMR 12.2	AMR 10.2	AMR 7.95	AMR 7.4	AMR 6.7	AMR 5.9	AMR 5.15	AMR 4.75
C/I = 1dB									6,06
C/I = 4dB						2,90	3,52	4,24	4,42
C/I = 7dB	3,68	3,51	2,08	2,08	2,21	2,41	2,44	3,91	4,24
C/I = 10dB	2,08	2,06	1,74	2,08					
C/I = 13dB	1,74	1,38	1,74						
C/I = 16dB	1,74								
error free	2,06	1,74							
RSSI = -100dBm	2,08								4,24

Table C.49: Average MSD transmission times with G.711 transcoding, CSoHS jitter buffer (length 40 ms; delay/jitter profile 4), and echo canceller

Condition	GSM FR	AMR 12.2	AMR 10.2	AMR 7.95	AMR 7.4	AMR 6.7	AMR 5.9	AMR 5.15	AMR 4.75
C/I = 1dB									4.82
C/I = 4dB							2.80	3.83	3.99
C/I = 7dB	2.30	2.15	1.91	1.80	1.78	2.18	2.36	3.35	3.91
C/I = 10dB	1.90	1.62	1.51	1.72	1.72				
C/I = 13dB	1.73	1.36	1.40						
C/I = 16dB	1.72								
error free	1.72	1.36							
RSSI = -100dBm	1.76								3.80

Table C.50: 95th percentiles of MSD transmission times with G.711 transcoding, CSoHS jitter buffer (length 40 ms; delay/jitter profile 4), and echo canceller

Condition	GSM FR	AMR 12.2	AMR 10.2	AMR 7.95	AMR 7.4	AMR 6.7	AMR 5.9	AMR 5.15	AMR 4.75
C/I = 1dB									5.87
C/I = 4dB						2.80	3.52	4.41	4.60
C/I = 7dB	3.68	3.51	2.08	2.08	2.18	2.36	2.44	3.90	4.24
C/I = 10dB	2.08	1.76	1.74	1.74					
C/I = 13dB	1.74	1.38	1.74						
C/I = 16dB	1.74								
error free	1.74	1.38							
RSSI = -100dBm	2.06								4.24

Table C.51: Average MSD transmission times with G.711 transcoding, CSoHS jitter buffer (length 40 ms; delay/jitter profile 5), and echo canceller

Condition	GSM FR	AMR 12.2	AMR 10.2	AMR 7.95	AMR 7.4	AMR 6.7	AMR 5.9	AMR 5.15	AMR 4.75
C/I = 1dB									4.79
C/I = 4dB							2.82	3.83	3.99
C/I = 7dB	2.30	2.16	1.88	1.80	1.75	2.17	2.40	3.35	3.86
C/I = 10dB	1.90	1.62	1.51	1.73	1.72				
C/I = 13dB	1.73	1.36	1.40						
C/I = 16dB	1.72								
error free	1.72	1.36							
RSSI = -100dBm	1.76								3.83

Table C.52: 95th percentiles of MSD transmission times with G.711 transcoding, CSoHS jitter buffer (length 40 ms; delay/jitter profile 5), and echo canceller

Condition	GSM FR	AMR 12.2	AMR 10.2	AMR 7.95	AMR 7.4	AMR 6.7	AMR 5.9	AMR 5.15	AMR 4.75
-----------	--------	----------	----------	----------	---------	---------	---------	----------	----------

C/I = 1dB									5.68
C/I = 4dB						2.82	3.52	4.41	4.60
C/I = 7dB	3.68	1.76	2.08	2.08	2.17	2.40	2.44	3.90	4.24
C/I = 10dB	2.08	1.38	1.74	1.76					
C/I = 13dB	1.74		1.74						
C/I = 16dB	1.74	1.37							
error free	1.74								
RSSI = -100dBm	2.06								4.24

Table C.53: Average MSD transmission times with G.711 transcoding, CSoHS jitter buffer (length 40 ms; delay/jitter profile 6), and echo canceller

Condition	GSM FR	AMR 12.2	AMR 10.2	AMR 7.95	AMR 7.4	AMR 6.7	AMR 5.9	AMR 5.15	AMR 4.75
C/I = 1dB									4.79
C/I = 4dB							2.82	3.83	3.99
C/I = 7dB	2.30	2.16	1.88	1.80	1.75	2.19	2.36	3.35	3.86
C/I = 10dB	1.90	1.62	1.51	1.73	1.72				
C/I = 13dB	1.75	1.36	1.40						
C/I = 16dB	1.73								
error free	1.72	1.36							
RSSI = -100dBm	1.76								3.82

Table C.54: 95th percentiles of MSD transmission times with G.711 transcoding, CSoHS jitter buffer (length 40 ms; delay/jitter profile 6), and echo canceller

Condition	GSM FR	AMR 12.2	AMR 10.2	AMR 7.95	AMR 7.4	AMR 6.7	AMR 5.9	AMR 5.15	AMR 4.75
C/I = 1dB									5.68
C/I = 4dB						2.82	3.52	4.41	4.60
C/I = 7dB	3.86	3.51	2.08	2.08	2.19	2.36	2.44	3.90	4.24
C/I = 10dB	2.08	1.76	1.74	1.76					
C/I = 13dB	2.06	1.38	1.74						
C/I = 16dB	1.74								
error free	1.74	1.37							
RSSI = -100dBm	2.06								4.24

Table C.55: Average MSD transmission times with G.729a transcoding, CSoHS jitter buffer (length 40 ms; delay/jitter profile 3), and echo canceller

Condition	GSM FR	AMR 12.2	AMR 10.2	AMR 7.95	AMR 7.4	AMR 6.7	AMR 5.9	AMR 5.15	AMR 4.75
C/I = 1dB									9.98
C/I = 4dB							5.13	7.01	7.31
C/I = 7dB	3.96	3.75	3.33	2.88	2.51	3.99	4.35	6.13	6.83
C/I = 10dB	3.04	2.43	2.50	2.53	2.41				
C/I = 13dB	2.65	2.10	2.42						
C/I = 16dB	2.49								
error free	2.42	2.12							
RSSI = -100dBm	2.68								6.63

Table C.56: 95th percentiles of MSD transmission times with G.729a transcoding, CSoHS jitter buffer (length 40 ms; delay/jitter profile 3), and echo canceller

Condition	GSM FR	AMR 12.2	AMR 10.2	AMR 7.95	AMR 7.4	AMR 6.7	AMR 5.9	AMR 5.15	AMR 4.75
C/I = 1dB									18.26
C/I = 4dB						5.13	6.07	8.23	8.56
C/I = 7dB	5.84	5.13	3.91	3.52	3.99	4.35	4.98	6.76	8.22
C/I = 10dB	3.71	2.82	2.82	3.16					
C/I = 13dB	3.16	2.44	2.46						

C/I = 16dB	2.82								
error free	2.44	2.44							
RSSI = -100dBm	3.52								7.66

Table C.57: Average MSD transmission times with G.729a transcoding, CSoHS jitter buffer (length 40 ms; delay/jitter profile 4), and echo canceller

Condition	GSM FR	AMR 12.2	AMR 10.2	AMR 7.95	AMR 7.4	AMR 6.7	AMR 5.9	AMR 5.15	AMR 4.75
C/I = 1dB									9.32
C/I = 4dB							5.09	6.69	7.09
C/I = 7dB	3.97	3.55	3.22	2.76	2.49	3.87	4.27	6.05	6.64
C/I = 10dB	2.94	2.36	2.46	2.50	2.37				
C/I = 13dB	2.53	2.06	2.37						
C/I = 16dB	2.44								
error free	2.41	2.04							
RSSI = -100dBm	2.62								6.71

Table C.58: 95th percentiles of MSD transmission times with G.729a transcoding, CSoHS jitter buffer (length 40 ms; delay/jitter profile 4), and echo canceller

Condition	GSM FR	AMR 12.2	AMR 10.2	AMR 7.95	AMR 7.4	AMR 6.7	AMR 5.9	AMR 5.15	AMR 4.75
C/I = 1dB									17.56
C/I = 4dB						5.09	6.06	8.30	8.24
C/I = 7dB	5.67	5.12	3.89	3.16	3.87	4.27	4.60	6.76	7.83
C/I = 10dB	3.90	2.82	2.82	2.84					
C/I = 13dB	2.82	2.10	2.46						
C/I = 16dB	2.46								
error free	2.44	2.10							
RSSI = -100dBm	3.16								7.83

Table C.59: Average MSD transmission times with G.729a transcoding, CSoHS jitter buffer (length 40 ms; delay/jitter profile 5), and echo canceller

Condition	GSM FR	AMR 12.2	AMR 10.2	AMR 7.95	AMR 7.4	AMR 6.7	AMR 5.9	AMR 5.15	AMR 4.75
C/I = 1dB									9.29
C/I = 4dB							5.02	6.65	7.01
C/I = 7dB	3.89	3.55	3.23	2.71	2.47	3.92	4.27	6.01	6.62
C/I = 10dB	2.87	2.36	2.43	2.50	2.36				
C/I = 13dB	2.50	2.06	2.39						
C/I = 16dB	2.45								
error free	2.43	2.03							
RSSI = -100dBm	2.64								6.59

Table C.60: 95th percentiles of MSD transmission times with G.729a transcoding, CSoHS jitter buffer (length 40 ms; delay/jitter profile 5), and echo canceller

Condition	GSM FR	AMR 12.2	AMR 10.2	AMR 7.95	AMR 7.4	AMR 6.7	AMR 5.9	AMR 5.15	AMR 4.75
C/I = 1dB									17.22
C/I = 4dB						5.02	6.06	8.12	8.22
C/I = 7dB	5.51	4.76	3.90	3.17	3.92	4.27	4.60	6.59	7.66
C/I = 10dB	3.52	2.82	2.81	2.84					
C/I = 13dB	2.82	2.10	2.46						
C/I = 16dB	2.46								
error free	2.44	2.10							
RSSI = -100dBm	3.16								7.48

Table C.61: Average MSD transmission times with G.729a transcoding, CSoHS jitter buffer (length 40 ms; delay/jitter profile 6), and echo canceller

Condition	GSM FR	AMR 12.2	AMR 10.2	AMR 7.95	AMR 7.4	AMR 6.7	AMR 5.9	AMR 5.15	AMR 4.75
C/I = 1dB									9.10
C/I = 4dB							5.03	6.66	7.04
C/I = 7dB	3.92	3.57	3.22	2.74	2.49	3.87	4.27	5.99	6.58
C/I = 10dB	2.86	2.36	2.43	2.50	2.36				
C/I = 13dB	2.51	2.06	2.37						
C/I = 16dB	2.45								
error free	2.41	2.04							
RSSI = -100dBm	2.62								6.50

Table C.62: 95th percentiles of MSD transmission times with G.729a transcoding, CSoHS jitter buffer (length 40 ms; delay/jitter profile 6), and echo canceller

Condition	GSM FR	AMR 12.2	AMR 10.2	AMR 7.95	AMR 7.4	AMR 6.7	AMR 5.9	AMR 5.15	AMR 4.75
C/I = 1dB									17.20
C/I = 4dB						5.03	6.06	8.12	8.30
C/I = 7dB	5.50	4.60	3.89	3.16	3.87	4.27	4.60	6.76	7.48
C/I = 10dB	3.71	2.82	2.81	2.84					
C/I = 13dB	2.82	2.10	2.46						
C/I = 16dB	2.46								
error free	2.44	2.10							
RSSI = -100dBm	3.16								7.14

Annex D: Change history

Change history							
Date	TSG #	TSG Doc.	CR	Rev	Subject/Comment	Old	New
06-2009	44	SP-090253			Presented at TSG SA#44 Plenary for information		1.0.0
09-2009	45	SP-090564			Presented at TSG SA#45 Plenary for approval	1.0.0	2.0.0.
09-2009	45				Approved at TSG SA#45 Plenary	2.0.0	8.0.0
12-2009	46	SP-090702	0001	2	Editorial corrections and clarifications of characterization test results	8.0.0	8.1.0
03-2011	51	SP-110033	0002	2	Update of characterization test results to latest eCall reference code version	8.1.0	8.2.0

History

Document history		
V8.0.0	October 2009	Publication
V8.1.0	January 2010	Publication
V8.2.0	April 2011	Publication