

ETSI TR 126 942 V19.0.0 (2026-01)



TECHNICAL REPORT

**5G;
Study on Media energy consumption exposuRE and
Evaluation framework
(3GPP TR 26.942 version 19.0.0 Release 19)**



Reference

DTR/TSGS-0426942vj00

Keywords

5G

ETSI

650 Route des Lucioles
F-06921 Sophia Antipolis Cedex - FRANCE

Tel.: +33 4 92 94 42 00 Fax: +33 4 93 65 47 16

Siret N° 348 623 562 00017 - APE 7112B
Association à but non lucratif enregistrée à la
Sous-Préfecture de Grasse (06) N° w061004871

Important notice

The present document can be downloaded from the
[ETSI Search & Browse Standards application](#).

The present document may be made available in electronic versions and/or in print. The content of any electronic and/or print versions of the present document shall not be modified without the prior written authorization of ETSI. In case of any existing or perceived difference in contents between such versions and/or in print, the prevailing version of an ETSI deliverable is the one made publicly available in PDF format on [ETSI deliver repository](#).

Users should be aware that the present document may be revised or have its status changed, this information is available in the [Milestones listing](#).

If you find errors in the present document, please send your comments to the relevant service listed under [Committee Support Staff](#).

If you find a security vulnerability in the present document, please report it through our [Coordinated Vulnerability Disclosure \(CVD\)](#) program.

Notice of disclaimer & limitation of liability

The information provided in the present deliverable is directed solely to professionals who have the appropriate degree of experience to understand and interpret its content in accordance with generally accepted engineering or other professional standard and applicable regulations.

No recommendation as to products and services or vendors is made or should be implied.

No representation or warranty is made that this deliverable is technically accurate or sufficient or conforms to any law and/or governmental rule and/or regulation and further, no representation or warranty is made of merchantability or fitness for any particular purpose or against infringement of intellectual property rights.

In no event shall ETSI be held liable for loss of profits or any other incidental or consequential damages.

Any software contained in this deliverable is provided "AS IS" with no warranties, express or implied, including but not limited to, the warranties of merchantability, fitness for a particular purpose and non-infringement of intellectual property rights and ETSI shall not be held liable in any event for any damages whatsoever (including, without limitation, damages for loss of profits, business interruption, loss of information, or any other pecuniary loss) arising out of or related to the use of or inability to use the software.

Copyright Notification

No part may be reproduced or utilized in any form or by any means, electronic or mechanical, including photocopying and microfilm except as authorized by written permission of ETSI.

The content of the PDF version shall not be modified without the written authorization of ETSI.

The copyright and the foregoing restriction extend to reproduction in all media.

© ETSI 2026.
All rights reserved.

Intellectual Property Rights

Essential patents

IPRs essential or potentially essential to normative deliverables may have been declared to ETSI. The declarations pertaining to these essential IPRs, if any, are publicly available for **ETSI members and non-members**, and can be found in ETSI SR 000 314: "*Intellectual Property Rights (IPRs); Essential, or potentially Essential, IPRs notified to ETSI in respect of ETSI standards*", which is available from the ETSI Secretariat. Latest updates are available on the [ETSI IPR online database](#).

Pursuant to the ETSI Directives including the ETSI IPR Policy, no investigation regarding the essentiality of IPRs, including IPR searches, has been carried out by ETSI. No guarantee can be given as to the existence of other IPRs not referenced in ETSI SR 000 314 (or the updates on the ETSI Web server) which are, or may be, or may become, essential to the present document.

Trademarks

The present document may include trademarks and/or tradenames which are asserted and/or registered by their owners. ETSI claims no ownership of these except for any which are indicated as being the property of ETSI, and conveys no right to use or reproduce any trademark and/or tradename. Mention of those trademarks in the present document does not constitute an endorsement by ETSI of products, services or organizations associated with those trademarks.

DECT™, **PLUGTESTS™**, **UMTS™** and the ETSI logo are trademarks of ETSI registered for the benefit of its Members. **3GPP™**, **LTE™** and **5G™** logo are trademarks of ETSI registered for the benefit of its Members and of the 3GPP Organizational Partners. **oneM2M™** logo is a trademark of ETSI registered for the benefit of its Members and of the oneM2M Partners. **GSM®** and the GSM logo are trademarks registered and owned by the GSM Association.

Legal Notice

This Technical Report (TR) has been produced by ETSI 3rd Generation Partnership Project (3GPP).

The present document may refer to technical specifications or reports using their 3GPP identities. These shall be interpreted as being references to the corresponding ETSI deliverables.

The cross reference between 3GPP and ETSI identities can be found at [3GPP to ETSI numbering cross-referencing](#).

Modal verbs terminology

In the present document "**should**", "**should not**", "**may**", "**need not**", "**will**", "**will not**", "**can**" and "**cannot**" are to be interpreted as described in clause 3.2 of the [ETSI Drafting Rules](#) (Verbal forms for the expression of provisions).

"**must**" and "**must not**" are **NOT** allowed in ETSI deliverables except when used in direct citation.

5.1	Baseline use cases defined by SA1.....	30
5.2	Additional use cases defined by 3GPP SA WG4	31
6	Key Issues	32
6.1	Key Issue #1: Energy-related Information exposure	32
6.1.1	Description.....	32
6.1.2	Potential requirements	32
6.2	Key Issue #2: Energy-related monitoring and measurement.....	33
6.2.1	Description.....	33
6.2.2	Potential requirements	34
6.3	Key Issue #3: Evaluation framework	35
6.3.1	Description.....	35
6.3.2	Potential requirements	36
7	Potential Solutions.....	37
7.1	Mapping of Solutions to Key Issues.....	37
7.2	Solution #1: Evaluation framework based on French regulators' work	37
7.2.1	Key Issue mapping.....	37
7.2.2	Functional description.....	37
7.2.3	Procedures.....	38
7.2.4	Summary.....	38
7.3	Solution #2: Evaluation Framework to measure energy efficiency of a UE.....	39
7.3.1	Key Issue mapping.....	39
7.3.2	Functional description.....	39
7.3.2.1	UE Energy Efficiency metric	39
7.3.3	Procedures.....	39
7.3.4	Summary.....	40
7.4	Solution #3: Existing UE energy-related information measurement.....	40
7.4.1	Key Issue mapping.....	40
7.4.2	Functional description.....	40
7.4.3	Summary.....	41
7.5	Solution #4: Energy-related information exposure from UE.....	41
7.5.1	Key Issue mapping.....	41
7.5.2	Functional description.....	41
7.5.2.1	Introduction	41
7.5.2.2	UE energy-related information collection and reporting functionality	42
7.5.2.2.1	Generic UE energy-related information collection and reporting.....	42
7.5.2.2.2	Instantiation of UE energy-related information collection and reporting in the 5G Media Streaming architecture	43
7.5.3	Procedures.....	44
7.5.4	Impacts on existing services, entities and interfaces.....	45
7.5.4.1	Direct Data Collection Client	45
7.5.4.2	Data Collection AF	45
7.6	Solution #5: Energy-related information from the network and other Service Provider entities provided to a UE application and Application Service Provider	45
7.6.1	Key Issue mapping.....	45
7.6.2	Functional description.....	45
7.6.2.1	Introduction	45
7.6.2.2	Generic reference architecture for collection and exposure of energy-related information	46
7.6.2.3	Instantiation in 5G Media Streaming architecture.....	48
7.6.2.4	Instantiation in generalised Media Delivery architecture.....	50
7.6.3	Procedures.....	51
7.6.3.1	Generic high-level procedures for collection and exposure of energy-related information	51
7.6.3.2	5GMS high-level procedures for collection and exposure of energy-related information	53
7.6.4	Summary.....	55
7.7	Solution #6: QMC-based monitoring and measurement	56
7.7.1	Key Issue mapping.....	56
7.7.2	Functional description.....	56
7.7.2.1	Introduction	56
7.7.2.2	MTSI Quality of Experience (QoE) metrics	56
7.7.2.3	DASH Quality of Experience (QoE) metrics	57
7.7.3	Procedures.....	58

7.7.3.1	Network-triggered QoE configuration	58
7.7.3.1.1	Introduction	58
7.7.3.1.2	Option 1: Adding Energy Consumption as a new flag in MTSI QoE reporting, relating to a specific media delivery session	58
7.7.3.1.3	Option 2: Dedicated QoE configuration for energy reporting only	59
7.7.4	Summary.....	59
7.8	Solution #7: Energy Information Exposure Specification for controlling exposure of Energy-related information to Application Service Provider.....	60
7.8.1	Key Issue mapping.....	60
7.8.2	Functional description.....	60
7.8.3	Procedures.....	60
7.9	Solution #8: UE application energy consumption measurement based on MTD technique.....	60
7.9.1	Key Issue mapping.....	60
7.9.2	Functional description.....	60
7.9.2.1	Introduction.....	60
7.9.2.2	Calculation of MTD	61
7.9.2.2.1	High-level description	61
7.9.2.2.2	UE battery consumption calculation.....	61
7.9.3	Procedures.....	62
7.9.4	Summary.....	62
7.10	Solution #9: UE energy metrics abstraction	63
7.10.1	Key Issue mapping.....	63
7.10.2	Functional description.....	63
7.10.2.1	Introduction.....	63
7.10.2.2	Energy-related information relevant to the UE	63
7.10.2.3	Estimating the energy usage of media applications running on the UE	64
7.10.2.4	UE energy information index abstraction	65
7.10.3	Procedures.....	65
7.10.4	Summary.....	65
8	Conclusions	66
8.1	General	66
8.2	Conclusion for Key Issue #1 (Energy-related information exposure).....	66
8.3	Conclusion for Key Issue #2 (Energy-related monitoring and measurement).....	67
8.4	Conclusion for Key Issue #3 (Evaluation framework)	68
9	Proposed next steps	68
Annex A:	Change history	70
History		71

Foreword

This Technical Report has been produced by the 3rd Generation Partnership Project (3GPP).

The contents of the present document are subject to continuing work within the TSG and may change following formal TSG approval. Should the TSG modify the contents of the present document, it will be re-released by the TSG with an identifying change of release date and an increase in version number as follows:

Version x.y.z

where:

- x the first digit:
 - 1 presented to TSG for information;
 - 2 presented to TSG for approval;
 - 3 or greater indicates TSG approved document under change control.
- y the second digit is incremented for all changes of substance, i.e. technical enhancements, corrections, updates, etc.
- z the third digit is incremented when editorial only changes have been incorporated in the document.

In the present document, modal verbs have the following meanings:

- shall** indicates a mandatory requirement to do something
- shall not** indicates an interdiction (prohibition) to do something

The constructions "shall" and "shall not" are confined to the context of normative provisions, and do not appear in Technical Reports.

The constructions "must" and "must not" are not used as substitutes for "shall" and "shall not". Their use is avoided insofar as possible, and they are not used in a normative context except in a direct citation from an external, referenced, non-3GPP document, or so as to maintain continuity of style when extending or modifying the provisions of such a referenced document.

- should** indicates a recommendation to do something
- should not** indicates a recommendation not to do something
- may** indicates permission to do something
- need not** indicates permission not to do something

The construction "may not" is ambiguous and is not used in normative elements. The unambiguous constructions "might not" or "shall not" are used instead, depending upon the meaning intended.

- can** indicates that something is possible
- cannot** indicates that something is impossible

The constructions "can" and "cannot" are not substitutes for "may" and "need not".

- will** indicates that something is certain or expected to happen as a result of action taken by an agency the behaviour of which is outside the scope of the present document
- will not** indicates that something is certain or expected not to happen as a result of action taken by an agency the behaviour of which is outside the scope of the present document
- might** indicates a likelihood that something will happen as a result of action taken by some agency the behaviour of which is outside the scope of the present document

might not indicates a likelihood that something will not happen as a result of action taken by some agency the behaviour of which is outside the scope of the present document

In addition:

is (or any other verb in the indicative mood) indicates a statement of fact

is not (or any other negative verb in the indicative mood) indicates a statement of fact

The constructions "is" and "is not" do not indicate requirements.

1 Scope

The present document identifies potential sustainable media metrics, architectural impacts (APIs), functional extensions required for media service enablers in the 5G system and evaluate the feasibility of an evaluation framework to facilitate efficient energy use and energy saving for media services.

2 References

The following documents contain provisions which, through reference in this text, constitute provisions of the present document.

- References are either specific (identified by date of publication, edition number, version number, etc.) or non-specific.
- For a specific reference, subsequent revisions do not apply.
- For a non-specific reference, the latest version applies. In the case of a reference to a 3GPP document (including a GSM document), a non-specific reference implicitly refers to the latest version of that document *in the same Release as the present document*.

- [1] 3GPP TR 21.905: "Vocabulary for 3GPP Specifications".
- [2] ETSI TS 28.310: "Management and orchestration; Energy efficiency of 5G".
- [3] ETSI EN 303 472: "Environmental Engineering (EE); Energy Efficiency measurement methodology and metrics for RAN equipment".
- [4] ETSI ES 202 706-1: "Environmental Engineering (EE); Metrics and measurement method for energy efficiency of wireless access network equipment; Part 1: Power consumption - static measurement method".
- [5] ETSI TS 22.261: "Service requirements for the 5G system".
- [6] D Lundén, J Malmodin, P Bergmark and N Lövehagen, "Electricity Consumption and Operational Carbon Emissions of European Telecom Network Operators", Sustainability 14(5):2637, 2022.
- [7] J Malmodin, "The power consumption of mobile and fixed network data services-The case of streaming video and downloading large files." Electronics Goes Green, 2020.
- [8] J Malmodin, N Lövehagen, P Bergmark and D Lundén, "ICT sector electricity consumption and greenhouse gas emissions – 2020 outcome", Telecommunications Policy (2024): 102701.
- [9] The Greenhouse Gas Protocol, <https://ghgprotocol.org>
- [10] The Greenhouse Gas Protocol, "A Corporate Accounting and Reporting Standard, Revised Edition"
- [11] The Greenhouse Gas Protocol: "Corporate Value Chain (Scope 3) Accounting and Reporting Standard: Supplement to the GHG Protocol Corporate Accounting and Reporting Standard".
- [12] The European Commission: "Commission Delegated Regulation (EU) 2023/2772", The Official Journal of the European Union, 23rd July 2023.
- [13] Ember Climate: "Global Electricity Review 2023", <https://ember-climate.org/insights/research/global-electricity-review-2023/>
- [14] 3GPP TR 28.913: "Study on new aspects of Energy Efficiency (EE) for 5G phase 2".
- [15] 3GPP TS 28.554: "5G end to end Key Performance Indicators (KPI)".
- [16] 3GPP TS 28.552: "Management and orchestration; 5G performance measurements".
- [17] 3GPP TS 28.533: "Management and orchestration; Architecture framework".

- [18] 3GPP TS 28.622: "Telecommunication management; Generic Network Resource Model (NRM) Integration Reference Point (IRP); Information Service (IS)".
- [19] 3GPP TS 28.532: "Management and orchestration; Generic management services".
- [20] 3GPP TR 23.700-66: "Study on Energy Efficiency and Energy Saving".
- [21] 3GPP TS 26.531: "Data collection and reporting; General description and architecture".
- [22] 3GPP TS 26.532: "Data Collection and Reporting; Protocols and Formats".
- [23] 3GPP TS 26.501: "5G Media Streaming (5GMS); General description and architecture".
- [24] 3GPP TS 26.247: "Transparent end-to-end Packet-switched Streaming Service (PSS); Progressive Download and Dynamic Adaptive Streaming over HTTP (3GP-DASH)".
- [25] 3GPP TS 38.300: "NR; NR and NG-RAN Overall description; Stage-2".
- [26] 3GPP TS 26.114: "IP Multimedia Subsystem (IMS); Multimedia telephony; Media handling and interaction"
- [27] 3GPP TS 26.118: "Virtual Reality (VR) profiles for streaming applications".
- [28] 3GPP TS 28.405: "Telecommunication management; Quality of Experience (QoE) measurement collection; Control and configuration".
- [29] International Telecommunication Union, Recommendation ITU-T L.1310: "Energy efficiency metrics and measurement methods for telecommunication equipment".
- [30] International Telecommunication Union, Series L Supplement 36, "ITU-T L.1310 – Study on methods and metrics to evaluate energy efficiency for future 5G systems", November 2017.
- [31] International Telecommunication Union, Recommendation ITU-T L.1450, "Methodologies for the assessment of the environmental impact of the information and communication technology sector", 9/2018
- [32] Jens Malmodin, Nina Lövehagen, Pernilla Bergmark, and Dag Lundén. "[ICT sector electricity consumption and greenhouse gas emissions–2020 outcome](#)." Telecommunications Policy (2024): 102701.
- [33] International Telecommunication Union, Report ITU-R BT.2385-1: "Reducing the environmental impact of terrestrial broadcasting systems", March 2022.
- [34] International Telecommunication Union, Opinion ITU-R OP.104: "Advice for sustainability strategies incorporating carbon offsetting policies", 2022.
- [35] International Telecommunication Union, Report ITU-R BT.2521-0, "Practical examples of actions to realize energy aware broadcasting", March 2023.
- [36] International Telecommunication Union, Report ITU-R BT.2540-0, "Display energy reduction through image signal processing", March 2024.
- [37] ISO/IEC 23001-11:2023: "Information technology, MPEG systems technologies, Part 11: Energy-efficient media consumption (green metadata)".
- [38] DVB, "Study Mission report on Energy Aware service Delivery and Consumption", DVB Document S100, November 2023.
- [39] ATSC Planning Team 9, <https://www.atsc.org/subcommittees/planning-team-9-sustainability/>
- [40] TS 23.502: "Procedures for the 5G System (5GS)".
- [41] ETSI ES 203 700: "Environmental Engineering (EE); Sustainable power feeding solutions for 5G network".
- [42] ETSI ES 203 539: "Environmental Engineering (EE); Measurement method for energy efficiency of Network Functions Virtualisation (NFV) in laboratory environment".

- [43] ETSI EN 303 470: "Environmental Engineering (EE); Energy Efficiency measurement methodology and metrics for servers".
- [44] ETSI EN 303 471: "Environmental Engineering (EE); Energy Efficiency measurement methodology and metrics for Network Function Virtualisation (NFV)".
- [45] ETSI ES 203 475: "Environmental Engineering (EE); Standardization terms and trends in energy efficiency".
- [46] ETSI ES 203 136: "Environmental Engineering (EE); Measurement methods for energy efficiency of router and switch equipment Update standard for Energy efficiency for router and switch equipment".
- [47] ETSI EN 303 215: "Environmental Engineering (EE); Measurement methods and limits for power consumption in broadband telecommunication networks equipment".
- [48] ETSI ES 203 184: "Environmental Engineering (EE); Measurement Methods for Power Consumption in Transport Telecommunication Networks Equipment".
- [49] ETSI EN 301 575: "Environmental Engineering (EE); Measurement method for energy consumption of Customer Premises Equipment (CPE)".
- [50] ETSI ES 203 215: "Environmental Engineering (EE); Measurement Methods and Limits for Power Consumption in Broadband Telecommunication Networks Equipment".
- [51] Greening of Streaming, <https://www.greeningofstreaming.org/>
- [52] DIMPACT, <https://dimpact.org/>
- [53] DIMPACT, "Methodology: Estimating the carbon impacts of serving digital media and entertainment products", version 1.0, October 2022.
- [54] DIMPACT, Draft paper "Literature review and policy principles for streaming and digital media carbon footprinting", March 2023.
- [55] Ultra HD Forum, <https://ultrahdforum.org/ibc2023-press-release-ultra-hd-forum-to-showcase-efficient-hdr-sdr-sustainability-demos/>
- [56] 3GPP TR 22.882: "Study on Energy Efficiency as a service criteria".
- [57] ARCEP, "Arcep publishes a draft decision for public consultation, with a view to enhancing its annual "Achieving digital sustainability" survey", https://en.arcep.fr/fileadmin/cru-1714402758/user_upload/41-24-english-version.pdf
- [58] 3GPP TS 26.502: "5G multicast-broadcast services; User service architecture".
- [59] 3GPP TS 26.506: "5G Real-time Media Communication Architecture".
- [60] Directive (EU) 2024/825: "amending Directives 2005/29/EC and 2011/83/EU as regards empowering consumers for the green transition through better protection against unfair practices and better information", 28th February 2024. <https://eur-lex.europa.eu/legal-content/EN/TXT/?uri=CELEX:32024L0825>
- [61] ARCEP, "Arcom and Arcep, in tandem with ADEME, publish an unprecedented study on the environmental impact of audiovisual media consumption in France in 2022, and up to 2030", https://en.arcep.fr/fileadmin/user_upload/57-24-english-version.pdf
- [62] 3GPP TR 26.955: "5G Video Codec Characteristics".
- [63] Android BatteryManager API, <https://developer.android.com/reference/kotlin/android/os/BatteryManager>
- [64] 3GPP TS 23.247: "Architectural enhancements for 5G multicast-broadcast services".
- [65] 3GPP TS 26.565: "Split Rendering Media Service Enabler".

- [66] ETSI ES 203 228: "Environmental Engineering (EE); Assessment of mobile network energy efficiency".
- [67] International Telecommunication Union, Recommendation ITU-T L.1331, "Assessment of mobile network energy efficiency", January 2022.
- [68] ETSI ES 202 336-12: "Environmental Engineering (EE); Monitoring and control interface for infrastructure equipment (power, cooling and building environment systems used in telecommunication networks); Part 12: ICT equipment power, energy and environmental parameters monitoring information model".
- [69] Harmony OS Battery information API,
<https://developer.huawei.com/consumer/en/doc/harmonyos-references/js-apis-battery-info-V5>
- [70] 3GPP TS 23.288: "Architecture enhancements for 5G System (5GS) to support network data analytics services".
- [71] 3GPP TS 26.947: "Multimedia Broadcast/Multicast Service (MBMS); Selection and characterisation of application layer Forward Error Correction (FEC)".
- [72] 3GPP TS 23.501: "System architecture for the 5G System (5GS) (Release 19)".
- [73] Mohit Arora and Ian McClenaghan, "Decarbonizing the media, broadcast, and streaming industry", *Joule*, volume 8, issue 4, April 2024, pp873–878.
- [74] Jigna Chandaria, "The Carbon Footprint of Watching Television", October 2011, available at <https://www.bbc.co.uk/rd/blog/2011-10-tv-carbon-footprint>
- [75] Jigna Chandaria, BBC R&D White Paper WHP 189, "A comparison of a Carbon Footprint of Digital Terrestrial Television with Video-On-Demand", January 2011 available at <https://www.bbc.co.uk/rd/publications/whitepaper189>
- [76] Arman Shehabi, Ben Walker and Eric Masanet, "The energy and greenhouse-gas implications of Internet video streaming in the United States", *Environmental Research Letters*, volume 9, number 5, May 2014 available at <https://iopscience.iop.org/article/10.1088/1748-9326/9/5/054007>
- [77] George Kamiya, "The carbon footprint of streaming video: fact-checking the headlines", December 2020, available at <https://www.iea.org/commentaries/the-carbon-footprint-of-streaming-video-fact-checking-the-headlines>
- [78] Jigna Chandaria, Natasha Westland and Chloe Fletcher, "How much energy is used to deliver and watch TV programmes?", September 2020, available at <https://www.bbc.co.uk/rd/blog/2020-09-sustainability-video-energy-streaming-broadcast>
- [79] Mohit Arora and Ian McClenaghan and Lydia Wozniak "Priorities for net-zero web services", *Nature Electronics*, issue 7, August 2024, pp.622–625, available at <https://doi.org/10.1038/s41928-024-01227-8>
- [80] Carbon Trust, "Carbon impact of video streaming", June 2021, available at <https://www.carbontrust.com/our-work-and-impact/guides-reports-and-tools/carbon-impact-of-video-streaming>
- [81] David Mytton, Dag Lundén, and Jens Malmodin, "Network energy use not directly proportional to data volume: The power model approach for more reliable network energy consumption calculations", *Journal of Industrial Ecology*, volume 28, June 2024, pp.966–980, available at <https://doi.org/10.1111/jiec.13512>
- [82] Ofcom, "Carbon emissions of streaming and digital terrestrial television", October 2022, available at <https://www.ofcom.org.uk/internet-based-services/technology/carbon-emissions-of-streaming-and-digital-terrestrial-television/>
- [83] "ADEME: The French ecological transition agency", <https://www.ademe.fr/en/ademe-the-french-ecological-transition-agency/>
- [84] Ben-Gan, Itzik. "Datetime calculations, Part 4: calculate first/last occurrences of a weekday in a month." *SQL Server Magazine* 9.5 (2007): pp19-22.

- [85] 3GPP TR 22.883: "Feasibility Study on Energy Efficiency as service criteria Phase 2".
- [86] "[Electrochemical Energy Storage for Renewable Sources and Grid Balancing](#)", 2015, pp. 411–435.
- [87] Accubattery: <https://play.google.com/store/apps/details?id=com.digibites.accubattery>

3 Definitions of terms, symbols and abbreviations

3.1 Terms

For the purposes of the present document, the terms given in TR 21.905 [1] and the following apply. A term defined in the present document takes precedence over the definition of the same term, if any, in TR 21.905 [1].

AS Energy Information: energy-related information collected and exposed by Application Servers.

carbon intensity: Global greenhouse gases emitted per unit of generated electricity, measured in grams of CO₂ equivalent per watt-hour intended for conversion to carbon emissions as defined in TS 22.261 [5] and TS 23.700-66 [20].

energy consumption: integral of power consumption over time, as defined in TS 28.310 [2].

energy credit: a quantity associated with the subscriber that can be used for credit control by the 5G System per TS 22.261 [5].

energy efficiency (EE): ratio between performance and energy consumption.

NOTE: The performance may be measured based on, e.g., data volume, latency, number of active users, etc. as defined in TS 28.310 [2].

maximum energy consumption: a policy establishing an upper bound on the quantity of energy consumption [2] by the 5G system in a specific period of time, or space, e.g. energy consumption inside a given service area as defined in ETSI ES 202 706-1 [4].

maximum energy credit limit: a policy establishing an upper bound on the aggregate quantity of energy consumption by the 5G System to provide services to a specific subscriber, e.g. in kilowatt hours [56].

Network Energy Information: NF Energy Information and/or AS Energy Information.

NF Energy Information: energy-related information collected from Network Functions and exposed by the EIF.

renewable energy: energy from renewable sources, defined as energy from renewable non-fossil sources, namely wind, solar, aerothermal, geothermal, hydrothermal and ocean energy, hydropower, biomass, landfill gas, sewage treatment plant gas and biogases [3].

UE Energy Information: energy-related information collected by the UE.

3.2 Symbols

Void.

3.3 Abbreviations

For the purposes of the present document, the abbreviations given in TR 21.905 [1] and the following apply. An abbreviation defined in the present document takes precedence over the definition of the same abbreviation, if any, in TR 21.905 [1].

5GC 5G Core

5GMS	5G Media Streaming
AC	Alternating Current
ADEME	Agence de l'Environnement et de la Maîtrise de l'Energie (the French ecological transition agency)
AF	Application Function
AMF	Access and Mobility Management Function
ANBR	Access Network Bitrate Recommendation
API	Application Programming Interface
Arcom	Autorité de régulation de la communication audiovisuelle et numérique (French Regulatory Authority for Audiovisual and Digital Communication)
AS	Application Server
ASP	Application Service Provider
ATSC	Advanced Television Systems Committee
CPE	Customer Premises Equipment
DSLAM	DSL Access Multiplexer
DSL	Digital Subscriber Line
DTT	Digital Terrestrial Television
DVB	Digital Video Broadcasting
DWDM	Dense Wavelength-Division Multiplexing
EEER	Equipment Energy Efficiency Ratio
EIF	Energy Information Function
ETSI	European telecommunications standards institute
GPON	Gigabit-capable Passive Optical Network
HD	High Definition
IBC	International Broadcasting Convention
ICT	Information and Communications Technology
ISP	Internet Service Provider
ITU-T	The Telecommunication Sector of the International Telecommunication Union
ITU-R	The Radiocommunication Sector of the International Telecommunication Union
KI	Key Issue
KPI	Key Performance Indicator
kWh	Kilowatt-hours
mAh	milliamp-hours
MBS	Multicast Broadcast System
MNO	Mobile Network Operator
MnS	Management Service
MPEG	Motion Picture Expert Group
MPLS	Multi-Protocol Label Switching
MSAN	Multi-Service Access Node
mWh/s	milliwatt-hours per second
NAB	National Association of Broadcasters
NEF	Network Exposure Function
NF	Network Function
NFV	Network Functions Virtualisation
NFVI	Network Functions Virtualisation Infrastructure
NG-RAN	Next Generation RAN
NPN	Non-Public Network
NSACF	Network Slice Admission Control Function
NWDAF	Network Data Analytics Function
OAM	Operations, Administration and Maintenance
OLT	Optical Line Termination
OTN	Optical Transport Network
PCF	Policy Control Function
PDU	Protocol Data Unit
PEE	Power, Energy, Environmental
PNF	Physical Network Function
QMC	QoE Measurement Collection
QoE	Quality of Experience
QoS	Quality of Service
RAN	Radio Access Network
SBMA	Service-Based Management Architecture
SDF	Service Data Flow
SDH	Synchronous Digital Hierarchy

SLA	Service Level Agreement
SMF	Session Management Function
SoC	System-on-Chip
SVoD	Subscription Video-on-Demand
TV	Television
UDM	Unified Data Management
UE	User Equipment
UPF	User Plane Function
VNF	Virtualized Network Function

4 Introduction to energy efficiency for media

4.1 General

4.1.1 Motivation

The reason for studying energy consumption in media delivery stems from a concern for the current state of the climate, and the need to mitigate the effects of human-induced climate change. These effects are due to greenhouse gas emissions associated with human activity, including the production of energy. In this regard, mitigation strategies revolve around 1) producing cleaner energy, and 2) using less energy. The latter is relevant for any sector, system or device not directly involved in producing energy, including those defined by 3GPP. However, with 70–80% of network traffic being media, media data centres, the transmission of media data and media consumption on UEs contribute significantly to the total energy consumed by mobile networks.

Considering the 5G System, energy efficiency of each of its components as well as the system as a whole is required. In order to achieve increased energy efficiency – both at the component level and at the system level – the system needs first to be characterised. Such characterisation additionally enables reporting, thereby informing the various stakeholders of the system's energy performance. High-level measurements illustrated in clauses 4.1.2 and 4.1.3 are too coarse to allow system performance improvements, nor does it allow individual stakeholders, including Application Service Providers, network operators, and end users to know their own instantaneous energy use. Having access to fine-grained information on energy use, for instance on streaming an individual content asset, would allow the identification of potential energy hot spots, and it would facilitate government-mandated reporting which is increasingly prevalent in certain markets.

This feasibility study therefore focuses on the possibility of putting infrastructure in place that would enable the measurement and reporting of energy consumption across the media delivery eco-system of 5G networks.

4.1.2 Energy and power in mobile networks

The terms power and energy are closely related, with power P being the rate at which work is done. It is measured in Watts or equivalently Joules per second (symbol W), or in derived quantities such as kW , MW or TW . Energy E is power integrated over time, measured in Joules (J), or equivalently Watt-seconds (Ws). Larger quantities are often measured in kilo-Watt-hours kWh , mega-Watt-hours MWh or tera-Watt-hours (TWh). One kWh represents $3.6 \times 10^6 J$.

For the year 2020, the global annual electricity consumption (AEC) of mobile networks (including 2G up to 5G, as well as satellite communication) is estimated to have been $161 TWh$, of which $146 TWh$ is spent by access networks, $6 TWh$ by the core network, and $9 TWh$ by support activities [8]. This represents $20 kWh$ per subscription per year [8]. In the period 2015–2018 this figure was estimated at $17 kWh$ per subscription per year [6].

To characterize the energy used to transmit data in a more fine-grained manner, energy-per-data figures are often reported, for example in kWh/GB . This suggests that a given network expends energy directly proportional to the amount of data communicated. This, however, has been shown to be an inaccurate measure due to the presence of significant fixed overheads. As an example, the servers in a data centre need to be cooled, irrespective of whether data passes through them or not. In addition, server and network switching hardware often has a fixed static base load energy consumption just for keeping it powered up.

For this, and other reasons, the transmission of data incurs a base load which is related to the presence and maintenance of the infrastructure itself, plus a mark-up that depends on the amount of data being transmitted.

Examples of power usage for 4G systems and use cases, taking into account such base load, are given in table 4.1.2-1 based on a paper published in 2020 [7]. The figures tabulated represent one user out of an assumed 300 connected to a single base station that is capable of accommodating a maximum of 1000 users.

Table 4.1.2-1: Example of power usage in 4G mobile transmission systems (after [7])

System / Use case	Bit rate (Mb/s)	a (W)	b (W/Mb/s)	P (W)
4G RAN		0.5 – 2	1 – 2	
4G data transmission and IP core network		0.05 – 0.5	0.03	
No data (inactive)	0	1.2	1.53	1.2
"YouTube" application service	1.5	1.2	1.53	3.4
"Netflix" application service	4	1.2	1.53	7.3
File download	40	1.2	1.53	62

Where for a bit rate (in megabits per second, Mb/s), a is the base load (in W), b is the data-dependent term (in $W/Mb/s$), and P is the power consumed (in W).

Based on the methodology of [7], as can be seen in table 4.1.2-1, the fixed overhead a is relatively important at low bit rates. For larger bit rates (e.g. the file download example) the transmission rate dominates the power consumption.

NOTE 1: In [7], base load is distributed evenly between the users so would, for example, be attributed to one user in the case where only one user is being served from a base station. This is not a widely accepted approach to energy consumption attribution.

NOTE 2: Although this marginal power relationship method is closer to reality than simplified linear energy attribution for data throughput, table 4.1.2-1 is purely a demonstration of one methodology based on limited data and evidence. More work needs to be done to confirm these relationships and to improve the accuracy of these power measurements due to inherent uncertainties involved in the cited example and diversity of infrastructure across the world [73].

4.1.3 Energy and power consumption for media services

According to [8] the global annual electricity consumption of smartphones and feature phones in 2020 is estimated to have been around 17 and 2 TWh respectively.

According to the French ecological transition agency, ADEME [83], "5.6 metric tons of carbon dioxide ($MtCO_2e$) emitted by the consumption of audiovisual content in France in 2022 which corresponds to linear TV, audio and video streaming on demand." ADEME adds that digital technology generates 3.5% of global greenhouse gas emissions [...] and predicts that, given the rapid growth of uses in this field, this "carbon footprint" will have increased by 29% by 2030 if we follow the current trend (less live TV, but more video on demand and video streaming).

4.1.4 Greenhouse gas emissions reporting and energy measurement

A study from Ember Climate [13] emphasises that electricity use may be mapped onto greenhouse gas via a conversion factor known as the *carbon intensity* measured in grams of CO_2 equivalent per kilowatt hour ($g\ CO_2-e/kWh$). The carbon intensity depends strongly on the method used to produce electricity and the energy source (e.g., coal, wind, solar, etc.), and therefore varies extensively across geographic locations. Currently, the carbon intensity ranges from under 100 CO_2-e/kWh to over 700 CO_2-e/kWh , with a global average of 436 CO_2-e/kWh (data from [13]).

The measurement of greenhouse gas emissions is difficult if not impossible to perform directly based on energy sources alone, but through the locally and globally known carbon intensities, energy consumption measurements may be converted to estimates of greenhouse gas emissions. The energy consumption of a 5G network and its components could therefore be used in combination with the carbon intensity of its location-specific energy grid to estimate greenhouse gas emissions. In the case where components of mobile networks are operated via on-site electricity generators (e.g., due to grid blackouts and/or lack of electricity infrastructure) granular information about energy sources becomes critical for accurate emission accounting.

4.1.5 Legislative frameworks for greenhouse gas reporting

Larger companies in European member states are subject to corporate sustainability reporting under the Corporate Sustainability Reporting Directive (CSRD), and following European Sustainability Reporting Standards which are

available under [12] supplementing Directive 2013/34/EU of the European Parliament and of the Council as regards sustainability reporting standards. This reporting law follows the Scopes defined by the Greenhouse Gas Protocol [10] (see clause 4.2.5).

Even though the Greenhouse Gas Protocol has been widely adopted by many countries, other regions in the world may be subject to local and/or additional reporting requirements.

4.2 Related work

4.2.1 Introduction

There have been significant efforts to better understand and estimate the environmental impacts of media consumption. There is evidence of early attempts to measure energy for media consumption in the UK, USA, EU and globally over the past decade [74, 75, 76, 77, 78].

Several standards setting organisations broadly active in the areas of broadcasting and telecommunications are currently considering energy efficiency and the reduction of climate impact. Likewise, several industry fora are active in this area. This clause documents some of the efforts underway, and references standards and reports currently available.

4.2.2 3GPP

4.2.2.1 Introduction

3GPP has undertaken significant efforts to address energy efficiency within mobile networks. Technical reports and specifications that outline methodologies for measuring and reporting energy consumption and efficiency have been developed. This includes the establishment of collection, reporting and exposure procedures at various components of mobile networks, which helps in assessing and optimizing the performance of network elements and services in terms of their energy usage.

4.2.2.2 Collection and exposure of energy consumption information at OAM

4.2.2.1.1 Introduction

This clause summarizes TS 28.554 [15] as it relates to the evaluation and collection of energy consumption information by the Operations, Administration and Maintenance (OAM) capability of the 5G System, as specified in 3GPP Release 18 by SA WG5.

4.2.2.1.2 Collection of network energy information by OAM

Clause 6.7.3 of TS 28.554 [15] defines the Energy Consumption KPI of a Physical Node. The network energy information that can be collected by the OAM capability includes that listed in table 4.2.2.1.2-1.

Table 4.2.2.1.2-1: Network energy information collected by OAM

KPI category	Description	Reference	Clause
Energy Consumption (EC) information	Energy Consumption of a gNodeB	TS 28.554 [15]	6.7.3.4.2
	Energy Consumption of the NG-RAN		6.7.3.4.1
	Energy Consumption of the 5GC		6.7.3.2.1
	Energy Consumption of a 5G Network Function		6.7.3.1.1
	Estimated Energy Consumption of a Virtualized Network Function		6.7.3.1.2
	Energy Consumption of a network slice	6.7.3.3	
	Energy Consumption of a Physical Network Function (PNF) as well as other Power, Energy, Environmental (PEE) measurements	TS 28.552 [16]	5.1.1.19.2
Energy Efficiency KPIs	Energy Efficiency of the NG-RAN data	TS 28.554 [15]	6.7.1
	Energy Efficiency of the 5GC		6.7.4.1
	Energy Efficiency of a network slice		6.7.2

In the case of a Virtualized Network Function (VNF) hosted on a physical node, the energy consumption of the VNF is estimated as a portion of the total energy consumption of the physical node on which the VNF is executing, based on its relative virtual CPU usage, virtual memory usage, virtual disk usage and I/O traffic (all metrics collected from ETSI MANO) as defined in clause 6.3.1.2 of TS 28.554 [15].

4.2.2.1.3 Exposure of network energy information by OAM

Network energy information may be collected by OAM and exposed (other mechanisms may exist) as defined by the Service-Based Management Architecture (SBMA) in TS 28.533 [17]. Any authorised consumer willing to collect such measurements or KPIs is first required by [17] to create an instance of a *performance metrics production job* (i.e., an instance of the *PerfMetricJob* information element – see clause 4.3.31 of TS 28.622 [18]) by invoking the *createMOI* operation of the Provisioning Management Service (MnS) (see clause 11.1.1.1 of TS 28.532 [19]).

The consumer is required by [17] to specify:

- Which measurement(s) or KPI(s) it wishes to be collected, e.g. the energy consumption of a 5G NF, etc.
- Which network entities (represented by *managed objects*) it wishes the information to be collected from (e.g., SMF x, UPF y, etc.).
- The granularity period (expressed in seconds) it wishes the measurements or KPIs to be reported over.
- The reporting method, mainly:
 - *File-based reporting*: Performance data is accumulated for a certain time before it is reported; the data is delivered as a file; the file content encoding is either XML or ASN.1.
 - *Stream-based reporting*: The producer sends the performance data to the consumer as when they are ready. The volume of the performance data reported is expected to be small, and the granularity period is expected to be short. The stream content encoding technique is either GPB or ASN.1.

Depending on the selected reporting method, the consumer collects the measurements or KPIs as follows:

- In the case of file-based reporting, the producer sends the notification *NotifyFileReady* to subscribed consumer(s) when a new file becomes available on the producer for subsequent download by consumer(s).
- In the case of stream-based reporting, the producer sends units of streaming data to the consumer by invoking the *reportStreamData* operation.

4.2.2.3 Collection and exposure of energy consumption information at NF

TR 23.700-66 [20] studies and identifies potential enhancements to the 5G System (e.g., including network energy-related information exposure, enhancement for subscription and policy control to enable energy efficiency as a service criterion) to improve energy efficiency and to support energy saving in the network.

Three different key issues have been identified in that study:

- KI#1: Network energy related information exposure
- KI#2: Subscription and policy control to support energy efficiency and energy saving as service criteria
- KI#3: 5GS enhancements for network energy saving and efficiency

KI#2 is not in scope of this study. The conclusions of KI#1 and KI#3 in clause 8 of TR 23.700-66 [20] and the normative work following will be used for collection and exposure of Energy Consumption information at Network Functions (NFs) and are summarised as follows:

1. A new network functionality will be defined to collect and calculate energy-related information and expose it to authorised consumers subject to the network operator's policy:
 - If the authorised consumer is a 5GC Network Function, the information exposure granularities that can be configured in this policy will include per application, per UE, per-UE-per-QoS Flow, per PDU session.
 - If the authorised consumer is an Application Function, the information exposure granularities that can be configured in this policy will include: per UE, per UE per application, per PDU session.

2. The energy-related information that can be exposed according to the above exposure granularities will include:
 - Energy Consumption information as defined in TS 28.310 [2].
 - Renewable energy information defined as energy from renewable non-fossil sources. For example (but not limited to) wind, solar, aerothermal, geothermal, hydrothermal.
3. A consumer of energy-related information (i.e., 5GC NF or AF) may request different modes of exposure (e.g. periodic reporting or threshold-based reporting) as part of its subscription request.
4. The new network functionality supporting the calculation of the Energy Consumption information includes the following aspects:
 - a) OAM: provides the NF/Node-level Energy Consumption information at the gNodeB(s) and UPF(s) serving the UE.
 - b) OAM: provides the overall data volume of the gNodeB.
 - c) The information of a) and b) received from OAM could be used by the new network functionality for all the UEs served by the NF/Node.
 - d) UPF: provides the data volume for the QoS Flow or the Service Data Flow (SDF).
 - e) When the gNodeB and/or the (I-)UPF(s) which are serving the UE change, the serving gNodeB ID and UPF ID will be sent to the new network functionality through AMF/SMF.
5. The new network functionality determines the end-to-end energy consumption based on energy consumption per the granularities above at the serving Network Function (i.e. NG-RAN and UPF).
6. In Release 19, only the energy-related information of user plane communication (not control plane signalling) is supported.
7. Enhancements to NF discovery and (re-)selection procedures based on energy-related information:
 - The NF profile may be extended (e.g. by including the new energy-related information or by reusing existing NF profile parameters) to allow an operator to influence NF discovery and selection based on its energy strategy.
 - NF discovery and (re-) selection will be enhanced to consider the energy-related information from the NF profiles and/or discovery requests from the NF consumer.
8. Enhancements to existing operations and procedures for energy saving and energy efficiency:
 - The User Plane path of a PDU session may be adjusted so that it consumes less energy.

The recommendations of the present document focusing on media services will need to be aligned with the conclusions in clause 8 of TR 23.700-66 [20] impacting Application Functions used for media services.

As specified in clauses 5.51 and 6.2.34 of TS 23.501 [72], the new network functionality referred to in point 1 above is called the *Energy Information Function* (EIF) and has the following responsibilities:

- Collect data from OAM and 5GC Network Function(s) to assist in the calculation of energy-related information.
- Calculate the energy-related information (including energy consumption information and renewable energy information) of user plane communication.
- Expose the calculated energy-related information to authorised consumers.
- Expose the energy-related information to authorized northbound consumers via the NEF.

4.2.2.4 UE data collection, reporting and event exposure

4.2.2.4.1 UE data collection, reporting and event exposure architecture

A generic architecture for the collection and reporting of UE data is defined in TS 26.531 [21] and the corresponding APIs are specified in TS 26.532 [22] but UE energy consumption has not been considered in these specifications up to

and including in Release 18. Subject to study in the present document, a potential solution would be to expand the scope of these specifications to support the collection and exposure of energy consumption information at UE.

The main principle of the reference architecture defined in clause 4 of TS 26.531 [21] and reproduced in figure 4.2.2.4-1 below is the addition of an intermediary Application Function named the Data Collection AF which is used collected UE data reports from data collection clients and Application Servers, and to synthesise from those reports a set of events which are exposed to event consumer subscriber, such as the Network Data Analytics Function (NWDAF) or an Event Consumer AF deployed in the Application Service Provider.

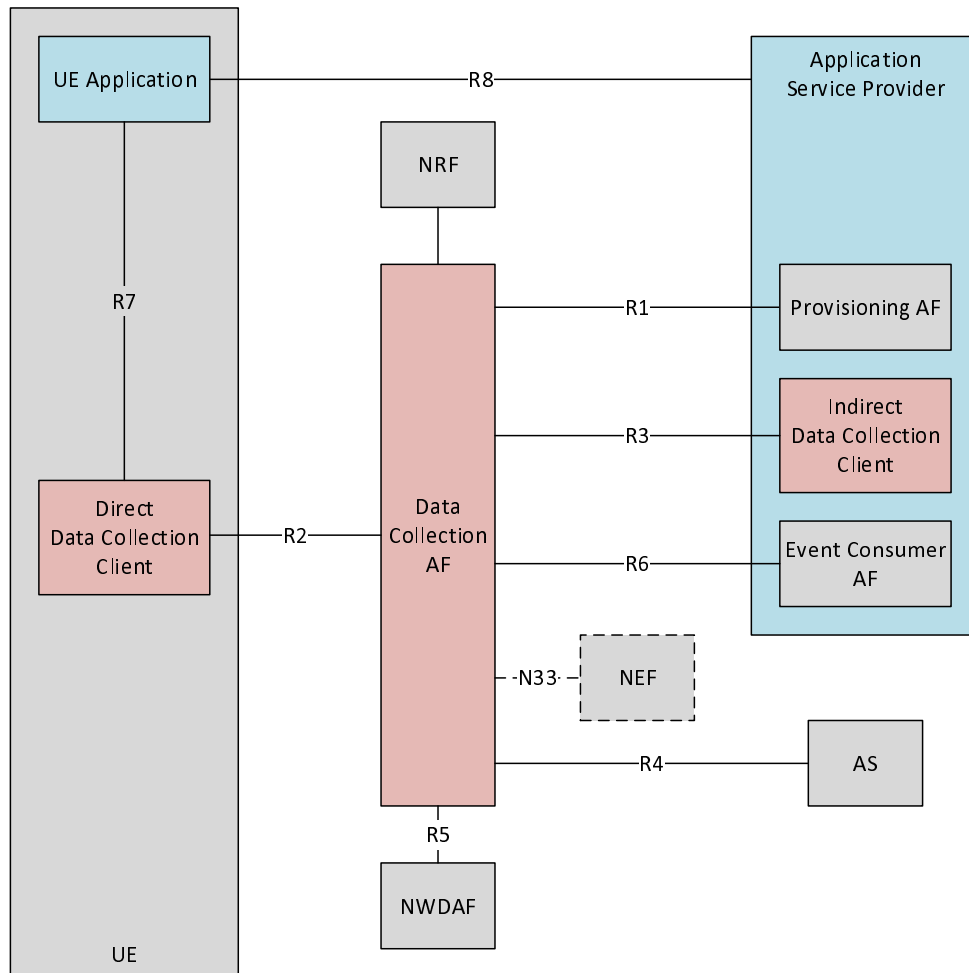

Figure 4.2.2.4.1-1: Reference architecture for data collection and reporting

Data collection and reporting functionality in the Data Collection AF is provisioned at reference point R1 by a *Provisioning AF* of the *Application Service Provider* that may be deployed either inside or outside the trusted domain. The purpose of the Data Collection AF is to receive UE data reports from one of three possible sources:

1. Directly from the UE. In this case the *Direct Data Collection Client* is responsible for collecting relevant data in the UE (typically from a UE Application using a suitable API at reference point R7) and for sending data reports to the Data Collection AF via reference point R2.
2. Indirectly from the UE. In this case, an Application Service Provider collects data from UE Applications privately via reference point R8 and employ an *Indirect Data Collection Client* subfunction to then send data reports to the Data Collection AF via reference point R3.
3. From an Application Server that has been used to deliver media to/from a UE. Application Server instances (AS) inside or outside the trusted domain may also collect data and report it to the Data Collection AF via reference point R4.

The Data Collection AF aggregates and filters UE data that is reported to it. The processed UE data is exposed by the Data Collection AF to the NWDAF in the form of data reporting event notifications via reference point R5. Certain UE

data may also be exposed in the form of data reporting events by the Data Collection AF to an Event Consumer AF residing in the Application Service Provider via reference point R6.

When they are deployed in different trust domains, the interactions between the system actors of the UE data collection, reporting and event exposure architecture may be mediated through the NEF, as illustrated by various collaboration scenarios defined in annex A of TS 26.531 [21].

4.2.2.4.2 UE data collection, reporting and event exposure for 5G Media Streaming

The instantiation of the UE data collection, reporting and event exposure architecture in the 5GMS System is defined in clause 4.7 of TS 26.501 [23] and the reference architecture for this instantiation is reproduced in figure 4.2.2.4-2.

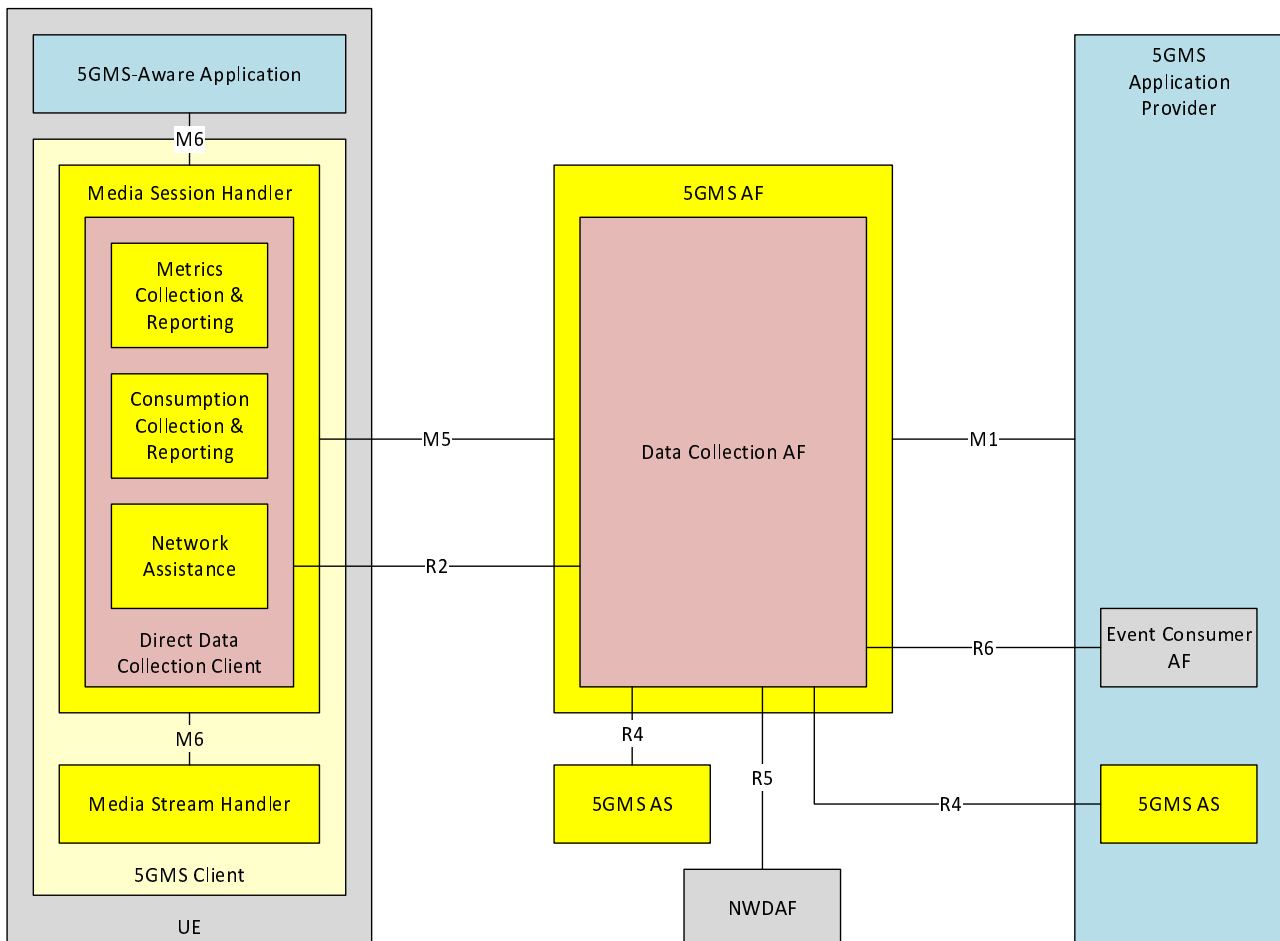

Figure 4.2.2.4-1: Data collection and reporting architecture instantiation for 5G Media Streaming

Three existing 5GMS reference points are reused in this instantiation: M1 (for provisioning UE data collection, reporting and event exposure), M5 (for media session handling) and M6 (for interacting with the Media Session Handler).

- The *Provisioning AF* of the Application Service Provider is not instantiated in the 5GMS architecture. Data collection and reporting is instead provisioned using the procedures using M1 defined in TS 26.501 [23].
- The *Data Collection AF* for 5G Media Streaming is instantiated in the 5GMS AF.
- The *Direct Data Collection Client* for 5G Media Streaming is instantiated in the Media Session Handler. This takes logical responsibility for the UE data collection activities of the *Metrics Collection & Reporting* and *Consumption Collection & Reporting* subfunctions and the subsequent reporting of this UE data via reference point M5. It also takes logical responsibility for the logging of ANBR-based Network Assistance invocations by the *Network Assistance* subfunction and their subsequent reporting to the Data Collection AF instantiated in the 5GMS AF via reference point R2.

NOTE: The use of M5 instead of R2 is due to the definition of some procedures before the definition of this instantiation. M5 was already used for QoE metrics and consumption reports, or invocations of the downlink dynamic policy procedures and invocations of the *AF-based downlink Network Assistance* procedures. Thus, for these procedures, M5 is used instead of R2.

- The Indirect Data Collection Client is not instantiated in the 5GMS architecture. Indirect reporting of UE data is outside the scope of 5G Media Streaming. Thus, R8 is not instantiated in the 5GMS architecture.
- The role of the AS in the abstract reference architecture is played by 5GMS AS. (This may be deployed as a trusted AS within the 5G System or deployed externally.)
- The Event Consumer AF is instantiated in the 5GMS Application Provider as a consumer of 5G Media Streaming events from the Data Collection AF.
- Reference point R7 is not instantiated in the 5GMS architecture. Configuration of 5GMS-related data reporting in the Media Session Handler by the 5GMS-Aware Application is managed through the existing media session handling client API at reference point M6.

4.2.2.5 QoE Measurement Collection (QMC) functionality

TS 38.300 [25] defines the QoE Measurement Collection (QMC) feature which enables collection of application layer measurements from the UE. QMC is supported for the following service types in NR cells:

- QoE Measurement Collection for DASH streaming services in TS 26.247 [24];
- QoE Measurement Collection for MTSI services in TS 26.114 [26];
- QoE Measurement Collection for VR services in TS 26.118 [27].

The QMC feature also supports collection of QoE measurements for any of the supported service types carried by the MBS communication service defined in TS 23.247 [64], namely:

- MBS broadcast;
- MBS multicast.

More details of QMC control and configuration can be found in TS 28.405 [28]. A potential solution would be to reuse and expand the QMC functionality to support the reporting of energy consumption information by the UE.

4.2.3 Other Standards Development Organisations

4.2.3.1 ITU-T

Within the International Telecommunication Union, the T-sector includes Study Group 5 "Environment and Circular Economy" (SG5). Part of its mandate is to define and develop "methodologies for evaluating ICT effects on climate change and publishing guidelines for using ICTs in an eco-friendly way. Under its environmental mandate SG5 is also responsible for studying design methodologies to reduce ICT's and e-waste's adverse environmental effects, for example, through recycling of ICT facilities and equipment."

Among its activities, ITU-T Study Group 5 is developing technical reports, supplements and recommendations for the environmental requirements of 5G.

- Recommendation ITU-T L.1310 [29] contains the definition of energy efficiency metrics, test procedures, methodologies and measurement profiles required to assess the energy efficiency of telecommunication equipment. Energy efficiency metrics and measurement methods are defined for telecommunication network equipment and small networking equipment. These metrics allow for the comparison of equipment within the same class, e.g., equipment using the same technologies.
- ITU-T L.1310 Supplement 36 [30] analyses the energy efficiency issues for 5G systems. The focus of this supplement is on methods and metrics used to measure energy efficiency in 5G systems with multi-radio equipment.

Further, the L.1400 series of reports and recommendations present methodologies and guidelines for the assessment of the greenhouse gas emissions and energy consumption of the ICT sector. For example:

- Recommendation ITU-T L.1450 [31] presents a methodology for the assessment of the impact of telecommunications systems. It was used in an assessment of the electricity usage and greenhouse gas emissions of the ICT sector [32].

4.2.3.2 ITU-R

The remit of ITU-R Study Group 6 (SG6) is programme production and interchange. Its Working Party 6A (WP 6A) has published ITU-R Report BT.2385 "Reducing the environmental impact of terrestrial broadcasting systems" [33]. Working Party 6C (WP 6C) has a rapporteur group which has produced the following documents:

- ITU-R Opinion 104, "Advice for sustainability strategies incorporating carbon offsetting policies" [34]
- ITU-R Report BT.2521, "Practical examples of actions to realize energy aware broadcasting" [35]. This report is based on a webinar held in March 2022.
- ITU-R Report BT.2540, "Display energy reduction through image signal processing" [36]. This document describes techniques for producing, transmitting and using metadata which enables display devices to use less energy.

4.2.3.3 MPEG

The ISO/IEC JTC 1/SC 29 committee *Coding of audio, picture, multimedia and hypermedia information* has published the ISO/IEC 23001-11:2023 (Green MPEG) standard [37]. The various components of the standard define methods for the reduction of the power consumption of decoders and of displays. A further component defines a method for the selection of energy-efficient media. A final method allows for quality recovery after low-power encoding. The standard is currently in revision, and it is to be extended to enable the carriage of metadata to more efficiently reduce the power requirements of display devices receiving the content with the metadata.

4.2.3.4 DVB

DVB has carried out a study mission to assess the potential for developing energy-efficient video transmission systems. This work has resulted in the creation of a new CM-EE (Energy Efficiency) working group in its Commercial Module. It has also published a report on the topic available as Blue Book S100 "Study Mission report on Energy Aware service Delivery and Consumption" [38].

4.2.3.5 ATSC

ATSC's "Planning Team 9 – Sustainability in Media and Data Delivery Services (PT9) will study the benefits of broadcast data delivery as relates to sustainable energy usage in a world increasingly dependent on data delivery. The team will consider linear and file-based media delivery as well as linear and file-based data delivery. PT9 will report the results of this work to the Board. If technical work in ATSC is recommended, PT9 will further document rationale for the work and ideally also document possible architectural approaches and requirements, such as interoperability with existing networks, which would accommodate the identified use cases. PT9 does not draft standards or recommended practices; it may draft New Project Proposals and/or Planning Team Reports. PT9 reports to the ATSC Board of Directors and participation is open to all ATSC members." [39].

4.2.3.6 ETSI

4.2.3.6.1 Summary of energy efficiency standards drafted by the ETSI Environmental Engineering (EE) Working Group

Table 4.2.3.6.1-1 below shows a summary of energy efficiency standards developed by the ETSI Working Group on Environmental Engineering (EE). The list is non-exhaustive.

Table 4.2.3.6.1-1: List of ETSI Environmental Engineering (EE) specifications

Standard	Summary
ETSI ES 202 706-1 [4]	Defines the measurement method for the evaluation of base station power consumption and energy consumption with static load. The methodology described in this specification is to measure base station static power consumption and RF output power. Within the document it is referred to as "static" measurements. The results based on "static" measurements provide power and energy consumption figures for a Base Station under static load.
ETSI ES 203 700 [41]	Defines power feeding solutions for 5G, converged wireless and wireline access equipment and network, taking into consideration their enhanced requirements on service availability and reliability, the new deployment scenarios, together with the environmental impact of the proposed solutions. The minimum requirements of different solutions including power feeding structures, components, backup, safety requirements, environmental conditions are also defined.
ETSI ES 203 539 [42]	Defines energy efficiency metrics and measurement methods for NFV components including VNFs and NFVI. The energy efficiency of VNF is evaluated according to hardware energy consumption, resource consumption and utilization related with VNF. The energy efficiency of NFVI is evaluated as resource provision capability which is expressed as service capacity of reference VNFs running on it with amount of energy consumption.
ETSI EN 303 470 [43]	Specifies a metric for the assessment of energy efficiency of computer servers. Formalizes the tools, conditions and calculations used to generate a single figure of merit of a single computer server representing its relative efficiency and power impact. The metric is targeted for use as a tool in the selection process of servers to be provisioned.
ETSI EN 303 471 [44]	Specifies the method and metrics to determine the energy efficiency of operational Network Function Virtualisation (NFV) applications and their associated infrastructure. It specifies the method and metrics to determine the energy efficiency of operational Network Function Virtualisation (NFV) applications and their associated infrastructure when that infrastructure is implemented outside the boundaries of the access fixed, cable and mobile networks which they serve.
ETSI ES 203 475 [45]	Specifies terminology, principles and concepts for Energy efficiency and energy management. It aims to establish a common understanding of measurement methodology used to determine the energy efficiency of a good, service and network. It presents a framework for other ETSI standards and other Standard Development Organization documents about Energy Efficiency.
ETSI ES 203 136 [46]	Defines the energy consumption metrics and measurement methods for packet routing and Ethernet switching equipment. It defines the methodology and the test conditions to measure the power consumption of a router or switch. It is applicable to core, edge and access routers. Home gateways are out of scope.
ETSI EN 303 215 [47]	Defines power consumption metrics, methodology and test conditions to measure the power consumption of broadband fixed telecommunication network equipment. It does not cover all possible configuration of equipment, but only homogenous configurations. The types of broadband access technologies covered are: DSLAM DSL, MSAN, GPON OLT and point-to-point OLT equipment.
ETSI ES 202 706 [4]	Defines methods for evaluation of power consumption and energy efficiency of base station in static and dynamic mode. The methodology described is to measure base station static power consumption and dynamic energy efficiency, which are referred to as static and dynamic measurements respectively. The results based on "static" measurements of the Base Station power consumption provide a power consumption figure for the Base Station under static load. The results based on "dynamic" measurements of the Base Station provide energy efficiency information for a Base Station with dynamic load.

ETSI ES 203 184[48]	Defines the metric, methodology and the test conditions to evaluate the Equipment Energy Efficiency Ratio (EEER) of Transport equipment, including all the transmission equipment connected to the network by means of wired medium (i.e. copper or fibre), typically running at the network OSI Layer 1. The present document also covers the equipment running at the network OSI Layer 2 (e.g. MPLS-TP) that are not included in the ETSI standard on "Measurement Methods for Energy Efficiency of Router and Switch Equipment" (the same approach is followed by ATIS standard on Transport equipment. Examples of typical wired Transport equipment covered by the present document are switches or crosses connects (SDH, OTN) and add/drop multiplexers (DWDM). The present document covers also simpler systems as multiplexers/demultiplexers (DWDM), optical amplifiers, transponders.
ETSI EN 301 575 [49]	Defines energy consumption measurement methods for Broadband CPE telecommunication equipment. Also defines a methodology and test conditions to measure the power consumption of end-user broadband equipment.
ETSI ES 203 215 [50]	Defines energy consumption limits and measurement methods for fixed broadband telecommunication network equipment. Also defines power consumption limits, a methodology and test conditions to measure the power consumption of broadband fixed telecommunication networks equipment. The types of broadband access technologies covered are: DSLAM DSL, MSAN, GPON OLT, Point to Point OLT equipment.

4.2.3.6.2 Definition of Mobile Network Energy Efficiency

ITU-T L.1310 [29] defines energy efficiency as the relationship between the specific functional unit for a piece of equipment (i.e., the useful work of telecommunications) and the energy consumption of that equipment. For example, when transmission time and frequency bandwidth are fixed, a telecommunication system that can transport more data (in bits) with less energy (in Joules) is considered to be more energy-efficient. For this reason, metrics that can evaluate the performance of a piece of equipment against its energy consumption are to be defined.

From Release 15 onwards, the definition of Energy Efficiency is clarified in 3GPP. The definition does not come directly from 3GPP itself, but rather is adopted from the ETSI Working Group on Environmental Engineering, in ETSI ES 203 228 [66] which aims to define the topology and level of analysis to assess the energy efficiency of mobile networks. In particular, [66] defines metrics for mobile network energy efficiency and methods for assessing (and measuring) energy efficiency in operational networks.

Per ETSI ES 203 228 [66], Energy Efficiency (EE) of a Mobile Network is defined as the relation between the useful output and power consumption, where power consumption is defined as the power consumed by a device to achieve an intended application performance.

Mobile Network data Energy Efficiency EE_{NE} is the ratio between the performance indicator Data Volume (DV_{MN}) and the Energy Consumption (EC_{MN}) when assessed during the same time frame (T) as defined in clause 7.1 of ITU-T recommendation L.1331 [67]. This is also shown by the formula:

$$EE_{NE} = \frac{DV_{MN}}{EC_{MN}}$$

where DV is the Data Volume, expressed in bits, transported across a network element. The Data Volume measurements are collected via OAM. EC is the Energy Consumption, expressed in Joules, of the same network element. The MN suffix stands for Mobile Network.

NOTE: This relationship assumes a simplified linear relationship between data transfer and energy consumption. New evidence suggests a marginal relationship between throughput and energy [79, 80, 81]. It would be useful to consider how new understanding influences this energy efficiency measurement equation.

This formula is reproduced in several 3GPP Technical Specifications and Technical Reports dealing with energy efficiency (EE).

Clause 8.2 of ITU-T L.1331 [67] illustrates how to measure/collect the information about data volume (for capacity), coverage area (for coverage) as well as energy consumption over a measurement period called T , spanning one week, one month, or longer periods.

In addition, annex T of TS 23.501 [72] provides examples of how the Energy Information Function (EIF) described in clause 4.2.2.3 calculates the energy consumption for the required granularities.

4.2.4 Industry fora

4.2.4.1 Greening of Streaming

Greening of Streaming is a member association investigating energy efficiency in the context of media streaming applications [51]. One of the challenges the group is aiming to address is that of accurately measuring the energy expenditure of streaming services, given that currently the available data is sparse and not very precise. It further intends to define best practices.

4.2.4.2 DIMPACT

"DIMPACT is a collaborative initiative between leading media, entertainment and technology companies and world-class researchers" [52]. The group is convened by Carnstone Partners Ltd, and research and technical expertise is provided by researchers from the University of Bristol. It has currently over 20 members. The group has developed a tool to measure the emissions of serving digital media and entertainment products. This tool is available as a web application and is able to estimate emissions originating from video streaming, online banner advertising, digital publishing, and audio streaming. The DIMPACT website makes available several publications explaining their methodology [53] and defining principles for streaming and digital media carbon footprinting [54].

4.2.4.3 Ultra HD Forum

The Sustainability Working Group of the Ultra HD Forum is investigating energy efficiency opportunities throughout content distribution, from content encoding through distribution and display. One result has been a regular series of public demonstrations directed to sustainability at major broadcast conferences (specifically IBC and NAB) where the Ultra HD Forum regularly has a booth [55]. Some of these demonstrate the degree of influence the consumer can have on the energy consumption by the display.

4.2.5 Greenhouse Gas Protocol

The Greenhouse Gas Protocol [9] is a joint initiative of the World Resources Institute and the World Business Council for Sustainable Development (WBCSD) that "provides standards, guidance, tools and training for business and government to measure and manage climate-warming emissions." The first edition of their reporting standard was published in 2001, establishing a reporting framework for businesses. Relative to a given company, the concept of "scopes" is introduced, which delineate direct and indirect emission source, and are used for accounting and reporting purposes. The reporting principally involves the six greenhouse gasses that are defined in the Kyoto protocol: carbon dioxide (CO_2), methane (CH_4), nitrous oxide (N_2O), hydrofluorocarbons (HFCs), perfluorocarbons (PFCs) and sulphurhexafluoride (SF_6). Scopes 1 (sources owned or controlled by a company giving rise to direct greenhouse gas) and 2 (the electricity purchased and consumed by a company gives rise to greenhouse gas emissions) are defined in [10], and Scope 3 (All other indirect emissions) is defined in [11].

NOTE: 3GPP SA5 is also considering the Greenhouse Gas Protocol as part of TR 28.913 [14].

4.2.5.1 Scope 1

Sources owned or controlled by a company give rise to direct greenhouse gas emissions. The activities undertaken by a company that give rise to scope 1 emissions include the generation of electricity, heat, or steam; physical or chemical processing; transportation of materials, products, and waste; fugitive emissions.

4.2.5.2 Scope 2

The electricity purchased and consumed by a company gives rise to greenhouse gas emissions. Scope 2 emissions occur at the facility where the electricity is generated, rather than where the electricity is consumed. For the reporting company, these emissions are therefore counted as one form of indirect emissions. As purchased electricity is for many companies one of the largest sources of greenhouse gas emissions, it also offers a significant potential for reductions, either by investing in energy efficient technologies, by energy conservation, or by switching to less greenhouse gas intensive sources of electricity.

4.2.5.3 Scope 3

All other indirect emissions can be reported under scope 3. The emissions reported in this category are the consequence of the activities of a company, but they come from sources not owned or controlled by this company. These indirect emissions arise elsewhere in the corporate value chain of a given company, both upstream and downstream. Upstream emissions are indirect emissions relating to purchased or acquired goods and services. Downstream emissions relate to sold goods and services. Scope 3 indirect emissions are categorised into 15 distinct categories, of which the upstream categories are:

1. **Purchased goods and services.** Extraction, production, and transportation of goods and services purchased or acquired by the reporting company in the reporting year, not otherwise included in categories 2 to 8.
2. **Capital goods.** Extraction, production and transportation of capital goods, purchased or acquired by the reporting company in the reporting year.
3. **Fuel- and energy-related activities (not included in scope 1 or scope 2).** Extraction, production, and transportation of fuels and energy purchased or acquired by the reporting company in the reporting year.
4. **Upstream transportation and distribution.** Transportation and distribution of purchased products or services in the reporting year, including inbound and outbound logistics; transportation between a company's own facilities.
5. **Waste generated in operations.** Disposal and treatment of waste generated by the reporting company's operations in the reporting year.
6. **Business travel.** Transportation of employees for business-related activities in the reporting year in vehicles not owned or operated by the reporting company.
7. **Employee commuting.** Transportation of employees between their homes and their worksites during the reporting year, in vehicles not owned or operated by the reporting company.
8. **Upstream leased assets.** Operation of assets leased by the reporting company in the reporting year.

The downstream categories are:

1. **Downstream transportation and distribution.** Transportation and distribution of products sold by the reporting company in the reporting year between the reporting company's operations and the end consumer, if not paid for by the reporting company (in vehicles and facilities not owned by the reporting company).
2. **Processing of sold products.** Processing of intermediate products sold in the reporting year by the downstream companies.
3. **Use of sold products.** End use of goods and services sold by the reporting company in the reporting year.
4. **End-of-life treatment of sold products.** Waste disposal and treatment of products sold by the reporting company (in the reporting year) at the end of their life.
5. **Downstream leased assets.** Operation of assets owned by the reporting company and leased by other companies in the reporting year.
6. **Franchises.** Operation of franchise in the reporting year.
7. **Investments.** Operation of investments (including equity and debt investments and project finance) in the reporting year.

4.2.6 Report on carbon impact of video streaming

After significant debate over the environmental footprint of video streaming, a group of broadcasters and media companies working with the DIMPACT consortium (see clause 4.2.4.2) and the Carbon Trust published in 2021 a widely agreed estimate of hourly emissions associated with video streaming [80] that considers devices capable of streaming across both mobile and broadband networks. This work resulted from a previously established methodological framework developed by BBC Research & Development and the University of Bristol to measure broadcast and streaming energy.

The report considers consumption of video streaming services on different combinations of representative devices, including home routers, TV peripherals (e.g. Set Top Box) and end user terminal devices including TV, Laptops, Desktop, Tablets and Mobile phones. The overall video traffic is normalised for an hour of viewing at a representative end user device after normalising average time spent on different devices. There are some specific use cases that have been specifically demonstrated for their streaming energy. These include:

1. Smartphone (Apple iPhone) connected to mobile network.
2. Laptop computer connected to a home router via Wi-Fi.
3. 50" smart TV set connected to a home router via Wi-Fi.

The methodology normalises overall streaming across mobile and broadband networks and assigns energy consumption per unit data to each network, expressed in kWh/GByte. The methodology also averages the energy consumption in proportion to the viewing time on the different types of end user terminal device considered.

Table 4.2.6-1 summarises the average energy consumption per hour of video streaming across all end user terminal devices considered. For convenience, this figure is also converted to the equivalent grams of carbon dioxide that would be emitted based on a representative energy mix for Europe in 2020.

Table 4.2.6-1: Energy consumption and emissions associated with video streaming process components for Europe in 2020 [80]

Video streaming component stage	Streaming energy consumption (Wh/hour)	Streaming emissions (gCO ₂ e/hour)	Proportion of total
Data centres	1	< 1	1%
Transmission network	20	6	10%
Home router	71	21	38%
TV peripheral	10	3	5%
Screens	86	25	46%
Total	188	56	100%

Taking an average EU energy mix and a representative device considering the overall content distribution chain, the report estimated that an hour of video streaming consumes 188 Wh of energy or ~56 gCO₂e per hour of video streaming. In particular:

- Data centres (including hosting, encoding and CDNs) account for less than 1 gCO₂e/hour based on energy consumption of approximately 1 Wh/hour, representing roughly 1% of total energy and therefore emissions.
- Network transmission (core and access) accounts for 6 gCO₂e/hour and 20 Wh/hour (10% of total energy and therefore emissions).
- Home routers account for 21 gCO₂e/hour and 71 Wh/hour (38% of total energy and therefore emissions).
- End-user devices account for 28 gCO₂e/hour (25 gCO₂e/hour from viewing devices and 3 gCO₂e/hour from peripherals) based on energy consumption of 96 Wh/hour (86 Wh/hour from screens and 10 Wh/hour from peripherals).

Results confirmed that devices in the home – including home routers and TV peripherals as well as the end user terminal devices themselves – consume a significant proportion of total energy and account for almost 89% of emissions across the whole streaming value chain. Depending on the choice of user device, the emissions associated with an hour of video streaming can vary from 8 gCO₂e/hour for a smartphone to 16 gCO₂e/hour for a laptop computer or 58 gCO₂e/hour for a 50" smart TV set.

Several limitations of these findings are highlighted in [80], including lack of representative data, attribution of network energy over millions of consumers and the methodological assumptions to simplify the modelling.

4.2.7 Energy estimates for broadcast and streaming energy consumption in the UK

Ofcom, the UK communications regulator published in 2022 through Carnstone its own energy estimates for broadcast and streaming energy consumption in the UK [82] using the previously established methodological approach developed by BBC Research & Development referred to in clause 4.2.6. The estimates compare the energy footprint of an hour of viewing media on a representative user device across the entire distribution value chain. The analysis was initially carried out for the year 2019 and was later updated for 2021. Even though the scale of energy consumption was similar in magnitude to that of the EU (as described in clause 4.2.6), hourly energy consumption for video streaming was estimated to be lower at 113 Wh per hour of streaming. This was equivalent to ~33 gCO₂e/hour streaming on a representative viewing device for the UK.

Table 4.2.7-1: Energy and Emission footprint of an hour of video streaming in the UK

Video streaming component stage	Streaming energy consumption (Wh/hour)	Streaming emissions (gCO ₂ e/hour)	Proportion of total
Network transmission	12.0	3.5	10.8%
Customer Premises Equipment	21.5	6.2	18.6%
Peripherals	21.5	6.2	18.6%
Viewing devices	58.0	17.0	51.3%
Total	~113.0	33.0	~100.0%

Like previous studies, the Ofcom report [82] confirmed that a considerable proportion of the total energy consumption – approximately 89% – occurred within the home, concentrated around viewing devices and in-home networks.

Methodological and data-related concerns are similar to those described at the end of clause 4.2.6, necessitating further efforts for improved and robust measurements.

4.2.8 Study on predicted environmental impact of audiovisual media consumption in France

In 2022, the audiovisual communications regulator for France, Arcom, and its communication networks regulator, Arcep, published a joint study [61] on the predicted environmental impact of audiovisual media consumption in France over the period from 2022 to 2030. The study assesses the environmental impact of consuming audiovisual mass media, taking all the component parts into account: hardware (user devices), networks (fixed broadband and superfast broadband, digital terrestrial, and satellite) and data centres. Its scope includes the main systems used to access audiovisual media: linear and time-shifted television and radio, audio and video streaming (including video-on-demand services), and video sharing platforms. Every type of impact has been assessed (carbon footprint, consumption of mineral and metal resources, final energy consumption) including energy usage, the target for the framework of the report.

In this study, energy usage (termed *final energy consumption*) is measured in kilowatt-hours (kWh) and refers to the quantity of electricity consumed during the usage phase of the three tiers of the digital value chain (user devices, networks and data centres). It concerns itself only with the usage stage of terminals, networks, and data centres; upstream electricity consumption for the manufacturing phase is not addressed by this indicator.

A comparative assessment of nine audiovisual usage scenarios (on the scale of one hour of audio or video content consumption in France in 2022) is considered in the report:

- **A1:** Listening to live FM radio on a radio set
- **A2:** Listening to live FM radio on a car radio
- **A3:** Listening to live radio via the Internet on a smartphone connected to the fixed network
- **A4:** Listening to music/podcast on a streaming platform (app) on a smartphone connected to the Internet via mobile network
- **V1:** Watching a TV channel in HD on a television via integrated Digital Terrestrial Television (DTT) access

- **V2:** Watching a TV channel in HD on a television connected to the Internet via a TV decoder linked to an ISP box (managed IPTV)
- **V3:** Watching catch-up TV in HD on a smart TV connected to the Internet via a TV decoder linked to an ISP box
- **V4:** Watching Subscription Video-on-Demand (SVoD) in HD on a smart TV connected to the Internet via fixed network
- **V5:** Watching online videos on a video sharing platform in HD on a smartphone connected to the Internet via mobile network

To estimate energy consumption of devices, four different devices have been evaluated under laboratory test conditions (two smartphones, one PC and one smart TV set).

- For the smart TV and the PC, a measurement module (digital watt meter) is inserted between the device and the mains power outlet. This module measures energy consumption in Alternating Current (AC). The watt meter is connected to a computer to record the energy consumption measurements.
- For smartphones, measurements are taken using software probes to record energy and data consumption.

Energy is measured in units of milliwatt-hours per second (mWh/s) or milliamp-hours (mAh). The measurements are sampled for a period of one minute. Several iterations are performed (a minimum of three samples) to ensure relevance and to limit artifacts related to the measurement itself. Testing conditions are noted for traceability of the measurements.

Two measurement modes are possible:

- *Systematic content change between iterations.* This measurement mode has the advantage of eliminating the effects of content caching strategies in the terminal device or delivery network but has the disadvantage of introducing variability. However, this measurement mode is more representative of real-world user behaviour.
- *Iterations are conducted on a continuously played video.* This measurement mode has the advantage of controlling for the variability of content but has the disadvantage of potentially underestimating consumption due to caching technologies.

The systematic content change solution is favoured in the scenario V5 (video sharing platforms). On the other hand, the continuous video strategy is used when it is useful to control for the content's impact and to study certain parameters (such as video codec).

Given the diversity of hardware studied, it was decided that the user journey would not be automated.

The data measured under laboratory test conditions are very specific. They are conducted on a single device (two for smartphones), which performs a single precise usage. This allows, for example, consumption during content playback to be differentiated from browsing a content catalogue. However, these measurements are not necessarily representative of the entire equipment landscape. Thus, comprehensive and representative data from the literature on a more diverse equipment pool were preferred over certain laboratory measurements for the quantification of audio and video usage at the national level in France.

In the context of the present document:

- The method to estimate the energy consumption of the mobile network described in [61] is not reusable because it uses a theoretical calculation based on the total amount of energy consumed by the mobile network, the mobile network usage duration per subscriber and a formula allocating energy consumption per subscriber per year and per data volume.
- The method to estimate the energy consumption of data centres described in [61] is not reusable either because it is based on external estimates.
- The method to estimate the energy consumption of a UE described in [61] could be used as a basis for evaluating the energy usage/savings of multimedia standards features and proposals on UEs.

4.3 Challenges in accurately estimating energy consumption

Even though several regulators, academics and media organisations have examined and published energy estimates, significant challenges remain in accurate and robust estimates of energy consumption as noted in [73] and [79].

The primary challenge so far has been around *obtaining accurate power data at the hardware level* for mobile and fixed networks, and for end user devices. Understanding how the relationship between data and energy plays out with data throughput and peaks is another point of concern. Accurate energy consumption data by both server hardware and network components remains difficult to achieve in practice.

The other big challenge is the *attribution of energy for specific data throughput on the existing value chain* and the *allocation of this energy between stakeholders* benefitting from network connectivity. The issue here is that hardware elements service multiple users at the same time, and in addition the relationship between energy and data throughput is not linear due to an often significant base load incurred by having the equipment switched on in the first place. Legal and regulatory pressures to achieve net zero emissions make allocation a key business strategy requirement. Agreements between network operators and their consumers in this regard are contentious due to responsibilities and costs of achieving net zero. System boundaries for energy measurements are also quite important in this discussion and where to draw the line can often influence the onus for responsibility.

Further, while individual elements of a transmission system could in principle be measured and instrumented, for reporting applications it would be advantageous to be able to determine the energy used to deliver a given media item from source to sink, i.e. as the data passes through a variety of network elements.

The implications of these challenges are that only relatively coarse-grained assessments of energy use can currently be made. These assessments are typically seen as sufficient for policy making, but are insufficient for understanding the energy bottlenecks in existing systems, or for understanding how to design more efficient systems. Further, current practices are insufficient for reporting duties as standardised by the Greenhouse Gas Protocol, and as required by the European Union and the State of California (Scope 3 reporting – see clause 4.2.5). The collection of fine-grained energy consumption data in (near-)real time from media applications running on user devices and Application Servers would contribute towards solving these issues. The present document can help to define a futureproof measurement framework to assist in this aim.

5 Use cases

5.1 Baseline use cases defined by SA1

Use cases regarding enhancements to Energy Efficiency of 5G network and application service enabler aspects are listed in TR 22.882 [56]. Five of them have been identified as media-related and therefore fall within the scope of this study:

- *Use case 5.5 on service energy monitoring by an Application Server:* The Application Service Provider cares about energy consumption in the Data Network as a result of the service provided by an Application Server to UEs. This could be for one or more of the following three reasons:
 - The Application Service Provider needs to demonstrate that it is reducing energy consumption;
 - The service has an associated energy cost, and the Application Service Provider wants to reduce it;
 - The Application Service Provider recognises that there are policies that limit energy use and controls the overall use of the service to operate within those constraints.
- *Use case 5.6 on supporting service-level energy efficiency analysis for verticals:* An Application Service Provider is running three different enterprise applications over two network slices. It proposes exposure of data volume and energy consumption of different Network Functions participating in the delivery of the service for different time periods at the request of the Application Service Provider. The Application Service Provider may use existing 3GPP procedures to infer Network Slice energy consumption and the number of PDU sessions per network slice.
- *Use case 5.8 on Application service Energy Efficiency (AEE) monitoring:* The energy consumed by an application service at the device side as well as at the network side is monitored and predicted by the 5G System

and is exposed as a monitoring event to the Application Service Provider to allow an application layer action. In the context of media delivery, this action could be for example triggering multicast/broadcast delivery for a given service area and time of the day.

- *Use case 5.9 on renewable energy consumption information exposure:* Mobile Network Operators need to understand and track the proportion of energy consumed in their networks that is sourced from renewable sources, which can be made available to customers and authorized third parties.
- *Use case 5.10 on supporting carbon-aware communication service:* The Mobile Network Operator provides to end users an estimate of the carbon emissions for the services consumed, for example the equivalent carbon dioxide emissions corresponding to the data consumed by a user during a particular billing cycle.
- *Use case 5.14 on reducing GHG footprint of Application Services:* By considering the temporal and spatial information of sustainable energy source and availability, the possibility of reduction of the greenhouse gas footprint for application services is explored. Rather than optimising compute tasks for highest throughput or lowest latency, those tasks having flexibility in both when and where they are executed (e.g., some AI/ML training or video processing) are routed to a computing node using the (most) sustainable energy sources at that moment.

Media-related requirements associated with these use cases are addressed in the following Key Issues, complemented by requirements associated with the findings identified in clause 4.

5.2 Additional use cases defined by 3GPP SA WG4

Use cases defined by SA WG1 on energy monitoring or energy consumption information exposure are not yet taken into consideration in 26.XXX series specifications but similar use cases have already been addressed. As explained in clause 4.2.2.4, some mechanisms like UE data collection, reporting and event exposure have already been defined. For consistency between specifications, supporting the collection and exposure of UE energy consumption information will require expansion of these existing mechanisms or else the use of mechanisms widely deployed in the market. This expansion will have to take into consideration indicators requested by regulators.

In France, the "Chaize Act" on reinforcing regulation of the digital sector by Arcep (France's Regulatory Authority for Electronic Communications, Postal Affairs and Press Distribution), strengthens Arcep's powers by giving it the ability to collect environmental data not only from electronic communications operators, but also from online communication service providers, data centre operators, consumer device manufacturers, network equipment suppliers and operating system providers. Arcep has been collecting indicators since 2020 from France's four largest telecoms operators, to be able to track the evolution of their environmental footprint, and relays this information through the publication of its annual "Achieving digital sustainability" survey [57]. The fourth edition of the survey, which Arcep will be publishing in early 2025, will incorporate data for monitoring the environmental footprint of a new category of player, namely mobile network equipment suppliers. This work has been complemented by Arcom (the French Regulatory Authority for Audiovisual and Digital Communication) in its recommendation n° 2023-02 about consumer information on energy consumption and greenhouse gas emissions equivalents of data consumption related to the use of television services, on-demand audiovisual media services and video sharing platform services.

In addition to collecting energy consumption information from UEs and exposing it to event consumers, Arcom encourages collection and exposure of energy consumption information *to* UEs could help to address the energy efficiency issue. This would be used to inform users about the environmental impact of consuming audiovisual content, but this information could also be used by UEs to optimise energy efficiency associated with media consumption.

Arcom also encourages service providers to offer access to video quality parameter settings, allowing an easy way for end users to choose a simple "energy efficiency" mode. Instead of always being in a "best video performances according to network conditions regardless energy consumption" mode, having data on the QoE and energy consumption could enable a second mode to be offered to users representing reasonably good video performance with good energy efficiency. Having this information, instead of having a manual selection of video bit rates or SDR/HDR modes, the 5GMS Client could automatically select the best compromise to offer this additional mode to the users.

Regulators like Arcom also encourage TV services, VoD services, video sharing platforms and other actors in the sector to put in place a common methodology for calculating the environmental impact of audiovisual uses. This work will have to follow as the study item plans to study the feasibility of having implementation-independent metrics and a framework to evaluate the energy usage/savings of multimedia standards features and proposals.

6 Key Issues

6.1 Key Issue #1: Energy-related Information exposure

6.1.1 Description

As described in the use cases summarised in clause 5.1, energy-related information needs to be collected, estimated, and exposed by the 5G System. This information is not only necessary for internal network optimisation, but it will also benefit service adaptation by third-party Application Service Providers. With the consent of Mobile Network Operators, it is relevant to expose energy-related information (e.g., energy consumption information, energy efficiency information, renewable energy and carbon emission information) to authorised consumers. TR 23.700-66 [20] study and identify potential enhancements to the 5G System (e.g. including network energy related information exposure, enhancement for subscription and policy control to enable energy efficiency as service criteria) to improve energy efficiency and to support energy saving in the network, taking the Energy requirements in TS 22.261 [5] into consideration. The purpose of this Key Issue is to extend this work, to study and identify potential enhancements to the energy-related information exposure for media architectures, applications and services (e.g., taking into consideration the 5G Media Streaming System according to TS 26.501 [23], 5G Multicast–Broadcast User Services according to TS 26.502 [58], the Real-time Media Communication according to TS 26.506 [59], Split rendering Media session Enabler according to TS 26.565 [65], etc.) including UE-related energy information exposure. As explained in clause 4.2.2, a UE data collection and reporting architecture already exist in the 5G System. But energy-related information is missing.

In this context, the subsequent analysis by this Key Issue should consider:

1. How should UE energy-related information be reported by a UE to the 5G System?
2. Which reference points should be used to report UE energy-related information to the Data Collection AF?
3. Would it be useful to expose energy-related information of the network to the Media Session Handler to help it optimize its media session in an energy-efficient way?
4. How to allow a UE to report its energy-related information without exposing its energy consumption rate?

This analysis will need to take into consideration existing work done in 3GPP but also other market trends. Application Service Providers are often reluctant to deploy solutions specific to mobile networks. Proposing technologies already supported in their services or technologies that are agnostic to the network, or which operate passively without the active involvement or knowledge of applications, are more likely adopted.

6.1.2 Potential requirements

Clause 6.4 in TR 22.882 [56] contains the consolidated requirements extracted from use cases, related to information exposure related with this Key Issue:

[CPR 6.4-1]	Subject to operator's policy and agreement with 3rd party, the 5G system shall be able to expose information on energy consumption for serving this 3rd party.
[CPR 6.4-2]	Subject to operator's policy, the 5G system shall support a means to expose energy consumption to authorized third parties for services, including energy consumption information related to the condition of energy credit limit (e.g. when the energy consumption is reaching the energy credit limit).
[CPR 6.4-3]	Subject to operator policy, the 5G system shall provide means for the trusted 3rd party, to configure which network performance statistic information (e.g. the data rate, packet delay and packet loss) for the communication service provided to the 3rd party, needs to be exposed along with the information on energy consumption for serving this 3rd party.
[CPR 6.4-4]	Based on operator policy and agreement with 3rd party, the 5G system shall be able to expose energy consumption information and prediction on energy consumption of the 5G network per application service to the 3rd party.

[CPR 6.4-5]	Subject to operator's policy and agreement with 3rd party, the 5G system shall support a mechanism for the 3rd party to provide current or predicted energy consumption information over a specific period of time.
-------------	---

Additional potential requirements identified from related work:

[PR 1-1]	Where possible, it is required to reuse existing mechanisms (e.g., UE data collection and reporting architecture as in TS 26.531 [21]) and information for exposure of energy-related information.
[PR 1-2]	It is required to reuse commonly supported client data reporting formats for energy-related information exposure when possible.
[PR 1-3]	It is required that the 5GMS Client is able to obtain energy-related information from the UE, allowing it to optimise the media delivery sessions it is handling in an energy-efficient manner.

6.2 Key Issue #2: Energy-related monitoring and measurement

6.2.1 Description

The measurement of energy consumption by media services is an essential pre-requisite to facilitate efficient energy use and energy saving. The environmental impact of the consumption of media services depends various system actors: equipment manufacturers, networks, datacentre operators, service providers but also users through their usage behaviour.

Requirements of monitoring and measurement relating to energy consumption and efficiency have already been defined by 3GPP in TR 22.882 [56] but those requirements are only related to energy consumption monitoring of the 5G network or 5G System. TR 23.700-66 [20] studies and identifies potential enhancements to the 5G System (e.g. including network energy related information exposure, and enhancement of subscription and policy control to enable energy efficiency as a service criterion) with the dual aims of (i) improving energy efficiency and (ii) supporting energy saving in the network, taking the EnergyServ requirements in TS 22.261 [5] into consideration.

The purpose of this Key Issue is to extend the above work, by studying and identifying potential enhancements to energy-related monitoring and measurement aspects (including UE-related energy information measurement and monitoring) in the context of the following media delivery architectures, applications and services namely the 5G Media Streaming System according to TS 26.501 [23], 5G Multicast–Broadcast User Services according to TS 26.502 [58], the Real-time Media Communication according to TS 26.506 [59], Split rendering Media session Enabler according to TS 26.565 [65], etc.

The most efficient way to address energy saving in this context is to consider the complete end-to-end media delivery chain, seeking to understand how decisions made on one end of the chain impact power consumption on other ends of the workflow. As explained in clause 4.2.2, UE data collection has been defined to monitor QoE in the 5G system. But energy-related information is missing.

NOTE 1: It is presumed that the user has granted consent for its UE data to be collected, reported and subsequently exposed by means outside the scope of the study or following normative work.

NOTE 2: The collection, reporting and exposure of location-based UE data is expected to comply with regional regulatory requirements and may be further limited by MNO policy.

In this context, the subsequent analysis by this Key Issue will consider the following questions:

1. Which UE energy-related information will be collected to measure, correlate, and optimize energy usage across the entire streaming distribution chain?
2. Can existing methods be leveraged to measure/monitor the identified UE energy-related information?
3. Which UE entity is appropriate to measure this UE energy-related information?

This issue is even more important for advanced media services such as XR services, Split Rendered media services, etc. which are expected to incur substantial energy consumption both at the device and network levels, presenting significant challenges for operators and service providers.

For instance, when a Mobile Network Operator (MNO) deploys a communication service to fulfil application service requirements, such as those of a gaming application, it is crucial for the customer – whether an Application Service Provider (ASP) or an industry vertical – to ensure that the application service reduces energy consumption for both end users and the data network. Failure to do so could necessitate short-notice application layer adaptations within the Application Service Provider's domain. This may result in adjustments being made to service levels in response to anticipated high energy consumption in specific service areas or during peak hours that adversely affect the Quality of Experience for service users.

In a practical scenario, an ASP intends to deploy a gaming service within a designated service area, served by an MNO's 5G network. Various service levels may exist, each associated with specific Key Performance Indicators (KPIs), such as automation levels or video quality targets. To ensure energy efficiency the ASP monitors the energy efficiency of its application service across specified service levels. Monitoring of application energy consumption may occur periodically or may be event-triggered, depending on the ASP's requirements, which are typically outlined in the Service Level Agreement (SLA). The MNO and ASP may agree on a certain energy efficiency target for the application service and optionally for given service levels.

This analysis will need to take into consideration existing work done in 3GPP but also other market trends. Application Service Providers are often reluctant to deploy solutions specific to mobile networks. Proposing technologies already supported in their services or technologies that are agnostic to the network, or which operate passively without the active involvement or knowledge of applications, are more likely adopted.

6.2.2 Potential requirements

Clause 6.3 in TR 22.882 [56] contains the consolidated requirements extracted from use cases, related to monitoring and measurement related with this Key Issue:

[CPR 6.3-1] Subject to operator's policy, the 5G network shall support energy consumption monitoring at per network slice and per subscriber granularity.

NOTE 1: Energy consumption monitoring as described in the preceding requirement is done by means of averaging or applying a statistical model. The requirement does not imply that some form of 'real time' monitoring is required. The granularity of the subscription policies can either apply to the subscriber (all services), or to particular services.

[CPR 6.3-2] Subject to operator's policy and agreement with 3rd party, the 5G system shall be able to monitor energy consumption for serving this 3rd party, independently from NG-RAN deployment scenarios.

NOTE 2: The granularity of energy consumption measurement could vary according to different situations, for example, when several services share a same network slice, etc.

NOTE 3: The energy consumption information can be related to the network resources of network slice, NPNs, etc.

[CPR 6.3-3] Subject to operator policy and regulatory requirements, the 5G system shall be able to monitor the energy consumption for serving the 3rd party, together with the network performance statistic information for the services provided by that network, through same update rate e.g. hourly or daily.

NOTE 4: The network performance statistic information could be the data rate, packet delay and packet loss, etc.

Based on TS 28.310 [2] and other related work in 3GPP, the following potential requirements need to be considered in this Key Issue:

[PR 2-1] Where possible, it is required to reuse existing mechanisms (e.g., UE data collection and reporting architecture as in TS 26.531 [21]) and information for measurement and monitoring of energy-related information.

[PR 2-2]	It is required to reuse commonly supported client data metrics for energy-related information measurement and monitoring when possible.
[PR 2-3]	Based on the collected and/or predicted energy efficiency information exposed from the 5G System, the Application Service Provider is able to adapt the application service parameters based on the 5GS feedback. Monitoring of application energy consumption may occur periodically or may be event-triggered, depending on the ASP's requirements, which are typically outlined in the Service Level Agreement (SLA). In order to perform such operations, the Application Service Provider requires relevant APIs to be exposed by participating entities related to the usage of media applications in order to expose Energy efficiency related information. For example, in the case of the 5G Media Streaming collaboration described in clause A.2 of TS 26.501 [23], this depends on the relationship between 5GMS Application Provider, 5GMSd-Aware Application, 5GMSd Client, 5GMSd AF, and 5GMSd AS.

6.3 Key Issue #3: Evaluation framework

6.3.1 Description

The complexity of the media delivery chain raises technical challenges in terms of environmental impact measurement and accountability. There is no explicitly and uniformly defined methodology to evaluate the energy usage/savings of multimedia standards features and proposals which leads to significant variation in the results of different studies. Regulators and legislatures like the European Parliament have already provided more precise guidelines, targeting companies or services, to assess cases of unfair environmental advertising [60].

A characterisation framework to evaluate the energy usage/savings of multimedia standards features and proposals for relevant 3GPP scenarios is also needed to justify claims. The framework presented in this Key Issue is based on the normative work (e.g., granularities or energy-related information) recommended by Key Issues #1 and #2 of the present document, and includes a set of relevant scenarios and anchors. It is not dependent on a particular implementation of the feature or other parts of the system and allows an energy-efficient implementation to be compared against an implementation not relying on the proposed standards feature. The commonly supported external estimation frameworks mentioned in clauses 4.2.3 and 4.2.4 are to be reviewed and agreed by SA WG4 before using them to develop the evaluation framework in this Key Issue.

Characterization of specific media-related technologies has previously been conducted by 3GPP, for example in TR 26.955 [62] on Video Characterization and TR 26.947 [71] on Characterization of Application Layer FEC. Drawing from these frameworks, a foundation for evaluating the energy usage and savings of specific multimedia technology features may be derived.

Some best practices from these earlier characterization frameworks can be summarized as follows:

1. Define representative and relevant scenarios: The evaluation of technologies is expected to be done by selecting scenarios that are typical and representative for the usage of a technology in the context of 3GPP services or media delivery context.
2. Establish clear anchors and metrics: Anchors are used to provide a reference technology, for example an already defined technology in 3GPP (for example H.265/HEVC in the context of TR 26.955 [62] or Raptor codes in the context of TR 26.947 [71]). Metrics need to provide a meaningful indication of the impact of the technology for the desired objective. Preferably, these metrics are derived by well-defined and deterministic measurement.
3. Ensure repeatability: In order to ensure credibility of the anchor and test results, the evaluation is preferably repeatable by an independent evaluator. Repeatability may, for example, be ensured by well-defined reference software.
4. Make technology tests meaningful: If new technologies are evaluated against anchors, the executed tests are expected to be meaningful and comparable to the anchors. Tests also are expected to provide relevant information in the context of the scenario.
5. Provide a reference implementation: In order to provide consistency and repeatability, a reference software implementation that is openly accessible is a beneficial asset.

6. Define a verification and validation process: In order that results have the highest credibility, providing an independent validation framework of them is encouraged, as well as documenting independently verified results. If the results cannot be verified, the validation framework provides the means to identify bugs or inconsistencies and potentially fix them.
7. Define an example characterization: To ensure that the framework is consistent, providing an example characterization is encouraged, i.e. the comparison of defined anchor results with some well-known comparable technology.
8. Work is consensus-based and reason-based: Comparable configurations between anchors and tests are not necessarily easily defined. It is expected that experts can reach consensus on reasonable and comparable configurations. Also, determined metrics may provide objective results, but the interpretation of the results is expected to be based on reasoned arguments, and results should always be viewed in the context of how they were determined.
9. Avoid mixing solution selection and characterization – focus on the latter: Expanding on point 8 above, characterization results primarily support the discussion to evaluate a technology, but are typically not suitable for a technology selection shoot-out because such an ambition may limit consensus-based discussions.
10. Do not strive for a single KPI number; instead collect information to have a basis for argumentation: Also, expanding on point 8 above, the collection of multiple data points allows experts to use the numbers in argumentation. Therefore, more independent metrics support consensus building.
11. Initially, prioritize only one or two scenarios for a more focused approach: Scenarios are typically complex to establish, and hence too many scenarios may not be manageable. A reasonable set of scenarios that are well executed is preferable to an overload of scenarios. In addition to the above best practices, the candidate technology under evaluation will first have to overcome complexities already encountered with past characterization work:
 - Getting good and meaningful and agreeable scenarios and anchors.
 - Implementation dependency.
 - Documentability.
 - Verification and validation: cross validation, test labs, etc.

6.3.2 Potential requirements

[PR 3-1]	Based on the APIs, metrics, and mechanisms available in the 5G System, it is required that a framework is defined to evaluate the energy usage/savings of multimedia standards features and proposals for relevant 3GPP scenarios on which anchors are defined. The tests forming this framework are required to be repeatable and verifiable.
[PR 3-2]	It is required that standardized approaches to estimate the energy usage/savings that have been reviewed and agreed by 3GPP SA WG4 are used in the evaluation framework.

7 Potential Solutions

7.1 Mapping of Solutions to Key Issues

Table 7.1-1: Mapping of solutions to Key Issues

Solutions			
	KI#1	KI#2	KI#3
#1			X
#2			X
#3		X	
#4	X		
#5	X		
#6	X	X	
#7	X		
#8		X	
#9	X		

These solutions are simply candidate solutions. Their inclusion in the following clauses does not imply that they have been agreed upon or endorsed. Any decisions and work to be done for the normative work will be detailed in the conclusions of this Technical Report.

7.2 Solution #1: Evaluation framework based on French regulators' work

7.2.1 Key Issue mapping

This Candidate Solution partially addresses Key Issue#3 (Evaluation Framework) described in clause 6.3.

7.2.2 Functional description

The methodology described in the Arcom/Arcep [61] study (as summarised in clause 4.2.6) is used as a point of departure for designing a UE energy consumption evaluation framework in the context of the present document. However, it is observed that [61] does not include energy consumption during the usage phase of all three tiers of the digital value chain (user devices, networks and data centres). In particular, no metrics or APIs are available today for the network and data centre aspects. Their scopes would be too broad to be addressed. These parts are for further study outside the scope of the present document.

This is not the case for the user device part, because the required metrics and APIs are already available, at least on major smartphones Operating Systems, and are already used by regulators for evaluating the impact of some specific parameters. The ARCOM/ARCEP study [61] demonstrated their usefulness in evaluating the environmental impact of video codecs, video resolutions and frame rates. But this could easily be extended to other parameters such as different access network types (i.e., Wi-Fi, 5G, LTE) or content delivery modes (i.e., unicast, MBS, 5G Broadcast).

For example, the Battery Manager API is available on Android [63], allowing the status of the UE battery to be interrogated by an application without the need for any external network connection. Using this API, it is possible to query the battery status at various points/intervals and to collate results over time to be able to calculate the energy usage of a specific workload. Samples can be taken periodically (e.g. once per second) including the timestamp, instantaneous battery current in microamperes and current battery voltage. From the collection of these data points, the energy (measured in Joules) is calculated as follows:

$$joules = currentInAmps \times timeDifference \times voltage$$

There are a few limitations to measuring energy usage by this method:

1. Other applications or system processes running at the same time may affect the results.

2. The data collection itself service consumes some energy when collecting energy values. This artefact can be negated or controlled for by ensuring certain device conditions.

Contrary to the Test and Characterization Framework for Video Codecs described in TS 26.955 [62], reference software tools are not used in this candidate solution. Real-life implementation is used as the anchor against which specific features are evaluated. Exact results from testing a specific model of device will not be generalised for all devices, nor for all implementations on that device or others.

7.2.3 Procedures

The following methodology is proposed to measure energy consumption in the UE:

1. A test scenario is defined, and test conditions described in terms of:
 - a. Network (connection type, upload and download bandwidth, latency).
 - b. User device (type, model, SoC, OS version, video player).
 - c. Test conditions (test duration, number of iterations, factory setting applied, etc.).
 - d. Anchor against which the specific features will be evaluated (i.e., 5GMS service delivering a 720p video at 2 Mbps in HEVC).
 - e. Reference sequence(s) used.
2. The application under test which implements the reporting of energy-related information is started.
3. The test is done for the anchor and the implementation including the feature evaluated.
 - The measurement period and the number of iterations performed are required to ensure relevance and to limit artefacts relating to the measurement itself.

Two measurement modes are possible, selection is made according to the influence of the caching on the test:

- a. *Systematic content change between iterations.* This has the advantage of avoiding user-side CDN caching strategies but has the disadvantage of introducing variability with different content. This measurement also provides stronger representativeness of user behaviour.
 - b. *Iterations are conducted on a continuously played video.* This has the advantage of controlling for the content, but the disadvantage of potentially underestimating consumption due to caching technologies.
4. Store results for non-real-time analysis.
 5. Characterization is documented in terms of expected energy savings, and may include additional comparison parameters such as impact on the end user's Quality of Experience, etc.

7.2.4 Summary

Collection per-media-application of energy-related information, allowing energy use by certain computational workloads (e.g., battery current and battery voltage) over a cellular network to be measured and analysed offline, is needed.

7.3 Solution #2: Evaluation Framework to measure energy efficiency of a UE

7.3.1 Key Issue mapping

This Candidate Solution addresses Key Issue #3 (Evaluation Framework) described in clause 6.3.

7.3.2 Functional description

7.3.2.1 UE Energy Efficiency metric

Similar to the definition of the Mobile Network Energy Efficiency KPI (see clause 4.2.3.6.2), one possible example to represent the UE energy efficiency is *bits per Joule*. A UE is considered to be more energy-efficient when the data usage (in bits) is high with less energy consumption (in Joules), assuming that battery capacity and consumption rate are fixed when assessed during the time frame (T). The metric is defined as below:

$$EE_{UE} = \frac{\text{Data Volume}}{\sum_{i=\text{power state}} \text{Energy Consumption } (i)}$$

- **Data Volume [bit]** represents the traffic volume for the UE for a given duration.
- **Energy Consumption [estimated Joule]** represents the total energy consumption of the UE for a given duration, which is the summation of power consumption.

The data volume consumed by k sub-applications is defined as the summation of the data volume consumed by the User Equipment under investigation during the time frame T of the energy consumption assessment for these sub-applications. This could be shown as:

$$DV_{k,app} = \sum_{i=1}^k DV$$

where $DV_{k,app}$, measured in bits, is the data volume over the measurement period T of the UE for a given duration.

The overall UE Energy Efficiency, EE_{UE} is then calculated as follows:

$$EE_{UE} = \frac{DV_{k,app}}{\sum_{i=\text{power state}} \text{Energy Consumption } (i)}$$

7.3.3 Procedures

The following methodology is proposed to measure the Energy Efficiency of a test application running on a UE:

1. A test scenario is defined, and test conditions described:
 - a. Network (connection type, upload and download bandwidth, latency).
 - b. User devices (type, model, SoC, OS version, video player). At least 2 devices should be used.
 - c. Test environment (number of devices, number of iterations, etc.).
 - d. Anchor against which the specific features will be evaluated (i.e., 5GMS service delivering a 720p video at 2 Mbps in HEVC).
 - e. Reference sequence(s) used.
2. Launch the application under test which implements the collection of energy-related information, including either battery discharge rate or else total energy discharged and duration.
3. The test is done for the anchor and the implementation including the feature evaluated.

4. Extract data from the data collector for non-real-time analysis. Characterization is documented in terms of expected energy savings, and may include additional comparison parameters such as impact on the end user's Quality of Experience, etc.
5. The time duration of the measurement, denoted as T , shall be one of the following alternatives:
 - Weekly measurement: $T = 7$ days.
 - Monthly measurement: $T = 30$ days.
 - Yearly measurement: $T = 365$ days.

The minimum duration is therefore one week: monthly and yearly measurements are extensions of the basic week test per the guidelines in ETSI ES 203 228 [66].

6. The Energy Consumption of the mobile network is measured by means of metering information provided by utility suppliers or by measurement systems integrated into the mobile network. Moreover, sensors can be used to measure the energy consumption of individual sites or pieces of equipment, following the requirements set by ETSI ES 202 336-12 [68].
7. The data volume is measured using network counters for data volume in the UE under test.
 - For *Packet-Switched traffic*, the data volume is considered as the overall amount of data transferred to and from the UE under test. Data volume is measured separately for each application present in the UE.
 - For *Circuit-Switched traffic* (e.g. CS voice or VoLTE), the data volume is considered as the number of minutes of communications during the time T multiplied by the data rate of the corresponding service and the call success rate per ETSI ES 203 228 [66].

7.3.4 Summary

The Candidate Solution described in clauses 7.2.2 and 7.2.3 has the following limitations:

1. The solution proposes to evaluate the energy efficiency of the entire UE as a whole device, while individual energy consuming aspects such as the media energy consumption, energy consumed during radio transmissions (4G, 5G, Wi-Fi), etc. may have additional impact on the energy efficiency of the UE.
2. The solution is UE implementation-specific, i.e. the same feature may result in different evaluations of energy efficiency on different UEs.
3. The solution may result in different evaluations of energy efficiency of the same UE depending upon the test conditions that may vary over time (e.g. environmental changes and radio conditions, etc.).

7.4 Solution #3: Existing UE energy-related information measurement

7.4.1 Key Issue mapping

This Candidate Solution partially addresses Key Issue#2 (Monitoring and measurement) described in clause 6.2.

7.4.2 Functional description

This solution addresses only energy-related information measurement from the UE; it does not address energy-related information measurement from the network. The two main questions raised in the Key Issue description are about which UE energy related information is collected, and which UE entity is collecting.

Currently, the 5G System does not have access to energy-related information on UEs. Because neither a component external to the UE nor mechanisms requiring debug mode are excluded by the use cases described in clause 5, this candidate solution proposes to use an existing entity allowing to provide energy-related information to the 5G System via existing API.

Most UE Operating Systems already provide tools to assess the energy footprint of applications using system-wide metrics. Different Operating Systems provide different data about energy consumption. However, common basic data are available on two of the three main smartphone OS: Android [63] and Harmony OS [69], enabling the requirements of the Key Issue to be fulfilled. The common basic data between those two OSs are:

- *Charging status*: Battery charging state of the current device. Indicates if the battery is being/not being/fully charged.
- *Voltage*: Instantaneous battery voltage of the device, expressed in unit of microvolts (μV).
- *Current*: Instantaneous current of the device battery, expressed in units of milliamperes (mA).

Using APIs providing this information, the 5GMS Client is able to calculate the energy consumption during media streaming in Joules using the formula:

$$\text{energyInJoules} = \text{currentInAmps} \times \text{timeDifference} \times \text{voltage}$$

However, this method has several key limitations:

- Such public API are not available on iOS.
- Energy consumption during charging phases is not included.

7.4.3 Summary

This Candidate Solution indicates how applications currently measure energy consumption of a smartphone. This has the advantage of answering questions raised in the description of Key Issue #2:

1. Which UE entity is appropriate to measure this UE energy-related information?

Answer: This is done by the UE directly.

2. Which UE energy-related information will be collected to measure?

Answer: The parameters commonly exposed by some smartphone Operating Systems.

However, in the context of this study, this solution has major limitations:

- UE energy-related information is not publicly available on all UE Operating Systems, including some major ones (e.g., iOS)
- This energy-related information is related to the entire smartphone, and is not limited to media consumption.
- Accuracy of information provided by the APIs is uncertain and likely to vary between different devices.

7.5 Solution #4: Energy-related information exposure from UE

7.5.1 Key Issue mapping

This Candidate Solution addresses Key Issue #1.

7.5.2 Functional description

7.5.2.1 Introduction

This Candidate Solution to Key Issue #1 proposes potential methods for collecting energy-related information on the UE and subsequently reporting it to the network, enhancements to the entities involved in obtaining relevant information, and the impact of them on taking into consideration the media context (e.g., the 5G Media Streaming System defined in TS 26.501 [23], 5G Multicast–Broadcast User Services as defined in TS 26.502 [58], the Real-time Media Communication System defined in TS 26.506 [59], split rendering Media Session Enabler as specified in TS 26.565 [65], etc. including UE-related energy information exposure.

7.5.2.2 UE energy-related information collection and reporting functionality

7.5.2.2.1 Generic UE energy-related information collection and reporting

Clause 6.2.8 of TS 23.288 [70] envisages a set of high-level procedures by which data is collected by a Network Data Analytics Function (NWDAF) from UE Application(s) via an intermediary Direct Data Collection Client residing in the UE and an Application Function residing in the Data Network that provides an Event Exposure service to *event consumers*. A reference architecture satisfying these requirements is defined in TS 26.531 [21].

To obtain and maintain the UE energy-related information, a new generic functionality in the UE called the *Energy-Related Information Collection and Reporting entity* is defined within the Direct Data Collection Client as illustrated in figure 7.5.2.2.1-1. This entity is responsible for collecting and reporting energy-related information in the UE.

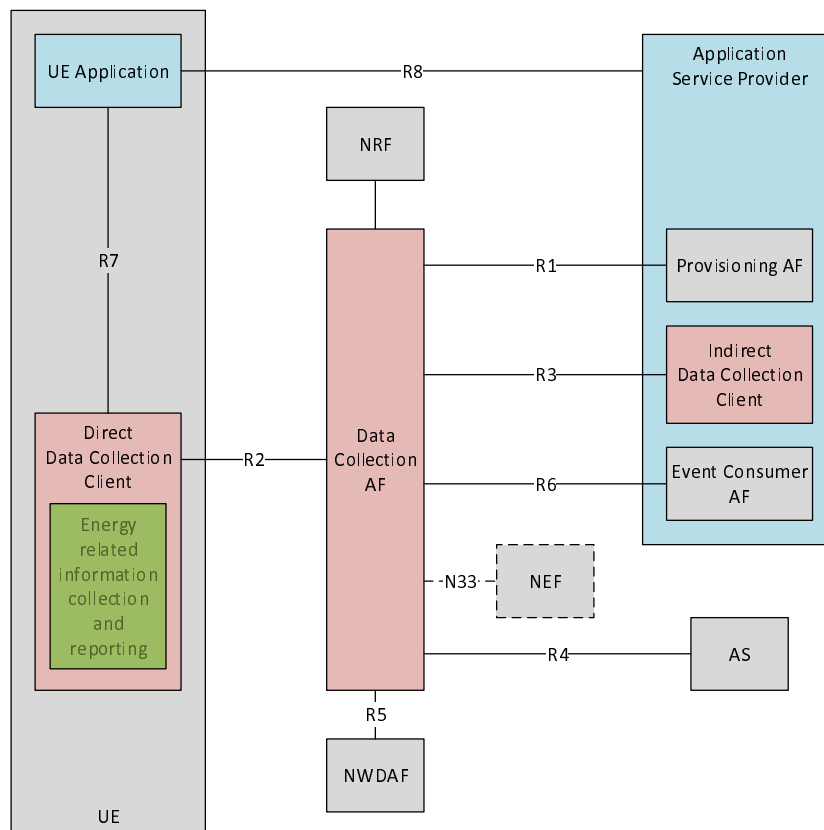

Figure 7.5.2.2.1-1: UE energy information handler entity within generic Direction Data Collection Client

Based on the generic architecture for UE data collection, reporting and event exposure defined in TS 26.531 [21], figure 7.5.2.2.1-1 shows different interfaces between the UE and the Data Network, including the new *UE Energy-Related Information Collection and Reporting* functionality in the Direct Data Collection Client. In this case, UE energy-related information is reported to the Data Collection AF at reference point R2 for onward exposure to the NWDAF (at reference point R5) or to the Application Service Provider's Event Consumer AF (at reference point R6).

As described in clause 4.1 of TS 26.531 [21], the Data Collection AF is responsible for receiving data reports –the scope of which is extended by this candidate solution to include energy-related information reports – from UEs pertaining to a particular UE data domain, for processing the UE data contained in those reports, and for exposing them to subscribed event consumers in the form of *events*.

7.5.2.2.2 Instantiation of UE energy-related information collection and reporting in the 5G Media Streaming architecture

When the Direct Data Collection Client is instantiated in the 5G Media Streaming System per clause 4.7.1 of TS 26.501 [23], the UE Energy Related-Information Collection and Reporting functionality is a subfunction of the Media session Handler and plays the role of UE energy information collection and reporting to the Data Collection AF instantiated inside the 5GMS AF. This instantiation in the 5GMS architecture is illustrated in figure 7.5.2.2.2-1.

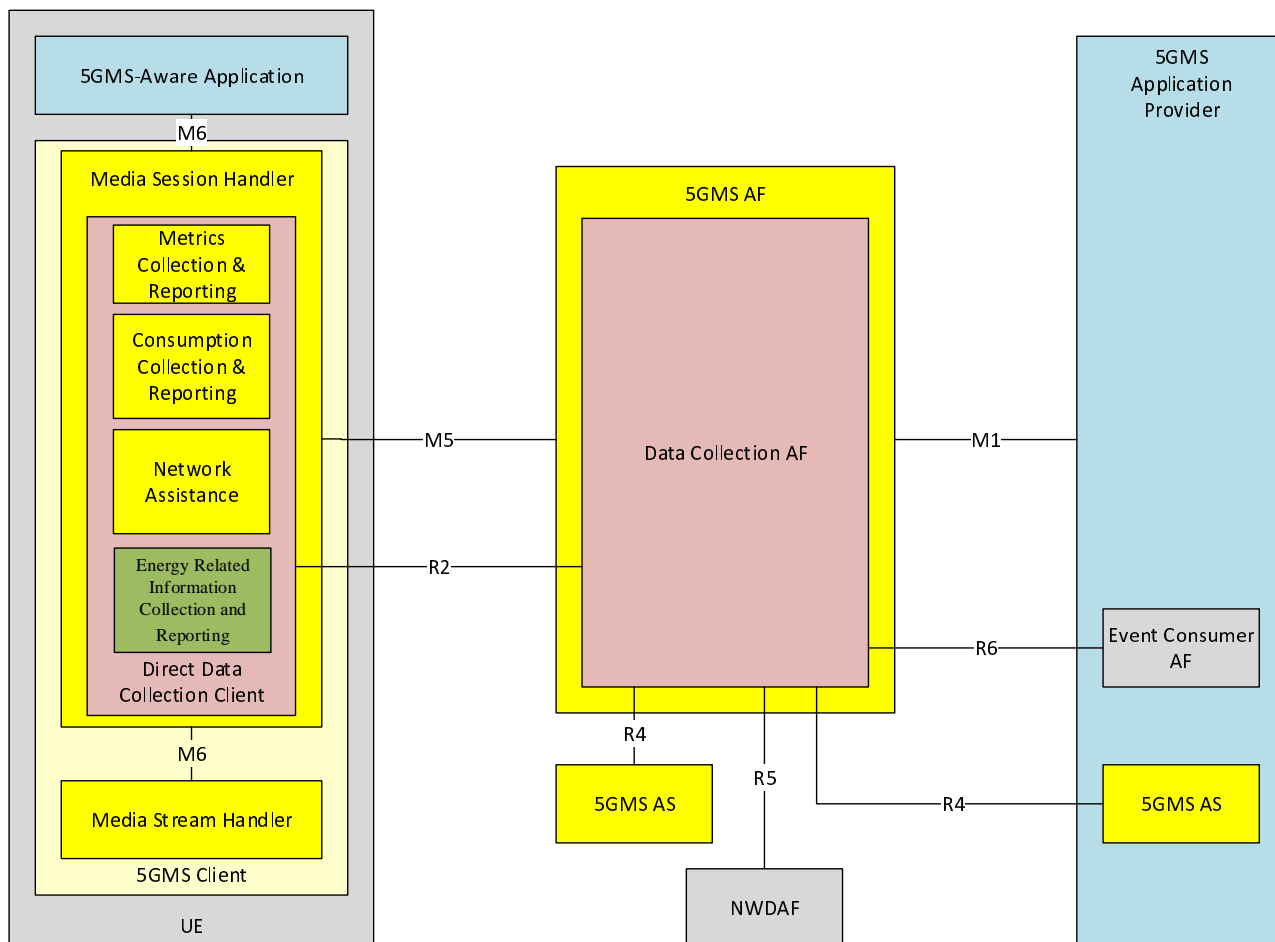
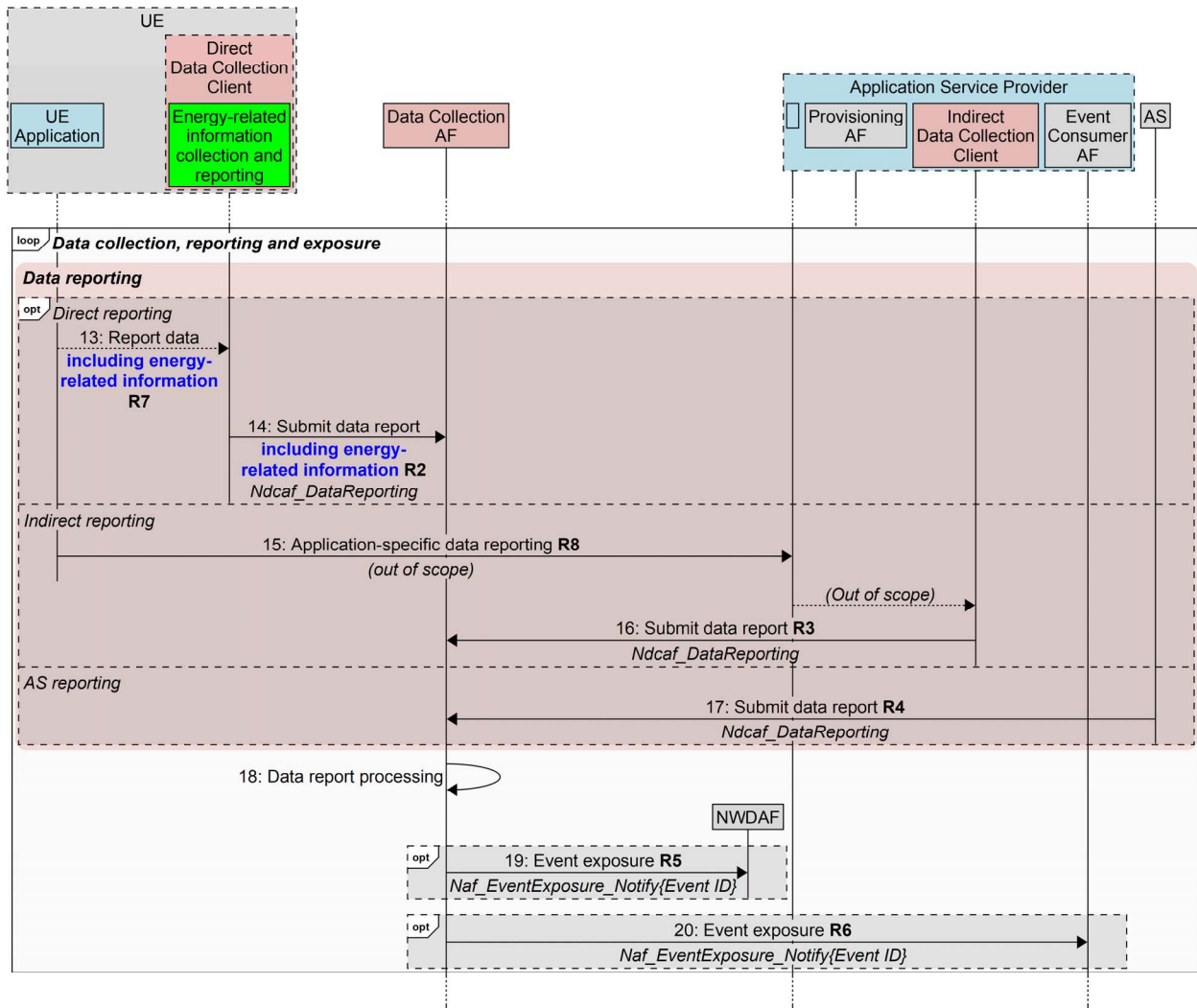

Figure 7.5.2.2.2-1: UE energy information handler entity instantiated within 5GMS Media Session Handler

7.5.3 Procedures

The high-level procedure for data collection and reporting, including energy-related information is the same as that defined in clause 5.1 of TS 26.531 [21] and the detailed call flow for reporting to the Data Collection AF is the same as that defined in clause 5.5 of [21] except the UE data report includes energy-related information.



<https://gitlab.com/msc-generator/v8.6.1>

Figure 7.5.3-1: High-level procedures for UE energy-related data reporting and exposure phase

As specified in clause 6.2.8.2.1 of TS 23.288 [70], both the direct reporting procedure and indirect reporting procedure are required to be supported. The indirect reporting procedure may be used when a Direct Data Collection Client is not available in the UE or when the Indirect Data Collection Client needs to modify the collected UE data to satisfy the requirements of its data collection and reporting configuration.

Steps 1 to 12 are the same as those in clauses 5.2, 5.3, 5.4 of TS 26.531 [21]. The three different data collection clients then proceed as follows, with differences from the baseline call flow highlighted in **boldface**:

13. If present in the instantiation, the UE Application reports data to the Direct Data Collection Client according to the configuration provided in step 10 of clause 5.4 of TS 26.531 [21] for inclusion in a data report including energy-related information. The UE application may instruct the Direct Data Collection Client to prioritise immediate delivery of a UE data report **including per-application UE energy-related information** to the Data Collection AF.

14. The Direct Data Collection Client may submit a data report **including per-application UE energy-related information** to the Data Collection AF via reference point R2 by invoking the *Ndcaf_DataReporting* service defined in TS 26.531 [21] and specified in TS 26.532 [22]. The Direct Data Collection Client may indicate that the data report includes UE data requiring expedited processing by the Data Collection AF.
15. The UE Application may send application-specific data reporting **including per-application UE energy-related information** to the Application Service Provider.
16. ...and the Indirect Data Collection Client may, as a result, submit a data report **including per-application UE energy-related information** to the Data Collection AF by invoking the *Ndcaf_DataReporting* service defined in TS 26.531 [21] and specified in TS 26.532 [22].
17. The AS may submit a data report to the Data Collection AF by invoking the *Ndcaf_DataReporting* service defined in the present document and specified in TS 26.532 [22].

In response to receiving a data report:

18. The Data Collection AF processes the **per-application UE energy-related information in the** data report.

Reception of a data report by the Data Collection AF may result in an event being exposed to subscribed event consumers:

19. The Data Collection AF may expose a **UE energy consumption** event to the NWDAF by invoking the *Naf_EventExposure_Notify* service operation on the latter, as defined in clause 5.2.19.2.4 of TS 23.502 [40].
20. The Data Collection AF may expose a **UE energy consumption** event to the Event Consumer AF by invoking the *Naf_EventExposure_Notify* service operation on the latter, as defined in clause 5.2.19.2.4 of TS 23.502 [40].

7.5.4 Impacts on existing services, entities and interfaces

7.5.4.1 Direct Data Collection Client

- Collect and report per-application UE energy-related information to the Data Collection AF according to the procedures described in clause 7.2.3 of the present document.

7.5.4.2 Data Collection AF

- Expose UE energy-related information events according to the procedures described in clause 7.2.3 of the present document.

7.6 Solution #5: Energy-related information from the network and other Service Provider entities provided to a UE application and Application Service Provider

7.6.1 Key Issue mapping

This Candidate Solution addresses Key Issue #1 (Energy-related Information exposure) described in clause 6.1.

7.6.2 Functional description

7.6.2.1 Introduction

This Candidate Solution addresses how energy-related information from the device, the network and other components of the content delivery system can be provided to a UE application during media consumption for exposure to the user. The exposure of the energy-related information is enabled or disabled by the Application Service Provider over time and is expressed using an Energy Information Exposure Specification as envisaged by the Candidate Solution in clause 7.8.

7.6.2.2 Generic reference architecture for collection and exposure of energy-related information

Figure 7.6.2.2-1 depicts a reference architecture that realises this candidate solution in the general (i.e., non-media-specific) case.

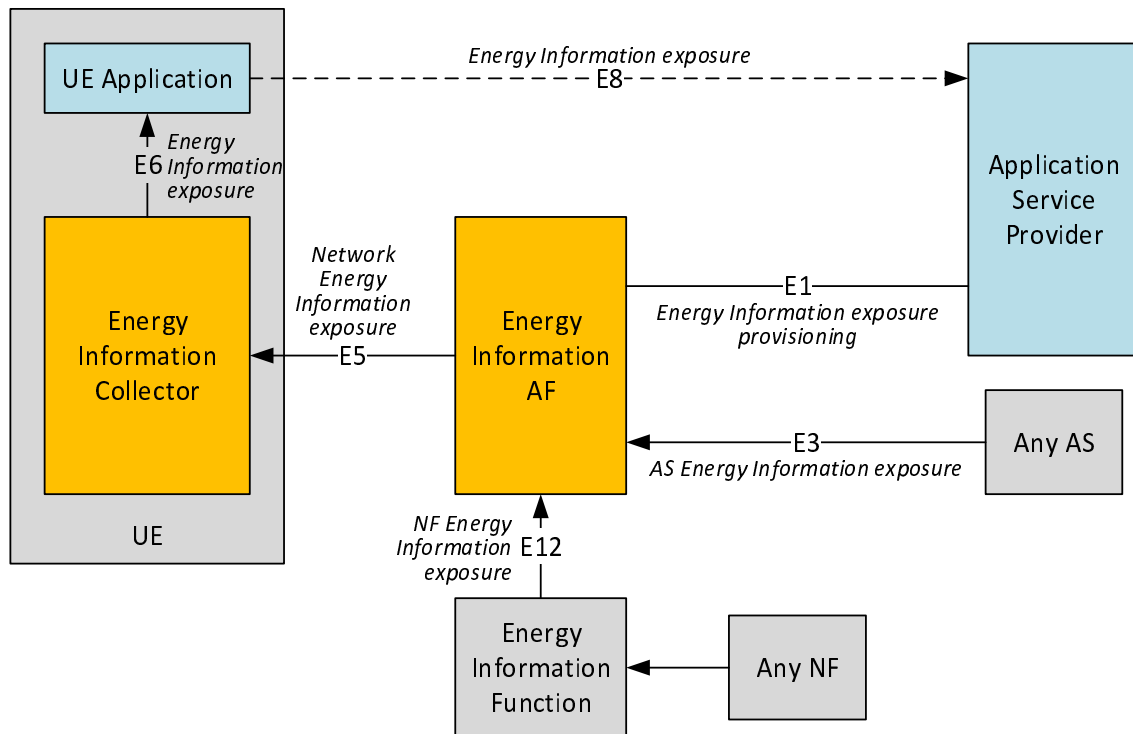

Figure 7.6.2.2-1: Generic reference architecture for collection and exposure of energy-related information

The following functions are defined in this generic reference architecture:

- The *Energy Information AF* is an Application Function in the Data Network with some or all of the following responsibilities, depending on its current provisioning state:
 - Validates the provisioning of an Energy Information Exposure Specification which represents the configuration of the Energy Information required to be exposed to the Application Service Provider (see clause 7.8). The Energy Information Exposure Specification allows the Application Service Provider to define the Energy Information to be exposed to the UE Application, and thus to the subscriber.
 - Subscribes to and consumes *NF Energy Information* from the Energy Information Function as defined in TS 23.501 [72]) with required granularities (UE, PDU session and/or QoS flow) in accordance with the parameters of the Energy Information Exposure Specifications.
 - Subscribes to and consumes *AS Energy Information* from the Application Server in accordance with the parameters of the Energy Information Exposure Specification.
 - Collates, prepares and exposes the above Network Energy Information to the Energy Information Collector in the UE via the data plane in accordance with the Energy Information Exposure Specification.
- The *Energy Information Collector* is a UE function with some or all of the following responsibilities, depending on its current configuration:
 - Acquires an Energy Information collection configuration derived from the Energy Information Exposure Specifications provisioned by all Application Service Providers from the Energy Information AF embedded in Service Access Information obtained from the Media AF by the Media Session Handler. The Energy Information collection configuration may direct the Energy Information Collector to collect energy information from the UE at different granularities, e.g. UE, PDU Session and/or QoS flow, as described in clause 5.51.2.3 of TS 23.501 [72] and/or for individual applications.

- Subscribes to and consumes Network Energy Information from the Energy Information AF according to the Energy Information collection configuration (and hence all the Energy Information Exposure Specifications).
- Collects UE Energy Information from other UE functions and about itself according to the Energy Information collection configuration (and hence all the Energy Information Exposure Specifications).
- Collates and exposes collected energy-related information to the UE Application via a client API in accordance with the parameters of the Energy Information Exposure Specification provisioned by the relevant Application Service Provider.

The following reference points are defined in this generic reference architecture:

- E1 Network API used by the Application Service Provider to provision the Energy Information AF. This determines whether and which NF Energy Information and/or AS Energy Information is collected by the Energy Information AF, and which UEs are entitled to consume it expressed as the parameters of the Energy Information Exposure Specification.
- E12 NF Energy Information exposed by the Energy Information Function (as defined in TS 23.501 [72]) is consumed by the Energy Information AF using a Network API according to the latter's provisioning state.
- E3 AS Energy Information exposed by the Application Server is consumed by the Energy Information AF using a Network API according to the latter's provisioning state.
- NOTE: Subject to the final design of the Energy Information Function in TS 23.501 [72], reference point E3 is not required if AS Energy Information falls within the scope of reference point E12.
- E5 Network API used by the Energy Information Collector in the UE to subscribe to and receive Network Energy Information from the Energy Information AF. Network Energy Information exposed to the Energy Information Collector relates to a specific Application Service Provider.
- E6 Client API used by the UE Application to subscribe to energy-related information notifications from the Energy Information Collector.
- E8 Network API used by the Application Service Provider to receive energy-related information from the UE Application. This reference point is beyond the scope of 3GPP standardisation.

7.6.2.3 Instantiation in 5G Media Streaming architecture

Figure 7.6.2.3-1 illustrates how the generic reference architecture for collecting and exposing energy-related information could be instantiated in the 5G Media Streaming architecture defined in TS 26.501 [23].

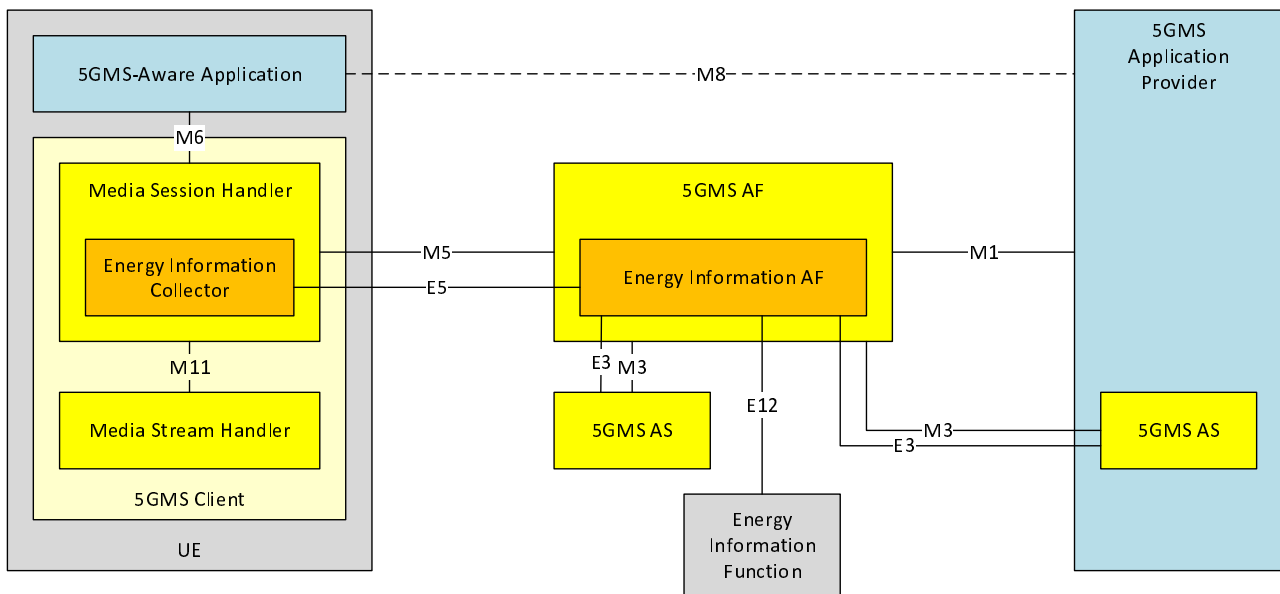

Figure 7.6.2.3-1: Instantiation of generic reference architecture for collection and exposure of energy-related information in the 5GMS System

The following functions are defined in this instantiation of the generic reference architecture:

- The *Energy Information AF* is instantiated in the 5GMS AF and has some or all of the following responsibilities, depending on its current provisioning state **obtained from the 5GMS AF** (which includes the Energy Information Exposure Specification provisioned by 5GMS Application Providers – see clause 7.8):
 - Subscribes to and consumes *NF Energy Information* from the Energy Information Function (as defined in TS 23.501 [72]) according to the Energy Exposing Specification.
 - Subscribes to and consumes *AS Energy Information* from the Application Server according to the Energy Information Exposure Specifications.
 - Collates and exposes the above Network Energy Information to the Energy Information Collector in the UE via the data plane.
- The *Energy Information Collector* is instantiated in the **Media Session Handler of the 5GMS Client** and has some or all of the following responsibilities, depending on its current configuration:
 - Acquires an Energy Information collection configuration derived from the Energy Information Exposure Specifications provisioned by all Application Service Providers from the Energy Information AF **embedded in Service Access Information obtained from the 5GMS AF by the Media Session Handler**. The Energy Information collection configuration may include configuration directing the Energy Information Collector to collect energy consumption information from the UE at different granularities, e.g. UE, PDU Session and/or QoS flow, as described in clause 5.51.2.3 of TS 23.501 [72] and/or for individual applications.
 - Subscribes to and consumes Network Energy Information from the Energy Information AF according to the Energy Information collection configuration (and hence all the Energy Information Exposure Specifications).
 - Collects UE Energy Information **from the Media Stream Handler and from the Media Session Handler** according to the Energy Information collection configuration (and hence all the Energy Exposing Specifications).
 - Collates and exposes collected energy-related information to the **5GMS-Aware Application** via a client API in accordance with the parameters of the Energy Information Exposure Specification provisioned by the relevant 5GMS Application Provider.

The following reference points are defined in this instantiation of the generic reference architecture:

- E1 This reference point is not instantiated: the Energy Information AF is instead provisioned via reference point M1.
- M1 Network API used by the **Media Application Provider** to provision the Energy Information AF **via the 5GMS AF**. This determines whether and which NF Energy Information and/or AS Energy Information **pertaining to the 5GMS AS** is collected by the Energy Information AF, and which UEs are entitled to consume it.
- NOTE 1: The service API at reference point M1 may be similar to that at reference point E1 in the generic reference architecture described in clause 7.6.2.2.
- E12 This reference point is used per clause 7.6.2.2 of the present document.
- M3 After configuration of the Content Hosting and/or Content Publishing and/or Content Preparation, features by the 5GMS AF, the 5GMS AS obtains a **media-specific** Energy Information collection configuration from the Energy Information AF **instantiated in the 5GMS AF**. **The configuration information is embedded in Service Access Information**.
- E3 This reference point is used per clause 7.6.2.2 of the present document. **In this instantiation, the entity exposing AS Energy Information to the Energy Information AF is the Media AS and the AS Energy Information may include the media delivery session identifier**.
- NOTE 2: Subject to the final design of the Energy Information Function in TS 23.501 [72], reference point E3 is not required if AS Energy Information falls within the scope of reference point E12.
- M5 Network API used by the **Media Session Handler** to obtain a **media-specific** Energy Information collection configuration from the Energy Information AF **instantiated in the 5GMS AF**. **The configuration information is embedded in Service Access Information**.
- NOTE 3: The Energy Information collection configuration may be similar to that exposed at reference point E5 in the generic reference architecture described in clause 7.6.2.2.
- E5 This reference point is used per clause 7.6.2.2 of the present document. **The Energy Information Collector is instantiated in the Media Session Handler and the media-specific Energy Information collection configuration is instead acquired in Service Access Information via reference point M5 (see above). Media-specific energy-related information exposed to the Media Session Handler relates to a specific media delivery session in the context of a specific 5GMS Application Provider**.
- M11 Client API used by the Energy Information Collector to collect UE Energy Information from the **Media Access Client**.
- E6 This reference point is not instantiated: the energy-related information is instead exposed to applications via reference point M6.
- M6 Client API used by the **Media-aware Application** to subscribe to energy-related information notifications from the Energy Information Collector, limited by the Energy Information Exposure Specification conveyed as part of the **media-specific** Energy Information collection configuration at reference point M5. **Notifications correlate UE Energy Information collected from the Media Access Client, AS Energy Information collected from the Media AS and NF Energy Information collected from relevant 5G Core Network Functions with individual media delivery sessions**.
- NOTE 4: The client API at reference point M6 may be similar to that at reference point E6 in the generic reference architecture described in clause 7.6.2.2.
- E8 This reference point is not instantiated: the energy-related information is instead exposed via reference point M8.
- M8 Network API used by the **Media Application Provider** to receive energy-related information from the **Media-aware Application**. This reference point is beyond the scope of 3GPP standardisation.

7.6.2.4 Instantiation in generalised Media Delivery architecture

Figure 7.6.2.4-1 illustrates how the generic reference architecture for collecting and exposing energy-related information could be instantiated in the generalised Media Delivery architecture defined in TS 26.501 [23] and TS 26.506 [59].

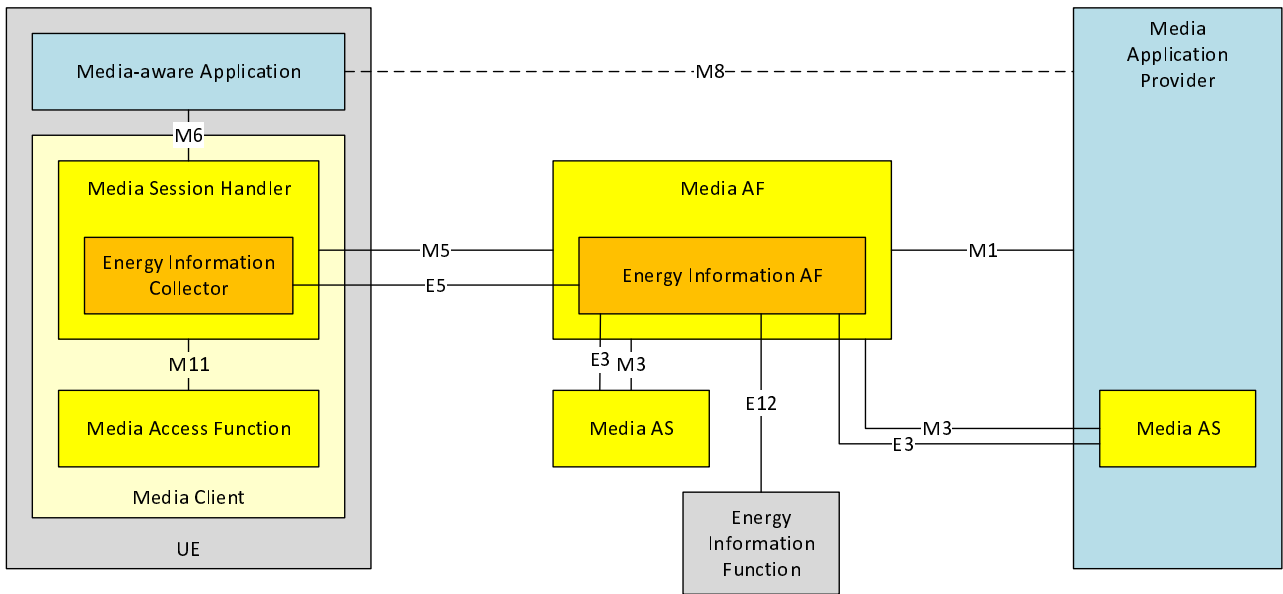

Figure 7.6.2.4-1: Instantiation of generic reference architecture for collection and exposure of energy-related information in the generalised Media Delivery System

Details of the functions and reference points are similar to those described in clause 7.6.2.3.

7.6.3 Procedures

7.6.3.1 Generic high-level procedures for collection and exposure of energy-related information

Figure 7.6.3.1-1 below details the different steps for energy-related information collection and reporting in the system outlined in clause 7.6.2.2.

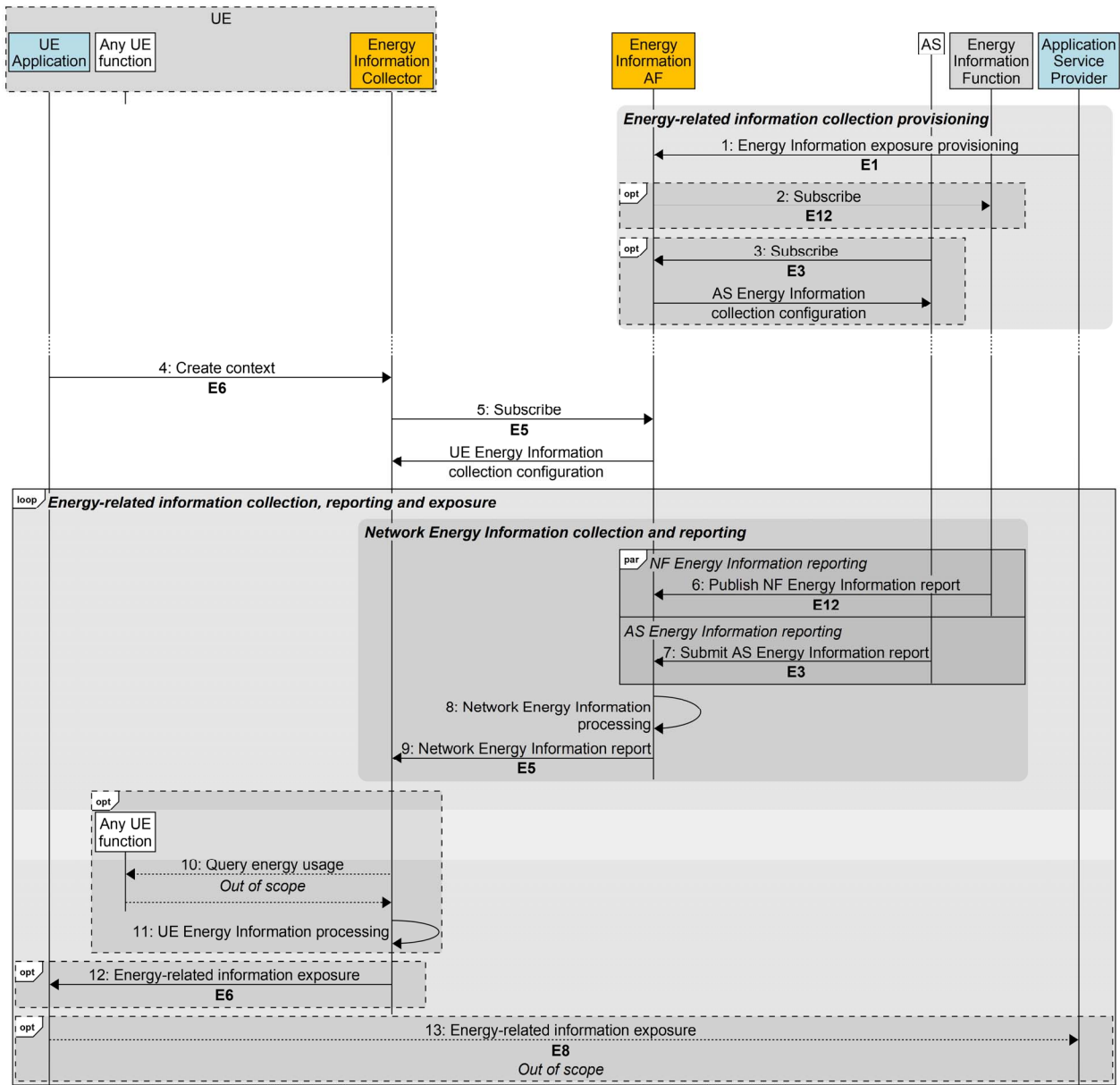

<https://gitlab.com/msc-generator> v8.6.1

Figure 7.6.3.1-1: Procedures for energy-related information collection and reporting

A first step is required to provision Energy Information Collection:

1. The Application Service Provider provisions the Energy Information AF with an Energy Information Exposure Specification via reference point E1. The Energy Information exposure configuration may identify application(s) that fall within its scope.
2. The Energy Information AF subscribes to receive Network Energy Information reporting from the Energy Information Function via reference point E12, if relevant, in accordance with the set of parameters in the Energy Information Exposure Specification.

3. The AS obtains an AS Energy Information collection configuration from the Energy Information AF via reference point E3, if relevant, in accordance with the set of parameters in the Energy Information Exposure Specification. This includes a callback endpoint on the Energy Information AF for submitting AS Energy Information reports.

NOTE: This step requires further discussion. What stimulates the subscription is for further study, c.f. step 5 below.

At some later point:

4. The UE Application creates an Energy information collection and reporting context with the Energy Information Collector via reference point E6.
5. The Energy Information Collector subscribes to Network Energy Information reporting from Energy Information AF via reference point E5, if relevant, and receives in response a UE Energy Information collection configuration in accordance with the set of parameters in the Energy Information Exposure Specifications.

After this initialisation phase, reporting can be done:

6. The Energy Information Function may submit a Network Energy Information report to the Energy Information AF via reference point E12. The Network Energy Information report may include energy consumption information of different granularities, e.g. UE, PDU Session and/or QoS Flow, as described in clause 5.51.2.3 of TS 23.501 [72].
7. The AS may submit an AS Energy Information report to the Energy Information AF via reference point E3 using the callback endpoint supplied in step 3. The AS Energy Information report may include energy consumption information of different granularities, e.g. UE, PDU Session and/or QoS Flow, as described in clause 5.51.2.3 of TS 23.501 [72].
8. The Energy Information AF processes the energy-related information report(s) it has received.
9. The Energy Information AF exposes a processed Network Energy Information report about the UE to the Energy Information Collector subscriber via reference point E5. The Network Energy Information report may include energy consumption information of different granularities, e.g. PDU Session and/or QoS Flow, as described in clause 5.51.2.3 of TS 23.501 [72].
10. The Energy Information Collector may collect additional UE Energy Information from any UE function using methods beyond the scope of 3GPP standardisation, but in accordance with the set of parameters in the Energy Information Exposure Specification conveyed as part of the Energy Information collection configuration obtained in step 5.
11. The Energy Information Collector processes the UE-related Energy Information it has obtained in the previous step.
12. The Energy Information Collector exposes energy-related information to the subscribed UE Application via reference point E6. Based on the UE Energy Information collection configuration obtained in step 5, the energy-related information report may include energy consumption information of different granularities, e.g. PDU Session and/or QoS Flow, as described in clause 5.51.2.3 of TS 23.501 [72] and/or for individual applications.
13. The UE Application may expose the received energy-related information to the Application Service Provider via reference point E8 using methods beyond the scope of 3GPP standardisation.

7.6.3.2 5GMS high-level procedures for collection and exposure of energy-related information

Figure 7.6.3.2-1 below details the different steps for energy-related information collection and reporting in the context of the 5GMS System defined in TS 26.501 [23] and as extended in clause 7.6.2.3 of the present document.

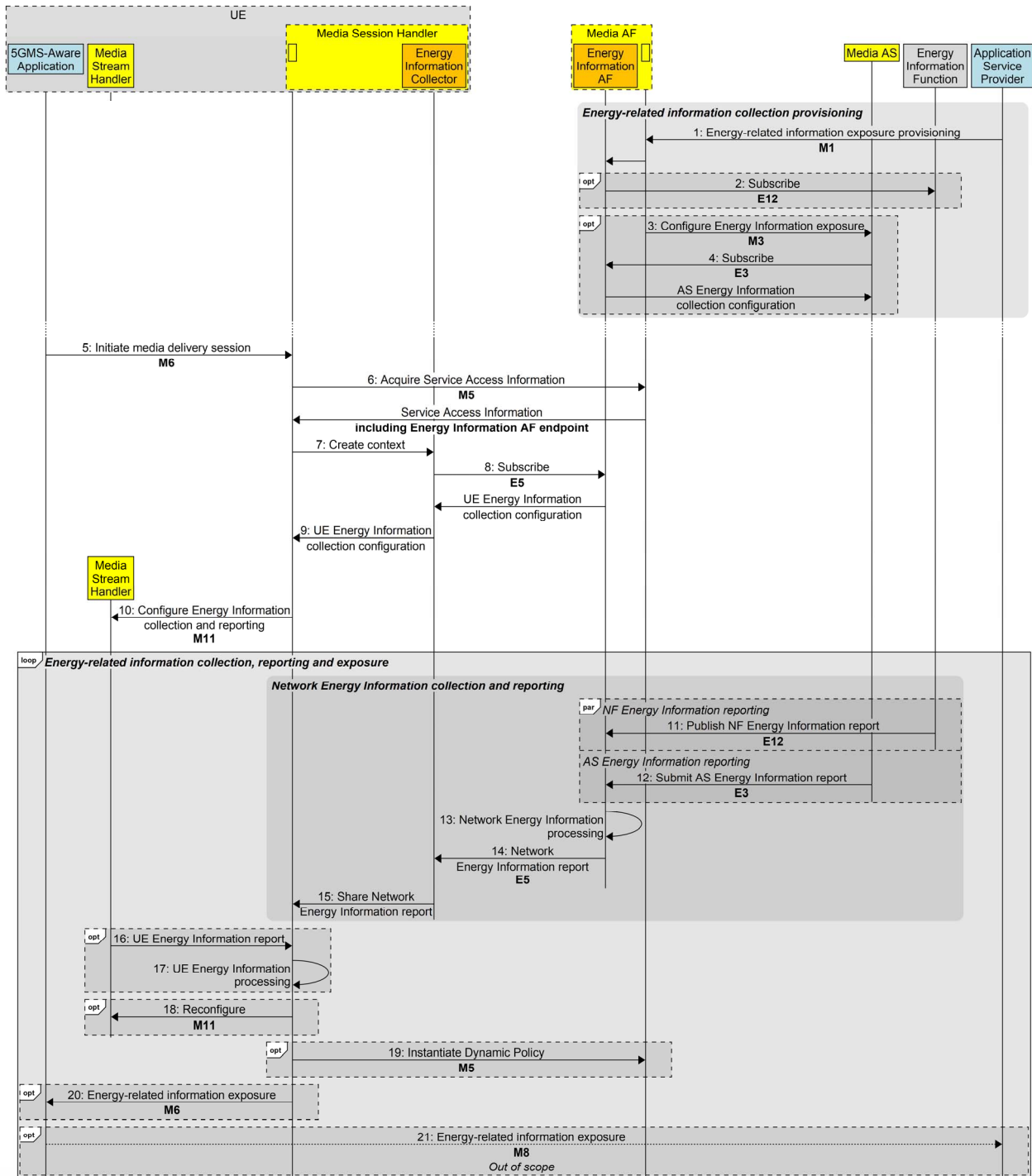

<https://gitlab.com/mmc-generator> v8.6.1

Figure 7.6.3.2-1: Procedures for energy-related information collection and reporting in the 5GMS System

A first step is required to provision Energy Information Collection:

1. The 5GMS Application Provider provisions the 5GMS AF via reference point M1, **including an Energy Information exposure configuration intended for the Energy Information AF instantiated in the 5GMS AF**. The Energy Information exposure configuration may identify application(s) that fall within its scope.
2. **The Energy Information AF subscribes to receive NF Energy Information reporting from the Energy Information Function via reference point E12, if relevant.**
3. The 5GMS AF configures the 5GMS AS via reference point M3, **including details of the Energy Information AF instantiated in the 5GMS AF**.
4. Based on configuration received from the 5GMS AF in the previous step, **the 5GMS AS obtains an AS Energy Information collection configuration from the Energy Information AF via reference point E3, if relevant. This includes a callback endpoint on the Energy Information AF for submitting AS Energy Information reports.**

At some later point:

5. The 5GMS-Aware Application initiates a new media delivery session with the Media Session Handler via reference point M6, **including a request to enable energy-related information collection and reporting.**
6. The Media Session Handler obtains Service Access Information from the 5GMS AF, **including access details of the Energy Information AF**.
7. **As a consequence of the previous step, the Media Session Handler creates a new energy-related information collection and reporting context with the Energy Information Collector instantiated in it.**
8. **The Energy Information Collector subscribes to Network Energy Information reporting from Energy Information AF via reference point E5, if relevant, and receives in response a UE Energy Information collection configuration.**
9. **The Energy Information Collector shares the UE Energy Information collection configuration with the Media Session Handler.**
10. **Based on the UE Energy Information collection configuration received in the previous step, the Media Session Handler configures UE Energy Information collection and reporting in the Media Stream Handler via reference point M11.**

After this initialisation phase, reporting can be done:

11. **The Energy Information Function may submit an NF Energy Information report to the Energy Information AF via reference point E12. The NF Energy Information report may include energy consumption information of different granularities, e.g. UE, PDU Session and/or QoS Flow, as described in clause 5.51.2.3 of TS 23.501 [72].**
12. **The 5GMS AS may submit an AS Energy Information report to the Energy Information AF via reference point E3 using the callback endpoint supplied in step 4. The AS Energy Information report may include energy consumption information of different granularities, e.g. UE, PDU Session and/or QoS Flow, as described in clause 5.51.2.3 of TS 23.501 [72].**
13. **The Energy Information AF processes the energy information report(s) it has received.**
14. **The Energy Information AF exposes a processed Network Energy Information report about the UE to the Energy Information Collector subscriber established in step 5 via reference point E5. The Network Energy Information report may include energy consumption information of different granularities, e.g. PDU Session and/or QoS Flow, as described in clause 5.51.2.3 of TS 23.501 [72].**
15. **The Energy Information Collector shares the report received in the previous step with the Media Session Handler.**
16. **The Media Session Handler may collect additional UE Energy Information about the media delivery session from the Media Stream Handler via reference point M11. Based on the UE Energy Information**

collection configuration obtained in step 6, the UE Energy Information report may include energy consumption information of different granularities, e.g. PDU Session and/or QoS Flow, as described in clause 5.51.2.3 of TS 23.501 [72].

16. The Media Session Handler processes the UE Energy Information it has obtained in the previous step.

17. The energy-related information received by the Energy Information Collector is shared with the enclosing Media Session Handler.

18. Based on the energy-related information received in step 17, the Media Session Handler may reconfigure the Media Stream Handler to change its streaming behaviour (e.g. change its streaming bit rate).

NOTE 1: Details of Media Stream Handler reconfiguration in response to energy-related information are for further study.

19. Based on the Energy Information received in step 17, the Media Session Handler may instantiate a Dynamic Policy with a different energy usage profile.

NOTE 2: Details of Dynamic Policy changes in response to energy-related information are for further study.

20. The Media Session Handler exposes energy-related information to the subscribed 5GMS-Aware Application via reference point M6. Based on the UE Energy Information collection configuration obtained in step 6, the energy-related information may include energy consumption information of different granularities, e.g. PDU Session and/or QoS flow, as described in clause 5.51.2.3 of TS 23.501 [72] and/or for individual media delivery sessions.

21. The 5GMS-Aware Application may expose the received energy-related information to the Application Service Provider via reference point M8 using methods beyond the scope of 3GPP standardisation.

7.6.4 Summary

This Candidate Solution describes how energy-related information from the device, the network and other components of the Media Delivery system can be provided to a UE application during media consumption for exposure to the user and/or to the Application Service Provider.

This solution is based on Network Energy Information available from the Energy Information Function as well as the definition of two new entities, with their associated reference points, allowing the Network Energy Information to be complemented and delivered to the UE application:

- The *Energy Information AF* has some or all of the following responsibilities, depending on its current provisioning state:
 - Subscribes to and consumes NF Energy Information from the Energy Information Function.
 - Receives AS Energy Information reports from the Application Server.
 - Collates and exposes the above Network Energy Information to the Energy Information Collector in the UE via the data plane.
- The *Energy Information Collector*, is a UE function with some or all of the following responsibilities, depending on its current configuration:
 - Acquires an Energy Information collection configuration from the Energy Information AF.
 - Subscribes to and consumes Network Energy Information from the Energy Information AF according to the Energy Information collection configuration.
 - Collects UE Energy Information from other UE functions and about itself according to the Energy Information collection configuration.
- Collates and exposes collected Energy Information to the UE Application via a client API.

7.7 Solution #6: QMC-based monitoring and measurement

7.7.1 Key Issue mapping

This Candidate Solution addresses Key Issue #1 and Key Issue #2 using the QoE Measurement Collection (QMC) functionality summarised in clause 4.2.2.5.

7.7.2 Functional description

7.7.2.1 Introduction

There is currently no solution enabling to monitor energy-saving actions at the application layer and in the RAN access stratum based on information provided by the application layer on the UE. To this end, an energy consumption-aware mechanism for media handling and delivery (in both uplink and downlink directions) based on QoE metrics collection, configuration and reporting is proposed here for different types of media services. The mechanism for media handling and delivery includes UE-side and network-side operations according to the reported energy consumption information.

This Candidate Solution focuses on the energy consumption monitoring. As a result of collecting and evaluating energy-related measurements on the UE, energy consumption in the network may be reduced, thus triggering network energy savings. A typical use case is for the network (potentially acting on behalf of an application) to initiate a campaign of UE energy measurements in order to evaluate the impacts of a specific action taken (e.g. updating some parameters of a media delivery session). In particular, in the context of QoE measurement, the network, or an application, can appreciate the relationship between QoE and energy consumption on the UE, that is to look for an optimum configuration that would save most energy on the UE whilst preserving the target QoE (trade-off).

In this context, this Candidate Solution proposes a method leveraging energy consumption information to monitor and measure the way the media content is handled and delivered to the users, and to provide better Quality of Experience (QoE) for users. Specifically, this Candidate Solution focuses on extending the UE QoE reporting mechanism with energy-related information.

7.7.2.2 MTSI Quality of Experience (QoE) metrics

MTSI Quality of Experience (QoE) metrics is a relevant background for this Candidate Solution. As defined in TS 26.114 [26], the metrics are valid for speech, video and text media, and are calculated for each measurement resolution interval "Measure-Resolution". They are reported to the OAM or QoE server via the gNodeB according to the measurement reporting interval "Sending-Rate", and also after the end of the session. The metrics defined in [26] include:

- Corruption duration metric.
- Successive loss of RTP packets
- Frame rate
- Jitter.
- Sync loss duration.
- Average codec bit rate
- Codec information.
- Call setup time.

However, the specified metrics don't include energy consumption related information.

7.7.3 Procedures

This Candidate Solution proposes a new metric; procedures for reporting this metric from the UE to an external entity are described in solution #4 in clause 7.5.

7.7.3.1 Network-triggered QoE configuration

7.7.3.1.1 Introduction

QoE Measurement Collection (QMC) functionality can be reused according to one of the two following procedures.

7.7.3.1.2 Option 1: Adding Energy Consumption as a new flag in MTSI QoE reporting, relating to a specific media delivery session

The following signalling diagram is based on TS 26.114 [26] for MTSI use cases.

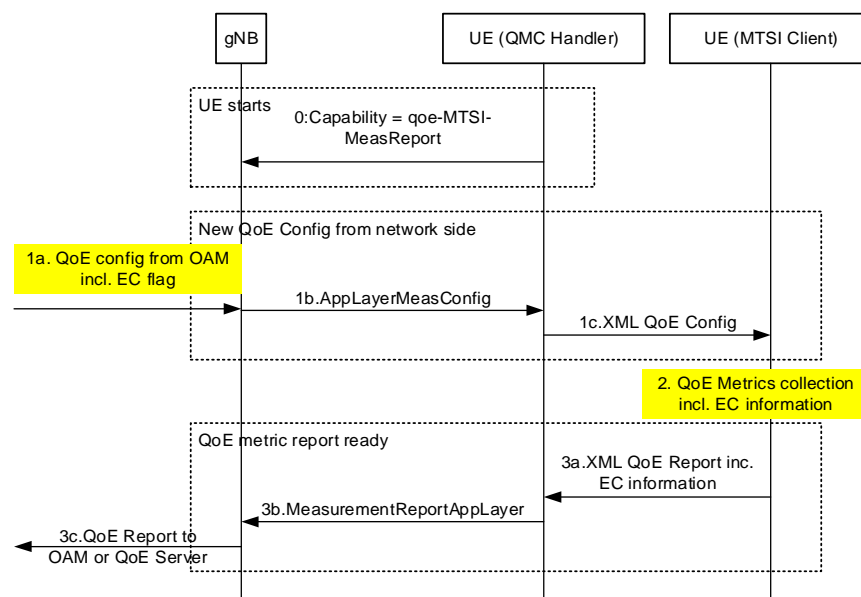

Figure 7.7.3.1.2-1: Example signalling diagram for Option 1

The steps are as follows:

- 0: When UE starts/registers, the QMC handler of the UE indicates *qoe-MeasReport* capability via UE Access Stratum when supported.
- 1a: The OAM sends QoE configuration requests with EC flag (energy consumption) inside MTSI QoE reporting request, which is associated with media session ID, time stamp, etc.
- 1b: The gNodeB triggers the QMC handler with for QoE reporting to collect QoE metrics.
- 1c: The QMC Handler within the UE triggers the MTSI Client to collect MTSI QoE metrics;
- 2: The MTSI Client in the UE collects Energy-related QoE metrics related to the media session. This may be done e.g. based on new AT commands between the UE Application Layer and the UE Access Stratum.
The UE may rely on the Energy Information Collector defined in Solution #5, including via the QMC handler entity.
- 3: A new QoE report is created and sent to OAM via QMC Handler, including the requested EC information in the MTSI QoE container.
- 3c: After the OAM has received UE energy consumption status report, the OAM may forward this information to an MnS Consumer (e.g. AF), the AF can accordingly propose an optimized network configuration (e.g. different QoS) or slice to the UE via the 5GC to fit the UE energy consumption status.

7.7.3.1.3 Option 2: Dedicated QoE configuration for energy reporting only

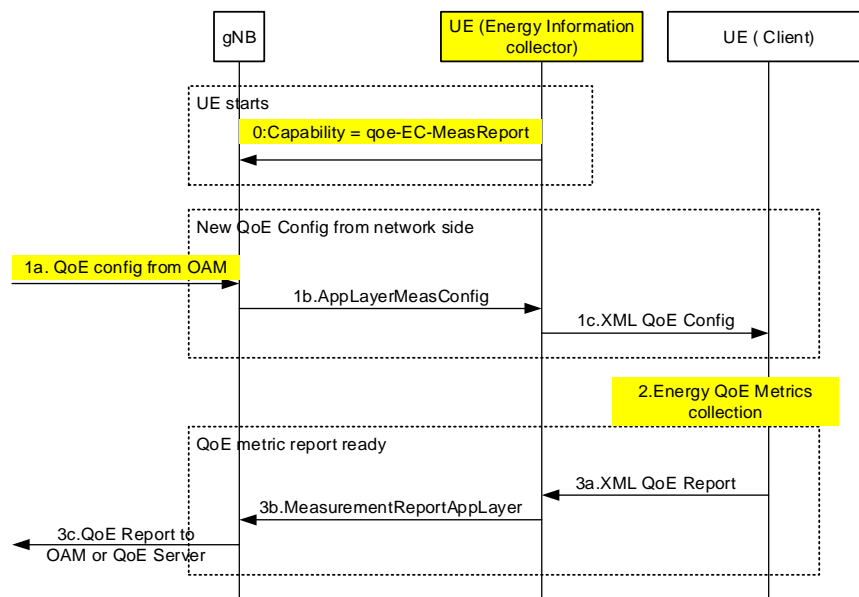

Figure 7.7.3.1.3-1: Example signalling diagram for option 2

The steps are as follows:

- 0: The UE indicates to the gNodeB that it supports energy consumption measurement via *capability = qoe-EC-MeasReport*.
- 1a: The OAM requests energy consumption reporting via a dedicated QoE configuration request *qoe-EC-MeasReport*.
- 1c: The Energy Information Collector in the UE forwards this request to the client.
- 2: The client in the UE collects QoE metrics including the requested EC information and creates the new QoE report.
- 3: The UE sends the QoE report (periodically) to the OAM via UE (Energy Information Collector) with the requested EC information.
- 3c: After the OAM has received a UE QoE status report, the OAM may forward this information to an MnS Consumer (e.g. AF), the AF can accordingly propose an optimized network configuration (e.g. different QoS) or slice to the UE via the 5GC to fit the UE energy consumption status.

The same mechanisms apply to DASH and XR use cases using QMC: similarly to MTSI, the Energy Consumption information mentioned above can be incorporated into the *qoe-Streaming-MeasReport* QoE configuration request and reported using QMC.

7.7.4 Summary

This candidate solution introduces:

1. New QoE metrics related to UE Energy Consumption by the UE, along with processing at the application level, which can be associated with a dedicated media session.
2. UE-side configuration to optimize user experience based on the collected energy and media session QoE-related metrics, including requesting the network or AF to optimise the session or split-rendering support.
3. Network-triggered mechanisms for configuration and reporting of UE energy metrics, either inside or outside the scope of QoE metrics collection for a particular media delivery session, as well as RAN-visible QoE reporting of UE energy consumption information.

The proposed solution involves coordinating with RAN and OAM since the solution involves sending information from the UE application to the OAM via gNodeB.

7.8 Solution #7: Energy Information Exposure Specification for controlling exposure of Energy-related information to Application Service Provider

7.8.1 Key Issue mapping

This solution addresses Key Issue #1 (Energy-related Information exposure) described in clause 6.1.

7.8.2 Functional description

An Energy Information Exposure Specification represents the configuration of the energy-related information required to be exposed to a particular Application Service Provider. This Candidate Solution is intended to be used in combination with other Candidate Solutions that expose this information, including Solution #4 in clause 7.5 and Solution #5 in clause 7.6.

Definition of the Energy Information Exposure Specification is for further study. For example, a mode of energy exposing (i.e. energy efficiency, energy consumption, power consumption or carbon emission), an exposing granularity, an exposing level (i.e. Media Delivery session, service component), an exposing time dimension, etc.

7.8.3 Procedures

Procedures for handling Energy Information Exposure Specification are proposed in clause 7.6.3.

7.9 Solution #8: UE application energy consumption measurement based on MTD technique

7.9.1 Key Issue mapping

This Candidate Solution addresses Key Issue #2.

7.9.2 Functional description

7.9.2.1 Introduction

Month-till-Date or Month-to-Date (MTD) is a practical and popular method for performance tracking and analysis since it can be applied to a wide range of metrics and performance indicators. It gives information about how a particular statistic has fared this month in comparison to past months or predetermined goals. It is a widely used concept across different domains for tracking, reporting, and evaluating various metrics and performance indicators within the current month up to the present date [84].

With MTD, a metric's performance is evaluated from the beginning of the current month to the present, taking into account key performance indicators (KPIs). It is usually computed daily and gives an instantaneous picture of performance for the entire month so far.

The monthly total MTD is determined by adding the metrics' values from the first of the month to the present. For instance, adding up the daily battery consumption for a particular application from the first of the month to the current date would yield the total MTD energy consumption of the application.

7.9.2.2 Calculation of MTD

7.9.2.2.1 High-level description

At a very high level, calculating an MTD metric involves determining the period from the beginning of the current month up to the present date. It is calculated as follows:

1. *Identify the current date:* Determine today's date, the end point of the MTD calculation.
2. *Identify the start of the month:* Find the first day of the current month. For example, if today is July 15th, the start of the month would be July 1st.
3. *Count the number of days:* Calculate the number of days from the start of the month up to the current date, including today.

To accurately measure the average battery consumption of MTD on UE devices, battery tests should be conducted over a 24-hour period. This ensures the readings account for typical device usage and provide reliable results.

7.9.2.2.2 UE battery consumption calculation

The energy consumed by a UE application can be expressed as an MTD metric. The percentage of total battery consumed by the application in a particular session is calculated using the following formula:

$$\% \text{ MTD}_{app1,UE} = \frac{\text{Total battery consumed by the app in a session} * 100}{\sum_{i=power\ state} \text{Total battery capacity of the device} (i)}$$

In the example depicted graphically in figure 7.9.2.2.2-1 below, the total battery consumed is 0.051% of the total battery capacity of a Google Pixel 6 Pro smartphone with total battery capacity of 5003 mAh. The points on the graph show the cumulative battery consumption by the app till a particular time since the start of the session. In this example, the application has consumed a total of 1.03 mAh battery during the first 34.49 seconds of the session. The axes represent the following:

- X-axis: Depicts the time (in seconds) elapsed since the start of the session. 0 on the X-axis represents the start of the energy profiling session.
- Y-axis: Depicts the cumulative battery energy consumed by the application (in mAh) up to a particular point in time since the start of the energy profiling session. The Y-axis starts with 0 mAh.

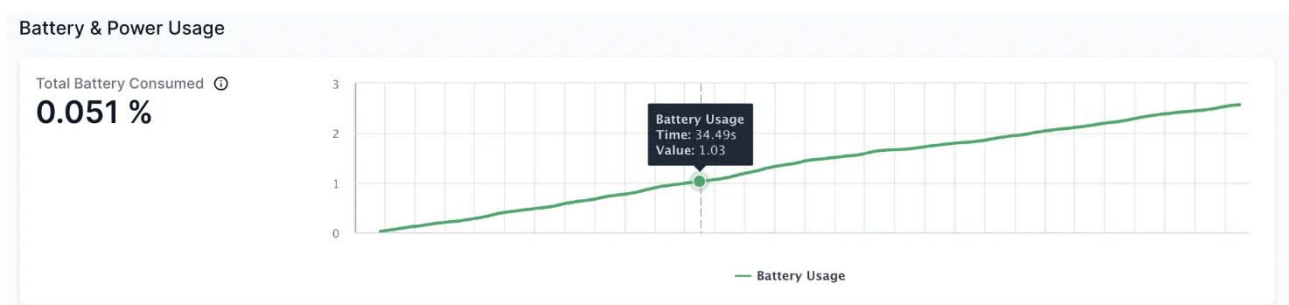

Figure 7.9.2.2.2-1: Example of energy consumed by an application running on a smartphone

The actual MTD battery consumption is determined by subtracting the battery end percentage from the battery start percentage, and multiplying it by the percentage of consumption of the application (expressed as a decimal). From this, the mean average percentage consumed per hour can then be derived by dividing the actual consumption by 24.

To determine actual MTD battery consumption, the following formula can be used:

$$\text{True Consumption (of app 1)} = (\text{Battery Start \%} - \text{Battery End \%}) \times (\text{MTD Consumption \%} / 10)$$

To calculate the percentage of battery used per hour:

$$\text{Battery Usage Per Hour (of app 1)} = \text{True Consumption} / 24$$



Figure 7.9.2.2.2-2: Example input data for MTD calculation

Based on the data provided in the figure 7.9.2.2.2-2 above, the calculation for MTD battery consumption is as follows:

- Device battery consumption since last charge = 93% – 78% = 15%
- MTD battery usage = 76% / 10 = 7.6
- True battery consumption = 15% × 7.6 = 114%
- Battery Usage by MTD per hour = 114% / 24 hours = 4.75% per hour

7.9.3 Procedures

The procedures for reporting this metric from the UE to an external entity are described in Solution #4 in clause 7.5.

7.9.4 Summary

This Candidate Solution proposes a new metric that allows UE application energy consumption to be measured. It has the following limitations:

1. The solution evaluates the battery consumption of individual applications executing on a UE, while other energy consuming aspects such as radio transmissions (4G, 5G, Wi-Fi), etc. may have additional impact on the total battery consumption of the UE.
2. The solution is UE implementation-specific, i.e. the same feature may result in different evaluations of battery consumption of the same application running on different UEs.
3. The solution may result in different evaluations of battery consumption of the same UE depending upon the test conditions that may vary over time (e.g. environmental changes and radio conditions, etc.).

7.10 Solution #9: UE energy metrics abstraction

7.10.1 Key Issue mapping

This Candidate Solution addresses Key Issue #1.

7.10.2 Functional description

7.10.2.1 Introduction

Clause 6.15A.5 of TS 22.261 [5] defines information exposure, which clearly states that information related to energy consumption and efficiency is not only necessary for network internal optimization, but also will benefit the service adjustment for third parties such as Application Service Providers. This Candidate Solution to Key Issue #1 determines the method of obtaining this additional energy information with the objective of measuring the effects of service adjustments on a single UE at a time. A summary is provided of energy information relevant to the UE that can be exposed by the UE to external entities in an abstract way, without exposing any internal information relating to the UE.

7.10.2.2 Energy-related information relevant to the UE

Table 7.10.2.2-1 lists several device properties which are UE energy information. Alongside the entries defined by the *deviceCapabilities* object in table 8.4.2.2-1 of TS 26.565 [65], these may be useful in calculating a consolidated UE energy metric.

Table 7.10.2.2-1: UE-related energy information

Property	Description
UE battery life	Level of the battery of the UE (e.g. in %). Based on an estimate of how long the battery will power the device on a single charge. In simple terms, it indicates how long the device can run before needing a recharge which, depending on usage, can be a matter of hours or an entire day.
UE energy consumption (EC)	UE charging/discharging rate (e.g. in Watt-hours, negative or positive). Calculated as the integral of power consumption over time as defined in TS 28.310 [2].
UE energy saving duration preference	Remaining time during which the UE wants to be considered in energy saving (e.g. in minutes).
UE battery capacity	The total UE battery capacity (e.g. in mAh). The total amount of electricity generated due to electrochemical reactions in the battery and is expressed in ampere hours. For example, a constant discharge current of 1 C (5 A) can be drawn from a 5 Ah battery for 1 hour [86].
UE source of power supply	e.g. "battery", "plugged in". Indicates whether the UE is currently operating on battery or is plugged in to an external power supply, which may or may not be renewable energy (e.g., solar panel). This could include the ratio of renewable energy over different time granularities (e.g. plugged in 30% renewable over the last 24 hours as described in TS 28.310 [2]).
UE battery discharge rate	e.g. between 0 and 1000. Calculated as the battery capacity (in mAh) divided by the number of hours it takes to /discharge the battery. For example, a battery capacity of 500 Ah that is theoretically discharged to its cut-off voltage in 20 hours will have a discharge rate of 500 mAh/20 h = 25 mA [86].
UE measurement duration	Energy Measurement time interval.
UE carbon intensity	In $g\ CO_2-e/Wh$. A measure of the global greenhouse gases emitted per unit of generated electricity, measured in grams of CO ₂ equivalents per watt-hour (for conversion to carbon emissions as defined in TS 22.261 [5] and TS 23.700-66 [20]).

7.10.2.3 Estimating the energy usage of media applications running on the UE

The Accubattery application [87] is an example, where we can understand that it allows the user to visualise the battery usage of each individual application installed on an Android UE, as illustrated in figure 7.10.2.3-1 below.



Figure 7.10.2.3-1: Example of UE application showing per-application battery consumption (source: [87])

Similar techniques could be used to determine the battery consumption of individual media applications as input to the calculation of the UE energy-related information index.

NOTE: Further study is needed to identify the UE APIs used to obtain per-application battery consumption information on different UE operating systems.

7.10.2.4 UE energy information index abstraction

UE energy information is private UE information, and it is possible that UE manufacturers/chipset vendors do not want to share this raw information with third parties, network operators or with the Application Service Provider. Hence, this Candidate Solution proposes a method which allows to deduce an abstract UE energy information based on internal UE energy related characteristics such as its battery capacity, battery discharge rate, etc. This calculation and implementation of the UE energy index is left to individual UE manufacturers and/or chipset vendors. But this index value is abstracted such that it does not reveal any internal properties of the UE such as its battery capacity, battery discharge rate, etc, when this information needs to be shared with external parties such as network services providers, content providers, etc.

As per the definition in clause 3.1 of the present document, *UE Energy Information* refers to energy-related information collected by the UE. Some examples are shown in table 7.10.2.2-1. This abstract value of the UE energy-related information is an integer index value corresponding to a particular UE battery capacity, UE supply and UE energy consumption rate, etc. The index is, by design, a relative value which is not comparable with that calculated by another UE with similar energy capacity and energy supply, whether from the same or a different manufacturer.

For example, two UEs from the same manufacturer have 4000 mAh battery capacity. But the way that each of these UEs consume their energy (drain their batteries) is completely different for some or all of the following reasons, amongst others:

1. Different battery drain rate due to the age of each of the UEs. The older the UE's battery drains faster than that of the newer UE.
2. Different battery drain rate at different ambient temperature (e.g. 40°C versus -5°C) as a result of different electrical efficiency in the UE.
3. A premium flagship model might consume energy at a different rate than a basic model, even if both are using the same application under the same conditions.
4. Different user behaviours that result in different energy consumption.

The set of criteria used to calculate the index value for UE could be extended to take additional criteria into account, such as the energy usage of individual applications as described in clause 7.2.2.3.

In summary, the UE energy information abstraction is unique to each UE, which allows the energy consumption rate using a particular energy supply to be identified. How such a value is derived is implementation-specific: it is left to each UE manufacturer to implement specific methods to derive this value, taking into consideration the energy capacity, energy supply and energy consumption rate of each individual UE model. This unique index value does not reveal any direct information about how a UE consumes its energy, allowing only an abstract value to be exposed beyond the UE. Hence, this information is unique to every UE and cannot meaningfully be compared with that provided by any other UE.

Because of this abstraction, any external entity (e.g., a Network Function) receiving this information is not aware of which UE (device type, model, battery capacity, etc.) has exposed that value. Rather, it is only aware of the corresponding energy consumption of a particular device (running a particular application).

7.10.3 Procedures

This Candidate Solution proposes a new metric; procedures for reporting this metric from the UE to an external entity are described in solution #4 in clause 7.5.

7.10.4 Summary

This Candidate Solution describes an abstract UE energy information index as described under clause 7.10.2.4. This index is an integer value that does not reveal information about the UE that can be fingerprinted. In addition, the energy index is a relative value which is unique to an individual UE and is not comparable with values calculated for any other UE, even if both UEs are identical (e.g. from the same manufacturer, the same model with the same battery capacity and similar characteristics, etc.) for the reasons mentioned in clause 7.10.2.4.

- This Candidate Solution describes an abstract UE energy information index, which represents the energy consumed by the UE of a particular 3GPP service during a media session via the 5G system.

- This Candidate Solution does not propose any standardised methodology for the calculation of the proposed energy index value. Hence, the proposed methodology is limited by the lack of a standardised way to implement the calculation of the UE energy-related information index value.
- It is intentionally left to the discretion of the UE manufacturer/chipset vendors to determine the most appropriate and most accurate method to calculate the index value depending upon individual UE characteristics.
- The only requirement is that more energy-intensive activities on the UE are reflected in a higher index value (which is a higher integer value).
- The proposed Candidate Solution has several limitations and cannot be implemented. Some examples include: how to calculate the energy consumption information of the individual hardware/software components (such as decoders/encoders) that are involved within the UE during a media streaming session, how to calculate the energy consumption information of the renderers that are used in the media session, etc.

Further study would be needed to determine the exact APIs available to interrogate energy-related information on the UE, and to assess the accuracy of the information they expose to the API invoker. There is no intent to specify this UE energy information index normatively in 3GPP specifications.

8 Conclusions

8.1 General

The present document highlights ongoing challenges in accurately estimating and reporting energy consumption of media delivery in the 5G System, including mobile network as well as end-user devices. The main difficulties are:

- *Data accuracy*: Difficulty in obtaining precise power data at the hardware level and in reporting these data preserving privacy.
- *Energy attribution*: Challenges in assigning energy usage to specific data throughput across multiple stakeholders as expected by regulators and protocols, complicated by non-linear relationships between energy and data.
- *Regulatory pressures*: Legal requirements for net zero emissions necessitate clear energy allocation strategies, which can lead to disputes among network operators, service providers and consumers.
- *Measurement boundaries*: Defining system boundaries for energy measurements affects responsibility and accountability.

Current assessments of energy use are often too coarse for effective policymaking or system design, and do not meet reporting standards set by the Greenhouse Gas Protocol (see clause 4.2.5) and regulatory bodies (see, for example, clause 4.2.8). The present document suggests that collecting fine-grained energy consumption data in real time could address these challenges and proposes a framework for future measurements.

8.2 Conclusion for Key Issue #1 (Energy-related information exposure)

Five alternative Candidate Solutions addressing this Key Issue are documented:

- Solution #4 in clause 7.5 proposes to extend the UE data collection, reporting and event exposure architecture defined in TS 26.531 [21] such that the Direct Data Collection Client additionally collects and reports per-application UE energy-related information to the Data Collection AF.
- Solution #5 in clause 7.6 proposes a new architecture and related procedures allowing energy-related information from the device and the network (including the AS) to be provided to a UE application during media consumption for exposure to the user with the definition of two new components, the *Energy Information AF* and the *Energy Information Collector*.
- Solution #6 in clause 7.7 proposes to extend the MTSI UE QoE reporting mechanism with energy-related information

- Solution #7 in clause 7.8 proposes an Energy Information Exposure Specification which represents the configuration of the Energy Information required to be exposed to a particular Application Service Provider.
- Solution #9 in clause 7.10 describes an abstract UE energy-related information index. This information is abstracted such that it does not reveal any internal properties of the UE such as its battery capacity, battery discharge rate, etc.

The following aspects are concluded:

- For exposure of end-to-end energy-related information to the network, the Direct Data Collection Client and Data Collection AF specified in TS 26.532 [22] or MTSI UE QoE reporting specified in TS 26.114 [26] would need to be extended to take into consideration UE energy-related information in addition of their existing data.
- For exposure of end-to-end energy-related information to UE applications, two new entities and their associated interfaces would be required to provide energy-related information from the device, the network and other components of the Media Delivery system to a UE application: The Energy Information AF and the Energy Information Collector.
- Definition of the Energy Information Exposure Specification is for further study.
- No normative work is planned on the abstract UE energy-related information index.

There is consensus to address the above principles by the following normative work:

1. Create a new stage-2 TS defining an energy architecture with the definition of two new entities, the Energy Information AF and the Energy Information Collector, using energy information available on Energy Information Function (EIF) allowing end-to-end energy-related information to be exposed to UE applications.
2. Extend TS 26.501 [23] and TS 26.506 [59] to instantiate the above architecture in the media context.
3. Address the relevant stage-3 aspects based on stage-2 work.

No consensus has been found on UE energy information exposed to the network. Hence, it is not recommended to pursue Solution #4 in clause 7.5 and Solution #6 in clause 7.7 with normative work.

8.3 Conclusion for Key Issue #2 (Energy-related monitoring and measurement)

Three solutions addressing this Key Issue are documented:

- Solution #3 in clause 7.4 describes how UE Operating Systems provide tools to assess the energy footprint of applications using system-wide metrics but lists some major limitations (information not publicly available on all UE OS, not limited to media consumption and with uncertain accuracy).
- Solution #6 in clause 7.7 proposes a method leveraging energy consumption information to monitor and measure the way the media content is handled and delivered to the users, and to provide better Quality of Experience (QoE) for users.
- Solution #8 in clause 7.9 proposes a new metric that allows to measure UE application energy consumption.

The following aspects are concluded:

- On the device side, there is no consensus on defining a UE entity in the 5G System to manage the measurement of UE energy-related information. UE energy-related information can still be used on some UE Operating Systems providing these kinds of metrics, but because the metrics differ from one UE OS to another, there will not be normative work on UE energy-related information collection and metrics. A metric allowing UE application measurement thanks to MTD (Month-till-Date or Month-to-Date) is available, but its limitations (not including radio transmission, UE implementation-specifics and depending on conditions) make it seem not relevant for the scope of the study.
- On the network side, the Energy Information Function (EIF) is defined in TS 23.501 [72] to collect UE-related Energy Consumption information from Network Functions in the 5G Core, to calculate the Energy Consumption information at the granularity of UE, PDU Session and/or QoS Flow, and to expose the Energy Consumption

information to the authorized consumer NF(s) (AF/NEF or another 5G Core NF). No additional information has been identified at this time in the context of media delivery or consumption.

In conclusion, there is no consensus at this time to initiate normative work addressing this Key Issue.

8.4 Conclusion for Key Issue #3 (Evaluation framework)

Two different solutions addressing this Key Issue are documented:

- Solution #1 in clause 7.2, based on work done by the French regulator, indicates how APIs available on some UE Operating Systems can be used to evaluate the impact of the use of some technologies on energy efficiency on devices in a lab.
- Solution #2 in clause 7.3 proposes a method to evaluate the energy efficiency of the entire UE as a whole device, which is UE implementation-specific.

The following aspects are concluded:

- No methodology has yet been identified allowing evaluation of the energy usage/savings of multimedia standards features and proposals, following best practices from these earlier characterization frameworks. The main difficulties are the lack of common UE metrics related to media consumption available on all mobile Operating Systems, and the lack of implementation of 5G network entities allowing to provide energy-related information from the network with sufficiently fine granularity.
- It seems that Energy Information Function implementations are needed before being able to evaluate the energy usage/savings of a multimedia standards feature on a specific device in a lab.

In conclusion, there is no consensus at this time to initiate normative work addressing this Key Issue.

9 Proposed next steps

The current conclusions of the present document recommend normative work addressing Key Issue #1 (Energy-related information exposure). This normative work is based on the new availability in the 5G System of the Energy Information Function (EIF) as defined in TS 23.501 [72] as well as the definition of two new entities, the Energy Information AF and the Energy Information Collector. Because the capabilities and interfaces of the Energy Information Function (EIF) are not yet fully defined, it seems premature to initiate a new normative Work Item addressing Key Issue #1 before the full definition of the EIF is available.

This study also raised several questions not addressed by any of the Key Issues already defined. For example:

1. How does an Application Service Provider provisions an Information Exposure Specification in the Energy Information AF?
 - Interaction with the PCF and/or the EIF may be required.
2. Is the concept of an Energy Policy needed to allow Application Service Provider to specify how the 5GMS System should react to energy-related information about its services shared with the Energy Information AF instantiated in 5GMS AF?
3. How might the 5GMS AS and/or the 5GMS Client (and equivalent functions of the RTC System) react to energy-related information shared with them by the network via the Energy Information AF instantiated in the 5GMS AF and/or the Energy Information Collector?
 - This could involve notification from and/or renegotiation with the PCF, potentially influenced by the Energy Policy mentioned above.
 - It could also involve modifications to the behaviour of the 5GMS AS and Media Stream Handler (downlink Media Player or uplink Media Streamer) and/or Dynamic Policy re-instantiation by the Media Session Handler.

A second phase of study seems relevant to complement the work already done addressing the new questions above and providing more details on the use of new 5G System functions to provide energy-related information.

This second phase could also allow work done in TR 22.883 [85] – which was not available during the first study phase – to be addressed, listing new use cases and potential requirements on the following aspects regarding enhancements on energy as service criteria:

- Information exposure of energy-related characteristics of the network for the communication service (i.e. energy consumption, energy supply mix, carbon footprint, energy capacity and availability conditions) to authorized users or authorized third parties.
- Potential dynamic adjustments of the delivered communication service from a 5G System perspective (including service performance adjustments) resulting from the changes of energy-related characteristics of this service. Dynamic adjustments can be based on criteria such as network decision, user preference or agreement between authorized third parties and the network.
- Other aspects including security, charging and privacy for the scenarios above.

The recommendation of the present document is to:

1. Wait for the full definition of the Energy Information Function (EIF) and the completion of TR 22.883 [85].
2. Then, update the present document with:
 - a. More details on the interaction with the Energy Information Function (EIF).
 - b. New Key Issues addressing questions not yet addressed.
 - c. New Key Issues addressing new relevant use cases and requirements defined in TR 22.883 [85].
3. Then, initiate normative work including:
 - a. Normative work already proposed for addressing Key Issue #1 (Energy-related information exposure) in clause 8.2.
 - b. Potential other work identified in the second phase of the study.

Annex A: Change history

Change history							
Date	Meeting	TDoc	CR	Rev	Cat	Subject/Comment	New version
2024-03	SA4#127-bis-e	S4-240565				TR skeleton	0.0.1
2024-04	SA4#127-bis-e	S4-240816				Addition of related work (S4-240803)	0.1.0
2024-05	SA4#128	S4-240875				Addition of Collection and exposure of energy consumption information by OAM (S4al240057)	0.1.1
2024-05	SA4#128	S4-241243				Addition of Description of the existing collection and exposure of energy consumption information at UE (S4-241212), Context information on greenhouse gas reporting laws, protocols and framework (S4-241218), Network energy use (S4-241220), UE energy consumption information reporting (S4-241224), KI#1 (S4-241228)	0.2.0
2024-08	SA4#129-e	S4-241409				Addition of Key Issue #2: Monitoring and measurement (S4al240112)	0.2.1
2024-08	SA4#129-e	S4-241736				Addition of Additional use cases defined by SA4 (S4-241718), related work in ITU-R (S4-241431), energy-related information amendment (S4-241432), Description of the existing collection and exposure of energy consumption information at NF (S4-241722) and KI#3 (S4-241732).	0.3.0
2024-10	SA4-e (AH) MBS SWG post 129e	S4al240172				Addition of Correction on collection and exposure at NF (S4al240173), Complements on KI#2 (S4al240142).	0.3.1
2024-10	SA4-e (AH) MBS SWG post 129e	S4al240174				Modification to description to Key Issue #1: Information exposure (S4al240126).	0.3.2
2024-11	SA4#130	S4-242087				Addition of Clause 3.1. Energy-related terms and definitions (S4-242067), Update to Clause 4.2.3.1 (S4-242068), Summary of energy efficiency standards from ETSI Environmental Engineering (EE) WG (S4-242069), Modification to description to Key Issue #2: Monitoring and measurement (S4-242070), Solution for KI3 based on French regulators study (S4-242109), Potential solution to Key Issue #3: Evaluation framework (S4-242164), KI2 solution based on existing UE energy-related information measurement (S4-242165).	0.4.0
2024-11	SA4#130	S4-242252				Editorial corrections.	0.4.1
2024-12	SA#106	SP-241756				Version created by MCC to send to TSG SA for information	1.0.0
2025-02	SA4#131	S4-250042				Addition of Potential solution to Key Issue #1: Energy-related information exposure from UE (S4al250007), Additional background information (S4al250018), Complements on KI3 (S4al250038), Potential solution to KI1 based Energy related information from the UE, network and other entities provided to an App (S4al250043), Abbreviations and introductions (S4al250048), Potential solution to Key Issue #2: QMC-based monitoring and measurement (S4al250066)	1.0.1
2025-02	SA4#131	S4-250246				Editorial corrections	1.0.2
2025-02	SA4#131	S4-250292				Addition of Text reference from French Agency for Ecological Transition (S4-250294), Text reference for Energy Information Function (S4-250293), potential solution to KI1 based Energy Information Exposure Specification to configure the exposure of the UE, network and other entities energy related information to the UE Application (S4-250150), Potential solution to Key Issue #2: UE application energy consumption measurement (S4-250299), Clarifications and additions to Solution #5 on exposure of energy related information (S4-250302), Proposed Conclusions (S4-250333), Potential solution to Key Issue #1: UE energy metrics abstraction (S4-250324).	1.1.0
2025-02	SA4#131	S4-250400				Track changes against version 1.0.0	1.1.1
2025-03	SA#107	SP-250286				Version 2.0.0 created by MCC	2.0.0
2025-03	SA#107					Version 19.0.0 created by MCC upon approval in TSG SA#107	19.0.0

History

Document history		
V19.0.0	January 2026	Publication