

ETSI TR 125 944 V3.0.0 (2000-03)

Technical Report

Universal Mobile Telecommunications System (UMTS); Technical Specification Group Radio Access Network; Channel coding and multiplexing examples (3G TR 25.944 version 3.0.0 Release 1999)



ReferenceDTR/TSGR-0125944U

KeywordsUMTS

ETSI

650 Route des Lucioles
F-06921 Sophia Antipolis Cedex - FRANCE

Tel.: +33 4 92 94 42 00 Fax: +33 4 93 65 47 16

Siret N° 348 623 562 00017 - NAF 742 C
Association à but non lucratif enregistrée à la
Sous-Préfecture de Grasse (06) N° 7803/88

Important notice

Individual copies of the present document can be downloaded from:

<http://www.etsi.org>

The present document may be made available in more than one electronic version or in print. In any case of existing or perceived difference in contents between such versions, the reference version is the Portable Document Format (PDF).

In case of dispute, the reference shall be the printing on ETSI printers of the PDF version kept on a specific network drive within ETSI Secretariat.

Users of the present document should be aware that the document may be subject to revision or change of status.

Information on the current status of this and other ETSI documents is available at <http://www.etsi.org/tb/status/>

If you find errors in the present document, send your comment to:

editor@etsi.fr

Copyright Notification

No part may be reproduced except as authorized by written permission.
The copyright and the foregoing restriction extend to reproduction in all media.

© European Telecommunications Standards Institute 2000.

All rights reserved.

Intellectual Property Rights

IPRs essential or potentially essential to the present document may have been declared to ETSI. The information pertaining to these essential IPRs, if any, is publicly available for **ETSI members and non-members**, and can be found in SR 000 314: "*Intellectual Property Rights (IPRs); Essential, or potentially Essential, IPRs notified to ETSI in respect of ETSI standards*", which is available from the ETSI Secretariat. Latest updates are available on the ETSI Web server (<http://www.etsi.org/ipr>).

Pursuant to the ETSI IPR Policy, no investigation, including IPR searches, has been carried out by ETSI. No guarantee can be given as to the existence of other IPRs not referenced in SR 000 314 (or the updates on the ETSI Web server) which are, or may be, or may become, essential to the present document.

Foreword

This Technical Report (TR) has been produced by the ETSI 3rd Generation Partnership Project (3GPP).

The present document may refer to technical specifications or reports using their 3GPP identities, UMTS identities or GSM identities. These should be interpreted as being references to the corresponding ETSI deliverables.

The cross reference between GSM, UMTS, 3GPP and ETSI identities can be found under www.etsi.org/key .

Contents

Foreword	4
1 Scope.....	5
2 References.....	5
3 Abbreviations.....	5
4 Channel coding and multiplexing examples	6
4.1 FDD mode	6
4.1.1 Downlink.....	6
4.1.1.1 BCH.....	6
4.1.1.2 Example for PCH and FACH	8
4.1.1.3 Example for DCH.....	9
4.1.1.3.1 DCH-> Radio frame segmentation	9
4.1.1.3.2 TrCH multiplexing -> Physical channel mapping	13
4.1.2 Uplink.....	18
4.1.2.1 Example for RACH.....	18
4.1.2.2 Example for DCH.....	19
4.1.2.2.1 DCH -> Radio frame segmentation	19
4.1.2.2.2 TrCH multiplexing -> Physical channel mapping.....	23
4.2 TDD mode	27
4.2.1 Downlink.....	27
4.2.1.1 BCH.....	27
4.2.1.2 Example for PCH	28
4.2.1.3 Example for FACH.....	29
4.2.1.4 Example for DCH.....	30
4.2.1.4.1 DCH-> Radio frame segmentation	30
4.2.1.4.2 TrCH multiplexing -> Physical channel mapping.....	35
4.2.2 Uplink.....	41
4.2.2.1 RACH.....	41
4.2.2.2 Example for DCH.....	42
4.2.2.2.1 DCH-> Radio frame segmentation	42
4.2.2.2.2 TrCH multiplexing -> Physical channel mapping.....	43
Annex A (informative): Change history.....	49

Foreword

This Technical Report (TR) has been produced by the 3rd Generation Partnership Project (3GPP).

The contents of the present document are subject to continuing work within the TSG and may change following formal TSG approval. Should the TSG modify the contents of the present document, it will be re-released by the TSG with an identifying change of release date and an increase in version number as follows:

Version x.y.z

where:

- x the first digit:
 - 1 presented to TSG for information;
 - 2 presented to TSG for approval;
 - 3 or greater indicates TSG approved document under change control.
- y the second digit is incremented for all changes of substance, i.e. technical enhancements, corrections, updates, etc.
- z the third digit is incremented when editorial only changes have been incorporated in the document.

1 Scope

The present document describes examples of channel coding and multiplexing for physical channels of FDD mode and TDD mode.

2 References

The following documents contain provisions which, through reference in this text, constitute provisions of the present document.

- References are either specific (identified by date of publication, edition number, version number, etc.) or non-specific.
- For a specific reference, subsequent revisions do not apply.
- For a non-specific reference, the latest version applies.

- [1] 3G TS 25.211: "Physical channels and mapping of transport channels onto physical channels (FDD)".
- [2] 3G TS 25.212: "Multiplexing and channel coding (FDD)".
- [3] 3G TS 25.213: "Spreading and modulation (FDD)".
- [4] 3G TS 25.214: "Physical layer procedures (FDD)".
- [5] 3G TS 25.215: "Physical layer – Measurements (FDD)".
- [6] 3G TS 25.221: "Physical channels and mapping of transport channels onto physical channels (TDD)".
- [7] 3G TS 25.222: "Multiplexing and channel coding (TDD)".
- [8] 3G TS 25.223: "Spreading and modulation (TDD)".
- [9] 3G TS 25.224: "Physical layer procedures (TDD)".
- [10] 3G TS 25.225: "Physical layer – Measurements (TDD)".

3 Abbreviations

For the purposes of the present document, the following abbreviations apply:

BCH	Broadcast Channel
CC	Convolutional coding
CCPCH	Common Control Physical Channel
CRC	Cyclic Redundancy Code
DCH	Dedicated Channel
DCCH	Dedicated Control Channel
DL	Downlink
DPCH	Dedicated Physical Channel
DPCCH	Dedicated Physical Control Channel
DPDCH	Dedicated Physical Data Channel
FACH	Forward Access Channel
FDD	Frequency Division Duplex
MA	Midamble
Mcps	Mega Chip Per Second
PCCPCH	Primary Common Control Physical Channel
PCH	Paging Channel

PRACH	Physical Random Access Channel
RACH	Random Access Channel
SF	Spreading Factor
SCCPCH	Secondary Common Control Physical Channel
TDD	Time Division Duplex
TFCI	Transport Format Combination Indicator
TPC	Transmit Power Control
TrBk	Transport Block
TrCh	Transport Channel
TTI	Transmission Time Interval
UL	Uplink

4 Channel coding and multiplexing examples

Following examples of channel coding and multiplexing is according to reference [2] and [7]. If there are any contradictions between following examples and the references, the present document should be corrected according to the references unless it is clear that the contradiction comes from error in the references.

Number and variables in following figures show the number of bits in corresponding fields.

4.1 FDD mode

4.1.1 Downlink

4.1.1.1 BCH

Table 1: Parameters for BCH

Transport block size	246
CRC	16 bits
Coding	CC, coding rate = 1/2
TTI	20 ms
The number of codes	1
SF	256

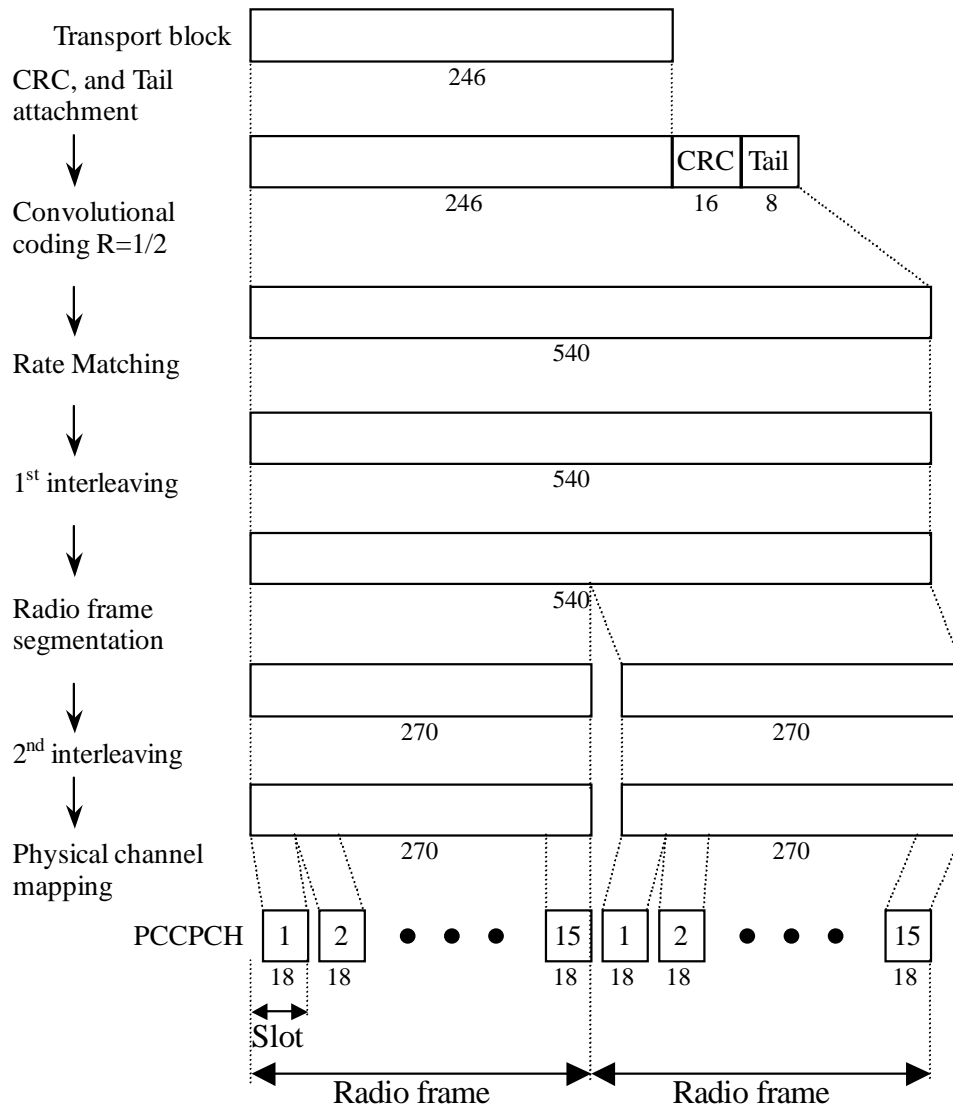

Figure 1: Channel coding for BCH

4.1.1.2 Example for PCH and FACH

Table 2: Parameter examples for PCH and FACH

Coding	CC, coding rate = 1/2
TTI	10 ms
The numbers of codes	1

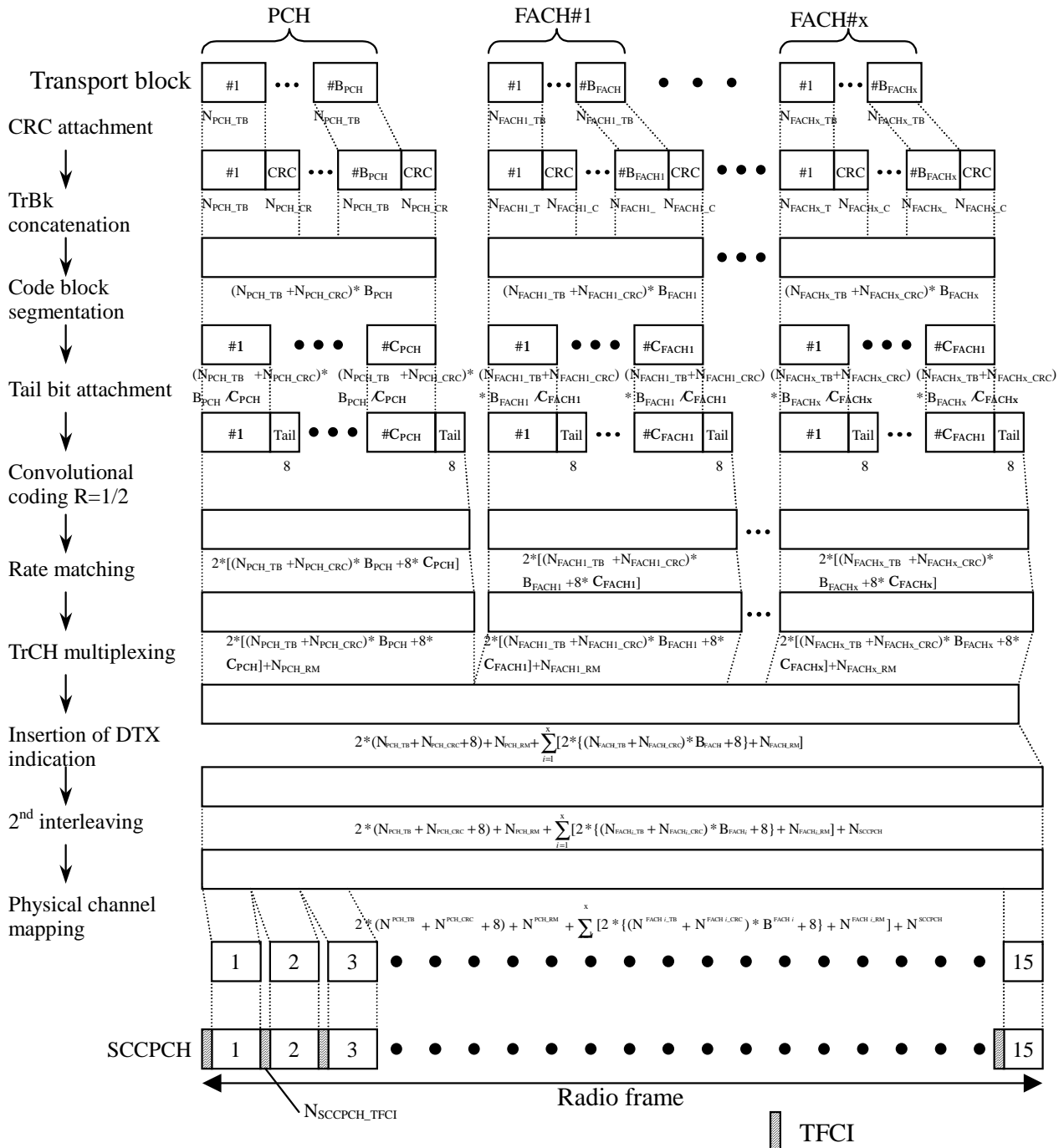

Figure 2: Channel coding and multiplexing example for PCH and FACH

4.1.1.3 Example for DCH

4.1.1.3.1 DCH-> Radio frame segmentation

4.1.1.3.1.1 Example for 4.1 kbps data

NOTE: This example can be applied to DCCH.

Table 3: Parameter examples for 4.1 kbps data

Transport block size	164 bits
Transport block set size	164 bits
CRC	16 bits
Coding	CC, coding rate = 1/3
TTI	40 ms

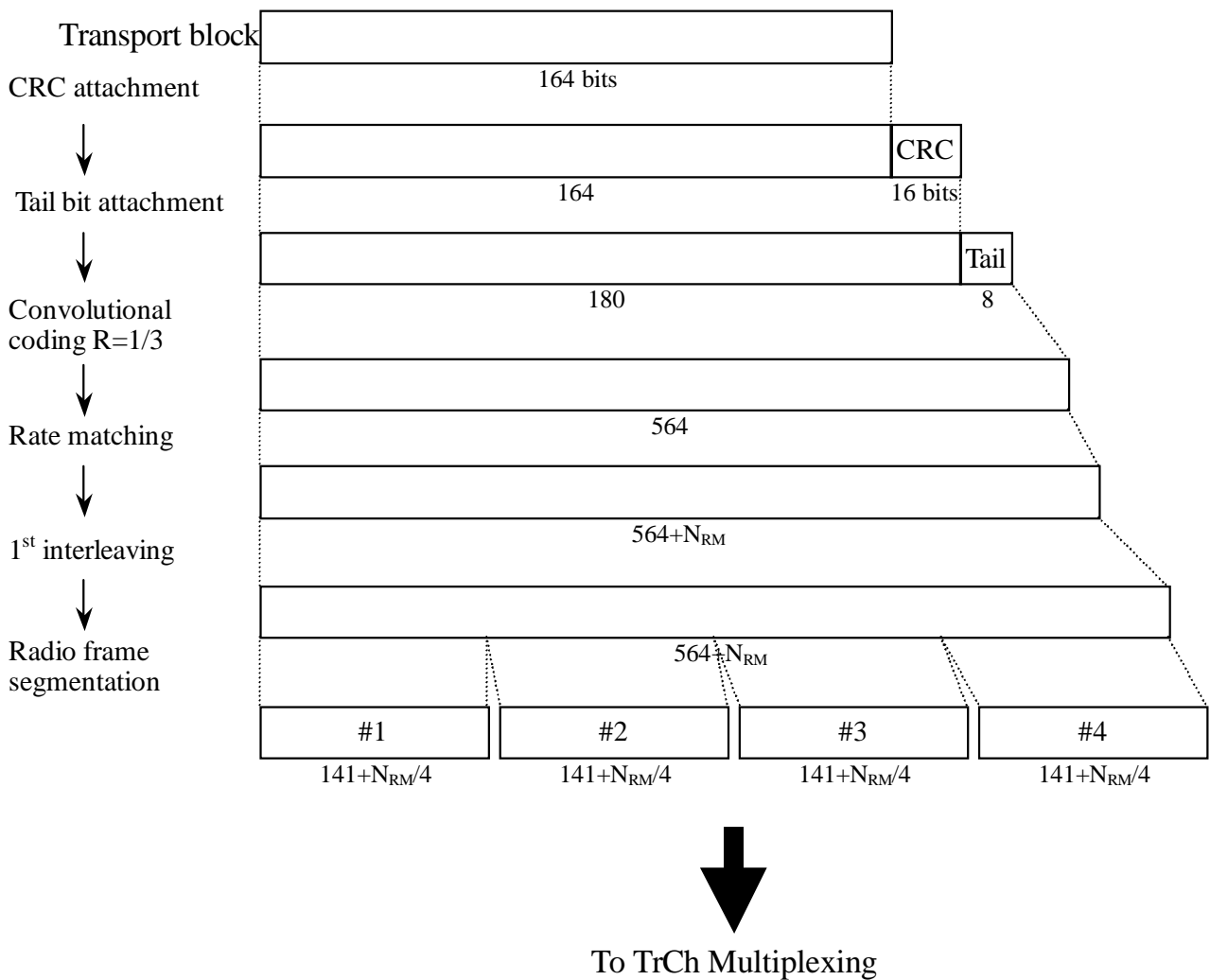

Figure 3: Channel coding and multiplexing example for 4.1 kbps data

4.1.1.3.1.2 Example for 12.2 kbps data

NOTE: This example can be applied to AMR speech.

Table 4: Parameter examples for 12.35 kbps data

The number of TrChs	3
Transport block size	81, 103, and 60 bits
CRC	12 bits (attached only to TrCh#1)
Coding	CC, coding rate = 1/3 for TrCh#1, 2 coding rate = 1/2 for TrCh#3
TTI	20 ms

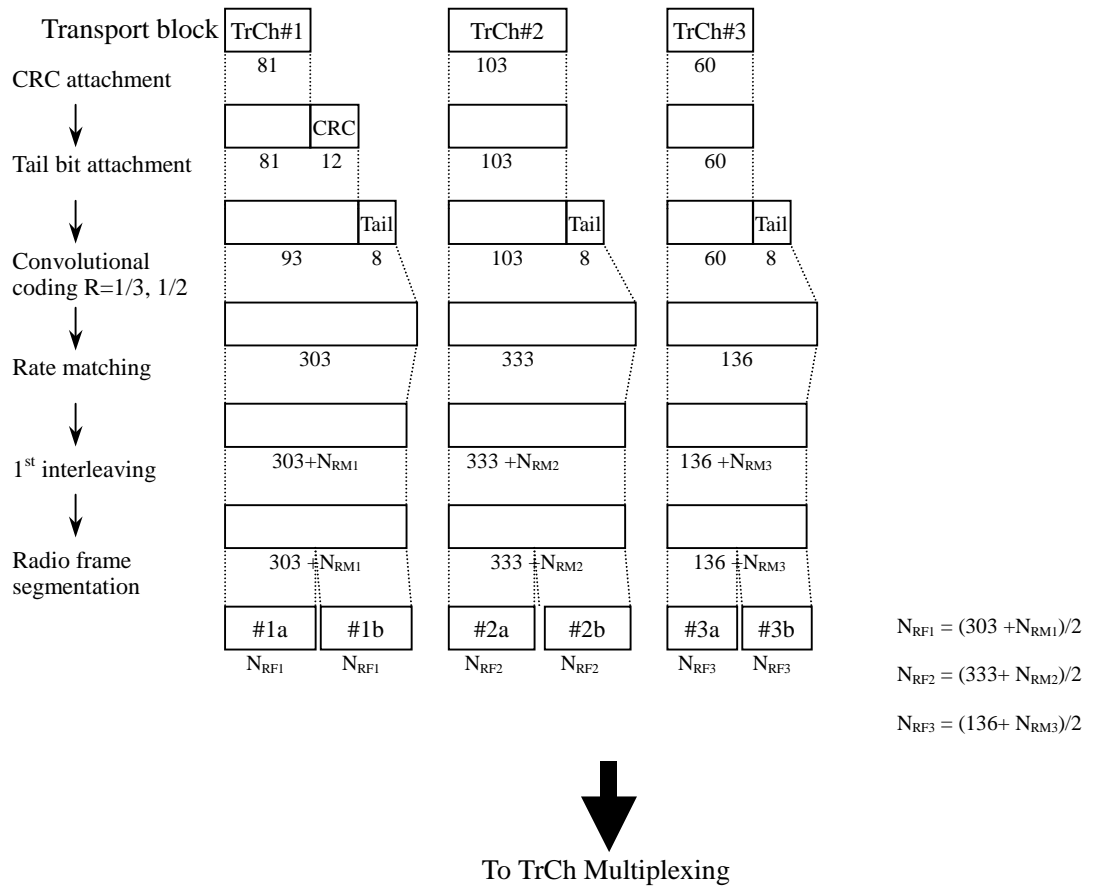

Figure 4: Channel coding and multiplexing example for 12.2 kbps data

4.1.1.3.1.3 Example for 64/128/384 kbps packet data

Table 5: Parameters for 64/128/384 kbps packet data

The number of TrChs		1
Transport block size		640 bits
Transport block	64 kbps	640*B bits (B = 0, 1)
Size size	128 kbps	640*B bits (B = 0, 1, 2)
	384 kbps	640*B bits (B = 0, 1, 2, ..., 6)
CRC		16 bits
Coding		Turbo coding, coding rate = 1/3
TTI		10 ms

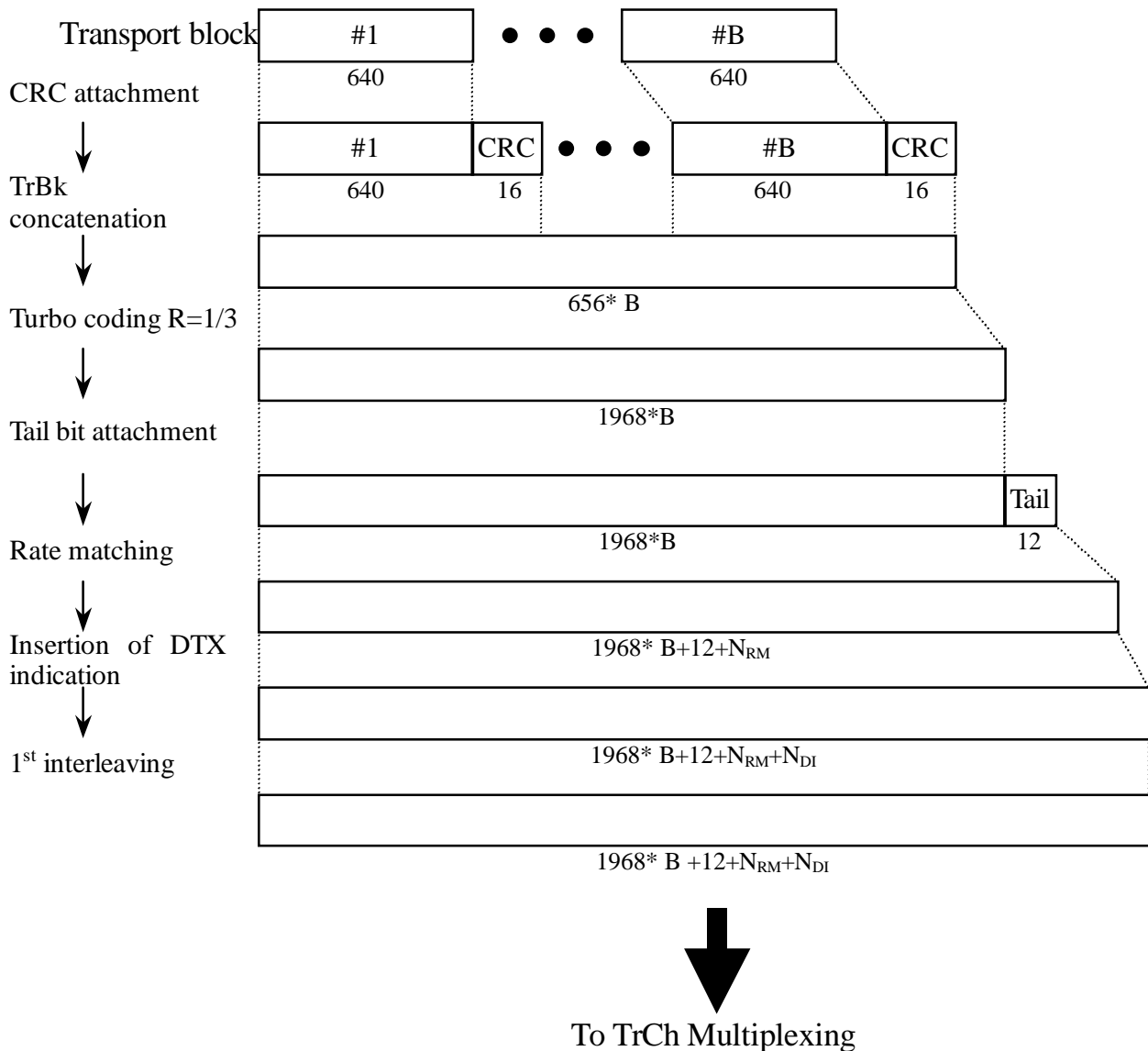

Figure 5: Channel coding and multiplexing example for 64/128/384 kbps packet data

4.1.1.3.1.4 Example for 64 kbps data

NOTE: This example can be applied to ISDN service.

Table 6: Parameters for 64 kbps data

The number of TrChs	1
Transport block size	640 bits
Transport block set size	4*640 bits
CRC	16 bits
Coding	Turbo coding, coding rate = 1/3
TTI	40 ms

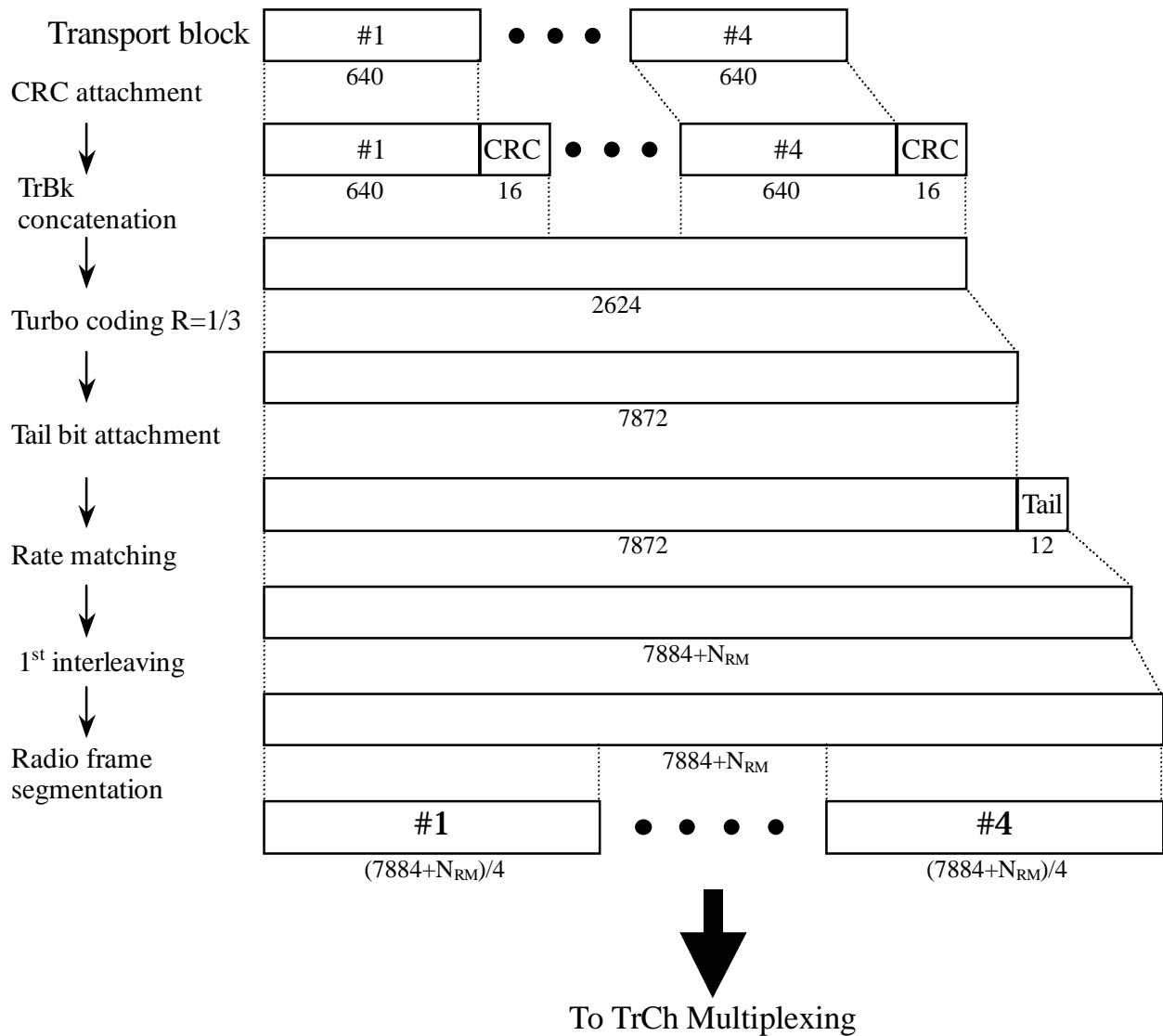

Figure 6: Channel coding and multiplexing example for 64 kbps data

4.1.1.3.2 TrCh multiplexing -> Physical channel mapping

4.1.1.3.2.1 Example for Stand-alone mapping of 4.1 kbps data

NOTE: This example can be applied to Stand-alone mapping of DCCH.

Table 7 shows example of physical channel parameters for stand-alone mapping of 4.1 kbps data.

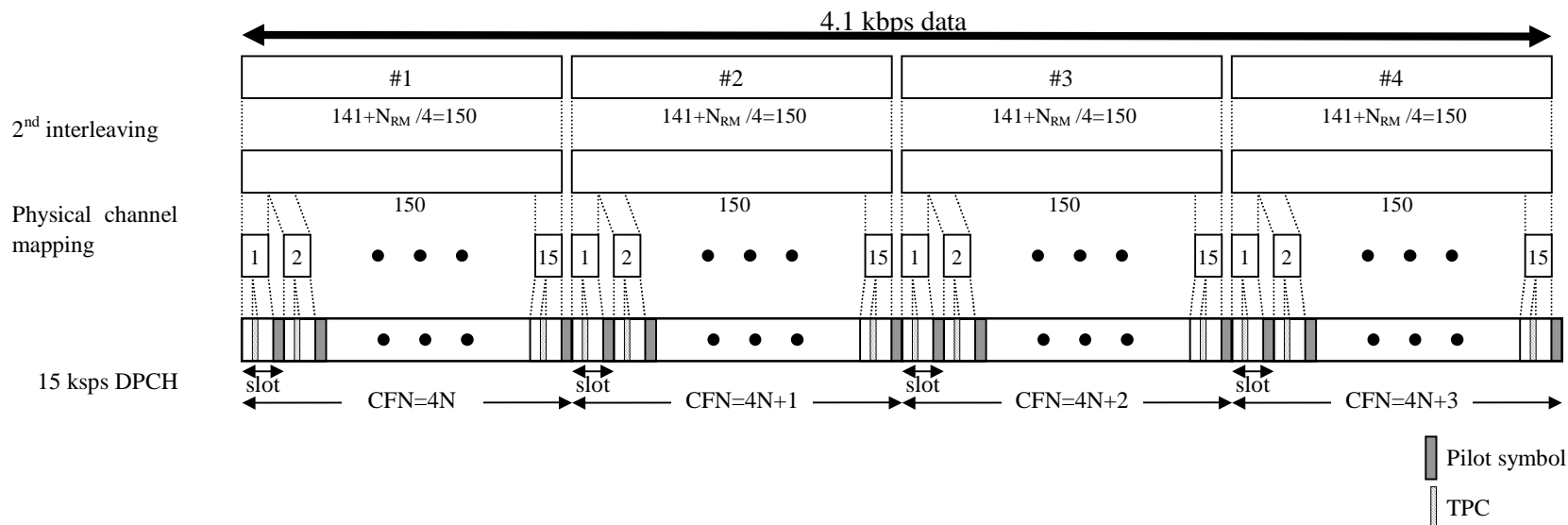

Figure 7: Channel coding and multiplexing example for stand-alone mapping of 4.1 kbps data

Table 7: Physical channel parameters for stand-alone mapping of 4.1 kbps data

Symbol rate (ksps)	N_{pilot} (bits)	N_{TFCI} (bits)	N_{TPC} (bits)	N_{data1} (bits)	N_{data2} (bits)
15	8	0	2	2	8

4.1.1.3.2.2 Example for multiplexing of 12.2 kbps data and 4.1 kbps data

NOTE: This example can be applied to multiplexing AMR speech and DCCH.

Table 8 shows example of physical channel parameters for multiplexing of 12.2 kbps data and 4.1 kbps data.

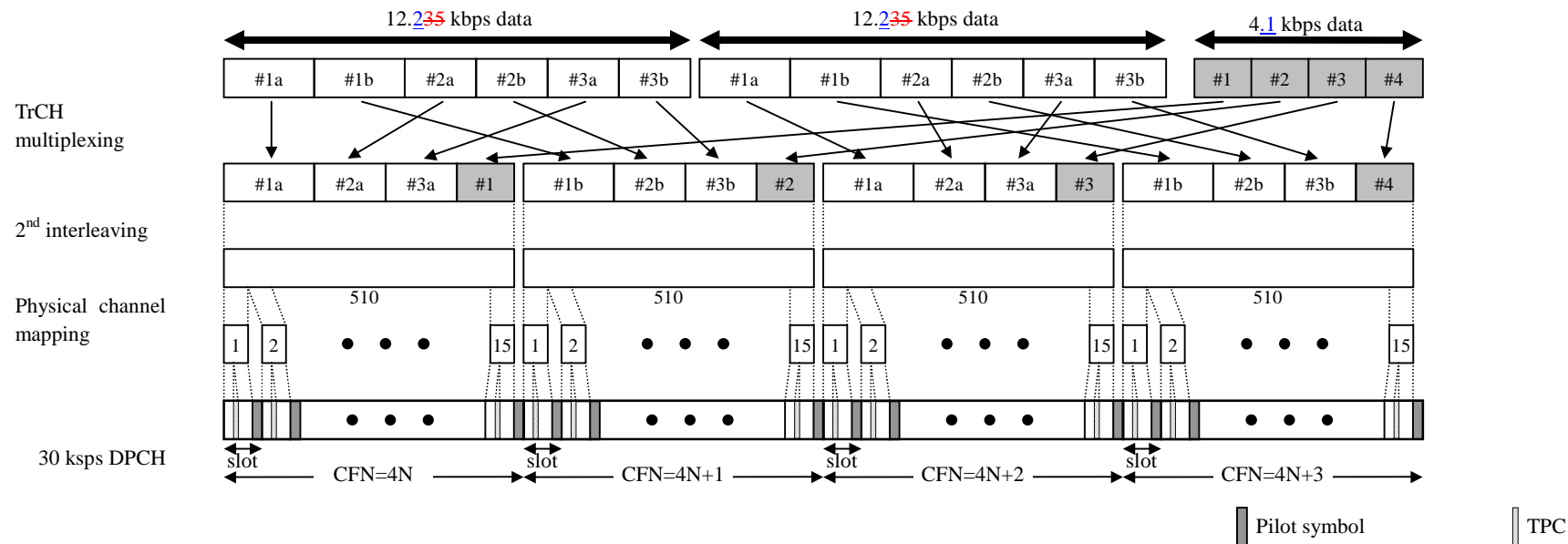

Figure 8: Channel coding and multiplexing example for multiplexing of 12.2 kbps data and 4.1 kbps data

Table 8: Physical channel parameters for multiplexing of 12.2 kbps data and 4.1 kbps data

Symbol rate (kps)	N _{pilot} (bits)	N _{TFCI} (bits)	N _{TPC} (bits)	N _{data1} (bits)	N _{data2} (bits)
30	4	0	2	6	28

4.1.1.3.2.3 Example for multiplexing of 64/128/384 kbps packet data and 4.1 kbps data

NOTE: This example can be applied to multiplexing 64/128/384 kbps packet data and DCCH.

Table 9 shows example of physical channel parameters for multiplexing of 64/128/384 kbps packet data and 4.1 kbps data.

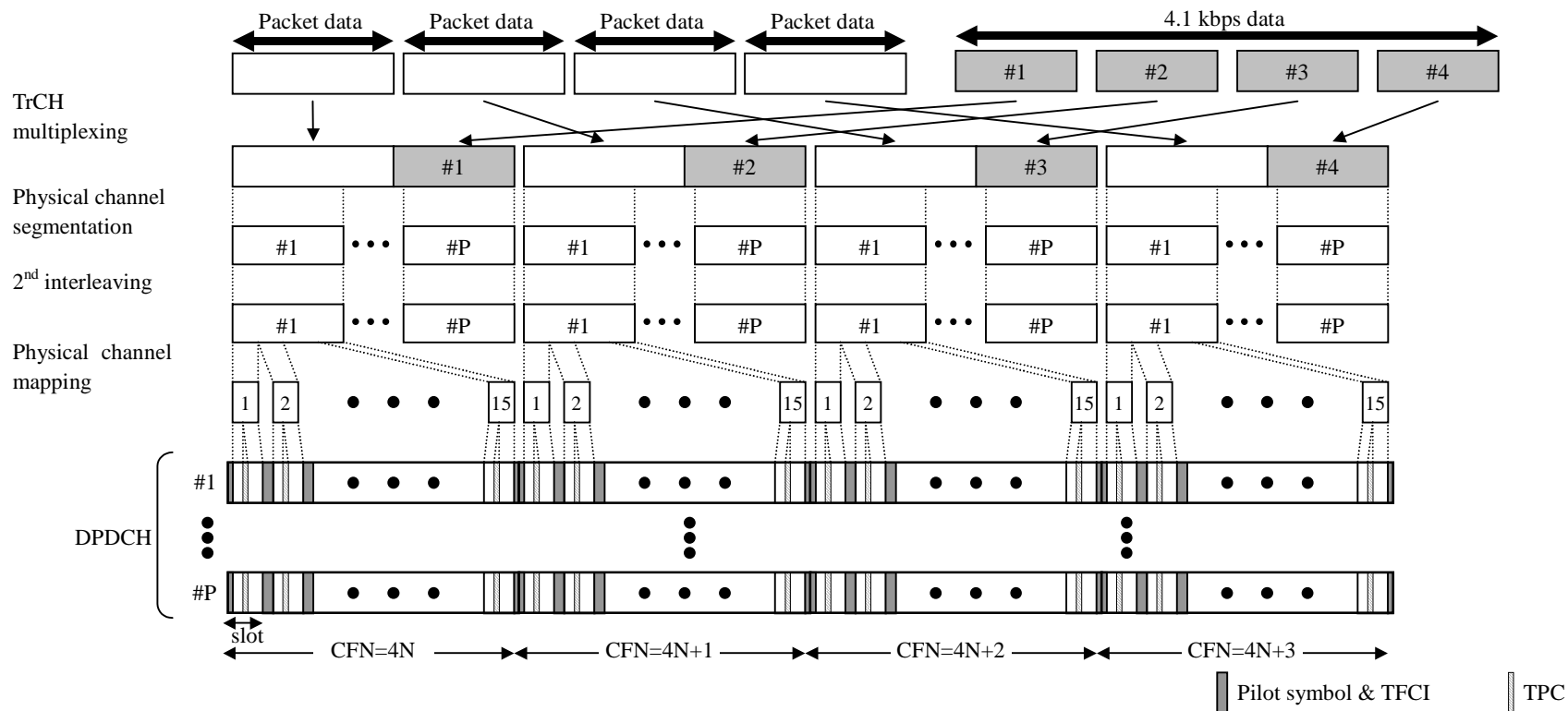

Figure 9: Channel coding and multiplexing example for multiplexing of 64/128/384 kbps packet data and 4.1 kbps data

Table 9: Physical channel parameters for multiplexing of 64/128/384 kbps packet data and 4.1 kbps data

Data rate (kbps)	Symbol rate (ksps)	No. of physical channel: P	N_{pilot} (bits)	N_{TFCI} (bits)	N_{TPC} (bits)	N_{data1} (bits)	N_{data2} (bits)
64	120	1	8	8	4	4	56
128	240	1	16	8	8	48	240
384	240	3	16	8	8	48	240

4.1.1.3.2.4 Example for multiplexing of 64 kbps data and 4.1 kbps data

NOTE: This example can be applied to multiplexing ISDNs data and DCCH.

Table 10 shows example of physical channel parameters for multiplexing of 64 kbps data and 4.1 kbps data.

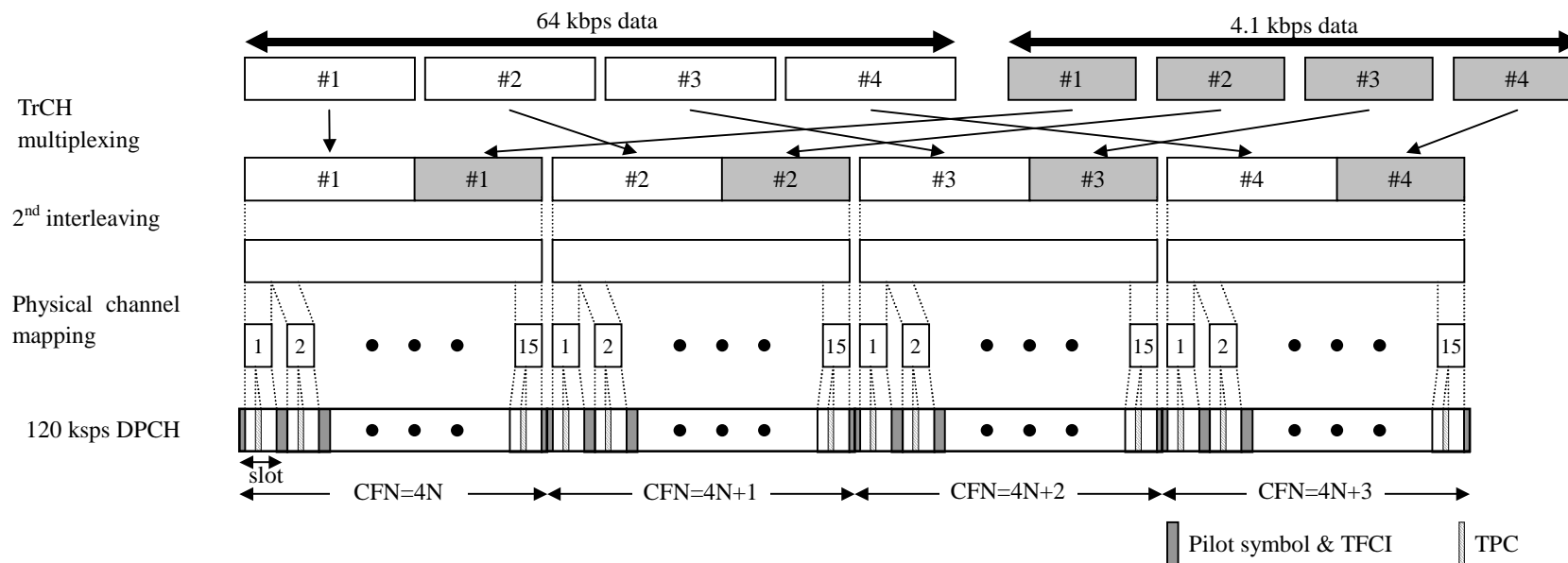

Figure 10: Channel coding and multiplexing example for multiplexing of 64 kbps data and 4.1 kbps data

Table 10: Physical channel parameters for multiplexing of 64 kbps data and 4.1 kbps data

Symbol rate (ksps)	No. of physical channel	N _{pilot} (bits)	N _{TFCI} (bits)	N _{TPC} (bits)	N _{data1} (bits)	N _{data2} (bits)
120	1	8	8*	4	20	120

4.1.2 Uplink

4.1.2.1 Example for RACH

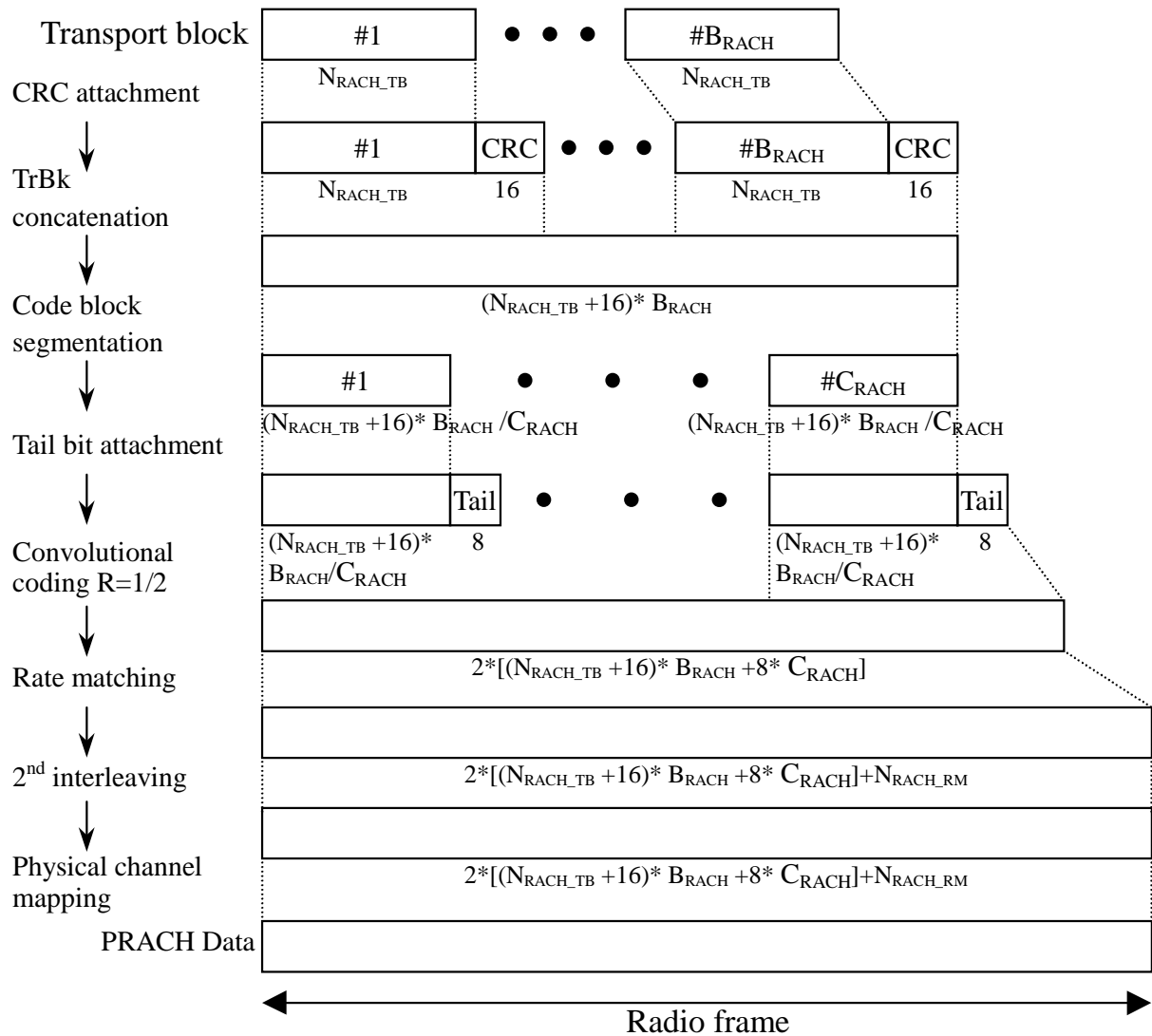

Figure 11: Channel coding and multiplexing example for PRACH

4.1.2.2 Example for DCH

4.1.2.2.1 DCH -> Radio frame segmentation

4.1.2.2.1.1 Example for 4.1 kbps data

NOTE: This example can be applied to DCCH.

Table 11: Parameter examples for 4.1 kbps data

Transport block size	164 bits
Transport block set size	164 bits
CRC	16 bits
Coding	CC, coding rate = 1/3
TTI	40 ms

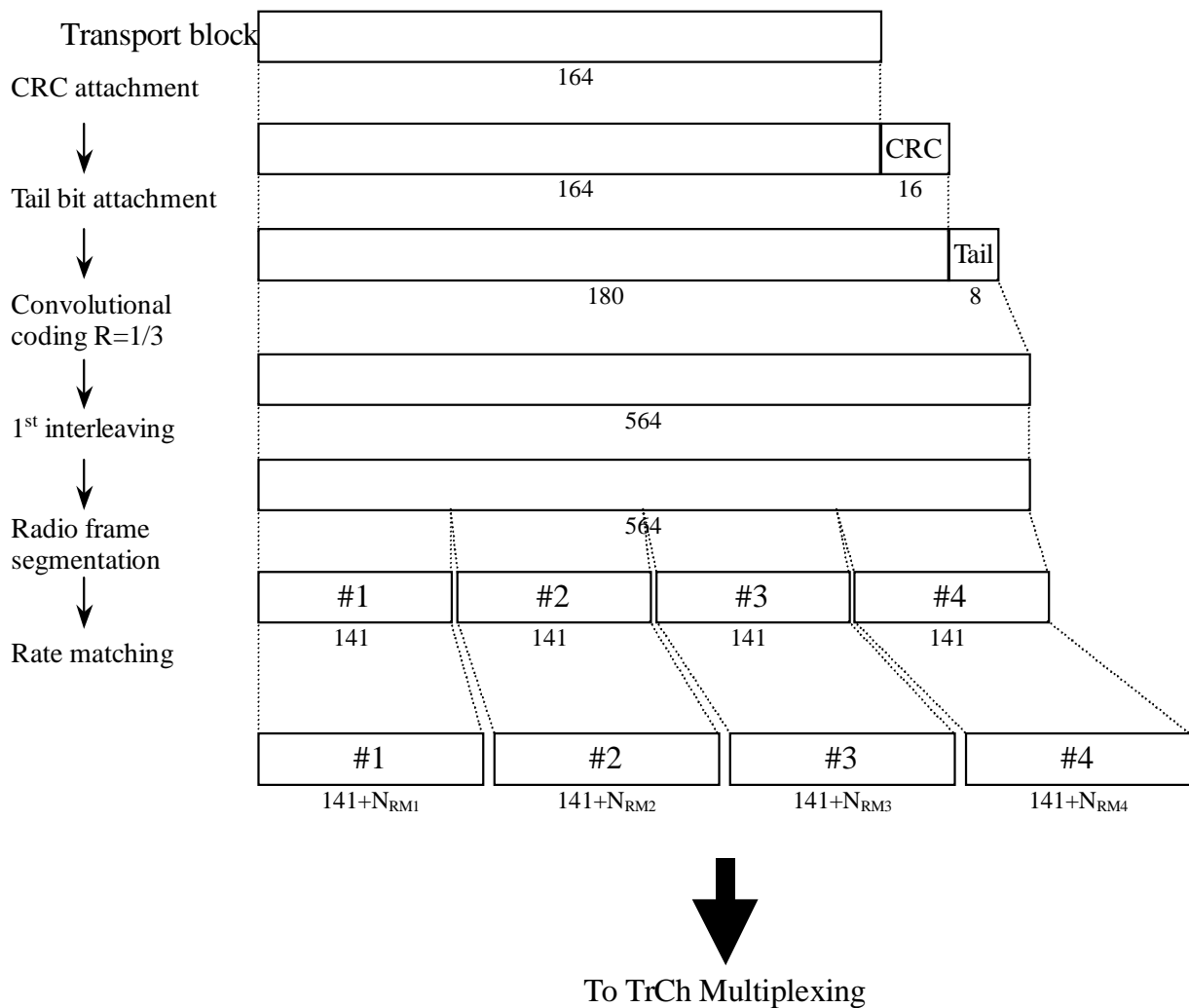

Figure 12: Channel coding and multiplexing example for 4.1 kbps data

4.1.2.2.1.2 Example for 12.2 kbps data

NOTE: This example can be applied to AMR speech.

Table 12: Parameter examples for 12.2 kbps data

The number of TrChs	3
Transport block size	81, 103, 60, and bits
CRC	12 bits (attached only to TrCh#1)
Coding	CC, coding rate = 1/3 for TrCh#1, 2 coding rate = 1/2 for TrCh#3
TTI	20 ms

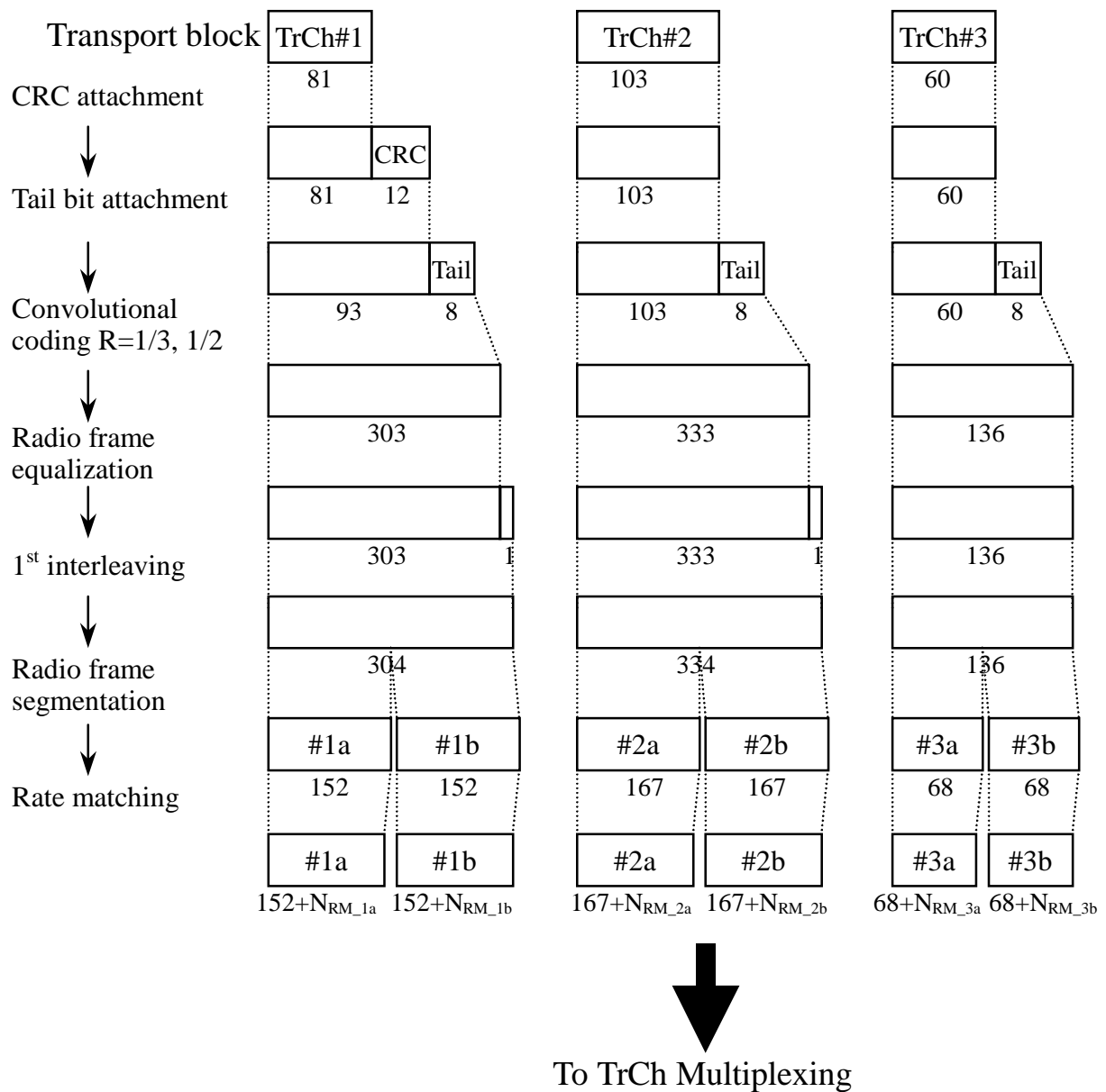

Figure 13: Channel coding and multiplexing example for 12.2 kbps data

4.1.2.2.1.3 Example for 64/128/384 kbps packet data

Table 13: Parameters for 64/128/384 kbps packet data

The number of TrChs		1
Transport block size		640 bits
Transport block	64 kbps	$640 \cdot B$ bits ($B = 0, 1$)
Size size	128 kbps	$640 \cdot B$ bits ($B = 0, 1, 2$)
	384 kbps	$640 \cdot B$ bits ($B = 0, 1, 2, \dots, 6$)
CRC		16 bits
Coding		Turbo coding, coding rate = 1/3
TTI		10 ms

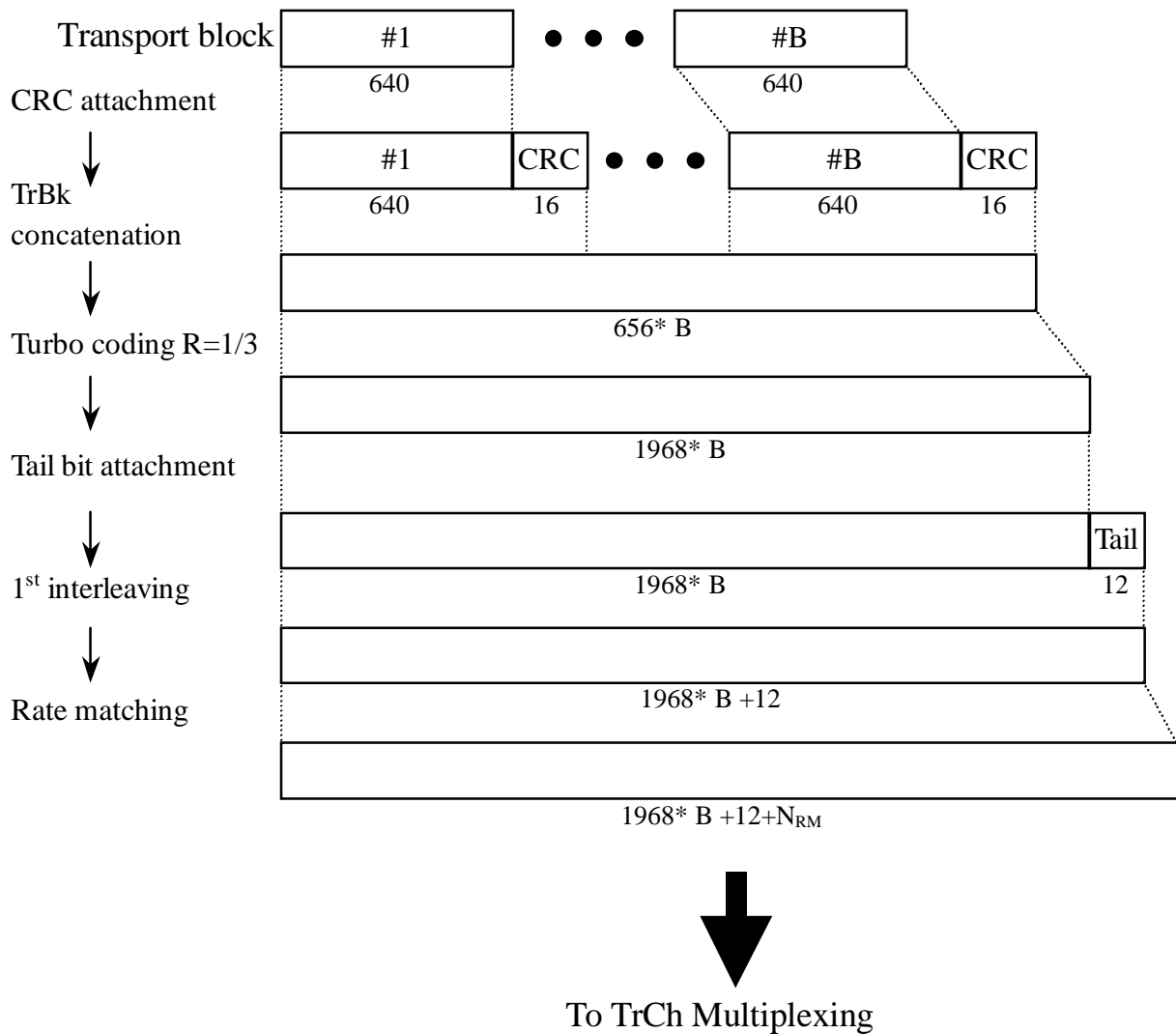

Figure 14: Channel coding and multiplexing example for 64/128/384 kbps packet data

4.1.2.2.1.4 Example for 64 kbps data

NOTE: This example can be applied to ISDN service.

Table 14: Parameters for 64 kbps data

The number of TrChs	1
Transport block size	640 bits
Transport block set size	4*640 bits
CRC	16 bits
Coding	Turbo coding, coding rate = 1/3
TTI	40 ms

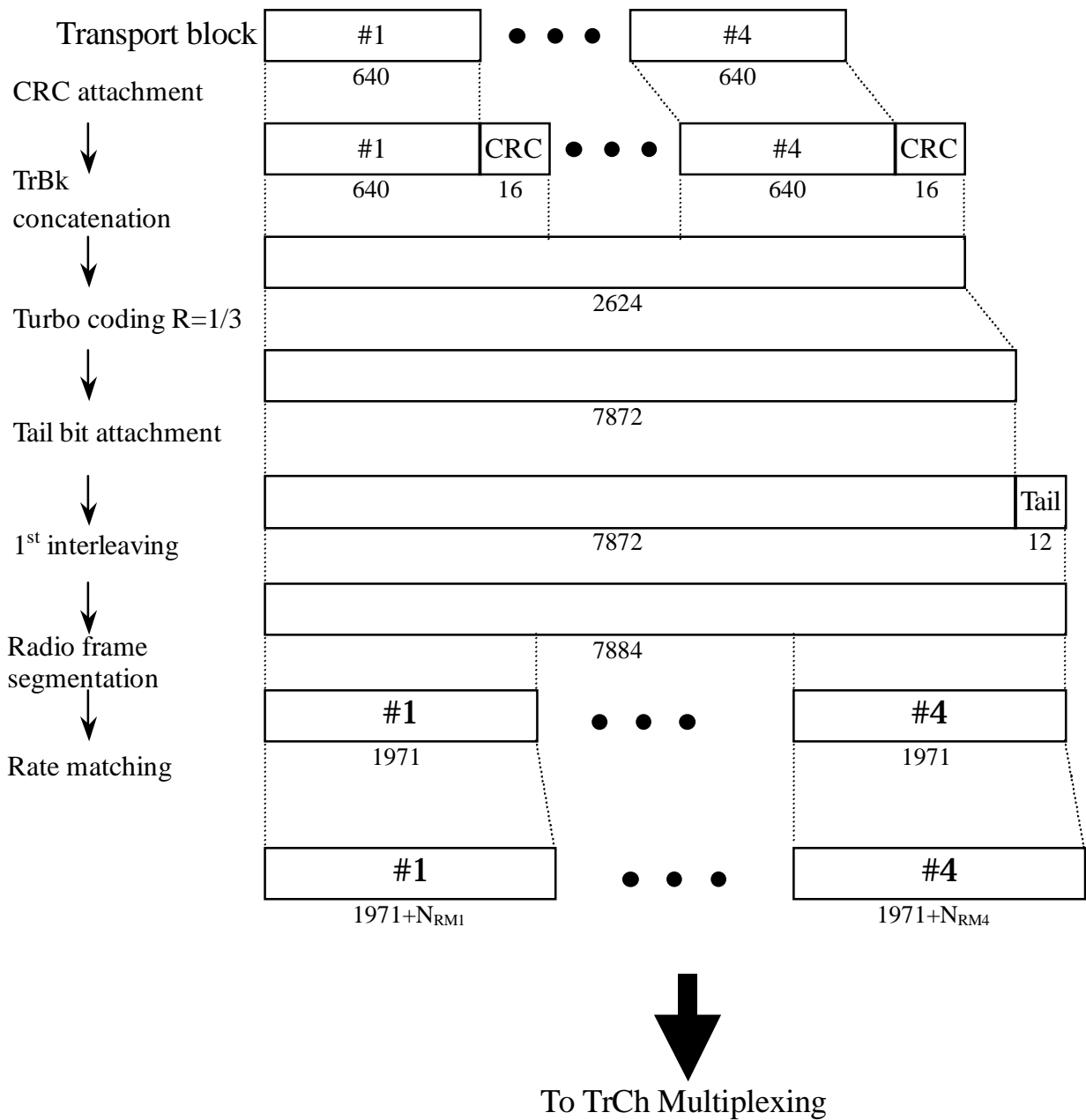

Figure 15: Channel coding and multiplexing example for 64 kbps data

4.1.2.2.2 TrCH multiplexing -> Physical channel mapping

4.1.2.2.2.1 Example for Stand-alone mapping of 4.1 kbps data

NOTE: This example can be applied to Stand-alone mapping of DCCH.

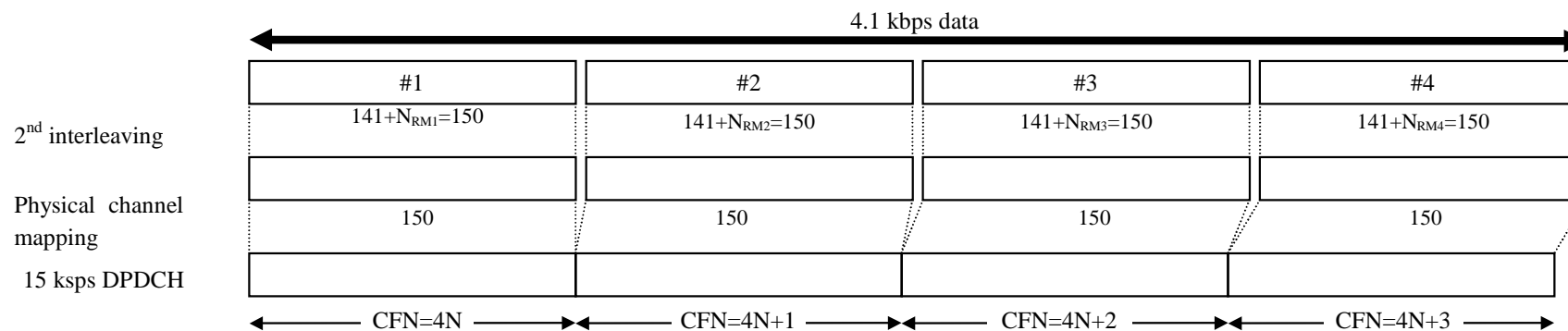

Figure 16: Channel coding and multiplexing example for stand-alone mapping of 4.1 kbps data

4.1.2.2.2 Example for multiplexing of 12.2 kbps data and 4.1 kbps data

NOTE: This example can be applied to multiplexing AMR speech and DCCH.

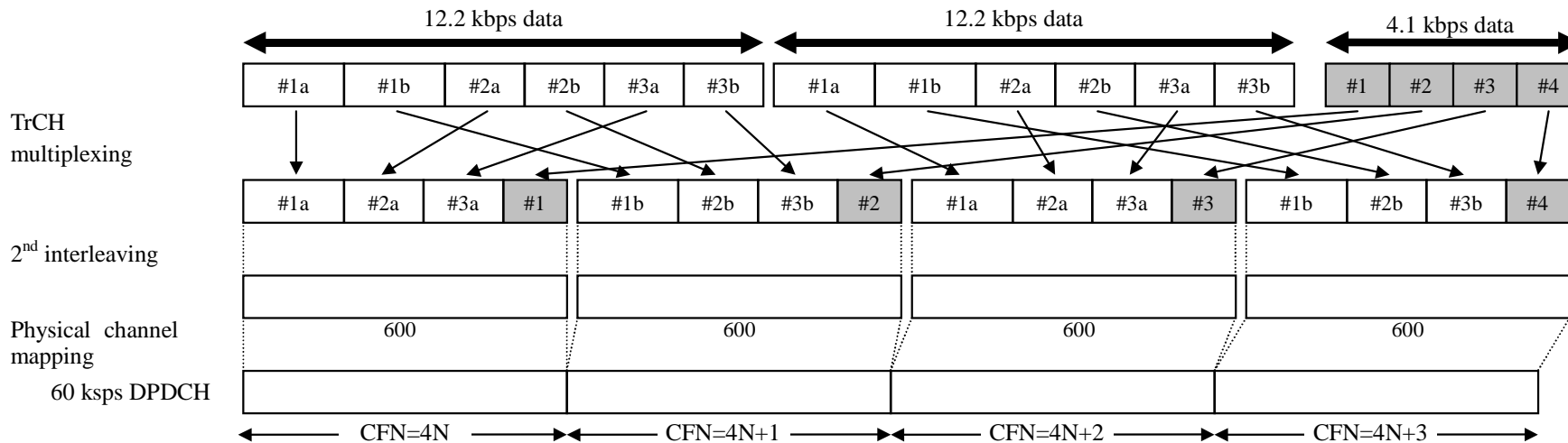

Figure 17: Channel coding and multiplexing example for multiplexing of 12.2 kbps data and 4.1 kbps data

4.1.2.2.2.3 Example for multiplexing of 64/128/384 kbps packet data and 4.1 kbps data

NOTE: This example can be applied to multiplexing 64/128/384 kbps packet data and DCCH.

Table 15 shows example of physical channel parameters for multiplexing of 64/128/384 kbps packet data and 4.1 kbps data.

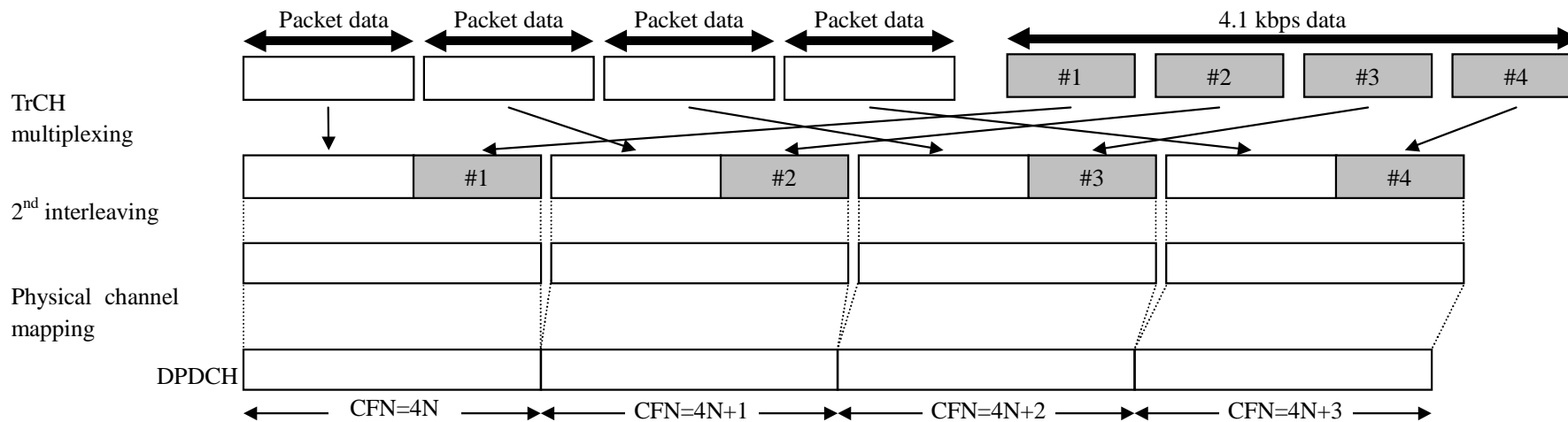

Figure 18: Channel coding and multiplexing example for multiplexing of 64/128/384 kbps packet data and 4.1 kbps data

Table 15: Physical channel parameters for multiplexing of 64/128/384 kbps packet data and 4.1 kbps data

Data rate (kbps)	Symbol rate (ksps)	No. of physical channel
64	240	1
128	480	1
384	960	1

4.1.2.2.2.4 Example for multiplexing of 64 kbps data and 4.1 kbps data

NOTE: This example can be applied to multiplexing ISDNs data and DCCH.

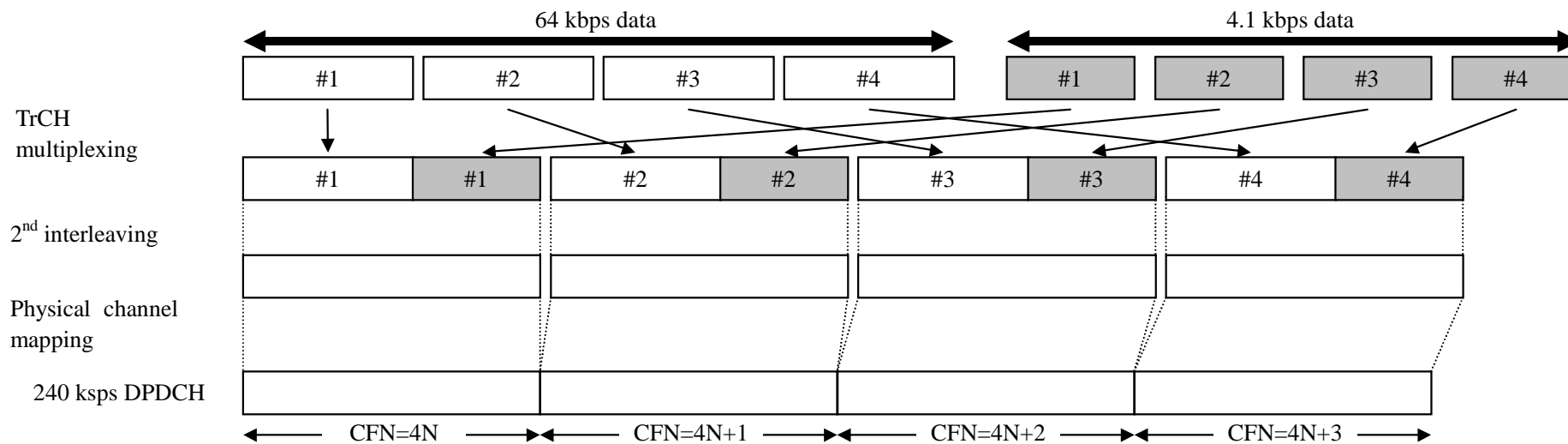

Figure 19: Channel coding and multiplexing example for multiplexing of 64 kbps data and 4.1 kbps data

4.2 TDD mode

4.2.1 Downlink

4.2.1.1 BCH

Table 16: Parameters for BCH

Transport block size	246 bits
CRC	16 bits
Coding	CC, coding rate = 1/2
TTI	20 ms
Midamble	512 chips
Codes and time slots	SF = 16 x 1 x 1 time slot
TFCI	0 bit
TPC	0 bit

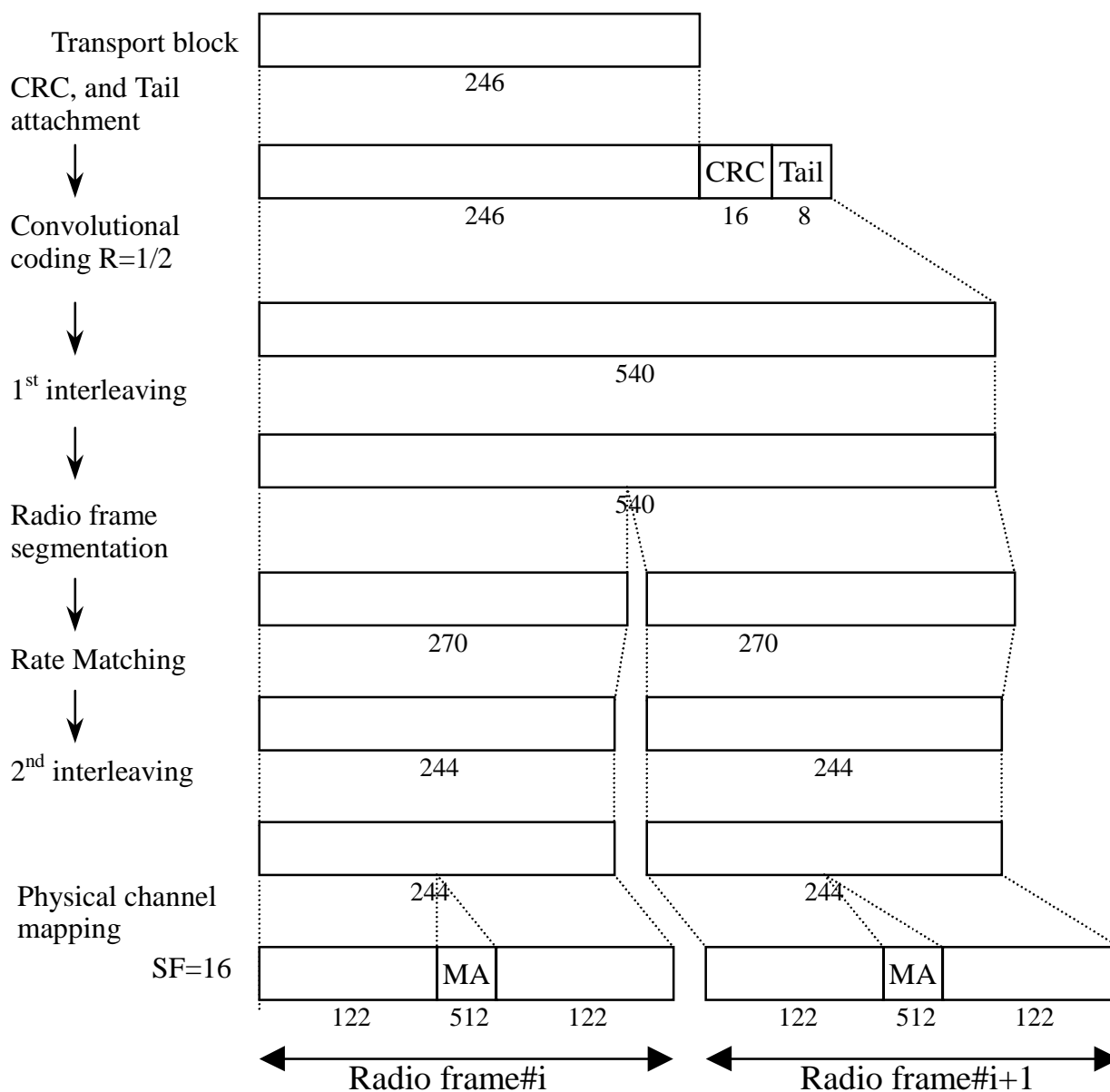

Figure 20: Channel coding for BCH

4.2.1.2 Example for PCH

Table 17: Parameters for PCH

CRC	8 bits
Coding	CC, coding rate = 1/2
TTI	20 ms
Midamble	512 chips
Codes and time slots	SF = 16 x 1 x 1 time slot
TFCI	0 bit
TPC	0 bit

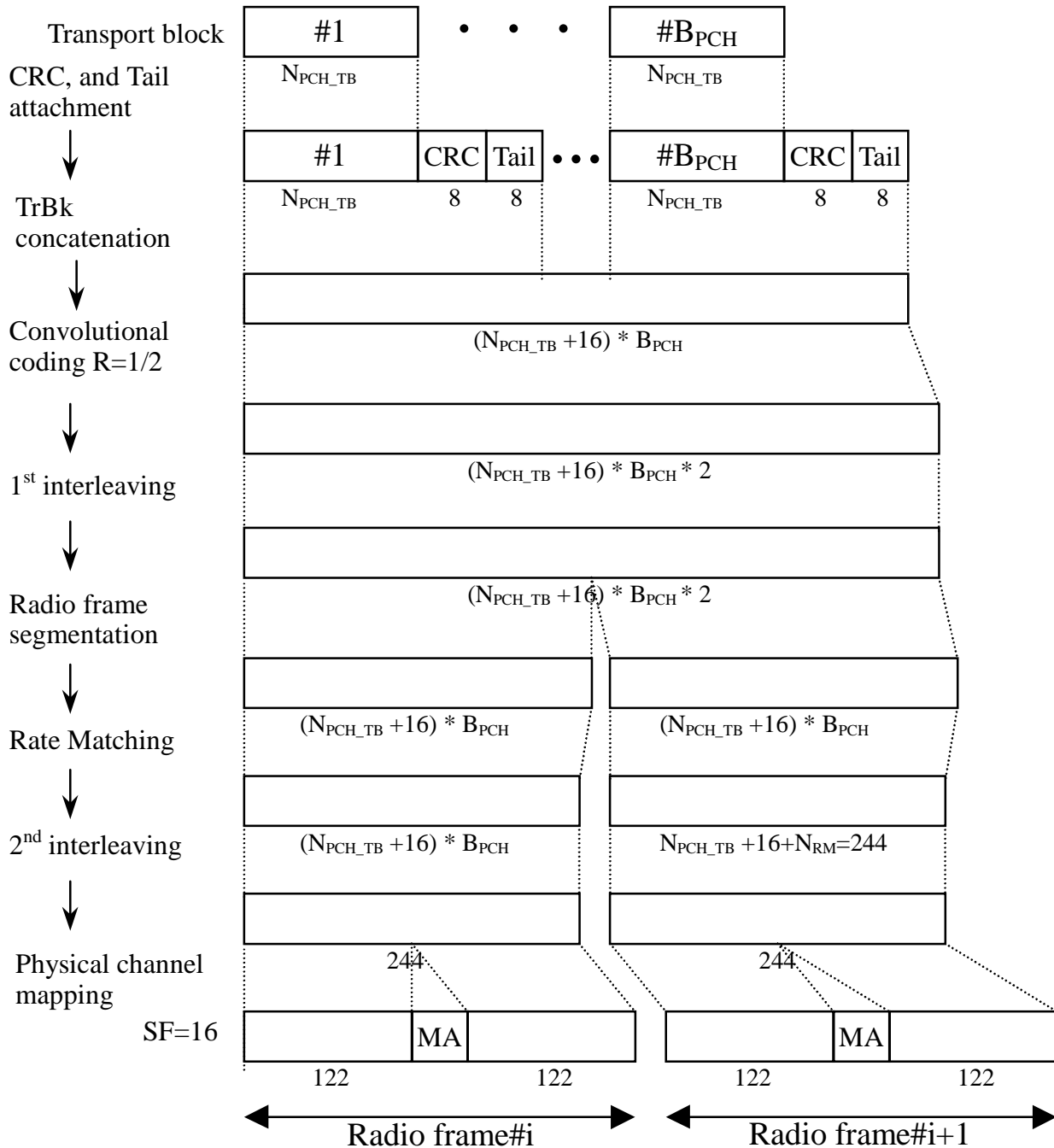

Figure 21: Channel coding and multiplexing example for PCH

4.2.1.3 Example for FACH

Table 18: Parameters for FACH

CRC	8 bits
Coding	CC, coding rate = 1/2
TTI	20 ms
Midamble	512 chips
Codes and time slots	SF = 16 x 1 x 1 time slot
TFCI	0 bit
TPC	0 bit

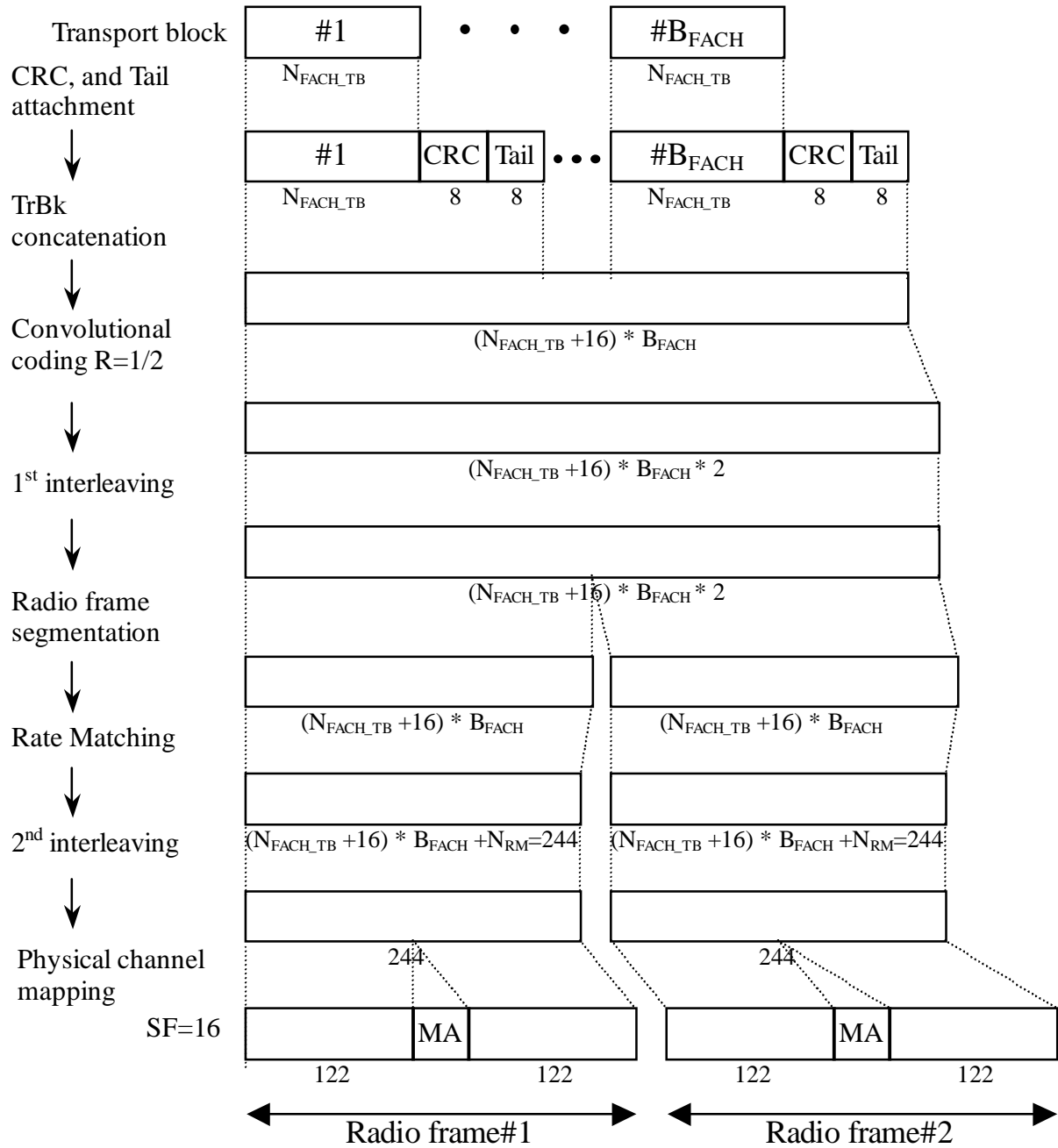

Figure 22: Channel coding and multiplexing example for FACH

4.2.1.4 Example for DCH

4.2.1.4.1 DCH-> Radio frame segmentation

4.2.1.4.1.1 Example for 2.4 kbps data

NOTE: This example can be applied to DCCH.

Table 19: Parameter examples for 2.4 kbps data

Transport block size	96 bits
Transport block set size	96 bits
CRC	16 bits
Coding	CC, coding rate = 1/3
TTI	40 ms

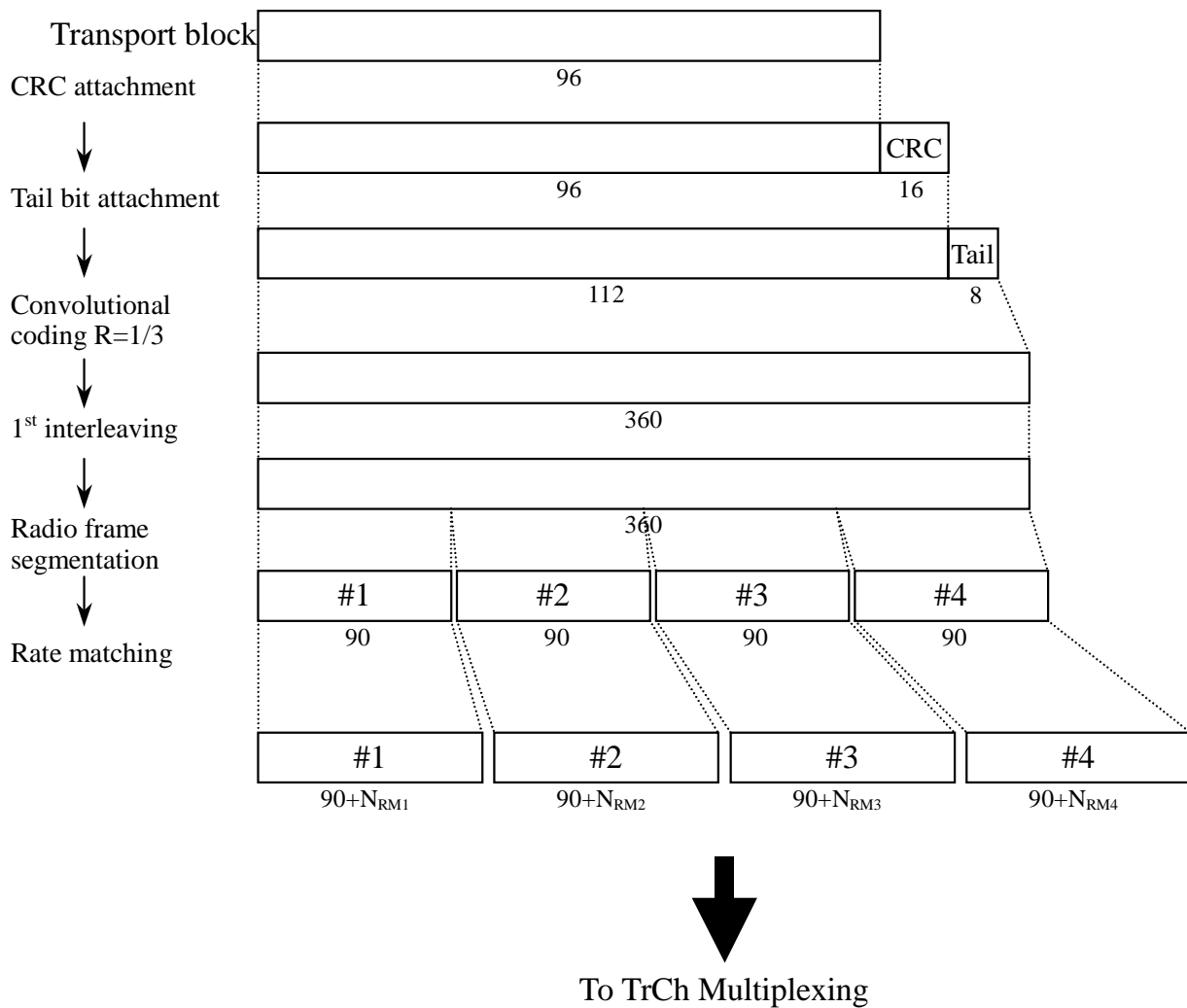

Figure 23: Channel coding and multiplexing example for 2.4 kbps data

4.2.1.4.1.2 Example for 12.2 kbps data

NOTE: This example can be applied to AMR speech.

Table 20: Parameter examples for 12.2 kbps data

The number of TrChs	3
Transport block size	81, 103, and 60 bits
CRC	12 bits (attached only to TrCh#1)
Coding	CC, coding rate = 1/3 for TrCh#1, 2 coding rate = 1/2 for TrCh#3
TTI	20 ms

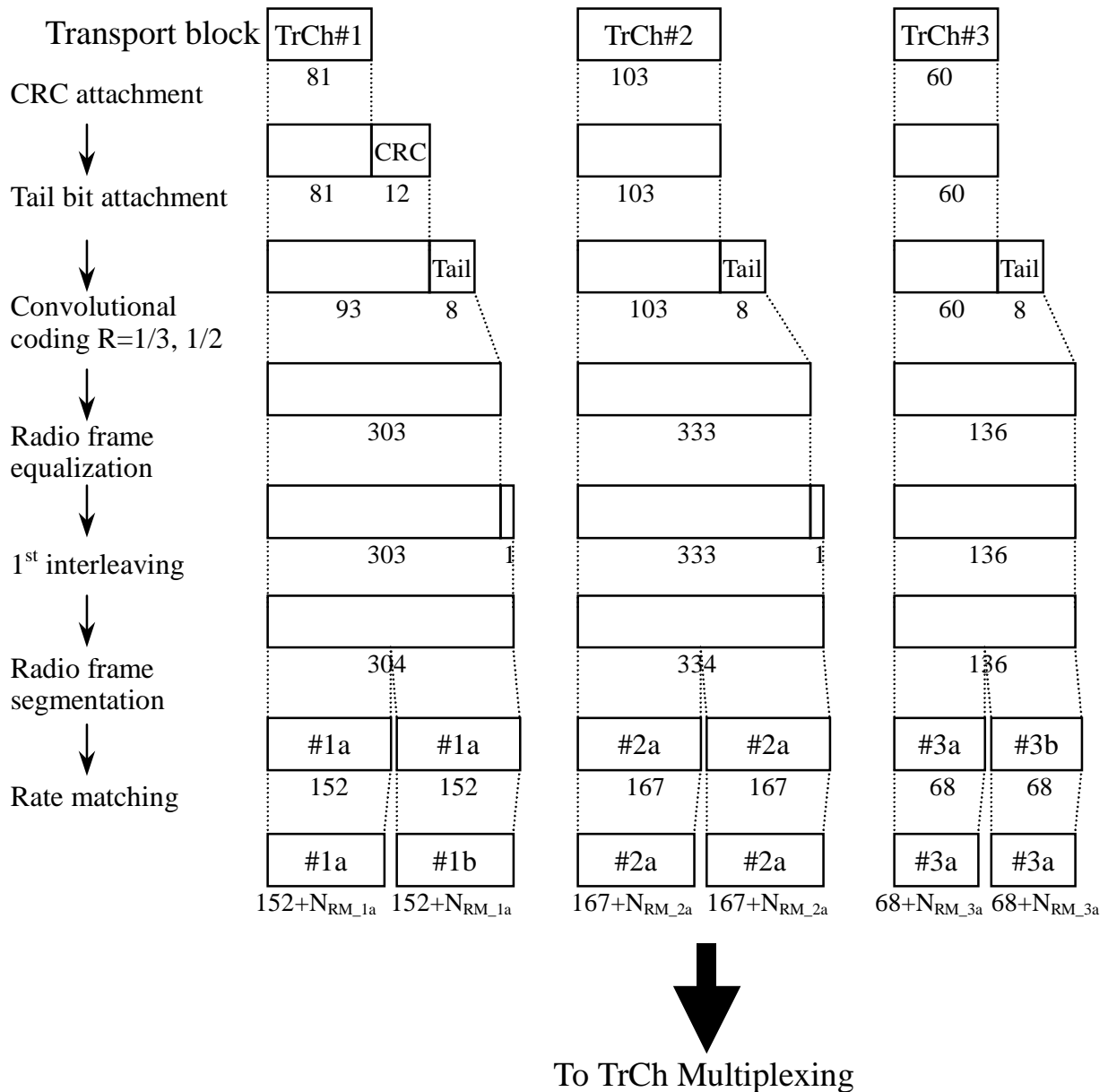

Figure 24: Channel coding and multiplexing example for 12.2 kbps data

4.2.1.4.1.3

Example of 64/128/384 kbps packet data

Table 21: Parameters for 64/128/384 kbps packet data

The number of TrChs		1
Transport block	64 kbps	1280 bits
Size: S	128 kbps	2560 bits
	384 kbps	3840 bits
Transport block	64 kbps	1280*B bits (B = 0, 1)
set size	128 kbps	2560*B bits (B = 0, 1)
	384 kbps	3840*B bits (B = 0, 1, 2)
Code block	64 kbps	1
segmentation: C	128 kbps	1
	384 kbps	1 (B = 0, 1) or 2 (B = 2)
CRC		16 bits
Coding		Turbo coding, coding rate = 1/3
TTI		20 ms

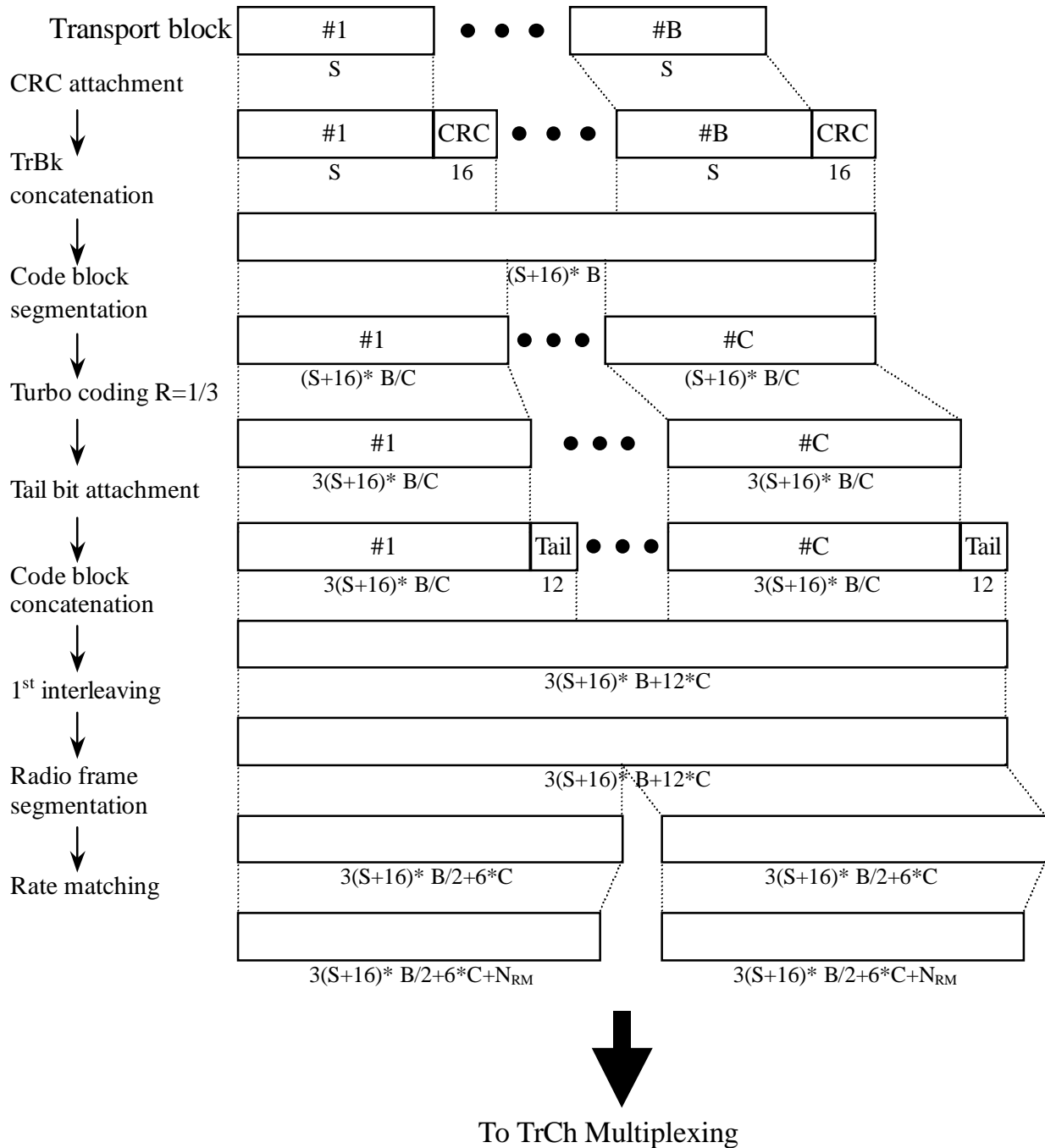

Figure 25: Channel coding and multiplexing example for 64/128/384 kbps packet data

4.2.1.4.1.4 Example for 64 kbps data

NOTE: This example can be applied to ISDN service.

Table 22: Parameters for 64 kbps data

The number of TrChs	1
Transport block size	1280 bits
Transport block set size	1280 bits
CRC	16 bits
Coding	Turbo coding, coding rate = 1/3
TTI	20 ms

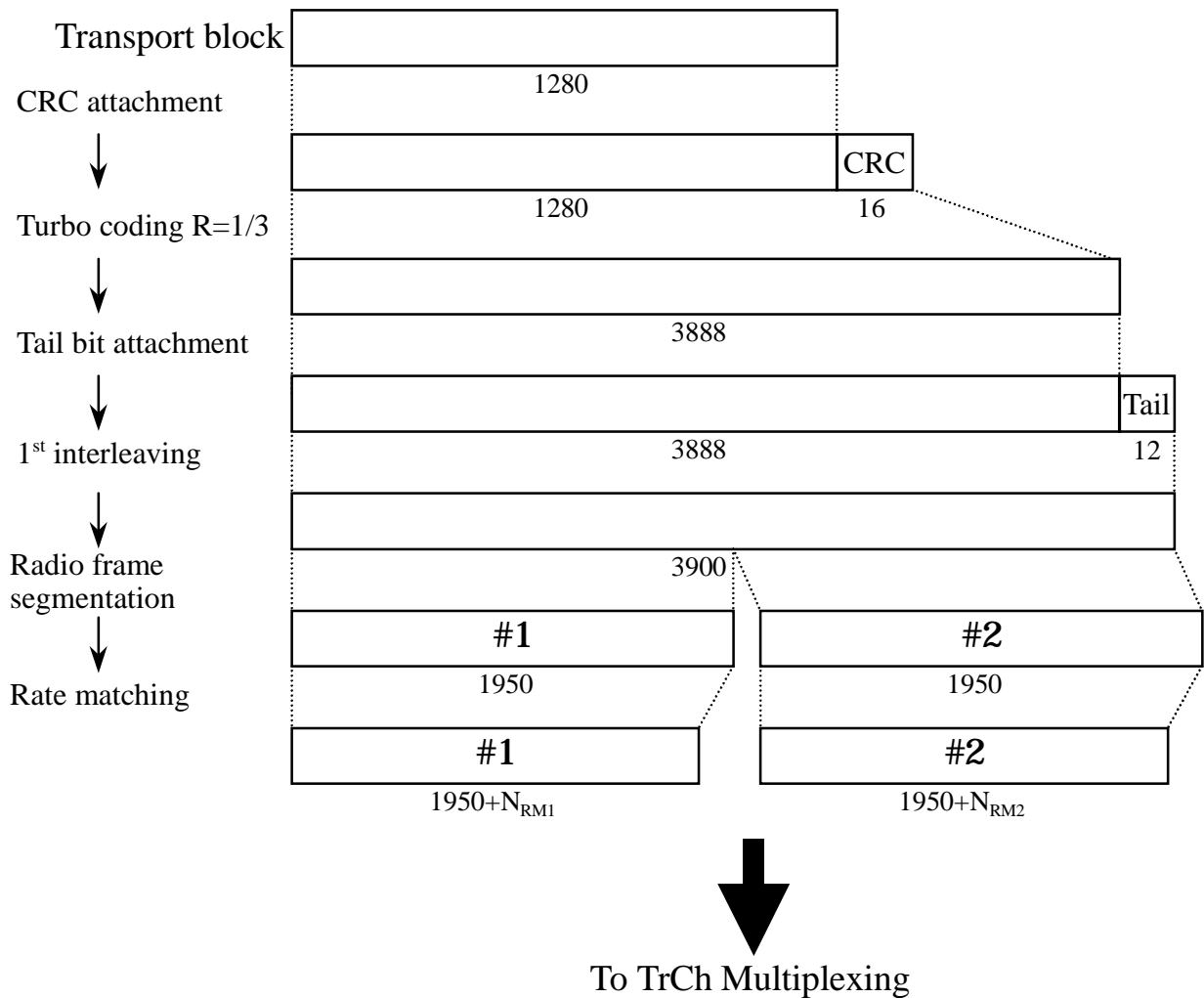

Figure 26: Channel coding and multiplexing example for 64 kbps data

4.2.1.4.2 TrCH multiplexing -> Physical channel mapping

4.2.1.4.2.1 Example for Stand-alone mapping of 2.4 kbps data

NOTE: This example can be applied to Stand-alone mapping of DCCH.

Table 23 shows example of physical channel parameters for Stand-alone mapping of 2.4 kbps data.

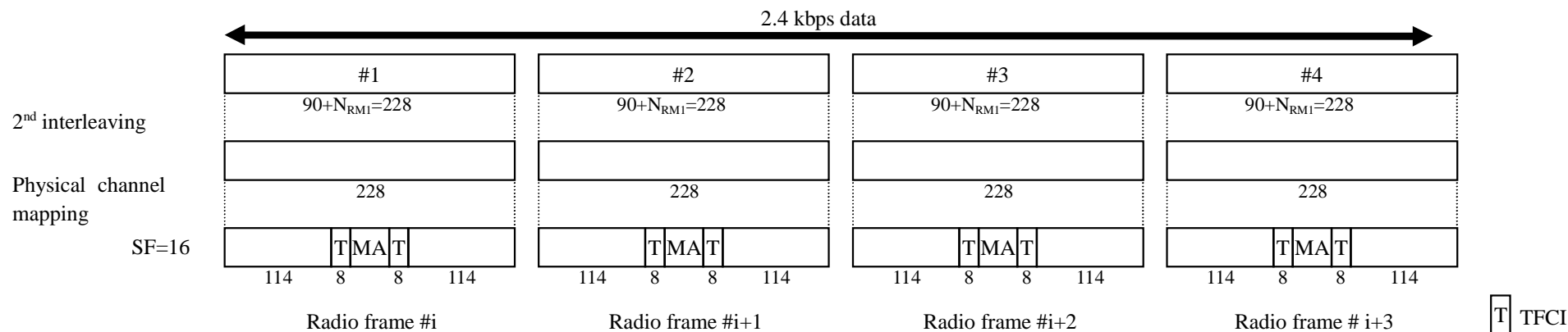

Figure 27: Channel coding and multiplexing example for Stand-alone mapping of 2.4 kbps data

Table 23: Physical channel parameters for Stand-alone mapping of 2.4 kbps data

Midamble	512 chips
Codes and time slots	SF16 x 1 code x 1 time slot
TFCI	16 bits per user
TPC	0 bit

4.2.1.4.2.2 Example for multiplexing of 12.2 kbps data and 2.4 kbps data

NOTE: This example can be applied to multiplexing AMR speech and DCCH.

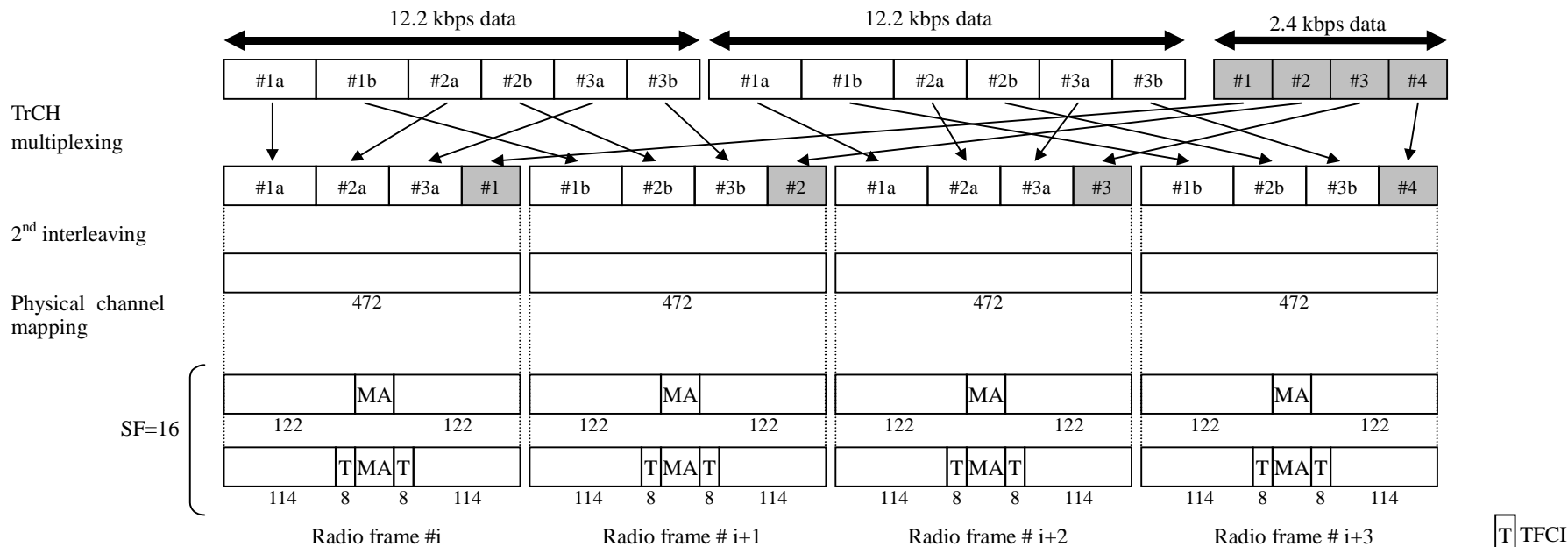

Figure 28: Channel coding and multiplexing example for multiplexing of 12.2 kbps data and 2.4 kbps data

Table 24: Physical channel parameters for multiplexing of 12.2 kbps data and 2.4 kbps data

Midamble	512 chips
Codes and time slots	SF16 x 2 code x 1 time slot
TFCI	16 bits per user
TPC	0 bit

4.2.1.4.2.3 Example for multiplexing of 64/128/384 kbps packet data and 2.4 kbps data

NOTE: This example can be applied to multiplexing 64/128/384 kbps packet data and DCCH.

Table 25 shows example of physical channel parameters for multiplexing of 64/128/384 kbps packet data and 2.4 kbps data.

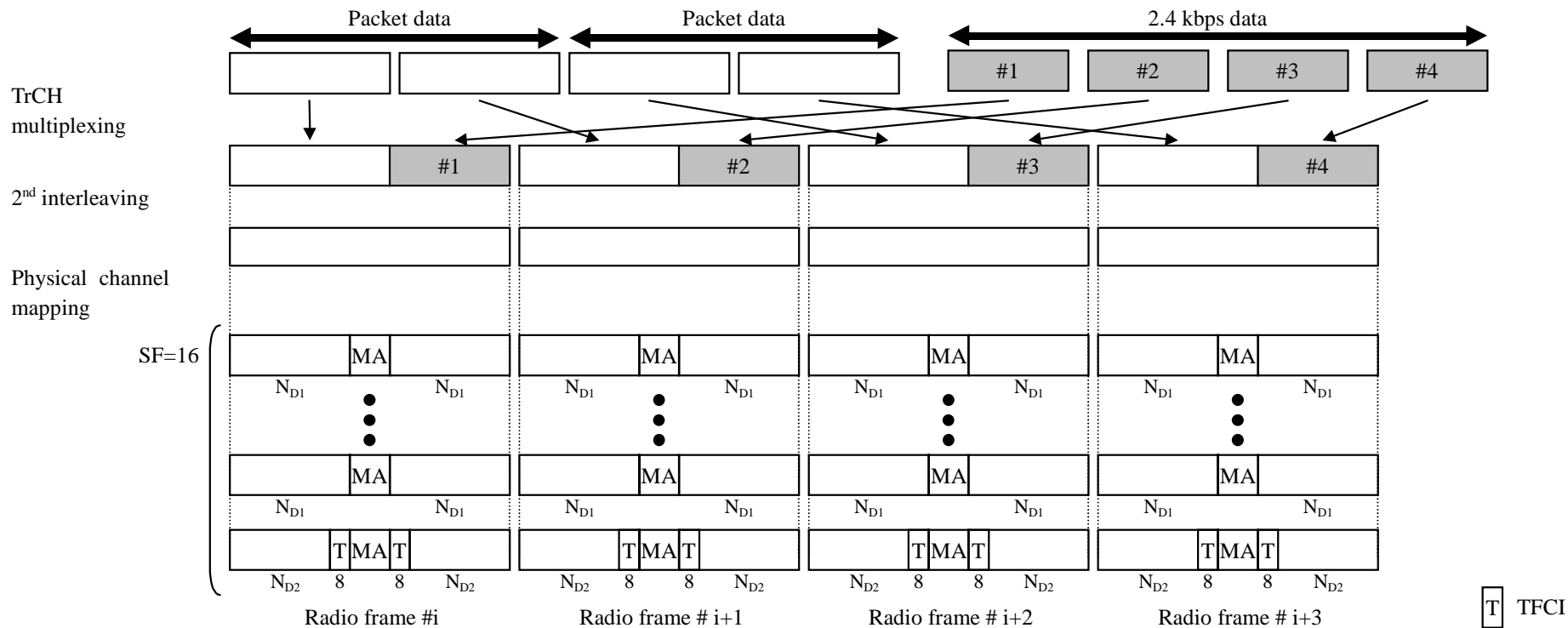

Figure 29: Channel coding and multiplexing example for multiplexing of 64/128/384 kbps packet data and 2.4 kbps data

Table 25: Physical channel parameters for multiplexing of 64/128/384 kbps packet data and 2.4 kbps data

Midamble	64 kbps	512 chips
	128 & 384 kbps	256 chips
N _{D1} , N _{D2}	64 kbps	122 bits, 114 bits
	128 & 384 kbps	138 bits, 130 bits
Code & time slots	64 kbps	SF16 x 5 codes x 1 time slot
	128 kbps	SF16 x 9 codes x 1 time slot
	384 kbps	SF16 x 8 codes x 3 time slots
TFCI		16 bits per user
TPC		0 bit

4.2.1.4.2.4 Example for multiplexing of 64 kbps data and 2.4 kbps data

NOTE: This example can be applied to multiplexing ISDNs data and DCCH.

Table 26 shows example of physical channel parameters for multiplexing of 64/128/384 kbps packet data and 2.4 kbps data.

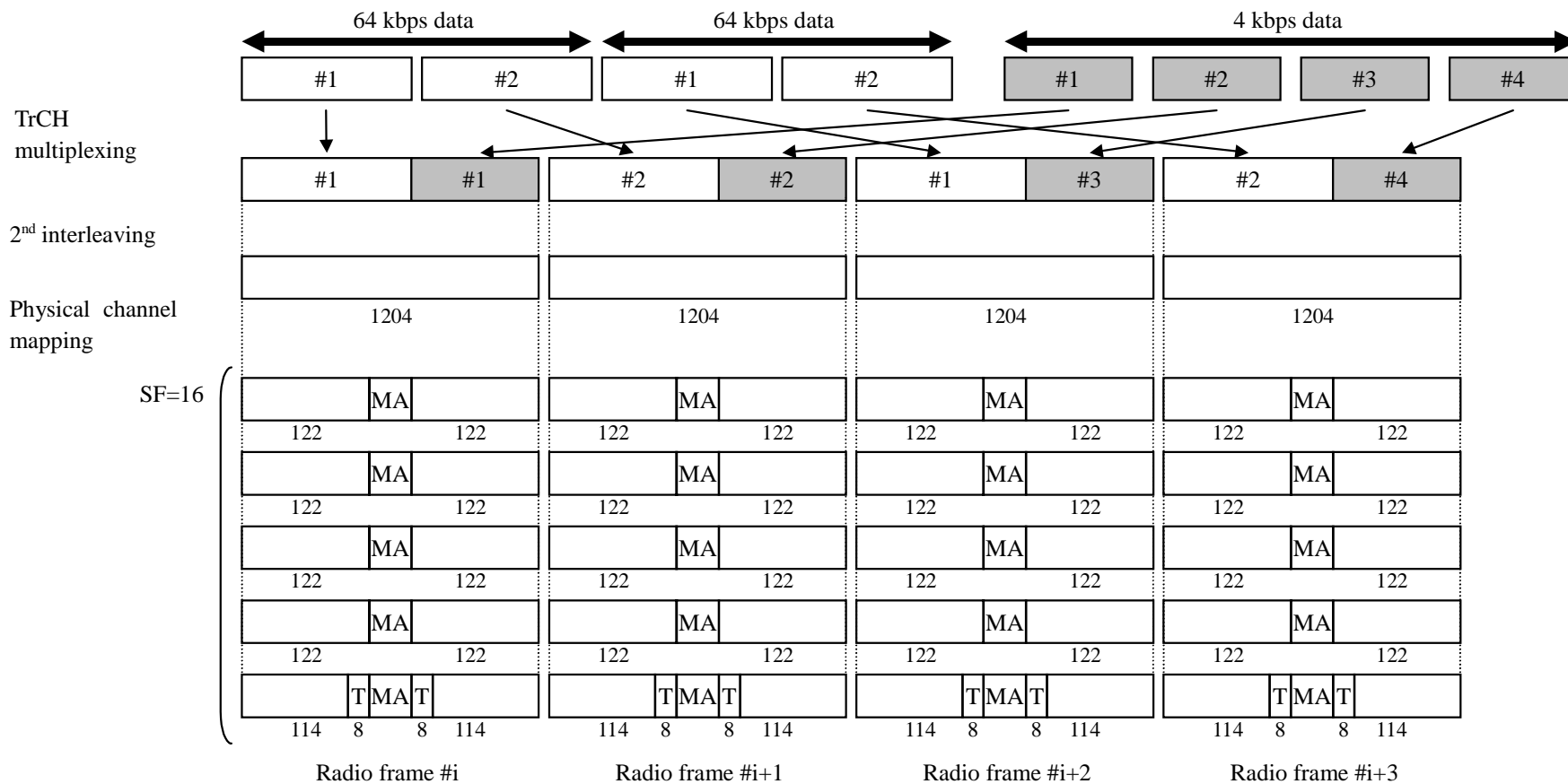

Figure 30: Channel coding and multiplexing example for multiplexing of 64/128/384 kbps packet data and 2.4 kbps data

Table 26: Physical channel parameters for multiplexing of 64/128/384 kbps packet data and 2.4 kbps data

Midamble	512 chips
Code & time slots	SF16 x 5 codes x 1 time slot
TFCI	16 bits per user
TPC	0 bit

4.2.2 Uplink

4.2.2.1 RACH

Table 27: Parameters for RACH

CRC	8 bits
Coding	CC, coding rate = 1/2
TTI	10 ms
Midamble	512 chips
Codes and time slots	SF = 16 x 1 x 1 time slot
TFCI	0 bit
TPC	0 bit

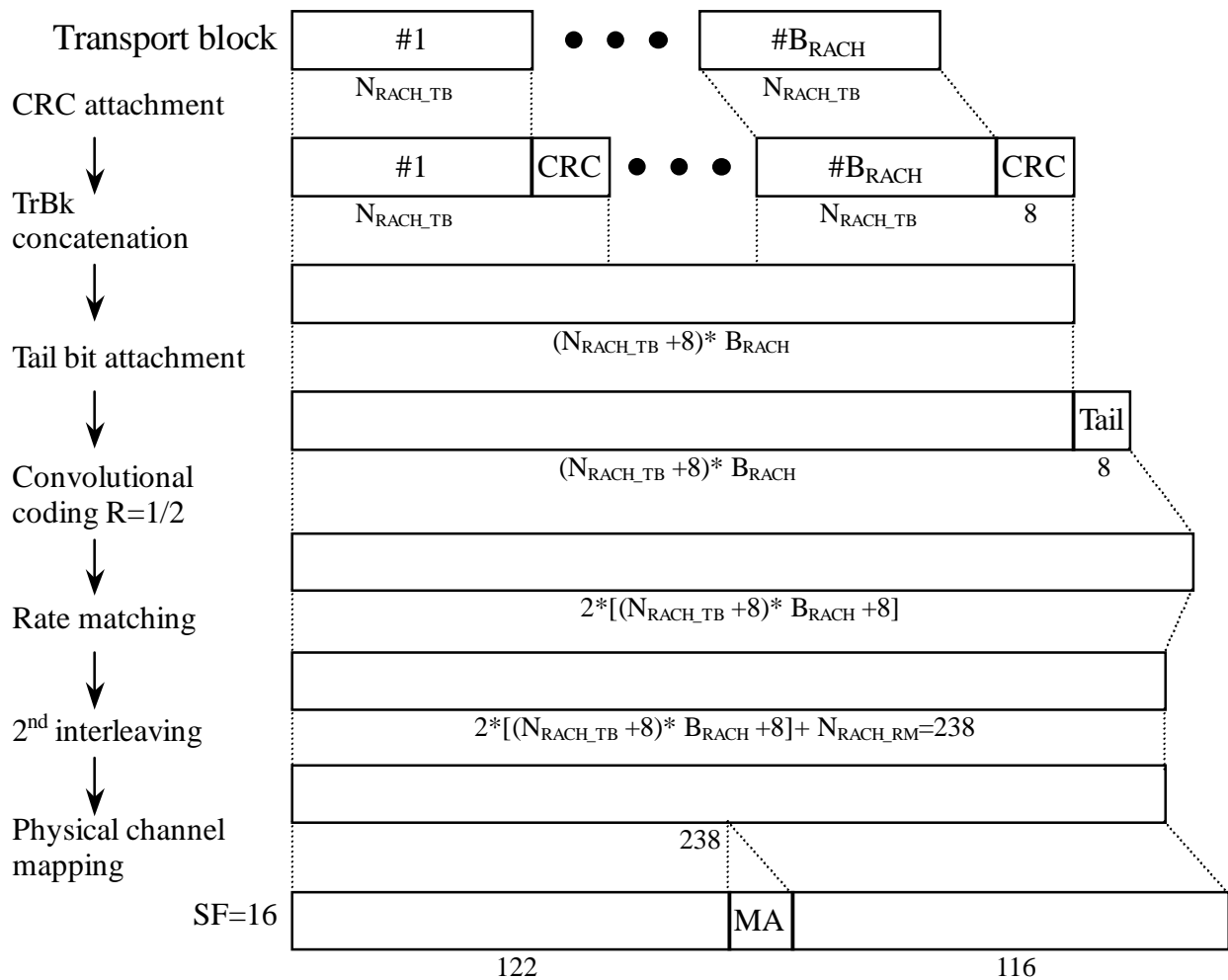

Figure 31: Channel coding and multiplexing example for RACH

4.2.2.2 Example for DCH

4.2.2.2.1 DCH-> Radio frame segmentation

See 4.2.1.4.2.

4.2.2.2.2 TrCH multiplexing -> Physical channel mapping

4.2.2.2.2.1 Example for Stand-alone mapping of 2.4 kbps data

NOTE: This example can be applied to Stand-alone mapping of DCCH.

Table 28 shows example of physical channel parameters for Stand-alone mapping of 2.4 kbps data.

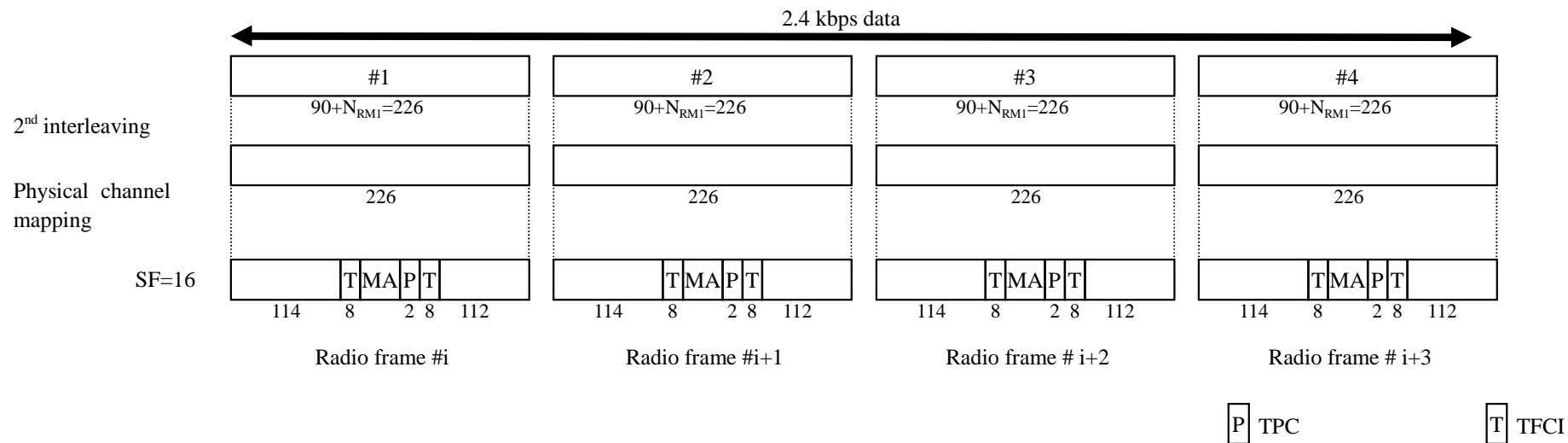

Figure 32: Channel coding and multiplexing example for Stand-alone mapping of 2.4 kbps data

Table 28: Physical channel parameters for Stand-alone mapping of 2.4 kbps data

Midamble	512 chips
Codes and time slots	SF16 x 1 code x 1 time slot
TFCI	16 bits per user
TPC	2 bit

4.2.2.2.2.2 Example for multiplexing of 12.2 kbps data and 2.4 kbps data

NOTE: This example can be applied to multiplexing AMR speech and DCCH.

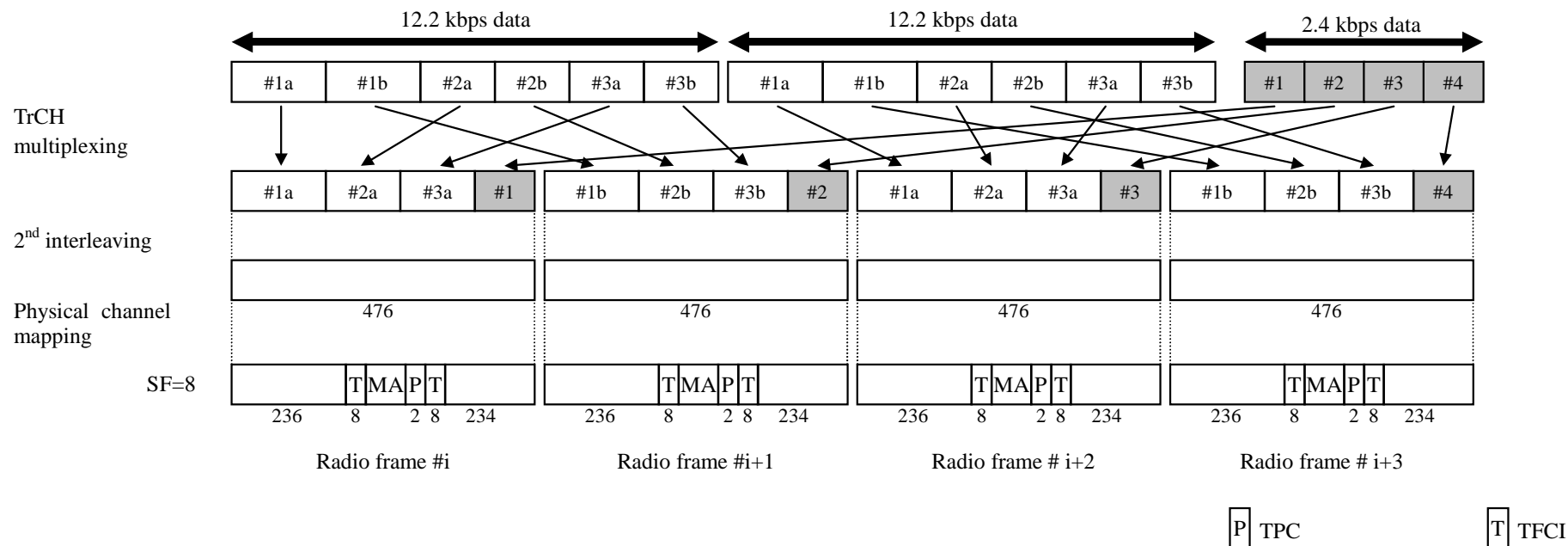

Figure 33: Channel coding and multiplexing example for multiplexing of 12.2 kbps data and 2.4 kbps data

Table 29: Physical channel parameters for multiplexing of 12.2 kbps data and 2.4 kbps data

Midamble	512 chips
Codes and time slots	SF8 x 1 code x 1 time slot
TFCI	16 bits per user
TPC	2 bit

4.2.2.2.2.3 Example for multiplexing of 64/128/384 kbps packet data and 2.4 kbps data

NOTE: This example can be applied to multiplexing 64/128/384 kbps packet data and DCCH.

Table 30 shows example of physical channel parameters for multiplexing of 64/128/384 kbps packet data and 2.4 kbps data.

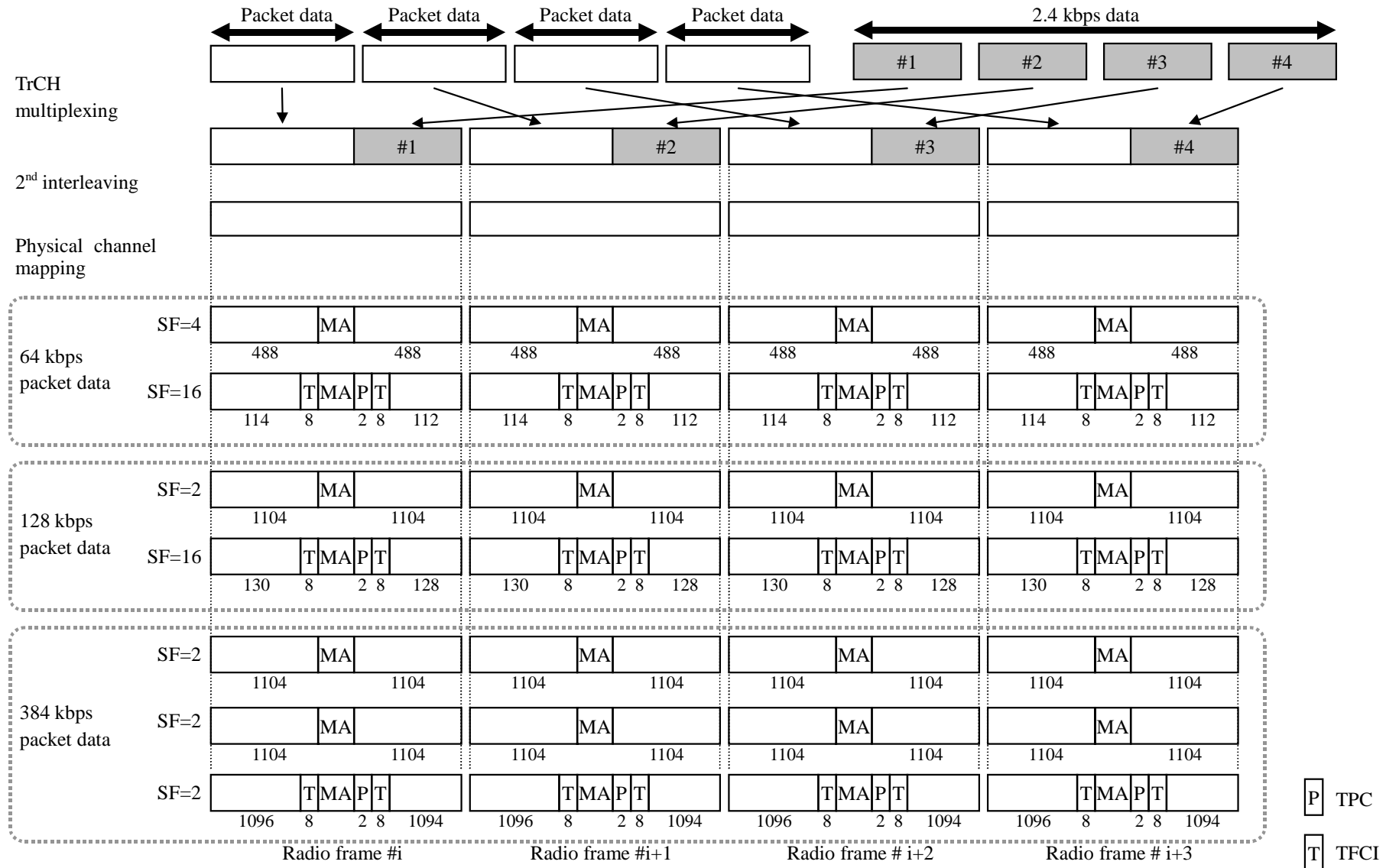

Figure 34: Channel coding and multiplexing example for multiplexing of 64/128/384 kbps packet data and 2.4 kbps data**Table 30: Physical channel parameters for multiplexing of 64/128/384 kbps packet data and 2.4 kbps data**

Midamble	64 kbps	512 chips
	128 & 384 kbps	256 chips
Codes & time	64 kbps	{{(SF16 x 1 code) + (SF4 x 1 code)} x 1 time slot
slots	128 kbps	{{(SF16 x 1 code) + (SF2 x 1 code)} x 1 time slot
	384 kbps	SF2 x 1 code x 3 time slot
TFCI		16 bits per user
TPC		2 bit

NOTE: As an additional example, physical channels can also be mapped without using multicode per timeslot, e.g.:

for 64kbps: (SF16 x 1 code x 1 timeslot) + (SF4x 1 code x 1 timeslot)

for 64kbps: (SF2 x 1 code x 1 timeslot)

for 128kbps: (SF16 x 1 code x 1 timeslot) + (SF2x 1 code x 1 timeslot)

for 128kbps: (SF1 x 1 code x 1 timeslot)

4.2.2.2.2.4 Example for multiplexing of 64 kbps data and 2.4 kbps data

NOTE: This example can be applied to multiplexing ISDNs data and DCCH.

Table 31 shows example of physical channel parameters for multiplexing of 64/128/384 kbps packet data and 2.4 kbps data.

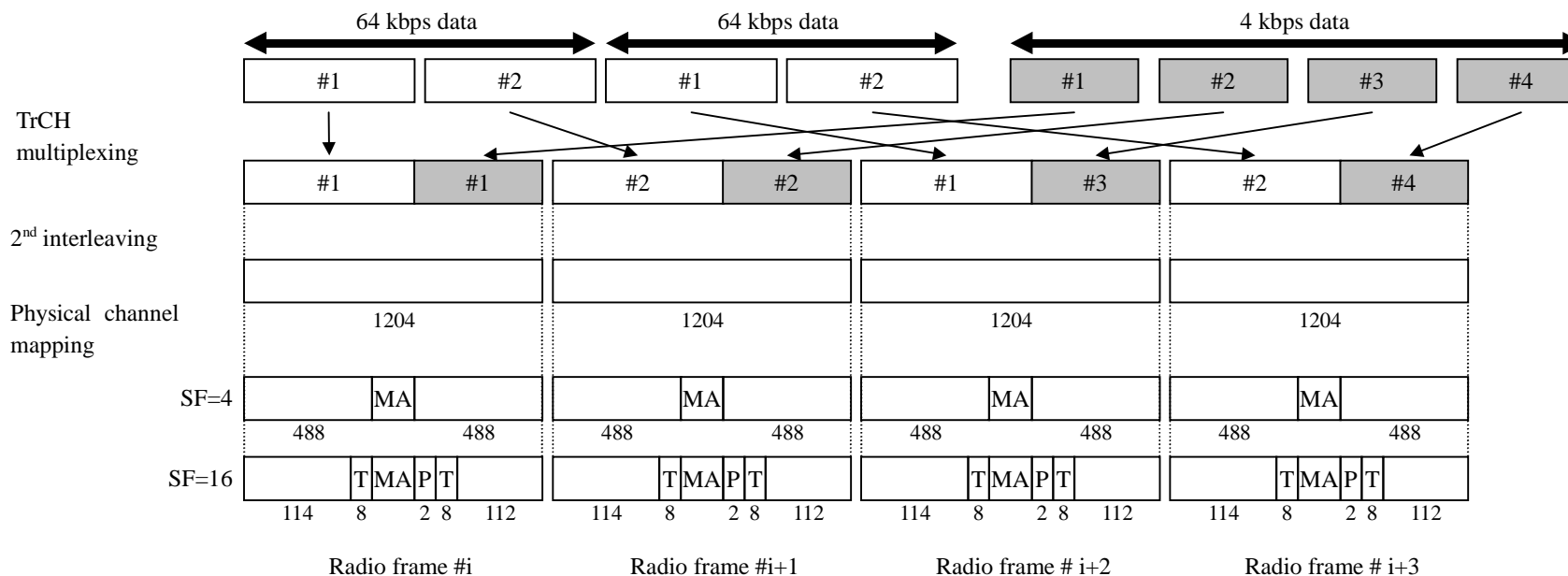

Figure 35: Channel coding and multiplexing example for multiplexing of 64 kbps packet data and 2.4 kbps data

Table 31: Physical channel parameters for multiplexing of 64 kbps packet data and 2.4 kbps data

Midamble	512 chips
Codes & time slots	{(SF16 x 1 code) + (SF4 x 1 code)} x 1 time slot
TFCI	16 bits per user
TPC	2 bit

NOTE: As an additional example, physical channels can also be mapped without using multicode per timeslot, e.g.

for 64kbps: (SF16 x 1 code x 1 timeslot) + (SF4 x 1 code x 1 timeslot)

for 64kbps: (SF2 x 1 code x 1 timeslot)

Annex A (informative): Change history

Change history							
Date	TSG #	TSG Doc.	CR	Rev	Subject/Comment	Old	New
13/03/00	RAN_07	RP-000093	-	-	Approved at TSG RAN #7 and placed under Change Control	-	3.0.0

History

Document history		
V3.0.0	March 2000	Publication